

AD-A132 394

A STUDY OF THE EFFECTIVENESS OF THE ARMY'S NATIONAL  
ADVERTISING EXPENDITURES VOLUME 1 EXECUTIVE SUMMARY (U)  
N W AYER INC NEW YORK 31 AUG 81 81-1 MDA903-79-D-0001

1/1

UNCLASSIFIED

F/G 5/3

NL



END  
DATE  
FILMED  
DTIC

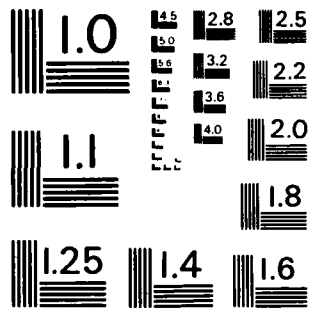

MICROCOPY RESOLUTION TEST CHART  
NATIONAL BUREAU OF STANDARDS - 1963 - A

2

ADA 132394



# UNITED STATES ARMY RECRUITING COMMAND

Study Report 81-1 AD

## A Study of the Effectiveness of the Army's National Advertising Expenditures

Volume I  
Executive Summary

**N W AYER INCORPORATED**  
**AUGUST 1981**

Approved for Public Release  
Distribution Unlimited

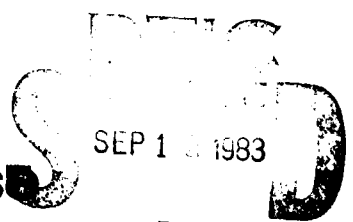

E

DTIC FILE COPY

Prepared for the  
**United States Army Recruiting Command**  
**Fort Sheridan, Illinois 60037**

88 08 24 048

Unclassified

SECURITY CLASSIFICATION OF THIS PAGE (When Data Entered)

REPORT DOCUMENTATION PAGE		READ INSTRUCTIONS BEFORE COMPLETING FORM
1. REPORT NUMBER	2. GOVT ACCESSION NO	3. RECIPIENT'S CATALOG NUMBER
	AD A132	394
4. TITLE (and Subtitle) A STUDY OF THE EFFECTIVENESS OF THE ARMY'S NATIONAL ADVERTISING EXPENDITURES VOLUME I		5. TYPE OF REPORT & PERIOD COVERED Final Draft 27 Sept 79 - 31 Aug 81
7. AUTHOR(s) N W AYER INCORPORATED		6. PERFORMING ORG. REPORT NUMBER
9. PERFORMING ORGANIZATION NAME AND ADDRESS N W Ayer Inc. 1345 Avenue of the Americas New York, NY 10105		8. CONTRACT OR GRANT NUMBER(s) MDA903-79-D-0001
11. CONTROLLING OFFICE NAME AND ADDRESS United States Army Recruiting Command Ft. Sheridan, IL		10. PROGRAM ELEMENT PROJECT, TASK AREA & WORK UNIT NUMBERS
14. MONITORING AGENCY NAME & ADDRESS (if different from Controlling Office) N/A		12. REPORT DATE 31 Aug 81
		13. NUMBER OF PAGES
		15. SECURITY CLASS. (of this report) UNCLASSIFIED
		16. DECLASSIFICATION/DOWNGRADING SCHEDULE N/A
16. DISTRIBUTION STATEMENT (of this Report) Approved for public release; distribution unlimited.		
17. DISTRIBUTION STATEMENT (of the abstract entered in Block 20, if different from Report) N/A		
18. SUPPLEMENTARY NOTES Volume I of three volumes		
19. KEY WORDS (Continue on reverse side if necessary and identify by block number) ADVERTISING, ACCESSIONS, CONTRACTS, ACCESSIONS AS CONTRACTED, ARMY, RECRUITING, EFFECTIVENESS, COST, MODEL, BOX-JENKINS, ECONOMETRIC, ASVAB, EXAMS, CONVERSION, LINKAGE.		
20. ABSTRACT (Continue on reverse side if necessary and identify by block number) ARMY ADVERTISING COST-EFFECTIVENESS MODEL. → The Army's advertising expenditures were shown to be cost-effective in a two-stage modeling process. Advertising was related to ASVAB exams, and exams were then related to accessions. ↑		

FOREWORD

The U.S. Army Recruiting Command (USAREC) has asked N W Ayer Incorporated to study the effectiveness of the Army's national recruitment advertising. N W Ayer's Marketing Services Department undertook this task in September, 1979, with guidance from USAREC's Program Analysis and Evaluation Division. In addition, their assistance in acquiring, providing, and checking data and data sources was essential.

Volume I is the Executive Summary and is intended for the general reader who wants an overview of the project's objectives, methods, and key findings. This summary highlights the marketing and financial aspects of the analysis.

Volume II is the Main Report and is intended for the reader who wants to fully understand the details of the project: its inception, methodology, data, results, validation, and economic implications.

Volume III is comprised of Appendices intended for the specialist who wants to thoroughly analyze the methods and data used in the analysis. A step by step description of how the model was built is documented in the Appendix entitled "Essential Elements of Analysis."

At our request our methodology and conclusions have been reviewed by Professor Martin K. Starr of the Graduate School of Business of Columbia University. He judged our statistical procedures sound and the conclusions acceptable on a statistical and analytic basis.

The findings in this report are not to be construed as an official Department of the Army position, unless so designated by other authorized documents.

Accession For	
NTIS GRA&I	<input checked="" type="checkbox"/>
DTIC TAB	<input type="checkbox"/>
Unannounced	<input type="checkbox"/>
Justification	
By	
Distribution/	
Availability Codes	
Avail and/or	
Dist	Special
<b>A</b>	

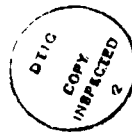

A STUDY OF THE EFFECTIVENESS OF  
THE ARMY'S NATIONAL ADVERTISING EXPENDITURES  
VOL. I  
EXECUTIVE SUMMARY

OBJECTIVES.....	1
RESULTS.....	1
METHOD.....	1
KEY FINDINGS.....	3
Advertising Effects Differ by Target Group.....	3
Effects of an Extra \$1,000,000 of Advertising.....	3
Relative Cost-Effectiveness of Advertising.....	3
Effect of Terminating the GI Bill.....	6
Effect of Change in Total Objectives.....	6
Exams to Accessions Conversion Rate.....	6
Model Reliability and Validation.....	7
CONCLUSIONS.....	7

VOL. II  
MAIN REPORT

CHAPTER 1  
INTRODUCTION

Section I.	PROBLEM.....	1-1
Section II.	HISTORY OF THE APPROACH.....	1-1
Section III.	GENERAL METHODS.....	1-2
	Selection of a Criterion.....	1-2
	Experimentation or Econometrics.....	1-3
Section IV.	OTHER STUDIES OF MILITARY RECRUITMENT ADVERTISING.....	1-4
	The GAO Study.....	1-4
	1. The Attitudes and Image Analysis.....	1-4
	2. The Leads Analysis.....	1-4
	The Morey and McCann Study.....	1-5
Section V.	ASSUMPTIONS.....	1-5
Section VI.	SCOPE AND LIMITATIONS.....	1-6

CHAPTER 2  
METHODOLOGY

Section I.	IDENTIFICATION OF THE BASIC PROCEDURAL STRUCTURE.....	2-1
	The Process Flow.....	2-1
	Choice of a Two-Stage Model Building Procedure.....	2-2
Section II.	IDENTIFICATION OF ASSUMPTIONS AND HYPOTHESES.....	2-5
	The Number of Exam Models.....	2-5
	The Form of and Variables in the Exam Models.....	2-5
	The Number of Accession Models.....	2-6
	The Form of and Variables in the Accession Models.....	2-6
Section III.	INSPECTION OF THE DATA ON EXAM-TAKING.....	2-6
Section IV.	ESTIMATION OF THE IMMEDIATE AND DELAYED EFFECTS OF VARIABLES OTHER THAN ADVERTISING ON EXAM-TAKING....	2-7
Section V.	ESTIMATION OF THE CURRENT AND DELAYED EFFECTS OF ADVERTISING.....	2-8
Section VI.	JOINT ESTIMATION OF THE EFFECTS OF THE ADVERTISING AND NON-ADVERTISING VARIABLES.....	2-8
Section VII.	LINKING EXAMS TO ACCESSIONS.....	2-8

CHAPTER 3

DATA

Section I. MEASURES OF RECRUITING PERFORMANCE.....3-1  
Section II. MEASURES OF ADVERTISING EXPENDITURE ACTIVITY.....3-1  
Section III. USAREC-CONTROLLABLE POLICY VARIABLES.....3-2  
Section IV. NON-CONTROLLABLE ENVIRONMENTAL INFLUENCES.....3-2

CHAPTER 4

RESULTS

Section I. INSPECTION OF THE CATEGORY I-III A EXAM DATA.....4-1  
Seasonality and Auto-Correlation.....4-1  
Adjustment For GI Bill Termination.....4-1  
Section II. ESTIMATION OF THE IMMEDIATE AND DELAYED EFFECTS OF  
VARIABLES OTHER THAN ADVERTISING ON CAT I-III A  
EXAMS.....4-3  
Section III. EFFECTS OF THE CURRENT AND DELAYED EFFECTS OF  
ADVERTISING ON CAT I-III A EXAMS.....4-3  
Section IV. JOINT ESTIMATION OF ADVERTISING AND NON-ADVERTISING  
EFFECTS ON EXAM-TAKING.....4-5  
Final CAT I-III A Exam Model.....4-5  
Final CAT III B-IV Exam Model.....4-5  
Section V. LINKING EXAMS TO ACCESSIONS.....4-7  
Accessions and Exams.....4-7  
Manpower Needs and Conversion Rates.....4-8  
Impact of the Other System Variables on the Level  
of Exams.....4-8  
Final Linkage Models.....4-9

CHAPTER 5

VALIDATION

Section I. GOODNESS OF FIT.....5-1  
Fitting Procedure.....5-1  
Evaluation of Fit.....5-1  
Section II. STRUCTURAL SENSITIVITY OF FITTED EXAM MODELS.....5-2  
Variable Exclusion.....5-2  
Split-Half Analysis.....5-3

CHAPTER 6

ECONOMIC IMPLICATIONS

Section I. PROCEDURES.....6-1  
Section II. RESULTS.....6-1  
Implications of a 10% Increase in Advertising.....6-3  
Implications of Increasing Advertising Expenditures  
by \$1,000,000.....6-3  
Advertising Costs Per Recruit.....6-4  
Relative Cost-Efficiency Of Advertising.....6-4  
Increased Objectives.....6-5  
Effect of GI Bill Termination.....6-6

VOLUME III  
APPENDICES

ESSENTIAL ELEMENTS OF ANALYSIS APPENDIX

Section A.1	How Does The Recruiting Process Work?.....	1
Section A.2	How Is The Market Segmented?.....	5
Section A.3	What Key Factors Are In The Data Base?.....	6
Section A.4	What Factors Are Not In The Data Base?.....	9
Section A.5	What Time Frame Does The Analysis Cover?.....	10
Section A.6	Why And How Was A Two-Stage Procedure Selected?.....	11
Section A.7	What Was The Exam Model-Building Strategy?.....	12
Section A.8	What Were the Key Findings Regarding Category I-III A Exams?..	13
A.8.1	What Seasonality Was Found For Category I-III A Exams?.....	13
A.8.2	Why And How Was Exam Data Adjusted To Remove The Effect Of The GI Bill?.....	15
A.8.3	How Do The Key Variables Other Than Advertising Impact Exam Variation?.....	18
A.8.4	What Is The Pre-Advertising Model?.....	26
A.8.5	What Effects Were Hypothesized For Each Of The Media?.....	30
A.8.6	How Was The Complete Category I-III A Exam Model Specified?...	42
Section A.9	How Did The Category IIIB-IV Analysis Compare To The Category I-III A?.....	44
A.9.1	What Seasonality Was Found For Category IIIB-IV Exams?.....	45
A.9.2	Category IIIB-IV Exam Model Cross Correlations With Non-Advertising Factors.....	46
A.9.3	Category IIIB-IV Exams Pre-Advertising Model Specification...51	
A.9.4	Category IIIB-IV Exam Model Media Analysis - Cross Correlations.....	52
A.9.5	Category IIIB-IV Exam Model Final Model Specification.....	61
Section A.10	How Was The Pay Off (Accessions) Related To Exam Variation?..	62
A.10.1	What Are The Key Issues Regarding The Linkage Between Exams And Accessions?.....	64
A.10.2	What Did We Observe In The Time Series Relating Exams And Accessions?.....	65
A.10.3	What Factors Had A Major Impact On The Conversion Rate?.....	69
A.10.4	How Do Variations In Manpower Needs Impact Conversion Rate Variation?.....	73
A.10.5	Do Other Factors Impact The Conversion Rate?.....	81
A.10.6	How Can The Final Linkage Models Best Be Specified?.....	87
Section A.11	Are The Models Robust?.....	92
A.11.1	How Well Does The Two Stage Model Specification Track The Actual Data?.....	93
A.11.2	Are The Exam Models Consistent Over Different Time Spans?...102	
A.11.3	Are The Estimated Advertising Coefficients Sensitive To The Other Variables Included In The Model?.....	105
Section A.12	Step by Step Procedures For Using The Models.....	110

UNTRANSFORMED DATA SERIES APPENDICES

Data Appendix A. Performance Variables

Accessions by Date of Contract

- A.1 High School Degree/Category I-III A
- A.2 High School Degree/Category IIIB-IV
- A.3 Non Degree/Category I-III A
- A.4 Non-Degree/Category IIIB-IV

ASVAB Exams

- A.5 Category I-III A
- A.6 Category IIIB-IV

Data Appendix B. Media Variables

Advertising Spending

- B.1 Television
- B.2 Radio
- B.3 Newspaper
- B.4 Outdoor
- B.5 Direct Mail
- B.6 Local Advertising
- B.7 Regular Magazines
- B.8 Special Magazines

Media Deflators

- B.9 Spot Television
- B.10 Network Television
- B.11 Spot Radio
- B.12 Network Radio
- B.13 Newspapers
- B.14 Magazines
- B.15 Outdoor

Data Appendix C. Policy Variables

- C.1 Recruiter Accession Objectives
- C.2 El Pay
- C.3 Recruiter Numbers

Data Appendix D. Environmental Variables

- D.1 Youth (16-19) Unemployment
- D.2 Civilian Minimum Wage

ADJUSTED OR TRANSFORMED DATA SERIES APPENDICES

Data Appendix E. Performance Variables

Accessions by Date of Contract (the December 1976 GI Bill determined spike removed from the data)

- E.1 High School Degree/Category I-III A
- E.2 High School Degree/Category IIIB-IV
- E.3 Non Degree/Category I-III A

ASVAB Exams (the December 1976 GI bill Determined spike removed from the data)

- E.4 Category I-III A
- E.5 Category IIIB-IV

Data Appendix F. Media Variables

Advertising spending (deflated to constant Dec. 1978 dollars, and adjusted to reflect net spending levels throughout)

- F.1 Television
- F.2 Radio
- F.3 Newspaper
- F.4 Outdoor
- F.5 Direct Mail
- F.6 Local Advertising
- F.7 Regular Magazines
- F.8 Special Magazines

Aggregated Advertising Spending (aggregation is over deflated net dollars)

- F.9 Total Media at Current period
- F.10 Total Media Sum of Periods T-4 through T-11
- F.11 Television (lagged 1 period) + Local Advertising  
+ Newspaper
- F.12 Total Media - Sum of Current Period Through Period T-5

Data Appendix G. Policy Variables

- G.1 Recruiter Accession Objectives - Twelve Month Centered Moving Average
- G.2 Recruiter Accession Objectives - Ratio of Monthly Objectives to Moving Average
- G.3 Relative Pay - the Ratio of EI Pay to the Civilian Minimum Wage

A STUDY OF THE EFFECTIVENESS OF  
THE ARMY'S NATIONAL ADVERTISING EXPENDITURES

VOLUME I  
EXECUTIVE SUMMARY

LIST OF TABLES

TABLE 1.	Estimated Advertising Cost Per Recruit.....	4
TABLE 2.	Relative Cost-Effectiveness of Advertising.....	5
TABLE 3.	Effect of Terminating the GI Bill.....	6
TABLE 4.	Effect of 10% Increase in Recruiting Objectives.....	6
TABLE 5.	Conversion Rate: Long-Term Averages (Monthly).....	7

LIST OF FIGURES

FIGURE 1.	The Models in Flow Chart Form.....	2
FIGURE 2.	An Extra \$1,000,000 Buys 800 Quality Accessions.....	4

A STUDY OF THE EFFECTIVENESS OF  
THE ARMY'S NATIONAL ADVERTISING EXPENDITURES

LIST OF TABLES

VOLUME II  
MAIN REPORT

TABLE 4-1.	Mental Category I-IIIA Exam Model (Pre-Advertising).....	4-4
TABLE 4-2.	Mental Category I-IIIA Exam Model.....	4-6
TABLE 4-3.	Mental Category IIIB-IV Exam Model.....	4-6
TABLE 4-4.	HSDG/CAT I-IIIA Accessions - Logarithms.....	4-10
TABLE 4-5.	HSDG/CAT IIIB-IV Accessions - Logarithms.....	4-10
TABLE 4-6.	NHSDG/CAT I-IIIA Accessions - Logarithms.....	4-10
TABLE 5-1.	Goodness of Fit.....	5-2
TABLE 6-1.	Incremental Accessions Due to Increasing Key Factors 10 5 Beyond Their 1980 Levels.....	6-2
TABLE 6-2.	Advertising Costs Per Recruit.....	6-4
TABLE 6-3.	Relative Cost Efficiencies.....	6-5
TABLE 6-4.	Effective of Increasing Total Objectives by 10%.....	6-5
TABLE 6-5.	Effect of Terminating the GI Bill.....	6-6

A STUDY OF THE EFFECTIVENESS OF  
THE ARMY'S NATIONAL ADVERTISING EXPENDITURES

LIST OF FIGURES

VOLUME II  
MAIN REPORT

FIGURE 2-1. Process Overview.....	2-3
FIGURE 2-2. The Two-Stage Process.....	2-4
FIGURE 4-1. Category I-III A Exams.....	4-2
FIGURE 4-2. The Linkage Structure.....	4-7
FIGURE 6-1. Effects of an Additional \$1.0MM in Advertising.....	

## EXECUTIVE SUMMARY

### OBJECTIVES

The principal objective of this modeling project was to measure advertising's impact on recruiting in terms of both quantity and quality of recruits. The secondary objectives were to determine the importance of the other major factors and to analyze the impact of media alternatives.

### RESULTS

The project has been successful in that these objectives have been met: advertising payout has been measured according to target group, the importance of six other factors has been quantified, and although available data was limited, some indication of media differences was developed.

### METHOD

The methodology employed followed standard econometric practices. A list of measurable variables was developed and data concerning those variables was compiled. The analysis covers the five-year period of 1976-1980.

Exam-taking by prospects was chosen as the criterion against which we directly measured advertising's effects because exam-taking occurs fairly early in the recruiting process: after the first contact with the recruit, but before the critical negotiating session between the prospect and the career counselor.

We next built models that explained the effect of the GI Bill, youth unemployment, seasonality, the minimum wage, starting pay, recruiting objectives and the number of recruiters. Two exam-taking models were built: one for the smarter than average prospect (Mental Category I-III A) and a second for the less smart prospects (Mental Category - IIIB-IV).

Once most of the variations in exam-taking were explained by these factors, we analyzed the effects of advertising on the residual exam-taking. Each advertising medium (TV, radio, etc.) was examined one at a time.

The advertising and non-advertising effects were then jointly estimated and validated. Stage I in Figure 1 summarizes these models in flow chart form. Stage II of the analyses involved linking exams to accessions. Accession records were reviewed, and each accession was allocated to the month in which the enlistment contract was signed. This is effectively a contract series, exclusive of those contracts that do not result in final accession. To our knowledge, this is the first time that recruiting performance has been measured using a criterion so far "upstream" in the recruiting process.

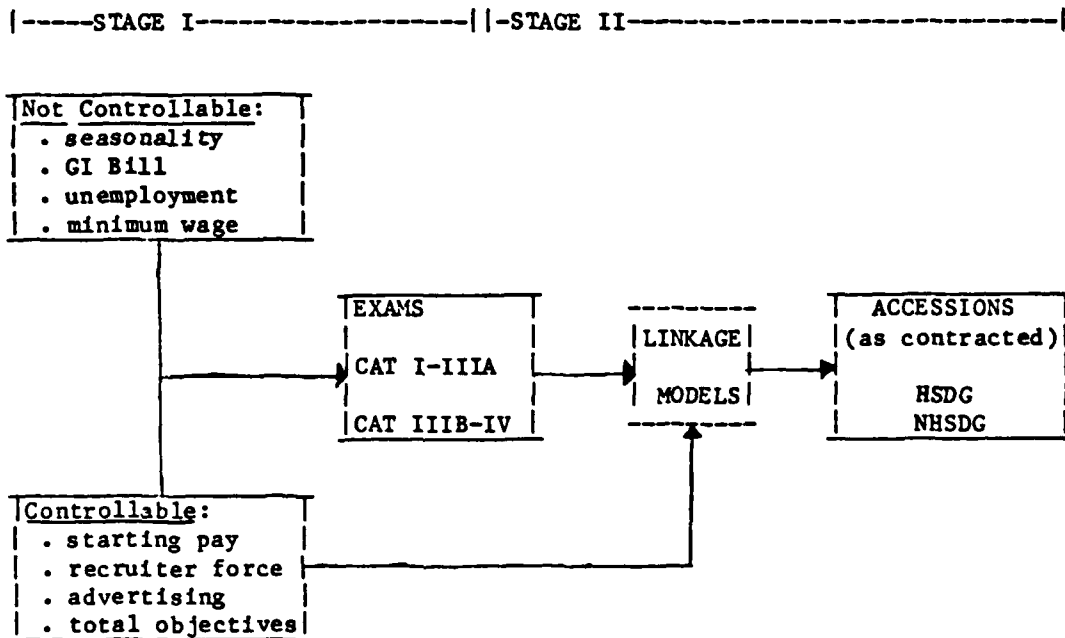

Figure 1. The Models in Flow Chart Form

## KEY FINDINGS

The key findings of the study are summarized below. In arriving at these findings we assumed that omitted variables were not dominating influences, that past (1976-1980) relationships will pers'ist, and that all factors will stay relatively close to their observed ranges.

### Advertising Effects Differ by Target Group.

Advertising effects differ by mental group. The number of recruits from each mental group that access as a result of advertising varies, as does the time lag between their exposure to advertising and their actual accession.

Some mental category I-III A prospects are affected by TV, newspaper and local advertising almost immediately (in the month of exposure or one month later), while others demonstrate a delayed response, generated by all measured media used in the campaign.

Mental category IIIB-IV prospects are affected by all media in the campaign up to five months after exposure.

### Effects Of An Extra \$1,000,000 Of Advertising.

Advertising effects on CAT IIIB, NHSDG contracts were assumed to be limited because we are offered more of such prospects than we wish to accept.\* Therefore, the effect of an extra \$1.0MM in advertising funds was calculated considering the three remaining groups: I-III A HSDG, IIIB-IV HSDG, and I-III A NHSDG. Figure 2 shows what an extra \$1,000,000 in media expenditures would have bought in 1980, and Table 1 shows the corresponding cost per recruit.

### Relative Cost-Effectiveness Of Advertising.

Advertising is a more cost-effective way of increasing quality accessions than increasing pay or increasing the number of recruiters. This conclusion follows from an economic analysis of what would have happened if we had increased each factor in the model, one at a time, to 10% above its FY 80 level, while holding all other factors at their actual FY 80 levels. The amount and cost of each 10% change, as well as the resulting incremental accessions, are seen in Table 2.

Although a 10% increase in starting pay would net twice as many recruits as incrementing advertising by the same percentage, it would be much more costly than increasing advertising. An increase in advertising is 10 times as cost-effective as an increase in starting pay, and is twice as efficient as increasing the recruiter force (for detail, see Chapter 6 in the main report).

---

\*Our objective was to measure the effects of advertising on quality accessions; therefore, we spent little time analyzing the IIIB-IV NSHSG group. This group was considered to be more constrained by the demands of the Army than by the supply of candidates, because accession variation reflects administrative pressures as much as the response to marketing efforts.

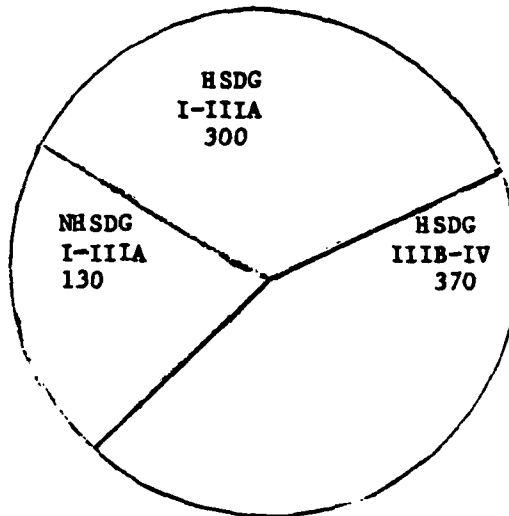

Figure 2. An Extra \$1,000,000 Buys 800 Quality Accessions

Table 1. Estimated Advertising Cost Per Recruit

<u>Market Segment</u>	<u>Cost per Recruit</u>
CAT I-IIIA, HSDG	\$ 3,300
ANY HSDG	\$ 1,500
ANY HSDG <u>or</u> CAT I-IIIA, NHSDG	\$ 1,250

Table 2. Relative Cost-Effectiveness of Advertising  
(Impact of 10% Changes)

	Amount of Change		Incremental Accessions		
	<u>change</u>	<u>cost (\$MM)</u>	<u>CAT I-III A HSDG</u>	<u>any HSDG</u>	<u>CAT I-III A, NHSDG or any HSDG</u>
Unemployment	1.7 points	--	2,400	4,200	5,200
Minimum Wage	+31¢/hr.	--	-2,300	-4,400	-5,400
Starting Pay	\$44/mo.	\$72*	2,300	4,400	5,400
Recruiter Force	533 bodies	\$16**	2,200	5,842	6,740
Total Objectives	1,100/mo.	--	-1,800	-5,200	-5,000
Advertising (in 1980 dollars)	--	\$ 3	900	2,000	2,400

\* Starting Pay Budget = \$720.0MM/year

\*\*Recruiters each cost \$30,000/year.

Effect of Terminating the G.I. Bill.

The G. I. Bill was an important recruiting tool, the termination of which had a significantly negative impact on accessions, as illustrated in Table 3.

The impact of restoring the G.I. Bill cannot be projected, however, since its termination coincided with major policy changes and budget cuts that also affected accessions. In addition, the program's 30-year history and universal awareness further complicate any attempts at predicting the effects of restoration.

Table 3. Effect of Terminating the GI Bill  
(by Market Segment)

<u>Market Segment</u>	<u>Effect on Accessions</u>
CAT I-III A, HSDG -	down 11,000/year
Any HSDG -	down 22,000/year
CAT I-III A, NHSDG or any HSDG -	down 27,000/year

Effect of Change in Total Objectives.

The model shows us that increased "pressure" via increased quantity objectives produces more exams, but fewer quality accessions, and has historically, therefore, been costly and counter-productive.

Table 4. Effect of 10% Increase in Recruiting Objectives

<u>Market Segment</u>	<u>% of change in quality accessions</u>
CAT I-III A, HSDG	- 5%
Any HSDG	-10%
Any HSDG or CAT I-III A, NHSDG	- 5%

Exams to Accessions Conversion Rate.

In the course of the linkage analysis, we noted a fairly stable exams-to-accessions conversion rate, as illustrated below. An increase in this conversion rate may well be the most cost-effective way to improve quantity and quality simultaneously. As detailed analysis is outside the scope of this contract, we suggest additional study.

Table 5. Conversion Rate: Long-Term Averages  
(Monthly)

	<u>Exams</u>	<u>Known*</u> <u>HS Status</u>	<u>Estimated*</u> <u>HS Status</u>	<u>Contracts</u>	<u>Estimated*</u> <u>"Conversion"</u>
CAT I-III A	7,000	HSDG 50%	60%	2,620	63%
		NHSDG 50%	40%	1,570	56%
CAT III B-IV	13,800	HSDG 34%	40%	3,300	60%
		NHSDG 66%	60%	3,000	N/A

\*Note that HSDG status cannot be determined prior to accession because data systems collect "years of education completed."

Model Reliability and Validation.

The model passed all of the standard tests with good results. We are confident that the major process dynamics have been correctly described. Statistical tests of the model validity have been successful: 85-90% of variances have been explained, there is no auto-correlation in exams residuals, and all "t" values are in excess of 2.0.

In addition, variables have been systematically excluded to double-check their impact, and a split-half analysis has been performed to measure the stability across time. The results show that this model is both reliable and stable and can be used for forecasting purposes.

CONCLUSIONS

All factors studied had statistically significant impacts. The impact of advertising is delayed and varies by mental category. Advertising was found to be the most cost-effective tool studied (within the range of the data).

We also found that the effects of restoring the GI Bill are not projectable, and that increasing total quantity objectives puts pressure on recruiters that is counter-productive in terms of quality. Finally, we found that the model's reliability is good.