

MICROCOPY RESOLUTION TEST CHART
NATIONAL BUREAU OF STANDARDS-1963-A

2

A132781

NAVAL POSTGRADUATE SCHOOL Monterey, California



RECEIVED
JUN 22 1983
D

THESIS

CIVILIAN RETURNS TO EARNINGS FROM
PRIOR MILITARY SERVICE

by

Orin Paul Reams, Jr.

June 1983

Thesis Advisor: G. W. Thomas

DTIC FILE COPY

Approved for public release; distribution unlimited

83 09 22 151

REPORT DOCUMENTATION PAGE		READ INSTRUCTIONS BEFORE COMPLETING FORM
1. REPORT NUMBER	2. GOVT ACCESSION NO. A132 781	3. RECIPIENT'S CATALOG NUMBER
4. TITLE (and Subtitle) Civilian Returns to Earnings from Prior Military Service		5. TYPE OF REPORT & PERIOD COVERED Master's Thesis; June 1983
7. AUTHOR(s) Orin Paul Reams, Jr.		6. PERFORMING ORG. REPORT NUMBER
9. PERFORMING ORGANIZATION NAME AND ADDRESS Naval Postgraduate School Monterey, California 93940		8. CONTRACT OR GRANT NUMBER(s)
11. CONTROLLING OFFICE NAME AND ADDRESS Naval Postgraduate School Monterey, California 93940		10. PROGRAM ELEMENT, PROJECT, TASK AREA & WORK UNIT NUMBERS
14. MONITORING AGENCY NAME & ADDRESS (if different from Controlling Office)		12. REPORT DATE June 1983
		13. NUMBER OF PAGES 150
		15. SECURITY CLASS. (of this report) UNCLASSIFIED
		15a. DECLASSIFICATION/DOWNGRADING SCHEDULE
16. DISTRIBUTION STATEMENT (of this Report) Approved for public release; distribution unlimited		
17. DISTRIBUTION STATEMENT (of the abstract entered in Block 20, if different from Report)		
18. SUPPLEMENTARY NOTES		
19. KEY WORDS (Continue on reverse side if necessary and identify by block number) Veterans post-service earnings; Economic benefits from military service; Human Capital Theory; Investment in human capital		
20. ABSTRACT (Continue on reverse side if necessary and identify by block number) → The relationship between military service and post-service earnings was analyzed using the 1980 data of the National Longitudinal Survey of young men (14 to 24 years of age in 1966). The sample was broken down by race and veteran status. Two techniques for analyzing post-service earnings were employed. Both the veteran as a dummy-variable technique and the counterfactual earnings technique predicted earnings → <i>see</i>		

disadvantages for white Vietnam-era veterans. Results for black Vietnam-era veterans were inconclusive; the veteran as a dummy-variable technique predicted significantly large premiums for veteran status, while the counterfactual earnings equations yielded inconsistent predictions. In sum, the military was found to be an ineffective method of investment in human capital for whites, while the results for black were inconclusive.

Accession For	
DATE	11
TIME	11
BY	11
DESCRIPTION	

COPY MADE BY

A

Approved for public release; distribution unlimited

Civilian Returns to Earnings from Prior Military Service

by

Orin Paul Reams, Jr.
Lieutenant, United States Navy
B.S., University of the State of New York, Albany, 1977

Submitted in partial fulfillment of the
requirements for the degree of

MASTER OF SCIENCE IN MANAGEMENT

from the

NAVAL POSTGRADUATE SCHOOL
June 1983

Author:

Orin Paul Reams

Approved by:

George W. Thomas

Thesis Advisor

Julius R. Friedman

Thesis Co-Advisor

Richard D. Estes

Chairman, Department of Administrative Sciences

Kenneth T. Marshall

Dean of Information and Policy Sciences

ABSTRACT

The relationship between military service and post-service earnings was analyzed using the 1980 data of the National Longitudinal Survey of young men (14 to 24 years of age in 1966). The sample was broken down by race and veteran status. Two techniques for analyzing post-service earnings were employed. Both the veteran as a dummy-variable technique and the counterfactual earnings technique predicted earnings disadvantages for white Vietnam-era veterans. Results for black Vietnam-era veterans were inconclusive; the veteran as a dummy-variable technique predicted significantly large premiums for veteran status, while the counterfactual earnings equations yielded inconsistent predictions. In sum, the military was found to be an ineffective method of investment in human capital for whites, while the results for blacks were inconclusive.

TABLE OF CONTENTS

I.	INTRODUCTION-----	13
A.	INTRODUCTION-----	13
B.	HUMAN CAPITAL THEORY-----	16
C.	BRIEF REVIEW OF PAST STUDIES-----	17
1.	Cutright (1972)-----	17
2.	Norrblom (1976)-----	18
3.	University of Texas Studies-----	18
4.	Little and Fredland (1980)-----	19
5.	DeTray (1980)-----	20
6.	Bolin, Hess and Little (1980)-----	20
7.	Summary of Past Studies-----	20
D.	MORE RECENT STUDIES REVIEWED-----	24
1.	Hess (1980)-----	24
2.	Bolin (1980)-----	28
3.	Fredland and Little (1980)-----	32
4.	Fredland and Little (1979)-----	34
5.	DeTray (1982)-----	36
6.	Danzon (1980)-----	39
7.	Cooper (1981)-----	41
8.	Summary-----	42
II.	ANALYSIS METHODOLOGY, DATA BASE, AND SAMPLE SELECTION-----	46
A.	INTRODUCTION-----	46
B.	DISTRIBUTION OF EARNINGS FACTORS-----	46
1.	Individual Traits-----	48

2.	Family Characteristics-----	49
3.	Personal Characteristics-----	50
4.	Job Environment-----	50
C.	DETERMINING THE EFFECTS OF MILITARY SERVICE AS AN EARNINGS FACTOR-----	52
D.	DATA BASE-----	54
E.	SAMPLE SELECTION-----	55
F.	SUMMARY-----	61
III.	EARNINGS AND EARNINGS FACTORS-----	62
A.	INTRODUCTION-----	62
1.	Analysis of Variance-----	62
2.	Chi-square Test-----	63
3.	Kolmogorov-Smirnov Test-----	63
B.	EARNINGS MEASURES-----	64
1.	Hourly Rate of Pay-----	64
2.	Annual Wages and Salary-----	64
C.	CANDIDATE EARNINGS FACTORS-----	64
1.	Age in 1980-----	65
2.	Intelligence-----	65
3.	Health-----	65
4.	Marital Status-----	66
5.	Number of Dependents-----	66
6.	Socioeconomic Status-----	67
7.	Education-----	67
8.	Training-----	68
9.	Hours Worked Per Week-----	69

10.	Weeks Employed During the Year-----	69
11.	Tenure-----	69
12.	Number of Previous Employers-----	69
13.	Union Membership-----	70
14.	Collective Bargaining-----	70
15.	Community Unemployment Rate-----	71
16.	Region-----	71
17.	SMSA-----	71
D.	SUMMARY-----	72
IV.	EARNINGS EQUATIONS-----	75
A.	REGRESSION ANALYSIS WITH VETERAN STATUS-----	75
1.	Introduction-----	75
2.	The Models-----	76
3.	Results of the Models-----	81
a.	Blacks-----	81
b.	Whites-----	84
4.	Summary-----	84
B.	EARNINGS EQUATIONS FOR WHITE VETERANS AND NON-VETERANS-----	87
1.	Introduction-----	87
2.	The Models-----	87
3.	Results of the Analyzes-----	88
a.	Veterans-----	92
b.	Non-veterans-----	92
c.	Summary for White Earnings Equations-----	93

4. Predicting Earnings-----	93
C. EARNINGS EQUATIONS FOR BLACK VETERANS AND NON-VETERANS-----	96
1. Introduction-----	96
2. The Models-----	96
3. Results of the Analyzes-----	96
a. Veterans-----	100
b. Non-veterans-----	100
c. Summary for Black Earnings Equations-----	100
4. Predicting Earnings-----	101
D. SUMMARY-----	103
V. SUMMARY, CONCLUSIONS, AND RECOMMENDATIONS-----	106
A. SUMMARY-----	106
B. CONCLUSIONS-----	109
C. RECOMMENDATIONS-----	110
APPENDIX A - HOURLY RATE OF PAY BY VETERAN STATUS BY RACE-----	112
APPENDIX B - ANNUAL INCOME BY VETERAN STATUS BY RACE-----	114
APPENDIX C - AGE BY VETERAN STATUS BY RACE-----	116
APPENDIX D - IQ SCORE BY VETERAN STATUS BY RACE-----	118
APPENDIX E - HEALTH BY VETERAN STATUS BY RACE-----	120
APPENDIX F - MARITAL STATUS BY VETERAN BY RACE-----	121
APPENDIX G - NUMBER OF DEPENDENTS BY VETERAN STATUS BY RACE-----	123
APPENDIX H - SOCIOECONOMIC STATUS BY VETERAN STATUS BY RACE-----	125

APPENDIX I - EDUCATION BY VETERAN STATUS BY RACE-----	127
APPENDIX J - TRAINING BY VETERAN STATUS BY RACE-----	129
APPENDIX K - HOURS WORKED PER WEEK BY VETERAN STATUS BY RACE-----	132
APPENDIX L - WEEKS EMPLOYED BY VETERAN STATUS BY RACE--	134
APPENDIX M - TENURE BY VETERAN STATUS BY RACE-----	136
APPENDIX N - NUMBER OF EMPLOYERS BY VETERAN STATUS BY RACE-----	140
APPENDIX O - UNION MEMBERSHIP BY VETERAN STATUS BY RACE-----	142
APPENDIX P - COLLECTIVE BARGAINING BY VETERAN STATUS BY RACE-----	143
APPENDIX Q - UNEMPLOYMENT RATE BY VETERAN STATUS BY RACE-----	144
APPENDIX R - REGION BY VETERAN STATUS BY RACE-----	146
APPENDIX S - SMSA BY VETERAN STATUS BY RACE-----	147
LIST OF REFERENCES-----	148
INITIAL DISTRIBUTION LIST-----	150

LIST OF TABLES

1.	A SUMMARY OF PAST STUDIES REVIEWED-----	21
2.	VARIABLES USED IN STUDIES REVIEWED-----	23
3.	A SYNOPSIS OF MORE RECENT STUDIES REVIEWED-----	43
4.	VARIABLES USED IN MORE RECENT STUDIES REVIEWED----	44
5.	CANDIDATE EARNINGS FACTORS-----	63
6.	SUMMARY OF EARNINGS AND EARNINGS FACTORS TEST RESULTS-----	73
7.	REGRESSION MODEL VARIABLES FOR BLACKS AND WHITES-----	78
8.	CORRELATION COEFFICIENTS OF EARNINGS FACTORS FOR BLACKS WITH SALARY AND LN SALARY-----	79
9.	CORRELATION COEFFICIENTS OF EARNINGS FACTORS FOR WHITES WITH SALARY AND LN SALARY-----	80
10.	EARNINGS EQUATIONS FOR BLACKS-----	82
11.	EARNINGS EQUATIONS FOR WHITES-----	83
12.	REGRESSION MODEL VARIABLES FOR BLACKS AND WHITES, VETERANS AND NON-VETERANS-----	88
13.	CORRELATION COEFFICIENTS OF EARNINGS FACTORS FOR WHITE VETERANS AND NON-VETERANS WITH SALARY AND LN SALARY-----	89
14.	EARNINGS EQUATIONS FOR WHITE VETERANS-----	90
15.	EARNINGS EQUATIONS FOR WHITE NON-VETERANS-----	91
16.	EARNINGS PREDICTION RESULTS FOR WHITE VETERANS AND NON-VETERANS-----	94
17.	CORRELATION COEFFICIENTS OF EARNINGS FACTORS FOR BLACK VETERANS AND NON-VETERANS WITH SALARY AND LN SALARY-----	97
18.	EARNINGS EQUATION FOR BLACK VETERANS-----	98

19.	EARNINGS EQUATION FOR BLACK NON-VETERANS-----	99
20.	EARNINGS PREDICTION RESULTS FOR BLACK VETERANS AND NON-VETERANS-----	101

LIST OF FIGURES

1. Earnings Factors by Category-----	48
2. Draft-Era Former Enlisted Veteran Criteria Applied-----	59
3. Final Sample: Draft-Era Former Enlisted Veteran and Full-Employment Criteria Applied-----	60

I. INTRODUCTION

A. INTRODUCTION

The Department of Defense (DoD) is the largest employer of young men and women in the United States. The Military Manpower Task Force's Report to the President (1982) noted that annual accessions averaged 341,000 for FY1977-1981, and that an average of 333,000 annual accessions were planned for FY1982-1987. The vast majority of each year's new accessions are young people, age 17 to 21. Entry into the armed forces is a significant step in the life for virtually all of these young people and is perceived by many to be an investment in their future since training and job experience are stressed by military recruiters as advantages that the services readily offer.

After the nation's public education system, the military training organization is the largest training system in the United States. The DoD request for funds needed to support individual training in FY1982 totaled 10.52 billion dollars. The DoD Military Manpower Training Report for FY1982 went on to indicate that at any one time, 18 percent of the authorized end strength of the active duty armed forces are involved in individual training as either instructors, students, instructional support, or base operating support.

Gay (1978) found that over ninety percent of new accessions undergo a formal course of instruction in their specialized military occupation. Clark and Sloan (1964) state that 85 percent of all enlisted job specialities have a direct civilian application and 60 percent of all military training and education had direct application to civilian life. It is important to the potential enlistee and military recruiters to know if the armed forces are able to provide valuable job training and experience and what effect military service has on lifetime civilian earnings. Equally important to the draftee is the effect that military service has on "his" lifetime civilian earnings.

The supply of 17 to 21 year old males is projected to decline from 10.8 million in 1980 to 9.0 million in 1990. Economic as well as demographic trends may make it difficult for the armed forces to attract the quality and the quantity of young people needed. Increases in pecuniary and non-pecuniary benefits would be required in order for the armed forces to remain competitive in the labor market.

Any discussion concerning the reintroduction of the draft or national service to meet the armed force's manpower needs in peacetime, must include those economic and social issues of "who serves when all don't" and what is the "imputed tax or benefit to those who serve". Studies begun in the 1960's to estimate the benefits of military service were part of the conscription versus All Volunteer Force debate. Many of

these studies found military service to have a negative earnings effect. Later studies, Little and Fredland (1979), Martindale and Poston (1979), and Lapreato and Poston (1977) found socioeconomic benefits accruing to veterans. However, these benefits were observed to mainly accrue to minority veterans who had used their military training to improve their socioeconomic status.

This thesis tests the hypothesis that the civilian earnings differential from prior military service is a benefit obtained from the investment in human capital in much the same way as training and job experience are in the civilian sector. This thesis examined the differences in civilian earnings of sample members who were full-time employees, and who had either never served in the armed forces or had successfully completed one term of military service during the draft-era. While other studies have attempted to measure the benefits of general or specific military training, this thesis is concerned with determining the value of having served, the summation of that veteran's military experience.

Human capital theory, the theory on which this thesis is based is briefly reviewed in this chapter. A review of past and more recent studies are also contained in Chapter I. Chapter II details the analysis methodology, data base and sample selection criteria used in the thesis. Chapter III identifies and describes candidate earnings factors and earnings measures. Chapter IV tests the hypothesis by

determining earnings equations from multiple regression analysis to ascertain the economic returns to veteran status. The last chapter lists the summary, conclusions and recommendations of the thesis.

B. HUMAN CAPITAL THEORY

Human capital theory attempts to explain the differences in individual wages as a function of factors that represent an investment in a person. An investment in human capital could be education, training, military service, tenure or any other factor that could enhance an individual's productivity.

Becker's (1975) analysis of costs and benefits (return on investment) of human capital is a popular and analytic method of examining the effects of human capital formation. Becker concluded the following from his analysis of human capital theory:

1. Earnings increase with age at a decreasing rate. The rate of increase is positively related to the level of skill.
2. Unemployment rates are inversely related to skill levels.
3. The distribution of income is positively skewed especially for professional and skilled workers.
4. The more able people are, the more education and training they receive.

A number of studies have been undertaken to analyze the effects of military service on civilian earnings. These studies may be characterized as having diversity in their results, methods, earnings measures, earnings factors, time horizons, and periods of observation. In short, there is no consensus on the relationship of civilian earnings to prior military service.

C. BRIEF REVIEW OF PAST STUDIES

Studies previously examined by Chamarette (1981) are briefly reviewed here.

1. Cutright (1972)

Cutright's work, titled "Achievement, Mobility, and the Draft: Their Impact of the Earnings of Men", sought to explain positive effects on civilian earnings from military service. He identified five factors that might account for any positive influence: veterans from the south were less likely to return home for the lower wages being paid in the south, an honorable discharge influenced employers to hire veterans, some men would receive valuable in-service vocational training that normally wouldn't have, the G.I. Bill, and all the intangibles one would receive from just having served in the armed forces.

Cutright's sample was composed of men who were draftees and non-veterans born between 1927 and 1934. He concluded that the earnings of veterans were not higher

than non-veterans when controlling for intelligence and that being away from the labor market for an extended period of time would tend to lower earnings in later periods.

2. Norrblom (1976)

"The Returns to Military and Civilian Training", investigated the effects that formal in-service vocational training and on-the-job (OJT) training had on wages in a related civilian occupation.

Her conclusions were that formal vocational training had a positive correlation with civilian earnings while OJT had no correlation. Norrblom's study included only veterans, therefore no comparison between veterans and non-veterans could be made to determine benefits from military training.

3. University of Texas Studies

Three articles --by Browning, Lapreato and Poston (1973), "Income and Veteran's Status: Variations Among Mexican Americans, Blacks and Anglos", American Sociological Review; by Lapreato and Poston (1977), "Differences in Earnings and Earnings Ability Between Black Veterans and Non-veterans in the United States", Social Science Quarterly; and by Martindale and Poston (1979), "Variations in Veteran/ Non-veteran Earnings Patterns Among World War II, Korea, and the Vietnam War Cohorts", Armed Forces and Society--proposed that military service provided a "bridging environment" for

minority groups that resulted in socio-economic advantages after release from active duty.

Their studies submit that military experience is a crucial determinant in obtaining better paying civilian jobs; minority veterans earned more than minority non-veterans for all three war-era cohorts, while white veterans of the Vietnam era earned less than non-veterans. Their studies did not account for tenure and training, variables that would largely impact earnings abilities.

4. Little and Fredland (1980)

Their article, "Veteran Status, Earnings, and Race: Some Long Term Results", Armed Forces and Society concluded that veterans had significantly higher average earnings than non-veterans regardless of race. They hypothesized that military service is in itself a general training variable and an investment in human capital that contributes to civilian earnings. Their data base was the 1966 National Longitudinal Survey (NLS) for men, age 45 to 59 in 1966.

Since these veterans are largely from the World War II and Korean era, their findings must be qualified. World War II veterans served in an era where there was no draft deferments for college and little draft avoidance; these veterans came home to an appreciative society, generous G.I. Bill benefits and a period of robust economic activity. Their study examines one year in the lives of veterans and non-veterans, lifetime benefits to veterans could therefore not be claimed.

5. DeTray (1980)

DeTray's "Veteran Status and Civilian Earnings" concluded that veterans earn more than non-veterans and that training received in the military increases civilian wages. He used the 1971 NLS data set for young men, 14 to 24 years old in 1966. Veteran status criteria was loosely defined; an individual who indicated they had served for one month or forty-eight or any other length of time was assigned veteran status.

6. Bolin, Hess, & Little (1980)

Their article entitled, "Military Vocational Training: Its Impact on the Post-Service Earnings Path" indicated there were no positive economic benefits to be gained from military vocational training in the short run. Veterans who received no in-service vocational training have a negative earnings effect from military service. These individuals might have done better to not have joined at all but to have used that time to work for a civilian employer and gain tenure.

He used the NLS data set of young men, 14 to 24 years old in 1966 for the survey years 1969 and 1971. DeTray and Bolin et al. used the same data set to arrive at differing conclusions concerning returns to veterans.

7. Summary of Past Studies

Table 1 is a short summary of past studies previously reviewed by Chamarette (1981) and briefly reviewed here. Table 2 is a listing of variables considered in these past studies.

TABLE 1
A SUMMARY OF PAST STUDIES REVIEWED

AUTHORS, DATE AND PURPOSE	METHODOLOGY	RESULTS AND CONCLUSIONS
1. Cutright 1972 Analyze the determinants of earnings and measure the effects of military svc on civilian earnings.	Compared Army vets and non-vets. Controlling for age, education, race and IQ.	Earnings of vets are not higher than comparable non-vets.
2. Norrblom 1976 Examines the economic effect of formal and OJT military training acquired in the military.	Regression analysis semi log function. No comparison of vets/non-vets was made.	Formal vocational training has a positive effect on post service earnings.
3. Browning, Lopreato, & Poston 1973 Study effects of military service for minority men on civilian earnings.	Comparison of mean incomes controlling for race, education, and occupation.	Minority vets earn more than minority non-vets, supporting the bridging environment hypothesis.
4. Lopreato & Poston 1977 Study effects of bridging hypothesis of military service.	Compares earnings after regression analyses by vet status. Controlling for education, age and employment.	Black vets are better able to convert educational attainment into earnings advantages than black non-vets
5. Martindale & Poston 1979 Examines earning patterns for 3 groups of vets & non-vets.	Compares earnings after regression analyses by vet status. Controlling for education, employment, marital status, race.	Blacks and Mexican Americans are better able to convert characteristics into higher earnings than non-vets.

TABLE 1 (CONT.)

AUTHORS, DATE AND PURPOSE	METHODOLOGY	RESULTS AND CONCLUSIONS
<p>6. Little & Fredland 1979 Examines earnings of vets/non-vets some 20 years after most served.</p>	<p>Cross-sectional study utilizing regression analyses controlling for many factors that contribute to earnings.</p>	<p>Vets had a 5 to 10% premium on earnings.</p>
<p>7. DeTray 1980 Examines earnings differences between vets/non-vets.</p>	<p>Cross-sectional study utilizing regression analyses controlling for many factors that contribute to earnings.</p>	<p>Vets earn more than non-vets. Training received in the military increases civilian wages.</p>
<p>8. Bolin, Hess, & Little 1980 Utilizes human capital approach to compare the values of vocational- al training over time.</p>	<p>Regression analyses controlling for many factors that contribute to earnings, in particular the use of civilian and military training.</p>	<p>Use of military training doesn't have a positive effect. Vets with no in-service vocational trainings have a negative earnings effect from military service.</p>

TABLE 2
VARIABLES USED IN STUDIES REVIEWED

EXPLANATORY VARIABLES	CUTRIGHT	NORRELOM	BROWING	LOPREATO	MARTINDALE	LITTLE	DETRAY	BOLIN
	1972	1976	et al. 1973	et al. 1977	et al. 1979	et al. 1979	1980	et al. 1980
Age	X	X	X	X	X	X	X	X
Education	X	X	X	X	X	X	X	X
IQ/AFQT	X	X						X
Married or Dependents		X			X			X
Residence-Geographic	X	X	X	X	X		X	
SMSA							X	X
Comparison of Civilian Job		X	X					
Veteran vs Non-Veteran	X		X	X	X		X	X
Use of Military Training		X				X		X
Duncan Index						X		
Tenure						X	X	X
Experience							X	
Race	X	X	X	X	X	X		X
Health							X	X
Vocational Training							X	X
<u>EARNINGS MEASURES</u>								
Earnings from Wages and Salaries	X		X	X	X	X		X
Hourly Earnings		X					X	X

As Cutright (1972) and Martindale, et al. (1979) point out, a selection bias in the veteran sample arises from the political and socio-economic climate at the time of enlistment and the time of discharge may markedly influence post service employment opportunities.

Since all studies use cross-sectional or limited longitudinal analysis to investigate benefits from military service or non-military service, they cannot indicate lifetime benefits but only serve to give an indication of any benefit. Longitudinal data tracing earnings profiles of individuals would need to be analyzed to determine lifetime benefits.

D. MORE RECENT STUDIES REVIEWED

1. Hess (1980)

Hess' article "From School To Work Via Military Service: An Improved Transition" examined the value of military service to entry into civilian employment. Job entry characteristics were analyzed to determine differences between veterans and non-veterans.

The National Longitudinal Survey (NLS) of young men, aged 14 to 24 in 1966 for the survey years 1966 to 1973 (except 1972 when no survey was conducted) was utilized. Cohort members were grouped by veteran status and race. To be identified as a veteran an individual must have served at least six months.

In order to test the five hypotheses listed below, eleven job entry characteristics were tested by discriminant analysis to denote statistically significant differences between veterans and non-veterans at initial entry into full-time jobs occurring each of the survey years. Five variables (age, highest grade completed, socioeconomic background, intelligence quotient and payrate) were deemed to be important and underwent longitudinal analysis to determine any systematic relationships.

In addition to the grouping of cohort members by race and veteran status, members were further grouped by region and age: all men over 16 years of age, all men over 16 who were residents of the South, all men over 16 who weren't residents of the South, and all men 20 to 24 in a survey year.

The five hypotheses were as follows:

Hypothesis one: Military service provides benefits of increased productivity, maturity, and experience that pay-off for veterans at civilian job entry. Even though non-veterans had attained higher levels of education, educational ability (IQ) and come from higher rated socioeconomic backgrounds, veterans were found to enjoy significant entry-level payrate advantages over non-veterans. But this advantage was less obvious during the 1970-1973 time frame when there was an economic slowdown.

Hypothesis two: Military service provides a screen or certification that identifies veterans as "credentialed" job seekers. During periods of economic uncertainty and recession (1970-1973) veterans fared no better than non-veterans in obtaining jobs. However, during periods of economic activity (1966-1969) Hess' findings support the hypothesis that veterans obtained jobs more readily than non-veterans.

Hypothesis three: The workforce is partitioned for veterans and non-veterans according to occupational and industrial structure and payrates. The workforce was found to not be partitioned by veteran and non-veteran status.

Hypothesis four: Veterans exhibited different relationships from non-veterans in the areas of marital status and school participation. Veterans were more likely to be married than non-veterans, but when countrolling for age, little difference could be found. There was little support for the hypothesis in school participation until the later survey years when white veteran school participation increased. This increase is considered a result of the boost to the G.I. Bill monetary benefits in the early 1970's. But results are not totally conclusive since black veteran school participation rates lagged behind the increased rates for white veterans in the later survey years.

Hypothesis five: In transition from school to work, the armed forces provided upward mobility to veterans after they leave the service and enter the civilian labor force. Hess' points to the following evidence to support the hypothesis. Veteran labor force participation rates were found to be high even as the jobless rate increased in the labor force. Veterans were found to gain the same percentages of jobs in the various entry-level occupations and industries with higher entry-level payrates than non-veterans who averaged higher levels of education.

Although black veterans were comparable to black non-veterans in every area except age and marital status, they were found to have entry-level payrates and percentages in occupations and industries that approached those of whites.

During the years of economic slowdown and high unemployment experienced in 1970 to 1973, veterans were found to enjoy the advantages described in hypothesis one, two, and five to a much lesser degree or not at all.

Hess examined the differences in personal and job characteristics for initial entrants into the civilian job force for the years 1966, 1967, 1968, 1969, 1970, 1971, and 1973 by various categories of men. Unfortunately (and often unavoidable) the data set used in the analysis didn't provide large numbers of individuals to be categorized by veteran status by race by region by age. The number of black veteran new workers never exceeded 6 for each year from 1966 to 1970

and 15 for the years 1971 and 1973. To categorize these black veteran new workers further by region (South/Nonsouth) is to cut this already small number in half, leaving as few as three in each cell in some cases.

By identifying an individual who may have served little more than six months as a veteran, Hess has used a too inclusive a criterion to identify those individuals who may have received civilian employment benefits from military service. Hess' paper is an important step in understanding the significance of benefits veterans are perceived to enjoy in the labor market.

2. Bolin (1980)

Bolin's paper "Military Service and Military Vocational Training Effects On Post-Service Earnings" examined the first year (and a period of time thereafter) of civilian work experience of veterans and non-veterans. The NLS data set of young men, aged 14 to 24 in 1966 for the survey years 1966 to 1973, was utilized.

Cohort members who entered the civilian labor market for the first time in a survey year were grouped into the following categories:

- a. Military user, those individuals who had received in-service vocational training and used that training on their civilian job.
- b. Military non-user, those who had never used their in-service vocational training on a civilian job.

c. Military non-taker, those who had not received any military training beyond basic entry training.

d. Non-military user, those who had completed some civilian vocational training which they used in a job.

e. Non-military non-user, those who had completed some civilian vocational training but never used the training on a later civilian job.

f. Non-military non-taker, were those individuals who had never completed any civilian vocational training.

Non-military were those individuals who had never served in the military, while those described as having been in the military had to have served at least six months. The final sample selected was 2262 of which 552 were veterans.

Longitudinal analysis was conducted by comparing year group 1966's labor market behavior and wages to their 1972 behavior and wages. Additionally, comparisons were made between the labor market behavior and wages of year group 1966 and with the incremental increase to the total for each succeeding year group (1967 through 1971) for selected years.

Discrimant analysis was performed to determine if the training groups: user, non-user, and non-taker could be distinguished from one another. Bolin found that military user and military non-user could not be distinguished from one another. Also, the non-taker groups were quite similar while the two non-user groups were significantly different.

Bolin concluded that when individuals are grouped according to their propensity to use their training (military user and non-military user) neither military service nor military vocational training was shown to have made a significant contribution to the human capital investment over the time period examined, six years.

Individuals who did not receive military training were found to have lower earnings than non-veterans who also received no vocational training. Bolin submits that these individuals suffer a post-service loss due to military service. Due to the fact that these individuals gave up the ability to accumulate tenure with a civilian employer by serving in the military.

When Bolin further defined the sample by IQ levels he determined that neither military service nor military vocational training showed a significant contribution to human capital formation. Vocational training within the military is just another source of training that an individual may choose. In an expanding economy, more highly educated individuals may forgo vocational training to enter the labor market.

Vocational training whether gained from the military or civilian community is beneficial to the individual, the more recent the training - the more beneficial. Bolin found evidence to support the hypothesis that employers use the military as a hiring screen for the individual's first job.

Bolin stated that when he compared veterans and non-veterans as two separate groups, military service resulted in an earnings premium. However, since the non-military group had a larger number of individuals who undertook no vocational training (51 percent of non-military to 23 percent for veterans) that this may not be a realistic group for comparison with veterans. If one is interested in examining the effects of military vocational training and military service on post-service earnings, one needs to capture the effect of any premium or costs to all veterans when compared to the alternative - not having served, and possibly being in the high percentage (who were sampled) who do not undergo vocational training in the civilian sector before their first job.

Bolin did not point out that the mean wages for non-users is significantly higher for veterans than non-veterans. Military non-users compose 57 percent of the veteran group compared to 12 percent for non-military non-users. The difference in mean wages between military non-users and non-military non-users is greater than the differences between military and non-military users.

Bolin labeled any training received in the military (after basic training) as vocational training while much of the training might have little direct application in the civilian labor market, and ignored the possible indication that an even greater proportion of veterans enjoyed a

premium from having served even though their military training may not be utilized on their civilian job.

3. Fredland and Little (1980)

Fredland and Little's article, "Long-Term Returns To Vocational Training: Evidence From Military Sources", investigated returns to earnings of men who received military vocational training in World War II and shortly thereafter. The authors used the NLS data set for men, aged 45 to 59 in 1966. Whites who were 45 to 49 in 1966 were selected for the analysis, this group of men were the predominant recipients of military vocational training during the World War II era.

Regression analysis was conducted to explain income differences, the dependent variables used were: (1) 1966 wages and salaries (2) 1966 hourly rate of pay (3) 1966 earned income. To test the effects of vocational education, workers were classified as users of training, non-users of training received and non-takers of training.

A set of seven dummy variables were used to capture any premium that might occur as a result of training:

- a. user of military vocational education
- b. user of civilian vocational education
- c. user of both
- d. non-using taker of military vocational education
- e. non-using taker of civilian vocational education

- f. non-using taker of both
- g. military service.

Dummy variables were added to account for those individuals who don't use their vocational education on the job because the authors felt that the investment has general application as well as job specific application. The rigors of training are believed to increase the individual's productivity even though the training may not be specifically used on the job.

To test the influence of military service for those who received no vocational training, a dummy variable for military service was included. Five control variables were also used in the equation: tenure, education, South/Non-south, blue collar occupation, and the Duncan index for the respondent's father.

Additionally, regression analysis was conducted to determine what type of training received and used on the job is the most productive for the individual. Three categories are used for both civilian and military trained individuals: professional and managerial, skilled manual, and all others.

The results for users of civilian vocational training are similar to those of armed forces training, but larger and more significant in each case. Those who received civilian or military training but do not use it, earn no premium for that training.

Coefficients for armed forces training of a professional or managerial nature were found to be positive and significant. While those of civilian professional and managerial training were positive but smaller and less significant.

The coefficients for skilled manual training show large, highly significant premiums for those who received and used civilian training but not for those who received and used this type of training from the military. The results for the other training category were all insignificant.

In summary, the authors noted that military and civilian vocational training yield a premium to long-term earnings for those who use such training on the job, but not for those who don't use it. Although results indicate civilian training is more important than military training, the results must be qualified. Civilian training is more completely transferrable to a civilian job than military training. All military training was conducted 15 to 20 years prior to 1966, when earnings were observed for individuals. Civilian training could have been received anytime prior to 1966, the survey year.

4. Fredland and Little (1979)

Their article titled, "World War II Veterans: Pecuniary and Non-Pecuniary Returns To Service", investigated specific attributes of the bridging hypothesis by comparing groups of white and black veterans with their contemporaries

who did not serve. The data set used was the NLS of men, aged 45 to 59 in 1966.

Elements of the bridging hypothesis, or their proxies, are examined to determine if veterans fare better than non-veterans in each of the following:

- a. educational attainment--grade of school completed.
- b. geographical mobility--determines if their present job is in a different location (SMSA, state or region) than their first job.
- c. personal independence--measured from the Rotter scale.
- d. experience dealing with bureaucracies--employment in government.
- e. work ethos--attitude toward his job.

First, regression analyses utilizing a basic human capital equation with a military service variable was conducted to determine effects of military service on wages and the Duncan index. The authors found that the military service of some 20 years earlier is both a significant determinant of 1966 wages and Duncan index for whites, and of 1966 wages for blacks.

Next, differences in mean values for the bridging variables were determined and tested for significance. Only employment in government and grade of school completed were found to be statistically different between veterans and non-veterans, they were both greater for veterans. In

addition, black veterans were found to have a higher work ethos percentage than black non-veterans.

To determine if veterans who possess bridging characteristics convert them into significant determinants of income or socioeconomic status, regression analysis was conducted with the bridging hypothesis variables.

The results for black veterans were clear - bridging characteristics were not significant, one-half of the coefficients were negative. White veterans were able to convert their education into significantly higher incomes, and their government employment into significantly higher socioeconomic status.

Fredland and Little conclude that their tests can not confirm the acceptance of a broad general statement of a bridging hypothesis that can explain the income differences between veterans and non-veterans in the long-run. They do point out that educational differences are important, but occupational choice and other labor market factors need further investigation.

5. DeTray (1982)

DeTray's article, "Veteran Status as a Screening Device" that appeared in the American Economic Review tested the proposition that civilian employers use veteran status as a productivity screen. Human capital investment theory hasn't been able to totally account for earnings

differences noted between veterans and non-veterans. DeTray offers empirical analysis suggesting that military service does provide civilian employers with valuable information on worker productivity.

Three hypothesis are offered to account for the proposition that employers distinguish between high and low productivity workers by knowing an individual's veteran status.

Hypothesis 1: Other things being equal, the effect of veteran status on civilian earnings will be a positive function of the proportion of men in a given population who claim veteran status.

Data used to test all hypotheses came from the 1960 and 1970 1-in-100 Census Public Use samples and consisted of equal numbers of white and black men, age 22 to 65. To test hypothesis 1, regression analyses was conducted on the logarithmic function of hourly rate of pay to determine the coefficient for veteran status in eleven four-year age groups while controlling for age, education, and residence (SMSA, region). From a total of 44 earnings equations, eleven each for surveys of 1960 and 1970 blacks and whites, nearly 3/4 of the equations resulted in positive coefficients for veteran status.

The veteran status coefficients from each age group were regressed on the proportion of men claiming veteran status in each group. All equations indicated a positive

relationship between the veteran sample group and the effect of veteran status on civilian wages, they were statistically significant for each group except 1970 blacks.

To gain an insight into the range of effectiveness that the veteran screen may have, hypotheses two and three were tested. An example of the coarseness the veteran screen might produce would be the perceived differences veteran status might hold for an employer who must select one from each group: two college graduates (one a veteran) and a group of two high school dropouts (one a veteran).

Hypothesis 2: Because the quality of schooling varies more for blacks than for whites, veteran status will be a more useful screen for blacks than for whites.

Hypothesis 3: Other things equal, the premium to veteran status will diminish as schooling levels rise.

The relationship between schooling and veteran premium was tested by regrouping the eleven four-year age group samples into two schooling levels, 0-11 and 12 plus and recalculating the relationship between the veteran premium and proportion veteran. For all four race/census year groups, veteran status was found to yield higher premiums to men with less than 12 years of schooling than those with 12 or more.

DeTray concluded that although veteran status acts as a valuable screening process it cannot, alone, account for the different wage premiums received by veterans of different ages.

The author points out the importance that an honorable discharge might hold for a perspective employer of a veteran, but nowhere in his article does he describe the criteria used to classify individuals as veterans.

The variables used in the multiple regression analyses were limited to age, education and residence. Important variables often used in human capital earnings equations were not used, such as tenure and training. Perhaps the optimal method to determine if the veteran screening proposition is an important benefit to veterans is to use those variables from established human capital theory to arrive at a more precise coefficients for veteran status. DeTray concluded that the veteran screening process couldn't account for all of the differences in earnings between veterans and non-veterans, then both human capital investment and veteran screening must be taken into account simultaneously.

6. Danzon (1980)

The report "Civilian Earnings of Military Retirees" used the Public Use samples of the 1970 Census to examine the second career earnings loss of military retirees. Civilian earnings of military retirees were compared to those of noncareer veterans. The analysis was limited to men who retired between 1964 and 1969 and were less than 60 years old in 1969. Additionally, sample criterion included: blacks and whites, eight years or more of schooling completed, 1969

earnings of \$500 or more, worked 27 weeks or more in 1969 and residents of the continental U.S.

Multivariate regression analysis was conducted to estimate what extent job characteristics can be attributed to earnings differences between retirees and noncareer veterans. There was no minimum time period criterion applied to veteran status.

The results indicated, on average, weekly wages of retirees are typically 10 to 20 percent lower than those of noncareer veterans. Differences vary by race and level of schooling. Among whites, the differences is smaller for high school dropouts than high school or college graduates. For blacks the differences were smaller than for whites and often were found to favor black veterans.

There were two reasons proposed why the results shouldn't immediately be interpreted as evidence measuring the extent of second career earnings loss. Retirees were seen to have made choices to reduce their nominal earnings but not necessarily real income by not working as many hours as noncareer veterans and living in different locations (predominantly in the South and the West). Half of the earnings differential can be attributed to differences in job-related characteristics.

7. Cooper (1981)

Cooper's paper "Military Retirees' Post-Service Earnings and Employment", utilized data largely from the 1977 DoD retiree survey and the 1977 Census Public Use Sample. The report concludes that military retirees fare much better in their post-service earnings and employment than had previously been thought. Cooper points out that most previous studies had used a data set with a disproportionate large number of recent retirees, who haven't completed the transition process from military to civilian life.

The study found that retired military officers earn about 25 percent less than comparably aged and educated non-retired veterans, and enlisted retirees earn about 20 percent less than their nonretired peers. However, the earnings differential is accounted for by the fact that military retirees work less than their nonretired counterparts. Military retirees who work full time year round, earn about the same as similiarly employed nonretired veterans.

Military retirees were seen to make decisions that account for lower nominal earnings: 80 percent live in the South or West, near military bases, and many take jobs with pleasant working conditions. When controlling for these factors, retirees fare very well in their post-service careers.

8. Summary

Table 3 is a synopsis of the more recent studies reviewed in this chapter, the variables utilized in those studies are listed in Table 4.

Results from these studies indicate that military service and military vocational training interact with other factors to influence a veterans wage. The extent to which veteran status affects earnings was found to be dependent upon such factors as the state of economy, intelligence, and whether any vocational training was utilized on the job.

A bridging hypothesis has been offered to account for an earnings premium paid to veterans, but it couldn't singularly account for differences in earnings between veterans and non-veterans.

When most human capital investment factors were ignored, one author found that veteran status was an important factor in veterans receiving higher earnings, but still could not account for all differences in earnings between veterans and non-veterans.

In order to better determine if veterans receive a premium to their post-service earnings, the alternative to having served should be examined. By using factors found in human capital investment theory and other important

TABLE 3
A SYNOPSIS OF MORE RECENT STUDIES REVIEWED

AUTHORS, DATE & PURPOSE	METHODOLOGY	RESULTS & CONCLUSIONS
1. Hess 1980 Examined the value of military svc for initial entry into civilian employment.	Compared vets & nonvets initial employment earnings controlling for many factors.	Initial job entry earnings of vets were higher than nonvets, but to a lesser degree during economic slowdowns.
2. Bolin 1980 Examined earnings effects from military and civilian vocational trng.	Longitudinal study using regression analysis controlling for many factors incl voc. trng	Vocational trng, gained from military or civilian source is beneficial to the individual.
3. Fredland & Little 1980 Investigates returns to earnings from in-service voc. trng received by World War II vets.	Compares earnings effects of civilian and military voc. trng of vets & nonvets.	Military and civilian voc trng yields a premium to long-term earnings for those who use it on the job.
4. Fredland & Little 1979 Investigates specific attributes of the bridging hypothesis.	Regression analysis to determine effects of mil svc and descriptive analysis to examine bridging variables.	Bridging hypothesis could not explain differences in earnings of vets & nonvets. Educational differences were important.
5. DeFray 1982 Examines the hypothesis that vet status acts as a screening device for employers.	Regression analysis controlling for age, educatn, residence to determine vet earnings premium.	Vet status was found to act as a valuable screening device. But it couldn't account for the differences alone.
6. Danzon 1980 Examines second career earnings loss of military retirees.	Regression analysis to examine earnings differences of mil retirees and non-career vets.	Military retirees earn 10 to 20 percent less than noncareer veterans.
7. Cooper 1981 Examines military retirees post-service earnings and employment.	Regression analysis to examine earnings differences of mil retirees & non-retired veterans.	Military retirees earn 20% less than non-retired vets but work less. If working full time, they do very well in earnings.

TABLE 4
 VARIABLES USED IN MORE RECENT STUDIES REVIEWED

<u>EXPLANATORY VARIABLES</u>	<u>Hess</u> <u>1980</u>	<u>Bolin</u> <u>1980</u>	<u>Fredland</u> <u>1980</u>	<u>&Little</u> <u>1979</u>	<u>DeTray</u> <u>1982</u>	<u>Danzon</u> <u>1980</u>	<u>Cooper</u> <u>1981</u>
RACE	X	X	X	X	X		X
AGE	X	X		X	X		X
EDUCATION	X	X	X	X	X	X	X
IQ	X	X					
MARRIED	X	X					
RESIDENCE	X	X	X	X	X	X	X
SMSA	X	X		X	X	X	
SES	X						
DUNCAN INDEX			X	X			
ROTTER SCALE	X			X			
VET VS NON-VET	X	X	X	X	X		
MILITARY TRNG		X	X				
CIVILIAN TRNG	X	X	X				
OCCUPATION			X			X	
INDUSTRY						X	
TENURE		X	X				
HOURS WORKED						X	
WEEKS WORKED						X	
UNEMPLOY RATE	X						
LABOR FORCE PART RATE	X						
SCHOOL PART RATE PART TIME	X						
SCHOOL PART RATE FULL TIME	X						
UNION MEMBERSHIP						X	
WORK ETHOS				X			
GEOGRAPHIC MOBILITY				X			
GOVERNMENT WORKER				X			
HEALTH		X		X			
MILITARY BASE						X	X
<hr/>							
<u>EARNINGS MEASURES</u>							
WAGES AND SALARY		X	X	X		X	X
HOURLY EARNINGS	X	X	X		X		
EARNED ANNUAL INCOME			X				

personal and environmental factors, earnings equations can be derived to explain earnings measures for the two groups: veterans and non-veterans.

By placing veterans in the earnings equation for non-veterans, one would be able to estimate their earnings based solely on personal characteristics and environment. The difference between actual earnings and those predicted by the non-veteran earnings model would describe any premium or cost the veteran would receive based almost exclusively on his service in the armed forces. Additionally, the same could be estimated for non-veterans in the veteran's earnings factors model.

II. ANALYSIS METHODOLOGY, DATA BASE AND SAMPLE SELECTION

A. INTRODUCTION

In order to investigate civilian returns to earnings from prior military service, the following hypothesis was tested.

The civilian earnings differential from prior military service is a benefit obtained from the investment in human capital in much the same way as training and job experience are in the civilian sector.

This chapter will detail the methodology used to test the hypothesis, describe the data base, and outline the application of criteria used in obtaining a sample subgroup of the NLS survey cohort for the analysis.

B. DISTRIBUTION OF EARNINGS FACTORS

Several personal and environmental factors available in the data set will be analysed to determine if any statistically significant differences exist in the distribution of earnings factors among veterans and non-veterans. All of the factors analysed are widely recognized as influencing the earnings of individuals.

If the earnings factors for veterans were found to be distributed the same as for non-veterans then any veteran/non-veteran wage differential could be recognized in part as a function of military service. The earnings factors which were determined to be statistically different between

the two groups of the cohort would need to be a part of the multivariate equation used in explaining earnings functions for each group.

There are two main categories of earnings factors used in the human capital earnings models developed in this paper: an individual's personal income earnings factors and those of his environment. A person's income is a reflection of the degree an employer values that individual's contribution to the workplace. Those factors valued by the employer influence the individual's wages. Additionally, environmental factors reflecting labor market conditions also enter the model in determining earnings. Because wages are influenced by the market environment, factors such as the unemployment rate of the community and whether the individual lives in a metropolitan area need to be included in any analysis of earnings.

Candidate earnings factors were grouped into four categories (see Figure 1) following the study by Chamarette (1981): individual traits, family circumstances, personal characteristics, and job environment. These groupings represent an arbitrary decision but serve as a means of organizing many different factors for discussion purposes. The factors used in the analyses are those which were available in the data set. The judgment utilized in the selection of these factors was guided in large part by those factors used in previous human capital earnings equations reviewed in Chapter One.

INDIVIDUAL TRAITS

Age
Intelligence
Health

FAMILY CHARACTERISTICS

Socioeconomic status
Marital status
Number of dependents

JOB ENVIRONMENT

Hours worked per week
Weeks employed per year
Tenure
Number of previous employers
Community unemployment rate
Union membership
Collective bargaining
Region-South or Nonsouth
SMSA

PERSONAL CHARACTERISTICS

Highest school grade attained
Method to learn job at work
 from college education
Method to learn job at work
 from vocational school
Method to learn job at work
 from on-the-job training

Figure 1. Earnings Factors by Category

1. Individual Traits

Age, IQ, health, race and sex are factors that a person is least able to change, and have a direct bearing on earnings. Age limits the amount of experience a person is able to gain thereby limiting his opportunities to reach desired goals or objectives such as entering into contracts, obtaining a job or driving an automobile.

Intelligence has a direct relationship with the ability to learn. Persons better able to learn are better able to influence events in their lives. An example would be the intelligence required to finish high school and move on to higher education/training in order to prepare for a desirable career in the work force.

Health has a direct and indirect impact on the type of work an individual can perform, the ability to satisfactorily perform the job and the duration one is able to perform the job both in the long and short term. All of these have a significant role in determining which jobs a person could perform and the earnings one hopes to realize.

Race and sex were factors treated separately by developing different earnings equations. The importance of race and sex can not be overstated; there are significant differences in earnings for blacks and women. Both race and sex have a relationship with education, training, and job opportunities or at least, the perceived opportunities that society and individuals themselves hold for blacks and women (or any other minority group).

2. Family Characteristics

Parental home environment (or socioeconomic status) and family responsibilities are factors that have been found to be positively correlated with earnings. The socioeconomic status of the parental home reflects the family wealth and experience that the respondent has shared in. The higher the status, the more likely the individual will have been exposed to a positive influence at home, the greater the likelihood that the individual will aspire to the same level of educational and social development.

Marriage and the assumption of responsibilities for dependents tend to positively influence behavior. Married employees are perceived to have a greater sense of responsibility and dependability. Studies by Mobley (1979) confirmed that marital status and having dependents was positively correlated with tenure, the highest turnover ratio was that of employees who were single.

3. Personal Characteristics

Factors concerning education and training are important determinants of earnings. The attainment of educational goals is an indication of a degree of intelligence and maturity. Education enables the individual entry into new and/or different job opportunities much the same as training. Training allows the additional gain of knowledge and skills, making the individual more useful to the employer. Both education and training are investments in human capital resulting in an increased earnings potential.

4. Job Environment

Some factors relating to job environment and experience are community unemployment rate, location of the respondent, union membership, collective bargaining used on the job, number of hours worked in a week, weeks employed during the year, and tenure.

The unemployment rate is a good indication of the availability of job opportunities in the environment. High unemployment in an area might preclude an individual from a

particular employment opportunity and having to settle for something less, and possibly with lower wages.

Since it has been found that lower wages are paid in the south, a variable was established to explain part of the wage differential between the south and the non-south. Differentiating between metropolitan areas and non-metropolitan areas offers the opportunity to examine the effect of living in or near a central city.

Union membership and collective bargaining are considered to be very important factors in the earnings among working men. Understanding the significances of unions and collective bargaining in determining wages could have an impact on whether veterans have given up the advantage of a union and collective bargaining while serving in the military. Additionally, consideration must be given to those higher wages foregone while serving in the armed forces instead of being employed in the civilian sector as a union member.

Naturally, the number of hours worked per week, number of weeks worked during the year, and how long the employee has been with the employer have a direct relationship with earnings.

Two earnings measures are used in the analysis, hourly rate of pay and annual income from wages and salaries.

The following chapter deals with each factor in detail: describing it thoroughly and then offering the results of the descriptive statistical tests and evaluation.

C. DETERMINING THE EFFECTS OF MILITARY SERVICE AS AN EARNINGS FACTOR

Multiple regression analysis performed in Chapter IV will employ those factors examined in Chapter III in order to predict earnings for each of the four groups: white non-vets, white vets, black non-vets, and black vets. The analyses performed in Chapter IV is an application of the logarithmic human capital models of wage determination described by Mincer (1974).

These human capital earnings models can be conceptualized by the equation:

$$\ln(W) = a_0 + \sum a_i (\text{PEF})_i + \sum a_j (\text{EEF})_j$$

where the PEF'S are the personal earnings factors, while the EEF'S are the environmental earnings factors. The advantage of using the logarithmic formula is that as an independent variable changes by one unit, a percentage change equal to that variable's coefficient occurs in the dependent variable. Thus one can easily determine the rate of return from the investment of an additional unit of the independent (explanatory) variable.

In order to use an individual's observation in the data set, data on each earnings factor had to be available. A no response to any earnings factor resulted in the elimination of that individual from the analysis.

To determine the earnings differential for military service and non-military service, two different methods will be employed: the use of a veteran dummy variable and the use of counterfactual earnings equations. The first method employs the use of a dummy variable for veteran status along with other earnings factors in the human capital earnings equation to estimate the earnings of blacks and whites. A positive returns coefficient for veteran status would indicate positive returns to earnings for veterans. Chamarette (1981) employed this methodology in a study of the same NLS cohort using 1976 earnings. Chamarette's results will be compared with those found here.

The second method employed used earnings equations developed for non-veterans to estimate the earnings of veterans with their individual characteristics and circumstances (i.e. earnings factors) and vice versa for each race. Differences between an individual's actual earnings and those derived from the earnings equation will estimate the magnitude of the civilian returns to earnings from military service. Analysis will then be conducted to determine if these premiums or costs are statistically significant for veterans and non-veterans.

A cross-sectional analysis examines the earnings of an individual at one period in time. To determine if there were real life-cycle benefits from military service a longitudinal study would be necessary, so that wages over

time could be examined. This way, one could determine whether benefits from military service diminish or increase with time. This thesis when combined with Chamarette's (1981) study will offer some longitudinal information on lifetime earnings of veterans.

D. DATABASE

Data from the 1980 National Longitudinal Survey of young men, aged 14 to 24 in 1966, were utilized to perform the analysis. The Center for Human Resource Research, Ohio State University, was contracted by the Office of Manpower Policy, Evaluation, and Research, U.S. Department of Labor, for longitudinal studies of the labor-market experience of four groups of the population: Men 45 to 59, Women 30 to 44, and Young Men and Women 14 to 24.

These particular four groups were chosen because each faces different problems in the labor market and all were a concern to policy makers in the government. In particular, young men and women face problems centered around choosing an occupation, including the preparation for the work place and entry into the labor market after completing a formal course of instruction.

The survey originated in 1966 with 5225 non-institutionalized young men, aged 14 to 24, who had been randomly selected by the Bureau of the Census. In order to provide separate reliable statistics for blacks, the sample was

biased to ensure that about 1500 young black men were included. Therefore, all analysis conducted in this paper is differentiated by race.

The original sample did not contain any young men who were serving in the armed forces at the time of the surveys in 1966. Since the age group of the sample, 14 to 24 years, is also the primary age group that the military services draw from, there are sufficient numbers of young men who have experienced military service in the survey in order to perform statistical analysis.

Although initially intended to cover a five year period, 1966 to 1971, the survey was extended for an additional period of five years in 1971 and then again in 1976.

The survey for young men deals with personal and family characteristics as well as labor market participation information. Several thousand pieces of data have been collected for most members of the cohort. This collection of data offers the best longitudinal study base available where an analysis of the differences between veterans and non-veterans could be undertaken.

E. SAMPLE SELECTION

The following criteria were applied to the cohort in order to classify respondents into sets.

LENGTH OF SERVICE CRITERIA: Draft-era, former enlisted veterans who had completed 18 months or more of service in the

military and began that service before the end of the military draft were assigned to Set 1, Veterans. Survey members who had never served in the armed forces were assigned to Set 2, Non-Veterans.

Those members who had entered the military before the advent of the All Volunteer Force (AVF) but served less than 18 months were assigned to Set 3, Short Service Veterans. All veterans who entered the military after December 1972 (when the last conscription took place) were considered AVF Veterans and assigned to Set 4.

The last set to be identified were those individuals who indicated they had completed two nonconsecutive terms of military service. To determine the number of months that an individual had served in the military, four responses in the data set had to be examined. The cohort members were queried in 1966, 1969, 1971 and 1976 as to the number of months they had served in the armed forces since the last survey (except for 1966 which had no time period specified). Therefore each of the four responses was to be exclusive of any earlier survey response to the same question. Any member who answered the question twice or more (during the surveys of 1966, 1969, 1971 and 1976) was assigned to Set 5, Two-Term Veterans.

Since this paper is interested in examining returns to earnings from one term of military service, a judgment had to be made as to how many months a person would have to have

successfully served before he could derive any personal benefit from that service. The use of the 18 month criterion would include those individuals who were originally drafted for 24 months but discharged, as a convenience to the government, a few months early.

The 18 month criterion eliminated unwanted groups from selection as veterans. Military reservists on active duty for training only and those persons who did not complete a tour of military service, whether they were drafted or had voluntarily enlisted would have received only a partial benefit from having served. While other studies have dealt with an examination of the earnings effect of training received in the military, this papers hopes to capture an indication of the effect of the total military experience on an individual's civilian earnings. Thus, persons who had served less than 18 months, Set 3 (Short Service Veterans) will not be utilized in the analysis.

Combining draft-era veterans with AVF veterans would hinder the development of any conclusions that the analysis might offer. The investigation into the civilian earnings effect from military service for the current AVF era is a separate topic and will not be addressed in this paper; therefore, Set 4 AVF Veterans, is eliminated from the analysis.

Set 5, Two Term Veterans, included those individuals who completed a term of service (of any duration), reentered civilian life, and then later completed another term of service (again, of any duration). Also in this set were those former service members who may have incorrectly answered the applicable survey questions; that is, they indicated the same specific period of service on two different surveys. In order to differentiate between one-term veterans and two-term veterans, the 134 members of Set 5 were eliminated from the analysis.

The results of how the original sample of 3409, 1980 survey respondents were categorized are shown in Figure 2.

EMPLOYMENT CRITERION: All cohort members who were not employed full-time were eliminated from the two remaining sets: Set 1 Veterans, and Set 2 Non-Veterans. Those men who responded to the question "Usual hours worked at current or last job, 1980 ?" by indicating 35 hours or more were judged to be employed full time. Those individuals indicating 34 hours or less to the above question were not considered to be full-time employees for purposes of this analysis. Figure 3 shows the effect of having applied both the full-time employment criterion and the draft-era, former enlisted veteran criteria.

Applying the draft-era former enlisted veteran criteria reduced the sample from 3409 (the number of black and white 1980 respondents), to 2296 non-veterans (548 blacks and

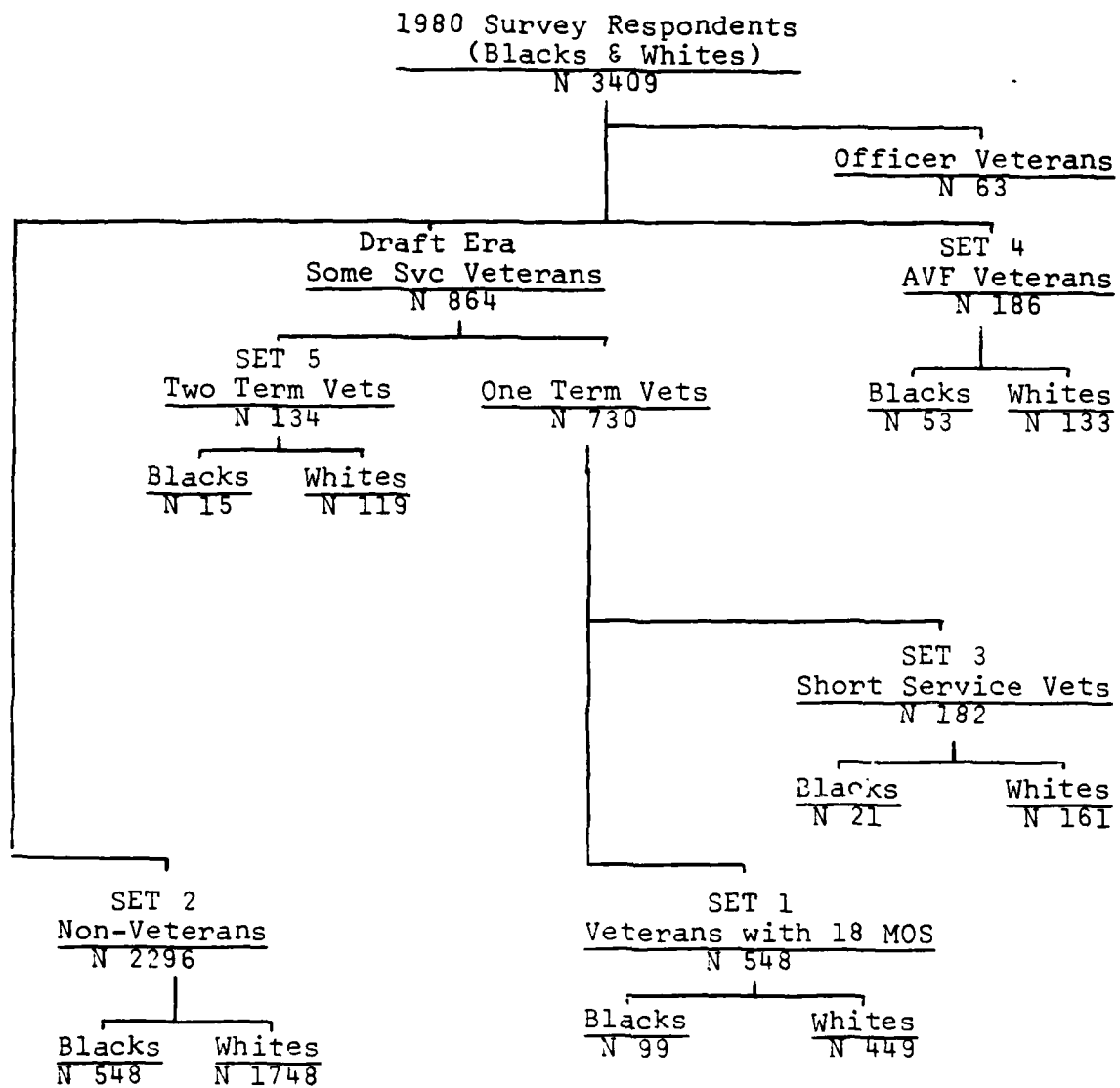

Figure 2. Draft-era Former Enlisted Veteran Criteria Applied

Sample Selected After
Draft Era Former Enlisted Veteran Criteria
Was Applied

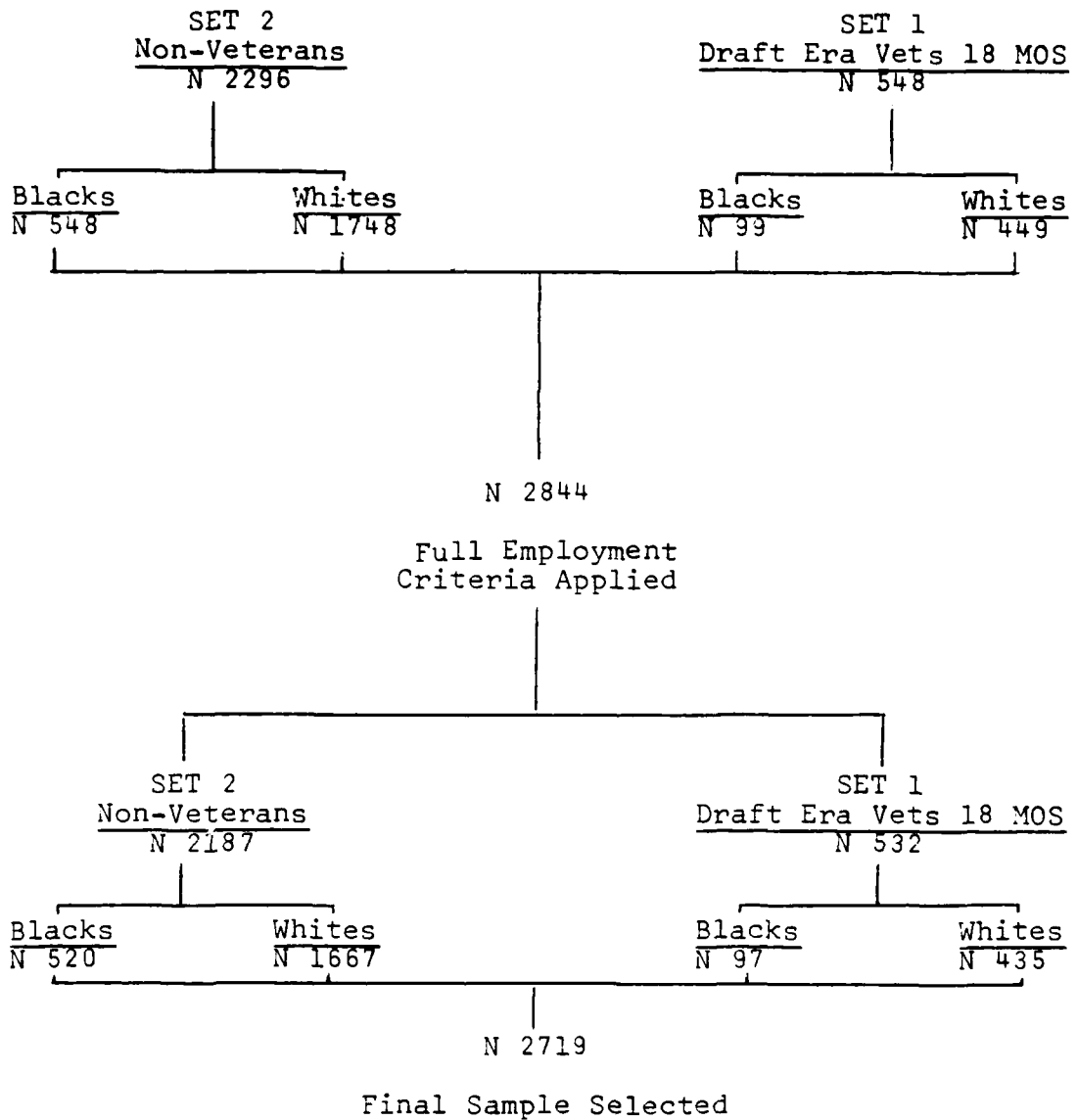

Figure 3. Final Sample: Draft Era Former Enlisted Veteran and Full Employment Criteria Applied

1748 whites) and 548 veterans (99 blacks and 441 whites). By applying the full employment criterion, an additional loss of 116 individuals occur.

The final sample, on which the analysis will be performed, consists of 2719 men: 2187 non-veterans (520 blacks and 1667 whites) and 532 veterans (97 blacks and 435 whites).

F. SUMMARY

This chapter has identified the purposes and methodology of the analyses:

1. The hypothesis to be tested.
2. The approach and methodology used in the analyses.
3. The selection criteria used in obtaining a final sample of veterans and non-veterans.

The chapters that follow will describe further the earnings factors, the analyses performed, and the results of the analyses.

III. EARNINGS AND EARNINGS FACTORS

A. INTRODUCTION

This chapter identifies and explains the measures of earnings and earnings factors used in this thesis. Table 5 is a listing of these factors. Statistical tests to investigate differences between veterans and non-veterans for blacks and whites are presented in Appendices A through S. A summary of these tests and mean values are provided at the end of this chapter, in Table 6.

The factors discussed here were analyzed as either continuous or categorical variables with the use of the Statistical Package for the Social Sciences programs. Three methods were utilized to provide test statistics.

1. Analysis of Variance

SPSS Oneway ANOVA procedures were used to test the statistical significance of differences in the mean values of continuous variables for veterans and non-veterans. The tables shown in Appendices A through S list the following for each factor and dependent variable: the variable name, the mean, standard deviation, the size of the sample group responding, the degrees of freedom (D.F.), the F test value, and the probability (P) that the differences occur by chance.

TABLE 5
CANDIDATE EARNINGS FACTORS

Age	Hours worked per week
Intelligence	Weeks worked during the year
Health	Tenure
Marital status	Number of previous employers
Number of dependents	Union membership
Socioeconomic status	Community unemployment rate
Education	Region
Training	SMSA

2. Chi-square Test

Joint frequency distributions of cases for different pairs of dependent variables and factors are provided in matrix form with the actual numbers and percentages of the groups found in each cell indicated included with this tabulation is a chi-square test to determine whether a systematic relationship exists between the variables observed. The chi-square value (and degrees of freedom) tell only whether or not, variables are statistically independent, it doesn't show how strong the relationship is.

3. Kolmogorov-Smirnov Test

The Kolmogorov-Smirnov two-sample test was conducted for each continuous variable to determine the homogeneity of distribution for the two sample groups. The test is sensitive to any type of difference in the two distributions--median, dispersion, skewness, etc. The Kolmogorov-Smirnov Z and two-tailed probability level are provided.

The Kolmogorov-Smirnov test is better able to describe the strength of similarities of dissimilarities than the chi-square test.

B. EARNINGS MEASURES

1. Hourly Rate of Pay

The question, "Hourly rate of pay at current or last job 1980?" was asked. This question was not responded to by 576 of the 2719 sample members. Responses ranged from .26 to 275.00 dollars an hour.

2. Annual Wages and Salary

Responses to "Income from wages and salary in past year, 1980?" resulted in 2272 non-missing or non-zero responses from sample members. The other sample members responded in the following manner: 321 indicated zero salary and 126 did not answer the question.

C. CANDIDATE EARNINGS FACTORS

Descriptions of the earnings factors used in this thesis are given here. Of the original 5225 sample members in 1966, a total of 1787 were unavailable during the 1980 survey; this left a cohort of 3438. The application of veteran-status and full employment criteria resulted in a final sample of 2719.

Some information concerning the responses of the sample members are offered for nearly every earnings factor used in the analysis. Specific responses to questions on earnings

factors for each sample group (white veterans, white non-veterans, black veterans, and black non-veterans) are offered in Appendices A through S, where crosstabulations by race and veteran status are shown. Information concerning the descriptions and coding information for each factor was obtained from the Ohio State University, NLS of young men 14 to 24 in 1966 Codebook (September, 1982).

1. Age in 1980

Cohort members were asked their age during the first survey, in the fall of 1966. Therefore, fourteen years were added to reflect their age in 1980.

2. Intelligence

Numerous tests were used to determine the general mental aptitude of cohort members in 1966; scores ranged from 50 to 158. However, 858 of the 2719 sample members (over 31 percent) were not tested for mental aptitude.

Because IQ scores were derived from different tests for individuals and rescaled to determine grade point averages, any interpretations made from the use of this factor should be qualified. For this reason as well as the low response rate, IQ was not used as a factor in determining earnings equations for veterans and non-veterans.

3. Health

The question "Does health limit work 1980?" resulted in 190 affirmative responses. 61 sample members did not

respond to the question. A dummy variable of 1 was assigned to those indicating that their health limits work, a value of 0 was assigned to healthy individuals.

4. Marital Status

Sample members were asked to indicate if they were married with their spouse present or if they were in another category. A dummy-variable value of 1 was utilized to record the 2018 married with spouse present and a value of 0 to record the other 701 sample members. The categories for which dummy variables of 0 were constructed were: married with spouse absent, separated, widowed, divorced, and never married.

To capture the effect of marital status this particular measure was chosen. Being married with spouse absent or being separated was judged to be more similar to not being married than to being married. Thus, married with spouse absent and separated were grouped with the non-married categories to form the alternate response to the question of being married with spouse present.

5. Number of Dependents

The response to the question, "Number of dependents excluding wife, 1980?" offers an additional measure of a sample member's responsibilities. Responses ranged from 0 to 9, with 10 no responses.

6. Socioeconomic Status

This variable was created by the NLS Center by combining responses to five items from the 1966 survey concerning the parental home. These five items were: (1) father's occupation (2) father's highest school grade attained (3) mother's highest school grade attained (4) education of oldest, older sibling (5) availability of reading material in the home.

The socioeconomic factor was constructed to have a grand mean of 10.0 and a standard deviation of 3.0. The index ranged from a low of 2.1 to a high of 15.8. There were 153 sample members who didn't have measures of socioeconomic status determined for them. At least three questions had to be responded to in order to have a measure determined.

As one might have guessed, socioeconomic status was found to be highly correlated with education, with r 's ranging from .40 to .57. Therefore, socioeconomic status was not utilized in determining earnings factor equations for veterans and non-veterans, blacks or whites.

7. Education

The highest school grade attained was determined by examining responses to the 1976, 1978, and 1980 surveys concerning education. The 1976 question asked for the highest level of education by school grade attained to date.

The 1978 and 1980 questions dealt with any increases in levels of education achieved since 1976.

8. Training

Three questions were chosen to investigate how training affects earnings. Members were asked to respond to the following questions "Training method to learn work at current or last job 1980 from: vocational school?, college?, on-the-job training?". Their responses are shown below.

- a. vocational school.
 - yes (189)
 - no (2471)
 - no response (59)
- b. college.
 - yes (578)
 - no (1918)
 - no response (223)
- c. on-the-job training.
 - yes (1585)
 - no (1075)
 - no response (59)

Part b (method to learn work at current or last job-- college) was found to be highly correlated with education, with r's ranging from .49 to .73 and was removed from any further analysis. Those indicating yes to the above questions were assigned a dummy- variable value of 1, those indicating no received a value of 0.

9. Hours Worked Per Week

The question asked members to indicate how many hours they usually work at their current or last job 1980. Full employment criterion of 35 hours or more a week was placed on the sample. The full employment requirement, as determined by the number of hours usually worked, reduced the useable sample of veterans and non-veterans from 2844 to 2719. This removed the unemployed or underemployed worker from the sample.

10. Weeks Employed During the Year

Members were asked "Number of weeks worked in past year, 1980?", there were 7 no responses.

11. Tenure

Tenure was computed by using the questions concerning the month and year sample members started working at their current or last job, 1980. These dates (month and year only) were subtracted from when they completed the 1980 survey. Surveys were completed by sample members in the months of October, November and December.

12. Number of Previous Employers

Members were asked for the number of different employers they had worked for since 1966. Responses ranged from 0 (those self-employed) to 10. There were 197 no responses to the question.

This factor was eliminated as an independent variable in determining earnings equations for blacks. Due to the small available sample size the black veterans,

every factor was examined to determine the number of individuals who would be lost if regression analysis was conducted using that factor. In this case, nine black veterans would have been eliminated from the regression analysis if the number of previous employers factor had been retained in the regression analysis. Nine black veterans account for 11 percent of the sample used in the regression analyses. Eliminating a factor for one group within a race necessitates that factor being eliminated for the other groups in the same race.

13. Union Membership

Responses to "Is respondent a member of a union or employee association on current or last job 1980", would have been used as an earnings factor if there had been a clear indication of the results from the question. There were 682 affirmative responses, 120 negative responses, and 1917 sample members did not respond.

Instead of assuming that a no response to the question (from someone who participated in the 1980 survey) was a negative response, the use of union membership as an earnings factor was eliminated from the analysis.

14. Collective Bargaining

The question "Are wages on current or last job set by collective bargaining - union?" resulted in a much better response rate than union membership. There were 800 affirmative responses, and 413 no responses.

Those indicating yes were assigned a dummy-variable value of 1, those indicating no received a 0.

15. Community Unemployment Rate

The 1980 unemployment rate for the labor market of the residences for sample members was determined by the Current Population Survey (CPS) and assigned to each member except for 466 who did not live in an area sampled by the CPS.

Due to the fairly high number of no responses, this factor was eliminated from the regression analysis used to determine earnings equations for blacks. To have retained this factor would have significantly reduced the number of blacks available for the analysis.

16. Region

"Region of residence in 1980" provided these results:

South (1139)

Non-South (1580)

A dummy-variable value of 1 was assigned to Southern residents and a value of 0 was assigned to non-Southern residents.

17. SMSA

"Standard Metropolitan Statistical Area in 1980" had categorized cohort members as follows:

SMSA (1846)

Non-SMSA (873)

Those residing in a central city or the balance of a SMSA were considered to be SMSA residents and assigned a dummy variable value of 1; those Non-SMSA residents were assigned a value of 0.

D. SUMMARY

This chapter has identified and discussed the following:

1. The procedures and statistical tests conducted for each earnings factor utilized in the analysis, the results of which are shown in Appendices A through S and summarized in Table 6, following this summary.

2. Each earnings factor was identified and reviewed for its qualification for use in this thesis.

3. As a result of the review, the following factors were eliminated from consideration for continued use in the analysis.

a. The following were eliminated for black and white veterans and non-veterans:

Intelligence (IQ),
Method to learn work at job from college,
Union membership,
Socioeconomic status.

b. The following were eliminated for black veterans and black non-veterans only:

Number of previous employers,
Community unemployment rate.

TABLE 6
SUMMARY OF EARNINGS AND EARNINGS FACTORS TEST RESULTS
WHITES

FACTOR	FACTOR DESCRIPTION	MEAN VALUES	
		NON-VETERAN	VETERAN
HRPAY	Hourly rate of pay	\$9.31	\$8.85
SALARY	Annual income	\$16995	\$16853
AGE	Age in 1980	32.11	32.97 ***
IQ	IQ score	106.03 ***	101.42
HEALTH	Healthy	94%	92%
MARITAL STATUS	Married, spouse present	77%	81% *
NRDEPTS	Number of dependents excluding wife	1.59	1.61
SES	Socioeconomic status	10.72 *	10.53
HYGRADE	Highest grade attained	13.83 ***	13.35
COLLEGE	Method to learn work college		
		yes	29% ***
	no(0)		19%
VOCOSH	Method to learn work from vocational school		
		yes	7%
			10% **
OJT	Method to learn work OJT		
		yes	58%
			62%
HRSWORK	Hours worked per week	46.61	46.31
TENURE	# of YRs with employer	5.36	5.30
NREMPLOY	# of employers since 1966	2.98	2.99
WKSEMPLD	Weeks employed during year	48.09	48.91
UNION	Union member	yes	85%
			87%
COLLBARG	Wages set by collective bargaining		
		yes	32%
			37%
UNEMRATE	Community unemployment rate	7.26	7.18
REGION	South	34%	29%
SMSA	Central city suburbs (1)	68%	73%

*** significant at .01 level-favoring higher earnings.

** significant at .05 level-favoring higher earnings.

* significant at .10 level-favoring higher earnings.

TABLE 6 (cont.)
BLACKS

FACTOR	FACTOR DESCRIPTION	MEAN VALUES	
		NON-VETERAN	VETERAN
HRPAY	Hourly rate of pay	\$7.06	\$7.28
SALARY	Annual income	\$11333	\$14395 ***
AGE	Age in 1980	32.09	32.31
IQ	IQ score	86.65	89.95
HEALTH	Healthy	91%	94%
MARITAL STATUS	Married, spouse present	60%	66%
NRDEPTS	Number of dependents excluding wife	2.02	1.89
SES	Socioeconomic status	8.073	8.282
HYGRADE	Highest grade attained	11.64	12.81 ***
COLLEGE	Method to learn work college	10%	9%
VOCOSH	Method to learn work from vocational school yes	4%	12% ***
OJT	Method to learn work OJT yes	61%	70%
HRSWORK	Hours worked per week	43.63 *	42.2
TENURE	# of YRs with employer	5.36	5.66
NREMPLOY	# of employers since 1966	3.42	3.17
WKSEMPLD	Weeks employed during year	44.47	45.21
UNION	Union member yes	83%	86%
COLLBARG	Wages set by collective bargaining yes	37%	54% ***
UNEMRATE	Community unemploy rate	7.13	7.19
REGION	South	75%	66%
SMSA	Central city, suburbs	63%	75% **

*** significant at .01 level-favoring higher earnings.

** significant at .05 level-favoring higher earnings.

* significant at .10 level-favoring higher earnings.

IV. EARNINGS EQUATIONS

To ensure that this thesis was examining the earnings of full-time employees, additional sample selection criteria needed to be applied. Chapter II detailed the initial full-employment criterion; in order for veterans and non-veterans to be included in the sample, they had to indicate that they usually worked 35 hours or more each week. However, some sample members indicated very low salaries while claiming to work 35 hours or more each week. The decision was made to eliminate any sample member who indicated a salary of less than \$2800. This number was arrived at by projecting an hourly wage of \$2.00 for a 35 hour work week for 40 weeks. This \$2.00 figure is below the 1980 minimum wage. The intent of this criterion was not to eliminate lowly paid full-time employees but only those employees who could not possibly be employed full-time.

Additionally, sample members indicating usually working more than 80 hours a week were eliminated from any further analyses. It was felt that individuals working more than 80 hours a week were more than full-time employees.

A. REGRESSION ANALYSIS WITH VETERAN STATUS

1. Introduction

Chamarette (1981) tested the hypothesis that civilian earnings received by those who had completed a tour of

military duty were different from those earnings of individuals who did not undertake military service. Chamarette used multiple regression to produce explanatory earnings equations for two groups, blacks and whites. The earnings equations included a dummy variable for veteran status. Chamarette estimated earnings equations using 1976 income values for the same cohort studied in this thesis.

In order to provide a comparison of Chamarette's work with results from this thesis, earnings equations for blacks and whites using a dummy variable methodology for veteran status have been constructed and will be described in this section. Additionally, estimates of earnings premiums for veterans using counterfactual earnings estimates are undertaken in the following two sections in this chapter. Results of the models will be compared with Chamarette's results in the section summary.

2. The Models

One regression model for each group, blacks and whites was constructed to test the hypothesis that military service is an effective method of investing in human capital. Each model used similar earnings factors, but different dependent variables were employed. Chamarette used two models with different dependent variables to predict earnings for each group: hourly rate of pay and total income from wages and salary. However, the earnings equations utilizing total income from wages and salary as the dependent

variable consistently showed higher R² values than hourly rate of pay. The same held true for the investigations by this author: therefore, salary will be the only dependent variable reported in this thesis.

The earnings equation models are similar to Mincer's (1974) human capital estimating equation and can be formally expressed as:

$$W = a_0 + a_j V + \sum a_i EF_i$$

where W is the dependent variable, a_0 is constant, V is the dummy variable assuming the value zero for non-veterans and one for veterans, and $\sum EF$ is the sum of all the other earnings factors.

Table 7 lists the variables used in the earnings equations. Some earnings factors discussed in Chapter III were not used in the regression analysis. Besides those already listed in the previous chapter's summary the following factors were not used in the earnings equations: health, number of dependents, region, unemployment rate for whites as well as blacks, method to learn work at job from vocational school, and collective bargaining for whites. The inclusion of these factors in the earnings equations would not have significantly improved the model's R² value.

TABLE 7
REGRESSION MODEL VARIABLES
FOR BLACKS AND WHITES

<u>VARIABLES</u>	<u>DESCRIPTION</u>	<u>BLACKS</u>	<u>WHITES</u>
<u>DEPENDENT</u>			
LNSALARY	Natural logarithm of Annual Income	X	
SALARY	Annual Income		X
<u>INDEPENDENT</u>			
AGE 80	Age in 1980	X	X
HYGRADE	Highest grade attained, 1980	X	X
MARSTA	Married, with spouse present No=0, Yes=1	X	X
VET	Non-Veteran=0, Veteran=1	X	X
SMSA	Non-SMSA=0, SMSA=1	X	X
MLWOJT	Method to learn work at job From OJT: No=0, Yes=1	X	X
HRSWORK	Hours usually worked per week	X	X
WKSEMPLD	Weeks employed 1979-1980	X	X
TENURE	Years with current employer	X	X
NREMPLOY	Number of employers 1966-1980		X
COLLBARG	Collective bargaining used to determine wages: No=0, Yes=1	X	

Pearson Correlation coefficients for the earnings factors are shown in Table 8 for blacks and Table 9 for whites. Only one earnings factor intercorrelation exceeded .40: number of employers is highly negatively correlated with tenure for whites (number of employers was not used for blacks).

TABLE 8
CORRELATION COEFFICIENTS OF EARNINGS FACTORS FOR BLACKS WITH SALARY AND LNSALARY

	TENURE	HRSWRK	SMSA	MLWOTT	AGE80	COLBARG	WKSEMPLD	HYGRADE	VET	MARRIED	LNSALARY	SALARY
TENURE												
HRSWRK	-.07											
SMSA	-.00	-.02										
MLWOTT	.10	-.08	.01									
AGE80	.20	.07	-.01	.07								
COLBARG	.23	-.13	.11	.00	.03							
WKSEMPLD	.16	.01	.02	-.02	.00	-.02						
HYGRADE	-.12	.07	.31	-.05	-.02	-.08	.07					
VET	-.07	.10	.15	.04	.12	.02	-.13	.27				
MARRIED	.11	.05	-.05	.02	.10	.06	.09	.04	.13			
LNSALARY	.13	.11	.19	.04	.03	.10	.57	.24	.11	.19		
SALARY	.17	.16	.31	.02	.16	.10	.32	.42	.30	.18	.64	1.00

TABLE 9
CORRELATION COEFFICIENTS OF EARNINGS FACTORS FOR WHITES WITH SALARY AND LNSALARY

		TENURE HRSWRK SMSA MLWOTT AGE80 COLBARG WKSEMP LD HYGRADE VET MAR LNSLRY SLRY									
TENURE											
HRSWRK	-.09										
SMSA	-.01	-.10									
MLWOTT	.09	-.06	-.02								
AGE80	.34	.06	-.05	.01							
NREMPLOY	-.50	-1.1	.04	-.03	-.21						
WKSEMP LD	.11	.02	.03	-.01	.03	-.08					
HYGRADE	-.11	.07	.12	-.10	-.03	-.04	.08				
VET	-.03	.05	.02	.02	.11	-.08	-.12	-.14			
MARRIED	.05	.06	-.09	-.01	.11	-.07	.05	-.05	.01		
LNSALARY	.07	-.20	.14	.06	.04	.21	.10	.13	-.26	-.01	
SALARY	.19	.06	.21	.04	.22	-.05	.21	.31	-.18	.10	.57

3. Results of the Models

Table 10 details the results of the multiple regression analysis performed to establish an earnings equation for blacks, while Table 11 lists the earnings equation for whites. Generally, it was found that:

a. Equations for both whites and blacks were significant at the .001 level.

b. For blacks, every factor except method to learn work at job from OJT, age, and tenure was found to be statistically significant at the .01 level.

c. Except for veteran status and age, each earnings factor yielded positive returns to earnings for blacks and whites, with nearly the same degree of advantage for both races. Marital status and SMSA give highly positive returns to earnings.

(1) Blacks. The model for blacks explained 44 percent of the variance in the logarithm of annual income from wages and salary, $R^2 = .44$. Three factors had coefficients that were not significant at the .01 level--age, tenure, and method to learn work at job from OJT. The most influential factors were SMSA and marital status with rates of return of 22.5 percent each, collective bargaining with a rate of return at 20 percent and veteran status with a rate of return of 19 percent.

TABLE 10

EARNINGS EQUATION FOR BLACKS

Dependent variable, LNSALARY: $\bar{X} = 9.524 = \$16192.01$

Std. dev. = 7738.83

<u>EARNINGS FACTORS</u>	<u>B</u>	<u>T</u>	<u>SIGNIFICANCE OF T</u>
WKSEMPLD	.07228	19.694	.000
HYGRADE	.05006	4.549	.000
SMSA	.22559	3.822	.000
MARSTA	.22550	3.786	.000
COLLBARG	.20153	3.676	.000
HRSWORK	.01361	3.654	.000
VET	.19352	3.467	.000
MLWOJT	.10420	1.924	.055
TENURE	.00621	1.027	.305
AGE80	-.00195	-.224	.823
(CONSTANT)	4.15253		

$R^2 = .44$ d.f.(10,733) $F = 57.14$, significance = .000
 N = 744

TABLE 11
EARNINGS EQUATION FOR WHITES

Dependent variable, SALARY: \bar{X} = 20030.65
Std. dev. = 9567.29

<u>EARNINGS FACTORS</u>	<u>B</u>	<u>T</u>	<u>SIGNIFICANCE OF T</u>
HYGRADE	1119.23	13.218	.000
SMSA	4206.31	9.119	.000
AGE80	555.90	7.881	.000
TENURE	395.09	7.357	.000
WKSEMPLD	353.92	6.517	.000
MARSTA	2308.39	4.369	.000
NREMPLOY	520.10	4.161	.000
HRSWORK	92.01	3.721	.000
MLWOJT	1337.74	3.115	.002
VET	-2882.22	-6.132	.000
(CONSTANT)	-44544.29		

R^2 = .28 d.f.(10,1573) F = 60.47 significance = .000
N = 1584

A 19 percent rate of return for veteran status equates to a \$3,133 premium for the average black veteran. The only earnings factor with a negative coefficient was age, but it was not statistically significant.

(2) Whites. The model for whites had an R^2 equal to .28. Although the equation explains less than a third of the variance in annual income from wages and salary, the equation yielded predictions significant at the .001 level, and all earnings factors are significant at the .01 level. The factors proving most influential in determining income were SMSA with \$4206, marital status with \$2308, and over one thousand dollars for both method to learn job at work from OJT and highest school grade attained.

The only earnings factor having a negative influence was veteran status: veterans on the average earned \$2882 less than non-veterans.

4. Summary

This section used the methodology that Chamarette (1981) used to test the hypothesis of an earnings premium to veteran status. Chamarette concluded from his analyses that veteran status was not significantly related to future civilian earnings for both whites and blacks. This conclusion differs from the results obtained from the analyses performed here; veteran status was observed here to be detrimental to earnings for whites, while black veterans were

observed here to enjoy a significant earnings advantage--an average of \$3133.

Although veteran status was not found to be statistically significant in any of Chamarette's regression equations, it was observed to be significant at the .01 level in this study for both groups. Chamarette used a single full-employment selection criterion--35 hours or more usually worked each week, thus he was sure to have included some sample members who had unrealistically low salaries to be included as full-time employees.

Results between this study and Chamarette's are significantly different for blacks. Although the same data base was utilized, Chamarette (1981) used the 1976 civilian earnings of sample members as the dependent variable. For veterans, this four year period may have been important to their earnings realizations. An additional four years meant that they were more firmly established in the civilian labor force and were now starting to enjoy significant returns to their veteran status.

DeTray (1982) examined the proposition that employers use veteran status as a screening device for employee selection. Although he concluded that the use of veteran status couldn't account for all of the earnings differences between veterans and non-veterans, it could account for some of the differences. Veterans are given a slight preference over non-veterans when competing for

federal employment as well as in some state and local governments. Affirmative action programs and increasing adherence to equal opportunity regulations have opened employment opportunities for minority members. Black veterans would benefit from this as well as others, but perhaps even more so since some employers might use veteran status as a screening device while seeking minority employees.

Differences in results from the 1976 and 1980 data are also a reflection of differences in levels of national economic activity. There was a recession in 1975-1976 resulting in high rates of unemployment experienced throughout the United States, particularly in the black community. Levels of economic activity in 1980 were much improved over that of the 1975-1976 period.

The results from the analyses performed in this section would lead one to conclude that for whites the military as a method of investing in human capital was detrimental, while the opposite could be said for blacks. The next two sections in this chapter use counterfactual earnings equations to conduct a more detailed examination into whether military service has been a good investment for those who have served and a missed investment opportunity from which non-veterans could have benefited.

B. EARNINGS EQUATIONS FOR WHITE VETERANS AND NON-VETERANS

1. Introduction

Earnings equations for each race were determined by using multiple regression analysis to estimate separate earnings equations for veterans and non-veterans. As previously pointed out at the beginning of this chapter, additional criteria were applied to ensure that only those sample members who were employed full-time were used in the analysis.

This section details the analysis and its results when earnings equations developed for non-veterans are used to estimate the counterfactual earnings of veterans, and vice versa. An estimate of the benefit or cost from not having been a veteran can be obtained by subtracting the individual's actual earnings from his predicted earnings.

2. The Models

Table 12 lists the variables used in the earnings equations for whites (as well as blacks). The same earnings factors were used to construct earnings equations for veterans and non-veterans. The inclusion of other earnings factors not used in the earnings equations resulted in no significant improvement in the model's R^2 . Pearson correlation coefficients for the earnings factors are shown in Table 13 for both white non-veterans and white veterans.

TABLE 12
REGRESSION MODEL VARIABLES FOR BLACKS AND WHITES-
(VETERANS AND NON-VETERANS)

<u>VARIABLES</u>	<u>DESCRIPTION</u>	<u>BLACKS</u>	<u>WHITES</u>
LNSALARY	Natural logarithm of annual income	X	
SALARY	Annual income		X
<u>INDEPENDENT</u>			
Age 80	Age in 1980	X	X
Hygrade	Highest grade attained, 1980	X	X
MARSTA	Married with spouse present no = 0 yes = 1	X	X
SMSA	Non-SMSA=0, SMSA=1	X	X
MLWOJT	Method to learn job at work from OJT: no=0, yes= 1	X	X
HRSWORK	Hours usually worked per week	X	X
WKSEMPLD	Week employed 1979-1980	X	X
TENURE	Years with current employer	X	X
NREMPLOY	Number of employers 1966-1980		X
COLLBARG	Collective bargaining used to determine wages: no=0, yes=1	X	

Only one earnings factor had a correlation coefficient that exceeded .37 with another earnings factor: number of previous employers had a -.57 correlation with tenure for veterans and -.51 for non-veterans. Salary was used as the dependent variable.

3. Results of the Analyses

Tables 14 and 15 detail the results of the multiple regression analysis performed to establish earnings

TABLE 13

CORRELATION COEFFICIENTS OF EARNINGS FACTORS FOR WHITE NON-VETERANS/VETERANS WITH SALARY AND LN SALARY

	CORRELATION COEFFICIENTS OF EARNINGS FACTORS FOR WHITE NON-VETERANS/VETERANS WITH SALARY AND LN SALARY													
	NON-VETERANS	VETERANS	HRSWRK	COLLBARG	WKSEMPLD	AGE80	MARSTA	SMSA	MLWOJT	TENURE	HYGRADE	LNSALARY	SALARY	LN SALARY
HRSWRK		.02												
NREMPLOY	-.07													
WKSEMPLD	.04	-.10												
AGE80	.05	-.25	.08											
MARSTA	.05	-.06	.11	.13										
SMSA	-.07	.03	.01	-.07	-.09									
MLWOJT	-.06	-.02	.04	.02	-.02	-.01								
TENURE	-.12	-.51	.11	.37	.04	-.01	.09							
HYGRADE	.14	-.07	.05	-.04	-.04	.11	-.11							
LNSALARY	.13	-.12	.26	.24	.16	.22	.08	.29						
SALARY	.18	-.15	.21	.27	.14	.20	.05	.31	.20	.20	.31	.94		

TABLE 14

EARNINGS EQUATION FOR WHITE VETERANS

Dependent variable, SALARY: $\bar{X} = \$19968.04$

Std. dev. = 7903.04

<u>EARNINGS FACTORS</u>	<u>B</u>	<u>T</u>	<u>SIGNIFICANT OF T</u>
HYGRADE	1185.08	5.810	.000
TENURE	365.52	3.245	.001
AGE80	412.68	2.906	.004
SMSA	2543.00	2.738	.007
HRSWORK	133.81	2.736	.007
WKSEMP LD	474.71	2.705	.007
MARSTA	430.75	0.427	.670
NREMPLOY	-158.36	-0.602	.548
MLWOJT	-126.24	-0.153	.878
(CONSTANT)	-43717.22		

$R^2 = .25$ d.f. = (9,310) $F = 11.58$ significance = .000

$N = 320$

TABLE 15

EARNINGS EQUATION FOR WHITE NON-VETERANS

Dependent variable, SALARY: \bar{X} = \$21106.92

Standard Deviation = 9505.23

<u>EARNINGS FACTORS</u>	<u>B</u>	<u>T</u>	<u>SIGNIFICANCE OF T</u>
HYGRADE	1075.36	11.634	.000
SMSA	4322.05	8.161	.000
AGE80	620.59	7.704	.000
HRSWORK	192.41	5.936	.000
WKSEMPLD	561.63	5.582	.000
TENURE	333.85	5.480	.000
MARSTA	2808.34	4.574	.000
MLWOJT	1365.70	2.749	.006
NREMPLOY	209.67	1.447	.148
(CONSTANT)	-60260.44		

$R^2 = .30$ d.f. = (9,1124) F = 53.11 significance = .000
 N = 1134

equations for white veterans and non-veterans, respectively.

In general, the results were as follows:

1. Both equations were significant at the .001 level.
2. All earnings factors for white veterans were significant at the .01 level except for marital status, method to learn work at job from OJT, and number of previous employers, while for non-veterans, the only earnings factor not significant at the .01 level was number of previous employers.
3. There was a statistically significant difference in the average actual salaries of veterans and non-veterans at the .01 level.

a. Veterans

The model for veterans explained 25 percent of the variance in annual income from wages and salary. Number of previous employers and method to learn work at job from OJT had negative coefficients. Factors proving influential to earnings were highest grade attained, tenure and SMSA.

b. Non-Veterans

The model for non-veterans explained 30 percent of the variance in annual income from wages and salary. No earnings factor had a negative coefficient, and the only factor not significant at the .01 level was number of previous employers. Highest school grade attained and SMSA were again observed to be important influences to earnings for non-veterans as well as veterans.

c. Summary for White Earnings Equations

The models showed that the significance of particular factors depended on veteran status. On the average, the non-veteran who was married with spouse present, living in a SMSA, and learned his job at work from OJT enjoyed a \$5600 advantage over veterans who claimed the same characteristics. The greater the number of previous employers, the more advantage to earnings for the non-veteran, while the reverse was true for veterans. Age, on the average, was a more influential factor for non-veterans than veterans; the difference in age coefficients was over two hundred dollars and was statistically significant.

4. Predicting Earnings

Earnings for veterans were predicted with the earnings equation for non-veterans (shown in Table 15), while earnings for non-veterans were predicted with the earnings equation for veterans (shown in Table 14). Subtracting the predicted salary from the individual's actual salary would show if an individual could have earned higher or lower levels of income if that individual, with all of his own unique characteristics and circumstances, had been a member of the other veteran status group.

Table 16 lists the mean and standard deviation for salary, predicted salary (using the equations for the other group), and the difference for veterans and non-veterans. On the average, veterans were predicted to earn \$971 more

TABLE 16

EARNINGS PREDICTION RESULTS FOR WHITE VETERANS
AND NON-VETERANS

	MEAN	STD DEV
1. WHITE VETERANS, N = 320		
a. SALARY	19968	7903
b. PREDICTED SALARY FROM NON-VETERANS EARNINGS EQUATION	20886	5226
c. SALARY DIFFERENCE	-971	7311
2. WHITE NON-VETERANS, N = 1134		
a. SALARY	21107	9505
b. PREDICTED SALARY FROM VETERANS EARNINGS EQUATION	19641	5782
c. SALARY DIFFERENCE	1428	8777

if they had been non-veterans; veteran status resulted in a loss for veterans. The difference for the average non-veteran showed a \$1428 premium from not having been a veteran.

To determine if these results were statistically significant, two-tailed statistical tests were conducted. Since the existence of any difference whatsoever between the individual's actual salary and his predicted salary is of interest, the null hypothesis was tested.

For veterans, the 98% confidence interval for zero mean difference was computed to be:

$$0 \pm (2.326) \frac{7311}{\sqrt{320}} = 0 \pm \$951$$

Since -971 (from Table 16) lies outside the 98 percent confidence interval and the two-sided prob value is .0174, it can be said that the earnings difference is significant at the .02 level. White veterans on the average, suffered an average earnings disadvantage of \$971 for having served in the military. Thus, military service was not another form of investment in human capital that proved effective for whites.

For non-veterans, the 98% confidence interval was computed:

$$0 \pm (2.326) \frac{8777}{\sqrt{1134}} = 0 \pm \$606$$

The null hypothesis was rejected for non-veterans since the earnings difference of \$1428 lies outside the confidence interval of \$606, with a two-sided prob-value of .000; therefore, the earnings difference is significant at the .02 level. White non-veterans on the average, were better off for not having served based on their personal characteristics and on qualities that determine earnings.

AD-A132 781 CIVILIAN RETURNS TO EARNINGS FROM PRIOR MILITARY
SERVICE(U) NAVAL POSTGRADUATE SCHOOL MONTEREY CA
O P REAMS JUN 83

2/2.

UNCLASSIFIED

F/G 5/9

NL

END
DATE
FILMED
NO. 104
DTIC

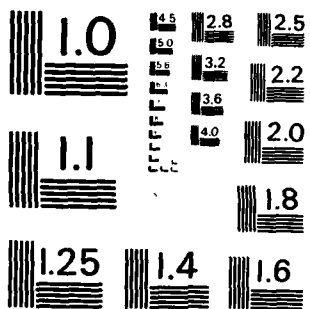

MICROCOPY RESOLUTION TEST CHART
NATIONAL BUREAU OF STANDARDS - 1963 - A

C. EARNINGS EQUATIONS FOR BLACK VETERANS AND NON-VETERANS

1. Introduction

The same method of analysis applied to white veterans and non-veterans in the previous section was applied to black veterans and non-veterans. The results are described in this section.

2. The Models

Table 12 listed the variables used in the earnings equations for blacks (as well as whites). The inclusion of other earnings factors discussed in Chapter III would not have significantly improved the model's R^2 . Pearson correlation coefficients for the earnings factors are shown in Table 17 for both non-veterans and veterans. For blacks, only one earnings factor had a correlation coefficient that exceeded .40 with another earnings factor; age had a .41 correlation with tenure for veterans. The natural logarithm of salary was used as the dependent variable.

3. Results of the Analyses

Tables 18 and 19 detail the results of the multiple regression analysis performed to establish an earnings equation for black veterans and non-veterans, respectively. In general, the results were as follows:

1. Both equations were significant at the .001 level.
2. All earnings factors for black non-veterans were significant at the .05 level, while all but hours worked per week were significant at the .05 level for veterans.

TABLE 17

CORRELATIONS COEFFICIENTS OF EARNINGS FACTORS FOR BLACK NON-VETERANS/VETERANS WITH SALARY AND LNSALARY

NON-VETERANS		VETERANS														
		HRSWRK	COLLBARG	WKSEMPLD	AGE80	MARSTA	SMSA	MLWOJT	TENURE	HYGRADE	LNSALARY	SALARY	TENURE	HYGRADE	LNSLRY	SLRY
HRSWRK	-0.12	-0.01	-0.01	0.21	0.09	-0.17	0.00	0.11	0.27	0.28						
COLLBARG	-0.09	-0.27	0.11	-0.15	-0.15	0.08	0.18	-0.17	0.02	-0.02						
WKSEMPLD	-0.01	-0.02	0.08	0.07	-0.00	-0.04	0.02	0.01	0.21	0.20						
AGE80	0.14	0.02	-0.03	-0.00	0.02	0.07	0.41	0.19	-0.13	-0.14						
MARSTA	0.08	0.10	0.11	0.11	-0.04	0.01	0.15	0.05	0.40	0.37						
SMSA	-0.04	0.25	0.08	-0.05	-0.06	-0.13	0.03	0.09	0.24	0.27						
MLWOJT	-0.07	0.03	0.08	-0.12	0.02	0.05	0.18	-0.19	-0.04	-0.06						
TENURE	-0.11	0.26	0.16	0.16	0.17	-0.00	0.07	0.04	0.21	0.16						
HYGRADE	0.11	0.07	0.14	-0.20	0.05	0.37	-0.04	-0.12	0.20	0.23						
LNSALARY	0.13	0.28	0.26	0.04	0.21	0.41	0.13	0.15	0.50	0.98						
SALARY	0.15	0.21	0.22	0.07	0.18	0.38	0.06	0.12	0.49	0.94						

TABLE 18

EARNINGS EQUATIONS FOR BLACK VETERANS

Dependent variable, LNSALARY: $\bar{X} = 9.634 = \$16359.89$
 standard deviation = 5988.73

<u>EARNINGS FACTORS</u>	<u>B</u>	<u>T</u>	<u>SIGNIFICANCE OF T</u>
MARSTA	.28350	3.386	.001
AGE80	-.04396	-2.952	.004
SMSA	.22975	2.825	.006
WKSEMP LD	.03801	2.779	.007
HYGRADE	.04727	2.261	.027
COLLBARG	.18039	2.252	.028
TENURE	.02150	2.128	.037
HRSWORK	.01142	1.786	.079
MLWOJT	.02777	0.335	.739
(CONSTANT)	7.41229		

$R^2 = .44$ d.f. (9.62) $F = 5.46$ significance = .000
 N = 72 BLACK VETERANS

TABLE 19

EARNINGS EQUATIONS FOR BLACK NON-VETERANS

Dependent variable, LNSALARY: $\bar{X} = 9.406 = \$13546.74$
 standard deviation = 6710.29

<u>EARNINGS FACTORS</u>	<u>B</u>	<u>T</u>	<u>SIGNIFICANCE OF T</u>
HYGRADE	.06273	8.316	.000
SMSA	.21342	4.739	.000
WKSEMPLD	.02359	3.507	.001
COLLGARG	.15583	3.577	.000
MLWOJT	.12187	2.967	.003
MARSTA	.12460	2.883	.004
HRSWORK	.00831	2.515	.012
AGE80	.01514	2.319	.021
TENURE	.00931	2.065	.040
(CONSTANT)	6.21511		

$R^2 = .45$ d.f. = (9,308) F = 28.11 significance = .000
 N = 318 BLACK NON-VETERANS

3. There was a statistically significant difference in the average actual salaries of veterans (\$16360) and non-veterans (\$13547) at the .01 significance level.

a. Veterans

The model for veterans explained 44 percent of the variance in the natural logarithm of annual income from wages and salary. Age was the only factor that had a negative coefficient. Marital status with a 28 percent rate of return, SMSA with a 23 percent rate of return, and collective bargaining with an 18 percent rate of return showed the largest influence on earnings.

b. Non-Veterans

The model for non-veterans explained 45 percent of the variance in the natural logarithm of annual income from wages and salary. No earnings factor had a negative coefficient and all earnings factors were significant at the .05 level. SMSA with a 21% rate of return, collective bargaining with a 16% rate of return and marital status and method to learn work at job from OJT with 12 percent rates of return were the most influential earnings factors for non-veterans.

c. Summary for Black Earnings Equations

Specific earnings factors were found to be, for the most part, similar in their degree of influence in the earnings of black veterans and non-veterans. However, married with spouse present veterans enjoyed a rate of return difference of 16% over non-veterans who claimed the same characteristic. Age, on the average, for veterans had a negative influence on

their earnings while it offered non-veterans a 1 1/2 percent rate of return.

4. Predicting Earnings

Earnings for veterans were predicted with the earnings equation for non-veterans (shown in Table 19), while earnings for non-veterans were predicted with the earnings equation for veterans (shown in Table 18). Table 20 lists the mean and standard deviation for salary, predicted salary (using the equation for the other group), and differences for veterans and non-veterans.

TABLE 20
EARNINGS PREDICTION RESULTS FOR
BLACK VETERANS AND NON-VETERANS

	<u>MEAN</u>	<u>STD DEV</u>
1. BLACK VETERANS, N=72		
a. SALARY	\$16360	\$5989
b. PREDICTED SALARY FROM NON-VETERANS EARNINGS EQUATION	13819	3815
c. SALARY DIFFERENCE	2437	5590
2. BLACK NON-VETERANS, N=318		
a. SALARY	\$13547	\$6710
b. PREDICTED SALARY FROM VETERANS EARNINGS EQUATION	13442	6388
c. SALARY DIFFERENCE	-102	6902

On the average, veterans enjoy a \$2437 premium for being a veteran, while non-veterans lose an average of \$102 for not having been veterans. To determine if these results were statistically significant, statistical tests using two-sided confidence intervals were conducted.

For black veterans the 98% confidence interval was computed:

$$0 \pm (2.326) \frac{5590}{\sqrt{72}} = 0 \pm \$1532$$

Since \$2437 (taken from Table 20) lies outside the 98% confidence interval and the two-sided prob-value is .000, it can be said that the earnings difference is significant at the .02 level. Black veterans on the average, enjoy a premium for having served that they might not have attained if they had not been veterans.

For non-veterans, the 98% confidence interval was computed:

$$0 \pm (2.326) \frac{6902}{\sqrt{318}} = 0 \pm \$900$$

The salary difference of -\$102 lies within the confidence interval and the two-sided prob-value is .7948, so the null hypothesis must be accepted: there is no significant difference in the actual and predicted earnings of

non-veterans at the .02 level. Therefore, for non-veterans lack of veteran status was insignificant in determining their earnings.

D. SUMMARY

This chapter tested the hypothesis that earnings received by those who had completed a tour of military duty were different from earnings of individuals who chose not to undertake military service. Two methodologies were employed to test the hypothesis. The first methodology used a dummy-variable technique for veteran status to estimate earnings equations.

Using this technique, Charmarette (1981) found that veteran status negatively influenced later civilian earnings of veterans for both blacks and whites. Analysis conducted in this thesis using the same methodology produced a different finding. Veteran status was observed to detract from civilian earnings for whites; but, for blacks, the average veteran enjoyed a significant earnings advantage.

A different technique was used to test the same hypothesis in sections B and C of this chapter. Separate earnings equations were determined for the four subgroups: black veterans and non-veterans, white veterans and non-veterans. Utilizing the earnings equations to predict the earnings of veterans had they been non-veterans (and vice versa) enables the benefit or cost of not having been a member of the other

group to be calculated. Not only does this analysis determine the benefit or cost of veteran status to veterans, it also measures the benefit or cost to non-veterans if they had been veterans.

On the average, white veterans were predicted to earn \$971 more than their actual earnings had they been non-veterans, this difference is significant at the .02 level. At that level of significance, white veteran estimated annual civilian earnings loss from veteran status was \$971.

White non-veterans enjoyed a \$1428 premium on the average for not having served in the armed forces, and this result was determined to be significant at the .02 level. This finding is consistent with the finding that veterans suffered an average earnings disadvantage of \$971. Taking the average between the predicted white veterans loss for not being a non-veteran, \$971, and the premium that white non-veterans enjoy from not having served, \$1428, results in a net \$1200 estimated average civilian earnings disadvantage to white veterans.

Black veterans, on the average, enjoyed a \$2437 premium for having served when compared to the earnings projected if they had been non-veterans, these results were significant at the .02 level. Although black non-veterans were predicted to earn an additional \$102 if they had been veterans this finding was not significant at the .02 level and it contradicts the large premium predicted for black veterans

due to their veteran status. This contradiction is a possible result of the small sample size of black veterans available (black veterans, 72; non-veterans, 318) and the inability of the black veterans earnings equation to explain much of the variance in earnings, as indicated by the low R^2 value.

V. SUMMARY, CONCLUSIONS AND RECOMMENDATIONS

A. SUMMARY

A tour of service in the Armed Forces of the United States was studied in order to determine its value as an investment in human capital. Information gathered during the 1980 National Longitudinal Survey of young men aged 14 to 24 in 1966 was used to conduct the analyses. Criteria for selection called for sample members who were full-time employees and who had either never served in the armed forces or had served one term of service as an enlisted man for a minimum of eighteen months and began that service before the end of the draft-era.

Principles of human capital theory were reviewed as were eight studies previously reviewed by Chamarette (1981). Additionally, seven more recent studies examining the value of military service as an investment were reviewed. Two of these studies, Danzon (1980) and Cooper (1981), dealt with earnings differences between military retirees and non-career veterans. Both concluded that military retirees earn about 20 percent less than non-career veterans, but Cooper points out that when military retirees are employed full-time they earn more than the average non-retired veteran. Fredland and Little (1979) concluded that there was no evidence to support a bridging hypothesis that predicted that veterans

would earn higher salaries as a result of having served in the armed forces. Bolin (1980) and Fredland and Little (1930) examined the earnings effects of vocational training for veterans and non-veterans, both studies concluded that vocational training yields a premium to those who use it whether it was gained from the military or within the civilian community. Hess (1980) found that initial job-entry earnings of veterans were higher than those of non-veterans but to a lesser degree during economic slowdowns.

The review of previous studies indicates that there is no clear consensus of opinion on whether there are distinct benefits to post-service earnings from having served in the armed forces. Results are highly dependent on the sample selected and the methodology used.

Chapter II discusses earnings factors, the hypothesis to be tested, the data base and the sample selection criteria. Chapter III describes the candidate earnings factors considered for selection in the earnings equations.

Two methodologies were employed in Chapter IV to test the hypothesis that military service is a beneficial investment in human capital. The veteran status dummy-variable technique, the first method found negative returns for whites on the average of \$2882, while black veterans enjoyed a significantly large earnings advantage over black non-veterans on the average of \$3133. These conclusions differ in part from the conclusions reached by Chamarette (1981) and Bolin

et al. (1980), who used the same NLS data base but data from 1976 and 1969-1971, respectively. Chamarette and Bolin et al. found that both white and black veterans suffered a post-service earnings disadvantage when compared to non-veterans of their own race. Results from analyses conducted from cross-sectional data, from 1980 in this thesis, 1976 in Chamarette's (1981) study, and 1969-1971 in the Bolin et al. (1980) study, indicate a longitudinal trend of negative returns to earnings from military service for the Vietnam-era white veteran.

Interestingly, when using dummy-variable analysis, this thesis demonstrated significant advantages for black veterans as did Martindale et al. (1979) and Lopreato et al. (1977), while utilizing different data bases, but Chamarette (1981) and Bolin et al. (1980) reached an entirely different conclusion from analyses conducted with the same data base that this thesis used. The contradiction could be a result of any number of factors. The full-employment criteria applied in this thesis eliminated most of the individuals who were too underemployed to be considered, and earnings were reexamined after a four-year period.

Analyses utilizing counterfactual earnings equations produced findings that were consistent with those predicted for whites using the veteran dummy-variable technique but inconsistent with those for blacks. White veterans were predicted to earn more had they been non-veterans, while

white non-veterans were predicted to earn less had they been veterans; the average result was predicted \$1200 earnings disadvantage for white veterans. The findings for blacks were inconsistent: black veterans were predicted to enjoy a \$2437 earnings advantage while non-veterans were predicted to suffer a small statistically insignificant loss of \$102 for not having been veterans.

B. CONCLUSIONS

Analyses conducted in this thesis resulted in the conclusions that military service during the Vietnam-era could not be viewed as a good investment in human capital for whites, while for blacks the results were inconclusive. The findings for whites are consistent with the conclusions reached by Cutright (1972), Bolin et al. (1980), and Chamarette (1981) but fail to conclusively confirm their conclusions for blacks.

In summary, the average white veteran who entered the service during the Vietnam draft-era and completed a tour during the 1960's and 1970's has not benefited financially from his post-service employment. A selective service program that removes a person from the civilian labor force and pays a minimum wage for serving in the armed forces imposes not only a "conscription tax" but also depresses post-service earnings.

A selection bias may have resulted from the draft exemptions used during most of the 1960's which saw "better" quality whites avoiding the draft through their ability, financial or otherwise, to pursue tertiary education, while "better" quality blacks, who were unable to afford college, were less able to avoid the draft. Reaghard (1980) and Chamarette (1981) found evidence to support the conclusion that during this time "better" quality blacks were in the military, while "poorer" quality whites served. This potential bias could have confounded the attempt to capture accurate returns to earnings from prior military service for both black and white draft-era veterans.

Although this thesis has failed to reach conclusive results for black veterans, it has further identified lifetime earnings disadvantages for white veterans from the draft-era. In addition, it has identified and utilized a new methodology for examining earnings differences of veterans and non-veterans.

C. RECOMMENDATIONS

As the services compete more intensely with industry in the civilian labor market for "quality" personnel, the services will need to more fully understand the value of military service to the civilian community, in general, as well as specific areas of training in order to attract recruits. Further research is needed to examine the

possible premiums to post-service earnings of veterans who received training useful for employment in the civilian sector versus those who received no training. Additionally, service-specific effects of returns to earnings should be examined to determine which services offer recruits the greatest return on their investment.

This thesis did not use occupation as an earnings factor. The assumption was made that affirmative action programs and equal opportunity employment opportunities might have benefited black veterans more than black non-veterans. A detailed examination of labor-intense occupations where equal opportunity programs have been most successful for blacks should be undertaken to provide insight into whether in these occupations, black veterans enjoy an advantage over black non-veterans. Results for blacks in this thesis were inconclusive possibly because of the small black sample size. Further research employing the same methodology with a larger data base, including a greater number of blacks, might prove to be more conclusive than the research reported here.

APPENDIX A
HOURLY RATE OF PAY BY VETERAN STATUS BY RACE

WHITES

<u>HRPAY</u>	<u>Non-Veteran</u>	<u>Veteran</u>	<u>D.F.</u>	<u>F.</u>	<u>P.</u>
Mean	\$9.31	\$8.85	1	2.228	.1357
Std. Dev.	5.40	3.26	1615		
N	1269	348			

<u>HRPAY</u>	<u>Non-Veteran</u>	<u>Veteran</u>	<u>Row Total</u>
\$0.00 to 2.99	18 1.4	2 .6	20 1.2
\$3.00 to 3.99	42 3.3	14 4.0	56 3.5
\$4.00 to 4.99	74 5.8	15 4.3	89 5.5
\$5.00 to 5.99	137 10.8	32 9.2	169 10.5
\$6.00 to 6.99	131 10.3	42 12.1	173 10.7
\$7.00 to 7.99	140 11.0	42 12.1	182 11.3
\$8.00 to 8.99	135 10.6	42 12.1	177 10.9
\$9.00 to 9.99	119 9.4	46 13.2	165 10.2
\$10.00 to 10.99	112 8.8	37 10.6	149 9.2
\$11.00 to 11.99	86 6.8	21 6.0	107 6.6
\$12.00 to 12.99	82 6.5	18 5.2	100 6.2
\$13.00 to 50.00	193 15.2	37 10.6	230 14.2
Column Total	1269 78.5	348 21.5	1617 100.0

$\chi^2(11) = 15.24$ significance = .1718

Kolmogorov-Smirnov Test: $Z = 1.092$ significance = .184

APPENDIX A
BLACKS

<u>HRPAY</u>	<u>Non-Veteran</u>	<u>Veteran</u>	<u>D.F.</u>	<u>F.</u>	<u>P.</u>
Mean	\$7.06	\$7.28	1	.022	.8816
Std. Dev.	13.16	2.60	524		
N	440	86			

<u>HRPAY</u>	<u>Non-Veteran</u>	<u>Veteran</u>	<u>Row Total</u>
\$0.00 to 2.99	20 4.6	1 1.2	21 4.0
\$3.00 to 3.99	67 15.3	7 8.1	74 14.1
\$4.00 to 4.99	64 14.6	11 12.8	75 14.3
\$5.00 to 5.99	83 18.9	10 11.6	93 17.7
\$6.00 to 6.99	59 13.4	12 14.0	71 13.5
\$7.00 to 7.99	33 7.5	12 14.0	45 8.6
\$8.00 to 8.99	32 7.3	11 12.8	43 8.2
\$9.00 to 9.99	26 5.9	7 8.1	33 6.3
\$10.00 to 10.99	22 5.0	7 8.1	29 5.5
\$11.00 to 11.99	9 2.1	4 4.7	13 2.5
\$12.00 to 12.99	9 2.1	3 3.5	12 2.3
\$13.00 to 50.00	15 3.4	1 1.2	16 3.0
Column Total	439 83.6	86 16.4	525 100.0

$\chi^2(11) = 18.77$ significance = .0654

Kolmogorov-Smirnov Test: $Z = 1.972$ significance = .001

APPENDIX B
ANNUAL INCOME BY VETERAN STATUS BY RACE

WHITES

<u>Salary</u>	<u>Non-Veteran</u>	<u>Veteran</u>	<u>D.F.</u>	<u>F.</u>	<u>P.</u>
Mean	\$16995	\$16853	1	.052	.8196
Std. Dev.	11573	9918	2007		
N	1594	415			

<u>Salary</u>	<u>Non-Veteran</u>	<u>Veteran</u>	<u>Row Total</u>
\$0000 to 3999	268 16.8	53 12.8	321 16.0
\$4000 to 5999	34 2.1	5 1.2	39 1.9
\$6000 to 7999	47 2.9	7 1.7	54 2.7
\$8000 to 9999	49 3.1	18 4.3	67 3.3
\$10000 to 11999	92 5.8	26 6.3	118 5.9
\$12000 to 13999	118 7.4	32 7.7	150 7.5
\$14000 to 15999	114 7.2	43 10.4	157 7.8
\$16000 to 17999	120 7.5	35 8.4	155 7.7
\$18000 to 19999	123 7.7	41 9.9	164 8.2
\$20000 to 21999	127 8.0	48 11.6	175 8.7
\$22000 to 23999	88 5.5	25 6.0	113 5.6
\$24000 to 50000	414 26.0	82 19.8	496 24.7
Column Total	1594 79.3	415 20.7	2009 100.0

$\chi^2(11) = 25.30$ significance = .0082

Kolmogorov-Smirnov Test: $Z = 1.264$ significance = .082

APPENDIX B
BLACKS

<u>Salary</u>	<u>Non-Veteran</u>	<u>Veteran</u>	<u>D.F.</u>	<u>F.</u>	<u>P.</u>
Mean	\$11333	\$14395	1	12.476	.0004
Std. Dev.	7690	7073	582		
N	493	91			

<u>Salary</u>	<u>Non-Veteran</u>	<u>Veteran</u>	<u>Row Total</u>
\$0000 to 3999	74 15.0	8 8.8	82 14.0
\$4000 to 5999	22 4.5	0 0.0	22 3.8
\$6000 to 7999	61 12.4	2 2.2	63 10.8
\$8000 to 9999	66 13.4	12 13.2	78 13.4
\$10000 to 11999	56 11.4	10 11.0	66 11.3
\$12000 to 13999	57 11.6	14 15.4	71 12.2
\$14000 to 15999	44 8.9	9 9.9	53 9.1
\$16000 to 17999	27 5.5	8 8.8	35 6.0
\$18000 to 19999	20 4.1	2 2.2	22 3.8
\$20000 to 21999	22 4.5	10 11.0	32 5.5
\$22000 to 23999	12 2.4	6 6.6	18 3.1
\$24000 to 50000	32 6.5	16 11.0	48 7.2
Column Total	493 84.4	91 15.6	584 100.0

$\chi^2(11) = 29.12$ significance = .0022

Kolmogorov-Smirnov Test: Z = 1.982 significance = .001

APPENDIX C
AGE IN 1980 BY VETERAN STATUS BY RACE

WHITES

<u>Age 80</u>	<u>Non-Veteran</u>	<u>Veteran</u>	<u>D.F.</u>	<u>F.</u>	<u>P.</u>
Mean	32.11	32.97	1	25.381	0.0000
Std. Dev.	3.23	2.91	2100		
N	1667	435			

<u>Age 80</u>	<u>Non-Veteran</u>	<u>Veteran</u>	<u>Row Total</u>
28	249 14.9	11 2.5	260 12.4
29	209 12.5	33 7.6	242 11.5
30	198 11.9	52 12.0	250 11.9
31	183 11.0	72 16.6	255 12.1
32	155 9.3	69 15.9	224 10.7
33	132 7.9	32 7.4	164 7.8
34	96 5.8	23 5.3	119 5.7
35	85 5.1	23 5.3	108 5.1
36	118 7.1	43 9.9	161 7.7
37	123 7.4	42 9.7	165 7.8
38	119 7.1	35 8.0	154 7.3
Column Total	1667 79.3	435 20.7	2102 100.0

$\chi^2(10) = 79.58$ significance = 0.00

Kolmogorov- Smirnov Test: Z = 3.224 significance = 0.0

APPENDIX C
BLACKS

<u>Age 80</u>	<u>Non-Veteran</u>	<u>Veteran</u>	<u>D.F.</u>	<u>F.</u>	<u>P.</u>
Mean	32.09	32.31	1	.402	.5263
Std. Dev.	3.22	2.77	617		
N	520	97			

<u>Age 80</u>	<u>Non-Veteran</u>	<u>Veteran</u>	<u>Row Total</u>
28	76 14.6	5 5.2	81 13.1
29	70 13.5	8 8.2	78 12.6
30	70 13.5	12 12.4	82 13.3
31	43 8.3	20 20.6	63 10.2
32	44 8.5	17 17.5	61 9.9
33	36 6.9	10 10.3	46 7.5
34	44 8.5	4 4.1	48 7.8
35	40 7.7	4 4.1	44 7.1
36	26 5.0	4 4.1	30 4.9
37	31 6.0	6 6.2	37 6.0
38	40 7.7	7 7.2	47 7.6
Column Total	520 84.3	97 15.3	617 100.0

$\chi^2(10) = 31.26$ significance = .0005

Kolmogorov-Smirnov Test: Z = 1.425 significance = .034

APPENDIX D

IQ SCORE BY VETERAN STATUS BY RACE

WHITES

<u>IQ</u>	<u>Non-Veteran</u>	<u>Veteran</u>	<u>D.F.</u>	<u>F.</u>	<u>P.</u>
Mean	106.03	101.42	1	30.426	0.000
Std. Dev.	14.28	13.28	1601		
N	1236	367			

<u>IQ</u>	<u>Non-Veteran</u>	<u>Veteran</u>	<u>Row Total</u>
50 - 69	13 1.1	7 1.9	20 1.2
70 - 79	33 2.7	7 1.9	40 2.5
80 - 89	107 8.7	50 13.6	157 9.8
90 - 99	233 18.9	91 24.8	324 20.2
100 - 109	333 26.9	123 33.5	456 28.4
110 - 119	299 24.2	57 15.5	356 22.2
120 - 129	173 14.0	26 7.1	199 12.4
130 - 139	40 3.2	6 1.6	46 2.9
140 - 160	5 .4	0 0.0	5 .3
Column Total	1236 77.1	367 22.9	1603 100.0

$\chi^2(8) = 43.15$ significance = 0.00

Kolmogorov-Smirnov Test: Z = 2.957 significance = 0.0

APPENDIX D

BLACKS

<u>IQ</u>	<u>Non-Veteran</u>	<u>Veteran</u>	<u>D.F.</u>	<u>F.</u>	<u>P.</u>
Mean	86.65	89.95	1	2.053	.1532
Std. Dev.	15.91	13.66	256		
N	200	58			

<u>I.Q.</u>	<u>Non-Veteran</u>	<u>Veteran</u>	<u>Row Total</u>
50 - 69	31 15.5	4 6.9	35 13.6
70 - 79	42 21.0	7 12.1	49 19.0
80 - 89	43 21.5	15 25.9	58 22.5
90 - 99	40 20.0	19 32.8	59 22.9
100 - 109	27 13.5	8 13.8	35 13.6
110 - 119	12 6.0	5 8.6	17 6.6
120 - 129	5 2.5	0 0	5 1.9
130 - 139	0 0	0 0	0 0
140 - 160	0 0	0 0	0 0

$\chi^2(6) = 9.84$ significance = .1314

Kolmogorov-Smirnov Test: $Z = 1.280$ significance = .076

APPENDIX E

HEALTH BY VETERAN STATUS BY RACE

WHITES

<u>Healthy</u>	<u>Non-Veteran</u>	<u>Veteran</u>	<u>Row Total</u>
Good Health	1535 93.8	395 91.9	1930 93.4
Poor Health	102 6.2	35 8.1	137 6.6
Column Total	1637 79.2	430 20.8	2067 100.0

$X^2(1) = 1.71$ significance = .1912

BLACKS

<u>Healthy</u>	<u>Non-Veteran</u>	<u>Veteran</u>	<u>Row Total</u>
Good Health	448 90.5	90 93.8	538 91.0
Poor Health	47 9.5	6 6.3	53 9.0
Column Total	495 83.8	96 16.2	591 100.0

$X^2(1) = .678$ significance = .4104

APPENDIX F
MARITAL STATUS BY VETERAN STATUS BY RACE

WHITES

<u>MARSTA</u>	<u>Non-Veteran</u>	<u>Veteran</u>	<u>Row Total</u>
No Wife	343 20.6	71 16.3	414 19.7
Wife	1324 79.4	364 83.7	1688 80.3
Column Total	1667 79.3	435 20.7	2102 100.0

$\chi^2(1) = 3.68$ significance = .0550

BLACKS

<u>MARSTA</u>	<u>Non-Veteran</u>	<u>Veteran</u>	<u>Row Total</u>
No Wife	148 28.5	19 19.6	167 27.1
Wife	372 71.5	78 80.4	450 72.9
Column Total	520 84.3	97 15.7	617 100.0

$\chi^2(1) = 2.83$ significance = .0927

APPENDIX F

MARRIAGE (SPOUSE PRESENT) BY VETERAN STATUS BY RACE

WHITES

<u>Married</u>	<u>Non-Veteran</u>	<u>Veteran</u>	<u>Row Total</u>
All Others	380 22.8	81 18.6	461 21.9
Married, Spouse present	1287 77.2	354 81.4	1641 78.1
Column Total	1667 79.3	435 20.7	2102 100.0

$\chi^2(1) = 3.27$ significance = .0705

BLACKS

<u>Married</u>	<u>Non-Veteran</u>	<u>Veteran</u>	<u>Row Total</u>
All Others	207 39.8	33 34.0	240 38.9
Married, Spouse present	313 60.2	64 66.0	377 61.1
Column Total	520 84.3	97 15.7	617 100.0

$\chi^2(1) = .92$ significance = .3371

APPENDIX G
 NUMBER OF DEPENDENTS (EXCLUDING WIFE)
 BY VETERAN STATUS BY RACE

WHITES

<u>NRDEPTS</u>	<u>Non-Veteran</u>	<u>Veteran</u>	<u>D.F.</u>	<u>F.</u>	<u>P.</u>
Mean	1.59	1.61	1	.102	.7501
Std.Dev.	1.33	1.26	2095		
N	1664	433			

<u>NRDEPTS</u>	<u>Non-Veteran</u>	<u>Veteran</u>	<u>Row Total</u>
0	478 28.7	113 26.1	591 28.2
1	283 17.0	77 17.8	360 17.2
2	534 32.1	143 33.0	677 32.3
3	237 14.2	74 17.1	311 14.8
4	95 5.7	20 4.6	115 5.5
5	25 1.5	5 1.2	30 1.4
6	10 .6	0 .0	10 .5
7	2 .1	1 .2	3 .1
Column Total	1664 79.4	433 20.6	2097 100.0

$\chi^2 (7) = 6.87$ significance = .4430

Kolmogorov-Smirnov Test: $Z = .487$ significance = .971

APPENDIX G

BLACKS

<u>NRDEPTS</u>	<u>Non-Veteran</u>	<u>Veteran</u>	<u>D.F.</u>	<u>F.</u>	<u>P.</u>
Mean	2.02	1.89	1	.503	.4784
Std. Dev.	1.70	1.30	610		
N	515	97			

<u>NRDEPTS</u>	<u>Non-Veteran</u>	<u>Veteran</u>	<u>Row Total</u>
0	123 23.9	19 19.6	142 23.2
1	86 16.7	16 16.5	102 16.7
2	131 25.4	33 34.0	164 26.8
3	84 16.3	16 16.5	100 16.3
4	46 8.9	12 12.4	58 9.5
5	26 5.0	1 1.0	27 4.4
6	12 2.3	0 0.0	12 2.0
7	5 .9	0 0.0	5 .8
8	1 .2	0 0.0	1 .2
9	1 .2	0 0.0	1 .2
Column Total	515 84.2	97 15.8	612 100.0

$\chi^2(9) = 10.48$ significance = .3130

Kolmogorov-Smirnov Test: Z = .696 significance = .717

APPENDIX H
SOCIO-ECONOMIC STATUS BY VETERAN STATUS BY RACE

WHITES

<u>SES</u>	<u>Non-Veteran</u>	<u>Veteran</u>	<u>D.F.</u>	<u>F.</u>	<u>P.</u>
Mean	10.72	10.53	1	2.994	.0837
Std. Dev.	2.09	1.75	2020		
N	1603	419			

<u>SES</u>	<u>Non-Veteran</u>	<u>Veteran</u>	<u>Row Total</u>
0.0 - 5.9	41 2.6	5 1.2	46 2.3
6.0 - 8.9	232 14.5	67 16.0	299 14.8
9.0 - 9.9	241 15.0	73 17.4	314 15.5
10.0 - 10.9	326 20.3	102 24.3	428 21.2
11.0 - 11.9	333 20.8	90 21.5	423 20.9
12.0 - 15.8	430 26.8	82 19.6	512 25.3
Column Total	1603 79.3	419 20.7	2022 100.0

$\chi^2(5) = 13.96$ significance = .0159

Kolmogorov-Smirnov Test: $Z = 1.657$ significance = .008

APPENDIX H

<u>SES</u>	BLACKS		<u>D.F.</u>	<u>F.</u>	<u>P.</u>
	<u>Non-Veteran</u>	<u>Veteran</u>			
Mean	8.073	8.282	1	.661	.4166
Std. Dev.	2.256	1.824	542		
N	457	87			

<u>SES</u>	<u>Non-Veteran</u>	<u>Veteran</u>	<u>Row Total</u>
0.0 - 5.9	83 18.2	8 9.2	91 16.7
6.0 - 8.9	208 45.5	46 52.9	254 46.7
9.0 - 9.9	83 18.2	13 14.9	96 17.6
10.0 - 10.9	38 8.3	16 18.4	54 9.9
11.0 - 11.9	25 5.5	3 3.4	28 5.1
12.0 - 15.8	20 4.4	1 1.1	21 3.9
Column Total	457 84.0	87 16.0	544 100.0

$X^2(5) = 14.82$ significance = .0112

Kolmogorov-Smirnov Test: Z = 1.248 significance = .089

APPENDIX I
EDUCATION BY VETERAN STATUS BY RACE

WHITES

<u>HYGRADE</u>	<u>Non-Veteran</u>	<u>Veteran</u>	<u>D.F.</u>	<u>F.</u>	<u>P.</u>
Mean	13.83	13.35	1	11.00	.0009
Std. Dev.	2.81	2.04	2006		
N	1588	420			

<u>School</u>	<u>Non-Veteran</u>	<u>Veteran</u>	<u>Row Total</u>
Elementary	62 3.9	4 1.0	66 3.3
High School	146 9.2	23 5.5	169 8.4
High School Graduate	329 20.7	182 43.3	639 31.8
Some College	329 20.7	128 30.5	457 22.8
College Graduate	306 19.3	52 12.4	358 17.8
Higher College	288 18.1	31 7.4	319 15.9
Column Total	1588 79.1	420 20.9	2008 100.0

$\chi^2(5) = 83.29$ Significance = 0.000

<u>School</u>	<u>Non-Veteran</u>	<u>Veteran</u>	<u>Row Total</u>
Elementary	62 3.9	4 1.0	66 3.3
High School	603 38.0	205 48.8	808 40.2
College	923 58.1	211 50.2	1134 56.5
Column Total	1588 79.1	420 20.9	2008 100.0

$\chi^2(2) = 22.16$ significance = 0.000

Kolmogorov-Smirnov Test: $Z = 3.216$ significance = 0.0

APPENDIX I
BLACKS

<u>HYGRADE</u>	<u>Non-Veteran</u>	<u>Veteran</u>	<u>D.F.</u>	<u>F.</u>	<u>P.</u>
Mean	11.64	12.81	1	12.537	.0004
Std. Dev.	3.07	1.75	572		
N	481	93			

<u>School</u>	<u>Non-Veteran</u>	<u>Veteran</u>	<u>Row Total</u>
Elementary	73 15.2	1 1.1	74 12.9
High School	122 25.4	11 11.8	133 23.2
High School Graduate	148 30.8	35 37.6	183 31.9
Some College	74 15.4	39 41.9	113 19.7
College Graduate	36 7.5	3 3.2	39 6.8
Higher College	28 5.8	4 4.3	32 5.6
Column Total	481 83.8	93 16.2	574 100.0

$\chi^2(5) = 49.64$ significance = 0.000

<u>School</u>	<u>Non-Veteran</u>	<u>Veteran</u>	<u>Row Total</u>
Elementary	73 15.2	1 1.1	74 12.9
High School	270 56.1	46 49.5	316 55.1
College	138 28.7	46 49.5	184 32.1
Column Total	481 83.8	93 16.2	574 100.0

$\chi^2(2) = 23.14$ significance = 0.000

Kolmogorov-Smirnov Test: Z = 2.440 significance = 0.000

APPENDIX J
 TRAINING BY VETERAN STATUS BY RACE
 METHOD TO LEARN JOB AT WORK FROM COLLEGE BY VETERAN STATUS
 BY RACE

WHITES

<u>College</u>	<u>Non-Veteran</u>	<u>Veteran</u>	<u>Row Total</u>
Not Used	1113 71.3	335 81.1	1448 73.4
Used	448 28.7	78 18.9	526 26.6
Column Total	1561 79.1	413 20.9	1974 100.0

$X^2(1) = 15.59$ Significance = .0001

BLACKS

<u>College</u>	<u>Non-Veteran</u>	<u>Veteran</u>	<u>Row Total</u>
Not Used	391 89.9	79 90.3	470 90.0
Used	44 10.1	8 9.2	52 10.0
Column Total	435 83.3	87 16.7	522 100.0

$X^2(1) = .004$ significance = .9479

APPENDIX J
 TRAINING BY VETERAN STATUS BY RACE
 METHOD TO LEARN JOB AT WORK FROM VOCATIONAL TRAINING
 BY VETERAN STATUS BY RACE

WHITES

<u>VOCOSH</u>	<u>Non-Veteran</u>	<u>Veteran</u>	<u>Row Total</u>
Not Used	1521 93.0	386 89.6	1907 92.3
Used	115 7.0	45 10.4	160 7.7
Column Total	1636 79.1	431 20.9	2067 100.0

$\chi^2(1) = 5.09$ significance = .0240

BLACKS

<u>VOCOSH</u>	<u>Non-Veteran</u>	<u>Veteran</u>	<u>Row Total</u>
Not Used	481 96.4	83 88.3	564 95.1
Used	18 3.6	11 11.7	29 4.9
Column Total	499 84.1	94 15.9	593 100.0

$\chi^2(1) = 9.47$ significance = .0021

APPENDIX J
 TRAINING BY VETERAN STATUS BY RACE
 METHOD TO LEARN JOB AT WORK FROM OJT BY VETERAN STATUS
 BY RACE

WHITES

<u>OJT</u>	<u>Non-Veteran</u>	<u>Veteran</u>	<u>Row Total</u>
Not Used	691 42.2	163 37.8	854 41.3
Used	945 57.8	268 62.2	1213 58.7
Column Total	1636 79.1	431 20.9	2067 100.0

$X^2(1) = 2.57$ significance = .1091

BLACKS

<u>OJT</u>	<u>Non-Veteran</u>	<u>Veteran</u>	<u>Row Total</u>
Not Used	193 38.7	28 29.8	221 37.3
Used	306 61.3	66 70.2	372 62.7
Column Total	499 84.1	94 15.9	593 100.0

$X^2(1) = 2.31$ significance = .1288

APPENDIX K

HOURS WORKED PER WEEK BY VETERAN STATUS BY RACE

<u>HRSWORK</u>	WHITES		<u>D.F.</u>	<u>F.</u>	<u>P.</u>
	<u>Non-Veteran</u>	<u>Veteran</u>			
Mean	46.61	46.31	1	.297	.5857
Std. Dev.	10.18	10.70	2060		
N	1632	430			

<u>HRSWORK</u>	<u>Non-Veteran</u>	<u>Veteran</u>	<u>Row Total</u>
35 - 39 hours	73 4.5	11 2.6	84 4.1
40 - 44 hours	806 49.4	227 53.0	1033 50.2
45 - 49 hours	224 13.7	67 15.7	291 14.1
50 - 54 hours	231 14.2	57 13.3	288 14.0
55 - 59 hours	78 4.8	18 4.2	96 4.7
60 - 105 hours	218 13.4	48 11.2	266 12.9
Column Total	1630 79.2	428 20.8	2058 100.0

$\chi^2(5) = 6.42$ Significance = .2679

Kolmogorov-Smirnov Test: $Z = .651$ Significance = .791

APPENDIX K

BLACKS

<u>HRSWORK</u>	<u>Non-Veteran</u>	<u>Veteran</u>	<u>.D.F.</u>	<u>F.</u>	<u>P.</u>
Mean	43.63	42.2	1	2.858	.0914
Std. Dev.	8.06	5.6	586		
N	494	94			

<u>HRSWORK</u>	<u>Non-Veteran</u>	<u>Veteran</u>	<u>Row Total</u>
35 - 39 hours	25 5.1	2 2.1	27 4.6
40 - 44 hours	330 66.8	73 77.7	403 68.5
45 - 49 hours	55 11.1	10 10.6	65 11.1
50 - 54 hours	38 7.7	5 5.3	43 7.3
55 - 59 hours	15 3.0	2 2.1	17 2.9
60 - 105 hours	31 6.3	2 2.1	33 5.6
Column Total	494 84.0	94 16.0	588 100.0

$\chi^2(5) = 6.11$ significance = .2957

Kolmogorov-Smirnov Test: $Z = .803$ significance = .539

APPENDIX L

WEEKS EMPLOYED BY VETERAN STATUS BY RACE

WHITES

<u>WKSEMPLD</u>	<u>Non-Veteran</u>	<u>Veteran</u>	<u>D.F.</u>	<u>F.</u>	<u>P.</u>
Mean	48.09	48.91	1	2.236	.1350
Std. Dev.	10.46	9.09	2098		
N	1665	435			

<u>WKSEMPLD</u>	<u>Non-Veteran</u>	<u>Veteran</u>	<u>Row Total</u>
1 - 12 weeks	14 .9	4 .9	18 .9
13 - 25 weeks	28 1.7	8 1.9	36 1.8
26 - 38 weeks	77 4.7	14 3.3	91 4.4
39 - 44 weeks	80 4.9	19 4.4	99 4.8
45 - 48 weeks	72 4.4	20 4.7	92 4.5
49 - 51 weeks	90 5.5	23 5.3	113 5.5
52 weeks	1265 77.8	342 79.5	1607 78.2
Column Total	1626 79.1	430 20.9	2056 100.0

$\chi^2(6) = 2.11$ significance = .9097

Kolmogorov-Smirnov Test: Z = .531 significance = .941

APPENDIX L

BLACKS

<u>WKSEMPLD</u>	<u>Non-Veteran</u>	<u>Veteran</u>	<u>D.F.</u>	<u>F.</u>	<u>P.</u>
Mean	44.47	45.21	1	.203	.6523
Std. Dev.	14.77	14.71	610		
N	516	96			

<u>WKSEMPLD</u>	<u>Non-Veteran</u>	<u>Veteran</u>	<u>Row Total</u>
1 - 12 weeks	14 2.9	2 2.2	16 2.8
13 - 25 weeks	12 2.5	1 1.1	13 2.3
26 - 38 weeks	39 8.0	6 6.7	45 7.8
39 - 44 weeks	33 6.8	6 6.7	39 6.8
45 - 48 weeks	32 6.6	4 4.4	36 6.3
49 - 51 weeks	25 5.1	6 6.7	31 5.4
52 weeks	331 68.1	65 72.2	396 68.8
Column Total	486 84.4	90 15.6	576 100.0

$\chi^2(6) = 1.99$ significance = .9206

Kolmogorov-Smirnov Test: Z = .523 Significance = .947

APPENDIX M

TENURE BY VETERAN STATUS BY RACE

WHITES

<u>Tenure</u>	<u>Non-Veteran</u>	<u>Veteran</u>	<u>D.F.</u>	<u>F.</u>	<u>P.</u>
Mean	5.42	5.26	1	.365	.5459
Std. Dev.	4.88	4.56	2089		
N	1670	421			

<u>Jobyears</u>	<u>Non-Veteran</u>	<u>Veteran</u>	<u>Row Total</u>
1	384 24.6	105 24.9	489 24.7
2	150 9.6	42 10.0	192 9.7
3	151 9.7	34 8.1	185 9.3
4	96 6.2	29 6.9	125 6.3
5	82 5.3	17 4.0	99 5.0
6	96 6.2	26 6.2	122 6.2
7	32 5.3	24 5.7	106 5.4
8	92 5.9	22 5.2	114 5.8
9	64 4.1	30 7.1	94 4.7
10	64 4.1	19 4.5	83 4.2
11	70 4.5	14 3.3	84 4.2
12	52 3.3	9 2.1	61 3.1
13	40 2.6	12 2.9	52 2.6

APPENDIX M
WHITES (CONT.)

<u>Jobyears</u>	<u>Non-Veteran</u>	<u>Veteran</u>	<u>Row Total</u>
14	32 2.1	18 4.3	50 2.5
15	34 2.2	11 2.6	45 2.3
16 or more	69 4.4	9 2.1	78 3.9
Column Total	1558 78.7	421 21.3	1979 100.0

$\chi^2(15) = 22.99$ significance = .0843

Kolmogorov-Smirnov Test: $Z = .564$ significance = .908

APPENDIX M
TENURE BY VETERAN STATUS BY RACE

BLACKS

<u>Tenure</u>	<u>Non-Veteran</u>	<u>Veteran</u>	<u>D.F.</u>	<u>F.</u>	<u>P.</u>
Mean	5.36	5.66	1	.309	.5785
Std. Dev.	4.74	4.22	542		
N	456	88			

<u>Jobyears</u>	<u>Non-Veteran</u>	<u>Veteran</u>	<u>Row Total</u>
1	111 24.3	14 15.9	125 23.0
2	55 12.1	8 9.1	63 11.6
3	34 7.5	3 3.4	37 6.8
4	22 4.8	10 11.4	32 5.9
5	16 3.5	8 9.1	24 4.4
6	34 7.5	6 6.8	40 7.4
7	23 5.0	7 8.0	30 5.5
8	28 6.1	8 9.1	36 6.6
9	20 4.4	4 4.5	24 4.4
10	24 5.3	5 5.7	29 5.3
11	16 3.5	1 1.1	17 3.1
12	24 5.3	5 5.7	29 5.3
13	13 2.9	1 1.1	14 2.6

APPENDIX M

BLACKS (CONT.)

<u>Jobyears</u>	<u>Non-Veteran</u>	<u>Veteran</u>	<u>Row Total</u>
14	10 2.2	5 5.7	15 2.8
15	15 3.3	2 2.3	17 3.1
16 or more	11 2.4	1 1.1	12 2.2
Column Total	456 83.8	88 16.2	544 100.0

$\chi^2(15) = 23.61$

significance = .0721

Kolmogorov-Smirnov Test: $Z = 1.365$

significance = .048

APPENDIX N
NUMBER OF EMPLOYERS BY VETERAN STATUS BY RACE

WHITES

<u>NREMPLOY</u>	<u>Non-Veteran</u>	<u>Veteran</u>	<u>D.F.</u>	<u>F.</u>	<u>P.</u>
Mean	2.98	2.99	1	.005	.9430
Std. Dev.	2.18	2.02	1985		
N	1571	416			

<u>NREMPLOY</u>	<u>Non-Veteran</u>	<u>Veteran</u>	<u>Row Total</u>
0	263 16.7	54 13.0	317 16.0
1	180 11.5	49 11.8	229 11.5
2	241 15.3	75 18.0	316 15.9
3	278 17.7	76 18.3	354 17.8
4	224 14.3	76 18.3	300 15.1
5	185 11.8	37 8.9	222 11.2
6	102 6.5	26 6.3	128 6.4
7	55 3.5	14 3.4	69 3.5
8	24 1.5	7 1.7	31 1.6
9	12 .8	2 .5	14 .7
10	7 .4	0 .0	7 .4
Column Total	1571 79.1	416 20.9	1987 100.0

$\chi^2(10) = 12.77$ significance = .2366

kolmogorov-Smirnov Test: $Z = .695$ significance = .719

APPENDIX N

BLACKS

<u>NREMPLOY</u>	<u>Non-Veteran</u>	<u>Veteran</u>	<u>D.F.</u>	<u>F.</u>	<u>P.</u>
Mean	3.42	3.17	1	1.277	.2589
Std. Dev.	1.91	1.49	533		
N	452	83			

<u>NREMPLOY</u>	<u>Non-Veteran</u>	<u>Veteran</u>	<u>Row Total</u>
0	22 4.9	0 0.0	22 4.1
1	52 11.5	10 12.0	62 11.6
2	70 15.5	19 22.9	89 16.6
3	108 23.9	25 30.1	133 24.9
4	80 17.7	14 16.9	94 17.6
5	58 12.8	9 10.8	67 12.5
6	30 6.6	3 3.6	33 6.2
7	22 4.9	3 3.6	25 4.7
8	7 1.5	0 0.0	7 1.3
9	1 .2	0 0.0	1 .2
10	2 .4	0 0.0	2 .4
Column Total	452 84.5	83 15.5	535 100.0

$\chi^2(10) = 10.82$ significance = .3715

Kolmogorov-Smirnov Test: Z = .779 significance = .578

APPENDIX O
 UNION MEMBERSHIP BY VETERAN STATUS BY RACE

WHITES

<u>Union</u>	<u>Non-Veteran</u>	<u>Veteran</u>	<u>Row Total</u>
Member	371 85.3	122 86.5	493 85.6
Non-member	64 14.7	19 13.5	83 14.4
Column Total	435 75.5	141 24.5	576 100.0

$X^2(1) = .05$ significance = .8215

BLACKS

<u>Union</u>	<u>Non-Veteran</u>	<u>Veteran</u>	<u>Row Total</u>
Member	146 83.0	43 14.0	189 83.6
Non-member	30 17.0	7 86.0	37 16.4
Column Total	176 77.9	50 22.1	226 100.0

$X^2(1) = .089$ significance = .7664

APPENDIX P

COLLECTIVE BARGAINING BY VETERAN STATUS BY RACE

WHITES

<u>COLLBARG</u>	<u>Non-Veteran</u>	<u>Veteran</u>	<u>Row Total</u>
No	929 68.2	235 62.5	1164 67.0
Yes	433 31.8	141 37.5	574 33.0
Column Total	1362 78.4	376 21.6	1738 100.0

$\chi^2(1) = 4.09$ significance = .0432

BLACKS

<u>COLLBARG</u>	<u>Non-Veteran</u>	<u>Veteran</u>	<u>Row Total</u>
No	299 62.9	43 46.2	342 60.2
Yes	176 37.1	50 53.8	226 39.8
Column Total	475 83.6	93 16.4	568 100.0

$\chi^2(1) = 8.38$ Significance = .0038

APPENDIX Q
UNEMPLOYMENT RATE BY VETERAN STATUS BY RACE

WHITES

<u>UNEMRATE</u>	<u>Non-Veteran</u>	<u>Veteran</u>	<u>D.F.</u>	<u>F.</u>	<u>P.</u>
Mean	7.26	7.18	1	.301	.5831
Std. Dev.	2.36	2.36	1739		
N	1371	368			

<u>UNEMRATE</u>	<u>Non-Veteran</u>	<u>Veteran</u>	<u>Row Total</u>
1.9 - 3.9	71 5.2	15 4.1	86 4.9
4.0 - 4.9	144 10.5	42 11.4	186 10.7
5.0 - 5.9	239 17.4	63 17.1	302 17.4
6.0 - 6.9	201 14.7	70 19.0	271 15.6
7.0 - 7.9	247 18.0	63 17.1	310 17.8
8.0 - 8.9	265 19.3	67 18.2	332 19.1
9.0 - 9.9	54 3.9	9 2.4	63 3.6
10.0 - 11.9	77 5.6	21 5.7	98 5.6
12.0 - 13.9	62 4.5	13 3.5	75 4.3
14.0 - 18.4	11 .8	5 1.4	16 .9
Column Total	1371 78.8	368 21.2	1739 100.0

$\chi^2(9) = 8.24$ significance = .5100

Kolmogorov-Smirnov Test: Z = .744 significance = .637

APPENDIX Q

BLACKS

<u>UNEMRATE</u>	<u>Non-Veteran</u>	<u>Veteran</u>	<u>D.F.</u>	<u>F.</u>	<u>P.</u>
Mean	7.13	7.19	1	.040	.8414
Std. Dev.	2.47	2.27	512		
N	432	82			

<u>UNEMRATE</u>	<u>Non-Veteran</u>	<u>Veteran</u>	<u>Row Total</u>
1.9 - 3.9	18 4.2	2 2.4	20 3.9
4.0 - 4.9	56 13.0	8 9.8	64 12.5
5.0 - 5.9	104 24.1	20 24.4	124 24.1
6.0 - 6.9	44 10.2	14 17.1	58 11.3
7.0 - 7.9	78 18.1	15 18.3	93 18.1
8.0 - 8.9	65 15.0	15 18.3	80 15.6
9.0 - 9.9	22 5.1	0 0.0	22 4.3
10.0 - 11.9	26 6.0	2 2.4	28 5.4
12.0 - 13.9	12 2.8	6 7.3	18 3.5
14.0 - 18.4	7 1.6	0 0.0	7 1.4
Column Total	432 84.0	82 16.0	514 100.0

$\chi^2(9) = 15.65$ significance = .0746

Kolmogorov-Smirnov Test: $Z = .63$ significance = .822

APPENDIX R
REGION BY VETERAN STATUS BY RACE

WHITES

<u>Region</u>	<u>Non-Veteran</u>	<u>Veteran</u>	<u>Row Total</u>
Non-South	1108 66.5	308 70.8	1416 67.4
South	559 33.5	127 29.2	686 32.6
Column Total	1667 79.3	435 20.7	2102 100.0

$\chi^2(1) = 2.76$ significance = .0967

BLACKS

<u>Region</u>	<u>Non-Veteran</u>	<u>Veteran</u>	<u>Row Total</u>
Non South	131 25.2	33 34.0	164 26.6
South	389 74.8	64 66.0	453 73.4
Column Total	520 84.3	97 15.7	617 100.0

$\chi^2(1) = 2.83$ significance = .0926

APPENDIX S
SMSA BY VETERAN STATUS BY RACE

WHITES

<u>SMSA</u>	<u>Non-Veteran</u>	<u>Veteran</u>	<u>Row Total</u>
Non- SMSA	540 32.4	116 26.7	656 31.2
SMSA	1127 67.6	319 73.3	1446 68.8
Column Total	1667 79.3	435 20.7	2102 100.0

$\chi^2(1) = 5.01$ significance = .0252

BLACKS

<u>SMSA</u>	<u>Non-Veteran</u>	<u>Veteran</u>	<u>Row Total</u>
Non- SMSA	193 37.1	24 24.7	217 35.2
SMSA	327 62.9	73 75.3	400 64.8
Column Total	520 84.3	97 15.7	617 100.0

$\chi^2(1) = 4.96$ significance = .0259

LIST OF REFERENCES

Becker, Gary S., Human Capital, A Theoretical and Empirical Analysis with Special Reference to Education, Columbia University Press for the National Bureau of Economic Research, New York, 1975.

Bolin, P. W., Military Service and Military Vocational Training Effects on Post-Service Earnings, Master's Thesis, Naval Postgraduate School, June 1980.

Browning, H. L., Lopreato, S. C., and Poston, D. L., "Income and Veteran's Status: Variations Among Mexican Americans, Blacks, and Anglos", American Sociological Review, V. 38, p. 74-85, February 1973.

Clark, Harold F., and Sloan, Harold S., Classrooms in the Military, Bureau of Publications, Teachers College, Columbia University, New York, 1964.

Cooper, R. V. L., "Military Retiree's Post-Service Earnings and Employment", RAND Corporation Paper, R-2493-MRAL, The RAND Corporation: Santa Monica, CA, February 1981.

Cutright, P., Achievement Mobility and the Draft: Their Impact on the Earnings of Men, Social Security Administration, U.S. Department of Health, Education, and Welfare, Washington, D.C., DHEW Publication No. (SSA) 73-11854, June 1972.

Danzon, P. M., "Civilian Earnings of Military Retirees", RAND Corporation Paper, R-2353-MRAL. The RAND Corporation: Santa Monica, CA, March 1980.

DeTray, D. N., "Veteran Status as a Screening Device", American Economic Review, V. 72, Number 1, March 1982.

Fredland, J. E., and Little, R. D., "Long-Term Returns to Vocational Training: Evidence from Military Sources", Journal of Human Resources, V. 15, p. 49-66, 1980.

Fredland, J. E., and Little, R. D., "World War II Veterans: Pecuniary and Non-Pecuniary Returns To Service", an unpublished paper, 1979.

Gay, R. M. and Albrecht, M. J., "Measuring On-the-Job Performance in Military Occupations", in R.V.L. Cooper (ed.), Defense Manpower Policy: Presentations from the 1976 RAND Conference on Defense (R-2396-ARPA), RAND, December 1973.

Hess, M. W., From School to Work Via Military Service: An Improved Transition, Master's Thesis, Naval Postgraduate School, June 1980.

Lopreato, S. C. and Poston, D. L., "Differences in Earnings and Earnings Ability Between Black Veterans and Non-veterans in the United States", Social Science Quarterly, V. 57, p. 750-766, March 1977.

Martindale, M. and Poston, D. L., "Variations in Veteran/Nonveteran Earnings Patterns Among World War II, Korea, and Vietnam War Cohorts", Armed Forces and Society, V. 5, p. 219-243, Winter 1979.

Military Manpower Task Force, A Report to the President on the Status and Prospects of the All Volunteer Force, October 1982.

Mincer, J., "On-the-job Training: Costs, Returns, and Some Implications", Journal of Political Economy, V. 70, p. 50-79, October 1962.

Mincer, J., Schooling, Experience and Earnings, New York: Columbia University Press for the National Bureau of Economic Research, 1974.

Norrblom, E., The Returns to Military and Civilian Training, The RAND Corporation, R-1900-ARPA, July 1976.

Ohio State University, Center for Human Resource Research, National Longitudinal Survey of Young Men Aged 14 to 24 Codebook 1966-1980, September 1982.

Reaghard, J. A., Socioeconomic Representativeness and the Draft, Master's Thesis, Naval Postgraduate School, June 1980.

U.S. Department of Defense, Office of the Assistant Secretary of Defense (Manpower, Reserve Affairs and Logistics), Military Manpower Training Report for FY1982, Washington, D.C., March 1981.

Wonnacott, R. & Wonnacott, R., Introductory Statistics, p. 199-202, Wiley, 1977.

INITIAL DISTRIBUTION LIST

	No. Copies
1. Defense Technical Information Center Cameron Station Alexandria, Virginia 22314	2
2. Library, Code 0142 Naval Postgraduate School Monterey, California 93940	2
3. Department Chairman, Code 54 Department of Administrative Sciences Naval Postgraduate School Monterey, California 93940	1
4. Professor George W. Thomas, Code 54Te Department of Administrative Sciences Naval Postgraduate School Monterey, California 93940	12
5. Professor R. A. Weitzman, Code 54Wz Department of Administrative Sciences Naval Postgraduate School Monterey, California 93940	2
6. Lieutenant Orin P. Reams, Jr., USN 8743 Lucia Place Sun Valley, California 91352	1

**DAI
FILM**