

HD-R133 498

ADAPTIVE SIGNAL DETECTION FOR THE OPTIMAL
COMMUNICATIONS RECEIVER(U) NAVAL SURFACE WEAPONS CENTER
SILVER SPRING MD R H BARAN JUN 83 NSWC/TR-83-236

1/1

UNCLASSIFIED

F/G 17/2.1 NL

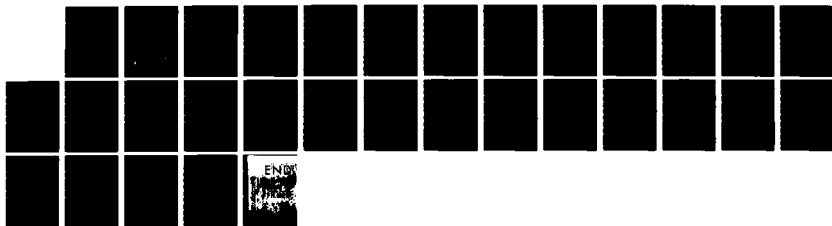

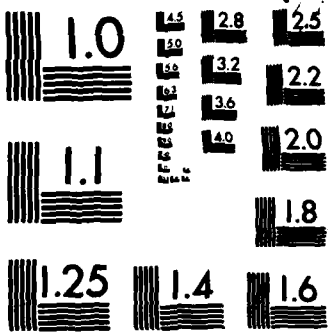

MICROCOPY RESOLUTION TEST CHART
 NATIONAL BUREAU OF STANDARDS-1963-A

NSWC TR 83-236

2

AD-A133 498

ADAPTIVE SIGNAL DETECTION FOR THE OPTIMAL COMMUNICATIONS RECEIVER

BY ROBERT H. BARAN

UNDERWATER SYSTEMS DEPARTMENT

JUNE 1983

Approved for public release, distribution unlimited

DTIC
ELECTE
S
OCT 13 1983
A



NAVAL SURFACE WEAPONS CENTER

Dahlgren, Virginia 22448 • Silver Spring, Maryland 20910

This document has been approved for public release and sale; its distribution is unlimited.

83 10 12 292

DTIC FILE COPY

UNCLASSIFIED

SECURITY CLASSIFICATION OF THIS PAGE (When Data Entered)

REPORT DOCUMENTATION PAGE		READ INSTRUCTIONS BEFORE COMPLETING FORM
1. REPORT NUMBER NSWC/TR 83-236	2. GOVT ACCESSION NO. AD-A133498	3. RECIPIENT'S CATALOG NUMBER
4. TITLE (and Subtitle) ADAPTIVE SIGNAL DETECTION FOR THE OPTIMAL COMMUNICATIONS RECEIVER		5. TYPE OF REPORT & PERIOD COVERED
7. AUTHOR(s) Robert H. Baran		6. PERFORMING ORG. REPORT NUMBER
9. PERFORMING ORGANIZATION NAME AND ADDRESS Naval Surface Weapons Center (Code 512) White Oak Silver Spring MD 20910		10. PROGRAM ELEMENT PROJECT TASK AREA & WORK UNIT NUMBERS SUSCON: TR00001; SOLAA
11. CONTROLLING OFFICE NAME AND ADDRESS		12. REPORT DATE June 1983
14. MONITORING AGENCY NAME & ADDRESS (if different from Controlling Office)		13. NUMBER OF PAGES 31
		15. SECURITY CLASS. (of this report) UNCLASSIFIED
		15a. DECLASSIFICATION/DOWNGRADING SCHEDULE
16. DISTRIBUTION STATEMENT (of this Report) Approved for public release; distribution unlimited.		
17. DISTRIBUTION STATEMENT (of the abstract entered in Block 20, if different from Report)		
18. SUPPLEMENTARY NOTES		
19. KEY WORDS (Continue on reverse side if necessary and identify by block number) Communications Radio Signal Processing		
20. ABSTRACT (Continue on reverse side if necessary and identify by block number) The problem of weak signal reception in non-Gaussian noise has been shown to have an optimal solution the structure of which involves a no-memory nonlinearity followed by a matched filter. The shape of the nonlinearity is completely determined by the noise amplitude probability density function (pdf). The assumptions underlying this theory are examined and applications to radio communication in atmospheric noise are considered. Since the likelihood ratio test on which the theory is based is		

UNCLASSIFIED

SECURITY CLASSIFICATION OF THIS PAGE (When Data Entered)

20. (Cont.)

not a robust procedure, the receiver system must adjust the shape of the nonlinearity to account for the statistics of the prevailing noise environment.

UNCLASSIFIED

SECURITY CLASSIFICATION OF THIS PAGE (When Data Entered)

FOREWORD

The Naval Surface Weapons Center's Independent Research (IR) Program is designed to stimulate original work of a basic nature and increase competence in all fields of science and technology relevant to the Center's mission.

This report documents one facet of the engineering studies performed by the author under an IR project titled, "Adaptive Signal Detection," during the first half of 1983.

Approved by:

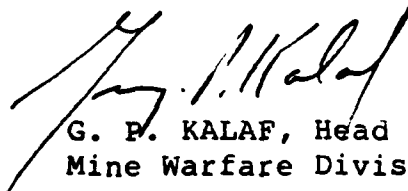

G. P. KALAF, Head
Mine Warfare Division

CONTENTS

	<u>Page</u>
SUMMARY	1
INTRODUCTION	1
LIKELIHOOD RATIO DETECTORS	5
ADAPTATION TO CHANGING ENVIRONMENTS	13
CONCLUDING REMARKS	18
REFERENCES	21

Accession For
NTIS GRA&I
DTIC TAB
Unannounced
Justification
For
Distribution/
Availability Codes
Avs
Dist

A

ILLUSTRATIONS

<u>Figure</u>		<u>Page</u>
1	EXCEEDENCE CURVE	3
2	LIKELIHOOD RATIO RECEIVER	7
3	ANTONOV'S OPTIMUM DETECTION RECEIVER	9
4	DETECTOR CHARACTERISTICS $g(x)$ FOR SEVERAL NOISE PDF'S	20

SUMMARY

The problem of weak signal reception in non-Gaussian noise has been shown to have an optimal solution the structure of which involves a no-memory nonlinearity followed by a matched filter. The shape of the nonlinearity is completely determined by the noise amplitude probability density function (pdf). The assumptions underlying this theory are examined and applications to radio communication in atmospheric noise are considered. Since the likelihood ratio test on which the theory is based is not a robust procedure, the receiver system must adjust the shape of the nonlinearity to account for the statistics of the prevailing noise environment.

INTRODUCTION

The fidelity of communications between a transmitter and receiver at opposite ends of an additive noise channel can be improved (1) by increasing the ratio of signal power to noise power, (2) by changing the form of the signal while holding power constant, or (3) by designing better noise immunity into the receiver. This publication concerns the third option with emphasis on the case in which the received signal-to-noise ratio (SNR) is low.

Kotel'nikov established four categories for the classification of noises that may interfere with radio communications: (A) sinusoidal noise, (B) impulse noise, (C) normal noise, and (D) super-positions of B- and C-type processes.¹ Impulse noise is characterized by intermittent pulses of mean duration much less than the mean interarrival time. Normal noise can be understood as a sum of independent impulsive processes so numerous that the mean interarrival

time for pulses in the sum process is much less than pulse duration. Then the instantaneous amplitude of the sum process tends to be normally distributed (so long as the variance of the pulse height is not too great). Type-D noises are those in which the number of independent impulsive processes is not sufficient, or the mean rate of pulsing is too slow, for the central limit theorems to apply. Thus the successive sample values of the type-D process may be independent and identically distributed according to a law different from the normal. Although the four categories of Kotel'nikov do not exhaust the range of possibilities, they serve to motivate a fairly general treatment of the problem of designing a communications receiver with optimal noise immunity. It should be noted that a second dimension of classification is always implicit in the characterization of interference sources, as they are either environmental or synthetic (system-generated).

An understanding of environmental noise in radio communications at frequencies up through several Megahertz evolved slowly. Eccles (1912) is cited by Austin as being first to propose that broadband atmospheric interference originated principally in lightning strokes, both locally and at great distances.² DeGroot (1917) suggested that the magnetosphere, or exosphere, is the medium through which solar winds generate atmospherics. Both hypotheses are accepted in current theory. The first demonstration that "whistlers" propagate in the exosphere was made in 1959 using Vanguard III.³ Shepelavey modelled atmospheric noise up to 20 MHz as the sum of impulsive and normal processes.⁴ In other words, if X is the amplitude due to atmospheric noise, one has $X = Y + \sigma Z$, where Z is standard normal, σ is the r.m.s. normal fluctuation, and Y is the impulsive contribution described by the two-sided power-Rayleigh distribution,

$$P(|Y| > y) = \exp(-by)^\alpha, \quad y \geq 0 \quad (1),$$

with $\alpha < 1$. Graphical presentation of atmospheric noise data is

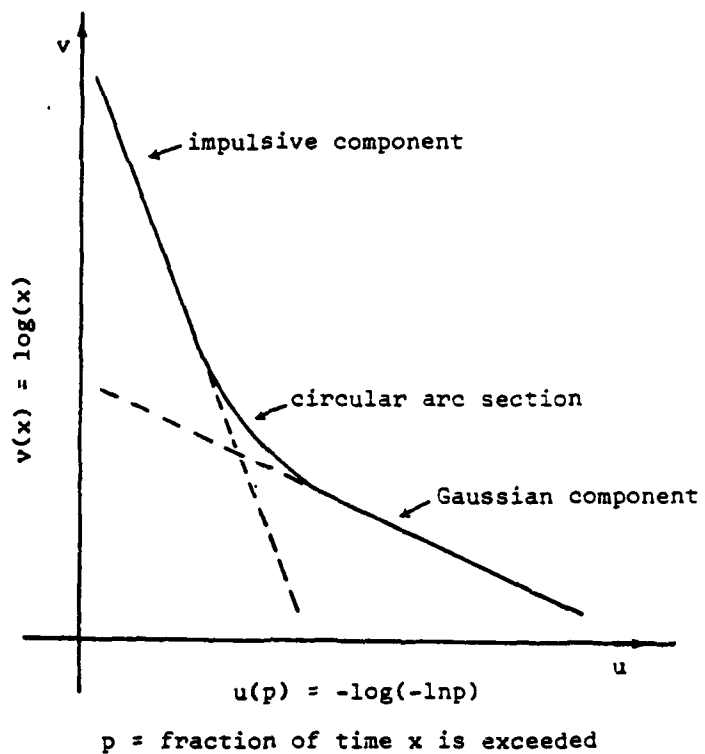

FIGURE 1. EXCEEDENCE CURVE

facilitated by plotting the coordinates

$$u = -\log(-\ln p)$$

(on the horizontal scale) and

$$v = \log(x)$$

(on the vertical scale), as shown in Figure 1, where

$$p = P(|X| > x)$$

is the probability that the absolute sample value exceeds x . The result is known as an exceedence curve and is illustrated above. Field and Lewinstein showed that, after setting $\alpha=1/4$ and adjusting b to give the right division of mean power among the two component processes, the convolution of the power-Rayleigh and normal densities gives a density, and hence an exceedence curve, which matches the ELF and VLF data extremely well.⁵

Impulse noise may also be synthetic. If communications receivers are placed near radars, impulsive interferences may occur due to direct pickup, feedback through common power supplies, or shock excitation of tuned circuits of the receiver by large modulator-generated d.c. pulses.⁶ "Ignition noise" refers to one of the earlier-known types of synthetic impulsive interference.

The treatment prescribed for impulse noise by a number of authors in the 1930's and -40's was to "silence" or "blank" the receiver. These and other terms symbolized steps in the development of the limiter concept. A short duration pulse at the input of a tuned circuit in a narrowband receiver system will produce a damped sinusoidal response with damping rate essentially determined by the "Q" of the circuit. The communication of data will be interrupted until the "ring down" waveform subsides. If a broadband amplifier feeding the tuned circuit is made to saturate at a level which is intermediate between the height of the input pulse and the nominal signal amplitude, then the effect of the noise pulse is mitigated while the signal passes undistorted. Other limiters are possible. A "hole-puncher" is obtained by making the amplifier output drop to zero when the limiting level is exceeded. A limiter would also be useful in a broadband

receiver system which integrates the input over a fixed interval to discriminate between positive and negative signal pulses of level $\pm S$. Brief noise pulses of amplitude $\pm A$, $A \gg S$, will strongly influence the result of the integration. The suppression of large excursions before integration improves fidelity. In general, a limiter is any memoryless device which, given an input x , immediately outputs $g(x)$, a function that is strictly bounded above and below. If a limiter cuts off at values of x which lie in the range of probable signal amplitudes, then the spectrum of $g(x)$ is related to that of x in a generally complicated way. The term detector usually refers to a no-memory nonlinearity which is inserted in the receiver to effect desired changes in the spectrum. For example, a diode or square law detector is used to demodulate an AM signal. It would not be wholly inconsistent with current usage to say that a generalized limiter is a detector which suppresses noise at some acceptable cost in signal distortion. Middleton gives detailed accounts of how different types of detectors perform in AM and FM receivers across the range of SNR's.⁷

LIKELIHOOD RATIO DETECTORS

Until the mid-1960's, the treatment of detectors for noise immunity enhancement was ad hoc. Development of a general theory based on the optimal properties of likelihood ratio tests appears to begin with Rappaport and Kurz who showed that, for binary synchronous communication in non-Gaussian noise, the optimal receiver consists of a two-input nonlinear device followed by an integrator and a decision box.⁸ Consider the problem of binary synchronous communication in the presence of additive noise $y(t)$ having pdf $f(y)$. It is presumed that the transmitted signal is $s_i(t)$, $i = 1$ or 2 , $-T/2 \leq t \leq T/2$. The objective is to design a receiver which, based on the sampled data $\{x_n = x(t_n), n=0,1,\dots, N\}$, where

$$x_n = s_{in} + Y_n \quad (2),$$

will decide correctly between the two hypotheses. The likelihood ratio can be expressed as the product

$$\Lambda = \sum_{n=0}^N \frac{f(x_n - s_{1n})}{f(x_n - s_{2n})} \quad (3)$$

of component ratios under certain conditions which are: either (i) the type-D or -B random process described by $f(x)$ has a mean interarrival time much greater than T , or (ii) the system bandwidth greatly exceeds the signal bandwidth. These two conditions serve to justify the factorization of the joint density which, in the strict sense, follows from the independence of the y_n . Defining

$$L_n = \log \frac{f(x_n - s_{1n})}{f(x_n - s_{2n})} \quad (4),$$

one has

$$\log \Lambda = \sum_{n=0}^N L_n \quad (5),$$

which reduces the likelihood ratio test $\Lambda \stackrel{?}{>} C$ to

$$\sum_{n=0}^N L_n \stackrel{?}{>} \log C \quad (6).$$

The conditions which justified factorization of the joint density of the $N+1$ sample values now allow a normal approximation to the distribution of $\log\Lambda$, since every L_n is well-behaved for continuous densities f . The proposed receiver is block diagrammed in Figure 2.

For square antipodal signals,

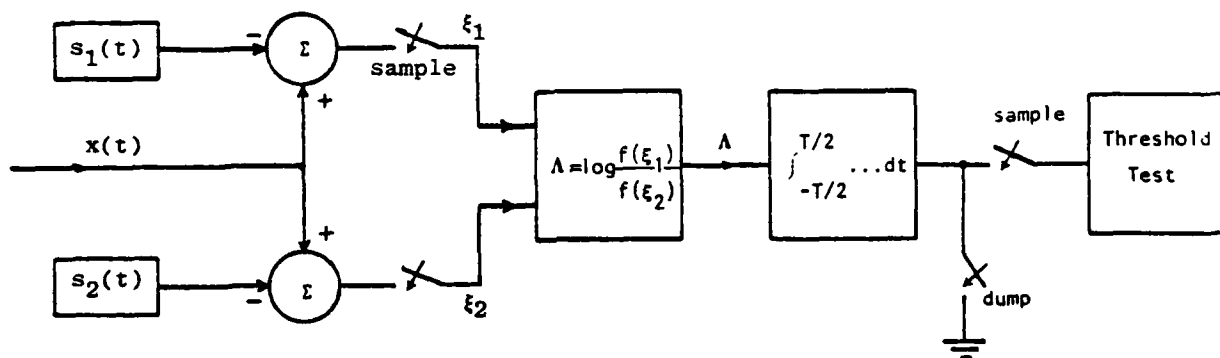

FIGURE 2. LIKELIHOOD RATIO RECEIVER

$$s_1(t) = \begin{cases} S, & -T/2 \leq t \leq T/2 \\ 0 & \text{otherwise;} \end{cases}$$

$$s_2(t) = -s_1(t) \quad (7),$$

the threshold $C=1$ corresponds to selection of s_1 when the likelihood ratio statistic is positive, s_2 when negative. The error probability is

$$P_e = P(\log\Lambda \leq 0 | i=1) = (1/2) \operatorname{erfc}(\rho/\sqrt{2}) \quad (8),$$

where

$$\rho = E(\log\Lambda | i=1) / (\text{Var}(\log\Lambda))^{1/2} \quad (9)$$

is the ratio of the mean to the standard deviation at the integrator output, which can be called the output SNR. Note that $\log\Lambda$ has the same variance for $i = 1$ or 2 when (7) applies.

Antonov (1966) proposed a more interesting treatment of the problem, beginning again with equation (3), but now testing the hypothesis $s(t)=0$ versus the simple alternative in which $s(t)$ is any nonzero real waveform.⁹ The first sum in the equation

$$\log\Lambda = \sum_{n=0}^N \log f(x_n - s_n) - \sum_{n=0}^N \log f(x_n) \quad (10)$$

is expanded in a Taylor series about the points s_n . Interchanging the order of summation and collecting terms, one has

$$\begin{aligned} \log\Lambda &= \sum_{k=1}^{\infty} \frac{(-1)^k}{k!} \sum_{n=0}^N s_n^k \frac{d^k}{dy^k} \log f(y) \Big|_{y=x_n} \\ &= \sum_{k=1}^{\infty} \phi_k \end{aligned} \quad (11)$$

For a weak signal,

$$\log\Lambda \doteq \sum_n s_n g(x_n) \quad (12)$$

to first order, where

$$g(x) = - \frac{d}{dx} \log f(x) \quad (13)$$

defines a no-memory nonlinearity (a "lagless fourpole"). The operation of the optimal first order receiver therefore consists in (1) passing x_n through a detector to produce $g(x_n)$ and (2) summing the point-by-point products of $g(x_n)$ and the stored values of the known signal. The second operation describes the response of a matched filter. Not accidentally, if $f(x)$ is the standard normal pdf, equation (13) reduces to $g(x_n) = x_n$, and the optimal first order receiver computes the sum of terms $x_n s_n$, i.e., the solution for white Gaussian noise is just a matched filter.

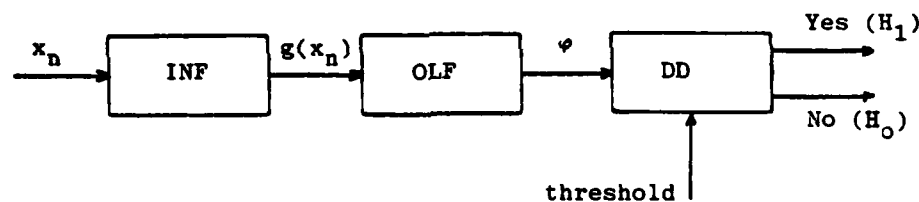

FIGURE 3. ANTONOV'S OPTIMUM DETECTION RECEIVER

Figure 3 shows Antonov's optimum detection receiver for a completely known weak signal, where INF is the nonlinear device, OLF is the optimum linear filter, and DD compares $\phi_1 = \phi$ to a threshold ϕ^* to decide between H_0 (noise only) and H_1 (signal present). It remains to show that the operating characteristic of this receiver is in fact better than that of a matched filter (OLF) alone. To this end let ψ denote the matched filter output under the tacit assumption that INF is deleted [$g(x)=x$]. Then ψ will be compared to a threshold ψ^* . When N is sufficiently large, both ψ and ϕ are approximately normal under

both H_0 and H_1 ; a solution requires computation of the conditional means and variances. Let $E_0 = E(\cdot | H_0)$, $E_1 = E(\cdot | H_1)$, and similarly for the variance operator. Three assumptions make the computation relatively straightforward. (1) The density $f(y)$ is an even function; i.e. $f(y) = f(-y)$. (2) The signal autocorrelation width is much less than interval between samples so that

$$\left(\sum_n s_n \right) s_n = S.$$

(3) The signal is smooth enough that

$$g(s_n + x_n) + s_n g'(x_n)$$

is generally valid

These assumptions lead to the results

$$\begin{pmatrix} E_0 k \varphi \\ E_1 k \varphi \end{pmatrix} = \begin{pmatrix} 0 & 0 \\ k S E_0 g^2 & S \end{pmatrix} \quad (14)$$

and

$$\begin{pmatrix} \text{Var}_0 k \varphi \\ \text{Var}_1 k \varphi \end{pmatrix} = \begin{pmatrix} k^2 S E_0 g^2 & \sigma^2 \\ k^2 S E_0 g^2 & \sigma^2 \end{pmatrix} \quad (15),$$

where k is a constant that gives $k\phi$ the same units as ψ . Of particular interest is the result for the mean of ϕ under H_1 , derived with the aid of (3). The key quantity is

$$E_0 g^2 = \int_{-\infty}^{\infty} f(x) g^2(x) dx = E_0 \phi^2 / S \quad (16).$$

Defining

$$R = S / \sigma^2 \quad (17),$$

the SNR at the output of the matched filter when ψ is considered, simple algebra shows that

$$E_0 \phi^2 = R \eta \quad (18),$$

where the number

$$\eta = \sigma^2 \int_{-\infty}^{\infty} f(x) \left[\frac{d}{dx} \log f(x) \right]^2 dx \quad (19)$$

measures the effective SNR improvement gained by using INF.¹⁰ Using the Schwartz inequality, it can be shown that

$$\eta \geq 1 \quad (20),$$

with equality if and only if the noise is Gaussian. The false alarm and detection probabilities are given explicitly by

$$Q_0 = P(\varphi > \varphi^* | H_0) = 1 - \Phi(\varphi^*/\sqrt{\eta R}) \quad (21)$$

and

$$Q_d = P(\varphi > \varphi^* | H_1) = 1 - \Phi(\varphi^*/\sqrt{\eta R} - \sqrt{\eta R}) \quad (22),$$

respectively, where

$$\Phi(z) = \int_{-\infty}^z (2\pi)^{-1/2} \exp(-t^2/2) dt.$$

Since φ^* and ψ^* are both adjusted to give the same Q_0 in the Neyman-Pearson test, one has

$$\varphi^*/\psi^* = \sqrt{\eta} \geq 1 \quad (23).$$

Now the detection probabilities are given by (22) and

$$\begin{aligned} Q_d' &= P(\psi > \varphi^*/\sqrt{\eta} | H_1) \\ &= 1 - \Phi(\varphi^*\sqrt{\eta/R} - \sqrt{R}) \end{aligned} \quad (24).$$

The assertion $Q_d' \leq Q_d$ reduces to

$$\varphi^* \geq \varphi^*/\eta - (1-1/\sqrt{\eta})R \quad (25),$$

completing the argument.

ADAPTATION TO CHANGING ENVIRONMENTS

The optimality theory outlined in the preceding paragraphs presumed foreknowledge of the first order density $f(y)$. This knowledge would allow the designer to construct a detector with the appropriate $g(x) = -\text{dlog}f(x)/\text{d}x$. A question arises concerning the effect of temporal variation in the density $f(y;t)$, where t is any time in the life cycle of the receiver system. This question concerns the robustness of the likelihood ratio test on which the theory is based, as a statistical test or estimation procedure is said to be robust if its accuracy is not too sensitive to flaws in the underlying stochastic model. No satisfactory answer of broad generality is apparent. Consequently, the designer must address the changing environment of the receiver by designing subsystems which make the receiver adapt to the noise. In other words, the optimum nonlinear receiver is inherently an adaptive device which adjusts $g(x)$ to reflect the recent history of the noise.

In order for this solution to be workable, a degree of short-term stability is required of the noise. To illustrate this point, consider the case of a multimode ergodic process $\{Y_t, -\infty < t < \infty\}$ for which

$$f(y;t) \in \{f_j(y), j = 1, \dots, J\} \quad (26)$$

for every t . The index j identifies the state of the process and, for J sufficiently large, the postulate (26) will almost surely be valid modelling assumption. If $f(y;t)$ belongs to a family of densities $f(y;\underline{\theta})$ parameterized by a vector $\underline{\theta}$, then (26) amounts to saying that the (continuous) space containing every possible $\underline{\theta}$ can be partitioned into J disjoint regions each small enough that variation within a single region is of negligible impact on the density. Then $\underline{\theta}(t)$ is approximated by the sequence of discrete states $\{j_t\}$, and $f(y;t) = f(y;\underline{\theta}(t))$ is approximated by $f_{j_t}(y)$. If the mean time between transitions from one state to the next generally exceeds the maximum length of a message, the detector which uses $g_j(x) = -\text{dlog}f(x)/dx$ will be suboptimal only on rare occasions.

Given a parametric pdf which evolves slowly enough to permit application of the theory, the designer needs to provide receiver subsystems which can estimate the distribution parameter and use the estimate to modify the detector as required. A broad range of procedures apply to the problem of probability density estimation. It is assumed that the channel is unused most of the time, so that by estimating the present density from the recent sample values of the input, the receiver really does obtain $f(y)$, and not the density of $y(t)+s(t)$. Since $s(t)$ is known, a corresponding pdf,

$$f_s(x) = \frac{d}{dx} P(s(t) \leq x) \quad (27),$$

is known; and the density $f_{s+y}(x)$ of the signal plus noise can in principle be used to get $f(y)$ by solving the integral equation

$$f_{s+y}(x) = \int_{-\infty}^{\infty} f_s(x-y) f(y) dy \quad (28)$$

for $f(y)$. Yet if the receiver does not have access to a fairly sophisticated computer, one would not want to address this issue. Besides, if message length is much less than the period of time over which the input is sampled to estimate $\underline{\theta}$, the presence or absence of the weak signal in some of the samples will not strongly influence the result.

Three approaches to pdf estimation were considered by Evans, who addressed the present problem of finding $g(x)$ for Antonov's receiver.¹¹ Distribution-Independent Linear Smoothing computes

$$f(x) = \int_{-u/2}^{+u/2} w_n(x-y) dF_n(y) \quad (29)$$

from the accumulated histogram F_n of n sample values. The smoothing function w_n is suitably well behaved and even on the interval $(-u/2, +u/2)$ and it approaches a delta function as $n \rightarrow \infty$. Partially Distribution-Independent Linear Smoothing uses a function w_n in (29) which has been selected to minimize the variance of f_n over a given family of density functions.

Evans used the term Distribution-Dependent Smoothing to describe the case in which one assumes a model $f(x;\underline{\theta})$ and estimates $\underline{\theta}$ using techniques such as maximum likelihood or the method of moments. Application of these two techniques to the power-Rayleigh distribution introduced in Equation (1) is a straightforward exercise.* If Y is the random variable and $\alpha=1/m$, the first two moments are $EY = m!/b$ and $EY^2 = b^{-2}\Gamma(2m+1)$. The method of moments prescribes the estimates $\hat{b} = \hat{m}!/\bar{Y}$, where \bar{Y} is the sample mean, and \hat{m} such that

*Here Y corresponds to the $|Y|$ of equation (1).

$$\bar{y}^2 / (\bar{y})^2 = \Gamma(2\hat{m}+1) / (\hat{m}!)^2 \quad (30),$$

where \bar{y}^2 is the sample second moment. Solving (30) for \hat{m} , the result can be substituted into the equation for \hat{b} .

The maximum likelihood estimators of α and b are considerably more complicated. One ends up with the simultaneous equations

$$n/\hat{\alpha} = \sum_{i=1}^n (1 - (\hat{b}y_i)^{\hat{\alpha}}) \ln y_i$$

and

$$n = \sum_{i=1}^n [\hat{b}y_i]^{\hat{\alpha}}$$

for sample values y_1, \dots, y_n .

Without an assumed parametric model and beginning with a smoothed, normalized histogram $p(x)$ that has been derived from old data, an updated pdf estimate $q(x)$ could be obtained using the method of minimum cross-entropy described by Shore.¹² Let the true pdf be $f(x)$. A set of linear equality constraints,

$$\int f(x) e_j(x) dx = d_j, \quad j = 1, \dots, K \quad (31),$$

together with

$$\int q(x) dx = 1 \quad (32),$$

lead to the result

$$q(x) = p(x) \exp(-\lambda - \sum_{j=1}^K \beta_j e_j(x)) \quad (33),$$

for unknown Lagrange multipliers λ and $\{\beta_j\}$. The method of minimum cross-entropy selects that $q(x)$ which minimizes

$$H(q,p) = \int q(x) \log [q(x)/p(x)] dx \quad (34).$$

The cross-entropy at the minimum can be expressed in terms of the Lagrange multipliers as

$$\min H(q,p) = -\lambda - \sum_{j=1}^K \beta_j d_j \quad (35).$$

For example, one could have, for $K=2$, that d_1 and d_2 are the first two moments of the distribution. Then the equations

$$\int p(x) (x-d_1) \exp(-\beta_1 x - \beta_2 x^2) dx = 0,$$

$$\int p(x) (x^2-d_2) \exp(-\beta_1 x - \beta_2 x^2) dx = 0,$$

and

$$\lambda = \log \int p(x) \exp(-\beta_1 x - \beta_2 x^2) dx$$

could be solved for the Lagrange multipliers. Unfortunately, this too is a rather computation-intensive procedure.

CONCLUDING REMARKS

The optimality theory outlined above can be illustrated with a reasonably simple example. Referring back to Shepelavey's atmospheric noise model (page 2), let the sample value of the noise be $X = Y + cZ$ with the two-sided power-Rayleigh distribution of Y having $\alpha=1$. (Let c denote the r.m.s. normal noise.) Then

$$f(y) = (1/2)b \exp(-b|y|) \quad (36)$$

is the bilateral exponential density with $EY^2 = 2b^{-2}$. For $c=0$, the optimal detector has

$$g^{(0)}(x) = b \operatorname{sgn}(x) \quad (37),$$

which describes a "hard limiter"; and, for $c=1$,

$$g^{(1)}(x) = x$$

as noted previously. Every intermediate case

$$g^{(c)}(x), \quad 0 < c < 1,$$

requires evaluation of a convolution integral

$$f_X(x) = \int_{-\infty}^{\infty} f(x-y) e^{-y^2/2c^2} dy / \sqrt{2\pi}c \quad (38).$$

It is a straightforward exercise to program a desktop computer to evaluate (38) for a number of cases subject to the mean power constraint

$$c^2 + 2/b^2 = 1 \quad (39).$$

Figure 4 shows the shape of the optimal $g^{(c)}(x)$ for $c^2 = 0.975, 0.50, 0.25, 0.125,$ and 0.05 . These graphs appear to be consistent with the requirement that $g(x)$ approach (37) as $c \rightarrow 0$. The table of $\text{SIGMA}^2 = c^2$ versus $\text{IMP} = \eta$, inset in the figure, gives the computed SNR improvement factors obtained from the integral in equation (19), with $\sigma^2=1$. The accuracy of the computation is clearly not too good in this respect. (For $c=1$ the result should be $\eta=1$.) Yet the trend is towards increasing η as the non-Gaussian fraction increases. For $b = \sqrt{2}$, the exact solution is $\eta=2$.

Using smoothed sample pdf's derived from ELF atmospheric noise data, Evans and Griffiths found the SNR improvement factor to be generally on the order of a few dB. In light of the difficulties involved in designing an adaptive optimal detector, they chose to consider various kinds of fixed limiters for their hypothetical ELF receiver. The rapid advances in microcomputer technology over the intervening decade, however, could justify a re-evaluation of their conservative conclusion.

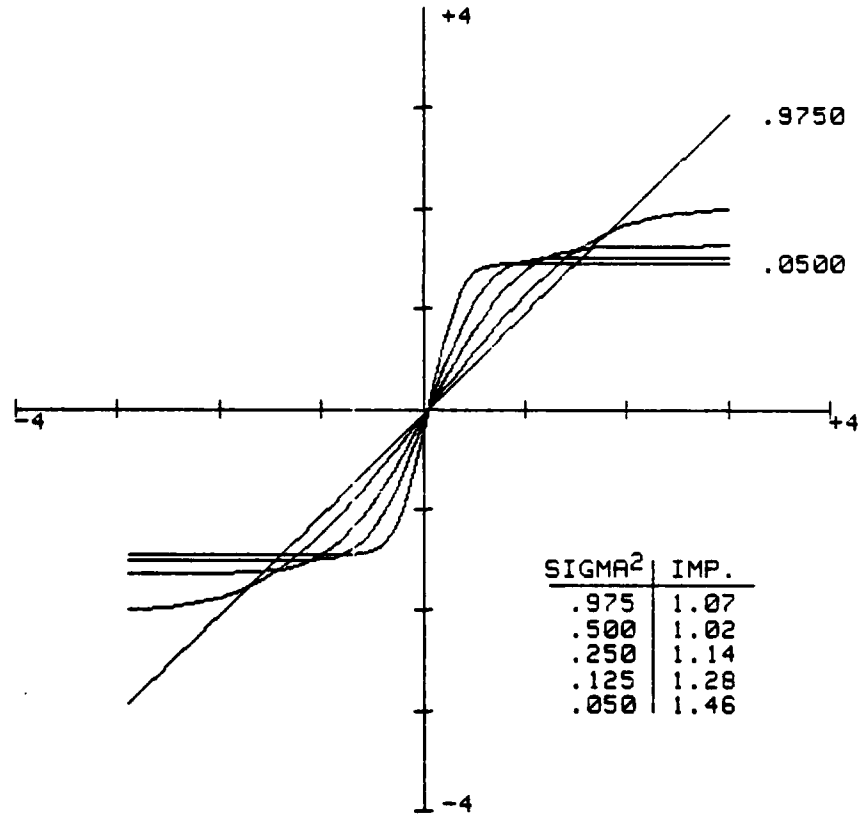

FIGURE 4. DETECTOR CHARACTERISTICS $g(x)$ FOR SEVERAL NOISE PDF'S

REFERENCES

1. V. A. Kotel'nikov, The Theory of Optimum Noise Immunity, translated by R. A. Silverman, McGraw-Hill (1959).
2. L. W. Austin, "The Present Status of Radio Atmospheric Disturbances," IRE Proceedings, 14, 1926, p. 133.
3. G. McK. Allcock, "Whistlers," Progress in Radio Science 1960-63, Vol. IV, Elsevier, 1965.
4. B. Shepelavey, "Non-Gaussian Atmospheric Noise in Binary-Data, Phase-Coherent Communications Systems," IEEE COM-11, 1963, p. 280.
5. E. C. Field and M. Lewinstein, "Amplitude-Probability Distribution Model for ELF/VLF Atmospheric Noise," IEEE COM-26, No. 1, 1978, p. 83.
6. R. Engels, "An Impulse Interference Blanker for Communications Receivers," IRE Trans. Communications Systems, CS-4, #3, 1956, p. 22.
7. D. Middleton, An Introduction to Statistical Communication Theory (McGraw-Hill, 1960).
8. S. S. Rappaport and L. Kurz, "An Optimum Nonlinear Detector for Digital Data Transmission through Non-Gaussian Channels," IEEE COM-14, 1966, p. 26.

REFERENCES (Cont.)

9. O. Antonov, "Optimum Detection of Signals in Non-Gaussian Noise," Radio Engineering and Electronic Physics, Vol. 12, 1966, p. 541.
10. J. E. Evans and A. S. Griffiths, "Design of a Sanguine Noise Processor Based on Worldwide ELF Recordings," IEEE COM-22, 1974, p. 528.
11. J. E. Evans, "Probability Density Function Estimation (with applications for receiver design for reception in non-Gaussian noise)," Tech. Note 1969-47, Lincoln Lab., M.I.T., 1972, DDC AD-741824.
12. J. E. Shore, "Cross-Entropy Minimization Given Fully Decomposable Subset of Aggregate Constraints," IEEE IT-28, No. 6, 1982, p. 956.
13. J. E. Shore and R. M. Gray, "Minimum Cross-Entropy Pattern Classification and Cluster Analysis," IEEE PAMI-4, No. 1, 1982, p. 11.

DISTRIBUTION

	<u>Copies</u>		<u>Copies</u>
Office of the Under Secretary of Defense for Research and Engineering Attn: Honorable R. D. LeLauer Rm 3E1006, The Pentagon Washington, DC 20301	1	Commander Naval Electronics Systems Command Attn: Technical Library Department of the Navy Washington, DC 20360	1
Chief of Naval Material Attn: ADM J. G. Williams, Jr. (MAT-00) Department of the Navy Washington, DC 20360	1	Commander Naval Ocean Systems Center Attn: Technical Library San Diego, CA 92152	1
Office of Naval Research Attn: Technical Library Arlington, VA 22217	2	Commanding Officer Naval Underwater Systems Center Attn: Technical Library Newport, RI 02844	1
Commanding Officer Office of Naval Research Branch Office 495 Summer Street Boston, MA 02210	1	Commander Naval Weapons Center Attn: Technical Library China Lake, CA 93555	1
Commanding Officer Officer of Naval Research Branch Office Attn: Dr. George Sandoz 536 South Clark Street Chicago, IL 60605	1	Superintendent Naval Postgraduate School Attn: CDR E. J. Mahon (Curricular Officer for Weapons, Engineering, and ASW) Monterey, CA 93940	1
Commander Naval Air Systems Command Attn: Technical Library Department of the Navy Washington, DC 20361	1	Commanding Officer Naval Research Laboratory Attn: Code 1000 Technical Library Washington, DC 20375	1 1
Commander Naval Sea Systems Command Attn: Technical Library (99612) RADM D. M. Jackson (SEA-06) Washington, DC 20362	2 1	Defense Technical Information Center Cameron Station, Building 5 Alexandria, VA 22314	2

DISTRIBUTION (Cont.)

Copies

Internal Distribution:

U12 (R. H. Baran)	10
R43 (D. G. Jablonski)	1
R43 (G. Gaunard)	1
U21 (P. D. Jackins)	1
R04 (D. L. Love)	1
U12 (J. D. Sherman)	1
R43 (J. F. Scarzello)	1
R42 (E. G. Powell)	1
E431	9
E432	3
E35	1

