

ADA133686

MEMORANDUM REPORT ARBRL-MR-03303

COMPUTER AIDED DESIGN OF POLYHEDRON  
SOLIDS TO MODEL AIR IN  
COM-GEOM DESCRIPTIONS

James E. Shiells

August 1983



**US ARMY ARMAMENT RESEARCH AND DEVELOPMENT COMMAND**  
**BALLISTIC RESEARCH LABORATORY**  
**ABERDEEN PROVING GROUND, MARYLAND**

Approved for public release; distribution unlimited.

DTIC QUALITY INSPECTED 3

Destroy this report when it is no longer needed.  
Do not return it to the originator.

Additional copies of this report may be obtained  
from the National Technical Information Service,  
U. S. Department of Commerce, Springfield, Virginia  
22161.

The findings in this report are not to be construed as  
an official Department of the Army position, unless  
so designated by other authorized documents.

*The use of trade names or manufacturers' names in this report  
does not constitute endorsement of any commercial product.*

UNCLASSIFIED

SECURITY CLASSIFICATION OF THIS PAGE (When Date Entered)

REPORT DOCUMENTATION PAGE		READ INSTRUCTIONS BEFORE COMPLETING FORM	
1. REPORT NUMBER MEMORANDUM REPORT ARBRL-MR-03303	2. GOVT ACCESSION NO.	3. RECIPIENT'S CATALOG NUMBER	
4. TITLE (and Subtitle) COMPUTER AIDED DESIGN OF POLYHEDRON SOLIDS TO MODEL AIR IN COM-GEOM DESCRIPTIONS		5. TYPE OF REPORT & PERIOD COVERED Final	
		6. PERFORMING ORG. REPORT NUMBER	
7. AUTHOR(s) James E. Shiells		8. CONTRACT OR GRANT NUMBER(s)	
9. PERFORMING ORGANIZATION NAME AND ADDRESS US Army Ballistic Research Laboratory ATTN: DRDAR-BLV Aberdeen Proving Ground, MD 21005		10. PROGRAM ELEMENT, PROJECT, TASK AREA & WORK UNIT NUMBERS	
11. CONTROLLING OFFICE NAME AND ADDRESS US Army Armament Research & Development Command US Army Ballistic Research Laboratory (DRDAR-BLA-S) Aberdeen Proving Ground, MD 21005		12. REPORT DATE August 1983	
		13. NUMBER OF PAGES 45	
14. MONITORING AGENCY NAME & ADDRESS (if different from Controlling Office)		15. SECURITY CLASS. (of this report) Unclassified	
		15a. DECLASSIFICATION/DOWNGRADING SCHEDULE	
16. DISTRIBUTION STATEMENT (of this Report) Approved for public release; distribution unlimited.			
17. DISTRIBUTION STATEMENT (of the abstract entered in Block 20, if different from Report)			
18. SUPPLEMENTARY NOTES			
19. KEY WORDS (Continue on reverse side if necessary and identify by block number) Computerized Simulation Model Target Description Model Target Vulnerability Analysis Internal Target Air Computer Code (CADAIR)			
20. ABSTRACT (Continue on reverse side if necessary and identify by block number) Certain target vulnerability analysis performed at BRL require (COM-GEOM) simulations which include internal air in the description. This report describes an interactive program which aids the user in describing such internal air. A simple example is included in this report in which the procedure is described in a step-by-step fashion.			

## TABLE OF CONTENTS

	Page
LIST OF ILLUSTRATIONS . . . . .	5
I. INTRODUCTION . . . . .	7
II. BACKGROUND . . . . .	7
III. TARGET DESCRIPTION . . . . .	8
IV. CADAIR PROGRAM OVERVIEW . . . . .	12
V. CADAIR PROGRAM USER GUIDE . . . . .	13
VI. ARS COORDINATE TRANSLATION . . . . .	23
VII. DISCUSSION . . . . .	25
APPENDIX A - Combinatorial Geometry Background . . . . .	27
APPENDIX B - CADAIR Program Listing . . . . .	33
DISTRIBUTION LIST . . . . .	43

## LIST OF ILLUSTRATIONS

Figure	Page
1 Basic ARS Solid . . . . .	8
2 Example of Large ARS Solid . . . . .	9
3 Example of Air Modeling Errors in COM-GEOM Description . . . . .	10
4 Example of Acceptable Modeling of Air in a COM-GEOM Description . .	10
5 Inverted Tumbler Cross-Cuts . . . . .	11
6 Title Replacement Format for XSECT Input . . . . .	12
7 MFB Commands to Access CADAIR Program at BRL . . . . .	13
8 CADAIR MENU . . . . .	14
9 DISPLAY Cross-Section Example . . . . .	15
10 DISPLAY Perspective View Example . . . . .	16
11 Inverted Tumbler - First Display . . . . .	18
12 Inverted Tumbler - Second Display . . . . .	18
13 Inverted Tumbler - Second Display - End . . . . .	19
14 Inverted Tumbler - Third Display - Start . . . . .	19
15 Inverted Tumbler - Third Display - Midway . . . . .	20
16 Perspective View of Completed ARS Solid . . . . .	20
17 ZOOM Example - Start . . . . .	22
18 ZOOM Example - Result . . . . .	22
19 Plane Card for XSECT Option . . . . .	23
20 XSECT Plot Defined by COM-GEOM Coordinates . . . . .	24
21 Turret Cross-Cut . . . . .	26

## APPENDIX A

A-1 Intersection (+), Subtraction (-), Union (OR) of Solids . . . . .	31
---	----

## I. INTRODUCTION

Vulnerability/lethality analyses performed at the Ballistic Research Laboratory (BRL) generally require a computer description of the target under investigation. The target simulation is most often accomplished through a method known as combinatorial geometry (COM-GEOM). The resulting target descriptions are commonly referred to as COM-GEOM<sup>1,2</sup> descriptions. The COM-GEOM technique for target descriptions employs a variety of basic geometric solids in order to model all of<sup>3</sup> the components of the target. The BRL tank vulnerability program<sup>3</sup> is routinely used to estimate the vulnerability of many armored targets. In particular, this program requires the COM-GEOM target descriptions to include internal air modeled in the description.

This report describes the interactive program CADAIR which aids the user in describing internal air for COM-GEOM descriptions. The program is useful during the creation phase of a COM-GEOM description or in modifying an earlier COM-GEOM description which lacked internal air. In addition, various other capabilities of the CADAIR program are discussed.

## II. BACKGROUND

The BRL tank vulnerability computer program (VAMP) is based on the "compartment model" of vehicle vulnerability. In this lethality model, damage correlations for entire compartments are considered in order to arrive at final kill probabilities for the target. Usually the vehicle is divided into two compartments: the engine compartment and the crew compartment. It has been found convenient to identify "compartments" by describing the compartment air in the COM-GEOM description. The target description air is merely coded in order to distinguish the crew compartment (02) from the engine compartment (05). Special other compartments may similarly be identified by this technique.

---

<sup>1</sup>L. Bain and M. Reisinger, "The GIFT Code User Manual, Volume I, Introduction and Input Requirements," BRL Report No. 1802, July 1975 (Unclassified) (AD B006037L).

<sup>2</sup>G. Kuehl, L. Bain and M. Reisinger, "The GIFT Code User Manual, Volume II, The Output Options," BRL Report ARBRL-TR-02189, September 1979 (Unclassified) (AD A078364).

<sup>3</sup>C. Nail and T. Bearden, "Vulnerability Analysis Methodology Program (VAMP) A Combined Compartment-Kill Vulnerability Program," Computer Sciences Corporation, October 1979 (Unclassified).

### III. TARGET DESCRIPTION

A brief summary of the COM-GEOM technique is presented in Appendix A. The descriptions utilize a variety of basic geometric solids for describing the actual target. The solid types currently available for building COM-GEOM descriptions are listed in Table A-1. These solids, with the exception of the ARS, are fundamentally simple geometric shapes. The ARS (triangular surfaced polyhedral solid) may be used to model extremely complex shapes. Figure 1 illustrates the essential characteristics of the ARS solid.

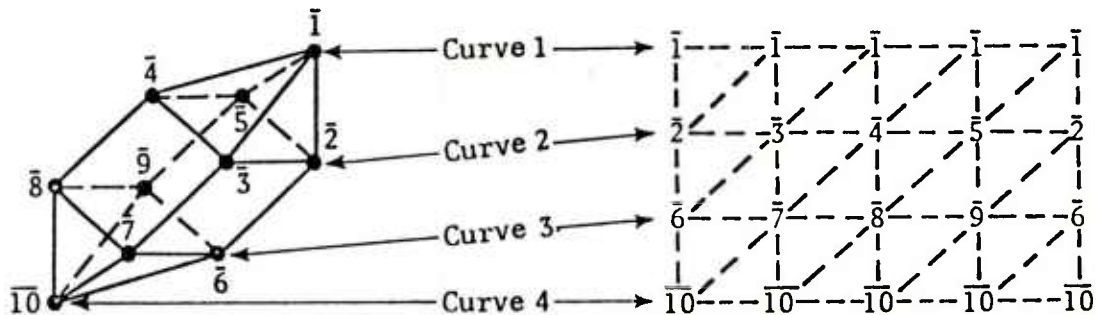

**SPECIFY:** The X, Y, Z coordinate values of the vertices of the concave or convex polyhedron. Either 1) order and record the vertices by the number of curves (M) and number of points per curve (N) system or 2) order and record the vertices by the scheme associated with the SHOT GENERATOR Code and specify the number of recorded points (ND).

Figure 1. Basic ARS Solid

Both the number of curves and number of points per curve may vary considerably from that shown in Figure 1. An example of the possible complexity of the ARS solid is shown in Figure 2 which depicts an entire surface of a tank turret. The versatility of the ARS solid makes it ideally suited for describing interior air in target descriptions.

In order to avoid errors, the user must exercise caution when modeling air in the COM-GEOM description. Figure 3 shows a cross section of a tank turret which has two types of errors that may occur if the internal air is modeled incorrectly. If the internal air (bounded by solid line) does not "fill up" the interior compartment volume or if it "spills over" the exterior surface of the compartment, then errors will occur during further computer processing. An acceptable modeling technique for internal air is illustrated in Figure 4. Note in this figure that the boundary of the internal air is defined within the shell wall which identifies the compartmentalized volume.

In view of these constraints and the previously noted versatility of the ARS solid, it therefore is apparent that this solid type is well suited

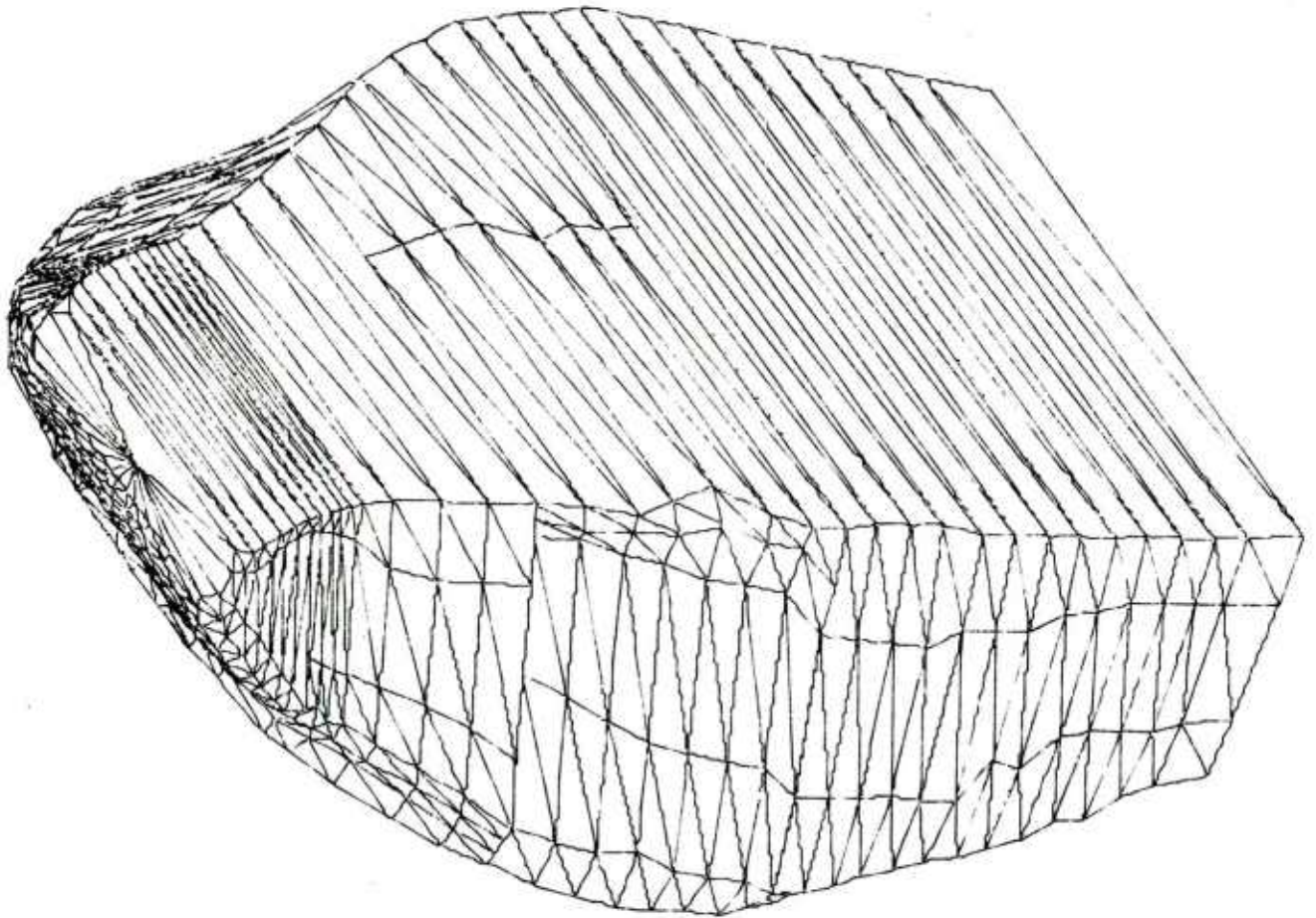

Figure 2. Example of Large ARS Solid

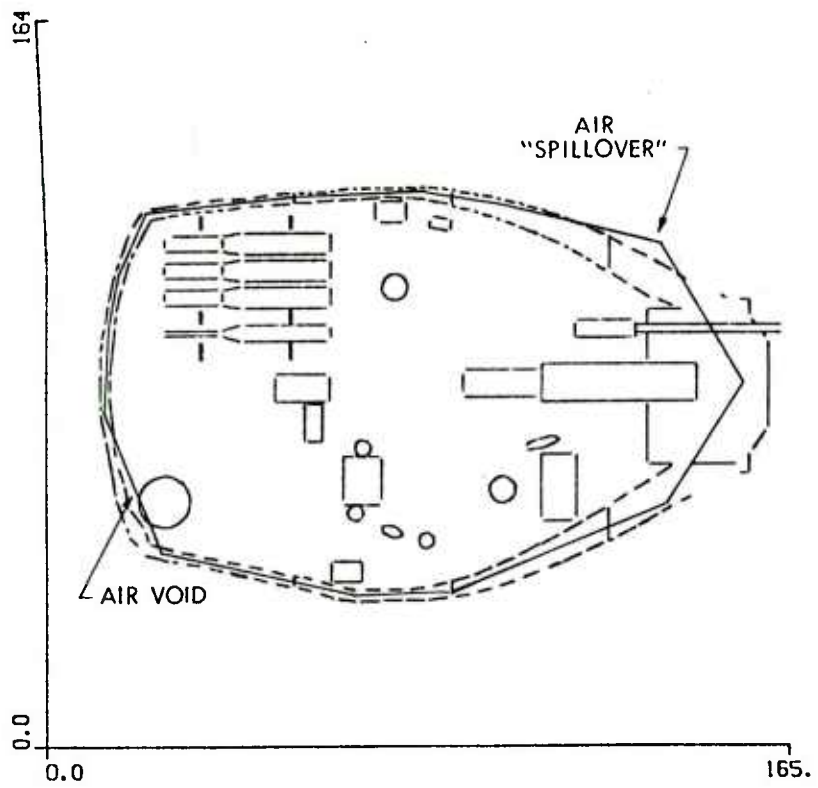

Figure 3. Example of Air Modeling Errors in COM-GEOM Description

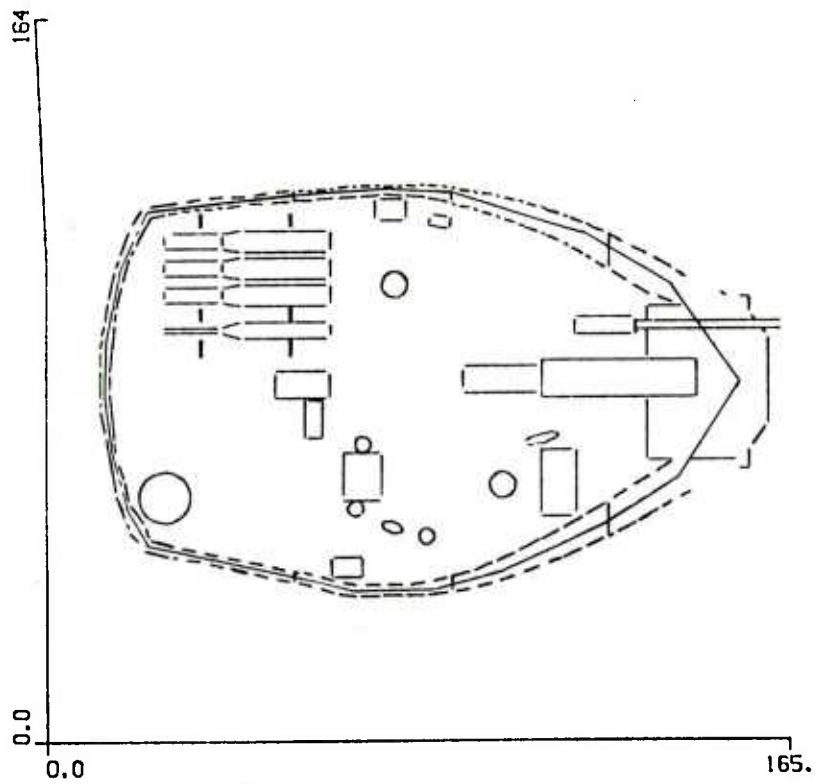

Figure 4. Example of Acceptable Modeling of Air in a COM-GEOM Description

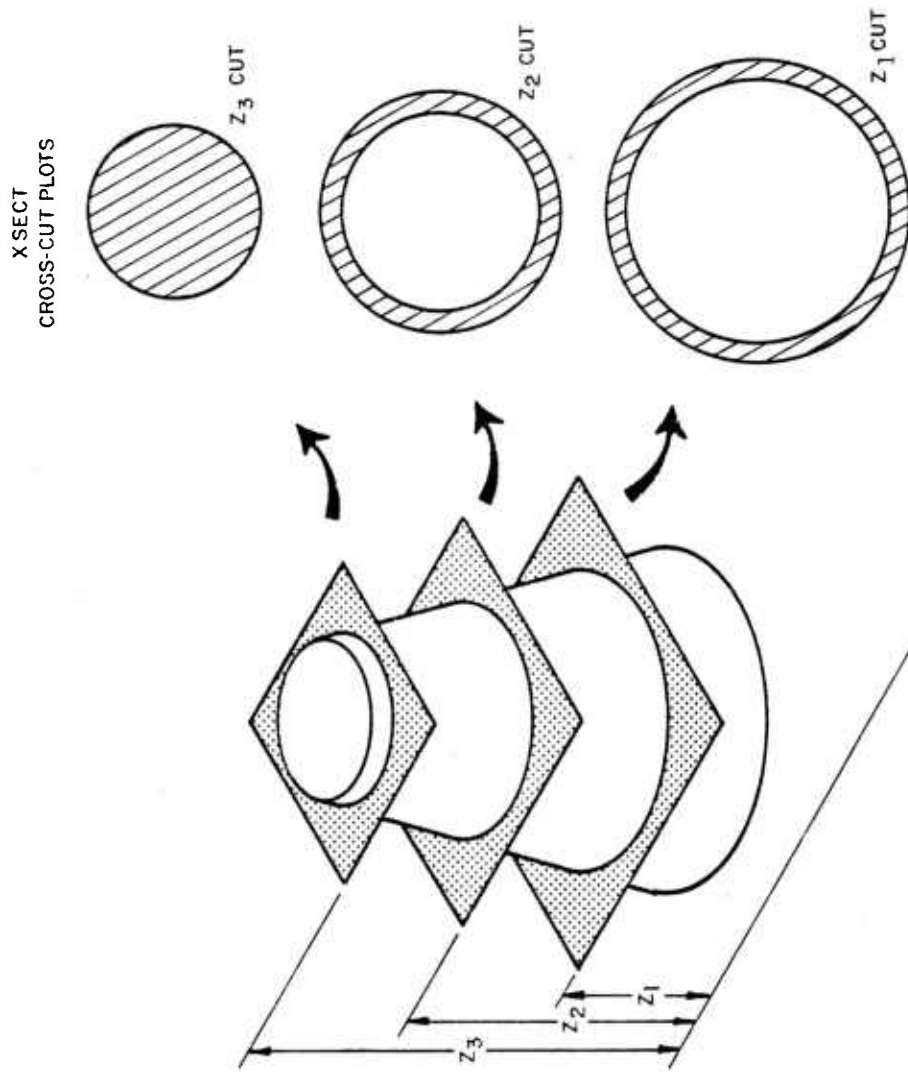

Figure 5. Inverted Tumbler Cross-Cuts

for modeling internal air. The purpose of the CADAIR program is to aid the user in constructing an ARS solid which will conform to the aforementioned requirements.

#### IV. CADAIR PROGRAM OVERVIEW

CADAIR is an interactive graphics program for use with a TEKTRONIX<sup>R</sup> terminal operating within the NOS (version 1.4) environment. The Network Operating System (NOS) controls the operation of CDC CYBER 170 series, CDC CYBER 70, Models 71, 72, 73, and 74, and CDC 6000 series computer systems. CADAIR is a FORTRAN program which requires the library software package DISSPLA<sup>R</sup> which is a proprietary product of ISSCO<sup>4</sup>. The program CADAIR listed in Appendix B is currently used at BRL in conjunction with a TEKTRONIX<sup>R</sup> model 4010 terminal operating at 9600 baud.

CADAIR requires input which is generated from the GIFT<sup>2</sup> code under option XSECT. This option produces plot files which define cross-sectional views of the COM-GEOM description. Reference 2 is recommended for the reader unfamiliar with the XSECT option of the GIFT code. An example of this type of plot for the case of a simple inverted tumbler is illustrated in Figure 5.

The use of the CADAIR program for describing air within the inverted tumbler (Figure 5) will serve as an example in the following section. The user is free to select any number and location of cross-cuts when using the XSECT option of the GIFT code. The judicious selection of cutting planes which reflect "moderate" changes between succeeding cross-cut shapes is recommended. In the normal use of the XSECT option, there is no information relating to the position of the cutting plane (Z value) available in the plot file output. This third coordinate information (Z values) is clearly vital for describing an ARS solid in three dimensional space. However, a simple method for accomplishing this is readily available. The regular XSECT plot title may be replaced with the number of cutting planes and their respective locations (Z values). Figure 6 shows the prescribed format to be used for replacing the TITLE card for the XSECT option of the GIFT code.

I5	F5.0	F5.0	F5.0		....	F5.0
NUM	Z1	Z2	Z3		....	Zn

- NUM- Total number of cross-cuts in plot file  
(not to exceed 20)
- Zi- Cutting plane position ( Z-value )  
for i th cross cut in the COM-GEOM  
coordinate system

Figure 6. Title Replacement Format for XSECT Input

<sup>4</sup>Integrated Software Systems Corporation, ISSCO<sup>R</sup>, San Diego, CA 92121

The CADAIR graphics program displays each of the cross-sectional plots on the graphics screen and prompts the user to select points for each ARS curve. The user inputs the (X, Y) values for these points by manipulating the position of the cross hairs that appear on the graphics screen. Advantage from visual feedback thereby aids the user in fitting the ARS curve entirely within the shell wall boundary around the internal compartment. The user may save the ARS data file (punch) thus created at the conclusion of the point selection procedure from each cross-cut plot. This file is appropriately formatted for use in a COM-GEOM description.

#### V. CADAIR PROGRAM USER GUIDE

The CADAIR program currently in use at BRL is accessed by entering the commands that are listed in Figure 7 on a TEKTRONIX<sup>R</sup> 4010.

```
GET,TAPE12=PLTFILE/UN=SHIELLS
ATTACH,DISSPLA/UN=DISSPLA
LIBRARY,DISSPLA
GET,GOX/UN=SHIELLS
GOX
```

Figure 7. MFB Commands to Access CADAIR Program at BRL

In Figure 7, PLTFILE is the plot file output from the XSECT option of the GIFT code that was discussed in the previous section. File DISSPLA is the proprietary graphics software product of ISSCO. In Figure 7, GOX is the binary file which contains the compiled CADAIR program.

When the last command in Figure 7 is entered on the terminal keyboard, the screen is cleared and the MENU is displayed.

Figure 8 shows a copy of the MENU which appears on the graphics terminal. The terminal cross hairs also become visible at this time. A keyboard response from the terminal user is required whenever the cross hairs become visible.

The required response generally requires the user to change the location of the cross hairs and then push any punctuation key on the keyboard instead of the carriage return (CR). The position of the cross hairs is changed by two dials (horizontal and vertical) available to the user near the terminal keyboard.

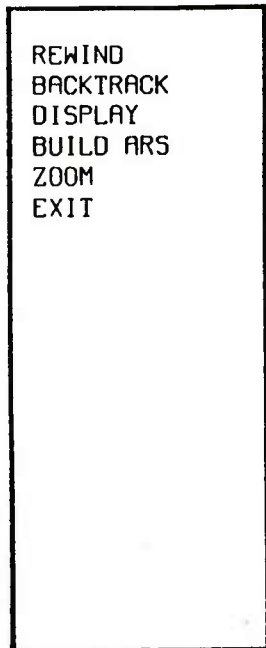

Figure 8. CADAIR MENU

The MENU lists several different procedures available to the user. The user may optionally select any procedure by merely positioning the horizontal cross hair over the name of the procedure and then pressing any punctuation key. When the procedure is completed the MENU will reappear on the screen.

The explanation of each procedure (MENU item), supplemented with illustrations, follows:

REWIND	This MENU entry permits the terminal user to rewind the entire plot file. This is a minor procedure that helps the user when previewing the various cross-cuts plots on PLOTFILE.
BACKTRACK	This MENU entry permits the user to back up the plot file (PLOTFILE) in order to preview the previous cross-sectional plot.
DISPLAY	This procedure displays the current cross-section plot in PLOTFILE on the graphics terminal. Figure 9 illustrates a typical example of a cross-sectional view of a tank turret. Successive use of this procedure allows the user to preview each cross-sectional plot in the plot file (PLOTFILE). This procedure may also be applied to plot files generated by the PICTUR option of the GIFT code if one condition is satisfied. The title card (Figure 6) used for the PICTUR run should be blank. Effectively the plot file output from PICTUR could be edited to accomplish the same thing. Figure 10 illustrates a typical perspective view of a tank which was produced by the PICTUR option of the GIFT code.

DISPLAY

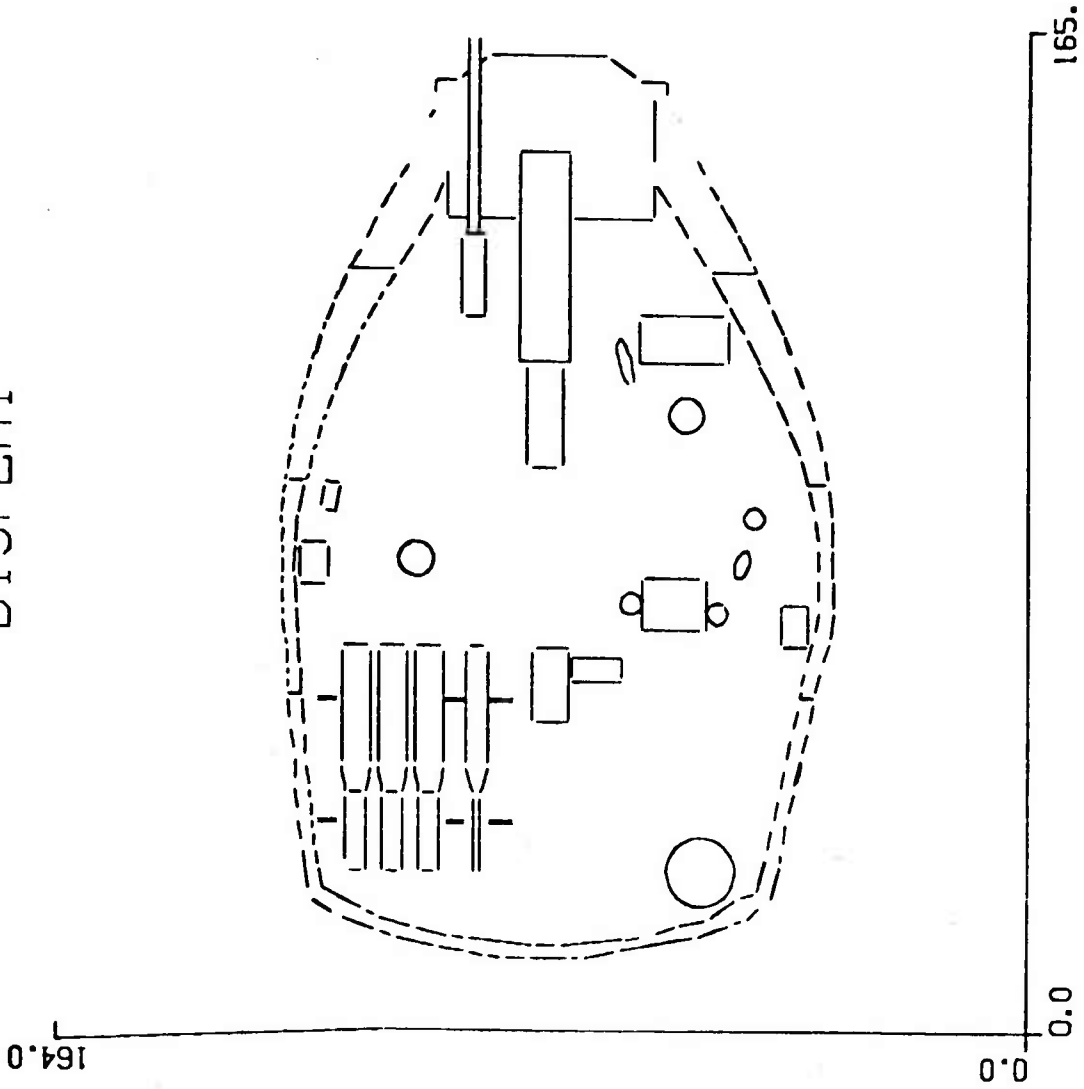

Figure 9. DISPLAY Cross-Section Example

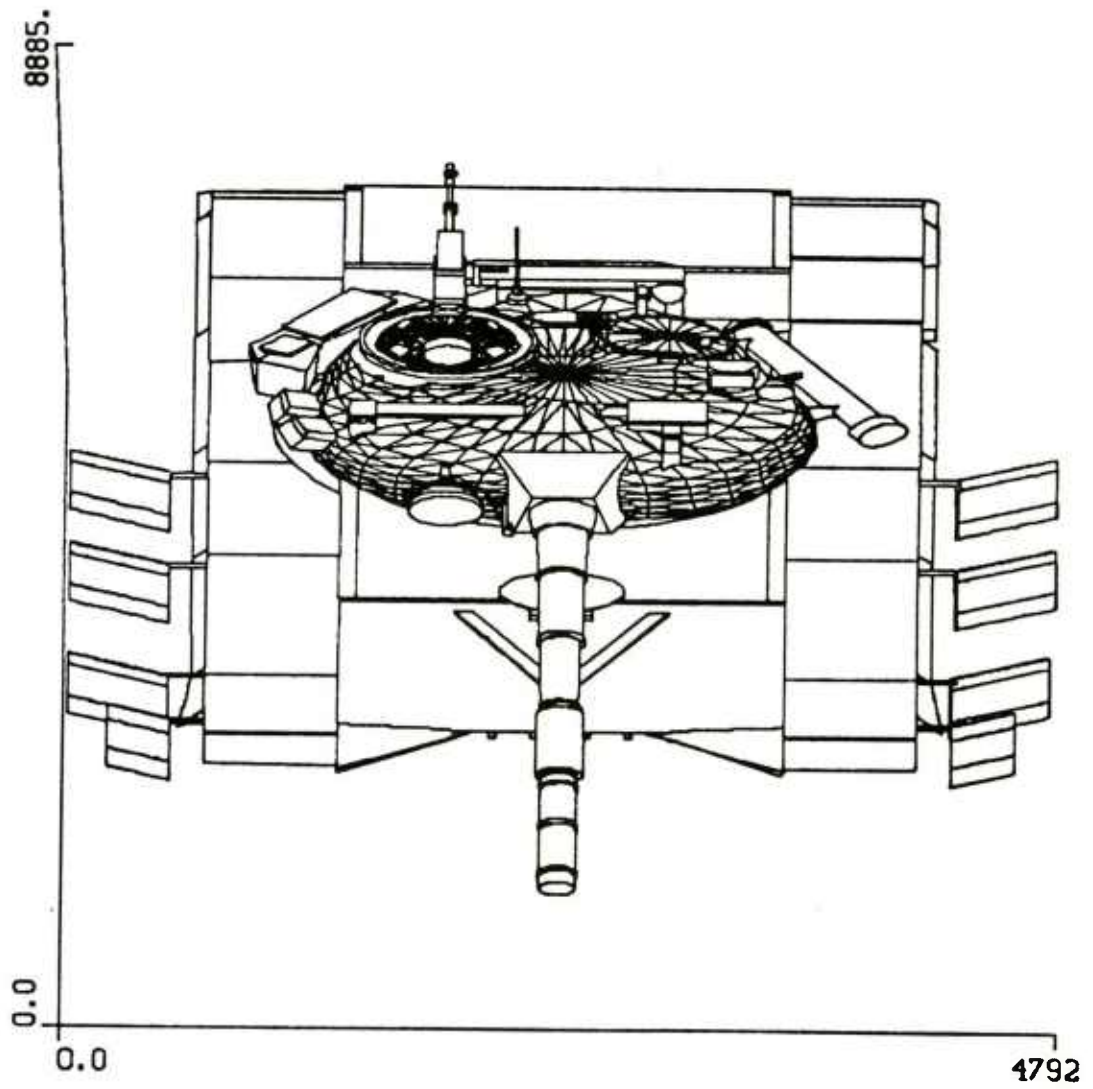

Figure 10. DISPLAY Perspective View Example

## BUILD ARS

This procedure encompasses the overall purpose of the CADAIR program. When this procedure is initiated, the plotfile is automatically rewound. Figure 11 shows the first cross section (with prompts) which is displayed for the example of the inverted tumbler. A requirement for the ARS solid is that the first and last curves degenerate around a single point. Therefore, the user is prompted by the message "SELECT FIRST ARS POINT/CURVE." The user is expected to position the terminal cross hairs so that they intersect within the shell wall boundary of the displayed cross section. The user then presses any punctuation key to send the cross hair X and Y positional information to the host computer. The program resumes by clearing the screen, displaying the same cross-section and prompting the user with the message "SELECT POINT FOR ARS CURVE." A second requirement for describing ARS solids is that all the intermediate curves (not first or last curve) be closed curves. This means that the first and last point of a curve have the same position. The user is thus free to select points that describe a curve which satisfy any arbitrary shape requirement. In the case of describing internal air, the curve would be confined to the shell surrounding the internal compartment. Figure 12 shows the example of the internal air boundary curve for the inverted tumbler. Line segments with arrowheads are displayed on the screen to aid the user while the ARS curve is being constructed. The ARS Curve point selection mode terminates automatically when the user closes the curve (i.e., the last point matches the first point). When the user closes the ARS curve, the message "END OF CURVE" is displayed on the screen. Figure 13 illustrates this for the example of the inverted tumbler. The program resumes when the user presses the carriage return (CR), key. Consideration need be directed to two further requirements for describing the ARS solid. Each curve of the ARS solid must have the same number of points. This number (not to exceed 19) is automatically set by the user depending on the number of points needed to define the first closed curve. Therefore, each subsequent curve must have the same number of points as the first curve. Additionally, the consecutive points in adjacent ARS curves should retain a "reasonable" degree of cadence or correspondence. Figure 14 illustrates the display on the screen which aids the user in dealing with the two additional ARS requirements outlined above. This display includes a "star" along with the usual cross section and related prompting messages. The star-like guide is centered at the lateral position of the first degenerate ARS curve which was user defined. Each radial arrow in the star points to the user selected points of the preceding curve of the ARS.

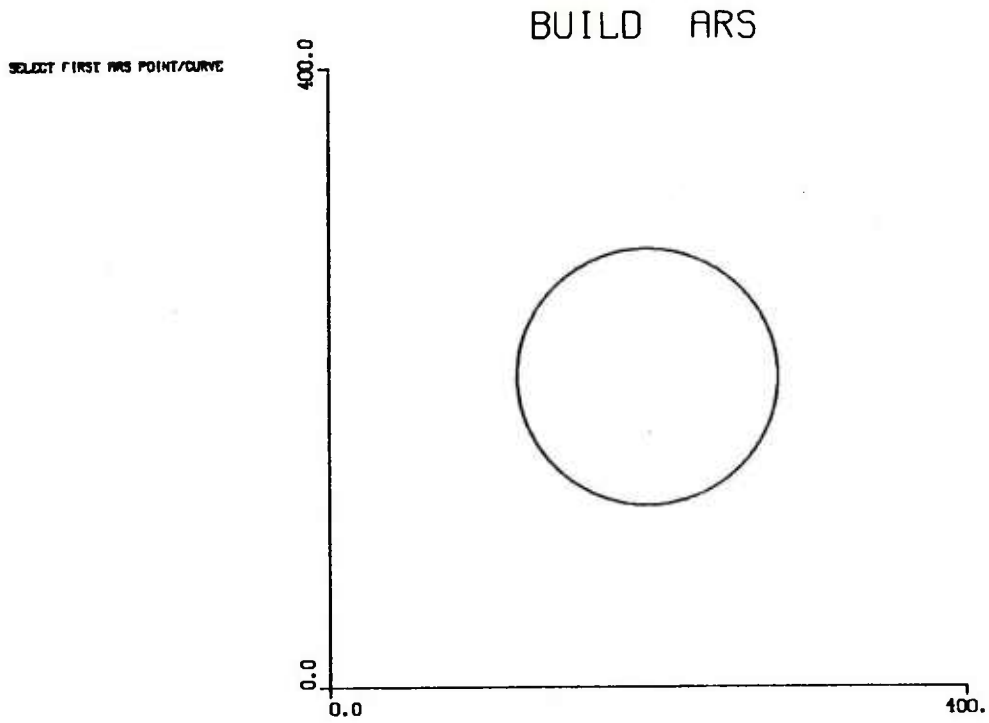

Figure 11. Inverted Tumbler - First Display

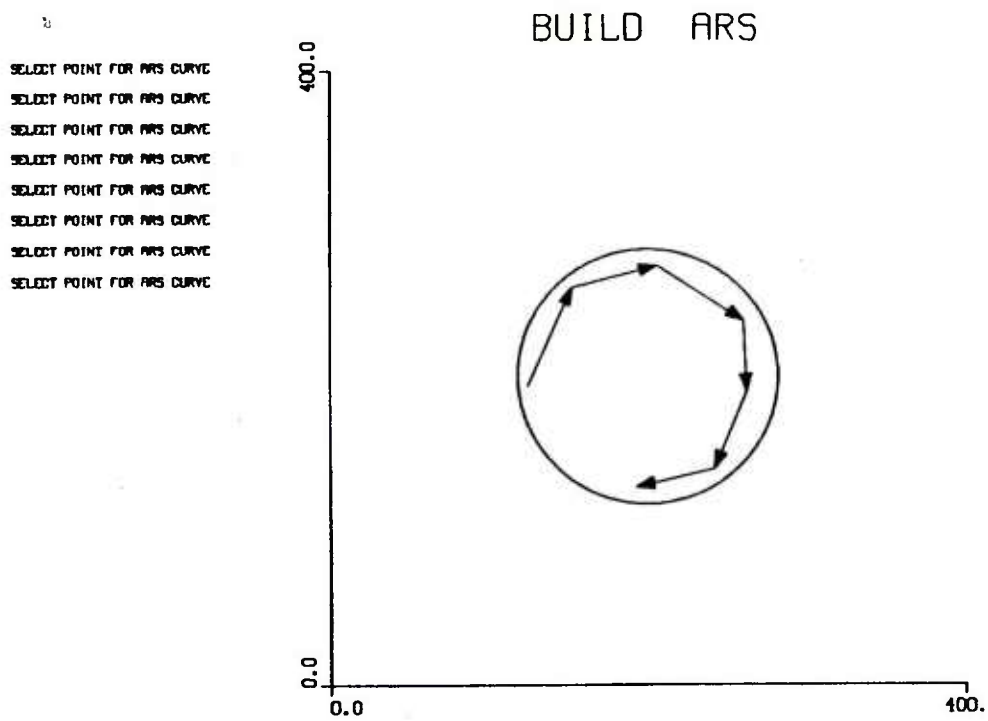

Figure 12. Inverted Tumbler - Second Display

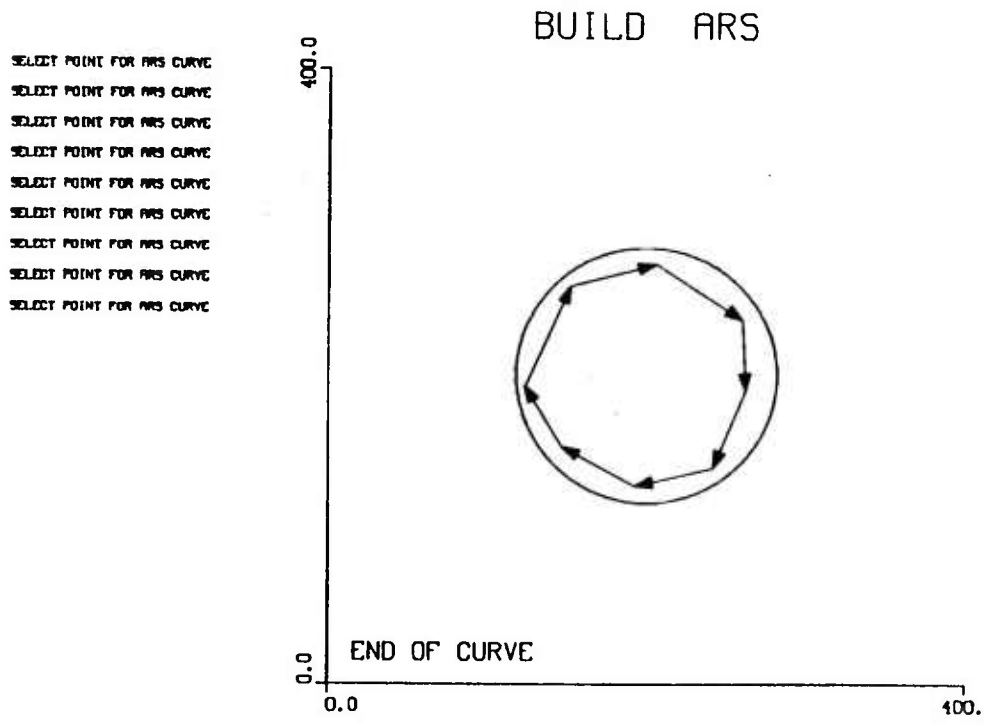

Figure 13. Inverted Tumbler - Second Display - End

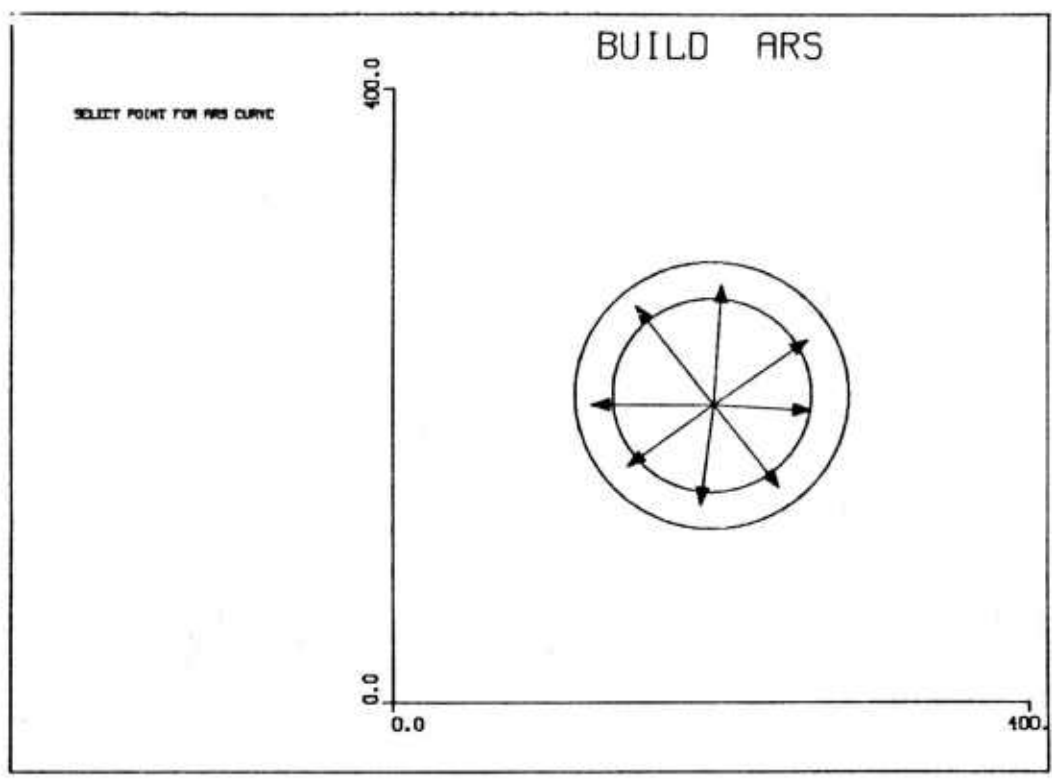

Figure 14. Inverted Tumbler - Third Display - Start

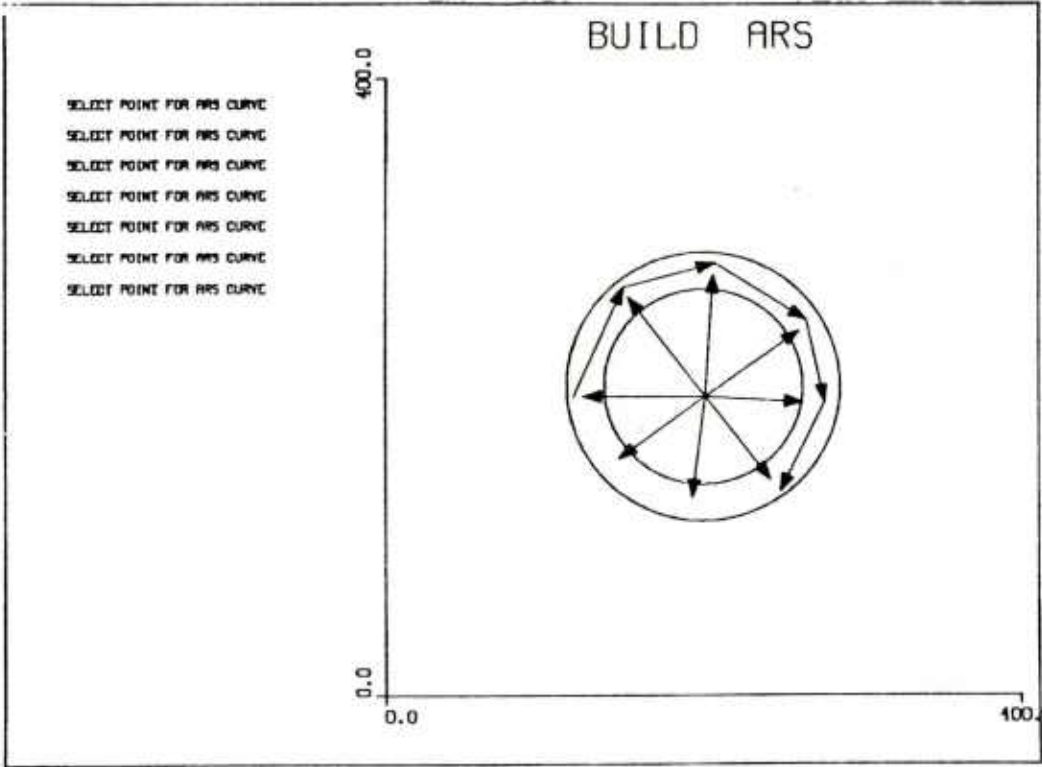

Figure 15. Inverted Tumbler - Third Display - Midway

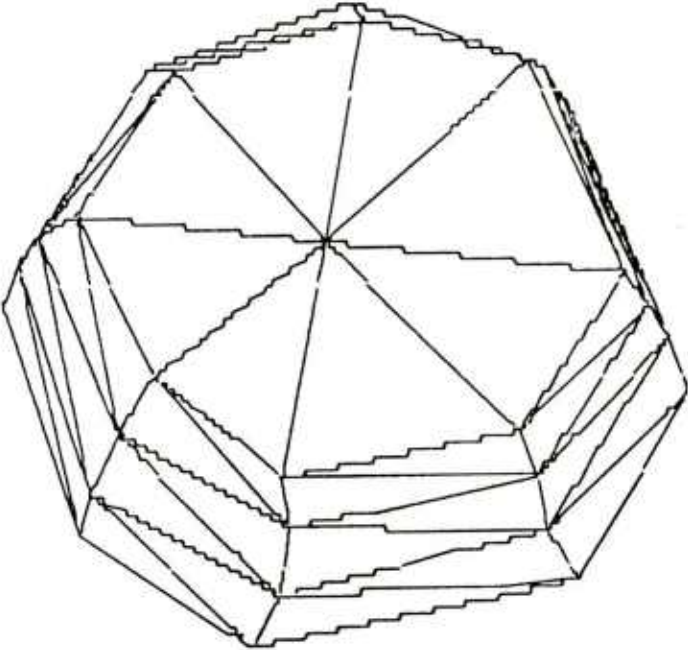

Figure 16. Perspective View of Completed ARS Solid

BUILD ARS  
(cont.)

The purposes of star guide are twofold: It helps the user to keep track of the number of points that now must be used in defining the curve, and it aids the user in selecting points in the vicinity of the same angular zone to maintain the cadence mentioned above. Figure 15 illustrates this by showing the user defined third ARS curve partially completed. When the curve is completed, the message "END OF CURVE" is displayed. The user presses the carriage return key and the process described above repeats for all of the remaining ARS curves. In order to save this file the user should enter the command SAVE,PUNCH after returning to the operating system. Figure 16 illustrates a perspective view of the ARS solid which was described in this example. To exit prematurely from this procedure, the user need only move the horizontal cross-hair below the plot axis while selecting points. The screen will be cleared and the menu displayed again.

ZOOM

This function, as the name implies, permits the user to optionally expand a small region of the displayed plot for convenient viewing. Initially the current cross-section plot in PLOTFILE is displayed on the graphics screen. Figure 17 illustrates an example with a cross-sectional view of a tank cupola. The user is required to press a punctuation key to continue this procedure. The prompting message "SELECT LOWER LEFT CORNER" instructs the user to define the lower left corner of a "window" which will later be expanded to fill up the whole plot area. The "window" definition operation is performed by the user through the usual use of the cross hairs and punctuation key. The user then responds similarly to the next prompting message "SELECT UPPER RIGHT CORNER." The user defined window area is then magnified and displayed on the graphics screen. Figure 18 illustrates the enlarged view of the window area shown in Figure 17. This procedure will also function on plot files created by PICTUR provided that the title card is modified as discussed for the DISPLAY procedure.

EXIT

This menu entry allows the user to return to the network operating system (NOS) to perform other computer operations possibly unrelated to CADAIR.

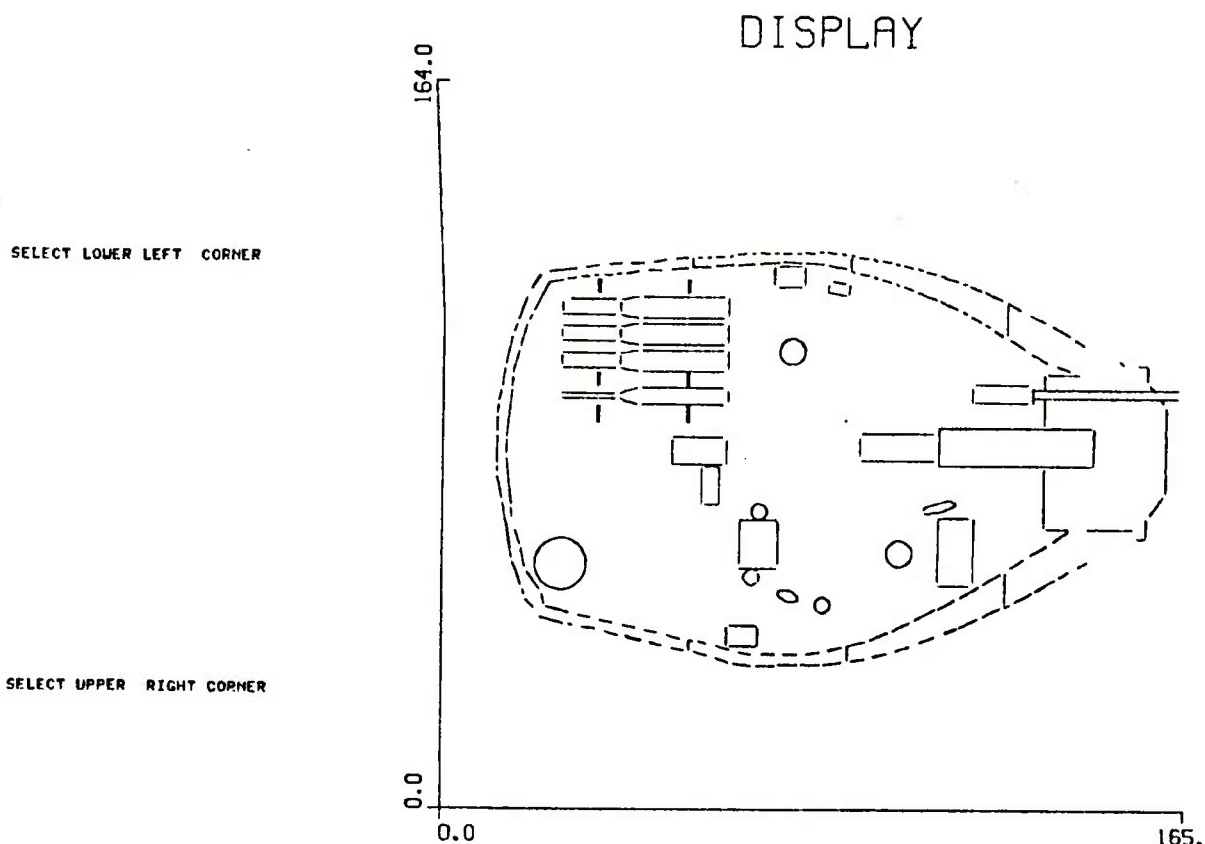

Figure 17. ZOOM Example - Start ZOOM

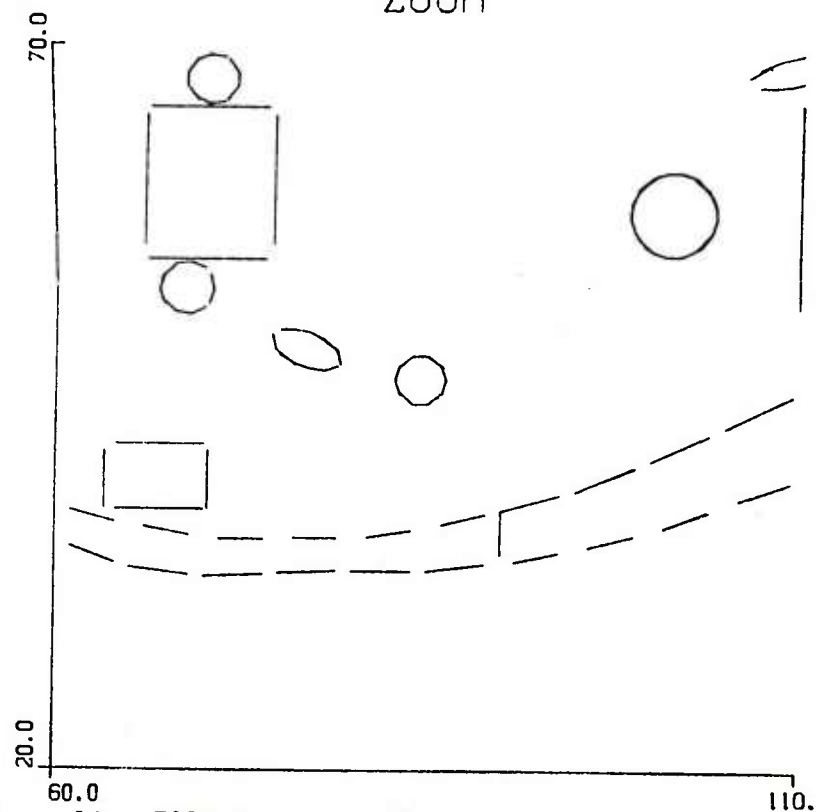

Figure 18. ZOOM Example - Result

## VI. ARS COORDINATE TRANSLATION

The ARS solid described by the preceding technique may need to undergo a coordinate translation before it is used in the COM-GEOM description. This is necessary because the XSECT option of the GIFT code changes the coordinate system of the COM-GEOM description as it creates the cross-section plot file. The amount of coordinate change depends on how the XSECT option was set up to run. Figure 19 illustrates the input required by the XSECT option which defines the boundary of the cross-section plot.

1-8	9-16	17-24	25-32	33-40	41-48	49-56	57-64	65-72	73-80
P(1)	P(2)	P(3)	P(4)	P(5)	P(6)	P(7)	P(8)	P(9)	

### FORMAT (9F8.0)

- P(1-3) - Specify the x, y, and z coordinate of the point in the upper left corner on plotter of cross section.
- P(4-6) - Specify the x, y, and z coordinate of the point in the lower left corner on plotter of cross section.
- P(7-9) - Specify the x, y, and z coordinate of the point in the lower right corner on plotter of cross section.

Figure 19. Plane Card for XSECT Option

Figure 20 shows a cross-sectional plot of a target with the parameters of Figure 19 indicated on the drawing. The coordinates of the points of the XSECT output file include no negative values. Table I summarizes the required translation of the ARS solid in order that it be compatible with the associated COM-GEOM description. Additionally, in case 2 the Y and Z coordinate values must be exchanged. In case 3 both the X and Z values and then the Y and Z coordinate values need be exchanged, respectively.

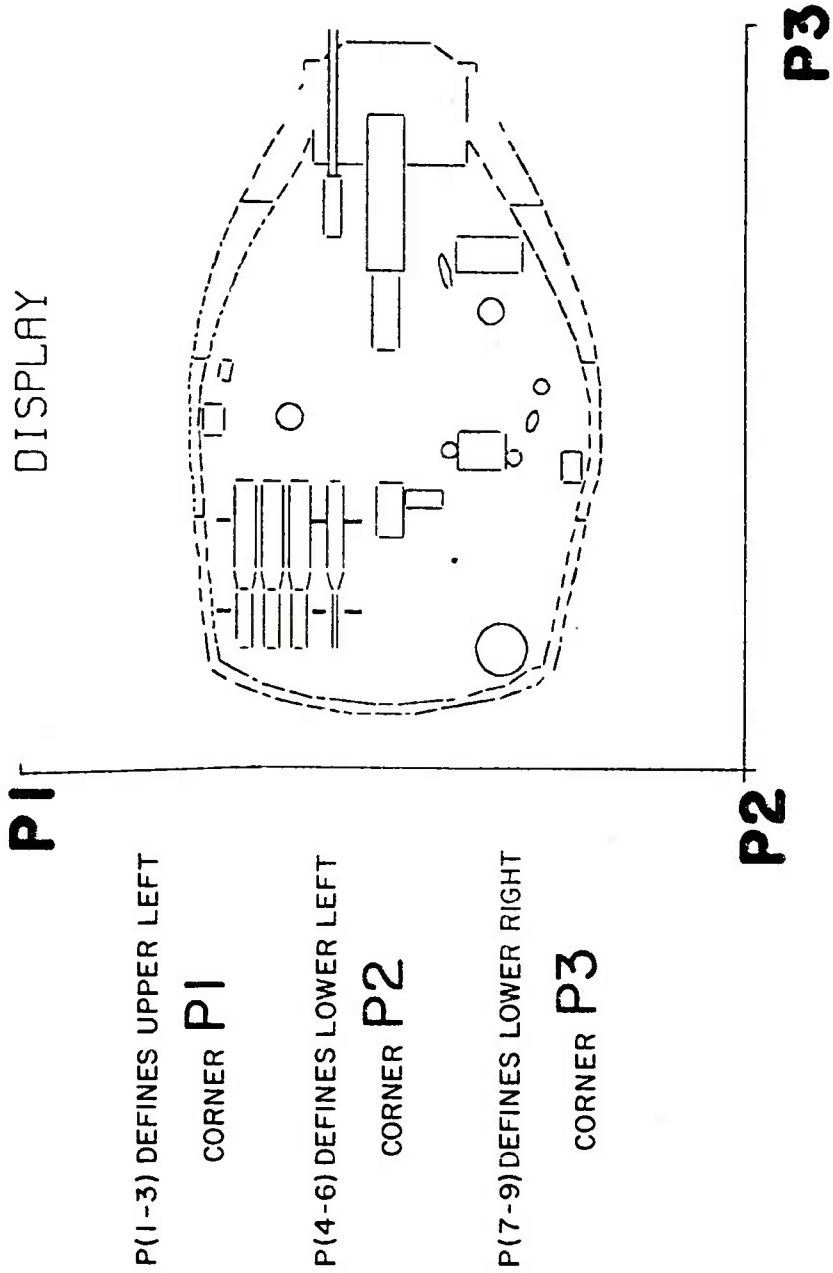

Figure 20. XSECT Plot Defined by COM-GEOM Coordinates

Table 1. Coordinate Transformation Formulae

CASE 1: Z-Plane XSECT Plots ( $P_3 = P_6 = P_9$ )

Translate ARS solid X values by minimum of  $P_1$ ,  $P_4$  or  $P_7$ .  
Translate ARS solid Y values by minimum of  $P_2$ ,  $P_5$  or  $P_8$ .

CASE 2: Y-Plane XSECT Plots ( $P_2 = P_5 = P_8$ )

Translate ARS solid X values by minimum of  $P_1$ ,  $P_4$  or  $P_7$ .  
Translate ARS solid Y values by minimum of  $P_3$ ,  $P_6$  or  $P_9$ .  
Exchange the Z and Y values of the ARS solid.

CASE 3: X-Plane XSECT Plots ( $P_1 = P_4 = P_7$ )

Translate ARS solid Y values by minimum of  $P_2$ ,  $P_5$  or  $P_8$ .  
Translate ARS solid Z values by minimum of  $P_3$ ,  $P_6$  or  $P_9$ .  
Exchange the X and Z values of the ARS solid; then exchange the Y and Z values of the ARS solid.

## VII. DISCUSSION

The preceding description of the CADAIR program was largely concerned with its single utility for describing internal air in COM-GEOM descriptions. There are, however, several other possible uses for the CADAIR program. COM-GEOM descriptions of armored vehicles are often required to include many small "boxes" (i.e., radio, control panels, etc.) that may be attached to the vehicle main armor. In the regular process of modeling these boxes, there often are problems with the boxes overlapping the armor or each other in the COM-GEOM description. The CADAIR program may be used for modeling these small boxes with simple (4 pts/curve) ARS solids. The advantage is clear for the user being able to see where the "boxes" are placed in relation to other target components to avoid overlaps. The problem of "overlaps" in COM-GEOM descriptions has incurred many delays and cost increases for doing target descriptions.

It is occasionally desired to quantitatively determine the protection afforded an armored vehicle through the addition of a ballistic liner. For the case of curved tank turrets, it can prove troublesome to modify COM-GEOM descriptions to include a liner. In these situations, advantage may be realized through the use of the CADAIR program. The XSECT output file may be simulated by other means in order to utilize the CADAIR program to construct original COM-GEOM descriptions. Figure 2 illustrates such an example for the M60A1 turret which was created through use of the CADAIR program. In this case, the tank manufacturer made available a series of drawings which showed "cross-cut" sections of the turret casting. Measurements were taken from these drawings in order to build a plot file (XSECT equivalent output file) suitable as input for the CADAIR program. Figure 21 illustrates a typical ARS curve made during this particular exercise of the CADAIR program. The ARS solids which describe the M60A1 turret exterior surface are shown in Figure 2.

# BUILD ARS

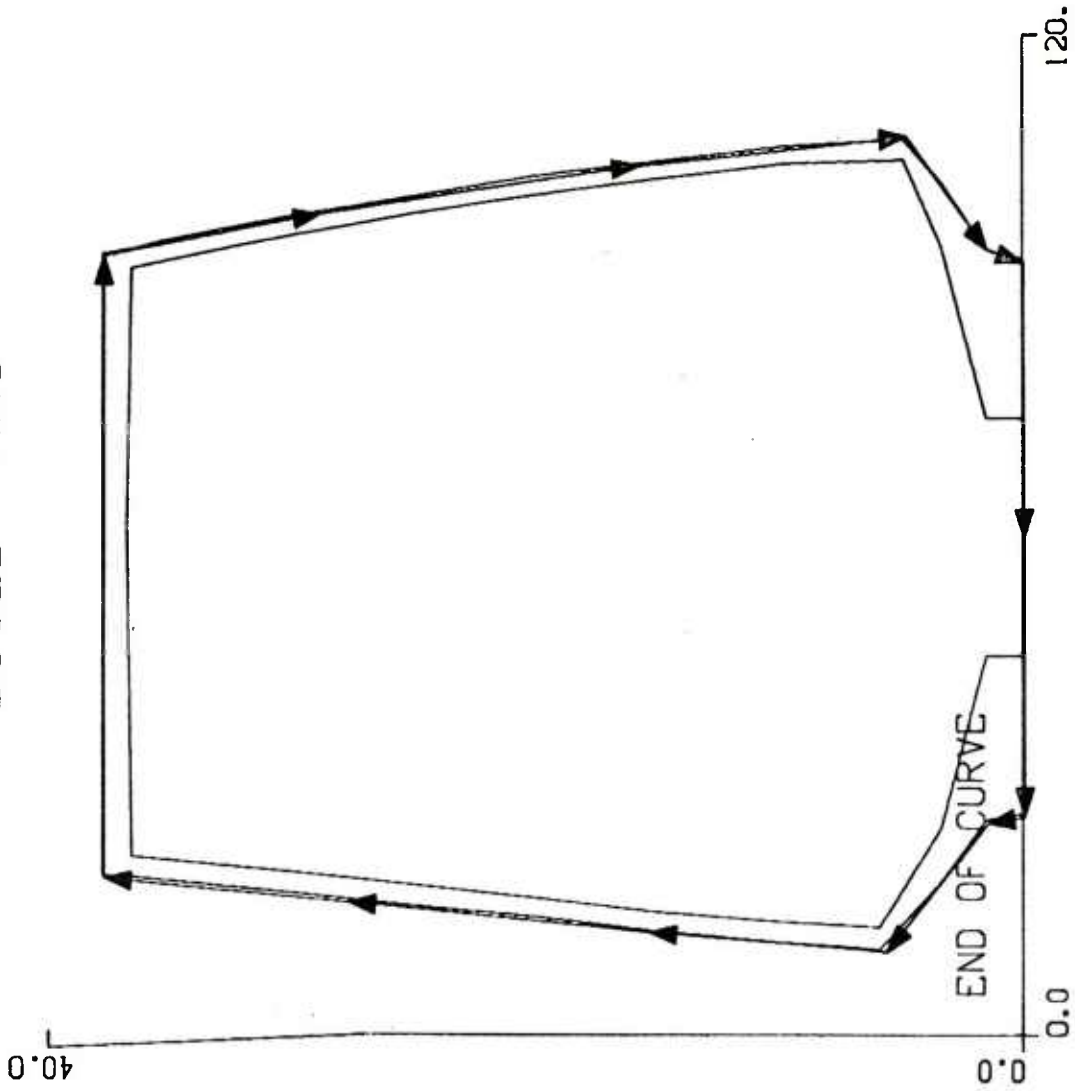

- SELECT POINT FOR ARS CURVE
- SELECT POINT FOR ARS CURVE
- SELECT POINT FOR ARS CURVE
- SELECT POINT FOR ARS CURVE
- SELECT POINT FOR ARS CURVE
- SELECT POINT FOR ARS CURVE
- SELECT POINT FOR ARS CURVE
- SELECT POINT FOR ARS CURVE
- SELECT POINT FOR ARS CURVE
- SELECT POINT FOR ARS CURVE
- SELECT POINT FOR ARS CURVE
- SELECT POINT FOR ARS CURVE
- SELECT POINT FOR ARS CURVE
- SELECT POINT FOR ARS CURVE
- SELECT POINT FOR ARS CURVE
- SELECT POINT FOR ARS CURVE

Figure 21. Turret Cross-Cut

APPENDIX A

Combinatorial Geometry Background

## Combinatorial Geometry Background

The GIFT computer code requires a combinatorial geometry (COM-GEOM) target description as input data. Familiarization with the COM-GEOM technique and terminology is required to understand the target description. The following is a brief introduction to the COM-GEOM technique of target description. Reference 1 gives a more detailed account of the COM-GEOM method as required for input to the GIFT code.

Engineering drawings, manuals, photographs or other descriptive material are required to produce a COM-GEOM description. The COM-GEOM technique utilizes twelve basic geometric solids (see Table A-1) combined under three set-theory (BOOLEAN) type operations to define the shape and location of each component of a target. A complete COM-GEOM description contains the three distinct parts: a solid table, a region table and a region identification table.

A solid is defined as one of the twelve geometric shapes available for COM-GEOM descriptions. The parameters of a solid give its location, size and orientation within the coordinate system established for the target. Each solid is uniquely numbered and its parameters listed in the solid table.

A region is the space occupied by a single solid or combination of solids. Solids are combined using the three operations: intersection (+), union (OR) and difference (-). The intersection (+) of two solids is defined as the space in common with both solids. The union (OR) of two solids is defined as the space in both of the solids. The difference (-) of two solids is defined as the space in the first solid minus the space of the second solid. Figure A-1 is a graphic illustration of these three operations. Any number of solids from the solid table may be used to define a region. Each region is uniquely numbered and its defined combination of solids is listed in the region table.

In the region identification table, each region is assigned an identification code number. These code numbers either identify each specific region as a component of the target or as an air space. Space not described as a region is assigned the air space code "01" by the GIFT code. It is not necessary to describe the inside air of a target, in which case both inside and outside air will be identified by the 01 space code. However, in many targets, it is important to distinguish between inside and outside air. For these targets, all interior space is described as a region and identified as inside air, leaving the 01 space code for outside air only. The RAYAIR subroutine of the GIFT code allows any region identified with a space code to overlap any region identified with an item code or the same space code. However, regions with different code numbers cannot overlap.

Table A-1. Geometric Solids Used in COM-GEOM Descriptions

SYMBOL	SOLID NAME
RPP	Rectangular Parallelepiped
BOX	Box
RAW	Right Angle Wedge
ARB	Arbitrary Convex Polyhedron
ARS	Triangular Surfaced Polyhedron
ELL	Ellipsoid of Revolution
SPH	Sphere
RCC	Right Circular Cylinder
REC	Right Elliptical Cylinder
TRC	Truncated Right Angle Cone
TEC	Truncated Elliptic Cone
TOR	Torus

The region identification table also allows 40 alphanumeric characteristics of descriptive data per region. The analyst needs to know the type and percentage of material making up each region. The percentage value is used to produce an equivalent line-of-sight thickness of the material type. This information is included in the 40 characters of descriptive data in the region identification table.

The three tables described above constitute a complete COM-GEOM target description as required for input to the GIFT computer code.

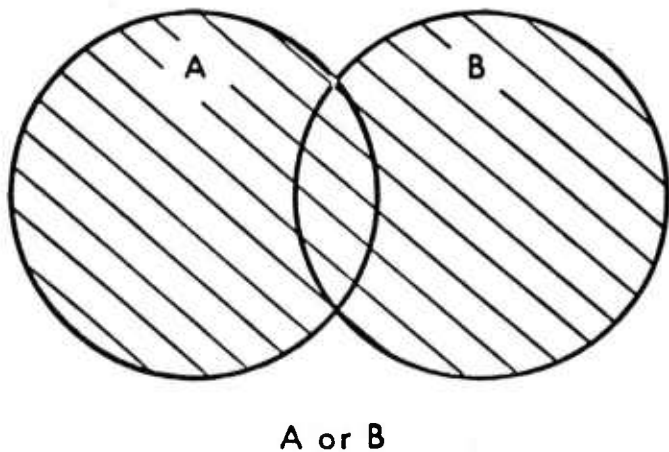
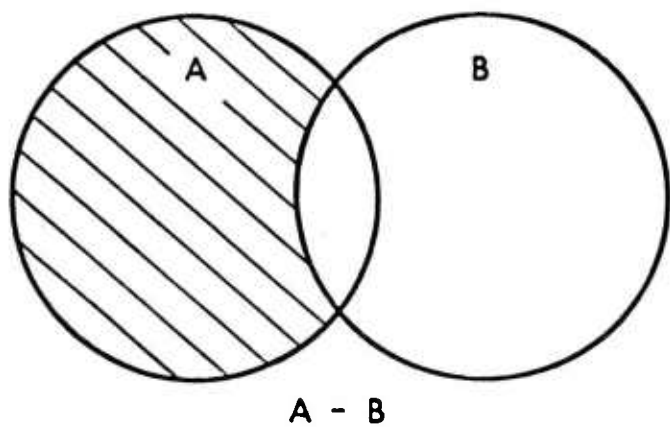
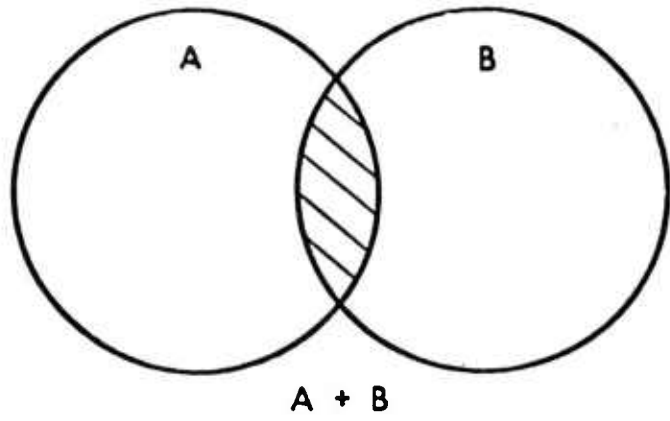

Figure A-1. Intersection (+), Subtraction (-), Union (OR) of Solids

APPENDIX B  
CADAIR Program Listing

```

PROGRAM CADAIR (INPUT,OUTPUT,PUNCH,TAPES,TAPE6=OUTPUT,TAPE7,TAPE10* 0*
I ,TAPE8=PUNCH,TAPE12)
C CADAR 2
C CADAR 3
C CADAR 4
C 'CADAIR' IS AN INTERACTIVE GRAPHICS PROGRAM WHICH AIDS THE USER CADAR 5
C IN CONSTRUCTING 'AHS' SOLIDS FOR CDM-GEDM DESCRIPTIONS. THIS CADAR 6
C VERSION OF 'CADAIR' INITIATES COMMUNICATIONS WITH THE TEKTRONICS CADAR 7
C MODEL 4010 GRAPHICS TERMINAL AT 9600 BAUD. SUBROUTINES IDENTIFIED CADAR 8
C BELOW MAKE EXTENSIVE USE OF THE 'DISPLA' LIBRARY WHICH IS THE CADAR 9
C PROPRIETARY PRODUCT OF ISSCO, INC. CADAR10
C CADAR11
C CADAR12
C *** MENU DEFINITIONS *** CADAR13
C CADAR14
C REWIND - REWIND TAPE12 (PLDTFILE) TO BEGINNING OF TAPE CADAR15
C BACKSPACE - REWIND TAPE12 (PLOTFILE) TO START OF PREVIOUS PLDT CADAR16
C DISPLAY - DISPLAY CURRENT PLDT ON GRAPHICS SCREEN CADAR17
C BUILD ARS - ASSIST USER IN CONSTRUCTING AN ARS SOLID CADAR18
C ZOOM - 'ZOOM IN' ON DISPLAYED PLOT CADAR19
C EXIT - RETURN TO OPERATING SYSTEM (NDS) CADAR20
C CADAR21
C CADAR22
C COMMON /ZAP/ ICDNT CADAR23
C ICONT=0 CADAR24
C CALL TK4010 (9600) CADAR25
C CALL SETDEV (6,6) CADAR26
C 1 CALL CLEAR CADAR27
C CALL MENU CADAR28
C CALL CURSOR (CX,CY) CADAR29
C CALL ENDGR (0) CADAR30
C CALL CLEAR CADAR31
C PRINT *, CX,CY CADAR32
C CADAR33
C CADAR34
C IF (CY.LT.686.0.AND.CY.GT.655.) CALL REDO CADAR35
C IF (CY.LT.655.0.AND.CY.GT.624.) CALL BACKUP CADAR36
C IF (CY.LT.624.0.AND.CY.GT.593.) CALL PICT CADAR37
C IF (CY.LT.593.0.AND.CY.GT.562.) CALL DRAW CADAR38
C IF (CY.LT.562.0.AND.CY.GT.531.) CALL ZOOM CADAR39
C IF (CY.LT.531.0.AND.CY.GT.500.) CALL OUT CADAR40
C CADAR41
C GO TO I CADAR42
C END CADAR43
C SUBROUTINE CLEAR * 43*
C CLEAR 2
C SUBROUTINE CLEAR ERASES THE GRAPHICS SCREEN CLEAR 3
C CLEAR 4
C IRACE=000740354033401400008 CLEAR 5
C CALL CONNOC (10) CLEAR 6
C WRITE (10) IRACE CLEAR 7
C CALL DISCON (10) CLEAR 8
C RETURN CLEAR 9
C END CLEAR10
C SUBROUTINE MENU * 53*
C MENU 2
C SURROUTINE MENU DISPLAYS THE MENU PROCEDURES ON THE SCREEN MENU 3
C MENU 4
C CALL PAGE (8.1315,6.2) MENU 5
C CALL PHYSOR (0.63,0.59) MENU 6
C CALL TITLE (' ',1,' ',0,' ',0.2,0.5.2) MENU 7
C CALL FRAME MENU 8
C CALL MESSAG ('REWIND',6,0.2,4.75) MENU 9
C CALL MESSAG ('BACKTRACK',9,0.2,4.5) MENU 10

```

CALL MESSAG ('DISPLAY',7,0.2,4.25)	MENU 11
CALL MESSAG ('BUILO ARS',9,0.2,4.0)	MENU 12
CALL MESSAG ('ZOOM',4,0.2,3.75)	MENU 13
CALL MESSAG ('EXIT',4,0.2,3.5)	MENU 14
RETURN	MENU 15
ENO	MENU 16
SUBROUTINE CURSOR (CX,CY)	* 69*
C	CURSR 2
C SUBROUTINE CURSOR TURNS ON THE TERMINAL CROSS-HAIRS AND FACILITATES	CURSR 3
C ( USER SELECTED ) SCREEN COORDINATE DATA TRANSFER TO THE HOST	CURSR 4
C COMPUTER	CURSR 5
C	CURSR 6
DIMENSION IHY(2)	CURSR 7
ITRAN=00060012001500000000B	CURSR 8
ITURN=00074035403340320000B	CURSR 9
MHX=00000000003700000000B	CURSR10
MLX=000000000000000370000B	CURSR11
MHY=000000000000000000037B	CURSR12
MLY=003700000000000000000B	CURSR13
CALL TSENS	CURSR14
CALL CONNEC (10)	CURSR15
WRITE (10) ITRAN,ITURN	CURSR16
BUFFER IN( 10,1)(IHY(1),IHY(2))	CURSR17
CALL DISCON (10)	CURSR18
JHX=ANO(IHY(1),MHX)	CURSR19
JLX=AND(IHY(1),MLX)	CURSR20
JHY=ANO(IHY(1),MHY)	CURSR21
JLY=ANO(IHY(2),MLY)	CURSR22
KHX=SHIFT(JHX,-19)	CURSR23
KLX=SHIFT(JLX,-12)	CURSR24
KHY=SHIFT(JHY,5)	CURSR25
KLY=SHIFT(JLY,-48)	CURSR26
LX=OR(KHX,KLX)	CURSR27
LY=OR(KHY,KLY)	CURSR28
CX=FLOAT(LX)	CURSR29
CY=FLOAT(LY)	CURSR30
RETURN	CURSR31
ENO	CURSR32
SUBROUTINE RE00	* 101*
C	RE00 2
C SUBROUTINE RE00 INITIATES THE PROCEOURE FOR THE MENU ENTRY	RE00 3
C 'REWINO'	RE00 4
C	RE00 5
COMMON /ZAP/ ICONT	RE00 6
C REWINO GRAPHICS FILE ATTACHEO TO TAPE12	RE00 7
REWINO 12	RE00 8
ICONT=0	RE00 9
RETURN	RE00 10
ENO	RE00 11
SUBROUTINE BACKUP	* 112*
C	BACKP 2
C SUBROUTINE BACKUP INITIATES THE PROCEDURE FOR THE MENU ENTRY	BACKP 3
C 'BACKSPACE'	BACKP 4
C	BACKP 5
COMMON /ZAP/ ICONT	BACKP 6
C BACKUP THE GRAPHICS FILE TO BEGINNING OF PREVIOUS PLOT	BACKP 7
IF (ICONT.EQ.0) RETURN	BACKP 8
REWINO 12	BACKP 9
ICONT=ICONT-1	BACKP10
CALL SKIPFE (12,ICONT,0)	BACKP11
RETURN	BACKP12
ENO	BACKP13
SUBROUTINE PICT	* 125*
C	PICT 2
C SUBROUTINE PICT INITIATES THE PROCEOURE FOR THE MENU ENTRY	PICT 3
C 'DISPLAY'	PICT 4

C	DIMENSION X(300), Y(300), FIL(999)	PICT 5
	COMMON /ZAP/ ICONT	PICT 6
	COMMON /ZIP/ ZZ(30), HOR, VET, NC	PICT 7
	COMMON /ZOP/ HAR, VAT	PICT 8
	IF (ICONT.EQ.0) IEND=100	PICT 9
	IF (ICONT.GE.IEND) REWIND 12	PICT 10
	IF (ICONT.GE.IEND) RETURN	PICT 11
1	READ (12,7) NC, (ZZ(I), I=1, NC)	PICT 12
	IF (EOF(I2)) 1,2	PICT 13
2	IF (NC.EQ.1) READ (12,8) A,B,HOR,VET	PICT 14
	IF (NC.NE.1) READ (12,8) A,B,C,HOR,VET	PICT 15
	CALL PHYSOR (3.0,0.59)	PICT 16
	CALL TITLE (' DISPLAY ',10,' ',1,' ',1,5.0,5.0)	PICT 17
	CALL GRAF (0.0,HOR,HOR,0.0,VET,VET)	PICT 18
3	READ (12,9) N	PICT 19
	IF (N.EQ.1) READ (12,5) HO,VE	PICT 20
	IF (N.EQ.1) GO TO 3	PICT 21
	IF (N.EQ.-2) READ (12,6) NF	PICT 22
	IF (N.EQ.-2) READ (12,5) (FIL(IJ), IJ=1, NF)	PICT 23
	IF (N.EQ.-2) GO TO 3	PICT 24
	IF (N.EQ.0) GO TO 4	PICT 25
	READ (12,10) (X(I), Y(I), I=1, N)	PICT 26
	CALL CURVE (X, Y, N, 0)	PICT 27
	GO TO 3	PICT 28
4	CONTINUE	PICT 29
	CALL CURSOR (CX, CY)	PICT 30
	CALL ENDGR (0)	PICT 31
	CALL RESET ('PHYSOR')	PICT 32
	ICONT=ICONT+1	PICT 33
	HAR=HOR	PICT 34
	VAT=VET	PICT 35
	IEND=NC	PICT 36
	RETURN	PICT 37
C		PICT 38
	5 FORMAT (2F12.4)	PICT 39
	6 FORMAT (1110)	PICT 40
	7 FORMAT (15,20F5.1)	PICT 41
	8 FORMAT (6F12.4)	PICT 42
	9 FORMAT (1110)	PICT 43
	10 FORMAT (6F12.4)	PICT 44
	ENO	PICT 45
	SUBROUTINE DRAW	PICT 46
		* 171*
C		DRAW 2
C	SUBROUTINE DRAW INITIATES THE PROCEDURE FOR THE ENTRY	DRAW 3
C	'BUILD ARS'	DRAW 4
C		DRAW 5
	DIMENSION X(30,30), Y(30,30), Z(30,30), XC(2), YC(2)	DRAW 6
	COMMON /ZAP/ ICONT	DRAW 7
	COMMON /ZIP/ ZZ(30), HOR, VET, NC	DRAW 8
	CALL REOO	DRAW 9
	AXS=365.0SAYS=63.0	DRAW 10
	CALL CLEAR	DRAW 11
	CALL PACT	DRAW 12
	IF (NC.EQ.1) CALL ENDPL (0)	DRAW 13
	IF (NC.EQ.1) RETURN	DRAW 14
	CALL HEIGHT (.07)	DRAW 15
	CALL MESSAG ('SELECT FIRST ARS POINT/CURVES',100,-2.5,5.0)	DRAW 16
	CALL RESET ('HEIGHT')	DRAW 17
	CALL CURSOR (CX, CY)	DRAW 18
	IF (CX.LT.AXS.OR.CY.LT.AYS) CALL ENDPL (0)	DRAW 19
	IF (CX.LT.AXS.OR.CY.LT.AYS) RETURN	DRAW 20
	CX=(CX-(1024.0*3.0/8.1315))*HOR/(1024.0*5.0/8.1315)	DRAW 21
	CY=(CY-(780.0*0.59/6.2))*VET/(780.0*5.0/6.2)	DRAW 22
	CALL ENOGR (0)	DRAW 23
	DO 1 I=1,30	DRAW 24

X(I,1)=CX\$Y(I,1)=CY\$Z(I,1)=ZZ(1)	DRAW 25
1 CONTINUE	DRAW 26
CALL REDO	DRAW 27
CALL CLEAR	DRAW 28
CALL PACT	DRAW 29
I=0\$FLG=0.0\$XC(1)=0.0	DRAW 30
2 CALL HEIGHT (.07)	DRAW 31
YPOS=5.0-.25*FLOAT(I)	DRAW 32
CALL MESSAG ('SELECT POINT FOR ARS CURVES',100,-2.5,YPOS)	DRAW 33
CALL RESET ('HEIGHT')	DRAW 34
I=I+1	DRAW 35
CALL CURSOR (CX,CY)	DRAW 36
IF (I.EQ.1) BX=CX	DRAW 37
IF (I.EQ.1) BY=CY	DRAW 38
DEL=SQRT((BX-CX)**2)+ABS((BY-CY)**2)	DRAW 39
IF (I.EQ.1) DEL=10.0	DRAW 40
IF (DEL.LT.9.0) FLG=1.0	DRAW 41
X(I,2)=(CX-(1024.0*3.0/8.1315))*HOR/(1024.0*5.0/8.1315)	DRAW 42
Y(I,2)=(CY-(780.0*0.59/6.2))*VET/(780.0*5.0/6.2)	DRAW 43
IF (CX.LT.AXS.OR.CY.LT.AYS) CALL ENDPL (0)	DRAW 44
IF (CX.LT.AXS.OR.CY.LT.AYS) RETURN	DRAW 45
Z(I,2)=ZZ(1)	DRAW 46
A=XC(1)	DRAW 47
IF (A.EQ.0.0) XC(1)=X(I,2)	DRAW 48
IF (A.EQ.0.0) YC(1)=Y(I,2)	DRAW 49
IF (A.EQ.0.0) GO TO 2	DRAW 50
XC(2)=X(I,2)	DRAW 51
YC(2)=Y(I,2)	DRAW 52
CALL RLVEC (XC(1),YC(1),XC(2),YC(2),1201)	DRAW 53
XC(1)=XC(2)	DRAW 54
YC(1)=YC(2)	DRAW 55
IF (I.GT.19) CALL MESSAG (16HTOO MANY POINTS\$,100,.2,.2)	DRAW 56
IF (I.GT.19) CALL ENDGR (0)	DRAW 57
IF (I.GT.19) CALL CURSOR (CX,CY)	DRAW 58
IF (I.GT.19) RETURN	DRAW 59
IF (FLG.EQ.0.0) GO TO 2	DRAW 60
CALL MESSAG ('END OF CURVES',100,.2,.2)	DRAW 61
CALL ENDPL (0)	DRAW 62
NP=1	DRAW 63
N=2	DRAW 64
X(NP,2)=X(1,2)\$Y(NP,2)=Y(1,2)	DRAW 65
LIM=NC+1	DRAW 66
3 CONTINUE	DRAW 67
N=N+1	DRAW 68
CALL CLEAR	DRAW 69
CALL PACT	DRAW 70
XC(1)=0.0	DRAW 71
NZ=NP-1	DRAW 72
L=N-1	DRAW 73
DO 4 K=1,NZ	DRAW 74
CALL RLVEC (X(1,1),Y(1,1),X(K,L),Y(K,L),1201)	DRAW 75
4 CONTINUE	DRAW 76
NPP=NP-1	DRAW 77
DO 5 J=1,NPP	DRAW 78
CALL HEIGHT (.07)	DRAW 79
YPOS=5.0-.25*FLOAT(J)	DRAW 80
CALL MESSAG ('SELECT POINT FOR ARS CURVES',100,-2.5,YPOS)	DRAW 81
CALL RESET ('HEIGHT')	DRAW 82
CALL CURSOR (CX,CY)	DRAW 83
X(J,N)=(CX-(1024.0*3.0/8.1315))*HOR/(1024.0*5.0/8.1315)	DRAW 84
Y(J,N)=(CY-(780.0*0.59/6.2))*VET/(780.0*5.0/6.2)	DRAW 85
IF (CX.LT.AXS.OR.CY.LT.AYS) CALL ENDPL (0)	DRAW 86
IF (CX.LT.AXS.OR.CY.LT.AYS) RETURN	DRAW 87
NNN=N-1	DRAW 88
Z(J,N)=ZZ(NNN)	DRAW 89
A=XC(1)	DRAW 90

IF (A.EQ.0.0) XC(1)=X(J,N)	DRAW 91
IF (A.EQ.0.0) YC(1)=Y(J,N)	DRAW 92
IF (A.EQ.0.0) GO TO 5	DRAW 93
XC(2)=X(J,N)	DRAW 94
YC(2)=Y(J,N)	DRAW 95
CALL RLVEC (XC(1),YC(1),XC(2),YC(2),1201)	DRAW 96
XC(1)=XC(2)	DRAW 97
YC(1)=YC(2)	DRAW 98
5 CONTINUE	DRAW 99
X(NP,N)=X(1,N)	DRAW100
Y(NP,N)=Y(1,N)	DRAW101
Z(NP,N)=Z(1,N)	DRAW102
IF (N.LT.LIM) CALL MESSAG (13HEND OF CURVES,100,.2,.2)	DRAW103
IF (N.LT.LIM) CALL ENDPL (0)	DRAW104
IF (N.LT.LIM) GO TO 3	DRAW105
CALL MESSAG ('END OF CURVES',100,.2,.2)	DRAW106
CALL ENDPL (0)	DRAW107
NT=NC+2	DRAW108
DO 6 I=1,NP	DRAW109
X(I,NT)=X(I,1)	DRAW110
Y(I,NT)=Y(I,1)	DRAW111
Z(I,NT)=Z(I,NC)	DRAW112
6 CONTINUE	DRAW113
PUNCH (8,8) NT,NP	DRAW114
DO 7 N=1,NT	DRAW115
PUNCH (8,9) (X(I,N),Y(I,N),Z(I,N),X(I+1,N),Y(I+1,N),Z(I+1,N),I=1,	DRAW116
1 NP,2)	DRAW117
7 CONTINUE	DRAW118
RETURN	DRAW119
C	DRAW120
8 FORMAT (3X,3HARS,4X,2I10)	DRAW121
9 FORMAT (10X,6F10.4)	DRAW122
END	DRAW123
SUBROUTINE ZOOM	* 294*
C	ZOOM 2
C SUBROUTINE ZOOM ENLARGES A USER SELECTED AREA OF THE DIS-	ZOOM 3
C PLAYED PLOT	ZOOM 4
C	ZOOM 5
DIMENSION X(300), Y(300), FIL(999), ID1(3), ID2(3)	ZOOM 6
COMMON /ZAP/ ICONT	ZOOM 7
COMMON /ZOP/ HAR, VAT	ZOOM 8
DATA ID1 /10HSELECT LOW, 10HER LEFT C, 10HORNER /	ZOOM 9
DATA ID2 /10HSELECT UPP, 10HER RIGHT, 10HCORNER /	ZOOM 10
CALL BACKUP	ZOOM 11
CALL PICT	ZOOM 12
C	ZOOM 13
HOR=HAR	ZOOM 14
VET=VAT	ZOOM 15
CALL BACKUP	ZOOM 16
PRINT *, ID1	ZOOM 17
PRINT *, ID1	ZOOM 18
CALL CURSOR (CX,CY)	ZOOM 19
CX=(CX-(1024.0*3.0/8.1315))*HOR/(1024.0*5.0/8.1315)	ZOOM 20
CY=(CY-(780.0*.59/6.2))*VET/(780.0*5.0/6.2)	ZOOM 21
XLL=CX\$YLL=CY	ZOOM 22
PRINT *, ID2	ZOOM 23
PRINT *, ID2	ZOOM 24
CALL CURSOR (CX,CY)	ZOOM 25
CX=(CX-(1024.0*3.0/8.1315))*HOR/(1024.0*5.0/8.1315)	ZOOM 26
CY=(CY-(780.0*.59/6.2))*VET/(780.0*5.0/6.2)	ZOOM 27
XUR=CX\$YUR=CY	ZOOM 28
IF (XLL.GT.CX) XUR=XLL	ZOOM 29
IF (XLL.GT.CX) XLL=CX	ZOOM 30
IF (YLL.GT.CY) YUR=YLL	ZOOM 31
IF (YLL.GT.CY) YLL=CY	ZOOM 32
XOR=XLL\$YOR=YLL	ZOOM 33

HOR=XUR-XLL\$VET=YUR-YLL	ZOOM 34
CALL CLEAR	ZOOM 35
CALL PHYSOR (3.0,0.59)	ZOOM 36
CALL TITLE (' ZOOM ',10,' ',1,' ',1,5.0,5.0)	ZOOM 37
XNEW=AMAX1(HOR,VET)	ZOOM 38
XNEW=10.0*FLOAT(IFIX(XNEW/10.0)+1)	ZOOM 39
HOR=XNEW	ZOOM 40
VET=XNEW	ZOOM 41
XOR=10.0*FLOAT(IFIX(XOR/10.0))	ZOOM 42
YOR=10.0*FLOAT(IFIX(YOR/10.0))	ZOOM 43
XUR=XOR+HOR	ZOOM 44
YUR=YOR+VET	ZOOM 45
CALL GRAF (XOR,HOR,XUR,YOR,VET,YUR)	ZOOM 46
1 READ (12,7) IOENT	ZOOM 47
IF (EOF(12)) 1,2	ZOOM 48
2 READ (12,8) A,B,C,HOR,VET	ZOOM 49
3 READ (12,9) N	ZOOM 50
IF (N.EQ.1) REAO (12,6) HO,VE	ZOOM 51
IF (N.EQ.1) GO TO 3	ZOOM 52
IF (N.EQ.-2) REAO (12,9) NF	ZOOM 53
IF (N.EQ.-2) READ (12,6) (FIL(IJ),IJ=1,NF)	ZOOM 54
IF (N.EQ.-2) GO TO 3	ZOOM 55
IF (N.EQ.0) GO TO 5	ZOOM 56
REAO (12,10) (X(I),Y(I),I=1,N)	ZOOM 57
IND=1	ZOOM 58
OO & I=1,N	ZOOM 59
IF (X(I).LT.XOR.OR.X(I).GT.XUR) GO TO 4	ZOOM 60
IF (Y(I).LT.YOR.OR.Y(I).GT.YUR) GO TO 4	ZOOM 61
X(IND)=X(I)\$Y(IND)=Y(I)	ZOOM 62
IND=IND+1	ZOOM 63
4 CONTINUE	ZOOM 64
N=IND-1	ZOOM 65
IF (N.LT.2) GO TO 3	ZOOM 66
CALL CURVE (X,Y,N,0)	ZOOM 67
GO TO 3	ZOOM 68
5 CONTINUE	ZOOM 69
CALL CURSOR (CX,CY)	ZOOM 70
CALL ENOGR (0)	ZOOM 71
CALL RESET ('PHYSOR')	ZOOM 72
ICONT=ICONT+1	ZOOM 73
RETURN	ZOOM 74
C	ZOOM 75
C	ZOOM 76
6 FORMAT (2F12.4)	ZOOM 77
7 FORMAT (8A10)	ZOOM 78
8 FORMAT (6F12.4)	ZOOM 79
9 FORMAT (1I10)	ZOOM 80
10 FORMAT (6F12.4)	ZOOM 81
END	ZOOM 82
SUBROUTINE OUT	* 376*
C RETURN TO CYBER OPERATING SYSTEM	OUT 2
CALL CLEAR	OUT 3
STOP	OUT 4
ENO	OUT 5
SUBROUTINE PACT	* 381*1
0 DIMENSION X(300), Y(300), FIL(999)	PACT 2
COMMON /ZAP/ ICONT	PACT 3
COMMON /ZIP/ ZZ(30), HOR, VET, NC	PACT 4
1 READ (12,5) NC,(ZZ(I),I=1,NC)	PACT 5
IF (EOF(12)) 1,2	PACT 6
2 READ (12,6) A,B,C,HOR,VET	PACT 7
CALL PHYSOR (3.0,0.59)	PACT 8
CALL TITLE ('BUILD ARS',10,' ',1,' ',1,5.0,5.0)	PACT 9
CALL GRAF (0.0,HOR,HOR,0.0,VET,VET)	PACT 10
3 REAO (12,7) N	PACT 11
IF (N.EQ.0) GO TO 4	PACT 12

READ (12,8) (X(I),Y(I),I=1,N)	PACT 13
CALL CURVE (X,Y,N,0)	PACT 14
GO TO 3	PACT 15
4 CONTINUE	PACT 16
ICONT=ICONT+1	PACT 17
RETURN	PACT 18
C	PACT 19
5 FORMAT (I5,15F5.1)	PACT 20
6 FORMAT (6F12.4)	PACT 21
7 FORMAT (1I10)	PACT 22
8 FORMAT (6F12.4)	PACT 23
END	PACT 24
16.07.37.UCLP, FATM1402C,	
0.586KLNS.	

DISTRIBUTION LIST

<u>No. of Copies</u>	<u>Organization</u>	<u>No. of Copies</u>	<u>Organization</u>
12	Commander Defense Technical Info Center ATTN: DTIC-DDA Cameron Station Alexandria, VA 22314	1	Commander US Army Aviation Research and Development Command ATTN: DRDAV-E 4300 Goodfellow Blvd St. Louis, MO 63120
1	HQDA ATTN: DAMA-WSW Washington, DC 20310	1	Director US Army Air Mobility Research and Development Laboratory Ames Research Center Moffett Field, CA 94035
3	Commander US Army Materiel Development and Readiness Command ATTN: DRCDMD-ST DRCLDC DRCDE-DW 5001 Eisenhower Avenue Alexandria, VA 22333	1	Commander US Army Communications Rsch and Development Command ATTN: DRSEL-ATDD Fort Monmouth, NJ 07703
4	Commander US Army Armament Research and Development Command ATTN: DRDAR-TDC (Dr. Gyrogog) DRDAR-TSS (2 cys) DRDAR-LC Dover, NJ 07801	1	Commander US Army Electronics Research and Development Command Technical Support Activity ATTN: DELSD-L Fort Monmouth, NJ 07703
1	Commander US Army Armament Materiel Readiness Command ATTN: DRSAR-LEP-L Rock Island, IL 61299	2	Commander US Army Missile Command ATTN: DRSMI-R DRSMI-YDL Redstone Arsenal, AL 35898
1	Director US Army Armament Research and Development Command Benet Weapons Laboratory ATTN: DRDAR-LCB-TL Watervliet, NY 12189	1	Commander US Army Mobility Equipment Research & Development Command ATTN: DRDME-WC Fort Belvoir, VA 22060
		1	Commander US Army TSARCOM 4300 Goodfellow Blvd St. Louis, MO 63120

DISTRIBUTION LIST

<u>No. of Copies</u>	<u>Organization</u>	<u>No. of Copies</u>	<u>Organization</u>
2	Commander US Army Tank Automotive Cmd ATTN: DRSTA-CG DRSTA-TSL Warren, MI 48090	1	Commander US Army Foreign Science & Technology Center ATTN: DRXST-MC-3 220 Seventh Street, NE Charlottesville, VA 22901
1	US Army Armor and Engineer Bd ATTN: STEBB-AD-S Fort Knox, KY 40121	2	Commander US Army Training & Doctrine Cmd ATTN: ATCD ATCD-M Fort Monroe, VA 23651
1	Project Manager M-60 Tank Development ATTN: DRCPM-M60TD Warren, MI 48090	3	Director US Army TRADOC Systems Analysis Activity ATTN: ATAA-SL ATAA-TFB ATAA-TEM White Sands Missile Range NM 88002
2	Program Manager M1 ABRAMS Tank System ATTN: DRCPM-GCM-S Warren, MI 48090	1	Commander US Army Field Artillery School Ft Sill, OK 73503
1	Project Manager Fighting Vehicle Systems ATTN: DRCPM-FVS Warren, MI 48090	3	Commandant US Army Infantry School ATTN: Infantry Agency 'ATSH-CD-CSO-OR (2 cys) Fort Benning, GA 31905
1	Project Manager Tank Main Armament Systems ATTN: DRCPM-TMA-PA Dover, NJ 07801	3	Commander US Army Armor Center ATTN: ATZK-CG ATZK-CD ATZK-M1 Fort Knox, KY 40121
1	Commander Combined Arms Center ATTN: ATZL-CG Fort Leavenworth, KS 66027	3	Commander Naval Weapons Center ATTN: Mr. Mel Keith - 31804 Mr. Rex Randolph Mr. Jack Bates China Lake, CA 93555
1	Commander US Army Combined Arms Combat Developments Activity ATTN: ATCA-SA Fort Leavenworth, KS 66027		
1	Commander Concepts Analysis Agency 8120 Woodmont Avenue Bethesda, MD 20014		

DISTRIBUTION LIST

<u>No. of Copies</u>	<u>Organization</u>	<u>No. of Copies</u>	<u>Organization</u>
1	Commandant US Marine Corps ATTN: APW, LTC Egan Washington, DC 20380		
2	Commander Marine Corps Development and Education Command ATTN: Plans and Studies Div Firepower Div Quantico, VA 22134		
1	AFELM, The Rand Corporation ATTN: Library-D 1700 Main Street Santa Monica, CA 90406		

ABERDEEN PROVING GROUND

Dir, USAMSAA  
ATTN: DRXSY-D  
DRXSY-MP (H. Cohen)

Cdr, USATECOM  
ATTN: DRSTE-TO-F

Dir, USACSL, Bldg E3516, EA  
ATTN: DRDAR-CLB-PA  
DRDAR-CLN  
DRDAR-CLJ-L

USER EVALUATION OF REPORT

Please take a few minutes to answer the questions below; tear out this sheet, fold as indicated, staple or tape closed, and place in the mail. Your comments will provide us with information for improving future reports.

1. BRL Report Number \_\_\_\_\_

2. Does this report satisfy a need? (Comment on purpose, related project, or other area of interest for which report will be used.)

\_\_\_\_\_

\_\_\_\_\_

3. How, specifically, is the report being used? (Information source, design data or procedure, management procedure, source of ideas, etc.) \_\_\_\_\_

\_\_\_\_\_

4. Has the information in this report led to any quantitative savings as far as man-hours/contract dollars saved, operating costs avoided, efficiencies achieved, etc.? If so, please elaborate.

\_\_\_\_\_

5. General Comments (Indicate what you think should be changed to make this report and future reports of this type more responsive to your needs, more usable, improve readability, etc.) \_\_\_\_\_

\_\_\_\_\_

6. If you would like to be contacted by the personnel who prepared this report to raise specific questions or discuss the topic, please fill in the following information.

Name: \_\_\_\_\_

Telephone Number: \_\_\_\_\_

Organization Address: \_\_\_\_\_

\_\_\_\_\_

\_\_\_\_\_