

MICROCOPY RESOLUTION TEST CHART
NATIONAL BUREAU OF STANDARDS-1963-A

(2)



FRANK J. SEILER RESEARCH LABORATORY
FJSRL-TR-83-0011 OCTOBER 1983

SCALE MODEL TESTING FOR CONTROL SYSTEM
PARAMETERS OF LARGE STRUCTURES

FINAL REPORT

DTIC
SELECTED
DEC 13 1983
A

LT COLONEL RICHARD T. EVANS
MR. BILL J. SIMMONS
LIEUTENANT STEVEN M. BROWN
LIEUTENANT DAVID A. ERCHINGER
LIEUTENANT MARK E. MATHEWS

USAF A ENGR 430/ASTRO 499 APPROVED FOR PUBLIC RELEASE;
DISTRIBUTION UNLIMITED.

AIR FORCE SYSTEMS COMMAND

UNITED STATES AIR FORCE

83 12 12 013

FINAL REPORT

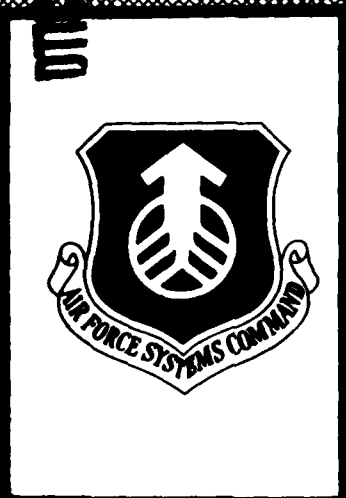

This document was prepared by the Aerospace-Mechanics Directorate, Frank J. Seiler Research Laboratory (FJSRL), United States Air Force Academy, CO. The research was conducted as a joint effort by FJSRL and the Astronautics Department of the United States Air Force Academy faculty and students.

When U.S. Government drawings, specifications or other data are used for any purpose other than a definitely related government procurement operation, the government thereby incurs no responsibility nor any obligation whatsoever, and the fact that the government may have formulated, furnished or in any way supplied the said drawings, specifications or other data is not to be regarded by implication or otherwise, as in any manner licensing the holder or any other person or corporation or conveying any rights or permission to manufacture, use or sell any patented invention that may in any way be related thereto.

Inquiries concerning the technical content of this document should be addressed to the Frank J. Seiler Research Laboratory (AFSC), FJSRL/NHG, USAF Academy, Colorado Springs, CO 80840. Phone AC 303 472-3502.

This report has been reviewed by the Commander and is releasable to the National Technical Information Service (NTIS). At NTIS it will be available to the general public, including foreign nations.

This technical report has been reviewed and is approved for publication.



BILL J. SIMMONS
Project Scientist



ALBERT J. ALEXANDER, Major, USAF
Director, Aero-Space Mechanics



THEODORE T. SAITO, Lt Col, USAF
Commander

Copies of this report should not be returned unless return is required by security considerations, contractual obligations, or notice on a specific document.

Printed in the United States of America. Qualified requestors may obtain additional copies from the Defense Technical Information Center. All others should apply to: National Technical Information Service
6285 Port Royal Road
Springfield, Virginia 22161

UNCLASSIFIED

SECURITY CLASSIFICATION OF THIS PAGE

REPORT DOCUMENTATION PAGE

1a. REPORT SECURITY CLASSIFICATION UNCLASSIFIED			1b. RESTRICTIVE MARKINGS		
2a. SECURITY CLASSIFICATION AUTHORITY			3. DISTRIBUTION/AVAILABILITY OF REPORT Approved for public release; Distribution Unlimited		
2b. DECLASSIFICATION/DOWNGRADING SCHEDULE			4. PERFORMING ORGANIZATION REPORT NUMBER(S) FJSRL-TR-83-0011		
6a. NAME OF PERFORMING ORGANIZATION Frank J. Seiler Research Lab			5b. OFFICE SYMBOL (If applicable) FJSRL/NHG	5. MONITORING ORGANIZATION REPORT NUMBER(S)	
6c. ADDRESS (City, State and ZIP Code) USAF Academy Colorado Springs, CO 80840			7a. NAME OF MONITORING ORGANIZATION		
8a. NAME OF FUNDING/SPONSORING ORGANIZATION		8b. OFFICE SYMBOL (If applicable)	9. PROCUREMENT INSTRUMENT IDENTIFICATION NUMBER		
8c. ADDRESS (City, State and ZIP Code)			10. SOURCE OF FUNDING NOS.		
			PROGRAM ELEMENT NO.	PROJECT NO.	TASK NO.
			612308		2308
11. TITLE (Include Security Classification) Scale Model Testing for Control System Parameters of Large Structures (U)			WORK UNIT NO.		
12. PERSONAL AUTHOR(S) Evans, Richard T.; Simmons, Bill J.; Brown, Steven M.; Erchinger, David A. Mathews, Mark E.					
13a. TYPE OF REPORT Final		13b. TIME COVERED FROM Aug 82 to Aug 83	14. DATE OF REPORT (Yr., Mo., Day) October 1983		15. PAGE COUNT 36
16. SUPPLEMENTARY NOTATION					
17. COSATI CODES			18. SUBJECT TERMS (Continue on reverse if necessary and identify by block number)		
FIELD	GROUP	SUB. GR.	Large Space Structures, Structural Dynamics, Modal Analysis, Control Parameters, Scale Model Tests, Structural Resonances		
	2202	-2309			
	1313				
19. ABSTRACT (Continue on reverse if necessary and identify by block number)					
<p>The premise is made that as an alternate to or enhancement to finite element analysis of a large complex structure, scale model tests can provide useful parameters for control system design. The objective is to minimize risks associated with expensive construction of large complex space structures by better predictions of the associated structural dynamics. This report covers construction of scale models of an existing, well-modeled, complex structure, the experimental modal analysis of the scale models, and comparison of scale model parameters to the full-size structure. A comparison of the results obtained for three scale models yields general relationships that can be applied to future large complex structure development and to a conclusion that structural characteristics pertaining to control system parameters can be determined from scale model tests.</p>					
20. DISTRIBUTION/AVAILABILITY OF ABSTRACT UNCLASSIFIED/UNLIMITED <input checked="" type="checkbox"/> SAME AS RPT. <input checked="" type="checkbox"/> DTIC USERS <input type="checkbox"/>			21. ABSTRACT SECURITY CLASSIFICATION UNCLASSIFIED		
22a. NAME OF RESPONSIBLE INDIVIDUAL Bill J. Simmons			22b. TELEPHONE NUMBER (Include Area Code) (303) 472-3502		22c. OFFICE SYMBOL FJSRL/NHG

DD FORM 1473, 83 APR

EDITION OF 1 JAN 73 IS OBSOLETE.

UNCLASSIFIED
SECURITY CLASSIFICATION OF THIS PAGE

TABLE OF CONTENTS

	Page No.
List of Figures	11
Summary	111
Preface	1
Introduction	3
Approach	4
General	4
Large Complex Structure Analysis	4
Small Scale Structure Design	5
Small Scale Structure Construction	8
Experimental Modal Analysis	9
Test Result Comparison	11
Results	12
General	12
Modal Frequencies	12
Damping Coefficients	12
Mode Shapes	13
Additional Tests	18
General	18
High Modal Density Test	18
Half-Power Point Damping Determination	19
Discussion	23
General	23
Modal Frequencies	23
Damping	25
Modal Shapes	26
Conclusions	27
Acknowledgements	27
References	29



SEARCHED
 INDEXED
 SERIALIZED
 FILED
 APR 1965
 FBI - MEMPHIS
 AL

LIST OF FIGURES

	Page No.
1. Iso-Pad Pictorial	6
2. Scale Model Cross Section	7
3. Geometry/Test Hardware	10
4. Iso-Pad Bode Plot	11
5. Iso-Pad $F_1=46.4$ Hz	14
6. Iso-Pad $F_2=57.4$ Hz	14
7. Iso-Pad $F_3=64.8$ Hz	14
8. Iso-Pad $F_4=66.9$ Hz	14
9. Iso-Pad $F_5=120.9$ Hz	15
10. 1:16.25 Model $F_1=712.8$ Hz	16
11. 1:16.25 Model $F_2=878.8$ Hz	17
12. 1:16.25 Model $F_3=985.8$ Hz	17
13. 1:16.25 Model $F_4=1102.1$ Hz	17
14. 1:16.25 Model $F_5=2004.8$ Hz	17
15. 1:16.25 Model $F_3=1011.3$ Hz by MODAL PLUS With 'Dwell' Excitation	20
16. 1:16.25 Model $F_4=1047.2$ Hz by MODAL PLUS With 'Dwell' Excitation	20
17. Damping Coefficient by Log-Decrement	22
18. Damping Coefficient by Half-Power Point	22

SUMMARY

Prior to construction and deployment of large flexible space systems with complex modal characteristics, it is critical to predict how the structure will be controlled. Analytical models from finite element analysis can only provide a limited degree of confidence prior to full scale construction. Ground testing of small scale models offers a feasible alternative that is cost effective if reliable. Fabrication and tests of small scale models of a large complex structure is evaluated in this paper. The structural and modal characteristics of the Frank J. Seiler Research Laboratory's pneumatic isolated inertial instrument test platform (Iso-Pad) and three representative scale models are described. The experimentally determined parameters of interest, including the mode shapes, the modal frequencies, and the associated damping coefficients at the first five resonant frequencies, are presented. A comparison of the results obtained for the three models yields general relationships that can be applied to future large complex structure modeling.

PREFACE

During meetings between FJSRL and USAF Academy faculty in 1981-82 on potential problem areas for joint research on space structural dynamics, the suggestion by Mr. Simmons for scale model testing of modal parameters was discussed. In planning the 1982 fall semester, the scale model testing concept was proposed by Lt Col R.T. Evans (FJSRL) as an Engineering 430 class research problem. Lt Col Evans was assigned instructor, Major T.G. Minnich, Department of Astronautics (DFAS), was course director, and Mr. B.J. Simmons (FJSRL) was advisor for the approved Eng 430 class which was to consist of 17 first-class (senior) cadets. The Eng 430 class fabricated and tested two scale models of the Iso-Pad and the results are reported in an FJSRL Technical Memorandum. The shortcomings in the scale model designs were recognized, and in January 1983, Captain George C. Nield, Department of Astronautics (DFAS), obtained approval for an ASTRO 499 (Department of Astronautics) class with objectives of analysis and construction of an accurate scale model, and modal analysis test to determine realistic accuracies in modal parameters. The class, consisting of Cadet First Class S.M. Brown and Cadet First Class D.A. Erchinger, with Evans and Simmons as advisors, also had as an objective the presentation of a paper. Their results were summarized in AIAA Paper No. 83-2225 to the Guidance and Control Conference in Gatlinburg, TN, in August 1983. The results on modal testing of a 1/16.25 scale model showed very accurate determination of full-size structural mode shapes and frequencies. Damping coefficients of

the scale model obtained by MODAL-PLUS were not representative of those of the full-size structure. As stated by Capt. Nield and others, the determination of modal damping coefficients was of such importance that even an order of magnitude determination would be of significant value to the controls system design. In July 1983, Lt Mark E. Mathews was assigned to FJSRL and continued the scale model testing task with the objective of a determination of modal damping comparison using other analysis techniques. This work was successful but was not completed in time to be included in the AIAA paper.

This report includes the basic results generated by the three phases of this research task, namely, the Eng 430 class, the ASTRO 499 class, and the research work by Lt Mathews during the summer of 1983.

INTRODUCTION

Understanding how a large complex structure will perform in space is a prerequisite to successfully constructing and deploying such systems. Since testing full scale structures in space could prove costly and dangerous, an alternative method to predict the performance of large complex structures must be sought. Theoretical analysis, utilizing finite element models, has been relied upon in the past to provide the modal characteristics of structures. Fabrication and ground testing of small scale models offers a feasible alternative for acquiring the vital modal parameters. Verifying the functional relationship between the modal characteristics of small scale models and the large complex structures they represent would encourage the use of ground testing of scale models for future large complex space structure analysis.

Fabrication and tests of small scale models of an existing large complex structure is evaluated in this paper. The complex structure selected for comparison tests was the EJSRL/USAF Academy's large pneumatically isolated inertial instrument test platform (Iso-Pad). While far from being a 'space' structure, it is a very well modelled structure with both finite element analysis by NASTRAN and experimental analysis by MODAL-PLUS* models. Three scale models of the Iso-Pad were constructed and modelled by MODAL-PLUS. The experimentally determined parameters of

*MODAL-PLUS is a Copyright Program by the Structural Dynamics Research Corporation.

Interest including the modes shapes, the modal frequencies, and the associated damping coefficients at the first five resonant frequencies are presented. A comparison of the results obtained for the three models were made to determine what, if any, general relationships could be applied to future large complex structure modeling.

APPROACH

General

Deriving a mathematical relationship for the modal parameters of interest, using the scale modeling process, involves five steps: 1) Full scale structure analysis, 2) Design of the small scale model, 3) Scale structure construction, 4) Experimental modal analysis of the scale model, and finally, 5) Comparison of scale model test results with data from the full size structure. Following the completion of the initial phase of the scale modeling process, the above procedure was repeated for each of three small models scaled to 1:12, 1:14, and 1:16.25.

Large Complex Structure Analysis

The Isolation pad (Iso-Pad) located at the United States Air Force Academy is an existing complex structure that has been theoretically and experimentally modeled. It is a principle feature of the Frank J. Seiler Research Laboratory's guidance and control facilities and was constructed as a test platform for inertial navigation system components supplied to the Air Force. The pneumatically support structure is 25 x 25 x 9 feet and weighs 450,000 lbs. The physical configuration of the Iso-Pad has been described in detail by Col J.P. Wittry¹. The soft spring/mass

system support effected by the pneumatic support makes the Iso-Pad an ideal specimen for 'free body' experimental analysis. The requirement for tests of more precise inertial grade gyroscopes and accelerometers led to increased demands on the stability of the test platform. The dependence of the Iso-Pad rigorous control dynamics on the structural dynamics led to improved modeling of the structure². Thus, both theoretical, finite element analysis by NASTRAN, and experimental modal analysis by MODAL-PLUS are available on this complex structure³. Figure 1 illustrates the Iso-Pad's basic configuration.

Small Scale Structure Design

Dimensional characteristics, materials and reinforcement were considerations included in the design of the three scale model of the Iso-Pad. Reducing the dimensional scale of a structure imposes additional design constraints that impact the design. To accurately maintain a 1:16.25 scaling ratio in the smallest of the three models a dimensional tolerance of 1/32" was specified for the wood form. The density of the reinforced concrete employed for the models must correspond to that used in the full scale structure since the expected resonant frequency is a function of the structure's mass, according to the following equation:

$$\omega = \sqrt{k/m} \text{ where } k = EI/L^3 \text{ and } m = \rho L^3$$

and K = stiffness
 ω = resonant frequency
M = structural mass
I = moment of inertia
E = Young's modulus
 ρ = density

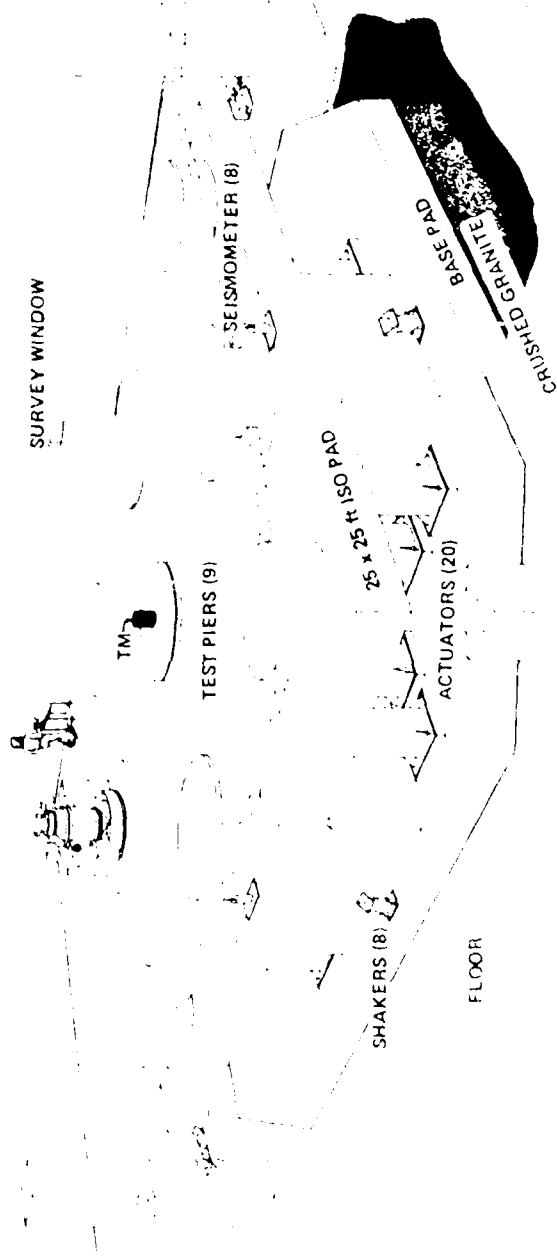

Figure 1. Iso-Pad Pictorial

Likewise the stiffness of the scale model, which is dependent upon the ratio of steel reinforcement in the structure to the amount of concrete mixture, must be maintained in the design to obtain an accurately representative model. The reduction in scale of the ten sonotubes included in the original large complex structure presented a problem that commonly occurs when reducing the dimensional scale of a concrete structure. An inch minimum cover of concrete mixture must be maintained around the sonotubes as well as the reinforcing bar. This design criteria conflicts with the specification that would call for a hollow tube of greater diameter than modeling to 1:16.25 scale would allow. Figure 2 illustrates a cross section of the structure and the competing design criteria with the sonotubes.

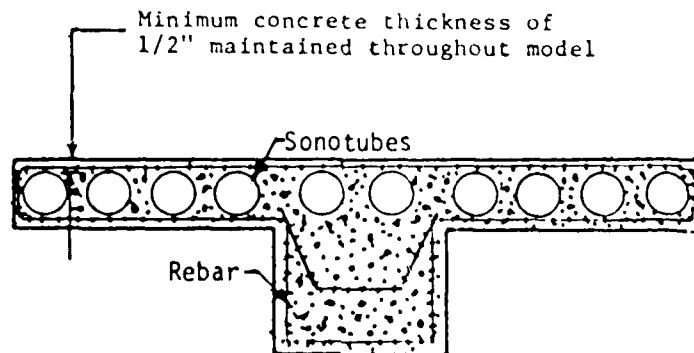

Figure 2. Scale Model Cross Section

Small Scale Structure Construction

Since all dimensional irregularities are magnified by as much as 16.25 (in the case of the smallest model) when compared to the original Iso-Pad, great care must be employed throughout the fabrication phase to insure the small scale structures are accurate representations of the large complex structure. However, micro effects, e.g., molecular bond forces, may make a 'true' scale model impossible to achieve. For example, the stiffness requirement for the concrete determines the water to cement ratio and the weights of large and small aggregate to be included in the concrete mixture composition; however, scaling theory would appear to require that each component, water, cement and aggregate, be reduced in size by the appropriate scaling factor for each of the three models. The earlier 1:12 and 1:14 scale models contain increased quantities of water and cement, as no "large" aggregate was included in these mixtures. A maximum size of 1/8" gravel was used for the 1:16.25 model (scaled from 2" in the Iso-Pad) in addition to the fine sand utilized in all three models⁴.

The nine test piers were modeled with lead disks on the three small scale structures for simplicity in fabrication and so that the actual loading conditions encountered during Iso-Pad testing could be duplicated. Melted lead was poured into metal molds of two sizes for each model to simulate different test pier sizes as shown in Figure 1. The test equipment pictured on the northern center test pier and a 1500 lb granite block attached to the center pier could be accurately modeled with the use of the more workable material.

The Fall 82 Eng 430 class of 17 cadets designed and constructed the 1:12 and 1:14 scale models. This class effort included the full set of tasks from proposal through design reviews, schedule, cost and management control, to acceptance demonstration as would be performed by a company performing on a government contract. As a consequence, time was of the essence and design and fabrication of the two models was less thorough than otherwise desired; and the two models had fabrication technique and dimensional errors. The test results were good, but cannot be considered as accurate as the 1:16.25 model developed by the ASTRO 499 class in the Spring 83 semester.

Experimental Modal Analysis

The equipment and technique employed for small scale structure data acquisition was substantially a duplication of that utilized for the initial testing of the Iso-Pad². The modal characteristics analysis was performed on a minicomputer using the MODAL-PLUS software package developed by the Structural Dynamics Research Corporation (SDRC). The program was operated on a PDP 11/05 computer, with 32K memory. In MODAL-PLUS several display modes are available to the user in addition to data collection and analysis routines. The specific functions used in structure testing include:

- 1) Definition of structure geometry
- 2) Calibration for multi-channel acceleration measurements
- 3) Calculation of natural frequency, associated damping coefficient, modal amplitudes, and phase relationships
- 4) Animation of structural vibration

Peripheral equipment used to support the operation of the MODAL-PLUS

program include one each RK05 auxiliary disk memory, Tektronix 4012 terminal, ACEMUX analog-to-digital signal conditioning equipment by Gen Rad, Inc., and Tektronix 4631 hard copy unit.

The program requires input signals to calculate the modal parameters of a structure. A PCB K291A impulse hammer kit provided the motion excitation of the structure and the impulse reference signal for the computer. Response point acceleration is typically one input for a single degree of freedom, or three inputs for three degrees of freedom, and the impulse hammer reference signal. The scale model responses were obtained with a BBN 505 triaxial accelerometer.

Figure 3 depicts the location of the reference impact point, the impulse hammer and the sensor attached by magnet to a metal washer on one of the 32 designated response points of the structure geometry. Ten samples were taken at each point and averaged by the computer to obtain a Bode graph at each of the designated locations.

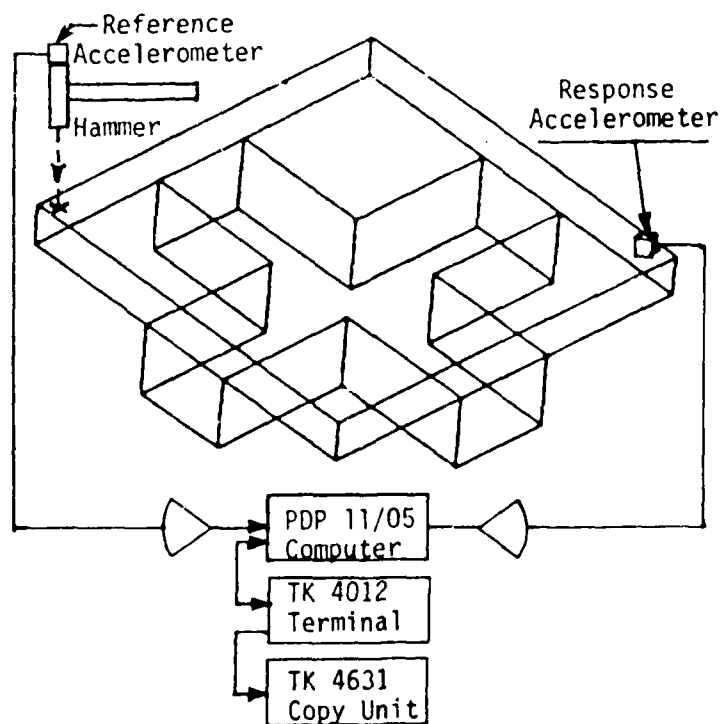

Figure 3. Geometry/Test Hardware

Test Result Comparison

While the MODAL-PLUS program is capable of computing the real and imaginary modal amplitudes, natural frequencies, viscous damping, and mode shapes, the latter three parameters are of primary interest for large complex structures control system development. The first five resonant frequency peaks were identified on the Bode graphs for each response point. A typical Bode plot of a response is shown in Figure 4. The MODAL-PLUS routine was used to calculate the frequencies and the associated damping coefficient at each of the identified peaks. The mode shapes are deformation patterns of the structure at a specific frequency. The MODAL-PLUS program was used to calculate and animate these mode shapes. The direction of movement of specific points on the small scale model was compared with similar plots for the Iso-Pad. The vibration of the four top corners are of critical concern for each mode shape and were the comparison criteria to verify particular data sets. The resulting mode shapes, frequencies, and damping coefficients from scale model tests, were compared to previously recorded results from the Iso-Pad. The relationship between the structural characteristics of the large complex structure and the scale models was investigated.

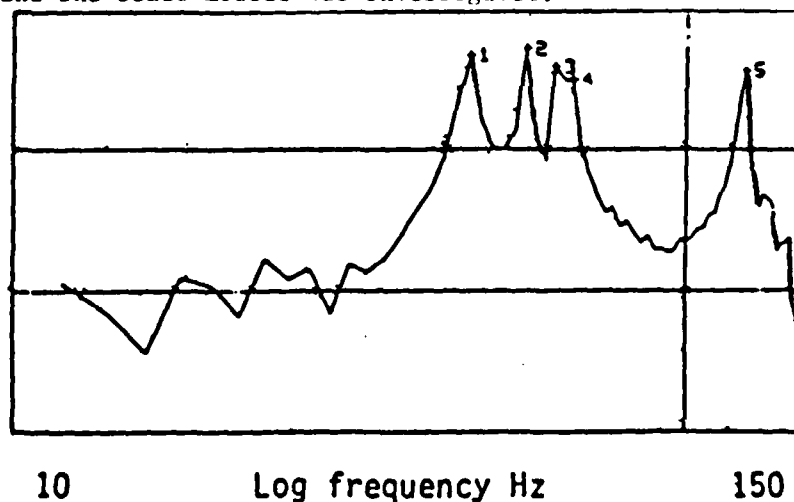

Figure 4. Iso-Pad Bode Plot

RESULTS

General

The modal parameters for each of the three small scale models were obtained from the MODAL-PLUS program as described in the experimental modal analysis procedure. Modal frequencies, their associated damping coefficients, and mode shapes for each of the first five resonant peaks on the bode plots are presented.

Modal Frequencies

The modal frequencies are determined by a MODAL-PLUS routine which computes a best fit response over a frequency range which includes several resonances. The result may actually differ slightly from a precise Fourier analysis. This would account for the differences in the 1974 observed frequencies⁵ from the MODAL-PLUS parameter calculations. Table 1 contains early 1974 frequency analysis of the Iso-Pad, and the MODAL-PLUS calculated frequencies for the large complex structure. The last three columns tabulate the experimentally determined frequencies for the accurate 1:16.25 model and the two inferior small scale models.

Table 1. Modal Frequency Results (Hz)

Mode Label	Observed 1974	Experimentally determined with MODAL-PLUS			
		Iso-Pad	1:12 Model	1:14 Model	1:16.25 Model
F ₁	48	46.4	591.7	729.6	712.8
F ₂	59	57.4	806.2	959.6	878.8
F ₃	65	-	-	-	985.8
F ₄	67	66.9	882.0	1107.7	1102.1
F ₅	121	120.9	1727.2	1993.4	2004.8

Damping Coefficients

The damping coefficient is one of the more important modal parameters that can be calculated with the MODAL-PLUS program. The results from the Iso-Pad and three scale models is contained in Table 2. Aside from

consideration of how these figures compare, the damping coefficient is important to determination that a 'real' mode has been identified. Low damping coefficients, $\gamma < 0.1$, are usually associated with natural resonant vibrations, while a high value of the damping coefficient indicates that other factors such as the 180° phase change at a resonance should be used to verify a resonance.

Table 2. Damping Coefficient Results

<u>Mode Label</u>	<u>Iso-Pad</u>	<u>1:12 Model</u>	<u>1:14 Model</u>	<u>1:16.25 Model</u>
F ₁	.0001	.0060	.0071	.0180
F ₂	.0169	.0256	.0032	.0316
F ₃	-	-	-	.0065
F ₄	.0188	.0791	.0078	.0173
F ₅	.0049	.0166	.0181	.0163

As is noted later, under 'Discussion', there is no linear correlation in MODAL-PLUS results on damping coefficients between the Iso-Pad and the scale models. Additional tests to determine these parameters more accurately than possible with MODAL-PLUS were conducted (see 'Additional Tests' below).

Mode Shapes

The structural deformation patterns of the Iso-Pad at each of the first five resonant frequencies are depicted in Figures 5-9. Arrows have been added to the computer generated diagrams to indicate relative direction of movement for a few points on the structure. The first mode, 46.4 Hz shows a bending shape where opposite corners of the structure are in phase (See Figure 5). The second mode 57.4 Hz could be characterized as the vertical mode as all four corners move vertically in phase (See Figure 6).

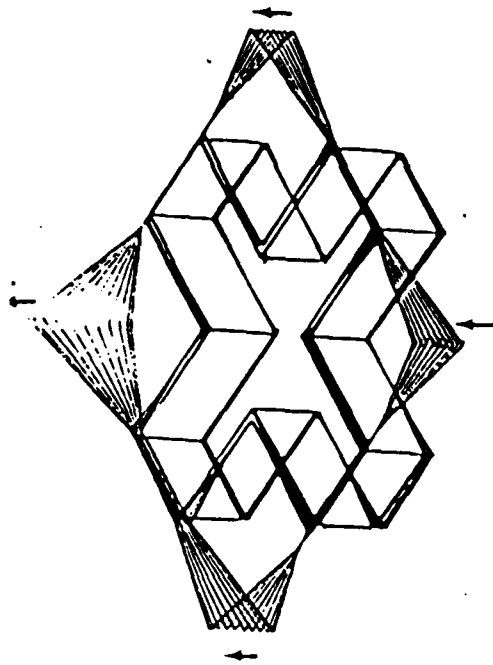

Fig. 5 Iso-Pad $F_1=46.4$ Hz

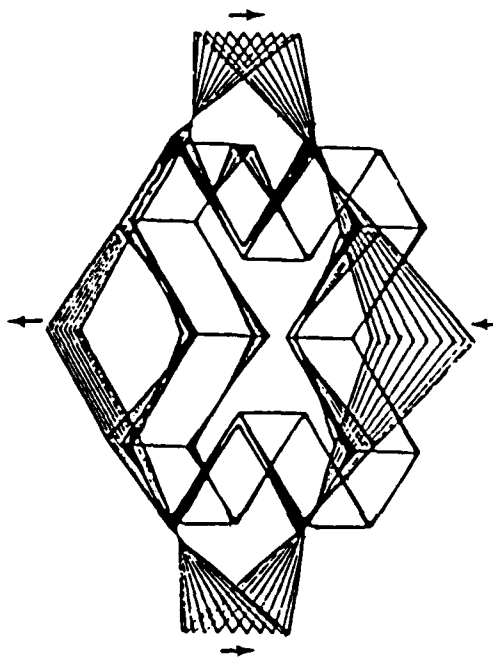

Fig. 6 Iso-Pad $F_2=57.4$ Hz

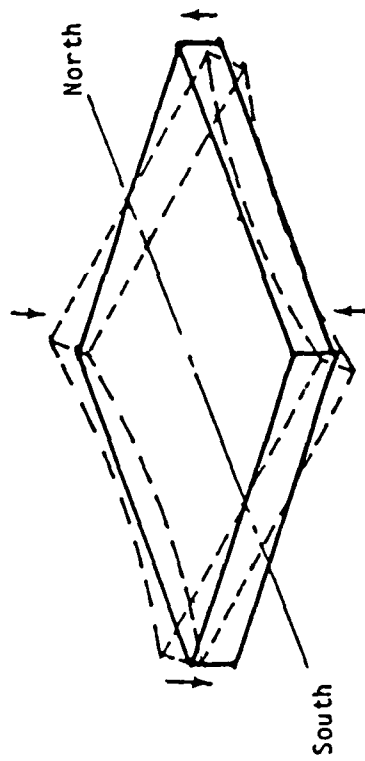

Fig. 7 Iso-Pad $F_3=64.8$ Hz

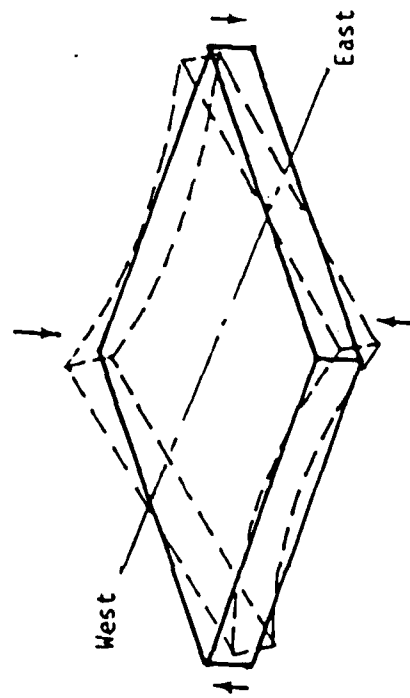

Fig. 8 Iso-Pad $F_4=66.9$ Hz

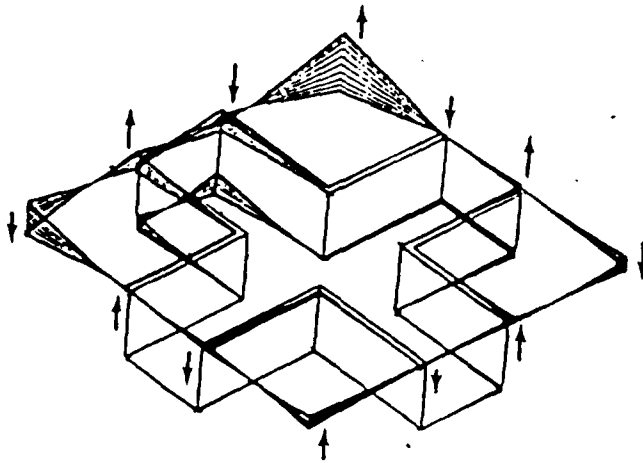

Fig. 9 Iso-Pad $F_5=120.9$ Hz

The third and fourth modes depict torsion about the center axis. Two similar frequencies were determined to exist during testing of the Iso-Pad in 1975. Oscilloscope comparison and Fourier analysis power spectrum were used to obtain accurate resonant frequencies and approximate mode shapes. The illustrations of Figures 7 and 8 are sketches of the Iso-Pad's top plane to clarify the differences between these two modes. Figure 7 shows the 65 Hz mode in torsion about the EW axis. The slightly higher 67 Hz mode differs due to the non symmetrical loading and single direction of the ten sonotubes. Figure 8 demonstrates the torsion mode about the NS axis. A shape calculation could not be generated by the MODAL-PLUS program for the 65 Hz mode since it was less excited by the impact at the SE corner; however, the broadening effect of the two modes can be observed on the Bode plot (See Figure 4). Tests to better define the frequency

band of two closely spaced modes were conducted later (See 'Additional Tests') with good results and the technique is potentially applicable to any high modal density frequency band.

A structural resonance at a frequency of 120.9 Hz yields a more complex mode shape than the previous four modes. In Figure 9 the top four corners of the plane would appear to indicate that the mode is a higher order function of the first mode. The thick cruciform and nonlinear loading condition prevent the deformation pattern from a harmonic of the first mode. Higher resonant frequencies up to 5 KHz were observed in the 1974 testing; however, only the lower frequency modes were of interest to the research at the time.

Figures 10-14 depict the structural deformation patterns which were experimentally determined from the MODAL-PLUS program for the 1:16.25 scale model. Again, arrows have been drawn to indicate the relative motion of significant points on the structure, and to aid in comparison to the mode shape plots for the full size Iso-Pad. It will be noted that mode shapes F_3 and F_4 have poor definition of corner movement, and that some 'interior' points of the structure indicate unrealistically large deflections.

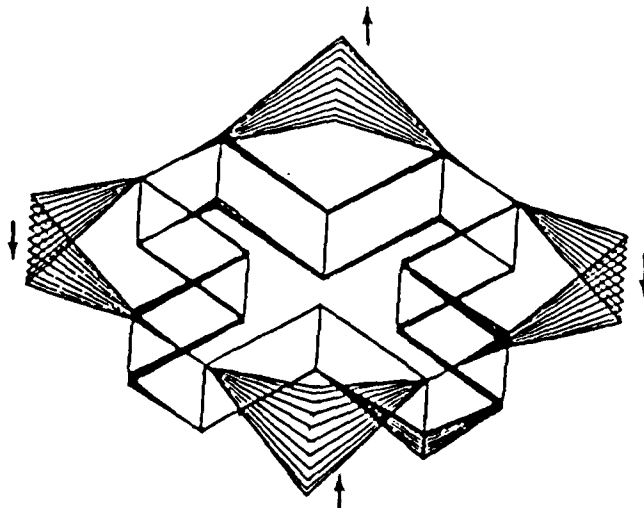

Fig. 10 1:16.25 model $F_1=712.8$ Hz

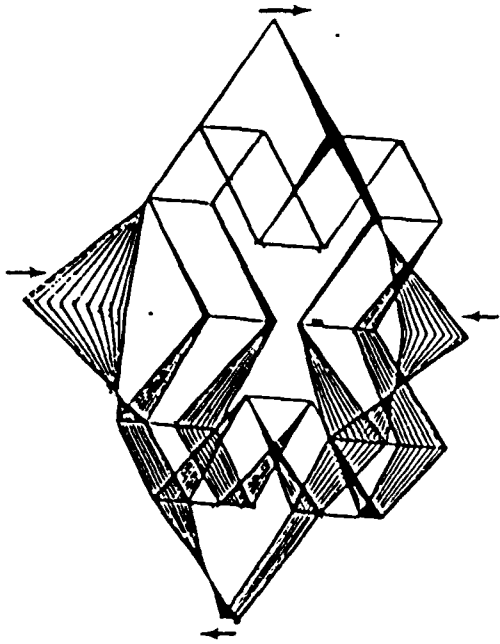

Fig. 12 1:16.25 model $F_3=985.8$ Hz

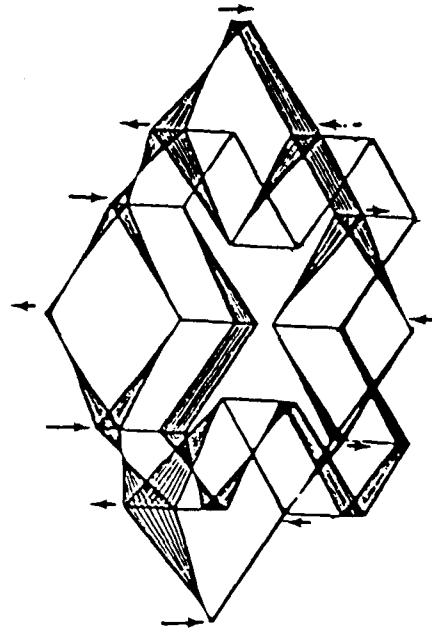

Fig. 14 1:16.25 model $F_5=2004.8$ Hz

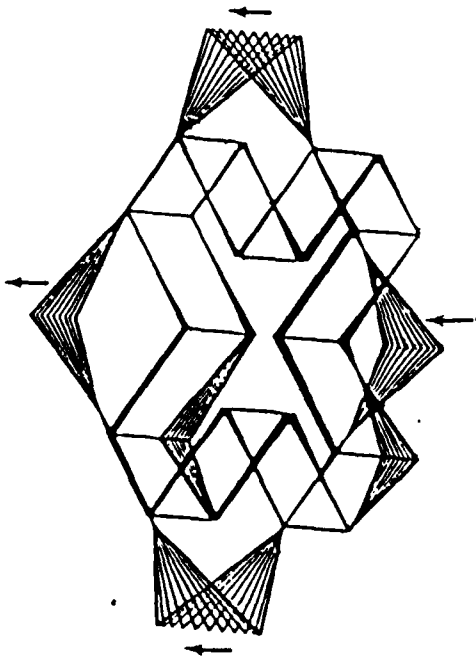

Fig. 11 1:16.25 model $F_2=878.8$ Hz

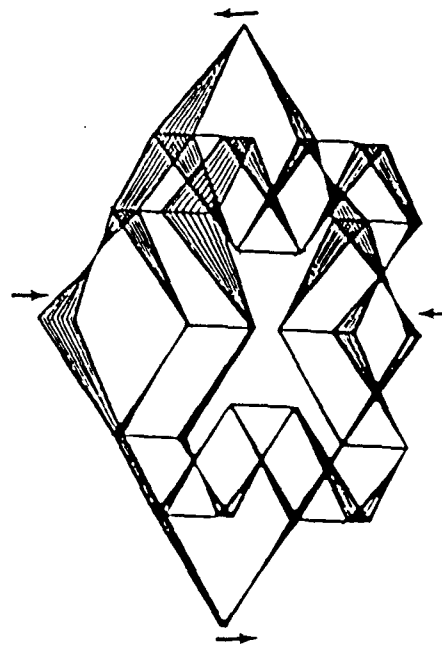

Fig. 13 1:16.25 model $F_4=1102.1$ Hz

ADDITIONAL TESTS

General

Two areas have been noted under 'Results' in which the normal MODAL-PLUS analysis did not provide adequate information. These were the distinctive identification of the two closely spaced mode shapes F_3 and F_4 and lack of useful comparisons of damping coefficients. The following test techniques were applied in the work of Lt Matthews.

High Modal Density Test

The purpose of this experiment was to use a small scale model to study two closely coupled modes of vibrations. The structure to be modeled is the Iso-Pad which was observed in 1974 to have two torsion modes at frequencies of 65 Hz and 67 Hz, which corresponds to the 1:16.25 scale model frequencies of 985.8 and 1102.1. MODAL-PLUS analysis, using impact excitation, revealed F_3 and F_4 rather poorly. These two modes were further investigated by the techniques described in the following.

Previous MODAL-PLUS tests had used impact excitation at the SE corner of the scale model, as was performed previously on the Iso-Pad. The MODAL-PLUS results did not clearly show a separation of two torsion modes. Better definition was attempted using random excitation of the scale models with a shaker first at other corners and then along the sides of the structure. A fair separation of the two peaks were obtained on a Bode plot; but this still did not provide a good MODAL-PLUS calculation of mode shapes. Note in Figures 12 and 13 the gross distortions of shapes, large motion of interior points, and very small motion of some corners.

As a further test, the 16.25:1 model was set up with a shaker at the NE corner with a sine wave generator input to the shaker. Located at a corner, the shaker would be exciting a point of maximum displacement. An accelerometer was placed on the corner, and then a sine sweep excitation was used to find the natural frequencies. Two natural frequencies were found at 1010 and 1050 Hz with the models literally "humming" at these two frequencies. The accelerometer was moved to each corner and the output compared to the shaker reference. Using this oscilloscope comparison, the lower frequency, 1010 Hz, showed the NE and NW corners vibrating in phase while the SE and SW corners vibrated 180° out of phase. At the higher frequency, the NW and SW corners vibrated 180° out of phase. Thus, one sees the scale model creating the same shift from E-W to N-S as expected.

Knowing the two modes exist, MODAL-PLUS was used in the modal investigation to further define these two modes. Because MODAL-PLUS does not provide meaningful results with a single frequency input, a sine wave of 1050 Hz and a random noise signal were added. This 'dwell' technique provided a concentrated input, and yet, a broad signal for use by the computer software. The response accelerometer output was recorded at the four corners and at the midsides for data reduction. The mode shapes from MODAL-PLUS of the 16.25 scale model closely resembled the modes expected (see Figures 15 and 16).

Half-Power Point Damping Determination

The other area of special testing, where the improved or confirmed data from MODAL-PLUS was desired, was on determination of modal damping. A correlation between the model and the structure damping would provide

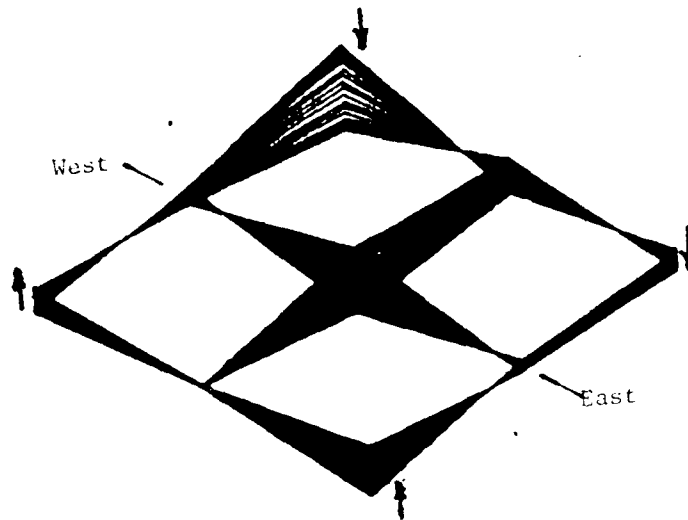

Figure 15. 1:16.25 Model F3=1011.3 Hz by MODAL PLUS
With 'Dwell' Excitation

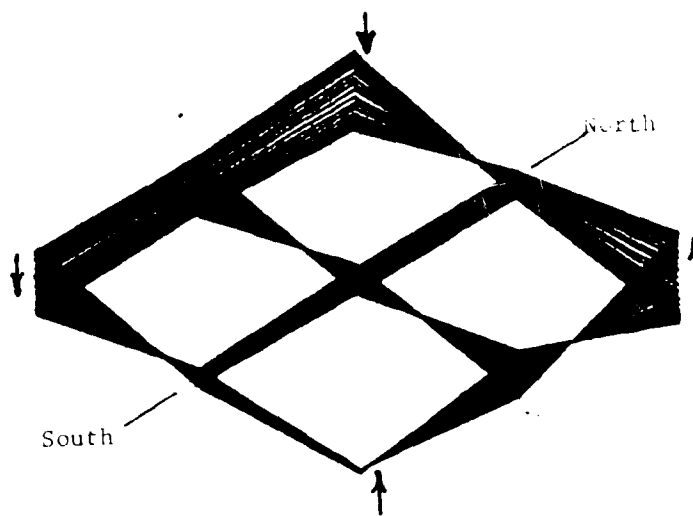

Figure 16. 1:16.25 Model F4=1047.2 Hz by MODAL PLUS
With 'Dwell' Excitation

valuable information for control engineers. An investigation into the modal dampening coefficients and relative amplitude between the actual Iso-Pad and the scale model was performed.

First, damping coefficients from MODAL-PLUS were compared. Next, two more direct experimental methods were investigated, log decrement and the half-power point method. The log decrement is the natural logarithm of the ratio of any two successive peaks, X_i , in the resonant frequency decay. The relationship of the damping coefficient, ξ , to the log decrement, Δ , (Figure 17) is given by the following⁶:

$$\Delta = \log \frac{x_m}{x_{m+1}}, \quad \xi \approx 1/2 \pi \Delta \quad \text{for } \xi \ll 1$$

In the log decrement an impact hammer provided the input while a band pass filter and an accelerometer showed the resonant decay for the mode of interest. In the half-power point method, a log plot of frequency versus power (power spectrum) from a random noise shaker input, provided the data base. The damping coefficient of the mode determines the Q or sharpness of the resonant peak. The ratio of the half-power point frequency difference, $\Delta\omega$, to the resonant frequency, ω_m , is a measure of the damping coefficient. The coefficient is calculated⁶ as follows (See Figure 18):

$$Q = \frac{\omega_m}{\Delta\omega}; \quad \xi = \frac{1}{2Q}$$

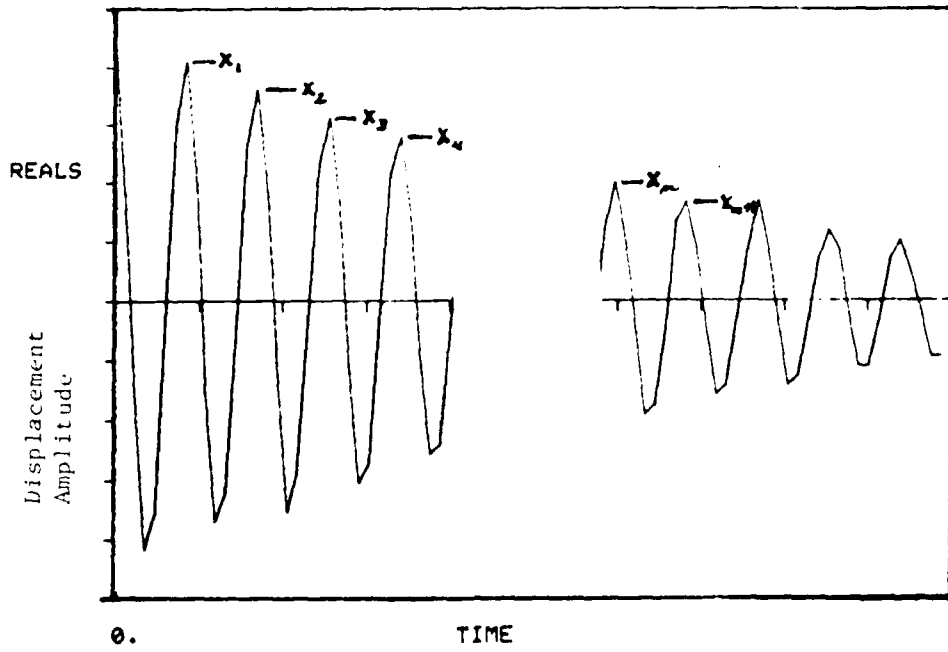

Figure 17. Damping Coefficient by Log-Decrement

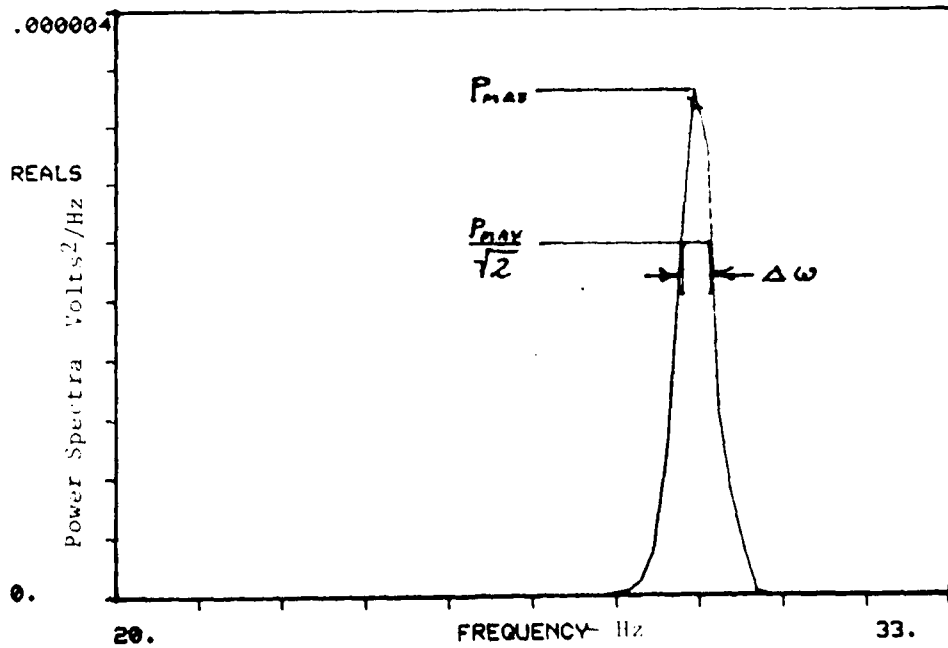

Figure 18. Damping Coefficient by Half-Power Point

A Fourier analyzer program can be used to increase the accuracy of the half-power point measurement by averaging many frames of data for the base power spectra. Likewise, the decrease in cycle amplitude for a log decrement calculation could be taken over several cycles of amplitude vs time data, and several frames averaged for greater accuracy. However, the available fast Fourier analyzer (FFA) made the frame averaging of power spectra easy to mechanize and is therefore considered more accurate.

DISCUSSION

General

The three modal characteristics; modal frequencies, associated damping coefficients, and mode shapes, were compared for each of the three models against the Iso-Pad. Scale factor was tested for each modal to determine whether a functional relationship existed, and to what degree of confidence, or accuracy, if such a conclusion was found. Only the parameters associated with the first five modes were examined.

In the comparison tables of modal frequencies below, only the comparison of the Iso-Pad and the 1:16.25 model is shown. The inferior models did not compare so well, with errors as large as 19%. This illustrates, at least, the importance of accuracy in application of the scale factor to all dimensions and, to the extent practical, other details of the construction, e.g., material, stiffness, and loading.

Modal Frequencies

The comparison of the modal frequencies and shapes of the Iso-Pad to the 1:16.25 accurate scale model was expected to have the most promise of

a generalized association. Table 3 shows the actual frequencies for the Iso-Pad and model. In the fourth column, the natural resonant frequency, f_N , projected for the Iso-Pad by dividing the experimental results of the model by the scale factor (SF), is tabulated as if a linear relationship existed. The close correlation between f_N/SF and the actual values obtained from the full scale complex structure may be seen. The error is a percent difference of f_N/SF from the Iso-Pad f_N 's. This error is at worst 6.6%. It should be noted that this significant error is in the F_3 mode, the high modal density band. The MODAL PLUS frequency results were shown in Table 1 for the 1:12 and 1:14 models.

The frequency tests in a band of high modal density by the sine sweep excitation technique results in lines 6 and 7 of Table 3. The percent error in frequency determination is not significantly improved over MODAL PLUS values; however, as seen below, the dwell excitation technique does improve shape determination.

Table 3. Frequency Comparison (Hz)

<u>Mode Label</u>	<u>Iso-Pad</u>	<u>1:16.25 Model</u>	<u>f_N/SF</u>	<u>% Error</u>
F ₁	46.4	712.8	43.9	-5.4
F ₂	57.4	878.8	54.1	-5.7
F ₃	(65)	985.8	60.7	-6.6
F ₄	(67)	1102.1	67.9	+1.5
F ₅	120.9	2004.8	123.4	+2.1
Sine Sweep (see Additional Tests)				
F ₃	(65)	1011	62.2	4.3
F ₄	(67)	1047	64.4	5.4

Damping

The damping coefficients, determined with MODAL PLUS, found for the individual modes in each of the three scale models failed to show any linear correlation with those recorded from the testing of the Iso-Pad (See Table 1). Likewise, no linear relationship between the damping coefficients and the five fundamental modes could be derived. While careful consideration was given to construction material and reinforcement of the third scale model in particular, no comparison of results indicated that a relationship between the damping coefficient for the first five modes existed.

The additional tests using the half-power point technique gave the damping coefficient results summarized in Table 4. Only two values were calculated using the less accurate log-decrement technique; the results differed from half-power point results by as much as x4. The MODAL PLUS values were noted as differing from the half-power point values by as much as two orders of magnitude. But, the comparison of values determined by the more accurate, half-power point technique, for the Iso-Pad vs the 1:16.25 scale model, show agreement on this limited sample basis, to no worse than a factor of two.

Table 4. Additional Damping Coefficient Results

<u>Mode Label</u>	<u>Iso-Pad</u>	<u>1:16.25 Model</u>
F ₁	.015	.030
F ₂	.020	.022
F ₃	-	-
F ₄	.018	.020
F ₅	.009	-

Modal Shapes

As a validation test for each set of test data taken, the direction and amplitude of the structural deformations in each mode shape were compared with those obtained previously for the Iso-Pad. Of particular concern was the direction each corner of the structure was vibrating in relation to the others. The most general criteria by which the data was tested was determining if the four corners were in phase with the full scale structure. The mode shape plots generated for the Iso-Pad appear in Figures 4 through 8, and the comparison plots for the 1:16.25 scale model are included as Figures 9 through 13. These shapes, Figures 4 through 13, were generated using MODAL PLUS and the standard impulse excitation technique. For each model, the final data set used did pass the validation test described above. While differences did exist in the relative amplitudes of some of the corners when compared to the Iso-Pad plots, the direction of the deformation matched for each model. It may be noted that the F_3 and F_4 modes, Figures 12 and 13, show almost no motion at the one or two of the key points, the corners. Only close inspection of the full size animation provided a clear phase relationship of these corners to the total shape. The dwell excitation technique provided the clarification of the F_3 and F_4 modes shown in Figures 15 and 16. There was no difficulty in determining the corner phase relationship from these modes using the dwell excitation and MODAL PLUS.

CONCLUSIONS

From the results of this effort, it is concluded that scale models do exhibit a linear relationship between size and modal frequencies to a high degree of confidence. The importance of designing the model as an accurate representation with precise linear scaling and attention to material properties was indicated. The scaling factor applied to the experimental scale model can be used to accurately predict the mode shapes and frequencies of a large structure. Also, scale models may yield approximate modal damping coefficients of sufficient accuracies to be useful to the control system development. The scale model data is at least a valuable enhancement to a theoretical analysis. And, the relatively small effort in careful design, fabrication, and test of scale models is rewarded with advance information at a fraction of the cost and schedule before risk of the investment of large structure development.

ACKNOWLEDGEMENTS

The authors would like to acknowledge and thank a number of people who contributed to the success of the program. These were professionals in the U.S. Air Force Academy's Departments of Astronautics (DFAS), Engineering Mechanics (DFEM), Civil Engineering (DFCE), faculty shop (DFSEA) and AFSC's Frank J. Seiler Research Laboratory (FJSRL). In particular, thanks to the following people: Lt Col T. Saito (FJSRL) and Lt Col T. Kullgren (DFEM) who supported a committee study of potential

joint FJSRL/USAF faculty research in the area of large space structures; Major W. Witt (DFAS), advisor on mechanical design and who suggested the Iso-Pad as the test structure; Captain G. Nield (DFAS), advisor on controls requirements; the Engineering 430 class director, Major T. Minnich; the cadets of the Engineering 430 class who made a success of their LOST (Large Object Scale Testing) project; Cadet First Class P. Amen, S. Brown, N. Burdick, D. Burns, C. Carnevale, E. Castor, T. Colburn, J. Dorsey, T. Duda, D. Erchinger, J. Jackson, F. McIlwain, S. Miller, T. Perry, C. Rosengrant, K. Shriner, and R. Smith; Captain L. Morey (DFCE), advisor on concrete properties; and Mr. J. Modrich (DFSEA) for precise fabrication of the 1:16.25 model form.

REFERENCES

1. Wittry, John P., "Description of an Inertial Test Facility Incorporating a Passively Isolated and Actively Stabilized Platform," AIAA Paper No. 69-863, August 1969.
2. Simmons, B.J., F.S. Heming, Jr., and F.E. Morgan, "An Investigation of the Dynamic Response of a Seismically Stable Platform," FJSRL-TR-82-0007, August 1982.
3. Simmons, B.J., R.R. Hanes, and F.S. Heming, Jr., "Dynamic Analyses of Test Platform," AIAA Paper No. 81-1816, August 1981.
4. Winter, George, and A.H. Nelson, Design of Concrete Structures, New York, McGraw-Hill Book Company (1979).
5. Broderson, Emil, "Stabilization of a Seismic Isolation Block, Inertial Instrument Testing," AIAA Paper No. 74-857, August 1974.
6. Harris, Cyril M., and Charles E. Crede, Shock and Vibration Handbook, Second Edition, McGraw-Hill Book Company (1976).

L MED
8