

AD-A136 201

ELECTRIC REMOTELY PILOTED VEHICLE (ERPV)(U) SUNDSTRAND  
AVIATION MECHANICAL UNIT ROCKFORD IL J O SMITH SEP 83  
ASD-TR-83-5014 F34601-80-G-0192

1/2

UNCLASSIFIED

F/G 10/3

NL

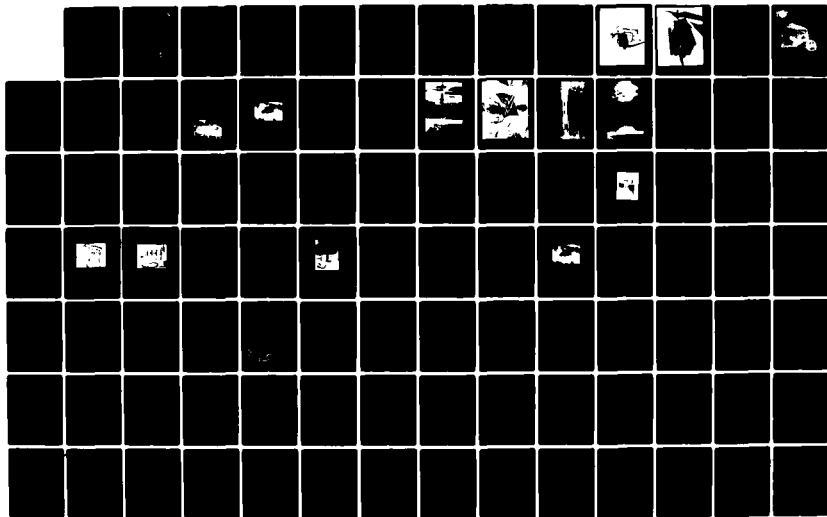

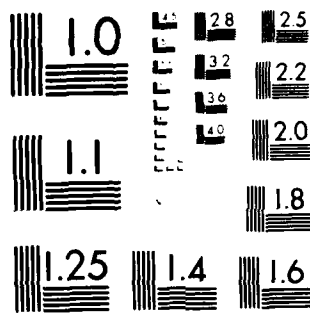

MICROCOPY RESOLUTION TEST CHART  
NATIONAL BUREAU OF STANDARDS-1963-A

ASD(TAB)-TR-83-5014

12

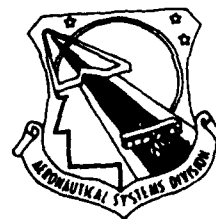

ELECTRIC REMOTELY PILOTED VEHICLE (ERPV)

John O. Smith  
Test Manager

AD-A136201

September 1983

Final Report for Period August 1980 to August 1982.

Approved for public release; distribution unlimited.

DEPUTY FOR TACTICAL SYSTEMS  
AERONAUTICAL SYSTEMS DIVISION  
AIR FORCE SYSTEMS COMMAND  
WRIGHT-PATTERSON AIR FORCE BASE, OHIO 45433

DTIC  
ELECTE  
DEC 21 1983  
S A

DTIC FILE COPY

83 12 20 181

NOTICE

When Government drawings, specifications, or other data are used for any purpose other than in connection with a definitely related Government procurement operation, the United States Government thereby incurs no responsibility nor any obligation whatsoever; and the fact that the government may have formulated, furnished, or in any way supplied the said drawings, specifications, or other data, is not to be regarded by implication or otherwise as in any manner licensing the holder or any other person or corporation, or conveying any rights or permission to manufacture use, or sell any patented invention that may in any way be related thereto.

This report has been reviewed by the Office of Public Affairs (ASD/PA) and is releasable to the National Technical Information Service (NTIS). At NTIS, it will be available to the general public, including foreign nations.

This technical report has been reviewed and is approved for publication.

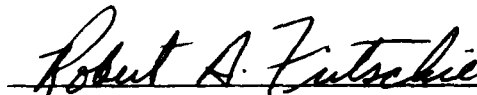
  
\_\_\_\_\_  
Robert A. Futschie  
Colonel, USAF  
Chief, Aerospace Power Division  
Asst Deputy for Tactical Systems

  
\_\_\_\_\_  
JAMES D. REAMS  
Chief, Aerospace Power Division  
Aero Propulsion Laboratory

FOR THE COMMANDER

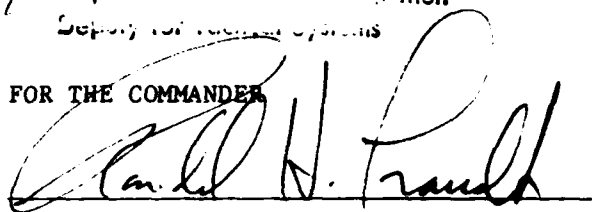
  
\_\_\_\_\_  
Ronald H. Traudt

RONALD H. TRAUDT,  
Colonel, USAF  
Asst Deputy for Tactical Systems

If your address has changed, if you wish to be removed from our mailing list, or if the addressee is no longer employed by your organization please notify ASD/TABT, WPAFB, OH 45433 to help us maintain a current mailing list.

Copies of this report should not be returned unless return is required by security considerations, contractual obligations, or notice on a specific document.

UNCLASSIFIED

SECURITY CLASSIFICATION OF THIS PAGE (When Data Entered)

REPORT DOCUMENTATION PAGE		READ INSTRUCTIONS BEFORE COMPLETING FORM
1. REPORT NUMBER ASD(TAB)-TR-83-5014	2. GOVT ACCESSION NO. <b>AD-A136201</b>	3. RECIPIENT'S CATALOG NUMBER
4. TITLE (and Subtitle) Electric Remotely Piloted Vehicle Report (U)	5. TYPE OF REPORT & PERIOD COVERED Final	
	6. PERFORMING ORG. REPORT NUMBER	
7. AUTHOR(s) JOHN O. SMITH CAPT MARY L. SHERMAN	8. CONTRACT OR GRANT NUMBER(s) F34601-80-G-0192/ F33601-80-C-0339	
9. PERFORMING ORGANIZATION NAME AND ADDRESS Sundstrand Aviation Mechanical (F34601-80-G-0192) 4747 Harrison Avenue Rockford, IL 61101	10. PROGRAM ELEMENT, PROJECT, TASK AREA & WORK UNIT NUMBERS PE 63739F	
11. CONTROLLING OFFICE NAME AND ADDRESS Aeronautical Systems Division ASD/TABT Wright-Patterson AFB, OH 45433	12. REPORT DATE September 1983	
	13. NUMBER OF PAGES 150	
14. MONITORING AGENCY NAME & ADDRESS (if different from Controlling Office)	15. SECURITY CLASS. (of this report) UNCLASSIFIED	
	15a. DECLASSIFICATION/DOWNGRADING SCHEDULE	
16. DISTRIBUTION STATEMENT (of this Report) Approved for public release; distribution unlimited.		
17. DISTRIBUTION STATEMENT (of the abstract entered in Block 20, if different from Report)		
18. SUPPLEMENTARY NOTES 9 & 11 Continuation: Honeywell, Inc. (F33601-80-C-0339) AFWAL Aerospace Power Division Defense Systems Division AFWAL/POOC Power Sources Center WPAFB, OH 45433 104 Rock Road Horsham, PA 19044		
19. KEY WORDS (Continue on reverse side if necessary and identify by block number) Lithium Thionyl Chloride Silver-Zinc Samarium Cobalt		
20. ABSTRACT (Continue on reverse side if necessary and identify by block number) Electric propulsion offers significant advantages over the present gasoline engine propulsion system on a Remotely Piloted Vehicle (RPV). The advantages are the result of technical advances in batteries, power transistors, permanent magnets and Control Methods. This program was a continuation of an exploratory development effort by the Air Force in electric propulsion for a mini-drone. This report covers the ground & flight test of an RPV using a lithium thionyl chloride battery powering a Samarium Cobalt brushless DC Motor.		

DD FORM 1473 EDITION OF 1 NOV 65 IS OBSOLETE

FORM 1 JAN 73

UNCLASSIFIED

SECURITY CLASSIFICATION OF THIS PAGE (When Data Entered)

PREFACE

This report, "Electric Remotely Piloted Vehicle Report" presents the results of an electrically propelled Remotely Piloted Vehicle development and flight testing.

The work was administered initially under the direction of the RPV Systems Program Office (ASD/TAR), WPAFB, OH. When the RPV Systems Program Office was terminated the direction was continued by the Deputy for Tactical Programs Integrations, Deputy for Tactical Systems, WPAFB, OH. The authors wish to thank Mr. Richard Marsh (AFWAL/POOC), The battery development engineer, Mr. Kenneth Bonnema (AFWAL/FIMS), the RPV pilot, and Mr. Leon Stratis (ASD/TAEA), the propulsion system engineer. Thanks are also extended to Honeywell Power Sources Center, Mr. Kurt F. Garoutte (battery engineer) and Mr Patrick Curran, Sundstrand Aviation for their valuable assistance and support.

Honeywell, Inc.- Contract Number F33601-80-C-0339

Sundstrand Aviation Mechanical - Contract Number F34601-80-G-0192

Program Element Number- PE63739F

Program Priority - 2-4

DTIC	
COPY	
INSPECTED	
3	
Distribution/	
Availability Codes	
Area and/or	
Special	
A1	

## TABLE OF CONTENTS

SECTION I	INTRODUCTION	
	1. Purpose of the Report	1
	2. Background	1
	3. ERPV Evaluation Program	1
SECTION II	TEST ARTICLES	2
	1. Description of Lithium Thionyl Chloride Battery	2
	2. Description of Samarium Cobalt Brushless DC Motor	2
	3. Description of XBQM-106 Mini-Drone	2
	4. Description of Yardney Silver Cell Battery	5
SECTION III	TEST FACILITIES AND EQUIPMENT/SET-UP	7
	1. Facilities and Equipment	7
	2. Test Set-up	9
SECTION IV	TEST RESULTS AND ANALYSIS	19
	1. Controller and Motor Performance Test	19
	2. 33 Cell Lithium Battery Ground Test	19
	3. Motor/Controller and Propeller High-Speed Ground Test	24
	4. Silver-Zinc Battery Powered Flight Test	24
	5. Lithium Thionyl Chloride Battery Flight Test	25
SECTION V	CONCLUSIONS	28

## LIST OF ILLUSTRATIONS

### FIGURE

1.	Honeywell Lithium Thionyl Chloride Battery	3
2.	Sundstrand Motor/Controller	4
3.	Yardney Silver-Zinc Battery	6
4.	Mini RPV Battery Cell Layout and Wiring Diagram	10
5.	Mini RPV Battery and Simulated Bulkhead Test Set-up	10
6.	Complete Mini RPV Ground Test Set-up Prior to Electrolyte Filling	11
7.	Motor/Controller and Propeller High-speed Ground Test	14
8.	Propeller High-speed Ground Test	14
9.	XBQM-106 Airframe prior to Installing Battery and Nose Cone	15
10.	Launch and Ground Station	17
11.	Flight Test with Silver-Zinc Battery at Wilmington Oh	17
12.	Flight Test at Wilmington Oh	17
13.	Lithium Thionyl Flight Test Set-up	18

## APPENDIXES

A.	High Rate Li/SOCL <sub>2</sub> RPV Battery Design and Performance	29
B.	Technical Summary of Mini-Drone Electrical Motor and Controller	47
C.	33 cell Mini RPV Battery Ground Test Data	54
D.	Electric RPV Mishap	90
E.	Lithium Thionyl Chloride Battery Flight Test Data	102
F.	ERPV Flight Test Plan	121
G.	ERPV Field Operations and Countdown Procedures	136

## APPENDIX FIGURES

A-1	Honeywell Model G3116A1 Basic Cell	31
A-2	Voltage and Temperature Versus Time	33
A-3	Voltage Versus Time of an RPV cell at 75°F	34
A-4	4 cell Submodule Test Hardware	36
A-5	112 volt Li/SOCL <sub>2</sub> Mini RPV Battery	37
A-6	Remote Activation System for Mini RPV Battery	39
A-7	Hydraulic clamp Assembly and Electrolyte reservoir	40
A-8	Quick Release Fill Plug (Front of Battery)	42
A-9	Complete Mini RPV Ground Test Set-up	44
A-10	Battery Voltage/Temperature Versus Time	45
B-1	Motor and Controller	50
B-2	End View of Motor	51
B-3	Rotor Position Sensing	51
B-4	Controller Block Diagram	51
B-5	Controller Model	52
B-6	Inverter Configuration	52
B-7	RPV Motor/Controller Data Reduction Program	53
B-8	Sundstrand Motor Test	53
B-9	Flight Package	53
B-10	Performance Parameters	53
B-11	Flight Operation	53

## SECTION I

### INTRODUCTION

#### 1. Purpose of the Report

The purpose of this report is to document the significant findings of the Electric Remotely Piloted Vehicle (ERPV) Test Program. This report explains how the demonstration program does prove that an electrically propelled Mini-Drone is feasible.

#### 2. Background

The conventional two-cycle gasoline engine which is to be used as the propulsion system for Mini-drone vehicles has certain inherent disadvantages. The long-term storage requirements for mini-drone weapon systems would require periodic system maintenance checks, as well as fueling/start-up operation prior to launch. The Electric Propulsion Validation program is aimed at developing an alternate propulsion system which will avoid these deficiencies. The electric propulsion system under test consisted of a high energy Lithium Thionyl Chloride (Li/SOCL<sub>2</sub>) Battery driving a Samarium Cobalt brushless DC motor through a solid-state controller. A Memorandum of Agreement (MOA) was established between AFWAL Propulsion Laboratory and ASD to procure the above battery. AFWAL was also under contract with Yardney Corporation to provide rechargeable (Silver Zinc) batteries. Honeywell Power Sources Center was placed under contract to design and develop a Li/SOCL<sub>2</sub> battery to provide the propulsion power for the XBQM-106 mini-drone. A contract was issued by ASD to Sundstrand Corporation to provide the Samarium Cobalt brushless DC motor. An MOA was also established with the Flight Dynamics Laboratory to integrate the battery and motor into an XBQM-106 mini-drone vehicle for flight evaluation.

#### 3. ERPV Evaluation Program

The test program was divided into five separate evaluation activities.

(a) Performance of controller and motor system external to test vehicles (bench test).

(b) 33 cell Lithium Thionyl Chloride battery fill and activation procedures and ground test (flight profile loads).

(c) Motor/controller and propeller high-speed ground test, using lead acid batteries, to evaluate the propulsion system.

(d) Vehicle performance data gathering flight tests using a Silver-Zinc battery.

(e) Vehicle full endurance flight test with a Lithium Thionyl Chloride battery.

## SECTION II

### TEST ARTICLES

#### 1. Description of Lithium Thionyl Chloride Battery.

The battery used in the ERPV test program consisted of 33 series connected prismatic cells which utilized an acidic electrolyte solution of (0.5M  $\text{LiAlCl}_4$  + 2.5M  $\text{AlCl}_3$ )  $\text{SOCl}_2$  containing a dissolved amount of monomeric iron phthalocyanine catalyst. Additional details are:

Terminal voltage- 105 VDC (at planned cruise condition loading)

Peak rate- 82 Amps (max climb rate)

Manually activated

Total weight, Structure and Wiring- 61.4 Lbs

Available energy- 4341 watt hours

Energy density- 70.7 W-hrs/lb

Endurance- 1.2 hrs (for planned mission)

Refer to Appendix A for additional information. Also see Figure 1.

#### 2. Description of Samarium Cobalt Brushless DC Motor.

A Samarium Cobalt brushless DC motor with a climb power of approximately 10 HP was used. The primary advantage of the Samarium Cobalt brushless DC motor is its increased energy efficiency. The heat produced during use is generated in the power transistors of the electronic commutator and in winding of the stator. This results in a smaller, lighter motor for the same energy output. Other details are:

Efficiency- 88%

Cruise Power- 4 HP

Weight- 26.8 lbs

Refer to Appendix B for additional information. Also see Figure 2.

#### 3. Description of XBQM-106.

This vehicle is the Remotely Piloted Vehicle developed by AFWAL and designated as XBQM-106. The basic vehicle consists of the airframe, power plant, avionics electrical system, and a remote flight control system. The construction is primarily of fiberglass with aluminum and wood hard-points and a foam filler. The power plant for the ERPV program was an electric motor. A 28 volt battery pack provided power for the flight control receiver, the telemetering transmitter, the encoder/decoder, all on-board instrumentation, the

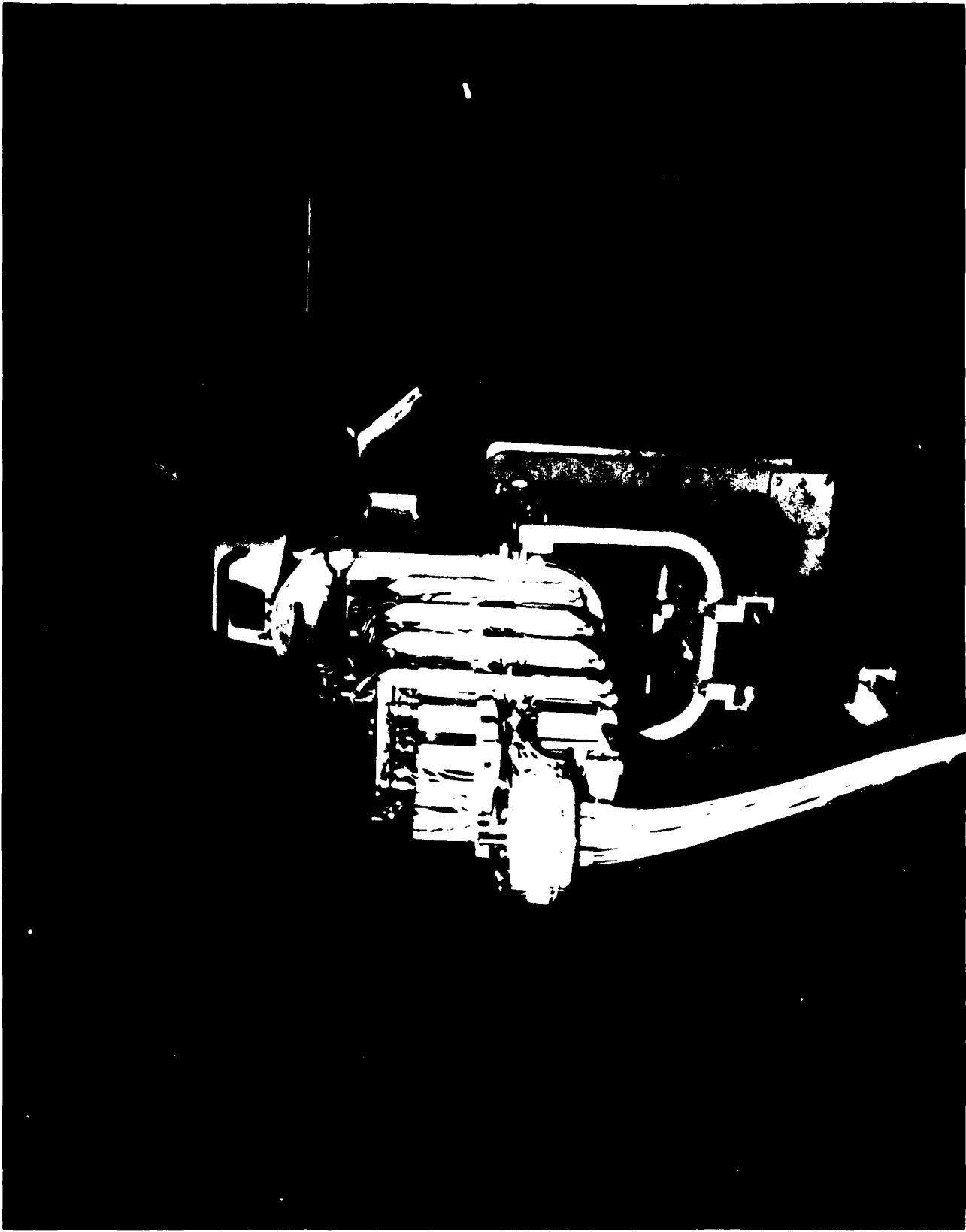

Figure 1. Honeywell Lithium Thionyl Chloride Battery



Figure 2. Sundstrand Motor/Controller

wing leveler and the flight control and throttle servo motors. This battery pack is assembled from 22 D-size nickel-cadmium rechargeable batteries, which are wired in series and taped together in a compact cluster in a fiberglass case. The flight controls are the conventional rudder (yaw), elevator (pitch), and ailerons (roll) driven by servos. A radio control (R/C) uplink flight control for manual mode is considered part of the XBQM-106 system. The gross weight of the XBQM-106 in the ERPV configuration was 180 pounds.

#### 4. Description of Yardney Silvercell Battery.

The Yardney Silvercell battery is a Silver-Zinc alkaline battery which differs considerably from the more familiar lead-acid battery and to a certain extent from other alkaline batteries such as nickel-cadmium, nickel-iron, etc.

This battery is an assembly of 74 series connected HR15 (11.5) DC-i cells restrained in a passivated aluminum battery case. The approximate overall dimensions of the battery are: 19.00 long x 6.00 wide x 11.00 high. The approximate weight of the battery is 51.8 pounds maximum. The silver battery was ballasted to equal the weight of the lithium battery to provide equivalent flight conditions. See Figure 3.

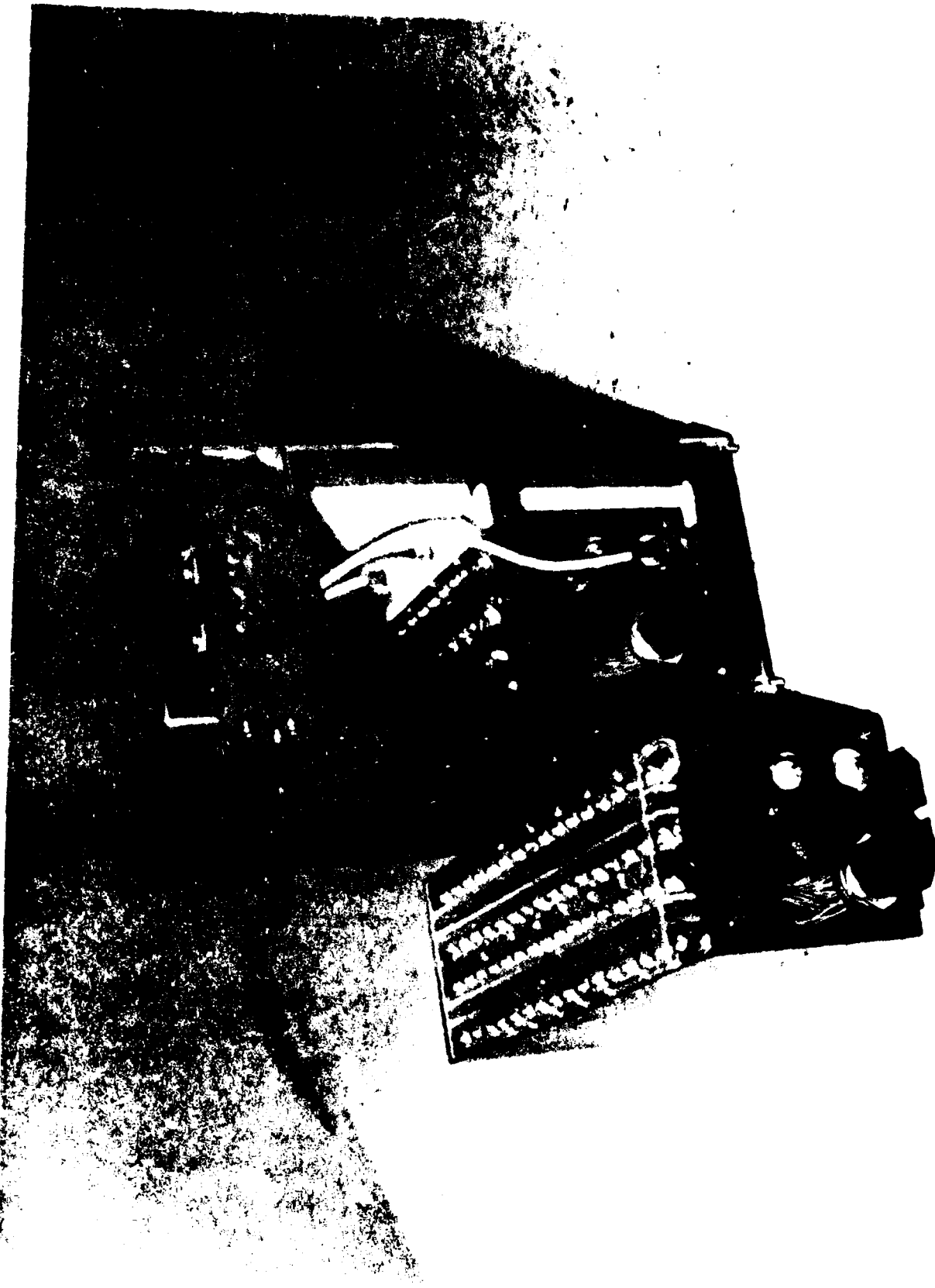

1935 Ford Sedan

SECTION III

TEST FACILITIES AND TEST EQUIPMENT

1. Facilities and Equipment

<u>Test Phase</u>	<u>Location</u>	<u>Equipment Involved</u>	<u>Test Nomenclature</u>	<u>Conducted By</u>
Phase 1	Sundstrand Corp	In house testing	Performance of Controller and motor system external to test vehicle	Sundstrand
Phase 2	Naval Weapons Support Center (NWS), Crane IN	<ul style="list-style-type: none"> <li>- XBQM-106 nose cone</li> <li>- Ground test</li> <li>- Electrolyte Solution</li> <li>- Exhaust blower</li> <li>- XBQM-106 bulkhead</li> <li>- Test monitoring equipment</li> <li>- Safety equipment</li> <li>- Communication equipment</li> </ul>	<ul style="list-style-type: none"> <li>33 cell Lithium Battery</li> <li>Ground Test</li> </ul>	NWSC & Honeywell
Phase 3	AFWAL, WPAFB OH	<ul style="list-style-type: none"> <li>- Tow vehicle</li> <li>- Electric motor with propeller</li> <li>- DC power source</li> <li>- Test platform</li> <li>- Test monitoring equipment</li> </ul>	Electric Motor Dynamic	AFWAL

Test Phase	Location	Equipment Involved	Test System Nature	Conducted by
Phase 4	Clinton County Airport, Wilmington, OH	<ul style="list-style-type: none"> <li>- XBQM-106</li> <li>- Electric Motor</li> <li>- Silver Zinc Battery</li> <li>- Launcher</li> <li>- Telemetry &amp; Drone Control Van</li> </ul>	Flight Test with Silver Zinc (Ag-Zn) Battery	AFWAL
Phase 5	Edlin AFB, FL	<ul style="list-style-type: none"> <li>- XBQM-106</li> <li>- Electric Motor</li> <li>- Silver Zinc Battery</li> <li>- Lithium Battery</li> <li>- Launcher</li> <li>- Telemetry Drone Control Van</li> <li>- Work platform</li> <li>- DC Power Generators</li> <li>- Fire truck</li> <li>- Airconditioning Cart</li> <li>- Flood lighting system for night operation</li> <li>- Dud retriever</li> <li>- C-4 explosive</li> <li>- Video and photo recording equipment</li> <li>- Safety equipment (chemical suits, flak suits, breathing apparatus, water bath, fire extinguishers)</li> <li>- Electrolyte solution</li> <li>- Battery activation equipment</li> <li>- Communication equipment</li> </ul>	Flight Test with Lithium Thiouyl Battery	Test Team directed by ASD

## 2. Test Set-up

### a. Performance of controller and motor-system external to vehicle.

The particular set-up used by the contractor to verify controller and motor system is not available; however, Appendix B should provide the necessary information required on the motor and controller.

### b. 33 Cell Lithium Battery Ground Test

Ground test of the Lithium Thionyl Battery was conducted at the Naval Weapons Support Center, Crane, Indiana. The battery was comprised of 33-series connected cells mounted on a simulated mini RPV bulkhead. The cells were packaged in two trays; the bottom tray contained seventeen cells and the upper tray contained sixteen cells. Each cell was wired such that individual cell temperatures and voltages could be monitored during the course of the test. The cells were wired and numbered as shown in Figure 4 below.

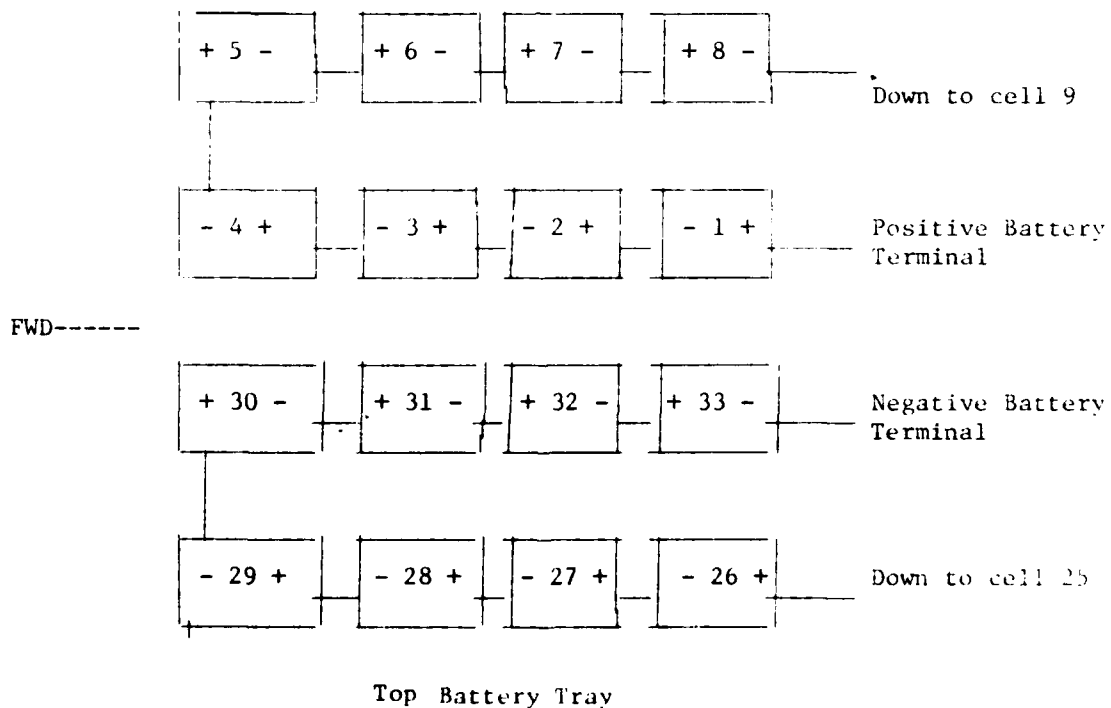

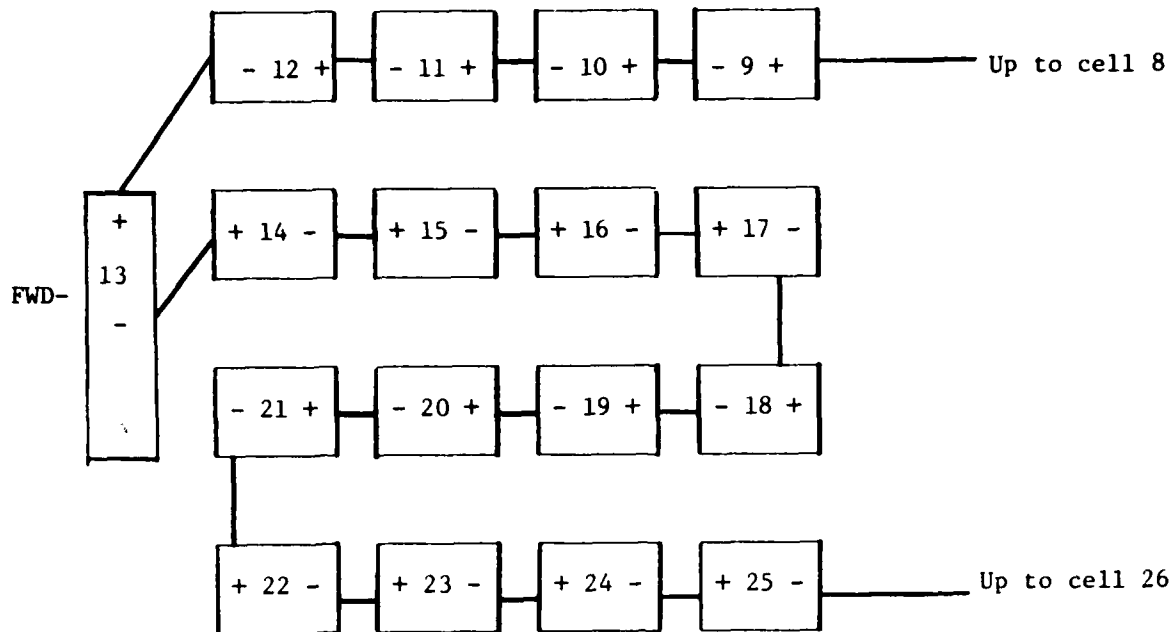

Lower Battery Tray

Figure 4. Mini RPV Battery Cell Layout and Wiring Diagram

A photograph of the complete battery mounted on the bulkhead, including the instrumentation leads is presented in Figure 5.



Figure 5. Mini RPV Battery and Simulated Bulkhead Test Set-up

Each cell contained a 1/8" Teflon fill tube connected to a central quick release fill plug mounted at the front of the battery. Protruding from the bottom of the fill plug was an umbilical cord consisting of 33 individual 1/8" O.D. Teflon tubes, each 28" long which were routed through the hydraulic clamp valve and connected to the bottom of the 33 cell electrolyte activator.

Figure 6 shows the battery prior to test with the nose cone installed and the activation gear connected with electrolyte ready to be transferred into the 33 cell activator from the electrolyte premix chamber.



Figure 6. Complete Mini RPV Ground Test Set-up Prior to Electrolyte Filling

Referring back to Figure 5 the battery was wired with an "ELCON" type connector designed to handle over 100 amps of current. This connector was installed behind the top tray of cells; it mated with terminals through the Mini RPV bulkhead and was connected to cells 1 and 33.

Other general battery characteristics were as follows:

Battery open-circuit voltage - 130-132 volts

Individual cell capacity

Designed to deliver: Nominal 40 Ahr

Theo. Lithium capacity: 76 Ahr

Electrolyte system: (0.5M LiAlCl<sub>4</sub> + 2.5M AlCl<sub>3</sub>) SOCl<sub>2</sub> + a proprietary catalyst

Quantity: 167 cc per cell or 5.51 liter for the battery

Battery Weight: Approximately 55 pounds

In addition to the above, the battery was capable of being remotely filled and activated prior to test and remotely disconnected from the Mini RPV after test for deactivation and disposal purposes.

The load profile utilized during the performance of this battery ground test was revised from that previously employed.

CRANE TEST BATTERY NO. 1  
LOAD PROFILE

<u>Time - Sec.</u>	<u>Current - Amp.</u>
26	19
20	72
8	40
15	64
108	70
cruise	36

NOTE: Readings were actual read-out from recorded "Load-Time" events during test.

Video tape monitoring of the complete test after the start of the activation procedure was accomplished and recorded on tape for future reference.

Ground Test of Battery No. 2 was conducted at NWSC on 15 Oct 81. Construction of this battery was similar to that of Battery No. 1 shown in Figures 5 and 6 except for the following changes:

Each cell fill tube was individually sealed within the umbilical cord valve by inserting small "O" rings into the system.

The complete activator system was raised.

Diodes (P/N 70H50A - International Rectifier) were added to each cell.

Electrolyte quantity utilized was 5700 cc's vs the 5676 cc's employed in the test of Battery No. 1.

c. Motor/Controller and Propeller High Speed Test (Cart Test)

The "Cart" is a ground mobile, dynamic simulator that is used to evaluate RPV propulsion systems (wind tunnel simulator). An RPV engine is mounted on a wheeled frame that is pushed down the runway by a van to duplicate flying velocities. The motor mount is set up with torque and thrust load cells. The engine is instrumented to read out RPM and for the electrical motor power input. The instrumentation and recording gear is carried in the van. To complete the simulation a dummy fuselage with clipped wings is fitted around the motor mount. When the cart is driven down a runway, complete propulsion analysis data can be achieved with the propeller operating in still air at flight speeds. The fact that the van and RPV use the same velocity range (60 to 90 MPH) makes this simple simulation possible.

d. Flight Test with Silver-Zinc (Ag-Zn) Battery

Tests were conducted at the Clinton County Airport, Wilmington, OH. The equipment required is listed in Section III. The launcher for the XBQM-106 was aligned with the active taxiway but off to the side. This set-up allowed for an early abort landing of the RPV. The intent of this test was to verify climbing profile; battery, motor and airplane compatibility and pilot proficiency with this configuration. See Figures 9 thru 12.

E. Flight Test with Lithium Thionyl Chloride Battery.

Major test equipment was set-up as per Figure 13. The Dud Retriever was required for remote handling of the battery after activation. Portable lights were required for night operations of activating the battery. Air conditioning cart was used to keep the battery temperature stable before launch. The fire truck was available for safety reasons.

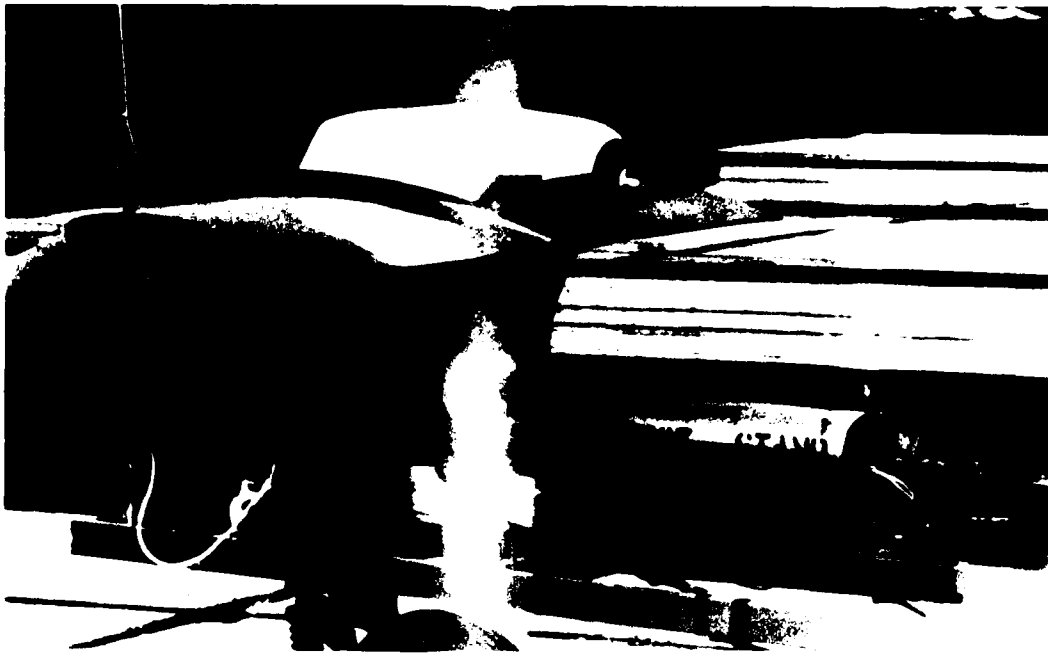

Figure 7. Motor/Controller and Propeller High-Speed Ground Test



Figure 8. Propeller High-Speed Ground Test

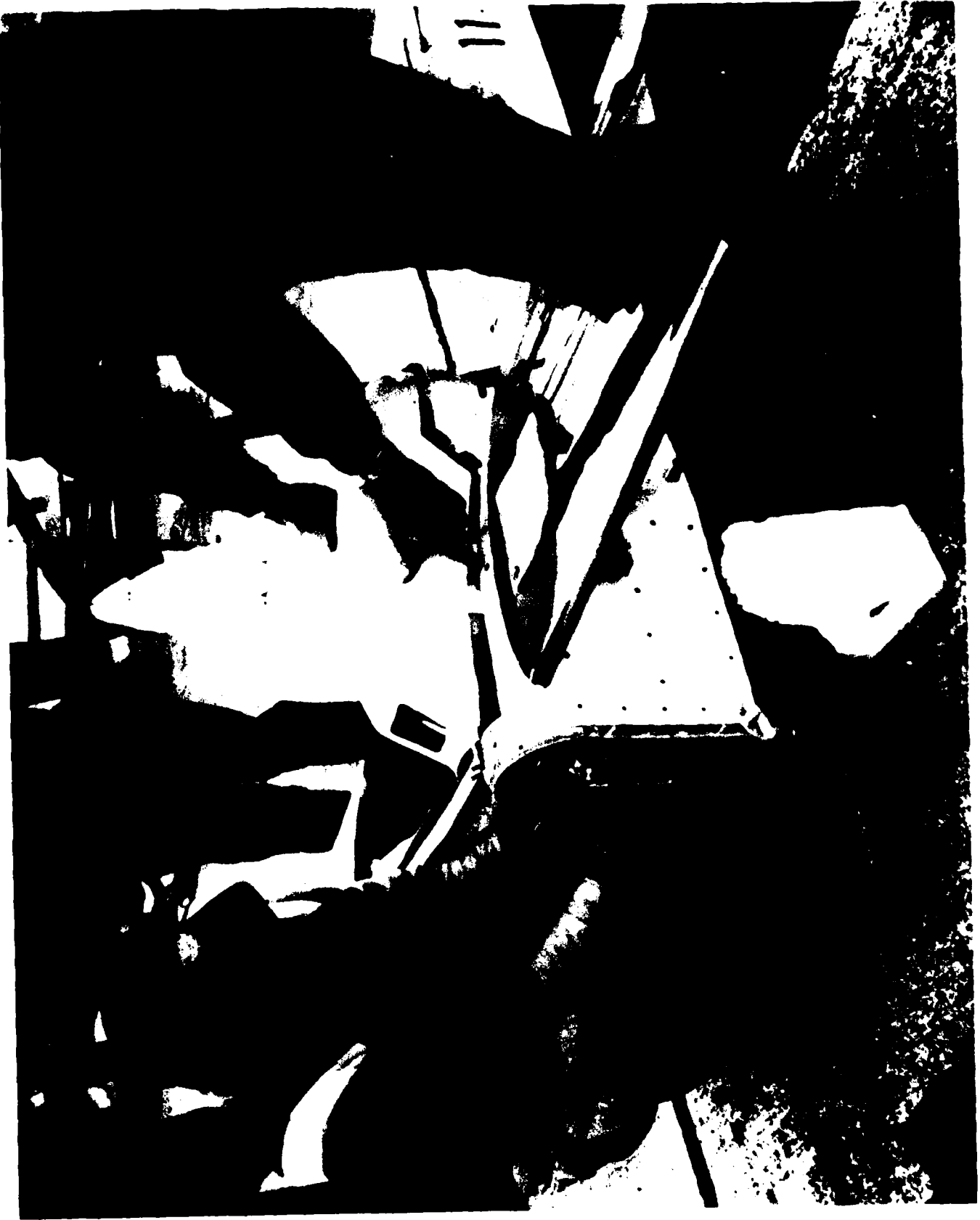

Figure 9. XBQM-106 Airframe Prior to Installing Battery and Nosecone



• • • • •  
Figure 10. Launcher and Ground Station

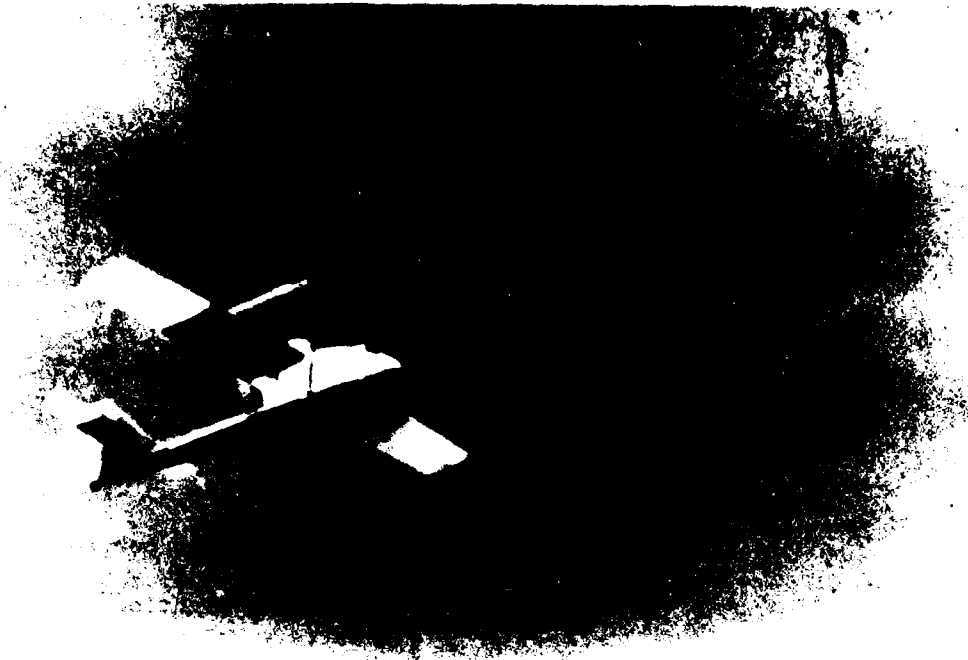

Figure 11. Flight Test with Silver-Zinc Battery at Wilmington OH



Figure 12. Flight Test at Wilmington OH

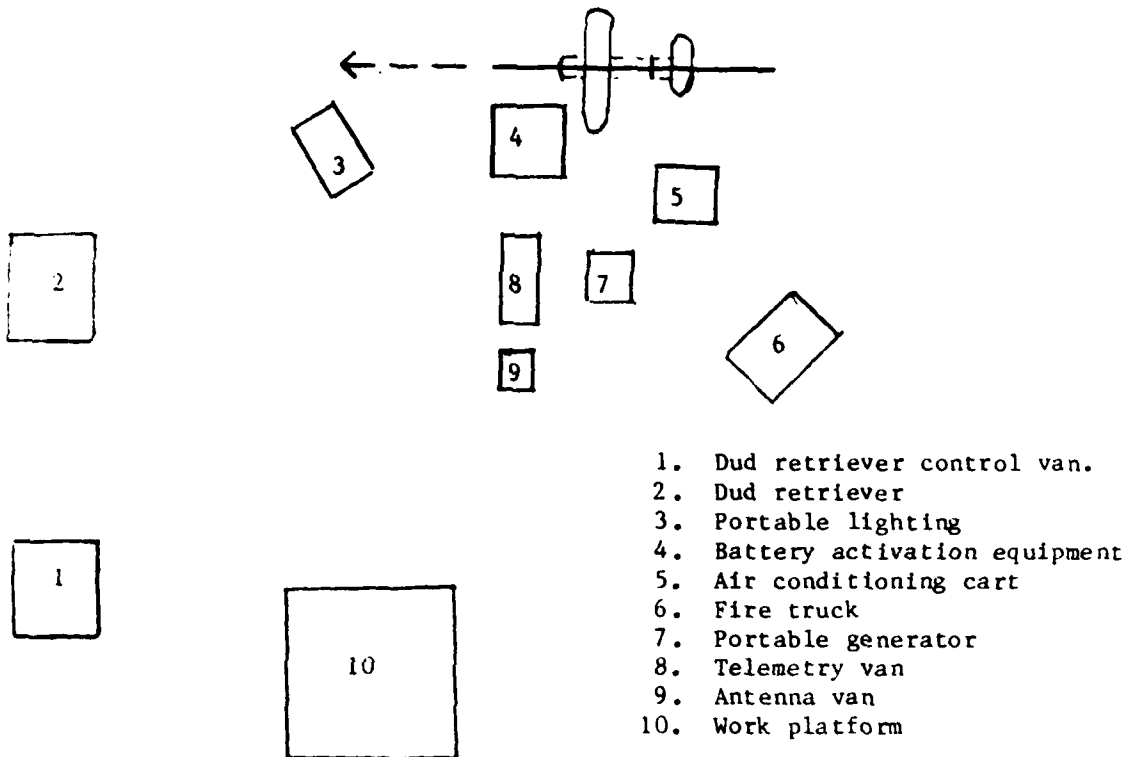

Figure 13. Lithium Thionyl Flight Test Set-up (Eglin AFB, FL)

## SECTION IV

### TEST RESULTS AND ANALYSIS

#### 1. Controller and Motor Performance

See Appendix B.

#### 2. 33-Cell Lithium Battery Ground Test

##### a. Battery Test No. 1 (18 Aug 81)

Battery activation did not progress as expected. Field observation showed that some of the teflon lines in the umbilical cord were not clearing of electrolyte as expected. Argon pressure driving the electrolyte was increased to 25 psig in an effort to correct the above problem. However, the incomplete transfer of the electrolyte to some of the cells was not able to be corrected. At this point in time, it was not known to what degree the above electrolyte fill problem had occurred, therefore, the battery was placed on the agreed upon load profile, after successfully activating the umbilical cord release system.

Two (2) cells, No. 4 and No. 13, showed depressed voltages during the battery discharge. Cell No. 4 went into early cell reversal which ultimately caused failure of the complete battery when it ruptured and burnt, causing other cells in the battery to fail via rupturing and burning.

Prior to Cell No. 4 going into reversal, however, the battery ran approximately 10 minutes against the load profile and then continued to run approximately an additional 3 minutes until battery failure due to its rupture.

Data showing cell voltages-vs-time are provided in Table 1. Cell No. 1 is on Channel No. 41 followed consecutively up to Channel No. 73 containing Cell No. 33. Examination of this data shows several cells (27, 28, 29, 30, 31, 32 and 33) showing early depressed voltages but eventually reaching the anticipated voltage levels. This is believed to be due to improper electrolyte filling.

Data showing cell temperatures-vs-time are provided in Table 2 Cell No. 1 is on Channel No. 0 followed consecutively up to Channel No. 32 containing Cell No. 33. Ambient air temperature near the battery is shown on Channel No. 33.

Examination of the electrolyte reservoir after the test confirmed that residual electrolyte remained in some of the reservoir cavities.

This test, although unsuccessful, showed that the battery was capable of providing the correct voltage and current levels against the specified load profile. It also demonstrated that the heat management techniques employed would provide proper cooling if cells were not allowed to go into reversal. Based on the above test results, it was agreed that a repeat of this test would be conducted with the following improvements to the electrolyte activation system/technique.

Table 1 Crane Test  
Single Cell Voltage Data

0-33 vs TIME  
41-73 vs TIME  
VOLTS

SCAN	09:35	09:37	09:39	09:41	09:44	09:46	09:48	09:50	09:53	09:55	09:57	09:59	
Cell 1	41	3.93	3.95	3.95	3.27	3.61	3.46	3.39	3.39	3.39	3.66	3.68	0.00
	42	3.94	3.96	3.96	3.33	3.62	3.54	3.41	3.41	3.41	3.66	3.66	0.03
	43	3.94	3.96	3.96	3.31	3.61	3.46	3.40	3.41	3.41	3.65	3.32	0.00
→	44	3.94	3.95	3.95	2.87	3.12	2.80	1.51	-0.70	-1.26	+0.40	0.00	0.00
	45	3.94	3.95	3.95	3.33	3.61	3.48	3.40	3.40	3.40	-0.39	-2.80	0.00
	46	3.95	3.96	3.96	3.31	3.61	3.49	3.40	3.40	3.40	3.61	2.34	0.00
	47	3.94	3.96	3.95	3.27	3.59	3.42	3.38	3.39	3.39	3.57	3.44	END DATA
	48	3.94	3.96	3.96	3.30	3.59	3.48	3.38	3.38	3.38	3.51	3.48	
	49	3.94	3.96	3.96	3.33	3.61	3.50	3.40	3.40	3.40	3.43	3.48	
	50	3.96	3.97	3.97	3.37	3.62	3.47	3.41	3.41	3.41	3.42	3.54	
	51	3.95	3.96	3.96	3.34	3.62	3.48	3.40	3.41	3.41	3.49	3.54	
	52	3.95	3.96	3.96	3.36	3.62	3.47	3.41	3.41	3.41	3.49	-0.63	
→	53	3.95	3.95	3.96	3.11	3.35	3.31	3.29	3.27	3.24	3.30	0.02	
	54	3.94	3.96	3.56	3.36	3.62	3.47	3.41	3.41	3.41	3.47	-0.13	
	55	3.95	3.96	3.51	3.40	3.63	3.53	3.42	3.42	3.42	3.42	-1.07	
	56	3.95	3.96	3.50	3.37	3.61	3.50	3.40	3.40	3.40	3.42	0.00	
	57	3.95	3.96	3.48	3.36	3.60	3.45	3.40	3.40	3.40	3.44	3.27	
	58	3.95	3.96	3.51	3.40	3.62	3.48	3.41	3.41	3.41	3.50	3.57	
	59	3.95	3.96	3.51	3.39	3.62	3.46	3.41	3.42	3.42	3.52	0.00	
	60	3.95	3.96	3.51	3.39	3.63	3.51	3.41	3.40	3.40	3.45	-0.05	
	61	3.95	3.96	3.52	3.40	3.63	3.45	3.41	3.42	3.43	3.54	-0.04	
	62	3.95	3.96	3.53	3.42	3.64	3.49	3.42	3.43	3.43	3.34	0.00	
	63	3.95	3.95	3.51	3.39	3.61	3.44	3.40	3.41	3.41	3.15	-0.05	
	64	3.95	3.96	3.52	3.41	3.61	3.45	3.40	3.40	3.40	3.66	0.03	
	65	3.95	3.96	3.51	3.38	3.61	3.43	3.39	3.40	3.40	3.67	0.04	
	66	3.95	3.96	3.51	3.39	3.60	3.45	3.40	3.40	3.40	3.67	-0.07	
	67	3.95	3.96	3.05	3.42	3.61	3.46	3.41	3.41	3.41	3.66	0.39	
	68	3.95	3.96	3.01	3.39	3.58	3.41	3.40	3.41	3.41	3.67	-0.21	
	69	3.95	3.96	3.05	3.42	3.62	3.45	3.42	3.42	3.41	3.67	0.00	
	70	3.95	3.96	3.11	3.44	3.64	3.45	3.42	3.43	3.44	3.67	0.23	
	71	3.95	3.96	3.08	3.42	3.62	3.42	3.41	3.41	3.40	3.67	0.00	
	72	3.96	3.96	3.10	3.44	3.61	3.44	3.40	3.40	3.39	3.67	-0.03	
	73	3.95	3.96	3.12	3.42	3.60	3.45	3.41	3.41	3.58	3.67	0.13	

LOADS  
1.9A  
3.6A  
3.6A  
EVENT?

20 → 36A →

0-33 vs TIME

41-73 vs TIME

'F →

Table 2 Crane Test  
Single Cell Temperature Data

SCAN	09:35	09:37	09:39	09:41	09:44	09:46	09:48	09:50	09:52	09:55	09:57	09:59	
CELL 1	0	66.9	68.5	68.9	70.7	78.2	85.2	93.0	93.9	93.2	131.8	117.4	646.4
	1	67.0	68.4	68.8	70.3	79.7	86.5	93.6	97.9	98.2	136.3	141.2	—
	2	67.5	69.4	70.0	72.0	84.7	97.3	112.5	116.6	116.6	167.6	154.4	853.4
4	3	67.5	68.5	69.0	72.0	85.6	92.7	99.0	110.3	132.6	193.5	104.9	—
	4	67.0	67.9	68.4	69.8	77.7	87.6	102.2	107.1	109.8	244.2	140.4	853.4
	5	67.5	68.8	69.3	70.8	80.7	93.0	107.3	114.0	114.7	236.9	190.0	650.5
	6	66.3	67.2	67.7	69.7	77.1	84.4	92.1	97.7	93.6	168.1	152.9	560.4
	7	66.5	67.1	67.5	68.8	74.0	77.7	81.8	83.2	83.5	149.1	117.7	576.7
	8	65.8	66.5	67.0	69.7	76.8	83.1	90.2	92.0	91.6	125.1	115.7	853.6
	9	66.3	67.1	67.3	69.0	77.4	84.8	95.7	98.8	98.7	137.6	145.6	725.4
	10	66.1	67.4	67.8	70.2	81.1	91.7	107.5	112.3	111.3	142.5	158.3	353.6
	11	66.8	67.7	68.1	70.5	81.2	93.3	105.7	113.1	114.4	141.0	427.7	854.1
	12	67.5	69.0	69.6	72.9	90.1	104.5	118.1	126.0	128.7	135.6	145.3	752.6
	13	67.2	68.3	68.8	71.4	83.1	94.6	112.5	119.5	120.0	133.2	764.1	353.6
	14	67.2	67.1	68.3	70.6	79.7	88.2	97.9	101.9	102.3	131.2	178.0	853.6
	15	67.3	67.8	68.2	69.9	76.7	82.5	89.3	91.2	91.3	132.2	158.0	349.5
	16	67.3	67.8	68.2	70.2	77.6	83.8	90.2	90.8	90.3	119.5	125.8	— 98.1 2000
	17	67.7	68.3	68.7	71.7	80.7	87.4	95.5	96.7	96.0	120.0	122.1	487.5
	18	67.3	67.8	68.2	71.1	79.3	85.4	92.8	94.2	94.1	128.9	853.7	670.2
	19	68.2	68.8	69.0	72.7	82.7	92.2	105.3	107.6	106.3	139.9	853.7	532.2
	20	63.4	67.0	67.5	71.2	81.9	93.1	107.5	111.4	112.2	114.6	114.0	658.9
	21	66.2	67.6	68.4	72.4	84.2	98.0	107.1	109.4	110.1	110.1	508.1	202.5
	22	66.4	67.4	68.0	71.8	81.8	90.0	97.1	98.2	98.0	138.3	656.9	723.1
	23	66.9	67.4	67.9	72.0	81.2	85.3	96.0	96.7	96.1	135.9	244.3	242.2
	24	67.7	68.0	68.4	73.2	83.0	91.6	98.5	98.3	97.3	120.2	137.4	302.6
	25	67.2	67.5	67.9	70.8	76.2	79.5	83.7	84.7	84.7	115.9	115.7	445.5
	26	67.3	67.5	67.9	70.6	76.7	80.6	85.2	86.4	86.4	148.3	155.2	510.0
	27	68.1	68.6	69.1	73.0	83.1	93.5	106.3	108.2	106.4	134.5	122.8	305.0
	28	68.1	68.5	69.1	73.3	84.0	96.5	112.0	116.0	118.3	111.8	90.8	375.2
	29	68.0	68.5	69.1	72.6	81.0	90.0	100.3	104.3	108.5	158.7	99.4	320.0
	30	66.5	67.2	67.6	74.2	87.7	103.3	118.1	119.1	117.5	175.0	171.3	220.0
	31	66.4	66.7	67.2	71.7	78.7	84.3	91.0	91.7	91.4	151.6	179.4	545.2
CELL 33	32	66.3	66.5	66.8	70.0	74.4	77.5	81.0	81.9	81.8	118.7	120.5	200.0
AMBIENT	33	70.5	71.5	71.2	73.6	71.7	73.2	73.1	75.0	70.5	72.4	78.1	500.0

TIME HEADINGS COUNTED AS ONE CHANNEL.

APPROX. 2 SEC. INTERVAL BETWEEN CHANNELS

- 0 Eliminate possible intercell argon leakage during the fill operation.
- 0 Elevate electrolyte reservoir with respect to the battery.
- 0 Implement practice runs at the test site prior to actual field use of the battery.
- 0 Prior to applying the load profile, continue to allow the cells to be properly soaked at 150 watt (1.2 amp) load for 4 to 5 minutes after battery activation is completed.
- 0 Add diodes to each cell to provide a greater margin of safety in terms of time-vs-cell temperature buildup if a cell were to go into a voltage reversal scenario.
- 0 Dry run the activation system in the lab to obtain volume delivery characteristics.

b. Battery Test No. 2 (15 Oct 81)

After activation, the battery was left on OCV approximately 2 minutes and then was placed on the light load (1.17A) until a total time of 10 minutes had elapsed. This was done to insure proper wetting of the cells prior to load application. The discharge profile associated with this test is basically the same as that of Battery Test No. 1. After the above 10 minutes had elapsed, the heavy load profile was automatically followed via load bank equipment.

The test performance was as expected with a total run time against the profile of 68 minutes being achieved after the application of the heavy load profile.

Excessive cell temperatures were not noted during the course of the test indicating that the heat management problem referred to earlier in this development program was under control during this test. The hottest cells were located in the bottom tray near the front of the battery (Cells No. 13 and No. 14) where maximum temperatures of approximately 142°F were recorded near the end of life. Battery voltages and currents were as expected throughout the run. Raw data showing time, battery voltage and discharge amperage for various points in the discharge cycle are provided in Table 3.

Table 3 Mini RPV Battery Test No. 2

Time, Voltage and Current Data

Time	Battery Voltage		Current (Amps)	
13:03:38	130.66	OCV	_____	
13:03:53	127.71	Light Load	2.060	
13:04:08	126.90		1.150	
13:08:08	126.97		1.145	
13:11:48	126.99		1.145	
13:11:53	116.58	Start of Profile	18.655	Start
13:12:12	116.93		18.67	End
13:12:18	100.1		75.54	Start
13:12:26	101.19		75.46	End
13:12:38	110.84	Approximately 68 Minutes	41.2	Start
13:12:42	111.41		41.34	End
13:12:46	105.75		64.55	Start
13:14:46	113.27		67.34	End
13:15:04	118.85		35.145	Start
13:19:24	114.43		34.0	
13:40:10	112.19		33.9	
13:58:06	111.05		33.0	
14:10:10	109.10		32.5	
14:15:10	106.51		31.7	
14:20:06	98.63	Cutoff at 99.0 Volts	29.4	End

Reviewing the above voltage data, it will be noted that a battery voltage near the cutoff (99.0 volts) was noted at the 75 amp load at the beginning of the profile. Battery voltage rapidly improved, however, as the run time progressed; at the end of the 67 amp load for instance. Approximately 3 minutes into the profile, battery voltage was 113.27 volts under load. Complete data in terms of battery voltage and current versus time is plotted in the first graph of Appendix C. The second graph of this Appendix provides average temperature and voltage data for all the cells plotted against time. These are followed by individual graphs of each cell showing cell voltage and temperature versus time.

This battery development program essentially had culminated with the satisfactory ground test of Battery No. 2, which had shown that the previously identified heat management problems, intrinsic to the basic electrolyte, could be solved at the system level. This was accomplished via using wider spacers surrounding each cell (up to 1/2" on all sides) and using ram air from the aircraft flight environment to cool the battery during use.

### 3. Motor/Controller and Propeller High-Speed Ground Test

Data results from the cart tests showed that the motor would perform properly in an aircraft installation and driven from a battery supply. The shaft data and thrust data showed that the propulsion system would successfully power the XBQM-106 aircraft through the planned mission at a gross weight of 180 pounds.

### 4. Silver-Zinc Battery Powered Flights (Wilmington, OH)

A number of test flights were conducted with the rechargeable Silver-Zinc battery. The objectives of the Silver-Zinc battery powered flights were:

a. Data and instrumentation flight. To obtain cruise and climb motor input data, including torque, RPM, voltage, temperature, rate of climb, speed and altitude to verify ground testing. This data was used to determine the optimum motor RPM at cruise in order to hold average input current to the value used in the ground lithium battery test.

b. Trial run of 1/2 mile diameter circular flight path and average input deviations.

c. Pilot proficiency in flying this configuration.

The initial flights at Wilmington indicated problems in vehicle trim/CG alignment and noise in telemetry data channels. The Flight Dynamics Laboratory did subsequent laboratory adjustments to correct the above problems.

Final tests indicated that the motor had potential thrust/torque to fly the vehicle, 1/2 mile diameter flight test could be flown and pilot could fly this configuration of the XBQM-106.

5. Lithium Thionyl Chloride Battery Flight Test, Eglin AFB, FL

a. The original intent to launch the ERPV in early Mar 82 resulted in a mishap using the Silver-Zinc battery. Refer to appendix D for accident report.

b. Prior to the Lithium Thionyl Chloride battery flight test, a dress rehearsal was conducted on 17 Jul 82 using the Silver-Zinc battery. Purpose of test was to practice count-down procedures and verify flight condition of XBQM-106. All data indicated the ERPV was ready for the Lithium Thionyl Chloride battery flight.

c. On 21 Jul 82 a 33-cell Li/SOCl<sub>2</sub> series-connected battery was activated, tested against the flight profile in Table 4 and disposed of at Eglin AFB, Florida.

The Lithium/SOCl<sub>2</sub> RPV battery appeared to be properly activated on the launcher with full electrolyte transfer to the cells having been achieved. Some difficulty was experienced removing the umbilical cord from the fill valve on the battery after the release lanyard was pulled; however, a minimum amount of electrolyte was lost during this process. After activation, the battery data appeared normal, i.e., OCV was slightly over 130 V. Runup of the motor showed the battery capable of delivering over 90 amps at 100 V. Slightly prior to launch battery safety vent appeared to be opening and closing, i.e., intermittent puffs of SOCl<sub>2</sub> electrolyte were exiting under the nose cone. Launch appeared normal. Again battery voltage, cell voltages and battery currents were normal.

Shortly after launch, two (2) cells dropped below the 2.5V minimum cutoff value. Cells being monitored for temperature rose to over 112°C and the battery was expelling large quantities of SOCl<sub>2</sub>. Based on the above abnormal characteristics, the vehicle was brought in as previously agreed in the test plan. Examination of the nose cone after retrieval showed the SOCl<sub>2</sub> electrolyte was being expelled through the battery safety vent. Examination of the activation setup after launch indicated some separation of the catalyst from the electrolyte in the residual SOCl<sub>2</sub> left in the fill apparatus tubing.

Since the test instrumentation did not provide complete profiles of the individual cell voltages and temperatures from activation until termination of the test, and since the battery was destroyed in place, a detailed failure analysis utilizing this data is not possible.

A definite assignable cause for the premature failure of the battery cannot be made without further development work; however, it is speculated that the failure could in some way be related to the entrance of moisture into the system. This would explain the rapid rise in cell pressure immediately after activation which caused the safety vent to start relieving cell pressure on the launcher. Loss of electrolyte through the vent would in turn cause higher than normal cell temperatures to exist. Loss of electrolyte would also eventually cause depressed cell voltages.

Visual examination of the unused electrolyte prepared for use in a second battery shows small particles in suspension and/or precipitation out of

ELECTRIC RPV  
XBQ-106 AIRFRAME  
LITHIUM BATTERY  
FLIGHT PROFILE 7S

PLANNED ENDURANCE TEST

TIME MIN.	THRUST POWER WATT	SHAFT POWER WATT	BATTERY POWER WATT	BATTERY ENERGY WATT/HR	ACCUM ENERGY KWH	APPROX. SHAFT RPM	AV/CY BATTERY POT. VOLT	BATTERY CURRENT AMP	BATTE ENERG A-HRS
1.25	--	--	1225 AV	25.5	0.026	VAR	101 F.L.	5-80	0.68
0.31	5083	7475	8306	42.9	0.068	6050	101.	82.2	1.11
0.13	2855	3614	4518	9.8	0.078	5000	111	40.7	1.19
2.2	4548	6405	7313	266	0.344	5760	111	65.9	3.61
62.6	2399	3030	3424	3572	3.92	4800	110.5	31.0	36.0

10% RESIDUAL  $\frac{0.43}{4.35}$

1. LAUNCH RAIL  
ENGINE RUN-UP

2. CLIMB TO 200 FT AGL  
650 FT/MIN 96 FT/SEC  
ON RADIUS TO CIRCLE

3. 90° TURN TO CIRCLE  
500 FT RAD. FLAT  
100 FT/SEC, -5.8° ELEV.

4. CLIMB ON 4500 FT DIA.  
CIRCLE 1/2 LAP TO 1200  
FT AGL 550 FT/MIN 96 FT/  
SEC

5. CRUISE ON 4500 FT DIA.  
CIR @1200 FT AGL  
67K-113 FT/SEC

CHANGES FROM PROFILE NO. 5S REV. A

- VEHICLE GROSS WEIGHT 180 lbs.
- ALL ENTRIES ADJUSTED TO REFLECT TEST DATA RESULTS, 22 Feb 82 Ag-Zn BATTERY FLIGHT TEST.

THE ABOVE DATA IS APPROXIMATE PROBABLE PERFORMANCE FIGURES FOR COMPARATIVE PURPOSES ONLY.

the solution. This phenomenon was also noted in the electrolyte utilized to activate the battery in question. It is possible that these particles are iron related, perhaps from the stainless steel closure plugs on top of the electrolyte bottle. It could also be speculated that the entrance of water into the electrolyte had caused the formation of  $\text{Al}(\text{OH})_3$ ; however, particle appearance is not that large or fluffy as typically expected with  $\text{Al}(\text{OH})_3$ .

If the particles are iron related, it is not clear how they could have affected battery performance, since the catalyst used also contains iron particles. Previous work has shown that successful cell and battery performance can be achieved with iron in the system.

At this point in time, a more likely cause of the battery malfunction would appear to be entrance of water into the system. As a result of test delays, considerable time had elapsed since the fabrication of the cells and the electrolyte. Both of the above are not truly hermetically sealed; considerable amounts of teflon tubing are employed in the battery, and the electrolyte bottle contained a teflon top cap as a compression seal. With time, it is possible that some amount of moisture had entered both of the above containers.

Another source of moisture, that may be more severe than those outlined above is related to the fact that the electrolyte was pre-chilled (to lower than ambient temperature) prior to use. When the electrolyte fill bottle cap was removed to add the catalyst, the outside temperature was approximately 73°F with very high relative humidity. The glass container housing the electrolyte was at approximately 55°F. In the 3- to 5-minute interval that this container was open for the addition of the catalyst, it may have been possible that enough moisture condensed on the interior surfaces of the glass electrolyte container to severely affect battery performance.

Moisture in the system could cause the formation of hydrogen gas which would pressurize the system causing the failure mode observed to occur. Additional development work would be required to confirm this speculated failure mode. See Appendix E for flight test data.

## SECTION V

### CONCLUSIONS

The results of this demonstration program are a first step in achieving electric propulsion in mini-drone vehicles. This test program is the first successful activation launch and flight of a Lithium Thionyl Chloride battery energizing an electric brushless DC motor. This is only the first step in developing electric propulsion. Mission requirements for mini-drones such as PAVE TIGER and LOCUST are three to four hours total flight time. The state-of-art is ready for this technology. The air vehicle, propeller and motor development need only be optimized to fit a power source. The lithium battery chemistry provides enough power for this mission, however, more testing and packaging of this chemistry needs to be developed. The power sources group of the Propulsion Lab have awarded a contract to GTE to do this testing and develop a light weight package made to fit a mini-drone.

The development of electric propulsion could be beneficial in the form of mini-drone Life Cycle Cost, increased storage life and reliability. The gasoline engine over the long storage life will require tuning, changing parts and run-ups to insure it will be available when needed. The electric motor on the other hand has little moving parts, needs no tuning and is readily available and reliable after being on the shelf a long time.

An electric propulsion system is ideal for the requirements of a mini-drone system. Further testing of this new technology is required before it is ready for system application and operational use.

## APPENDIX A

### HIGH RATE Li/SOCl<sub>2</sub> RPV BATTERY

#### Design and Performance

Kurt F. Garoutte, William C. Merz, David L. Chua and Narayan Doddapaneni  
Honeywell Power Sources Center  
Horsham, Pennsylvania 19044

#### INTRODUCTION

In the past, propulsion of Mini-Remote Piloted Vehicles (Mini RPV's) has been accomplished by using gasoline engines. Limited development work has been done using electric motors with silver zinc batteries. Primary concerns with gasoline engines are maintenance, logistics and shelf life. Weight constraints limited the silver zinc battery to flight times of 10-15 minutes. The challenge to the Aero Propulsion Laboratory (APL) Wright Patterson AFB was to determine within one year if a lithium battery could be obtained and demonstrated to provide over one hour of flight time under a Mini RPV launch and cruise load profile environment within demanding vehicle weight requirements.

The most attractive of the lithium systems was thionyl chloride although the battery specification requirements would demand state-of-the-art performance from the system.

Honeywell was placed under contract by APL to design and develop a multicell lithium thionyl chloride (Li/SOCl<sub>2</sub>) battery to provide the propulsion power for the Mini RPV's. Successful full scale ground testing of hardware demonstrated the feasibility of attaining the one-hour flight goal and weight requirements. This paper presents the unique Li/SOCl<sub>2</sub> electrochemical concept utilizing a catalyst, provides data obtained from single cell studies, describes the battery and activation system design, and summarizes overall battery performance.

The 130-volt (OCV) battery developed consists of thirty-three (33) series-connected prismatic cells (G116A1) which utilized an acidic electrolyte solution of (0.1M LiAlCl<sub>4</sub> + 2.5M AlCl<sub>3</sub>)SOCl<sub>2</sub> and contained a dissolved amount of monomeric iron phthalocyanine (FePc) catalyst.

The complete development cycle included four safety related design aspects at the single-cell level through the full-up battery to assure proper safety in handling and battery performance. First, the cells were designed to be shipped in a dry condition and activation achieved on site prior to flight. Second, the activation system was designed to operate remotely with provisions for uniform rapid electrolyte filling of the individual cells. Third, the intrinsic heat management concern at the cell level was resolved in the battery design by spacing the cells and employing ram air cooling characteristics from the aircraft flight environment. Fourth, the battery was designed with a quick disconnect feature from the RPV bulkhead for usage upon flight completion. The activation reservoir also had a quick disconnect with a self-sealing mechanism feature used prior to lift off. Both safety and weight benefited from this detachable activator concept.

The design, cell/battery performance and successful ground testing has demonstrated the feasibility of using the Li/SOCL<sub>2</sub> system for Mini RPV propulsion. Two more batteries are built and ready for Air Force flight verification testing.

#### SINGLE CELL DESIGN

The cells employed in the battery are prismatic cells and one such cell is shown in Figure A-1. The cell measures 10.8 cm (4.25 inches long) x 8.3 cm (3.25 inches high) x 3.2 cm (1.25 inches wide), and weighs 644 grams when filled with electrolyte. Isolation of the negative nickel terminal from the positive 316L stainless steel case is achieved through using Teflon-insulated Swagelok fitting. The cell has a wall thickness of 0.048 cm (0.019 inches) and it contains a 1/8" Swagelok elbow welded to the top cover for electrolyte activation which is accomplished via using 1/8" diameter Teflon tubing between the Swagelok elbow and the electrolyte reservoir. The cell top cover/case closure is fabricated via TIG welding after insertion of the electrode stack into the cell case.

#### Cell Components

The cell contains fifteen (15) cathodes, each measuring 10.16 cm x 6.35 cm

x 0.09 cm, and fourteen (14) full anodes plus two (2) half end anodes. The full anode measures 10.16 cm x 6.80 cm x 0.04 cm.

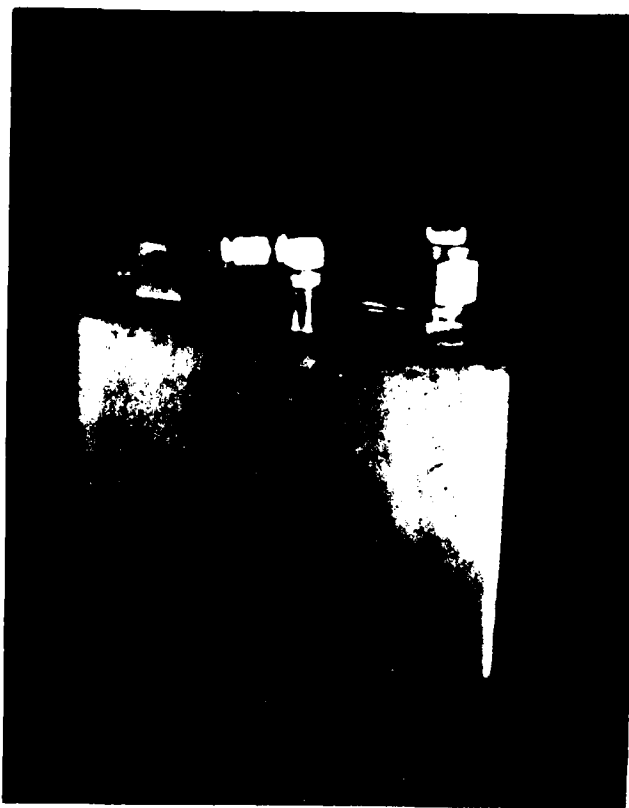

Figure 1-A. Honeywell Model G3116A1 cell

The cathode composition contains 95% Shawinigan carbon and 5% Teflon. Both positive and negative current-collector grids and leads use Nickel 200. Two layers of separators cut from 0.005 mil glass mat isolate each cathode from the adjoining anode.

Each cell accommodates 167 cc of (0.5M LiAlCl<sub>4</sub> + 2.5M AlCl<sub>3</sub>) SOCl<sub>2</sub> electrolyte. It also contains some dissolved amount of FePc catalyst to help increase the discharge rate capability.

### Cell Performance

The RPV load profile was designed around the maximum current handling capability on the cell. The discharge current went as high as 90 amps stepping downward during the initial 20 minutes of discharge time and culminating with a 33 amp current drain until a 3.0 volts per cell cutoff voltage was reached. The desired cell run time was a minimum of 1 hour. The discharge temperature of interest was in the +75°F to +110°F range.

Early experimental cell testing showed that cells activated at 110°F and if left on OCV or placed on immediate load would rupture or vent within 10-15 minutes. The problem is one of heat management and how it relates to the use of high AlCl<sub>3</sub> concentration (2.5 Molar). At the concentration level at 110°F, the chemical heat, which originates from the Li/SOCl<sub>2</sub> reaction, was found to be severe. After cell activation, typical cell data showed a gradual temperature rise on the cell case just prior to cell case rupture when thermal runaway was apparent. Thermal runaway was always accompanied by a small drop in OCV, i.e., on the order of 20 to 40 millivolts. This thermal runaway phenomenon under OCV condition is demonstrated in Figure A-2.

Limiting the cell operational temperature to ≤ +75°F and providing air flow around the external surface of the cell resulted in the elimination of the heat problem. Air flow rates of approximately 2500 RPM (28.4 MPH) through a 2-7/8" I.D. tube were found to be sufficient to control and stabilize cell case temperatures in both single-cell tests and 4-cell submodule tests. Figure A-3 provides typical voltage and temperature versus time plots for representative cells when discharged at room temperature against the current profile presented in this figure.

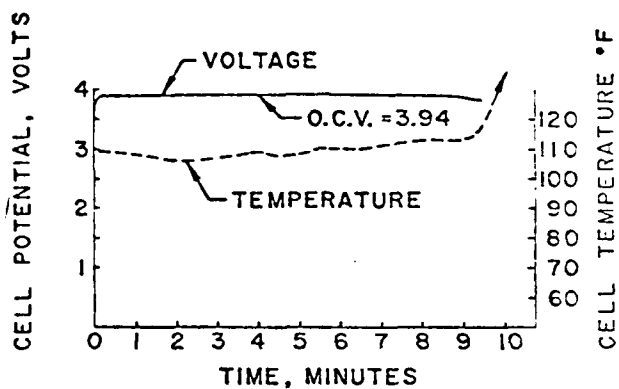
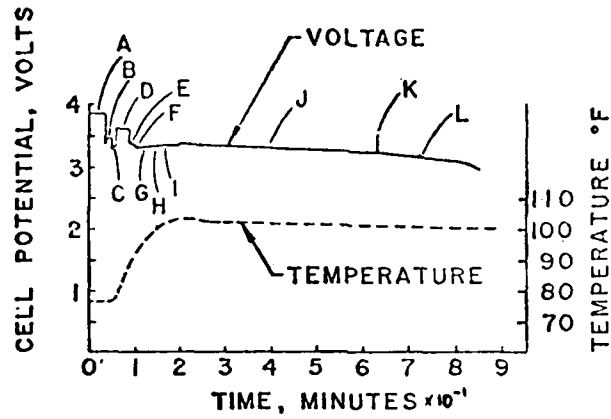

Figure A-2. Voltage and Temperature Versus Time. RPV cell test under OCV condition at 110°F.



	TIME (MIN)	CURRENT (AMP)	EQUIVALENT CD (mA/cm <sup>2</sup> )
A	0-4	1.2	0.6
B	4-5	43.9	22.7
C	5-6	78.8	40.7
D	6-9	28.0	14.5
E	9-10	69.7	36.0
F	10-11	62.0	32.0
G	11-13	53.2	27.5
H	13-16	49.0	25.3
I	16-19	42.0	21.7
J	19-63	33.0	17.0
K	63-63.3	1.2	0.6
L	63.3-70	33.0	17.0

3.0 VOLTS

Figure A-3. Voltage Versus Time of an RPV Cell at 75°F. An air flow technique was used to successfully manage heat problem.

In terms of a 4-cell submodule, it was found even with the aforementioned air flow, excessive heat build-up was occurring because of the tight packaging density in the battery. Agreement was reached with WPAFB personnel to make minor modifications to the Mini RPV aircraft nose cone shape, such that the cell-to-cell spacing could be increased from 0.10" to 0.50". In addition, the perforated aluminum trays (2) supporting the bottom of the cells were replaced with a more open aluminum structure. These design changes provided additional cooling and enabled the 4-cell submodule shown in Figure A-4 to undergo a successful discharge at room temperature. The confidence gained in this submodule test gave the go-ahead to develop and test a full-size, nominal 112-volt battery.

#### BATTERY HARDWARE DESIGN

Safety was a prime driver in the battery design. The overall battery design consisted of 33-series-connected cells packaged in two (2) trays. The bottom tray contained seventeen (17) cells and the upper tray contained sixteen (16) cells. The structural components of the battery were fabricated via welding 6061-T6 aluminum into an aircraft type truss arrangement to: 1) position the battery trays, 2) hold the cells in position while preventing cell expansion from internal pressure, 3) provide structural integrity to the battery in terms of surviving the flight environments, and 4) maintain adequate cell-to-cell spacing for heat removal.

A photograph of the complete battery mounted on a simulated aircraft bulkhead is presented in Figure A-5.

Some of the general design features relating to safety are as follows:

**Quick Battery Release** - A quick release pull pin located at the upper right of the photograph allows the battery to be rapidly removed from the aircraft bulkhead upon flight completion.

**Detachable Activation Mechanism** - A quick release fill plug located at the front of the battery allows the 33-tube umbilical cord that was attached to the reservoir to be ejected from the battery. This contributes to safe filling and allows the unnecessary reservoir weight to be left on the ground completing the battery activation.

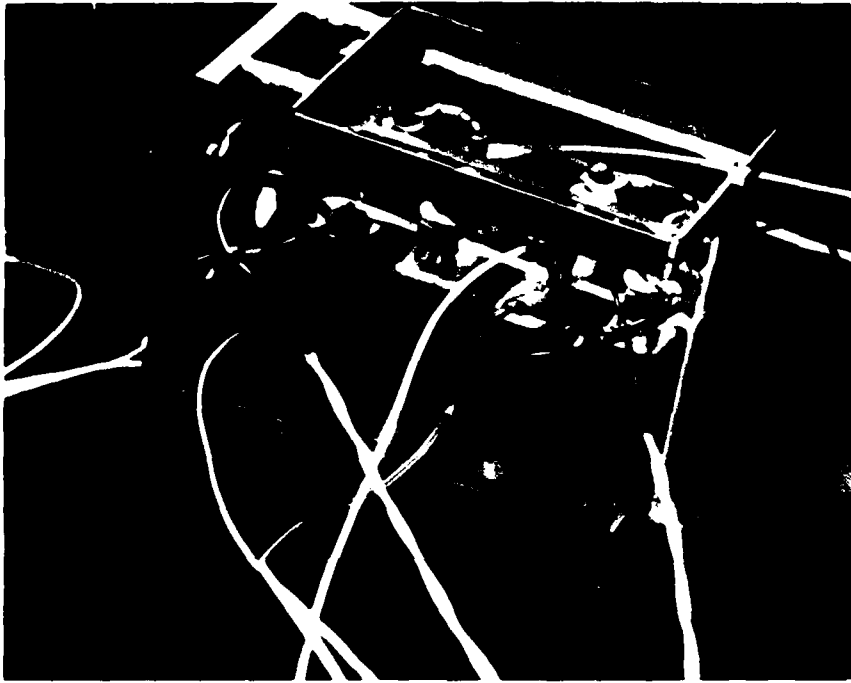

Figure A-6. Satellite Submodule Test Hardware

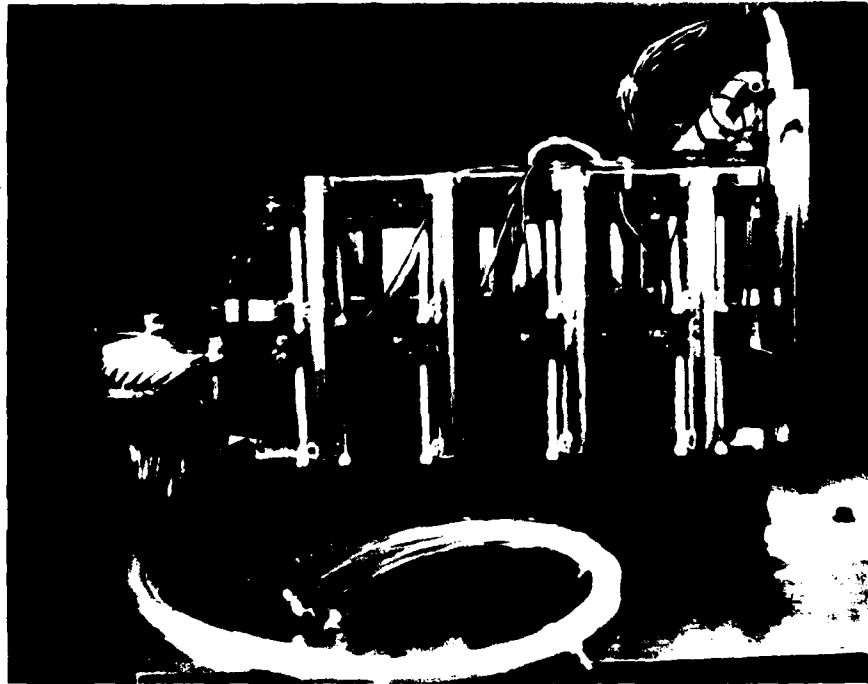

Figure A-5. A 11.2-Volt Li/SOCl<sub>2</sub> Mini RPV Battery  
Mounted on a Simulated Aircraft Bulkhead.

Diode Protection - Each cell is diode protected and contains a voltage tap to remotely monitor individual cell voltages during flight. The individual voltage monitorings allow advance warning to terminate the flight and the bypass diodes insure flight termination without occurrence of cell reversals.

Safety Vent - The battery contains a single setable safety vent allowing any cell to vent upon reaching pressures in excess of 45 PSIA.

Modified Electrical Connector - Electrical power is transmitted from the battery to the aircraft through an "ELCON" type connector which has been modified for disconnecting quickly at the aircraft bulkhead.

#### Activation System

A schematic of the battery activation system is provided in Figure A-6. The main functional components of the system are:

The spring loaded quick release fill plug which is lanyard operated and located on the battery.

The 33-cell activator containing individual compartments to separate the gross volume of electrolyte into smaller volumes applicable to each cell.

The remotely controlled electrically operated hydraulic clamp to simultaneously open and close all electrolyte lines to the cells.

Vacuum pump and argon supply.

Premixed gross electrolyte supply.

Electrolyte was introduced to each cell in the battery through a central quick release fill plug mounted at the front of the battery. Protruding from the bottom of this fill plug was an umbilical cord consisting of thirty-three (33) individual 1/8" O.D. Teflon tubes, each 28" long which were routed through a hydraulic clamp valve and connected to the bottom of the 33-cell electrolyte activator. Figure A-7 is a photograph showing external details of the hydraulic clamp assembly and the 33-cell activator.

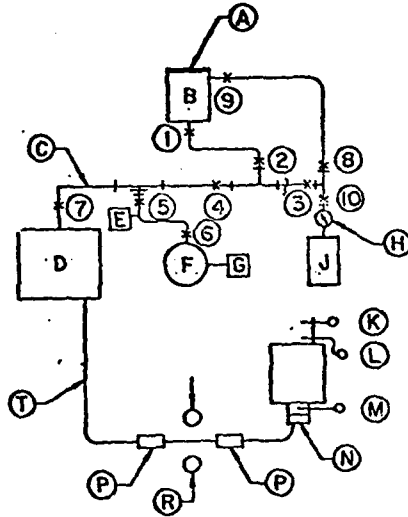

- |   |   |
|---|---|
| Ⓐ REMOVABLE COVER   | Ⓧ 1/8" SWAGLOCK VALVES                                      |
| ⓑ PREMIXED MEASURED AMOUNT OF ELECTROLYTE FOR TOTAL BATTERY | Ⓨ REMOTELY CONTROLLED ELECTRICALLY OPERATED HYDRAULIC CLAMP |
| ⓒ 1/8" TEFLON TUBING  | Ⓩ 1/8" TUBE SS-200-6 SWAGLOCK UNION (TYPICAL OF 33)         |
| ⓓ INDIVIDUAL COMPARTMENT 33 CELL ELECTROLYTE RESERVOIR      | ⓐ FULL LANYARD "A" NOSE RELEASE                             |
| ⓔ VECCO GAGE NO. 2  | ⓑ FULL LANYARD "B" BATTERY RELEASE                          |
| ⓕ VACUUM PUMP   | ⓓ FULL LANYARD "C" ELECTROLYTE VALVE                        |
| ⓖ VECCO GAGE NO. 1  | ⓔ SPRING LOADED QUICK DISCONNECT PLUG LANYARD OPERATED      |
| ⓗ PRESSURE REGULATOR  |   |
| ⓘ ARGON   |   |

Figure A-6 Remote Activation System for Mini RPV Battery.



Figure A-7. Hydraulic Clamp Assembly and Electrolyte Reservoir  
in the Electrolyte Activation System.

Functional details of the quick release fill plug are provided in Figure A-6. Basically, this valve maintained separate fill lines to each cell during activation. It also provided a common manifold volume such that each cell could access the common safety vent in case of adverse pressure conditions.

Battery Performance

The design and performance characteristics of this battery are:

Battery open-circuit voltage: 130-132 volts

Cell Capacity:

- Designed to deliver: Nominal 40 Ahr
- Theo. lithium capacity: 76 Ahr

Electrolyte System: (0.5M LiAlCl<sub>4</sub> + 2.5M AlCl<sub>3</sub>).SOCl<sub>2</sub> + FePc catalyst

- Quantity: 167 cc per cell or 5.51 liters for the battery

Battery Weight: Approximately 60 pounds

Life: One (1) hour minimum under a specified load profile ranging from 10 mA/cm<sup>2</sup> to 40 mA/cm<sup>2</sup>.

A functional ground test of the complete battery and activation system was conducted against the required load profile. Data presented in the following table summarizes the battery performance during this test.

Time (Seconds)	Battery Voltage	Current	Current Density
	Range	Amps	mA/cm <sup>2</sup>
180	130.7	OCV	-
420	127.7 - 126.9	1.15	0.6
25	116.9 - 116.6	18.6	9.6
20	101.2 - 100.1	75.5	39.0
8	111.4 - 110.8	41.3	21.3
126	113.3 - 105.8	67.3	34.8
65 minutes	118.8 - 100.0	33.0	17.1

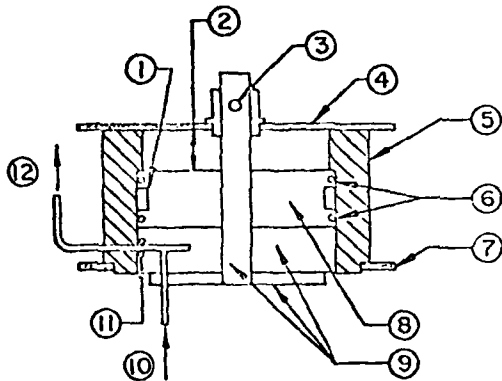

- ① COMMON ELECTROLYTE AND SAFETY VENT MANIFOLD
- ② COMPRESSION SPRING LOADING BETWEEN MANIFOLD VALVE DISK AND TOP COVER
- ③ ACTIVATOR PULL LANYARD
- ④ TOP COVER
- ⑤ TEFLON VALVE BODY
- ⑥ PARKER "O" RINGS P/N 2-15-V-747
- ⑦ BOTTOM COVER
- ⑧ MANIFOLD VALVE DISK
- ⑨ FILL VALVE DISK AND STEM ASSEMBLY
- ⑩ FILL LINES TO ELECTROLYTE ACTIVATOR TYP OF 33
- ⑪ PARKER INDIVIDUAL "O" RINGS P/N 2-004-V-747 TYP OF 34
- ⑫ TO CELL FILL LINES TYP OF 33

Figure A-8 Quick-Release Fill Plug Located at the Front of the Battery. The unit allowed the individual fill lines to be detached from the battery after completing the activation.

A load bank and switchgear constantly maintained the battery amperage near the levels shown in the above test data. Battery voltage varied throughout the range shown. In general, voltage increased from the lower value shown to the upper value within each segment of the profile as time progressed.

Figure A-9 is a photograph depicting the complete Mine RPV ground test set up prior to electrolyte filling. The photograph shows the 1) air cooling inlet duct on top of the aircraft nose cone housing, 2) the large cooling fan duct to provide simulated flight air flow, and 3) the electrolyte activation system with the electrolyte housed in the glass premix container.

During the test, stable cell temperatures were noted throughout the battery discharge cycle indicating that the aforementioned heat management problem had been satisfactorily solved.

Plots of battery voltage and temperature are shown in Figure A-10. The graph shows that during the higher rate variable portion of the load profile, the rate of temperature increase was approximately  $3^{\circ}$  F per minute. This equates to total temperature rise of approximately 30 F in this initial 10 minutes interval. An equilibrium temperature of approximately 96 F was maintained throughout the remainder of the test at the 33-amp discharge rate (i.e.,  $17.1 \text{ mA/cm}^2$ ).

#### SUMMARY

High rate  $\text{Li/SOCl}_2$  batteries can deliver satisfactory performance for applications such as providing propulsion power for Mini RPV's. The capability was demonstrated in hardware consisting of 33-series-connected prismatic cells utilizing a modified acidic electrolyte solution containing a catalyst.

Steady-state rate equivalent to  $17.0 \text{ mA/cm}^2$  for periods of over 40 minutes were demonstrated. Higher rates of up to  $40.0 \text{ mA/cm}^2$  were successfully achieved for shorter periods (i.e., 1 to 2 minutes). Observed battery voltages were 130 to 132 volts at OCV and a nominal 112 volts at the  $17.0 \text{ mA/cm}^2$  steady-state rate. A total battery run time of over one (1) hour (68 minutes) was demonstrated against the required performance profile. In order to accomplish the above, it was necessary to incorporate a sound heat management approach at the battery and

system levels to overcome the intrinsic heat generation problem associated with the use of acidic electrolyte.

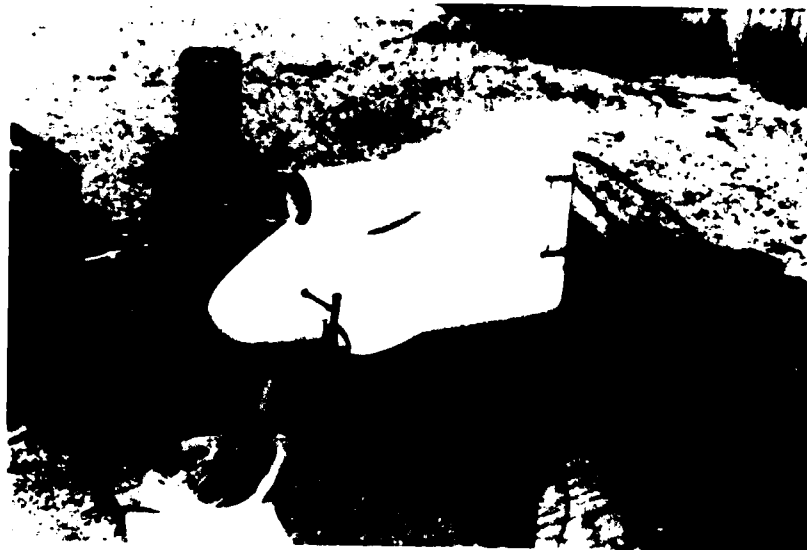

Figure A-9. Complete Mini RPV Ground Test Set-Up.

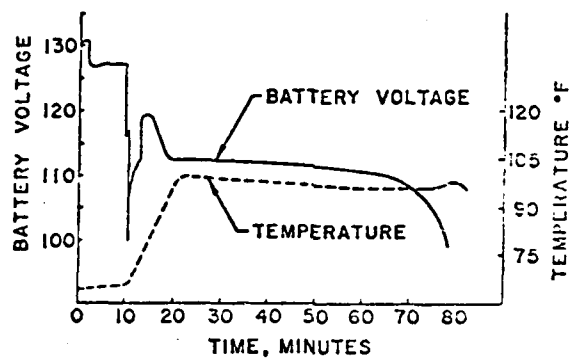

Figure A-10. Battery Voltage/Temperature Versus Time. This successful simulated flight performance led to the builds of two batteries for actual flight verifications.

Hardware items developed in the program included a remotely operated detachable activation system, which allowed simultaneous and uniform activation of all thirty-three (33) cells, such that a total active battery weight of approximately 60 pounds was maintained.

The development program has culminated with satisfactory ground testing the battery design. Additional battery hardware have been fabricated and are awaiting actual activation and flight test demonstrations.

#### ACKNOWLEDGEMENTS

This work was performed under Contracts F33601-80-C-0339 and F33601-80-C-0193 with Wright Patterson Air Force Base. The authors acknowledge the valuable guidance and assistance provided by numerous personnel from that facility.

APPENDIX B

Technical Summary of Mini RPV  
Electrical Motor and Controller

## A SAMARIUM COBALT MOTOR-CONTROLLER FOR MINI-RPV PROPULSION

Patrick Curran, Product Manager,  
Advanced Technology Development  
Dennis Faulkner, Group Engineer, Electrical Design

Sundstrand Corporation, 4747 Harrison Avenue,  
Rockford, IL.

### ABSTRACT:

This paper presents a brief summary of a program that was undertaken to develop a rare earth permanent magnet motor and controller to serve as the propulsion system for the first flight of an electrically powered Air Force XBQM-106 remotely piloted vehicle (RPV).

The paper discusses the aspects of the propulsion system, and presents the salient design features of the motor and controller. The performance data that was obtained from the development tests is presented, as is the data that was gained from the flight tests during the demonstration phase of the program. In summarizing the results of the demonstration flight tests, several of the vehicle performance aspects unique to electrical propulsion systems are also discussed.

### INTRODUCTION

Recent studies have indicated that rare earth permanent magnet motors show promise as propulsion systems for future applications of mini-remotely piloted vehicles (RPVs). Sundstrand Corporation, in cooperation with the Air Force, has developed an energy efficient Samarium Cobalt motor and controller to demonstrate the feasibility of an electrical propulsion system for mini-RPVs.

The program objective of demonstrating an electrical propulsion system for mini-RPVs was accomplished by coupling the Sundstrand designed motor-controller with a battery pack in an Air Force XBQM-106 RPV. The program plan called for several flight demonstrations with a silver zinc battery pack, followed by a one hour flight demonstration using a lithium thionyl chloride battery.

The schedule requirements of the program dictated that the design of the motor-controller be completed in a timely manner. The motor-controller was designed, assembled, tested, and delivered to the Air Force for their evaluation in less than eight months. The scope of the Air Force evaluation included several static bench tests, as well as electromagnetic interference (EMI) tests to insure that the motor-controller would not interfere with the telemetry signals of the RPV while in flight. Dynamic tests were also performed to determine the characteristics of the motor-controller at simulated flight speeds.

The specifications for the design of the motor-controller were provided by the Aeronautical Systems Division, Wright-Patterson Air Force Base. Since the XBQM-106 RPV has had many hours of operation with gasoline engines as the

propulsion system, this data was used as a basis for establishing the performance parameters of the Sundstrand electric motor-controller. The design specifications are listed here:

Input voltage: 105 VDC nominal no load  
Input Control Signal: 0-5 VDC  
Motor HP: 10.5 HP maximum, 5-6 HP continuous  
Motor Speed: Variable, 6700 rpm maximum  
Maximum Torque: 108 in-lbs  
Bearing thrust load: 75 lbs.  
Temperature of mounting surface: 140°F  
Maximum ambient temperature: 120°F  
Operating Envelope: 0 - 1500 ft

### SYSTEM DISCUSSION

A block diagram of the system is shown in Figure 1. The two major components of this system are the motor and the controller, with the controller further subdivided into the inverter and the motor control electronics. DC power from a battery is converted to a three phase output to drive the motor, with the inverter switching, and thus the three phase output frequency, being a function of rotor position feedback. Output speed is maintained within two percent of the input speed command by a closed loop speed control. This control varies the voltage applied to the motor by pulse width modulation of the output waveform. A current sense is provided on each output phase to produce a current limit used to protect the inverter transistors.

#### Motor

The motor is a brushless DC design using Samarium Cobalt permanent magnets in the rotor and three windings in the stator. The magnet polarities are radial and are bonded to the eight flat surfaces of the high permeability rotor hub creating an 8-pole magnetic rotor structure. The stator contains 39 slots with the coil windings connected in a three-phase wye configuration (thirteen slots being allocated to each phase). An end view of the motor is shown in Figure 2.

Commutation is achieved with an assembly consisting of a four lobed metal vane and three non-contact Hall-effect sensors (Figure 3). The vane is attached to the motor shaft with a fixed relationship to the rotor magnets. The position sensors are placed 120 degrees apart and respond to a flux density change when the metal vane passes through a built-in gap. A forty-eight tooth gear is also attached to the rotor and functions as a target for a magnetic pickup (MPU). This MPU provides a signal which is synchronized to the rotor position.

vane and used for speed feedback, pulse width modulation, and phase advance

Computer simulations employing digital techniques were used extensively in the process of designing the motor. The computer simulations were based on information gained from a literature search pertaining to numerical simulations of brushless DC motors. The information was adapted and modified by Sundstrand for this particular application, and the resulting simulations were used to predict the dynamic instantaneous performance of the motor. The simulations were later verified during the development tests of the motor.

#### Controller

A block diagram of the major controller functions is shown in Figure 6-4. As with the motor, a computer simulation of the controller was developed to model the controller. The control system model is shown in Figure 6-5.

Prior to resolving the final design configuration of the controller, a trade study was performed to determine the benefits of using either a voltage source or current source inverter system. The voltage source controller design was chosen for the following reasons:

- A voltage source system would limit voltage transients (spikes) which could overstress and cause transistors to fail.
- Fewer power switches would be required with the voltage source approach, since control is provided by pulse width modulation of the inverter switches.
- The voltage source approach has a higher calculated (predicted) efficiency than the current source approach (primarily because of fewer components).

A simplified schematic of the inverter is shown in Figure 6-4. Each power switch consists of two 100 amp, 200 volt transistors connected in parallel. Salient features of the control system are given here:

- Voltage Control - Voltage is controlled by pulse width modulation (PWM) of the inverter power switches. When the output speed is below forty-five percent of full speed (6700 rpm), the frequency of the PWM pulses is controlled by a fixed frequency oscillator. Above forty-five percent, the MPU signal from the motor sets the PWM pulse rate frequency and produces twelve PWM pulses per electrical cycle.
- 120 degrees Inverter Switch Control - Each power switch is on for only 120 degrees per electrical cycle. This means that at any one time a maximum of two switches can be on (one top switch and one bottom switch). Also, there is 60 degrees (electrical) between the on conditions for a top and bottom switch in a single leg (phase).
- Speed Feedback - A speed loop is provided to maintain actual speed within two percent of command speed.
- Current Limit - Motor current in each phase is sensed using a non-contact Hall effect current sensor. Each sensor produces a voltage proportional to current which is used to turn off all the upper inverter switches when a current of 125 amps is exceeded. The switches are re-enabled when the current drops below 100 amps.

- Phase Advance - To increase efficiency and to achieve the high speed at high power design points, switch turn-on is advanced in proportion to the speed of the motor when the motor exceeds eighty percent of maximum design speed.

#### SYSTEM TESTS

Development tests on the completed unit verified that the motor/controller system met or exceeded the stated design goals. Tabulation of test data is given in Figure 6-7 and a plot of efficiency versus torque is shown in Figure 6-8. The intended load for this system is a propeller which, in still air, approximately produces the torques given in the table for the given speeds. Normal operating speeds are above 4000 rpm. The measured efficiency in the normal operating range of the system is between eighty-five percent and eighty-seven percent.

#### PACKAGING

The controller and motor were packaged for flight as shown in Figure 6-9. The packaged unit weight is 26.7 lbs. with dimensions of 18.125 x 5.75 x 7.

Cooling for the unit is by ram air which flows first through the controller and then through the motor. The power electronics are mounted on heat sinks to enhance the heat transfer, and the motor has channels between the stator and the housing to allow for air flow passages to remove the heat from the motor. The stator cooling channels are effective since most of the heat developed in the motor is due to losses in the stator; losses in the rotor assembly are minimal because of the highly efficient Samarium Cobalt rotor.

#### FLIGHT TEST RESULTS

Four flights of the XBQM-106 RPV were made during the initial phase of the demonstration program. The initial four flights that are discussed in this section were flown using a silver zinc battery pack. Additional flights utilizing the silver zinc battery are planned, as is a flight with a lithium thionyl battery.

The primary purpose of the first flight was to familiarize the RPV pilot with the handling characteristics of the vehicle. One of the unique handling features of the RPV with this electric propulsion system was the slight lag in airspeed response that was experienced when a lower motor speed was commanded. This characteristic can partially be explained by noting that the installed electric motor-controller resulted in a configuration that was aerodynamically cleaner than the same vehicle with a conventional gasoline engine. The inherent characteristics of the electrical motor also contributed to the vehicle's slow aerodynamic response to a reduced speed command from the pilot. After the motor-controller receives a command to reduce its rpm, the propeller essentially windmills until the speed of the vehicle is reduced to the correct level. This windmilling phenomenon is not seen in the typical gasoline engine because in the gasoline engine the propeller creates drag on the vehicle as the compression from the engine holds the propeller at a given rpm. The windmilling characteristic of the electrical propulsion system eliminates this additional drag. The windmilling phenomena could have been avoided by

incorporating power regeneration into the design of the controller; however, since the lithium battery was unable to accept regenerative power this feature was not designed into the Sundstrand unit.

Another interesting feature of the electric motor-controller unit is its ability to control the speed (i.e. rpm) within two percent of a selected value. The 0-5 volt input signal corresponds to given rpm values rather than throttle settings as found in gasoline powered RPVs. This feature enables the pilot to hold the motor at a given rpm when a maneuver requiring additional power is entered, without adjusting the speed command.

The second, third, and fourth flights were flown to obtain additional flight data and to trim the RPV for minimum power consumption at cruise. Figure 6-10 presents flight data that is typical for the conditions flown during the fourth flight of the RPV after it had been trimmed. The current draw at the cruise condition is only 32 amps, which is slightly less than anticipated for that condition. The low current draw at cruise will permit a flight time in excess of one hour when the RPV is flown with a lithium thionyl battery.

The rate of climb shown in Figure 6-10 indicates that the vehicle was capable of a climb rate of 950 feet/min. with the electric propulsion system. The exact maximum rate of climb is not known, however, because the instrumentation needle was pegged at 950 feet/min. The actual maximum climb rate is of little concern since the design goal was 300 feet/min.; the motor-controller was easily able to exceed the design goal for rate of climb.

During the flight test of the electric propulsion system ram cooling air was provided to the motor-controller unit through a 2.5 x 2.5 duct. The duct size provided substantially more

cooling air than needed, and the temperature of the unit never exceeded 38 degrees C during flight. When the motor-controller was run at idle for 8 minutes without the benefit of ram air cooling, the unit temperature increased only 14 degrees C above the ambient temperature. The observed low temperatures of the unit when operating at the lower horsepower regimes can be attributed to the high overall efficiency displayed by the motor-controller at these conditions.

### CONCLUSION

The feasibility of using an energy efficient Samarium Cobalt motor-controller as an electrical propulsion system for an RPV was demonstrated with each of the several flights that were flown with the Air Force XBQM-106 RPV. The Sundstrand designed motor-controller was able to meet or exceed all of its design goals throughout the flight test program.

A photograph of the XBQM-106 during an approach for landing is shown in Figure 6-11. This particular flight utilized a silver zinc battery pack, but future demonstration flights are planned with a lithium thionyl chloride battery. The concept of coupling a lithium battery and a high efficiency motor-controller as a propulsion system holds promise for future RPV applications where extended flight times may be desired.

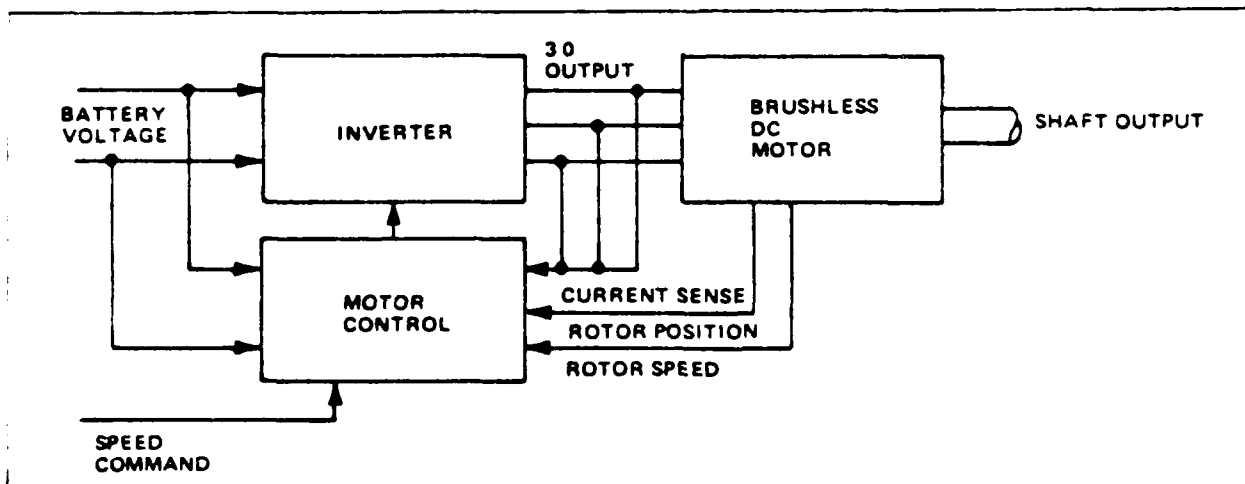

Figure 6-10. Motor and Control

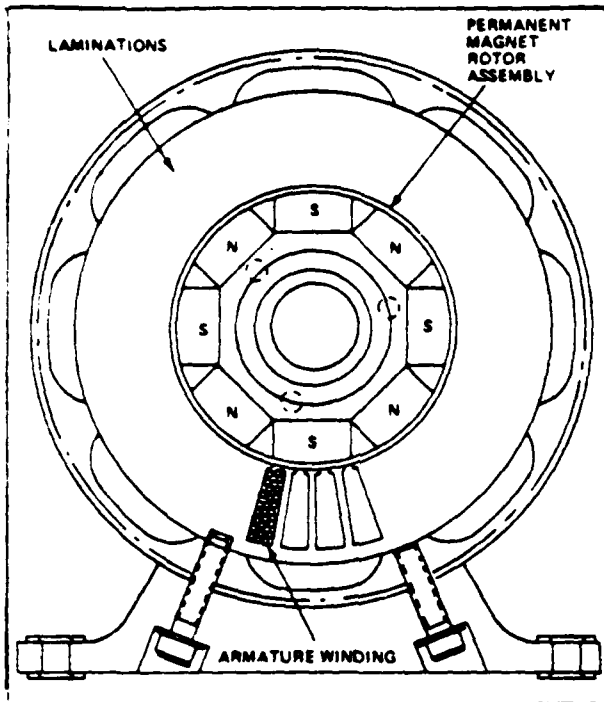

Figure B 2, End View of Motor

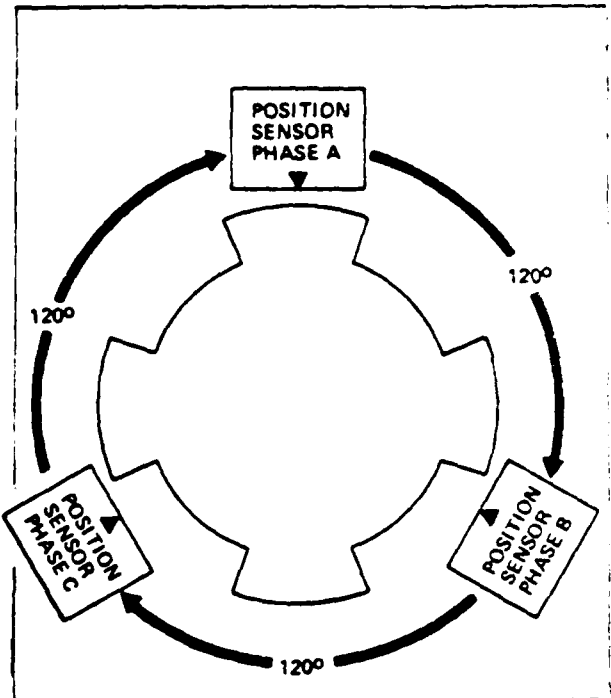

Figure B 3 Rotor Position Sensing

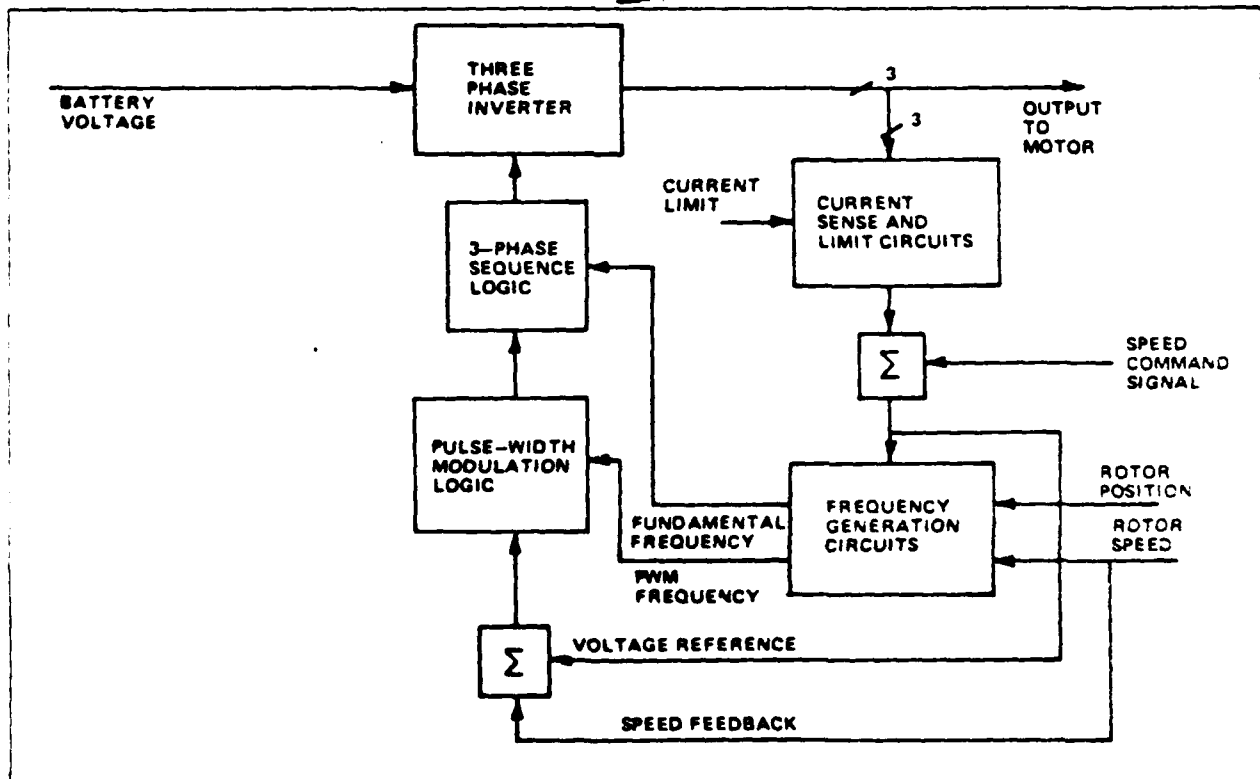

Figure B 4, Controller Block Diagram

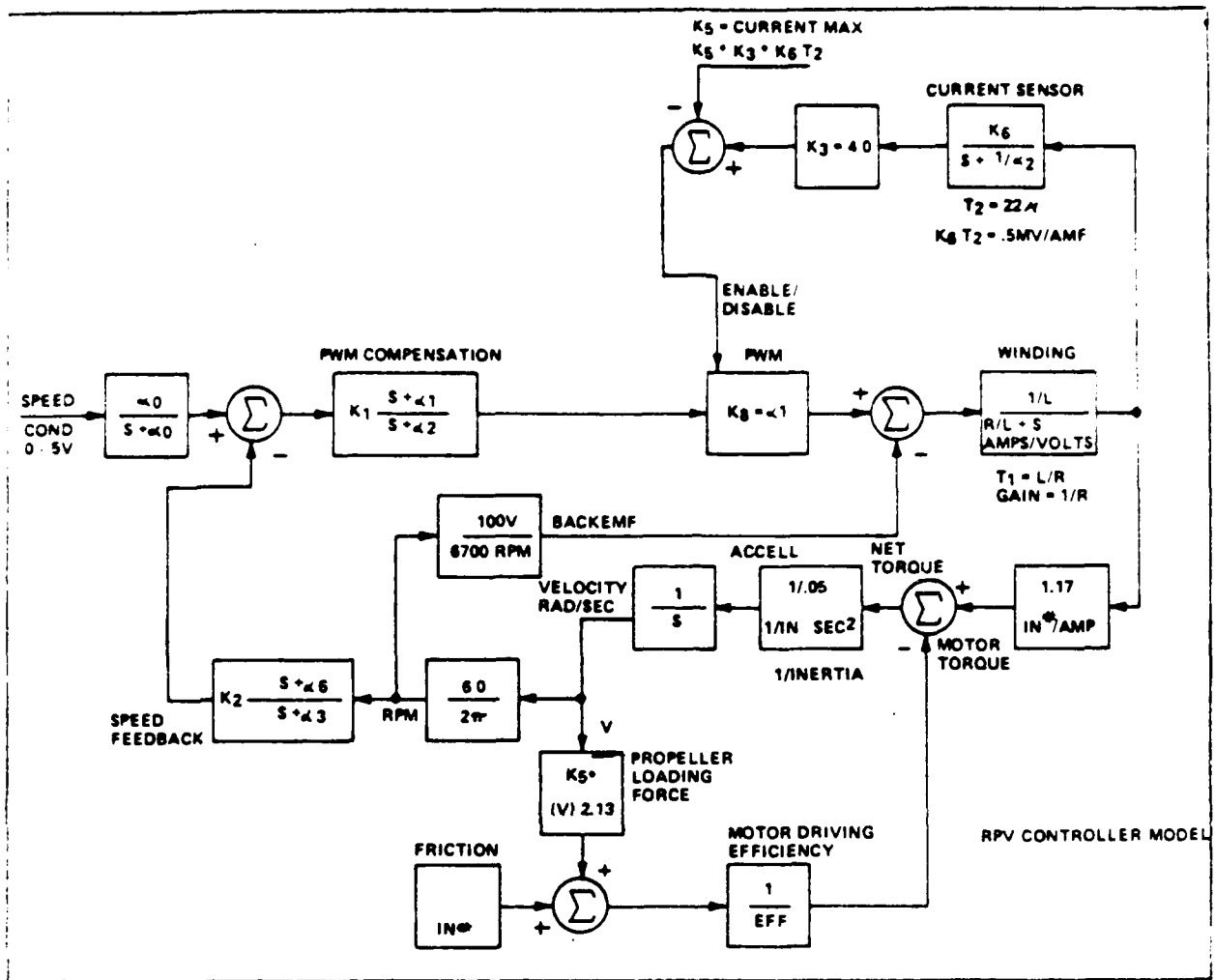

Figure 3.5. Controller Model

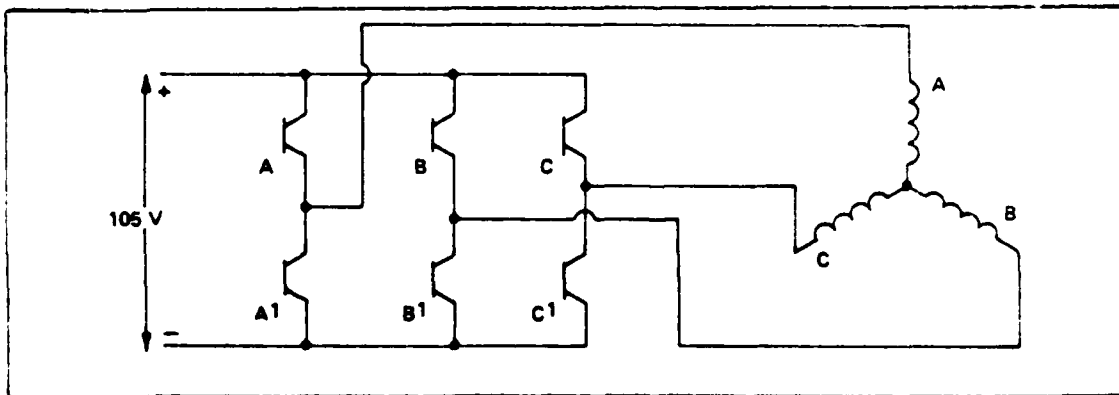

Figure 3.6. Inverter Configuration

PT	VSUP VOLT	SHUNT MVOLT	SPEED RPM	STORQ IN*LB	ISUP AMPS	PWRIN WATTS	POUT HP	POUT WATTS	EFF %
1	126.	1.17	2000.	12.0	3.5	441.	0.38	284.	64.4
2	123.	1.67	2489.	17.5	5.0	615.	0.69	516.	83.8
3	119.	3.33	3000.	26.0	10.0	1190.	1.24	923.	77.6
4	116.	4.67	3400.	34.0	14.0	1624.	1.83	1368.	84.3
5	114.	6.67	3850.	42.0	20.0	2280.	2.57	1914.	83.9
6	111.	9.50	4300.	54.0	28.5	3164.	3.68	2748.	86.9
7	107.	14.33	4900.	68.0	43.0	4601.	5.29	3944.	85.7
8	104.	19.33	5300.	82.0	58.0	6032.	6.90	5144.	85.3
9	106.	28.00	6000.	108.0	84.0	8920.	10.28	7670.	87.0

Figure 3 - RPV Motor / Controller Data Reduction Program

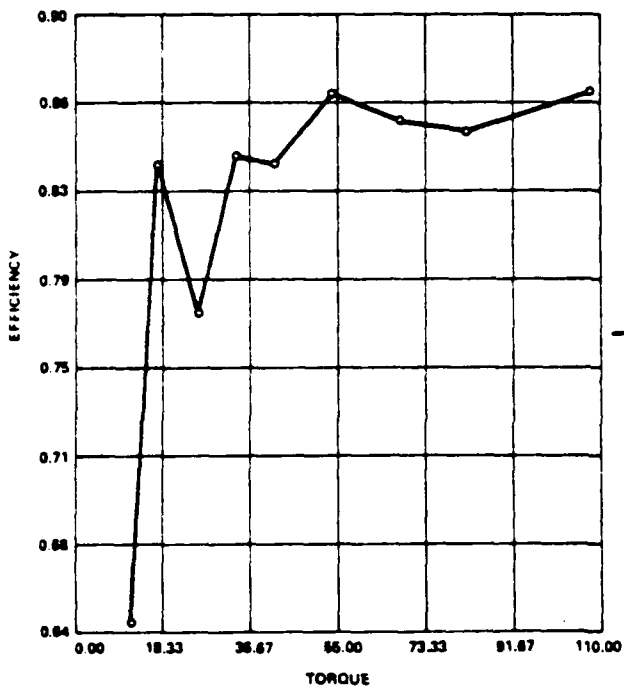

Figure 4 - Sundstrand Motor Test

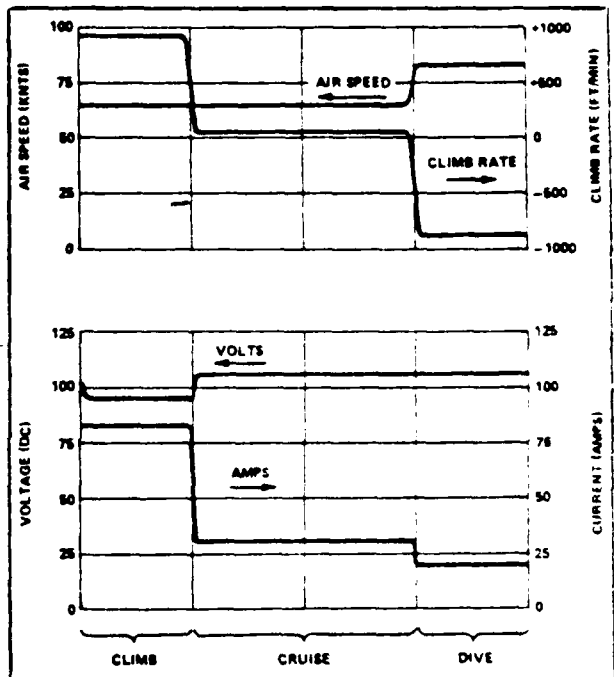

Figure 5 - Performance Parameters

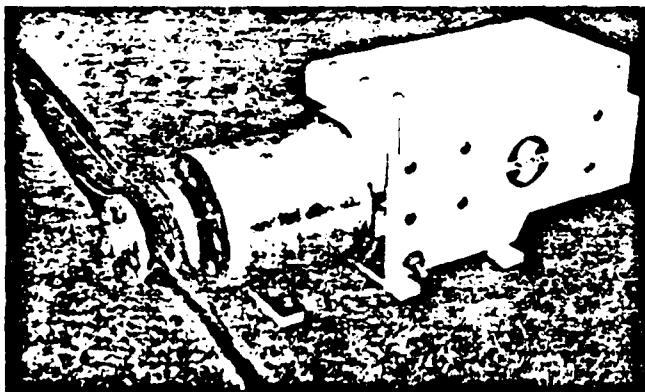

Figure 6 - Flight Package

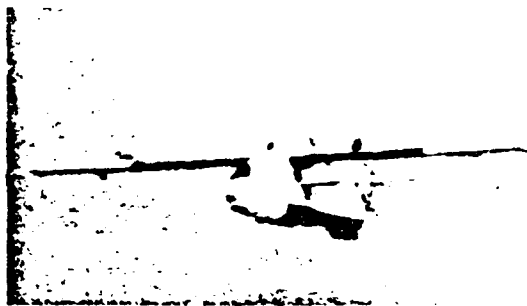

Figure 7 - Flight Operation

APPENDIX C

33-Cell Mini Rpv  
Battery Ground Test No. 2  
Voltage, Current, and Temperature Profiles

AFWAL AERO PROPULSION LABORATORY  
LITHIUM BATTERY TEST

15 OCTOBER 1981

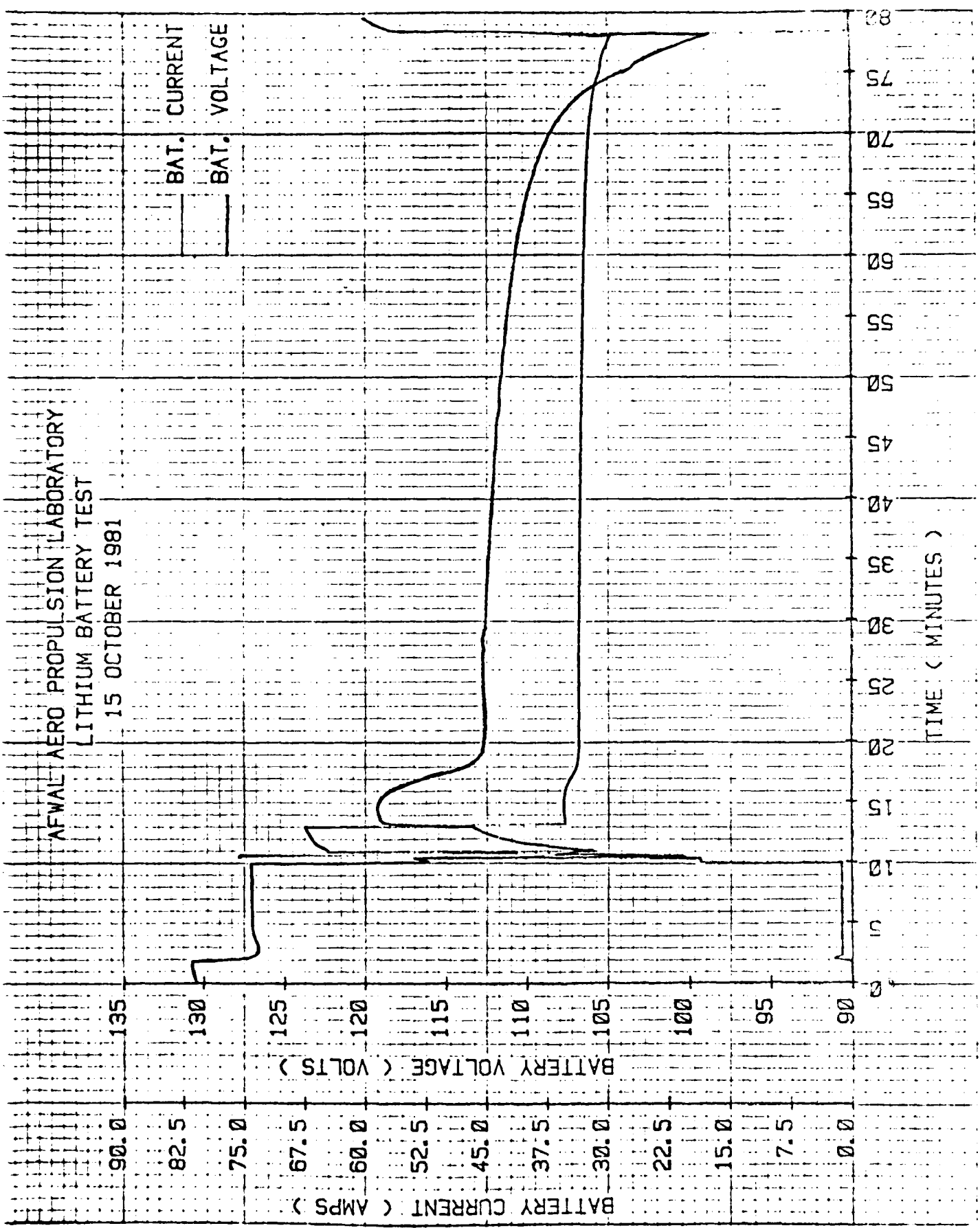

AFWAL AERO PROPULSION LABORATORY  
 LITHIUM BATTERY TEST  
 15 OCTOBER 1981  
 AVG-MAX-MIN

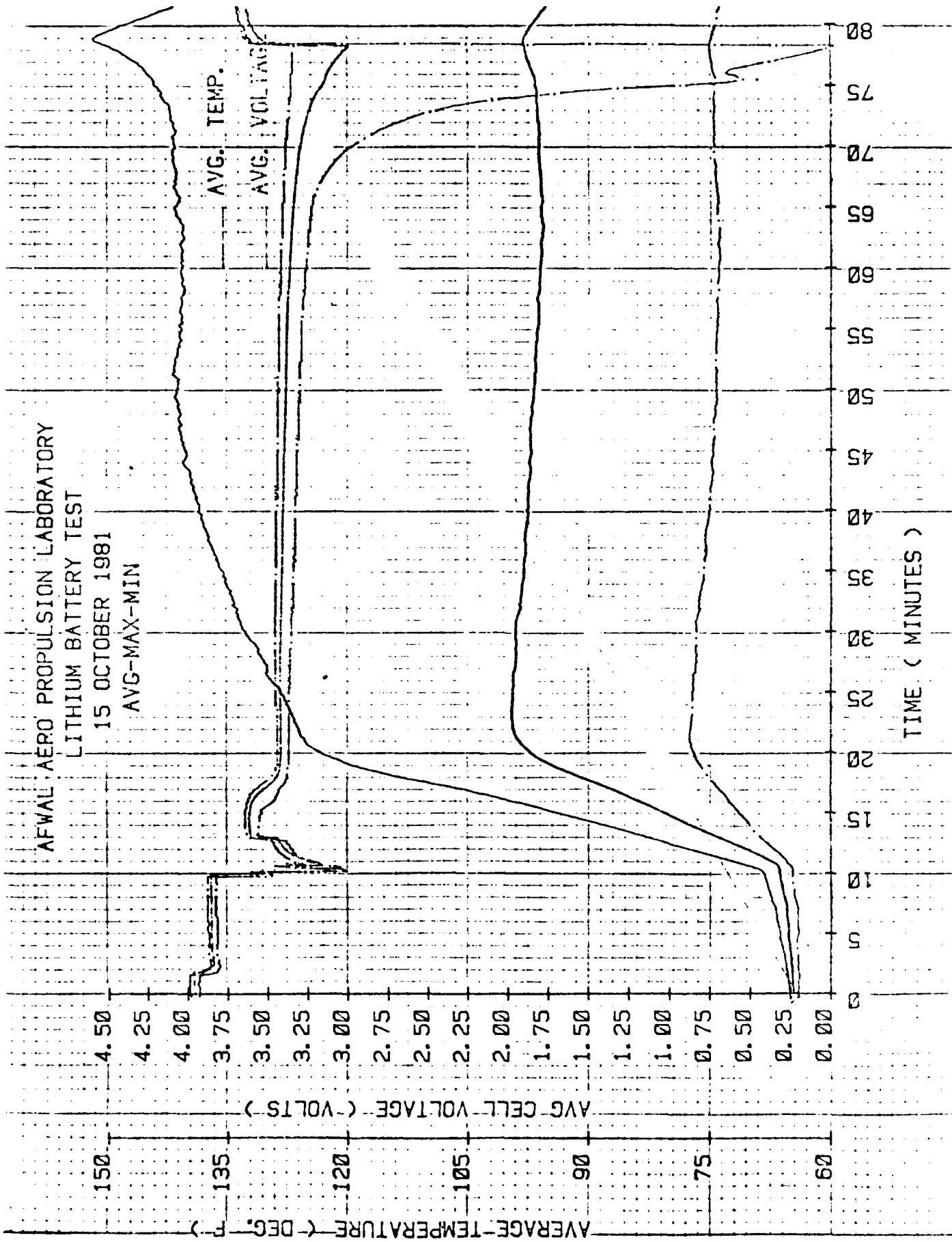

AFWAL AERB PROPULSION LABORATORY  
 LITHIUM BATTERY TEST  
 15 DEC 1981  
 CELL # 1

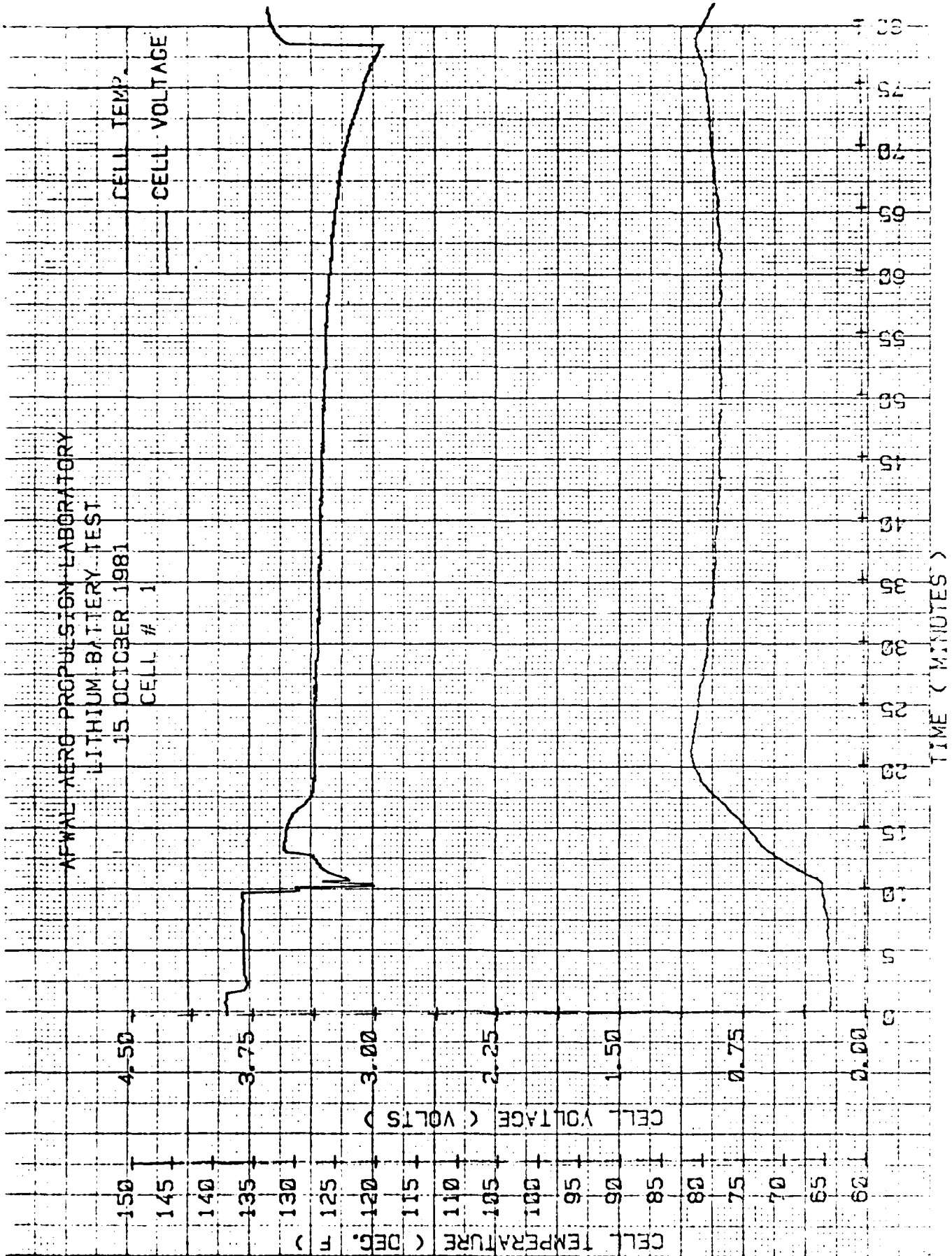

AFWAL AERB PROPULSION LABORATORY  
 LITHIUM BATTERY TEST  
 15 DEC 1981  
 CELL # 1

AERIAL AERO PROPULSION LABORATORY  
LITHIUM BATTERY TEST

15 OCTOBER 1981

CELL # 2

CELL TEMP.

CELL VOLTAGE

150  
4.50

145

140

135  
3.75

130

125

120  
3.00

115

110

105  
2.25

100

95

90  
1.50

85

80

75  
0.75

70

65

60  
0.00

CELL TEMPERATURE ( DEG. F )

CELL VOLTAGE ( VOLTS )

88

85

80

75

70

65

60

55

50

45

40

35

30

25

20

15

10

5

0

TIME ( MINUTES )

AFWAL AERO PROPULSION LABORATORY

LITHIUM BATTERY TEST

15 OCTOBER 1981

CELL # 3

CELL TEMP  
CELL VOLTAGE

150 4.50

145 +

140 +

135 3.75

130 +

125 +

120 3.00

115 +

110 +

125 2.25

100 +

95 +

90 1.50

85 +

80 +

75 0.75

70 +

65 +

60 0.00

CELL TEMPERATURE ( DEG F )

CELL VOLTAGE ( VOLTS )

TIME ( MINUTES )

35

30

25

20

15

10

5

0

35

30

25

20

15

10

5

0

35

30

25

20

15

10

5

0

AFWAL-AERO PROPULSION LABORATORY  
LITHIUM BATTERY TEST

15 OCTOBER 1981  
CELL # 4

CELL TEMP.  
CELL VOLTAGE

150  
145  
140  
135  
130  
125  
120  
115  
110  
105  
100  
95  
90  
85  
80  
75  
70  
65  
60

CELL TEMPERATURE ( DEG. F )  
CELL VOLTAGE ( VOLTS )

4.50  
3.75  
3.00  
2.25  
1.50  
0.75  
0.00

0 5 10 15 20 25 30 35 40 45 50 55 60 65 70 75 80

TIME ( MINUTES )

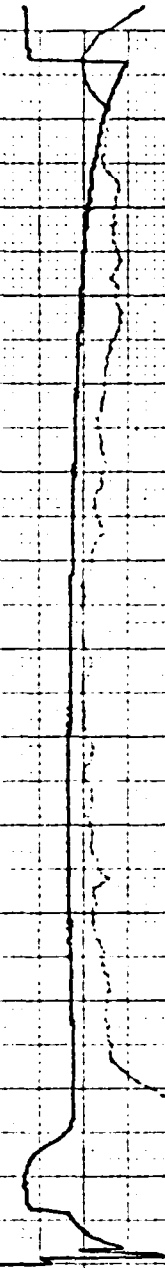

AEWAL AERO PROPULSION LABORATORY  
 LITHIUM BATTERY TEST  
 15 OCTOBER 1981  
 CELL # 5

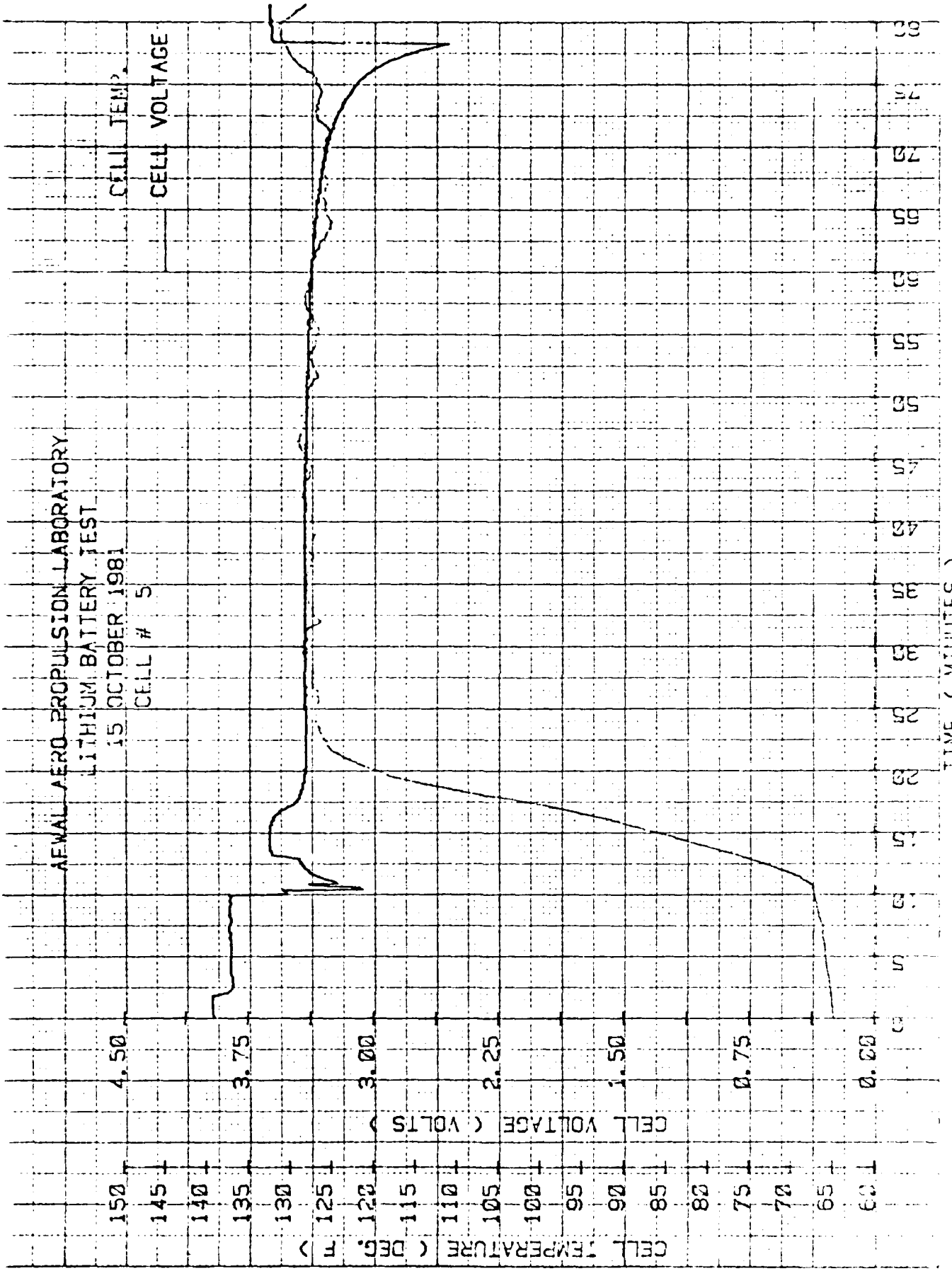

TIME ( MINUTES )  
 0 5 10 15 20 25 30 35 40 45 50 55 60 65 70 75 80 85 90 95 100

CELL TEMPERATURE ( DEG. F )  
 150  
145  
140  
135  
130  
125  
120  
115  
110  
105  
100  
95  
90  
85  
80  
75  
70  
65  
60

CELL VOLTAGE ( VOLTS )  
 4.50  
3.75  
3.00  
2.25  
1.50  
0.75  
0.00

AEWAL AERO PROPULSION LABORATORY  
LITHIUM BATTERY TEST

15 OCTOBER 1981  
CELL # 6

CELL TEMP.  
CELL VOLTAGE

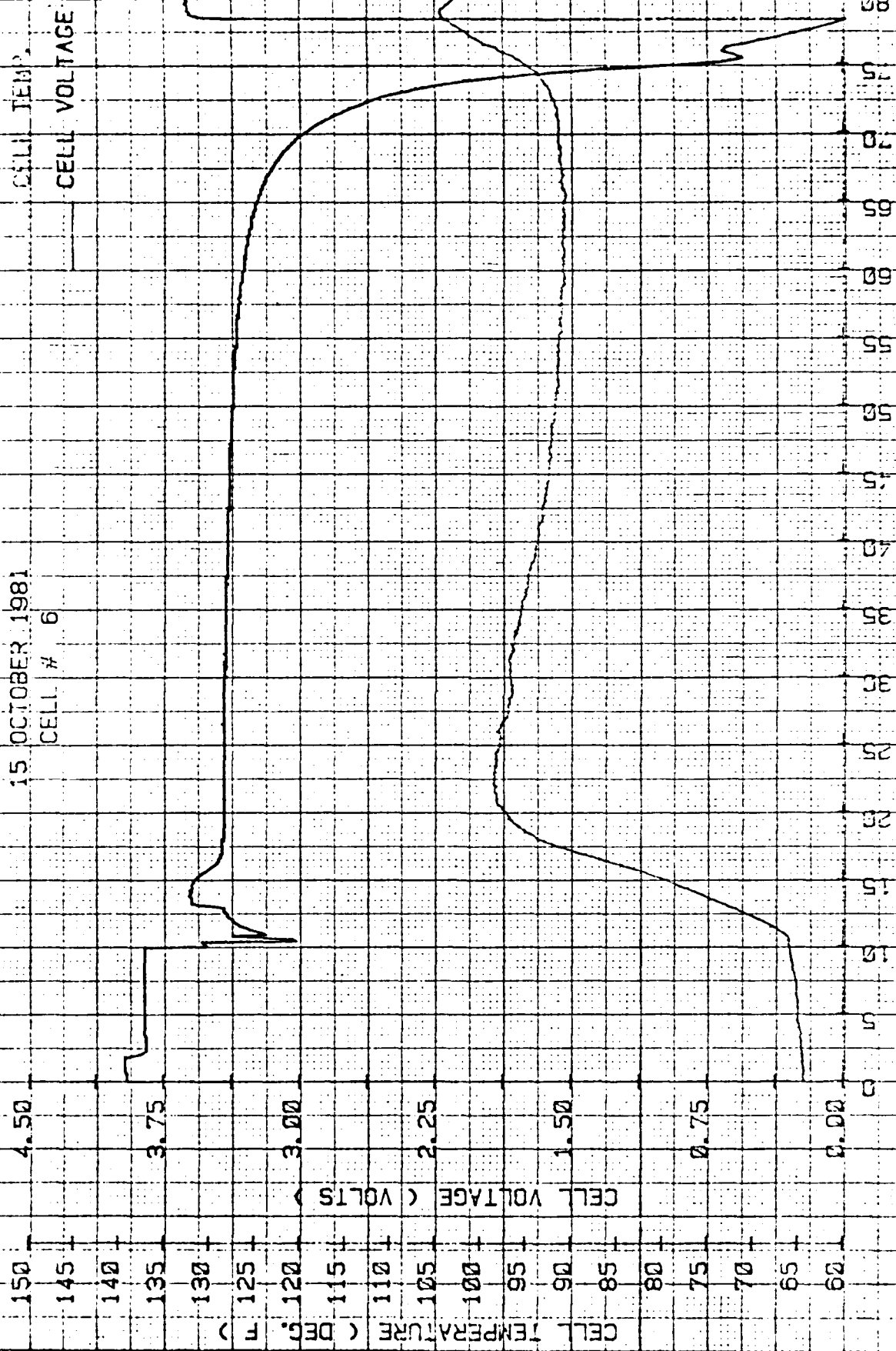

TIME ( MINUTES )

AFWAL AERO PROPULSION LABORATORY  
LITHIUM BATTERY TEST

15 OCTOBER 1981  
CELL # 7

CELL TEMP  
CELL VOLTAGE

150  
4.50

145  
3.75

140  
3.00

135  
2.25

130  
1.50

125  
0.75

120  
0.00

115

110

105

100

95

90

85

80

75

70

65

60

CELL TEMPERATURE ( DEG. F )

CELL VOLTAGE ( VOLTS )

TIME ( MINUTES )

0 5 10 15 20 25 30 35 40 45 50 55 60 65 70 75 80 85 90

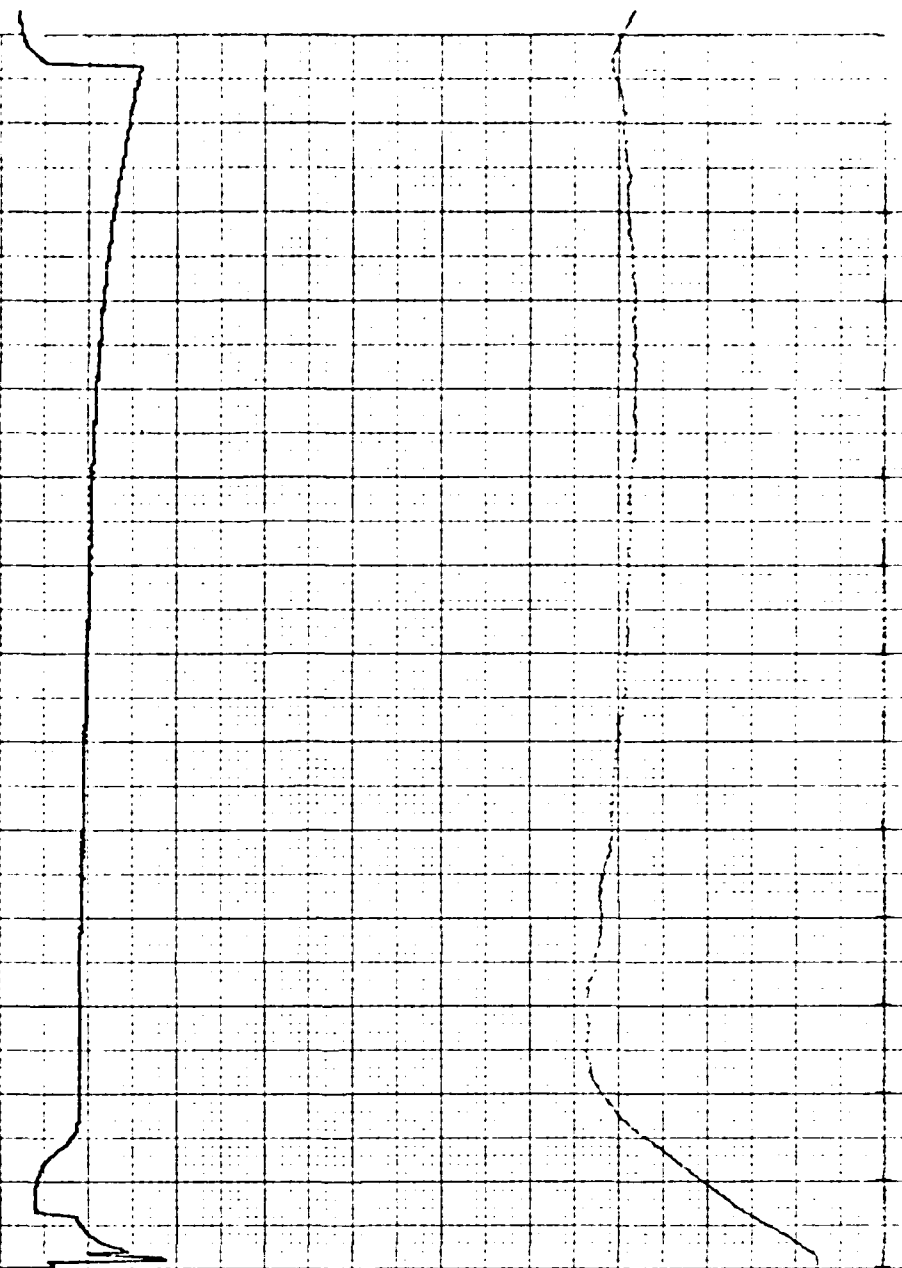

AFWAL AERO PROPULSION LABORATORY  
LITHIUM BATTERY TEST

15 OCTOBER 1981

CELL # 8

CELL TEMP.

CELL VOLTAGE

4.50

3.75

3.00

2.25

1.50

0.75

0.00

150

145

140

135

130

125

120

115

110

105

100

95

90

85

80

75

70

65

60

CELL TEMPERATURE ( DEG. F )

CELL VOLTAGE ( VOLTS )

80

75

70

65

60

55

50

45

40

35

30

25

20

15

10

5

0

TIME ( MINUTES )

AFMAL AERO PROPULSION LABORATORY  
 LITHIUM BATTERY TEST  
 15 OCTOBER 1981  
 CELL # 9



AFMAL AERO PROPULSION LABORATORY  
LITHIUM BATTERY TEST

15 OCTOBER 1981

CELL # 10

CELL TEMP.  
CELL VOLTAGE

4.50

150

145

140

135

130

125

120

115

110

105

100

95

90

85

80

75

70

65

60

CELL VOLTAGE ( VOLTS )

3.00

2.25

1.50

0.75

0.00

CELL TEMPERATURE ( DEG F )

80  
75  
70  
65  
60  
55  
50  
45  
40  
35  
30  
25  
20  
15  
10  
5  
0

TIME ( MINUTES )

AFMAL AERO PROPULSION LABORATORY  
LITHIUM BATTERY TEST  
15 OCTOBER 1981  
CELL # 10

AFWAL AERO PROPULSION LABORATORY  
LITHIUM BATTERY TEST

15 OCTOBER 1981  
CELL # 11

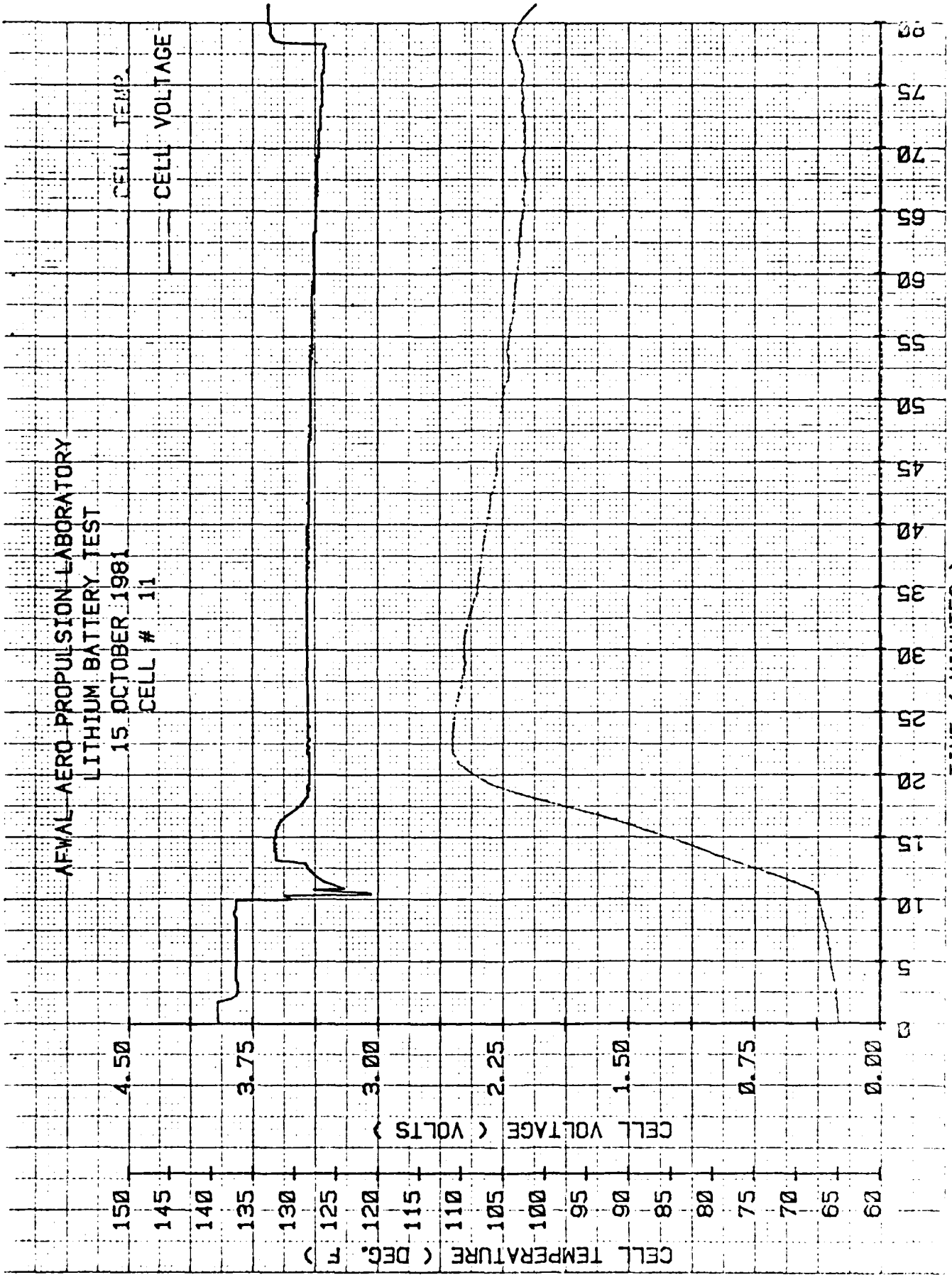

TIME ( MINUTES )

AFWAL AERO PROPULSION LABORATORY  
 LITHIUM BATTERY TEST  
 15 OCTOBER 1981  
 CELL # 12

CELL TEMP.

CELL VOLTAGE

4.50

3.75

3.00

2.25

1.50

0.75

0.00

150

145

140

135

130

125

120

115

110

105

100

95

90

85

80

75

70

65

60

CELL TEMPERATURE ( DEG. F )

CELL VOLTAGE ( VOLTS )

0 5 10 15 20 25 30 35 40 45 50 55 60 65 70 75 80

TIME ( MINUTES )

AFWAL AERO-PROPULSION LABORATORY  
 LITHIUM BATTERY TEST  
 15 OCTOBER 1981  
 CELL # 13

CELL TEMP. A  
 CELL VOLTAGE

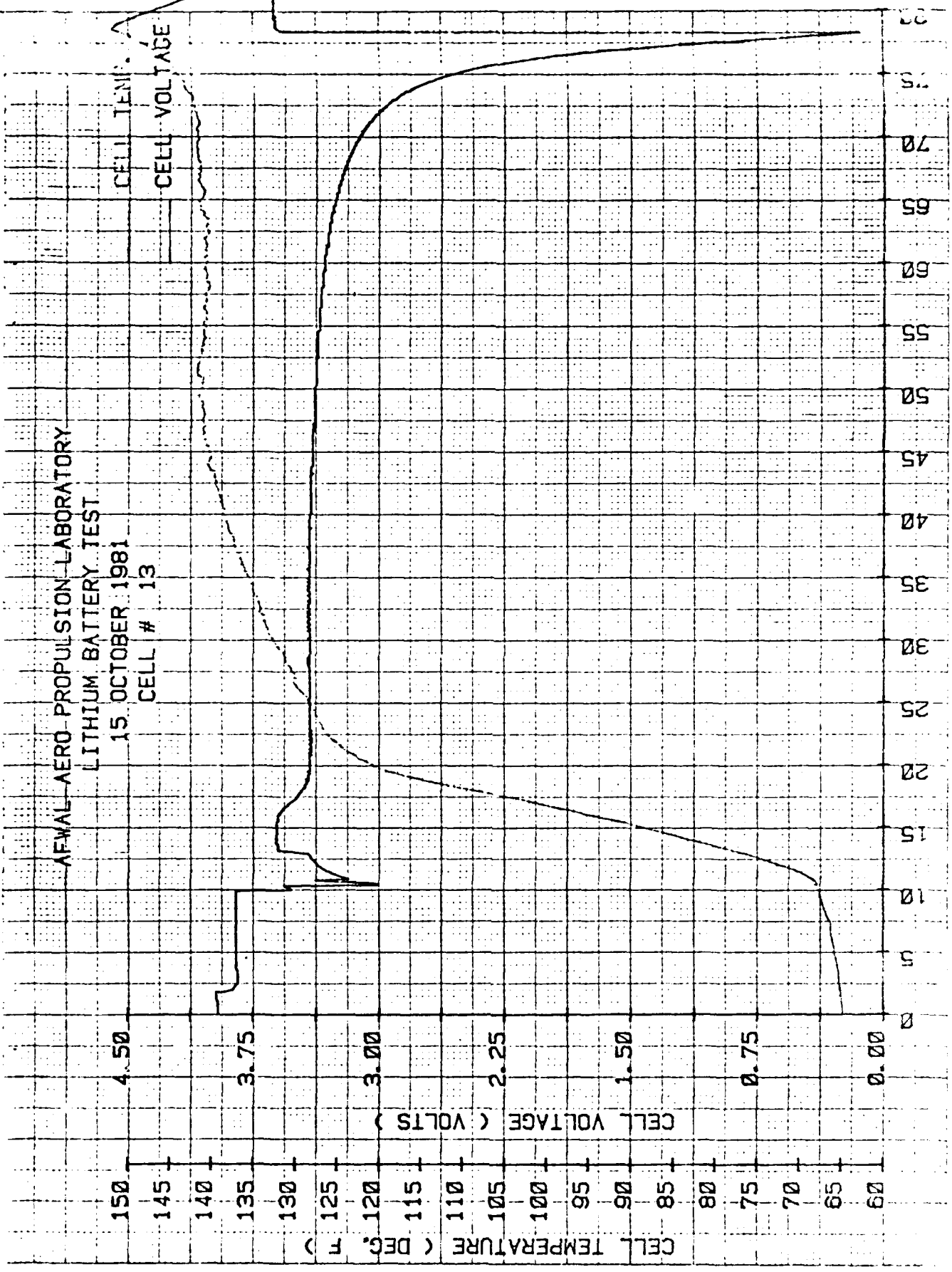

TIME ( MINUTES )

AFWAL AERO-PROPULSION LABORATORY  
LITHIUM BATTERY TEST

15 OCTOBER 1981  
CELL # 14

150 4.50

145

140

135 3.75

130

125

120 3.00

115

110

105 2.25

100

95

90 1.50

85

80

75 0.75

70

65

60 0.00

CELL TEMPERATURE ( DEG. F )

CELL VOLTAGE ( VOLTS )

CELL TEMP.  
CELL VOLTAGE

80  
75  
70  
65  
60  
55  
50  
45  
40  
35  
30  
25  
20  
15  
10  
5  
0

TIME ( MINUTES )

AFWAL AERO PROPULSION LABORATORY  
 LITHIUM BATTERY TEST  
 15 OCTOBER 1981  
 CELL # 15

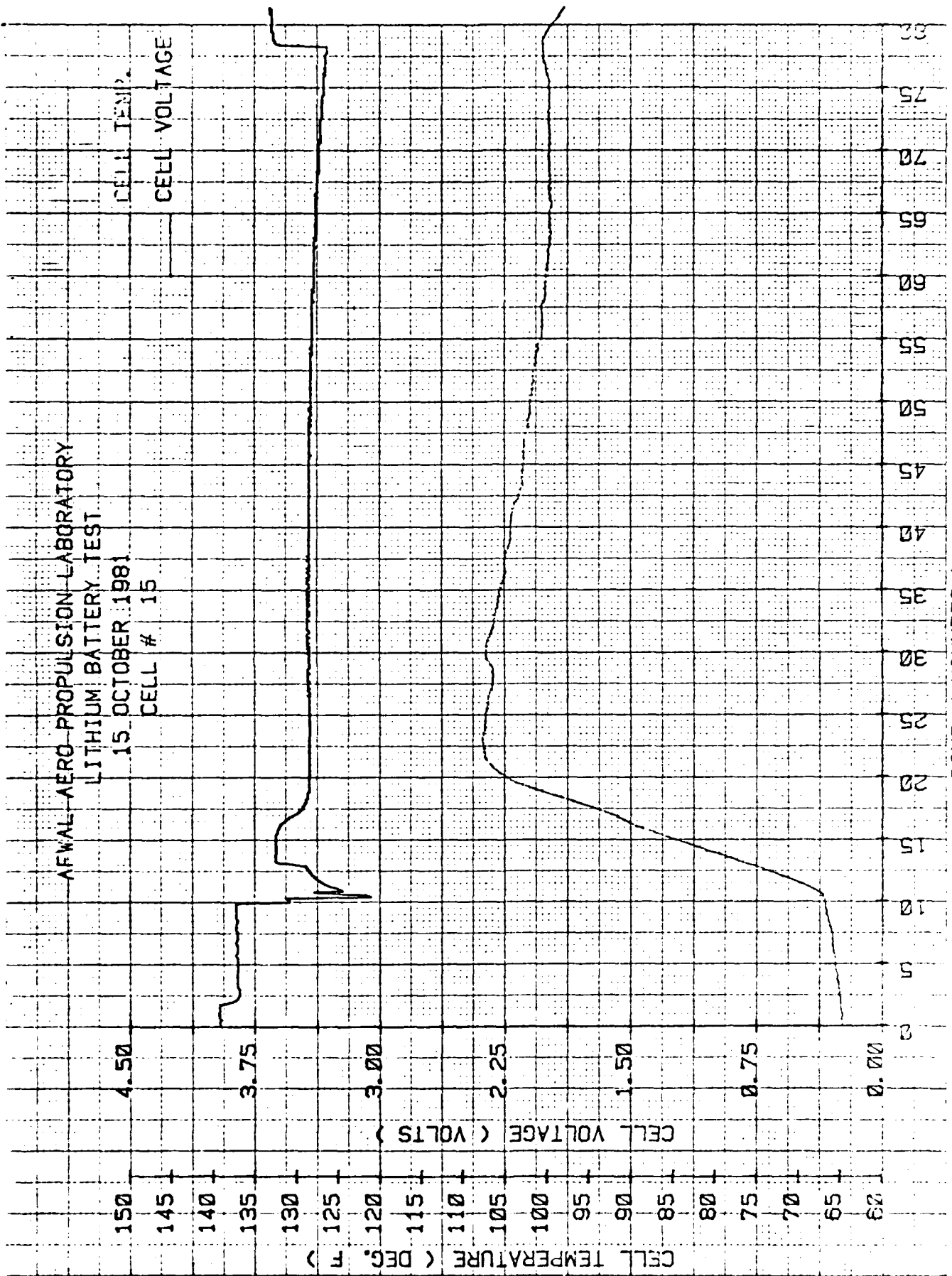

TIME ( MINUTES )

AFVAL AERO PROPULSION LABORATORY  
LITHIUM BATTERY TEST

15 OCTOBER 1981  
CELL # 16

CELL TEMP.  
CELL VOLTAGE

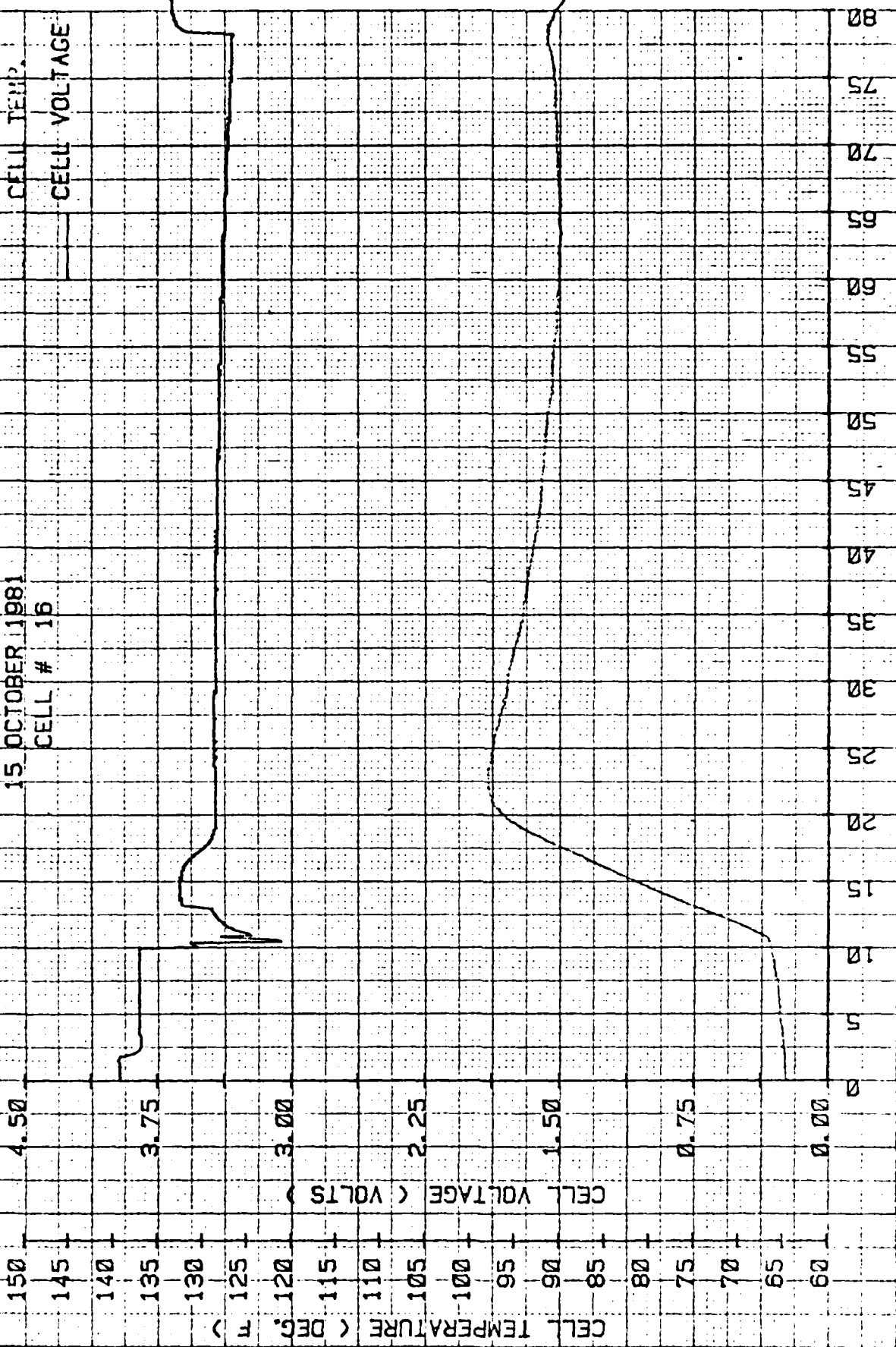

TIME ( MINUTES )

AFWAL AERO PROPULSION LABORATORY  
LITHIUM BATTERY TEST

15 OCTOBER 1981

CELL # 17

150 4.50

145

140

135 3.75

130

125

120 3.00

115

110

105 2.25

100

95

90 1.50

85

80

75 0.75

70

65

60 0.00

CELL TEMP.

CELL VOLTAGE

TIME ( MINUTES )

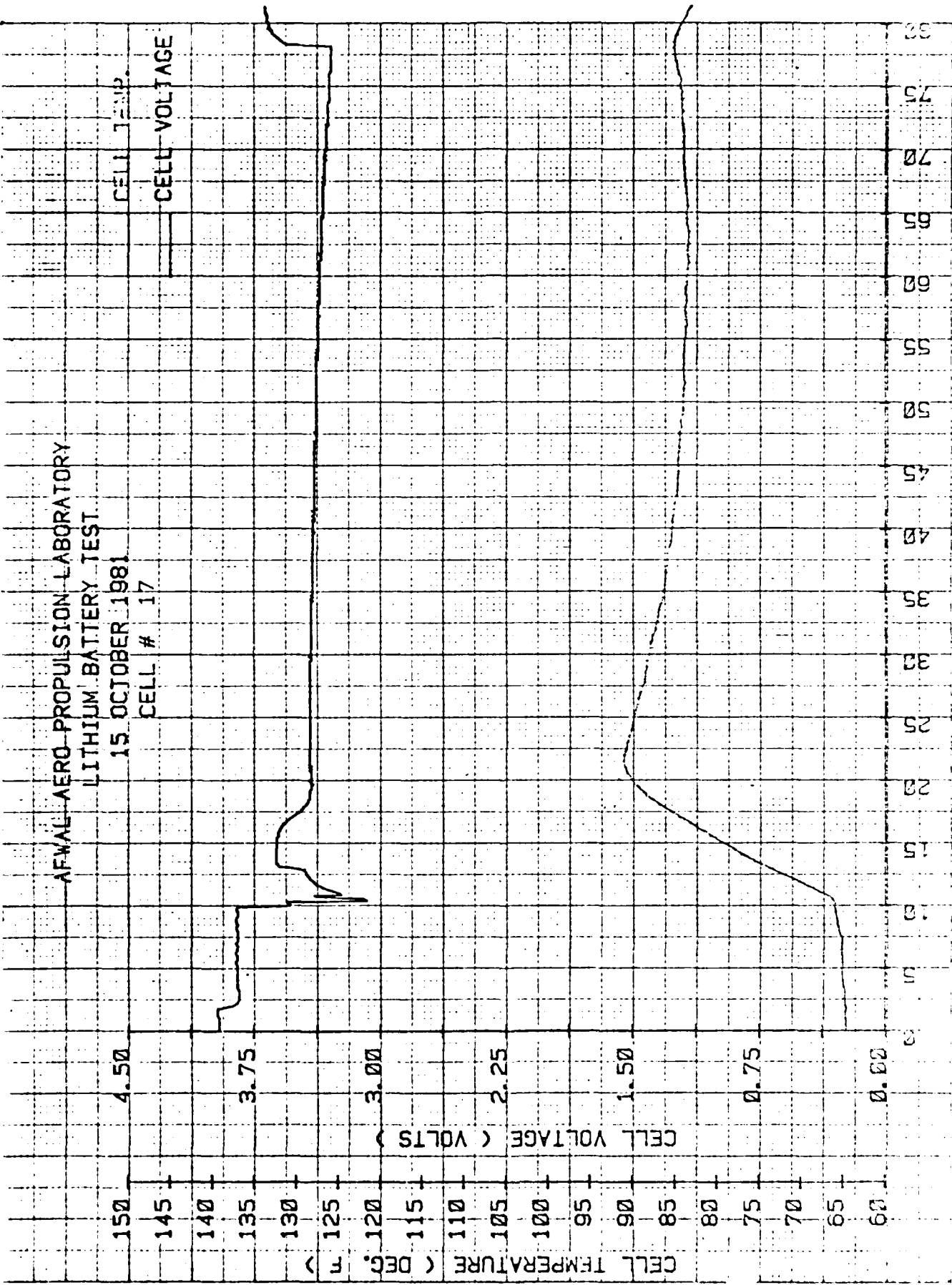

AFWAL AERO PROPULSION LABORATORY  
LITHIUM BATTERY TEST

15 OCTOBER 1981  
CELL # 18

CELL TEMP.  
CELL VOLTAGE

4.50

3.75

3.00

2.25

1.50

0.75

0.00

150

145

140

135

130

125

120

115

110

105

100

95

90

85

80

75

70

65

60

CELL VOLTAGE ( VOLTS )

CELL TEMPERATURE ( DEG. F )

80  
75  
70  
65  
60  
55  
50  
45  
40  
35  
30  
25  
20  
15  
10  
5  
0

TIME ( MINUTES )

AFWAL AERO-PROPULSION LABORATORY  
 LITHIUM BATTERY TEST  
 15 OCTOBER 1981  
 CELL # 19

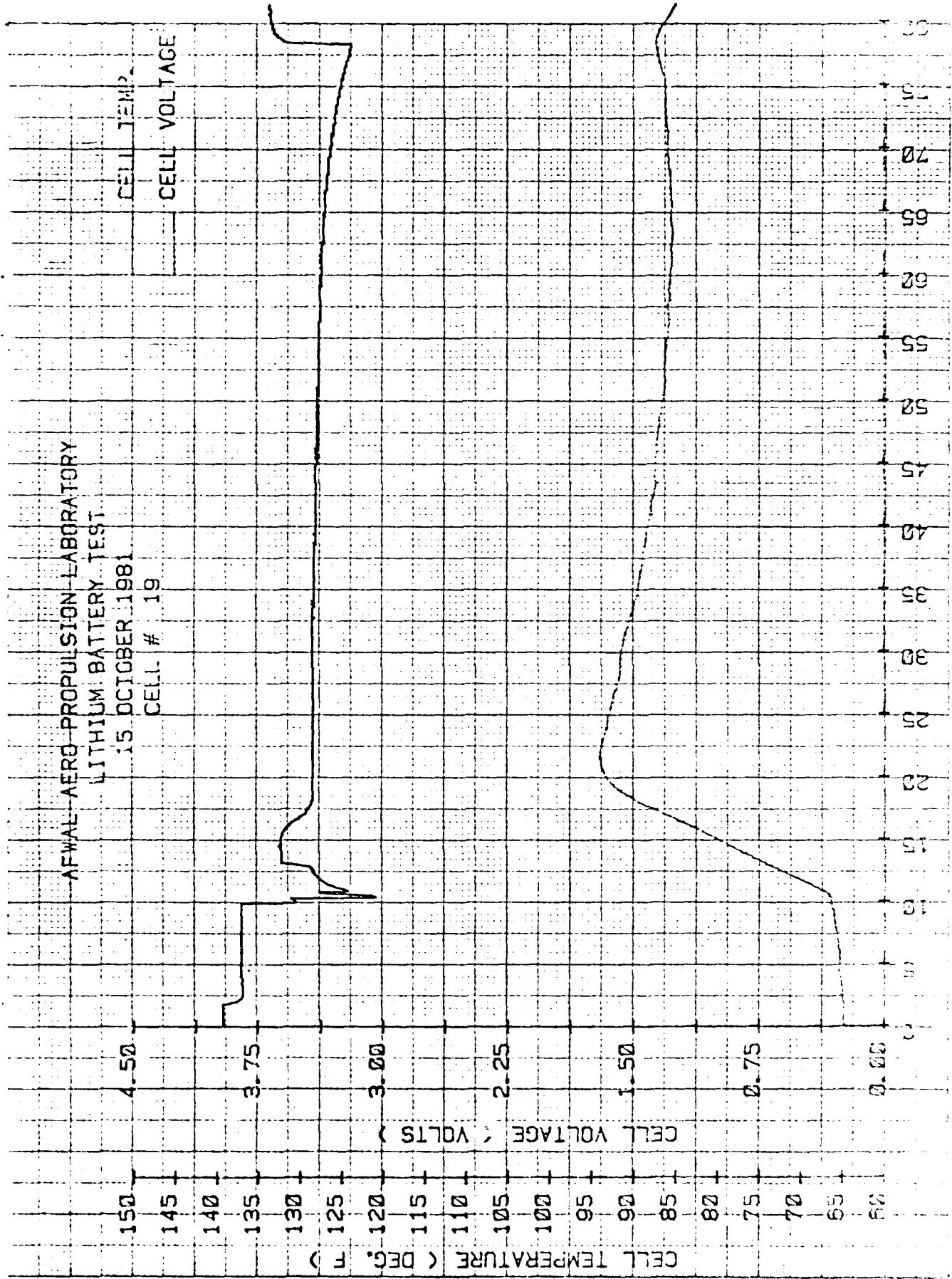

AFWAL AERO PROPULSION LABORATORY  
LITHIUM BATTERY TEST

15 OCTOBER 1981  
CELL # 20

CELL TEMP.  
CELL VOLTAGE

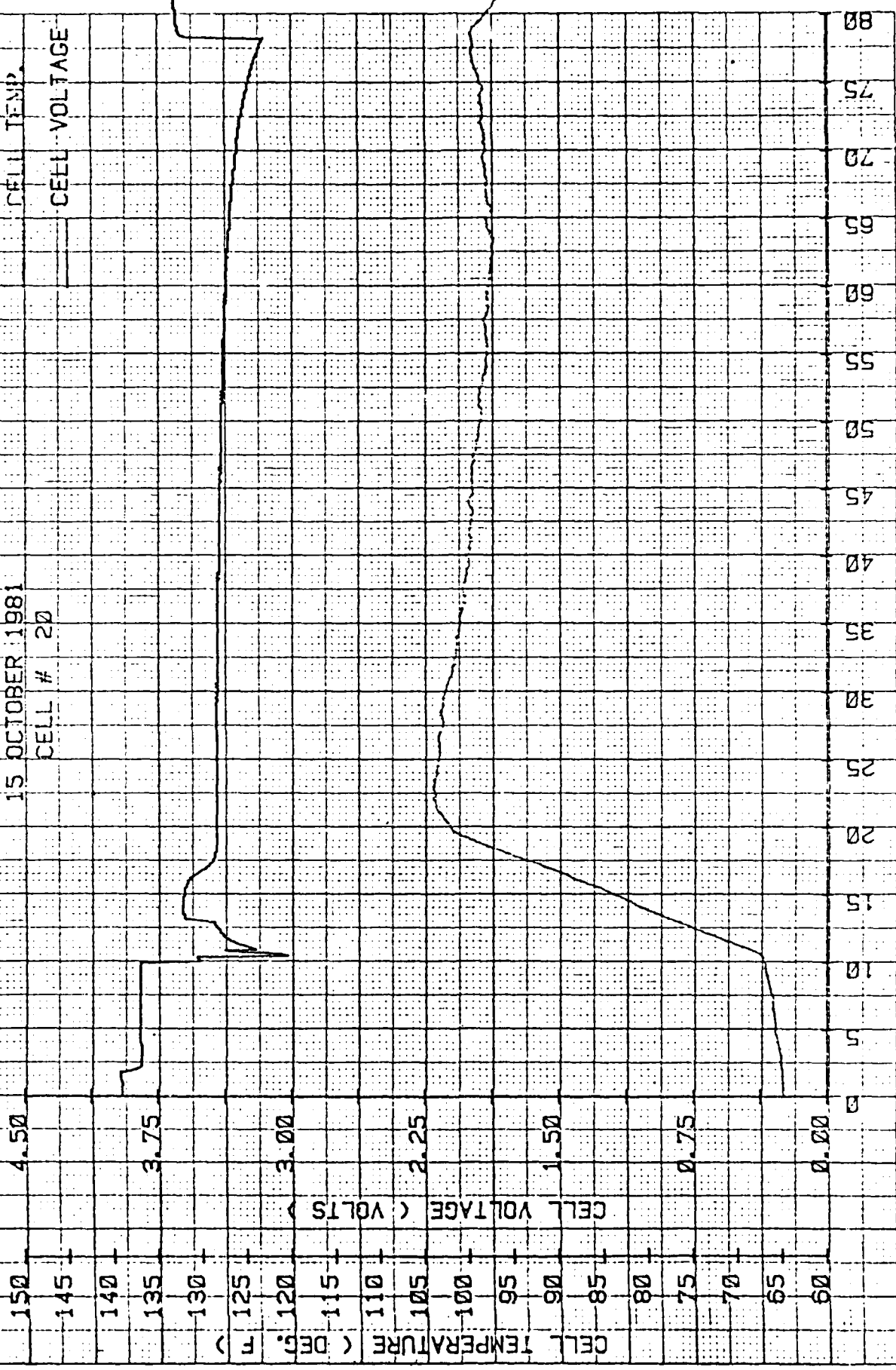

TIME ( MINUTES )

AFWAL AERO PROPULSION LABORATORY LITHIUM BATTERY TEST 15 OCTOBER 1981 CELL # 20

AFWAL AERO PROPULSION LABORATORY

LITHIUM BATTERY TEST

15 OCTOBER 1981

CELL # 21

CELL TEMP.

CELL VOLTAGE

150

145

140

135

130

125

120

115

110

105

100

95

90

85

80

75

70

65

60

4.50

3.75

3.00

2.25

1.50

0.75

0.00

CELL VOLTAGE ( VOLTS )

CELL TEMPERATURE ( DEG. F )

75  
72  
69  
66  
63  
60  
57  
54  
51  
48  
45  
42  
39  
36  
33  
30  
27  
24  
21  
18  
15  
12  
9  
6  
3  
0

TIME ( MINUTES )

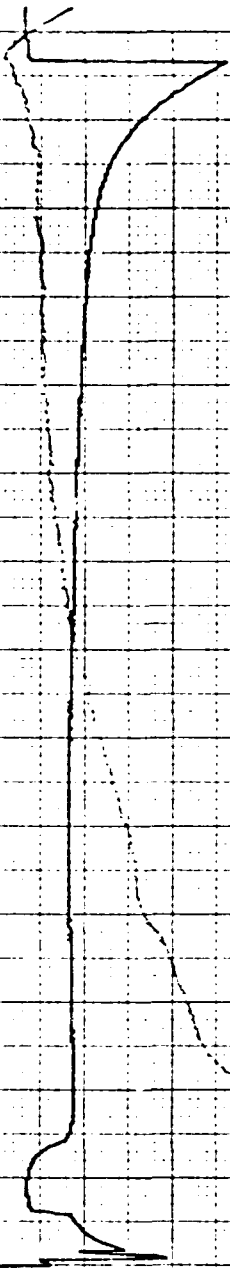

AFWAL AERO PROPULSION LABORATORY  
LITHIUM BATTERY TEST

15 OCTOBER 1981  
CELL # 22

CELL TEMP.  
CELL VOLTAGE

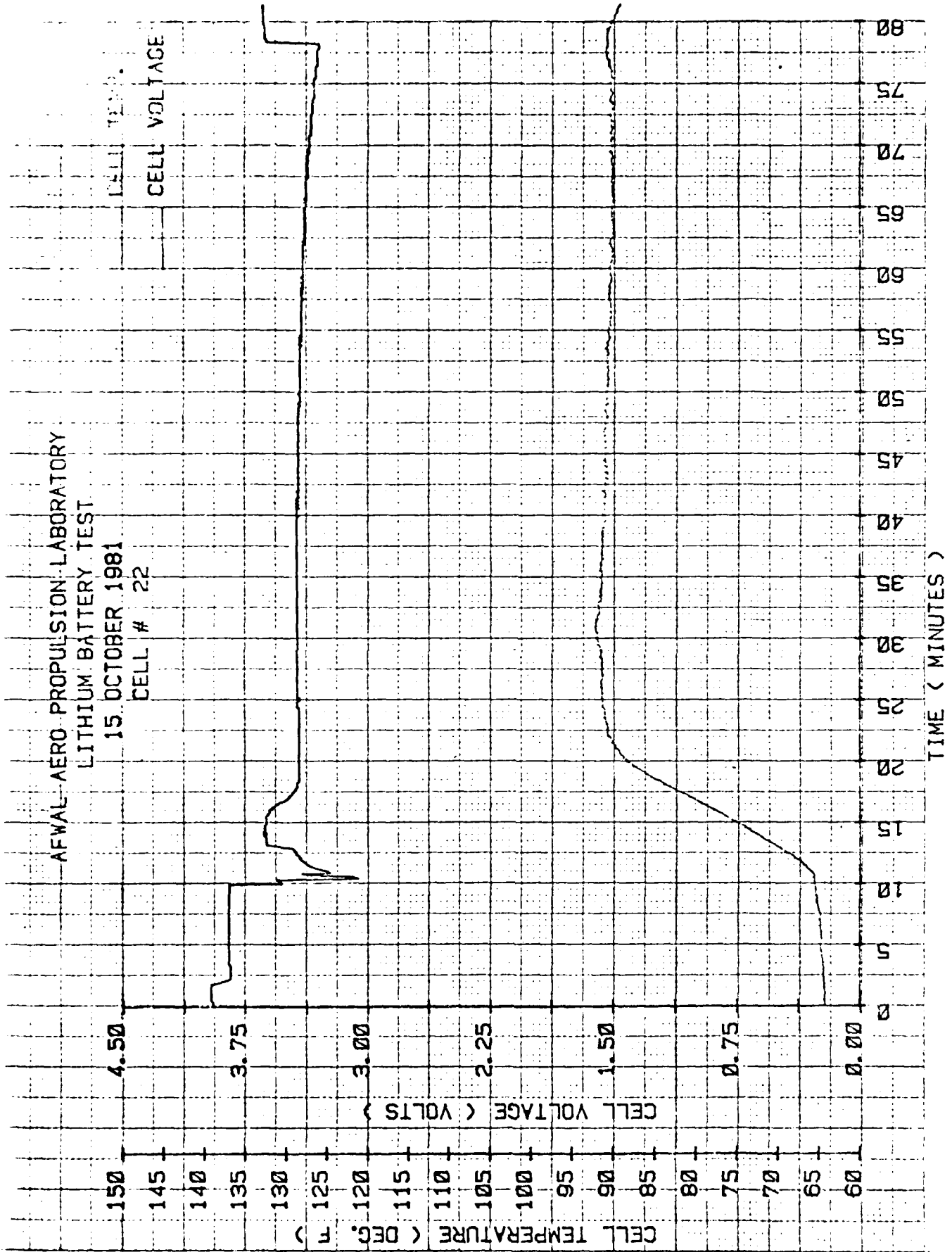

AFVAL AERO PROPULSION LABORATORY  
 LITHIUM BATTERY TEST  
 15 OCTOBER 1981  
 CELL # 23

CELL TEMP  
 CELL VOLTAGE

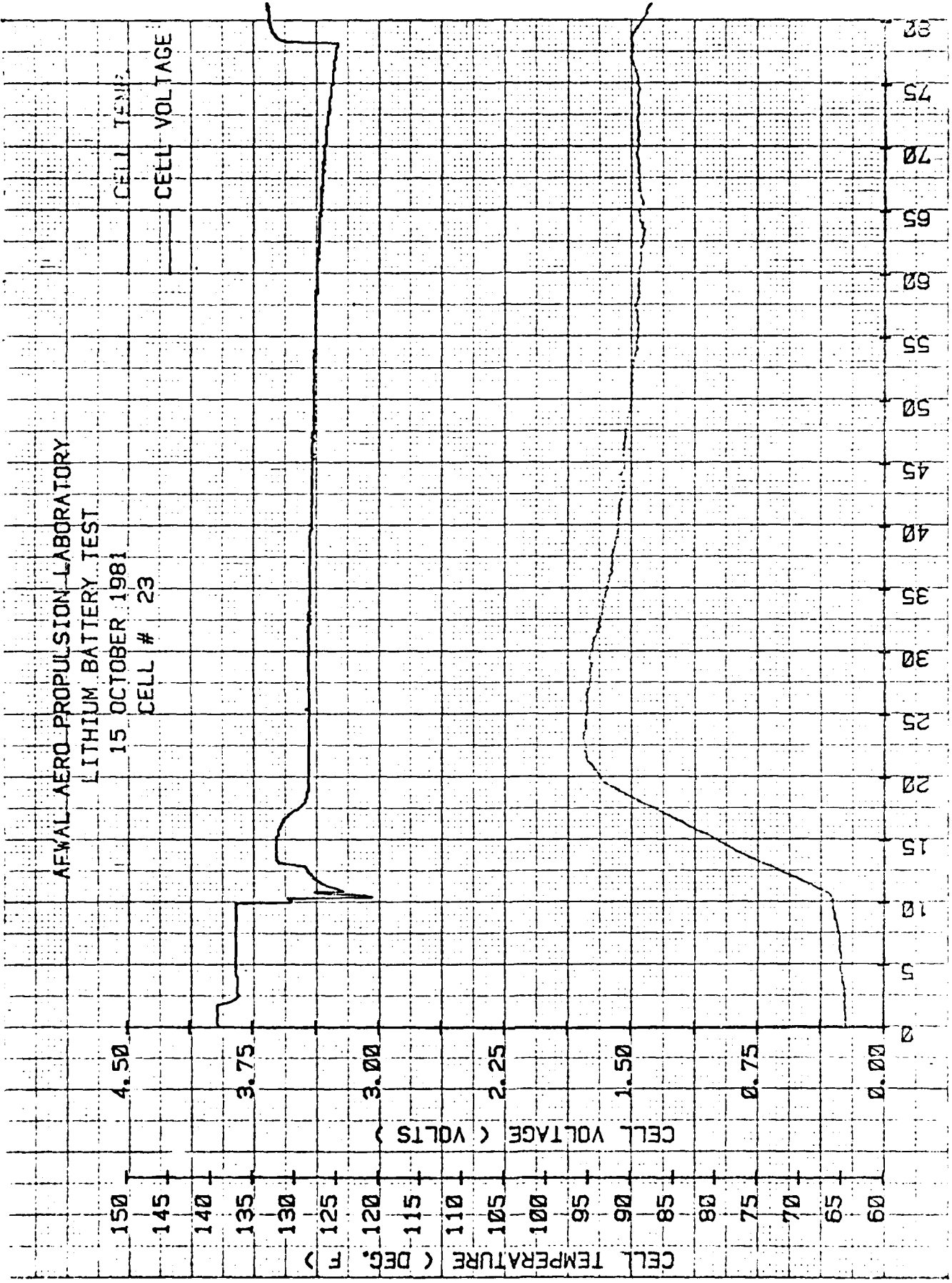

TIME ( MINUTES )

AEWAL AERO PROPULSION LABORATORY  
LITHIUM BATTERY TEST

15 OCTOBER 1981  
CELL # 24

CELL TEMP.  
CELL VOLTAGE

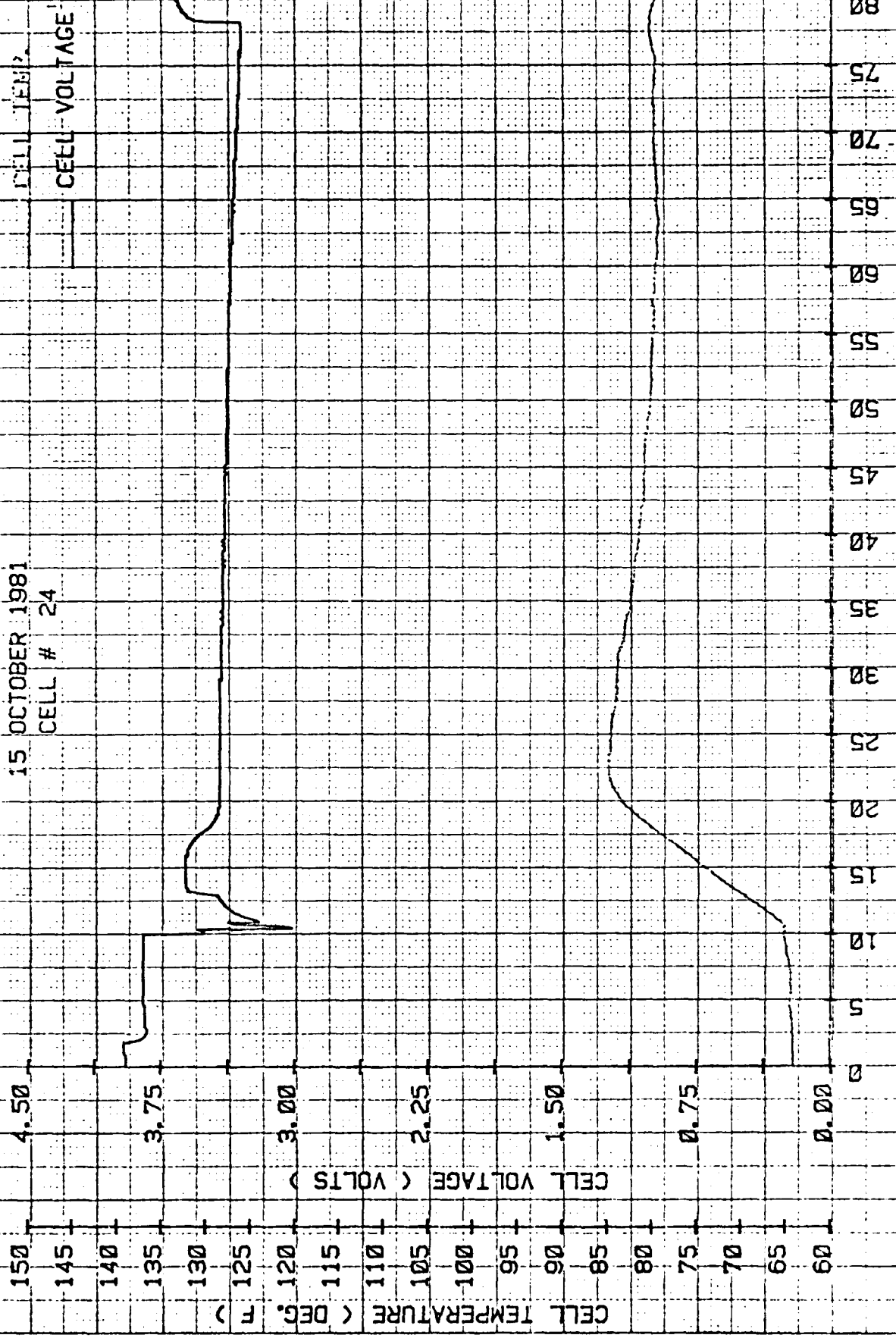

TIME ( MINUTES )

AFWAL AERO-PROPULSION LABORATORY  
 LITHIUM BATTERY TEST  
 15 OCTOBER 1981  
 CELL # 25

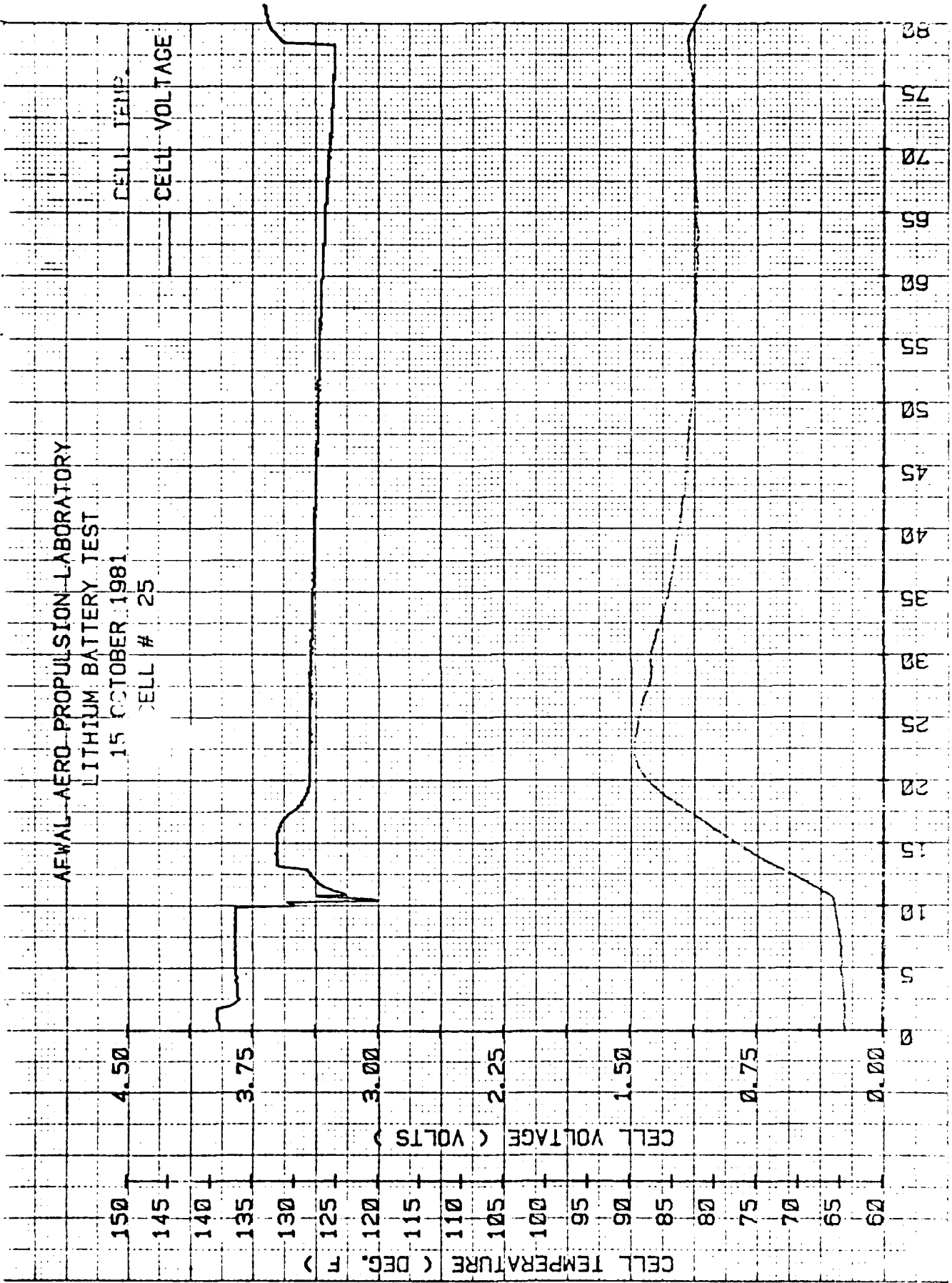

TIME ( MINUTES )

CELL TEMP.  
 CELL VOLTAGE

150  
145  
140  
135  
130  
125  
120  
115  
110  
105  
100  
95  
90  
85  
80  
75  
70  
65  
60

4.50  
3.75  
3.00  
2.25  
1.50  
0.75  
0.00

CELL TEMPERATURE ( DEG. F )  
 CELL VOLTAGE ( VOLTS )

AFMAL AERO PROPULSION LABORATORY  
LITHIUM BATTERY TEST

15 OCTOBER 1981  
CELL # 26

CELL TEMP  
CELL VOLTAGE

4.50

3.75

3.00

2.25

1.50

0.75

0.00

150

145

140

135

130

125

120

115

110

105

100

95

90

85

80

75

70

65

60

CELL VOLTAGE ( VOLTS )

CELL TEMPERATURE ( DEG. F )

80  
75  
70  
65  
60  
55  
50  
45  
40  
35  
30  
25  
20  
15  
10  
5  
0

TIME ( MINUTES )

AFWAL AERO PROPULSION LABORATORY  
 LITHIUM BATTERY TEST  
 15 OCTOBER 1981  
 CELL # 27

CELL TEMP.  
 CELL VOLTAGE

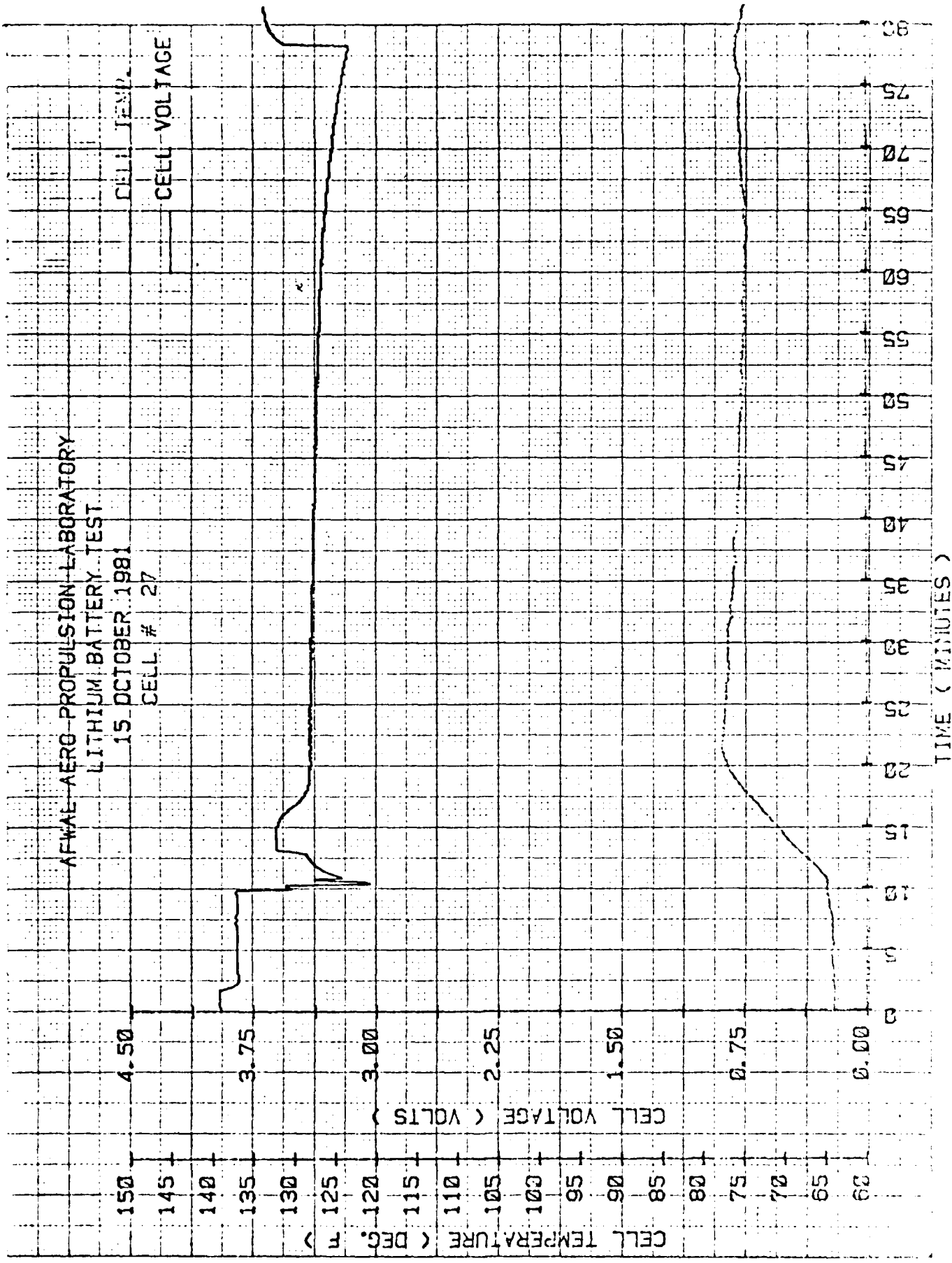

AFWAL AERO PROPULSION LABORATORY  
LITHIUM BATTERY TEST

15 OCTOBER 1981

CELL # 28

CELL TEMP.

CELL VOLTAGE

152 4.50  
145  
140  
135 3.75  
130  
125  
120 3.00  
115  
110  
105 2.25  
100  
95  
90 1.50  
85  
80  
75 0.75  
70  
65  
60 0.00

CELL TEMPERATURE ( DEG. F )  
CELL VOLTAGE ( VOLTS )

TIME ( MINUTES )

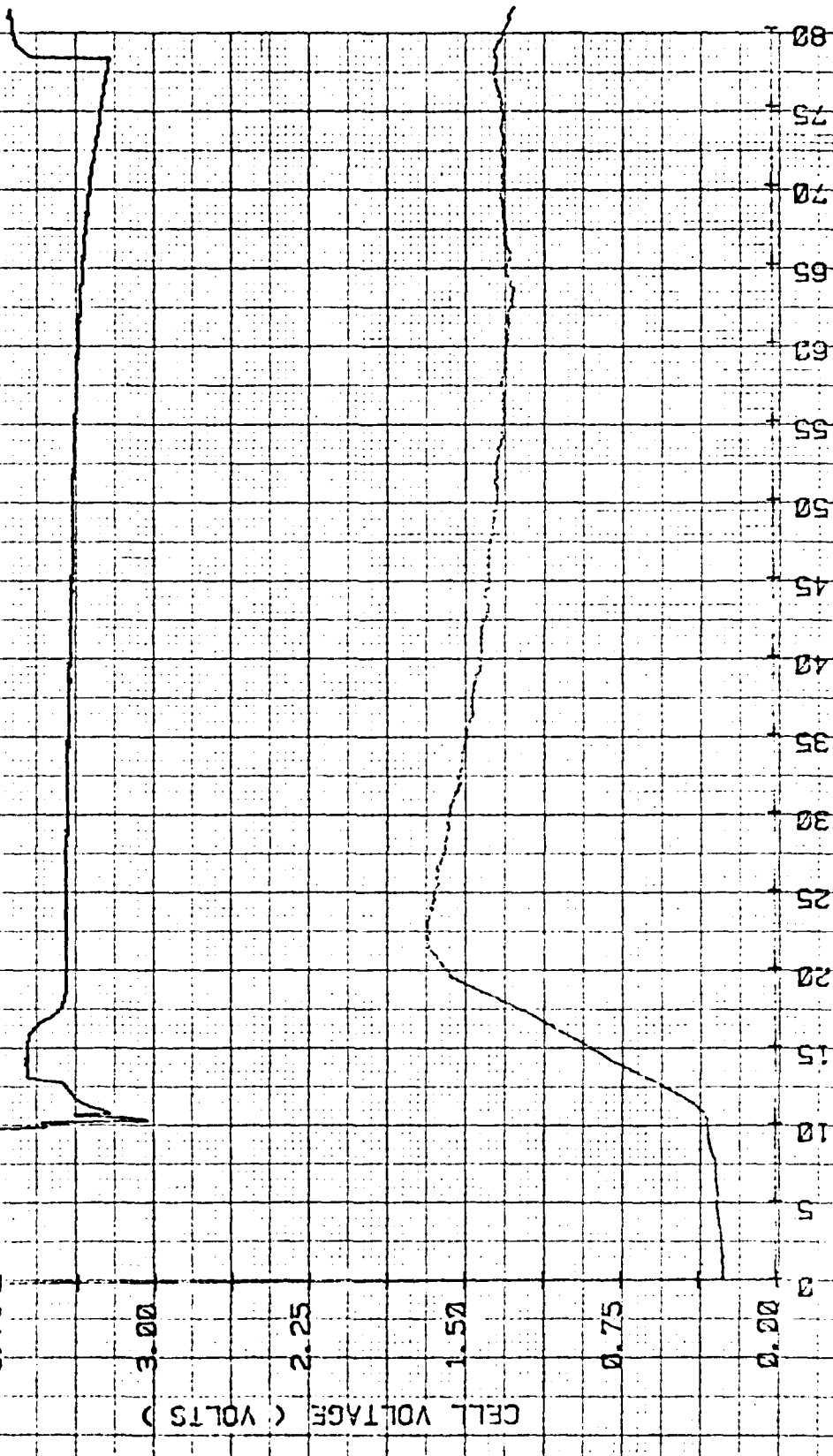

AFWAL AERO-PROPULSION LABORATORY  
 LITHIUM BATTERY TEST  
 15 OCTOBER 1981  
 CELL # 29

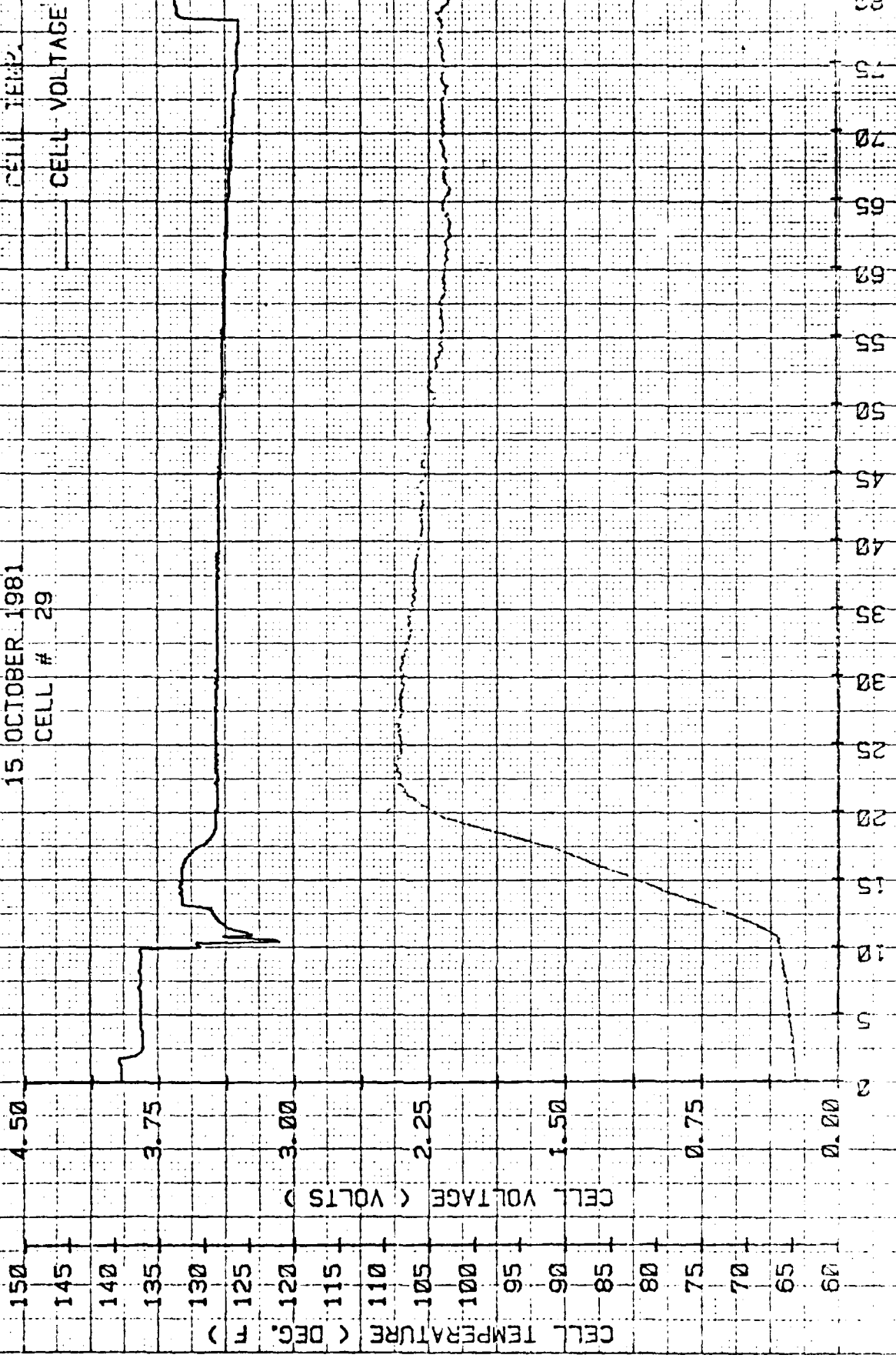

AFWAL AERO PROPULSION LABORATORY  
LITHIUM BATTERY TEST

15 OCTOBER 1981

CELL # 30

CELL TEMP

CELL VOLTAGE

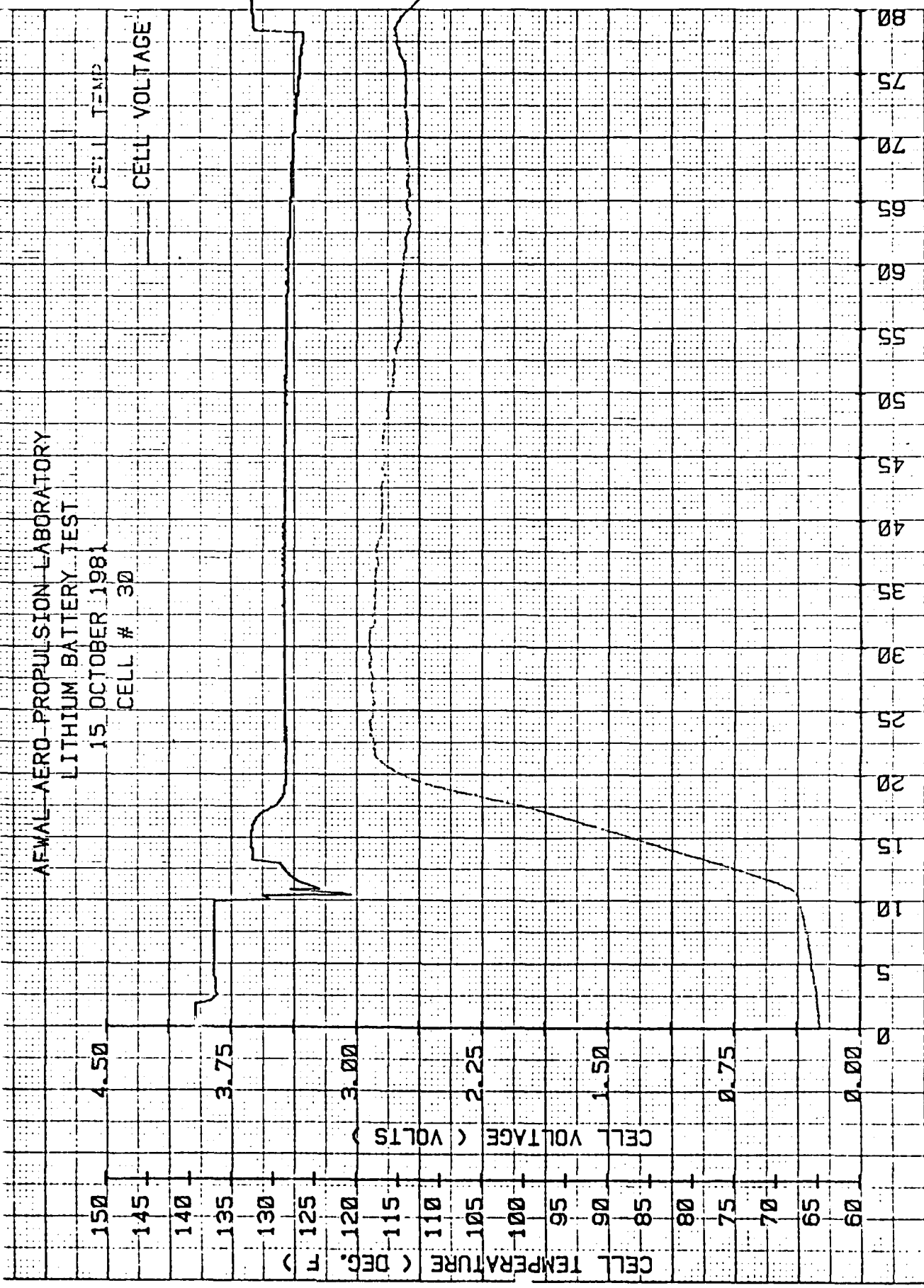

TIME ( MINUTES )

AFWAL AERO PROPULSION LABORATORY  
 LITHIUM BATTERY TEST  
 15 OCTOBER 1981  
 CELL # 31

CELL TEMP  
 CELL VOLTAGE

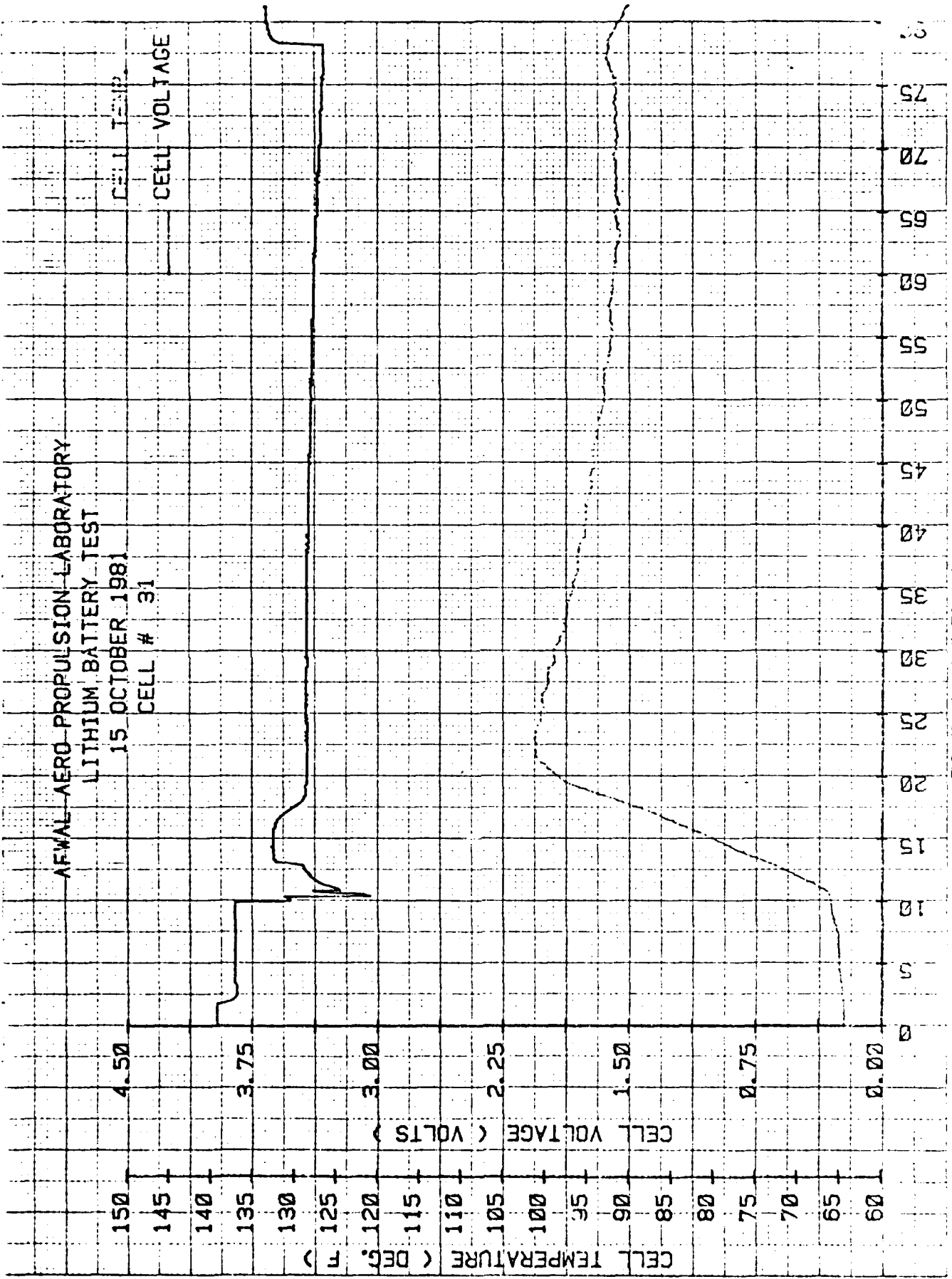

TIME ( MINUTES )

AFWAL AERO PROPULSION LABORATORY  
LITHIUM BATTERY TEST

15 OCTOBER 1981

CELL # 32

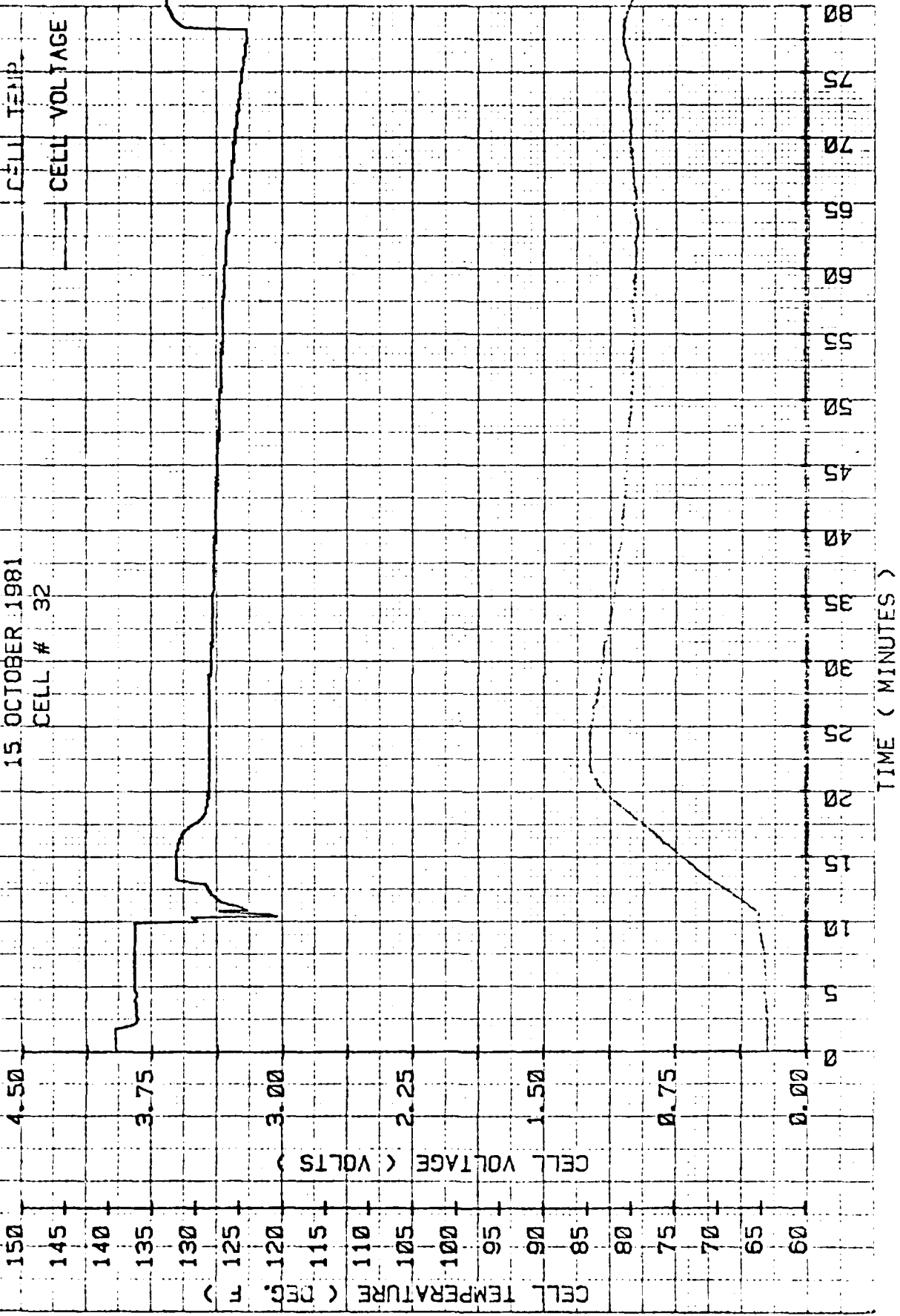

AFWAL AERO PROPULSION LABORATORY  
 LITHIUM BATTERY TEST  
 15 OCTOBER 1981  
 CELL # 33

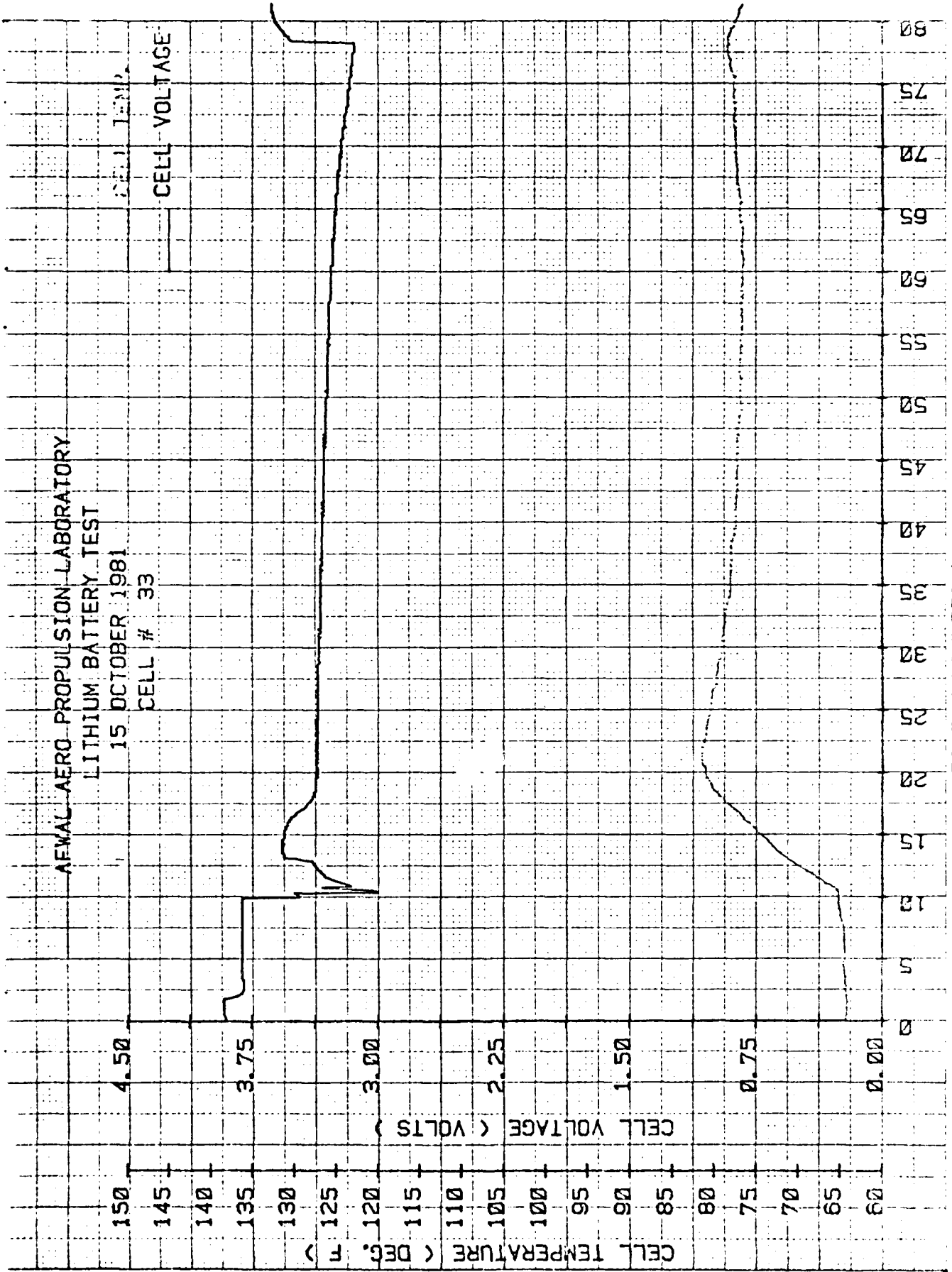

APPENDIX D

REVIEW TEAM INVESTIGATION OF ELECTRIC RPV MISHAP

AT EGLIN AFB, FL, 10 MAR 82

7 APRIL 1982

AD-A136 201

ELECTRIC REMOTELY PILOTED VEHICLE (ERPVI)(U) SUNDSTRAND  
AVIATION MECHANICAL UNIT ROCKFORD IL J O SMITH SEP 83  
ASD-TR-83-5014 F34601-80-G-0192

2/2

UNCLASSIFIED

F/G 10/3

NL

END  
DATE  
FILMED  
1 84  
DTIC

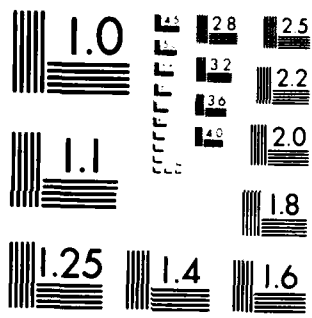

MICROCOPY RESOLUTION TEST CHART  
NATIONAL BUREAU OF STANDARDS-1963-A

REVIEW TEAM INVESTIGATION OF ELECTRIC RPV MISHAP  
AT EGLIN AFB, FL, 10 MAR 82

I. INTRODUCTION

A. Purpose

On 10 March 1982, a Remotely Piloted Vehicle (RPV), which consisted of XBQM-106 Airframe Tail Nr. 11 and a developmental electric propulsion system, crashed at launch at Eglin AFB, FL approximately 1½ seconds after leaving the launch rail. This vehicle was configured with the flight test electric motor and an interim silver-zinc high discharge rate battery for a final checkout flight before the flight with the developmental high discharge rate, long duration lithium thionyl chloride battery.

This developmental program has progressed under the sponsorship of the RPV Systems Program Office of the Deputy for Tactical Systems. Technical and facility support are provided by the Flight Dynamics Laboratory Aero-mechanics Division for the RPV and its flights, and by the Propulsion Laboratory for the developmental batteries.

The purpose of this review is to evaluate all available data and information pertaining to the mishap and to provide an independent assessment of the principle and contributing causes of the accident.

B. Team Composition and Charter

This Review Team was assembled at the direction of Brigadier General Richard E. Steere, Deputy for Tactical Systems, Aeronautical Systems Division (ASD), Wright-Patterson AFB, OH. Team members are assigned to the Deputy for Tactical Systems. These members are as follows:

Chairman: Franklin P Finizio, Deputy Director of Engineering  
Eugene L. Gross, Chief, Equipment Division  
Jack E. Wallace, Chief, Avionics Division  
I. Victor Yancey, Chief, Flight Systems Division  
Morris Means, Systems Integration Engineer, Directorate  
of Tactical Systems Integration  
David Jorgensen, ERPV Project Officer, Directorate of  
Tactical Systems Integration

The Team Charter, which was endorsed by Brig Gen Steere on 24 Mar 82, has a threefold purpose. The statement of the Charter is:

1. Investigate and report on the accident that occurred on 10 Mar 82 on XBQM-106. S/N 11 at Eglin AFB, FL.
2. Propose a plan for completion of the current Electric RPV program including identification of amount and source of funding.
3. Propose a long range plan for development of electric powered vehicle technology, including possible applications such as follow-on PAVE TIGER buys.

This report has been prepared to satisfy the first purpose.

## II. INVESTIGATION

### A. Summary

1. In addition to the silver-zinc or lithium thionyl chloride propulsion battery, the Electric RPV (ERPV) carries a 28-volt battery pack to provide power for the flight control receiver, the telemetering transmitter, the encoder/decoder, all on-board instrumentation, the wing leveler, and the flight control and throttle servo motors. This battery pack is assembled from 22 D-size nickel-cadmium rechargeable batteries. The batteries are wired in series and taped together in a compact cluster, then housed in a shop-fabricated aluminum box, or case, using an insulating foam blanket within the case and thin fiberglass sheets glued inside the cover to isolate the battery pack from its case.

2. The official mishap report reported that the principle cause of the accident was the shifting of the battery pack under the approximately 8g launch acceleration forces, causing contact with the avionics unit and causing a voltage spike to be sent to the flight control system (FCS). Contributing causes cited were that the technician failed to install the proper number of insulators when assembling the battery pack, and that the QC inspector failed to discover that an insulator was missing during preflight inspection.

3. The review team initially evaluated the official mishap report and the written statements of a number of test participants. The consistency of the documents' contents supported a single conclusion of primary cause and the identification of the contributing causes, although some inaccuracies (primarily in word choice) appeared in the official report. Subsequent discussions with Flight Dynamics Laboratory personnel and examination of the damage RPV supported the conclusion of the Preliminary/Final Mishap Report on the primary cause, but a different light was shed on some of the details.

4. Investigation revealed the battery pack had shifted within its case, and a cell at the 21-volt potential position had shorted against the cover of the battery pack. There is evidence that the technician had installed the thin insulating strip, but apparently the glue line failed, and the strip slipped out of the assembly. The battery pack had been assembled prior to the two-flight evaluation flown at Wilmington Airfield before departure to Eglin AFB, and it had not been disassembled at any time prior to the launch mishap. Examination of the interior of the battery case is not a preflight preparation step nor an inspection item.

5. The shorting of the 28-volt battery pack at the 21-volt level reduced its output to approximately seven volts. This voltage was insufficient to drive control receiver, telemetry transmitter, or fail-safe system. The low voltage signal at the servos drove the servos to position the ailerons and elevator for a left rolling descent, and to reduce the throttle to the idle setting.

6. At impact, or shortly before, the physical contact between the cell and the case of the battery pack was broken, and the short circuit cleared.

After impact, the telemetry transmission resumed, and a controller check showed the flight control surfaces responded normally, except for the left aileron and the rudder, which had been affected by the impact.

7. Extensive damage was done to the vehicle airframe except for the central portion of the fuselage and the empennage. The installed subsystems fared much better. The silver-zinc propulsion battery was damaged and the motor control electronics box was slightly dented. An attempt to run the motor (which was undamaged) caused an internal electric failure within its controller circuitry. With proper facilities, the vehicle can be repaired for continuing the flight test program.

8. The cause of the mishap should be considered a random failure, totally unrelated to the technology under development and test.

#### B. Discussion

1. The Electric RPV program was undertaken to prove the feasibility of a relatively silent electric propulsion system for RPVs which would enhance their use as battleground harassment vehicles in the counter-armor, counter-radar, and electronic warfare roles. A compact, high horsepower electric motor technology was mated to an extremely high power density, high discharge rate battery technology to provide propulsion for a vehicle in a practical weight range and for a practical area loiter endurance. In this particular test series, the standard RPV "truck" airframe, the XBQM-106 RPV, was modified to incorporate a 10 HP samarium-cobalt electric motor of relatively mature development and a sequence of two high-energy batteries. Silver-zinc battery technology is mature and this battery produces high energy levels for a short time. In this test vehicle, this battery provides power for takeoff, climb and cruise for a total of ten minutes. This battery, which is rechargeable, has been used for developmental flights to check out the performance of the test vehicle with the electric motor and mated propeller and to tune the vehicle subsystems for the eventual flight with the non-reusable lithium thionyl chloride battery, which can provide approximately 1½ hours of endurance. This is a developmental, preproduction configuration battery with highly reactive components and requiring special environmental safeguards during loading of the electrolyte and in disposition of the spent battery after flight. Because of the requirement for robotic removal and disposition of the unstable spent battery, Eglin AFB was selected for flight tests of the RPV with the lithium thionyl battery, since such a robot was available.

2. The XBQM-106 is launched from a pneumatically-powered launcher which has effective rail length of 31½ feet. Assembly, preflight preparation and checkout of test vehicle and ground systems are scheduled over a minimum of a four-hour period before launch. A published procedure is used for accomplishing and verifying the required steps, safety procedures, range safety, and operation of the radio uplink and downlink communications (flight controller radio transmitter and telemetry (TM) receiver and antenna systems on the ground, and controller radio receiver, TM transmitter and antennas in the vehicle).

3. The official mishap report and four witness statements were studied and the following sequence of events was derived:

VEHICLE ASSEMBLY:

Vehicle assembly began at 0800 and continued through 0900. Assembly was normal and in accordance with established procedures.

PRE-LAUNCH ACTIVITY:

a. Vehicle was placed on launcher at 0930, launcher was positioned at edge of runway pointed South. Wind was out of the North (downwind launch direction).

b. Preflight vehicle checks on ground power were performed, beginning at about 1000.

c. All RPV systems were reported to be functional, including flight control system (FCS), wing leveler, Telemetry Set (TM), and fail-safe control system.

d. All control van systems were checked and found to be performing normally.

e. Ground power (lead-acid battery) was applied to the motor at about 1030. Motor RPM, voltage, and throttle response all checked in normal ranges.

f. Ground range tests of radio flight control and TM were checked satisfactorily on the day before launch.

LAUNCH ACTIVITY:

a. The silver-zinc flight battery was installed at 1200. All systems were switched to internal power. FCS & TM were normal.

b. The motor was activated, and a full power run-up (5800 RPM) was made. FCS checked to be normal in operation. Motor was returned to idle RPM awaiting launch clearance.

c. At 1208, launch clearance was received. Motor RPM was brought up to 5800 RPM during five second count down.

d. Normal launch was initiated at approximately 1208. Launch acceleration was approximately 8g's.

e. Immediately upon departing launch rail, all control of the vehicle was lost.

f. Duration of flight was approximately 1½ seconds, and vehicle traversed approximately 100 feet, then slid inverted and additional 300 ft.

g. During the  $1\frac{1}{2}$ -second flight, the following occurred:

(1) The vehicle entered a moderate left roll and pitched slightly down. This maneuver is indicative of almost full left aileron and slightly down elevator.

(2) The pilot commanded full right rudder, full right aileron, and full up elevator and held these control inputs till after impact.

(3) The RPV continued the roll and descent until impact. The motor was reported to have gone to idle RPM by the time the vehicle left the launch rail.

(4) All RPV TM was lost for approximately four seconds after launch. All TM resumed operating after impact. Initial post-impact TM showed battery pack output voltage was increasing toward 28V.

(5) The "Fail-Safe" flight control inputs (idle RPM, right rudder and slightly up elevator for a descending right spiral) were never activated.

4. The launch crew and participating engineers immediately examined the crashed RPV. Whereas the official mishap report stated the RPV was totally destroyed, the personnel associated with the program pronounced the vehicle as severely damaged. The silver-zinc battery ruptured on impact and was immediately removed from the vehicle for safety reasons. It was mounted on the panel facing the camera.

28-Volt Control Power Battery Pack:

- a. Burnt spot was found on one cell of battery pack at the 21-volt potential level position.
- b. Insulator at lip of battery pack cover was missing.
- c. Burnt spot was found on same lip of battery pack cover.

Motor and Motor Controller:

- a. Motor turned freely with no apparent damage.
- b. Dent was found in top of controller chassis.
- c. No apparent damage was found inside the chassis.
- d. Resistance measurements at motor controller power input terminals were found to be within limits.

- e. Attempt to apply power to motor created a short circuit within controller circuitry.

Telemetry and Controller Radio Links:

- a. TM downlink transmission continued after impact until vehicle switches were manually turned off.
  - b. Operation of controls by controller uplink was attempted. Throttle, elevator and right aileron responded normally. Rudder did not respond. Left aileron servo was disconnected by impact.
5. When the vehicle and components were returned to WPAFB, the Laboratory personnel examined the battery pack assembly. It was noted that the thin fiberglass strip which had been glued to the one lip of the cover had lost adhesion at some unknown time after initial assembly of the battery pack and the aluminum cover was deteriorated. In an attempt to duplicate the conditions of the mishap, a deliberate short was introduced by soldering a wire to the burnt spots on the battery pack cell and the case cover. Immediately, the elevator, throttle and right aileron moved to the positions for pitchdown, idle RPM and left roll, respectively, as had happened during the launch accident.

C. Analysis

- 1. The Review Team studied the official mishap report and the written statements or reports of four test participants. These are identified as follows:
  - a. Official Class C Missile (RPV) Mishap Preliminary/Final Report, Eglin AFB, AD/SE 182230Z Mar 82
  - b. Accident XBQM-106 Tail #11, 10 Mar 82 at Eglin AFB, FL. Post-Crash Failure Analysis; Larry Linder
  - c. Electric RPV Launch, 10 Mar 82; Donald L. Lowe, Pilot
  - d. Electric RPV Crash, 10 Mar 82, Report on Status of Motor; Dennis T. Faulkner & Greg Hopkins, Sundstrand Corp
  - e. Electric RPV Accident Report, 10 Mar 82, at Eglin AFB, FL; Kenneth L. Bonnema, Co-Pilot

In addition, a visit was made to the Flight Dynamics Laboratory Aeromechanics Branch RPV facility. Contact was made here with Laboratory personnel (AFWAL/FIMS) Kenneth Bonnema, Dean Miller, Jim Cline and Perry Pitts. The damaged vehicle and the battery pack were examined and discussed. These personnel were of the opinion that the vehicle could be repaired and flown again. A summary of these discussions follows:

a. Ken Bonnema:

Mr. Bonnema provided the information that the battery pack was assembled and installed in the vehicle before the first of two flights at Wilmington Airfield and had not been disassembled until after impact in the subject mishap. Thus, this would have been the third flight since assembly of the battery pack and case. He noted that the battery pack was not an item of pre-flight inspection.

The reason given for the use of the aluminum case was that the previous support contractor normally fabricated fiberglass cases, but the support contract was not in effect during the Electric RPV program. The Laboratory personnel preparing the vehicle had no equipment for fabricating a fiberglass case and resorted to fabricating an aluminum case and providing insulating materials.

b. Dean Miller:

Dean Miller explained the configuration of the thin fiberglass sheets in the battery pack case cover. The three pieces (inside the top and two ends) were installed using Crazy Glue, a commercially available, instantly adhering adhesive. One of the two end strips was missing. He compared the aluminum battery case to the molded fiberglass battery cases previously used. While not discussed with Mr. Miller at the time, there is a possibility the fiberglass strip might have lost adhesion to the lip and slipped out of the assembled battery case. Mr. Miller subsequently confirmed that this was the most plausible possibility, since he knows it was installed originally.

Mr. Miller described the "fail-safe" maneuver in which the ailerons are commanded for a right bank, the elevator is commanded a few degrees up, and the throttle is retarded to idle. The maneuver is a gliding, right spiraling descent, the elevator deflection providing a positive angle of attack to maintain a gentle descent speed. Mr. Miller also described the operation of the servomechanisms which position the FCS surfaces and the throttle. This helped to establish the normal mode of operation and the response to degraded power levels.

The servomechanism device is a small rectangular box with a movable lever to which a rod is attached to drive the control surface. This lever is moved by an internal electric motor. The angular position of the lever is obtained by the response of the motor to the modulated electrical voltage from the encoder/decoder unit. There is no spring-driven return to a neutral position. The angular position is held until a subsequent voltage pulse is sent to the electric motor within the servo.

In noting that the shorted cell was at the 21-volt potential level of the battery pack, Mr. Miller indicated the battery pack was still capable of delivering six to eight volts to the systems. The positions taken by the servos at this power output were the results of the voltage signal received at each servo with the encoder/decoder operating at 6-8 volts. The controller receiver probably did not have sufficient voltage to receive and process signals from the pilot's controller.

c. Jim Cline:

Mr Cline showed the battery pack and explained its configuration. He also explained the locations of the several components in the main portion of the fuselage. It was noted that the battery pack could be forced to move about 1/8 inch fore and aft inside the case. Mr. Cline pointed out that the short circuit had occurred at the very edge of the heavy tape surrounding the battery pack.

d. Perry Pitts:

Mr. Pitts explained and demonstrated the functioning of the wing leveler system. The system uses a fluidic sensor coupled with the aileron and rudder servos to restore the vehicle to a "wings level" and near zero yaw attitude when the pilot neutralizes aileron and rudder control inputs. This function is necessary because the pilot may be unable to identify visually the bank angle or the yaw angle of the vehicle at the altitudes and distances of flight under some adverse light conditions.

2. All five documents reviewed were consistent in their content with respect to events and conditions, observed and deduced, beginning with and subsequent to the moment of initiation of launch of XBQM-106 Nr 11 on 10 Mar 82 at 1208 hrs at Eglin AFB, Fl. The evidence of a burnt spot on a cell of the battery pack, the loss of the TM data for the period of flight, the increasing voltage trace at the beginning of the post-impact TM data, and the failure of the FCS surfaces to respond to controller inputs or to go to the fail-safe position are all consistent with the test team's finding and conclusion that the 28V battery pack produced severely reduced output power during the period of flight, possibly 6-8 volts. This battery pack provided all electrical power to the vehicle except for the power to drive the propulsion motor. The 28V battery pack powered the FCS controller receiver, the encoder/decoder (which converted the radio signals into control voltages to the FCS surface and throttle servos), the on-board instrumentation system, the fail-safe system, the wing-leveler system, and the TM downlink transmitter. The interruption of the TM signals indicates loss of power to the TM transmitter. If we assume loss of a controller signal to the encoder/decoder, then the failure of the FCS surfaces go to the fail-safe position and the retarding of the throttle indicate loss of power to the encoder/decoder until after impact. The subsequent laboratory demonstration of the effects of the suspected short circuit provided adequate confirmation that partial interruption of electrical power output from the 28V battery pack was the direct cause of the mishap.

3. The contributing causes are defined as follows:

a. A short circuit between one cell near the high voltage end of the battery pack and its case (vehicle ground) reduced the power output from the battery pack to about 6-8 volts.

b. Loads on the battery pack under the 8g launch acceleration shifted the internal cells of the battery pack aft, permitting contact between the surface of one cell and the adjacent surface of the battery pack case cover, creating the short circuit. No contact occurred between the case of the battery pack and any other avionics components.

c. Absence of an insulating spacer permitted contact between one battery cell and the battery case cover under the launch acceleration forces.

d. Absence of the missing spacer was unnoticed by the technician who packaged the battery pack and installed it in the RPV, or it may have fallen out of the case assembly during or after one of the prior two flights. (The technician is certain that he glued the spacer in the cover at the time of assembly.)

(NOTE: This spacer was not found with the vehicle nor with the vehicle equipment at the launch site.)

4. It is noted that there are minor variances between the findings noted above and the text of the official mishap report. The official investigation was apparently somewhat brief and did not have the advantage of the "second look" which this Review Team had. The following subparagraphs correct some of these variances:

a. The mishap report statement in Section 9, "The acceleration g-load at launch caused the battery to shift position and short out the avionics package," appears to be a slight misinterpretation of what happened. The forces caused the battery pack to shift within its case, shorting out some of the cells and permitting only sharply reduced voltage to be applied to the avionics package terminals.

b. Section 10B states that technicians failed to install a required insulator. There is also a distinct probability that the insulator had been installed and had worked loose and had fallen out during or after one of the two prior flights flown since the battery pack had been assembled.

c. Section 10F makes reference to the preflight visual checklist. The reference to proper positioning of the internal battery appears to be consistent with the investigator's concept that the battery case shifted and contacted the avionics unit. The battery pack and case assembly were not checklist items because it is not disassembled between flights.

d. Finding Nr. 1 of Section 11 refers again to a failure to install the missing insulator without considering the second probability that

the 20 mil thick insulator had become unglued and slipped out of the assembly.

e. Finding Nr. 3 of Section 11 is a restatement of the Section 9 comment addressed in paragraph 4.a. above, except that the "short" involving the avionics package is said to have caused a "voltage spike" to be sent to the flight control system.

f. Finding Nr. 4A also reflects the investigator's concept of the battery case moving in the compartment and contacting the avionics unit.

5. The official mishap report makes two recommendations, which will be addressed here.

Recommendation 1: Recommend an inclusion to the maintenance and preflight visual checklist to verify proper positioning/insulation of the internal nickel-cadmium battery.

Action: ASD

Recommendation 2: Recommend a re-evaluation of the flight termination system (fail-safe) to preclude any situation that would allow continued uncontrolled flight.

Action: XBQM-106 Manufacturer, General Dynamics.

a. Recommendation 1 pertains to the positioning of the battery pack case and to the installation of the proper number of insulators. The "positioning" has been shown above to reflect a slight misconception on the part of the investigator. With respect to the installation of insulators, it is expected that the Laboratory personnel will repackage the battery pack to preclude physical contact between the battery cells and the aluminum case and cover. This will obviate the need to require a preflight inspection item, but the intent of the recommendation will be met.

b. The flight control surfaces of this vehicle are positioned by servo motors which respond only to electrical power inputs of controlled voltage. The fail-safe system is designed to control the aircraft and command a slow descending right spiral in the event the radio signal from the ground pilot is lost or if the uplink receiver fails to function. When electrical power to the encoder/decoder and servos is lost or degraded, there is no mechanism available to countermand the last signal to the servos. Therefore, it is not practical to comply with this recommendation.

#### D. Conclusions

The following conclusions are drawn as a result of the investigation conducted by the Electric RPV Review Team:

1. The electric propulsion technology development/demonstration flight test of XBQM-106 Tail Nr. 11 with a samarium cobalt electric motor and interim silver-zinc high discharge rate battery crashed during and attempted launch takeoff for the following reasons:

a. A fiberglas insulating strip, measuring approximately 4" x 1/2" x 0.020", was missing from the lip of the cover of a shop-fabricated aluminum case for the 28-volt battery pack. This strip may not have been installed at the time of assembly, but more probably, it became unglued and slipped out of the assembly during or after one of the two prior flights.

b. Under the 8g launch acceleration forces on the mishap flight, the taped cluster of the battery pack shifted aft within the case, and one cell at the 21-volt potential level made physical contact with the unprotected lip of the cover, creating a short circuit at that potential. The cells above that potential could provide an output voltage of only six to eight volts.

c. At this sharply reduced voltage, the controller uplink receive and telemetry downlink transmitter failed to perform their functions. The flight control system (FCS) fail-safe mode also failed to perform its function. The encoder/decoder passed through to the FCS control surface and throttle servos low voltage signals which commanded the motor to idle RPM and the surfaces to position for a pitchdown and left roll. With this control configuration as the vehicle left the launcher rail, the vehicle rolled to the left and descended below the intended flight path until it struck the ground.

2. The cause of the mishap has no relationship to the technology being developed and demonstrated.

3. The fiberglas fuselage of XBQM-106 Nr. 11 can be rebuilt and its systems can be refurbished.

APPENDIX E  
LITHIUM THIONYL CHLORIDE BATTERY FLIGHT TEST DATA

BATTERY POTENTIAL - VOLTS D.C. 0 25 50 75 100  
MOTOR CURRENT - AMPS D.C. 0 20 40 60 80 100

BATTERY ACTIVATION START

ONE MINUTE  
TIME

OFFSET 01 MIN.

STARTED MOTOR  
LOW SPEED ~ 800 RPM

CHART 1  
PAGE 1 OF 3

STARTED MOTOR  
LOW SPEED ~ 800 RPM

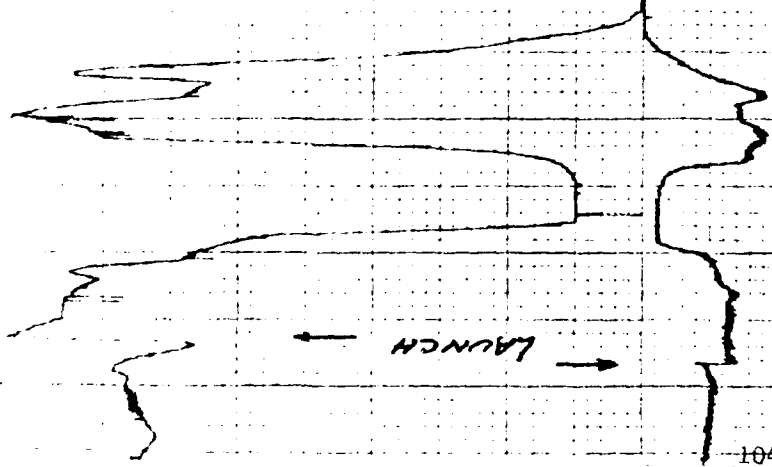
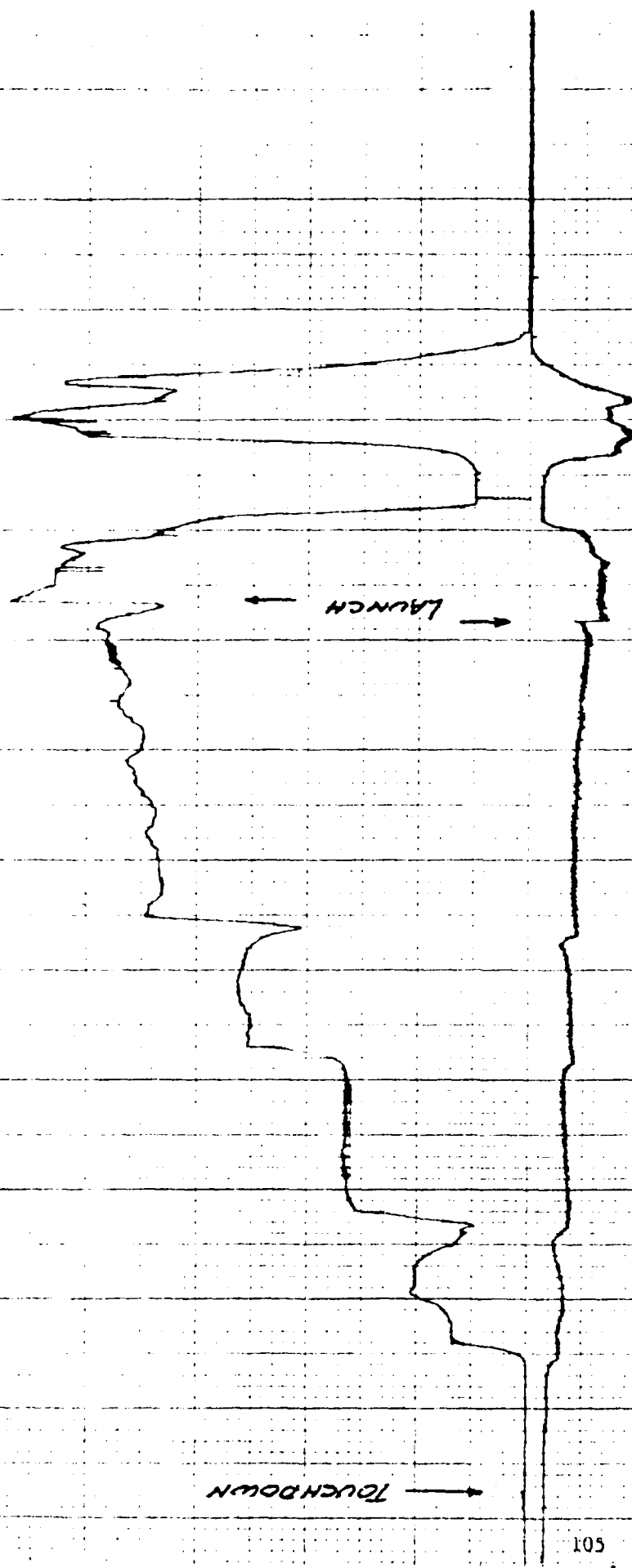

CHART 1.  
PAGE 2 OF 3

10000



TOUCHDOWN →

← LAUNCH →

105

CHART 1  
PAGE 3 of 3

00000

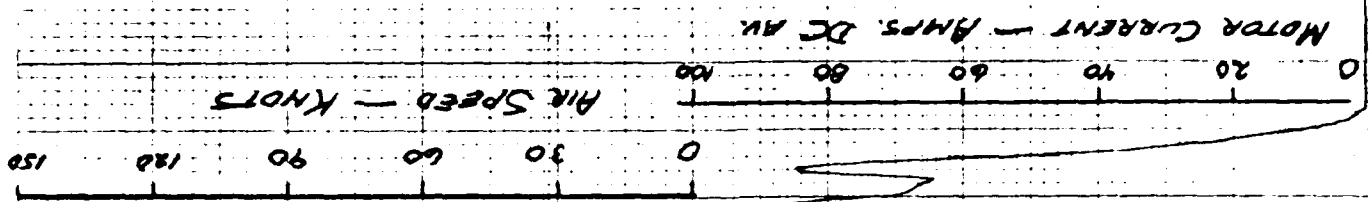

LAUNCH →

ONE MINUTE  
 TIME  
 OFFSET — 0.1 MIN.

TOUCHDOWN →

CHART 2.  
 PAGE 1 OF 1

MOTOR CURRENT - AMPS DC M. 0  
2K 4K 6K 8K  
R.P.M.  
0 20 40 60 80 100

STARTED MOTOR  
Low Speed  $\approx$  800 RPM

ONE MINUTE  
TIME

DIFFERENTIAL

CHART 3.  
PAGE 1 OF 2

ONE M.

T.

OFFSET

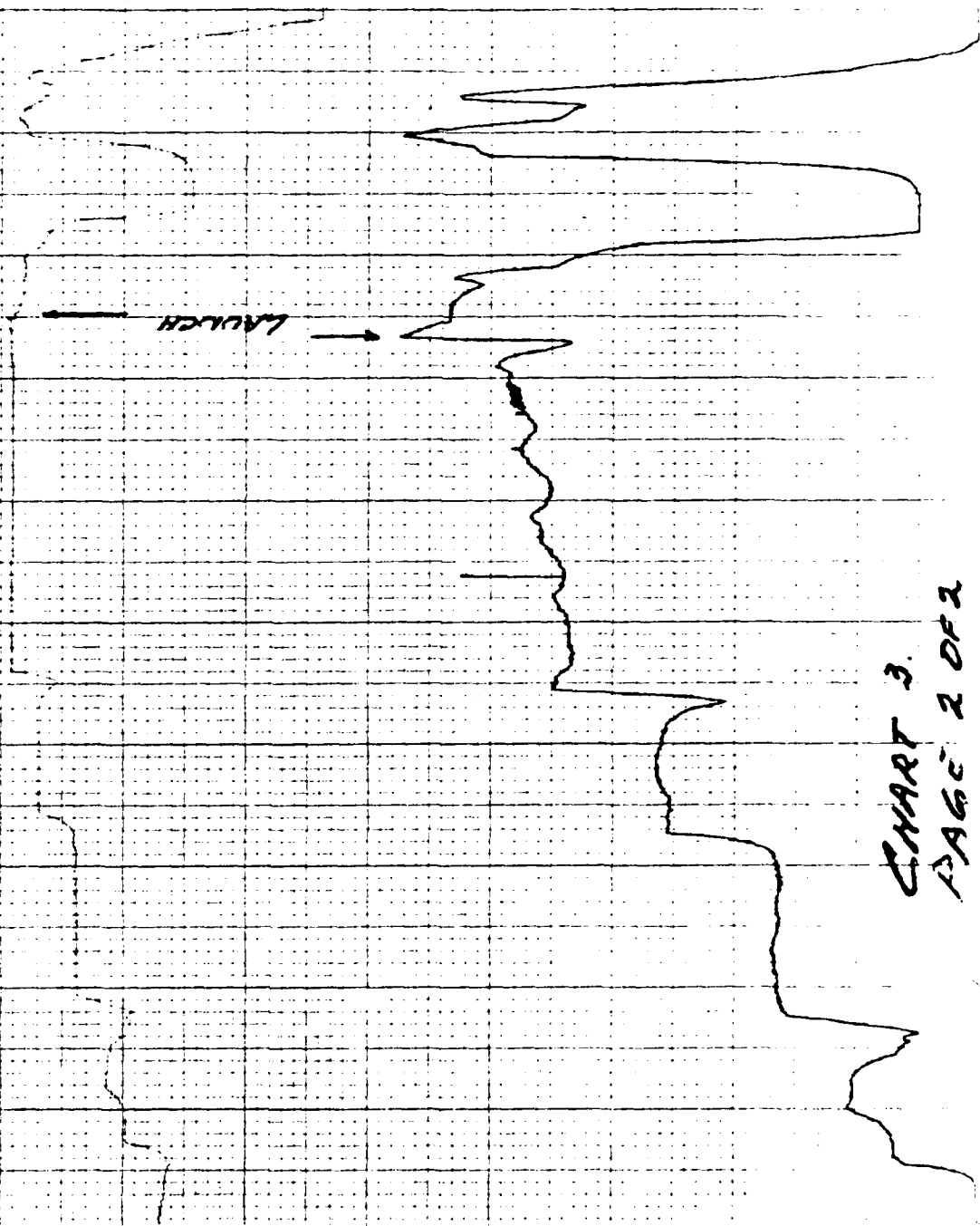
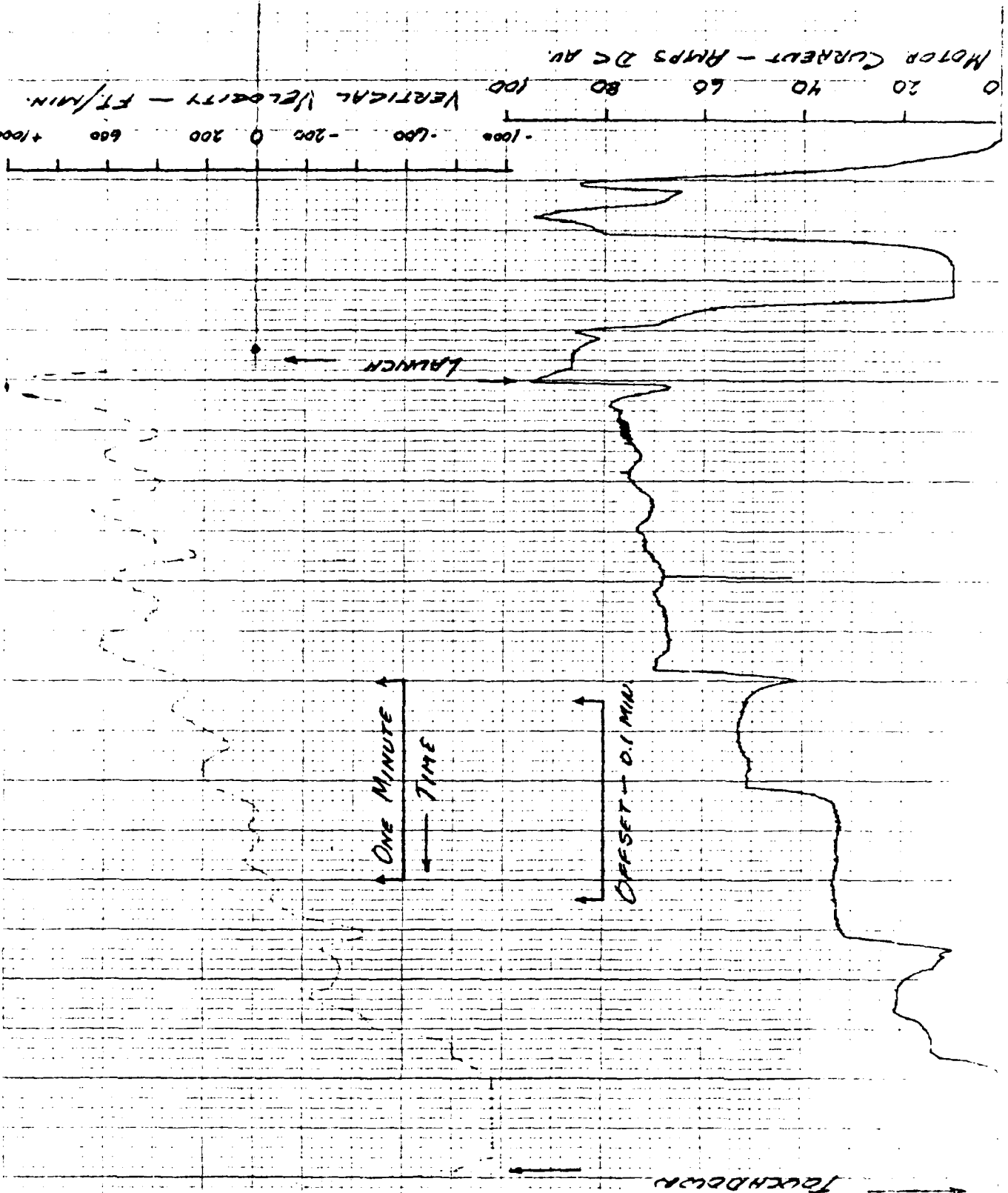

CHART 3.  
PAGE 2 OF 2

108

TOUCHDOWN

1  
2  
3  
4  
5  
6  
7  
8  
9  
10  
11  
12  
13  
14  
15  
16  
17  
18  
19  
20  
21  
22  
23  
24  
25  
26  
27  
28  
29  
30  
31  
32  
33  
34  
35  
36  
37  
38  
39  
40  
41  
42  
43  
44  
45  
46  
47  
48  
49  
50  
51  
52  
53  
54  
55  
56  
57  
58  
59  
60  
61  
62  
63  
64  
65  
66  
67  
68  
69  
70  
71  
72  
73  
74  
75  
76  
77  
78  
79  
80  
81  
82  
83  
84  
85  
86  
87  
88  
89  
90  
91  
92  
93  
94  
95  
96  
97  
98  
99  
100



LAUNCH 4  
TAKE-DOWN 1000

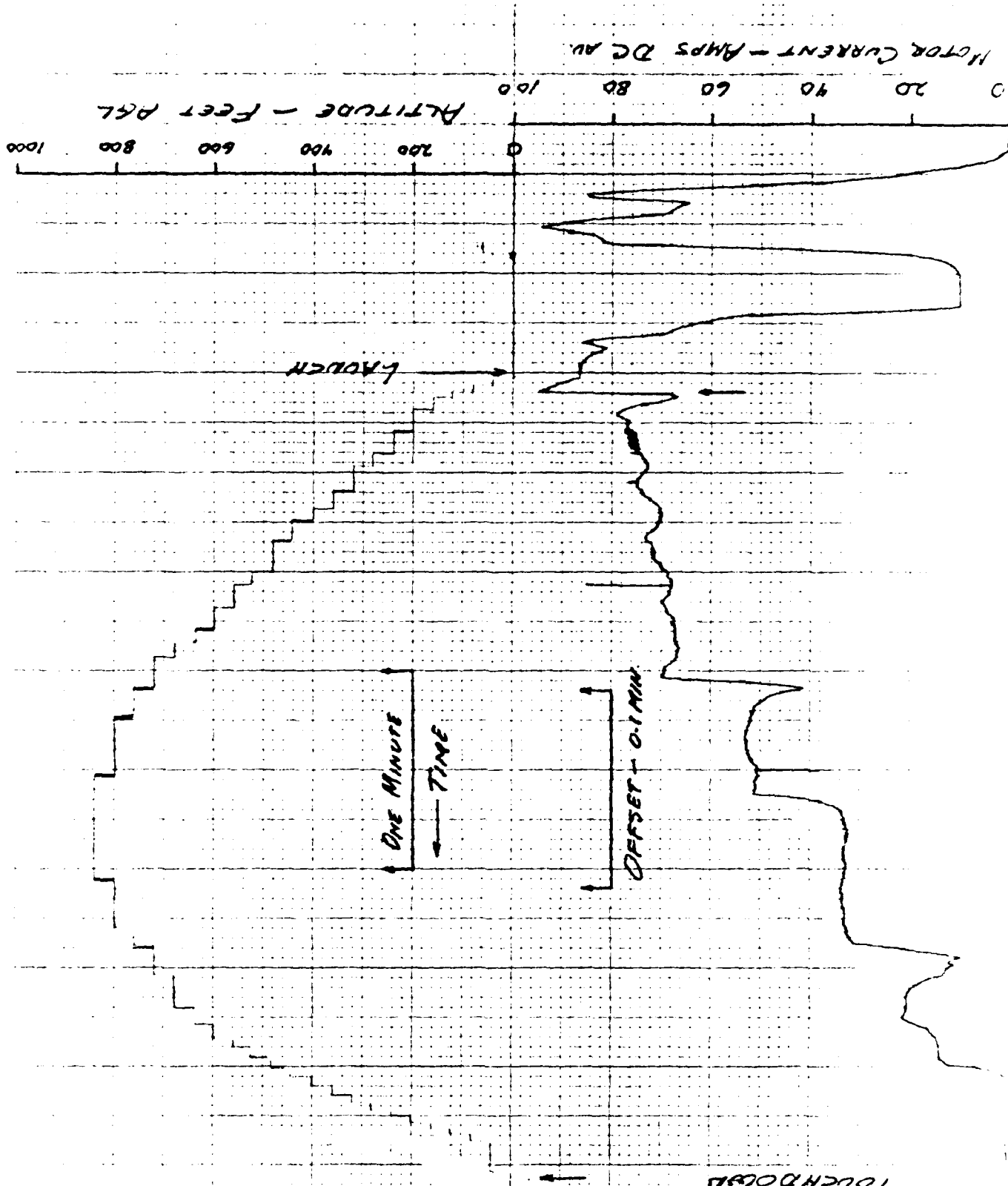

TOUCHDOWN

Chart 5  
 1001

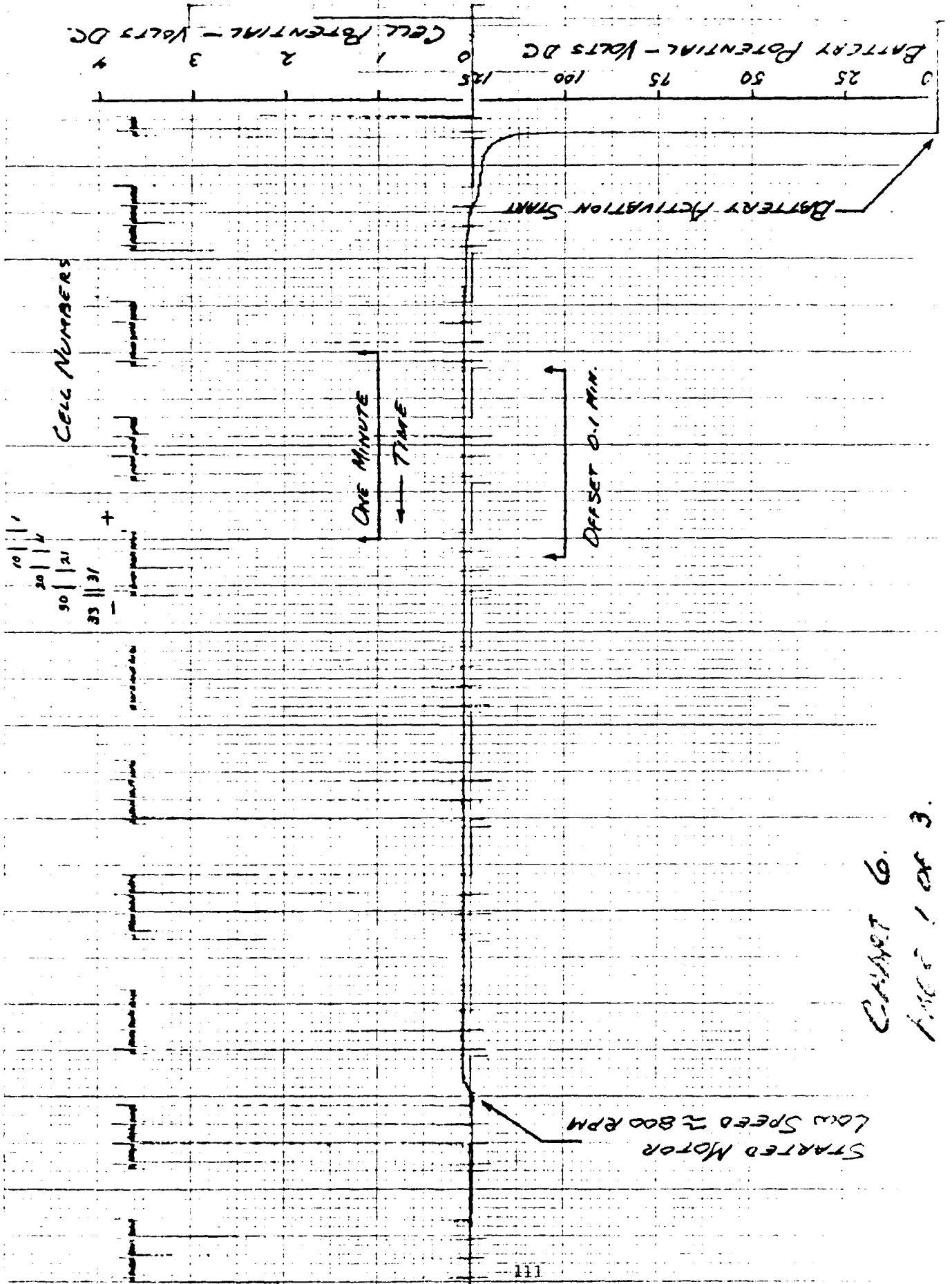

CHART 6.  
PAGE 1 OF 3.

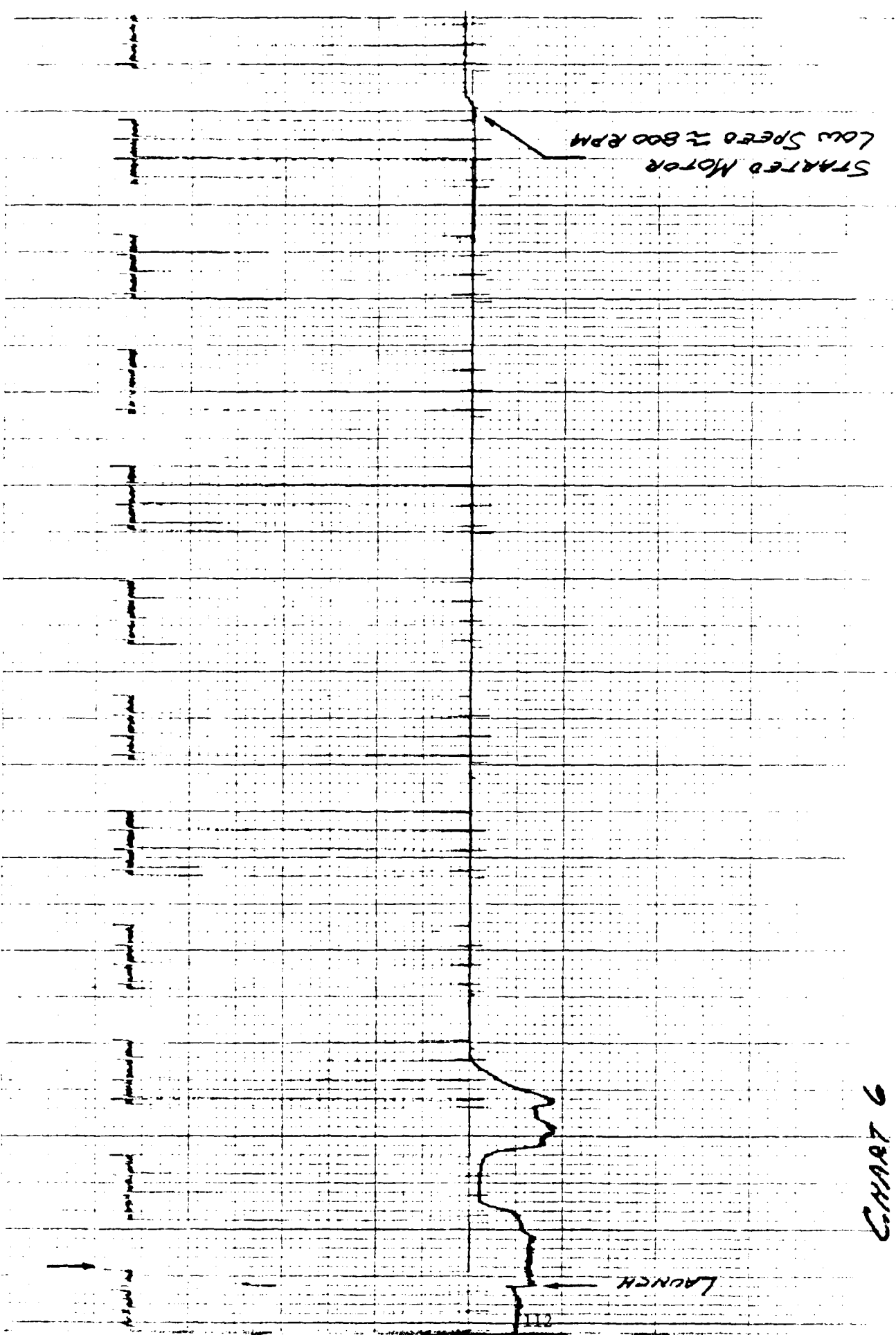

CHART 6  
PAGE 2 OF 3



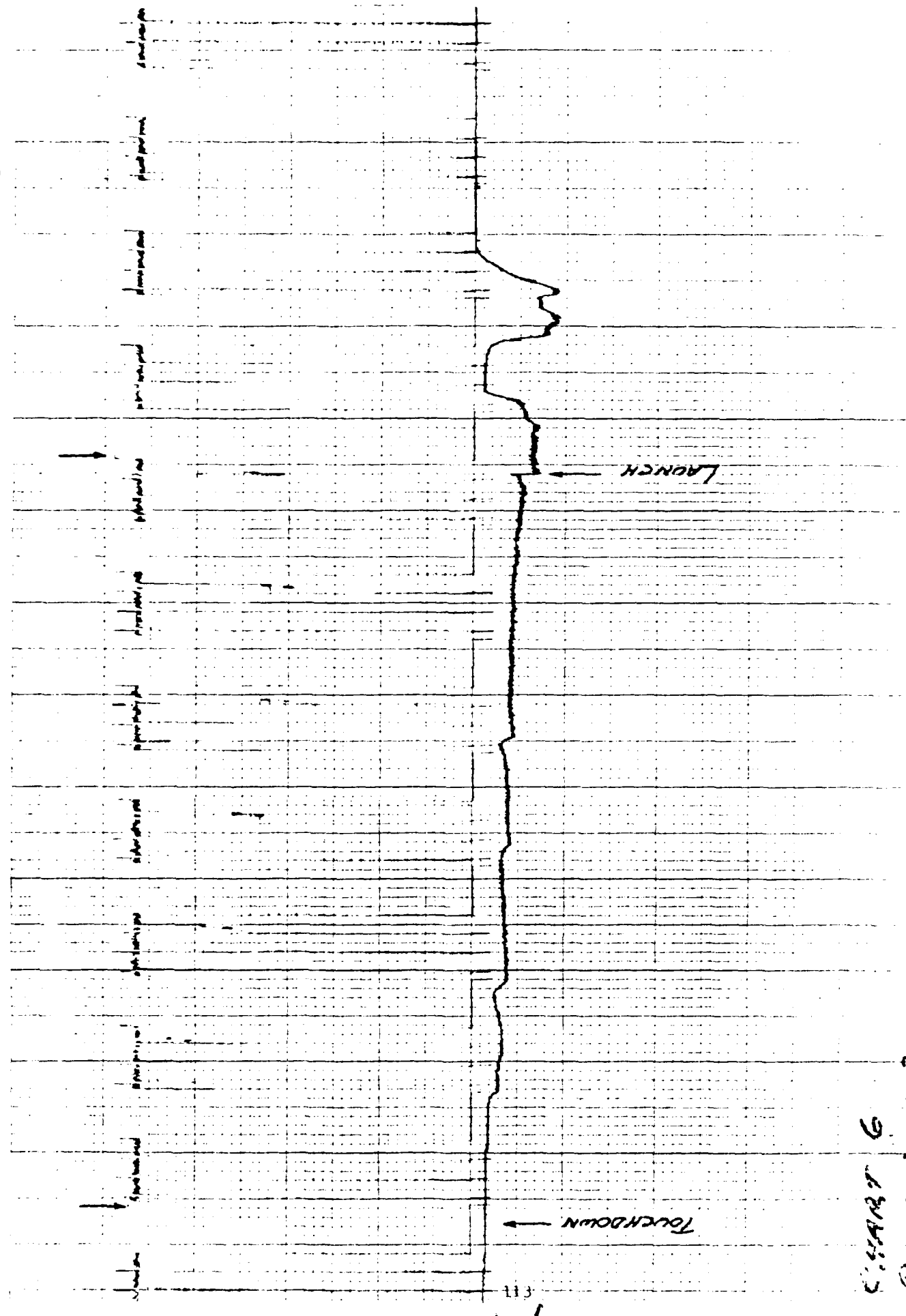

CHART 6  
PAGE 3 of 3

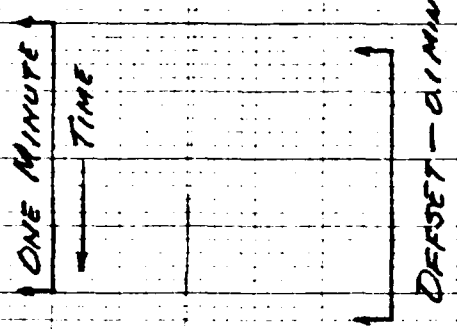
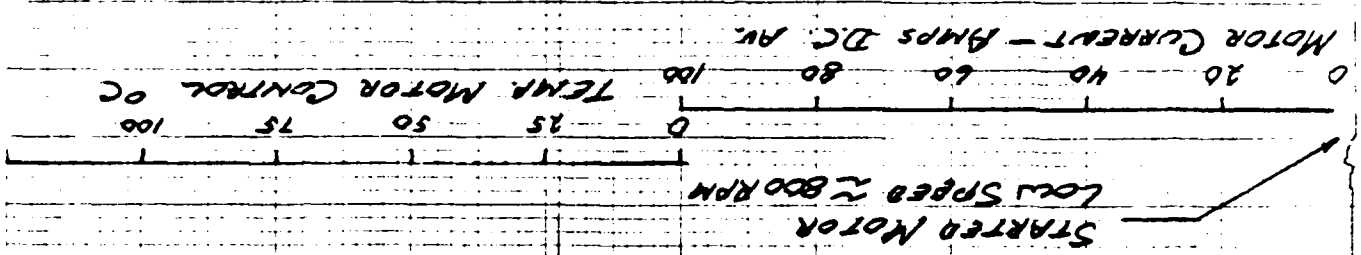

CHART 7.  
PAGE 1 OF 2

→ LUNCH

LAUNCH →

→

TOUCHDOWN ←

1000  
1000

BATTERY POTENTIAL - VOLTS DC  
 0 25 50 75 100 125  
 ① TEMPERATURE - LI. BATT °C  
 0 25 50 75 100 125

BATTERY ACTIVATION  
 START

ONE MINUTE  
 TIME

OFFSET - 0.1 MIN.

STARTED MOTOR  
 LOW SPEED ~ 800 RPM

CHART 8  
 10-3

3 JAN 1 1964  
CHART B

STARTED MOTOR  
LOW SPEED ~ 800 RPM

LAUNCH

TEMPERATURE DC LI BATT

711

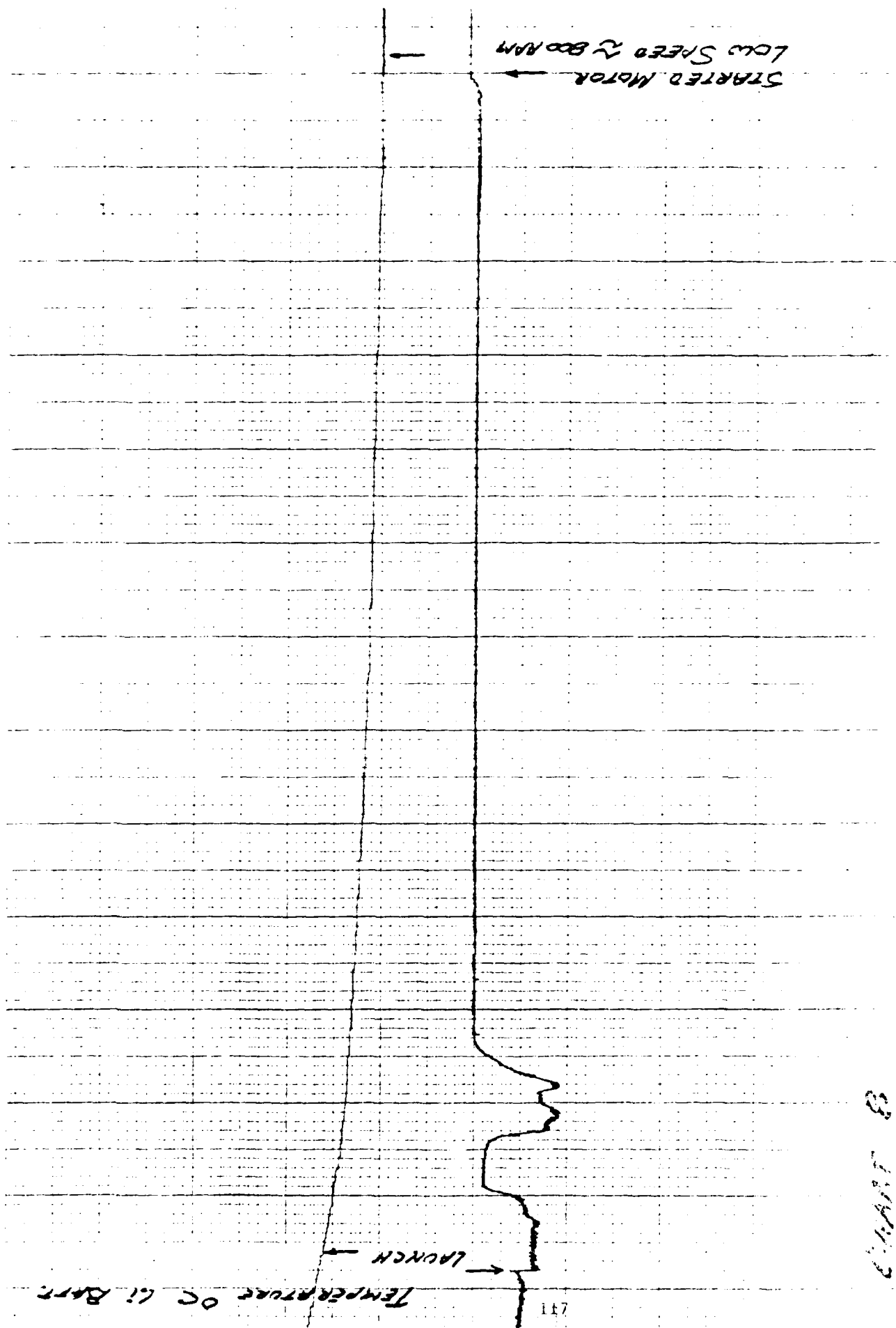

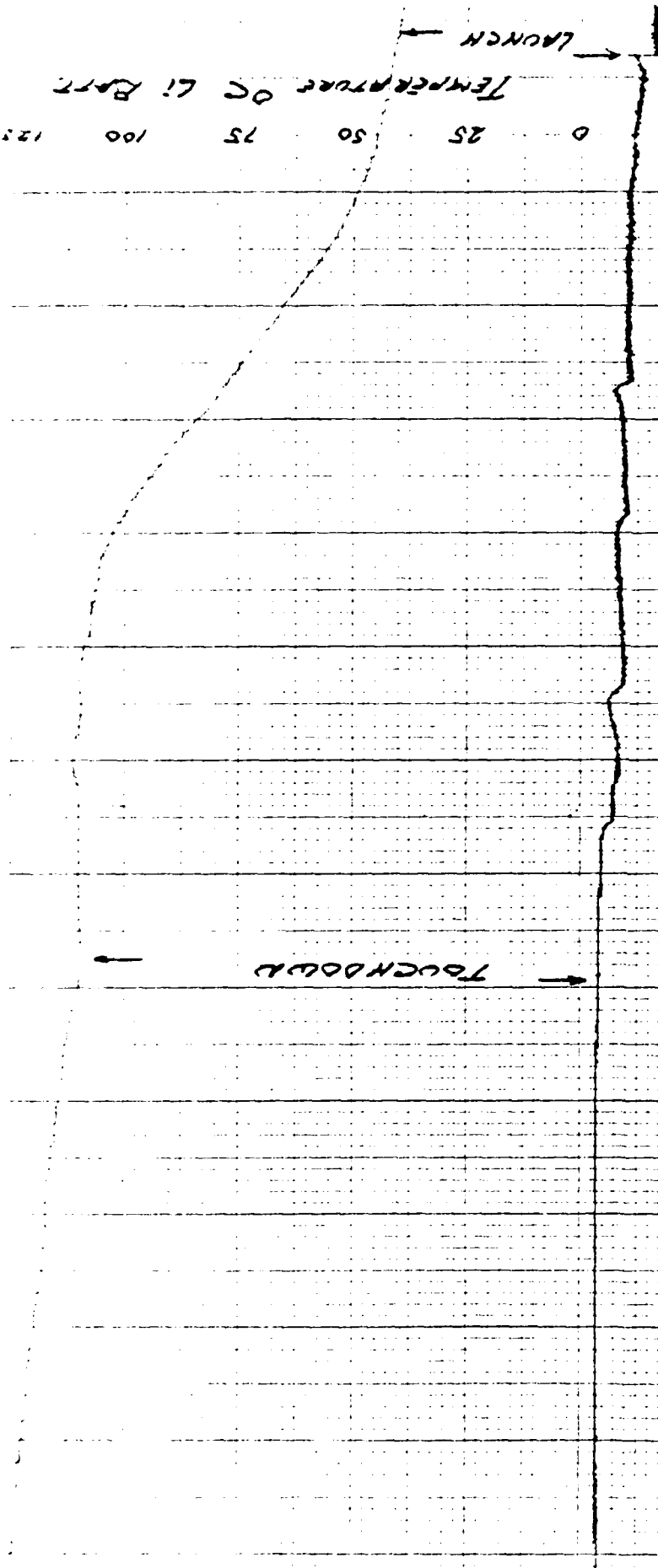
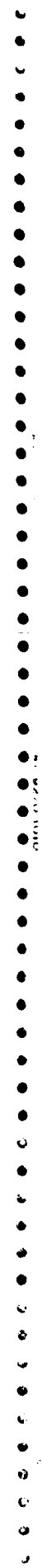
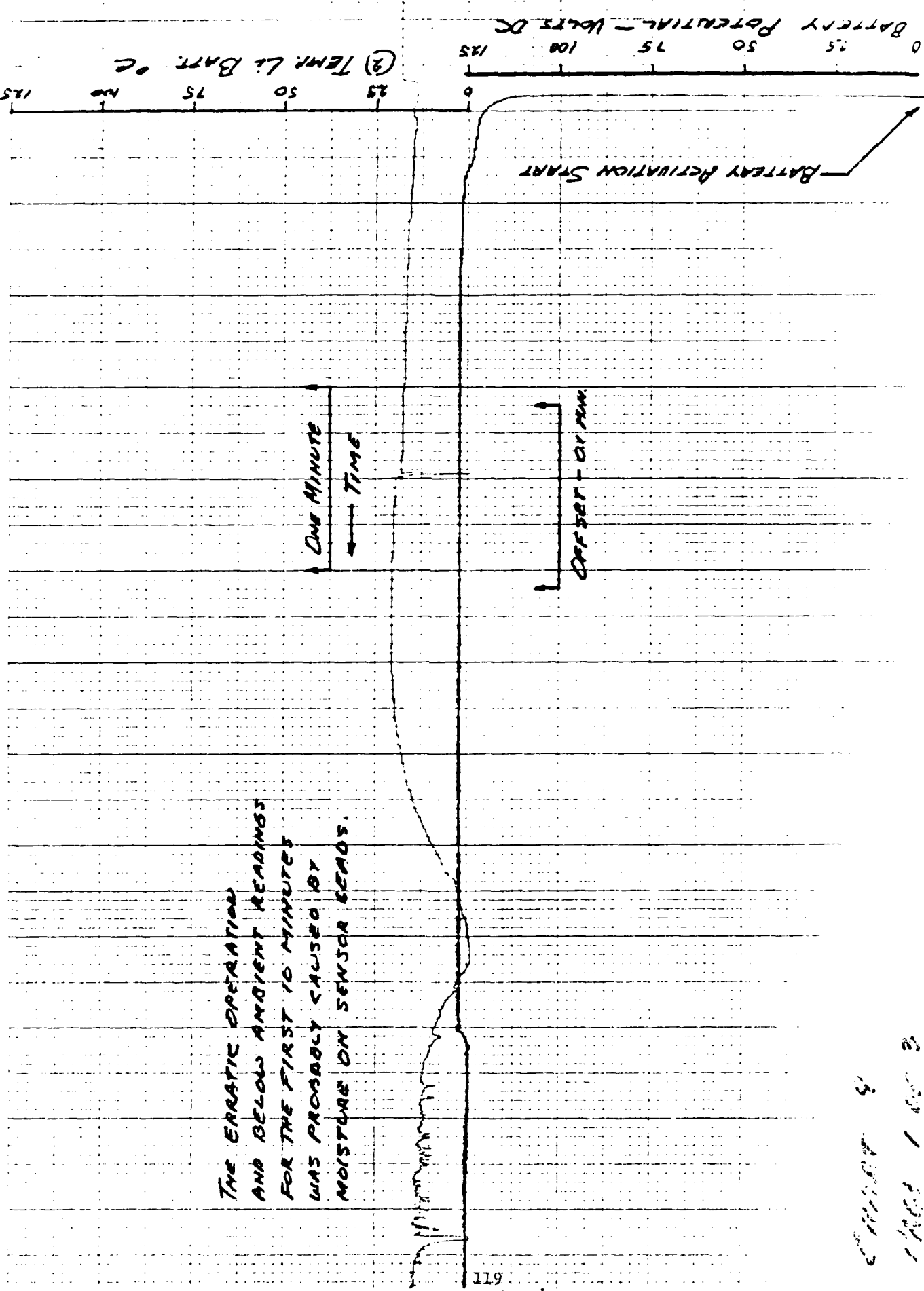

CHART B  
PAGE 3 OF 3



119



3  
1 1 2



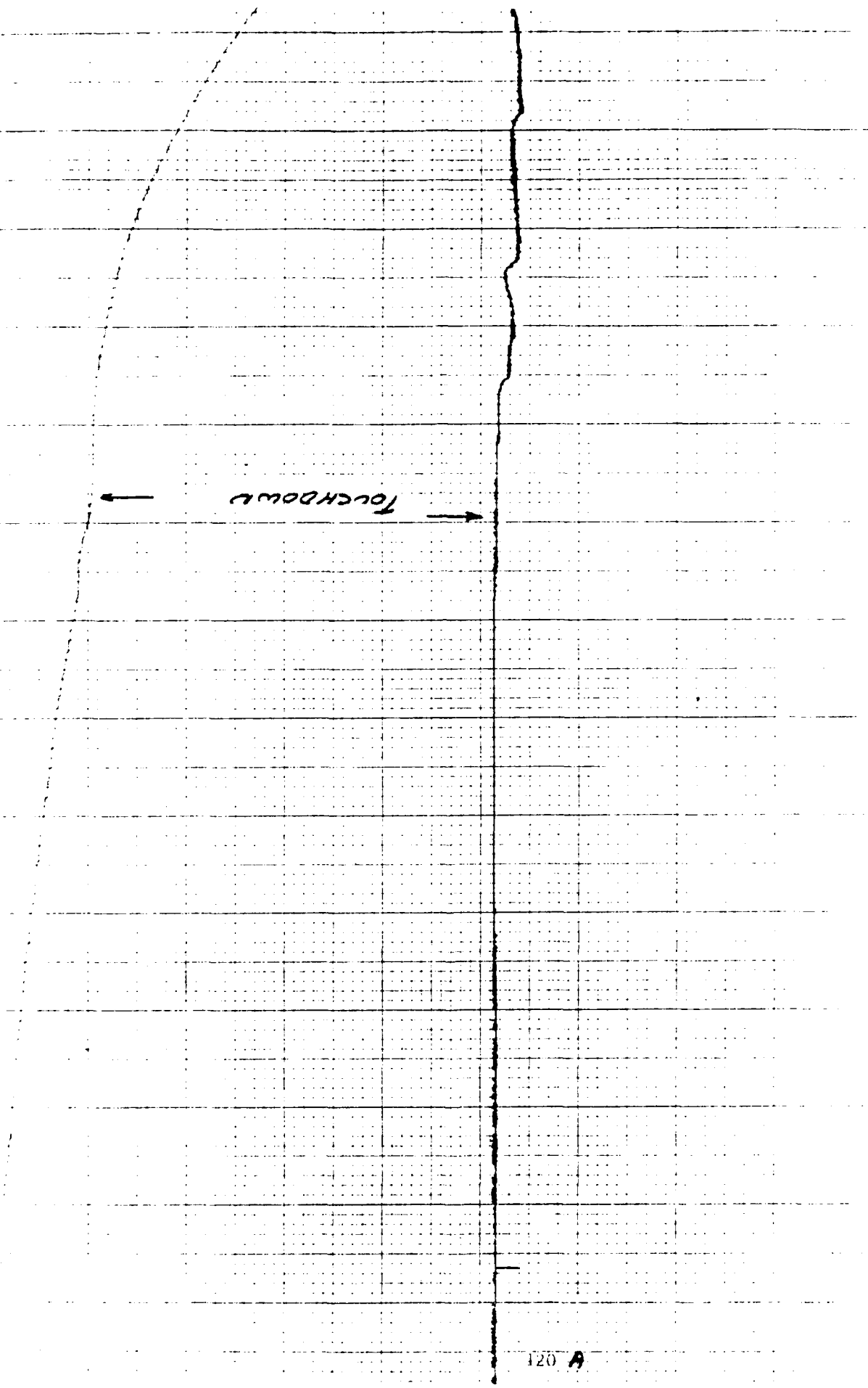

Chart 9  
Page 2 of 2

APPENDIX F

ELECTRIC REMOTELY PILOTED VEHICLE

FLIGHT TEST PLAN

## INTRODUCTION

1. For more than a decade, designers have been interested in developing an Electric Remotely Piloted Vehicle (RPV). The advantages of this system are:

- a. Reliable instant start and relatively low life cycle cost.
- b. Excellent storability characteristics (reserve activated batteries and electric motors can be stored five to ten years).

The advantages of the RPV are:

- a. Expendable mission support flights, surveillance, jamming, or kamikaze-type missions.
- b. The system offers very low observables in IR, RF, acoustic, and visual at operational altitudes making it attractive over the forward edge of the battle area (FEBA).

2. The proposed system for the Electric RPV is a Lithium Thionyl Chloride battery driving a Samarium Cobalt brushless DC motor through a solid-state controller. The primary advantage of the proposed Lithium Thionyl Chloride battery is the extremely high energy density (200-300 wh/lb) as compared to Silver-Zinc (30-50 wh/lb).

3. The primary advantage of the Samarium Cobalt brushless DC motor is it is more energy efficient. The heat produced during use is generated in the power transistors of the electronic commutator and in the winding of the stator. This results in a smaller, lighter motor for the same energy output. This motor is desirable especially in this energy limited system.

### PURPOSE

To validate the concept of using an electrical propulsion system based on new advancements in battery and motor technology with an XBQM-106 mini-drone vehicle. This flight test plan will be used to evaluate the performance of the Lithium Thionyl Chloride battery coupled through an electronic solid-state controller to an advanced Samarium Cobalt brushless DC motor.



## RESPONSIBILITIES

1. The Program Integration (TAB) System Program Office (SPO) has overall responsibility for the E-RPV program. The SPO will provide planning and guidance for contractor and participating test organization or other government agencies participating in the test program. The SPO will provide a test manager to assume the duties as Test Director. The Test Director will have overall responsibility for the success and safe conduct of test during field operations. He will have final authority in all areas of coordination, countdown, launch and flight termination. "Field Operations and Test Countdown Procedures" are being developed which will identify test team personnel and their responsibilities during the test. Other organizational responsibilities are addressed in the following paragraphs.

2. ASD/TAB (Test Requester) will:

- a. Provide direct reimbursable funds to 3246 TW for estimated test costs.
- b. Arrange for technical support and services as required.
- c. Arrange for contractor's test activities as required.
- d. Develop an E-RPV test plan.
- e. Coordinate efforts by the laboratories for development of batteries and motors.
- f. Ensure that an investigation officer is designated to complete the final investigation and reporting in case of mishap.

3. AFWAL/FIMS - Mini-Drone Operations/Test - XBQM-106:

- a. Provide technical expertise for flight control and operations of the XBQM-106 test bed vehicle.
- b. Provide the test aircraft, ground drone control equipment, and ground instrumentation equipment.
- c. Integrate the motor/controller and battery into the test vehicle.
- d. Coordinate on E-RPV test plan.
- e. Ground test motor/controller and propeller.

4. The 3246 Test Wing will:

- a. Submit the required documentation necessary to contact the AD functional organizations that will support the E-RPV test program. Provide facilities and all necessary approvals for handling and disposal of the activated Lithium Thionyl Chloride batteries.
- b. Dispose of batteries at completion of test.

c. Provide the program planning and coordinate activities for the organizations involved with the E-RPV flight test preparations.

d. Coordinate on the E-RPV test plan.

e. Provide technical support, support facilities, and other test support services as required.

f. Prepare an initial report during any RPV accident or mishap investigation.

5. The following contractor support will be provided under separate contractual obligations:

a. Honeywell will:

1. Provide personnel and technical expertise to load and activate the Lithium Thionyl Chloride battery aboard the XBQM-106 prior to launch.

2. Provide Lithium Thionyl Chloride batteries required for flight testing.

3. Provide personnel and technical expertise to assist in the proper handling and disposal of the spent batteries.

b. Sunstrand will:

1. Provide brushless DC motor/controller for flight test.

2. Provide test data of bench testing to verify performance of motor/controller.

3. Make minor repairs to motor/controller as required.

4. Monitor testing of the motor/controller.

### RPV TEST PHASE

General: The RPV test phase will be divided into five (5) separate activities as follows:

1. Performance of controller and motor system external to test vehicles (Bench test).
2. 33-Cell Lithium Thionyl Chloride battery fill and activation procedures and ground test (Flight profile loads).
3. Motor/controller and propeller high-speed ground test using lead acid batteries to evaluate the propulsion system.
4. Vehicle performance data gathering flight tests using a Silver-Zinc battery.
5. Vehicle full endurance flight test with a Lithium Thionyl Chloride battery.

1. PHASE 1 - PERFORMANCE OF CONTROLLER AND MOTOR SYSTEM EXTERNAL TO TEST VEHICLE (Contractor-supplied data)

The objective of this test is to characterize the controller and motor system performance. The motor contractor will do this testing at his facility.

The suggested method is to mount the motor and controller on a dynamometer or other rotary load device. Using a DC power source as an input to the motor, accumulate the following data:

- a. Torque vs. RPM
- b. Current vs. RPM vs. load
- c. Motor temp vs. load

2. PHASE 2 - 33-CELL LITHIUM BATTERY TEST (Contractor conducted test)

In Phase 2, the Lithium Thionyl Chloride battery will be tested at the Naval Weapons Support Center (NWSC), Crane IN. Purpose of this test is to obtain electrical battery performance data during an actual simulation involving battery activation, test to the actual flight profile, rapid removal of the battery from the RPV airframe, and the verification of safe disposal of the spent battery.

3. PHASE 3 - ELECTRIC MOTOR DYNAMIC AND PROPULSION TESTS

In Phase 3, the electric motor/controller propeller will be dynamically tested on the ground using an external DC power source. The motor/controller and propeller will be taxied at flight speeds while mounted on an automotive vehicle. Ground speeds of (60-80 mph) are achievable. See Attachment 1 for parameters to be recorded.

4. PHASE 4 - FLIGHT TEST WITH SILVER-ZINC (Ag-Zn) BATTERY

In Phase 4, the vehicle will be flight tested with an on-board Ag-Zn battery pack. See Attachment 2 for parameters to be recorded.

FLIGHT TEST PROFILE - This phase will be the first opportunity to evaluate the electric propulsion system in flight. It is not anticipated that the flights will last any longer than 15 minutes and knowledge learned from these flights will dictate the flight profile parameters and limitations for the Lithium battery flights. These flights will give the ground pilot an opportunity to evaluate throttle response and any other significant changes in the aircraft handling qualities.

5. PHASE 5 - FLIGHT TEST WITH LITHIUM THIONYL CHLORIDE BATTERY

In Phase 5, the vehicle will be duration flight tester with the Lithium Thionyl Chloride battery pack. The same parameters measured in Phase 4 will be measured in this phase. See Attachment 2.

## FLIGHT TEST PROFILE

### CONSIDERATION:

When operational data is available from Phase 4, a more definitive flight test plan can be finalized. Two actual flights will take place at Eglin AFB. The first flight will utilize a silver-zinc battery as the power source for aircraft flight verification. The other flight will utilize the lithium thionyl chloride battery. Two lithium thionyl chloride batteries will be available for the test. Lithium thionyl chloride batteries are not rechargeable.

Pilot of the RPV will at all times keep the aircraft in sight within safe gliding distance of runway and no farther than 1/2 mile away since the RPV will not be quipped with any tracking devices.

There will be constant monitoring of battery energy usage (watt hours) and at the time during the flight at which the watt hours expended reach the planned value, the aircraft will be landed. The probable flight period will be 1.25 hours.

See Table 1 for the planned flight profile of the XBQM-106.

ELECTRIC RPV  
XBQM-106 AIRFRAME

MAXIMUM ENDURANCE  
FLIGHT PROFILE 5S

SIMULATION TEST

	TIME MIN.	THRUST POWER		SHAFT POWER		BATTERY POWER		BATTERY ENERGY		APPROX. SHAFT RPM	AV/CY		BATTERY CURRENT AMP
		WATT	WATT	WATT	WATT	WATT/HR	KWH	POT.VOLT	AMP				
1. LAUNCH ENGINE RUN-UP	0.42	--	--	2400	2400	16.7	0.017	VAR	122.1	19.7			
2. CLIMB TO 200 FT AGL 600 FT/MIN @100 FT/SEC ON RADIUS TO CIRCLE	0.33	5356	7673	8974	8974	49.4	0.066	6700	109.0	82.3			
3. 90° TURN TO CIRCLE 500 FT RAD. FLAT 100 FT/SEC, -5.8° ELEV.	0.13	2855	3614	4518	4518	75.3	0.141	5500	120.5	37.5			
4. CLIMB ON 4500 FT DIA. CIRCLE 1/2 LAP TO 1200 FT AGL 500 FT/MIN @100 FT/SEC	2.1	4843	6726	7988	7988	279.6	0.421	6400	114.4	69.8			
5. CRUISE ON 4500 FT DIA. CIR @1200 FT AGL 65 MPH - 95.4 FT/SEC	EST 64.3 to 99V	2189	2781	3621	3621	3881.	4.30	5214	109.7	33.0			

TABLE 1

## SAFETY

1. The goal of the Electric Remotely Piloted Vehicle (E-RPV) test program is to accomplish the objectives stated in this plan without accident or incident. E-RPV "Field Operations Procedures" will be developed to detail steps and operations necessary for the safe conduct of the E-RPV. This detail procedure will cover vehicle assembly, launcher, ground control station preparation, preflight, battery preparation, launch, in-flight, battery disposal, and emergency procedures. Any deviation from the test plan or procedures will not be tolerated except where unexpected occurrences compromise safety.

2. Where applicable, ground tests will be accomplished to assure proper operation of the E-RPV systems.

3. AD Safety Officer has been designated the primary safety representative during field testing. The safety officer shall assure that the following items are accomplished:

a. Insure all safety reviews are accomplished prior to the flight test.

b. Perform initial investigation and reporting on accidents. After initial mishap investigations and reporting actions are completed, ASD shall appoint a mishap investigation officer to complete the final mishap investigation and reporting.

c. Monitor progress of tests authorized in this test plan and insure that additional coordination and safety reviews are accomplished in the event tests not included in this plan are directed.

4. Other Safety Considerations:

a. Ground Safety: The Phase 5 energy source being used in conjunction with the electric motor is an advanced design Lithium Thionyl Chloride battery. Activating the battery requires insertion of the electrolyte into the battery cells. The following potential hazards are present during battery-activation operations:

(1) Rupture of the electrolyte container

(2) Electrolyte spill

(3) Overheating of battery, resulting in possible explosion and fire

(4) Dispersion of toxic gas/chemicals into the atmosphere could be harmful to human life in the event of immediate direct contact.

b. Flight Safety:

(1) The Lithium Thionyl Chloride battery poses unique problems if in the event of a catastrophic failure the vapors/gases/liquids resulting from a battery rupture or fire are allowed to contact personnel. In the event of toxic "off gassing," the minimal exposure limits in parts per million (PPM) established by the National Institute for Occupational Safety and Health (NIOSH) may be exceeded for personnel within 200 feet downwind of the "off gassing." Principle toxic contaminants are sulphur dioxide and sulfuric acid. Since the hazard is strongly dependent on concentration and direct exposure and does not have any persistent danger, selection of an isolated flight test site and

structuring of procedures (ERPV Field and Operations Countdown Procedure) which guarantee personnel protection/separation both on the ground and during flight provides a positive control. The following steps will also assure positive control.

(a) "Test Directive Safety Annex," 11 Sep 81, has been developed by the 3246 TW which establishes the safety criteria for the conduct of this test. The following safety precautions will apply to the flight test:

1. Protective clothing and special checklists/procedures will be used to preclude exposure of personnel to toxic materials.
2. The battery will be disposed of by EOD personnel after the test using a remote dud retriever.
3. The lithium battery will be activated remotely.
4. Only those personnel specifically authorized by the Safety Annex will be allowed within a safe distance of 40 feet from the RPV once the battery is activated. These personnel will wear protective clothing.
5. If telemetry data indicates a battery malfunction or if telemetry is lost, the battery will be treated as an armed, 55 pound TNT equivalent, explosive device.
6. The RPV will not be flown over ground personnel. Test Area B-12 will be closed to all personnel not associated with the mission.
7. The RPV will not be launched directly upwind from the pilot.
8. All nonessential personnel will be evacuated from the test area prior to battery activation.
9. After flight, the battery will be removed from the RPV using the dud retriever.
10. The RPV will be flown in the local vicinity of Site B-12 and will be in visual range at all times.
11. The RPV guidance system has a destruct mode which commands the RPV into a tight spiral if the command uplink is lost.
12. If the RPV becomes uncontrollable, the command uplink will be turned off.

(b) The "Field Operations and Test Countdown Procedures" will also contain emergency procedures to be followed if abnormal conditions exist during testing.

(2) Other Considerations: The following additional safety considerations should be noted:

(a) Explosives - Although no explosives are involved, the battery is considered an explosive hazard.

(b) Fuel - Not applicable

(c) Electrical - Airborne equipment other than the motor shall receive power from a 28 VDC conventional Ni Cad battery source. Only qualified personnel should be authorized to come in contact with the flight instrumentation set-up. Standard 110 VAC is used in test equipment. Normal precautions will be observed.

(d) Radio Frequency Emissions - The test article average radiated power density at the antenna face is less than ten mw per cm<sup>2</sup>.

(e) Aircraft Operation - The RPV must be operated in a safe manner due to the nature of the power source. The vehicle must remain in visual contact of the pilot during the flights.

c. The AD Safety Officer will insure that AD Range safety procedures are complied with and that the procedures proposed for the E-RPV test will minimize the risk to personnel and property. The Test Director is responsible for operational activities associated with the vehicle. All normal and emergency procedures will be initiated by coordinating with/through the Test Director.

ELECTRIC MOTOR DYNAMIC AND PROPULSION TESTS

TEST PROCEDURE: ACCELERATE VAN TOWARDS MPH POINT  
START MOTOR AND SET RPM  
HOLD VAN AND MOTOR SPEEDS FOR 5 SECONDS  
MOVE MOTOR RPM TO SUCCEEDING SETTINGS AND HOLD  
FOR 5 SECONDS EACH  
SHUT OFF RPV MOTOR DURING TURN-AROUND AND  
PREPARATION FOR NEXT PASS  
REPEAT TESTS FOR 24 1/2" AND 26" VERSIONS  
OF MODEL W26GXL13 PROPELLER

INSTRUMENTATION:

RECORDED DATA

THRUST	MOTOR VOLTAGE
TORQUE	MOTOR CURRENT
RPM	TRUE AIR SPEED
TIME SYNC	

MANUAL READOUT NOTATION

MOTOR TEMP  
VEHICLE VELOCITY

MANUAL RECORD

DIRECTION OF MOVEMENT  
TOTAL MOTOR ON TIME FOR EACH PASS

GROUND DATA RECORD

AIR TEMP	WIND DIRECTION
REL. HUMIDITY	WIND VELOCITY
BAROM. PRESSURE	

NOTE: THE REQUIREMENT TO INSTRUMENT MOTOR TEMPERATURE IS TO AVOID OVERHEAT OR TO WARD OFF POTENTIAL TROUBLE. ALSO MAKE PENCIL NOTE OF TOTAL MOTOR ON TIME IN SECONDS FOR EACH PASS.

ATTACHMENT 1

ELECTRIC RPV INSTRUMENTATION

REAL TIME  
TELEMETRY  
FROM VEHICLE

FLIGHT  
SILVER & LITHIUM BATTERIES

AIR SPEED  
VERTICAL VELOCITY  
ALTITUDE  
BATTERY LINE VOLTAGE  
MOTOR CURRENT (AVERAGE)  
PROPELLER RPM  
BATTERY TEMPERATURE  
MOTOR TEMPERATURE  
RAM AIR TEMPERATURE (OPT)

GROUND  
READOUT:

TIME OF FLIGHT  
ACCUM. KWH ENERGY USED  
T.M. DATA ITEMS (CALL UP READOUT)

ADDITIONAL DATA:

WIND DATA  
DIRECTION  
VELOCITY  
RELATIVE HUMIDITY  
BAROMETRIC PRESSURE  
TEMPERATURE, LOCAL AREA

ATTACHMENT 2

APPENDIX G

E-RPV FIELD OPERATIONS

and

COUNTDOWN PROCEDURES

## INTRODUCTION

### I SCOPE OF TESTS

The scope of this procedure is to detail the steps and operations necessary for the successful launch operations of the Electric Propelled Remotely Piloted Vehicle (RPV). It includes procedures for vehicle assembly, launcher preparation, ground control station preparation, preflight, battery preparation, launch, in-flight, battery deactivation and emergency procedures.

### II OBJECTIVE

The objective is to provide a detailed field operation and countdown procedure for the safe and efficient operation of the E-RPV flight test program.

### III PRINCIPLE OPERATIONS PERSONNEL

The following personnel are designated members of the test team. These people will be designated by name in the countdown procedure.

ASD:	John O. Smith Leon Stratis 1Lt Mary Sherman	Test Team Director (TTD) Project Engineer/Alternate Director Project Manager
AFWAL:	Ken Bonnema Dean Miller Perie Pitts Jim Cline Richard Marsh Irvin Luke Mel French Steve Vukson Jim Miller Jan Evans	Back-up Pilot Electrical Technician Project Engineer Launcher Operator Battery Project Engineer Battery Test Engineer Silver Zinc Battery Technician Asst Battery Project Engineer Computer Operator Computer Operator
HONEYWELL:	Kurt Garoutte Curtis Michener B. H. Harris	Li-Battery Project Engineer Li-Battery Technician Li-Field Test Engineer
SUNDSTRAND:	Pat Curran Bill Peterson	Motor Program Manager Motor Project Engineer
AD:	Sgt Thompson Ralph Reed Appropriate EOD personnel.	Test Engineer Safety Officer
OTHERS:	Don Lowe	Mini-Drone Pilot

#### IV COMMUNICATIONS

This field operations and countdown procedure standardizes communications and coordinates all personnel involved in the preflight and launch operations communications network. There are three (3) communication networks and many locations on each. This procedure will define each person's responsibility, verbal language, and responses required over the comm net for clarity and efficiency. The following examples will be utilized on the comm net, i.e.:

Control Van (Dean Miller)	-	"Miller, Control"
Launch Area (Don Lowe)	-	"Lowe, Pilot"

The TT Director will have final decision in all areas of coordination, countdown, and flight termination. The Director will ensure that all areas are manned and ready prior to the countdown. The Director will announce all countdown events and verify that the appropriate required actions have taken place before proceeding to the next event. Each person will respond to the Director when these actions have taken place. All persons have the right to hold countdown by declaring "Hold Countdown" over the comm net. At that time, the Director will determine the reason for the hold, decide solution for the hold, and determine when to proceed with the countdown.

#### V SAFETY

AD/SE will have the primary responsibility and authority for Range Safety. However, all participants are responsible for the safety of the flight test. All elements shall coordinate safety related decisions and assessments with the TT Director, Project Manager, and Safety Representative. A declaration of a hazardous condition by anyone shall be acknowledged and shall not be questioned until personnel safety is assured. Personnel safety is the highest priority area of safety. At no time shall personnel safety be sacrificed for equipment safety or expediency of the operation.

#### VI COUNTDOWN PROCEDURES

The countdown procedures will begin at T-6 hours prior to battery activation. Each member of the test team will be given a copy of the countdown checklist in order to follow the sequence. Emergency procedures will only be accomplished by order of the TT Director.

<u>TIME</u>	<u>EVENT</u>	<u>PERSONNEL</u>	<u>CHECK</u>
T-6 Hrs	A. <u>Vehicle Assembly</u>	* Bonnema, Lowe, Pitts	

The vehicle is assembled on a work stand near the launch rail in the following sequence:

1. Nine feet wing spar is installed in fuselage and secured with 8 allen head bolts.

\* Person responsible for the steps.

2. Horizontal Tail panels are installed through the vertical fin with a tube spar and an anti-rotation pin and secured with two allen head screws.

---

3. The left wing panel is slipped over the tube spar and mated to the fuselage, making sure that the aileron cable plug engages the plug in the fuselage. The wing is secured with an allen screw, and the wing fuselage joint is taped with vinyl tape.

---

4. The right wing panel is installed in a similar manner with the additional requirement that the static and pitot air lines must be connected to corresponding lines in the fuselage.

---

5. The motor cowling and air duct are installed and secured with eight button head screws.

<u>TIME</u>	<u>EVENT</u>	<u>PERSONNEL</u>	<u>CHECK</u>
T-6 Hrs	B. <u>Launcher Preparation</u>	Jim Cline	

The launcher and its tow vehicle should be aligned as nearly as possible into the prevailing wind, and with a clear paved landing area stretching at least 1500 feet straight ahead in case an aborted launch results in an immediate vehicle landing. The launcher will never be aimed at the wall area congregation of personnel and ground vehicles regardless of wind direction. If winds are 20 knots or greater and the launcher or recovery runway cannot be aligned with 45 degrees of the wind, the flight must be aborted until weather conditions are more favorable. The launcher is prepared as follows:

1. The launcher remains attached to its tow vehicle and is anchored by cranking its four extendable feet down to the ground. Each crank should be turned eight to ten turns after its foot has reached the ground.

---

2. Protective tarpaulins are removed from the launch rail and compressor.

---

3. The compressor is started and the main reservoir is pumped up to 1500 psi.

---

4. The launcher generator is started and the launcher cable and control box are hooked up.

---

5. Snubber pressure is set.

---

6. If a blivit launch is to be made, the blivit is set in the launch cradle, the main launch pressure is set to the desired value, and the blivit is fired with a countdown of five.

---

7. If a blivit launch is not practical, the launch cradle should be pushed by hand to the extreme front end of the rail, and returned to the back end using the pneumatic return controls on the control box. This procedure cleans the rail and piston and prepares the system for an actual launch.

---

8. If a blivit launch was made, the reservoir must be pumped back up to 1500 psi and snubber pressure set.

---

NOTE: Launcher may need to be repositioned prior to launch due to wind direction.

<u>TIME</u>	<u>EVENT</u>	<u>PERSONNEL</u>	<u>CHECK</u>
T-6 Hrs	C. <u>Ground Control Station Preparation</u>	Dean Miller	

The ground control van must be parked within 100 feet of the recovery runway and launcher so the pilot has the best possible view of the aircraft for launch and landing. The antenna trailer should be located another 80 feet farther away from the runway in an unobstructed area. For safety reasons, the ground control station will be stationed no nearer than 40 feet from the launcher (not up or down wind). The system is prepared as follows:

1. Remove protective tarpaulin from antenna trailer. 

---
2. Connect all cables between van and antenna trailer. 

---
3. Start generators on van and trailer. 

---
4. Activate the ground control station and check functions of transmitters, recorders, etc. 

---
5. Activate and check pilot intercom network. 

---
6. Check manual operation of tracking antenna. 

---

<u>TIME</u>	<u>EVENT</u>	<u>PERSONNEL</u>	<u>CHECK</u>
T-5 Hrs	D. <u>Prelight</u>	(Bonnema, Cline, * Lowe, Miller)	

1. After the vehicle has been assembled, control van activated, and the launcher prepared, the vehicle is lifted onto the launch cradle by five

people; two under each wing and one on the tail. After seating the vehicle in the cradle, the vehicle is safety wired in place. This wire breaks at the instant of launch, but holds engine thrust loads prior to launch. Preflight checks are performed as follows:

2. Activate vehicle uplink and check remote operation of aileron, elevator, rudder, and speed controller.

3. Check kill switch operation.

4. Adjust trims of all four control functions.

5. Activate wing leveler, and then slightly yaw and roll aircraft to verify wing leveler function. Aileron control surface deflections should be observed when the wing leveler is active and the aircraft is disturbed in yaw or roll.

6. Check failsafe function by shutting off transmitters in control van. Within one second of shutdown, the controls on the vehicle should enter this condition - ailerons: neutral, rudder: 15 degrees trailing edge right, elevator: 4 degrees trailing edge up, speed control: full idle. When transmitters are restored, the vehicle should return to normal operation within one second.

7. Lead acid battery runup of motor and check out all vehicle systems once again.

8. Turn off all systems.

<u>TIME</u>	<u>EVENT</u>	<u>PERSONNEL</u>	<u>CHECK</u>
T-4 Hrs	E. <u>Battery Preparation</u>	(Garoutte, Michener, * Marsh, Vukson)	

Battery preparation includes filler tube hook-up, nose shell installation and battery tests. These tests will be performed exclusively by Honeywell personnel with assistance by Dick Marsh. Position flatbed truck next to launcher before beginning this section.

1. Check all single cells for shorting and check pos/neg master polarities connected to the pos/neg terminals at the Elcon connector.

2. Install battery on vehicle, connect 2 thermacouples to top rack cells front, bottom rack front, scan single cell voltages and fit nose cone. Insert lanyard C shown in Functional Activation Diagram (FAD).

3. Set up the activation system shown in FAD. \_\_\_\_\_
4. Close all valves, 1 through 10, when assembling system. \_\_\_\_\_
5. String lanyard C for remote pull activation as required. C requires pull or rope attachment. \_\_\_\_\_
6. Screw pull pin in hole on nose shell for fill mechanism release. \_\_\_\_\_
7. Start vacuum pump. \_\_\_\_\_
8. Open valves 4, 5, 6, and 7 to evacuate system (1, 2, 3, 8, 9, and 10 remain closed). The hydraulic clamp should be open.

NOTE: This procedure required approximately one hour. Vacuum should reach 500 microns or less at the pump head and 1200 microns or less at the activator prior to filling and/or proceeding as follows:

a. Close valve 6 and monitor the vacuum decay rate in the activation system to determine if pressure goes above 500 microns within 10 minutes. If above conditions are not met, consultation between Marsh and Garoutte will be held to define further alternatives.

b. Open valve 6 after delay rate is check is ok. \_\_\_\_\_

c. Turn on servo power, ground power and cooling fans. \_\_\_\_\_

NOTE: Outside temperature must be below 75<sup>o</sup>F or battery set up and electrolyte must be refrigerated.

9. Perform telemetry checkout using ground power (\*Miller, Lowe). \_\_\_\_\_
10. Set launcher pressure (Cline). \_\_\_\_\_
11. Verify launch window (Thompson). \_\_\_\_\_
- 11a. Check winds. \_\_\_\_\_

12. Mix the electrolyte and catalyst only after verifying steps 8 thru 11  
(Garoutte, Michener, \*Marsh). \_\_\_\_\_

13. Remove diptube from pre-mixed electrolyte container. \_\_\_\_\_

X 1/4" Swaglock valves  
appropriately numbered

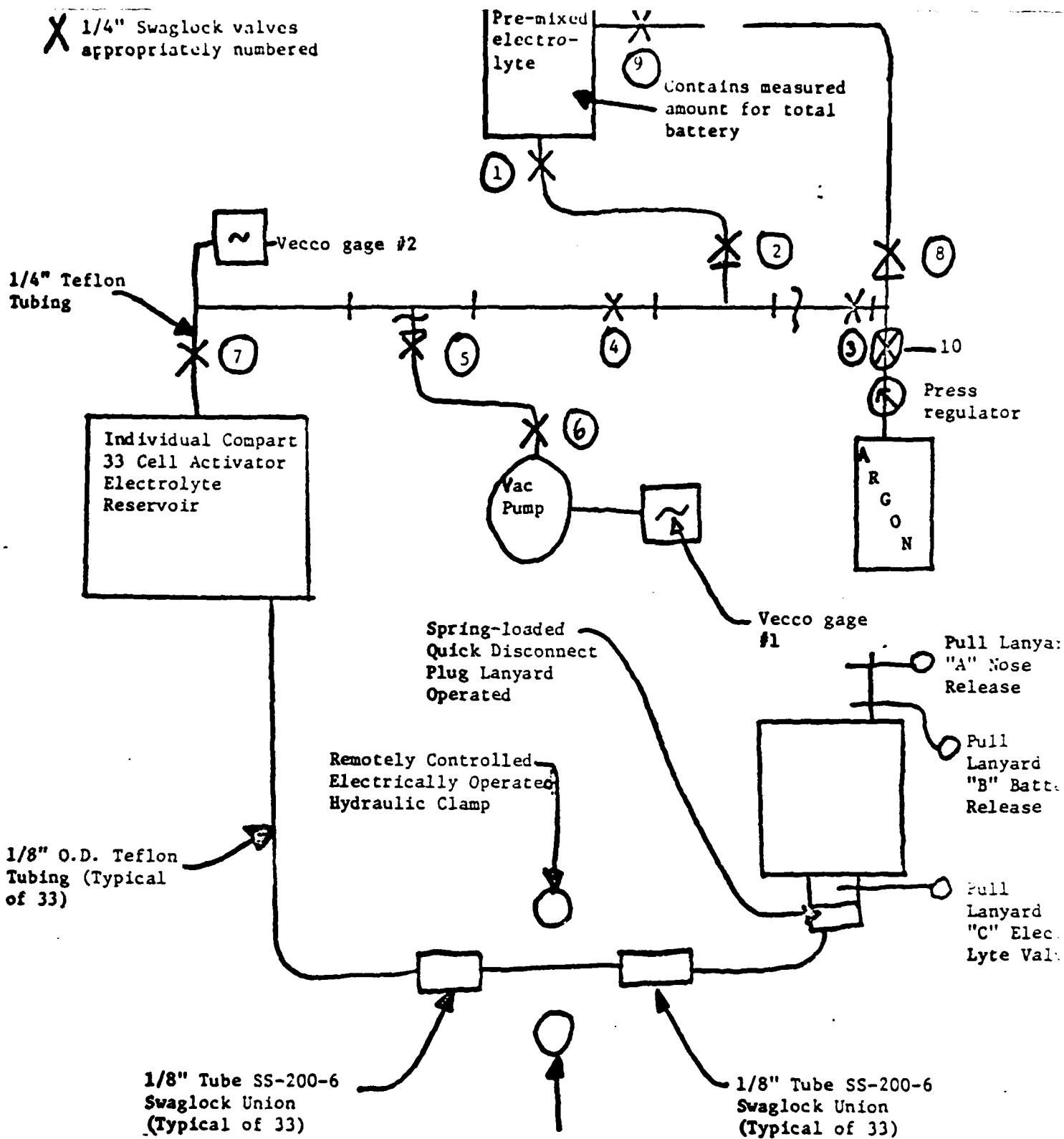

Functional Activation Diagram

NOTE: Test process after step 13 is pretty much irreversible.

14. Add a preweight of catalyst through a funnel to the container and shake the container well.

---

15. Close pre-mixed electrolyte container by reinstalling the diptube and reinstall the bottle to the set-up.

---

16. Close remotely controlled electrically operated hydraulic clamp and valves 5 and 6 to the vacuum pump.

---

17. Open valve 1 and 2 allowing electrolyte transfer to the activator to occur. A small amount of argon pressure (less than 25 PSI) may be required to transfer by opening valves 8, 9 and 10. Start with 5-10 PSIG and increase gradually as required.

---

NOTE: Shut off power to vacuum pump. Turn on cooling fan.

18. After transfer, close valves 1, 2, 8, and 9. Valves 5 and 6 remain closed.

---

18a. Pull ground power cable. Turn on internal power and motor switch.

---

NOTE: Battery is now ready for activation.

19. Telemetry checkout required using vehicle internal power (\*Miller and Lowe).

---

20. Check launcher pressure (Cline).

---

21. Adjust argon pressure to 20 PSI (Garoutte and \*Marsh).

---

22. Open valve 3 to apply 20 PSI of argon above the electrolyte.

---

23. Evacuate all unnecessary personnel from the launch area (PA) (Smith).

---

24. Prepare to remotely open the hydraulic clamp (Garoutte, \*Marsh).

---

25. Marsh must move to ground control van to receive signal from Garoutte that hydraulic clamp is open.

26. Marsh signals Garoutte that instrumentation is ready for activation.

26a. Ensure EOD equipment is running.

b. Check wind direction - wind into telemetry van (no go).

NOTE: This is the last step that a hold can be incurred.

27. At agreed upon time, electrically open remotely controlled hydraulic clamp.

28. Garoutte signals to Marsh that electrolyte activation has started.

29. Marsh signals to Miller on the same and to start OCV observations.

NOTE: Battery activation should take less than two minutes. Visual indication can be seen via observing fill lines into the bottom of RPV nose cone.

30. After activation, close electrically remote hydraulic clamp.

31. Verify proper operation of open circuit voltage scanner (Luke).

32. Alert for T = 0.

33. Pull lanyard "C" to disconnect electrolyte to fill system (Garoutte, \*Marsh).

34. Signal Miller and Luke that T = 0.

35. Remove truck with equipment to safe area.

NOTE: OCV data should be taken for two minutes.

36. Pull safety valve pin on launcher and signal pilot the pin is out (Marsh).

37. Luke signals to Miller and Lowe to start a light load discharge for eight minutes ( 500 RPM).

NOTE: Terminate test if any conditions under Section VIII: Emergency procedures exists.

<u>TIME</u>	<u>EVENT</u>	<u>PERSONNEL</u>	<u>CHECK</u>
	F. <u>Launch Procedure</u>	(Cline, Lowe, *Miller)	
	1. Review control van data to assure that battery and control/data system are working properly (*Miller, Luke).		
	2. Run motor to max power and read out RPM (approximately 5 seconds) (Lowe, *Miller).		
	a. Verify motor input readout is functioning properly.		
	3. Reduce motor RPM to idle ( 200 watts, 60 sec).		
	<u>NOTE:</u> Steps 2 and 3 can be repeated (Max T = 2 min).		
	4. Start 5 second countdown and go to full power (*Cline, Lowe).		
	5. FT = 0 Launch.		

<u>TIME</u>	<u>EVENT</u>	<u>PERSONNEL</u>	<u>CHECK</u>
FT + 0	G. <u>In-flight</u>	Pilot	
	These procedures pertain to the pilot.		
	1. If power is inadequate to sustain flight after launch, the vehicle should be landed straight ahead.		
	2. If power is adequate, the vehicle should climbt straight ahead at the maximum climb rate ( 600ft/min), and then turn 90 degrees left or right when it reaches a distance of 2500 feet from the pilot.		
	3. A circular flight path around the pilot at a radius of 2500 feet should be established.		
	4. Climb to the target altitude at reduced climb rate ( 500ft/min) should be accomplished as soon as possible after turning onto the circular track to cruise altitude (1200-1500 ft AGL).		

---

5. Flight will continue on the circular flight path at the planned minimum cruise velocity. All data read outs will be monitored for satisfactory operation. Battery energy consumption will be monitored to predict battery end of life.

---

6. If the flight proceeds normally, the vehicle will land on the recovery runway when 90 percent of the battery capacity is expended.

---

## VII BATTERY DISPOSAL PROCEDURES

### EOD PERSONNEL

A. Prepare disposal charge (site to be determined on day of the test) by constructing a four walled fixture with the inside width of 12", length of 30" and a height of 14" utilizing C-4 explosive. Prepare electric firing line (2000 ft) but do not connect blasting cap into main charge.

---

B. Approximately 15 minutes before termination of flight, connect blasting cap into main charge.

---

C. After the RPV has landed, position the wedge near the nose faring of the RPV. Relocate the dud retriever on the right side of the RPV and shut off the toggle switch located on the forward top center line of the airframe.

---

D. Relocate dud retriever in front of the RPV and pull the lanyard to disconnect nose faring. Move dud retriever to remove faring from the area of the RPV. Recover and insert wedge under the battery.

---

E. Relocate the dud retriever on the left side of the RPV and remove pin that is securing the battery to the airframe.

---

F. Relocate dud retriever in front of RPV and remove wedge (this will allow the front of the battery to be lowered) to the ground.

---

G. Position the arm and remove the battery from the airframe.

---

H. Transport battery to prepared disposal charge and lower battery into charge.

---

I. Remove dud retriever from disposal site and detonate disposal charge.

---

J. Disposal of the battery due to an unexpected failure will be decided upon by the senior EOD person, TTD, Honeywell representative, and safety representative at the site.

---

#### VIII EMERGENCY PROCEDURES

These procedures will only be implemented if abnormal conditions exist which could result in rupture of the Lithium Thionyl Chloride battery and not covered by the detailed procedures above. These procedures will only be implemented by the TTD. When implemented, all nonessential personnel will evacuate the area by preplanned procedures. These people will report back to main base Officer's Club until contacted by TTD. The evaluation team remaining behind at the test site will have available breathing apparatus. The evaluation team will be designated prior to the Flight Readiness Review.

##### A. Prior to Launch.

If after activation battery power sags or the battery temperature rises appreciably while on the launcher, the vehicle will be ejected and landed downwind if possible.

(1) If battery cells have ruptured, the EOD team will wait until all burning or explosive actions have been completed prior to retrieving the battery for final destruction.

(2) If battery cells have not ruptured, the EOD team will proceed to remove battery for destruction.

##### B. Inflight

(1) If power sages prematurely in flight, the vehicle will be landed normally. The same procedures will apply as VIII A. above.

(2) If a catastrophic battery failure such as an explosion occurs in flight, there are two possibilities:

a. First, if flight control is maintained, the vehicle will be guided to a safe area and impacted unless a skid landing is possible.

b. Secondly, if positive flight control is lost, uplink transmitter will be shut off which will result in the vehicle entering its failsafe mode. Descent in failsafe mode is very rapid, but impact point is not controllable.

c. If the control system fails in flight, but the propulsion system operates normally, the airplane can be landed if the failure is partial and adequate control for landing is still available. If control loss is total or partial but inadequate to land, failsafe mode can be commanded by turning off uplink transmitter.

C. After Flight:

EOD team will proceed with battery removal and destruction unless there is a sign of fire.

LIMED  
— 8