

AD A137259

12

ADF 300501

TECHNICAL REPORT ARBRL-TR-02537

REFLECTED OVERPRESSURE IMPULSE ON A
FINITE STRUCTURE

Charles N. Kingery
George A. Coulter

DTIC
SELECTED
JAN 24 1984
A

December 1983



US ARMY ARMAMENT RESEARCH AND DEVELOPMENT CENTER
BALLISTIC RESEARCH LABORATORY
 ABERDEEN PROVING GROUND, MARYLAND

Approved for public release; distribution unlimited.

DTIC FILE COPY

84 01 23 011

Destroy this report when it is no longer needed.
Do not return it to the originator.

Additional copies of this report may be obtained
from the National Technical Information Service,
U. S. Department of Commerce, Springfield, Virginia
22161.

The findings in this report are not to be construed as
an official Department of the Army position, unless
so designated by other authorized documents.

*The use of trade names or manufacturers' names in this report
does not constitute endorsement of any commercial product.*

UNCLASSIFIED

SECURITY CLASSIFICATION OF THIS PAGE (When Data Entered)

REPORT DOCUMENTATION PAGE		READ INSTRUCTIONS BEFORE COMPLETING FORM
1. REPORT NUMBER	2. GOVT ACCESSION NO.	3. RECIPIENT'S CATALOG NUMBER
TECHNICAL REPORT ARBRL-TR-02537	AD-A137 259	
4. TITLE (and Subtitle)	5. TYPE OF REPORT & PERIOD COVERED	
REFLECTED OVERPRESSURE IMPULSE ON A FINITE STRUCTURE	Final	
	6. PERFORMING ORG. REPORT NUMBER	
7. AUTHOR(s)	8. CONTRACT OR GRANT NUMBER(s)	
Charles N. Kingery George A. Coulter	CE-BRL-82-1	
9. PERFORMING ORGANIZATION NAME AND ADDRESS	10. PROGRAM ELEMENT, PROJECT, TASK AREA & WORK UNIT NUMBERS	
US Army Ballistic Research Laboratory, ARDC ATTN: DRSMC-BLT (A) Aberdeen Proving Ground, MD 21005	4A66 5805 M857	
11. CONTROLLING OFFICE NAME AND ADDRESS	12. REPORT DATE	
US Army AMCCOM, ARDC Ballistic Research Laboratory, ATTN: DRSMC-BLA-S (A) Aberdeen Proving Ground, MD 21005	December 1983	
14. MONITORING AGENCY NAME & ADDRESS (if different from Controlling Office)	13. NUMBER OF PAGES	
	58	
	18. SECURITY CLASS. (of this report)	
	UNCLASSIFIED	
	18a. DECLASSIFICATION/DOWNGRADING SCHEDULE	
16. DISTRIBUTION STATEMENT (of this Report)		
Approved for public release; distribution unlimited.		
17. DISTRIBUTION STATEMENT (of the abstract entered in Block 20, if different from Report)		
18. SUPPLEMENTARY NOTES		
This work was performed for and funded by the Department of Defense Explosives Safety Board.		
19. KEY WORDS (Continue on reverse side if necessary and identify by block number)		
Airblast	Reflective Pressure	
Overpressure	Reflected Impulse	
Impulse	Angle of Incidence	
Structure Loading		
20. ABSTRACT (Continue on reverse side if necessary and identify by block number)		
<p>The effect of angle of incidence of the shock front on reflected impulse loading on a finite structure is presented in this report. Impulse reflection factors have been developed for angles of incidence from zero to ninety degrees. Reflected impulse on a finite structure is much less than reflected impulse on an infinite plane because of the unloading due to rarefaction waves propagation from the sides of the structure which lowers the reflected overpressure.</p>		

DD FORM 1 JAN 73 1473 EDITION OF 1 NOV 68 IS OBSOLETE

UNCLASSIFIED
SECURITY CLASSIFICATION OF THIS PAGE (When Data Entered)

LIST OF ILLUSTRATIONS

Figure	Page
1. The 1/50th Scale Steel Structure Model	10
2. Concrete Mount with Anchor Bolt	10
3. Exploded View of the Model, Mount, and Pressure Transducers	12
4. Instrumentation Block Diagram	13
5. Test Layout	14
6. Photograph of Models 2, 1, 4, and 5 with 0 and 90 Degree Orientation	16
7. Reflected Pressure versus Incident Overpressure for a Shock Wave Undergoing Regular Reflection on a Rising Slope	20
8. Reflected Pressure versus Incident Overpressure for Shock Waves Undergoing Mach Reflection on a Rising Slope	21
9. Reflection Factors versus Angle of Incidence for Selected Incident Overpressures	22
10. Peak Incident Overpressure versus Scaled Distance for a 1 kg Hemispherical Surface Burst	26
11. Incident Scaled Impulse versus Scaled Distance for a 1 kg Hemispherical Surface Burst	27
12. Peak Reflected Pressure versus Angle of Incidence for Stations 1 through 8	28
13. Scaled Reflected Impulse versus Angle of Incidence for Stations 1 through 8	29
14. Reflected Pressure Ratios (P_r/P_g) versus Angle of Incidence for P_g from 346 kPa to 67.4 kPa	39
15. Reflected Pressure Ratios (P_r/P_g) versus Angle of Incidence for P_g from 40.8 kPa to 6.2 kPa	40
16. Reflected Impulse Ratios (I_r/I_g) versus Angle of Incidence ...	41
17. Reflected Pressure versus Incident Pressure in the Regular Reflection Region	42

LIST OF ILLUSTRATIONS (CONT)

Figure		Page
18.	Reflected Pressure (P_r) versus Incident Pressure (P_i) in the Mach Reflection Region as a Function of Angle of Incidence	43
19.	Scaled Reflected Impulse (I_r) versus Scaled Incident Impulse (I_i) in the Regular Reflection Region	45
20.	Scaled Reflected Impulse (I_r) versus Scaled Incident Impulse (I_i) in the Mach Reflection Region as a Function of Angle of Incidence	46

LIST OF TABLES

Table	Page
1. Predicted Peak Pressures and Impulses for Test 1	17
2. Model Orientation, Tests 1-12	18
3. Model Orientation, Tests 13-15	18
4. Incident Overpressure and Impulse at Free-Field Stations	24
5. Reflected Pressure and Impulse Ratios versus Angle of Incidence	30

I. INTRODUCTION

A. Background

During one of the meetings of the Blast Technology Subcommittee for the Revision of the Protective Structures Manual¹ it was pointed out that there was a data gap with regard to the effect of angle of incidence on reflected impulse impinging on finite structures. The effect of angle of incidence of the shock wave striking an infinite plane on peak reflected pressure and reflected impulse has been documented in many height of burst studies. The latest of these was conducted in Canada and reported in References 2 and 3. After a literature survey there appeared to be little information on the effect of angle of incidence on reflected impulse loading of isolated structures.

B. Objective

The objective of this study is to determine experimentally the effect of angle of incidence of the shock front on the reflected impulse loading on an isolated structure. The experiment was conducted with 1/50 scaled nonresponding models of a single structure.

II. TEST PROCEDURES

This section will describe the procedure followed in conducting an experimental program to meet the stated objective.

A. Design of Model

The model was designed to represent a structure 15.24 metres wide by 15.24 metres long by 22.86 metres high (50 ft x 50 ft x 75 ft). A 1/50th scale produced a model 0.305 m x 0.305 m x 0.457 m (1 ft x 1 ft x 1.5 ft). The model was constructed of a 2.54 cm thick steel plate. A sketch of the model is presented in Figure 1. The four upright walls were welded together with the top bolted on to allow access to the pressure gages. A reinforced concrete mount with an anchor bolt imbedded (as shown in Figure 2) was used to secure the model. The pressure transducers were then

¹ Department of the Army, the Navy, and the Air Force, "Structures to Resist the Effects of Accidental Explosions," June 1969, TMS-1300, NAVFAC P-397, AFM 88-22.

² R.E. Reisler, B. Pettit and L. Kennedy, "Air Blast Data from Height of Burst Studies in Canada, Vol I: HOB 5.4 to 77.9 Feet," BRL Report No. 1950, December 1976 (AD B016344L).

³ R.E. Reisler, B. Pettit and L. Kennedy, "Air Blast Data from Height of Burst Studies in Canada, Vol. II, HOB 4.5 to 144.5 Feet BRL Report No. 1990, May 1977.

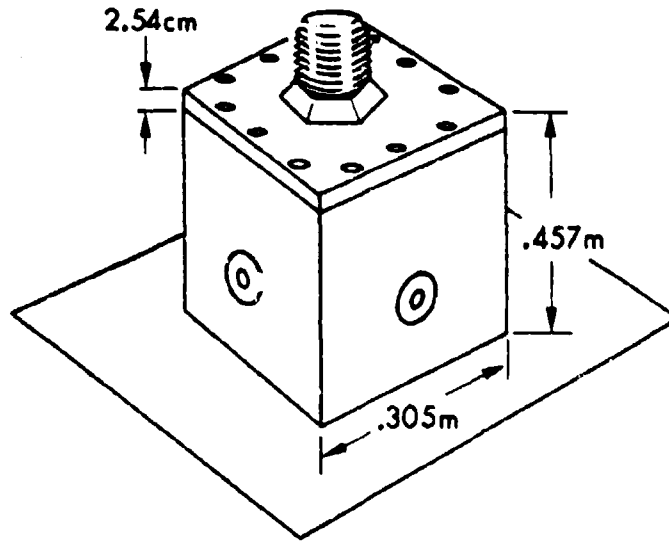

Figure 1. The 1/50th Scale Steel Structure Model.

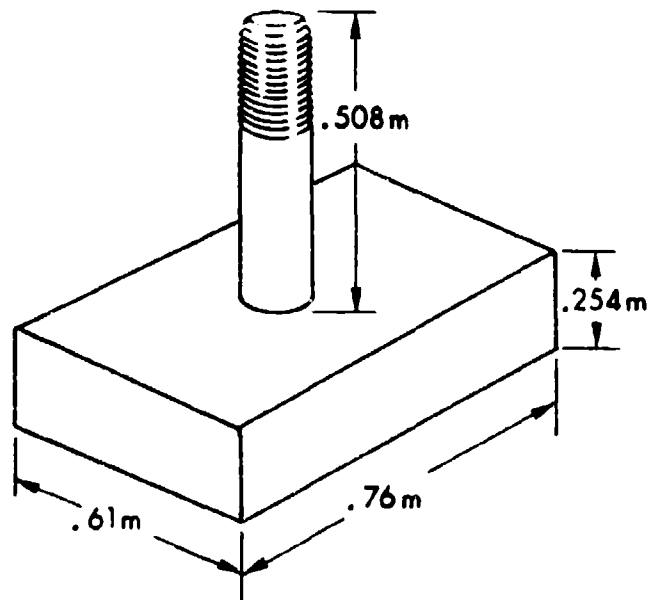

Figure 2. Concrete Mount with Anchor Bolt.

installed and the top plate was bolted in place. An exploded view of the model, mount, and pressure transducers is shown in Figure 3. The model was held in place by tightening the large nut down against the top plate. By loosening the nut, the model orientation could be changed for each test and then retightened. A total of eight models was constructed. The pressure transducers were placed on the center line of a front and side wall at a height of 0.152 m. The model was rotated to change the angle of incidence of the shock front with the model walls.

B. Test Charges

The test charges were cast Pentolite (50 PETN, 50 TNT). The shape was hemispherical and the point of detonation was at the center of the flat side which was placed on the ground surface. The full size charge yield selected for simulation was 125000 kilograms. Therefore, a 1/50 scale model would require (according to cube root scaling) a one-kilogram charge. One-kilogram cast Pentolite charges were used on all of the fifteen tests conducted.

C. Test Instrumentation

The instrumentation for this test series consisted of pressure transducers, magnetic tape recorder/playback, and a data reduction system. A block diagram is shown in Figure 4.

1. Pressure Transducers. Piezoelectric pressure transducers were used for this series of tests. The PCB Electronics Inc., Models 112A22, 113A24, and 113A28, with quartz sensing elements and built-in source followers were used extensively.

2. Tape Recorder System. The tape recorder consisted of three basic units, the power supply and voltage calibrator, the amplifiers, and the FM recorder. The FM tape recorder was a Honeywell 7600 having a frequency response of 80 kHz. Once the signal was recorded on the magnetic tape it was played back and recorded on a Honeywell Visicorder. This oscillograph has 5 kHz frequency response and the overpressure versus time recorded at the individual stations can be read directly from the playback records for preliminary data analysis.

3. Data Reduction System. For the final data output, the tape signals were processed through an analog-to-digital converter, to a digital recorder-reproducer, and then to a computer. The computer (TEKTRONIX 4051) was programmed to apply the calibration values and present the data in the proper units for analysis. From the computer, the data is put on a digital tape from which the final form can be plotted or tabulated. The digital tape can be also stored for future analysis.

D. Test Layout

The test layout was planned to acquire the maximum amount of data for each test conducted. A total of eight peak overpressure levels was selected and therefore eight models were constructed. Twenty-one angles of incidence were selected with eleven bunched between 37.5 and 62.5 degrees in order to document the transition between regular reflection and Mach reflection. The test layout is shown in Figure 5. The peak overpressure

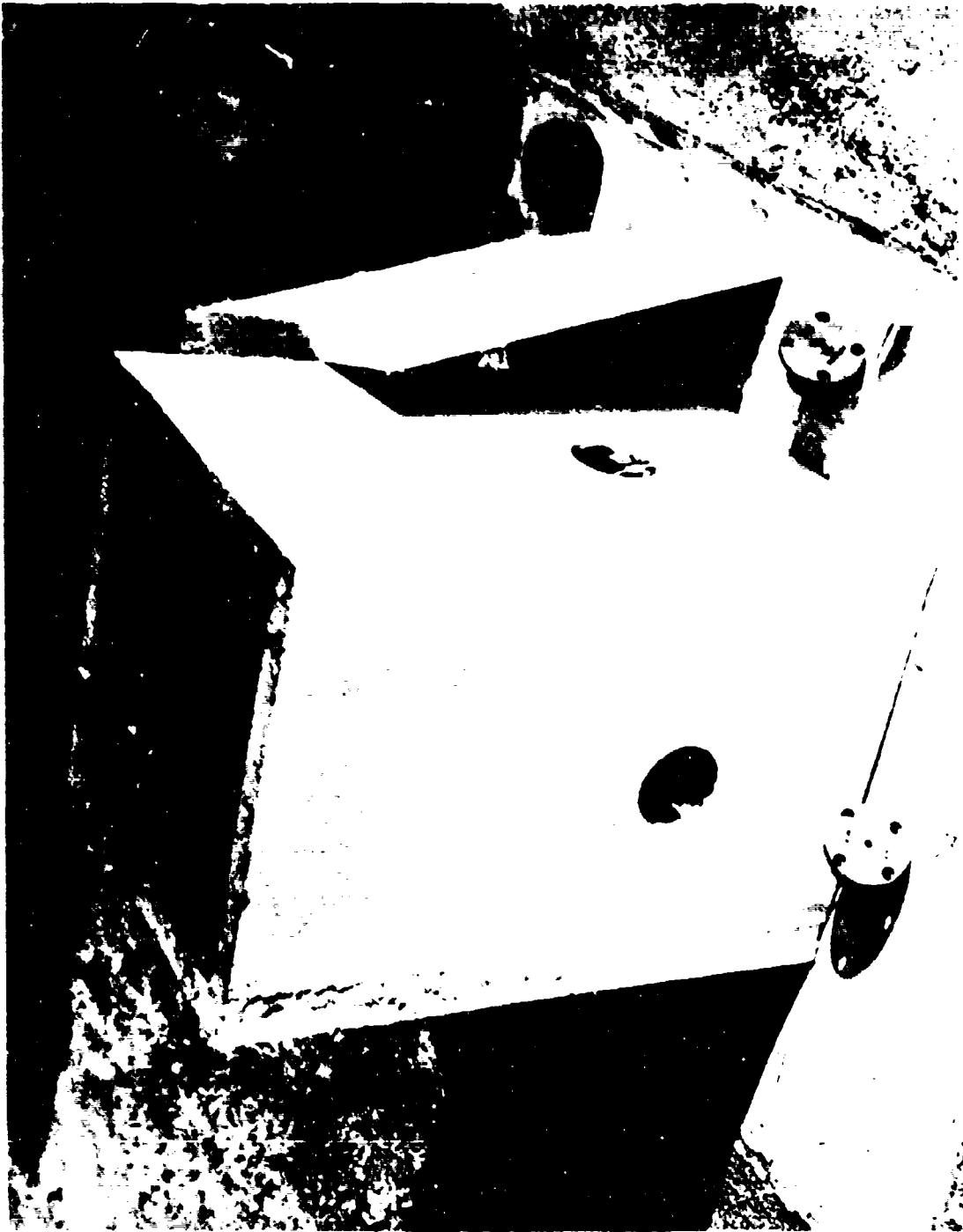

Figure 3. Exploded View of the Model, Mount, and Pressure Transducers.

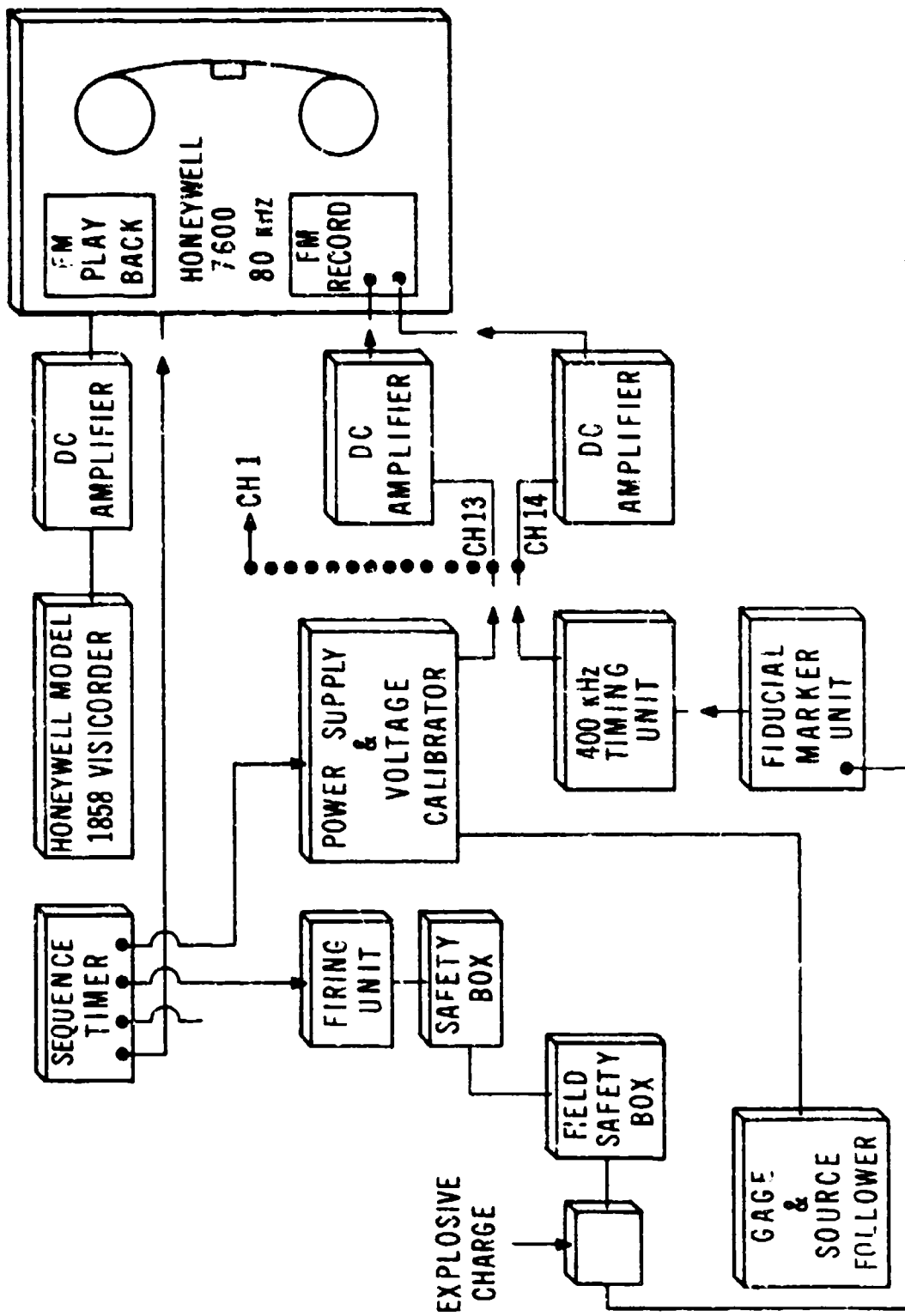
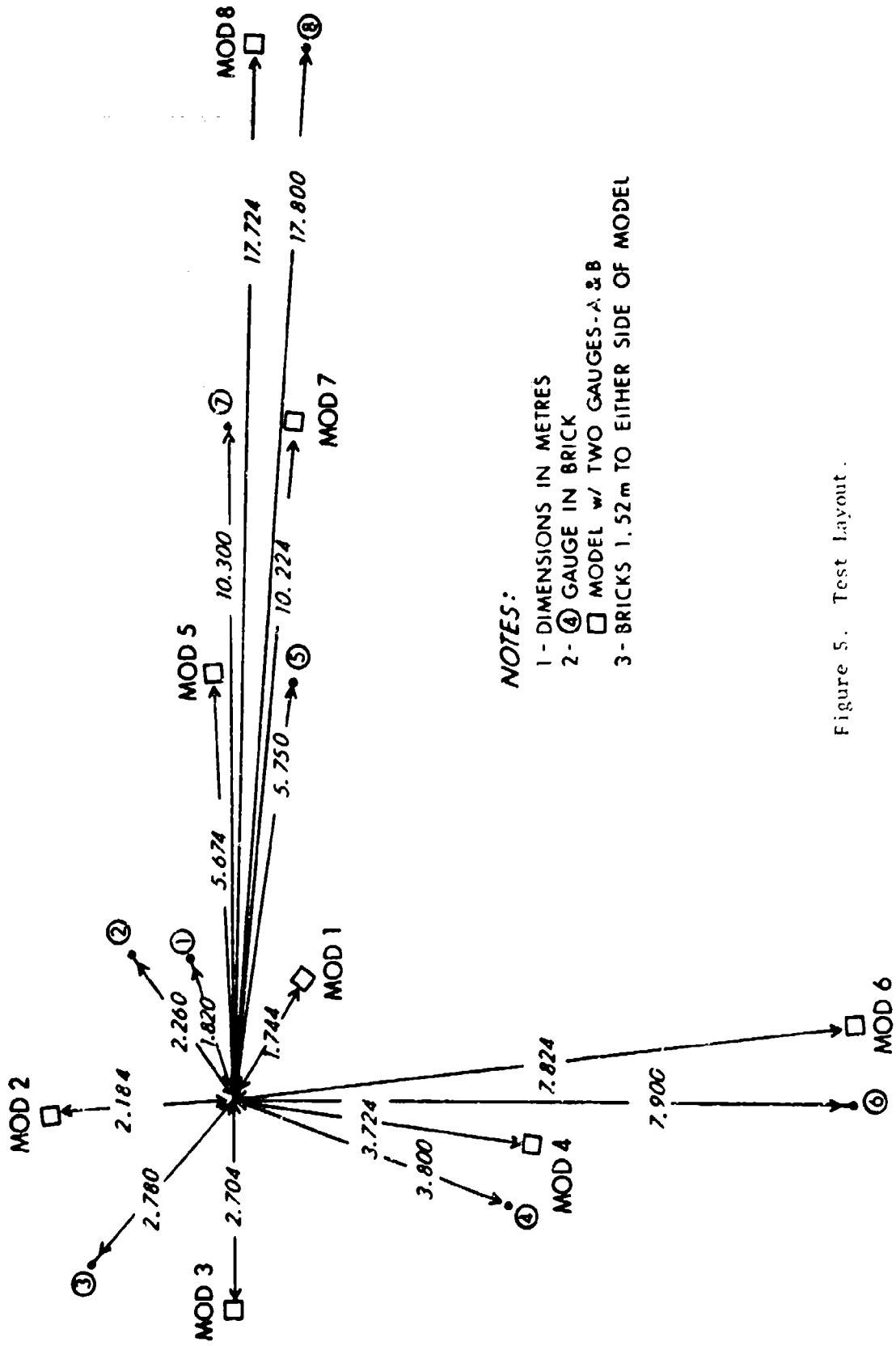

Figure 4. Instrumentation Block Diagram.



- NOTES:**
- 1 - DIMENSIONS IN METRES
 - 2 - ④ GAUGE IN BRICK
 - MODEL w/ TWO GAUGES - A & B
 - 3 - BRICKS 1.52m TO EITHER SIDE OF MODEL

Figure 5. Test layout.

range of interest for this project was from 345 kPa down to 6.89 kPa. The distances selected to meet the required pressure range were based on the standard TNT hemispherical surface burst curve.⁴ The free-field incident peak overpressure was measured near each structure to provide the input blast parameters. Nomenclature used to identify the gage locations at each station is as follows: Station 1 is the free-field gage, Station 1A is in the front of the model with orientation from 0 to 45 degrees, and Station B is in the side of the model with orientation from 90 to 45 degrees. On Test 1, Station A on all models was at an angle of 0 degrees or normal reflection while Station B on all models was at an angle of 90 degrees or a side-on measurement. The station locations, predicted peak overpressures, and impulses are listed in Table 1 for Test Number 1. The locations of the free-field stations remained the same on all 15 tests. The radial distances for the Stations A and B changed on each shot. A photograph showing Structures 2 (foreground), 1, 4, and 6 for 0 degree and 90 degree orientation with a 1 kg charge in place is presented in Figure 6.

E. Test Matrix

Eight model structures were placed at the distances shown in Table 1 to receive the predicted input pressure and impulse. After each test, each model was rotated the same number of degrees in order that the shock front would strike each set of structure walls at the same angles of incidence. The angle of incidence for Tests 1 - 12 is listed in Table 2. On Tests 13, 14, and 15 the structure models were exposed at different angles and at different pressure levels. These exposures are listed in Table 3.

F. Predictive Approach

There are many references in which the enhancement of peak overpressure as a function of angle of incidence is reported. One of the more complete treatments is given in Reference 5. Normal reflection or head-on reflection can be predicted for the range of incident overpressures of interest in these tests using the following equation:

$$P_r = 2 P_s \left(\frac{7 P_o + 4 P_s}{7 P_o + P_s} \right) \quad (1)$$

where P_o = Ambient atmospheric pressure,
 P_r = Normal reflected overpressure, and
 P_s = Side-on incident overpressure.

This is valid where the ratio of specific heat (γ) for air is a constant 1.4. The equation is good for predicting the reflected pressure when the models are in the 0-degree orientation, face-on.

⁴ C.N. Kingery, "Air Blast Parameters versus Distance for Hemispherical Surface Bursts," BRL Report 1344, September 1966 (AD 811673).

⁵ "Nuclear Weapons Blast Phenomena, Volume II, Blast Wave Interaction," DASA 1200-II, 1 December 1970 (Confidential RD).



Figure 6. Photograph of Models 2, 1, 4, and 6 with 0 and 90 Degree Orientation.

TABLE 1. PREDICTED PEAK PRESSURES AND IMPULSES FOR TEST 1

Station	Distance m	Pressure kPa	Impulse kPa-ms	Station	Distance m	Pressure kPa	Impulse kPa-ms
1	1.82	345	145	5	5.75	34.5	51
1A	1.74	1361	430	5A	5.67	78.7	110
1B	1.90	340	140	5B	5.83	33.9	50
2	2.26	207	120	6	7.90	20.7	39
2A	2.18	695	320	6A	7.82	44.9	80
2B	2.34	190	112	6B	7.98	20.8	38
3	2.78	138	98	7	10.30	13.8	30
3A	2.70	408	250	7A	10.22	29.1	59
3B	2.86	130	96	7B	10.38	13.7	30
4	3.30	68.9	74	8	17.80	6.89	18
4A	3.72	164	170	8A	17.72	14.7	32
4B	3.88	66.0	72	8B	17.88	6.89	18

TABLE 2. MODEL ORIENTATION, TESTS 1-12

Test No.	Angle of Incidence		Test No.	Angle of Incidence	
	A	B		A	B
1	0	90	7	37.5	52.5
2	10	80	8	40.5	49.5
3	16	74	9	42.5	47.5
4	21	69	10	43.5	46.5
5	27.5	62.5	11	45	45
6	34	56	12	0	90

* Tests 1 through 12 all models had same orientation

TABLE 3. MODEL ORIENTATION, TESTS 13-15

Station Test	1		2		3		4		5		6		7		8	
	A	B	A	B	A	B	A	B	A	B	A	B	A	B	A	B
13	34	56	34	56	40.5	49.5	40.5	49.5	37.5	52.5	37.5	52.5	37.5	52.5	37.5	52.5
14	37.5	52.5	40.5	49.5	46.5	43.5	42.5	47.5	40.5	49.5	43.5	46.5	0	90	40.5	49.5
15	43.5	46.5	16	74	16	74	21	69	16	74	45	45	21	69	16	74

** On Tests 13, 14, and 15 models were oriented for repeat exposure at selected angles and pressure levels.

A second source used for predicting the reflected pressure in the regular reflection region for different angles of incidence is Reference 6. This report is based on a theoretical treatment by J. Von Newman. It considers the shock wave reflecting on an infinite plane as in a height of burst study. The reference does not treat impulse.

A newer source, Reference 7, treats both the enhancement of pressure in the regular reflection on rising slopes as well as the enhancement in the Mach reflection region on rising slopes. The reflected pressure versus incident pressure undergoing regular reflection for various rising slopes (Figure 12 from Reference 7) is presented as Figure 7. The reflected pressure versus incident pressure undergoing Mach reflection for various rising slopes (Figure 5 from Reference 7) is presented as Figure 8.

A family of curves from Reference 8 showing the reflection factor or pressure ratio P_r/P_s for selected input pressures (P_s) versus angle of incidence are presented in Figure 9. They were used in predicting the reflected pressure, P_r , expected to load the model. These curves and the other predictive methods will be compared with the field measurements.

III. RESULTS

As mentioned in the introduction, the primary objective of this project is to determine the enhancement of overpressure impulse as a function of the angle of incidence of the shock front striking an isolated structure. Presented in Section F of Test Procedures are predictive approaches for determining the peak reflected pressure, but there is a lack of information on predicting the reflected impulse other than normal or head-on. Information that is available is from various height of burst studies, where the reflection process is on an infinite plane.

The results will be presented in the form of reflected pressure compared to side-on pressure or reflected pressure ratios (P_r/P_s). This comparison will also be done for impulse where ratios of I_r/I_s will be developed for angle of incidence and a variety of side-on or free-field impulses.

-
- 6 C.N. Kingery and R.F. Pannill, "Parametric Analysis of Regular Reflection of Air Blast," BRL Report 1249, June 1964 (AD 444997).
 - 7 Kenneth Kaplan, "Effects of Terrain on Blast Prediction Methods and Prediction," BRL Contract Report ARBRL-CR-00355, January 1978 (AD A051350).
 - 8 H. L. Brode, "Height of Burst Effects at High Overpressures," The Rand Corporation, RM-6301, DASA 2506, July 1970.

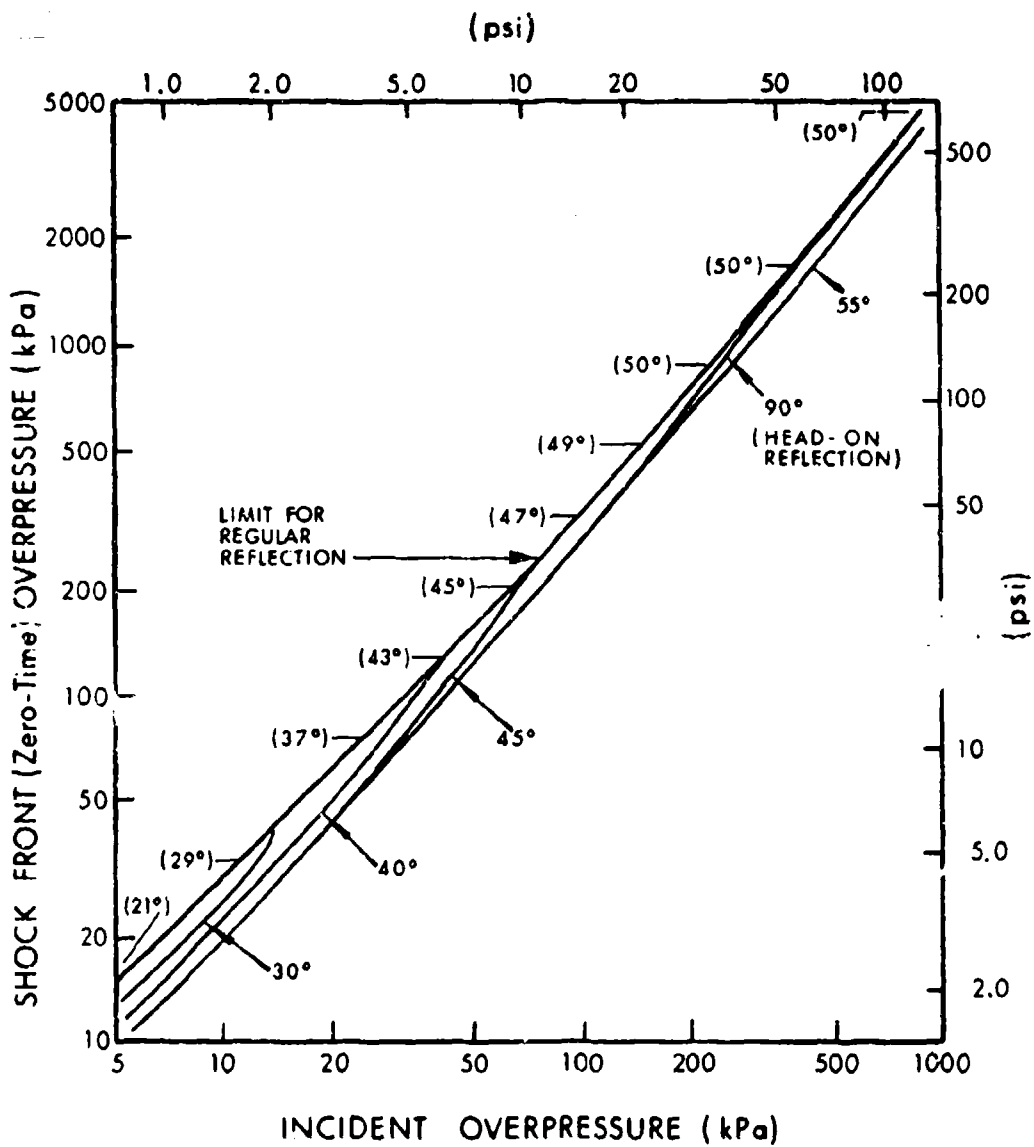

Figure 7. Reflected Pressure versus Incident Overpressure for a Shock Wave Undergoing Regular Reflection on a Rising Slope.

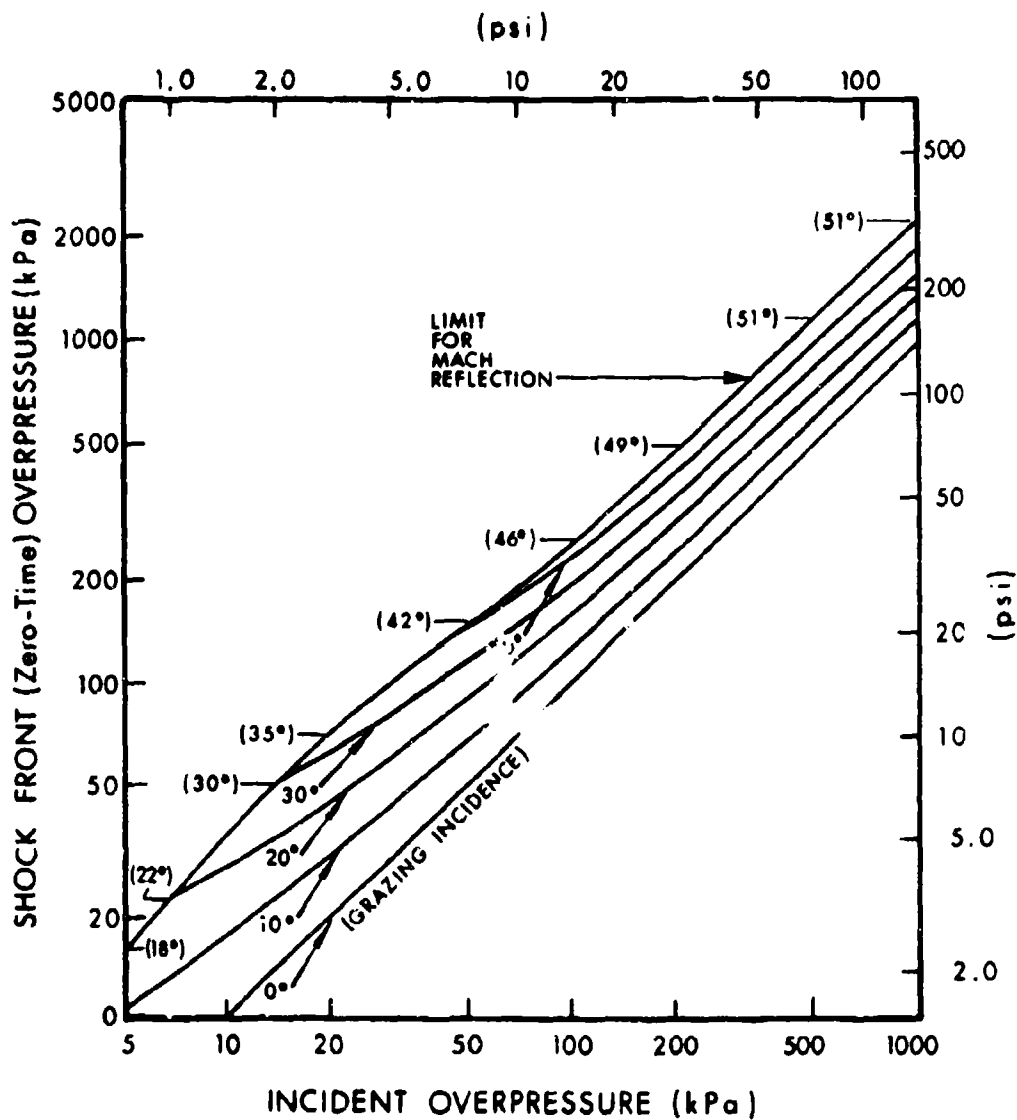

Figure 8. Reflected Pressure versus Incident Overpressure for Shock Waves Undergoing Mach Reflection on a Rising Slope.

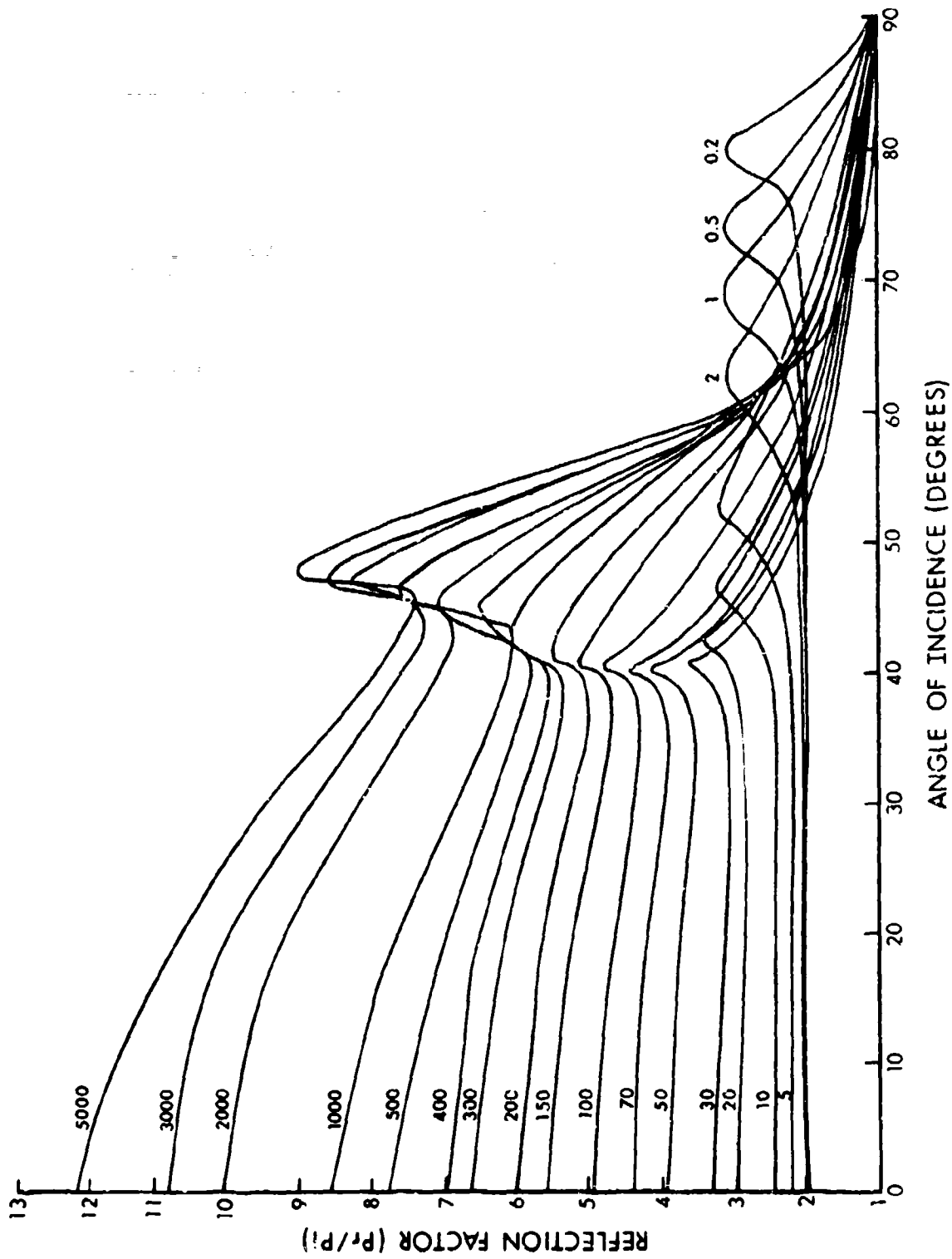

Figure 9. Reflection Factors versus Angle of Incidence for Selected Incident Overpressures.

A. Side-on Overpressure and Impulse Measurements

In order to determine the pressure reflection and impulse reflection ratios, the side-on or incident overpressures and impulses must be established. Eight pressure transducers were placed at the distances and locations shown in Figure 5 to record the incident overpressure versus time of the blast wave. Records were obtained on each test and the incident peak overpressure and incident overpressure impulses are listed in Table 4 for each station. An average value from the fifteen tests was used to plot a peak overpressure versus distance for a 1 kg hemispherical Pentolite surface burst. Over ninety percent of the values of both pressure and impulse fell within a ± 5 percent of the average value established at each station. The average peak incident overpressure (P_g) versus horizontal distances are plotted in Figure 10. The solid lines in Figures 10 and 11 were established from data presented in Reference 9. The average incident impulses (I_g) versus horizontal distances from Table 4 are plotted in Figure 11.

B. Reflected Peak Overpressure and Impulse versus Angle of Incidence

The reflected peak overpressure versus angle of incidence is a direct measurement made on the front and side wall of the model. The reflected impulse is obtained from the integration of the overpressure versus time recorded from Stations A and B located on the model.

The reflected pressure recorded on Stations 1A and 1B through 8A and 8B are plotted versus angle of incidence in Figure 12. The lines through the data points are visual fits and were used to establish the values of reflected pressure listed in Table 5.

The reflected impulses versus angle of incidence recorded at Stations 1A and 1B through 8A and 8B are plotted in Figure 13. The solid lines are visual fits of the data points and were used to determine the values of reflected impulse listed in Table 5.

C. Reflected Pressure and Impulse Ratios versus Angle of Incidence

Both the reflected pressure (P_r) and the reflected impulse (I_r) will be presented as a function of side-on pressure (P_g) and side-on impulse (I_g) in the form of ratios. That is, P_r/P_g and I_r/I_g will be presented versus angle of incidence.

The reflected pressure ratios P_r/P_g were calculated for each angle of incidence at each station and are listed in Table 5. It was noted in the Test Layout Section that Station A and Station B are located at different radial distances (ΔR) but this ΔR becomes less as the model is rotated and $\Delta R = 0$ at 45 degrees angle of incidence. In Table 5 the side-on

(Text continued on page 38)

⁹ Charles Kingery and George Coulter, "TNT Equivalency of Pentolite Hemispheres," ARBRL-TR-02456, December 1982 (AD A123340).

TABLE 4. INCIDENT OVERPRESSURE AND IMPULSE AT FREE-FIELD STATIONS

Test No.	Station 1		Station 2		Station 3		Station 4	
	Distance 1.82		Distance 2.26		Distance 2.78		Distance 3.80	
	P kPa	I kPa-ms	P kPa	I kPa-ms	P kPa	I kPa-ms	P kPa	I kPa-ms
1	327	110	169 ^A	103	121 ^A	85	66	68
2	335	116	227	105	134	88	70	70
3	332	117	220	100	135	87	69	69
4	303	113	209	103	127	88	66	66
5	308	116	196	103	129	86	74	70
6	307	113	195	102	127	84	71	67
7	340	117	206	104	129	84	68	68
8	302	112	201	102	135	84	69	67
9	N-1	N-1	208 ^A	99 ^A	131	86	66	69
10	N-1	N-1	172 ^A	106 ^A	138	83	68	66 ^A
11	321 ^A	115	208	100	135	87	86 ^A	286 ^A
12	380 ^A	116	190 ^A	105	139	89	68	63 ^A
13	315	121	215	99	139	85	71	67
14	324	114	200	108	131	91	72	69
15	292	120	212	104	140	91	69	71
AVG	317	115.4	208.6	102.6	133.5	86.5	69.1	68.2

^A Questionable value
N-1 - Not instrumented

TABLE 4. INCIDENT OVERPRESSURE AND IMPULSE AT FREE-FIELD STATIONS (CONT)

Test No.	Station 5		Station 6		Station 7		Station 8	
	Distance 5.75		Distance 7.90		Distance 10.3		Distance 17.8	
	P _s kPa	I _s kPa-ms	P _s kPa	I _s kPa-ms	P _s kPa	I _s kPa-ms	P _s kPa	I _s kPa-ms
1	39	45	25	34	13.9	24.4	6.1	15.0
2	40	43	26	35	14.5	25.3	5.9	15.1
3	42	45	26	36	14.1	25.3	6.2	15.1
4	41	49	25	35	13.1	25.3	7.4	15.4
5	41	46	25	35	13.7	25.6	5.8	14.8
6	39	45	25	35	13.6	25.1	5.7	14.9
7	39	47	25	35	13.9	25.6	6.7	15.2
8	39	47	25	35	13.5	25.9	5.2	15.5
9	40	47	24	34	14.4	24.4	N-1	N-1
10	38	46	25	35	13.6	24.8	N-1	N-1
11	40	47	24	36	14.2	25.5	5.9	15.2
12	41	49	25	35	14.6	26.1	6.1	15.8
13	39	47	25	36	14.0	26.0	5.9	15.5
14	41	47	24	36	14.7	26.7	6.9	16.2
15	41	47	24	36	14.9	25.9	6.7	16.1
AVG	40.0	46.5	24.9	35.2	14.1	25.4	6.27	15.4

N-1 - Not instrumented

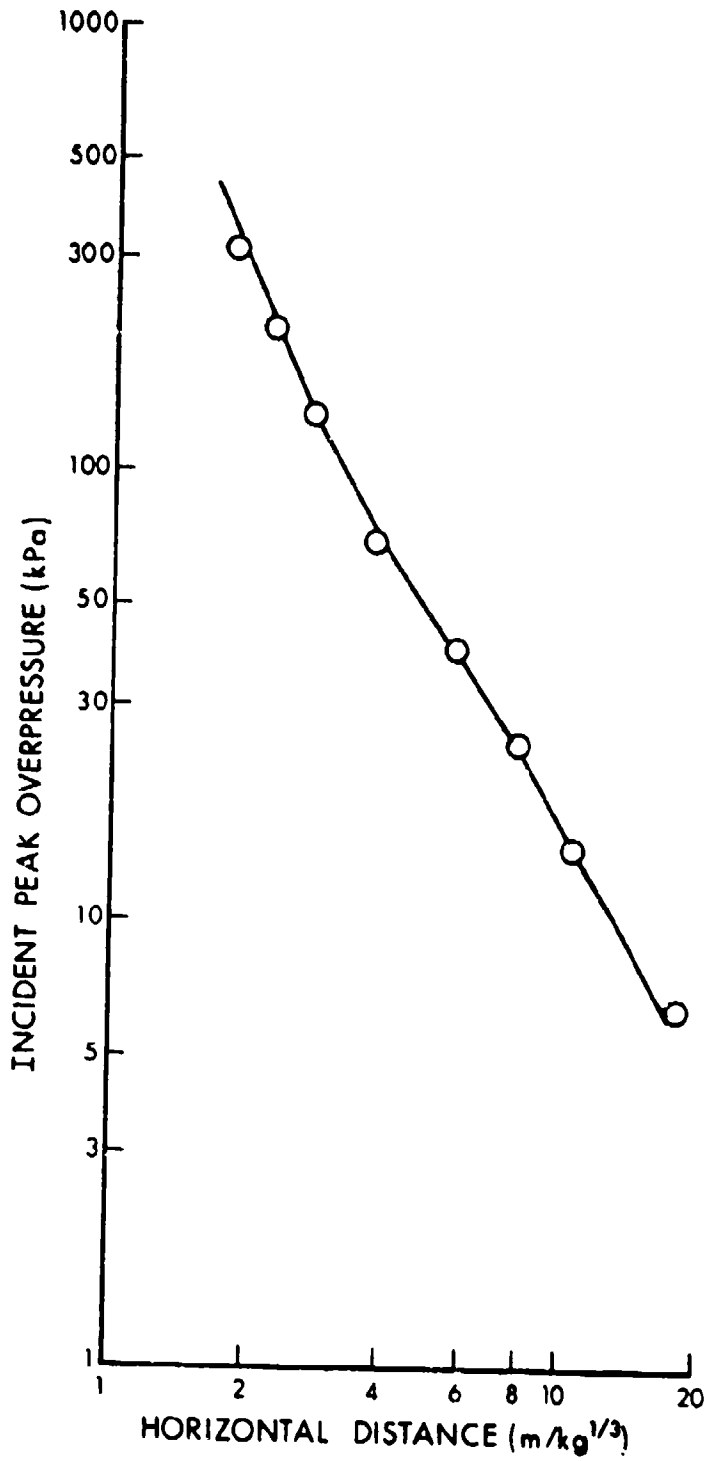

Figure 10. Peak Incident Overpressure versus Scaled Distance for a 1 kg Hemispherical Surface Burst.

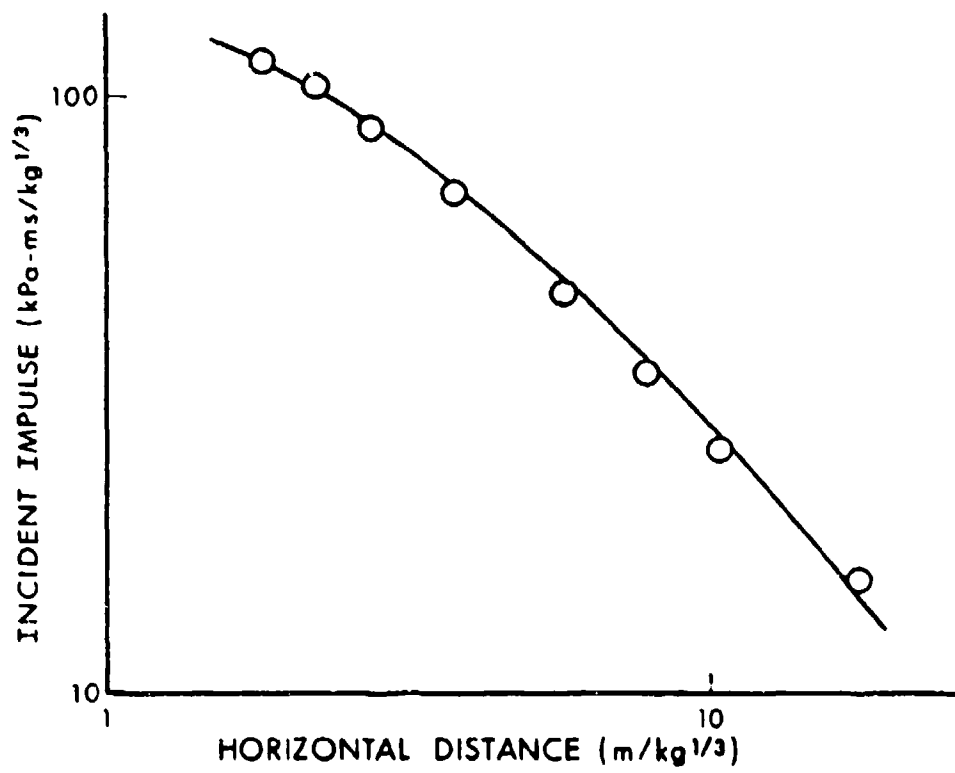

Figure 11. Incident Scaled Impulse versus Scaled Distance for a 1 kg Hemispherical Surface Burst.

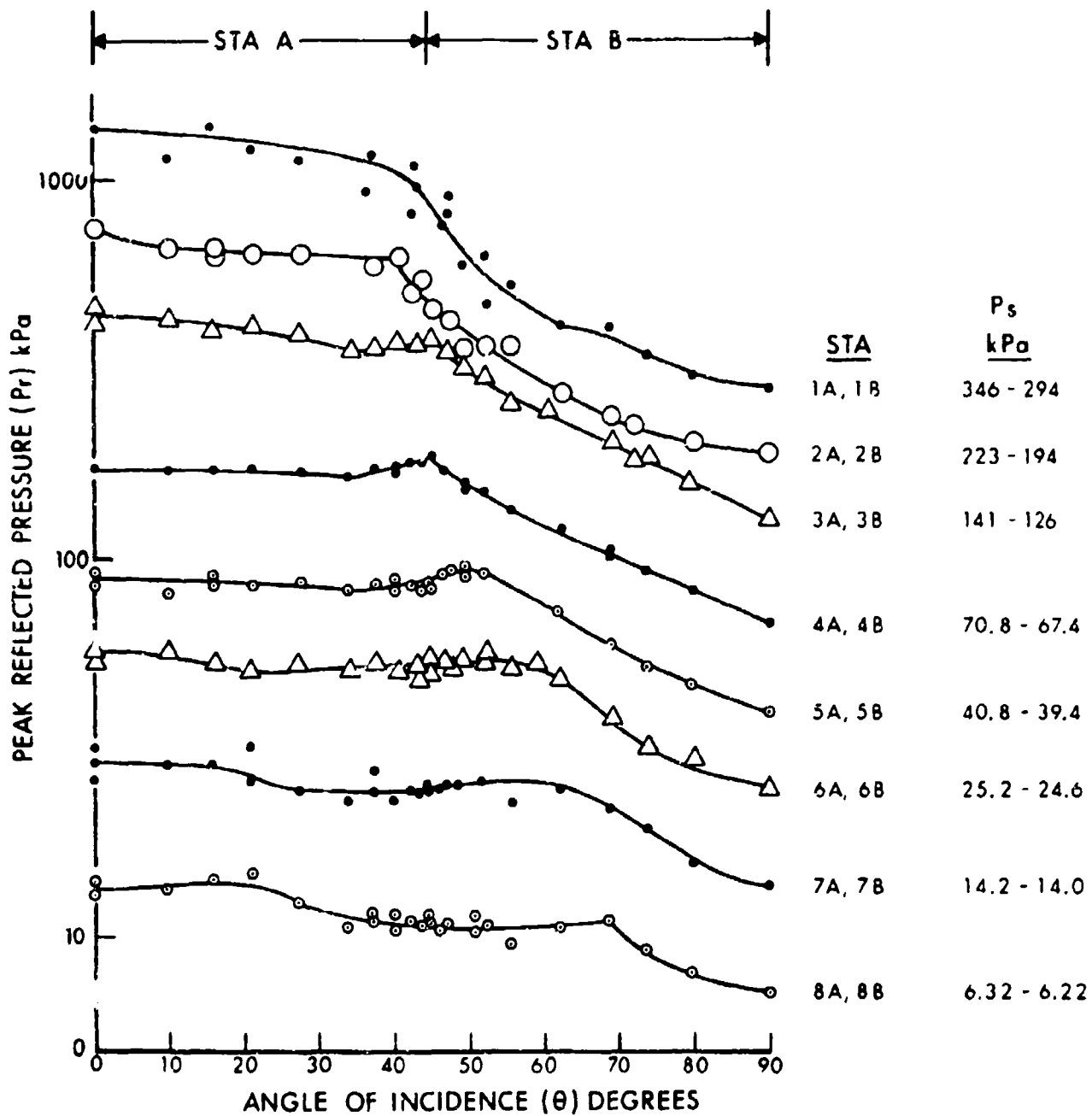

Figure 12. Peak Reflected Pressure versus Angle of Incidence for Stations 1 through 8.

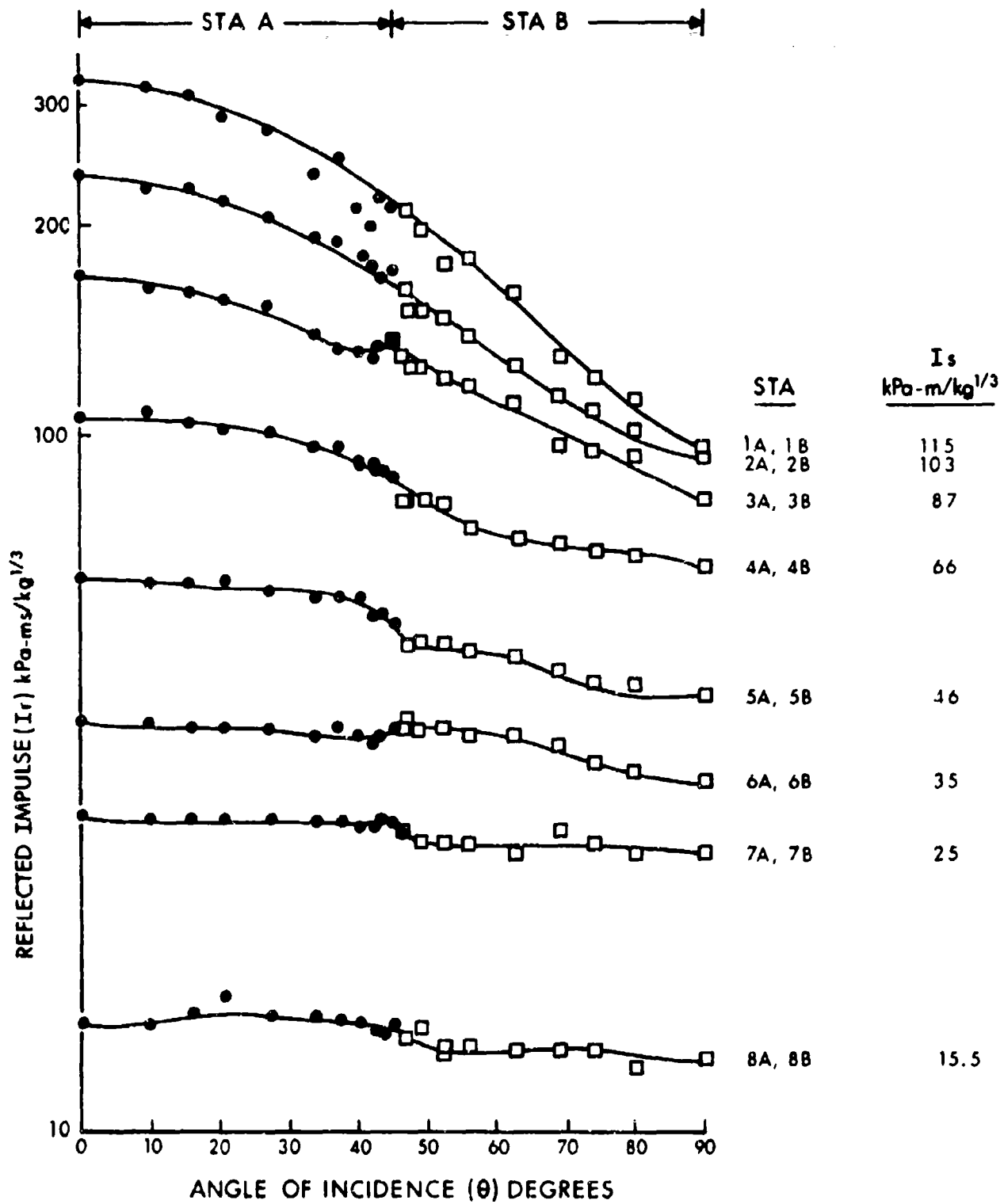

Figure 13. Scaled Reflected Impulse versus Angle of Incidence for Stations 1 through 8.

TABLE 5. REFLECTED PRESSURE AND IMPULSE RATIOS VERSUS ANGLE OF INCIDENCE

Station 1A, $P_s^* = 346$, $I_s^* = 118$				Station 1B, $P_s = 294$, $I_s = 113$					
Angle of Incidence degrees	REFL PRESS P_r kPa	PRESS REFL FACTOR P_r/P_s	REFL IMP I_r kPa-ms/kg ^{1/3}	IMP REFL FACTOR I_r/I_s	Angle of Incidence degrees	REFL PRESS P_r kPa	PRESS REFL FACTOR P_r/P_s	REFL IMP I_r kPa-ms/kg ^{1/3}	IMP REFL FACTOR I_r/I_s
0	1367	3.95	331	2.81	90	294	1.00	97	0.86
10	1310	3.81	325	2.75	80	310	1.06	114	1.01
16	1300	3.79	315	2.67	74	350	1.14	122	1.07
21	1280	3.74	291	2.47	69	390	1.25	130	1.14
27.5	1240	3.66	279	2.38	62.5	440	1.39	162	1.41
34	1200	3.57	237	2.03	56	500	1.56	180	1.55
37.5	1130	3.39	256	2.19	52.5	570	1.76	177	1.53
40.5	1050	3.16	213	1.82	49.5	650	1.99	200	1.72
42.5	950	2.88	201	1.72	47.5	750	2.29	211	1.82
43.5	900	2.73	221	1.89	46.5	812	2.48	212	1.83
45	850	2.58	215	1.85	45	850	2.58	215	1.85

* P_s unit - kPa
 I_s unit = kPa-ms

TABLE 5. REFLECTED PRESSURE AND IMPULSE RATIOS VERSUS ANGLE OF INCIDENCE (CONT)

Station 2A, $P_g = 223, I_g = 105$				Station 2B, $P_g = 194, I_g = 100$					
Angle of Incidence degrees	REFL PRESS P_r kPa	PRESS REFL FACTOR P_r/P_g	REFL IMP I_r kPa-ms/kg ^{1/3}	IMP REFL FACTOR I_r/I_g	Angle of Incidence degrees	REFL PRESS P_r kPa	PRESS REFL FACTOR P_r/P_g	REFL IMP I_r kPa-ms/kg ^{1/3}	IMP REFL FACTOR I_r/I_g
0	760	3.41	240	2.29	90	194	1.00	94	0.94
10	690	3.09	232	2.21	80	205	1.03	104	1.03
16	650	2.93	230	2.19	74	224	1.11	110	1.09
21	650	2.94	220	2.10	69	240	1.18	116	1.14
27.5	650	2.95	210	2.02	62.5	277	1.34	129	1.26
34	640	2.94	195	1.88	56	325	1.55	140	1.36
37.5	620	2.86	192	1.85	52.5	370	1.75	149	1.45
40.5	510	2.59	183	1.76	49.5	410	1.93	152	1.48
42.5	520	2.42	175	1.08	47.5	430	2.02	151	1.47
43.5	520	2.33	170	1.65	46.5	460	2.16	164	1.59
45	480	2.25	173	1.68	45	480	2.25	173	1.68

TABLE 5. REFLECTED PRESSURE AND IMPULSE RATIOS VERSUS ANGLE OF INCIDENCE (CONT)

Station 3A, $P_s = 141$, $I_s = 88$				Station 3B, $P_s = 126$, $I_s = 84$					
Angle of Incidence degrees	REFL PRESS P_r kPa	PRESS REFL FACTOR P_r/P_s	REFL IMP I_r kPa-ms/kg ^{1/3}	IMP REFL FACTOR I_r/I_s	Angle of Incidence degrees	REFL PRESS P_r kPa	PRESS REFL FACTOR P_r/P_s	REFL IMP I_r kPa-ms/kg ^{1/3}	IMP REFL FACTOR I_r/I_s
0	433	3.07	172	1.95	90	126	1.00	81	0.96
10	431	3.06	165	1.88	80	160	1.25	94	1.11
16	420	2.98	163	1.85	74	184	1.40	96	1.13
21	405	2.89	159	1.81	69	206	1.57	97	1.13
27.5	390	2.81	155	1.76	62.5	235	1.77	112	1.30
34	360	2.61	140	1.59	56	275	2.05	118	1.36
37.5	365	2.64	134	1.52	52.5	305	2.26	123	1.41
40.5	380	2.77	134	1.54	49.5	330	2.43	127	1.46
42.5	380	2.77	131	1.51	47.5	348	2.56	127	1.46
43.5	385	2.81	136	1.56	46.5	352	2.66	131	1.51
45	390	2.87	138	1.59	45	390	2.87	138	1.59

TABLE 5. REFLECTED PRESSURE AND IMPULSE RATIOS VERSUS ANGLE OF INCIDENCE (CONT)

Station 4A, $P_s = 70.8$, $I_s = 69$				Station 4B, $P_s = 67.4$, $I_s = 67$			
Angle of Incidence degrees	REFL PRESS P_r kPa	PRESS REFL FACTOR P_r/P_s	REFL IMP I_r kPa-ms/kg $1/3$	Angle of Incidence degrees	REFL PRESS P_r kPa	PRESS REFL FACTOR P_r/P_s	REFL IMP I_r kPa-ms/kg $1/3$
			IMP REFL FACTOR I_r/I_s				IMP REFL FACTOR I_r/I_s
0	177	2.50	1.07	90	69	1.02	64
10	175	2.48	1.09	80	84	1.25	67
16	178	2.52	1.06	74	92	1.35	68
21	178	2.52	1.03	69	103	1.50	70
27.5	172	2.44	1.01	62.5	122	1.77	72
34	161	2.38	96	56	138	1.99	74
37.5	176	2.52	97	52.5	157	2.26	82
40.5	178	2.55	92	49.5	164	2.36	82
42.5	183	2.61	91	47.5	172	2.47	80
43.5	183	2.61	90	46.5	173	2.48	81
45	189	2.71	89	45	189	2.71	89

TABLE 5. REFLECTED PRESSURE AND IMPULSE RATIOS VERSUS ANGLE OF INCIDENCE (CONT)

Station 5A, $P_s = 40.8$, $I_s = 47$										Station 5B, $P_s = 39.4$, $I_s = 46$									
Angle of Incidence degrees	REFL PRESS P_r kPa	PRESS REFL FACTOR P_r/P_s	REFL IMP I_r kPa-ms/kg ^{1/3}	IMP REFL FACTOR I_r/I_s	Angle of Incidence degrees	REFL PRESS P_r kPa	PRESS REFL FACTOR P_r/P_s	REFL IMP I_r kPa-ms/kg ^{1/3}	IMP REFL FACTOR I_r/I_s	Angle of Incidence degrees	REFL PRESS P_r kPa	PRESS REFL FACTOR P_r/P_s	REFL IMP I_r kPa-ms/kg ^{1/3}	IMP REFL FACTOR I_r/I_s					
0	93	2.28	63	1.34	90	40	1.02	42	0.91										
10	89	2.18	62	1.32	80	48	1.21	44	0.96										
16	88	2.16	62	1.32	74	52	1.31	44	0.96										
21	87	2.14	62	1.32	69	60	1.50	41	1.00										
27.5	88	2.16	60	1.28	62.5	73	1.83	48	1.04										
34	84	2.07	59	1.25	56	83	2.06	49	1.04										
37.5	85	2.10	59	1.25	52.5	91	2.26	50	1.06										
40.5	87	2.15	59	1.25	49.5	94	2.34	50	1.06										
42.5	86	2.13	55	1.17	47.5	93	2.31	49	1.04										
43.5	85	2.10	56	1.19	46.5	91	2.25	50	1.06										
45	88	2.18	54	1.15	45	88	2.18	54	1.15										

TABLE 5. REFLECTED PRESSURE AND IMPULSE RATIOS VERSUS ANGLE OF INCIDENCE (CONT)

Station 6A, $P_g = 25.2, I_s = 35$				Station 6B, $P_g = 24.6, I_s = 35$					
Angle of Incidence degrees	REFL PRESS P_r kPa	PRESS REFL FACTOR P_r/P_s	REFL IMP I_r kPa-ms/kg ^{1/3}	IMP REFL FACTOR I_r/I_s	Angle of Incidence degrees	REFL PRESS P_r kPa	PRESS REFL FACTOR P_r/P_s	REFL IMP I_r kPa-ms/kg ^{1/3}	IMP REFL FACTOR I_r/I_s
0	56	2.22	39	1.11	90	25	1.02	32	0.91
10	56	2.22	39	1.11	80	29	1.17	33	0.94
16	52	2.06	38	1.09	74	32	1.30	34	0.97
21	50	1.98	38	1.09	69	38	1.53	36	1.03
27.5	52	2.07	38	1.09	62.5	48	1.93	37	1.06
34	51	2.03	37	1.06	56	52	2.09	37	1.06
37.5	52	2.07	38	1.09	52.5	54	2.17	38	1.09
40.5	50	2.00	37	1.06	49.5	53	2.12	38	1.09
42.5	50	2.00	36	1.03	47.5	51	2.04	39	1.11
43.5	50	2.009	36	1.03	46.5	52	2.08	38	1.09
45	52	2.08	38	1.09	45	52	2.08	38	1.09

TABLE 5. REFLECTED PRESSURE AND IMPULSE RATIOS VERSUS ANGLE OF INCIDENCE (CONT)

Station 7A, $P_s = 14.2$, $I_s = 25$				Station 7B, $P_s = 14.0$, $I_s = 25$					
Angle of Incidence degrees	REFL PRESS P_r kPa	PRESS REFL FACTOR P_r/P_s	REFL IMP I_r kPa-ms/kg ^{1/3}	IMP REFL FACTOR I_r/I_s	Angle of Incidence degrees	REFL PRESS P_r kPa	PRESS REFL FACTOR P_r/P_s	REFL IMP I_r kPa-ms/kg ^{1/3}	IMP REFL FACTOR I_r/I_s
0	30	2.11	28.7	1.15	90	14	1.00	25.0	1.00
10	29	2.04	28.0	1.12	80	16	1.14	25.0	1.00
16	29	2.04	28.0	1.12	74	20	1.43	26.0	1.04
21	29	2.04	28.0	1.12	69	22	1.57	27.0	1.08
27.5	26	1.83	28.0	1.12	62.5	25	1.79	25.0	1.00
34	25	1.77	28.0	1.12	56	26	1.84	26.0	1.04
37.5	26	1.84	28.0	1.12	52.5	26	1.84	26.0	1.04
40.5	25	1.77	27.5	1.10	49.5	26	1.84	26.0	1.04
42.5	25	1.77	27.5	1.10	47.5	26	1.84	26.0	1.04
43.5	25	1.77	28.0	1.12	46.5	25	1.80	27.0	1.08
45	25	1.80	28.0	1.12	45	25	1.80	28.0	1.12

TABLE 5. REFLECTED PRESSURE AND IMPULSE RATIOS VERSUS ANGLE OF INCIDENCE (CONT)

Station 8A, $P_s = 6.32$, $I_s = 15.5$				Station 8B, $P_s = 6.22$, $I_s = 15.4$					
Angle of Incidence degrees	REFL PRESS P_r kPa	PRESS REFL FACTOR P_r/P_s	REFL IMP I_r kPa-ms/kg ^{1/3}	IMP REFL FACTOR I_r/I_s	Angle of Incidence degrees	REFL PRESS P_r kPa	PRESS REFL FACTOR P_r/P_s	REFL IMP I_r kPa-ms/kg ^{1/3}	IMP REFL FACTOR I_r/I_s
0	13.2	2.09	14.2	0.92	90	7.2	1.16	12.6	0.82
10	13.5	2.14	14.2	0.92	80	8.2	1.31	12.2	0.79
16	14.0	2.21	14.8	0.95	74	9.9	1.58	13.2	0.86
21	14.0	2.21	15.6	1.01	69	11.0	1.76	13.1	0.85
27.5	12.4	1.97	14.6	0.94	62.5	10.9	1.74	13.1	0.85
34	11.2	1.77	14.5	0.94	56	10.5	1.67	13.1	0.85
37.5	11.3	1.79	14.5	0.94	52.5	10.9	1.74	13.0	0.84
40.5	11.3	1.79	14.4	0.93	49.5	11.0	1.75	14.0	0.91
42.5	11.1	1.76	13.9	0.90	47.5	11.0	1.75	13.5	0.88
43.5	10.8	1.72	13.8	0.89	46.5	11.0	1.75	13.5	0.88
45	11.4	1.81	14.3	0.93	45	11.4	1.81	14.3	0.93

pressure (P_g) for a θ of 0 degrees is listed for Station A and the P_g for 90 degrees is listed for Station B. The P_g for each radial distance from $\theta = 0$ degree through $\theta = 90$ degrees was calculated to insure that the correct P_g for each angle was used in determining the ratio P_r/P_g . The values listed in Table 5 are plotted in Figures 14 and 15.

The reflected impulse ratios listed in Table 5 are based on the reflected impulse curves plotted in Figure 13 and the side-on impulse listed in Table 4 adjusted for the R distance between Station A and B. The range of side-on impulses is listed for each station in Table 5. The values of reflected impulse I_r divided by the side-on impulse I_g listed in Table 5 are plotted in Figure 16.

IV. DISCUSSION

The data tables and plotted curves presented in the Results section show trends of the effects on reflected pressure and impulse, of the angle of incidence of the shock front striking an isolated structure. Some of these trends follow theory and predictions as presented in the Predictive Approach of the Test Procedures section while other results are different.

A. Reflected Pressure in the Regular and Mach Reflection Regions

The curve showing reflective pressure (P_r) as a function of incident pressure (P_g) for all angles of incidence in the regular reflection region is shown in Figure 17. This curve is quite similar to the family of curves presented in Figure 7. Note in Figure 7 the slope angles are identified rather than the angle of incidence. The spread of data is indicated by the band at each station location. This means that when a particular station receives the same incident pressure (P_g) and as the model is rotated to change the angle of incidence the reflected pressure (P_r) does not change greatly in the regular reflection region. This is shown graphically in Figure 12.

The family of curves presented in Figure 18 show a trend similar to that presented in Figure 8 for pressure enhancement in the Mach reflection region. The quantitative values are higher in Figure 8 than measured experimentally in Figure 18. This difference is because the measured values from this series did not record the enhancement at the transition zone from the regular reflection region to the Mach reflection region as shown in Figure 9. The enhancement shown in Figure 9 is of very short duration and would have little effect on impulse in the blast wave.

B. Reflected Impulse in the Regular and Mach Reflection Regions

The reflected impulse versus incident impulse and angle of incidence is presented in Figure 13. A variation of this presentation is made in Figure 19 where the data is plotted for reflected impulse I_r as a function of incident impulse (I_g) in the regular reflection region. The two solid lines show the variation in reflected impulse measured on an isolated structure when the angle of incidence is in the regular reflection region.

- - $P_s = 346 - 294$
- - $P_s = 223 - 144$
- △ - $P_s = 141 - 126$
- - $P_s = 70.8 - 67.4$

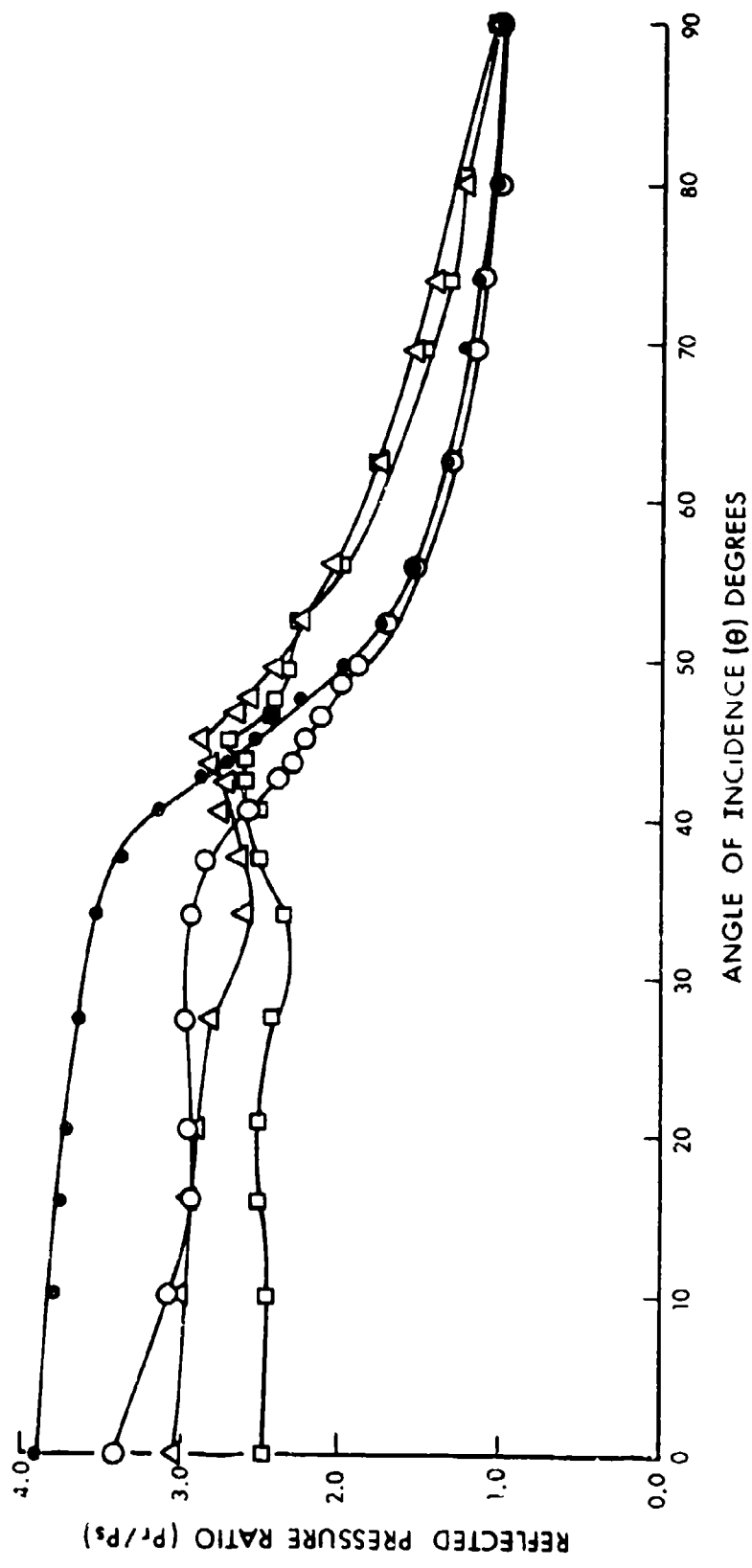

Figure 14. Reflected Pressure Ratios (P_r/P_s) versus Angle of Incidence for P_s from 346 kPa to 67.4 kPa.

- P_s 40.8 - 39.4
- P_s 25.2 - 24.6
- △ P_s 14.2 - 14.0
- P_s 6.3 - 6.2

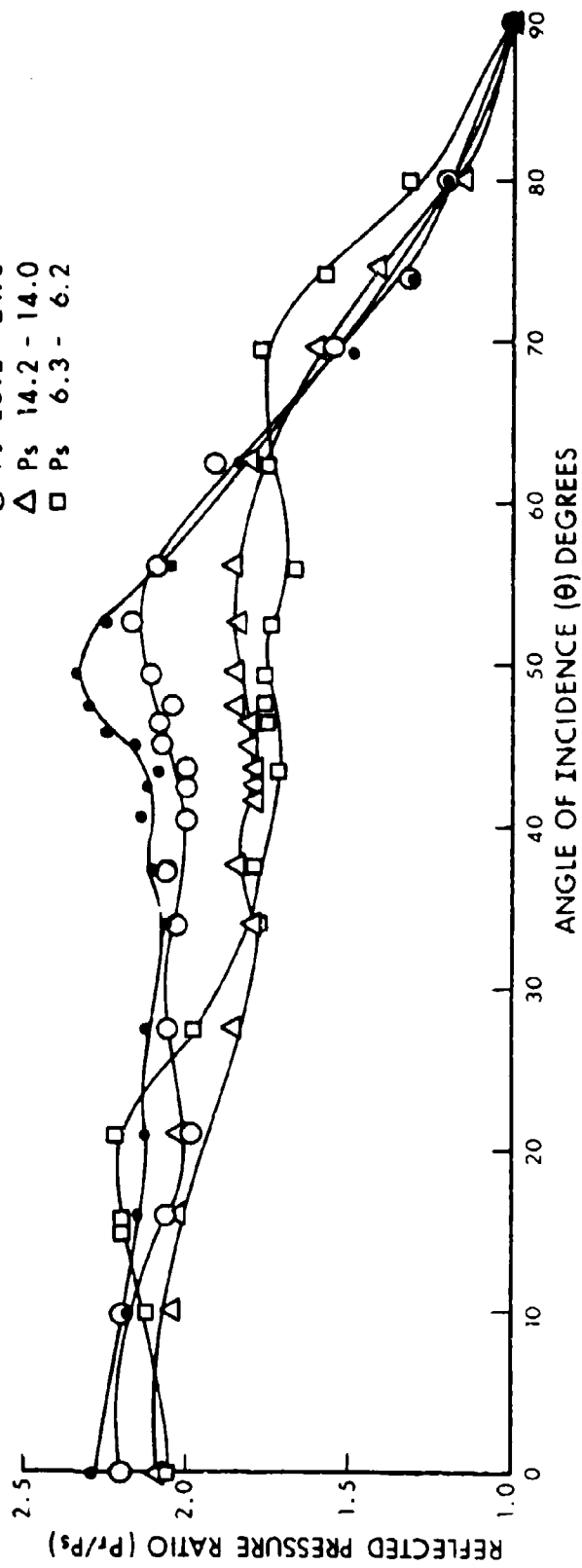

Figure 15. Reflected Pressure Ratios (P_r/P_s) versus Angle of Incidence for P_s from 40.8 kPa to 6.2 kPa.

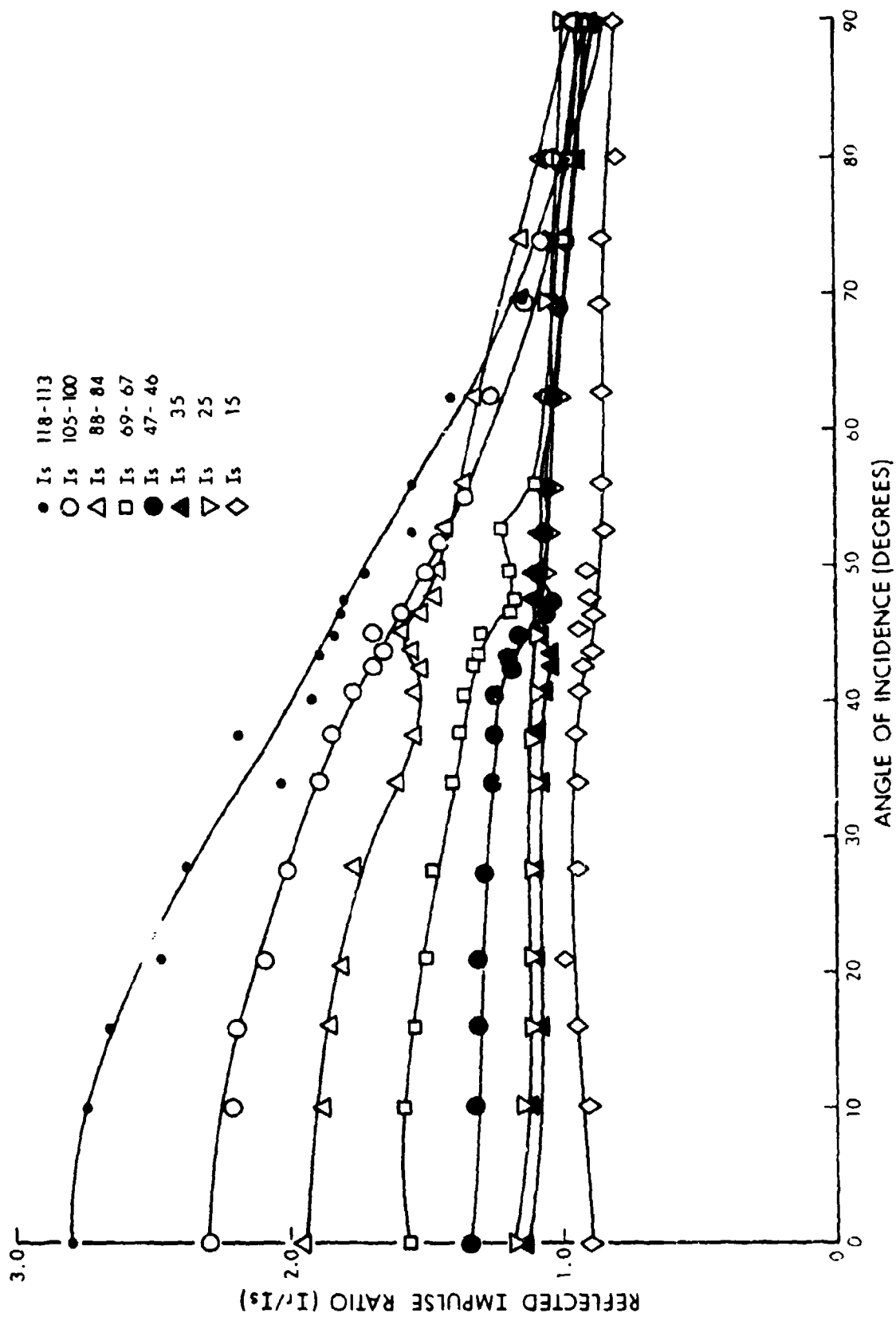

Figure 16. Reflected Impulse Ratios (I_r/I_s) versus Angle of Incidence.

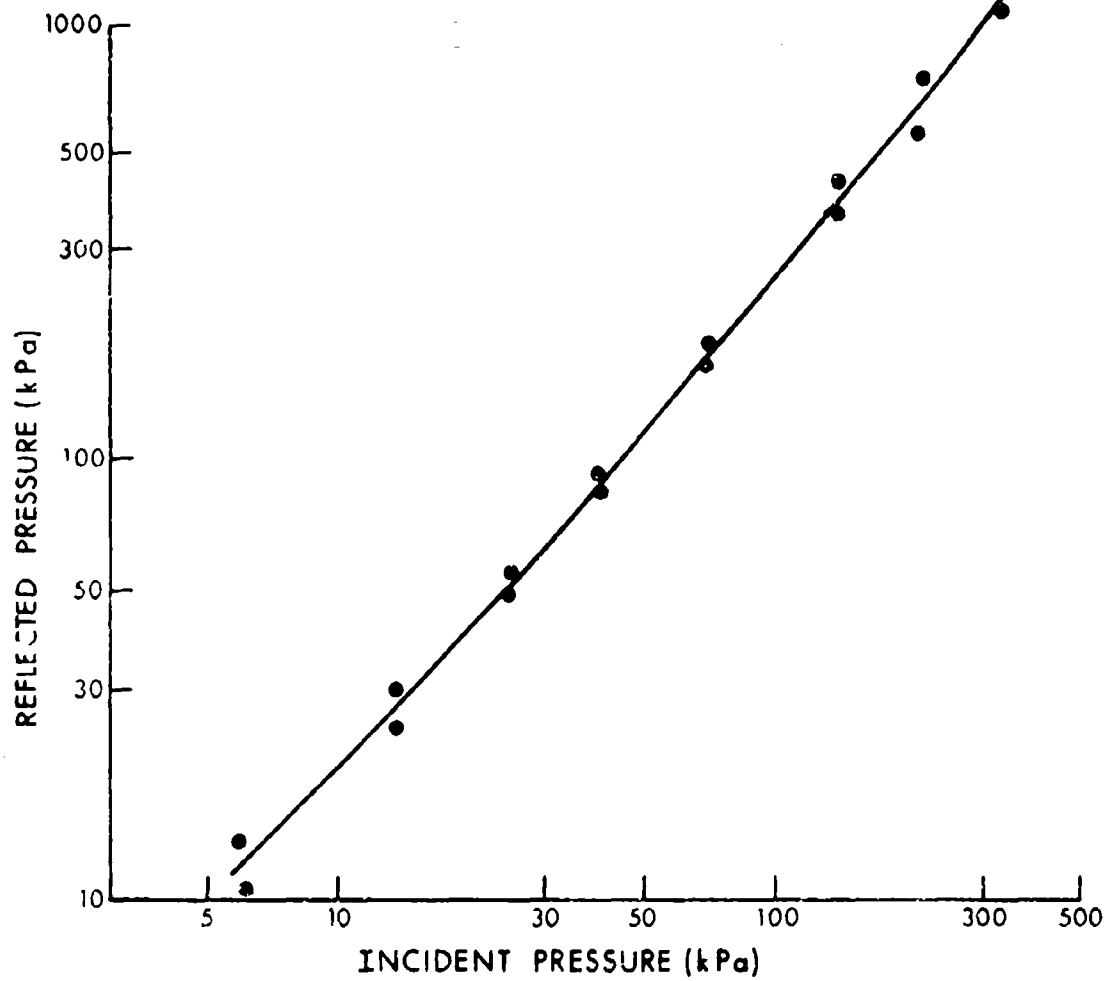

Figure 17. Reflected Pressure versus Incident Pressure in the Regular Reflection Region.

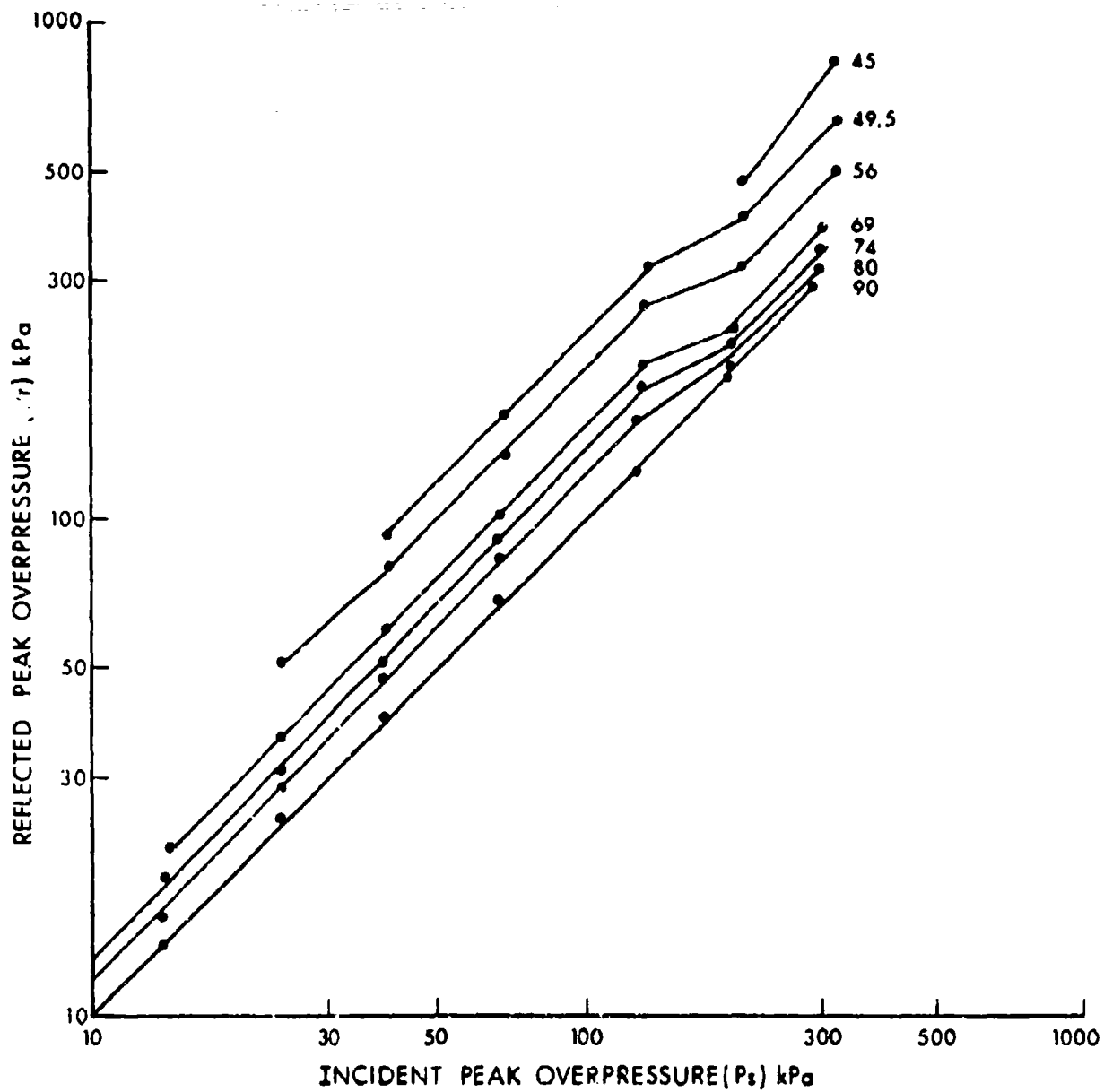

Figure 18. Reflected Pressure (P_r) versus Incident Pressure (P_i) in the Mach Reflection Region as a Function of Angle of Incidence.

The dashed line presented in Figure 19 is to show the difference in the zero degree or head-on reflected impulse on an infinite plane and that recorded on a finite model. The lower values recorded on the model are because the arrival of the rarefaction waves from the sides of the structure causes an increase in the rate of decay of the reflection pressure which produces a lower reflected impulse.

The reflected impulse recorded in the Mach reflection region is plotted in Figure 13 and presented in a different manner in Figure 20. In this figure the enhancement of reflected impulse becomes less as the angle of incidence approaches 90 degrees, or side-on conditions. The vortex from the front corner of the structure causes a lowering of the overpressure during the passage of the blast wave and the reflected impulse becomes less than the side-on impulse at an angle of incidence of 90 degrees. This is also true at some of the values measured at an 80 degree angle of incidence.

V. CONCLUSIONS

The results presented in this report are based on one size structure and one charge mass. Therefore it cannot be applied in general to all size structures and all charge masses. The model was 0.3048m x 0.3048m x 0.4572m exposed to a 1 kg charge mass. This means the results could be applied to structures where the size is increased by the cube root of the charge mass, for example, a 1000 kg charge mass and a 3.048 metre structure or a 125000 kg charge and a 15.24 metre structure or a 512000 kg charge mass and a 24.38 metre structure 36.58 metres high. Care would have to be exercised in applying the results to other combinations of charge mass and structure dimensions. If a charge mass is held constant and the structure size increased, the reflected impulse values in the regular reflection region would approach the infinite plane case.

ACKNOWLEDGEMENTS

The authors wish to acknowledge the outstanding work of Mr. S. Dunbar, the electrical engineer in charge of the instrumentation facility, who was responsible for recording all of the overpressure versus time data. He also processed the analog magnetic data tape through the data conversion computers to produce the information in digital form for plotting and analysis.

The authors also wish to acknowledge the work of Mr. K. Holbrook, technician and explosive handler for the excellent job done in site preparation, blast line installation, and model instrumentation and placement.

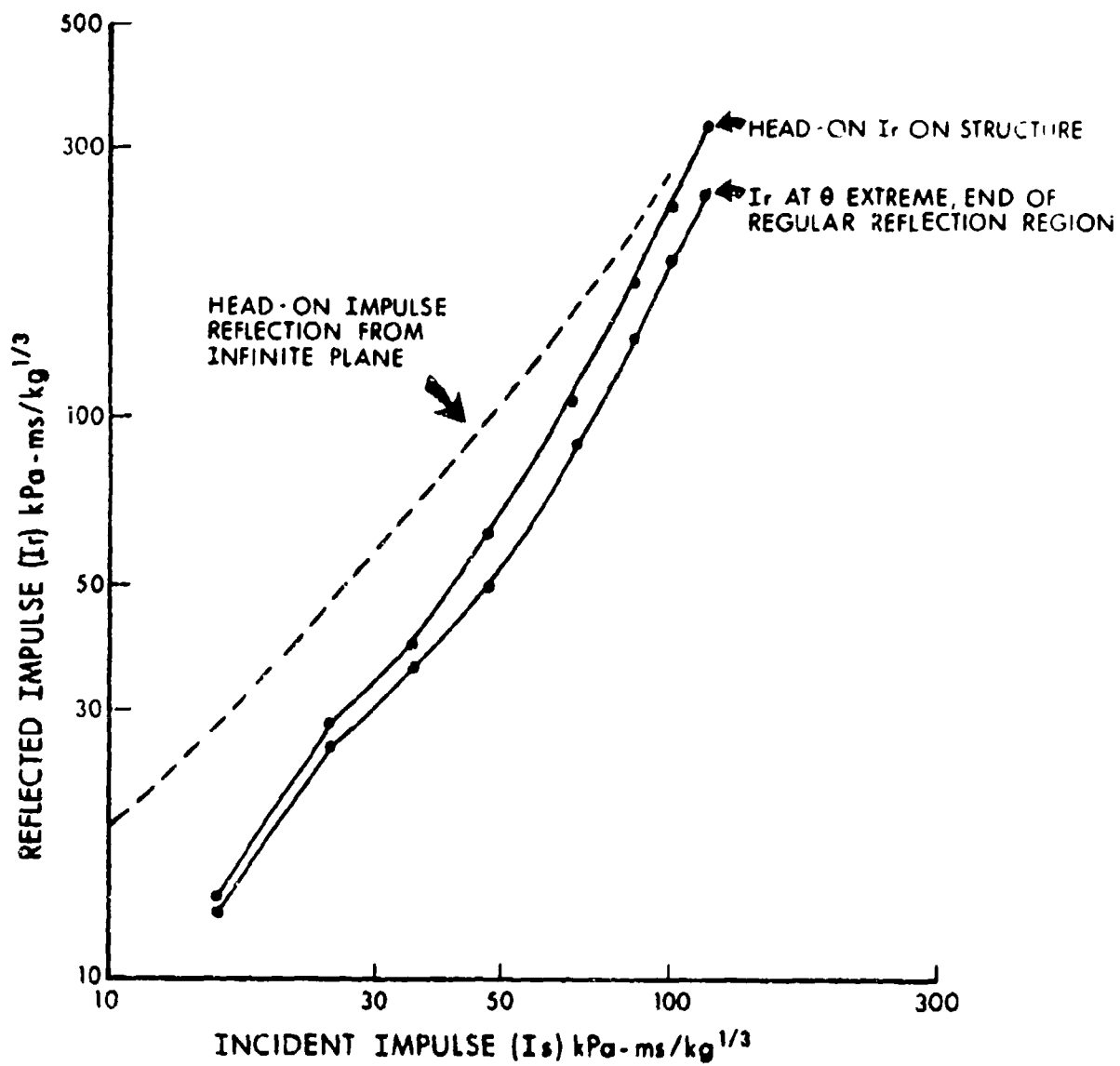

Figure 19. Scaled Reflected Impulse (I_r) versus Scaled Incident Impulse (I_s) in the Regular Reflection Region.

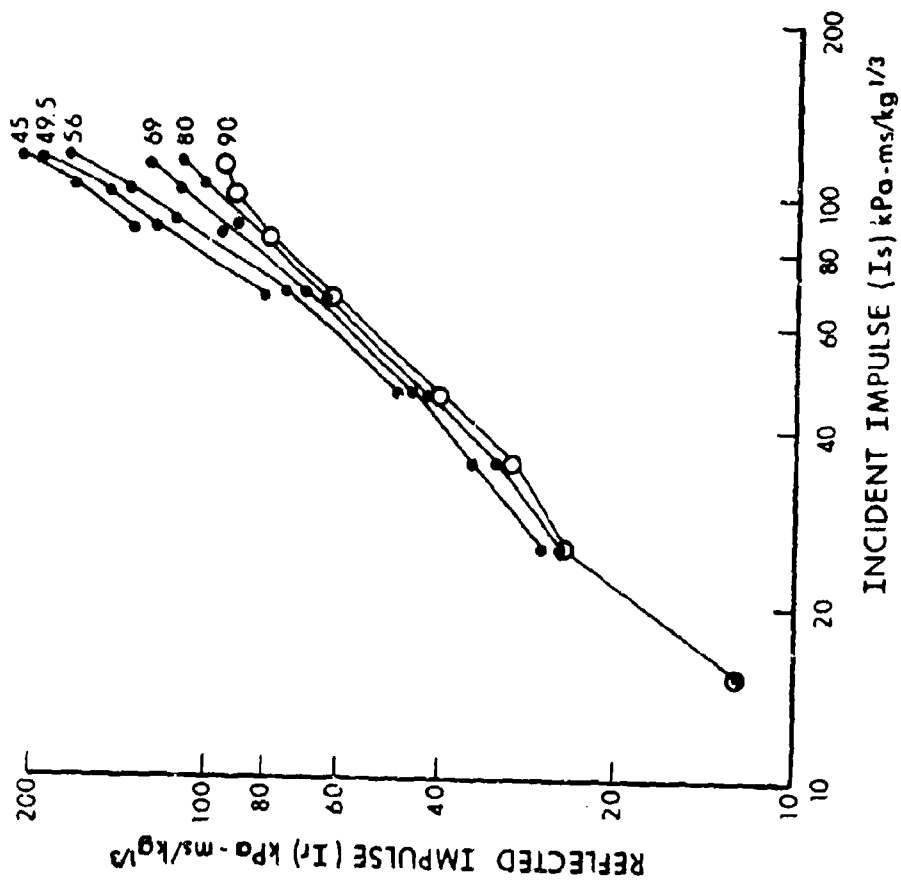

Figure 20. Scaled Reflected Impulse (I_r) versus Scaled Incident Impulse (I_s) in the Mach Reflection Region as a Function of Angle of Incidence.

LIST OF REFERENCES

1. Department of the Army, the Navy, and the Air Force, "Structures to Resist the Effects of Accidental Explosions," June 1969, TMS-1300, NAVFAC P-397, AFM 88-22.
2. R.E. Reisler, B. Pettit and L. Kennedy, "Air Blast Data from Height of Burst Studies in Canada, Vol I: HOB 5.4 to 71.9 Feet," BRL Report No. 1950, December 1976 (AD B016344L).
3. R.E. Reisler, B. Pettit and L. Kennedy, "Air Blast Data from Height of Burst Studies in Canada, Vol II: HOB 4.5 to 144.5 Feet," BRL Report No. 1990, May 1977.
4. C.N. Kingery, "Air Blast Parameters versus Distance for Hemispherical Surface Bursts," BRL Report 1344, September 1966 (AD 811673).
5. "Nuclear Weapons Blast Phenomena, Vol.II, Blast Wave Interaction," DASA 1200-II, 1 December 1970 (Confidential RD).
6. C.N. Kingery and B.F. Pannill, "Parametric Analysis of Regular Reflection of Air Blast," BRL Report 1249, June 1964 (AD 444997).
7. Kenneth Kaplan, "Effects of Terrain on Blast Prediction Methods and Prediction," BRL Contract Report ARBRL-CR-00355, January 1978 (AD A051350).
8. H.L. Brode, "Height of Burst Effects at High Overpressures," The Rand Corporation, RM-6301, DASA 2506, July 1970.
9. Charles Kingery and George Coulter, "TNT Equivalency of Pentolite Hemispheres," ARBRL-TR-02456, December 1982 (AD A123340).

DISTRIBUTION LIST

<u>No. of Copies</u>	<u>Organization</u>	<u>No. of Copies</u>	<u>Organization</u>
12	Administrator Defense Technical Information Center ATTN: DTIC-DDA Cameron Station Alexandria, VA 22314	5	Chairman DOD Explosives Safety Board Room 856-C, Hoffman Bldg. I 2461 Eisenhower Avenue Alexandria, VA 22331
1	Office Secretary of Defense ADUSDRE (R/AT) (ET) ATTN: Mr. J. Persh, Staff Specialist, Materials and Structures Washington, DC 20301	1	Commander US Army Missile Command ATTN: DRSMI-YDL Redstone Arsenal, AL 35898
1	Under Secretary of Defense for Research and Engineering Department of Defense Washington, DC 20301	3	Director Institute for Defense Analysis ATTN: Dr. H. Menkes Dr. J. Bengston Tech Info Ofc 1801 Beauregard St. Alexandria, VA 22311
1	Director of Defense Research and Engineering Washington, DC 20301	2	Chairman Joint Chiefs of Staff ATTN: J-3, Operations J-5, Plans & Policy (R&D Division) Washington, DC 20301
1	Assistant Secretary of Defense (MRA&L) ATTN: EO&SP Washington, DC 20301	1	Director Defense Communications Agency ATTN: NMCSSC (Code 510) 8th St. and S. Courthouse Rd. Washington, DC 20305
1	Assistant Secretary of Defense (Atomic Energy) ATTN: Document Control Washington, DC 20301	4	Director Defense Nuclear Agency ATTN: SPTD, Mr. T.E. Kennedy LDST (F), Dr. E. Sevin OALG, Mr. T.P. Jeffers LEEF, Mr. J. Eddy Washington, DC 20305
1	Director Defense Advanced Research Projects Agency 1400 Wilson Boulevard Arlington, VA 22209	1	Commander US Army Missile Command ATTN: DRSMI-RR, Mr. L. Lively Redstone Arsenal, AL 35898
1	Director Defense Intelligence Agency ATTN: DT-1B, Dr. J. Vorona Washington, DC 20301		

DISTRIBUTION LIST

<u>No. of Copies</u>	<u>Organization</u>	<u>No. of Copies</u>	<u>Organization</u>
1	DNA Information and Analysis Center Kaman Tempo ATTN: DASIAC 816 State Street P.O. Drawer 00 Santa Barbara, CA 93102	1	AFFDL (FBE) Wright-Patterson AFB OH 45433
1	Commander Air Force Armament Laboratory ATTN: DLYV, Mr. R.L. McGuire Eglin AFB, FL 32542	1	AFLC (MMWM/CPT D. Rideout) Wright-Patterson AFB, OH 45433
1	Ogden ALC/MMWRE ATTN: (Mr. Ted E. Comins) Hill AFB, UT 84406	1	AFML (IGYE/K. Shopker) Wright-Patterson AFB, OH 45433
4	AFWL/SUL, NTES, NTE, NTES Kirtland AFB, NM 87117	1	AFML (LLN, Dr. T. Nicholas) Wright-Patterson AFB, OH 45433
1	AFML (MBC/D. Schmidt) Wright-Patterson AFB, OH 45433	1	AFML (MAS) Wright-Patterson AFB, OH 45433
1	Director of Aerospace Safety HQ, USAF ATTN: JGD/AFISC (SEVV), COL J.E. McQueen Norton AFB, CA 92409	1	FTD (ETD) Wright-Patterson AFB OH 45433
2	HQ, USAF ATTN: IDG/AFISC, (SEW)W.F. Gavitt, Jr. (SEV)Mr. K.R. Shopher Norton AFB, CA 92409	1	Mr. Richard W. Watson Director, Pittsburgh Mining & Safety Research Center Bureau of Mines, Dept of the Interior 4800 Forbes Avenue Pittsburgh, PA 15213
2	Director Joint Strategic Target Planning Staff ATTN: JLTW; TPTP Offutt AFB Omaha, NB 68113	1	Headquarters Energy Research and Development Administration Department of Military Applications Washington, DC 20545
1	HQ AFESC/RDL RDC Walter Buckholtz Tyndal AFB, FL 32403	1	Director Office of Operational and Environmental Safety US Department of Energy Washington, DC 20545
1	AFCEC (DE-LTC Walkup) Tyndall AFB, FL 32403	1	Commander US Army Armament Materiel Readiness Command ATTN: DRSAR-LEP-L Rock Island, IL 61299

DISTRIBUTION LIST

<u>No. of Copies</u>	<u>Organization</u>	<u>No. of Copies</u>	<u>Organization</u>
1	Albuquerque Operations Office US Department of Energy ATTN: Div of Operational Safety P.O. Box 5400 Albuquerque, NM 87115	1	Commander US Army Harry Diamond Labs ATTN: DELHD-TI 2800 Powder Mill Road Adelphi, MD 20783
1	Commander US Army Aviation Research and Development Command ATTN: DRDAV-E 4300 Goodfellow Blvd St. Louis, MO 63120	1	Commander US Army Missile Command ATTN: DRSMI-R Redstone Arsenal, AL 35898
1	Director US Army Air Mobility Research and Development Laboratory Ames Research Center Moffett Field, CA 94035	1	Commander US Army Missile Command ATTN: DRSMI-RX, Mr. W. Thomas Redstone Arsenal, AL 35898
2	Director Lewis Directorate US Army Air Mobility Research and Development Laboratory Lewis Research Center ATTN: Mail Stop 77-5 21000 Brookpark Road Cleveland, OH 44135	1	Commander US Army Mobility Equipment Research & Development Command ATTN: DRDFB-ND, Mr. R.L. Brooke Fort Belvoir, VA 22060
2	Commander US Army Communications Research and Development Command ATTN: DRDCO-PPA-SA DRSEL-ATDD Fort Monmouth, NJ 07703	1	Commander US Army Natick Research and Development Command ATTN: DRDNA-D, Dr. D. Seiling Natick, MA 01762
1	Commander US Army Electronics Research and Development Command Technical Support Activity ATTN: DELSD-L Fort Monmouth, NJ 07703	3	Commander US Army Tank Automotive Command ATTN: DRSTA-TSL DRSTA-TL DRSTA-UL Warren, MI 48090
		1	Commander Dugway Proving Ground ATTN: STEDP-TO-H, Mr. Miller Dugway, UT 84022

DISTRIBUTION LIST

<u>No. of Copies</u>	<u>Organization</u>	<u>No. of Copies</u>	<u>Organization</u>
1	Commander US Army Foreign Science and Technology Center ATTN: RSCH & Data Branch Federal Office Building 220-7th Street, NE Charlottesville, VA 22901	1	Commander US Army Rock Island Arsenal Rock Island, IL 61299
1	Commander US Army Materials and Mechanics Research Center ATTN: DRXMR-ATL Watertown, MA 02172	1	Director US Army ARRADCOM Benet Weapons Laboratory ATTN: DRDAR-LCB-TL Watervliet, NY 12189
1	Director DARCOM, ITC ATTN: Dr. Chiang Red River Depot Texarkana, TX 75501	2	Commandant US Army Infantry School ATTN: ATSH-CD-CSO-OR Fort Benning, GA 31905
1	Commander US Army Armament Research and Development Command ATTN: DRDAR-LCM-SP Dover, NJ 07801	1	Commander Cornhusker Army Ammunition Plant Grand Island, NE 68801
2	Commander US Army Armament Material Readiness Command ATTN: Joint Army-Navy-Air Force Conventional Ammunition Prof Coord GP/EI Jordan Rock Island, IL 61299	1	Commander Iowa Army Ammunition Plant Burlington, IA 52502
3	Commander US Army Armament Research and Development Command ATTN: DRDAR-TSS DRDAR-TDC Dover, NJ 07801	1	Commander Indiana Army Ammunition Plant Charlestown, IN 47111
1	Commander Pine Bluff Arsenal Pine Bluff, AR 71601	1	Commander Joliet Army Ammunition Plant Joliet, IL 60436
		1	Commander Kansas Army Ammunition Plant Parsons, KS 67357
		1	Commander Lone Star Army Ammunition Plant Texarkana, TX 75502
		1	Commander Longhorn Army Ammunition Plant Marshall, TX 75671
		1	Commander Louisiana Army Ammunition Plant Shreveport, LA 71102

DISTRIBUTION LIST

<u>No. of Copies</u>	<u>Organization</u>	<u>No. of Copies</u>	<u>Organization</u>
1	Commander Milan Army Ammunition Plant Milan, TN 38358	1	HQDA (DAEN-ECE-T/Mr. R.L. Wright) Washington, DC 20310
1	Commander Radford Army Ammunition Plant Radford, VA 24141	1	Director US Army BMD Advanced Technology Center ATTN: M. Whitfield P.O. Box 1500 Huntsville, AL 35807
1	Commander Ravenna Army Ammunition Plant Ravenna, OH 44266	1	Commander US Army Ballistic Missile Defense Systems Command ATTN: J. Veeneman P.O. Box 1500 Huntsville, AL 35807
1	Commander Field Command Defense Nuclear Agency ATTN: Tech Lib, FCWS-SC Kirtland AFB, NM 87115	1	Commander US Army Engineer Waterways Experiment Station ATTN: WESNP P.O. Box 631 Vicksburg, MS 39181
1	HQDA (DAMA-CSM-CA) Washington, DC 20310	1	Commander US Army Materiel Development and Readiness Command ATTN: DRCSF 5001 Eisenhower Avenue Alexandria, VA 22333
1	HQDA (DAMA-AR; NCL Div) Washington, DC 20310	1	Commander US Army Materiel Development and Readiness Command ATTN: DRCDMD-SI 5001 Eisenhower Avenue Alexandria, VA 22333
1	HQDA (DAMA-NCC, COL R.D. Orton) Washington, DC 20310	1	Director DARCOM Field Safety Activity ATTN: DRXOSOES Charlestown, IN 47111
1	HQDA (DAEN-RDL, Mr. Simonini) Washington, DC 20310	1	Director DARCOM Field Safety Activity ATTN: DRXOSOES Charlestown, IN 47111
1	HQDA (DAEN-RDZ-A, Dr. Choromokos) Washington, DC 20310	1	Director DARCOM Field Safety Activity ATTN: DRXOSOES Charlestown, IN 47111
1	Commander US Army Europe ATTN: AEAGA-BE, Mr. P. Morgan APO New York, NY 09801	1	Director DARCOM Field Safety Activity ATTN: DRXOSOES Charlestown, IN 47111
1	HQDA (DAPE-HRS) Washington, DC 20310	1	Director DARCOM Field Safety Activity ATTN: DRXOSOES Charlestown, IN 47111
1	HQDA (DAEN-MCC-D/Mr. L. Foley) Washington, DC 20310	1	Director DARCOM Field Safety Activity ATTN: DRXOSOES Charlestown, IN 47111

DISTRIBUTION LIST

<u>No. of Copies</u>	<u>Organization</u>	<u>No. of Copies</u>	<u>Organization</u>
1	Office of the Inspector General Department of the Army ATTN: DAIG-SD Washington, DC 20310	1	Chief of Research, Development, and Acquisition Department of the Army ATTN: DAMA-CSN-CA, LTC V. F. Burrell Washington, DC 20310
1	US Army Engineer Div. Europe ATTN: EUDED, Mr. N. Howard APO New York, NY 09757	1	Assistant Secretary of the Navy (Rsch & Dev) Navy Development Washington, DC 20350
1	Commander US Army Research Office P.O. Box 12211 Research Triangle Park NC 27709	2	Chief of Naval Operation ATTN: OP-411, C. Ferraro, Jr. OP-41B, CAPT V.E. Strickland Washington, DC 20350
1	Director US Army TRADOC Systems Analysis Activity ATTN: ATTA-SL White Sands Missile Range NM 88002	1	Commander Naval Air Systems Command ATTN: AIR-532 Washington, DC 20360
1	Division Engineer US Army Engineer Division Fort Belvoir, VA 22060	3	Commander Naval Sea Systems Command ATTN: SEA-62R, SEA-62Y, SEA-9961 Washington, DC 20360
1	US Army Engineer Division ATTN: Mr. Char P.O. Box 1600 Huntsville, AL 35809	1	Commander US Army Missile Command ATTN: DRSMI-RSS, Mr. Bob Cobb Redstone Arsenal, AL 35898
1	Commandant US Army Engineer School ATTN: ATSE-CD Fort Belvoir, VA 22060	1	Commander Naval Facilities Engineering Command ATTN: Code 045 200 Stoval Street Alexandria, VA 22332
1	Commander US Army Construction Engineering Research Lab P.O. Box 4005 Champaign, IL 61820		

DISTRIBUTION LIST

<u>No. of Copies</u>	<u>Organization</u>	<u>No. of Copies</u>	<u>Organization</u>
2	Commander David W. Taylor Naval Ship Research & Development Center ATTN: Mr. A. Wilner, CODE 1747 Mr. W.W. Murray, CODE 17 Bethesda, MD 20084	1	Officer in Charge Naval EOD Facility ATTN: Code D, Mr. L. Dickenson Indian Head, MD 20640
3	Commander Naval Surface Weapons Center ATTN: Dr. Leon Schindel Dr. Victor Dawson Dr. P. Huang Silver Spring, MD 20910	1	Commander Naval Weapons Evaluation Facility ATTN: Document Control Kirtland AFB Albuquerque, NM 87117
1	Commander Naval Surface Weapons Center White Oak Laboratory ATTN: R-15, Mr. M.M. Swisdak Silver Spring, MD 20910	1	Commander Naval Research Laboratory ATTN: Code 2027, Tech Lib Washington, DC 20375
1	Commander Naval Surface Weapons Center Dahlgren Laboratory ATTN: E-23, Mr. J.J. Walsh Dahlgren, VA 22448	1	Officer in Charge (Code L31) Civil Engineering Lab ATTN: Code L51, Mr. W.A. Keenan Naval Construction Battalion Center Port Hueneme, CA 93041
1	Commander Naval Weapons Center ATTN: Code 0632, Mr. G. Ostermann China Lake, CA 93555	2	Superintendent Naval Postgraduate School ATTN: Tech Reports Sec. Code 57, Prof. R. Ball Monterey, CA 93940
1	Commander Naval Ship Research and Development Center Facility ATTN: Mr. Lowell T. Butt Underwater Explosions Research Division Portsmouth, VA 23709	1	Commander Bureau of Naval Weapons Department of the Navy Washington, DC 20360
1	Commanding Officer Naval Weapons Support Center Crane, IN 47522	1	HQ USAF (AFNIE-CA) Washington, DC 20330
		3	HQ USAF (AFRIDO; AFRDXM; AFRDPM) Washington, DC 20330
		1	AFTAWC (OA) Eglin AFB, FL 32542

DISTRIBUTION LIST

<u>No. of Copies</u>	<u>Organization</u>	<u>No. of Copies</u>	<u>Organization</u>
1	Air Force Systems Command /SDOA ATTN: IGFG Andrews AFB, MD 20334	1	Director National Aeronautics and Space Administration Marshall Space Flight Center Huntsville, AL 35812
1	AFRPL Edwards AFB, CA 93523	2	Director National Aeronautics and Space Administration Aerospace Safety Research and Data Institute ATTN: Mr. S. Weiss, Mail Stop 6-2 Mr. R. Kemp, Mail Stop 6-2 Lewis Research Center 21000 Brookpark Road Cleveland, OH 44135
1	ADTC (DLIDL, Tech Lib) Eglin AFB, FL 32542	1	Director National Aeronautics and Space Administration Scientific and Technical Information Facility P.O. Box 8757 Baltimore/Washington International Airport MD 21240
1	ADTC Eglin AFB, FL 32542	1	National Academy of Science ATTN: Mr. D.G. Groves 2101 Constitution Avenue, NW Washington, DC 20419
1	Institute of Makers of Explosives ATTN: Mr. Harry Hampton Graybar Buildings, Rm 2449 420 Lexington Avenue New York, NY 10017	1	Aeronautical Research Associates of Princeton, Inc. ATTN: Dr. C. Donaldson 50 Washington Road, PO Box 2229 Princeton, NJ 08540
1	Institute of Makers of Explosives ATTN: Mr. F.P. Smith, Jr., Executive Director 1575 Eye St., N.W. Washington, DC 20005	1	Aerospace Corporation P.O. Box 92957 Los Angeles, CA 90009
1	Director Lawrence Livermore Laboratory Technical Information Division P.O. Box 808 Livermore, CA 94550	1	Aghabian Associates ATTN: Dr. D. P. Reddy 250 N. Nash Street El Segundo, CA 90245
1	Director Los Alamos Scientific Lab ATTN: Dr. J. Taylor P.O. Box 1663 Los Alamos, NM 87545		
2	Director Sandia Laboratories ATTN: Info Dist Div Dr. W.A. von Riesenmann Albuquerque, NM 87115		

DISTRIBUTION LIST

<u>No. of Copies</u>	<u>Organization</u>	<u>No. of Copies</u>	<u>Organization</u>
2	AVCO Systems Division Structures and Mechanics Dept. ATTN: Dr. William Broding Dr. J. Gilmore 201 Lowell Street Wilmington, MA 01887	1	J.G. Engineering Research Associates 3831 Menlo Drive Baltimore, MD 21215
2	Battelle Memorial Institute ATTN: Dr. L.E. Hulbert Mr. J.E. Backofen, Jr. 505 King Avenue Columbus, OH 43201	3	Kaman-Nuclear ATTN: Dr. F.H. Shelton Dr. D. Sachs Dr. R. Keffe 1500 Garden of the Gods Road Colorado Springs, CO 80907
1	Black & Veatch Consulting Engineers ATTN: Mr. H.L. Callahan 1500 Meadow Lake Parkway Kansas City, MO 64114	1	Knolls Atomic Power Laboratory ATTN: Dr. R.A. Powell Schenectady, NY 12309
2	The Boeing Company Aerospace Group ATTN: Dr. Peter Grafton Dr. D. Strome Mail Stop 8C-68 P.O. Box 3707 Seattle, WA 98124	1	Lovelace Research Institute ATTN: Dr. E.R. Fletcher P.O. Box 5890 Albuquerque, NM 87115
1	General American Transportation Corp. General American Research Div. ATTN: Dr. J.C. Shang 7449 N. Natchez Avenue Niles, IL 60548	2	Martin Marietta Corporation ATTN: Dr. P.F. Jordan Mr. R. Goldman 1450 S. Rolling Road Baltimore, MD 21227
1	Hercules, Inc. ATTN: Billings Brown Box 93 Magna, UT 84044	1	Mason & Hanger-Silas Mason Co., Inc. Pantex Plant ATTN: Director of Development P.O. Box 647 Amarillo, TX 79117
2	Kaman-AviDyne ATTN: Dr. N.P. Hobbs Mr. S. Criscione Northwest Industrial Park 83 Second Avenue Burlington, MA 01803	1	McDonnell Douglas Astronautics Western Division ATTN: Dr. Lea Cohen 5301 Bolsa Avenue Huntington Beach, CA 92647
		1	Monnante Research Corporation Mound Laboratory ATTN: Frank Neff Miamisburg, OH 45342

DISTRIBUTION LIST

<u>No. of Copies</u>	<u>Organization</u>	<u>No. of Copies</u>	<u>Organization</u>
1	Physics International 2700 Merced Street San Leandro, CA 94577	1	Ammann & Whitney ATTN: Mr. N. Dobbs Suite 1700 Two World Trade Center New York, NY 10048
1	R&D Associates ATTN: Mr. John Lewis P.O. Box 9695 Marina del Rey, CA 90291	1	Texas A&M University Department of Aerospace Engineering ATTN: Dr. James A. Stricklin College Station, TX 77843
1	Science Applications, Inc. 8th Floor 2361 Jefferson Davis Highway Arlington, VA 22202	1	University of Alabama ATTN: Dr. T.L. Cost P.O. Box 2908 University, AL 35486
1	Brown University Division of Engineering ATTN: Prof. R. Clifton Providence, RI 02912	1	University of Delaware Department of Mechanical and Aerospace Engineering ATTN: Prof J.R. Vinson Newark, DE 19711
1	Florida Atlantic University Dept. of Ocean Engineering ATTN: Prof. K.K. Stevens Boca Raton, FL 33432		
1	Georgia Institute of Tech ATTN: Dr. S. Atluri 225 North Avenue, NW Atlanta, GA 30332		<u>Aberdeen Proving Ground</u>
1	III Research Institute ATTN: Mrs. H. Napadensky 10 West 35 Street Chicago, IL 60616		Dir, USAMSA ATTN: DRXS-D DRXS-G, Mr. R. Norman DRXS-MP, H. Cohen
1	Massachusetts Institute of Technology Aeroelastic and Structures Research Laboratory ATTN: Dr. E.A. Witmar 77 Massachusetts Avenue Cambridge, MA 02139		Cdr, USATECOM ATTN: DRSTE-TO-F
3	Southwest Research Institute ATTN: Dr. H.N. Abramson Dr. W.E. Baker Dr. U.S. Lindholm 8500 Culebra Road San Antonio, TX 78228		Cdr, USATHAMA ATTN: DRXTH-TE
			Dir, USACSL ATTN: DRDAR-CLB-PA DRDAR-CLN DRDAR-CLJ-L

USER EVALUATION OF REPORT

Please take a few minutes to answer the questions below; tear out this sheet, fold as indicated, staple or tape closed, and place in the mail. Your comments will provide us with information for improving future reports.

1. BRL Report Number _____

2. Does this report satisfy a need? (Comment on purpose, related project, or other area of interest for which report will be used.)

3. How, specifically, is the report being used? (Information source, design data or procedure, management procedure, source of ideas, etc.) _____

4. Has the information in this report led to any quantitative savings as far as man-hours/contract dollars saved, operating costs avoided, efficiencies achieved, etc.? If so, please elaborate.

5. General Comments (Indicate what you think should be changed to make this report and future reports of this type more responsive to your needs, more usable, improve readability, etc.) _____

6. If you would like to be contacted by the personnel who prepared this report to raise specific questions or discuss the topic, please fill in the following information.

Name: _____

Telephone Number: _____

Organization Address: _____

FOLD HERE

Director
US Army Ballistic Research Laboratory
ATTN: DRSMC-BLA-S (A)
Aberdeen Proving Ground, MD 21005



NO POSTAGE
NECESSARY
IF MAILED
IN THE
UNITED STATES

OFFICIAL BUSINESS
PENALTY FOR PRIVATE USE, \$300

BUSINESS REPLY MAIL
FIRST CLASS PERMIT NO 12062 WASHINGTON, DC
POSTAGE WILL BE PAID BY DEPARTMENT OF THE ARMY

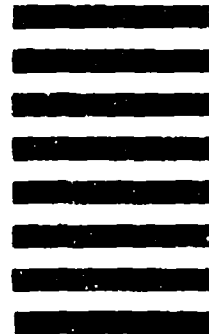

Director
US Army Ballistic Research Laboratory
ATTN: DRSMC-BLA-S (A)
Aberdeen Proving Ground, MD 21005

FOLD HERE