

AD-R138 030

ICE SHEET RETENTION STRUCTURES(U) COLD REGIONS RESEARCH 1/1  
AND ENGINEERING LAB HANOVER NH R E PERHAM DEC 83  
CREEL-83-30

UNCLASSIFIED

F/G 13/2 NL

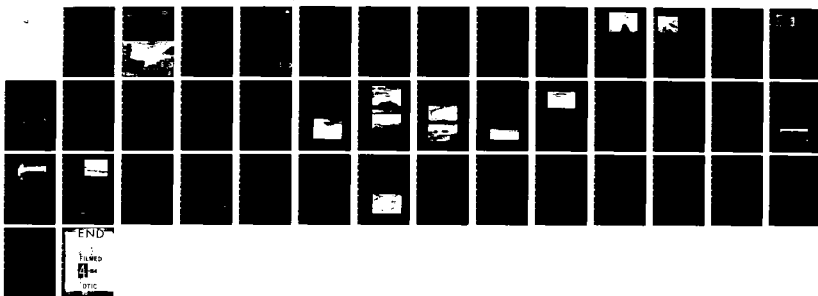

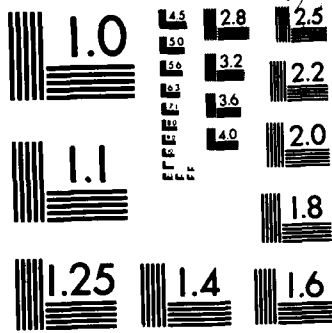

MICROCOPY RESOLUTION TEST CHART  
NATIONAL BUREAU OF STANDARDS-1963-A

# CRREL

REPORT 83-30

ADA138030

*Ice sheet retention structures*



US Army Corps  
of Engineers  
Cold Regions Research &  
Engineering Laboratory



*For conversion of SI metric units to U.S./British customary units of measurement consult ASTM Standard E380, Metric Practice Guide, published by the American Society for Testing and Materials, 1916 Race St., Philadelphia, Pa. 19103.*

ERRATA

CRREL Report 83-30

1. The photographs in Figure 9 have been transposed. The lower photograph shows the array of lines; the upper photograph shows the resulting ice cover.
2. The diagrams in Figure 18 have been transposed.
3. The dimensions of the fence boom are listed incorrectly in Table A1. The correct dimensions are 1.22 (height); 0.09 (gaps); 70% open.

*Cover: Ice booms on the St. Lawrence River above Galop Island near Ogdensburg, New York. Photograph courtesy of T. E. Falk, Ontario Hydro, Toronto.*



Unclassified

SECURITY CLASSIFICATION OF THIS PAGE (When Data Entered)

REPORT DOCUMENTATION PAGE		READ INSTRUCTIONS BEFORE COMPLETING FORM
1. REPORT NUMBER CRREL Report 83-30	2. GOVT ACCESSION NO. AD-A138 030	3. RECIPIENT'S CATALOG NUMBER
4. TITLE (and Subtitle) ICE SHEET RETENTION STRUCTURES		5. TYPE OF REPORT & PERIOD COVERED
		6. PERFORMING ORG. REPORT NUMBER
7. AUTHOR(s) Roscoe E. Perham		8. CONTRACT OR GRANT NUMBER(s)
9. PERFORMING ORGANIZATION NAME AND ADDRESS U.S. Army Cold Regions Research and Engineering Laboratory Hanover, New Hampshire 03755		10. PROGRAM ELEMENT, PROJECT, TASK AREA & WORK UNIT NUMBERS CWIS 31725
11. CONTROLLING OFFICE NAME AND ADDRESS Office of the Chief of Engineers Washington, D.C. 20314		12. REPORT DATE December 1983
		13. NUMBER OF PAGES 39
14. MONITORING AGENCY NAME & ADDRESS (if different from Controlling Office)		15. SECURITY CLASS. (of this report) Unclassified
		15a. DECLASSIFICATION/DOWNGRADING SCHEDULE
16. DISTRIBUTION STATEMENT (of this Report)  Approved for public release; distribution unlimited.		
17. DISTRIBUTION STATEMENT (of the abstract entered in Block 20, if different from Report)		
18. SUPPLEMENTARY NOTES		
19. KEY WORDS (Continue on reverse side if necessary and identify by block number) Ice control structures Ice sheets Ice sheet retention		
20. ABSTRACT (Continue on reverse side if necessary and identify by block number) Ice sheets are formed and retained in several ways in nature, and an understanding of these factors is needed before most structures can be successfully applied. Many ice sheet retention structures float and are somewhat flexible; others are fixed and rigid or semirigid. An example of the former is the Lake Erie ice boom and of the latter, the Montreal ice control structure. Ice sheet retention technology is changing. The use of timber cribs is gradually but not totally giving way to sheet steel pilings and concrete cells. New structures and applications are being tried but with caution. Ice-hydraulic analyses are helpful in predicting the effects of structures and channel modifications on ice cover formation and retention. Often, varying the flow rate in a particular system at the proper time will make the difference between whether a structure will or will not retain ice. The structure, however, invariably adds reliability to the sheet ice retention process.		

## **PREFACE**

This report was prepared by Roscoe E. Perham, Mechanical Engineer, Ice Engineering Research Branch, Experimental Engineering Division, U.S. Army Cold Regions Research and Engineering Laboratory. It was funded under CWIS 31725, *Sheet Ice Retention Structures*. It was technically reviewed by James Wuebben and Darryl Calkins of CRREL.

The contents of this report are not to be used for advertising or promotional purposes. Citation of brand names does not constitute an official endorsement or approval of the use of such commercial products.

## CONTENTS

	Page
Abstract .....	i
Preface .....	ii
Introduction .....	1
Natural ice sheets .....	1
Choosing an ice control structure .....	3
Flexible structures .....	4
Ice booms .....	4
Frazil collector lines .....	12
Fence booms .....	13
Rigid or semirigid structures .....	14
Pier-mounted booms .....	14
Stone groins .....	15
Artificial islands .....	17
Removable gravity structures .....	19
Timber cribs .....	19
Weirs .....	20
Pilings and dolphins .....	22
Structures built for other purposes .....	22
Hydroelectric dams .....	22
Wicket dams .....	23
Light piers and towers .....	23
Bridge piers .....	25
Breakwaters .....	25
Ice control not using structures .....	26
Channel improvements .....	26
Ice sheet tying .....	26
Ice sheet bridges .....	26
Conclusions .....	27
Literature cited.....	27
Appendix A: Ice control structures .....	30

## ILLUSTRATIONS

Figure	
1. Aerial view of early winter river ice in the Niagara River .....	2
2. Aerial view of an ice cover beginning to arch across the Ohio River at New Richmond, Ohio .....	3
3. Typical ice boom arrangement .....	5
4. Cross sections of ice boom timbers and pontoons .....	6
5. Typical ice boom anchors .....	8
6. Plan view of the Lake St. Francis ice boom built in 1981 .....	10
7. Plan view of the Allegheny River ice boom built in 1982 .....	11
8. Synthetic fiber rope ice boom .....	11
9. Frazil collector lines .....	12

Figure	Page
10. Fence boom across the Mascoma River, New Hampshire .....	13
11. Pool formed by the action of frazil ice on a fence boom .....	13
12. Montreal ice control structure .....	14
13. Fixed ice boom at Sigalda Reservoir, Tungnaa River, Iceland .....	15
14. Inlet structure at Hrauneyjafoss Power Canal, Tungnaa River, Iceland .....	15
15. Ice control groins on the Burntwood River, Manitoba, Canada .....	16
16. Ice control groins and booms on the Pasvik River, Hestefoss, Norway .....	16
17. General plan and location of artificial islands, ice booms and light piers in Lake St. Peter.....	17
18. Cross sections of artificial islands in Lake St. Peter .....	18
19. Ice-anchoring islands in Lake St. Louis, St. Lawrence River, near Chateauguay, Canada .....	18
20. Rock-filled scow stabilizing the ice cover in Soo Harbor, Michigan .....	19
21. Ice-holding timber cribs in the Narragaugus River, Maine .....	20
22. Stone-filled timber cribs and concrete caps used as light tower bases .....	20
23. Timber weir .....	21
24. Two-meter-high ice control weir on the Israel River, New Hampshire .....	21
25. Stone weir used with experimental ice boom, Chaudiere River, Quebec .....	21
26. Weir and stationary grating on the Chaudiere River, Quebec .....	22
27. Typical section of a navigable pass portion of a wicket dam, Ohio River Lock and Dam No. 10, Steubenville, Ohio .....	23
28. Light pier built in 1968 on Lake St. Peter, Canada .....	24
29. Light no. 14 on Lake St. Clair, Michigan .....	24
30. Steel light tower on Maumee Bay, Lake Erie .....	25
31. Ice sheet retention by tying with lines, Mississippi River, Prairie du Chien, Wisconsin, 1981 .....	26

# ICE SHEET RETENTION STRUCTURES

Roscoe E. Perham

## INTRODUCTION

During the winter in northern areas, ice usually covers the lakes, rivers and streams. In the rivers and streams the ice cover is often initiated by smaller particles called frazil, which can develop into masses of slush and anchor ice. Frazil ice adheres to the screens and grates of water intakes and severely restricts or completely blocks their inflow. Municipal and industrial water supplies are affected, and a few hydroelectric plants have even been shut down by frazil ice blockages. Frazil does not form when the water body has an ice cover. Consequently, if a stable ice cover can form and be maintained, these blockages can be avoided. The use of navigable waterways in winter can also be economically beneficial if the ice cover can be stabilized.

The purpose of this report is to describe the structures and techniques that are used to help ice covers form and persist throughout the winter. Structures built for this purpose may be flexible or rigid. Some structures may be built for other purposes but may also help in forming or retaining ice covers. Some techniques of ice control don't involve structures at all. This report gives examples of each device and method; complete information needed for detailed designs is available in the cited references.

## NATURAL ICE SHEETS

To understand how structures can be used to control ice, one needs to understand the principles that

govern ice cover formation and maintenance in nature. The physical phenomena involved have been described in detail by Pariset and Hausser (1961), Devik (1964) and Ashton (1980).

At the onset of winter, heat is lost from water bodies to the atmosphere through natural and forced (wind) convection, evaporation and radiational cooling (Dingman et al. 1967). For most engineering purposes the net heat transfer can be approximated by the product of a constant coefficient and the mean temperature difference between the water and atmospheric temperatures. Studies of natural cooling of the St. Lawrence River found a mean value of  $22.5 \text{ W/m}^2$  for thermal conductance from the water surface (McLachlan 1927). Before an ice cover can form, the water on the surface must cool to the freezing point. After an ice cover forms, the heat of fusion (from ice growth) must pass through a layer of ice before reaching the surface, so the rate of heat transfer is reduced. Snow on top of the ice is effective thermal insulation, and it can reduce ice growth dramatically.

Because water is densest at  $4^\circ\text{C}$ , colder water in lakes tends to stratify above warmer water. The ice cover can form while much of the lake contains relatively warm water. Wind can increase the cooling rate, but it can also mix the water to a greater depth so that much more of the lake water is affected. Besides atmospheric temperatures the time of freezeup and the completeness of the ice cover are affected by the size of the lake, the amount of water flowing through it, and the wind conditions. Some very large lakes, such as the Great Lakes, almost never freeze over completely. One consequence of this is the presence of large,



*Figure 1. Aerial view (looking downstream) of early winter river ice in the Niagara River below the South Grand Island Bridge. The river is approximately 520 m wide at this location, which is about 15 km downstream from the Lake Erie ice cover. Except for the whitest ice floes with clearly defined edges, the ice floes developed solely within this reach. Individual floes, masses of floes, and partly solidified masses can be seen. The masses near the left shore may have received some snow-fall; many of them exhibit the smoother edges that usually come from rubbing against border ice.*

ratted ice floes, which are moved about by the wind and have a high potential for damaging structures.

The water in most rivers and streams is in the turbulent flow regime and is continually mixing from the surface to the bottom of the river, so the tendency for stratification is overcome. Conditions are isothermal at all depths. Border ice along the banks indicates that an ice cover is trying to form but the current is swift enough to remove the ice crystals growing at the ice/water interface.

After the main bulk of the water has cooled nearly to its freezing point, it can lose heat quickly enough on a clear, cold night to become supercooled by a small fraction of a degree (Schaefer 1950, Granbois 1953, Devik 1964, Michel 1971). Frazil appears in the water and grows rapidly. By heat exchange, supercooled water lowers the surface temperature of submerged solids such as rocks, roots and metal objects to the freezing point and below. The ice particles adhere to these solids as well as to each other. In this way underwater ice accumulations get their start on the streambeds and water intakes. As water changes to ice, it gives up its latent heat of fusion (333 kJ/kg; 144 Btu/lb) to the surrounding water, and the supercooled state for part of the flow is dissipated. The free-moving ice particles usually grow as disks and

platelets and agglomerate into clumps of frazil slush, gaining sufficient buoyancy to rise to the surface. Here they develop into ice pans and ice floes, which move with the water currents (Fig. 1).

The formation of an ice cover on a river from these ice floes is described by Pariset and Hausser (1961). In reaches where the mean velocity is low (0.15–0.3 m/s), an ice cover will grow from the banks out across the river as it does in a small lake, mainly by the horizontal propagation of ice crystals. If the mean stream velocity on the river is 0.38 m/s or higher (McLachlan 1927), the ice cover forms instead by the accumulation of the ice floes against a downstream ice cover or other obstruction. If the ice floes formed by frazil masses are numerous and the water velocity is not too great, the floes will jam mechanically in a neck or narrows of the river and form a stable ice arch (Fig. 2).

The upstream edge of an unconsolidated ice cover will proceed upstream until it comes to a river reach where the velocity is about 0.69 m/s or greater. Here the hydrodynamic forces at the ice edge begin to cause floes to be drawn under. Larger floes are generally more resistant to these forces. This phenomenon, one of the most important factors in ice control, has been investigated by Latyshenko (1946), Pariset and Hausser (1961), Uzunur and Kennedy (1972)



*Figure 2. Aerial view (looking downstream) of an ice cover beginning to arch across the Ohio River at New Richmond, Ohio. The ice transport capacity of the river is being reduced by border ice growing along the inside of the bend and ice restrained on the outside of the bend by several spurlike protrusions. The open water means that the downstream ice passed through the narrows; the ice immediately upstream has wedged in the narrows like a keystone.*

and Ashton (1974). Theoretical considerations suggest that the Froude number  $Fr$  at the ice edge is a criterion for whether or not the floes are drawn under. Evaluating field observations for several Canadian rivers, Kivisild (1959) found this to be borne out at an average value of

$$Fr = \frac{V}{\sqrt{gh}} = 0.08$$

where  $V$  = mean stream velocity  
 $h$  = water depth at the ice edge  
 $g$  = gravitational acceleration.

Other criteria for the stability of the unconsolidated ice cover consider the width of the river and the thickening of the ice cover by ice shove and pileup of ice floes. These are given also by Pariset and Hausser (1961) and Pariset et al. (1966).

Any open water upstream not caused by thermal effluents can continue to generate frazil ice, which will be drawn under the ice cover and deposited there. These deposits can cause a hanging dam to develop, restricting the flow capacity of the river. Unless the open water area can be made small enough for the frazil developed there to be readily assimilated by downstream portions of the waterway, it will be a continual source of trouble.

Ice covers generally form quickly and easily on lakes, but ice problems can be found there, too. A cold wind blowing over an open lake can generate frazil ice that, for instance, has clogged water intakes 7.5 m or more deep (Devik 1964, Foulds 1974). Even after an ice cover has grown thick enough to walk on,

strong winds can break it up through wave action and seiches. Under certain conditions, if water is drawn from a lake through a power canal, ice floes can be drawn into submerged intakes by flow currents (Stewart and Ashton 1978). After solid ice becomes 0.3 m or greater in thickness, its chances of breakup by wind are generally small.

A river ice cover is normally retained by the shoreline and protruding rocks or islands. Submerged rocks on which anchor ice grew when the cover formed can restrain ice in shallow rivers also. When the river water level drops, the ice cover usually does not move downstream, because the ice remains in contact with the shore through jagged hinge cracks and shoreline irregularities. When the water level rises, however, the ice sheet usually breaks completely free from the grounded border ice. The current drags the ice cover; wind drag can be quite large when the ice sheet is large. The cover will move downstream unless it remains engaged to gross shoreline irregularities, islands, rocks or well-rooted trees leaning into the water (and into the ice). Bends in the river can also prevent long, straight ice sheets from passing.

### CHOOSING AN ICE CONTROL STRUCTURE

Ice control structures often simulate natural processes. Many characteristics of the water body must be considered in choosing a suitable ice control structure.

Hydraulic flows in rivers and streams can be analyzed by computer, and programs that consider flows

in the presence of ice, such as the HEC-2 program for ice-covered waterways (Calkins et al. 1982), are now available. This program can be very helpful in locating and sizing an ice control structure and predicting its performance. Upstream and downstream channel modifications can be studied as well.

The relationships by Pariset and Hausser (1961) and Pariset et al. (1966) for the formation of ice covers are very useful in designing ice control structures. They were used to guide engineers designing the Churchill Falls hydroelectric project in an area noted for frazil ice and ice jams (Atkinson and Waters 1978). The most important factor for this project was reliability in maintaining winter flows; reservoir dike height and channel size were strong economic factors. A two-level forebay with a gated control structure between the levels was selected, and an ice boom was located upstream of the structure. It was calculated that the frazil ice forming in open water upstream could be contained behind the ice in the forebay. Three winters' operation of the project, two of which were at full or high flows, were highly successful, indicating that the design criteria were somewhat conservative.

Most ice control structures, such as ice booms, simulate the upstream edge of an existing ice cover. That is, the ice floes floating on the surface and moving downstream with the water currents collect against a floating barrier and are held against it by the water flow. The water continues along beneath the barrier unimpeded. Where the water velocities are too high, ice floes are drawn under the ice edge by hydrodynamic effects, and the flow velocity must be reduced. The channel could be widened or deepened, a weir or sill could be installed downstream to deepen the river, or the flow rate could be reduced by a flow control dam. Flow control dams are more efficient downstream of the site because the reduced flow is accompanied by a water level increase. An upstream control, however, causes the water to become shallower at the site, which tends to counteract the benefit of reduced velocities. After an ice cover has formed and solidified, it can usually withstand the forces and effects of a return to the higher flows.

In some locations (mainly reservoirs) the water level can be held fairly constant, but water must sometimes be spilled. If ice followed it over the spillway, the discharge would almost certainly create an ice jam. At such a location a fixed boom could be used.

Structures like artificial islands, light towers, groins and timber cribs function like islands or boulders. Artificial islands are generally armored with large stones to resist the impact and abrasion of moving ice. Most stationary structures, however, have a layer of ice that develops at the water line and protects them against this damage.

The thermal expansion of ice can affect these structures. Like other solids, solid ice shrinks as it cools and expands as it warms. Ice that has remained cold for a considerable period of time and then undergoes rapid warming can apply substantial pressure to ice control structures that have little or no compliance. For example, an ice sheet between a concrete light tower and the shore can expand to apply heavy lateral loads to the tower.

Structures on lakes can also receive impact loads from ice floes. Because wind and wave action can cause ice to raft upon itself, a moving floe can be several layers thick. A tower without a protective riprap skirt to dissipate the kinetic energy of the ice can be in serious trouble.

## FLEXIBLE STRUCTURES

Flexible cable or wire rope structures are used to hold floating ice barriers in place. The structures themselves are compliant but strong, and their ability to stretch or flex in response to the impact of moving ice sheets has prevented failure (Perham 1977). The thermal expansion of ice, which is of greatest concern in rigid structures such as dams (American Society of Civil Engineers and United States Committee on Large Dams 1967), has a negligible effect on flexible structures.

They are used on generally accessible bodies of water where one must control ice in winter while permitting unrestricted water use during the warm months. The ice cover they help form and stabilize protects water intakes and navigation channels against excessive ice encroachment.

The most important advantages of flexible structures are: 1) the main structural components usually have a negligible effect on water flows; 2) the structures (except for buried anchors) are readily installed prior to the ice season and removed afterward; 3) the structures can withstand the passing of ice breakups; 4) a variety of standardized components are available for a wide range of loads; and 5) the structures can be worked on using common maritime equipment, such as barges, cranes, winches and tugs.

## Ice booms

Ice booms are the most widely used type of sheet ice retention structure. The first such structures were long booms of logs chained or wired end to end into a long line across a water body. The logs provided flotation as well as structural strength. Sometimes several logs were bolted side by side to obtain sufficient flotation. The booms were anchored onshore and to boom docks (rock-filled timber cribs) in mid-stream. The trash booms used at hydroelectric plants

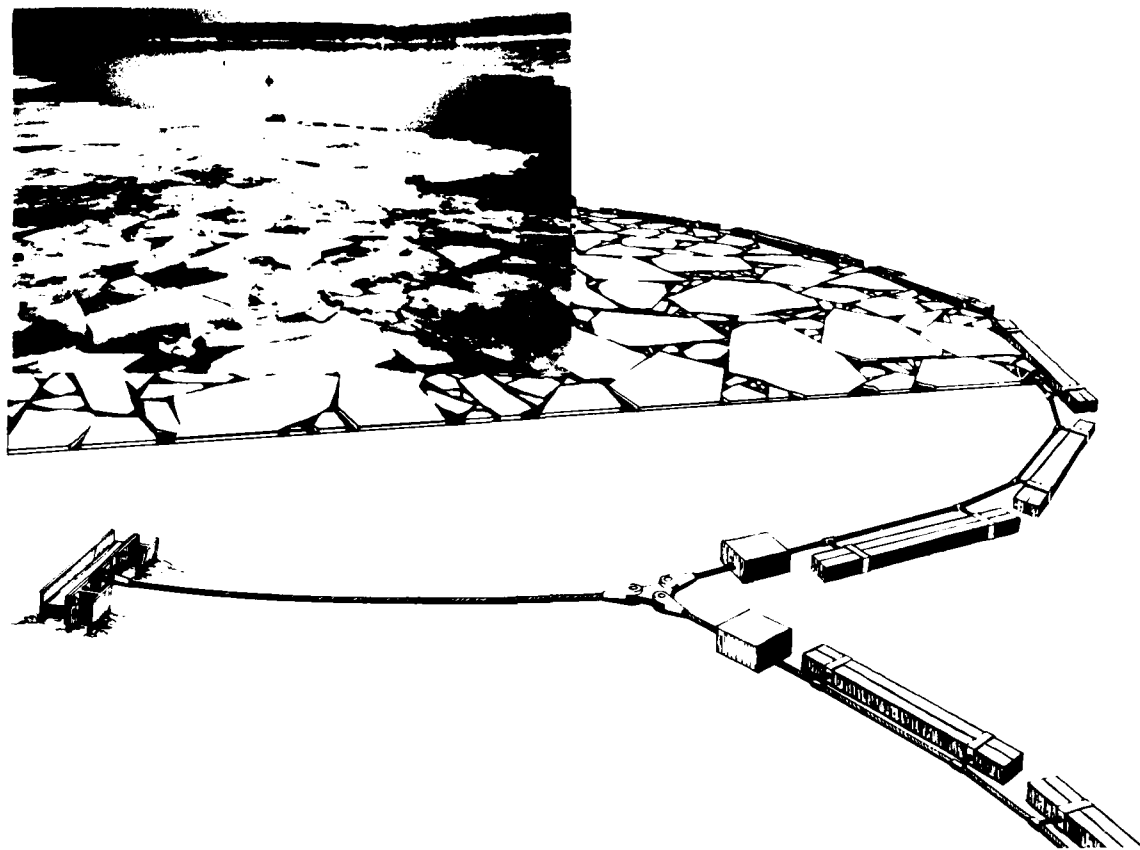

Figure 3. Typical ice boom arrangement.

to keep floating debris from power canals are similar and may have been the first to use a continuous wire rope for structural strength.

The most common type of ice boom consists of large floating timbers held in place by a wire rope structure and buried anchors (Fig. 3). The weight of the wire rope structure and junction plates is carried by supplemental floats.

#### Function

Boom structures can be installed across a portion of a river or across the entire width, according to the amount of control needed. The floating timbers intercept moving ice floes, frazil slush and brash ice to form an unconsolidated ice cover upstream of the boom. Within 10 days the ice cover usually becomes consolidated. To be effective, an ice boom must restrain an ice cover at the surface without restricting water flow, and it must move up and down with the ice cover.

An unconsolidated ice cover develops most rapidly when the water velocity (bringing ice floes to the boom) is as large as possible without causing appreciable quantities of ice to pass beneath the boom. Carter (1959) determined from field tests that this

velocity for a straight, 3-m-deep channel was 0.46 m/s. This value is also optimum for the deeper but somewhat irregular Beauharnois Canal; the smooth ice cover that develops there allows efficient power generation in winter (Perham and Radiot 1975, Perham 1976). In several major installations the mean velocities vary from 0.29 to 0.75 m/s (Bryce and Berry 1967).

#### Boom components

Although ice booms vary in function and appearance, their wire rope structures are similar. The wire ropes to which the timbers or pontoons are connected are somewhat longer than the spacing between the anchors, giving a boom its scalloped appearance. In existing booms these lateral ropes are longer than the span by values ranging from 6 to 25%; the greater length lowers the tension in the lateral rope.

Individual wire ropes are connected by steel junction plates that are supported by buoys or floats. Galvanized wire ropes are often used for longer life, although the strength of the galvanized wire is 10% less than that of uncoated wire when new.

Figure 4 shows a variety of ice boom designs. De-

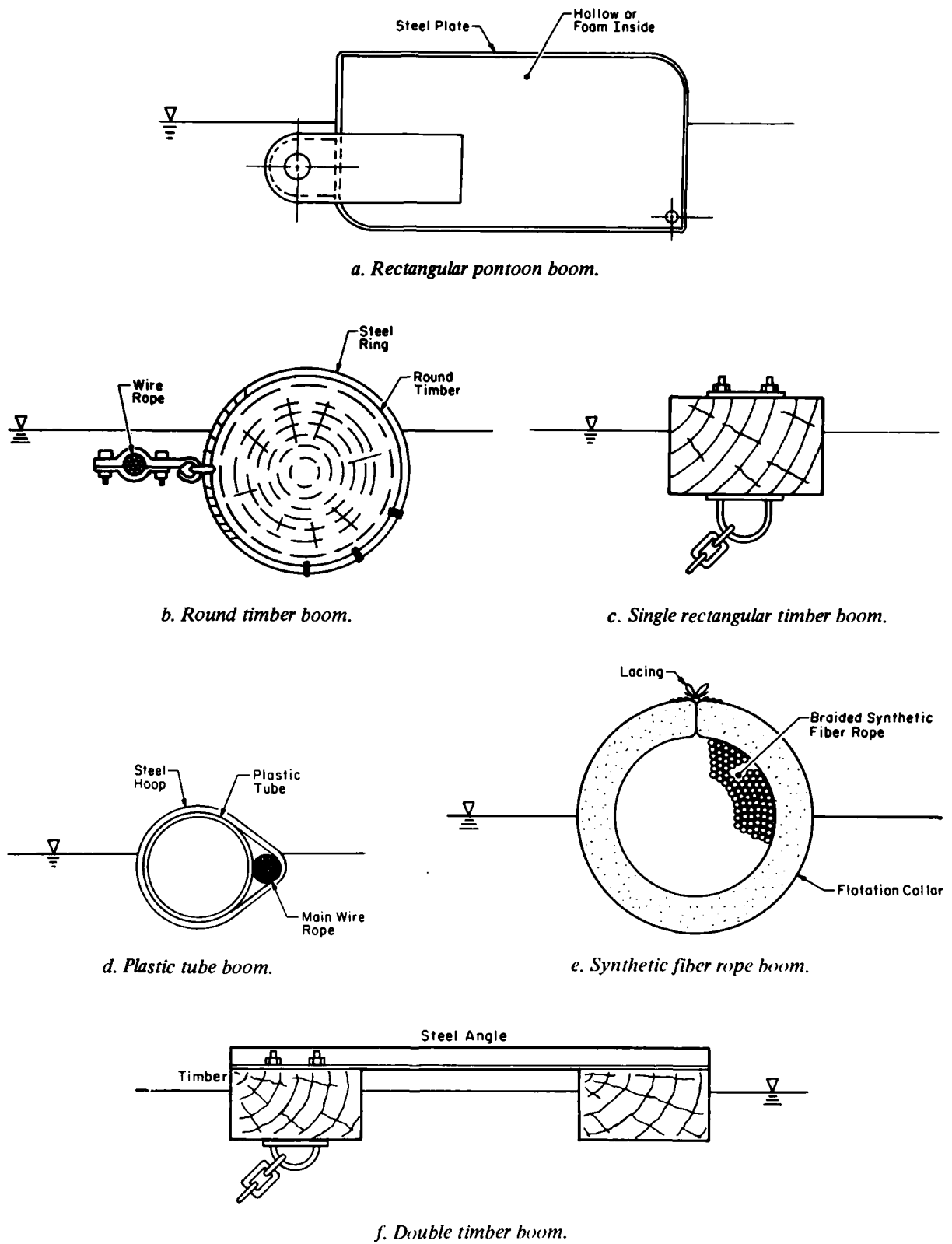
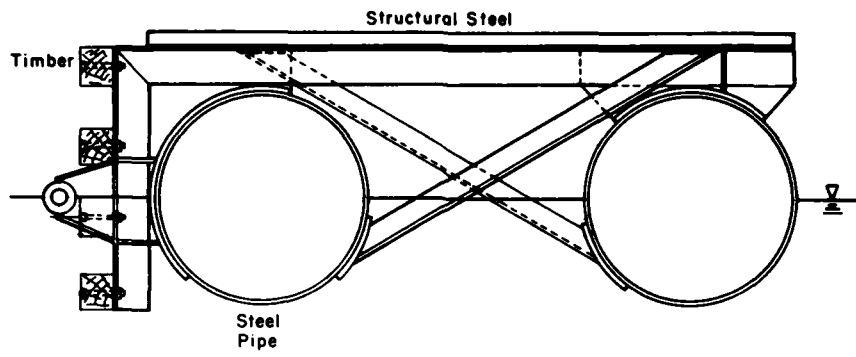
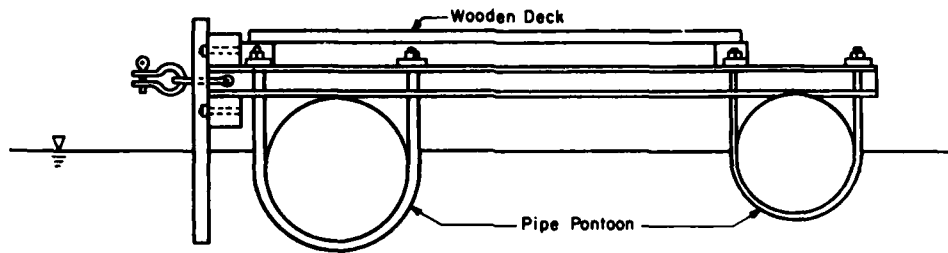

Figure 4. Cross sections of ice boom timbers and pontoons.



*g. Double steel pontoon boom.*



*h. Shear boom.*

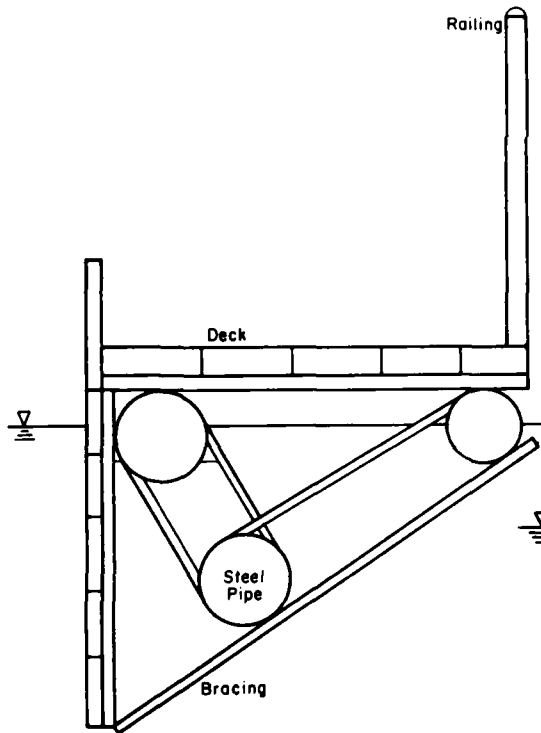

*i. Shear boom.*

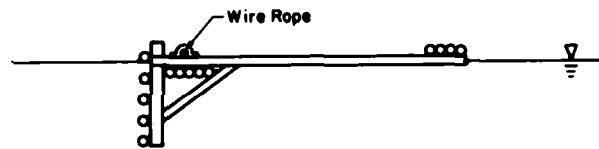

*j. Wooden pole boom.*

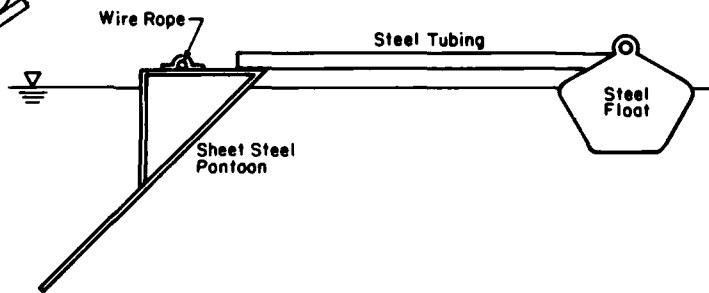

*k. Triangular-skirted pontoon boom.*

*Figure 4 (cont'd).*

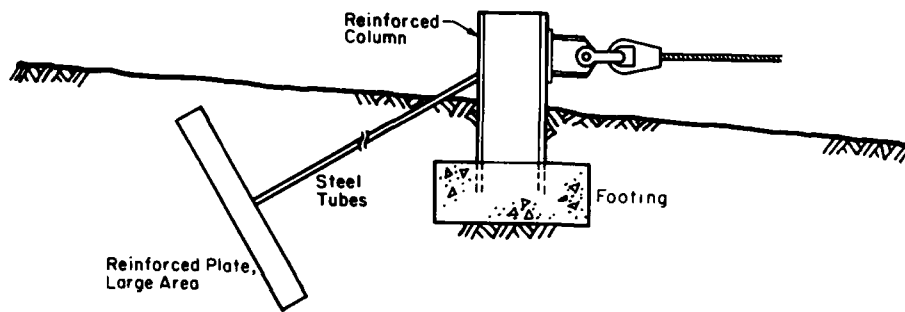

*a. Deadman and pedestal (end, land).*

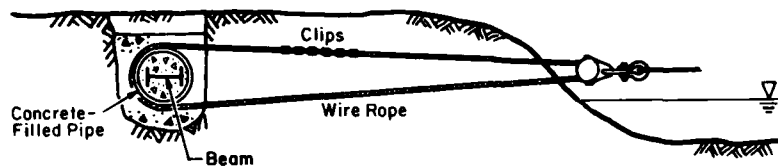

*b. Deadman and wire rope (end, land).*

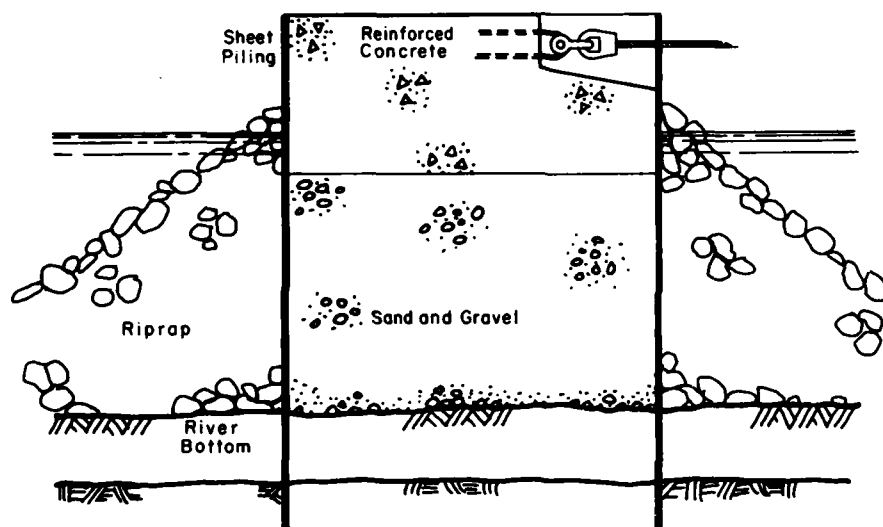

*c. Sheet piling cell (end, in water).*

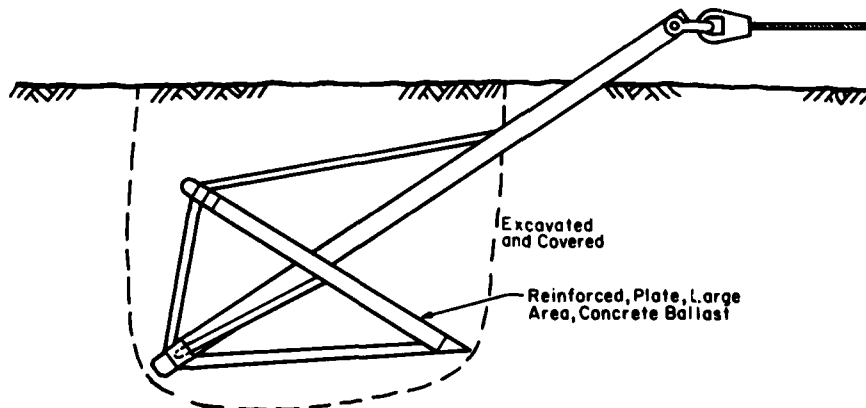

*d. Steel anchor (midpoint, in water).*

*Figure 5. Typical ice boom anchors.*

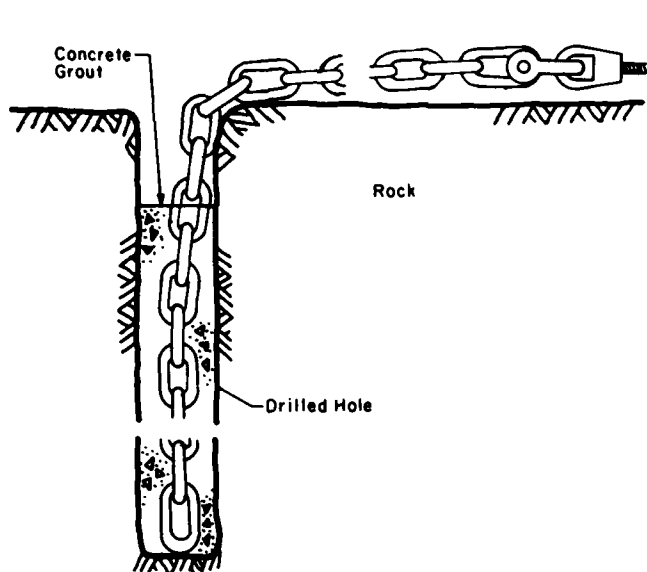

e. Grouted chain (midpoint, in water).

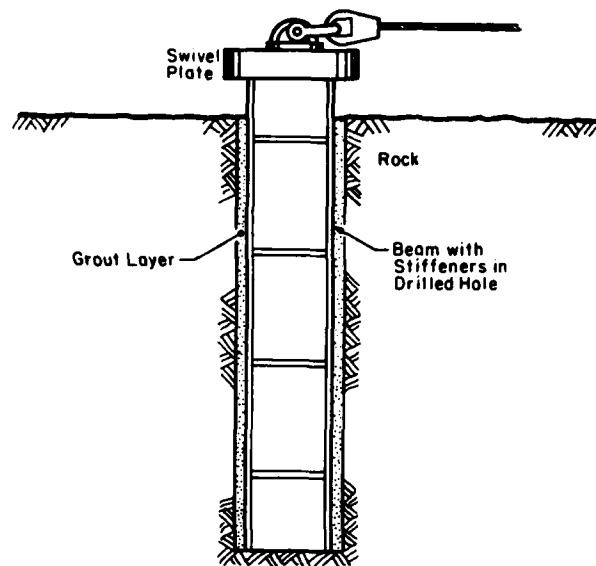

f. Grouted weldment (midpoint, in water).

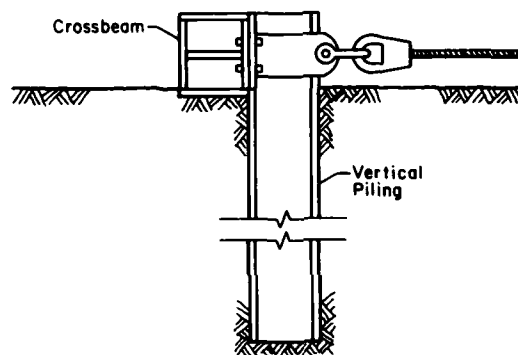

g. Piling and crossbeam (end, midpoint, land, in water).

Figure 5 (cont'd).

signs h, i and k have been used as shear booms for waterborne trash and logs; the floating material is expected to slide along the upstream face of the boom. The proper combination of buoyancy and stability can be determined through tests and analysis (Perham 1978). Wooden timbers can lose effectiveness by becoming water-logged (Perham 1974).

Anchor types may vary on any one boom and from one boom to the next. They use the strength of the riverbed and bank materials. A structure that reaches from shore to shore will have anchors onshore and sometimes along the river bottom. The anchor lines from the river bottom to the floating parts are generally about 12 times longer than the water depth. Typical anchors are shown in Figure 5. The cell structure is sometimes used at the midstream end of a spur boom, which reaches only partway across a river.

#### Forces on booms

The forces on the ice boom  $f_i$  come from several sources: the drag of water flowing beneath the ice  $f_w$ , the drag of wind blowing over the ice  $f_a$ , the momentum change of water diverted by the upstream ice edge  $f_p$ , the momentum of ice floes accumulating at the ice edge  $f_m$ , the downstream component of the weight of the ice cover  $f_g$ , and the combined friction, cohesion and material shearing drag at the shoreline  $f_s$ , which opposes the others. That is

$$f_i = f_w + f_a + f_p + f_m + f_g - f_s.$$

The dominant forces are  $f_w$ ,  $f_a$ , and  $f_s$ ;  $f_s$  is usually large enough to support the ice cover without the aid of the boom after the unconsolidated ice cover is three to four times as long as it is wide. Pariset and

Hausser (1961) and Michel (1966) give excellent guidance in estimating boom forces. Before using this information to design a boom, one should obtain water velocity data for the expected range of discharges and long-term wind data for the site. Also, one should determine if thermal effluents or ship effects will disturb the ice cover upstream of the boom; a resulting open water lead could allow the ice sheet to rotate, which could increase ice loading on certain parts of an ice boom.

*Examples of flexible booms*

A representative list of flexible ice booms is given in Appendix A. The largest boom to be installed in recent times is in Lake St. Francis upstream of the Beauharnois Canal in Canada (Fig. 6). It was designed to accommodate ship navigation and was extensively tested as a model (Boulanger et al. 1975).

A boom of similar construction was built in 1982 on the Allegheny River upstream of its confluence with Oil Creek at Oil City, Pennsylvania (Fig. 7) (Deck and Perham 1981). Oil City has a long history of ice jams and floods. Deck and Gooch (1981) discovered large deposits of frazil ice downstream of the confluence in a deep section of the river. The accumulations especially restrict flows from ice breakup on Oil Creek, which precedes ice breakup on the Allegheny River.

The ice cover upstream of the boom should stabilize in early winter and eliminate the primary source of frazil ice.

The Lake Erie ice boom, located at the head of the Niagara River at the east end of Lake Erie, is especially effective. The boom increases the strength and reliability of the ice arch that forms there every winter. The hydroelectric plants downstream have almost no control over the flow at that location. The boom is highly cost-effective in improving the reliability of electrical production (Perham 1976).

An experimental boom for the Chaudiere River in Quebec, Canada, is described by Llamas (1965). The boom was like a horizontal rope ladder with steel structural channel sections for rungs. The spaces between the rungs were filled with wooden blocks. The two parallel 25-mm-diameter wire ropes were anchored to heavy concrete structures at each shore. The arrangement was expected to retain ice until a flow of 207 m<sup>3</sup>/s (four-year flood) was reached.

The test boom at the Montreal ice control structure uses a synthetic fiber rope (Fig. 8). The 0.18-m-diameter braided rope was made from nylon and polypropylene plastic and has 10 supplemental flotation sleeves spaced along its length (Morrison 1972). The water velocities varied from 0.61 to 0.76 m/s.

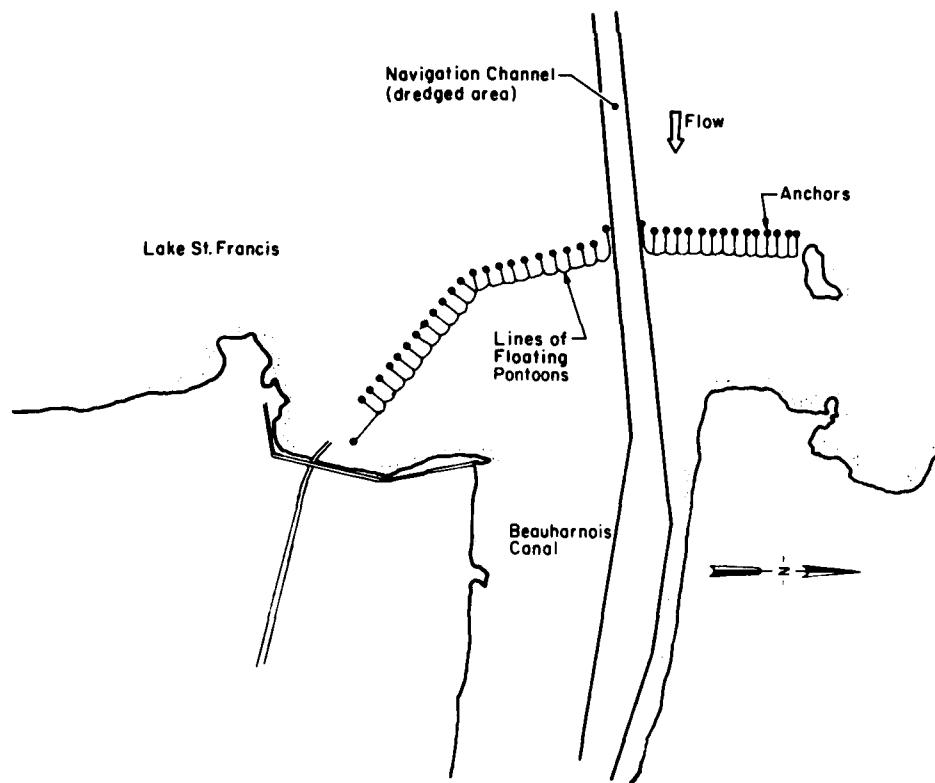

Figure 6. Plan view of the Lake St. Francis ice boom built in 1981.

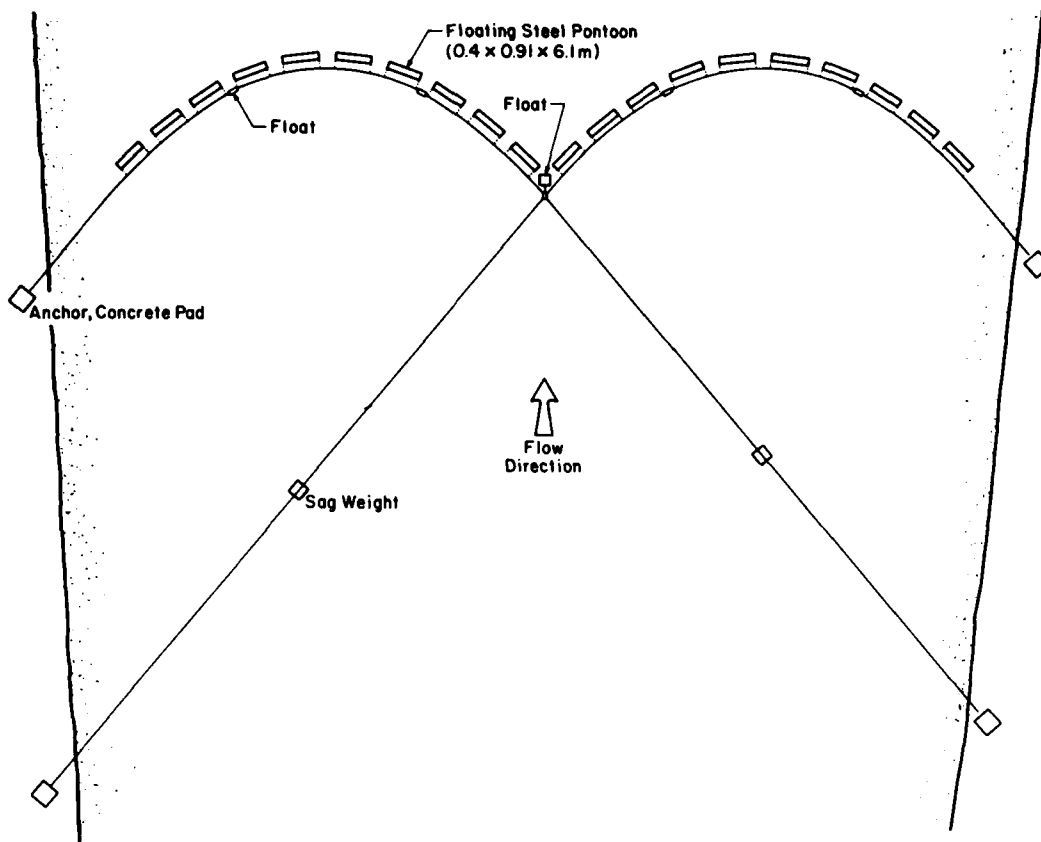

Figure 7. Plan view of the Allegheny River ice boom built in 1982.



Figure 8. Synthetic fiber rope ice boom.



*a. Array of lines (4.9x15.2 m).*



*b. Resulting ice cover.*

*Figure 9. Frazil collector lines.*

#### **Frazil collector lines**

Frazil collector lines, which are still experimental, are arrays of lines made from nylon, polypropylene, polyester or wire rope (Perham 1981). An array is anchored in a stream, and active frazil ice freezes to each line (Fig. 9a). Overnight accumulations 10 to 12 cm in diameter on each line are common. As the lines

and frazil ice float on the stream's surface, the entrapped interstitial water is practically stationary and freezes quickly to form an ice cover over the entire line array (Fig. 9b); even 6- and 8-mm-diameter wire ropes are buoyed up by the frazil ice accumulations.

It seems feasible to cover a troublesome open water reach of a canal or stream with one or several sets of

steel or synthetic fiber lines. The ideal combination of unit length and frequency of units needed to prohibit further supercooling has not been determined. If the lines are naturally buoyant, a set can be anchored where they will freeze into the ice sheet without being buoyed by frazil ice; they would then become a reinforcement and a means for supplemental restraint.

#### **Fence booms**

A fence boom is an experimental structure supported across a stream by steel cables and resting on the streambed (Fig. 10). The fence boom has little effect on stream flow before icing conditions start. Its appearance is that of a slatted snow fence or a wooden grate. It is stable when connected to single anchor points buried in each bank because of the curved

shape it takes in response to the hydrodynamic and static water pressures acting on it.

Active frazil generated in the stream attaches to the vertical bars and eventually fills in the spaces between the bars from the streambed to the surface. Water flows continuously, so the frazil ice blockage causes the water level upstream of the boom to rise and overflow the blockage. This, in turn, increases the elevation of the region that can be blocked by frazil ice. Eventually a pool is created upstream, with water flowing over the top of the fence boom (Fig. 11). An ice cover develops and progresses upstream until a surface flow velocity of 0.69 m/s is reached.

Field tests showed that the boom works well, but it has been tested in only one mountain stream. A problem developed where the streambed eroded beneath part of the boom; armoring may be needed beneath the boom.

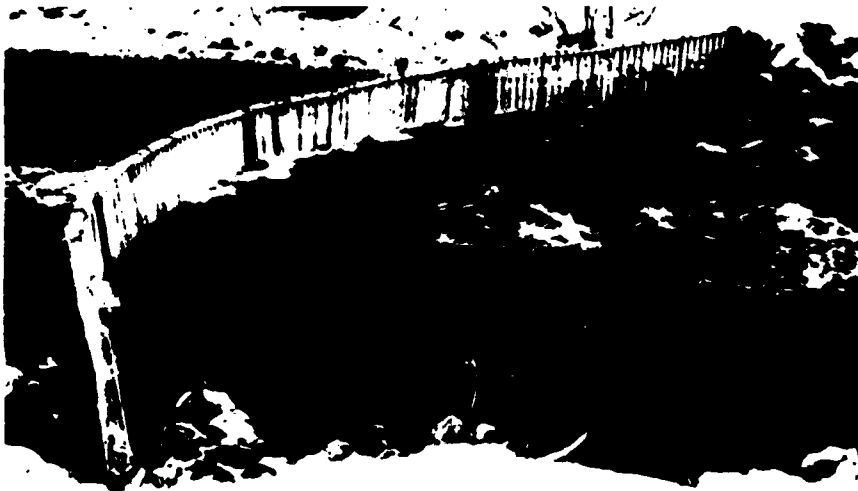

*Figure 10. Fence boom (1.2 m high) across the Mascoma River, N.H.*



*Figure 11. Pool formed by the action of frazil ice on a fence boom.*

## RIGID OR SEMIRIGID STRUCTURES

Rigid or semirigid structures may or may not have moving parts. They are appreciably more rigid than a typical ice boom, but their deflection in response to the horizontal push of an ice sheet is on the same order as the deflections that develop in the ice sheet.

Because these structures are generally unyielding, they are particularly susceptible to ice sheet impact and thermal expansion loads. The state of the art in design today is generally based on the conservative values of load and stress developed for dams and bridges (Carstens 1980).

### Pier-mounted booms

#### *Floating booms*

The Montreal ice control structure (Fig. 12) was built primarily to compensate for the ice conditions caused by the narrowing of the St. Lawrence River due to construction of the Expo '67 world's fair. The structure, which is permanent, uses floating steel booms or stop logs set between concrete piers to collect ice floes and help stabilize an ice cover earlier in winter than would normally be the case. The booms are kept free to move vertically in guide slots in the piers by radiant electric heat. The 2.04-km-long structure cost approximately \$18 million in 1964-65. Pariset et al. (1966) described the hydrotechnical aspects of the design, and Stothart and Croteau (1965) and Lawrie (1972) described many physical characteristics of the structure.

The operating levels for the booms were determined by model studies and analysis of the backwater effects due to the formation of the ice cover downstream in Montreal Harbor and below. At these levels the large quantities of ice expected from the Lachine Rapids upstream can be stored beneath the ice cover.

The structure was designed using dam technology to provide high structural integrity. The booms float, but they are not allowed to turn over as they might do with a flexible rope structure. In spite of their strength they are susceptible to damage by the concentrated impact loads of moving ice sheets. Also, the operation of the structure is affected by the same hydraulic factors as the other booms.

#### *Fixed booms*

Reinforced concrete beams of great depth are used at some reservoirs to restrain ice while water is being discharged over a spillway or into a canal. The spillway barrier shown in Figure 13 is located on the Sigalda power project reservoir on the Tungnaa River in Iceland, about 165 km east of Reykjavik. The space below it provides 5 m of clearance. Ice is held on the reservoir under all but the most severe flood conditions.

Five kilometers downstream of Sigalda a boom protects the entrance to the power canal of the Hraunyjafoss power project. During periods of frazil ice generation the frazil agglomerations collect at the reinforced concrete boom (Fig. 14). The structure functions as a shear wall when a portion of the river flow is used to sluice the frazil over an adjacent, gated sluiceway. Model studies showed that the deep, fixed boom

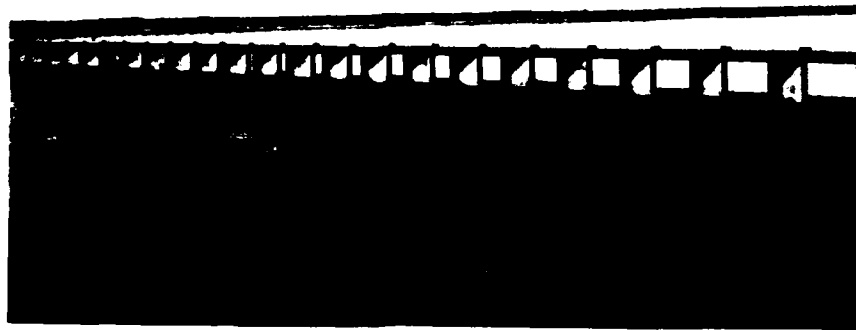

Figure 12. Montreal ice control structure (looking southwest and upstream). The LaPrairie Basin is in the background.

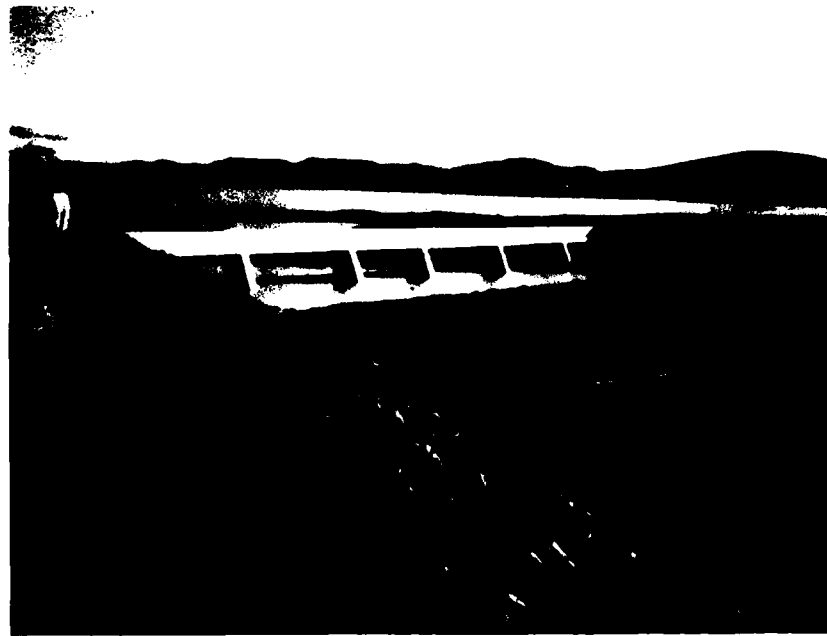

Figure 13. Fixed ice boom at Sigalda Reservoir, Tungnaa River, Iceland.

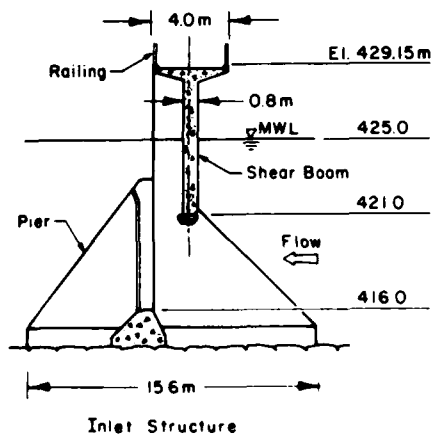

Figure 14. Inlet structure at Hrauneyjafoss Power Canal, Tungnaa River, Iceland.

would be more effective at keeping ice from the power canal than did a large (but relatively smaller) floating timber boom.\*

Fixed structures such as these are useful where the water level changes little. If seiches are large or the operation of ships is an important consideration, then a fixed beam would probably not be appropriate.

#### Stone groins

A groin is usually a rigid structure built out from

\*Personal communication with E. Tesaker, Trondheim, Norway, 1978.

shore to protect it from erosion, to trap sediment, or to direct the flow. Groin arrangements have been used for ice control at the Manasan Falls control structure on the Burntwood River in northern Manitoba, Canada, and at Hestefoss on the upper Pasvik River in northern Norway. At both places there are groins opposite each other across the river, and the Pasvik system has additional groins. Both arrangements are supplemented by ice booms upstream of the groins.

The Burntwood River was made part of the Churchill River Diversion, and its flows in winter were increased from  $28 \text{ m}^3/\text{s}$  to  $850 \text{ m}^3/\text{s}$ . Model studies indicated that frazil ice generation in the reach above Manasan Falls could lead to hanging dams, ice jams and flooding in Thompson, a city 6 km downstream (Hopper et al. 1977). The control structure at Manasan Falls was constructed to increase the upstream water levels sufficiently to promote the formation of a stable ice cover. It consists of two rock-filled groins creating a trapezoidal opening (Fig. 15). The two groins have upstream filters and seals, and the ends of the groins were protected by 0.9- to 1.2-m-diameter armor rockfill. The armoring material has remained stable at flows up to  $848 \text{ m}^3/\text{s}$  and at average water velocities in the gap exceeding 6 m/s. The opening has provided the required stage-discharge relationship and promoted the desired upstream ice cover (Janzen and Kuluk 1979, Hopper and Raban 1980). A larger hydroelectric dam planned for a nearby site will provide the ultimate solution to the problem.

On the Pasvik River a substantial amount of frazil

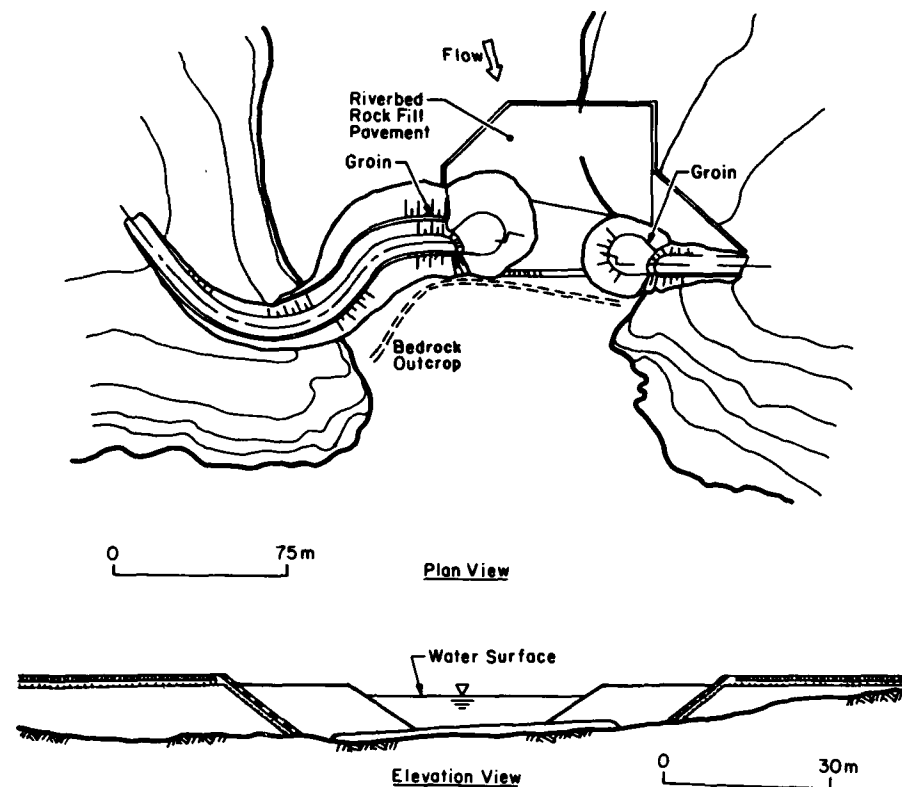

Figure 15. Ice control groins on the Burntwood River, Manitoba, Canada.

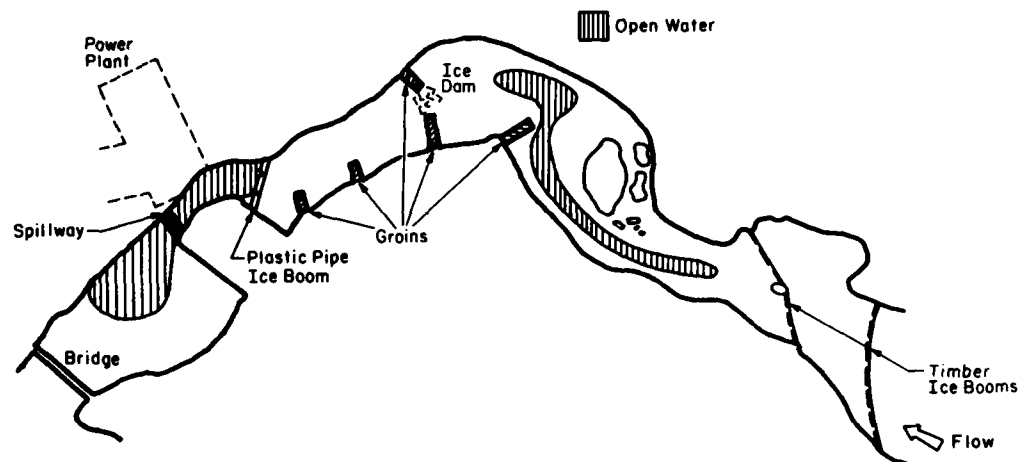

Figure 16. Ice control groins and booms on the Pasvik River, Hestefoss, Norway, showing the maximum ice conditions (early March).

and anchor ice is formed in the reach above the powerhouse at Hestefoss. Natural anchor ice dams as high as 3 m can form (Kanavin 1970), but they are poorly anchored to the riverbed and can break, causing heavy ice and transient water flows. The river was made narrower in the rapids area by installing stone groins to develop the basis for artificial ice bridges and to stabilize the ice dams (Fig. 16). To reduce the surface

area of open water and the amount of anchor ice, timber booms were installed above the rapids and a plastic pipe boom was installed below the rapids in the forebay of the powerhouse. After two years of observations the stone groins were functioning as expected.

The technology for groins is described in shore protection manuals. The applications described for ice are

not as simple as they seem, but groins may be the least expensive and most reliable method of ice control at a particular site.

#### Artificial islands

In the same manner that natural islands help hold ice in place, artificial islands can be used to help form, stabilize and retain an ice cover in certain locations. One example is the Lake St. Peter section of the St. Lawrence River, about 80 km downstream of Montreal, Canada (Fig. 17). Lake St. Peter is about 13 km wide and 32 km long and has an average depth of 3 m. Passing through the middle of the lake is a 240-m-wide navigation channel dredged to a depth of 10.7 m. The water flow velocity in most of the lake averages about 0.3 m/s, while in the channel it is 0.5 m/s.

To prevent floods in Montreal Harbor, a passageway for ice floes, slush and frazil ice is maintained by ice breakers from Montreal Harbor to Quebec City. At times, however, ice sheets would break free and be moved by wind and water to clog the passageway. Some light tower bases helped hold the ice, but more stabilization was needed. Once in a while a strong northeast wind would move the floating ice back upstream.

Several ice control structures were evaluated in various parts of Lake St. Peter and at Lavaltrie upstream in the river. Ice booms were successful but

pile clusters did not perform well. Danys (1975) suggested that the lake bed was probably too weak for the pilings to sustain the high ice forces. Artificial islands of three types were built in the lake. The most stable type for the existing conditions is shown in Figure 18a. The second type (Fig. 18b), which cost much less to build, is only as high as the mean winter high water level. A third type was formed by placing rip-rap around the substructures of old light piers. Light piers also aided in retaining an ice cover.

The islands were successful in forming and retaining a stable ice cover, and the winter navigation season was increased by an average of 30 days. The islands, especially the low ones, require maintenance because the foundations have settled and the slopes have been eroded by moving ice.

In 1980 three artificial islands were constructed in Lake St. Louis on the St. Lawrence River. The islands are permanent and located east of Ile Perrot and north of the navigation channel (Fig. 19). The islands were designed and constructed to help stabilize the ice cover north of the navigation channel, particularly during the spring breakup and the opening of the navigation season, eliminating the problem of large ice floes obstructing navigation. The effectiveness of the ice islands has not been fully assessed.

Ice islands have been helpful in some locations, but they were used only after the ice movements had been

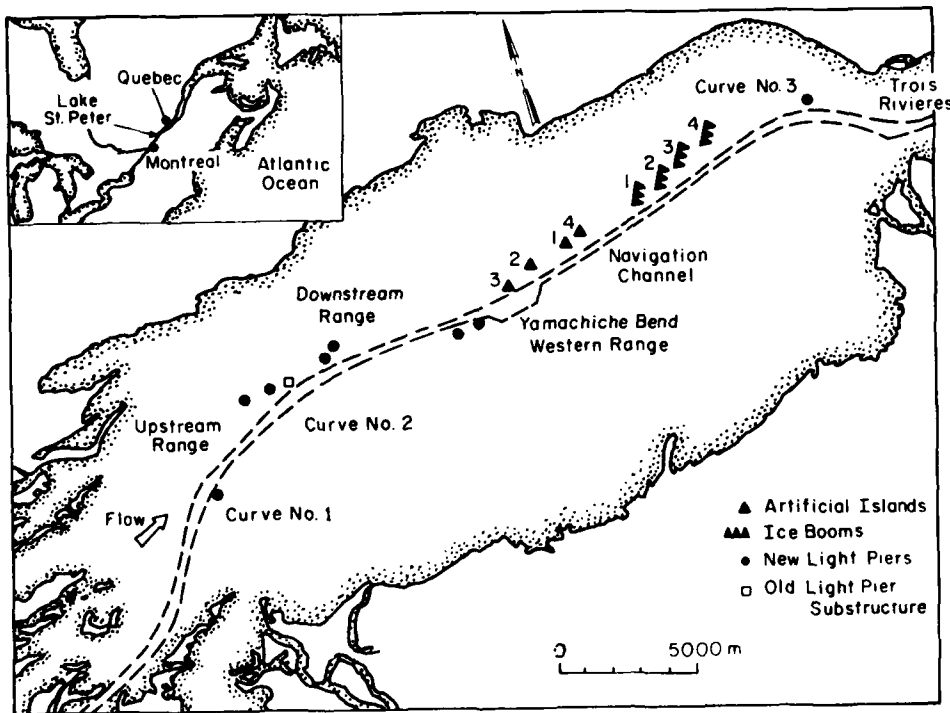

Figure 17. General plan and location of artificial islands, ice booms and light piers in Lake St. Peter.

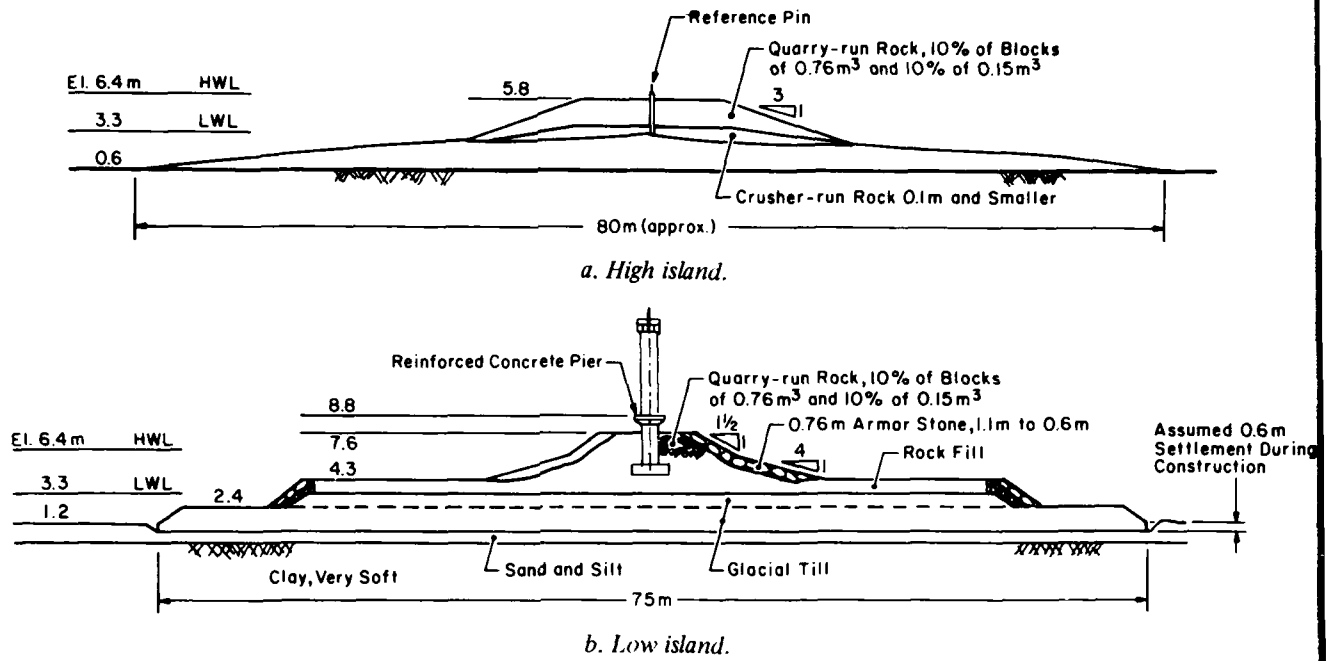

Figure 18. Cross sections of artificial islands in Lake St. Peter.

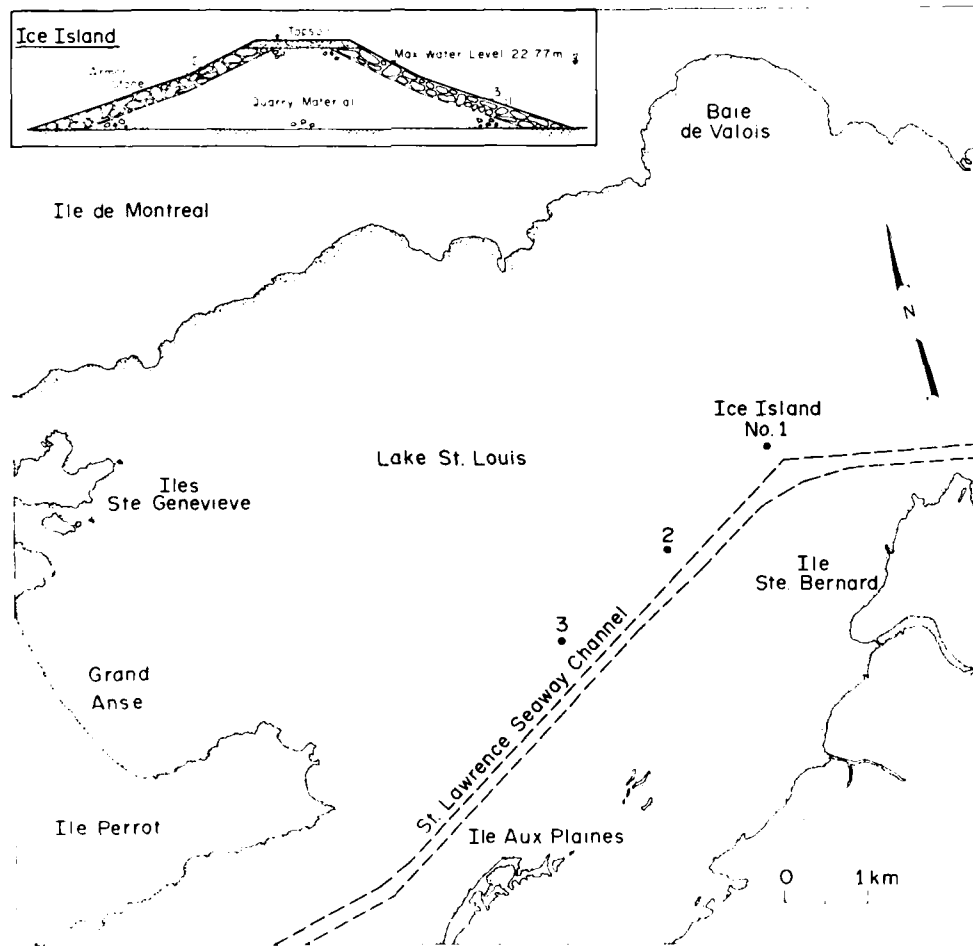

Figure 19. Ice-anchoring islands in Lake St. Louis, St. Lawrence River, near Chateaugay, Canada.

studied. Islands provide good lateral stability to the ice cover, but a small change in water elevation will fracture the ice near the islands. Ice on the lee side may move away from the island, but ice on the windward side will remain in position. Islands armored with stone cost more initially but have lower maintenance costs.

#### Removable gravity structures

A problem developed with the ice control boom in the harbor at Sault Ste. Marie, Michigan, because the ice cover above the boom would break free from shore and move laterally. Although the loads from the ice sheet were within the expected range, their distribution was different enough to cause damage when the boom timbers were frozen solidly into the ice cover. Damage could be prevented if the ice cover could be restrained from rotating. The only method that could be used was a removable gravity structure. The main structure used was a scow, surcharged to a total weight of 245 Mg and sunk in shallow water (Fig. 20). The scow is also secured with ship anchors. Each spring it is refloated and moved away. The method works very well (Perham 1981).

Sewage plant effluents can weaken this ice cover, so it was decided to supplement the ice-holding capability of the scow by placing a stack of crane weights in the shallow water of Soo Harbor, about halfway between the scow and the ice boom. The reinforced concrete crane weights are normally used on land for calibrating the load sensors on construction cranes and for testing their lifting capacity. They key to-

gether when stacked and are bound into a unit by wire ropes. The crane's six weights weigh a total of 0.86 Mg. They help reduce the rotating ice sheet problem to a manageable level.

The holding force available from gravity devices depends not only on the weight of the device in water but also on the coefficient of friction between the device and the bottom; a value of 0.3 was used here. The force level was estimated from the expected action of water and wind drag on the maximum expected ice sheet.

#### Timber cribs

Timber cribs are enclosed frameworks built of timber and packed with stone to make strong, stable structures. Many small dams were built using this type of construction and have lasted for 80 years or more. Log boom docks are usually stone-filled timber cribs.

An example of ice-restraining timber cribs is at the Narragausus River flood control project in the seacoast town of Cherryfield, Maine (Fig. 21). The upstream face of each crib is sloped. Treated timbers were used in the construction. Three cribs are located in a triangular pattern about 38 m upstream of a 2.1-m-high dam and spillway. The ice cover normally contacts the crib at approximately midheight.

The effectiveness of the timber cribs has not been measured, but they have remained in good condition for over 20 years. During this period severe ice jams have not occurred in the town, but the contribution of the timber cribs is unknown. The dam is undoubtedly the most important part of the project; the im-



Figure 20. Rock-filled scow stabilizing the ice cover in Soo Harbor, Michigan.



Figure 21. Ice-holding timber cribs in the Narragaugus River, Maine.

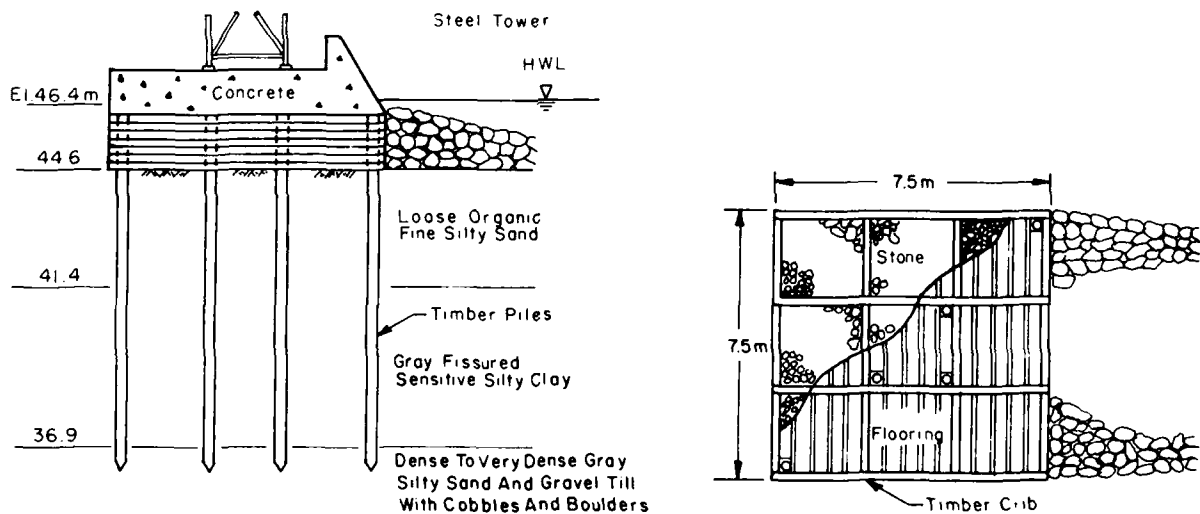

Figure 22. Stone-filled timber cribs and concrete caps used as light tower bases.

portance of the delay in ice cover movement at the dam caused by the cribs depends greatly on the tide water level.

Timber cribs have been used to support navigation light towers in several locations, such as Lake St. Francis and Lake St. Peter near Montreal on the St. Lawrence River. In this capacity they have also helped to anchor the ice cover in place (Danys 1975), but their usefulness on large lakes is in doubt. On poor foundation material the crib is supported by timber pilings (Fig. 22). Four small light piers were built on this type of subsurface structure in 1958 in Lake St. Fran-

cis. After receiving structural damage from ice thrust more piles were added and the concrete cap was changed from a flat slab to a smaller cylinder. The resistance to ice thrust based on a stability analysis was thus increased to 292–452 kN/m. Later, however, the cribs were replaced by conical, concrete light piers designed for a much larger ice thrust of 1495 kN/m (Danys 1977).

#### Weirs

Weirs are low-head dams built across streams to raise the water level. A weir of sufficient height forms

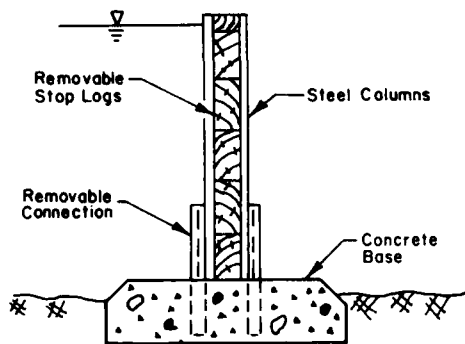

Figure 23. Timber weir.



Figure 24. Two-meter-high ice control weir on the Israel River, New Hampshire, with a moderate flow passing over the top.

a diversion pool with the low velocities that permit the formation of an ice cover; this, in turn, precludes the formation of frazil ice and anchor ice at the intake (Hayes 1974). The ice cover is restrained by the stream banks and the structure because of the narrow width. The weir can be built from stone, concrete or timbers (Fig. 23). A common feature is the capability of adding flashboards or stop logs to increase water levels for the winter operations.

The performance of a low-head weir as an ice control structure is being observed by Corps personnel on the Israel River in New Hampshire (Fig. 24). The site was once the location of a small hydropower dam. The weir was constructed using rock-filled gabion baskets containing an impervious sheet piling and covered by a concrete cap. The low-flow discharge passes through four 1.2-m-wide spillways. Preliminary indications are that the weir has only a small influence on the ice regime of the river. Observations of the structure's performance will continue so that its technical merit can be evaluated.

Weirs are used in combination with other structures to improve the ability of these structures to form an ice cover by reducing the local flow velocities in the pool. An ice control arrangement described by Groat (1920) used a stone weir to raise the water level at an ice control boom in the St. Lawrence River at Massena, N.Y. The boom consisted of a series of floating scows positioned between timber cribs. The flow velocities were 3-4.6 m/s. The stones had to be about 1.5 m across to be stable. Construction of the St. Lawrence waterway project in the late 1950s eliminated this site.

The stone weir used by Llamas (1965) with the dual cable boom described earlier is a good example of the effective use of natural materials (Fig. 25). The larger stones are set where the water velocities will be higher. Such an arrangement could be used on most streams and small rivers for testing ice control measures. If the results were favorable, a more permanent and ice-force-resistant structure could be built.

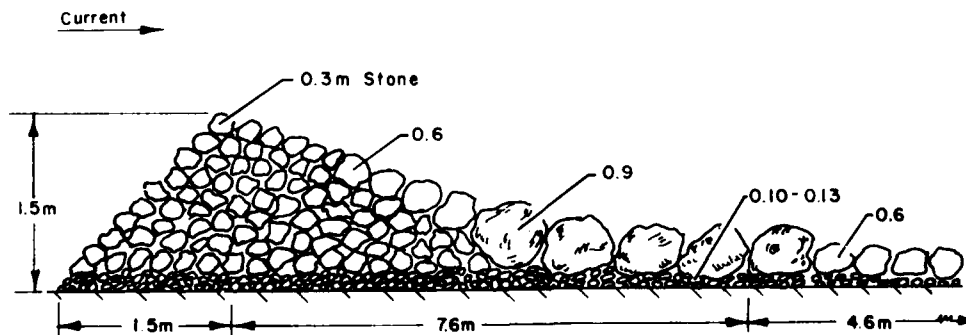

Figure 25. Stone weir used with experimental ice boom, Chaudiere River, Quebec.

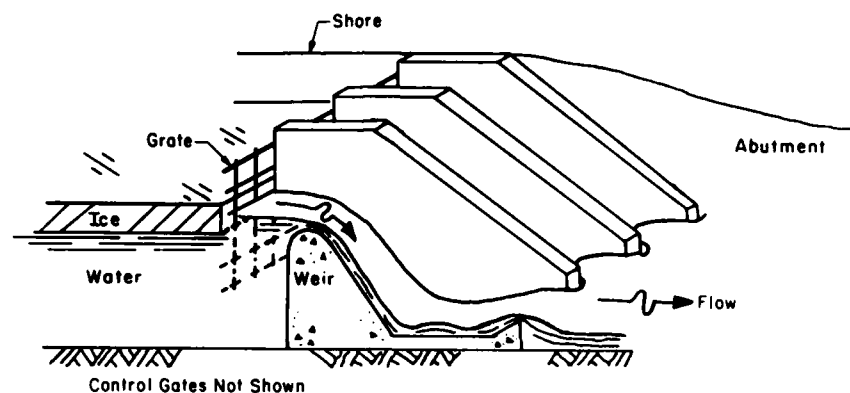

Figure 26. Weir and stationary grating on the Chaudiere River, Quebec.

A weir and stationary grating (Fig. 26) were also built on the Chaudiere River (Michel 1971). The grating collects ice floes, and an ice cover forms as above an ice boom. The grating, however, is stationary and supported far enough upstream of the weir crest to have little effect on the weir's performance. The main structure is built like a dam and contains gates to help maintain a fairly constant water level.

#### Pilings and dolphins

I found no examples of the use of single piles or lines of single piles for ice sheet retention. Instead, piles support a wharf or pier, and the whole assembly anchors or retains an ice sheet (Ekizian 1976). The effects of the vertical uplifting forces and horizontal forces from ice sheets must be considered for structures using exposed pilings; Wortley (1982) discussed these factors for lake ice.

Piling clusters, or dolphins, have received greater consideration for restraining ice. These are usually formed by a cluster of closely driven piles secured at the top with wire rope. Model tests of a line of individual pile clusters indicated that good ice retention was possible (Cowley et al. 1977). An installation of several timber clusters in Lake St. Peter in 1962, however, failed early in winter. The cause was attributed mainly to a very weak foundation and large ice forces (Danys 1975). Tests show that dolphins have surprisingly little resistance to steady lateral pulls (Chellis 1951).

A dolphin in the Bourne Canal on Cape Cod, Massachusetts, resisted ice action for several years but eventually failed from the action of ice floes moving in water currents with velocities up to 3.1 m/s. A replacement dolphin made of 21 steel H piles is being built in the 10-m-deep water.

Besides vertical and horizontal forces the effect of ice abrasion is an important consideration. It is possible for ice to sever timber pilings in a matter of hours

(Kirkham 1929). Oak pilings are fairly ice resistant, but timber structures generally last only about 20 years as a result of ice abrasion. Timbers can be protected by steel armor. Concrete can also be adversely affected by ice abrasion and by the spalling off of material from repetitive freezing and thawing of ice on its surface (Miller 1974).

#### STRUCTURES BUILT FOR OTHER PURPOSES

The formation and retention of ice covers can be aided by structures that were not built for that purpose. Flows over hydroelectric dams can be manipulated to help an ice cover form. Other structures, such as wicket dams and bridge piers, aid in the formation and retention of ice covers simply by their presence.

#### Hydroelectric dams

It is possible to aid the formation of an ice cover on rivers by increasing flow depths and decreasing flow velocities at strategic times during the early winter. This capability must be accompanied by a comprehensive understanding of the hydraulics and ice conditions on the river and how it responds to various meteorological influences. Usually ice sheet retention structures are needed too.

An example is the operation of the Beauharnois Canal and powerhouse on the St. Lawrence River about 40 km west of Montreal, Quebec. Here the Coteau diversion structure sends nearly all the flow of the St. Lawrence River at Lake St. Francis down the 25-km-long by 1-km-wide canal to pass through the powerhouse and into Lake St. Louis. The installed capacity of the plant is 1564 MW.

The Beauharnois Canal has a forebay ice boom spanning the canal and six upstream booms that con-

tain gaps allowing ice floes to pass through and collect at the forebay boom. The forebay boom is instrumented for forces so that the operators can tell when an ice cover is starting there, even when the canal is obscured by blizzards (Perham and Raciot 1975). In early winter a small icebreaker breaks ice in Lake St. Francis to increase the collection of ice on the canal. At this time, average flow velocities in the canal are reduced from 0.70 m/s to 0.46 m/s, which allows an ice cover that is smooth on its underside to form on the canal. Higher velocities would cause a rougher ice cover to develop, reducing power generation. The formation process takes from a week to 10 days; after the ice cover stabilizes behind the booms, the flows are increased gradually to near-summer levels, 0.70 m/s. The short-term flow reductions are more than compensated for by improved flow conditions throughout the remainder of the winter. The force instruments monitor the stability of the ice cover throughout the winter. Over the many years it took to develop this equipment and these procedures, the power plant has improved its winter output by approximately 200 MW.

Another example of operator control is the International Section of the St. Lawrence River, which is controlled by the hydroelectric plants at Massena, New York, and Cornwall, Ontario. Six ice booms are located about 62 km upstream of the dam. The progression of the ice cover is monitored closely. River flows are adjusted according to the location of the ice edge and the weather conditions so that a smooth ice cover will develop; this provides the best hydraulic efficiency in the river during winter.

As the ice edge nears the high-velocity reach a few kilometers below Iroquois Dam, the gates are lowered 4.5–6 m under water. This cuts off the supply of ice floes to the downstream reach, where a hanging dam might develop. The unconsolidated ice cover continues to develop from the dam up to its local limit of the Galop Cut at Cardinal, Ontario. Wigle et al. (1981) describe the procedures in detail.

#### Wicket dams

A wicket dam comprises a series of rectangular elements or wickets that are propped side by side and on end to form a sloping dam face (Fig. 27). A typical wicket is 0.3 m thick by 1.1 m wide by 5 m long. The elements are raised and lowered by a barge-mounted crane, and usually they increase the upstream water level from 1.8 to 2.4 m. They have been used on rivers such as the Ohio for maintaining the high water levels needed for navigation during times of low flows. In this way they intrinsically help to form and maintain an ice cover.

#### Light piers and towers

Light piers and towers are used to mark the locations of navigation channels and courses. These structures can be built on land, but many are built offshore, where they become frozen into the ice sheet. Should the ice sheet break free from shore, a high force can be applied to the pier or tower. If the force is great enough, either the ice or the tower will yield. Ice loading also develops on a light pier structure when the ice on the channel side of the structure has been broken or removed while the ice cover is still intact between the light pier and the shore; the thrust is probably due to thermal expansion of the solid ice (Striegl 1952). Dany (1977) studied the ice forces on many of the old and new light piers in the St. Lawrence waterway system from 175 km downstream of Quebec City to the Great Lakes. He gives condensed but practical information about a variety of light piers.

Timber cribs were used for substructures until about 20 years ago, but reinforced concrete and steel shells are now used. New light piers are usually cone-shaped where they touch the ice; the slope of the cone is usually 45°. A typical light pier is shown in Figure 28. As in most designs where ice is involved, it is important to select a realistic design ice thickness. For this light pier a thickness of 0.60 m was selected based on previous measurements of 0.45–0.50 m. More recent measurements showed, however, that ice thicknesses may reach 0.80 m; a design ice thickness of 0.90 m is now used.

A U.S. Coast Guard light pier being built in Lake St. Clair is shown in Figure 29. The base of the light pier is stabilized by a ring of sheet steel pilings and a central arrangement of driven piles. Its conical top is welded to the upper end of the sheet piling ring. The core of the pier is filled with stone, while reinforced concrete fills the cone and the top of the pile cylinder. A relatively small tower and light are mounted on top.

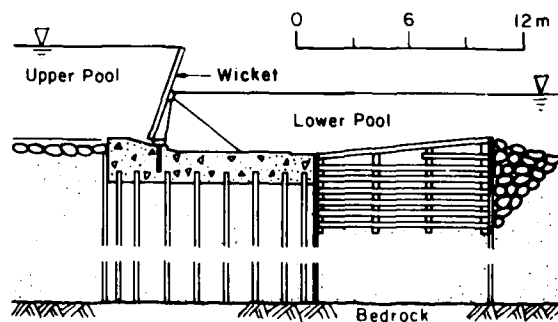

Figure 27. Typical section of a navigable pass portion of a wicket dam, Ohio River Lock and Dam No. 10, Steubenville, Ohio. The upper pool averages 2.3 m above the lower pool.

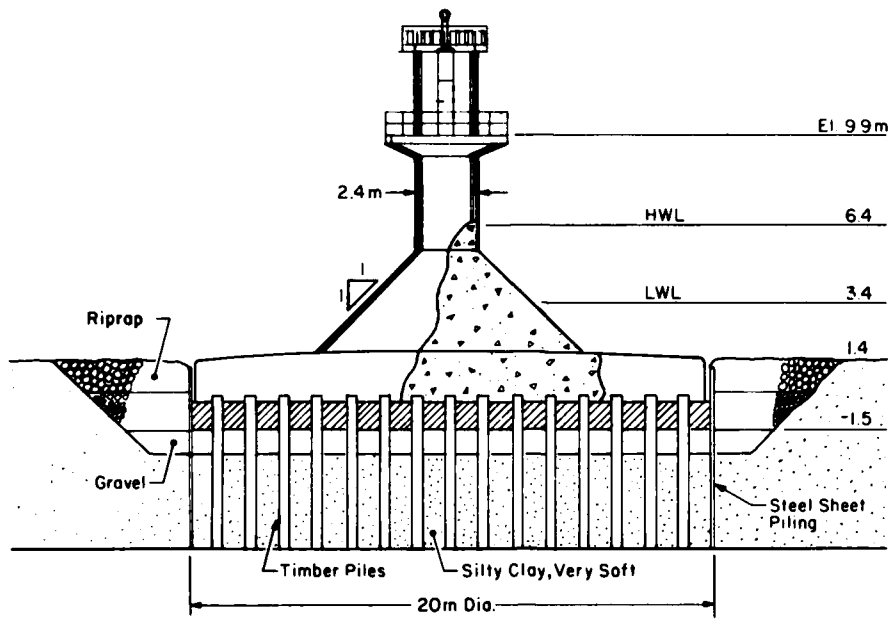

Figure 28. Light pier built in 1968 on Lake St. Peter, Canada.

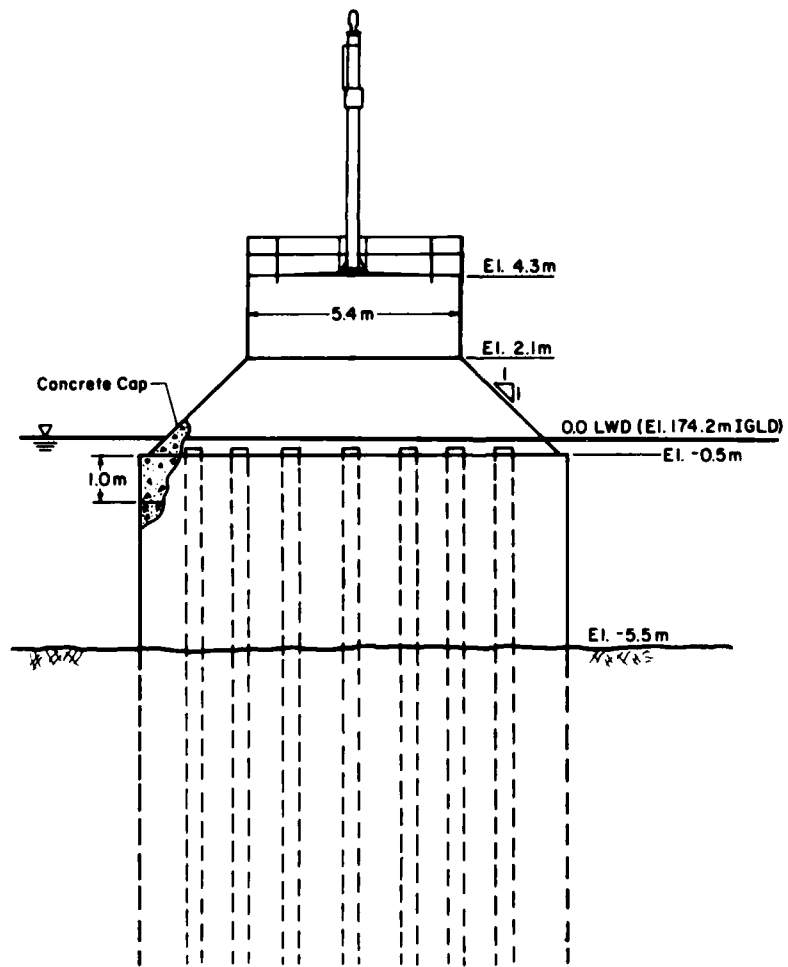

Figure 29. Light no. 14 on Lake St. Clair, Michigan.

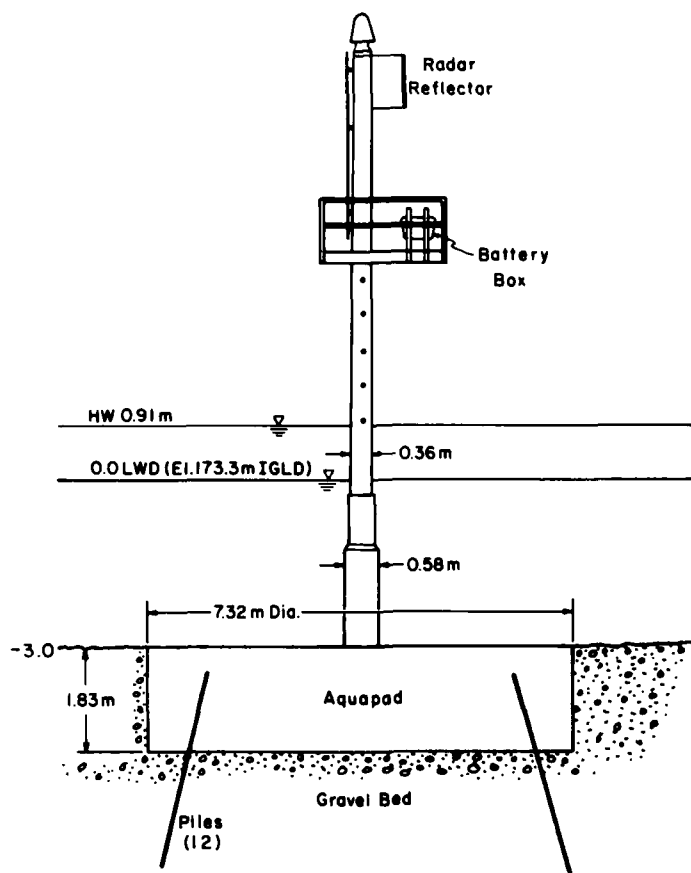

Figure 30. Steel light tower on Maumee Bay, Lake Erie. The tower has a square cross section.

The all-steel light tower shown in Figure 30 is located about 5 km offshore in Maumee Bay on Lake Erie. A key to the tower's survival is undoubtedly its large wheel-like base, which is fixed in place by several pilings.

#### Bridge piers

Bridge piers often constrict the river flow, and ice floes may collect at the piers in early winter to form an unconsolidated ice cover. Border ice growth on the piers can increase this narrowing effect at the water's surface if the spacing is small. Under some circumstances, however, this channel narrowing may lead to water velocities that are too high to allow an ice cover to form. Dynamic, static and thermal ice pressures and ice abrasion must be considered in designing bridge piers. Neill (1976) gives an excellent review of ice effects on bridge piers.

#### Breakwaters

A breakwater is a structure protecting a shore area, harbor, anchorage or basin from wave action. Stationary breakwaters can increase ice cover stability

and bear the brunt of forces from moving ice that would otherwise affect the areas protected by the breakwaters. This is not generally the case with floating breakwaters.

Breakwaters may be constructed from rubble mounds, cast concrete elements, concrete caissons, sheet-piling cells, or cribs, or be prefabricated and moved into place. In the United States, breakwaters built on the open coast are generally of rubble mound construction. Occasionally, they are modified into a composite structure by using a concrete cap for stability.

Guidance with respect to ice forces and wave data are found in the Shore Protection Manual (U.S. Army Corps of Engineers 1973). A paper by Czerniak et al. (1981) gives an excellent but general summary of design factors for rubble mound structures under severe ice and wave action.

Normally the wave forces on shore structures are comparable in magnitude to the maximum probable pressure that might be developed by an ice sheet. As the maximum wave forces and ice thrust cannot occur at the same time, usually no special allowance is made for overturning stability to resist ice thrust. However,

where heavy ice, either in the form of a solid ice sheet or floating ice fields may occur, adequate precautions must be taken to ensure that the structure is secure against sliding on its base. Other problems such as gouging, abrasion, local failures, ice ride up and ice cover transport of materials exist.

## ICE CONTROL NOT USING STRUCTURES

### Channel improvements

The cost of channel improvements is usually very high, and often there are many other social and environmental factors that prohibit their implementation. The best way to predict how certain improvements will affect the winter operation of a waterway is to accurately simulate the present and future conditions in a physical, hydraulic model. Changes that reduce average water velocities and velocities at local points of acceleration generally help to form and maintain an ice cover. The most reliable improvements are to make the channel deeper and straighter and to remove midstream obstructions that cause high-velocity zones (Lotter 1932).

### Ice sheet tying

Large, broken pieces of ice can be tied together with rope to keep them from moving from one location and to another. Broken ice can be tied to shore-fast ice in the manner that was used on the Mississippi

River at Prairie du Chien, Wisconsin, in 1981 for an emergency ferry track. Holes were drilled through the ice about 1 m from both sides of the crack. A forearm-sized stick of wood with a rope centrally attached was set across each hole beneath the ice. The two rope ends were tied together across the crack to make a tight connection. The ropes were tightened by twisting them with another stick (Fig. 31). Braided rope 6.4–12.5 mm in diameter worked best. Ties spaced from 3–10 m apart were sufficient. A line spanning several sheets provided more reliability in some instances. Unless they were covered with snow, lines frozen to the surface melted free due to solar radiation.

### Ice sheet bridges

Barnes (1928), in referring to a report of the Montreal Flood Commission, mentions events in the St. Lawrence River "where a bridge is formed artificially by sawing off enough bordage [border] ice and swinging it across the channel to an island, to give communication with the mainland." Kanavin (1944) used this technique for ice control on the Dvina River in eastern Europe. A section of border ice was sawed out and placed diagonally across the river. Drift ice coming from the upper reaches of the river was halted by this barrier and froze into a solid ice cover. The purpose of the bridges was to develop ice covers on rapids, where tremendous quantities of anchor ice and frazil ice were generated.

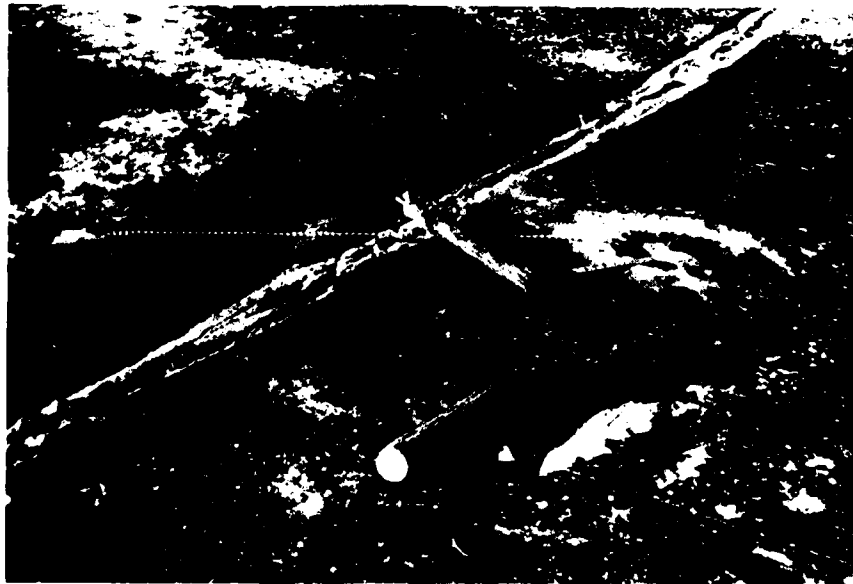

Figure 31. Ice sheet retention by tying with lines, Mississippi River, Prairie du Chien, Wisconsin, 1981.

## CONCLUSIONS

Ice sheets may be retained in many ways, including a wide variety of structures, anchoring techniques, flow modifications and natural effects. An engineer must understand the physical processes of ice sheet formation and ice-structure interaction before selecting a structure for a particular application. Mathematical relationships are available for estimating the effects of physical phenomena. Physical hydraulic model studies should precede the design and installation of most prototype structures.

## LITERATURE CITED

- Ashton, G.D.** (1974) Froude criterion for ice block stability. *Journal of Glaciology*, 13(68): 307-313.
- American Society of Civil Engineers and United States Committee on Large Dams** (1967) *Joint ASCE-US COLD Committee on Current United States Practice in the Design and Construction of: Arch Dams, Embankment Dams and Concrete Gravity Dams*. New York: American Society of Civil Engineers.
- Barnes, H.T.** (1928) *Ice Engineering*. Montreal: Renouf Publishing Company.
- Bishop, C.T.** (1980) Design and construction manual for floating breakwaters. Unpublished report or draft manual, Hydraulic Division, National Water Research Institute, Burlington, Ontario, Canada.
- Bolsenga, S.J.** (1968) River ice jams—A literature review. U.S. Army Corps of Engineers Lake Survey District, Detroit, Michigan, Research Report 5-5.
- Boulanger, F., E. Dumalo, D. Levan and L. Raciot** (1975) Ice control study—Lake St. Francis—Beauharnois Canal, Quebec, Canada. *Proceedings of the Third International Symposium on Ice Problems, IAHR, 18-21 Aug, Hanover, N.H.*, pp. 39-48.
- Bryce, J.B. and G.T. Berry** (1967) Lake Erie—Niagara ice boom. *Transactions of the Engineering Institute of Canada*, 1: 28-35.
- Bureau of Reclamation** (1960) Design of small dams. U.S. Department of Interior, Denver Federal Center, Denver, Colorado.
- Calkins, D.J., R. Hayes, S.F. Daly and A. Montalvo** (1982) Application of HEC-2 for ice-covered waterways. *Journal of the Technical Councils of ASCE, Proceedings of the American Society of Civil Engineers*, 108(TC2): 241-248.
- Carstens, T.** (Ed.) (1980) Working group on ice forces on structures. USA Cold Regions Research and Engineering Laboratory, Special Report 80-26. ADA089 674.
- Cartier, L.** (1959) Field investigations of some ice cover problems in an experimental canal. *Proceedings of the 16th Annual Meeting, Eastern Snow Conference*, pp. 45-54.
- Chellis, R.O.** (1951) *Pile Foundations: Theory-Design-Practice*. New York: McGraw-Hill Book Company, Inc.
- Creager, W.P. and J.D. Justin** (1950) *Hydroelectric Handbook*. New York: John Wiley and Sons.
- Cowley, J.E., J.W. Hayden and W.W. Willis** (1977) A model study of St. Marys River ice navigation. *Canadian Journal of Civil Engineering*, 4: 380.
- Czerniak, M.T., A.T. Shak and J.I. Collins** (1981) Design factors for rubble mound structures under ice and wave attack. *Proceedings of the Sixth International Conference on Port and Ocean Engineering Under Arctic Conditions, Quebec, Canada, July 27-31*. 3: 1239-1258.
- Danys, J.V.** (1975) Ice movement control by the artificial islands in Lac St. Pierre. *Proceedings of the Third International Symposium on Ice Problems, IAHR, 18-21 Aug, Hanover, N.H.*, pp. 81-91.
- Danys, J.V.** (1977) Ice forces on old and new offshore lighthouses in the St. Lawrence Waterway. *Proceedings of the Fourth International Conference on Port and Ocean Engineering Under Arctic Conditions, Memorial University of Newfoundland, St. Johns, September 26-30*, pp. 1-24.
- Deck, D. and G. Gooch** (1981) Ice jam problems at Oil City, Pennsylvania. USA Cold Regions Research and Engineering Laboratory, Special Report 81-9. ADA103736.
- Deck, D. and R. Perham** (1981) Evaluating the effects of installing a floating ice control structure in the Allegheny River at Oil City, Pa. Draft Report for U.S. Army Engineer District Pittsburgh, U.S.A Cold Regions Research and Engineering Laboratory.
- Deslauriers, C.E., J. Llamas, C. Triquet, R. Lavattee and B. Michel** (1965) Plan d'ensemble des travaux remediateurs de la Riviere Chaudiere. Ministry of Natural Resources of Quebec, Canada.
- Devik, O.** (1964) Present experience on ice problems connected with the utilization of water power in Norway. *Journal of Hydraulic Research, IAHR*, 1: 25-40.
- Dingman, S.L., W.F. Weeks, Y.-C. Yen and A. Assur** Effects of thermal pollution on river ice conditions. Part 1. A general method of calculation. USA Cold Regions Research and Engineering Laboratory, Research Report 206. AD666205.
- Ekizian, H., Jr.** (1976) Anchorage port survives nature. *Civil Engineering-ASCE*, 46(12): 64-67.
- Flaman, M.T.** (1978) Final report on the St. Lawrence development ice boom strain links. Ontario Hydro Research Division, Toronto, Report No. B78-77-K.
- Foulds, D.M.** (1974) Ice problems at water intakes. *Canadian Journal of Civil Engineering*, 1: 137-140.
- Granbois, K.J.** (1953) Combatting frazil ice in hydro-

- electric stations. *Transactions of the American Institute of Electrical Engineers*, April.
- Groat, B.F.** (1920) Ice diversion for St. Lawrence River Power Co. *The Canadian Engineer*, 39: 545-552.
- Hayes, R.B.** (1974) Design and operation of shallow river diversions in cold regions. Bureau of Reclamation Engineering and Research Center, Denver, Colorado, Report No. REC-ERC-74-19.
- Hopper, H.R., C.P.S. Simonson and W.J.S. Poulter** (1977) Churchill River diversion—Burntwood River waterway winter regime. *Proceedings of the Third National Hydrotechnical Conference, Canadian Society for Civil Engineering, 30-31 May, Quebec*, pp. 434-452.
- Hopper, H.R. and R.R. Raban** (1980) Hanging dams in the Manitoba hydro system. *Proceedings of Workshop on Hydraulic Resistance of River Ice, National Water Research Institute, Canada Centre for Inland Waters, Burlington, Ontario, Sept 23-24*, pp. 195-208.
- Janzen, P. and A.G. Kuluk** (1979) Manasan Falls control structure design and construction aspects. *Canadian Geotechnical Journal*, 16: 479-510.
- Kanavin, E.V.** (1944) Ice conditions in eastern Europe and the methods employed to influence the formation and break-up of the ice on the Dvina (Daugava) River. Report of the Directorate of Technology and Transport, Division of Hydrology, Riga. Technical Translation TT-85, National Research Council of Canada, Division of Mechanical Engineering, Ottawa, Canada.
- Kanavin, E.V.** (1970) Experience with ice problems in the Pasvik River. *Proceedings of the IAHR Symposium on Ice and Its Actions on Hydraulic Structures, Reykjavik, Iceland*.
- Kirkham, I.E.** (1929) Design of ice breaker nose for Missouri River bridges. *Engineering News Record*, 99(9): 354-355.
- Kivisild, H.R.** (1959) Hanging ice dams. *Proceedings of the Eighth International Association for Hydraulic Research Congress, Montreal, August*.
- Latyshenkov, A.M.** (1946) Design factors for river ice booms analyzed. *Gidrotekhnicheskoe Stroitel'stvo*, 15(4): 13-19. Also USA Cold Regions Research and Engineering Laboratory, Draft Translation TL 485. ADA014886.
- Lawrie, C.J.R.** (1972) Ice control measures on the St. Lawrence River. *Proceedings of the 29th Annual Eastern Snow Conference, Oswego, N.Y.*, pp. 123-146.
- Llomas, J.** (1965) Plan d'ensemble des remedeurs de la Riviere Chaudiere, Annex B, Observation Cryologiques sur la R. Chaudiere. Ministry of Natural Resources of Quebec, Canada. Translated by U.S. Lake Survey, Detroit, 1967.
- Lotter, G.K.** (1932) Influence of conditions accompanying ice formation and ice thickness on the design of diversion canals. (Russian text, English summary.) *Izvestiia Nauchno-Issledovatel'skogo Instituta Gidrotekhniki*, 7: 55-81.
- McLachlan, D.W.** (1927) Ice formation on the St. Lawrence and other rivers. Appendix E. Joint Board of Engineers Report, St. Lawrence Waterway Project.
- Michel, B.** (1966) Thrust exerted by an unconsolidated ice cover on an ice boom. Conference on Ice Pressure, Snow and Ice Subcommittee, National Research Council, Laval University, Nov 6-11.
- Michel, B.** (1970) Ice pressure on engineering structures. USA Cold Regions Research and Engineering Laboratory, Monograph III-B1b. AD709625.
- Michel, B.** (1971) Winter regime of rivers and lakes. USA Cold Regions Research and Engineering Laboratory, Monograph III-B1a. AD724121.
- Miller, D.S.** (1974) Materials and construction techniques for floating breakwaters. In *Proceedings of the Floating Breakwaters Conference* (T. Kowalski, Ed.). Marine Technical Report Series Number 24, University of Rhode Island, Narragansett, pp. 247-261.
- Morrison, I.E.** (1972) Synthetic fibre ice boom. Unpublished report, Ministry of Transport, Marine Services, Montreal District, Montreal, Quebec.
- Morrison, I.E.** (1973) Ice boom tension gauge. Unpublished report, Ministry of Transport, Marine Services, Montreal District, Montreal, Quebec.
- Neill, C.R.** (1976) Dynamic ice forces on piers and piles. An assessment of design guidelines in light of recent research. *Canadian Journal of Civil Engineering*, 3(2): 305-341.
- Pariset, E. and R. Hausser** (1961) Formation and evolution of ice covers on rivers. *Transactions of the Engineering Institute of Canada*, 5(1): 41-49.
- Pariset, E., R. Hausser and A. Gagnon** (1966) Formation of ice covers and ice jams in rivers. *Journal of the Hydraulics Division, ASCE*, 92(HY6): 4965-4989.
- Perham, R.** (1974) Forces generated in ice boom structures. USA Cold Regions Research and Engineering Laboratory, Special Report 200. AD775822.
- Perham, R.** (1976) Some economic benefits of ice booms. *Proceedings of the Second International Symposium on Cold Regions Engineering, University of Alaska, Fairbanks, 12-14 Aug*, pp. 570-591.
- Perham, R.** (1977) St. Marys River ice booms: Design force estimate and field measurements. USA Cold Regions Research and Engineering Laboratory, CRREL Report 77-4. ADA037902.
- Perham, R.E.** (1978) Righting moment in a rectangular ice boom timber or pontoon. *Proceedings of the IAHR Symposium on Ice Problems, Lulea, Sweden, 7-9 August*, pp. 273-286.
- Perham, R.E.** (1981a) An ice control arrangement for winter navigation. *Proceedings of the Specialty Conference, Water Forum 81, American Society of Civil*

- Engineers, San Francisco*, pp. 1096-1103.
- Perham, R.** (1981b) Tests of frazil collector lines to assist ice cover formation. *Canadian Journal of Civil Engineering*, 8: 442-448.
- Perham, R.** (1982) Preliminary results of field test of a 4.9×15.2 m frazil collector line array. USA Cold Regions Research and Engineering Laboratory, Technical Note (unpublished).
- Perham, R. and L. Raciot** (1975) Forces on an ice boom in the Beauharnois Canal. *Proceedings of the Third International Symposium on Ice Problems, IAHR, Hanover, N.H., 18-21 Aug*, pp. 397-407.
- Schaefer, V.J.** (1950) The formation of frazil and anchor ice in cold water. *Transactions, American Geophysical Union*, 31: 885-899.
- Stevens, J.C.** (1940) Winter overflows from ice gorging on shallow streams. *Transactions, American Geophysical Union, Part III*, pp. 973-978.
- Stewart, D.M. and G.D. Ashton** (1978) Entrainment of ice floes into a submerged outlet. *Proceedings of the IAHR Symposium on Ice Problems, Lulea, Sweden, 7-9 Aug*, pp. 291-299.
- Stothart, C.D. and J. Croteau** (1965) Montreal ice control structure. *Proceedings of the 22nd Annual Eastern Snow Conference, Hanover, N.H., Feb 4-5*, pp. 25-40.
- Striegl, A.R.** (1952) Ice on the Great Lakes and its engineering problems. *Symposium on the Natural Setting and Engineering Problem, Joint Meeting of the American Meteorological Society and American Geophysical Union, Chicago, Illinois*.
- Tsang, G.** (1982) Resistance of the Beauharnois Canal in winter. *Journal of the Hydraulics Division, ASCE*, 108(HY2).
- U.S. Army Corps of Engineers** (1960) Cherryfield Dam and Reservoir, local protection project, Narragansett River, Cherryfield, Maine—Detailed project report. New England Division, Waltham, Massachusetts.
- U.S. Army Corps of Engineers** (1973) Shore protection manual. U.S. Army Coastal Engineering Research Center, Fort Belvoir, Virginia.
- U.S. Army Corps of Engineers** (1979) St. Marys River-Little Rapids Cut ice boom and its effects on level and flows in the Soo Harbor, winter 1978-79. Detroit District, Detroit, Michigan.
- U.S.S.R. Code** (1976) Loads exerted on hydraulic structures by waves, ice and ships. SNiP-11-57-75 Construction Standards and Rules, Part II. Design Standards Chapter 57, Moscow. Technical Translation No. NRC/CNR TT-1968, Canada Institute for Scientific and Technical Information, National Research Council, Ottawa.
- Uzuner, M.S. and J.F. Kennedy** (1972) Stability of floating ice blocks. *Journal of the Hydraulics Division, ASCE*, 98(HY12): 2117-2133.
- Wigle, T.E., J. Bartholomew and C.J.R. Lawrie** (1981) Winter operations: International section of the St. Lawrence River. *Proceedings of the IAHR International Symposium on Ice, Quebec City, July*, pp. 193-202.
- Wortley, C.A.** (1982) Ice engineering design of marine piling and piers. *Journal of the Technical Councils of ASCE, Proceedings of the American Society of Civil Engineers*, 108(TC2): 200-213.

## APPENDIX A: ICE CONTROL STRUCTURES

**Table A1. Flexible ice control structures.**

Type of structure	Figure no.	General function*	Water body	Material	Dimensions (m)	Span (m)	Force level† (kN/m)
<b>Ice booms</b>							
Single timber		icfs, p	St. Lawrence R.	Douglas fir	0.36x0.56x9.1	122	8.4 <sup>m</sup>
	4c	icfs, p	Lake Erie	Douglas fir	0.36x0.56x9.1	122	20.1 <sup>d</sup>
	4c	icfs, n	Lake St. Peter	Douglas fir	0.36x0.56x9.1	122	9.4 <sup>m</sup>
	3	icfs, n	St. Marys R.	Douglas fir	0.30x0.61x6.1	62.5	10.7 <sup>m</sup>
Double timber	4f	icfs, n, p	Lake St. Francis	Douglas fir & steel	0.36x0.56x0.91	122	Unknown
		icfs, ijr	Oil Creek	Douglas fir & steel	0.83x0.83x6.1; 0.67x0.67x4.9	38.1	6.7 <sup>m</sup>
Single pontoon	4a	icfs, ijr	Des Prairies R.	Hollow steel	0.41x0.81x6.1	68.6	43.8 <sup>e</sup>
	6	icfs, n, p	Lake St. Francis	Hollow steel	0.41x0.81x6.1	61	16.1 <sup>d</sup>
	7	icfs	Allegheny R.	Steel; filled with foam	0.41x0.81x6.1	152	16.4 <sup>d</sup>
Double pontoon	4g	icfs, n, p	Beauharnois Canal	Hollow steel pontoon; steel frame	0.91(diam)x6.1; parallel pontoons, 1.83 on center	36	46.7 <sup>m</sup>
Single timber (direct load)		icfs, t, p	St. Marys R.	Timbers	Miscellaneous	21.3	Unknown
Rope	4e, 8	icfs, x	St. Lawrence R.	Nylon & polypropylene braided rope	0.18(diam)x91	80.5	Unknown
Plastic pipe	4d, 16	icfs, p	Pasvik R.	Plastic pipe; steel wire rope	0.30 (diam)	Unknown	Unknown
Shear booms	4i	t, d	Missouri R.	Steel pipe; wood planks	0.34-0.41(diam)x12.2	122	Unknown
	4h	t, d	New Clayton Lake	Steel pipes; wood planks	0.41-0.51(diam)x7.3	216	Unknown
Scow boom and weir		icfs	St. Lawrence R.	Scow; stone weir	1.4 (avg scow depth); 2.5 (height of weir)	~238	Unknown
Timber boom and weir	25	icfs	Chaudiere R.	Wood timbers; steel cable; concrete piers	1.5 (height of weir); 1.2 (height of boom)	43	14.6 <sup>d</sup>
Frazil collector lines	9	icfs, x	Ottawaquechee R.	Braided nylon line	15.2 (lengths of lines); 0.15 (spacing between lines); 98% open	4.9	0.07-0.11 <sup>s</sup>
Fence boom	10, 11	icfs, ijr, x	Mascoma R.	Wood 2x4s; wire rope	1.22 (height); 0.90 (gaps); 70% open	16.5	11.7 <sup>d</sup>

\* icfs = ice cover formation and stabilization

d = shear or diversion

t = trash collection or diversion

ijr = ice jam reduction

x = experimental

p = hydroelectric power

n = navigation

† m = measured

d = design criterion

e = estimated from damage

s = shear drag coefficient

<i>Water depth (m)</i>	<i>Avg. water velocity (m/s)</i>	<i>Organization</i>	<i>References</i>	<i>Notes</i>
5.2-14.9	0.29-0.84	Ontario Hydro, Cornwall & Toronto, Ontario; PASNY, Massena, New York	Flaman (1978), Perham (1974)	
5.5	0.46	Ontario Hydro, Niagara Falls, Ontario; PASNY, Niagara Falls, New York	Bryce & Berry (1967), Perham (1976)	
3	0.30	Transport Canada, Marine Services, Montreal	Morrison (1973)	
3-9.4	0.82	Detroit District, U.S. Army Corps of Engineers	Perham (1976, 1978), Cowley et al. (1977)	76.2-m-wide opening between boom ends for ship navigation
7.9	0.76	Hydro Quebec, Montreal	Perham & Raciot (1975)	
0.6	0.49	CRREL and Oil City, Pennsylvania	Deck (pers. comm.)	
4.6	0.52-0.85	Hydro Quebec, Montreal	Raciot (pers. comm.)	
6.1	0.43	Seaway Transport Canada, St. Lambert, Quebec	Lock & Sutt (pers. comm.)	
1.65	0.35	Pittsburgh District, U.S. Army Corps of Engineers	Deck & Perham (1981)	
10.4	0.73	Hydro Quebec, Montreal	Perham & Raciot (1975), Tsang (1982)	Maximum ice force measured during late winter ice jam
3.4	0.58	Edison Sault Electric Co., Sault Ste. Marie, Michigan	Perham (1976)	Timbers connected end to end
6.7	0.61-0.76 1.22-1.83	St. Lawrence Ship Channel Division, Ministry of Transport, St. Lambert, Quebec	Morrison (pers. comm.)	Tested in two locations
Unknown	Unknown	Power plant, Hestefoss, Norway	Kanavin (1970)	Timber boom used upstream
~10	>1.83	Montana Power Co., Great Falls, Montana	Taylor (pers. comm.)	Sometimes used as ice boom
37	Unknown	Appalachian Electric Power Co., Clayton Development, Virginia	Creager & Justin (1950)	Sometimes handles ice
~4	3-4.6		Groat (1920)	Boom can pass ice during high flows
≤3.4	≤2.6	Quebec Ministry of Natural Resources	Deslauriers et al. (1965)	
0.3-0.5	0.73-1.1	CRREL	Perham (1982)	0.1-m spacing recommended
0.4-0.5	0.43	CRREL	Perham (1982)	

Table A2. Rigid or semirigid ice control structures.

Type of structure	Fig. no.	General function*	Water body	Material	Dimensions (m)	Force level† (kN/m)
<b>Booms</b>						
Floating (pier-mounted)	12	icfs, ijr	St. Lawrence R.	Steel pontoons; concrete piers	1.7x1.83x25 (pontoons)	73 <sup>d</sup> (pontoons); 146 (piers)
Fixed	13	icr	Tungnaa R.	Reinforced concrete	5.5 (height w/flash boards) x2.5x110	146 <sup>d</sup> ; 890-kN centerload
	14	ir, d	Tungnaa R.	Reinforced concrete	8x6x60	59 <sup>d</sup>
<b>Border ice bridge</b>		icfs	Dvina R.	Ice	≤ 200	Unknown
<b>Artificial islands</b>						
Low	18b	icfs, n	St. Lawrence R.; Lake St. Peter	Stone; glacial till (0.6-1.1 m diam)	10.4 (diam at water line); ~79 (diam at base); 2.5 (height above LWL)	Unknown
High	18a	icfs, n	St. Lawrence R.; Lake St. Peter	Stone; glacial till	10.7 (diam at water line); ~74.4 (diam at base); 4.3 (height above LWL)	Unknown
	19	icfs, n	St. Lawrence R.; Lake St. Louis	Quarry stone; armor stone	Square: 11.8 (length of side at water line); 35 (length of side at base); 5.8 (height)	Unknown
<b>Light tower bases</b>						
	22	icfs, n	St. Lawrence R.	Timber cribs & piles	Square: 7.5 (length of side)	1495 <sup>d</sup>
	28	icfs, n	Lake St. Peter	Concrete & steel piles	Conical: 2.4 (diam at top); 45° incline	1.38-1.72 <sup>d</sup> MPa
	29	n	Lake St. Clair	Steel shell & piles; concrete cap	5.4 (diam at top); 10.9 (diam at base)	1.38-1.72 <sup>d</sup> MPa
	30	n	Lake Erie	Steel	Square: 0.36 (length of side)	5.52 MPa <sup>d</sup> with 0.51-m ice
<b>Groins</b>						
	16	icfs, p	Pasvik R.	Stone	Unknown	Unknown
	15	icfs, p	Burntwood R.	Stone; earth	9.1 (max.ht); 274 (length); 0.9-1.2 (diam of nose armor boulders)	Unknown
<b>Timber cribs</b>	21	icr	Narraguagus R.	Timbers; stone	4.2(length)x2.4(width)x4.9 (height); 0.5 slope on face	73 <sup>d</sup>
<b>Rock-filled scow</b>	20	icr	St. Marys R.	Steel; stone	7.3x24.4	50 <sup>c</sup>
<b>Crane weights</b>		icr	St. Marys R.	Reinforced concrete	3.3x3.3x3.7; stack of six weights	59 <sup>c</sup>
<b>Weirs</b>						
	23	icfs	Small streams	Logs; steel	30-61 (pool length)	Hydrostatic pressure
	24	icfs, x	Israel R.	Stone; gabion basket	2(height)x51.8(length)	87.6 at crest <sup>n</sup>
<b>Weir and grating</b>	26	icfs	Chaudiere R.	Concrete piers; steel grill	12.8(height)x190(length)	Unknown

\* icfs = ice cover formation and stabilization

ijr = ice jam reduction

icr = ice cover retention

ir = ice retention

d = shear or diversion

n = navigation

p = hydroelectric power

x = experimental

† d = design criterion

c = estimated

Water depth (m)	Avg. water velocity (m/s)	Organization	References	Notes
6.7	≤1.83	Canadian Coast Guard, Ministry of Transport, Montreal	Lawrie (1972), Stothart & Croteau (1965)	A few pontoons were broken by ice impact
6-6.5	≤5	Landsvirkjun (National Power Co.), Reykjavik, Iceland	Eliasson (pers. comm.)	Reservoir overflow spillway
7-9	Unknown	Landsvirkjun (National Power Co.), Reykjavik, Iceland	Freysteinnsson (pers. comm.)	Power canal inlet
"deep"	"quiet"		Kanavin (1944), Bolsenga (1968)	Reinforced with wire at times
2.7-5.2	0.3-0.5	Canadian Coast Guard, Ministry of Transport, Ottawa	Danys (1975)	
6.4-7.6	0.3-0.5	Canadian Coast Guard, Ministry of Transport, Ottawa	Danys (1975)	
4.4	Unknown	Seaway Transport Canada, Cornwall, Ontario	Graham (pers. comm.)	Undergoing evaluation
1.8	Unknown	Canadian Coast Guard, Ministry of Transport, Ottawa	Danys (1977)	Replacement for failed structure
2.0	0.3-0.5	Canadian Coast Guard, Ministry of Transport, Ottawa	Danys (1977)	No failure
5.5	~0	U.S. Coast Guard, Cleveland, Ohio	Schnappinger (pers. comm.)	
3	~0	U.S. Coast Guard, Cleveland, Ohio	Schnappinger (pers. comm.)	
Unknown	Unknown	Water Resources & Electricity Board, Oslo, Norway	Kanavin (1970)	
7.0	≤5	Manitoba Hydro, Winnipeg	Janzen & Kuluk (1979)	Flow increased by river diversion; ice boom also used
2.3	0.3	New England Division, U.S. Army Corps of Engineers	U.S. Army Corps of Engineers (1960)	Also 2.1-m-high weir; three cribs
1.8	0.5	Detroit District, U.S. Army Corps of Engineers	U.S. Army Corps of Engineers (1979)	Supplemental anchors
1.8	0.5	Detroit District, U.S. Army Corps of Engineers	U.S. Army Corps of Engineers (1979)	Supplemental to scow
1.5	Unknown	Bureau of Reclamation, Engineering & Research Center, Denver	Hayes (1974)	
2.1 pool	<0.1 in pool	New England Division, U.S. Army Corps of Engineers	Manley (pers. comm.)	Local protection project
8.3	Unknown	Quebec Ministry of Natural Resources, St. Georges, Quebec	Deslauriers et al. (1965)	

A facsimile catalog card in Library of Congress MARC format is reproduced below.

Perham, Roscoe E.

Ice sheet retention structures / by Roscoe E. Perham. Hanover, N.H.: U.S. Cold Regions Research and Engineering Laboratory; Springfield, Va.: available from National Technical Information Service, 1983.

iv, 39 p., illus.; 28 cm. ( CRREL Report 83-30. )

Prepared for the Office of the Chief of Engineers by Corps of Engineers, U.S. Army Cold Regions Research and Engineering Laboratory under CWIS 31725.

Bibliography: p. 27.

1. Ice control structures. 2. Ice sheets. 3. Ice retention. I. United States. Army. Corps of Engineers. II. Cold Regions Research and Engineering Laboratory, Hanover, N.H. III. Series: CRREL Report 83-30.

FILM  
4-8