

AD-A138 047

REDESIGNED OF T-38 DISPLACEMENT GYROSCOPE PACK(U) AIR  
FORCE PACKAGING EVALUATION AGENCY WRIGHT-PATTERSON AFB  
OH MATERIALS ENGINEERING BRANCH A J SICARD JAN 84  
DSTZT-83-R-11

1/1

UNCLASSIFIED

F/G 11/4

NL



END  
COUNT  
34  
11/84

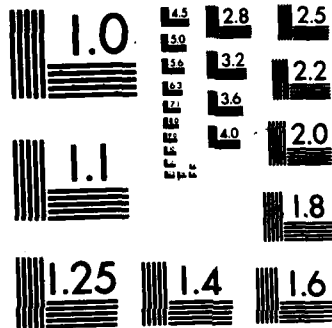

MICROCOPY RESOLUTION TEST CHART  
NATIONAL BUREAU OF STANDARDS-1963-A

✓ (12)

APPROVED FOR PUBLIC RELEASE  
DISTRIBUTION UNLIMITED

DSTZT-Report No. 83-R-11  
AFPEA Project No. 80-P7-17

AD A138047

ALFRED J. SICARD

Mechanical Engineering Technician  
Materials Engineering Branch ✓  
HQ AFLC/DSTZT

AUTOVON 787-4519  
COMMERCIAL (513) 257-4519

4

REDESIGNED OF T-38 DISPLACEMENT  
GYROSCOPE PACK

DTIC  
ELECTE  
FEB 21 1984  
S A

HQ AFLC/DSTZ ✓  
AIR FORCE PACKAGING EVALUATION AGENCY  
WRIGHT-PATTERSON AFB OH 45433

January 1984

DTIC FILE COPY

84 02 21 003

**NOTICE**

When government drawings, specifications, or other data are used for any purpose other than in connection with a definitely related government procurement operation, the United States Government thereby incurs no responsibility whatsoever; and the fact that the government may have formulated, furnished, or in any way supplied the said drawings, specifications, or other data, is not to be regarded by implication or otherwise as in any manner licensing the holder or any other person or corporation, or conveying any rights or permission to manufacture, use, or sell any patented invention that may in any way be related thereto. This report is not to be used in whole or in part for advertising or sales purposes.

AFPEA PROJECT NO.: 80-P7-17

PROJECT TITLE: Redesigned of T-38 Displacement Gyroscope Pack

PROJECT MONITOR: Alfred J. Sicard

**ABSTRACT**

In support of the Aerospace Guidance and Metrology Center (AGMC) Ohio, the Air Force Packaging Evaluation Agency redesigned the T-38, 19005 gyroscope displacement pack (TPO-00-077-3218) reducing its cubage by 48% and tare weight by 51%. In addition, fabrication material was reduced by 62% and the new pack design provided for ease of packing and unpacking the gyroscope while maintaining the 15G item fragility protection level. A formal report including drawings, parts breakdown and test data was coordinated with the lead service activity, Oklahoma City Air Logistics Center, (OC-ALC/DSTP). It was recommended that the redesigned pack be considered as a replacement to the current pack in the packing of gyroscope models 2A and 2B.



SEARCHED  
SERIALIZED  
INDEXED  
FILED  
JAN 23 1984  
AFPEA

A-1

PREPARED BY:

*Alfred J. Sicard*

ALFRED J. SICARD  
Mechanical Engineering Technician  
AF Packaging Evaluation Agency

PUBLICATION DATE:

23 JAN 1984

REVIEWED BY:

*Matthew A. Venetos*

MATTHEW A. VENETOS  
Chief, Materials Engineering Branch  
AF Packaging Evaluation Agency

APPROVED BY:

*Jack E. Thompson*

JACK E. THOMPSON  
Director, Air Force Packaging  
Evaluation Agency

TABLE OF CONTENTS

	<u>PAGE</u>
Abstract . . . . .	i
Table of Contents . . . . .	ii-iii
Introduction . . . . .	1
Approach . . . . .	1
Description of Packs . . . . .	1
Test Load . . . . .	1
Instrumentation and Equipment . . . . .	2
Test Procedures/Results . . . . .	2
Free Fall Drop Test . . . . .	2
Vibration Test . . . . .	2
Results . . . . .	2-3
Discussion . . . . .	3
Conclusion . . . . .	3
Recommendation . . . . .	3

FIGURES

Figure 1 - Pictorial of Redesigned Pack . . . . .	4
Figure 2 - Redesigned Pack, Outer Container & Inner Cushioned Pack . . . . .	5
Figure 3 - T-38 Gyro and Simulated Test Load . . . . .	5
Figure 4 - Current Pack Components . . . . .	6
Figure 5 - Redesigned Pack Components . . . . .	6
Figure 6 - Packing Configuration of Current Pack . . . . .	7
Figure 7 - Packing Configuration of Redesigned Pack . . . . .	7
Figure 8 - Acceleration Time Curves . . . . .	8

TABLES

Table I - Parts Breakdown of Current & Redesigned Pack . . . . .	9
Table II - Drop Test Data - Redesigned Pack . . . . .	10

TABLE OF CONTENTS (CONT)

	<u>PAGE</u>
Transportation Pack Order TPO-00-077-3218 . . . . .	11-12
Report Documentation Page . . . . .	13
Distribution List . . . . .	14

## INTRODUCTION

In support of AGMC, Preservation and Packaging Branch, 2803 ABG/DMTP, Newark AFS, Ohio, this agency conducted an evaluation of the T-38, 19005, (2A) and (2B) displacement gyroscope pack to determine if the current design could be improved by reducing its volume, weight and numerous parts, while maintaining the required 15G protection level. Also, consideration was given to remedy a deficiency regarding a packing and unpacking problem encountered with the gyroscope in the current pack cited in a Product Quality Audit Report released by AGMC Quality Assurance.

## APPROACH

The following design objectives were used in developing the redesigned pack:

1. The pack will provide the preservation and packaging levels specified in TPO-00-077-3218, as well as provide the 15G item fragility protection level under normal shipping, handling and storage environments.
2. The pack will be configured for ease of packing and unpacking the gyro by its handle.
3. The pack cube and tare weight will be kept to a minimum.
4. The pack design will be kept simple, using only essential parts, standard packaging materials and a construction method which involves no complex cutting or difficulty in parts assembly.
5. Overall, the pack should enhance packaging economy while providing *maximum protection*.

## DESCRIPTION OF PACKS

The current pack consists of a reuseable doublewall fiberboard container (I.D. 27" x 27" x 28"), two inner fiberboard containers (one the item box), cushioned by six polyurethane foam pads. Numerous other parts, i.e., fiberboard pads, sleeves, spacers and dunnage are employed to accommodate the gyroscope. Packaging and preservation requirements are specified as level A and C, in accordance with MIL-P-116. Details of the current pack are shown in TPO-00-077-3218, Appendix A, and in Figure 4.

The redesigned pack consists of a reuseable doublewall fiberboard container (I.D. 22 5/8" x 20 5/8" x 22 5/8"), one inner item box and six polyurethane foam pads. Polyethylene pads are used to brace the gyroscope within the item box. Packaging and preservation levels are equivalent to the current pack. Details of this pack are shown in Figures 1 and 2.

## TEST LOAD

A laminated plywood test load measuring 12 1/2" x 6 1/4" x 6 1/4" and weighing 31 1/4 lbs was used to simulate the T-38 displacement gyroscope; three triaxially mounted accelerometers were located at the center of gravity for measuring the peak acceleration. A non-operating T-38 displacement gyroscope was used in designing the pack configuration for ease of removing the gyro by its handle. The T-38 gyro and test load are shown in Figure 3.

## INSTRUMENTATION AND EQUIPMENT

The following instrumentation and equipment were employed in this study:

1. Oscilloscope, 4 channel storage, Tektronix model 564-B.
2. Accelerometer, tri-axial, Endevco, Model 2228C S/N CM55.
3. Amplifier (3 each), Endevco, Model 2614C.
4. Power Supply, Endevco, Model 2622C.
5. Gaynes, Drop Tester, Model 125.
6. L.A.B. Drop Tester, Model 50-100.
7. L.A.B. Vibration Tester, Model 5000-96B.

## TEST PROCEDURES/RESULTS

### Free Fall Drop Test:

The redesigned pack was subjected to a 25 inch free fall drop test (Level A) in accordance with Federal Test Method Standard (FTMS) 101C, Method 5007.1, Procedure B, and in addition four diagonally opposite corner drops and four diagonally opposite edge drops. A tri-axial accelerometer was mounted at the center of gravity of the test load to record impact shock (Gs). Following each series of flat, edge and corner drops, the outer container was opened to determine whether the inner container and attached polyurethane cushioning pads remained in place or had rotated. The results of the drop test are presented in Table II.

### Vibration Test:

The redesigned pack was subjected to a two hour vibration repetitive shock test in accordance with Method 5019.1 of FTMS 101C. The primary purpose of this test was to evaluate the ability of the inner container to remain in place and to determine the durability of the cushioning pads in resisting deterioration to their dynamic cushioning properties after repeated shock/vibration.

## RESULTS

Compared to the current pack, the redesigned pack is 48% smaller in cube, 51% lighter in tare weight, has six fewer parts (notably one inner container rather than two) and saves 62% square footage of construction material.

The drop test results for the redesigned pack were below the 15G fragility rating of the gyroscope; the highest shock value recorded was 14.8Gs during the flat drop on the container side face #2. After completion of the flat drop series, inspection within the pack revealed that the inner load sloped one inch from the top surface of the outer container. However, further flat drops while leaving the inner pack in this position didn't exceed 15Gs. Figure 8 depicts acceleration time curves of a typical flat, edge and corner drop. Following completion of the shock and vibration tests,

inspection within the pack revealed all parts were properly aligned. Additional flat drops performed on the faces of the pack were satisfactorily monitored below 15Gs, without any evidence of deterioration in the cushioning pads' performance. Also, no apparent load shift or rotation occurred within the inner container.

### DISCUSSION

Evaluation of the current pack resulted in the following findings:

1. The size and weight of the pack was far in excess of that required for the 15G fragility level of the gyro.
2. A second inner container, in place of blocking material to brace the gyro, was considered unnecessary.
3. Numerous parts such as sleeves, cutout plates, dunnage, spacers, and two inner containers rather than one significantly increase material usage, weight and cube which directly increases fabrication and shipping cost.
4. No access provided to the gyro handle or hand space to grip the gyro by its casing for ease of unpacking.

Prior to finalizing the configuration of the redesigned pack, other pack designs including corner pads as well as complete encapsulation were considered using the agency's computer program for packaging cushioning design. Promising candidate designs identified with this program, which included various types and grades of cushioning materials, were subjected to drop testing. However, those packs tested either failed to meet the design objectives or didn't performed as well as the redesigned pack. The problem encountered with the complete encapsulation pack designs during drop tests were unusually high peak Gs (above 24) which were much higher than those based on the computer program analysis. This difference was found to be caused by cushion pad size effects, e.g., the unpredictiveness of a pad's dynamic cushioning performance when its surface extends beyond the impact surface of the load. Possible alleviation of this problem would have involved extensive stress relief cutting of the cushioning and/or an increase in the thickness of the pads. The problem encountered with the use of corner pad designs was excessive rotation and wedging of the inner container during the drop test. As a result, peak shocks between 20 to 30 G's occurred prior to completing the required number of drops.

To minimize pilferage and to insure proper packaging of the gyro, permanently glued and hinged parts were incorporated into the design of the new pack. Also, standard packaging materials involving no complex cutting or difficulty in fabrication were used to make up the new pack assembly.

### CONCLUSION

The redesigned pack will provide a 15G protection level as well as preservation and packaging protection equivalent to that specified in TPO-00-077-3218.

### RECOMMENDATION

Recommend that the redesigned pack be adopted as a replacement to the current pack for packaging of gyro models 2A and 2B.

T-38 Gyro  
Displacement Case  
WT 31 1/2 lbs  
Size 6 1/4" x 6 1/4" x 12 1/4"

Item #13 or 14  
Polyethylene Wrap  
(L-P-378) or Bag  
(MIL-B-117)

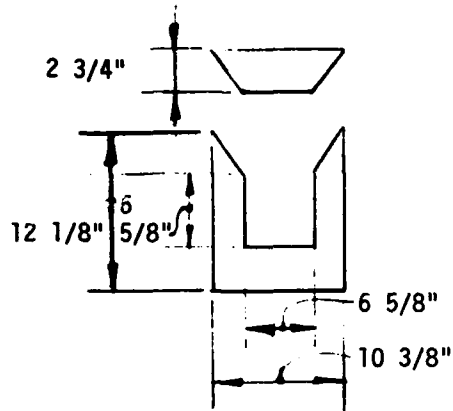

**DETAIL-1**

Item #4, Polyurethane  
Cushioning Pads, (6 EA),  
12" x 12" x 5", Type I,  
Class 2, Grade B,  
IAW MIL-P-26514E,  
Glued To Carton  
Surfaces

Item #15  
Gyro Bracing Forms,  
Glued Within And On  
The Flap Of Carton.  
2" TH, Type I, 2 lb  
Density, Polyethylene  
Foam, (PPP-C-1752)  
See Detail-1 For  
Dimensions.

Item #6, Modified  
RSC F/B Carton,  
I.D. 12 3/8" x 10 3/8" x 12 1/8",  
Full Overlap Flaps  
(Top End Only) S.W.  
V3C.

Item #1, RSC  
F/B Container,  
I.D. 22 5/8" x 20 5/8" x  
22 5/8", D.W. V11C

Gross Cube: 6.54 cu. ft.  
Gross Wt: 48 lbs  
Protection Level: 15 Gs (Level A)

**NOTES:**

1. + 1/16" Tolerance.
2. 3M (74) Foam & Fabric Adhesive Recommended Or Its Equal.

**FIGURE 1**

SKETCH-1: Proposed Redesigned T-38 Gyro Displacement Pack (Ref. TPO-00-077-3218, OC-ALC/DSP).

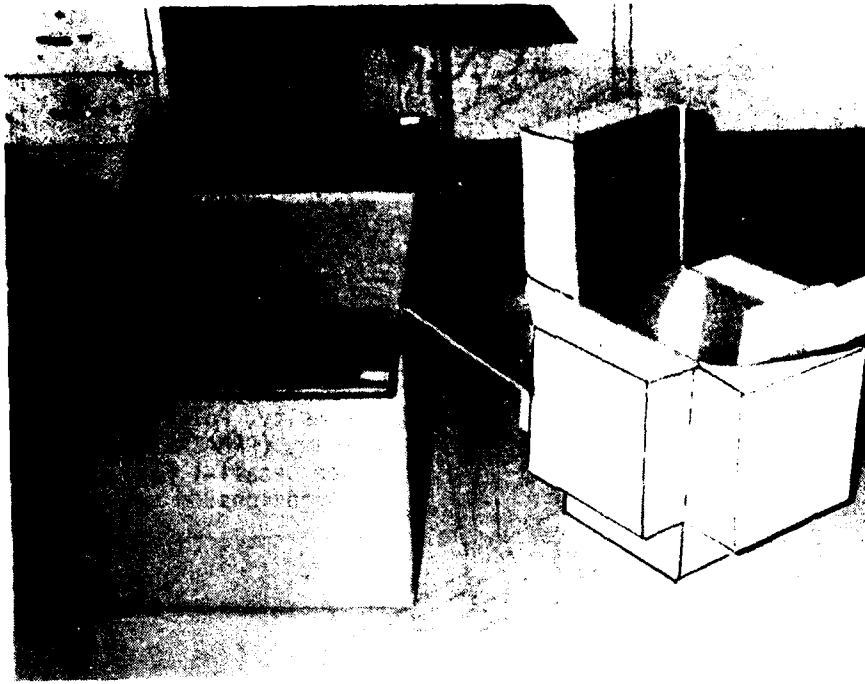

FIGURE - 2  
Redesigned Pack,  
Outer Container and  
Inner Cushioned Pack



FIGURE - 3  
T-38 Gyro and  
Simulated Test  
Load

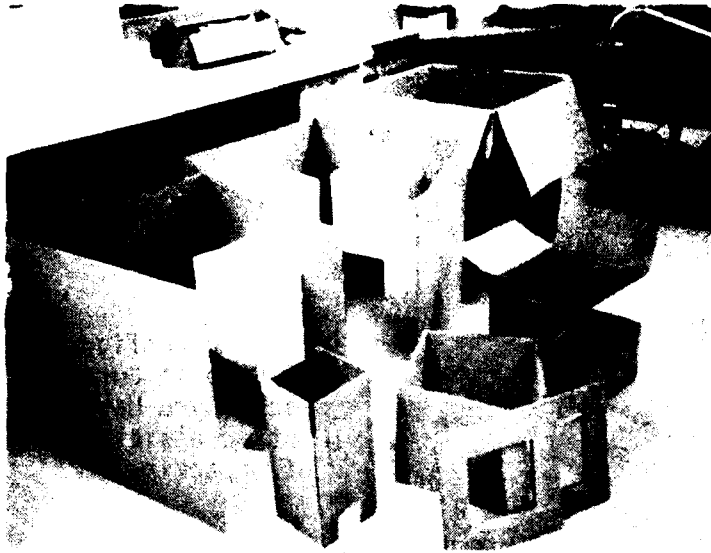

FIGURE - 4  
Current Pack Components

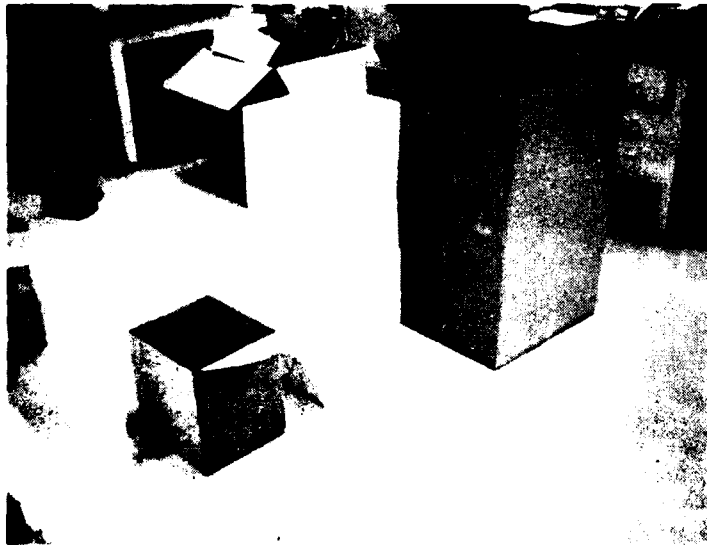

FIGURE - 5  
Redesigned Pack Components

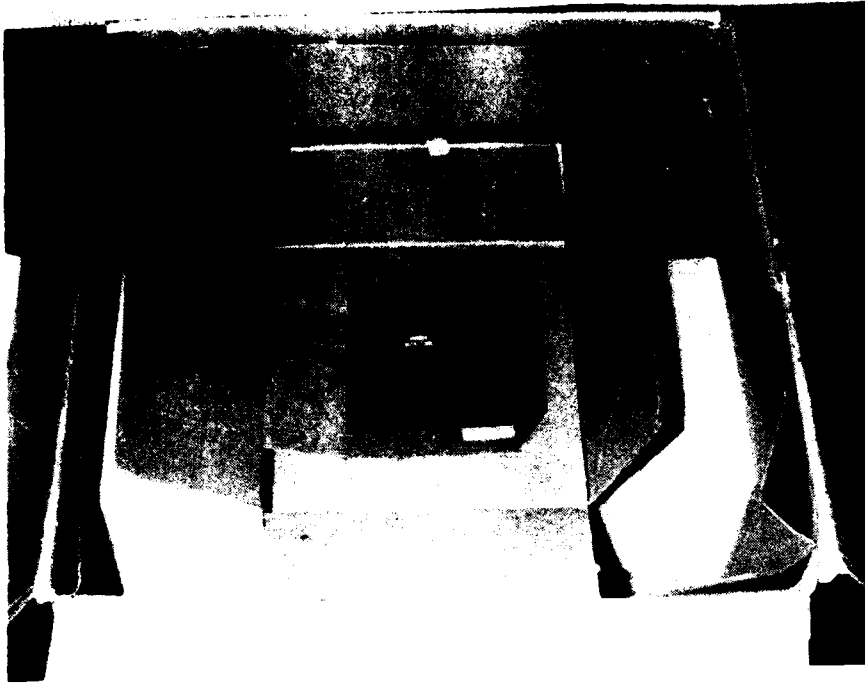

FIGURE - 6  
Packing Configuration  
of Gyro in Current  
Pack (Gyro Handle is  
not Accessible for Ease  
of Unpacking)

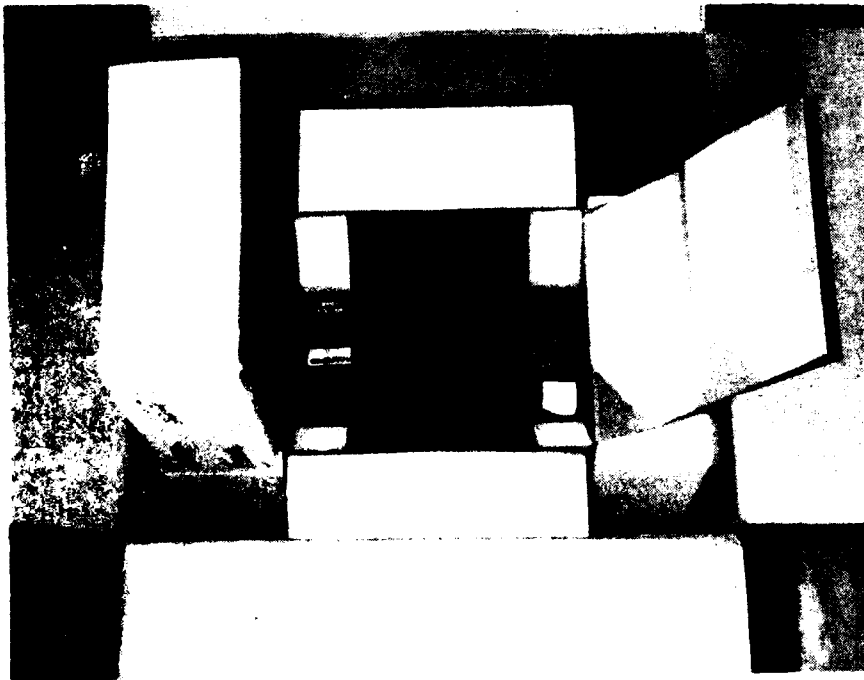
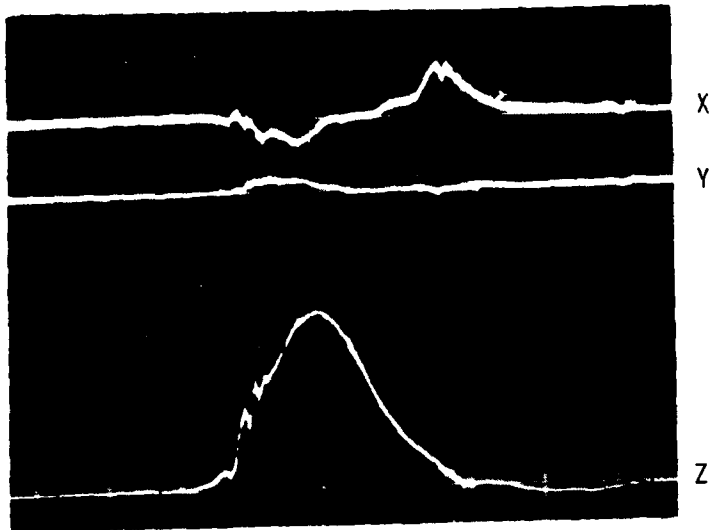

FIGURE - 7  
Packing Configuration of  
Gyro in Redesigned Pack  
(Gyro Handle is Accessible  
for Ease of Unpacking)



FLAT DROP, SIDE #1

AMPLITUDE: 5Gs/Div  
 TIME BASE: 20 MSEC/DIV

NOTE: See Table II For Complete Drop Test Data.

<u>X</u>	<u>Y</u>	<u>Z</u>	<u>RESULTANT</u>
1.3	0.5	12.0	12.1Gs

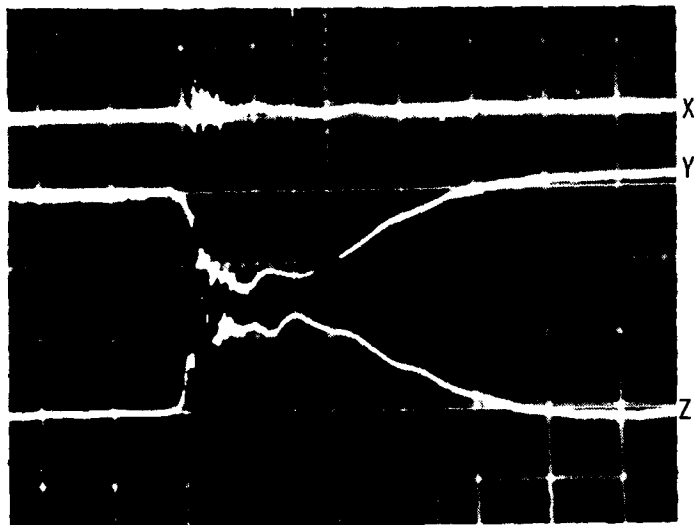

EDGE DROP, 1-4

<u>X</u>	<u>Y</u>	<u>Z</u>	<u>RESULTANT</u>
0	5.7	6.5	8.6Gs

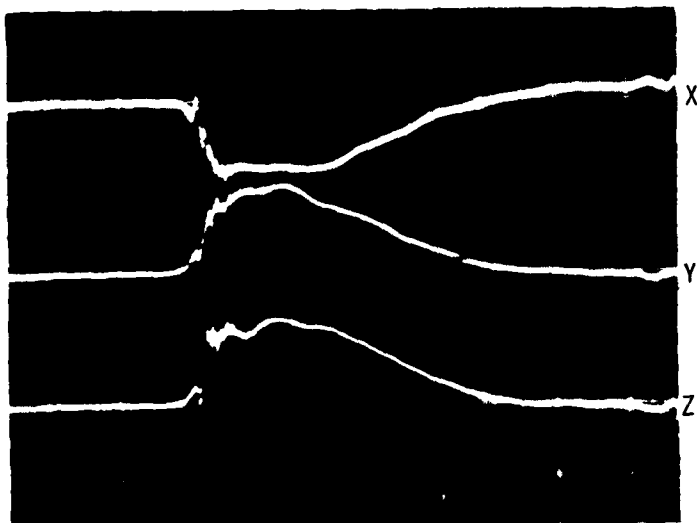

CORNER DROP 1-2-5

<u>X</u>	<u>Y</u>	<u>Z</u>	<u>RESULTANT</u>
4.7	6.0	6.0	9.7Gs

FIGURE 8: ACCELERATION TIME CURVES

<u>ITEM</u>	<u>CURRENT PACK</u>	<u>REDESIGNED PACK</u>
1. Outer F/B Container	I.D. 27" x 27" x 28"	I.D. 22 5/8" x 20 5/8" x 22 5/8"
2. Lower F/B Sleeve	1/8" x 27" x 82 3/4"	Not Required
3. Upper F/B Sleeve	1/8" x 26 3/4" x 109 3/4"	Not Required
4. Polyurethane Pads	7" x 12" x 12" (6 ea)	5" x 12" x 12" (6 ea)
5. Adhesive	As Required	3M Fabric and Foam Spray (74)
6. F/B Carton	I.D. 13" x 13" x 14"	I.D. 12 3/8" x 10 3/8" x 12 1/8"
7. F/B Inserts	9/16" x 13" x 13" (2 ea)	Not Required
8. F/B Liner	9/16" x 13" x 50 3/4"	Not Required
9. Tape	As Required	As Required
10. F/B Carton	I.D. 7" x 7" x 13 1/2"	Not Required
11. Bottom Cushion	2" x 7" x 7"	Not Required
12. Filler	As Required	Not Required
13. Wrap (L-P-378)	As Required	As Required
14. Bag (M-B-117)	27" x 30" (For Box)	16" x 13" (For Gyro)
15. Bracing Forms	N/A	12 1/8" x 10 3/8" x 2" (2 ea)

**NOTES:**

Pack (Gross Wt)	65 lbs	48 lbs
Pack (Parts)	19 ea	13 ea

TABLE I: Parts Breakdown of Current & Redesigned Packs

PEAK ACCELERATION (Gs)

<u>IMPACT SURFACE</u>	<u>X</u>	<u>Y</u>	<u>Z</u>	<u>(R)</u>	<u>DURATION MSEC</u>
3 (Bottom)	1.2	0	12.5	12.6	76
1 (Top)	1.3	0.5	12.0	12.1	78
2 (Front)	1.0	14.8	0.4	14.8	66
4 (Back)	2.5	13.0	1.0	13.3	72
5 (L. Side)	10.0	0.5	2.0	10.2	70
6 (R. Side)	10.0	1.3	1.0	10.1	76
(Edges)					
1-4	0	5.7	6.5	8.6	94
2-3	0.5	6.0	7.0	9.2	92
1-5	6.0	0.5	6.0	8.5	95
3-6	5.8	0	6.8	8.9	90
(Corners)					
1-4-5	4.7	4.0	5.0	7.9	88
2-3-6	5.0	6.0	5.0	9.3	92
1-2-5	4.7	6.0	6.0	9.7	92
3-4-6	4.0	6.0	5.0	8.8	92
2 (Front) <sup>1</sup>	0.5	12.0	4.7	12.9	92
4 (Back) <sup>1</sup>	3.2	10.0	1.2	10.6	80

NOTES:

1. Additional drops were made on surfaces 2 and 4 to check for possible peak acceleration resultants that might exceed 15Gs.
2. The drop test was performed in accordance with Method 5007-1, procedures B, C, & D, 25" drops of FTMS 101C.

TABLE II: Drop Test Data of Redesigned TPO T-38 Gyro Pack



2 TPO NO. 00-077-3218

TABLE NUMBER ONE

NATIONAL STOCK NUMBER CONTRS PART NUMBER

**NOTES**

- ① MAT'L REQ'TS. FOR PARTS ② & ③ TO BE: TYPE - CF, CL - DOM, VAR. - SW, GR. - 200 PSI.
- ② MAT'L REQ'TS. FOR PARTS ④ & ⑤ TO BE: POLYURETHANE (ETHER) FOAM, TYPE - 1, CL - 2, GR. - B, DENS. PER CU. FT. FOR PART ④, 1.4; FOR PART ⑤, 1.6 PER CU. FT.
- ③ MAT'L REQ'TS. FOR CARTONS ⑥ & ⑦ TO BE: STYLE - 2 SC, TYPE - CF, CL - DOM, VAR. - SW, GR. - 200 PSI.
- ④ MAT'L REQ'TS. FOR PARTS ⑧ & ⑨ TO BE: TYPE - CF, CL - DOM, VAR. - TW, GR. - 1100 PSI.
- ⑤ LAMINATE & BOND SLEEVE & CUSHION ASSEMBLIES TOGETHER & IN POSITION WITH ADHESIVE ⑥, OR EQUAL.
- ⑥ ARROW → INDICATES DIRECTION OF FLUTE CORREGATIONS.

⑦ FOLD HANDLE OF ITEM DOWN FOR PACKAGING. WRAP ITEM WITH PART ⑧ AND FILL VOIDS BETWEEN ITEM AND CARTON ⑨ WITH CUSHIONING ⑩.

00748 20-077-3218

6c. ADDRESS (City, State and ZIP Code)  Wright-Patterson AFB, Ohio 45433			7b. ADDRESS (City, State and ZIP Code)  None			
8a. NAME OF FUNDING/SPONSORING ORGANIZATION  None		8b. OFFICE SYMBOL (If applicable)	9. PROCUREMENT INSTRUMENT IDENTIFICATION NUMBER  None			
8c. ADDRESS (City, State and ZIP Code)			10. SOURCE OF FUNDING NOS. None			
			PROGRAM ELEMENT NO.	PROJECT NO.	TASK NO.	WORK UNIT NO.
11. TITLE (Include Security Classification) Proposed Redesign of 19005 (2A) & (2B) Displacement Gyroscope Pack			T-38	TPO-00-077-3218		
12. PERSONAL AUTHOR(S) Alfred J. Sicard						
13a. TYPE OF REPORT FINAL		13b. TIME COVERED FROM 80/1/30 TO 1/3/84		14. DATE OF REPORT (Yr., Mo., Day) 84 January		15. PAGE COUNT 18
16. SUPPLEMENTARY NOTATION  None						
17. COSATI CODES			18. SUBJECT TERMS (Continue on reverse if necessary and identify by block number)			
FIELD	GROUP	SUB. GR.	Pack, T-38 Gyro, Drop Test, Packaging, Polyurethane Cushion, Fiberboard, Container			
19. ABSTRACT (Continue on reverse if necessary and identify by block number)  In support of AGMC, Newark AFS, this agency redesigned the T-38, 19005 Gyroscope Displacement Pack (TPO-00-077-3218) reducing its cube by 48 percent and tare weight by 51 percent. The new pack design provided for ease of packing and unpacking the gyroscope while maintaining the 15G item fragility protection level. It was recommended that the redesigned pack be considered as a replacement to the current pack in the packing of gyroscope model 2A and 2B.						

DISTRIBUTION LIST

HQ AFLC/DSTZ/DSTZT WPAFB OH 45433	1	AFPRO/PD General Dynamics P.O. Box 371	
AFALC/PTPP WPAFB OH 45433	3	Attn: Rick Stenzil Ft Worth Division Ft Worth TX 76101	1
HQ AFLC/DSTZT Library WPAFB OH 45433	20	AFPRO/PD (Packaging Engineer) Westinghouse Defense & Electronic System Center P.O. Box 1693 Baltimore MD 21203	1
HQ AFLC/DSTP WPAFB OH 45433	1		
AGMC/QA Newark AFS OH 43055	1	HQ AFSC/LGT Scott AFB IL 62225	1
2803 ABG/DMTP Newark AFS OH 43055	1		
HQ USAF/LETT WASH DC 20330	1	ASO/TEE/TEP-A 4030 700 Robbins Avenue Philadelphia PA 19111	1
OC-ALC/DSTD Tinker AFB OK 73145	1	Aviation Supply Office Attn: Engineering Division 700 Robbins Avenue Philadelphia PA 19111	1
OC-ALC/MMIR Tinker AFB OK 73145	1		
OO-ALC/DSTD Hill AFB UT 84056	1	DARCOM Packaging & Storage & Container Center Attn: SDSTO-T Tobyhanna PA 18466	1
OO-ALC/DSTD Attn: Robert Sorensen Hill AFB UT 84056	1	DESC-T 1507 Wilmington Pike Dayton OH 45444	1
SA-ALC/DSTD Kelly AFB TX 78241	1		
SM-ALC/DSTD McClellan AFB CA 95652	1	DLSIE/DRXMC-D U.S. Army Logistics Management Attn: Mr. Malcom Alley Fort Lee VA 23801	1
WR-ALC/DSTD Robins AFB GA 31098	1	DTIC/TSR Cameron Station Alexandria VA 22314	12
ADTC/SD3P Eglin AFB FL 32542	1	ESD/TOSM Hanscom AFB MA 01731	1
AFCMD/PDT Attn: Jim Rorie Kirtland AFB NM 87115	1	GSA Office of Engineering Management Packaging Division WASH DC 20406	1

FILM  
3-8