

AD-A138 111

UPGRADE VERIFICATION AND DOCUMENTATION OF  
1923 TIME SERIES SYSTEM(U) AIR FORCE INST  
WRIGHT-PATTERSON AFB OH SCHOOL OF ENGI..

GENERAL RADIO  
OF TECH  
B A CASELLA  
F/G 9/2

1/2

UNCLASSIFIED

NL

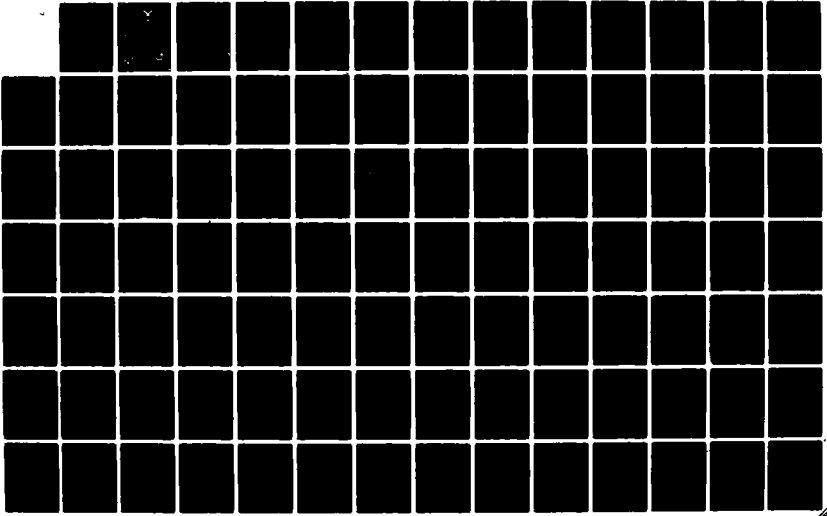

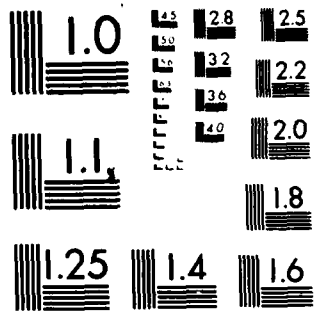

MICROCOPY RESOLUTION TEST CHART  
NATIONAL BUREAU OF STANDARDS-1963-A

AD A138111



UPGRADE, VERIFICATION, AND DOCUMENTATION  
 OF GENERAL RADIO 1923 TIME SERIES SYSTEM

THESIS

AFIT/GE/EE/83D-15

Bruce A. Casella  
 CAPT USA

This document has been approved  
 for public release and sale; its  
 distribution is unlimited.

DTIC  
 ELE.  
 FEB 22 1984  
 S  
 A

ERIC FILE COPY

DEPARTMENT OF THE AIR FORCE  
 AIR UNIVERSITY  
**AIR FORCE INSTITUTE OF TECHNOLOGY**

Wright-Patterson Air Force Base, Ohio

84 02 22 078

AFIT/GE/EE/83D-15

UPGRADE, VERIFICATION, AND DOCUMENTATION  
OF GENERAL RADIO 1923 TIME SERIES SYSTEM

THESIS

AFIT/GE/EE/83D-15

Bruce A. Casella  
CAPT USA

RECEIVED  
22 2 1984

A

Approved for public release; distribution unlimited.

AFIT/GE/EE/83D-15

UPGRADE, VERIFICATION, AND DOCUMENTATION  
OF GENERAL RADIO 1923 TIME SERIES SYSTEM

THESIS

Presented to the Faculty of the School of Engineering  
of the Air Force Institute of Technology  
Air University  
in Partial Fulfillment of the  
Requirements for the Degree of  
Master of Science

by

Bruce A. Casella

CAPT USA

Graduate Electrical Engineering

December 1983

Approved For	
CLASS	
GROUP	
EXPIRATION	
/	
DATE	
BY	
A-1	



Approved for public release; distribution unlimited.

### Acknowledgements

I would like to thank my advisor, Major Kenneth G. Castor of the Air Force Institute of Technology, for proposing this thesis topic.

I am also grateful to Dr. Vaqar H. Syed for his assistance on the thesis effort.

Special thanks is extended to Mr. Dan Zambon for his continuing efforts to assist and advise on all facets of the project.

A very strong debt of gratitude is also owed to Mr. Al D. Luebbers, Senior Field Service Engineer, GENRAD Vibrations Analysis Division, for his assistance and efforts to make the thesis project a success.

Finally, I want to express my appreciation to my wife, Cathie, for her encouragement throughout the thesis effort.

Bruce A. Casella

## CONTENTS

	<u>PAGE</u>
Acknowledgements . . . . .	ii
List of Figures . . . . .	iv
List of Tables . . . . .	v
Abstract . . . . .	vi
I. Introduction . . . . .	1
II. Overview of 1923/30 Time-Series Analysis System	
General System Description . . . . .	7
Physical Description of System	
Components . . . . .	8
Functional Description of System	
Components . . . . .	20
System Software Programs . . . . .	31
III. Upgrade Procedures for 1923/30 System	
General Approach . . . . .	43
Installation of Heathkit H-19A CRT . . . . .	43
Reconfiguration of PDP-11/15 UNIBUS	
Structure . . . . .	46
Verification of TTY/SPC Backplane wiring . . . . .	49
RX02 Disk Drive Interface . . . . .	56
Installation of KF11-A Multiple Bus	
Priority Module . . . . .	59
Installation of KW11-L Line Time Clock . . . . .	67
Modification/Installation of DD11-A	
Module . . . . .	69
Installation of M8256 Controller Module . . . . .	71
Installation/Operation of Software	
Operating System . . . . .	73
Installation of M9312 Bootstrap	
Module . . . . .	75
IV. Tests and Analysis	
Heathkit H-19A CRT Tests . . . . .	79
DEC RT.11 Bootstrap Tests . . . . .	79
Diagnostic Tests . . . . .	82
V. Conclusions and Recommendations . . . . .	89
Bibliography . . . . .	92

LIST OF FIGURES

<u>FIGURE</u>		<u>PAGE</u>
1	1923/30 System Rack Configuration . . . . .	10
2	PDP-11/15 Box Configuration . . . . .	12
3	BB-11/DD-11A Module Layout . . . . .	11
4	Simplified UNIBUS Block Diagram . . . . .	13
5	Analog Input/Output Connectors on Control Unit . . . . .	25
6	Simplified 1923/30 System Structure . . . . .	48
7	Complete Configuration for 1923/30 System . .	50
8	UNIBUS Pin Configurations . . . . .	52
9	Priority Jumper Plug for TTY . . . . .	55
10	TTY/SPC Input and Output Signals on Backplane . . . . .	57
11	TTY/SPC Internal Jumpers on Backplane . . . .	58
12	Bus Request Circuitry for M7218 Multiple Bus Priority Module . . . . .	61
13	J2/J3 Jumpers for M7216 Priority/Control Module . . . . .	63
14	IC Position Numbers for M7218 Module . . . .	66
15	Wiring Modifications for Installation of KW11-L Time Line Clock . . . . .	68
16	Conversion of DD-11A Module for DMA Devices .	70
17	Priority Jumper Plug for RX02 . . . . .	73
18	Paper-tape Format . . . . .	85

LIST OF TABLES

<u>TABLE</u>		<u>PAGE</u>
I	Module Identifications . . . . .	21
II	TSLAP Software Routines . . . . .	35
III	TSLIB Software Routines . . . . .	36
IV	Major Operating System Programs . . . . .	38
V	Operating System Subroutines . . . . .	39
VI	Software Diagnostic Programs . . . . .	41
VII	Modal Analysis Package Programs . . . . .	42
VIII	BB11 Power Pin Assignments . . . . .	54
IX	UNIBUS Pin Assignments . . . . .	55

## ABSTRACT

This paper documents the procedures for upgrading a General Radio Time-Series Analysis 1923/30 System. The upgrading procedures included installation of a Heathkit H-19 CRT and interface of a DEC RX02 Disk Drive to the PDP-11/15 system computer. The RX02 Disk Drive interface required the installation of a KF11-A Multiple Bus Priority Module, KW11-L Line Time Clock Module, M8256 Controller Module, M9312 Bootstrap Module, software operating system, and the modification of the DD11-A Backplane Module.

Various hardware disk drive configurations and software operating systems were tested.

UPGRADE, VERIFICATION, AND DOCUMENTATION  
OF GENERAL RADIO 1923 TIME SERIES SYSTEM

I. INTRODUCTION

BACKGROUND

Analyzing electrical signals is a fundamental problem in the engineering field. Basic phenomena in any system can usually be converted into electrical signals. These electrical signals lend themselves to time-series analysis techniques (Ref 15:3).

Some examples of the use of time-series analysis include: vibration analysis in automobiles; determination of flutter characteristics in aircraft; analysis of electrocardiographs (EKG) and electroencephalograms (EEG) in biomedicine research; and echo ranging in geophysical exploration (Ref 15:3).

The term "time-series" means a succession of data values resulting from a physical process. Successive data values are related to previous data values in Time-Series Analysis. Basic Time-Series Analysis procedures include: correlation analysis, spectral analysis, filtering, ensemble averaging of waveforms, and measurement of statistical distributions (Ref 15:4).

The General Radio 1923/30 Time-Series System is a Digital Equipment Corporation (DEC) PDP-11/15 computer-based

digital processing system for broadband, high resolution analysis of analog input, and for general analysis, synthesis, and array manipulations of time series data (Ref 24:1-1). The system employs the fast fourier transform algorithm. This algorithm enables the system to perform simultaneous two-channel time-series analysis of data with bandwidths from zero to fifty kilocycles (Ref 24:1-1). Panel controls provide pushbutton selection of direct fourier transforms, signal power spectrums, histograms, and similar related analysis functions (Ref 24:1-1). Optional keyboard controls allow the operator to access individual steps of pre-programmed panel functions.

#### PROBLEM

The 1923/30 Time-Series System operates with a High-speed Paper Tape Reader. All of the problems generally associated with paper tape based systems are applicable to this system. The operator must overcome problems associated with handling and feeding the tape into the High-speed Paper Tape Reader. Additionally, paper tapes must be read into the processor memory separately. This separate loading procedure and the actual tape run-time greatly increase system set-up time. A DEC RX02 dual eight inch disk drive unit will be interfaced to the system computer in an effort to upgrade the equipment. A disk based system will improve system reliability, increase flexibility, and reduce the operational steps necessary for analysis of functional data.

The purpose of this thesis effort will be to:

1. Upgrade ASR-33 Teletypewriter (TTY) to a Heathkit H-19 Video Terminal (CRT).
2. Interface DEC RX02 Disk Drive Unit with PDP-11/15 computer in the 1923/30 Time-Series System.
3. Verify operation of the new disk based system.
4. Transfer existing paper tape based software onto eight inch floppy disks.

#### SCOPE

The thesis effort will proceed from a practical viewpoint. Existing hardware and/or software support within the Electrical Engineering Department will be used whenever possible. The proposed objectives, previously mentioned, will be covered with sufficient detail to ensure that the Time-Series System is properly upgraded, verified and documented. The DEC RT.11 software operating system and DEC diagnostic monitor files will be used for bootstrapping the RX02 Disk Drive Unit. The research effort will not include a rewrite of the software information on existing paper tapes. Hardware/software problem areas will be documented and recommended for future system improvements.

#### SUMMARY OF CURRENT KNOWLEDGE

First Lieutenant (1LT) Robert Sudduth conducted a thorough check of the 1923/30 Time-Series System during the

month of March 1980. The system had been in storage for about two years. Initially, 1LT Sudduth was unable to access or load portions of memory and unable to enter data via the ASR-33 TTY. Likewise, the system experienced intermittent power problems (Ref 20:1). The original PDP-11/15 was turned in for repairs and all defective sections of core memory were repaired on the original PDP-11/15 processor memory unit (Ref 20:4). Sudduth solved the problem of entering data via the teletypewriter by moving the interconnection of a KL-11 interface board in the processor from the five through seven priority slots to the one through four priority slots (Ref 20:4). The intermittent power problems were corrected by cleaning the connector contacts to the system power supply (Ref 20:6). The 1923/30 Time-Series System was declared fully operational when 1LT Sudduth concluded his research in 1980 (Ref 21:8). Although he got the system working, he was unable to replace the High-speed Paper Tape Reader with a disk unit (Ref 20:8). All other knowledge of the system has been obtained by a thorough review of the system operating/maintenance manuals and consultation with computer technicians familiar with the twelve year old DEC computer/Time-Series Analysis equipment.

#### STANDARDS

The following criteria will be used to verify that all objectives have been successfully completed:

1. The Heathkit H-19 CRT will successfully

perform I/O operations with disk based operating system.

2. The RX02 Disk Drive Unit will successfully boot-up on a floppy disk operating system.

3. All existing paper tapes will be transferred to floppy disks.

#### APPROACH

The following procedure was used in solving this problem. The entire 1923/30 Time-Series System was activated and checked for proper operation after a thorough study of the system operating manuals. All operating system paper tapes were checked for proper loading and operation.

The DEC RX02 Disk Drive Unit was connected to and powered up on an operational LSI-11 computer system to ensure proper operation and verification of boot-up procedures for the unit. The RX02 disk controller module and disk hardware bootstrap module were installed on the Time-Series System UNIBUS located in the PDP-11/15 computer. After installation of these modules, the RX02 disk unit was connected to the disk controller module. Power was applied to the system in order to check proper connections. The disk unit required an operating system to interface with the PDP-11/15 computer processor. A department RT.11 operating system disk was used. The disk for this system was copied from another RT.11 disk onto an eight inch standard floppy disk. Operating system files not required for the Time-Series System were eliminated by writing over memory locations. Additionally, a DEC XXDP.+

diagnostics floppy disk was used for boot-up procedures.

The system ASR-33 TTY was replaced with a more reliable video terminal (Heathkit H-19 CRT). Additionally, the department LSI-11 computer system was used to determine the capability and usefulness of the RT.11 operating system utility programs for transferring data to and from different storage medias.

## II. OVERVIEW OF 1923/30 TIME-SERIES ANALYSIS SYSTEM

### GENERAL SYSTEM DESCRIPTION

The 1923/30 Time-Series Analysis System is a computer-based digital processing system for broadband, high resolution analysis of analog input signals, and for general signal analysis of time series data. The system is capable of single or simultaneous two-channel analysis of data with bandwidths from d-c to 50KHZ. Spectral resolution is variable and ranges from sixty-four to four thousand ninety-six lines of constant filter bandwidth. Signal analysis is based primarily on the Fast Fourier Transform (FFT) algorithm. Operator controlled scaling of the FFT algorithm allows for optimum dynamic range calculations for a variety of signals (Ref 24:1-1).

The system operates in one of three modes: panel control; keyboard control; or learned program control. Panel control is achieved by loading the appropriate software panel control routine into the system PDP-11 computer core memory. Control is provided by the appropriate selection of pushbuttons on the Time-Series System front console. Commonly used Time-Series Analysis functions are available on the front console (Ref 24:1-1).

A separate software keyboard routine, loaded into computer core memory, provides the operator with keyboard control. The keyboard operating program allows the operator to control system operations by means of a high-level Time-Series Programming Language (TSL). The keyboard program is

accessed via the system teletype terminal or video terminal (CRT). The program includes the pre-programmed panel functions of the panel control program and provides more advanced array processing functions for the operator (Ref 24:1-3).

Learned program control is a specialized keyboard control mode. In the learned program control mode, relatively short programs are stored in computer core memory for execution at a later time (Ref 24:1-3).

#### PHYSICAL DESCRIPTION OF SYSTEM COMPONENTS

The 1923/30 Time-Series Analysis System consists of:

1. Digital Electronics Equipment (DEC) PDP-11/15 computer
2. Display Unit
3. Control Unit
4. Analog-to Digital Converter Unit (ADC)
5. System Power Supply
6. Extended Arithmetic Element (EAE)
7. ASR-33 Teletypewriter (TTY)
8. Heathkit H-19A video terminal CRT (additional modification)
9. X-Y Recorder
10. High-speed Paper Tape Reader
11. DEC RX02 Floppy Disk Unit (additional modification)
12. RT.11SJ Software Operating System (additional modification)
13. 1923/30 System Software Package

### DEC PDP-11/15 COMPUTER

The DEC PDP-11/15 is a 16 bit general purpose computer with 32K of core memory. The basic PDP-11/15 computer consists of a mounting box, tilt and lock chasis slides, H720 power supply, fifteen feet of power cord with ground wire, cooling fans, filter and programmer's console with turn-key option. The unit is ten and a half inches high, nineteen inches wide and twenty-three inches deep. The PDP-11/15 weighs approximately ninety pounds and operates on 120/220 VAC, 50/60 hertz. The computer is mounted between the DEC RX02 Disk Drive Unit and the Display Unit in the system rack (see Figure 1).

The system memory is provided by the DATARAM DR-103 Unit. The DATARAM DR-103 is a coincident-current, random access, ferrite core memory system. The DR-103 Unit has a 32K word capacity with 20 bits/word on a single printed circuit board assembly. The DR-103 assembly consists of drive electronics, stack, data register, and timing/control logic (Ref 1:1). The DATARAM DR-103 is mounted between the ADC Unit and the Power Supply Unit in the system rack (see Figure 1).

The PDP-11/15 is composed of a number of system units which are connected to and communicate with the central processor and other devices via a high-speed, fifty-six line bus known as the UNIBUS (Ref 8:128). The UNIBUS consists of three pre-wired BB-11 blank mounting panels and additional DD-11A peripheral mounting panels which are installed in the PDP-

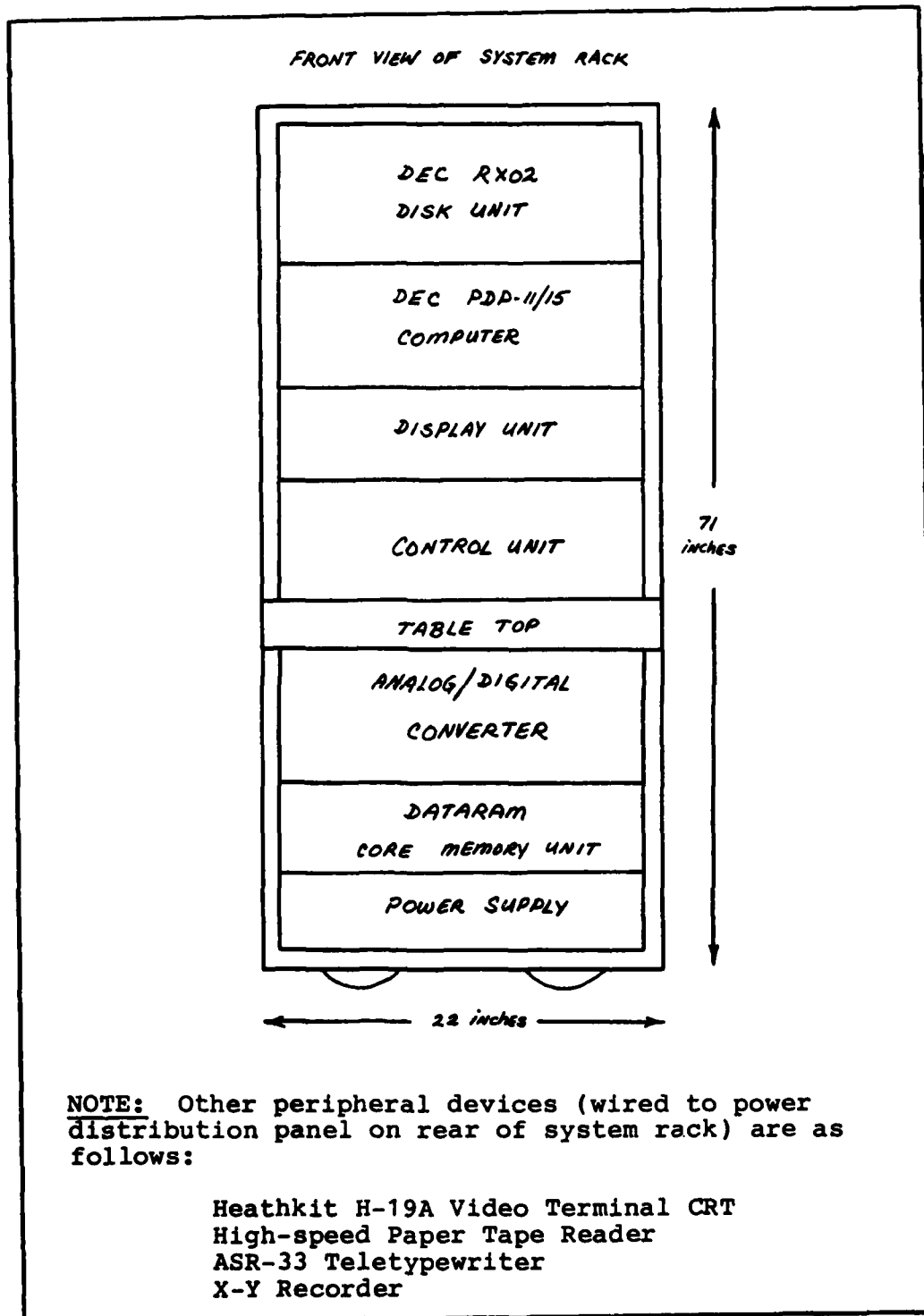

Figure 1. 1923/30 System Rack Configuration

11/15 mounting box. The DD-11A panels are interconnected to the system via M920 UNIBUS connector cards. The entire set of BB-11 and DD-11A panels comprise the UNIBUS structure. The processor and all external devices are connected to this UNIBUS via unit interface modules (see Figure 2). A typical BB-11/DD-11A module layout (Ref 9:238-241) is illustrated in Figure 3.

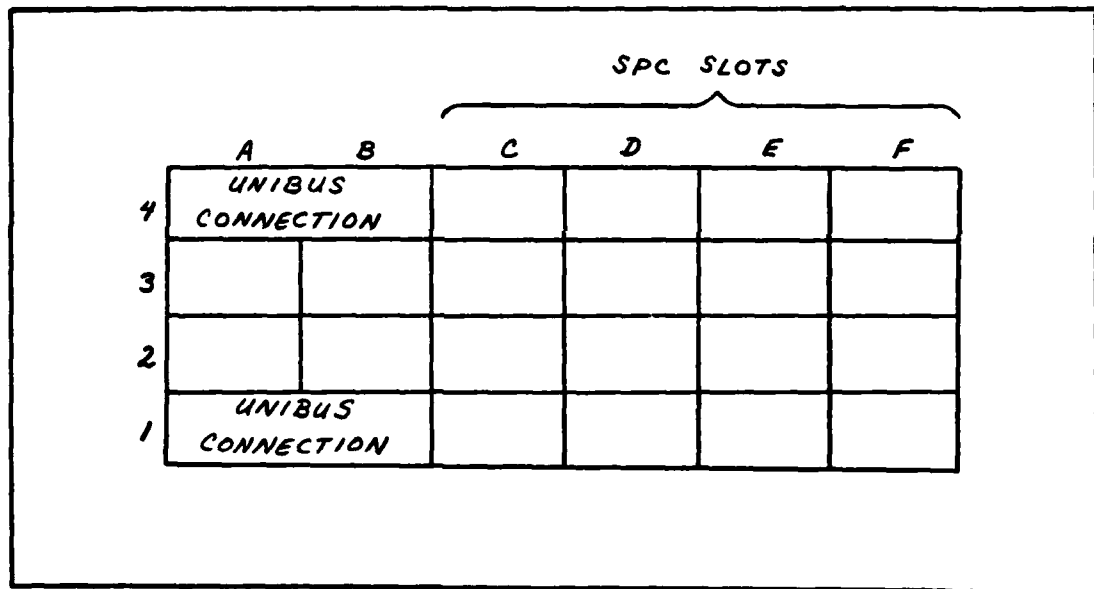

Figure 3. BB-11/DD-11A Module Layout

All system components are included in the UNIBUS structure via interface modules connected to selected slots in columns A through F. Power is always connected to the A3 slot with the A2 slot reserved for cable wire overhang. An M930 Bus

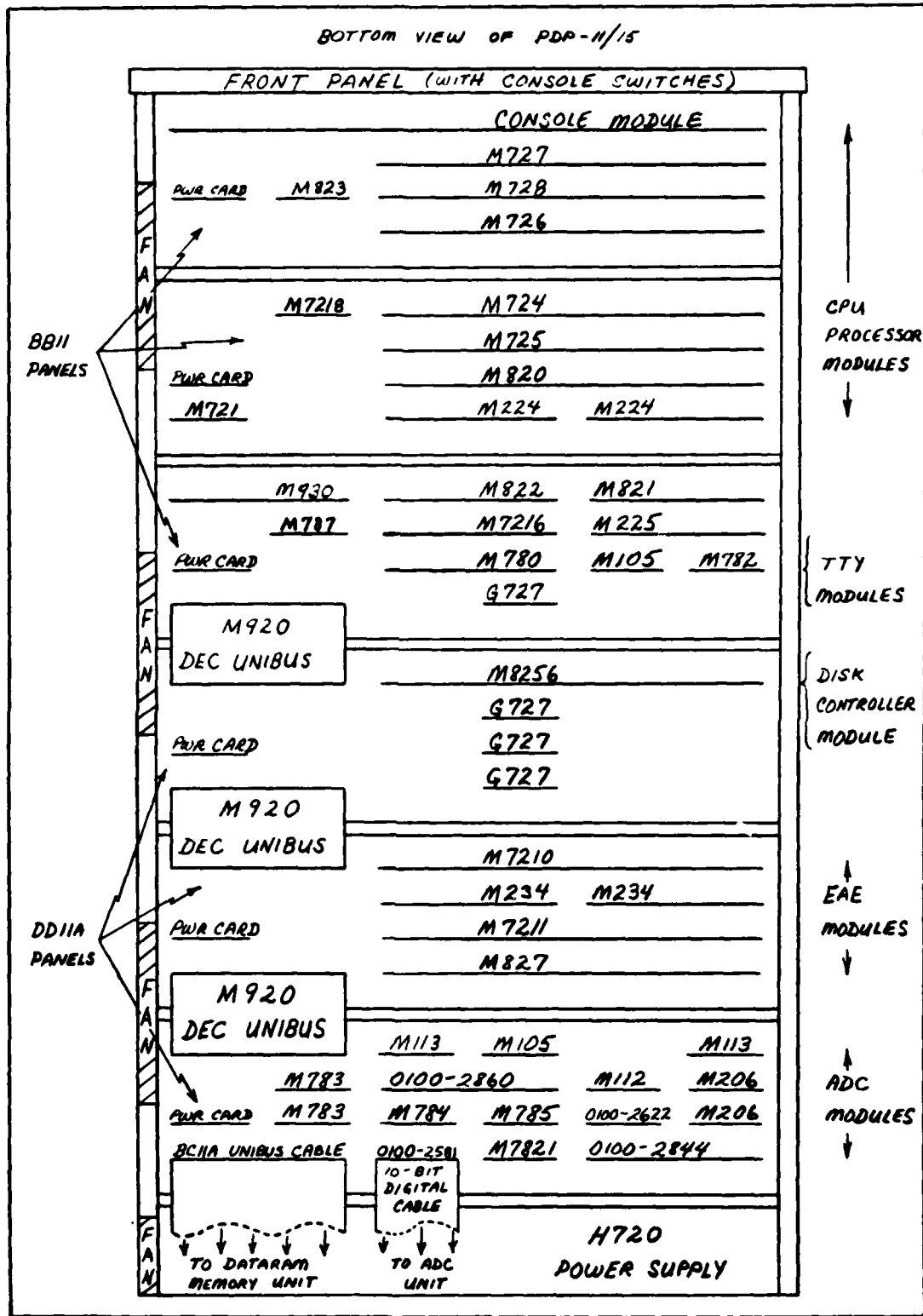

Figure 2. PDP-11/15 BOX CONFIGURATION

Terminator card must be installed in the last slot of the last DD-11A panel. In this system, the last Bus Terminator card is installed in the Control Unit. The PDP-11/15 UNIBUS structure is extended to the DATARAM core memory and system Control Unit. The UNIBUS is terminated in the system Control Unit. A simplified block diagram for the UNIBUS structure of this system (Ref 9:175) is as follows:

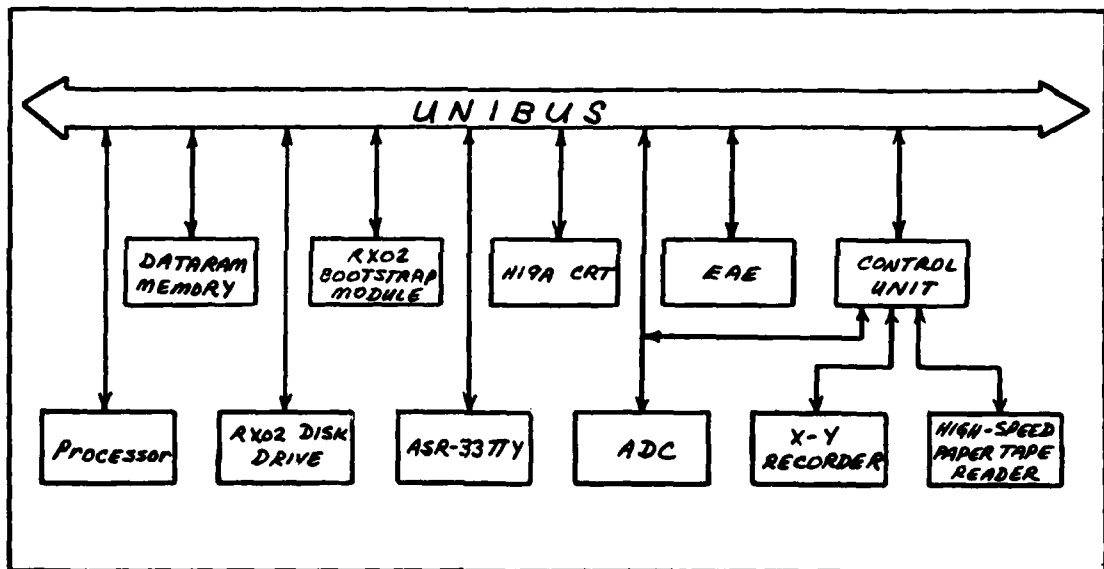

Figure 4. Simplified UNIBUS Block Diagram

#### DISPLAY UNIT

The Display Unit contains the system storage monitor 603 (general-purpose X-Y display monitor) and mounting panel for display related controls. The Display Unit is mounted between the PDP-11/15 computer and the Control Unit in

the system rack (see Figure 1). The X-Y Display monitor is a six and a half inch flat faceplate, electronic deflection CRT display with stored resolution of 80 line pairs vertically and 100 line pairs horizontally. Storage time is one hour at full stored brightness and erase time is about 250 milliseconds. The panel controls and the CRT are interfaced to the Time-Series System via cable connections to read-in and digital-to-analog modules in the Control Unit (Ref 24:1-12). Connectors, on the rear of the instrument, provide for application of input signals to the X and Y deflection amplifiers and to the Z-axis amplifiers which control beam intensity. The Display Unit operates on 120/220 VAC and includes a pre-wired power transformer which permits one of six regulatory ranges (Ref 21:1-3 and 1-4).

#### CONTROL UNIT

The Control Unit mounts the operator control panel. The operator control panel consists of display, output, averaging, system functions, display indicators, input modifiers, acquisition mode, sequence, execution, input A, input B, and input trigger control pushbuttons and/or switches. The Control Unit contains a secondary system bus. The secondary system bus is interfaced to the PDP-11/15 UNIBUS via a BC11A 120-conductor flexprint interface cable. The bus contains circuit cards for the control panel, keyboard Display Unit, programmable timing generator, optional filters, the X-Y

Recorder, and the High-speed Paper Tape Reader. The Control Unit is installed between the Display Unit and Analog-to-Digital converter in the system rack (see Figure 1). The unit operates on 120/220 VAC (Ref 24:1-12).

#### ANALOG-TO-DIGITAL CONVERTER UNIT

The Analog-to-Digital Converter Unit (ADC) contains two parallel analog-to-digital converters mounted in a single container between the Control Unit and the DATARAM core memory unit in the system rack (see Figure 1). Sample clock signals from the timing generator in the Control Unit and conditioned input signals from channel A and channel B in the Control Unit are input to the ADC via an interface cable. Ten bit digital outputs are cabled to the UNIBUS in the PDP-11/15 mounting box. All module cards containing control and interface logic for ADC operations are mounted on the UNIBUS structure in the PDP-11/15 computer (see Figure 2). The ADC operates on 120/220 VAC (Ref 24:1-14).

#### SYSTEM POWER SUPPLY

The System Power Supply Unit is mounted in the lowest available location in the system rack (see Figure 1). Voltages of +5VAC, -15VAC, and +15VAC are wired directly to the DC power distribution panel in the system rack (see Figure 1). Likewise, the same voltages are wired to standard three-prong power inlets along the system rack.

### EXTENDED ARITHMETIC ELEMENT

The Extended Arithmetic Element (EAE) consists of five modules mounted on the UNIBUS in the PDP-11/15 computer (see Figure 2). The five modules in the EAE are as follows:

<u>MODULE</u>	<u>QUANTITY</u>
M234 Register	2
M827 Clock and Status	1
M7210 Data Control	1
M7211 Register Control	1

The EAE UNIBUS addresses are hardwired to addresses 777300 through 777316. The EAE has no interrupt system and no interrupt vector address or priorities. The EAE is self-contained in the five modules mentioned above. Power for the EAE is provided by the PDP-11/15 UNIBUS structure (Ref 7:1-1).

### ASR-TELETYPEWRITER

The ASR-33 Teletype (TTY) is used as an input/output device for the PDP-11/15 computer system. The TTY consists of a printer, keyboard, paper tape reader, and paper tape punch. The TTY is interfaced directly to the PDP-11/15 UNIBUS structure via three KL11 Teletype Control modules. The three KL11 Teletype Control modules are as follows:

<u>MODULE</u>	<u>QUANTITY</u>
M105 Address Selector	1
M780 Receiver/Transmitter Timing	1
M782 Interrupt Control	1

The KL11 modules are inserted on the UNIBUS in one entire row behind the processor modules. The ASR-33 TTY is interfaced to the PDP-11/15 computer by an interconnect cable installed from the ASR-33 TTY to the M780 module. The ASR-33 TTY and the KL11 Control modules are set to operate on 110 baud rate. The ASR-33 TTY operates on 110/220 VAC from the system rack power distribution panel. The KL11 TTY Control modules are powered by the UNIBUS structure (Ref 24:1-12 and Ref 11:2-6). Either the ASR-33 TTY or the Heathkit H-19A Video Terminal CRT can be interfaced to the PDP-11/15 computer for input/output operations.

#### HEATHKIT H-19A VIDEO TERMINAL CRT

The Heathkit H-19A Video Terminal (CRT) is a 25 line video terminal connected to the PDP-11/15 computer by an RS-232C serial interface. The CRT consists of a twelve inch diagonal high-quality, cathode-ray tube, standard-size electronic keyboard (using standard typewriter format), logic circuit boards, and a molded cabinet. A current loop interface box is installed between the CRT terminal and the PDP-11/15 computer. The interface box provides the proper current and input/output serial interconnections for the CRT. The interface cable from the current loop box to the PDP-11/15 UNIBUS is connected to the KL11 M780 TTY Control module located on the UNIBUS structure. Either the ASR-33 TTY or the Heathkit H-19A CRT is connected to the KL11 M780 TTY

module for input/output operations. Both devices cannot be operated simultaneously in the current hardware configuration. The Heathkit H-19A CRT operates on 110/220 VAC (Ref 16:4).

#### X-Y RECORDER

The X-Y Recorder is a model 7034A Hewlett-Packard X-Y plotter. The unit consists of the mainframe table-type recorder, with front panel pushbutton controls, and includes two plug-in input modules. The two input modules are:

Model 17171A DC Preamplifier  
Model 17173A Null Detector

Slow varying DC signals are connected to the mainframe input terminals via banana plugs or open wires. The X-Y Recorder is connected to the Time-Series System as a peripheral device. The unit is powered by 110/220 VAC (Ref 17:1-1).

#### HIGH-SPEED PAPER TAPE READER

The High-speed Paper Tape Reader is a model 2540 series perforated tape reader. The unit consists of a readhead assembly (which includes an exciter lamp, collimating lens, and readhead), drive motor, electronics unit printed circuit board, power supply, capstans, rollers, and brake. The paper tape reader is a unidirectional, 300 character per second photoreader. The unit uses paper, paper-mylar, aluminized mylar, or solid mylar tape with standard perforations. The paper tape reader is interfaced to the PDP-

11/15 computer via interconnection cables, and is powered by 110 VAC, 60HZ (Ref 18:1-1 to 5-2).

#### DEC RX02 FLOPPY DISK UNIT

The Digital Equipment Corporation (DEC) RX02 Floppy Disk Unit is a low cost, random access mass storage memory device. The disk unit consists of two flexible disk drives, a single read/write electronics module (M7745), a microprogrammed controller module (M7744), power supply, PDP-11 Interface module (M8256), BC05L-15 standard interface cable, and a rack-mountable ten and a half inch self-cooled chassis. The media used with the RX02 unit is a flexible (floppy) eight inch disk. A bootstrap terminator module (M9312) is installed on the PDP-11/15 UNIBUS to provide a hardware loading and start-up sequence for the disk operating system. The disk unit is mounted directly above the PDP-11/15 computer in the system rack (see Figure 1). All disk components are mounted in the RX02 chassis, with the exception of the M8256 Interface module. The M8256 module is mounted directly behind the PDP-11/15 processor modules on the UNIBUS (see Figure 2). The RX02 unit is interfaced to the PDP-11/15 via the BC05L-15 interface cable. The cable is connected from the M8256 module to the RX02 unit. The RX02 unit operates on 110/220 VAC, double density format (Ref 13:1-1 and 2-3).

## FUNCTIONAL DESCRIPTION OF SYSTEM COMPONENTS

### DEC PDP-11/15 COMPUTER

The PDP-11/15 computer consists of a KC-11 processor, a KY-11C Controller Console, a DATARAM DR-103 core memory, a UNIBUS, and an H720 Power Supply (Ref 12:2-1).

The KC-11 processor is composed of several modules (see Figure 2) which decode instructions, modify data, make decisions, and control allocation of the UNIBUS among external devices by means of eight hardware registers. These registers are used as arithmetic accumulators, index, autoincrement and autodecrement, stack pointer, and counter registers (Ref 12:2-2). A complete listing and description of all modules in the PDP-11/15 computer is outlined in Table I.

The KY-11C Controller Console is a front panel console on the PDP-11/15 which provides the user with a direct system interface by means of manually operated console switches on the front console display. The console switches allow the operator to start, stop, load, modify, continue, and/or step through a user program one instruction at a time. The front console also indicates the current machine state of the computer (i.e., run, fetch, bus, execute, source, destination, address). Likewise, the console displays address load locations and deposited data at selected addresses. Console switch operating instructions are outlined in the PDP-11/15 system manual (Ref 12:2-2 and 2-3).

TABLE I. MODULE IDENTIFICATIONS

<u>MODULE</u>	<u>DESCRIPTION</u>	<u>FUNCTION</u>
G727	Grant Continuity Module	Provides jumpers to maintain UNIBUS continuity
M105	Address Selector Module	Provides gating signals for device registers
M112	NOR Gates Module	Nor logic for A/D interface
M113	NAND Gates Module	NAND logic for A/D interface
M206	D-Type FF Module	A/D interface logic
M224	Data Paths 1/2 Module	Processor logic
M225	Register Module	Processor logic
M234	Register Module	Contains three data registers, main adder and data paths for EAE
M721	Bus Interface Card	Provides drivers/receivers for bus data lines
M724	Bus and Console Control Module	Processor logic
M725	Bus Interface and IR Module	Processor logic
M726	IR Decode Module	Processor logic
M727	State Control Module	Processor logic
M728	Timing and States Module	Processor logic
M780	Receiver/Transmitter Timing Module	TTY/CRT logic
M782	Interrupt Control Module	TTY/CRT logic
M783	Transmitter Module	Sends Bus signals and
M784	Receiver Module	Receives Bus signals and provides buffered Bus signal output
M785	Transceiver Module	Used for bi-directional interfacing to UNIBUS

M787	Line Time Clock Priority Module	Accurately clocks 60HZ cycle
M820	Data Path Control Module	Processor logic
M821	Register Control Module	Processor logic
M822	Flag Control Module	Processor logic
M823	Codes Data Module	Processor logic
M827	Clock and Status Module	Contains timing, address and control logic for communication between EAE and UNIBUS
M920	UNIBUS Jumper Module	Connects UNIBUS from one system to the next
M930	Bus Terminator Module	Terminates all signal lines on UNIBUS
M7210	Data Control Module	Contains EAE Data receivers/drivers/step-counter/status reg/logic
M7211	Register Control Module	Controls EAE data paths and registers that hold operand/operations results
M7216	Priority and Control Module	Processor logic
M7218	Multiple Request Option Module	Handles priority four to seven interrupts
M7821	Interface Control Module	A/D Interface logic
M8256	RX02 Interface Module	Controller for RX02 disk
M9312	Bootstrap Terminator Module	Provides hardware bootstrap for RX02 disk
0100-2581	A/D Interface Cable	Transfers 10-bit digital signals between UNIBUS and ADC unit
0100-2622	Word Count Module	A/D Interface logic
0100-2844	DMA Control Module	Controls input from ADC to core memory
0100-	Address Counter Module	A/D Interface logic

The DATARAM DR-103 core memory is a random access, magnetic core read/write memory which transfers data to and from the processor and other devices by means of the system UNIBUS. The memory has no priority structure. Consequently, any master device can perform direct memory data transfers without processor intervention (Ref 1:1).

The UNIBUS is a single, high-speed bus which provides communication between system components by means of a fifty-six line hardware bus configuration. Two devices on the UNIBUS communicate via a master-slave relationship. The device with control of the bus is called the "master". The other device controlled by the "master" is referred to as the "slave". All devices capable of becoming a master of the bus are assigned a priority. The system priority structure determines which device gains control of the UNIBUS. When two devices have the same priority, the device electrically closest to the processor is granted bus control. Direct memory or data transfers between two peripheral devices can be accomplished without involving the processor (Ref 9:175-176).

The H720 Power Supply is a mechanical device which provides power for the PDP-11/15 computer by means of a power bus. Additionally, the power supply provides DC LO and AC LO logic signals which control DC and AC voltages in the system (Ref 12:2-5).

#### DISPLAY UNIT

The 603 general purpose X-Y display monitor

display unit is a general purpose X-Y display monitor which provides stored displays of analog data from Time-Series calculations by means of a 603 Storage Monitor with associated display related controls. Deflection amplifiers in the display monitor process input signals and provide push-pull outputs capable of driving the vertical and horizontal deflection plates in the monitor. An internal CRT circuit produces a high voltage potential and provides the control circuits needed for CRT operation. A power supply circuit in the monitor provides the necessary low-voltage power for the 603 monitor and stable regulation of output voltages. The 603 monitor manual describes in detail the functions of the panel controls (Ref 21:1-2 to 1-6 and 2-1 to 2-3).

#### CONTROL UNIT

The Control Unit is an electrical device which provides control and interfacing for keyboard and control/display panels by means of read-in, lamp driver and logic control circuits. The Control Unit scans all controls while in an idle mode, interprets the settings, sets up internal control parameters/programmable hardware and displays appropriate control panel lights. Analog inputs on the rear external connectors of the Control Unit are attenuated to appropriate signal levels via programmable attenuators on the secondary Control Unit bus. The Control Unit also provides internally generated 1KHZ square wave test signals on both channels or external test signals which can be left

permanently connected to the rear of the Control Unit. Analog input/output connections on the rear of the Control Unit are displayed in Figure 5 (Ref 24:2-3).

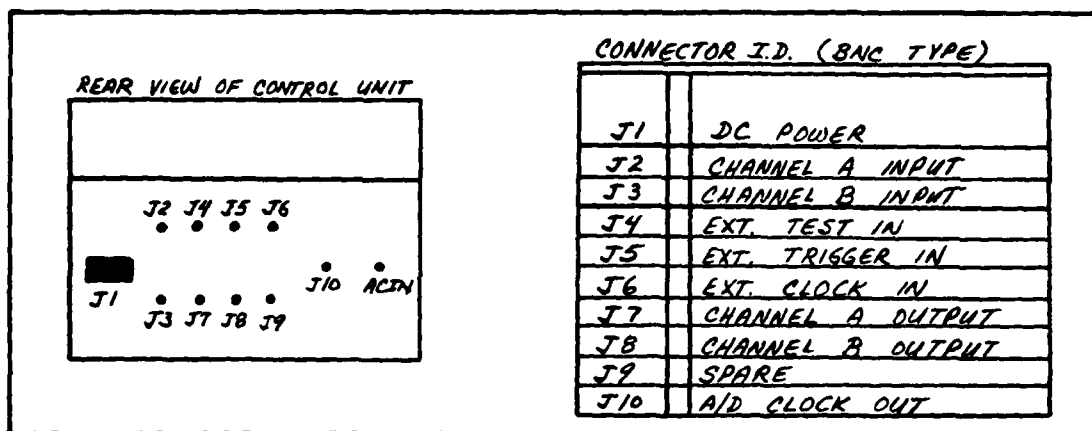

Figure 5. Analog Input/Output Connectors on Control Unit

Trigger and sweep generators in the Control Unit provide horizontal inputs to the CRT for analog display. The trigger generator also controls the Analog-to-Digital Converter (ADC) sampling clock. The sweep generator is driven by a timing generator oscillator. The timing generator in the Control Unit produces an analog display sweep clock and the ADC sampling frequency clock (Ref 24:1-14 to 1-16).

#### ANALOG-TO-DIGITAL CONVERTER UNIT

The ADC is an electrical device which simultaneously samples channels A and B from the system filters, performs parallel conversions to ten bit resolution, and sends the digital words to the direct memory access (DMA) input interface on the PDP-11/15 UNIBUS by means of register

transfer operations. DMA input transfers do not interfere with parallel processor operations. As a result, once processing is started input transfers to core memory occur without delay. For bandwidths greater than 50KHZ, the Analog-to-Digital Converters can process 100K words per second per channel (Ref 24:1-17).

#### SYSTEM POWER SUPPLY

The system power supply is an electrical device which provides +5VDC, -15VDC, and +15VDC for the ADC and Control Unit by means of a DC power distribution box mounted on the system rack. Additionally, the system power supply unit provides +5VDC to the system power distribution panel. This +5VDC power is utilized by the system fans (Ref 24:1-17).

#### EXTENDED ARITHMETIC ELEMENT

The KE-11A Extended Arithmetic Element (EAE) is a device which performs multiplication, division, multiple position shifts and normalization on numerical data by means of clock and status (M827), register control (M7211), register low byte (M234), register high byte (M234) and data control (M7210) modules. The EAE performs arithmetic operations many times faster than software routines (Ref 8:143).

The Clock and Status (M827) module enables the EAE to communicate with the UNIBUS by means of basic timing signals from a transfer clock, control circuits which start and stop the clock, and address recognition logic (Ref 7:5-2).

The Register Control (M7211) module controls the data paths and registers that hold the operands/operand results (Ref 7:5-6). The Register High/Low Byte (M234) modules contain three data registers, the main adder, and data paths which connect these registers (Ref 7:5-10 and 5-11). The Data Control (M7210) module contains the bus data receivers and drivers, step counter, five bits of the status register and associated logic which enables this module to control data transfers (Ref 7:5-12).

#### ASR-33 TELETYPEWRITER

The ASR-33 Teletypewriter (TTY) is a mechanical device which performs input/output operations for the PDP-11/15 computer by means of a printer, keyboard, paper tape reader, and paper tape punch. The printer provides the user with a hard copy of input/output. The keyboard of the ASR-33 TTY enables the user to input teletype commands and/or programs. The paper tape reader reads pre-punched eight channel perforated paper tape. The paper tape punch perforates eight channel paper tape (Ref 9:5-6).

The ASR-33 TTY is interfaced to the PDP-11/15 UNIBUS via the address selector (M105), interrupt control (M782), and receiver/transmitter timing (M780) modules. These modules are referred to as the KL11 Teletype Control. The KL11 Teletype Control assembles or disassembles serial information for parallel transfer on the UNIBUS. The address selector module decodes the incoming address from the bus.

The interrupt control module generates an interrupt. The receiver/transmitter module performs conversion and formatting functions (Ref 12:2-6).

#### HEATHKIT H-19A VIDEO TERMINAL CRT

The Heathkit H-19A Video Terminal CRT is a device which performs input/output operations for the PDP-11/15 computer by means of a high-quality keyboard, video display CRT, and logic circuitry. The keyboard enables the user to input keyboard commands/user programs. The CRT provides a video display of the system input/output. The logic circuitry consists of power supply, video, video driver, and terminal logic circuit boards. The power supply circuit board rectifies 115/230V input to provide 65VDC, 8.5VDC, -16VDC and +16VDC input to the unit (Ref 16:32). The video and video driver circuit boards provide logic circuitry for the CRT (Ref 16:33-36). The terminal logic circuit board provides logic circuitry for the H-19A processor/CPU, keyboard logic, master clock and system logic, communications, CRT and memory control, display memory, character generator and video control logic (Ref 16:36-44).

#### X-Y RECORDER

The X-Y Recorder is a device which provides graphic traces showing the relationship between two variable functions by means of input modules, servomechanisms, differential voltage comparators, high power DC motors, and a pen arm assembly. The input module 17171A is a DC

preamplifier which increases the input voltages for fixed and vernier range operations (Ref 17:4-1). The input module 17173A is a null detector which plots analog data in discrete point form (Ref 17:1-1). The X-Y Recorder consists of the servomechanisms. One servomechanism moves the pen carriage vertically while the other moves the entire carriage arm horizontally in response to input signals. The resulting motions provide a cartesian trace of the data (Ref 17:4-1). The differential voltage comparators provide a balancing action in the system when the input signals may be continually changing (Ref 17:4-1). The high power DC motors enable the recorder to be highly responsive to data input (Ref 17:4-1). The pen arm assembly houses the drawing pen and mechanical arm required for X-Y plots (Ref 17:4-1).

#### HIGH-SPEED PAPER TAPE READER

The High-speed Paper Tape Reader (model 2540) is a mechanical device which reads perforated tape and converts information on punched tape into DC signal levels compatible with circuit logic by means of a readhead assembly, driver motor, electronics unit printed circuit board, power supply, capstans, rollers, and brakes (Ref 18:1-1). The readhead assembly converts the punched tape information into DC signal levels. Holes in pre-punched tape pass over the readhead and cause light to strike a photovoltaic cell in the readhead. As a result, the cell produces a DC voltage. This signal level is transmitted to the computer (Ref 18:4-4). The drive motor

provides primary mechanical power for the tape drive system (Ref 18:4-1). The electronics unit provides regulated 24VDC for the readhead exciter lamp and controls tape motion/output data (Ref 18:4-3). The power supply unit provides all of the operating and drive voltages required by the reader and electronics unit (Ref 18:1-1). The capstans, rollers and brakes enable the paper tape to flow across the readhead assembly at the proper speed and alignment.

#### DEC RX02 FLOPPY DISK UNIT

The DEC RX02 Floppy Disk Unit is an electronic device which provides a mass storage software distribution medium by means of two flexible disk drives, a single read/write electronics module (M7745), a microprogrammed controller module (M7744), power supply and PDP-11 Interface module (M8256). The single read/write electronics (M7745) and microprogrammed controller (M7744) modules provide all the necessary control circuitry for the read and write operations on the disk. Additionally, the modules calculate and verify the cyclic redundancy check (CRC) at the end of the data field for errors (Ref 13:4-34). The PDP-11/15 Interface module (M8256) converts the RX02 input/output bus to a PDP-11 UNIBUS structure. The module also controls interrupts to the CPU initiated by the RX02, decodes UNIBUS addresses for register selection and initiates non-priority requests (NPR) to transfer data between the RX02 and the PDP-11/15 computer (Ref 13:1-7).

## SYSTEM SOFTWARE PROGRAMS

Several software packages exist for the 1923/30 Time-Series Analysis System. The DEC RT.11SJ Software Operating System is copied onto the system eight inch floppy disk medias in double density format. The RT.11SJ Operating System consists of: a monitor/executive program for system control and supervision; several device handler programs for each hardware supported input/output device; and a variety of utility programs for program and/or data creation and manipulation (Ref 6:1-10). The following TSL software packages exist on both eight inch floppy disks and paper tape:

1. TSL System Program for panel control
2. TSL System Program for keyboard control
3. TSL Analysis (TSLAP) and Library Utility (TSLIB) Programs
4. Core Memory Loading and Dumping Programs
5. Program Assembly Language (PAL-11)
6. Text Editor (ED-11)
7. On-Line Debugging Programs (ODT-11)
8. Linker Programs (LINK-11S)
9. Input/Output Executive Programs (IOX-11)
10. Floating-Point Math Package (FPMP-11)
11. Diagnostic Programs
12. X-Y Plotter Program
13. Modal Analysis Package (MAP)

The Time-Series Language (TSL) used in the system unit

is a high-level computer programming language derived from BASIC. TSL was designed specifically to be used with time-series analysis and signal processing applications. TSL provides: combinations of integer, floating point, real, and complex arithmetic; Fourier transform operations; block arithmetic functions for time-series signal analysis; Laplace analysis functions; on-line debugging and editing commands; and input/output instructions for various peripheral devices (Ref 27:1-1). The TSL package was designed specifically for operation with the PDP-11 computer. It supports all Time-Series System two-channel analysis ADC operations (Ref 27:1-6). TSL programs are written and/or executed by using the ASR-33 Teletype or Heathkit H-19A CRT keyboard. The Time-Series Language Programming Manual (see reference 27) explains basic TSL programming commands and procedures. The following analysis describes the major TSL software packages and their key subroutines.

#### TSL SYSTEM PROGRAM FOR PANEL CONTROL

The PANEL-C and/or PANEL-30 System Programs provide pushbutton selection of time-series analysis functions from the Control Unit and Display Unit front consoles. PANEL-30 is a second generation replacement program for the PANEL-C Program. It uses a revised software Fast Fourier (FFT) algorithm which provides a two-to-one improvement in Fourier processing speed for averaged auto-spectra. PANEL-30 also allows for greater range of absolute values and provides

better display calibration (Ref 26:1-5). The newer version Panel Control Program (PANEL-30) is copied on the disk medias for panel control utilization. The older version Panel Control Program (PANEL-C) is available only on paper tape and is intended for standby use only. A list of standard panel program commands/functions are outlined in the Time-Series Operating Manual (see reference 27), Table 1-1, page 1-5.

#### TSL SYSTEM PROGRAM FOR KEYBOARD CONTROL

Keyboard control, via the system TTY or CRT keyboard, is achieved by use of the TSL-30 Program. The TSL-30 Program allows the operator to use the pre-programmed panel functions and provides access to individual processing steps used in the final panel function results. In this manner, the operator can perform processing modifications to block arithmetic, differentiation, integration, complex functions, and direct convolution calculations. Additionally, the user can write subroutines using the TSL commands (Ref 24:1-3). A list of standard keyboard program commands/functions are outlined in the Time-Series Operating Manual (see reference 24), Table 1-2, page 1-9.

#### TSLAP AND TSLIB PROGRAMS

The TSL Analysis (TSLAP) Programs are pre-programmed routines used for analysis of one or two channels of analog input data. The TSLAP routines provide data acquisition, spectral processing, averaging of successive

results, final processing, and displays for the following time-series analysis functions (Ref 25:12-1):

1. Fourier Transform
2. Auto and Cross Power Spectrum
3. Transfer and Coherence Function
4. Auto and Cross Correlation
5. Amplitude Histogram
6. Time Domain Waveform Averaging

A list of TSLAP routines for the Time-Series System is outlined in Table II (Ref 25:12-3 to 12-5).

The TSL Library Utility (TSLIB) Programs are pre-programmed routines which enable the user to create library format routines, direct input/output of data blocks to/from paper tape, and manipulate data via miscellaneous routines which are not part of basic TSL (Ref 25:13-1). A list of TSLIB routines for the Time-Series System is outlined in Table III (Ref 25:13-2 to 13-3). The TSLAP and TSLIB routines are located in the TSL applications #1, #2, #3 and TSL Amplitude Histogram Files. Both the TSLAP and TSLIB routine operating instructions are outlined in the TSL Programming Manual. Quick reference start-up procedures and system error codes are outlined in the TSL Reference Handbook.

#### CORE MEMORY LOADING PROGRAMS

The Bootstrap Loader is a program which instructs the computer to load into core memory data which is punched on tape in bootstrap format. The Bootstrap Loader is manually

TABLE II. TSLAP SOFTWARE ROUTINES

<u>NAME OF ROUTINE</u>	<u>DESCRIPTION</u>
SETUP	A dialog routine that prints a list of required processing parameters and requests entry of specifying codes
PARAM	An echo routine that prints back the current setup parameter codes
SAMP	Routine continuously acquires and displays blocks of sampled input data
FFT	Forward Fourier Transform. Computes and displays the complex Fourier Coefficients of input waveform
APS	Auto Power Spectrum. Computes and displays the real power spectral coefficients
XPS	Cross Power Spectrum. Computes and displays the complex common power coefficients and phase differences between two channels
TRAN	Transfer Function. Computes and displays complex transfer function. Computes coherence function and retains channel auto-spectra and cross-spectrum
ACOR	Auto-Correlation. Computes and displays correlation function of one or both input waveforms in time relative to themselves
XCOR	Cross-Correlation. Computes and displays correlation function between input waveforms
HIST	Amplitude Histogram. Computes and displays amplitude distribution of input waveforms
WAVE	Waveform averaging. Computes and displays time-domain average of one or both channels
DISPLY	Routine draws a ten division by ten division grid on the CRT/X-Y Plotter, establishes a horizontal zero reference line, labels axes and scales, and then presents data on scale background. <u>The DISPLY routine is required by all TSLAP functions</u>

TABLE III. TSLAB SOFTWARE ROUTINES

<u>NAME OF ROUTINE</u>	<u>DESCRIPTION</u>
LIB	Lists, searches, and loads routines from library format tapes
BTAP	Converts tapes in PDP-11 load module format to a format loadable by TSL
BLKIN, BLKOUT BLKINS, BLKOUS	Routines to input and output TSL-defined data blocks
COPY	Routine to duplicate tapes
DATA	Routine to load a string of data into successive locations
DFLOAT	Routine to convert a data block in double precision format to floating point format
LIBC	Routine to convert ordinary TSL tapes to library format tapes
MEMAP	Routine to print memory map of currently defined blocks
PBIB	Similar to MEMAP. Prints single specified block and gives complete block description
PUNCH	Similar to SAVE routine of basic TSL. Routine prints routines in machine language
ROTATE	Performs end-around rotation of elements of a TSL block
SAVE2, SAVE3	Similar to SAVE routine of Basic TSL. Routine punches a format which can be loaded regardless of prior loading of subroutine name
TSLAVG	Machine language routine for high-speed addition of one block to another
TSLHST	Machine language routine to produce histogram

NOTE: Detailed operating instructions for each of the routines listed above are outlined in the TSL Programming Manual, pages 13-9 to 13-24.

loaded into the highest core memory location via the PDP-11/15 console switches (Ref 11:6-2).

The Absolute Binary Loader is a program which enables the user to load paper tapes, punched in absolute binary format, into any core memory location. The Absolute Binary Loader is pre-programmed on paper tape in bootstrap format. The Bootstrap Loader is used to load the Absolute Binary Loader which, in turn, is used to load paper tapes punched in absolute binary format (Ref 11:6-8).

#### CORE MEMORY DUMPING PROGRAMS

The paper tape software package includes two dump programs called DUMPTT and DUMPAB. DUMPTT dumps octal representations of core memory onto the system TTY/CRT, or high-speed paper tape punch. The DUMPAB program dumps absolute binary code from specified core locations onto the high-speed paper tape punch. Both programs exist on paper tape in bootstrap and absolute binary formats (Ref 11:6-12). Operating procedures for both dump programs are outlined in the PDP-11 Paper Tape Software Programming Handbook on page 6-13.

#### OPERATING SYSTEM PROGRAMS

The following table outlines programs which allow the user to assemble, edit, debug, link, and control program input/output (Ref 8:155-159):

TABLE IV. MAJOR OPERATING SYSTEM PROGRAMS

<u>NAME OF PROGRAM</u>	<u>PROGRAM FUNCTION</u>
Program Assembly Language (PAL-11)	Program enables user to write programs in meaningful symbols which are later assembled into Absolute Binary code
Text Editor (ED-11)	Program enables user to display source programs on TTY/CRT, make corrections, and punch final program on paper tape
On-line Debugging Programs (ODT-11)	Program aids in debugging assembled object programs
Linker (LINKER-11S)	Program produces a load module which is loaded for execution
Input/Output Executive (IOX-11)	Program frees user from details of dealing directly with input/output devices

Detailed operating instructions for all Operating System Programs are outlined in the PDP-11 Paper Tape Software Programming Handbook. A complete breakdown of programs within each major program category in Table IV is outlined in Table V (Operating System Subroutines).

FLOATING-POINT MATH PACKAGE (FPMP-11)

The FPMP-11 software programs provide the user with an easy means of performing arithmetic operations, transcendental functions, type conversions and ASCII

TABLE V. OPERATING SYSTEM SUBROUTINES

1. CORE MEMORY LOADING AND DUMPING PROGRAMS

ABSOLUTE LOADER (V006A)  
DUMPTT-TELETYPE OCTAL DUMP (V001A) - PB  
DUMPTT-TELETYPE OCTAL DUMP (V001A) - PO  
DUMPAB-ABSOLUTE BINARY DUMP(V001A) - PB  
DUMPAB-ABSOLUTE BINARY DUMP(V001A) - PO

2. PROGRAM ASSEMBLY LANGUAGE (PAL-11) PROGRAMS

PAL-11A (V007A) - ASSEMBLER  
PAL-11S (V003A)  
PAL-11S.OBJ (V003A) TAPE 1 OF 6  
PAL-11S.OBJ (V003A) TAPE 2 OF 6  
PAL-11S.OBJ (V003A) TAPE 3 OF 6  
PAL-11S.OBJ (V003A) TAPE 4 OF 6  
PAL-11S.OBJ (V003A) TAPE 5 OF 6  
PAL-11S.OBJ (V003A) TAPE 6 OF 6

3. TEXT EDITOR (ED-11) PROGRAM

ED-11 TEXT EDITOR (V005A)

4. ON-LINE DEBUGGING (ODT-11) PROGRAMS

ODT-11 ON-LINE DEBUGGER (V005A) - PB  
ODT-11 ON-LINE DEBUGGER (V005A) - PA  
ODT-11 ON-LINE DEBUGGER (V007A) - PB  
ODT-11 ON-LINE DEBUGGER (V007A) - PA

5. LINKER (LINK-11S) PROGRAMS

LINK-11S.LDA (V002A) TAPE 1 OF 1  
LINK-11S.OBJ (V002A) TAPE 1 OF 2  
LINK-11S.OBJ (V002A) TAPE 2 OF 2

6. INPUT/OUTPUT EXECUTIVE (IOX-11) PROGRAMS

IOX I/O EXECUTIVE (V006A) TAPE 1 OF 2  
IOX I/O EXECUTIVE (V006A) TAPE 2 OF 2

conversions. The FPMP-11 programs store very large and very small numbers by retaining only significant digits in computations. The floating-point notation makes calculations easy. The FPMP-11 package consists of a single precision program (Tape 1 of 2), a double precision program (Tape 1 of 2), and six source programs (Ref 2:1-1 and 1-2).

#### DIAGNOSTIC PROGRAMS

Table VI (Diagnostic Programs) lists all diagnostic programs for the Time-Series System. The diagnostic programs enable the user to check system operations, paper tape functions, and specified processor commands.

#### X-Y PLOTTER PROGRAM

The X-Y Plotter Program enables the system user to obtain hard copy X-Y plots of signal analysis operations. The X-Y Plotter Program is loaded into core memory as an additional subroutine following the basic system program loading procedures.

#### MODAL ANALYSIS PACKAGE (MAP)

The MAP uses a Fourier Transform as a source in order to develop a set of mode descriptors representing the corresponding Laplace Transform. The descriptors used to describe the Laplace Transform poles are frequency, attenuation, amplitude and phase. The MAP consists of five subroutines which are supplied as an integral part of the

TABLE VI. SOFTWARE DIAGNOSTIC PROGRAMS

1. Basic Address Test (UP)
2. Basic Address Test (DOWN)
3. Basic Memory Patterns Test
4. Communication Test Program (CTP)
5. Core Heating Test
6. EAE Random Exerciser
7. General Test Program
8. KL-11/DL-11A TTY Tests
9. Maintenance Loader
10. Memory Moving One's and Zero's Test
11. No Dual Address Test
12. One's and Zero's Test Tape
13. PDP-11 Paper Tape System Checkout Package:
  - Test B Tape 1 of 2
  - Test A Tape 2 of 2
  - TAPDUP.ASC(2) Tape 1 of 2
  - TAPDUP.ASC(1) Tape 2 of 2
14. Power Fail Diagnostic
15. Randat
16. Special Binary Count Pattern
17. Test Programs:
  - #1 Branch Test
  - #2 Con Branch Test
  - #3 Unary Test
  - #4 Unary and Binary Tests
  - #5 Rotate/Shift Tests
  - #6 Compare Test
  - #7 Compare Not Test
  - #8 Move Test
  - #9 BIS, BIC, and BIT Tests
  - #10 Add Test
  - #11 Subtract Test
  - #12 Jump Test
  - #13 JSR, RTS, and RTI Tests
  - #14 Trap Tests
  - #15 Family Instruction Exerciser
  - #17 4K System Exerciser
18. Up-down Address Test
19. Worst Case Noise Test
20. 1's Susceptability Test

basic TSL program. The five subroutines used in the MAP program (Ref 23:1-2) are outlined in Table VII (Modal Analysis Package Programs):

TABLE VII. MODAL ANALYSIS PACKAGE PROGRAMS

<u>NAME OF ROUTINE</u>	<u>DESCRIPTION</u>
Minimum Phase Routine (MP)	Routines converts squared magnitudes of an auto spectrum to a complex function of equivalent magnitudes
Mode Separator Routine (MS)	Routine operates on a complex Fourier Transform to derive a peak location function
Mode Detector Routine (MD)	Routine finds, evaluates and records peaks that fall within frequency, damping, and threshold specified limits
Mode Evaluator Routine (ME)	Routine produces the final Laplace Transform result in the form of the four pole descriptors
Mode Generator Routine (MG)	Routine regenerates a complex function of frequency. It is useful in comparisons with original source function

### III. UPGRADE PROCEDURES FOR 1923/30 SYSTEM

#### GENERAL APPROACH

The 1923/30 Time-Series Analysis System was upgraded by means of the following procedures:

1. Installation of Heathkit H-19A CRT Terminal, in place of ASR-33 TTY, to enhance I/O operations.
2. Reconfiguration of PDP-11/15 computer to include only CPU processor modules, small peripheral controller modules and core memory.
3. Interface of RX02 Disk Drive Unit to reconfigured PDP-11/15 computer structure.
4. Bootstrap of RX02 Disk Drive Unit to PDP-11/15 using existing floppy disk operating system.

#### INSTALLATION OF HEATHKIT H-19A CRT

The 1923/30 Time-Series Analysis System utilizes an ASR-33 TTY for I/O terminal operations. An H-19A Heathkit CRT terminal was interfaced to the system to enhance I/O operations. Hard-copy output for I/O operations can still be achieved by disconnecting the H-19A interface and installing/operating from the ASR-33 TTY via simple cable connections.

The Heathkit H-19A was interfaced to the PDP-11/15 system by means of an RS-232C interface unit. The RS-232C unit was installed between the H-19A CRT and the TTY Controller (M780) Module located in the processor. The TTY

interface cable from the M780 Controller Module was connected to the Current-loop side of the RS-232C interface unit. The 25-pin "D" connector on the RS-232C interface unit output was connected to the 25-pin "D" connector on the H-19 CRT. The RS-232C interface unit is constructed to convert current-loop output from the TTY Controller Module to RS-232C standard signal levels. The Data Terminal Equipment inputs/outputs for RS-232C standards (Ref 16:12) are as follows:

H-19 TERMINAL

RS-232C INTERFACE BOX

PIN CONNECTIONS

P GND	1	-----	1	Protective Ground
S OUT	2	-----	2	RS-232C Serial Output
S IN	3	-----	3	RS-232C Serial Input
RTS	4	-----	4	Request to Send Output
CTS	5	-----	5	Clear to Send Input
DSR	6	-----	6	Data Set Ready
S GND	7	-----	7	Signal Ground
DTR	20	-----	20	Data Terminal Ready Output

The RS-232C interface unit is not required when the ASR-33 TTY is installed. The ASR-33 and TTY Controller Module cables are constructed so direct interfacing is possible via cable connections from the TTY Controller Module to the ASR-33 TTY.

The Heathkit H-19A CRT Terminal has two internal switches (S401 and S402) which control various terminal operations (Ref 16:10). The S401 switch descriptions are as follows:

<u>SWITCH NUMBER</u>	<u>DESCRIPTION</u>
0-3	Baud Rate

4	Parity Enable
5	Odd/Even Parity
6	Normal/Stick Parity
7	Half/Full Duplex

The specific baud rate settings are as follows:

<u>SWITCH NUMBERS</u>				<u>BAUD</u>
<u>0</u>	<u>1</u>	<u>2</u>	<u>3</u>	<u>RATE</u>
0	0	0	0	N/A
1	0	0	0	110
0	1	0	0	150
1	1	0	0	300
0	0	1	0	600
1	0	1	0	1200
0	1	1	0	1800
1	1	1	0	2000
0	0	0	1	2400
1	0	0	1	3600
0	1	0	1	4800
1	1	0	1	7200
0	0	1	1	9600

The S402 switch descriptions are explained below:

<u>SWITCH</u>	<u>DESCRIPTION</u>
0	0=underscore cursor; 1=block cursor
1	0=key click; 1=no key click
2	0=discard past end of line; 1=wrap around
3	0=no auto LF or CR; 1=auto LF on CR
4	0=no auto CR on LF; 1=auto CR on LF
5	0=Heath mode; 1=ANSI mode
6	0=keypad normal; 1=keypad shifted
7	0=60 HZ refresh; 1=50 HZ refresh

The switch settings were set as follows:

<u>S401</u>	<u>SWITCH</u>	<u>S402</u>	<u>SWITCH</u>
<u>SWITCH</u>	<u>SETTING</u>	<u>SWITCH</u>	<u>SETTING</u>
0	0	0	1
1	0	1	0
2	1	2	0
3	0	3	0
4	0	4	0

5	0	5	0
6	1	6	0
7	0	7	1

The Heathkit H-19A CRT was set on 110 baud rate (S402 setting "1000") and 60 HZ refresh (S401 setting "0"). The 110 baud rate is compatible to the TTY Controller Module output and the 60 HZ clock cycle conforms to the PDP-11/15 clock rate.

The simple TTY character print program below (used by DEC technicians for diagnostic checks) was loaded into memory (starting address -- 1000) via the console switches. This program was utilized to ensure proper TTY printing of alphabet characters. The Program starts at address 1000 and directs the processor to send the complete keyboard characters/numbers sequence to the TTY. Likewise, proper execution of the program verifies baud rate, clock cycle and serial I/O signal connections. The program performed properly when executed on the PDP-11/15. The program will continue to run until manually stopped.

<u>TTY PRINT CHARACTERS PROGRAM</u>	
<u>ADDRESS</u>	<u>CONTENTS</u>
1000	10037
1001	177566
1002	105737
1003	177564
1004	100375
1005	5200
1006	137
1007	1000

RECONFIGURATION OF PDP-11/15 UNIBUS STRUCTURE

Figure 6 depicts a simplified reconfiguration of the

PDP-11/15 system. The M920 UNIBUS Connector was disconnected from the modified DD11-A Module/EAE Module. The BC11-A cable installed in the last slots (A4/B4) in the ADC module was disconnected and inserted into slots (A4/B4) on the modified DD11-A module. The BC11-A "out" cable from the Dataram DR-103 memory backplane to the control unit was disconnected. An M930 terminator module was installed in the BC11-A "out" cable position on the Dataram backplane. This PDP-11/15 configuration contains only the basic units required for interfacing the RX02 Disk Drive to the system. These elements include the PDP-11/15 processor, CRT/TTY, RX02 Interface Controller and M9312 Hardware Bootstrap Modules, DR-103 Dataram Memory Unit, system power supply and RX02 Disk Drive Unit. UNIBUS troubleshooting and system testing were greatly enhanced with this simplified PDP-11/15 configuration.

Upon verification of a bootable RX02 Disk Drive to the reconfigured PDP-11/15 system, the PDP-11/15 structure was expanded to include the Control Unit, Display Unit, X-Y Plotter and High-speed Paper Tape Reader.

The EAE and ADC modules were installed to the UNIBUS structure via M920 UNIBUS Connector Modules. Power/ground connections were installed on the modules via the power modules on the system power harness. The BC11-A UNIBUS cable was disconnected from the last slots on the modified DD11-A module and installed on the last slots (A4/B4) on the ADC Module. The BC11-A UNIBUS cable connected from the PDP-11/15

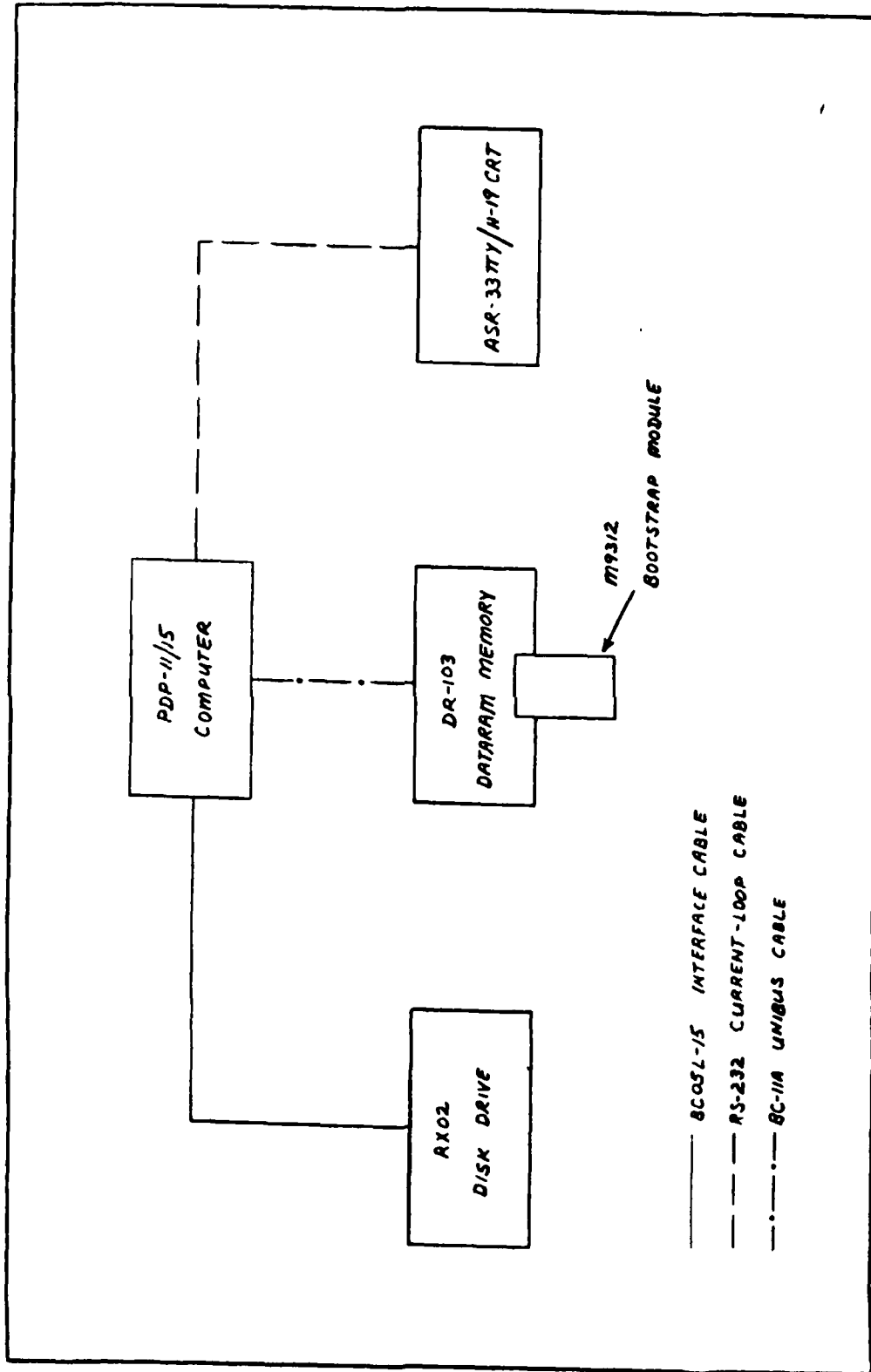

Figure 6. SIMPLIFIED 1923/30 SYSTEM STRUCTURE

computer to the DATARAM Memory Unit was removed. The M930 Bus Terminator card was removed from slots A4/B4 on the Control Unit. The fifteen foot BC11-A cable from the Control Unit (mounted in slots A1/B1 on the DEC UNIBUS bed) was connected to the A4/B4 slots on the ADC module in the PDP-11/15 computer. The remaining BC11-A UNIBUS cable was installed from slots A4/B4 on the DEC UNIBUS bed in the Control Unit to slots A1/B1 on the backplane of the DATARAM Memory Unit. The M9312 Bootstrap Module was left in slots A4/B4 on the Memory Unit backplane. As a result of these changes, the UNIBUS was extended to include all equipment in the 1923/30 system. This enhanced configuration forms the complete system (see Figure 7).

The M9312 Bootstrap Module functions as a hardware bootstrap for the RX02 Disk Drive and as a bus terminator card for the UNIBUS. Consequently, the M9312 Module was inserted in the last position on the UNIBUS (in place of the M930 Terminator Module in the Memory Unit).

#### VERIFICATION OF TTY/SPC BACKPLANE WIRING

The RX02 Disk Drive interfaces to the PDP-11/15 UNIBUS by means of the M8256 Controller Module. The M8256 Module is a quad circuit board designed to be inserted into a single row which includes columns C, D, E and F. The RX02 Disk Drive is a Direct Memory Access (DMA) device. As a result, the circuitry required for the RX02 UNIBUS interface will vary from the standard SPC slots pre-wired to handle TTY and other

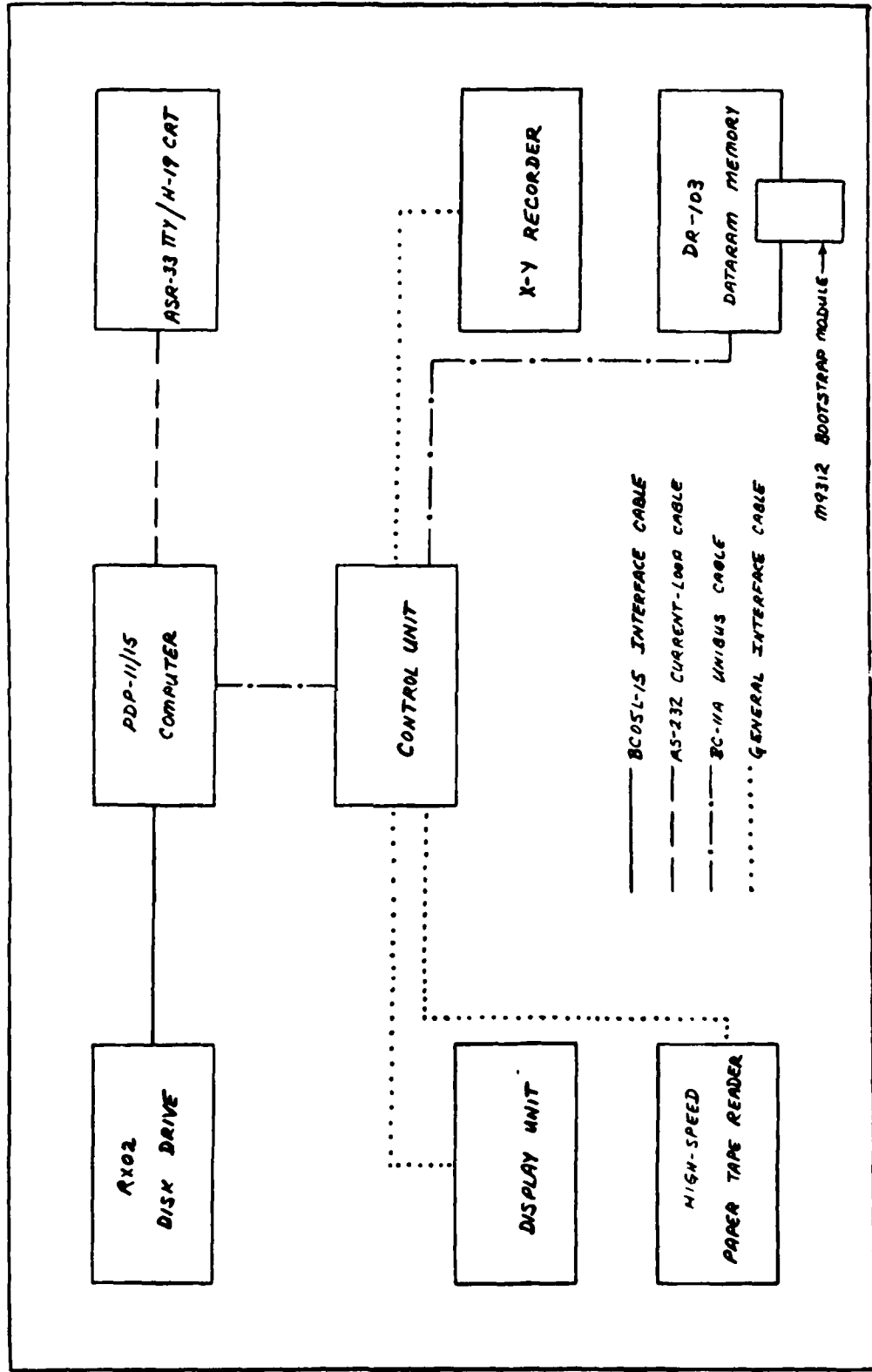
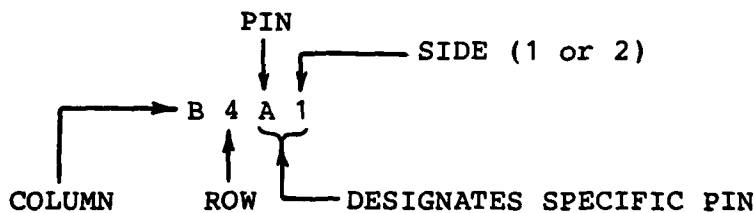

Figure 7. COMPLETE CONFIGURATION FOR 1923/50 SYSTEM

programmable I/O devices. Consequently, wiring into available optional SPC slots (TTY/small peripheral controller spare slots) was verified. Verification of existing SPC slot wiring was essential for future backplane modifications to accommodate the M8256 Interface Module. Rows 13 and 14 (located on the third BB11 Module) in the PDP-11/15 backplane were the only TTY/SPC slot available for verification. The standard DEC UNIBUS wiring/pin configurations expedited identification and verification of UNIBUS signals.

UNIBUS WIRING/PIN CONFIGURATIONS

The UNIBUS wiring/pin configurations are identified by one of two methods. All processor modules, with the exception of the KL11 Teletype Control Modules and other device controller modules, are identified by means of a four-character scheme. The following example represents the location of pin B4A1 (Ref 12:A-1):



The example identifies pin A located on side one of the module, row 4 (sometimes written "04"), and column B.

Figure 8 illustrates the physical layout of the backplane and specific pin locations. Row numbers 5, 10 and

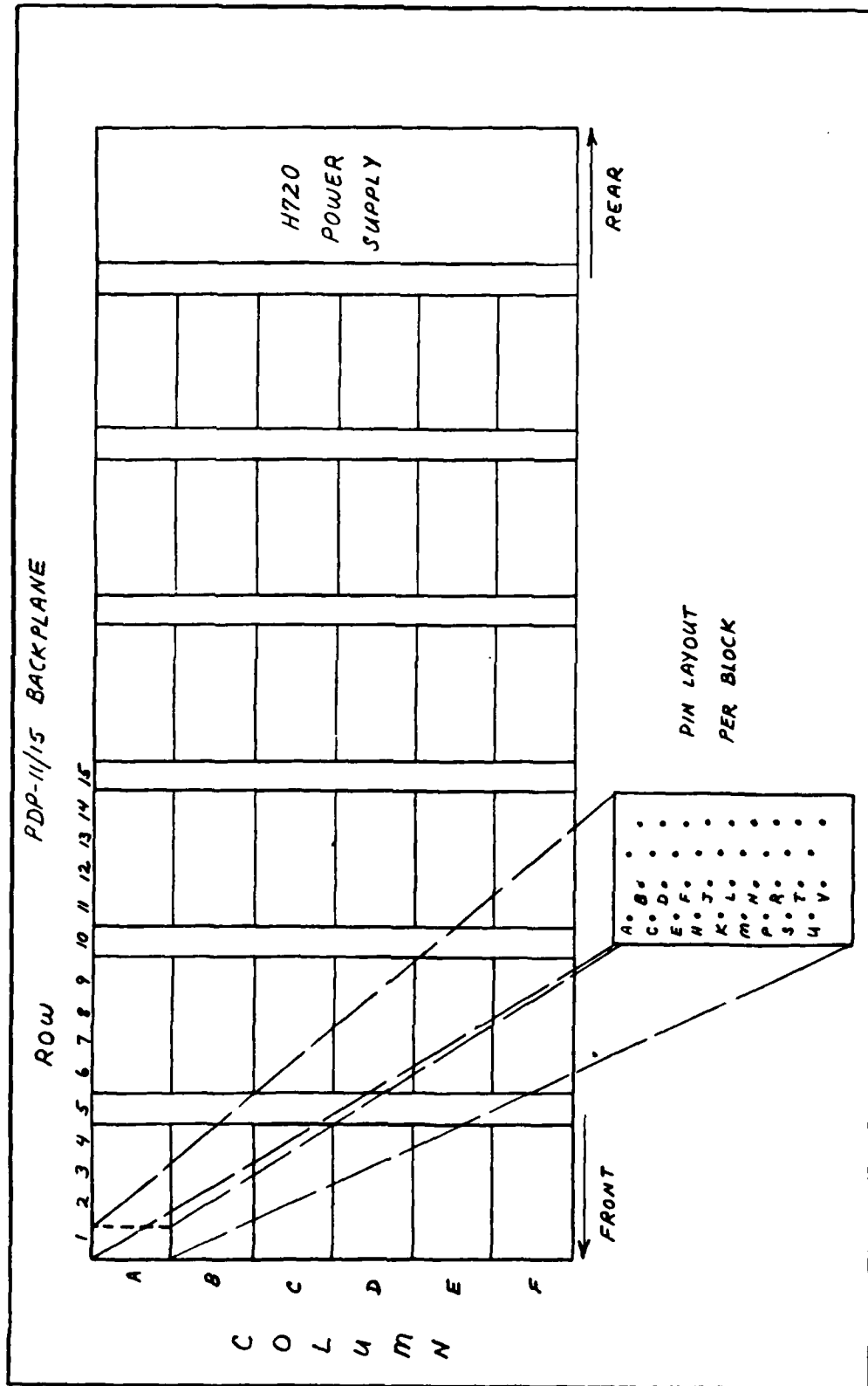
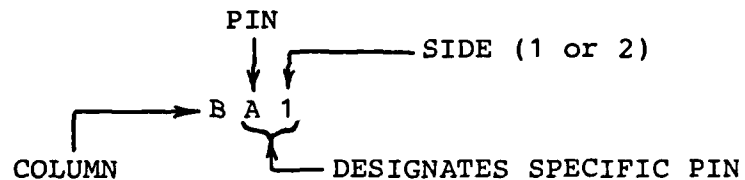

Figure 8. UNIBUS PIN CONFIGURATIONS (REF 12 : A-2)

15 depicted in the figure are taken into account for the numbering sequence but contain no modules or pins.

The KL11 Teletype Controller Modules use a three-character identifications scheme. The following example depicts the three-character scheme:



The example identifies pin A located in column B and on side one of the module. The three-character method eliminates the row identifier. As a result, the KL11 Teletype Controller Module identification conforms to the actual SPC slot (row) configuration (Ref 12:A-1).

#### PDP-11/15 WIRING CONFIGURATION FOR TELETYPE/SMALL PERIPHERAL CONTROLLER (TTY/SPC)

The PDP-11/15 UNIBUS structure carries all 56 UNIBUS signals and 14 grounds. All UNIBUS signals were pre-wired through the PDP-11/15 backplane (columns A and B) and interfaced to other devices in the system by means of the UNIBUS BC11A cable.

All power, ground, ACLO L and DCLO L signals were connected to the TTY/SPC slots (rows 13 and 14 on the system backplane) in accordance with the BB11 power line assignments (see Table VIII, Ref 10:291).

TABLE VIII. BB11 Power Pin Assignments

<u>PIN</u>	<u>POWER</u>	<u>PIN</u>	<u>POWER</u>	<u>PIN</u>	<u>POWER</u>
A1	-15V	H1	-15V	P1	GND
A2	+5V	H2	+5V	P2	LTC L
B1	-15V	J1	-15V	R1	GND
B2	-15V	J2	+5V	R2	ACLO L
C1	-15V	K1	-15V	S1	GND
C2	GND	K2	+5V	S2	DCLO L
D1	-15V	L1	-15V	T1	GND
D2	GND	L2	+5V	T2	+8V
E1	-15V	M1	-15V	U1	GND
E2	GND	M2	+5V	U2	+8V
F1	-15V	N1	GND	V1	GND
F2	GND	N2	-25V	V2	+8V

All UNIBUS lines ( see Table IX, Ref 10:290 ), with the exception of the Bus Grant (BG) Signals, were jumpered from columns A1/B1 to columns A4/B4 on the BB11 module containing the TTY/SPC slots. The four bus grant (BG) signals (BG4, BG5, BG6 and BG7) are used by the processor to determine which device will be granted control of the UNIBUS. The device with the highest bus request (BR) signal will be granted control of the UNIBUS via a bus grant signal. The non-processor request (NPR) signal has precedence over all BR signals. Devices requesting control of the UNIBUS by issuing an NPR signal will gain control of the UNIBUS via a return non-processor grant (NPG) signal. The BG signals (BG4, BG5, BG6 and BG7) on the TTY/SPC slots were pre-wired from the UNIBUS/processor modules to column D of the TTY slot on pins DS2, DP2, DM2 and DK2 respectfully. The signals were jumpered internally by means of the TTY Control Module (see Figure 9) and sent from pins DT2, DR2, DN2 and DL2 onto the spare SPC slot (row 14). The

TABLE IX. UNIBUS Pin Assignments

<u>PIN</u>	<u>SIGNAL</u>	<u>PIN</u>	<u>SIGNAL</u>	<u>PIN</u>	<u>SIGNAL</u>	<u>PIN</u>	<u>SIGNAL</u>
BH2	A00L	BF1	ACL0L	AF1	D06L	BB2	GND
BH1	A01L	AP2	BBSYL	AH2	D07L	BC2	GND
BJ2	A02L	BE2	BG4H	AH1	D08L	BD1	GND
BJ1	A03L	BB1	BG5H	AJ2	D09L	BE1	GND
BK2	A04L	BA1	BG6H	AJ1	D10L	BT1	GND
BK1	A05L	AV1	BG7H	AK2	D11L	BV2	GND
BL2	A06L	BD2	BR4L	AK1	D12L	AA1	INITL
BL1	A07L	BC1	BR5L	AL2	D13L	AB1	INTRL
BM2	A08L	AU2	BR6L	AL1	D14L	BV1	MSYNL
BM1	A09L	AT2	BR7L	AM2	D15L	AU1	NPGH
BN2	A10L	BU2	C0L	AB2	GND	AS2	NPRL
BN1	A11L	BT2	C1L	AC2	GND	AM1	PAL
BP2	A12L	AC1	D00L	AN1	GND	AN2	PBL
BP1	A13L	AD2	D01L	AP1	GND	AA2	+5V
BR2	A14L	AD1	D02L	AR1	GND	BA2	+5V
BR1	A15L	AE2	D03L	AS1	GND	AR2	SACKL
BS2	A16L	AE1	D04L	AT1	GND	BF2	DCL0L
BS1	A17L	AF2	D05L	AV2	GND	BU1	SSYNL

signals entered the spare SPC slot on pins DS2, DP2, DM2 and DK2, and were returned to the UNIBUS (Ref 8:16).

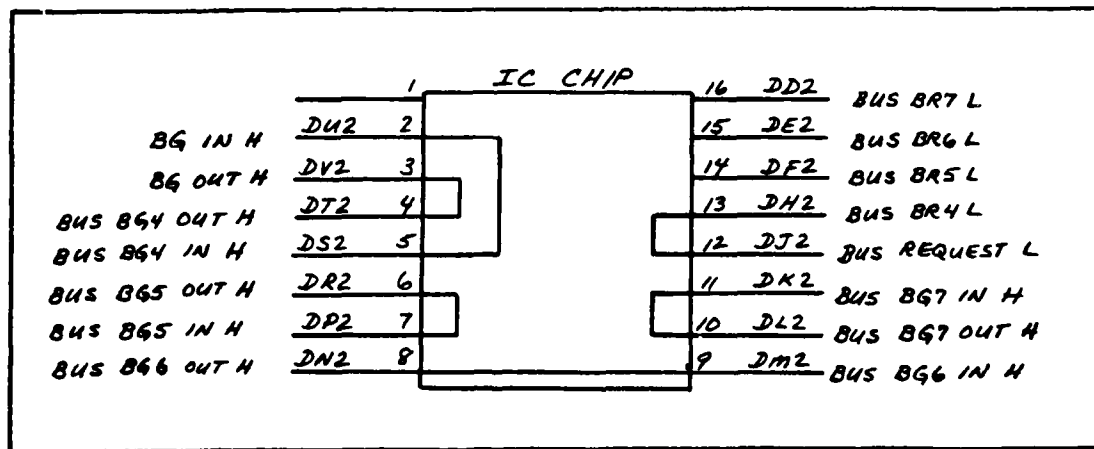

Figure 9. Priority Jumper Plug for TTY

Figure 9 depicts the jumper wiring for a priority four (PR4) device like the ASR-33 TTY. The jumper configuration sends

out a bus BR4 signal on the bus request line for the TTY device. The priority plug accepts only bus BG4 signals for the activation of TTY circuitry. All other Bus Grant (BG) lines are sent to the next device on the UNIBUS.

Bus Grant Continuity (G727) cards were inserted into column D of the spare SPC slot in order to continue the daisy-chain of Bus Grant signals. The G727 card jumpers pins DS2, DP2, DM2 and DK2 to pins DT2, DR2, DN2 and DL2 respectively. As a result, Bus Grant signals pre-wired to empty SPC slots will be returned to the UNIBUS without any discontinuity. Failure to insert G727 cards in column D of empty SPC slots will make the UNIBUS inoperative. Discontinuities in the chain of UNIBUS signals will result in inoperative front console controls and lights.

All UNIBUS signals (see Figures 10 and 11), with the exception of the NPG signal, were pre-wired into their appropriate pin locations on the TTY/SPC slots (rows 13 and 14). The PDP-11/15 was not pre-wired to handle devices that require NPR/NPG signals. NPR/NPG devices normally have a priority of five, six or seven. The TTY/SPC slots were pre-wired to handle priority four devices. Consequently, the NPG line on the TTY/SPC slots was not pre-wired to the UNIBUS (see Figures 10 and 11).

#### RX02 DISK DRIVE INTERFACE

##### INSTALLATION OF RX02 DISK DRIVE UNIT

The High-speed Paper Tape Reader, located



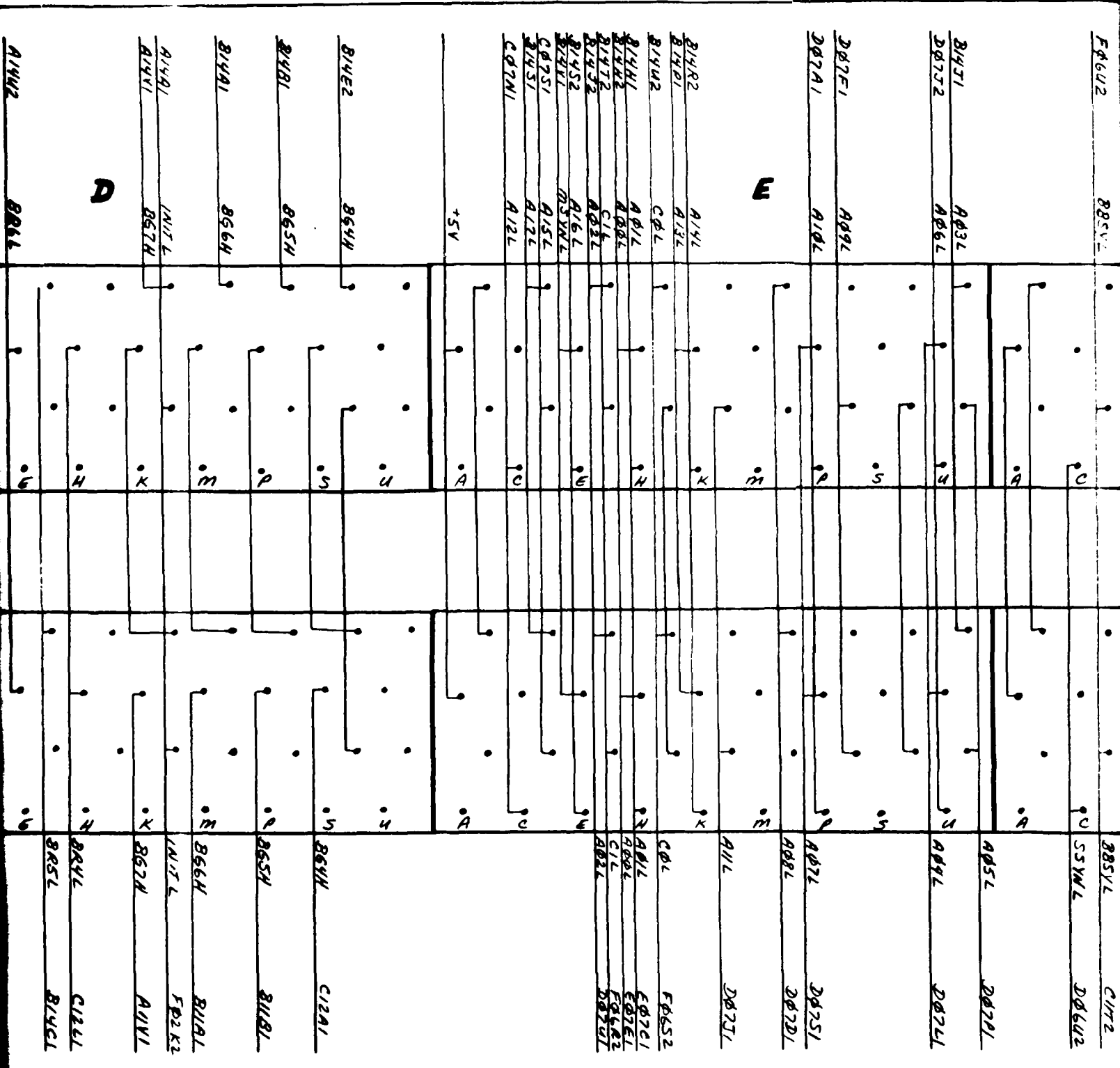

Figure 10. TTY/SPC Input and Output Signals on Backplane

*[Handwritten signature]*

SPARE  
SPC  
SLOT  
(ROW 14)

TTY  
SPC  
SLOT  
(ROW 13)

F02K1 SACK L A11R2

F02L1 SACK L E0751

F03L1 SACK L C06A1

F03L2 SACK L F07M1

F04L1 SACK L E01H1

F04L2 SACK L C12M1

F05L1 SACK L E07M1

F05L2 SACK L E07K1

F06L1 SACK L B05L

F06L2 SACK L C11T2

F07L1 SACK L D06U2

F07L2 SACK L D06U2

F08L1 SACK L D07D1

F08L2 SACK L D07D1

F09L1 SACK L A11L

F09L2 SACK L D07J1

F10L1 SACK L C0L

F10L2 SACK L F05S2

F

E

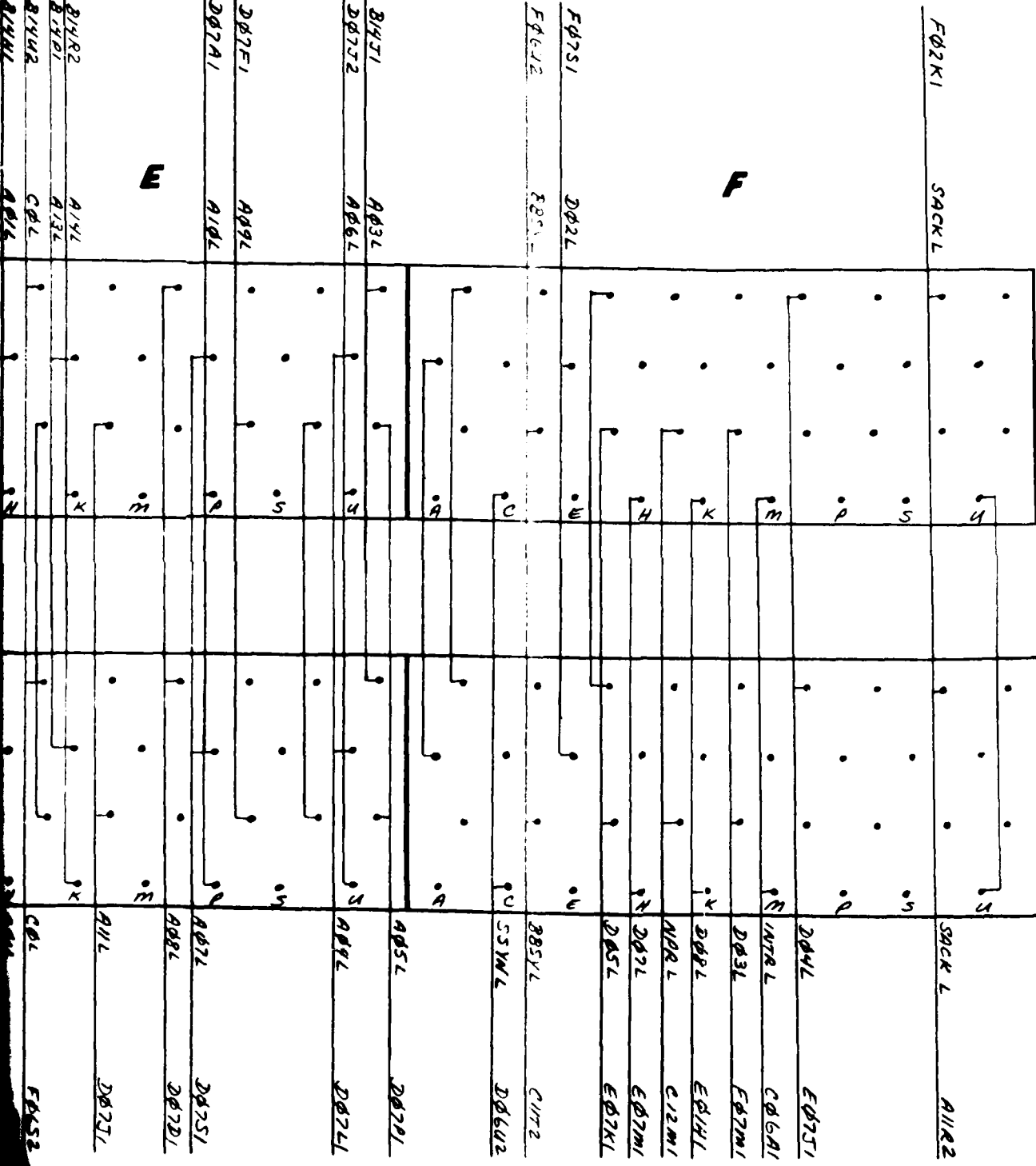

3



**D**

**E**

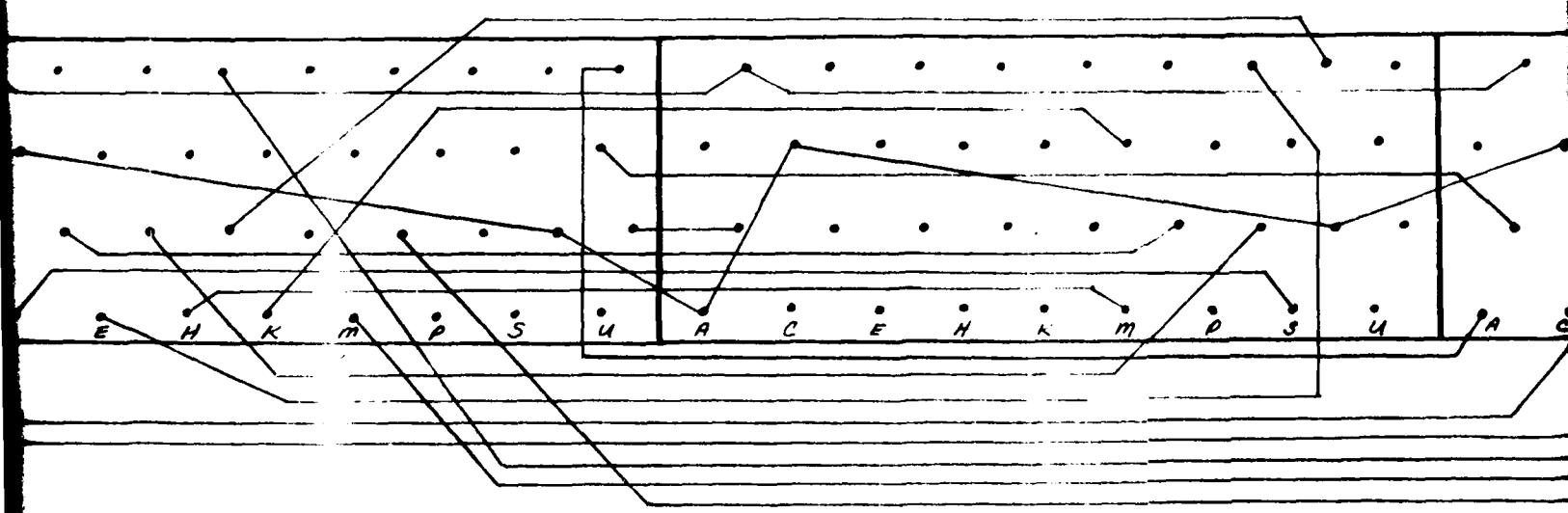
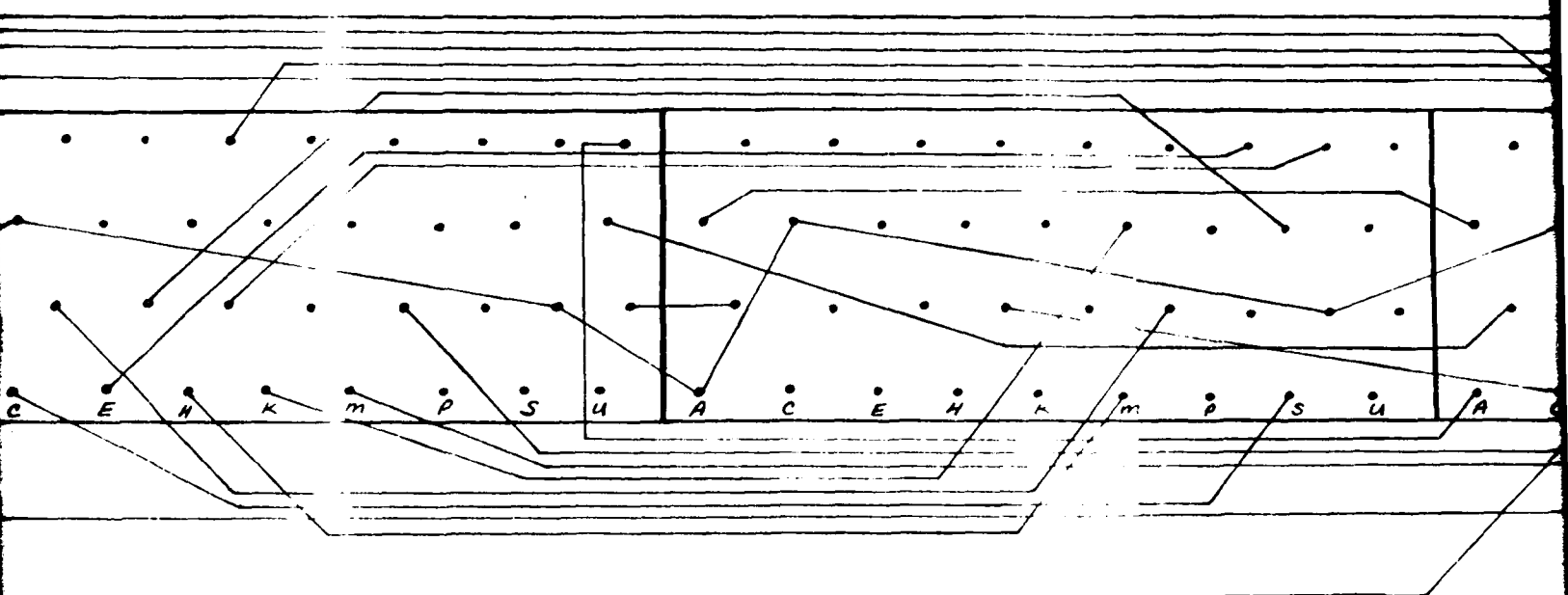

Figure 11. TTY/SPC Internal Jumpers on Backplane

1

2

**E**

**F**

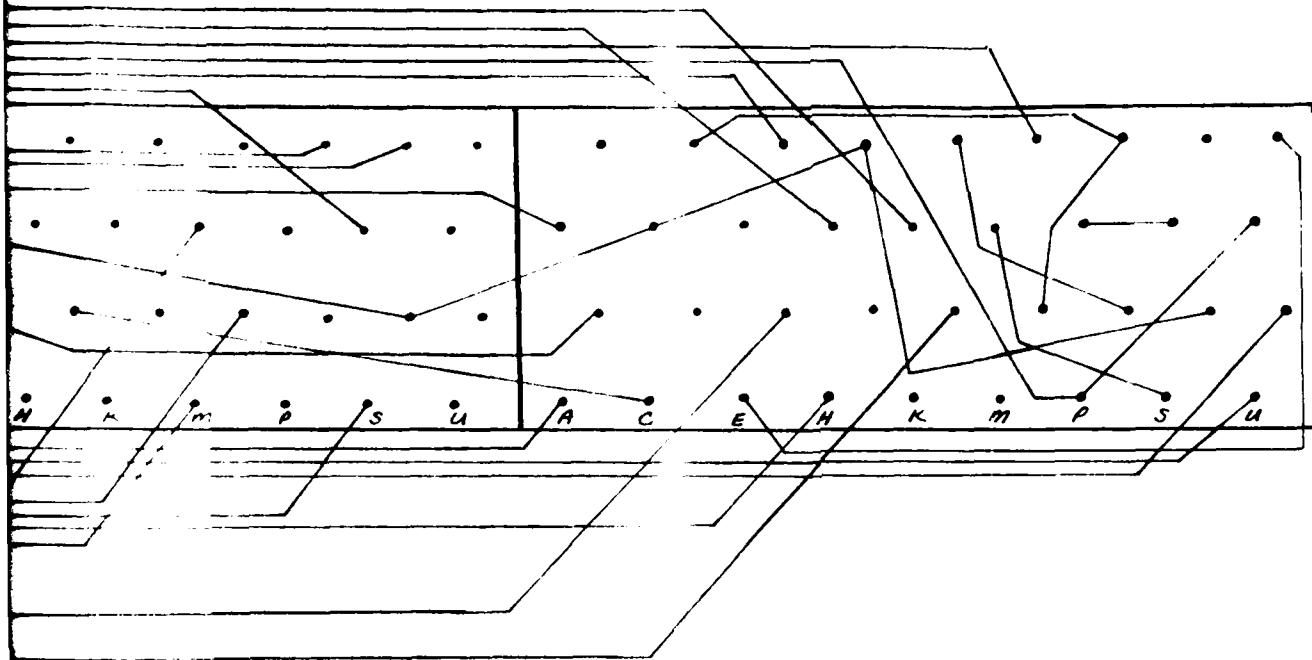

SPARE  
SPC  
SLOT  
(ROW 14)

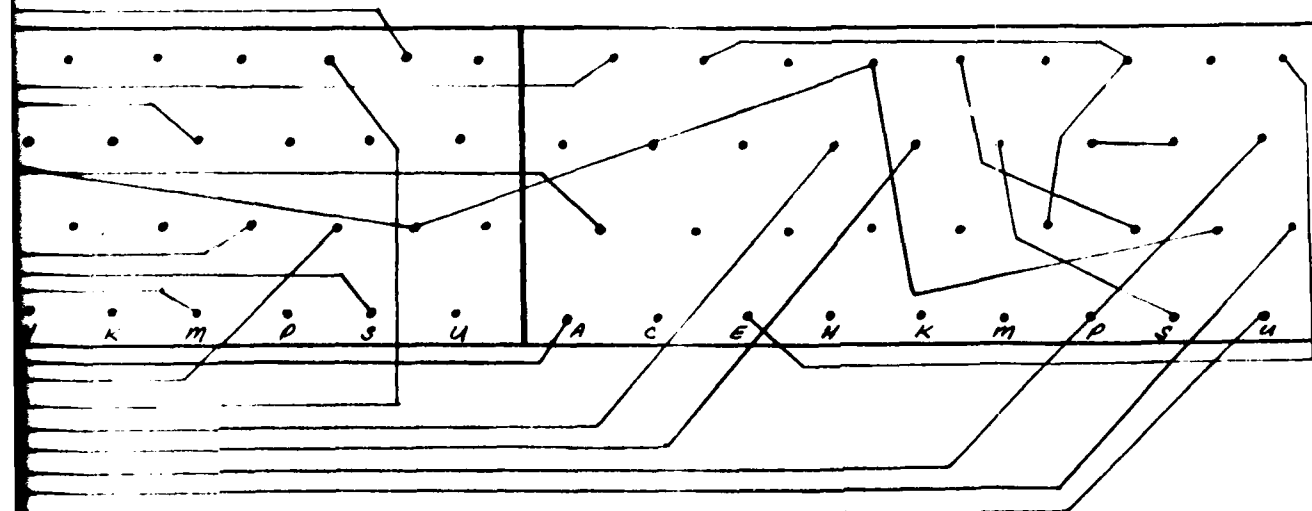

TTY  
SPC  
SLOT  
(ROW 13)

directly above the PDP-11/15 computer, was removed and the RX02 Disk Drive was mounted in the same location via the RX02 cabinet-mountable installation kit. The RX02 power cable was installed on the 1923/30 power strip in the cabinet backplane. The BC05L-15 standard interface cable was connected from the M7744 CPU Controller Module in the RX02 to the M8256 Interface Controller Module in the PDP-11/15 backplane. The BC05L-15 cable was connected to each module with the red stripe on the cable toward the center of the card. This convention ensured that signal continuity was maintained between modules (Ref 14:4).

The S1 (controller configuration) switch on the M7744 module in the RX02 Disk Drive has three modes of operation. The three possible configurations for an RX02 Disk Drive are (Ref 13:2-4):

<u>INTERFACE</u>	<u>DESCRIPTION</u>	<u>S1 SETTINGS</u>	
		<u>S1-1</u>	<u>S1-2</u>
RX211/RXV21	PDP-11/LSI-11 Double Density	OFF	ON
RX8E/RX11/RXV11	PDP-8/PDP-11/LSI-11 Single Density	ON	OFF
RX28	PDP-8 Double Density	OFF	OFF

#### INSTALLATION OF KF11-A MULTIPLE BUS PRIORITY MODULE

The RX02 Disk Unit is a priority five (PR5) device. The ASR-33 TTY/Heathkit H-19 CRT units are priority four (PR4) devices. Multiple bus priority control logic is required to properly allocate device control of the PDP-11/15 UNIBUS. The KF11-A Multiple Bus Priority Module provides this control logic.

### GENERAL DESCRIPTION OF KF11-A

The KF-11A Multiple Bus Priority Option provides four interrupt levels (4,5,6 and 7) for the PDP-11/15 processor. The system is pre-wired to service only Bus Grant four (BG4) signals when the KF11-A option is not installed. When the KF-11A option is installed, the KC11 processor in the PDP-11/15 computer can service BG4 through BG7 and Bus Request four (BR4) through BR7 signals. The console non-processor request flag (CNPRF), console bus request flag (CBRF) and non-processor request flag (NPRF) signals remain under control of the M7216 Priority and Control Module. The KC11 processor backplane is already pre-wired for installation of the KF11-A option (Ref 4:3-1).

### BASIC OPERATION OF KF11-A

All devices connected to the system UNIBUS compete for use of the bus. When a device requires use of the bus, it issues a bus request (BR) signal to the processor. The processor converts all asynchronous device requests to synchronous requests. The KF11-A accepts all four bus request signals, determines which request has a higher priority, and then issues a processor bus grant signal to the device with the highest priority. Figure 12 depicts the control circuitry on the M7218 Multiple Bus Priority Module. The figure traces the flow of BR/BG signals for all controller devices. Bus Request signals are channeled through a series of logic gates in order to determine which device has the highest BR signal.

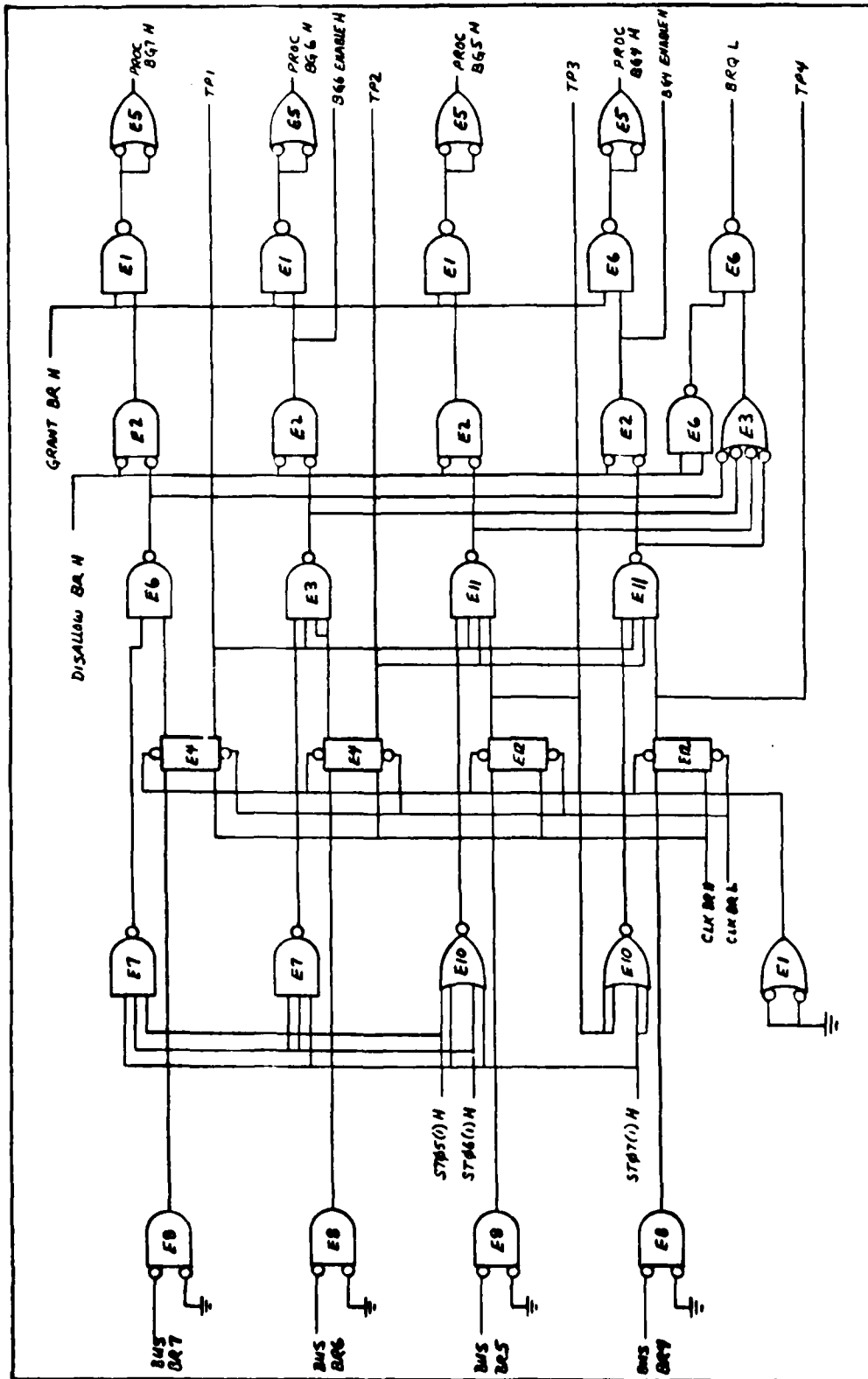

Figure 12. BUS REQUEST CIRCUITRY FOR M7218 MULTIPLE BUS PRIORITY MODULE (REF 3)

The following list (Ref 4:3-4) describes the general control signals produced by the KF11-A option:

<u>SIGNAL NAME</u>	<u>DESCRIPTION</u>
KBR-2 PROC BG7 H	Bus signal indicating bus control is on level seven
KBR-2 TP1	Test Point used to monitor BR7 flip-flop
KBR-2 PROC BG6 H	Bus signal indicating bus control is on level six
KBR-2 BG6 Enable H	Test Point indicates selection of BG6 for bus release
KBR-2 TP2	Test Point used to monitor state of BR6 Flip-Flop
KBR-2 PROC BG5 H	Bus signal indicating bus control is on level five
KBR-2 TP3	Test Point used to monitor state of BR5 flip-flop
KBR-2 PROC BG4 H	Bus signal indicating bus control is on level four
KBR-2 BG4 Enable H	Test Point indicating selection of BG4 for bus release
KBR-2 TP4	Test Point used to monitor state of BR4 flip-flop
KBR-2 BRQ L	Signal indicating a bus request was issued and that the bus request is of a higher priority than ones currently in the processor

#### PROCEDURES FOR KF-11A INSTALLATION

Two procedures were required to install the KF11-A option. The M7218 Bus Request Module was inserted into the pre-wired slot B6 of the KC11 processor unit (see Figure 2) and the J2/J3 jumpers on the M7216 Priority/Control Module were removed (see Figure 13). Removal of the J2 and J3 jumpers on the M7216 Module disabled the BRQ L and PROC BG4 H signals generated on that module. The BRQ L and PROC BG4 H signals were generated on the M7218 Module when it was installed. The J1 and J4 jumpers on the M7216 Module are

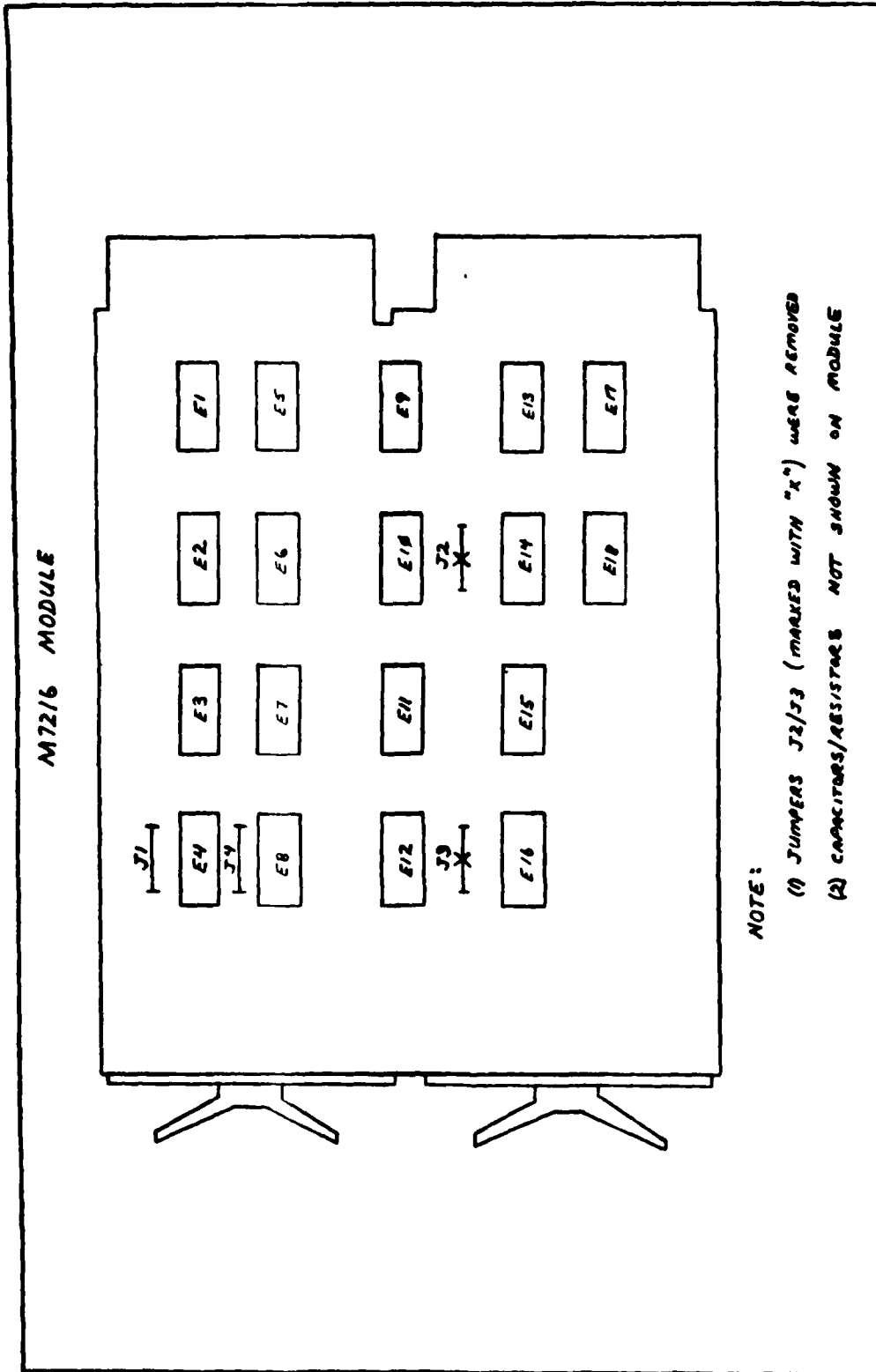

Figure 13. J2/J3 JUMPERS FOR M7216 PRIORITY/CONTROL MODULE

removed when the power fail/restart KP11-A option is installed. The KP11-A option was not required and consequently not installed on this system (Ref 4:2-1). As a result, the J1 and J4 jumpers were left installed on the M7216 Module.

MODIFICATION OF KP11-A MODULE

The system M7218 Multiple Bus Priority Module was built to conform to Digital Equipment specifications and standards. The following list indicates DEC recommended IC chips for the M7218 Module and those actually installed:

<u>DEC IC CHIPS</u>	<u>IC CHIPS INSTALLED</u>
DEC 380	SP380A
DEC 74H10N	SN74H10N
DEC 74H00N	SN74H00N
DEC 7402N	SN7402N
DEC 74H20	SN74H20N
DEC 74H74N	SN74H74N
DEC 8881	SN7401N
DEC 74H50N	SN74H50N

The SN7401N IC Chip used as a replacement for the recommended DEC 8881 IC Chip contains quadruple 2-input positive-nand gates with open collector-outputs (Ref 22:5-1). In open-collector circuits a pull-up resistor is required to bring the output to a high state (Ref 19:126). Pull-up resistors for the SN7401N IC Chip were not installed on the M7218 Module. As a result, low input signals to the SN7401N IC Chip produced an output voltage that was neither high nor low. To correct this problem, the SN7401N IC Chip in IC

position E5 (see Figure 14) was replaced with an SN74LS00N IC Chip which contains quadruple 2-input positive-nand gates (Ref 22:5-6) and requires no pull-up resistors. This modification corrected the high/low signal output problem without adding any pull-up resistors to the module. The input/output pin locations on the SN74LS00N IC Chip were different from the original SN7401N IC Chip used. As a result, the following changes were made to existing backplane wiring on the M7218 Module IC bed containing the SN74LS00N IC Chip:

WIRING REMOVED

<u>FROM</u>	<u>IC POSITION</u>	<u>TO</u>	<u>IC POSITION</u>
PIN 2	E5	PIN 3	E5
PIN 2	E5	PIN 8	E6
PIN 8	E5	PIN 9	E5
PIN 8	E5	PIN 8	E1
PIN 11	E5	PIN 12	E5
PIN 11	E5	PIN 6	E1
PIN 5	E5	PIN 6	E5
PIN 5	E5	PIN 3	E1

WIRING INSTALLED

<u>FROM</u>	<u>IC POSITION</u>	<u>TO</u>	<u>IC POSITION</u>
PIN 8	E6	PIN 2	E5
PIN 2	E5	PIN 1	E5
PIN 8	E1	PIN 10	E5
PIN 10	E5	PIN 9	E5
PIN 6	E1	PIN 13	E5
PIN 13	E5	PIN 12	E5
PIN 3	E1	PIN 5	E5
PIN 5	E5	PIN 4	E5

Figure 14 indicates the IC position numbers for each IC Chip on the M7218 Module. The IC position numbers in Figure 14

M7218 MODULE

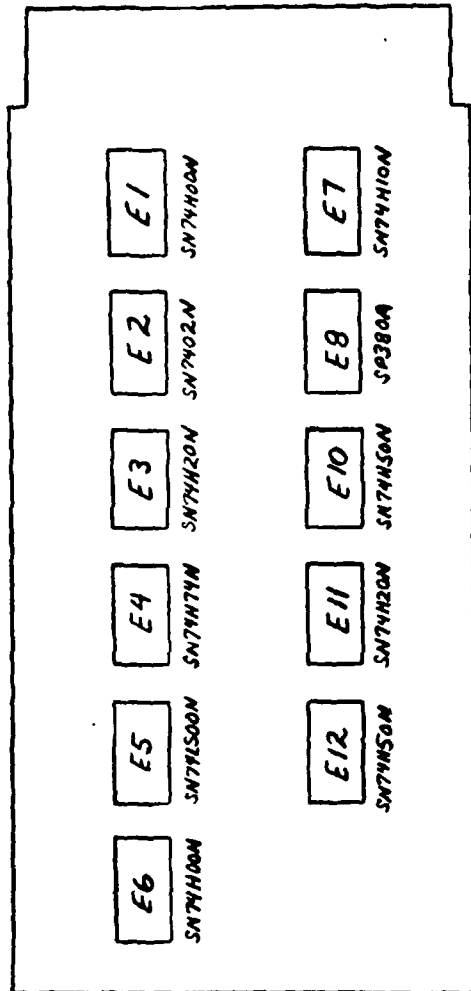

NOTE :

- (1) CAPACITORS NOT SHOWN ON MODULE
- (2) IC CHIP LOCATIONS ON ABOVE MODULE  
DIFFERS FROM IC CHIP LOCATIONS  
ILLUSTRATED IN KCII PROCESSOR  
ENGINEERING DRAWINGS

Figure 14. IC POSITION NUMBERS FOR M7218 MODULE

differ from the IC position numbers for the M7218 Module listed in the KC11 processor engineering drawings. This variation in chip position identification was a result of different physical layouts for each module.

#### INSTALLATION OF KW11-L LINE TIME CLOCK

The KW11-L Line Time Clock is an option module (M787) which is wired to column B, row twelve of the KC11 processor. The KW11-L accurately divides time into intervals for more efficient use of the PDP-11/15 processing time. The KW11-L option provides clocked intervals (50/60 HZ) for various hardware/software equipment. The PDP-11/15 computer operates on a line frequency of 60 HZ. The KW11-L clock intervals are determined by the line frequency of the host computer. Installation of the KW11-L clock elevates the line time clock level of the PDP-11/15 to that of a PDP-11/20 system. The KW11-L clock has a BR6 priority level, vector address of 100, 60 HZ clock interval rate (with 50 HZ capability) and interrupt/noninterrupt operational modes (Ref 4:A-1).

The KW11-L Line Time Clock was installed in the PDP-11/15 processor to provide the necessary 60 HZ clock intervals required for operation of a floppy disk RT.11 software operating system. Figure 15 depicts wiring modifications made to the PDP-11/15 backplane (column B, rows 12 and 14, and column D, row 14) for proper installation of the KW11-L Line Time Clock. Installation of the KW11-L Clock (at priority

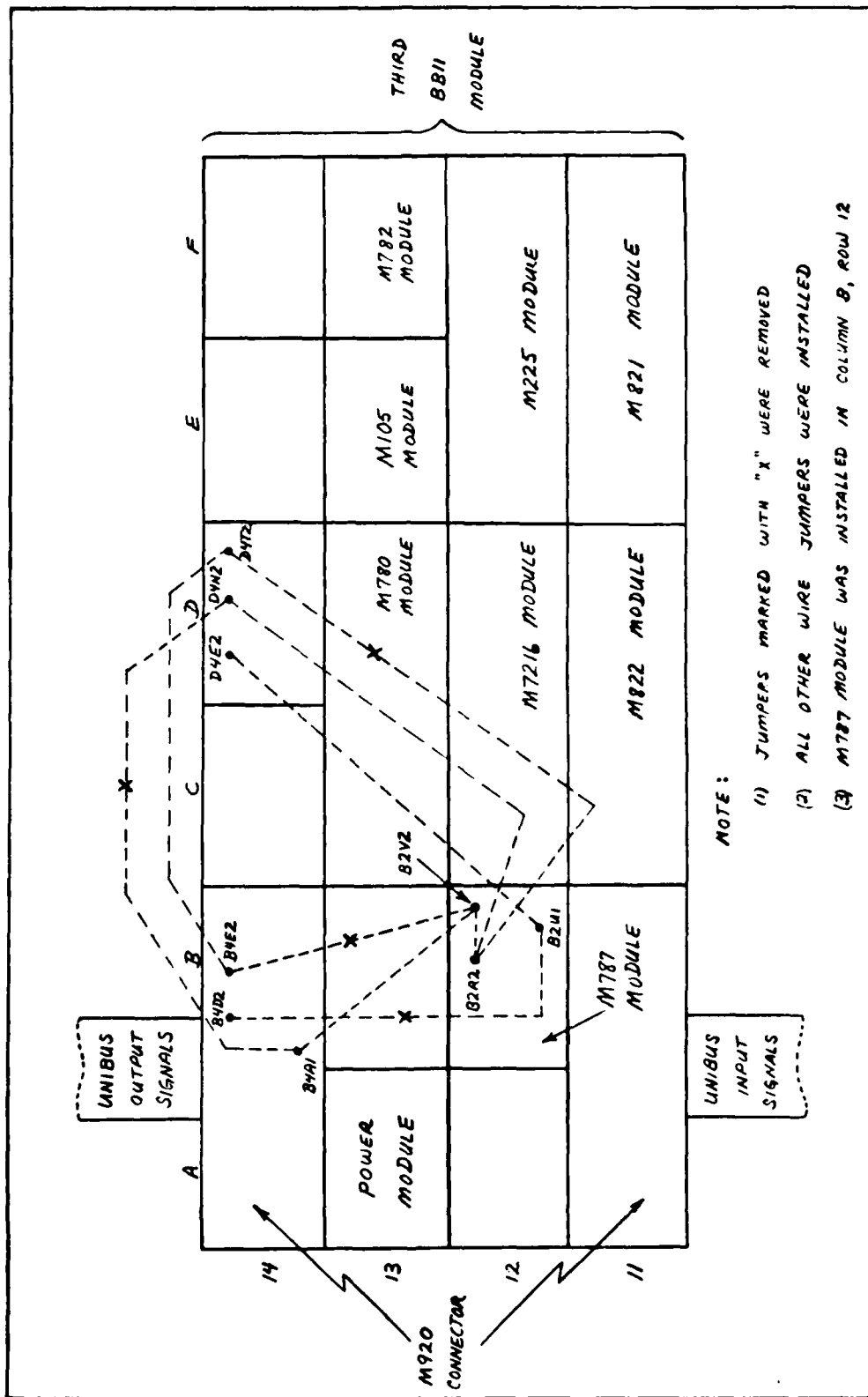

Figure 15. WIRING MODIFICATIONS FOR INSTALLATION OF KW1-1 TIME LINE CLOCK (REF 4.1A-1)

BR6) had no effect on attempts to bootstrap the RT.11 operating system. The KW11-L Clock was rewired for a BR5 priority. Likewise, the clock (wired for BR5) did not effect RT.11 floppy disk bootstrap operations.

#### MODIFICATION/INSTALLATION OF DD11-A MODULE

A DD11-A module is a pre-wired system unit designed for mounting up to four small peripheral devices. The DD11-A is similar in design to a BB11-A processor module. DD11-A and BB11-A modules are installed in the PDP-11/15 backplane via two mounting screws. All UNIBUS signals enter the DD11-A/BB11-A modules in slots A1/B1 and exit on slots A4/B4 via M920 UNIBUS connector cards. Both modules are powered by the system power harness installed in slot A3. The DD11-A module is pre-wired differently from the BB11-A module.

The addition of a Direct Memory Access (DMA) device, like the RX02 Disk Drive, requires that an SPC slot on the DD11-A be modified prior to installation of the device. The major wiring change required for this modification entailed re-wiring the UNIBUS NPG signal. The NPG signal was jumpered from column A1 on the DD11-A module to column C1 on the DD11-A module. The signal was daisy-chained from column C1 through column C4 and then returned to the UNIBUS (see Figure 16). The modification enables DMA devices to operate using the NPG/NPR bus signals for DMA data transfers. The "NPG IN" signal enters on pin CA1 and the "NPG OUT" signal exits on pin CB1 for each SPC slot (row) of the DD11-A module. The "NPG

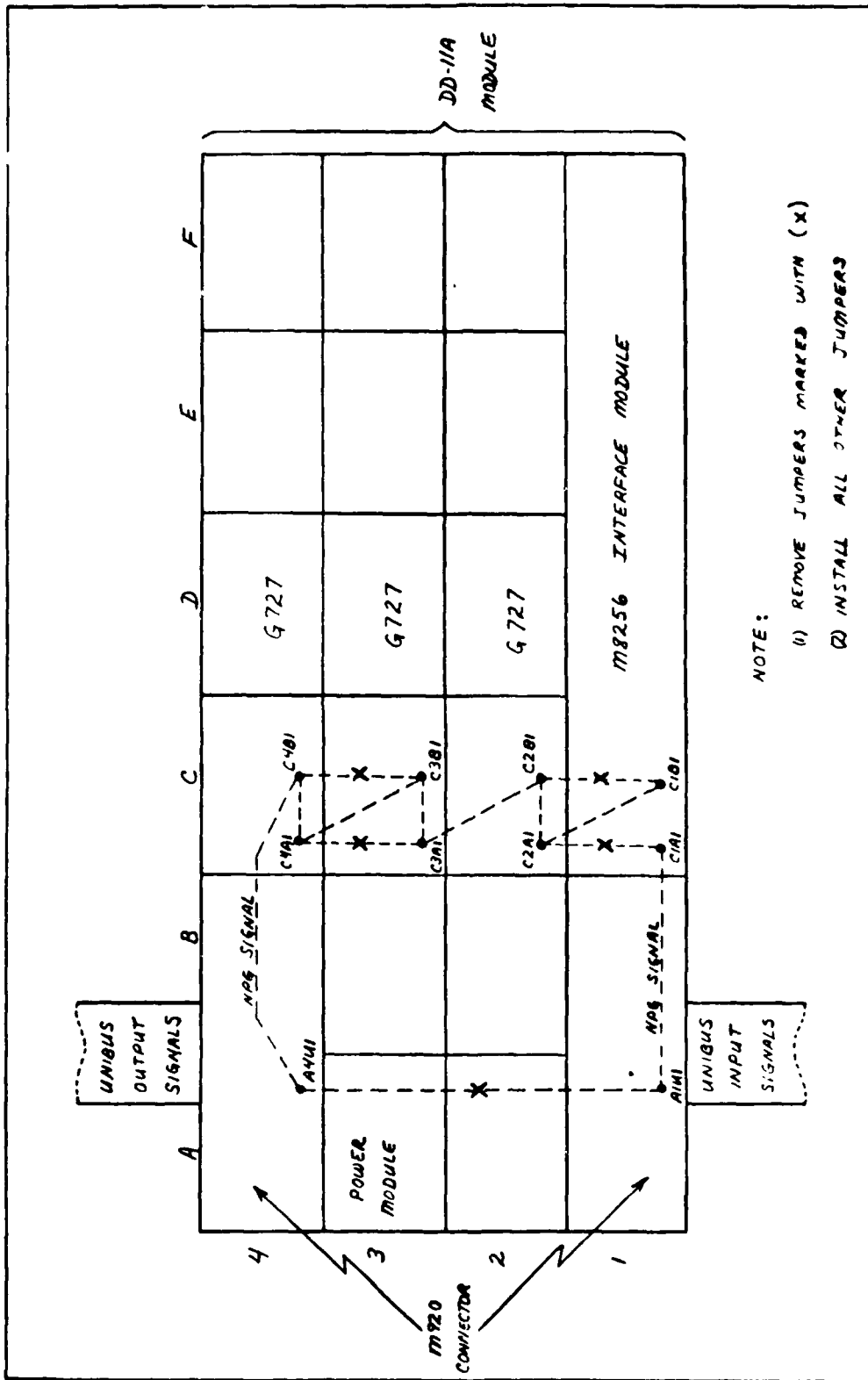

Figure 16. CONVERSION OF DD-11A MODULE FOR DIMA DEVICES

IN" and "NPG OUT" signals are internally jumpered on the device controller module inserted in the SPC slot. Consequently, the CA1-CB1 jumper of column C1 was removed when the M8256 RX02 Disk Controller Module was installed in that particular SPC slot. The remaining jumpers from CA1 to CB1 in columns C2, C3 and C4 were left installed to ensure NPG signal continuity. Bus Grant Continuity Modules (G727) were installed in column D of each spare row on the module to ensure continuity of the BG signals. Additionally, pre-wired jumpers connecting CA1 and CB1 pins in adjacent rows were removed. Removal of these jumpers ensured proper flow of NPG signals from one device to the next device along the module column.

The modified DD11-A module was mounted between the third processor BB11-A module and the pre-wired EAE module via two mounting screws (see Figure 2). Connection to the UNIBUS was achieved by installing two M920 connector modules in slots A1/B1 and A4/B4. Power to the module was achieved by installing a power module (from the power harness) to slot A3. Only four-wide modules (modules configured for entire SPC slot) should be installed on this modified DD11-A module. Wiring configurations may not be consistent with modules that are not four-wide in design.

#### INSTALLATION OF M8256 CONTROLLER MODULE

The M8256 Interface Controller Module for the RX02 Disk Drive was mounted on the modified DD11-A module (column C, D,

E and F, row 1) in the PDP-11/15 backplane. The M8256 Module is designed for use with a double density formatted media. Operation on single density formatted floppy disks would require a different interface module (M7846) and different M7744 module settings (for RX11 configuration) in the RX02 unit. The vector address (264 octal) and UNIBUS address (177170 octal) for the RX02 were set via the 7952 and 7942 switches located on the module (Ref 13:2-4). The settings were as follows:

<u>7942 SWITCH</u>	<u>7952 SWITCH</u>
V2 - SW1 ON	A3 - SW1 OFF
V3 - SW2 OFF	A4 - SW2 OFF
V4 - SW3 ON	A5 - SW3 OFF
V5 - SW4 ON	A6 - SW4 OFF
V6 - SW5 OFF	A7 - SW5 ON
V7 - SW6 ON	A8 - SW6 ON
V8 - SW7 OFF	A9 - SW7 OFF
	A10 - SW8 OFF
	A11 - SW9 OFF
	A12 - SW10 OFF

The RX02 Disk Drive Unit is a priority five (PR5) device. Consequently, the priority jumper plug (see Figure 17) on the M8256 module is wired to produce a bus request five (BR5) signal and gain control of the UNIBUS when a bus grant five (BG5) signal is received from the processor. The pre-wiring installation of the "NPG IN" signal to pin CA1 and "NPG OUT" signal to pin CB1 on the modified DD11-A module ensures that the RX02 will receive control of the UNIBUS when the device issues an NPR signal, regardless of other BG signals at the time of request.

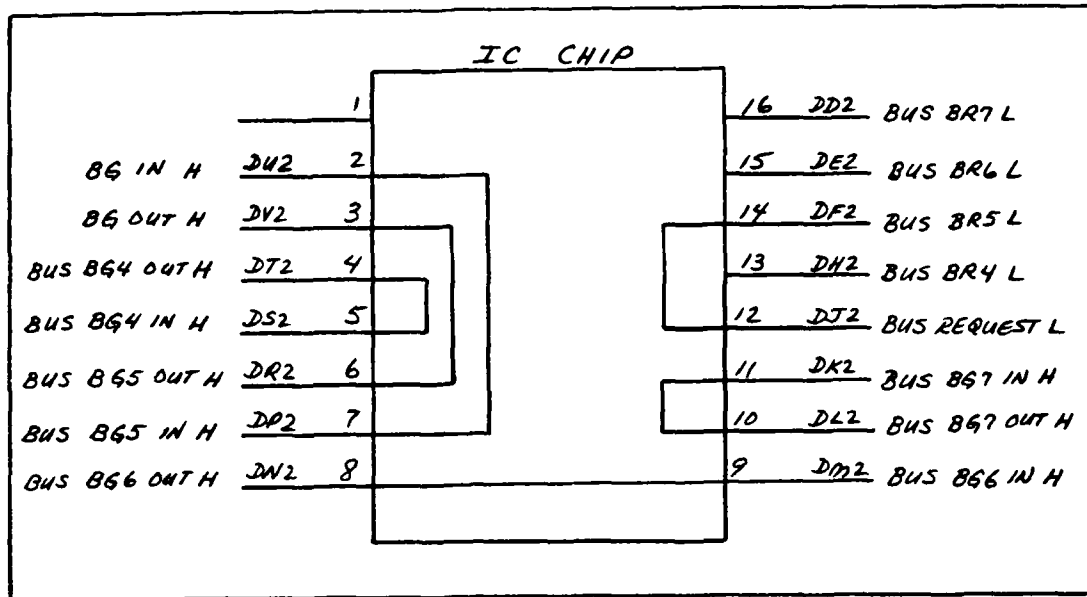

Figure 17. Priority Jumper Plug for RX02

INSTALLATION/OPERATION OF SOFTWARE OPERATING SYSTEM

The RX02 Disk Drive booted-up via a DEC XXDP.+ DY monitor operating system (DEC diagnostics installed on eight inch double density formatted floppy disk). The XXDP.+ is a monitor file with limited monitor/utility commands. The procedure for booting the XXDP.+ monitor file is as follows:

BOOT-UP/OPERATING PROCEDURES

1. Power up PDP-11/15 system (system power on, PDP-11/15 power on, memory power on, TTY on-line).
2. Load eight inch floppy disk (with XXDP.+ diagnostics monitor file in DY0 slot).
3. Press PDP-11/15 Console HALT switch.
4. Load address 173004 into PDP-11/15 console

register.

5. Pull up ENABLE switch on console.

6. Press START switch on console.

7. TTY will print:

```
CHMDYB2 XXDP.+ DY MONITOR  
BOOTED VIA UNIT 0  
28K UNIBUS SYSTEM
```

8. Press carriage return on TTY when prompted by the following questions:

- a. ENTER DATE (DD-MMM-YY):
- b. 50 HZ?
- c. LSI?

9. TTY will print:

```
THIS IS XXDP.+ TYPE "H" OR "H/L" FOR DETAILS
```

10. Type in "H" and carriage return to enter the HELP.TEXT file. All monitor commands/utility commands are explained in detail.

The DEC RT.11 operating system offers adequate monitor commands/utility programs to perform paper tape file transfers to disk (via the PIP utility program) and LOAD/BOOT procedures to enable operation of the system PANEL 30/ TSL 30 operating systems, overlay programs and diagnostic routines. Transfer of paper tape programs to a floppy disk media would significantly upgrade the system. The DEC RT.11 operating system being utilized was formatted double density on eight inch floppy disk. The following files were required on the disk for boot-up/file transfers/monitor commands (Ref 6:1-10):

<u>FILENAME</u>	<u>DESCRIPTION</u>
RT.11SJ.SYS	Operating System
SWAP.SYS	Buffer file
DY.SYS	Device handler for RX02
PR.SYS	Device handler for High-speed Paper Tape Reader
TT.SYS	Device handler for TTY/CRT
DIR.SAV	Directory File
DUP.SAV	Duplication File
PIP.SAV	Peripheral Interchange Program File

Under the current configuration of the 1923/30 Time-Series Analysis System (including all hardware), the DEC RT.11 operating system would not boot-up. Upon completion of normal start procedures, the system halted and the TTY was disabled.

#### INSTALLATION OF M9312 BOOTSTRAP MODULE

The M9312 hardware bootstrap module was installed on the output (A4/B4) slots of the Dataram DR-103 memory unit for the simplified PDP-11/15 system configuration and on the last UNIBUS slot in the Control Unit. The M9312 module was configured to mount in the UNIBUS in place of a M930 Bus Terminator card. The UNIBUS signals on slots A1/B1 or A4/B4 are compatible with the M9312 pin configuration. The M9312 and M930 perform the same function of terminating the UNIBUS signals. The UNIBUS will not operate properly, however, with the M9312 module installed in place of the first M930 Terminator card on the UNIBUS. Consequently, the only position suitable for the M9312 module is at the end of the UNIBUS.

The M9312 has several jumpers which must be set for

proper operation. The following is a list of all required jumpers (Ref 5:5-6).

<u>JUMPER NAME</u>	<u>SETTING</u>	<u>FUNCTION</u>
W1	IN	Pull up for Bus BG6 H (when IN)
W2	IN	Pull up for Bus BG7 H (when IN)
W3	IN	Pull up for Bus NPG H (when IN)
W4	IN	Pull up for Bus BG5 H (when IN)
W5	IN	Pull up for Bus BG4 H (when IN)
W6	OUT	Buf Vector L (IN for PDP-11/70)
W7	IN	Reserved (always IN)
W8	IN	LO ROM enable (when OUT)
W9	IN	W9 and W10 are for power-up boot
W10	IN	(IN for all CPU's except PDP-11/60)
W11	OUT	W11 and W12 are for power-up boot
W12	OUT	(IN for all CPU's except PDP-11/60)

Jumpers W1 through W5 must be installed in order to pull up all bus BG/NPG signals on the PDP-11/15 UNIBUS. The Bootstrap module would not boot the operating system when the LO ROM was disabled. Consequently, W8 was left out in order to enable the LO ROM on the bootstrap module. The M9312 "S1" switch settings were set as follows (Ref 5:18):

<u>S1 SWITCH</u>	<u>SETTING</u>
1	ON
2	OFF
3	OFF
4	OFF
5	OFF
6	OFF
7	ON
8	OFF
9	OFF
10	OFF

The M9312 will accommodate a diagnostic ROM and a device ROM.

Consequently, a diagnostic ROM (248F1) was installed in module location E20 and the bootstrap ROM (811A9) was installed in module location E35 (Ref 5:8). Device ROMs are matched to the device handler they support. As a result, changes in system disk drive units require that appropriate device ROMs (corresponding to the installed disk drive units) be installed on the M9312. The M9312 will accommodate ROMs for several devices.

The Fast-on Tabs (TP1, TP2, TP3 and TP4) located on the M9312 bootstrap module are not used by the PDP-11/15 computer. The Fast-on tabs are used by PDP-11/34 computers for boot-up procedures. Consequently, the Fast-on Tabs on the M9312 were not installed in the PDP-11/15 computer (Ref 5:10).

The procedures for booting the system disk (without diagnostic checks) were the same as those outlined under installation procedures for the software operating system. For diagnostic checks, the following procedures applied:

#### PROCEDURES

1. Power up all system components.
2. Load the XXDP.+ Diagnostics floppy disk into slot DY0 on the RX02 Disk Drive.
3. Load and start the PDP-11/15 computer at address 165020.
4. TTY will respond with four, six-digit numbers (indicating diagnostic checks of register contents), followed by an "@" prompt.

5. Type in "DY" and a carriage return.

6. The XXDP.+ monitor will automatically boot-up after the carriage return in step 5.

#### IV. TESTS AND ANALYSIS

##### HEATHKIT H-19A CRT TESTS

The Heathkit H-19A was interfaced to the PDP-11/15 via an RS-232C/Current-Loop Interface Unit. The TTY Controller Modules operate at 110 baud rate and 60 HZ cycle rate. The H-19A CRT performed all I/O operations successfully at 110 baud rates. Baud rates of 150, 300 and higher resulted in garbled character output on the CRT terminal. Any upgrade in baud rates would require modifications on TTY Controller Interface Modules.

##### DEC RT.11 BOOTSTRAP TESTS

The RX02 Disk Drive Unit was interfaced in an RX211 configuration (PDP-11 double density disk format). The RT.11 operating system would not boot in PDP-11/15 core memory via a hardware bootstrap (M9312 Bootstrap Module loaded at 173004) or a DEC RX02 software bootstrap instruction set for double density formatted disks.

The RX02 was reconfigured into an RX11 system (PDP-11 single density disk format). This configuration required an M7846 Interface Module to replace the M8256 Interface Module required for the RX211 configuration. The switch configurations on the M7744 Module in the RX02 were set to (S1-1 ON, S1-2 OFF) to conform to the new RX11 configuration. For single density operation, an RT.11 operating system formatted on a single density disk was utilized. The results

were the same as the RX211 configuration. The RT.11 operating system would not boot in the RX11 configuration via the M9312 Hardware Bootstrap Module (loaded at 173004) or the DEC software bootstrap instructions for single density operation.

The system was reconfigured again by installing an RX01 disk drive (with associated M7846 Interface Module). A single density formatted disk with RT 11 operating system was utilized as the software media. As with previous tests, the RX01 system would not boot the operating system into core memory via the DEC RX01 single density software bootstrap instructions. A hardware bootstrap module for the RX01 was not available for testing.

Foreground/Background (FB) and Single Job (SJ) RT.11 operating systems were tested in all three configurations with no positive results. Configurations utilizing the M9312 Hardware Bootstrap Module were started at address 165020. This address is the start address for activation of the bootstrap diagnostics ROM and subsequent activation of the device ROM on the Bootstrap Module. At start address 165020, the TTY printed four, six-digit numbers (indicating diagnostic checks of CPU registers, followed by an "@" prompt. The TTY was enabled after the "@" prompt was printed. The device mnemonics "DY", "DY0", or "DY1" were the only inputs accepted by the terminal. Correct bootstrap procedures require that the operator type in the device mnemonic (DY, DY0 or DY1) after the TTY prompt. The operating system should

immediately boot-up after the operator types in the device mnemonic and a carriage return. In the RX02 configurations tested, the TTY would immediately lock-up (after the RX02 disk heads reset to track zero) when DY, DY0 or DY1 were entered with a carriage return. The RX01 configuration (tested only on a software bootstrap) locked-up immediately when the bootstrap instructions were loaded and started. These tests indicated that the M9312 Bootstrap Diagnostics ROM was working properly (to include the device mnemonic prompt). Likewise, the RX02 disk head movement indicated that I/O instructions were accessing the disk. An inability to boot the RT.11 (version four) operating system to core memory prevented utilization of the RT.11 Peripheral Interchange Program (PIP) for transfers of paper tape files to disk files.

GENRAD (producers of the 1923/30 system) indicated that only an RT.11 (version two or older) operating system would be compatible with the ADC equipment in the system. Records indicated that in 1980 an AED 2500 Disk Drive Unit was utilized to bootstrap an RT.11SJ.V02C (RT.11 version two) floppy disk based operating system to the PDP-11/15 computer. DEC device handler files (for I/O devices) are written to be compatible with specific RT.11 operating system versions. Device handlers for the same hardware differ for various RT.11 versions. The AED 2500 device handler program was written to operate specifically with a version two RT.11 operating system. The floppy disk based operating system tested with

the RX02 Drive Unit was a version four RT.11 operating system. The RX02 Disk Drive was designed and built after the development of the RT.11 version two operating system. As a result, operation of an RT.11 version two operating system on the 1923/30 system would require the addition of a DY.SYS device handler program compatible with the RT.11 version two operating system. An RX02 device handler for RT.11SJ.V02C could be written by utilizing the AED 2500 version two device handler program and a current listing of the version four RT.11 device handler for the RX02 Disk Drive. A working RT.11 operating system (version two) could be produced by combining a currently available RT.11SJ.V02C operating system with the modified RX02 device handler.

#### DIAGNOSTIC TESTS

##### RX02 DISK DRIVE TESTS

The RX02 Disk Drive was configured in the RX211 mode for diagnostic testing. The RX02 Disk Drive properly bootstrapped the XXDP.+ Diagnostic double density formatted disk when the software media was loaded into disk slot DY0. This successful bootstrap operation verified I/O operations between the RX02 disk drive and the H-19A CRT. Likewise, successful diagnostic boot-up of the XXDP.+ monitor file verified hardware modifications/installations on the UNIBUS backplane structure.

A separate DEC diagnostics processor program was loaded and tested via the XXDP.+ monitor program. The PDP-

11/15 failed to successfully pass the processor diagnostics check. Additionally, UPD2 Peripheral-Interchange-Program (PIP) utility commands on the XXDP.+ monitor file were used to transfer paper tape diagnostic programs from the High-speed Paper Tape Reader to a floppy disk in the RX02 DY1 slot. The UPD2 PIP commands activated the High-speed Paper Tape Reader and test tapes were read by the unit. Subsequent load and start commands, via the XXDP.+ monitor file, failed to activate the diagnostic programs transferred from paper tape to disk. Likewise, XXDP.+ boot commands failed to boot a floppy disk based RT.11SJ.V04 operating system in the RX02 DY1 unit slot. The RX02 floppy disk test failures indicated possible hardware malfunctions in the CPU/Memory Unit and/or software incompatibility problems with the RT.11SJ.V04 disk based operating system.

Diagnostic tests for the system were run via the XXDP.+ monitor file floppy disk. The results from the test runs were as follows:

<u>FILENAME</u>	<u>RESULTS</u>
ZRXFA1.BIC	Line frequency clock test - routine ran with inconclusive results
DZKEDA.BIC	EAE test - EAE passed test
ZM9BC0.BIC	M9312 Boot Terminator test - routine ran with inconclusive results
ZQMCFO.BIC	Memory tests - routine did not run

## PAPER TAPE OPERATIONS

Paper tape operations on the 1923/30 system were performed by means of a bootstrap loader, absolute binary loader and system/diagnostic paper tapes.

Prior to loading/running any paper tapes, the 1923/30 system was powered-up. The Main 120V circuit breaker switch, PDP-11/15 power switch, DATARAM memory power switch and TTY/CRT power switch were turned on in that order. All paper tapes were loaded into the right feed bin of the High-speed Paper Tape unit and deposited into the left feed bin after the completion of read operations (see Figure 18). The High-speed Paper Tape Reader power switch was set to load before loading any tapes. Each paper tape was placed under the reader brake shoes, over the readhead assembly and between the forward capstan and forward pinch roller. Upon completion of tape loading, the tape guide was pulled down over each loaded tape (see Ref 18:5-2).

### LOADING BOOTSTRAP LOADER

After successful system power-up, the following bootstrap loader instructions were loaded into core memory via the PDP-11/15 front console control switches:

<u>ADDRESS LOCATION</u>	<u>INSTRUCTION</u>
157744	016701
157746	000026
157750	012702
157752	000352
157754	005211
157756	105711
157760	100376

AU-A138 111 UPGRADE VERIFICATION AND DOCUMENTATION OF GENERAL MAUIU 2/2  
1923 TIME SERIES SYSTEM(U) AIR FORCE INST OF TECH  
WRIGHT-PATTERSON AFB OH SCHOOL OF ENGI... B A CASELLA  
UNCLASSIFIED DEC 83 AFIT/GE/EE/B3D-15 F/G 9/2 NL



END  
DATE  
FILMED  
3-84  
DTIC

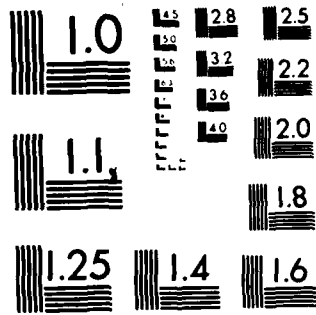

MICROCOPY RESOLUTION TEST CHART  
NATIONAL BUREAU OF STANDARDS 1963-A

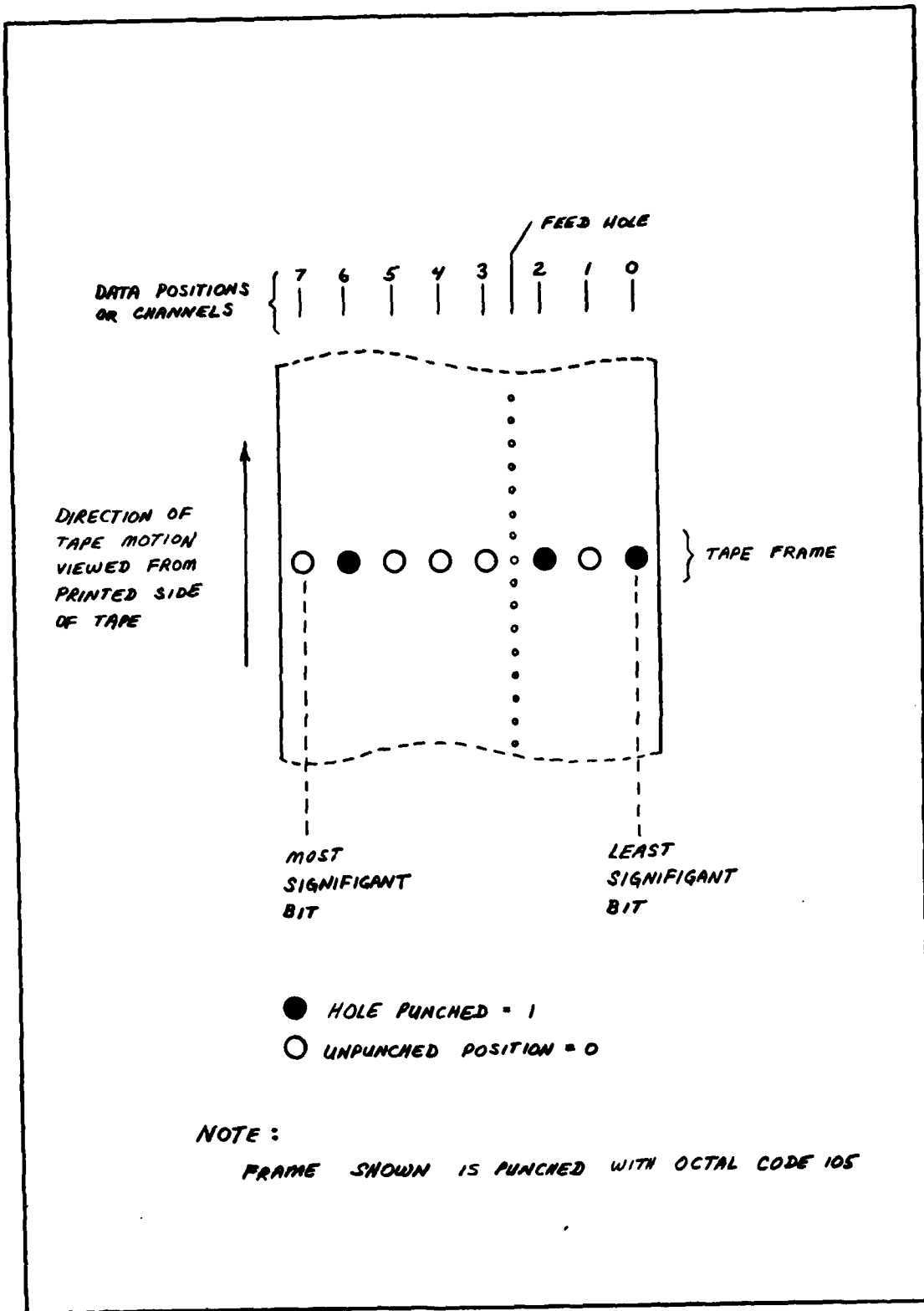

Figure 18. PAPER-TAPE FORMAT

157762	116162
157764	000002
157766	157400
157770	005267
157772	177756
157774	000765
157776	177550

The bootstrap loader instructions in core memory were verified and the computer console switch was placed in the HALT position.

#### LOADING ABSOLUTE BINARY LOADER

The Absolute Binary Loader is in bootstrap format. The bootstrap loader tapes are punched in bootstrap format. As a result, the Absolute Binary Loader was loaded into core memory as follows:

1. The PDP-11/15 ENABLE/HALT switch was set to HALT.
2. The Absolute Binary Loader tape was loaded into the High-speed Paper Tape Reader ensuring that the 351 octal code on the tape was positioned (see Figure 18) directly over the readhead assembly on the reader.
3. The reader power switch was set to RUN.
4. The bootstrap loader start address (157744) was set on the PDP-11/15 switch register.
5. The PDP-11/15 ENABLE/HALT switch was set to ENABLE.
6. The PDP-11/15 START switch was pushed down.

7. The PDP-11/15 ENABLE/HALT switch was set to HALT when the tape reading was complete.

#### LOADING SYSTEM/DIAGNOSTIC TAPES

The system/diagnostic tapes are punched in absolute binary format. As a result, the system/diagnostic tapes were loaded into core memory after the absolute binary loader was loaded into memory via the bootstrap loader. The system/diagnostic tapes were loaded as follows:

1. The system/diagnostic tapes were loaded into the High-speed Paper Tape Reader with only feedholes over the readhead assembly.

2. The reader power switch was set to RUN.

3. The octal address 157500 was set on the switch registers.

4. The PDP-11/15 START switch was pushed down.

5. The PDP-11/15 ENABLE/HALT switch was set to HALT when tape reading was complete.

6. Individual tapes read into core memory were activated by starting them at their respective start addresses. The TSL System Program requires that the instruction (070707) be placed into switch register 000344 before the TSL system tape is read into core memory.

#### PAPER TAPE TESTS

Paper tape diagnostic tests for the system were

run via the High-speed Paper Tape Reader. The results from the test runs were as follows:

<u>PAPER TAPE NAME</u>	<u>RESULTS</u>
General Test Program	Program completed five tests (RANDAT, Worst Case Noise, Moving ones and zeros, Memory disturbance, Basic memory patterns); rest of program did not run; inconclusive results
Basic Memory Patterns Test	Program did not run
Memory Moving One's and Zero's	Errors detected at address 160000
No Dual Address Test	Errors detected at numerous addresses
11 Family Instruction Exerciser	Program did not run
T17-4K System Exerciser	Program did not run
Communications Test Program	Program did not run
Maintenance 1923	All ADC equipment lights were checked out

Diagnostic tests on the floppy disk unit and the paper tape unit were inconclusive. Important memory checkout packages (floppy and paper tape based) failed to run on the 1923/30 system. As a result, the system CPU/Memory Unit should be isolated and checked for malfunctions. All CPU processor modules, with the exception of the KC11 front console module, were checked for proper operation. Direct substitution of each module with known good modules produced no positive results.

## V. CONCLUSIONS AND RECOMMENDATIONS

### CONCLUSIONS

The 1923/30 Time-Series System was upgraded by interfacing an RX02 Disk Drive and a Heathkit H-19A CRT to the PDP-11/15 system computer. The RX02 Disk Drive was successfully interfaced to the PDP-11/15 computer by means of a modified DD11-A Module, M8256 Interface Controller Module, KF11-A Multiple Bus Priority Module and a KW11-L Line Time Clock Module. The Heathkit H-19A CRT was successfully interfaced to the PDP-11/15 computer by means of an RS-232C/Current-Loop Interface Unit. The DEC XXDP.+ Diagnostics disk media was successfully bootstrapped via the RX02 Disk Drive Unit. The RX02 Disk Drive failed to bootstrap the DEC RT.11 operating system into core memory. As a result, existing paper tape programs were not transferred to disk media via the RT.11 operating system.

### RECOMMENDATIONS

The following recommendations are proposed for further study:

1. The PDP-11/15 processor should be thoroughly checked for processor malfunctions and memory problems.
2. Upon successful operation of the PDP-11/15 processor/memory diagnostic routines, the DEC RT.11 operating system should be bootstrapped into core memory via the RX02 Disk Drive configuration. The RT.11 bootstrap operation would

require utilization of available RT.11 (version two) operating system. An RX02 device handler program should be written to make the RT.11 (version two) operating system compatible to the system configuration.

3. The RT.11 operating system utility programs should be used to transfer existing paper tape programs to eight inch floppy disks. Upon successful completion of file transfers, the TSL 30/PANEL 30 operating systems, with associated overlay programs, should be bootstrapped into core memory and checked for proper operation.

4. A user's manual for disk/paper tape operations should be written.

5. Procurement of state-of-the-art (SOA) GENRAD 2505 Time-Series Analysis System should be investigated. The ADC equipment in the 1923/30 System (produced by GENRAD) is no longer supported by GENRAD for parts or repair work. The new 2505 GENRAD system offers increased efficiency/capabilities and full hardware/software support. The 2505 Signal Analysis Minisystem is the current Signal Analysis System produced by GENRAD. The 2505 system consists of the following:

1. Two Channel Analog-to-Digital Inputs (ADS)
2. PDP-11/04 Controller
3. 32K Core Memory
4. Dual 5-1/4 inch floppy disk media
5. Keyboard/Display/Pedestal

6. 2501 Microprocessor
7. Firmware ZOOM
8. RT.11 Operation System
9. TSL/TSLAP
10. ISAP consisting of the following functions:
  - a. Sampled time data
  - b. Instantaneous input spectrum
  - c. Auto-and cross-spectrum
  - d. Auto-and cross-correlation
  - e. Amplitude probability density
  - f. Waveform averaging
  - g. Transfer function, impulse response,  
and coherence functions

## Bibliography

1. Dataram Corporation. Core Memory System DR-103. System brochure. Cranbury, New Jersey: Dataram Corporation, 1975.
2. Digital Equipment Corporation. Floating-Point Math Package (FPMP-11) User's Manual. Maynard, Massachusetts: Digital Equipment Corporation, 1972.
3. Digital Equipment Corporation. KC11 Processor Engineering Drawings. PDP-11 processor module schematics. Maynard, Massachusetts: Digital Equipment Corporation, 1971.
4. Digital Equipment Corporation. KC11 Processor Manual. Maynard, Massachusetts: Digital Equipment Corporation, 1971.
5. Digital Equipment Corporation. M9312 Field Maintenance Print Set. M9312 Bootstrap Terminal technical drawings. Maynard, Massachusetts: Digital Equipment Corporation, 1978.
6. Digital Equipment Corporation. PDP-11 Introduction to RT.11. PDP-11 operating system manual. Maynard, Massachusetts: Digital Equipment Corporation, 1977.
7. Digital Equipment Corporation. PDP-11 KE11-A Extended Arithmetic Element. Operations manual. Maynard, Massachusetts: Digital Equipment Corporation, 1971.
8. Digital Equipment Corporation. PDP-11/15/20/r20 Processor Handbook. Maynard, Massachusetts: Digital Equipment Corporation, 1971.
9. Digital Equipment Corporation. PDP-11 Peripherals and Interfacing Handbook. Maynard, Massachusetts: Digital Equipment Corporation, 1971.
10. Digital Equipment Corporation. PDP-11/15 Peripheral Handbook. Maynard, Massachusetts: Digital Equipment Corporation, 1978.
11. Digital Equipment Corporation. PDP-11 Paper Tape Software Programming Handbook. Maynard, Massachusetts: Digital Equipment Corporation, 1970.
12. Digital Equipment Corporation. PDP-11/15 System Manual. Maynard, Massachusetts: Digital Equipment Corporation, 1971.

13. Digital Equipment Corporation. RX02 User's Guide. Operation, service and programming manual for RX02 disk unit. Maynard, Massachusetts: Digital Equipment Corporation, 1978.
14. Digital Equipment Corporation. RX211 Field Maintenance Print Set. RX211 Floppy Disk schematic drawings. Maynard, Massachusetts: Digital Equipment Corporation, 1978.
15. General Radio Company. "Signal Analysis with Digital Time-Series Analyzers," The General Radio Experimenter, 44: 3-7 (July 1970).
16. Heath Company. Heathkit Manual for the Video Terminal Model H-19A. Operations manual. Benton Harbor, Michigan: Heath Company, 1981.
17. Hewlett-Packard Company. X-Y Recorder 703A. Operating and service manual. San Diego, California: Hewlett-Packard Company, 1971.
18. Iomec Inc. Digitronics Division. Model 2540 Perforated Tape Reader Operation and Maintenance Manual. Southboro, Massachusetts: Digitronics Division Publication Department, 1972.
19. Muchow, Kenneth. Microprocessors, Principles, Programming and Interfacing. Reston, Virginia: Reston Publishing Company, Inc., 1983
20. Sudduth, Robert C. Evaluation of the Time/Data 1923/30 System. Unpublished EE6.87 laboratory report. Wright-Patterson AFB, Ohio: School of Engineering, Air Force Institute of Technology, March 1980.
21. Tektronix, Inc. Instruction Manual 603/604 Monitor. Operating and service manual. Beaverton, Oregon: Tektronix, Inc., 1971.
22. Texas Instruments, Inc. The TTL Data Book. Dallas, Texas: Texas Instruments, Inc., 1981.
23. Time/Data Corporation. Modal Analysis Package for TSL. Software operating notes. Palo Alto, California: Time/Data Corporation, 1973.
24. Time/Data Corporation. Operating Manual, Time-Series System 1923/30. Palo Alto, California: Time/Data Corporation, 1973.

25. Time/Data Corporation. Programming Manual, Time-Series Language (TSL). Palo Alto, California: Time/Data Corporation, 1974.
26. Time/Data Corporation. 1923 "Superpanel" System Programs PANEL-30, PANEL-50. Software operating notes. Palo Alto, California: Time/Data Corporation, 1973.
27. Time/Data Corporation. 1923-5002A TSL Reference Handbook. Programming reference manual. Palo Alto, California: Time/Data Corporation, 1974.

### VITA

Bruce Anthony Casella was born on 1 February 1953 in Vallejo, California. He graduated as salutatorian of Colfax High School in Colfax, California in 1971. Upon high school graduation he accepted an appointment to the United States Military Academy at West Point, New York. He graduated from West Point in 1975 with a Bachelor of Science degree and commission as a second lieutenant in the United States Army. After attending the Army Signal Officers Basic Course in 1975, he served as a signal communications officer in South Korea, Fort Polk, Louisiana, and the Federal Republic of Germany. He received the degree of Master of Science in Systems Management from the University of Southern California in Los Angeles, California in 1981. Upon completing the Army Signal Officers Advanced Course and Computer Systems Teleprocessing Program at the Air Force Institute of Technology in 1982, he entered graduate study in the School of Engineering at the Air Force Institute of Technology.

Permanent address: 2948 Pasatiempo Place  
Sacramento, California 95833

REPORT DOCUMENTATION PAGE		READ INSTRUCTIONS BEFORE COMPLETING FORM
1 REPORT NUMBER AFIT/GE/EE/83D-15	2 GOVT ACCESSION NO.	3 REPORT NUMBER REPORT'S CATALOG NUMBER
4 TITLE (and Subtitle) UPGRADE, VERIFICATION, AND DOCUMENTATION OF GENERAL RADIO 1923 TIME SERIES SYSTEM		5 TYPE OF REPORT & PERIOD COVERED MS Thesis
7 AUTHOR(s) Bruce A. Casella CPT		6 PERFORMING ORG REPORT NUMBER
9 PERFORMING ORGANIZATION NAME AND ADDRESS Air Force Institute of Technology (AFIT-EN) Wright-Patterson AFB, Ohio, 45433		8 CONTROLLING OFFICE REPORT NUMBER
11 CONTROLLING OFFICE NAME AND ADDRESS		10 PROGRAM ELEMENT PROJECT TASK AND WORK UNIT NUMBERS
14 MONITORING AGENCY NAME & ADDRESS (if different from Controlling Office)		12 REPORT DATE December 1983
		13 NUMBER OF PAGES 103
		15 SECURITY CLASS (of this report) Unclassified
		15a SECURITY CLASSIFICATION DOWNGRADING SCHEDULE
16 DISTRIBUTION STATEMENT (of this Report)  Approved for public release; distribution unlimited		
17 DISTRIBUTION STATEMENT (of the abstract entered in Block 20, if different from Report)		
18 SUPPLEMENTARY NOTES  <div style="text-align: right;"> <i>Lyn Wolan</i> 7 Feb 84            Lynn E. Wolan, Development            Dec 1983            Air Force Institute of Technology (AFIT)            Wright-Patterson AFB, Ohio 45433         </div>		
19 KEY WORDS (Continue on reverse side if necessary and identify by block number)  Disk Drive Interface PDP-11/15 Computer Time-Series Analysis System		
20 ABSTRACT (Continue on reverse side if necessary and identify by block number)  This paper documents the procedures for upgrading a General Radio Time-Series Analysis 1923/30 System. The upgrading procedures included installation of a Heathkit H-19 CRT and interface of a DEC RX02 Disk Drive to the PDP-11/15 system computer. The RX02 Disk Drive interface required the installation of a KF11-A Multiple Bus Priority Module, KW11-L Line Time Clock Module, M8256 Controller Module, M9213 Bootstrap Module, software operating system, and the modification of the DD11-A Backplane Module. Various hardware disk drive configurations and software operating systems were tested.		