

AD-A138 148

MICROWAVE-ENHANCED IGNITION IN DIESEL ENGINES(U) BDM
CORP HOUSTON TX R M BASS ET AL. 15 DEC 83 BDN-12780
DRAE07-83-A-R040

1/1

UNCLASSIFIED

F/G 21/2

NL

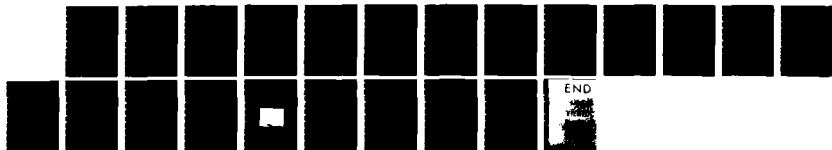

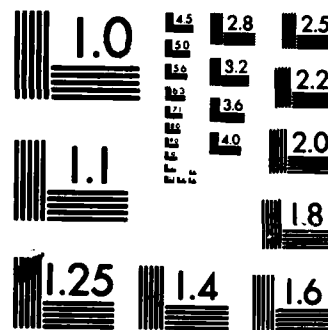

MICROCOPY RESOLUTION TEST CHART
NATIONAL BUREAU OF STANDARDS-1963-A

THE BDM CORPORATION

12

Report Number 12780

ADA138148

Microwave-Enhanced Ignition in Diesel Engines

Dr. Ronald M. Bass
Alan C. Chachich
The BDM Corporation
3100 South Gessner, Suite 303
Houston, Texas 77063

15 December 1983

Final Report for Period 13 July 1983 - 30 December 1983

DTIC
FEB 17 1984
A

DTIC FILE COPY

Prepared for
U.S. Army Tank Command
ATTN: DRSTA-IRRR
Warren, MI 48090

Approved for Public Release;
Distribution Unlimited

84 02 16 065

SECURITY CLASSIFICATION OF THIS PAGE (When Data Entered)

REPORT DOCUMENTATION PAGE		READ INSTRUCTIONS BEFORE COMPLETING FORM
1. REPORT NUMBER Report No. 12780	2. GOVT ACCESSION NO. AD-A138 148	3. RECIPIENT'S CATALOG NUMBER
4. TITLE (and Subtitle) Microwave-Enhanced Ignition in Diesel Engines		5. TYPE OF REPORT & PERIOD COVERED Final 13 Jul. 83 to 30 Dec. 83
		6. PERFORMING ORG. REPORT NUMBER
7. AUTHOR(s) Dr. Ronald M. Bass Alan C. Chachich		8. CONTRACT OR GRANT NUMBER(s) DAAE07-83-M-R040
9. PERFORMING ORGANIZATION NAME AND ADDRESS The BDM Corporation 3100 South Gessner, Ste. 303 Houston, Texas 77063		10. PROGRAM ELEMENT, PROJECT, TASK AREA & WORK UNIT NUMBERS
11. CONTROLLING OFFICE NAME AND ADDRESS U.S. Army Tank Command ATTN: DRSTA-IRRR		12. REPORT DATE 15 Dec. 83
		13. NUMBER OF PAGES
14. MONITORING AGENCY NAME & ADDRESS (if different from Controlling Office)		15. SECURITY CLASS. (of this report) Unclassified
		15a. DECLASSIFICATION/DOWNGRADING SCHEDULE
16. DISTRIBUTION STATEMENT (of this Report) Approved for public release; distribution unlimited		
17. DISTRIBUTION STATEMENT (of the abstract entered in Block 20, if different from Report)		
18. SUPPLEMENTARY NOTES		
19. KEY WORDS (Continue on reverse side if necessary and identify by block number) Microwave Diesel Ignition Combustion		
20. ABSTRACT (Continue on reverse side if necessary and identify by block number) <u>PURPOSE OF THE PROJECT</u> An effective method for microwave enhancement of ignition in diesel engines may result in significant benefits, as follows: (1) permit the use of lean fuel-air mixtures, thereby im- proving fuel efficiency (Continued - see attachment)		

20. ABSTRACT (Continued)

- (2) permit the use of a wide variety of fuels
- (3) provide control over the firing angle and the combustion rate, thereby allowing more uniform delivery of power to the crankshaft and permitting lower compression ratios.

BDM has proposed concepts for microwave-enhanced ignition and for conducting quantitative experiments to evaluate microwave-enhanced ignition and combustion. The purpose of this project was to demonstrate these concepts in laboratory tests.



A-1

SUMMARY

A. PURPOSE OF THE PROJECT

An effective method for microwave enhancement of ignition in diesel engines may result in significant benefits, as follows:

- (1) permit the use of lean fuel-air mixtures, thereby improving fuel efficiency
- (2) permit the use of a wide variety of fuels
- (3) provide control over the firing angle and the combustion rate, thereby allowing more uniform delivery of power to the crankshaft and permitting lower compression ratios.

BDM has proposed concepts for microwave-enhanced ignition and for conducting quantitative experiments to evaluate microwave-enhanced ignition and combustion. The purpose of this project was to demonstrate these concepts in laboratory tests.

B. SUMMARY OF APPROACH

The ignition technique consists of inserting a horseshoe-shaped wire (igniter) with sharpened ends into a microwave field. When the field is sufficiently intense, an arc forms across the tips, effectively acting as a spark plug.

Tests were conducted in a special instrumented waveguide section that could be irradiated with up to 2500 watts of microwave power. The igniter was tested by inserting it into the waveguide test section and increasing the microwave power until an arc was observed.

Combustion tests were conducted by inserting the igniter and a small amount of fuel into a quartz tube. The tube was sealed, inserted into the waveguide, and preheated to vaporize the fuel. Microwave power was applied to induce an arc in the igniter. The tube was then removed from the waveguide and cooled, and the condensates were examined to verify that combustion occurred.

C. SUMMARY OF RESULTS AND FINDINGS

1. Igniter Design Tests

An igniter design was developed that consistently produced arcing in air with as little as 70 watts of microwave power. Tungsten wire was the most effective of several materials that were tested.

2. Ignition Tests

Partial or complete combustion was achieved in all four ignition tests in which the fuel was preheated, with air/fuel ratios from 12.35 to 13.73. Preheating to vaporize the fuel was required to achieve combustion.

3. Experiment Procedure

An inexpensive and effective procedure was established for testing the effects of microwave-enhanced ignition and combustion. Quantitative analysis of the combustion products could be readily obtained by analyzing the product gases with gas chromatography.

D. RECOMMENDATIONS

1. Additional Laboratory Ignition and Combustion Tests

Additional laboratory tests should be conducted to improve understanding of igniter performance and to further evaluate combustion effects. Bench scale atmospheric-pressure laboratory tests are essential to help interpret and design engine tests.

Additional tests should be conducted to clarify the effects of materials and geometry on igniter performance, and operating life. These tests would provide a basis for designing igniters for engine tests.

Additional tests should also be conducted to quantify and further evaluate the effects of the microwave field on ignition. Quantification can be achieved by analyzing combustion products with gas chromatography. The effects of microwaves can be further evaluated by conducting trials with variations in power level, by testing a wider range of air fuel ratios, and by varying the sample orientation in the waveguide. Because a test methodology has been established, a large number of trials can now readily be conducted to provide a broad statistical basis for interpreting test results.

THE BDM CORPORATION

2. Engine tests

A program of engine tests should be initiated. The effectiveness of microwave-enhanced ignition and combustion methods can be most quickly evaluated and improved by working in a realistic engine operating environment. The goals of an initial engine test project should be:

- (1) Develop and demonstrate methods for coupling microwave power into diesel engine cylinders
- (2) Develop and demonstrate quantitative methods for evaluating experiments on diesel engines
- (3) Obtain initial evaluations of the effect of microwave-enhanced ignition and combustion.

THE BDM CORPORATION

PREFACE

This work was performed for the U.S. Army Tank-Automotive Command, DRSTA-IRRR, Warren, Michigan, 48090 under contract number DAAE07-83-M-R040. The contract officer's technical representative was Mr. Al Lemmo. The investigators were Dr. Bernard Eastlund, Alan Chachich, and Dr. Ronald Bass of the BDM Corporation.

BDM gratefully acknowledges the use of laboratory facilities of Exxon Research and Engineering, Baytown, Texas, and the technical assistance of Dr. Gary McAllister of Exxon and Mr. Jack Crawford.

TABLE OF CONTENTS

<u>Chapter</u>		<u>Page</u>
	SUMMARY	i
	PREFACE	iv
	TABLE OF CONTENTS	v
	LIST OF FIGURES	vi
I.	INTRODUCTION	1
	A. Purpose of the Project	1
	B. Summary of Approach	1
	C. Summary of Results and Findings	2
	1. Igniter Design Tests	2
	2. Ignition Tests	2
	3. Experiment Procedure	2
	D. Recommendations	2
	1. Additional Laboratory Ignition and Combustion Tests	2
	2. Engine Tests	3
II.	Overview of the Experiment Concept and Apparatus	4
III.	IGNITER OPTIMIZATION	7
IV.	Air-fuel Mixture Ignition Experiments	9
	A. Overview of the Experiments	9
	B. Ignition Experiment Procedure	9
	C. Results of Ignition Experiments	11

LIST OF FIGURES

<u>Figure</u>		<u>Page</u>
1.	Experiment Apparatus	5
2.	Major Components of the Experiment Apparatus	6
3a.	Igniter Design Requiring Least Power (70 watts) for Break Down	8
3b.	Example of Photodetector Response to Igniter Arc	8
4.	Procedure for Ignition Experiments	10
5.	Results of Valid Ignition Experiments with Preheating to 370°	12

THE BDM CORPORATION

I. INTRODUCTION

A. PURPOSE OF THE PROJECT

An effective method for microwave enhancement of ignition and combustion in diesel engines may result in significant benefits, as follows:

- (1) permit the use of lean fuel-air mixtures, thereby improving fuel efficiency
- (2) permit the use of a wide variety of fuels
- (3) provide control over the firing angle and the combustion rate, thereby allowing more uniform delivery of power to the crankshaft and permitting lower compression ratios.

BDM has proposed a concept for microwave-enhanced ignition and for conducting quantitative experiments to evaluate microwave-enhanced ignition and combustion. The purpose of this project was to demonstrate these concepts in laboratory tests.

B. SUMMARY OF APPROACH

The ignition technique consists of inserting a horseshoe-shaped wire (igniter) with sharpened ends into a microwave field. When the field is sufficiently intense, an arc forms across the tips, effectively acting as a spark plug.

Tests were conducted in a special instrumented waveguide section that could be irradiated with up to 2500 watts of microwave power. The igniter was tested by inserting it into the waveguide test section and slowly increasing the microwave power until an arc was observed.

Combustion tests were conducted by inserting the igniter and a small amount of fuel into a quartz tube. The tube was sealed, inserted into the waveguide, and preheated to vaporize the fuel. Microwave power was applied to induce an arc in the igniter. The tube was then removed from the waveguide and cooled, and the condensates were examined to verify that combustion occurred.

THE BDM CORPORATION

C. SUMMARY OF RESULTS AND FINDINGS

1. Igniter Design Tests

An igniter design was developed that consistently produced arcing in air with as little as 70 watts of microwave power. Tungsten wire was the most effective of several materials that were tested.

2. Ignition Tests

Partial or complete combustion was achieved in all four tests in which the fuel was preheated, with air/fuel ratios from 12.35 to 13.73. Preheating to vaporize the fuel was required to achieve combustion.

3. Experiment Procedure

An inexpensive and effective procedure was established for testing the effects of microwave-enhanced ignition and combustion. Quantitative analysis of the combustion products could be readily obtained by analyzing the product gases with gas chromatography.

D. RECOMMENDATIONS

1. Additional Laboratory Ignition and Combustion Tests

Additional laboratory tests should be conducted to improve understanding of igniter performance and to further evaluate combustion effects. Bench scale atmospheric-pressure laboratory tests are essential to help interpret and design engine tests.

Additional tests should be conducted to clarify the effects of material and geometry on igniter performance and operating life. These tests would provide a basis for designing igniters for engine tests.

Additional tests should also be conducted to quantify and further evaluate the effects of the microwave field on ignition. Quantification can be achieved by analyzing combustion products with gas chromatography. The effects of microwaves can be further evaluated by conducting trials with variations in power level, by testing a wider range of air fuel ratios, and by varying the sample orientation in the waveguide. Because a test methodology has been established, a large number of trials can now be readily conducted to provide a broad statistical basis for interpreting test results.

THE BDM CORPORATION

2. Engine Tests

A program of engine tests should be initiated. The effectiveness of microwave-enhanced ignition and combustion methods can be most quickly evaluated and improved by working in a realistic engine operating environment.

The goals of an initial engine test project should be:

- (1) Develop and demonstrate methods for coupling microwave power into diesel engine cylinders
- (2) Develop and demonstrate quantitative methods for evaluating experiments on diesel engines
- (3) Obtain initial evaluations of the effect of microwave-enhanced ignition and combustion.

II. OVERVIEW OF THE EXPERIMENT CONCEPT AND APPARATUS

The purpose of the experiments was to cause ignition of diesel fuel with microwave-induced breakdown. The experiment configuration is shown in Figures 1 and 2. Fuel samples were inserted into a quartz ignition chamber, which was placed into a special waveguide section on top of a ceramic holder (not shown). A horseshoe-shaped tungsten wire (igniter) was also placed inside the ignition chamber. When microwave power is applied, an arc forms across the tips of the horseshoe, igniting the fuel. Means were provided to preheat the waveguide (not shown) to vaporize the fuel prior to ignition. A temperature probe (not shown) was provided to measure the waveguide temperature. A fiber optic photodetector (not shown) was inserted in the waveguide to monitor light emitted by igniter arcing and fuel combustion. A screen was included in the waveguide test section to permit visual observation of the experiments. A stub tuner and forward and reflected power meters were used to adjust and monitor the microwave power delivered to the ignition chamber. Contrary to our original plan, a pressure transducer was not included. The intended purpose of the pressure measurement was to verify combustion. As described in Chapter IV, this function was instead accomplished by examining combustion product condensates. Introduction of a pressure transducer into the ignition chamber would have distorted the microwave field and thereby complicated the evaluation of power levels applied to the sample.

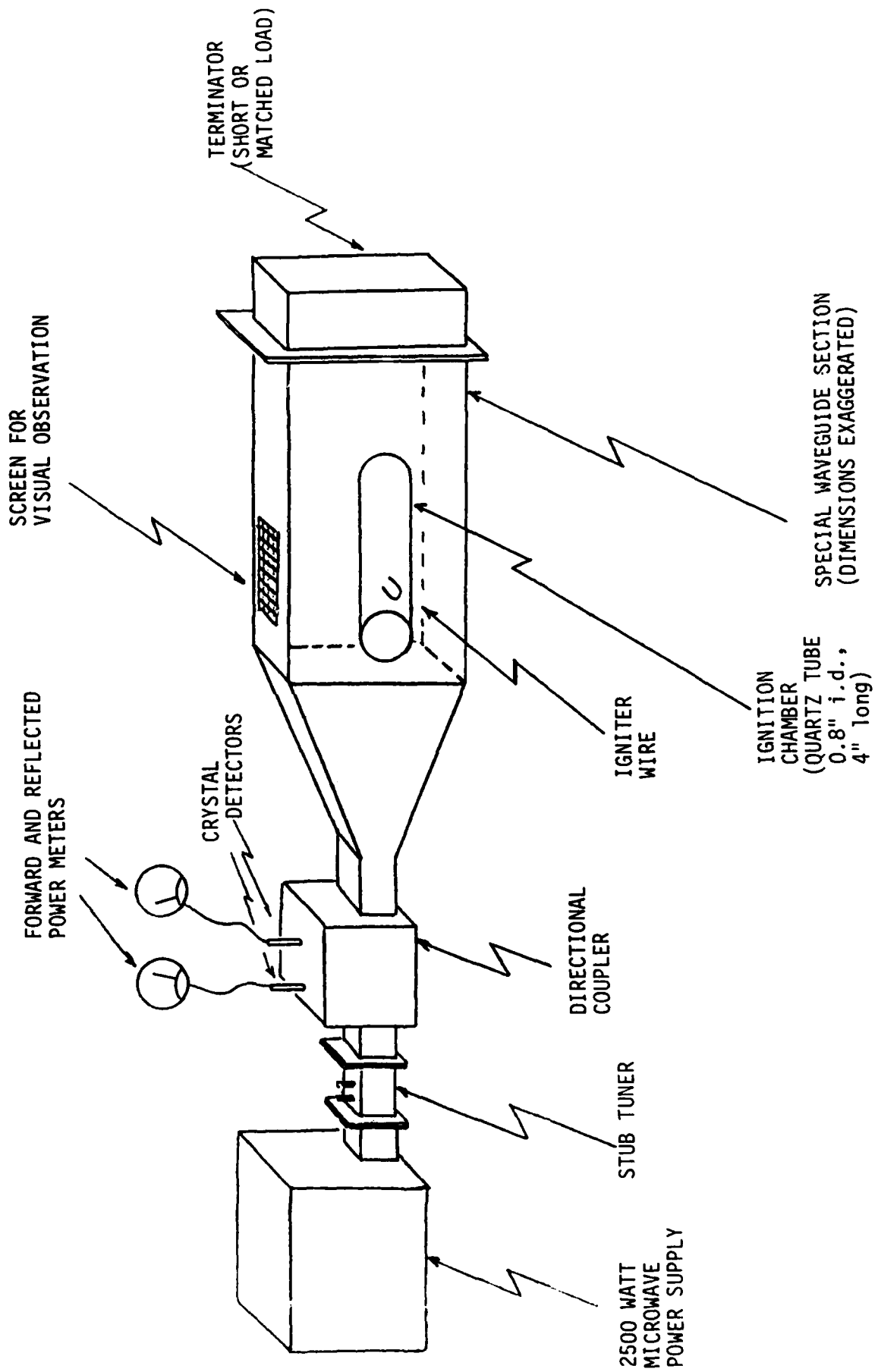

Figure 1. Experiment Apparatus

THE BDM CORPORATION

- o 2500 watt microwave power supply and S band waveguide.
- o Matched load termination.
- o Reflecting plate termination.
- o Waveguide test section (with wire mesh side for observation and ports for diagnostic probes).
- o Electrical heating system
 - 1300°F electric heating strip
 - Cerafoam insulation (one inch thick sheets).
 - Variac variable power supply.
- o Tungsten igniters.
- o Quartz ignition chambers.
- o Ceramic holder for ignition chambers.
- o Luxtron fiber optic temperature probe.
- o Photodetection system
 - Phototransistors
 - Fiber optic light pipe
 - Lucite mounting blocks
 - Amplifier circuit
 - Digital storage oscilloscope

Figure 2. Major Components of the Experiment Apparatus

III. IGNITER OPTIMIZATION

Prior to the fuel ignition experiments, over one hundred tests were conducted to optimize the igniter for the ignition experiments. The parameters varied included: igniter material, size, geometry, orientation, and placement in the microwave field. Also tested were different microwave field configurations to maximize igniter efficiency. The tests were conducted by placing the igniter in the waveguide test section and observing the minimum power required to form an arc. A profile of the igniter arc light intensity versus time was obtained with the fiber optic photodetection system, as illustrated in Figure 3b. The materials tested were copper, nickel, and tungsten. Geometries tested included loops, rectangles, horseshoes, and bent horseshoes.

Tests were conducted both with traveling waves (matched load waveguide termination) and standing waves (shorted waveguide termination). The major conclusions from the igniter design tests are as follows:

- (1) The igniter arced in air at microwave power levels as low as 70 watts.
- (2) Much less power was required for the igniter to arc when correctly located at a standing wave field maximum (breakdown at 70-400 watts) than in a traveling wave field (breakdown at 800-1600 watts).
- (3) Igniter performance was strongly influenced by the surface characteristics and material of the igniter tips. Tungsten wire was far more effective than copper or nickel wire. Sharp tips on the wire improved igniter effectiveness. The tip surfaces degraded with use, necessitating periodic recutting to achieve arcing.
- (4) The most effective shape tested was a "bent horseshoe", illustrated in Figure 3a. This design was used for the ignition tests described in the following section.

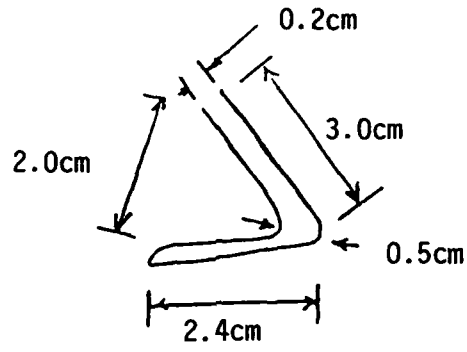

Figure 3a. Igniter design requiring least power (70 watts) for breakdown.

LIGHT
INTENSITY
(ARBITRARY
UNITS)

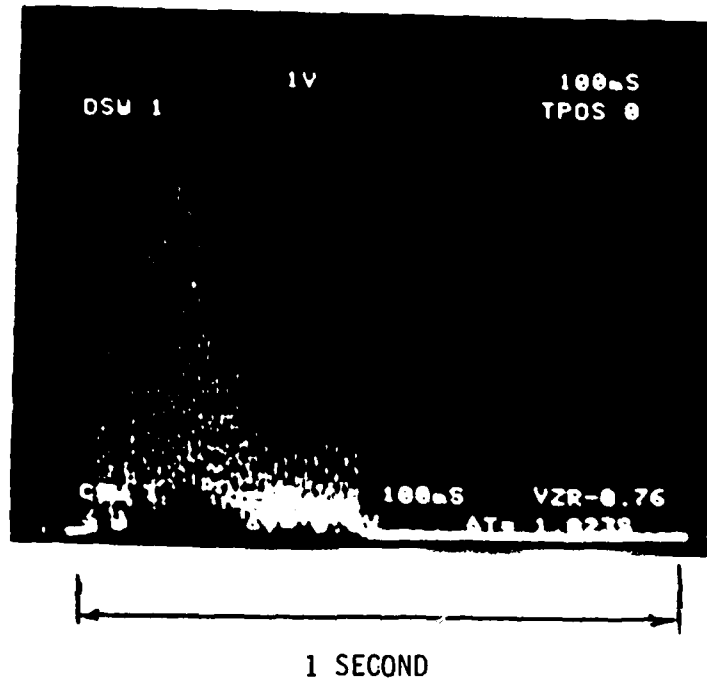

Figure 3b. Example of photodetector response to igniter arc.

IV. AIR-FUEL MIXTURE IGNITION EXPERIMENTS

A. Overview of the Experiments

Ignition experiments were conducted to demonstrate microwave-enhanced ignition and combustion for a range of air-fuel mixtures. Air-fuel mixtures ranged from 24.7:1 to 11.95:1. Number 2 diesel fuel was used in the experiments. Ignition was indicated by visual observation. Combustion was verified by examination of condensed byproducts. Details of the experiment procedure are described in Section B and results in Section C.

B. IGNITION EXPERIMENT PROCEDURE

The procedure is summarized in Figure 4. The preliminary tasks for each experiment included heating the waveguide (to $370 \pm 30^{\circ}\text{F}$), cleaning the ignition chamber, and trimming or filing the tips of the igniter. After this the igniter was inserted into the ignition chamber which was then flushed with "dry" (chemically filtered) air and sealed. Fuel was measured into a 5 microliter syringe and inserted into the ignition chamber. Following this the loaded ignition chamber was placed on a ceramic stand. The stand was carefully positioned in the waveguide to locate the igniter at a standing wave maximum. After attaching the waveguide termination, the waveguide test section was heated for 20 to 30 minutes.

Just prior to the application of microwave power, the thermal insulation was removed from the wire mesh portion of the waveguide test section. This permitted visual observation of the experiment. All ambient light sources were turned off or blocked. Microwave power was turned on and slowly increased until an arc occurred.

At the conclusion of an experiment, the microwave power was turned off and the ignition chamber was removed from the waveguide and visually inspected. The occurrence of combustion was determined by the observation of condensation in the ignition chamber. Water condensation was taken as evidence of combustion if no fuel condensation was present. One end of the chamber was immersed in cold water to cause the condensate to collect in a small area. Water was readily distinguished from fuel by the color, shape, and size of the droplets. The appearance and amount of both water and fuel condensates was compared to the

THE BDM CORPORATION

PREPARATION PHASE

1. Clean ignition chamber.
2. File tips of igniter.
3. Insert igniter into ignition chamber.
4. Flush ignition chamber with air to remove any moisture.
5. Measure fuel into 5 microliter syringes.
6. Insert fuel into ignition chamber.
7. Place ignition chamber on ceramic stand in the waveguide.
8. Attach waveguide termination.
9. Preheat waveguide for 20-30 minutes to assure fuel vaporization.
10. Remove thermal insulation from wire mesh portion of waveguide to permit visual observation of ignition.

IGNITION PHASE

11. Apply microwave power, increasing power level slowly until ignition occurs.
12. Turn off microwave power.

ANALYSIS PHASE

13. Remove the ignition chamber from the waveguide.
14. Inspect the ignition chamber for evidence of water and fuel condensation.
15. Estimate quantity of condensate.
16. Measure ph of condensate.

Figure 4. Procedure for Ignition Experiments

pre-experiment condition and a control chamber. The control chamber was fueled and heated only. The comparisons were carried out both when the chamber was hot and after it had cooled to room temperature. Condensate quantities were estimated with the aid of a scaled microscope. Finally the seals of the ignition chamber were breached and the ph of the condensate was measured.

C. RESULTS OF IGNITION EXPERIMENTS

After testing and debugging of the experiment apparatus, a series of seven complete ignition/combustion experiments were conducted with variations in air/fuel ratios, the temperature to which fuel was preheated and type of ignition chamber seals. Air/fuel ratios varied from 24.7:1 to 11.95:1. A high volatility fuel was used for these tests (No. 2 Diesel). Three of these, preheated to 150°F were unsuccessful. It was found necessary to preheat the fuel to 370°F to achieve ignition.

Four tests were conducted with the fuel preheated to 370°F. These tests are summarized in Figure 5. Combustion was achieved in three of the tests. Results of the fourth test were ambiguous; partial combustion may have occurred.

<u>TRIAL</u> <u>NUMBER</u>	<u>AIR/FUEL</u> <u>RATIO</u>	<u>CONDENSATE</u>		<u>POWER</u> <u>LEVEL</u>	<u>WATTS</u>
		<u>WATER</u>	<u>FUEL</u>		
1	12.35	X		300	
2	13.00	X		800	
3	13.73	X		100	
4	12.92	X*	X	150	

*Smaller amount of water than trials 1-3.

Figure 5. Results of Valid Ignition Experiments with Preheating to 370°F.

END

FILMED

384

DTIC