

AD-A138 168

LASER VELOCIMETER OPTICAL TRAVERSE SCHEME: AN
INVESTIGATION OF A PROPOSED (U) AIR FORCE INST OF TECH
WRIGHT-PATTERSON AFB OH SCHOOL OF ENGI... G S KRAJCI
DEC 83 AFIT/GSO/MA/83D-2

1/2

UNCLASSIFIED

F/G 14/2

NL

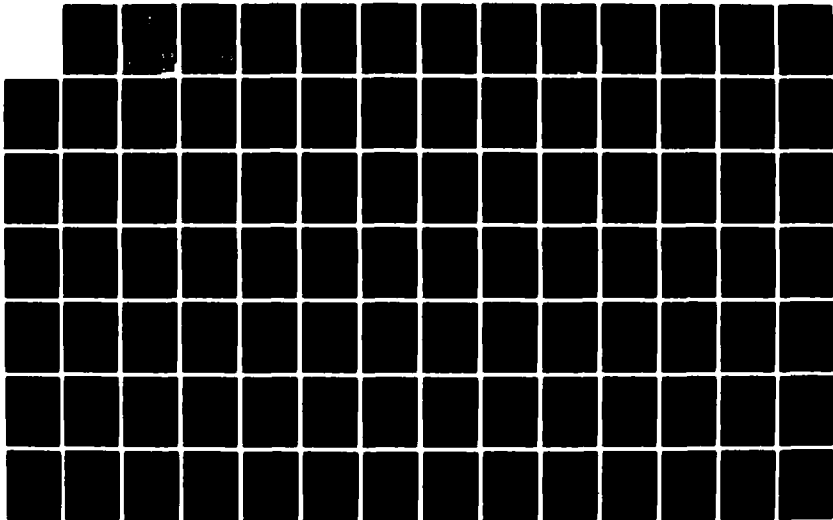

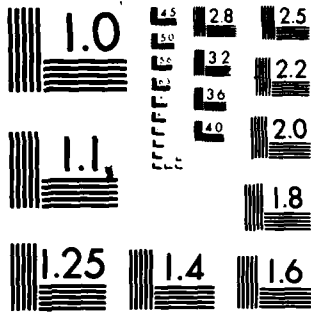

MICROCOPY RESOLUTION TEST CHART
NATIONAL BUREAU OF STANDARDS 1963-A

①

AD A138168



LASER VELOCIMETER OPTICAL TRAVERSE SCHEME
 AN INVESTIGATION OF A PROPOSED OPTICAL
 SCANNING TECHNIQUE FOR ARNOLD ENGINEERING
 AND DEVELOPMENT CENTER'S FOUR-FOOT
 TRANSONIC WIND TUNNEL

THESIS

Gary S. Krajci, B.S.
 Captain, USAF

AFTT/CSO/MA/83D-2

DISTRIBUTION STATEMENT A

Approved for public release
 Distribution Unlimited

DTIC
ELECTE
S FEB 22 1984 D

B

DTIC FILE COPY

DEPARTMENT OF THE AIR FORCE
 AIR UNIVERSITY

AIR FORCE INSTITUTE OF TECHNOLOGY

Wright-Patterson Air Force Base, Ohio

84 02 21

AFIT/GSO/MA/83D-2

LASER VELOCIMETER OPTICAL TRAVERSE SCHEME:
AN INVESTIGATION OF A PROPOSED OPTICAL
SCANNING TECHNIQUE FOR ARNOLD ENGINEERING
AND DEVELOPMENT CENTER'S FOUR-FOOT
TRANSONIC WIND TUNNEL

THESIS

Gary S. Krajci, B.S.
Captain, USAF

AFIT/GSO/MA/83D-2

DTIC
ELECTE
S FEB 22 1984 D
B

Approved for public release; distribution unlimited

AFIT/GSO/MA/83D-2

LASER VELOCIMETER OPTICAL TRAVERSE SCHEME:
AN INVESTIGATION OF A PROPOSED OPTICAL SCANNING TECHNIQUE
FOR ARNOLD ENGINEERING AND DEVELOPMENT CENTER'S
FOUR-FOOT TRANSONIC WIND TUNNEL

THESIS

Presented to the Faculty of the School of Engineering
of the Air Force Institute of Technology
Air University
In Partial Fulfillment of the
Requirements for the Degree of
Master of Science in Space Operations

Gary S. Krajci, B.S.

Captain, USAF

December 1983

Approved for public release; distribution unlimited

Preface

The purpose of this study was to investigate a proposed scanning technique for a laser Doppler velocimeter (LDV). This LDV setup uses an azimuth-elevation (az-el) mirror and a lens to move the probe volume to various points of interest in the wind tunnel rather than moving an entire stationary optical table.

The approach taken was to write a computer program which calculated the location of the probe volume given the orientation of the mirror and position of the lens with respect to the mirror. Because of the results generated by this computer code, the study objectives were redefined to study the conditions necessary for convergence of the laser velocimeter's beams.

To complete the study, an LDV system is proposed which will guarantee convergence by circumventing the rigid geometry of the original LDV system. Also, a computer program is provided to determine the orientation of the LDV system for measurement of the x- and y-components of velocity.

I would like to thank my faculty readers LtCol Ivy Cook and Maj James Lange for their support, guidance, and insight into problem solving. A very special thanks goes to my advisor LtCol Richard Kulp for his guidance, patience, and understanding. A special word of thanks to Clarence Edstrom for his invaluable aid in solving some problems. Also to Virgil Cline for suggesting this interesting topic, for

Whoever appeals to authority applies not his reason, but his memory....No human investigation can call itself true science, unless it comes through mathematical demonstration

- Leonardo da Vinci

Last but not least, I would like to dedicate this thesis to my wife
Chong Hui and my son Christopher who supported me through this endeavor.

Gary S. Krajci

| | |
|------------------------------|-------------------------------------|
| Accession For | |
| NTIS GRA&I | <input checked="" type="checkbox"/> |
| DISC TAB | <input type="checkbox"/> |
| Unannounced Justification | <input type="checkbox"/> |
| By | |
| Distribution/ | |
| Availability Codes | |
| Dist | Avail and/or Special |
| A-1 | |



Table of Contents

| | Page |
|--|------|
| Preface | ii |
| List of Figures | vi |
| List of Tables | viii |
| List of Symbols | ix |
| Abstract | x |
| I. Introduction | 1 |
| Background | 1 |
| Problem Statement | 8 |
| Objectives | 8 |
| Methodology | 9 |
| II. Laser Doppler Velocimeter Setup | 12 |
| III. X-Y Plane Analysis | 17 |
| Lens to Mirror | 17 |
| Mirror to Window | 20 |
| Through the Window | 25 |
| Window to Tunnel | 30 |
| Coordinate Transformation | 32 |
| IV. Y-Z Plane Analysis | 34 |
| V. Velocity Transformation | 42 |
| VI. Convergence Criteria | 46 |
| VII. Tunnel Point to LDV Orientation | 63 |
| VIII. Results, Conclusions and Recommendations | 73 |
| Results | 73 |
| Conclusions | 73 |
| Recommendations | 74 |
| Bibliography | 76 |
| Appendix A: Probe Volume Analysis | 78 |

| | Page |
|--|------|
| Appendix B: Laser Doppler Velocimeter Program Listing | 87 |
| Appendix C: Tunnel Point to LDV Orientation Program Listing | 109 |
| Vita | 126 |

List of Figures

| Figure | | Page |
|--------|--|------|
| 1.1 | Nonstandard laser velocimeter setup proposed for use in AEDC Wind Tunnel 4T | 2 |
| 1.2a | Setup for creating a probe volume | 4 |
| 1.2b | Beam intersection region showing fringes formed in the ellipsoidal volume | 4 |
| 1.2c | Doppler burst signal produced by a particle having a velocity component normal to the fringe | 4 |
| 1.3 | Standard laser velocimeter setup | 6 |
| 2.1a | Relationship between mirror RCCS and tunnel RCCS | 13 |
| 2.1b | Measurement of θ | 13 |
| 2.1c | Measurement of ϕ | 13 |
| 2.1d | Az-El mirror | 14 |
| 2.1e | Relative position/orientation of LDV and tunnel elements | 14 |
| 2.1f | Designation of points and vectors | 15 |
| 3.1a | Geometry of lens and laser beams | 18 |
| 3.1b | Relationship between laser beam lines and mirror lines | 18 |
| 3.2 | Relationship between virtual image and object image for reflection at a plane surface | 21 |
| 3.3 | Relationship between (x,y,z) and (x',x',z') coordinate systems | 22 |
| 3.4 | Relationship between (x',y',z') and (x'',y'',z'') coordinate systems | 23 |
| 3.5 | Representation of reflected rays off mirror | 26 |
| 4.1 | Geometry and designation of laser beams originating in the y-z plane | 35 |
| 4.2 | Location of rays in Table II which fall on tunnel access window | 39 |

| Figure | Page |
|---|------|
| 5.1 Orientation of probe volume | 43 |
| 5.2 Vector addition of unit vectors | 44 |
| 6.1 Designation of points and vectors for convergence analysis | 49 |
| 6.2 Illustration of laser beam paths | 56 |
| 6.3 Geometry of convergence criteria | 57 |
| 6.4 Graph of θ versus ϕ for $Y_7 = 0$ | 61 |
| 6.5 Graph of ϕ versus Y_7 for various values of θ | 62 |
| 7.1 Four mirror device | 64 |
| 7.2 Scheme for finding α_1 given a point in the tunnel | 67 |
| 7.3 Vector addition | 70 |
| A.1 Probe volume formed by overlapping laser beams | 78 |
| A.2 Plot of laser beam overlap for $\theta = 42$ degrees | 80 |
| A.3 Plot of $\phi = 0$ and $22 < \theta < 68$ degrees | 81 |
| A.4 Plot of distance between probe volume centers for $\phi = 0$ | 82 |
| A.5 Graph of useable region for the conditions of minimum distance between laser beams < 0.1 mm and distance between probe volume centers < 1.0 mm | 83 |
| A.6 Graph of useable region for the conditions of minimum distance between laser beams < 0.05 mm and distance between probe volume centers < 1.0 mm | 85 |
| A.7 Graph of useable region for the conditions of minimum distance between laser beams and probe volume centers < 0.05 mm | 86 |

List of Tables

| Table | Page |
|---|------|
| I. Results of ray trace for $(\theta, \phi) = (34, -22)$ | 38 |
| II. Results for various orientations of θ and ϕ | 40 |
| III. Comparison of single-mirror and four-mirror system | 72 |

List of Symbols

Roman Letter Symbols

- d_1 - distance from lens to mirror
- d_2 - distance from mirror to tunnel rectangular Cartesian coordinate system (RCCS) origin
- d_3 - distance from mirror RCCS origin to the tunnel access window
- f - focal length of lens
- L1 - lens used in LDV system
- M1 - az-el mirror for LDV system
- n_i - index of refraction for medium i
- P_i - point i , in the analysis, where a vector falls upon some surface or a designated location
- s - distance between the laser beams entering the lens
- \vec{V}_i - vector i , in the analysis, used to describe the trace of the laser beams at various locations
- \vec{V}_{ij} - the j th component of the i th vector
- w - thickness of the window
- x_i, y_i, z_i - the x -, y -, and z -coordinates of the point P_i

Greek Letter Symbols

- $\alpha_1, \alpha_2, \alpha_3$ - the direction cosines in the x , y , and z direction, respectively
- δ - angle used to determine the location of the mirror normal ($\delta = \theta - 90$)
- ϵ - angle between the plane of the lens and the V_1 or V_2
- ϕ - angle made by the normal to the mirror and the x - y plane which determines the elevation of the mirror
- θ - angle made by the mirror and the x -axis which determines the azimuth of the mirror

Abstract

This investigation analyzed a nonstandard laser velocimeter setup proposed for use in AEDC Wind Tunnel 4T. The setup uses a gimbaled mirror to move the probe volume from point to point, and the translation of a lens to control the distance in the tunnel the probe volume reaches.

Results show that for equal indices of refraction inside and outside the tunnel, the laser beams of a converging pair do not totally converge with its associated beam except under certain conditions, and the probe volumes created by each pair of overlapping laser beams do not always coincide. This work then provides the conditions necessary for total convergence of a pair of laser beams for this setup.

A solution is then proposed to insure convergence of each laser beam pair and overlap of the two probe volumes. More than a solution to the above problems, a method is given to determine the azimuth and elevation angles for a mirror such that the reflected beam off the mirror passes through a given point in the tunnel after traversing a window.

To carry out these investigations, a computer code was written to simulate the nonstandard laser velocimeter setup, and a second code was written to determine the azimuth and elevation angles for a mirror such that the reflected beam off the mirror passes through a given point in the tunnel after traversing a window. Both codes were written in FORTRAN 77, implemented on a CDC 6000 - CYBER 74, and listed in the report.

LASER VELOCIMETER OPTICAL TRAVERSE SCHEME:
AN INVESTIGATION OF A PROPOSED OPTICAL SCANNING TECHNIQUE
FOR ARNOLD ENGINEERING AND DEVELOPMENT CENTER'S
FOUR-FOOT TRANSONIC WIND TUNNEL

I. Introduction

Background

Arnold Engineering Development Center (AEDC) uses a 4-foot Transonic Wind Tunnel (4T) to obtain performance data on and assess the effect of modifications to aerodynamic models. Performance data is in the form of the velocity and position of the boundary layers around the model. Of particular interest is the velocity of the flow angle particles in the test section of the wind tunnel. Flow angle particles are those particles entrained in the wind tunnel flow which bounce off the walls of the wind tunnel and the surface of the model. These flow angle particles travel in paths at angles to the flow and obscure the aerodynamic characteristics of the test article by introducing unwanted velocities measured by the detector (Ref 5:5). To measure both the wanted and unwanted velocities, a laser Doppler velocimeter (LDV) is used. Even though the LDV offers a more accurate means of analyzing air flow in the wind tunnel than conventional probes, the proposed geometry of the LDV setup for 4T (Figure 1.1) presents a problem in ascertaining the position of and confidence in the velocity measured. Before these problems are addressed, the concept of the LDV must be understood.

The laser Doppler velocimeter utilizes the laser light, scattered from the particles entrained in the flow of interest, to measure the

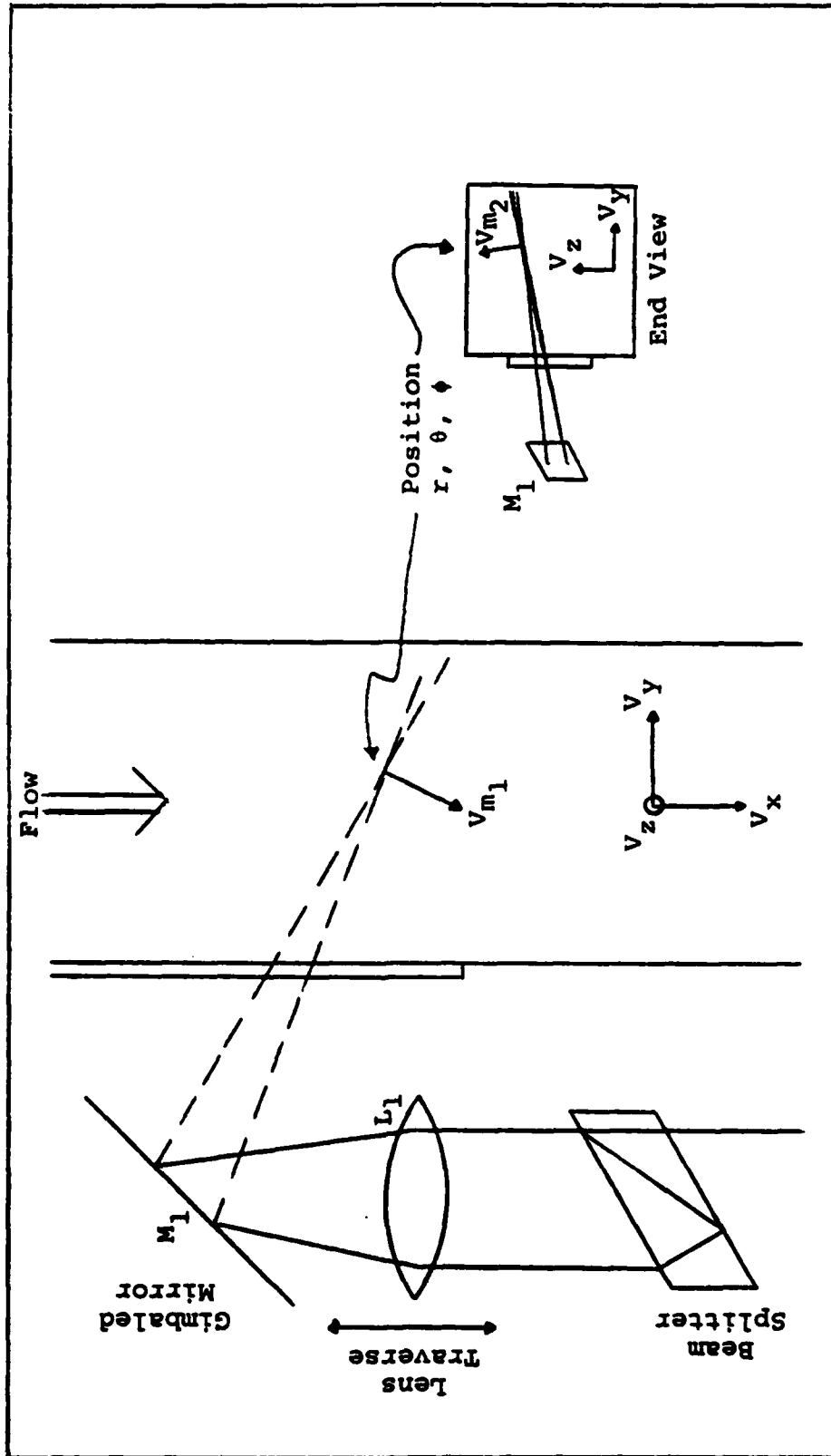

Figure 1.1. Nonstandard laser velocimeter setup proposed for use in AEDC Wind Tunnel 4T.

particle's velocity (Ref 2,4,6, and 15). This velocity measurement is determined as the particles pass through a set of interference fringes created by the laser light. The fringe set, called the "probe volume", is created by intersecting two laser beams at the point of interest (Figure 1.2). Because the two laser beams are coherent and identically polarized, they will interfere constructively and destructively to establish a set of closely spaced, planar interference fringes (bright and dark regions) in the probe volume (Figure 1.2). The velocimeter detects the velocity of the particles (scatterers) entrained in the flow as they pass through the probe volume and intercept the interference fringes. The fringes will cause the scatterers to alternately scatter then not scatter light into the detector. A velocity magnitude is calculated by heterodyning the scattered laser radiation (which is Doppler shifted in frequency due to the movement of the scattering medium) with unscattered, reference radiation (Ref 3:40-43). The measured velocity component is perpendicular to the bisector of the angle between the two beams and is in the plane of the two beams. A second set of fringes, orthogonal to the first set and of a different wavelength, is created so that another set of components can then be measured. This second set of fringes coincides with the first set and measures its velocity component simultaneously with the first set. The fringes are oriented such that one component is horizontal and one vertical.

To survey the flow in a wind tunnel, the probe volume must be moved from point to point. For this purpose, most LDV systems are mounted on a traverse system which provides three orthogonal directions of movement. When the traverse system is aligned with the tunnel's co-

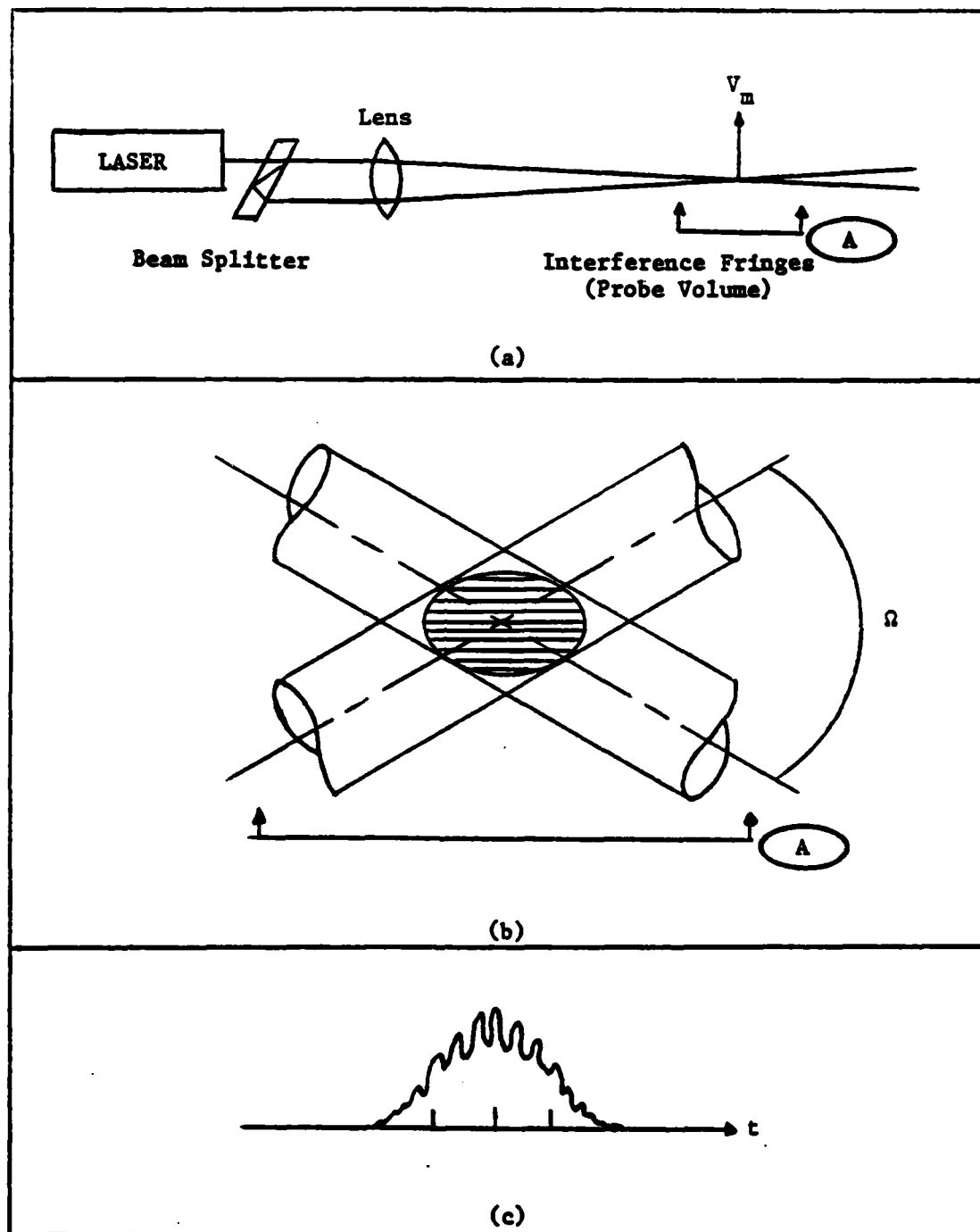

Figure 1.2. (a) Setup for creating probe volume.
 (b) Beam intersection region showing fringes formed in the ellipsoidal volume.
 (c) Doppler burst signal produced by a particle having a velocity component normal to the fringes.

ordinate system, the spatial position of the probe volume can be read out directly in the tunnel's Cartesian coordinate system. This, of course, requires a test section at least as large as the required traverse distances (Figure 1.3).

For the test facilities with limited optical access and large volumes of interest in the flow, an optical scanning technique, such as schematically shown in Figure 1.1 may be required. Movement of the gimbaled mirror (M1) controls angles θ and ϕ , and translation of lens L1 controls the distance r for the probe volume position in a fixed coordinate system centered on M1.

AEDC Wind Tunnel 4T is a system which requires such a nonstandard optical scanning technique. "The development of an LDV system capable of operating within Tunnel 4T required numerous innovations and compromises due to the many environmental constraints imposed by the wind tunnel" (Ref 5:6). The fundamentals of optical design for standard LDV systems are well established (Ref 7:11). However, the innovations and compromises in the LDV setup for Tunnel 4T present problems in determining the position and velocity measurements of particles entrained in the flow. AEDC has asked that these problems be studied because, at this time, Tunnel 4T is unuseable.

Since the traverse system is not aligned with the tunnel's Cartesian coordinate system (Figure 1.1), the spatial position of the probe volume is not readily known. Therefore, the experimenter cannot locate the boundary layers around the aerodynamic model and assess the model's performance. Using the gimbaled mirror as the origin of a spherical coordinate system and the position of the lens, a set of

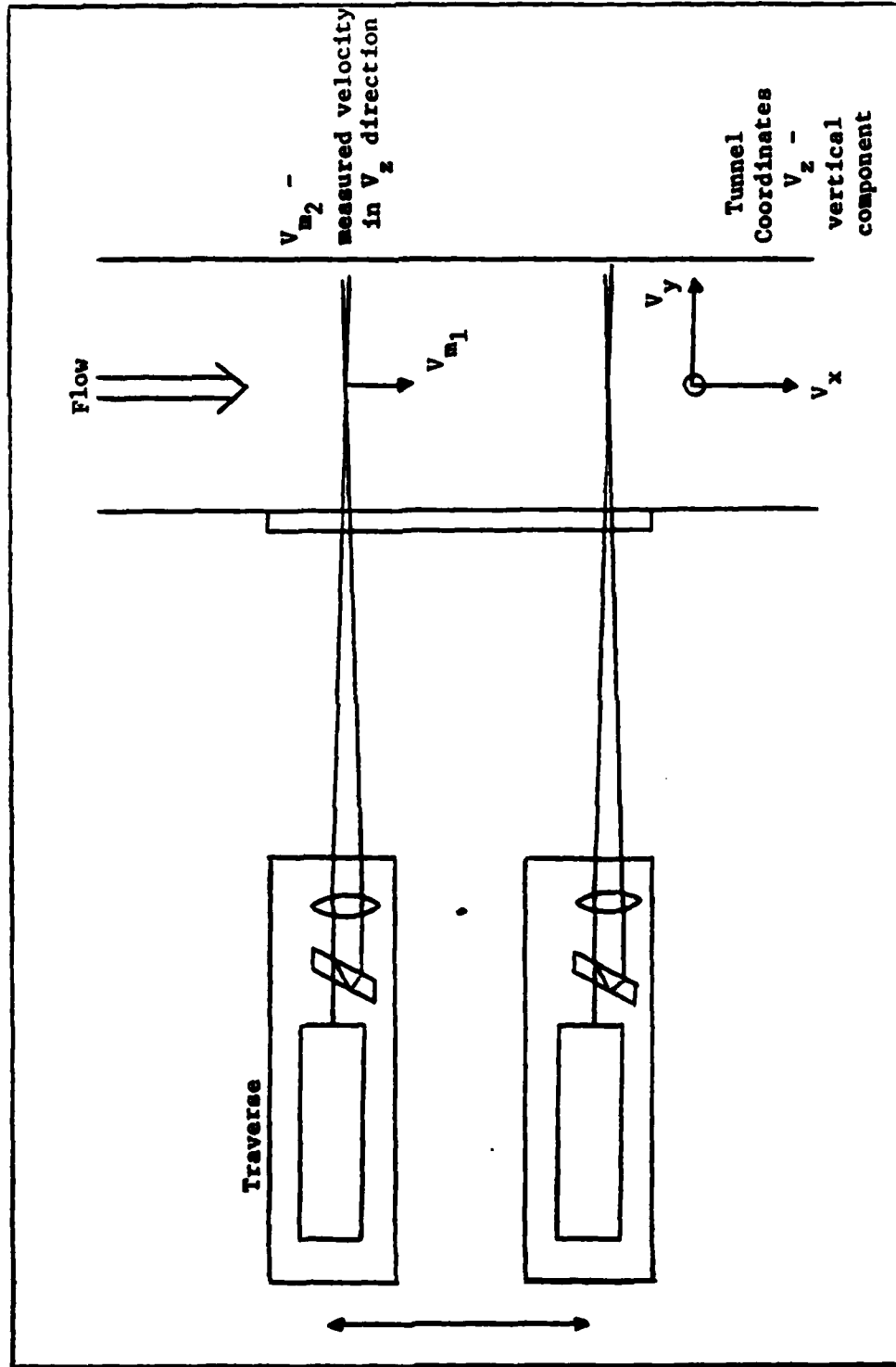

Figure 1.3. Standard laser velocimeter setup.

equations (or a coordinate transformation matrix) needs to be developed to relate the LDV spherical coordinates to the tunnel's Cartesian coordinates. Then, given the position of the mirror and the position of the lens relative to the mirror, the location of the probe in the wind tunnel can be determined relative to the origin of the tunnel's Cartesian coordinate system.

Once the position of the probe volume is known, the velocity of the flow can be measured. Or can it? Errors in velocity measurement occur when the embedded particles' paths through the probe volume vary significantly from the direction perpendicular to the fringe. This leads to a reduction in the number of fringes crossed and can cause a rejection of the reading by the detection device. Thus, the probe volume has a variable "polar response" and the measured mean velocity would be high for that velocity component (Ref 16:7). This polar response could be due to the paths of the flow angle particles or the gimbaled mirror position being at some angle where the probe volume is not perpendicular to the tunnel. In the latter instance, the measured velocity components need to be transformed into the tunnel system coordinates because the probe volume is measuring a polar response and not the actual velocity of the particles in the boundary layer. Another problem associated with the polar response is measuring the flow angle particles along with the particles in the boundary layer. Regardless of the probe volume position or location, the flow angle particles induce unwanted biases into the analysis of the model's aerodynamic response.

The above problems hinder the experimenter from using Tunnel 4T

for any testing of aerodynamic models. The investigation into these areas may lead to a solution such that the tunnel will be a productive instrument.

Problem Statement

Since there is no way to determine the position of the particles and no confidence in the velocity measurements, four problems arise:

1. The problem of determining the location of the probe volume in the wind tunnel coordinate system given the orientation of the laser Doppler velocimeter lens and mirror,
2. The problem of determining the velocity of the particles when the mirror is off angle,
3. The problem of determining the uncertainties in the position of the measurements,
4. The uncertainties in whether the velocity measured was that of the boundary layer and not that of a flow angle.

Objectives

The overall objective of this research is to investigate and resolve the limitations of the laser Doppler velocimeter optical traverse scheme for Tunnel 4T. This task will require:

1. Developing the equations to transform the spatial position from the laser velocimeter spherical coordinates to the tunnel Cartesian coordinates,
2. Developing the equations to transform the measured velocity components into the components of the tunnel system,
3. Performing an uncertainty analysis showing the accuracy re-

quired in knowledge of the spherical system coordinates to provide uncertainties in the tunnel system position of less than 0.001 inch in each direction (Ref 5:32-39),

4. Determining a sampling scheme of the probe volume such that the confidence in the measured velocities are those of the boundary layer and not of the flow angle particles (Ref 1,9, and 13).

Methodology

The unique design of the Arnold Engineering Development Center's (AEDC) laser Doppler velocimeter (LDV) setup did not lend itself to the usual analysis of an LDV system (Ref 7). Rather than operating in a plane, this system operates in three-dimensional space which required the application of a different set of procedures and the development of new analytical procedures to analyze the system. During the investigation, this system produced results which were not expected. Specifically, the setup, illustrated in Figure 1.1, causes each laser beam of a converging pair not to totally converge with it's associated beam except under certain conditions. Also, the probe volumes created by each pair are not always totally coincident and may therefore measure the incorrect velocity. These results led to a redefinition of the study objectives. To be useful to AEDC, the analysis includes determining the coordinate transformation equations between the LDV and tunnel rectangular Cartesian coordinate systems (RCCS), the velocity transformation of this measurement, conditions for convergence of the laser beams, and, given a point in the tunnel, determining the conditions of the LDV system to access that point for a velocity measurement.

To study these objectives, it was necessary to implement the ana-

lytic procedures into two computer codes to facilitate the calculation of results. The first code (Appendix B) provides the location of the probe volume in the tunnel coordinate system, the probe volume angle, and the velocity transformation matrix for both sets of laser beams given the orientation of the mirror. The second code (Appendix C) calculates the azimuth and elevation angles for a mirror such that the reflected beam off the mirror passes through a given point in the tunnel after traversing a window and the probe volume angles for each pair of laser beams.

Coordinate Transformation. The coordinate transformation from the mirror to the tunnel RCCS is a rotation and translation of the mirror coordinate axes based upon the geometry of the LDV setup. Given this transformation, the location of the probe volume in the mirror RCCS is needed. This location is based on the orientation of the mirror and the location of the lens with respect to the mirror. Once the location of the probe volume is determined, the location of the measured velocity is known and also, based on the location analysis, the orientation of the probe volume is known.

Velocity Transformation. Based upon the orientation of the laser beams which traverse the wind tunnel, a probe volume RCCS can be created. Using this RCCS, the necessary transformation matrices can be computed which will transform the measured velocity from the probe volume coordinate system to the mirror coordinate system.

Convergence. Normally convergence of the laser beams is not a consideration when conducting an LDV run. However, during the analysis of the proposed LDV setup, the lines representing the laser beams failed

to converge under certain conditions. Even though these lines are sometimes skew, due to the finite size of a laser beam, there may still be some overlap of the laser beams which may be enough to form a useable probe volume. The approach then is to determine the necessary conditions for convergence of the laser beams for this LDV setup.

Proposed Modification to the AEDC LDV Setup. Knowing that under certain conditions the laser beams in the proposed LDV setup may not totally overlap, a modification is proposed which may satisfy AEDC's requirement for an LDV system to be used in Tunnel 4T. This modification introduces two variables: four mirrors vice one and a changing probe volume angle, but assures total overlap of the laser beams to produce a useable probe volume.

II. Laser Doppler Velocimeter Setup

Based upon the nature of the laser Doppler velocimeter (LDV) setup in Figure 1.1, the following and subsequent discussions trace the laser beams from the lens to their final destination in the wind tunnel.

Preliminary to the analysis, it is necessary to present the conventions used with this setup. Based on Figure 1.1; the mirror rectangular Cartesian coordinate system (RCCS) was defined such that the z-axis was oriented the same as the tunnel's z-axis and the system was right-handed. The relationship between the tunnel RCCS and the mirror RCCS is illustrated in Figure 2.1a. The orientation of the mirror is determined by the angles θ and ϕ (as defined in the List of Symbols), and illustrated in Figures 2.1b and 2.1c. The mirror is mounted on an az-el (azimuth - elevation) mount such that the center of the mirror never changes regardless of the value for θ and ϕ (see Figure 2.1d). The center of the mirror cannot change as it is the origin of the coordinate system used to carry out the analysis. The relative position between the lens, mirror and associated RCCS, tunnel access window, and tunnel RCCS are illustrated in Figure 2.1e. These factors along with the angles θ and ϕ , the width of the tunnel access window and associated index of refraction, and the indices of refraction for inside and outside the tunnel determine the position of the probe volume in the wind tunnel. Figure 2.1f shows the location and notation of the vectors and points used in the analysis.

The analysis of the LDV system is divided into two sections -- the x-y plane and y-z plane analysis. The reason for this division is based

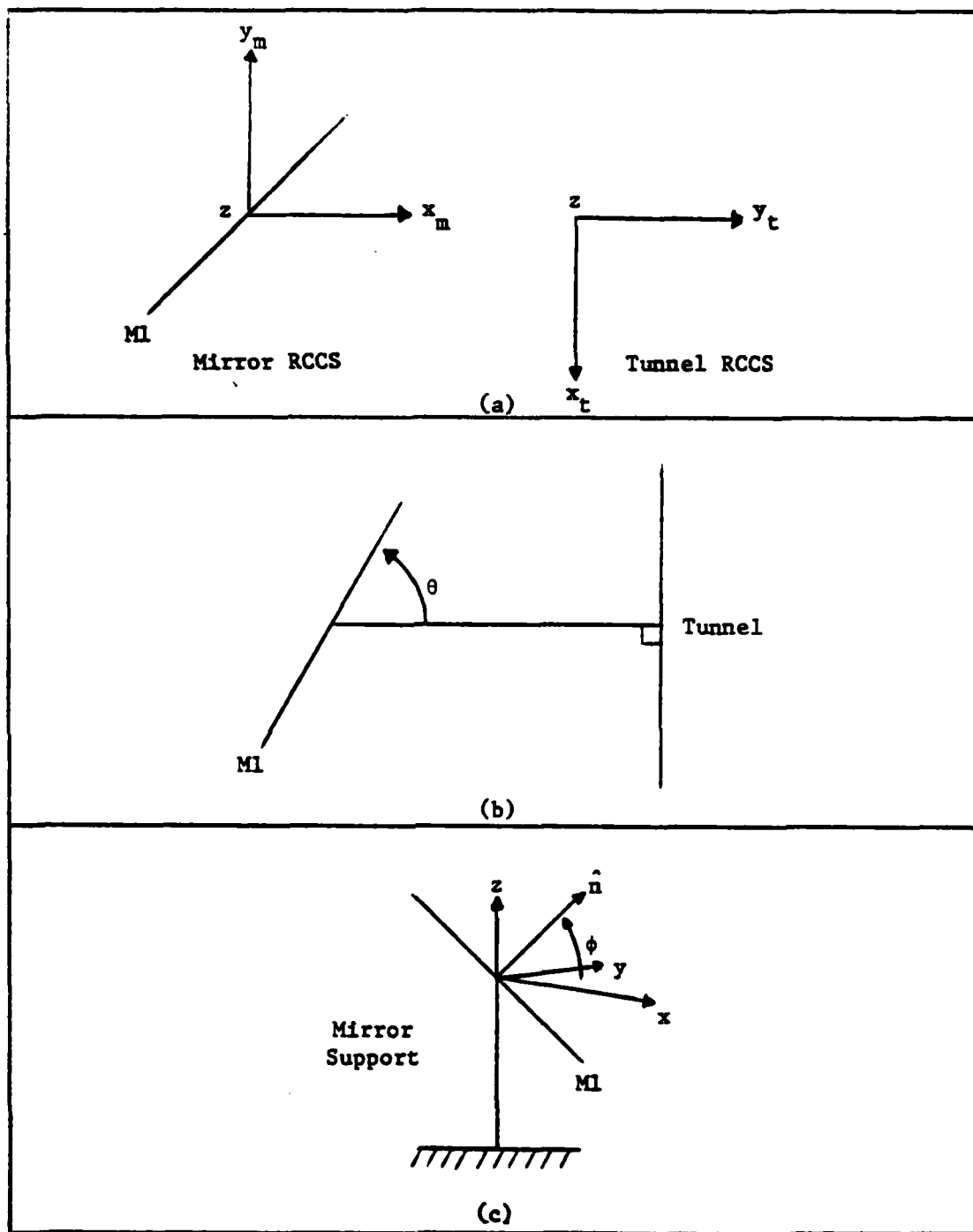

Figure 2.1. (a) Relationship between tunnel RCCS and mirror RCCS.
 (b) Measurement of θ .
 (c) Measurement of ϕ .

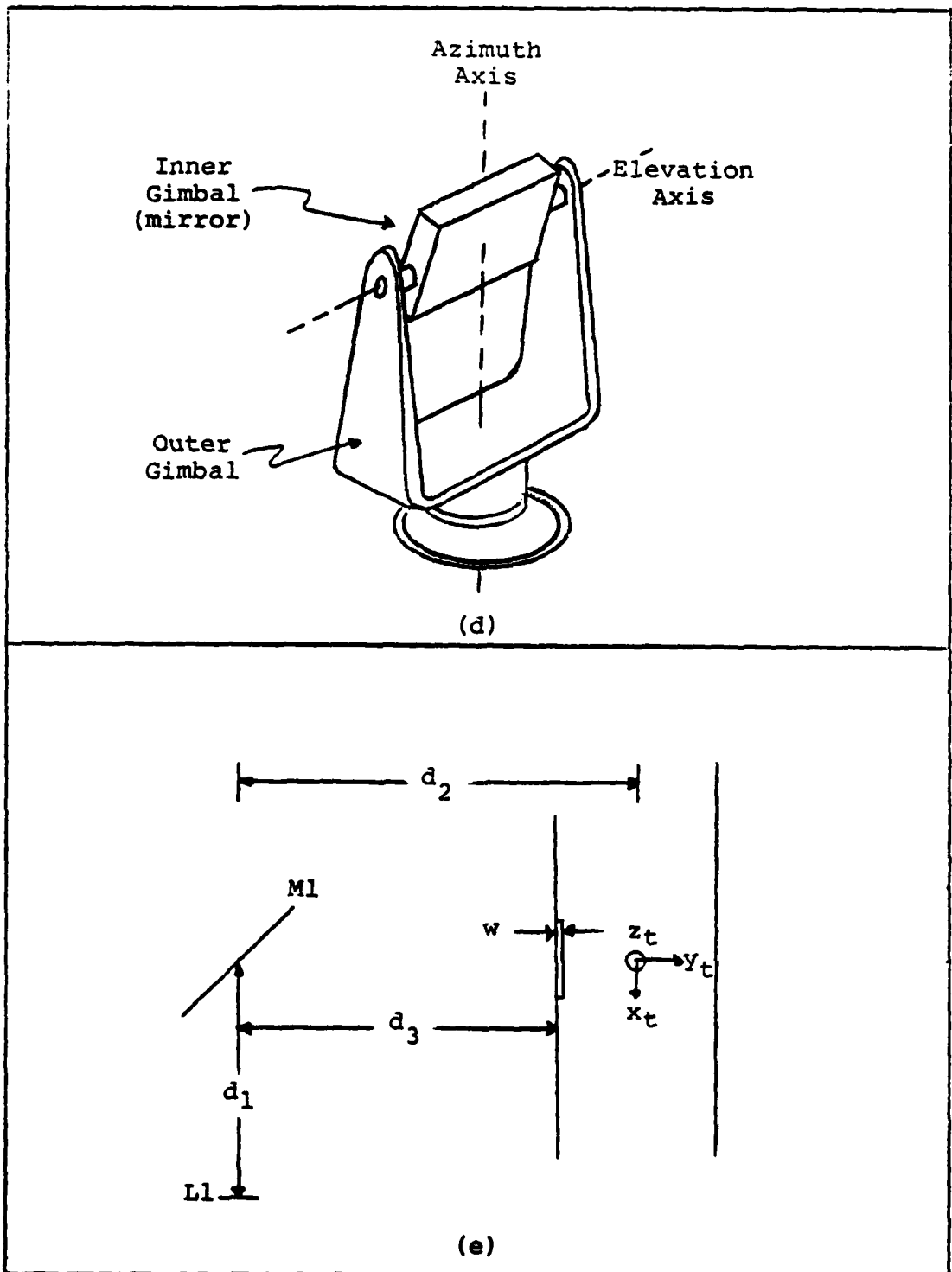

Figure 2.1. (d) Az - El Mirror
 (e) Relative position/orientation of LDV and tunnel elements.

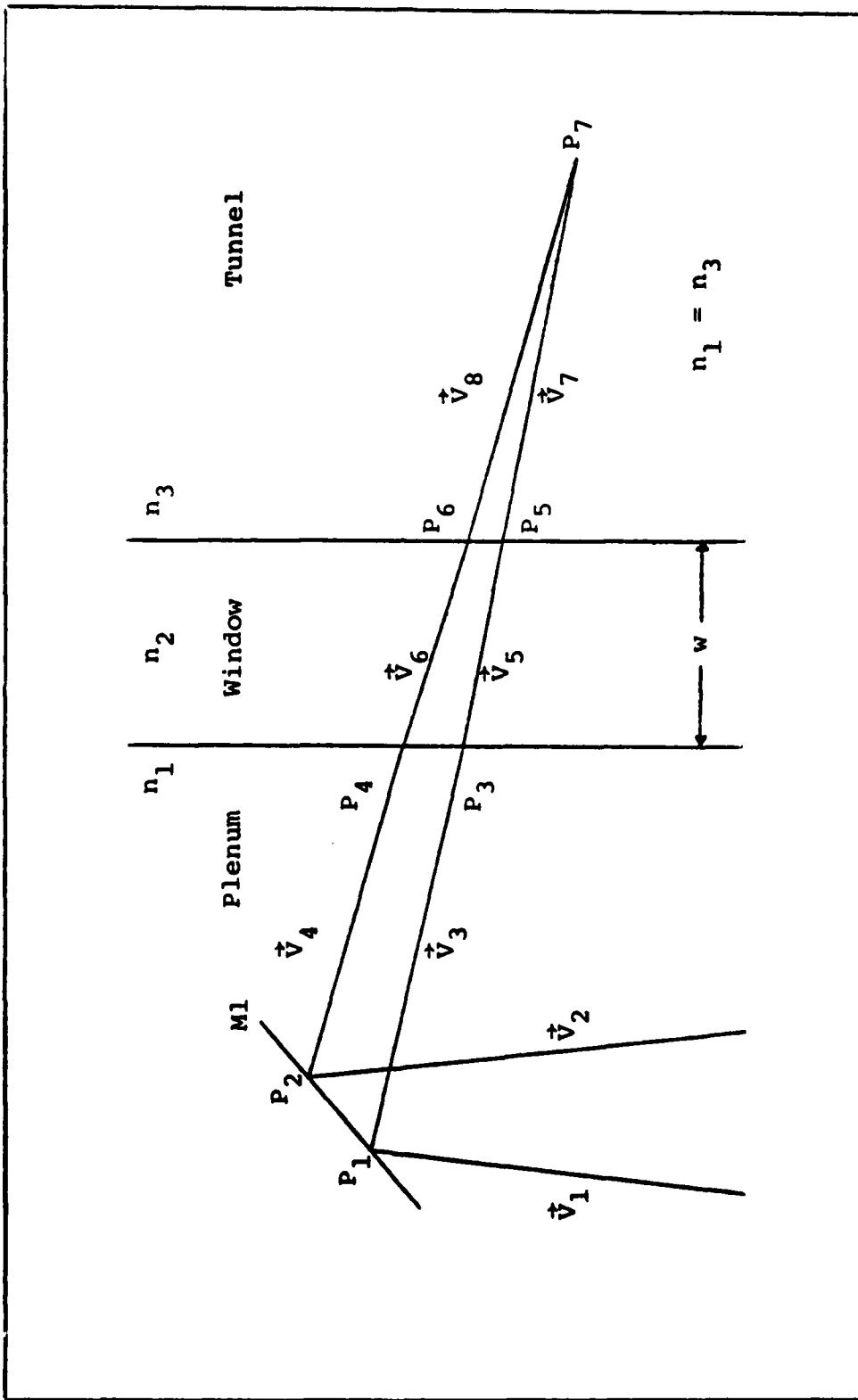

Figure 2.1f. Designation of points and vectors.

on the LDV itself. To measure a velocity in the tunnel, two probe volumes are needed -- one to measure the x-component and one to measure the y-component of velocity. When the x and y values are combined, the result represents the direction and magnitude of the velocity of the measured particle where the probe volumes are located in the tunnel. To ensure there is no interference between the two probe volumes, two laser beams of different wavelengths (colors) are used and each is split such that one color pair of beams lies in the y-z plane (to measure the y-component of velocity) and the other color pair in the x-y plane (to measure the x-component of velocity) as they pass through the lens and fall on the mirror.

III. X-Y Plane Analysis

To measure the x-component of velocity of a particle entrained in the tunnel flow, it is necessary to know the location of the probe volume in the tunnel, and for the LDV setup of Figure 1.1, the orientation of the probe volume. The following sections trace the laser beams which originate in the x-y plane from L1 as they reflect off M1 and refract through the tunnel access window to their point of intersection in the wind tunnel.

Lens to Mirror

The line diagram for the two laser beams originating in the x-y plane and passing through L1 is illustrated in Figure 3.1a. Necessary to the analysis is the angle ϵ . From Figure 3.1a and trigonometry of a right triangle (Ref 8:222), one can show that

$$\tan \epsilon = \frac{f}{s/2} = \frac{2f}{s} \quad (3.1)$$

Also from Figure 3.1a, the free space equations for \vec{V}_1 and \vec{V}_2 can be written as

$$\vec{V}_1 = s/2 \hat{i} + f \hat{j}$$

$$\vec{V}_2 = -s/2 \hat{i} + f \hat{j}$$

These vectors can be represented as line equations in the mirror RCCS by the following equations

$$\vec{V}_1: (y+d_1) = (x+s/2) \tan \epsilon \quad (3.2)$$

$$\vec{V}_2: (y+d_1) = -(x-s/2) \tan \epsilon \quad (3.3)$$

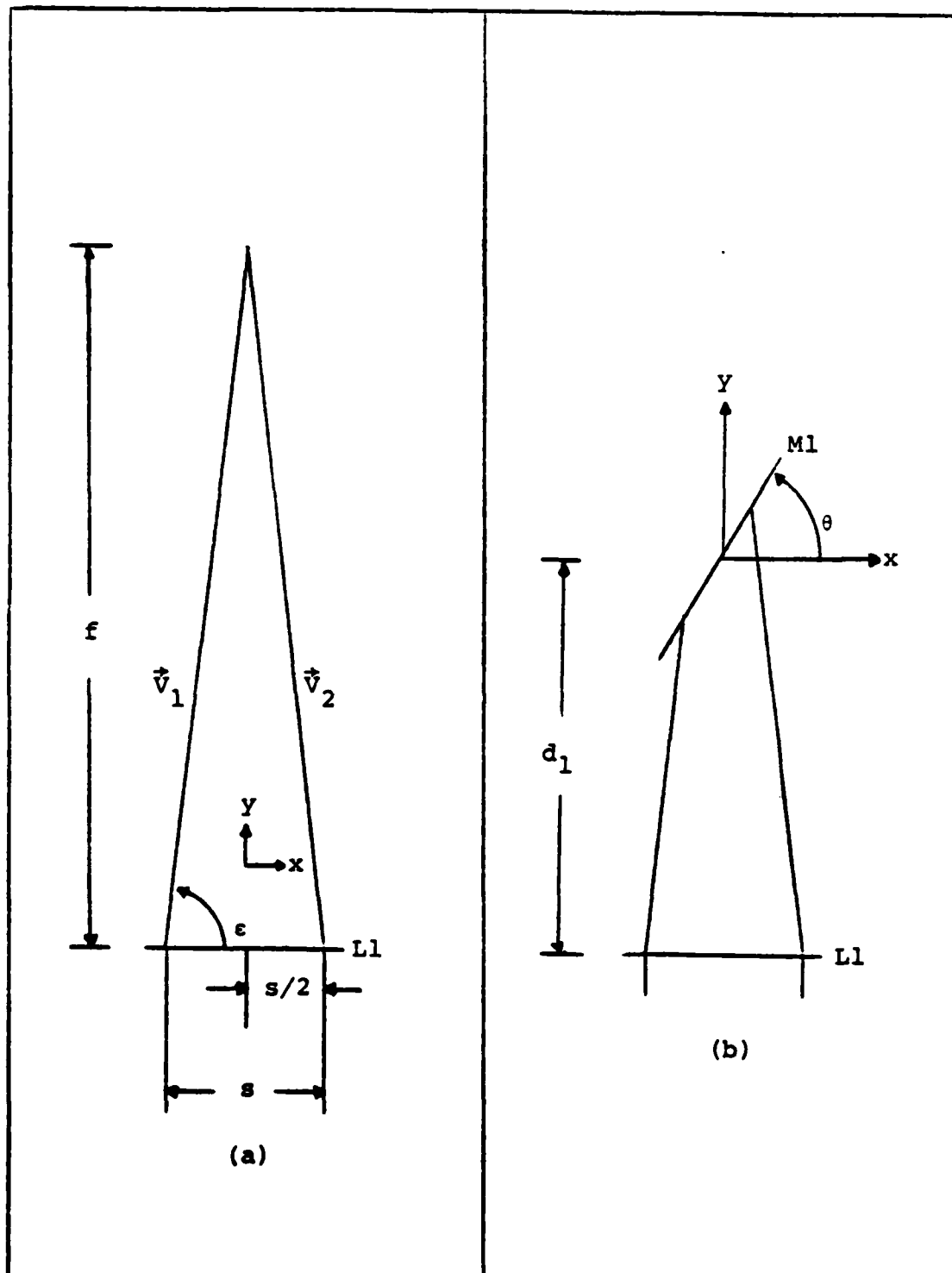

Figure 3.1. (a) Geometry of lens and laser beams.
 (b) Relationship between laser beams and mirror lines.

Writing vectors \vec{V}_1 and \vec{V}_2 as lines was done to simplify the process of finding the points where the vectors fall on the mirror. Finding these points then becomes a matter of determining the point of intersection of two lines. To do this, the mirror must also be represented by a line as seen in the x-y plane.

Since vectors \vec{V}_1 and \vec{V}_2 see the mirror in the x-y plane, they do not see any change when the mirror is moved through the angle ϕ . This is because ϕ determines the z-components of the vectors and points. Therefore, it is a simple matter to represent the mirror by the equation

$$y = x \tan \theta \quad (3.4)$$

based on the slope-intercept form of a line which goes through the origin (Ref 8:289).

The intersection of \vec{V}_1 and the mirror is $P_1 = (x_1, y_1, 0)$, which will be the point at which the laser beam will fall on the mirror (Figure 3.1b), can be found by substituting y of Equation (3.4) into (3.2). The solution is as follows

$$x_1 \tan \theta + d_1 = x_1 \tan \epsilon + (s/2) \tan \epsilon$$

$$x_1 (\tan \theta - \tan \epsilon) = (s/2) \tan \epsilon - d_1$$

$$x_1 = \frac{(s/2) \tan \epsilon - d_1}{\tan \theta - \tan \epsilon}$$

Using Equation (3.1), the solution reduces to

$$x_1 = \frac{s(f-d_1)}{s \tan \theta - 2f} \quad (3.5a)$$

and substituting into Equation (3.4)

$$y_1 = x_1 \tan \theta \quad (3.5b)$$

Similarly to find P_2 , the use of Equations (3.1), (3.3), and (3.4) to get

$$x_2 = \frac{s(f-d_1)}{s \tan \theta + 2f} \quad (3.6a)$$

$$y_2 = x_2 \tan \theta \quad (3.6b)$$

A point to remember is that P_1 and P_2 lie in the x-y plane and $z_1 = z_2 = 0$.

Mirror to Window

Once the points on the mirror where the laser beams will fall are determined, the next step is to determine the reflected vectors \vec{V}_3 and \vec{V}_4 . Vectors \vec{V}_3 and \vec{V}_4 can be determined by ignoring the window and basing the analysis on the physics of reflected light at a plane mirror (Ref 14:743-746) and illustrated in Figure 3.2. The object point at one side of the mirror lies on the extension of the normal from the virtual image point to the mirror, and that the distance of object and virtual image from the mirror are equal. Therefore, by geometry, the x and z coordinates are the same, but the y value is changed in sign in the rotated coordinate frame.

The point of intersection will be used to determine the reflected vectors from the mirror, and is determined by the rotation of the mirror through the angles θ and ϕ , and at distance $(f-d_1)$ along the reference beam $(0,1,0)$. The rotation through θ degrees is about the y-axis and determines the coordinate axes x' , y' , z' (see Figure 3.3). These values are given by the equation $AX = C$ or

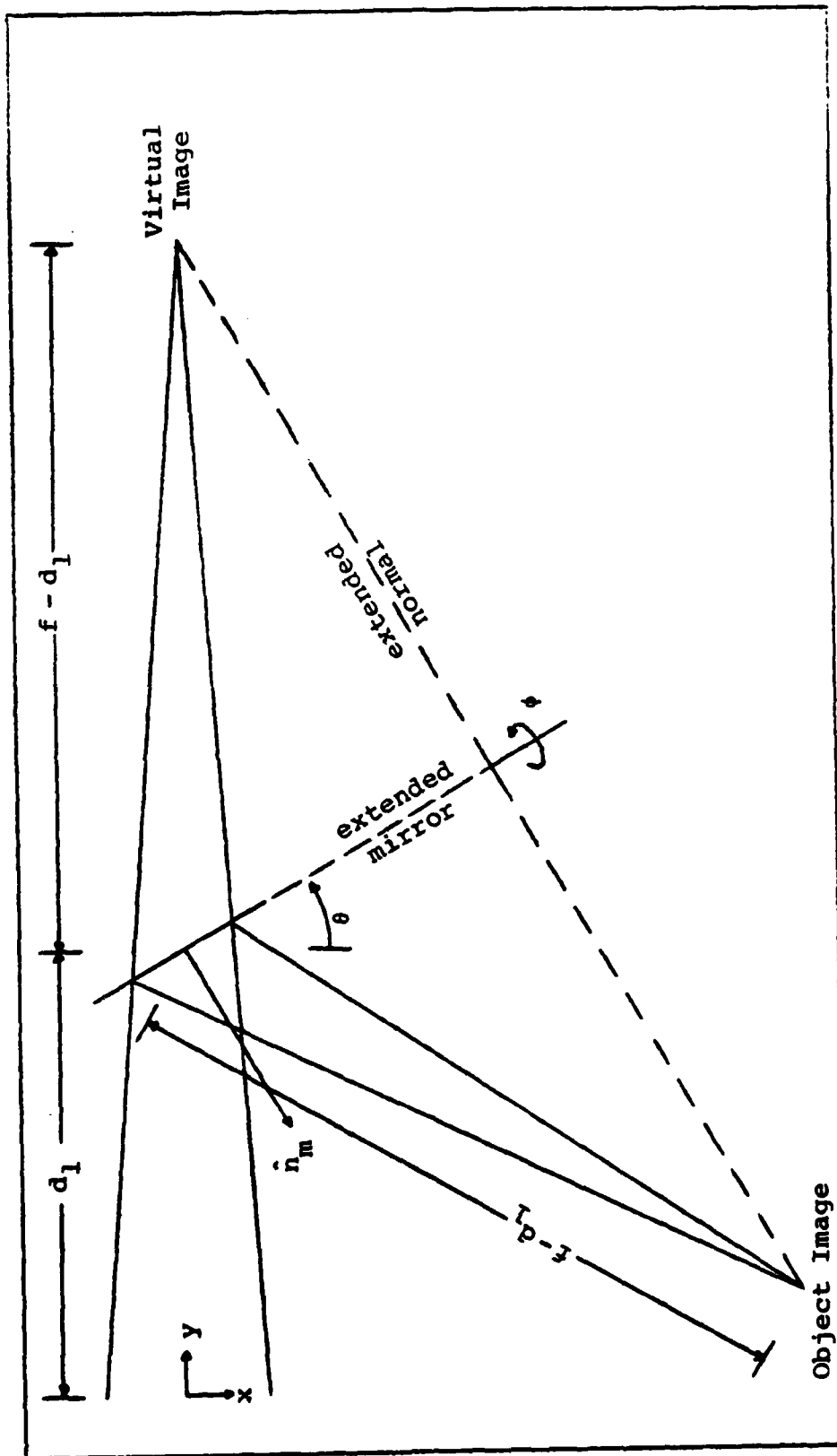

Figure 3.2. Relationship between virtual image and object image for reflection at a plane surface.

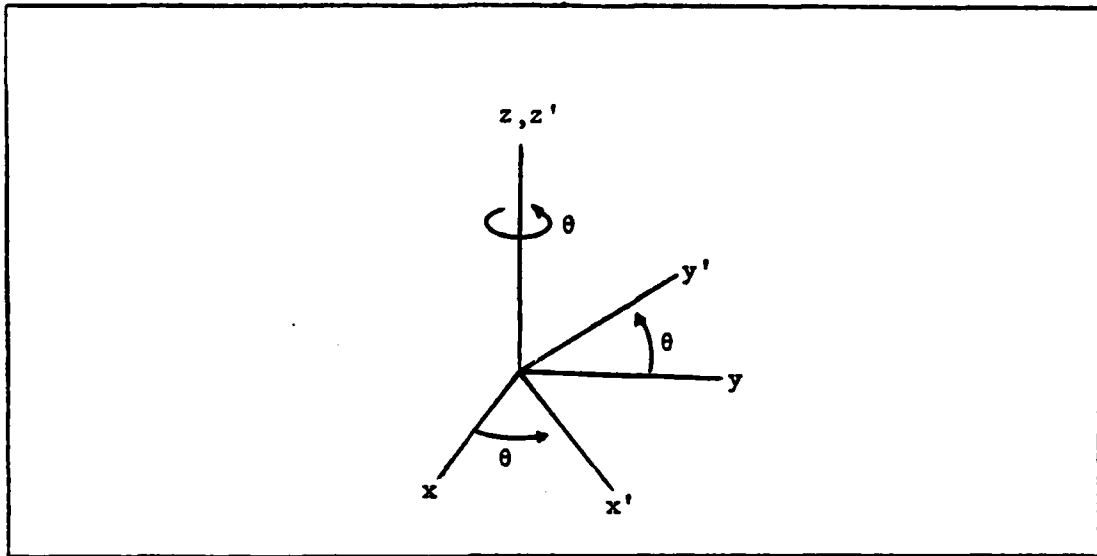

Figure 3.3. Relationship between (x,y,z) and (x',y',z') Coordinate Systems

$$\begin{bmatrix} \cos\theta & \sin\theta & 0 \\ -\sin\theta & \cos\theta & 0 \\ 0 & 0 & 1 \end{bmatrix} \begin{bmatrix} x \\ y \\ z \end{bmatrix} = \begin{bmatrix} x' \\ y' \\ z' \end{bmatrix}$$

The rotation through ϕ degrees is then a rotation about the x' -axis and determines the axes x'',y'',z'' (see Figure 3.4). These values are given by the equation $BC = D$ or

$$\begin{bmatrix} 1 & 0 & 0 \\ 0 & \cos\phi & -\sin\phi \\ 0 & \sin\phi & \cos\phi \end{bmatrix} \begin{bmatrix} x' \\ y' \\ z' \end{bmatrix} = \begin{bmatrix} x'' \\ y'' \\ z'' \end{bmatrix}$$

To determine the point of intersection, before reflection, in the x'',y'',z'' coordinate system, the rotation matrix E is formed as $BA = E$. This equation is used to modify the virtual image point of intersection $(0,f-d_1,0)$ to get

$$\begin{bmatrix} \cos\theta & \sin\theta & 0 \\ -\cos\phi\sin\theta & \cos\phi\cos\theta & -\sin\phi \\ \sin\phi\sin\theta & \sin\phi\cos\theta & \cos\phi \end{bmatrix} \begin{bmatrix} 0 \\ f-d_1 \\ 0 \end{bmatrix} = (f-d_1) \begin{bmatrix} \sin\theta \\ \cos\phi\cos\theta \\ \sin\phi\cos\theta \end{bmatrix}$$

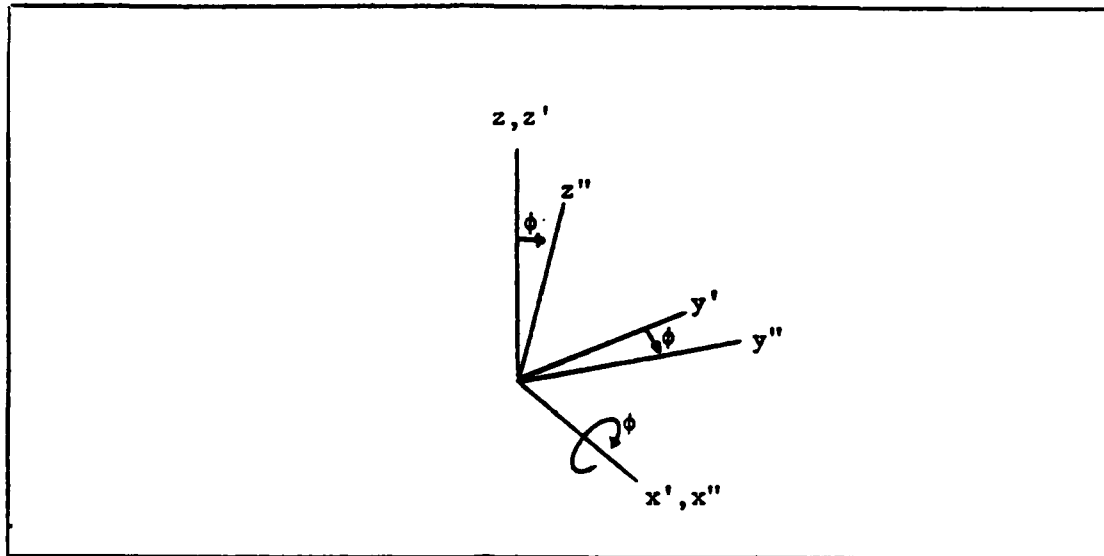

Figure 3.4. Relationship Between (x', y', z') and (x'', y'', z'') Coordinate Systems

in the x'', y'', z'' coordinate system. After the sign of the y value is changed, the location of the object point becomes

$$\underline{0} = \begin{bmatrix} x'' \\ y'' \\ z'' \end{bmatrix} = (f-d_1) \begin{bmatrix} \sin\theta \\ -\cos\phi\cos\theta \\ \sin\phi\cos\theta \end{bmatrix}$$

Now, the process is reversed to find the coordinates of vector $\underline{0}$ in the original RCCS of the mirror. To perform this calculation, the identity for Euler angles that $E^{-1} = E^T$ is needed. The point of intersection, P , is now $P = E^T \underline{0}$

$$P = (f-d_1) \begin{bmatrix} \cos\theta & -\cos\phi\sin\theta & -\sin\phi\sin\theta & \sin\theta \\ \sin\theta & \cos\phi\cos\theta & \sin\phi\cos\theta & -\cos\phi\cos\theta \\ 0 & -\sin\phi & \cos\phi & \sin\phi\cos\theta \end{bmatrix}$$

which, after using trigonometric identities and combining terms, produces

$$P = (f-d_1) \begin{bmatrix} (1+\cos 2\phi)\cos\theta\sin\theta \\ \sin^2\theta - \cos^2\theta\cos^2\phi \\ 2\cos\phi\sin\phi\cos\theta \end{bmatrix}$$

Using the point of intersection, the points on the window, and the unit vectors \hat{V}_3 and \hat{V}_4 , the reflected laser beams can be determined by subtracting the respective coordinates and dividing by the distance. Algebraically, if the point of intersection is P_7 , this results in

$$\hat{V}_{31} = \frac{(x_7-x_1)}{((x_7-x_1)^2 + (y_7-y_1)^2 + (z_7-z_1)^2)^{1/2}}$$

$$\hat{V}_{32} = \frac{(y_7-y_1)}{((x_7-x_1)^2 + (y_7-y_1)^2 + (z_7-z_1)^2)^{1/2}}$$

$$\hat{V}_{33} = \frac{(z_7-z_1)}{((x_7-x_1)^2 + (y_7-y_1)^2 + (z_7-z_1)^2)^{1/2}}$$

and similarly for P_2 ,

$$\hat{V}_{41} = \frac{(x_7-x_2)}{((x_7-x_2)^2 + (y_7-y_2)^2 + (z_7-z_2)^2)^{1/2}}$$

$$\hat{V}_{42} = \frac{(y_7-y_2)}{((x_7-x_2)^2 + (y_7-y_2)^2 + (z_7-z_2)^2)^{1/2}}$$

$$\hat{V}_{43} = \frac{(z_7-z_2)}{((x_7-x_2)^2 + (y_7-y_2)^2 + (z_7-z_2)^2)^{1/2}}$$

To continue tracing the rays through the LDV system, the points on the window where \hat{V}_3 and \hat{V}_4 fall are needed. To determine these points, the point-direction form of the line is used (Ref 8:537). Given a point and the direction cosines of the vector emanating from the point, any point on the line can be calculated. The point-direction form of a line is given by

$$\frac{x-x'}{a} = \frac{y-y'}{b} = \frac{z-z'}{c} \quad (3.7)$$

where (x',y',z') is the known point and a,b,c are the direction cosines of the vector. To find the points P_3 and P_4 on the window (see Figure 3.5), we can use the facts that the window is a plane with the equation $x = d_3$, and that $z_1 = z_2 = 0$ and Equation (3.7) to get

$$\begin{aligned} x_3 &= d_3 \\ y_3 &= y_1 + \frac{\hat{v}_{32}}{\hat{v}_{31}} (d_3 - x_1) \\ z_3 &= \frac{\hat{v}_{33}}{\hat{v}_{31}} (d_3 - x_1) \end{aligned}$$

A similar procedure using P_2 and \hat{v}_4 produces P_4 given by

$$\begin{aligned} x_4 &= d_3 \\ y_4 &= y_2 + \frac{\hat{v}_{42}}{\hat{v}_{41}} (d_3 - x_2) \\ z_4 &= \frac{\hat{v}_{43}}{\hat{v}_{41}} (d_3 - x_2) \end{aligned}$$

Through Window

Snell's law (Ref 8:16-18) says that $n_1 \sin \phi_1 = n_2 \sin \phi_2$, where ϕ_1 and ϕ_2 are the incident angle and refracted angle, respectively, and allows the calculation of the refracted light rays as they pass through media of varying indices of refraction n_1, n_2 . Given the normal to the window as $n_w = (1,0,0)$, the direction cosines of the incident ray as $(\alpha_1, \alpha_2, \alpha_3)$, the resultant ray as $(\alpha'_1, \alpha'_2, \alpha'_3)$ and the angle between the incident ray and the window normal is ϕ_1 , we can use vector analysis to

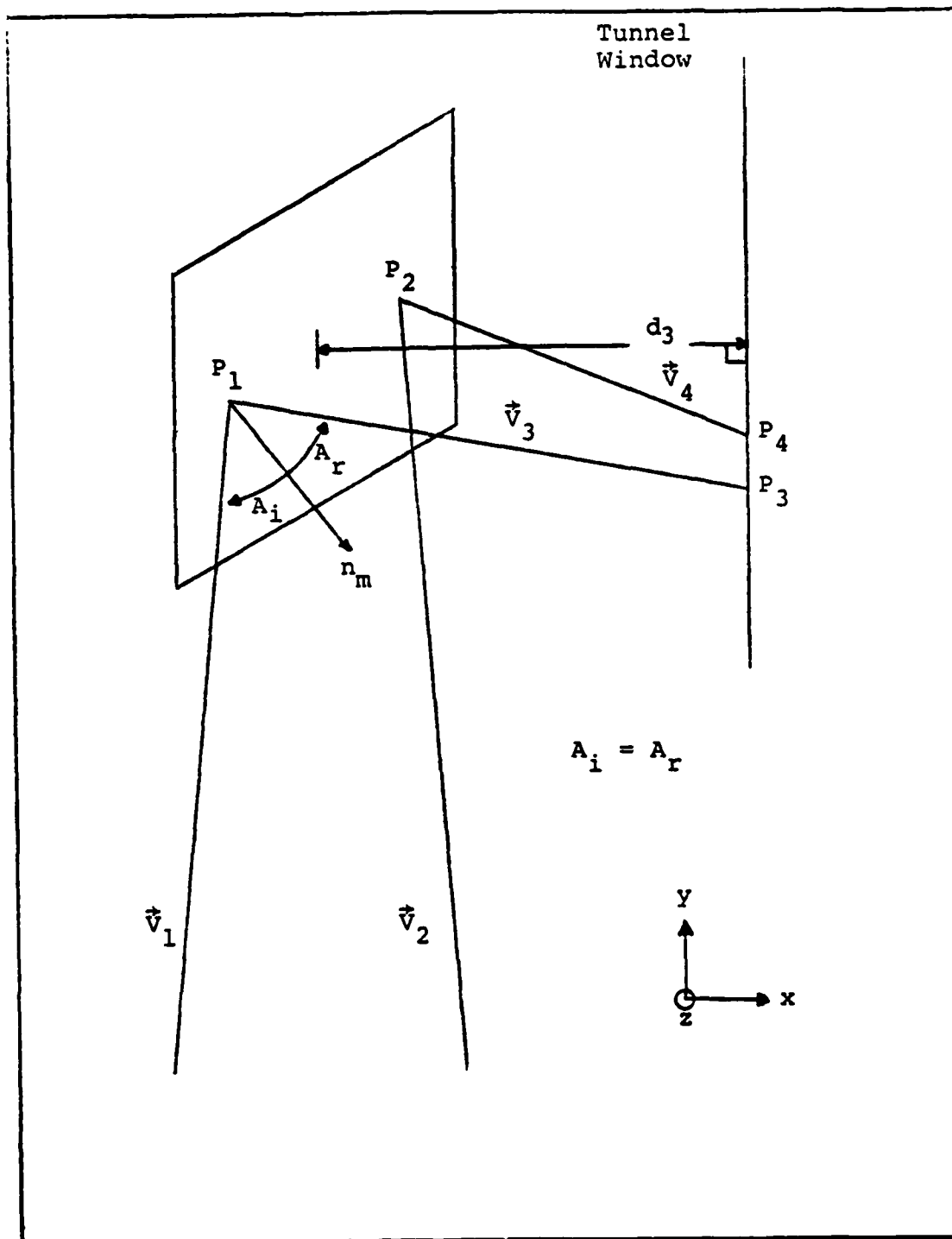

Figure 3.5. Representation of reflected rays off mirror.

find the relationship between the incident and resultant rays. Therefore, we can start with

$$\vec{V} \cdot \hat{n}_w = |\vec{V}| \cos \phi_1$$

or

$$\phi_1 = \cos^{-1} \left[\frac{\vec{V} \cdot \hat{n}_w}{|\vec{V}|} \right]$$

Since $\hat{n}_w = (1, 0, 0)$

$$\phi_1 = \cos^{-1} \alpha_1$$

and by Snell's law

$$\phi_2 = \sin^{-1} \left[\frac{n_1}{n_2} \sin(\cos^{-1} \alpha_1) \right]$$

Using the following identity

$$\sin^{-1} x = \cos^{-1} [(1-x^2)^{1/2}] \quad (3.8)$$

the resultant angle becomes

$$\phi_2 = \sin^{-1} \left[\frac{n_1}{n_2} (1-\alpha_1^2)^{1/2} \right] \quad (3.9)$$

and

$$\alpha_1' = \cos \phi_2 = \cos \left(\sin^{-1} \left[\frac{n_1}{n_2} (1-\alpha_1^2)^{1/2} \right] \right) \quad (3.10)$$

Applying Equation (3.8) to Equation (3.10) results in

$$\alpha_1' = \left[1 - \left(\frac{n_1}{n_2} \right)^2 (1-\alpha_1^2) \right]^{1/2} \quad (3.11)$$

The incident ray, refracted ray, and the normal to the window lie in the same plane. Therefore, the refracted ray can be written as a linear

combination of the incident ray and the normal, both of which are known.

Algebraically,

$$\begin{aligned} \alpha_1' i + \alpha_2' j + \alpha_3' k &= A(\alpha_1 i + \alpha_2 j + \alpha_3 k) + E i \\ &= (A\alpha_1 + B) i + A\alpha_2 j + A\alpha_3 k \end{aligned} \quad (3.12)$$

where A and B are the linear combination coefficients for which to solve.

The values of A and B will give us the relationship between the incident ray and the refracted ray. From Equations (3.11) and (3.12),

$$A \alpha_1 + B = \left[1 - \left(\frac{n_1}{n_2}\right)^2 (1 - \alpha_1^2) \right]^{1/2}$$

and squaring both sides

$$A^2 \alpha_1^2 + 2AB\alpha_1 + B^2 = 1 - \left(\frac{n_1}{n_2}\right)^2 (1 - \alpha_1^2) \quad (3.13)$$

Since the alphas are directional cosines,

$$\alpha_1^2 + \alpha_2^2 + \alpha_3^2 = 1 \quad (3.14)$$

From Equation (3.12), squaring terms and collecting like terms produces

$$A^2 (\alpha_1^2 + \alpha_2^2 + \alpha_3^2) + 2AB \alpha_1 + B^2 = 1 \quad (3.15)$$

Using Equation (3.14), Equation (3.15) reduces to

$$2AB\alpha_1 + B^2 = 1 - A^2 \quad (3.16)$$

Substituting Equation (3.13) into (3.16) yields

$$1 - \left(\frac{n_1}{n_2}\right)^2 (1 - \alpha_1^2) = A^2 \alpha_1^2 + 1 - A^2$$

$$\left(\frac{n_1}{n_2}\right)^2 (\alpha_1^2 - 1) = A^2 (\alpha_1^2 - 1)$$

$$A = \frac{n_1}{n_2}$$

This then implies from Equation (3.12) that

$$\alpha_2' = \frac{n_1}{n_2} \alpha_2 \quad (3.17)$$

$$\alpha_3' = \frac{n_1}{n_2} \alpha_3 \quad (3.18)$$

Again, using the point-direction form of a line, the points P_5 and P_6 become respectively

$$x_5 = d_3 + w$$

$$y_5 = y_3 + \frac{\hat{v}_{52}}{\hat{v}_{51}} w$$

$$z_5 = z_3 + \frac{\hat{v}_{53}}{\hat{v}_{51}} w$$

and

$$x_6 = d_3 + w$$

$$y_6 = y_4 + \frac{\hat{v}_{62}}{\hat{v}_{61}} w$$

$$z_6 = z_4 + \frac{\hat{v}_{63}}{\hat{v}_{61}} w$$

Window to Tunnel

From Equations (3.11), (3.17), and (3.18), the rays which traverse the wind tunnel can be calculated from the incident rays to the window using the ratio of the index of refraction outside the tunnel over the index of refraction inside the tunnel. Knowing P_5 , P_6 , \hat{V}_7 , and \hat{V}_8 , use of the point-direction form of a line to solve for the location of the probe volume is possible. However, should the lines be skew this approach will provide erroneous results. What is needed is an approach to determining the location of the points which will be at the minimum distance of two skew lines.

The approach taken is a minimization problem involving the point-direction form of a line, the parametric representation of a line, and the squared distance between the points. The point-direction form of two lines, and in this case using the two laser beams which traverse the wind tunnel, are

$$\frac{x'-x_5}{\hat{V}_{71}} = \frac{y'-y_5}{\hat{V}_{72}} = \frac{z'-z_5}{\hat{V}_{73}} = r \quad (3.19)$$

and

$$\frac{x-x_6}{\hat{V}_{81}} = \frac{y-y_6}{\hat{V}_{82}} = \frac{z-z_6}{\hat{V}_{83}} = t \quad (3.20)$$

where r and t are the parameters of the two lines. From Equations (3.19) and (3.20), the parametric representation of the lines can be written as

$$x' = x_5 + r\hat{V}_{71} \quad (3.21a)$$

$$y' = y_5 + r\hat{V}_{72} \quad (3.21b)$$

$$z' = z_5 + r\hat{V}_{73} \quad (3.21c)$$

and

$$x = x_6 + t\hat{v}_{81} \quad (3.22a)$$

$$y = y_6 + t\hat{v}_{82} \quad (3.22b)$$

$$z = z_6 + t\hat{v}_{83} \quad (3.22c)$$

and the squared distance is

$$d^2 = (x-x')^2 + (y-y')^2 + (z-z')^2 \quad (3.23)$$

Substituting Equations (3.21) and (3.22) into (3.23), d is now represented as a function of r and t as

$$\begin{aligned} d^2(r,t) = & (x_6 + t\hat{v}_{81} - x_5 - r\hat{v}_{71})^2 + (y_6 + t\hat{v}_{82} - y_5 - r\hat{v}_{72})^2 \\ & + (z_6 + t\hat{v}_{83} - z_5 - r\hat{v}_{73})^2 \end{aligned} \quad (3.24)$$

It can be easily shown that the values of t and r which minimize $d(r,t)$ are

$$t = \frac{be - ad}{bc - a^2} \quad (3.24)$$

and

$$r = \frac{ae - cd}{bc - a^2} \quad (3.25)$$

where

$$a = \hat{v}_{71}\hat{v}_{81} + \hat{v}_{72}\hat{v}_{82} + \hat{v}_{73}\hat{v}_{83}$$

$$b = \hat{v}_{71}^2 + \hat{v}_{72}^2 + \hat{v}_{73}^2$$

$$c = \hat{v}_{81}^2 + \hat{v}_{82}^2 + \hat{v}_{83}^2$$

$$d = - [(x_6 - x_5)\hat{v}_{71} + (y_6 - y_5)\hat{v}_{72} + (z_6 - z_5)\hat{v}_{73}]$$

and

$$e = - [(x_6 - x_5)\hat{V}_{81} + (y_6 - y_5)\hat{V}_{82} + (z_6 - z_5)\hat{V}_{83}]$$

Now that r and t are known, these values can be used in Equations (3.21) and (3.22) to determine P_7 if the lines intersect or the points on \vec{V}_7 and \vec{V}_8 where the distance between the lines is a minimum. In the latter case, the midpoint between the minimum distance points provides a convenient means of locating the probe volume, provided there is overlap of the rays to create a useable probe volume. Remember, lines have length but no width, whereas the laser beams have finite width and may overlap.

Coordinate Transformation

Now that the location of the probe volume is known in the mirror RCCS, it is necessary to transform the location into values in the tunnel RCCS. The relationship between the mirror and tunnel RCCS is illustrated in Figure 2.1a. A matrix will be used to perform a simple change of basis where the new set of unit vectors is related to the old by a simple rotation about one of the coordinate axes. In this case, a rotation about the z-axis uses the matrix

$$\begin{bmatrix} \cos\gamma & \sin\gamma & 0 \\ -\sin\gamma & \cos\gamma & 0 \\ 0 & 0 & 1 \end{bmatrix}$$

The rotation from the mirror RCCS to the tunnel RCCS is through the angle $\gamma = -90$. This results in the rotation matrix

$$\begin{bmatrix} 0 & -1 & 0 \\ 1 & 0 & 0 \\ 0 & 0 & 1 \end{bmatrix} \tag{3.26}$$

The transpose of the above matrix can be used to transform any point

from the tunnel to the mirror RCCS.

Up to this point, we have determined the intersection location in the tunnel of the two converging rays which originated in the x-y plane and the probe volume they create. This was accomplished by starting from the lens, which causes the convergence of the rays, finding the points on the mirror and surfaces of the window, and their respective resultant vectors due to reflection or refraction. But this only determines the first probe volume which will be used to determine the x-component of the velocity. To measure the y-component of velocity, we need to determine the method for calculating the location and orientation of the second probe volume. This second probe volume is created by the two converging rays which originate in the y-z plane.

IV. Y-Z Plane Analysis

This section deals with the handling of the y-z plane as it differs from the x-y plane in determining the location and orientation of the second probe volume which is used to measure the y-component of velocity. Once the differences are discussed, an example will be presented which illustrates the working of the analytical procedures developed thus far.

As seen in Figure 4.1, the first difference lies in determining the equations of the vectors \vec{V}_1 and \vec{V}_2 , and their corresponding line equations. Vectors \vec{V}_1 and \vec{V}_2 , in the y-z plane have the following free space equations

$$\vec{V}_1 = d_1 \hat{j} - (s/2) \hat{k}$$

$$\vec{V}_2 = d_1 \hat{j} + (s/2) \hat{k}$$

Also from Figure 4.1, the angle μ is needed in determining the points on the mirror \vec{V}_1 and \vec{V}_2 fall. μ is $90-\epsilon$ or using the trigonometry of the right triangle,

$$\tan \mu = \frac{s}{2f} \quad (4.1)$$

Now, the vectors \vec{V}_1 and \vec{V}_2 can be represented by the following line equations

$$\vec{V}_1: (z-s/2) = -(y+d_1) \tan \mu \quad (4.2)$$

$$\vec{V}_2: (z+s/2) = (y+d_1) \tan \mu \quad (4.3)$$

Rather than seeing the mirror as a line, the \vec{V}_1 and \vec{V}_2 vectors in the y-z plane see the mirror as a plane. As stated before, when the mirror

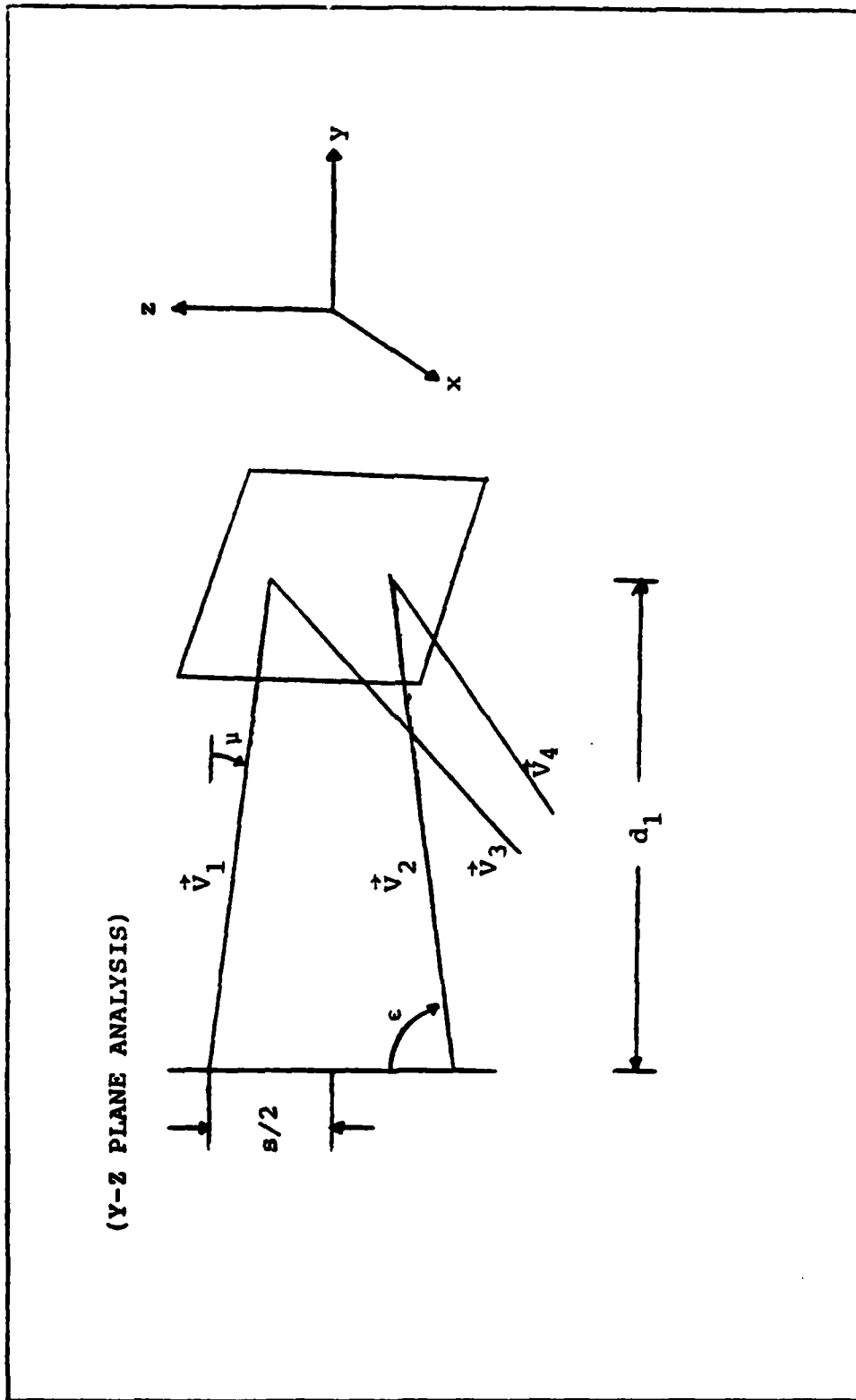

Figure 4.1. Geometry and designation of laser beams originating in y-z plane.

is rotated through ϕ degrees, the z components of the vectors and points are determined. For a rotation through some angle ϕ , as θ changes, so does the slope of the line seen by \vec{V}_1 and \vec{V}_2 in the y-z plane. Therefore, the mirror is represented as a plane using the normal to the mirror and the dot product between the normal and an arbitrary point on the plane. Given an arbitrary point on the plane

$$P = xi + yj + zk \quad (4.4)$$

and the normal to the mirror

$$\hat{n}_m = \cos\phi \cos\delta \hat{i} + \cos\phi \sin\delta \hat{j} + \sin\phi \hat{k}$$

the dot product is zero since the point and the normal are orthogonal.

This represents the general equation of a plane (Ref 8:540)

$$P \cdot \hat{n} = x \cos\phi \cos\delta + y \cos\phi \sin\delta + z \sin\phi = 0 \quad (4.5)$$

Using the fact that $x = 0$, since the points of intersection lie in the y-z plane, and substituting Equation (4.2) into (4.5), the y-coordinate of P_1 can be determined as follows

$$y \cos\phi \sin\delta + (s/2 - y \tan\mu - d_1 \tan\mu) \sin\phi = 0$$

$$y(\cos\phi \sin\delta - \tan\mu \sin\phi) = (d_1 \tan\mu - s/2) \sin\phi$$

Therefore, after collecting like terms

$$\begin{aligned} y_1 &= \frac{(d_1 \tan\mu - s/2) \sin\phi}{\cos\phi \sin\delta - \tan\mu \sin\phi} \\ &= \frac{s(d_1/f - 1) \sin\phi}{2(\cos\phi \sin\delta - (s/2f) \sin\phi)} \end{aligned}$$

and using Equation (4.1), y_1 becomes

$$y_1 = \frac{s(d_1 - f) \sin\phi}{2f \cos\phi \sin\delta - s \sin\phi} \quad (4.6a)$$

Substituting this value into Equation (4.2) and solving for z_1 , we get

$$z_1 = \frac{s(f-y_1-d_1)}{2f} \quad (4.6b)$$

Similarly, substituting Equation (4.3) into (4.5), y_2 becomes

$$y_2 = \frac{s(f-d_1) \sin \phi}{2f \cos \phi \sin \delta + s \sin \phi} \quad (4.7a)$$

Substituting this value into Equation (4.3) we get

$$z_2 = \frac{s(y_2+d_1-f)}{2f} \quad (4.7b)$$

We have now determined the necessary information to trace the laser beams from the lens to the mirror. To get from the mirror to the location of the resultant probe volume, the steps in the previous chapter from mirror to coordinate transformation can be used without modification.

Now that the numerical method to determine the location of both probe volumes is complete, an example of their use would complete the preceding derivation. Chosen for this example is an orientation of the mirror which causes the lines to be skew. Although this runs counter to intuition, this choice of orientation provides a good example of the mathematics and physics of the situation.

As an example of the analysis so far, choose a pair of angles θ and ϕ such that the two sets of rays will go through the six-inch-diameter tunnel access window. Given that $d_3 = 2.5$ in, from the geometry of the setup, the angles, in degrees, $(\theta, \phi) = (34, -22)$ will allow the rays to enter the tunnel. From Table I, we can trace the rays from the lens to the tunnel by calculating points and resultant vectors along

TABLE I
Results of Ray Trace for $(\theta, \phi) = (34, -22)$

| | X-Y PLANE | Y-Z PLANE |
|-------------------|--------------------------------|--------------------------------|
| V ₁ | .5, 30, 0 | 0, 30, -.5 |
| V ₂ | -.5, 30, 0 | 0, 30, .5 |
| P ₁ | -.45301, -.30556, 0 | 0, -.22008, .45158 |
| P ₂ | .44294, .29876, 0 | 0, -.21653, -.44431 |
| V ₃ | .80467, -.16840, -.56934 | .79049, -.17209, -.58781 |
| V ₄ | .78926, -.19497, -.58229 | .80343, -.19128, -.56383 |
| dist* | ϕ | ϕ |
| P ₃ | 2.5, -.92356, -2.0894 | 2.5, -.76432, -1.4074 |
| P ₄ | 2.5, -.20938, -1.5176 | 2.5, -.37866, -2.1987 |
| V ₅ | .84691, -.15082, -.50991 | .83613, -.15412, -.52644 |
| V ₆ | .83519, -.17461, -.52150 | .84597, -.17131, -.50497 |
| dist* | .04328 | .04288 |
| P ₅ | 2.875, -.99034, -2.3152 | 2.875, -.83344, -1.6435 |
| P ₆ | 2.875, -.28778, -1.7518 | 2.875, -.45460, -2.4226 |
| V ₇ | .80467, -.16840, -.56934 | .79049, -.17209, -.58781 |
| V ₈ | .78926, -.19497, -.58229 | .80343, -.19128, -.56383 |
| P ₇ ** | 21.49711, -4.887731, -15.49101 | 21.49151, -4.886469, -15.48696 |
| dist* | .000669 | .000669 |

Note: All values in table are in inches. Angles are measured in degrees.

* distance between skew lines using previous pairs of points and vectors

** midpoint location

$d_1 = 3.125$ $f = 30$ $w = 0.375$ $d_3 = 2.5$ $s = 1.0$

the way. The interesting aspect of this orientation is that skewness occurs after the pair of rays leaves the first surface of the window and the distance between the lines decreases after the second surface. This is due to the index of refraction inside the tunnel being equal to that outside the tunnel which tries to restore the rays, through refraction, to their original state but fails to do so.

To get a representation of results for the various parts of the tunnel access window, pairs of angles (θ, ϕ) which satisfy the requirement to enter the tunnel through the six inch diameter window and their locations on the window (Figure 4.2) are listed in Table II.

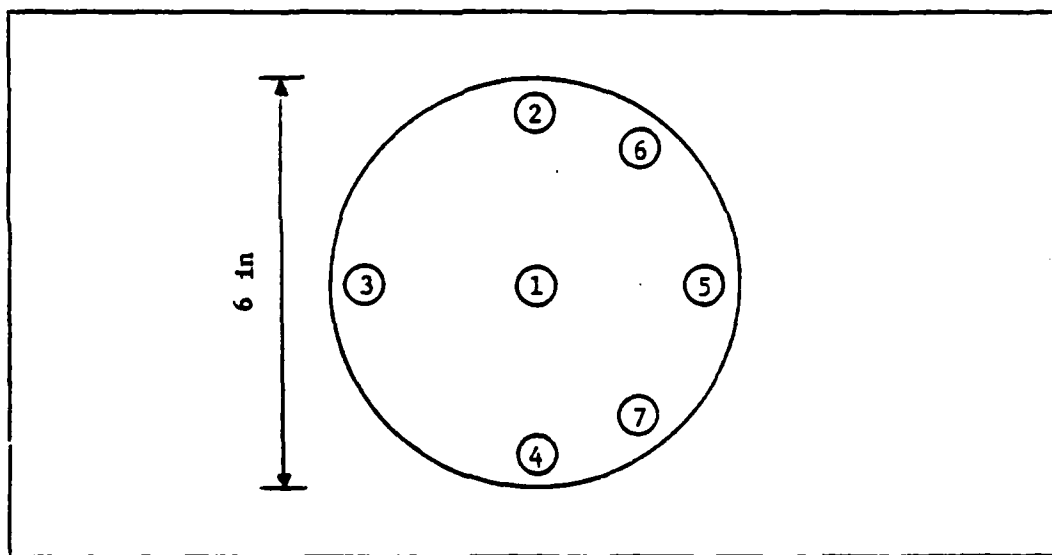

Figure 4.2. Location of rays in Table II which fall on the tunnel access window.

The values are seen to be symmetric about $\phi = 0$ and also $\theta = 45$. Values in Table II are listed in inches and those in parenthesis are in millimeters.

So far, this analysis has traced two pairs of laser beams through a lens, reflected off a mirror, refracted through a window, and ending

TABLE II

Results for Various Values of θ and ϕ

| (θ, ϕ) | Point Set Number | X-Y PLANE | | Y-Z PLANE | | Distance Between Probe Volumes |
|------------------|------------------|-----------------------|----------------------|-----------------------|----------------------|--------------------------------|
| | | Location (Midpoint) | Separation of Lines | Location (Midpoint) | Separation of Lines | |
| 45,0 | 1 | 26.914,0,0 | ϕ | 26.914,0,0 | ϕ | ϕ |
| 45,46 | 2 | 13.118,13.9451,19.045 | .003396 (.100641) | 13.15,13.979,19.09 | .0033967 (.10072) | .064559 (1.640) |
| 68,0 | 3 | 18.292,19.388,0 | ϕ | 18.74,19.332,0 | ϕ | .0769159 (1.9537) |
| 45,-46 | 4 | 13.118,13.945,-19.045 | .003396 (.100641) | 13.15,13.979,-19.09 | .0033967 (.10072) | .064559 (1.640) |
| 22,0 | 5 | 18.792,-19.388,0 | ϕ | 18.74,-19.332,0 | ϕ | .0769159 (1.9537) |
| 34,22 | 6 | 21.497,-4.888,15.491 | .0006688 (.01699) | 21.492,-4.886,15.487 | .000668 (.01699) | .0070253 (.17844) |
| 34,-22 | 7 | 21.497,-4.888,-15.491 | .0006688 (.01699) | 21.492,-4.886,-15.487 | .000668 (.01699) | .0070253 (.17844) |

$d_1 = 3.125$ $f = 30$ $w = .375$

$d_3 = 2.5$ $s = 1.0$

Note: Values in table are in inches. Values in parentheses are measured in millimeters.
Angles are measured in degrees.

up in the tunnel by converging, or nearly converging, to form a horizontally and vertically oriented probe volume. If the probe volumes are useable, the velocities they measure are in the coordinate system formed by the geometry of the probe volume. Another rotation matrix is needed then to complete this portion of the analysis.

V. Velocity Transformation

At this point, the location of the probe volume has been analytically determined and now the orientation of the probe volume is needed because the measured velocity component is perpendicular to the bisector of the angle between the two beams and in the plane of the two beams. Once a velocity is measured using the horizontal and vertical probe volumes, that velocity's components are in the coordinate system of the respective probe volume's RCCS. The probe volume RCCS can be calculated based upon Figure 5.1.

The probe volume is formed by the intersection of vectors \vec{V}_7 and \vec{V}_8 which also forms the plane which bisects the probe volume. Therefore, crossing \vec{V}_8 into \vec{V}_7 results in a vector perpendicular to this plane and the probe volume. This vector then becomes the z-axis candidate for the probe volume coordinate system.

Since \hat{V}_7 and \hat{V}_8 are unit vectors, their sum forms a vector which bisects the probe volume angle and lies in the plane of the vectors (see Figure 5.2). This vector then becomes the y-axis candidate for the probe volume coordinate system.

The x-axis is the only axis remaining and the one necessary to measure the velocity since it will be perpendicular to the bisector of the probe volume angle and in the plane of the two beams. To form this axis, cross the candidate y-axis into the candidate z-axis.

The resulting equations are then

$$\vec{C}_z = \hat{V}_8 \times \hat{V}_7$$

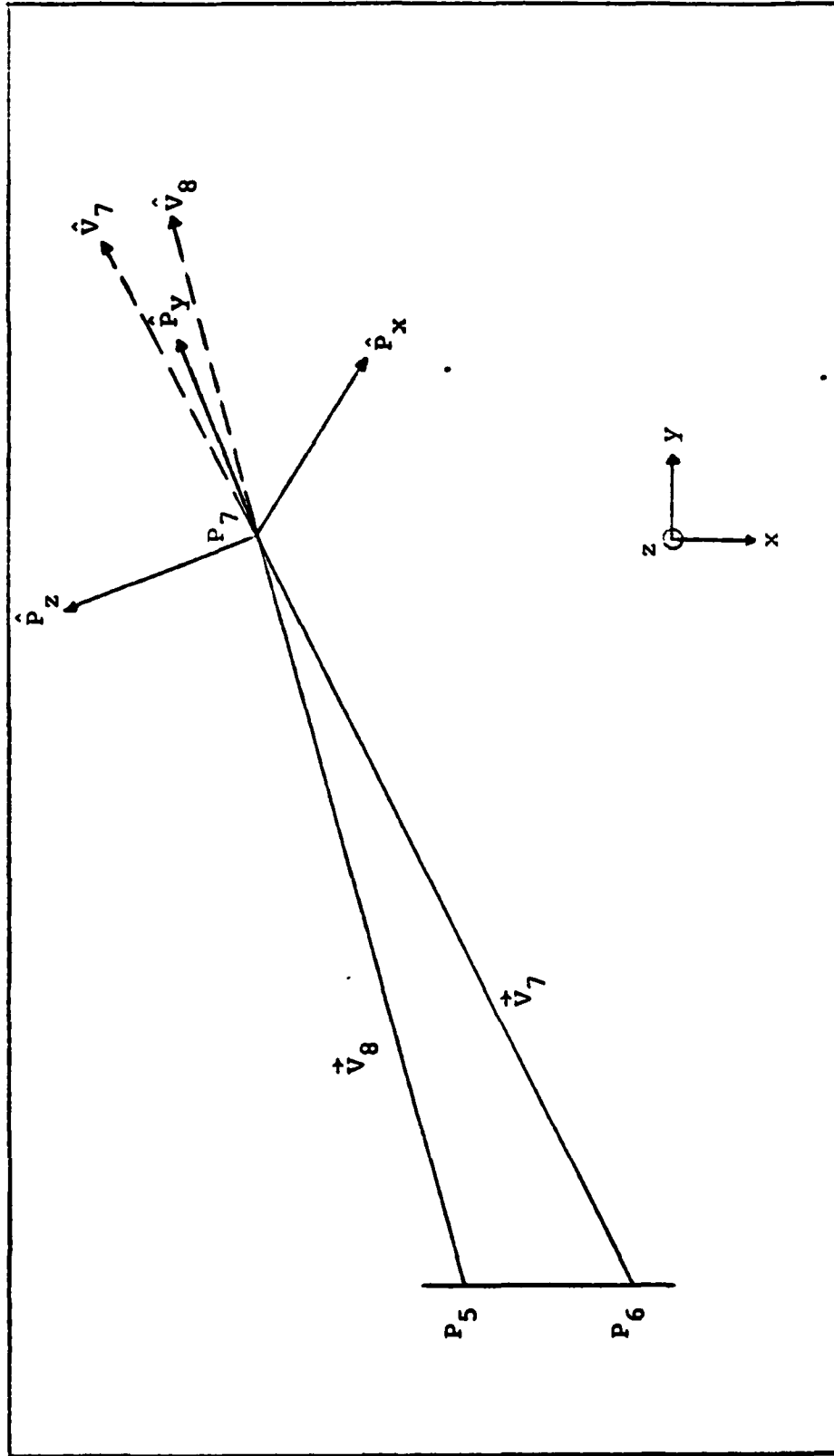

Figure 5.1. Orientation of probe volume.

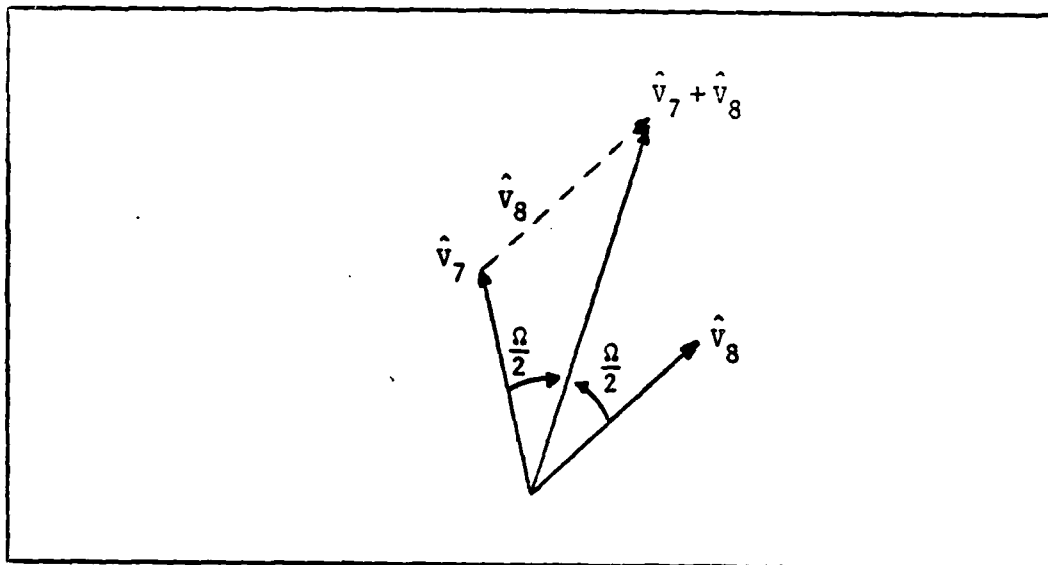

Figure 5.2. Vector addition of unit vectors.

$$\vec{C}_y = \hat{v}_7 + \hat{v}_8$$

$$\vec{C}_x = \vec{C}_y \times \vec{C}_z$$

Once \vec{C}_x , \vec{C}_y , and \vec{C}_z are normalized, they form an orthonormal basis which can be used as the coordinate system for the probe volume and measurement of the velocity component for that set of rays. The transpose of the C matrix

$$C = \begin{bmatrix} \hat{C}_x \\ \hat{C}_y \\ \hat{C}_z \end{bmatrix} = \begin{bmatrix} c_{11} & c_{12} & c_{13} \\ c_{21} & c_{22} & c_{23} \\ c_{31} & c_{32} & c_{33} \end{bmatrix}$$

is the transformation matrix which can be used for transforming the velocity measurements from the probe volume to the mirror coordinate system.

Caution should be exercised in relying on this matrix if the laser

beams are skew. The transformation matrix should provide the best method of transforming the velocity for this use.

VI. Convergence Criteria

This chapter will address the conditions necessary for convergence of each pair of laser beams for the LDV setup in Figure 1.1. This does not guarantee convergence of each pair at the same point, only of each pair. For the rays to converge, two theorems are stated and proved which provide the necessary and sufficient conditions for intersection of the laser beams after they pass through the tunnel access window. Once these theorems are proved, their results are then transformed from the conditions on the laser beams to conditions on the orientation of the mirror which will provide for the intersection of the laser beams.

In space, two lines generally have no point in common. For if l and l' are two lines with the equations

$$x = x(t) = x_1 + ta$$

$$x' = x'(\tau) = x_1' + \tau a'$$

and they have (at least) one common point, then there must be (at least) one pair of values t , such that

$$x(t) = x'(\tau).$$

To this vector equation, there corresponds a system of three linear equations for the two unknowns, which is generally not soluble. The conditions

$$a \times a' \neq 0$$

$$(x_1 - x_1') \cdot (a \times a') = 0 \tag{6.1}$$

are necessary and sufficient for the existence of a unique solution. That is, for two lines in space to have exactly one point in common (Ref 8:539).

Therefore, for the laser Doppler velocimeter (LDV) setup illustrated in Figure 1.1, we can state the following theorem

Theorem 1: If the movement through the angles θ and ϕ results in a pair

of rays lying in a plane formed by two of the mirror coordinate axes, then they will intersect in the tunnel.

Approach: Theorem 1 can be proved by inspection of two cases where the refracted laser beams lie in the x-y plane and in the y-z plane.

Case I: The rays lie in the x-y plane.

Given: (1) $\alpha_3 = \beta_3 = 0$,

(2) $x_5 = x_6$, and

(3) $z_5 = z_6 = 0$.

Approach: Substitute the given conditions into Equation (6.1) and solve.

Proof: Therefore

$$(P_5 - P_6) = (y_5 - y_6)j$$

and

$$\hat{V}_7 \times \hat{V}_8 = (\alpha_1 \beta_2 - \alpha_2 \beta_1) \hat{k}$$

which, when applied to the intersection criteria in Equation (6.1), results in

$$(P_5 - P_6) \cdot (\hat{V}_7 \times \hat{V}_8) = 0$$

and the rays are shown to intersect.

Case II: The rays lie in the y-z plane.

Given: (1) $\alpha_2 = \beta_2 = 0$,

(2) $x_5 = x_6 = 0$, and

(3) $y_5 - y_6 = 0$

Approach: Substitute the given conditions into Equation (6.1) and solve.

Proof: Therefore

$$(P_5 - P_6) = (z_5 - z_6)k$$

and

$$\hat{v}_7 \times \hat{v}_8 = (\alpha_3 \beta_1 - \alpha_1 \beta_3) \hat{j}$$

which, when applied to the intersection criteria in Equation (6.1),

results in

$$(P_5 - P_6) \cdot (\hat{v}_7 \times \hat{v}_8) = 0$$

and the rays are again shown to intersect.

So far, only intersection in a plane has been addressed and there is a myriad of angles θ and ϕ which the mirror can be oriented where the rays are not in a plane formed by two of the coordinate axes. The second theorem addresses the necessary and sufficient conditions for intersection of a pair of laser beams outside of a coordinate axes plane.

Theorem 2: Given an arbitrary set of distinct points P_1 and P_2 , the direction cosines $(\alpha_1, \alpha_2, \alpha_3)$ and $(\beta_1, \beta_2, \beta_3)$, and the property that these rays emanating from P_1 and P_2 intersect at a point, and given these rays pass through a window of width w , optically perfect and having parallel sides, the normal to the window being the x -axis of the P_1, P_2 coordinate system, and equal indices of refraction on either side of the window, then the refracted rays will intersect if and only if $\alpha_1 = \beta_1$.

For this theorem, a proof is given for each direction of the if and only if condition, i.e., if the refracted rays intersect then $\alpha_1 = \beta_1$, and if $\alpha_1 = \beta_1$ then the refracted rays intersect.

The following proof is for the condition that if the refracted rays intersect, then $\alpha_1 = \beta_1$ for any arbitrary points P_1 and P_2 on the mirror.

Given: (1) The rays intersect, and

(2) The indices of refraction inside and outside the tunnel are equal.

Approach: Use the given conditions in Equation (6.1) and solve for the conditions on the direction cosines which will cause the rays to

intersect.

Proof: From Figure 6.1, Equations (3.11), (3.17), (3.18), and setting

$$k = \frac{n_1}{n_2} \quad (6.2)$$

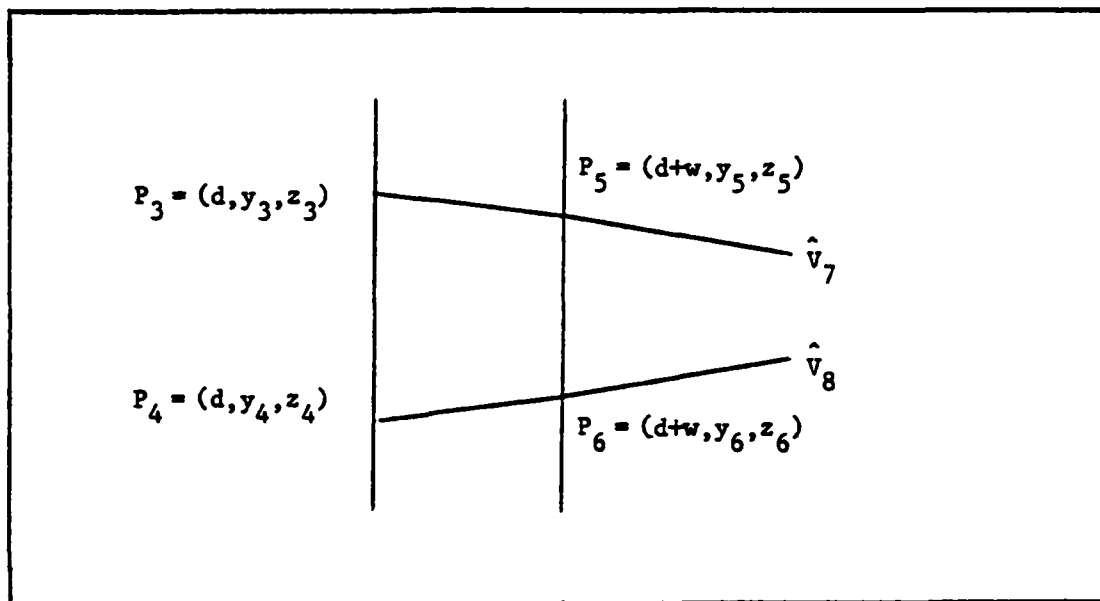

Figure 6.1 Designation of points and vectors for Convergence analysis.

we have

$$\alpha_1' = (1 - k^2 + k^2 \alpha_1^2)^{1/2} \quad (6.3a)$$

$$\alpha_2' = k \alpha_2 \quad (6.3b)$$

$$\alpha_3' = k \alpha_3 \quad (6.3c)$$

and

$$\beta_1' = (1 - k^2 + k^2 \beta_1^2)^{1/2} \quad (6.3d)$$

$$\beta_2' = k \beta_2 \quad (6.3e)$$

$$\beta_3' = k\beta_3 \quad (6.3f)$$

where $(\alpha_1', \alpha_2', \alpha_3')$ and $(\beta_1', \beta_2', \beta_3')$ are the direction cosines of the rays in the window after being refracted by the change in index of refraction.

Writing P_5 and P_6 in the point-direction form of a line,

$$P_5: \frac{w}{\alpha_1'} = \frac{y_5 - y_3}{\alpha_2'} = \frac{z_5 - z_3}{\alpha_3'} = t$$

$$P_6: \frac{w}{\beta_1'} = \frac{y_6 - y_4}{\beta_2'} = \frac{z_6 - z_4}{\beta_3'} = \tau$$

Therefore, using the parametric representation of a line, P_5 and P_6 are respectively

$$x_5 = d + w$$

$$y_5 = y_3 + kt\alpha_2$$

$$z_5 = z_3 + kt\alpha_3$$

and

$$x_6 = d + w$$

$$y_6 = y_4 + kt\beta_2$$

$$z_6 = z_4 + kt\beta_3$$

where

$$t = \frac{w}{(1 - k^2 + k^2 \alpha_1'^2)^{1/2}} \quad (6.4)$$

$$\tau = \frac{w}{(1 - k^2 + k^2 \beta_1'^2)^{1/2}} \quad (6.5)$$

Next, the lines $\overline{P_3 P_4}$ and $\overline{P_5 P_6}$ are to be found for eventual substitution

into the conditions for intersection given by Equation (6.1). $\overline{P_3P_4}$ can be written in component form as

$$i: d-d = 0$$

$$j: y_3 - y_4 = \Delta y$$

$$k: z_3 - z_4 = \Delta z$$

and $\overline{P_5P_6}$ has components

$$i: (d+w) - (d+w) = 0$$

$$j: y_5 - y_6 = y_3 - y_4 + k\tau\alpha_2 - k\tau\beta_2$$

$$k: z_5 - z_6 = z_3 - z_4 + k\tau\alpha_3 - k\tau\beta_3$$

Rewriting $\overline{P_5P_6}$ using the values for t and τ given in Equations (6.4), (6.5), and the components of $\overline{P_3P_4}$

$$i: 0 \tag{6.6a}$$

$$j: \Delta y + \frac{wk\alpha_2}{(1-k^2+k^2\alpha_1^2)^{1/2}} - \frac{wk\beta_2}{(1-k^2+k^2\beta_1^2)^{1/2}} \tag{6.6b}$$

$$k: \Delta z + \frac{wk\alpha_3}{(1-k^2+k^2\alpha_1^2)^{1/2}} - \frac{wk\beta_3}{(1-k^2+k^2\beta_1^2)^{1/2}} \tag{6.6c}$$

Let

$$A = (1-k^2+k^2\alpha_1^2)^{1/2} \tag{6.7}$$

and

$$B = (1-k^2+k^2\beta_1^2)^{1/2} \tag{6.8}$$

It is given that $\overline{P_3P_4} \cdot (\hat{V}_3 \times \hat{V}_4) = 0$, where $\hat{V}_3 \times \hat{V}_4$ is

$$i: \alpha_2\beta_3 - \alpha_3\beta_2 \tag{6.9a}$$

$$j: \alpha_3\beta_1 - \alpha_1\beta_3 \tag{6.9b}$$

$$k: \alpha_1 \beta_2 - \alpha_2 \beta_1 \quad (6.9c)$$

Therefore, $\overline{P_3 P_4} \cdot (\hat{V}_3 \times \hat{V}_4)$ becomes

$$\Delta y (\alpha_3 \beta_1 - \alpha_1 \beta_3) + \Delta z (\alpha_1 \beta_2 - \alpha_2 \beta_1) = 0 \quad (6.10)$$

The conditions on $\overline{P_5 P_6} \cdot (\hat{V}_7 \times \hat{V}_8)$ which will assure intersection of \vec{V}_7 and \vec{V}_8 as they traverse the tunnel are required. Because the indices of refraction are the same for each side of the tunnel, $\hat{V}_7 = \hat{V}_3$, $\hat{V}_8 = \hat{V}_4$, and the components of $\hat{V}_7 \times \hat{V}_8$ are the same as in Equation (6.9). Substituting Equations (6.6), (6.7) and (6.8) into (6.1) results in

$$\begin{aligned} & \left[\Delta y + \frac{wk\alpha_2}{A} - \frac{wk\beta_2}{B} \right] (\alpha_3 \beta_1 - \alpha_1 \beta_3) \\ & + \left[\Delta z + \frac{wk\alpha_3}{A} - \frac{wk\beta_3}{B} \right] (\alpha_1 \beta_2 - \alpha_2 \beta_1) = 0 \end{aligned}$$

Rearranging the above produces

$$\begin{aligned} & [\Delta y (\alpha_3 \beta_1 - \alpha_1 \beta_3) + \Delta z (\alpha_1 \beta_2 - \alpha_2 \beta_1)] \\ & + wk \left[\frac{\alpha_2}{A} - \frac{\beta_2}{B} \right] (\alpha_3 \beta_1 - \alpha_1 \beta_3) \\ & + wk \left[\frac{\alpha_3}{A} - \frac{\beta_3}{B} \right] (\alpha_1 \beta_2 - \alpha_2 \beta_1) = 0 \quad (6.11) \end{aligned}$$

From Equation (6.10), the first term in Equation (6.11) is zero. Then dividing out wk from the second and third terms in Equation (6.11) results in

$$\left[\frac{\alpha_2}{A} - \frac{\beta_2}{B} \right] (\alpha_3 \beta_1 - \alpha_1 \beta_3) + \left[\frac{\alpha_3}{A} - \frac{\beta_3}{B} \right] (\alpha_1 \beta_2 - \alpha_2 \beta_1) = 0$$

Multiplying out and collecting like terms, the above equation becomes

$$\alpha_1 B (\alpha_3 \beta_2 - \alpha_2 \beta_3) = \beta_1 A (\alpha_3 \beta_2 - \alpha_2 \beta_3)$$

At this point, the $(\alpha_3\beta_2 - \alpha_2\beta_3)$ term may be eliminated by dividing it out of both sides of the equation, provided it is not zero. However, if the term is equal to zero, Theorem 1 applies, the lines intersect, and there is no need to divide the term out. If $(\alpha_3\beta_2 - \alpha_2\beta_3) \neq 0$, then it is divided out to determine the conditions for intersection. After dividing out the term, the equation reduces to

$$\alpha_1 B = \beta_1 A$$

Substituting Equations (6.7), (6.8) into the above and squaring both sides produces

$$\alpha_1^2 - k^2 \alpha_1^2 + \alpha_1^2 \beta_1^2 k^2 = \beta_1^2 - k^2 \beta_1^2 + \alpha_1^2 \beta_1^2 k^2$$

$$\alpha_1^2 - k^2 \alpha_1^2 = \beta_1^2 - k^2 \beta_1^2$$

$$\alpha_1^2 (1 - k^2) = \beta_1^2 (1 - k^2)$$

Again, $k = 1$ implies that $n_1 = n_2$ in Equation (6.2) and the lines intersect. If $k \neq 1$, then the necessary and sufficient condition for intersection is $\alpha_1 = \beta_1$ since the x-coordinate of both vectors in the mirror coordinate system will always be positive.

The following proof is for the condition that if $\alpha_1 = \beta_1$, then the refracted rays intersect for any arbitrary points P_1 and P_2 on the mirror.

Given: (1) $\alpha_1 = \beta_1$,

(2) Equal indices of refraction on both sides of the window, and

(3) \vec{V}_3 and \vec{V}_4 would intersect if the window was not in the path of the rays.

Approach: Starting with the points on the window (LDV side) where the

laser beams fall and using the parametric representation of a line, show that the beams which emanate from the last points on the window and traverse the tunnel, intersect based on the above given conditions.

Proof: The points on the window (tunnel side) can be written in parametric form based on the window (LDV side) points and the refracted vectors. To simplify the algebra, Equations (6.3) and (6.7) are used.

$$P_{51} = P_{31} + p\alpha_1' = d + pA$$

$$P_{52} = P_{32} + p\alpha_2' = P_{32} + pk\alpha_2$$

$$P_{53} = P_{33} + p\alpha_3' = P_{33} + pk\alpha_3$$

and

$$P_{61} = P_{41} + \pi\beta_1' = d + \pi A$$

$$P_{62} = P_{42} + \pi\beta_2' = P_{42} + \pi k\beta_2$$

$$P_{63} = P_{43} + \pi\beta_3' = P_{43} + \pi k\beta_3$$

These points also lie on the window where $P_{51} = P_{61} = d+w$, which implies that

$$d + pA = d + w$$

$$d + \pi A = d + w$$

or $p = \pi$.

From the given conditions, $(P_3 - P_4) \cdot (\hat{V}_3 \times \hat{V}_4) = 0$, or

$$\alpha_1(y_3 - y_4)(\alpha_3 - \beta_3) + \alpha_1(z_3 - z_4)(\beta_2 - \alpha_2) = 0 \quad (6.12)$$

Using the above equations for P_5 , P_6 , and letting $pk = Q$, it must be determined if $(P_5 - P_6) \cdot (\hat{V}_7 \times \hat{V}_8) = 0$. The first step is to evaluate the components of $(P_5 - P_6)$ which are

i: 0

j: $y_3 - y_4 + Q(\alpha_2 - \beta_2)$

k: $z_3 - z_4 + Q(\alpha_3 - \beta_3)$

applying the above and Equation (6.9) to Equation (6.1) results in

$$\begin{aligned} (P_5 - P_6) \cdot (\hat{V}_7 \times \hat{V}_8) &= \alpha_1(\alpha_3 - \beta_3)(y_3 - y_4) + \alpha_1(\alpha_3 - \beta_3)Q(\alpha_2 - \beta_2) \\ &+ \alpha_1(\beta_2 - \alpha_2)(z_3 - z_4) + \alpha_1(\beta_2 - \alpha_2)Q(\alpha_3 - \beta_3) \end{aligned}$$

Rearranging, the above equation becomes

$$\begin{aligned} &= [\alpha_1(y_3 - y_4)(\alpha_3 - \beta_3) + \alpha_1(z_3 - z_4)(\beta_2 - \alpha_2)] \\ &+ \alpha_1(\alpha_3 - \beta_3)(\alpha_2 - \beta_2)Q - \alpha_1(\alpha_3 - \beta_3)(\alpha_2 - \beta_2)Q \end{aligned} \quad (6.13)$$

The first term in Equation (6.13) is zero based on Equation (6.12).

The remaining portion of the equation is zero because of the difference in equal terms. Therefore, $(P_5 - P_6) \cdot (\hat{V}_7 \times \hat{V}_8) = 0$ which means that \vec{V}_7 and \vec{V}_8 intersect as defined by the stated conditions for intersection.

Now that the necessary and sufficient conditions for intersection have been established, it is necessary to find the conditions on θ and ϕ which provide intersection. The following analysis is based on the AEDC proposed LDV setup where the two sets of laser beams originate in the x-y and y-z planes, Figures 6.2 and 6.3.

The first case to be examined is for the rays which originate in the y-z plane. The given conditions are $\alpha_1 = \beta_1$ (i.e., the lines intersect), $n_1 = n_3$, and $x_5 = x_6$. Suppose the point of intersection is $P_7 = (x_7, y_7, z_7)$. By definition

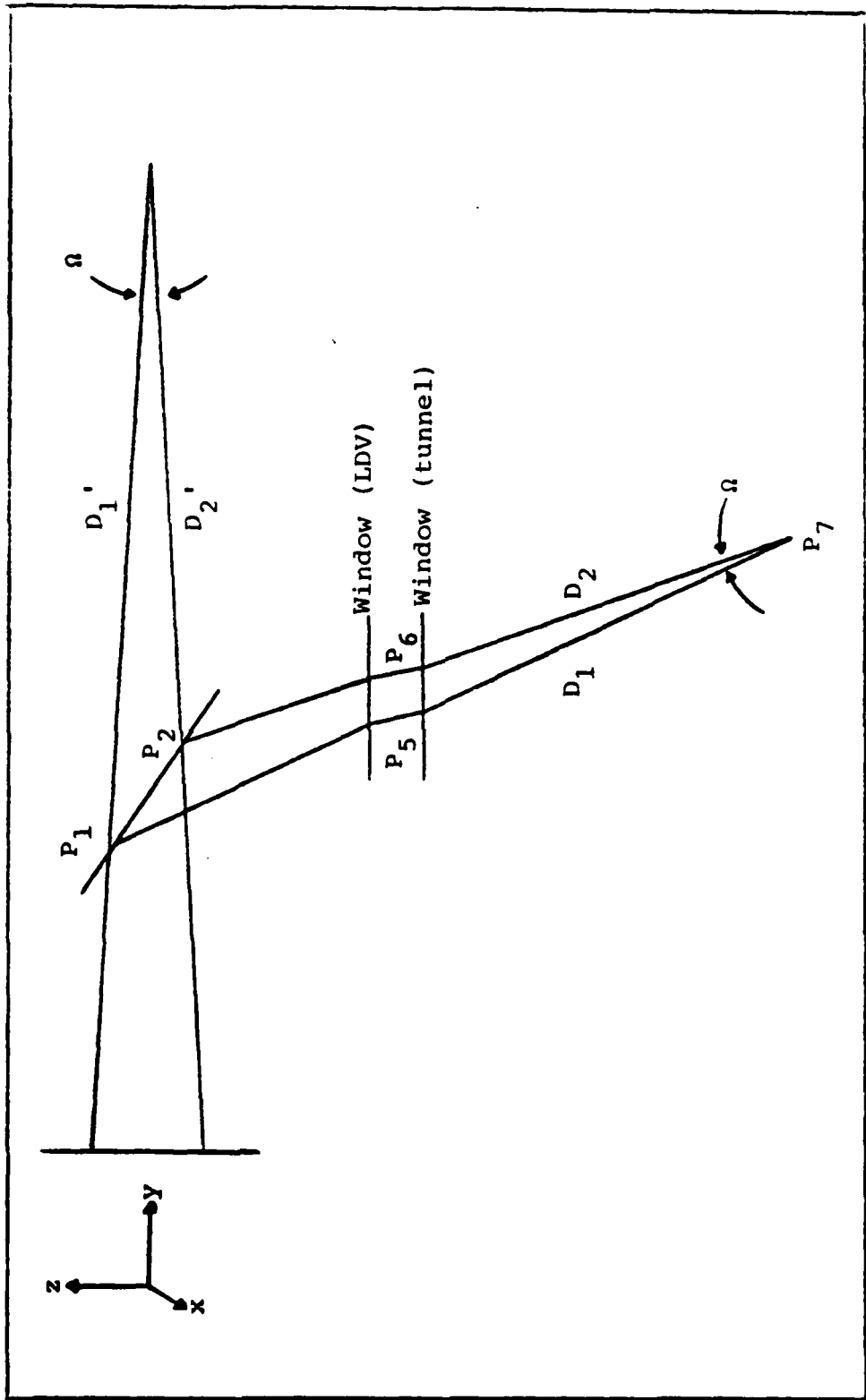

Figure 6.2. Illustration of LDV use.

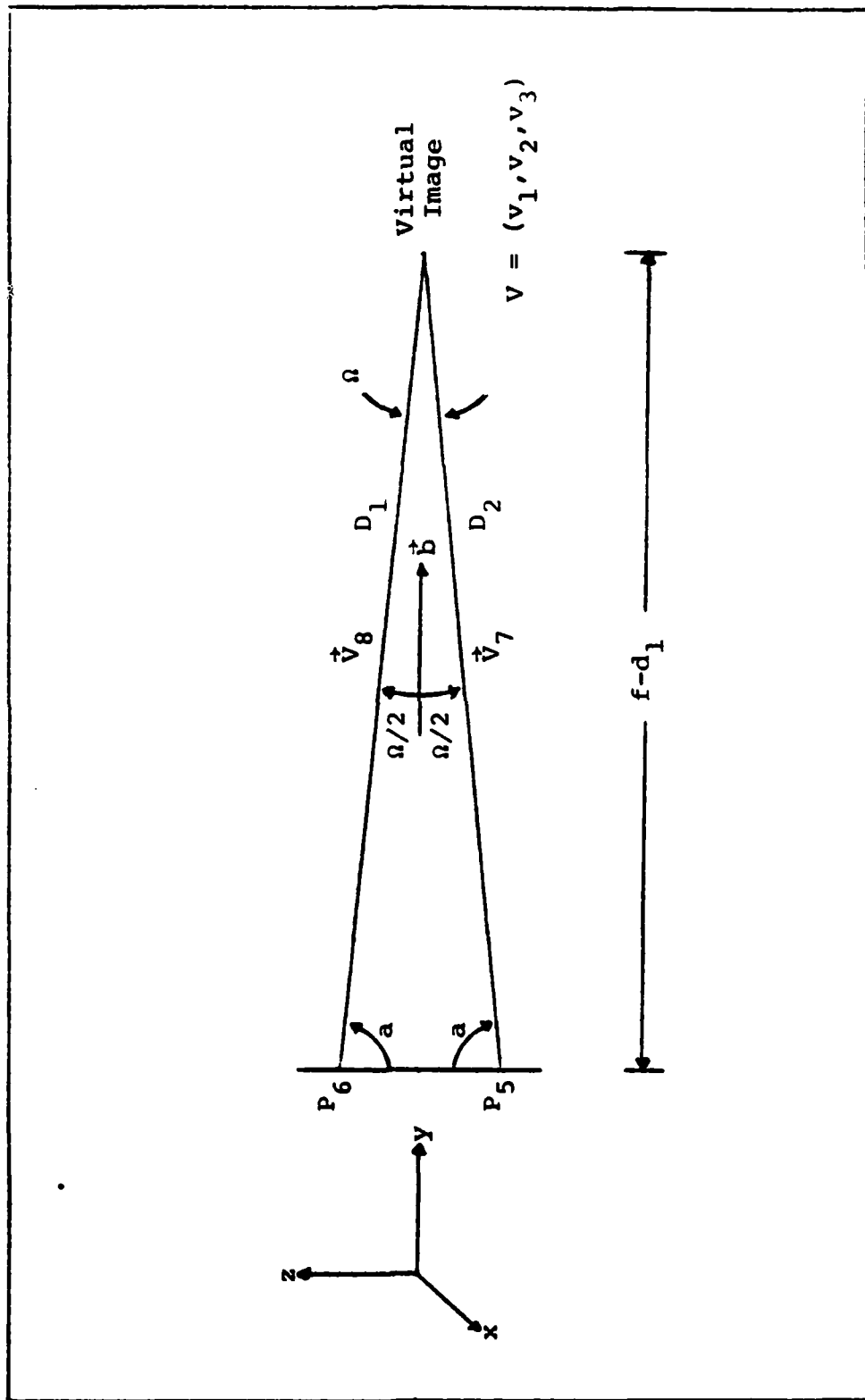

Figure 6.3. Geometry of convergence criteria.

$$\alpha_1 = \frac{x_7 - x_5}{D_1}$$

and

$$\beta_1 = \frac{x_7 - x_6}{D_2}$$

where

$$D_1 = [(x_7 - x_5)^2 + (y_7 - y_5)^2 + (z_7 - z_5)^2]^{1/2}$$

$$D_2 = [(x_7 - x_6)^2 + (y_7 - y_6)^2 + (z_7 - z_6)^2]^{1/2}$$

Since $\alpha_1 = \beta_1$ and $x_5 = x_6$, the above equations result in $D_1 = D_2$. That is the distance from the points P_5 and P_6 to P_7 are equal. From Figure 6.1, $P_5P_6P_7$ form an isosceles triangle. Hence, the angles opposite the equal sides are equal (Ref 11:79). This means

$$\hat{v}_7 \cdot \hat{k} = \hat{v}_8 \cdot \hat{k}$$

or

$$\alpha_3 = -\beta_3$$

By geometry of the LDV setup, the triangle's base lies parallel to the z-axis. Also, the lines intersect which means the z-component of one vector must be negative and then $\alpha_2 = \beta_2$. Since \hat{v}_7 and \hat{v}_8 are unit vectors, and therefore have equal magnitudes, $\hat{v}_7 + \hat{v}_8$ bisects the angle between them (i.e., they bisect the probe volume angle). Let \vec{b} be the bisecting vector, which is the result of the addition of \hat{v}_7 and \hat{v}_8 , and has the following equation

$$\vec{b} = 2\alpha_1 \hat{i} + 2\alpha_2 \hat{j}$$

Since $\hat{v}_7 = \alpha_1 \hat{i} + \alpha_2 \hat{j} + \alpha_3 \hat{k}$ and $\hat{v}_8 = \alpha_1 \hat{i} + \beta_2 \hat{j} - \beta_3 \hat{k}$. If \vec{b} is dotted

with each of the coordinate axes, this results in

$$\vec{b} \cdot \hat{i} = \cos \epsilon_1 = 2\alpha_1 / |\vec{b}|$$

$$\vec{b} \cdot \hat{j} = \cos \epsilon_2 = 2\alpha_2 / |\vec{b}|$$

$$\vec{b} \cdot \hat{k} = \cos \epsilon_3 = 0$$

which indicates that \vec{b} must be perpendicular to the z-axis and is free to move in the x-y plane. Therefore, for intersection (i.e., when $\alpha_1 = \beta_1$), $\phi = 0$, $z_7 = 0$, and the mirror is free to move through the angle θ .

A similar argument can be given for the rays originating in the x-y plane with the result that

$$\alpha_2 = -\beta_2$$

$$\alpha_3 = \beta_3$$

since $\hat{v}_7 = \alpha_1 \hat{i} + \alpha_2 \hat{j} + \alpha_3 \hat{k}$ and $\hat{v}_8 = \alpha_1 \hat{i} - \beta_2 \hat{j} + \beta_3 \hat{k}$. Therefore, the vector \vec{b} becomes

$$\vec{b} = 2\alpha_1 \hat{i} + 2\alpha_3 \hat{k}$$

Dotting \vec{b} with each of the coordinate axes results in

$$\vec{b} \cdot \hat{i} = \cos i_1 = 2\alpha_1 / |\vec{b}|$$

$$\vec{b} \cdot \hat{j} = \cos i_2 = 0$$

$$\vec{b} \cdot \hat{k} = \cos i_3 = 2\alpha_3 / |\vec{b}|$$

This indicates that \vec{b} must be perpendicular to the y-axis and is free to move in the x-z plane. Therefore, for intersection (i.e., when $\alpha_1 = \beta_1$) the relationship between θ and ϕ must be such to maintain $y_7 = 0$ and $\alpha_1 = \beta_1$.

The relationship between θ and ϕ to get $y_7 = 0$ is not as simple as setting $\phi = 0$ to get $z_7 = 0$. For the mirror to reflect the laser beams which originate in the y - z plane into the x - z plane (i.e., $y_7 = 0$), set the equation for the y value (without window) equal to zero

$$y = \sin^2 \theta - \cos^2 \theta \cos 2\phi = 0$$

The results can then be illustrated in two ways. The first is to solve the equation for ϕ in terms of θ

$$\phi = \cos^{-1} [\sqrt{2} \cos \theta]$$

The result can be seen in Figure 6.4. The other method is to set a value for θ , change ϕ and graph ϕ versus y as in Figure 6.5. Both of these figures represents the relationship between θ and ϕ to have $y_7 = 0$ and the laser beams converge.

In summary, the first theorem guarantees intersection when the rays lie in a plane formed by the coordinate axes of the mirror RCCS and the second theorem when the rays do not lie in a plane formed by the coordinate axes of the mirror RCCS. Also, the conditions for the orientation of the AEDC proposed LDV setup have been provided which will produce the above results.

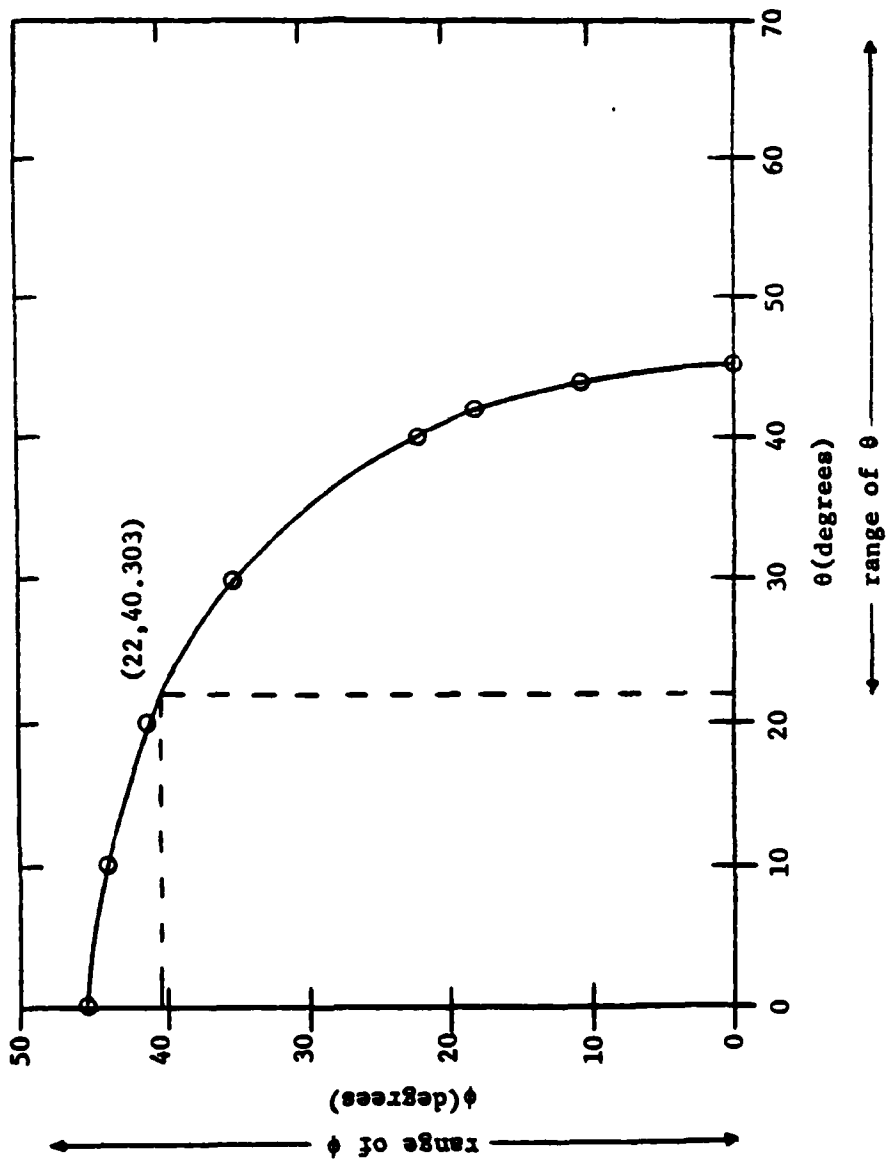

Figure 6.4. Graph of θ vs ϕ for $Y_7 = 0$.

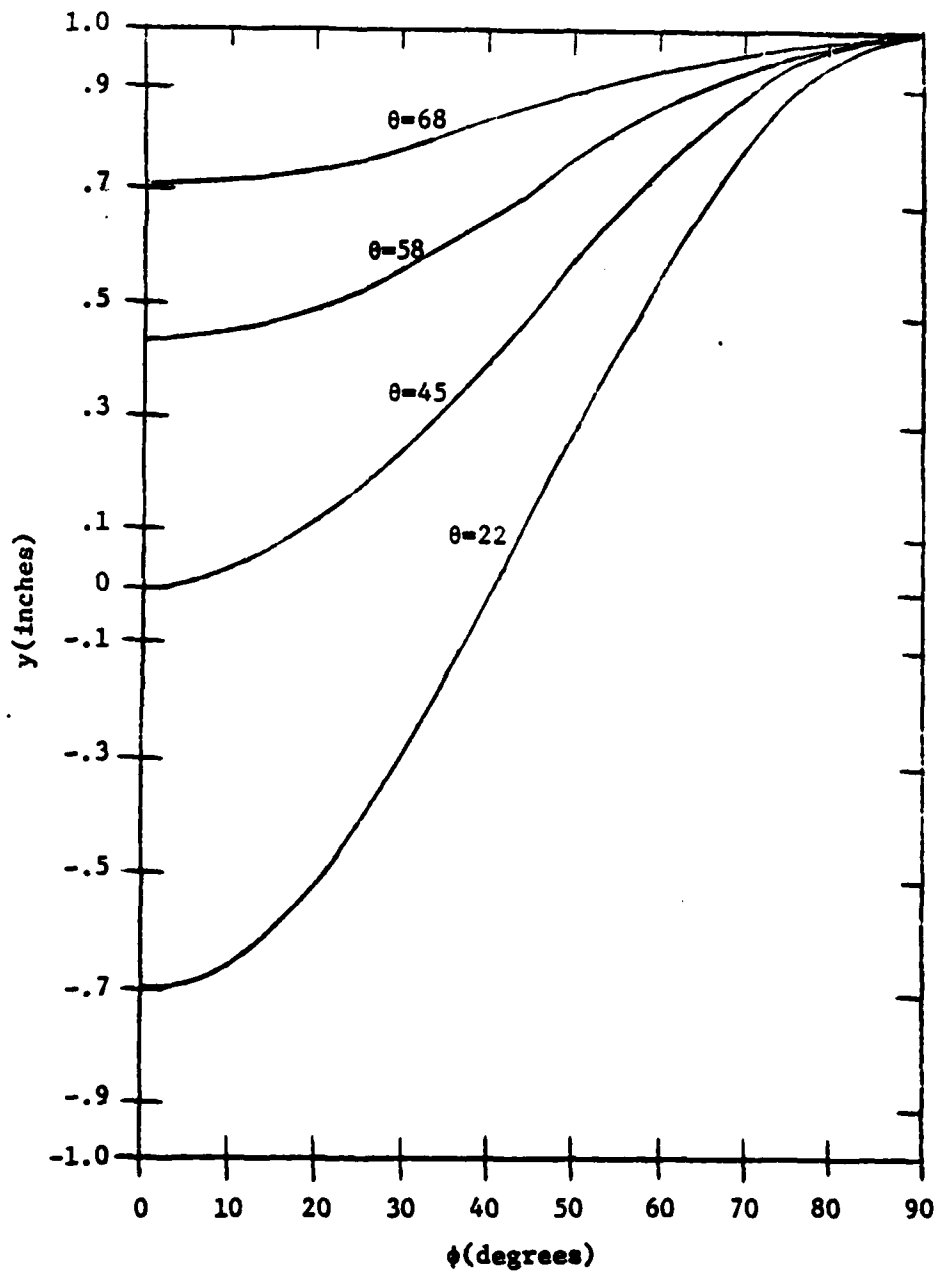

Figure 6.5. Graph of ϕ vs Y_7 for various values of θ .

VII. Tunnel Point to LDV Orientation

As a possible solution to the convergence problem, we will explore the use of an az-el device consisting of four independent az-el mirrors (see Figure 7.1). The success of this LDV system resides in its ability to frustrate the focal length of the lens and to not be limited by the focal length to access certain regions of the tunnel and in its ability to overcome the skewness caused by the orientation of the tunnel access window. The center of the device provides the origin of the rectangular Cartesian coordinate system on which to base the following analysis which has also been written as a computer program (Appendix C). The program calculates the necessary orientation of the device and mirrors such that the reflected laser beam off each mirror passes through the specified point in the tunnel after traversing the tunnel access window.

To get the laser beams to pass through a specified point in the tunnel, the device moves through calculated angles θ and ϕ such that the four mirrors maintain a planar surface.

As d_1 changes, the four mirrors move toward/away from the center of the device to keep the point at which each laser beam falls on a mirror at the center of each mirror. Thus, when each mirror is moved through its angles θ_1 and ϕ_1 , the location of each point does not change for each mirror. This four mirror arrangement will then provide convergence of the four laser beams at a specified point and complete overlap of the two probe volumes. Because the device and mirrors move as a planar unit and the mirrors are then fine adjusted to focus the laser beams at the point, the coherence length of the laser beam is not com-

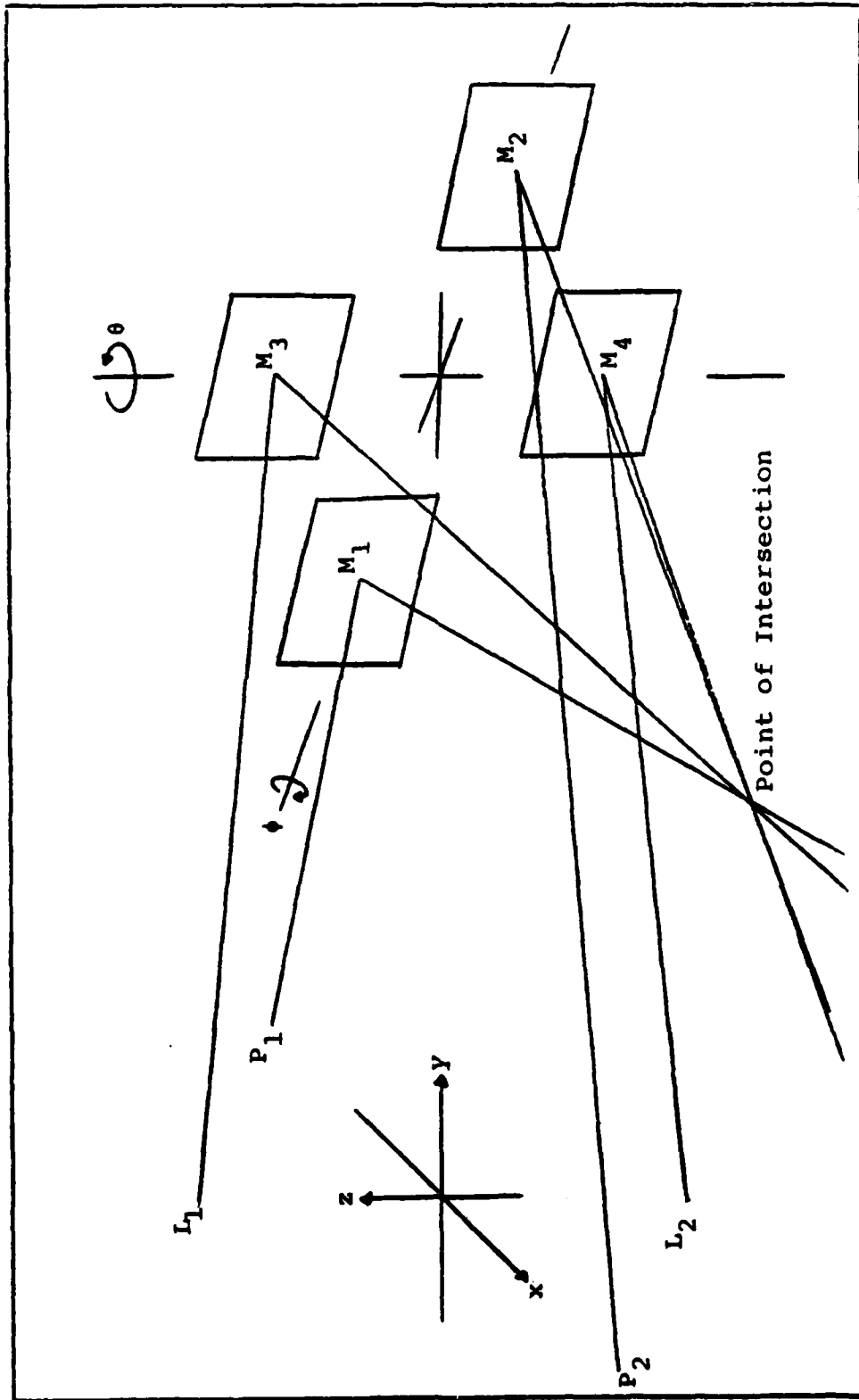

Figure 7.1. Four mirror device.

promised.

Given a tunnel point in the tunnel coordinate system, the first procedure to be accomplished is to translate and rotate the point into the coordinate system of the device. Using the transpose of the matrix in Equation (3.26), the following equation transforms the point from the tunnel into the device RCCS where (x,y,z) is in the tunnel and (x',y',z') is in the device.

$$P = \begin{bmatrix} x \\ y \\ z \end{bmatrix} \quad T = \begin{bmatrix} 0 \\ d_2 \\ 0 \end{bmatrix} \quad D = \begin{bmatrix} x' \\ y' \\ z' \end{bmatrix}$$

and

$$M = \begin{bmatrix} 0 & 1 & 0 \\ -1 & 0 & 0 \\ 0 & 0 & 1 \end{bmatrix}$$

Then, the equation for transforming is

$$D = M(P+T) \tag{7.1}$$

The next step is to find the angles θ and ϕ for the device. This will be called the course adjustment and the movement of each mirror through its individual θ_1 and ϕ_1 , the fine adjustment. Before this can be done, some of the mathematical and physical relationships needs to be developed.

If the components of the reflected vector could be found independently of knowing the orientation of the mirror(s), and only knowing a point on the mirror (i.e., the origin of the ray), the point in the tunnel, and the indices of refraction, then the angles of the mirror can be calculated.

Starting with the information shown in Figure 7.2, the rays in the three regions can be written in the point-direction form of a line (Equation 3.7). For region I, define

$$R = \frac{x - x_1}{a_1} = \frac{y - y_1}{a_2} = \frac{z - z_1}{a_3}$$

Using Equations (3.11), (3.17) and (3.18), region II is defined as

$$\frac{S}{k} = \frac{x - d_3}{(1 - k^2 (1 - a_1^2))^{1/2}} = \frac{y - y_2}{ka_2} = \frac{z - z_2}{ka_3}$$

For region III, define

$$T = \frac{x - d_3 - w}{a_1} = \frac{y - y_3}{a_2} = \frac{z - z_3}{a_3}$$

We then substitute in the remaining points to obtain specific values for R, S, and T. This results in

$$R_o = \frac{d_3 - x_1}{a_1} = \frac{y_2 - y_1}{a_2} = \frac{z_2 - z_1}{a_3}$$

$$S_o = \frac{k(d_3 + w - d_3)}{(1 - k^2 (1 - a_1^2))^{1/2}} = \frac{y_3 - y_2}{a_2} = \frac{z_3 - z_2}{a_3}$$

$$T_o = \frac{x_4 - d_3 - w}{a_1} = \frac{y_4 - y_3}{a_2} = \frac{z_4 - z_3}{a_3}$$

From the above equations

$$R_o = \frac{d_3 - x}{a_1} \tag{7.2a}$$

$$S_o = \frac{kw}{(1 - k^2 (1 - a_1^2))^{1/2}} \tag{7.2b}$$

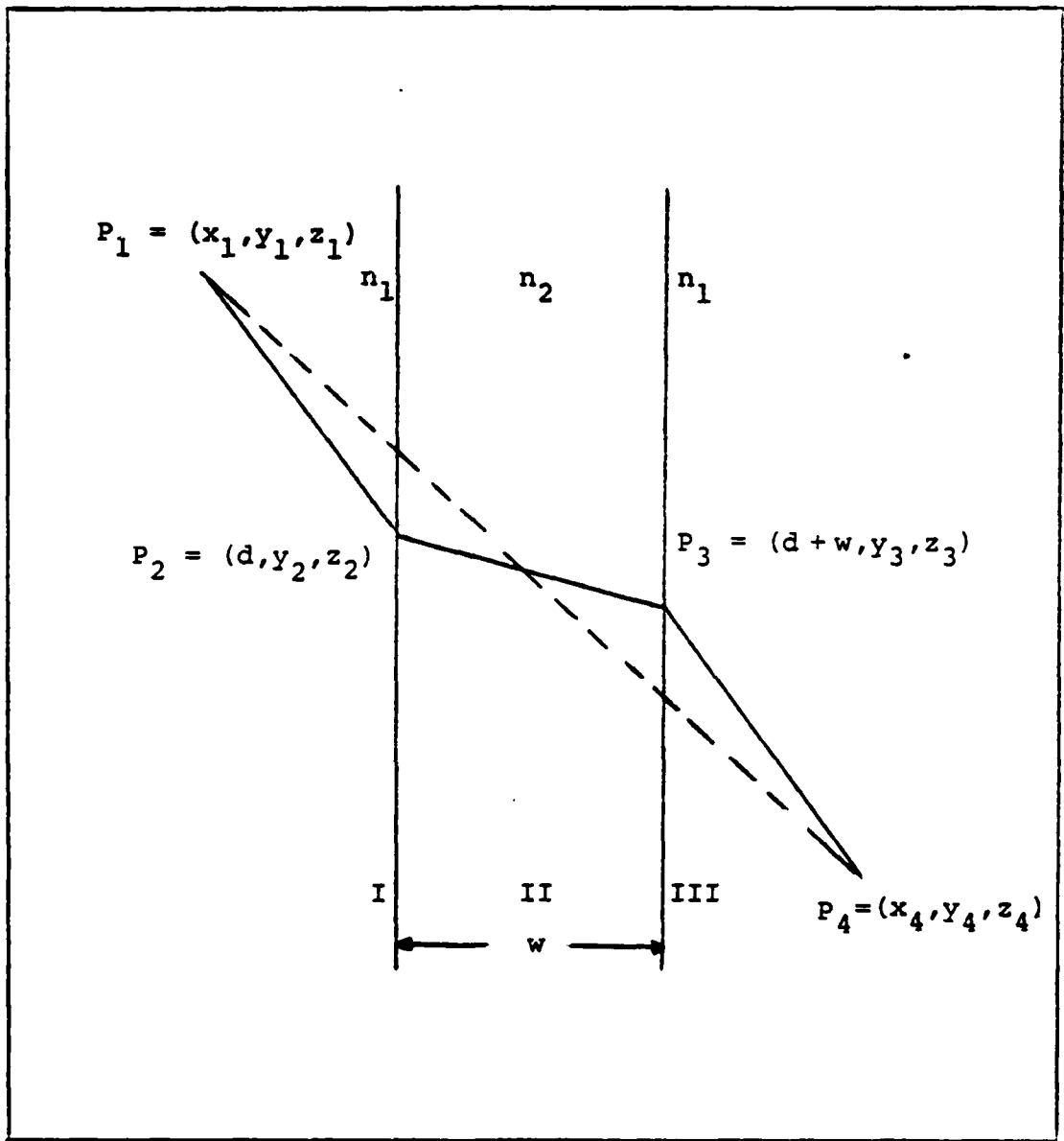

Figure 7.2. Scheme for finding α_1 given point in tunnel.

$$T_o = \frac{x_4 - d_3 - w}{\alpha_1} \quad (7.2c)$$

Then

$$y_2 - y_1 = \alpha_2 R_o \quad (7.3a)$$

$$y_3 - y_2 = \alpha_2 S_o \quad (7.3b)$$

$$y_4 - y_3 = \alpha_2 T_o \quad (7.3c)$$

and

$$z_2 - z_1 = \alpha_3 R_o \quad (7.4a)$$

$$z_3 - z_2 = \alpha_3 S_o \quad (7.4b)$$

$$z_4 - z_3 = \alpha_3 T_o \quad (7.4c)$$

Adding the three equations of (7.3) produces

$$y_4 - y_1 = \alpha_2 (R_o + S_o + T_o) \quad (7.5)$$

and adding the three equations of (7.4) produces

$$z_4 - z_1 = \alpha_3 (R_o + S_o + T_o) \quad (7.6)$$

Using Equation (7.2), the expression in Equation (7.5) and (7.6) is

$$R_o + S_o + T_o = \frac{x_4 - x_1 - w}{\alpha_1} + \frac{kw}{(1-k^2(1-\alpha_1^2))^{1/2}} = A(\alpha_1) \quad (7.7)$$

Therefore, Equation (7.5) and (7.6) becomes

$$\alpha_2 = \frac{y_4 - y_1}{A(\alpha_1)} \quad (7.8a)$$

$$\alpha_3 = \frac{z_4 - z_1}{A(\alpha_1)} \quad (7.8b)$$

Using Equation (7.7), Equation (3.14) becomes

$$\alpha_1^2 + \left[\frac{y_4 - y_1}{A(\alpha_1)} \right]^2 + \left[\frac{z_4 - z_1}{A(\alpha_1)} \right]^2 = 1$$

$$[A(\alpha_1)]^2 (1 - \alpha_1^2) - (y_4 - y_1)^2 - (z_4 - z_1)^2 = 0 \quad (7.9)$$

From Equation (7.8), the α_1 which satisfies this equation needs to be found. Once the α_1 is found, it becomes a simple matter to solve for α_2 and α_3 . Any procedure used to find the zeros of a real function, such as the Newton-Raphson method, can be used to find α_1 . The computer program listed in Appendix C implements the IMSL subroutine ZREAL2 (Ref 9) and an externally defined, single-argument, real function (i.e., Equation (7.8)). The purpose of this routine is to find the real zeros of a real function when the initial guesses are good.

Existing computer applications of iterative techniques will iterate toward zeros of a function, but the initial starting values for these schemes may pose a significant problem. If the initial point is not close to an actual zero, the iterative techniques often diverge. But we can provide an initial, good guess of α_1 by calculating α_1 as

$$\alpha_1 = \frac{x_4 - x_1}{((x_4 - x_1)^2 + (y_4 - y_1)^2 + (z_4 - z_1)^2)^{1/2}}$$

This is the direction cosine of the directed line between the mirror and tunnel points (see Figure 7.2). Since the ratio of the indices of refraction n_1/n_2 is close to one, the direction cosines of the refracted ray in the window will be close to the values for the incident ray and will provide an initial, good guess for a zero value.

Once each of the reflected vector's components are known, the

angles θ and ϕ can be found because the free space equations of the incident vectors are known. Based on Figure 7.3, the incident and reflected vector \vec{V}_i and \vec{V}_r are normalized. Since the vectors are

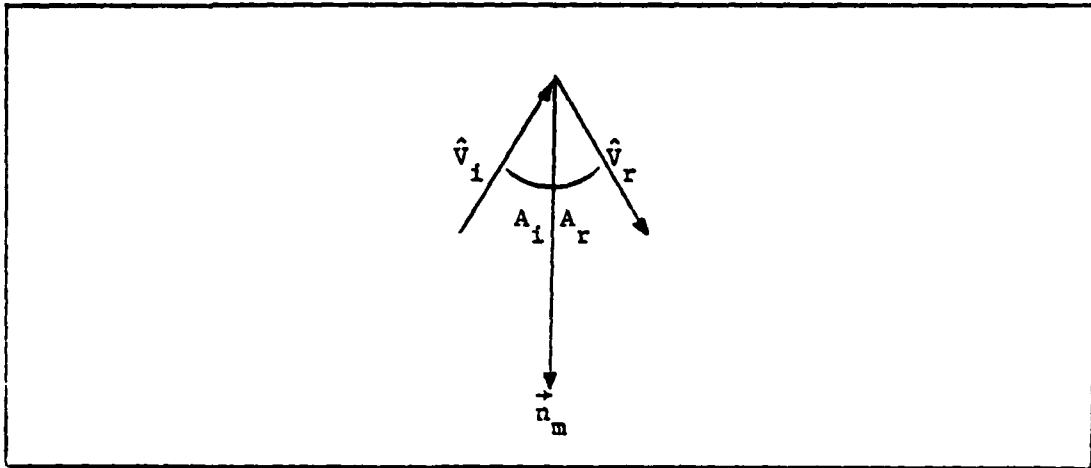

Figure 7.3. Vector addition.

normalized, they each have unit length and subtracting \hat{V}_i from \hat{V}_r produces a vector which bisects the angle between them. By the physics of a plane mirror, this vector is the mirror normal. By making the normal a unit vector and using Equation (4.4), and setting the k-components equal, we can solve for

$$\phi = \sin^{-1} (n_3) \quad (7.10)$$

Knowing ϕ , using Equation (3.8), and setting the j-components equal results in

$$\delta = \sin^{-1} \frac{n_1}{(1-n_3^2)^{1/2}} \quad (7.11a)$$

By definition, $\delta = \theta - 90$, therefore

$$\theta = \delta + 90 \quad (7.11b)$$

To apply this information to the LDV setup in Figure 1.1, but with Figure 7.1 in place of M1, the procedure would be as follows:

- (1) rotate the tunnel point using Equation (7.1),
- (2) find the pseudo reflected vector off the device using $P_1 = (0,0,0)$; find the α_1 value which satisfies Equation (7.9) and substitute it into Equations (7.7) and (7.8),
- (3) use the pseudo incident vector $\hat{V}_1 = (0,1,0)$, Equations (7.10) and (7.11) to determine the course values of θ , ϕ , and δ for the device,
- (4) use Equations (3.5), (3.6), (4.6) and (4.7) to find the center of each mirror in the device coordinate system,
- (5) using the location of a mirror center, find an α_1 value which satisfies Equation (7.9) and substitute this value into Equations (7.7) and (7.8),
- (6) use the normalized free space vector for \hat{V}_1 and \hat{V}_2 , which originates either in the x-y or y-z plane, the reflected vector found in step (5), Equations (7.10) and (7.11), to determine the fine adjustment values of θ_1 , ϕ_1 , and δ_1 for the mirror,
- (7) repeat steps (5) and (6) for the remaining three mirrors,
- (8) use the procedure outlined in Chapter V to determine the transformation matrix.

To see how well this procedure works, the method of calculating the orientation of the probe volume given the point of interest is compared to the method of calculating the location of the probe volume given the orientation of the mirror. The results of this comparison can be seen in Table III. In each case, the four-mirror system correctly calculated each mirror's orientation and the rays exactly converged to the desired point.

TABLE III
Comparison of Single-mirror and Four-mirror System

| Case | SINGLE-MIRROR SYSTEM | | | FOUR-MIRROR SYSTEM | | |
|------|-----------------------------|----------------------------|-------------------------|--------------------|--|--------------|
| | Angle (θ, ϕ) | Error* (Position) | Error** (Separation) | Mirror | Angle (θ, ϕ) | Error |
| 1 | 45,0 | ϕ | ϕ | 1 2 3 4 | 45,0 45,0 45,0 45,0 | |
| 2 | 45,-46 | .003396225 (.100641 mm) | .064559 (1.640 mm) | 1 2 3 4 | 44.999,-45.997 45,-46.002 44.996,-46.003 45.004,-45.996 | (See NOTE 3) |
| 3 | 34,22 | .0006688276 (.01699 mm) | .0070253 (.17844 mm) | 1 2 3 4 | 34,21.999 34,22 34.001,22 33.999,21.999 | |

*error due to skewness (i.e., distance between skew lines)

**error due to separation of probe volumes

NOTE 1: Error for single-mirror system is given in inches.

NOTE 2: Angles for four-mirror system converted from radian measure of output; therefore, there may be some roundoff error.

NOTE 3: Both the distance between probe volumes and the minimum distance between lines were 0.

VIII. Results, Conclusions and Recommendations

Results

The results of this investigation include:

(1) The mathematical analysis necessary to perform a ray trace of each laser beam in a laser velocimeter setup.

(2) A computer code (Appendix B) which models the AEDC proposed LDV setup. The computer code reads in the azimuth and elevation angles of the mirror then analytically determines the location of the probe volumes in the tunnel and the transformation matrices for the velocities measured by each probe volume.

(3) The mathematical analysis which demonstrates the conditions for convergence of each pair of laser beams for the AEDC proposed LDV system.

(4) The mathematical analysis necessary to determine the orientation of the mirror such that the reflected beam passes through the specified point after traversing the tunnel access window.

(5) A computer code (Appendix C) which performs the calculations necessary to obtain the information in (4) above.

Conclusions

On the basis of the results obtained in the analysis of the proposed system and the alternative system, the following conclusions are drawn:

(1) The original setup does not always provide complete intersection of the converging laser beams nor does it provide complete over-

lap of the two probe volumes.

(2) Given a set of criteria on the amount of overlap of the laser beams and the probe volumes, the useable tunnel volume the LDV can access is drastically reduced.

(3) Skewness of the laser beams is caused by trying to bend a planar set of rays through a window which is oblique to the rays.

(4) The alternative system guarantees convergence and overlap but, may still be limited by the tunnel geometry and the technology to construct the mirror device.

Recommendations

Based on the original course of the study and observations made during the investigation, the following recommendations are proposed for further study:

(1) The basis of this investigation was the assumption of equal indices of refraction for inside and outside the tunnel, and for each pair of laser beams. Since the laser beams normally experience different indices of refraction for air and glass, and the index of refraction in the tunnel may not be the same as outside the tunnel, further study of the proposed system may indicate if the convergence of the beams and overlap of the probe volumes are better or worse.

(2) Although the AEDC proposed system may not be useable, the sampling scheme for a probe volume not perpendicular to the flow could still be investigated.

(3) Should the proposed solution to the original setup be considered unuseable to the personnel at AEDC, then an uncertainty analysis could be performed on the system.

(4) Throughout the analysis, the value of d_1 was held constant. Further study of both systems may be done by varying d_1 to determine the effects on the systems.

(5) One assumption used throughout the analysis was that the thickness of the mirror was not considered a factor in determining the location of the points. If further study is done on either of these LDV systems, then the displacement due to the thickness of the mirror will have to be taken into account.

Bibliography

1. Barrett, D. O., and T. V. Giel, Jr. Studies of the Statistical Bias and Signal Characteristics of Laser Velocimeters. AEDC-TR-78-65 (ADA079634). Arnold AFS, TN: Arnold Engineering Development Center, January 1980.
2. Brayton, D. B., H. T. Kalb, and F. L. Crosswy. "Two-Component Dual-Scatter Laser Doppler Velocimeter with Frequency Burst Read-out," Applied Optics, 12: 1145-1156 (June 1973).
3. -----, and W. H. Goethert. "A New Dual Scatter Laser Doppler-Shift Velocity Measuring Technique," ISA Transactions, 10: 40-50 (1971).
4. Cline, V. A., and H. T. Bentley. Applications of a Dual Beam Velocimeter to Turbulent Flow Measurements. AEDC-TR-74-56 (AD785352). Arnold AFS, TN: Arnold Engineering Development Center, September 1974.
5. Crosswy, F. L., and D. B. Brayton. Design and Evaluation of LDV for AEDC PWT 4-ft Transonic Wind Tunnel. AEDC-TR-78-30 (ADA057327). Arnold AFS, TN: Arnold Engineering Development Center, July 1978.
6. Durrani, Tariq S., and Clive A. Greated. Laser Systems in Flow Measurement. New York: Plenum Press, 1977.
7. Durst, F., et al. Principles and Practice of Laser-Doppler Anemometry. New York: Academic Press, 1981.
8. Gallert, W., et al. The VNR Concise Encyclopedia of Mathematics. New York: Van Nostrand Reinhold Company, 1977.
9. Granted, I., and C. A. Greated. "Periodic sampling in laser anemometry," Journal of Physics E: Scientific Instruments, 13: 571-4 (May 1980).
10. IMSL Library Reference Manual (Edition 9). Houston, TX: International Mathematical & Statistical Libraries, Inc., 1982.
11. Lennert, A. E., et al. Summary Report of the Development of a Laser Velocimeter to be Used in AEDC Wind Tunnels. AEDC-TR-70-101 (AD871321). Arnold AFS, TN: Arnold Engineering Development Center, July 1980.
12. Mallory, Virgil S., and Chauncey W. Oakley. Plane Geometry. Chicago: Benj. H. Sanborn and Co., 1953.

13. Roesler, W. H., W. H. Stevenson, and H. D. Thompson. Investigation of Bias Errors in LDV Measurements. AFWAL-TR-80-2105 (ADA097040). Wright-Patterson AFB, OH: Air Force Wright Avionics Laboratory, December 1980.
14. Sears, Francis Weston, and Mark W. Zemansky. The Complete University Physics (2nd Edition). Reading, Massachusetts: Addison-Wesley Publishing Company, Inc., 1955.
15. Thompson, H. Doyle, and Warren H. Stevenson (ed.). Laser Velocimetry and Particle Sizing. New York: Hemisphere Publishing Corporation, 1978.
16. Whiffen, M. C. "Polar Response of an LV Measurement Volume," Minnesota Symposium on Laser Anemometry Proceedings, edited by E.R.G. Eckert. Minneapolis MN: University of Minnesota, January 1976.

Appendix A

Probe Volume Analysis

To use a laser Doppler velocimeter (LDV) system, certain conditions on the probe volumes must be met before the system can be deemed useable (i.e., able to accurately determine the location of the probe volume and the velocity of the boundary layer of interest).

The first condition concerns the overlap of the laser beams to produce a useable probe volume. For example, suppose the rays must overlap by 90% (Figure A.1). This requirement is imposed for the

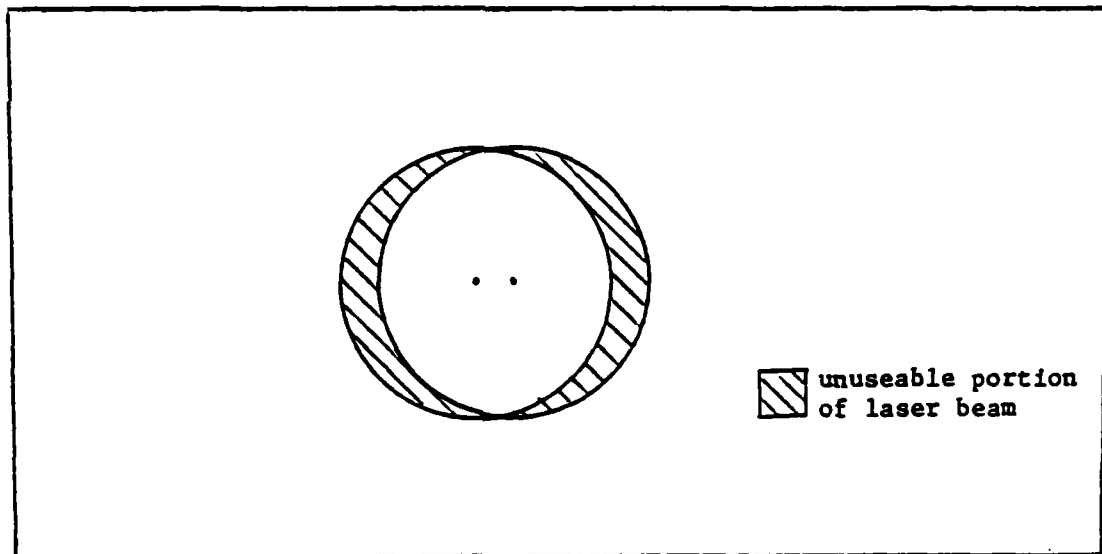

Figure A.1. Probe volume formed by overlapping laser beams.

creation of enough fringes and enough energy in each fringe to be reflected by the seeds in the flow. But, the separation of the laser beams is a dynamic quantity which increases as the absolute value of ϕ increases. Therefore, any criteria for overlap of laser beams which is

determined may not provide enough coverage by the LDV system to make it worthwhile. For Figure A.2, θ was held at a value of 42 degrees and ϕ was swept from 0 to 49 degrees. The laser beams intersected at $\phi = 0$ and they separate as the angle ϕ gets larger.

The second condition concerns the overlapping of probe volumes for measurement of the x- and y-components of velocity. When measuring the velocity of a boundary layer, this separation cannot be very great or the x and y velocity measurements may be taken from different boundary layers. For example, in Figure A.3, ϕ was held at a value of zero and θ was swept from 22 to 68 degrees. This graph represents the midpoint between the rays which originate in the x-y plane, the center of the probe volume. The graph of the y-z plane midpoint values are consistently less than those for the x-y plane (except at $\theta = 45$ where they are equal) and are represented as the distance from the x-y plane values in Figure A.4.

If the two criteria, overlap of the laser beams and probe volumes, are combined with user-defined values for each and a constant d_1 , then a two-dimensional view of the useable tunnel volume can be visualized.

Suppose the criteria are defined as the minimum distance between converging laser beams to be less than 0.1 mm and the distance between probe volume centers to be less than 1.0 mm. Figure A.5 is a two-dimensional representation of the useable mirror orientations. The useable area falls between the upper and lower graphs, the upper graph and $\phi = 0$, and the figure is symmetric for negative values of ϕ . The steps and discontinuities in the figure are a product of the two criteria being combined and specifically of the second criterion. The

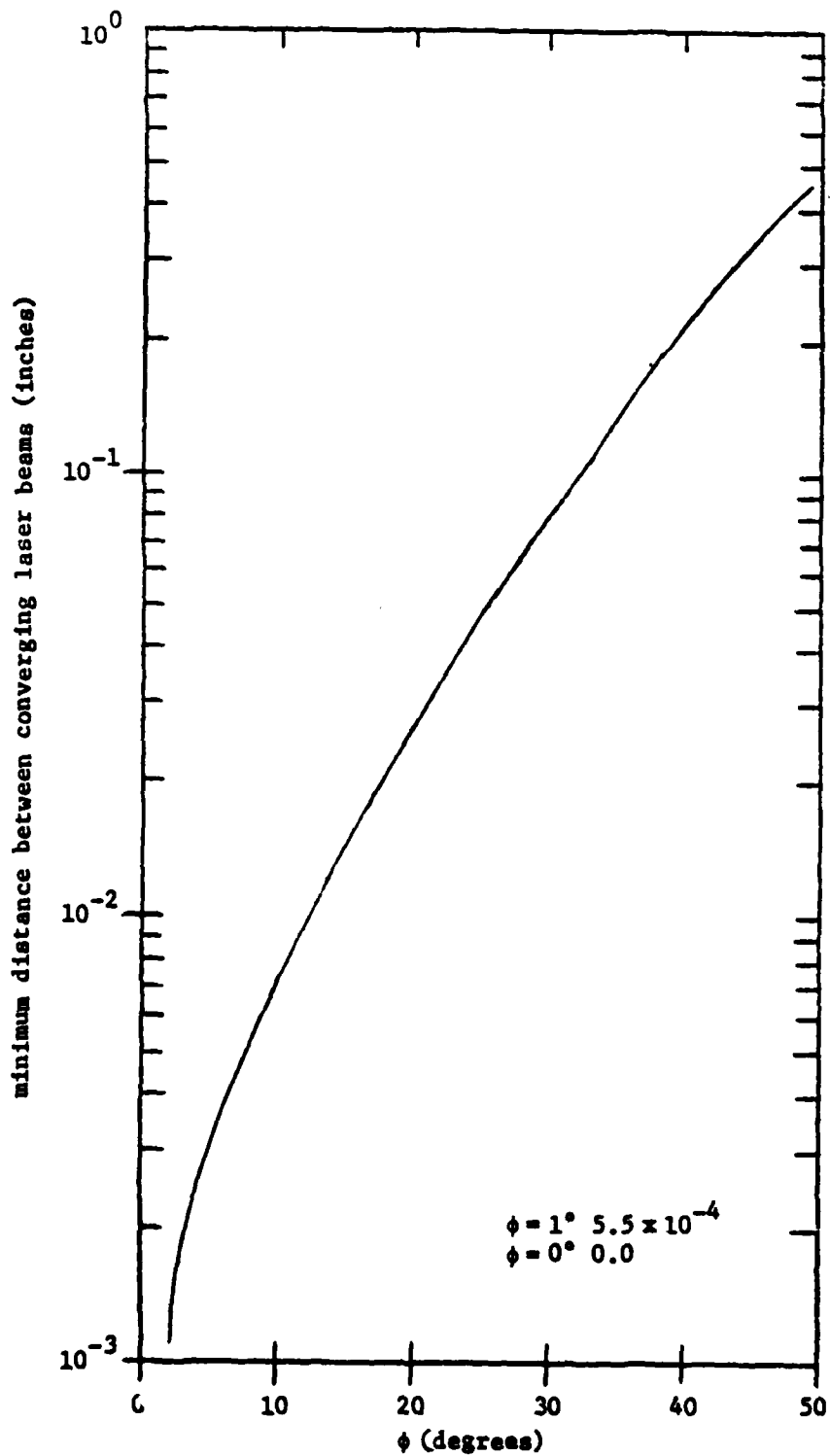

Figure A.2. Plot of laser beam overlap for $\theta = 42^\circ$.

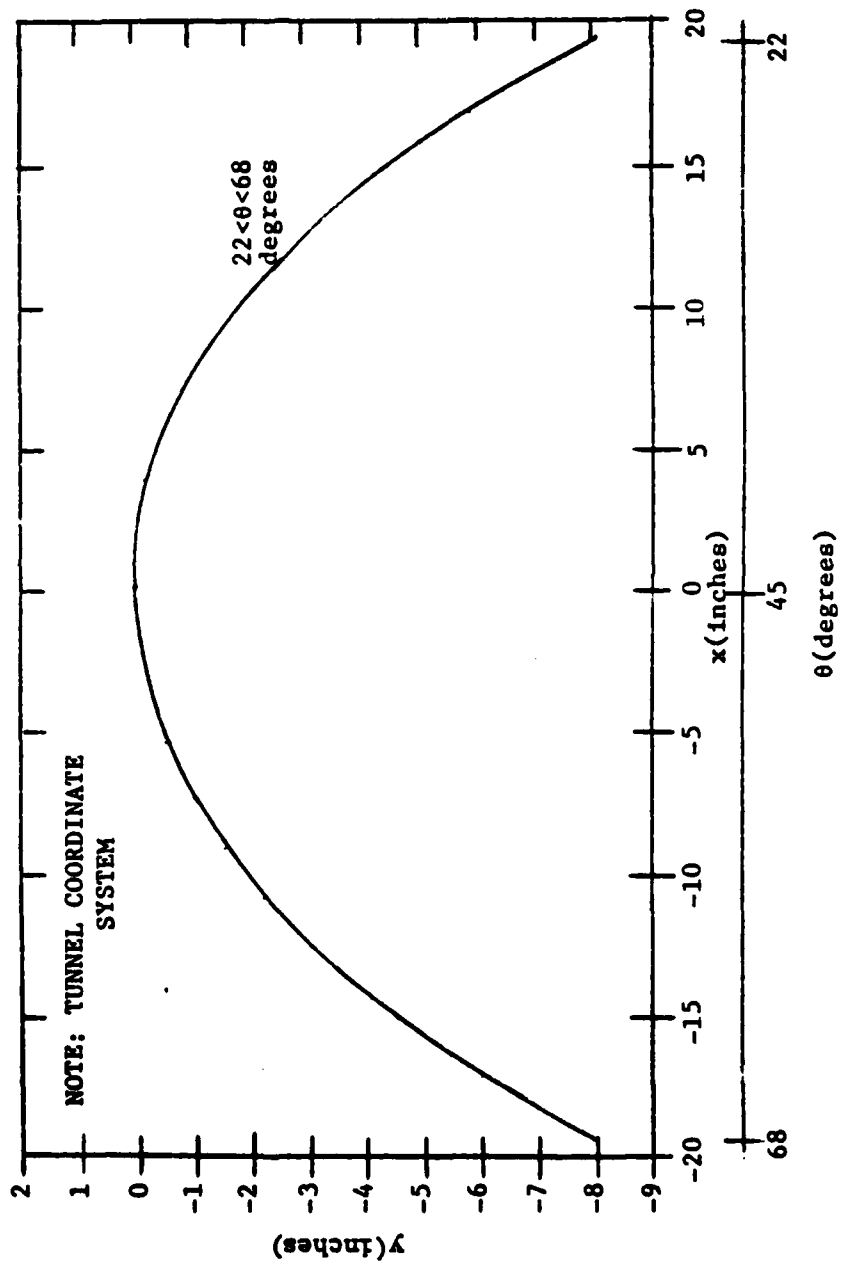

Figure A.3. Plot of $\phi = 0$.

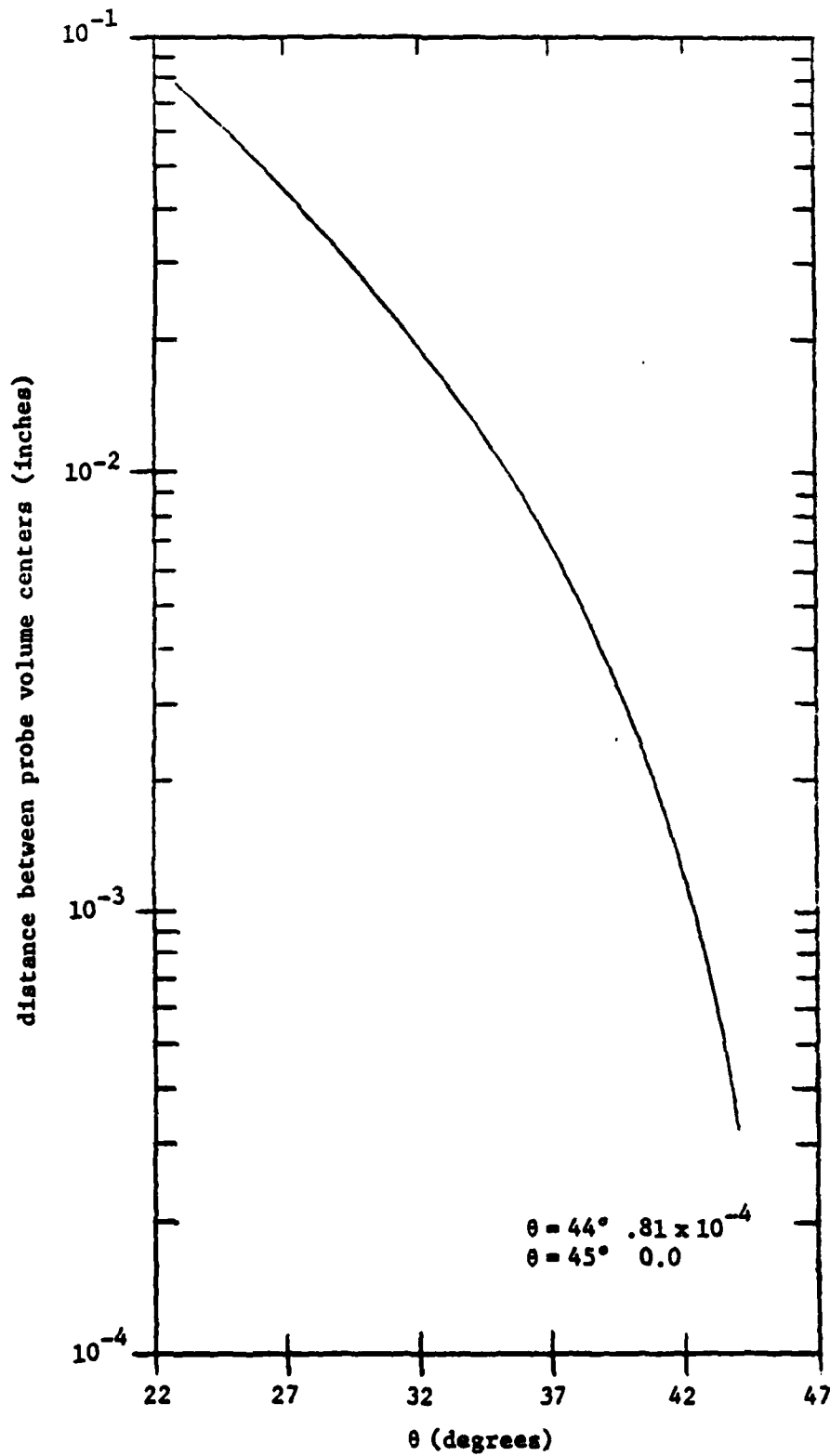

Figure A.4. Plot of distance between probe volume centers for $\phi = 0$.

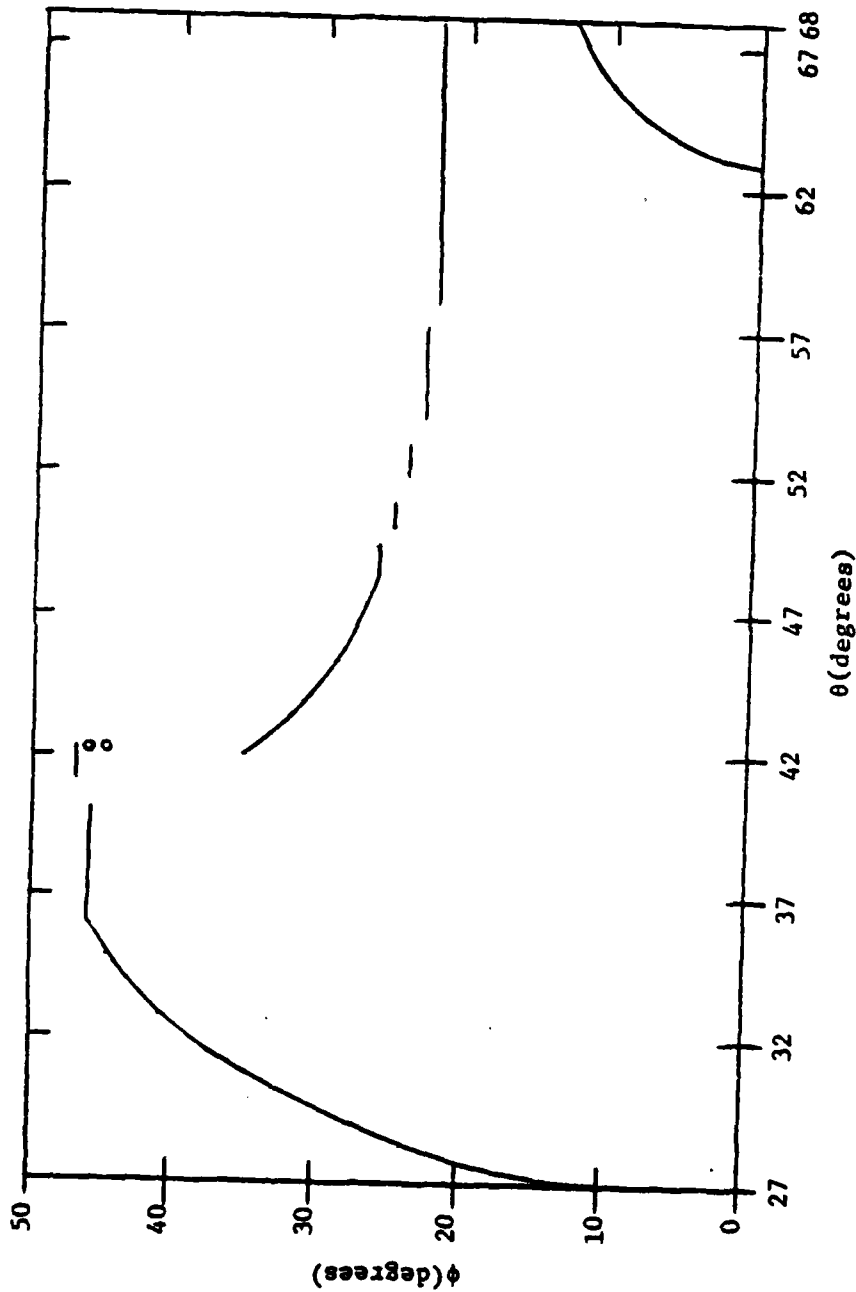
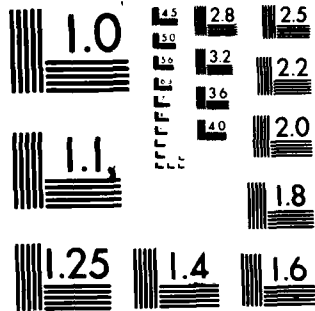

Figure A.5. Graph of useable region for the conditions of minimum distance between laser beams $<0.1\text{ mm}$ and distance between probe volume centers $<1.0\text{ mm}$.

distance between probe volume centers is somewhat distorted by choosing the center of the probe volume as the midpoint on the minimum distance line between the two skew lines. As θ and ϕ change, the relationship between probe volume centers is not a well defined phenomenon since the center changes as the distance between the converging beams change and as the rays are moved through the angles θ and ϕ .

As the conditions for a useable probe volume are restricted, the useable area of the tunnel becomes smaller and more continuous as seen in Figures A.6 and A.7. It does not suffice to look only at distance between laser beams or only at distance between probe volume centers since both conditions must be met for the LDV system to be useable.



MICROCOPY RESOLUTION TEST CHART
NATIONAL BUREAU OF STANDARDS 1963-A

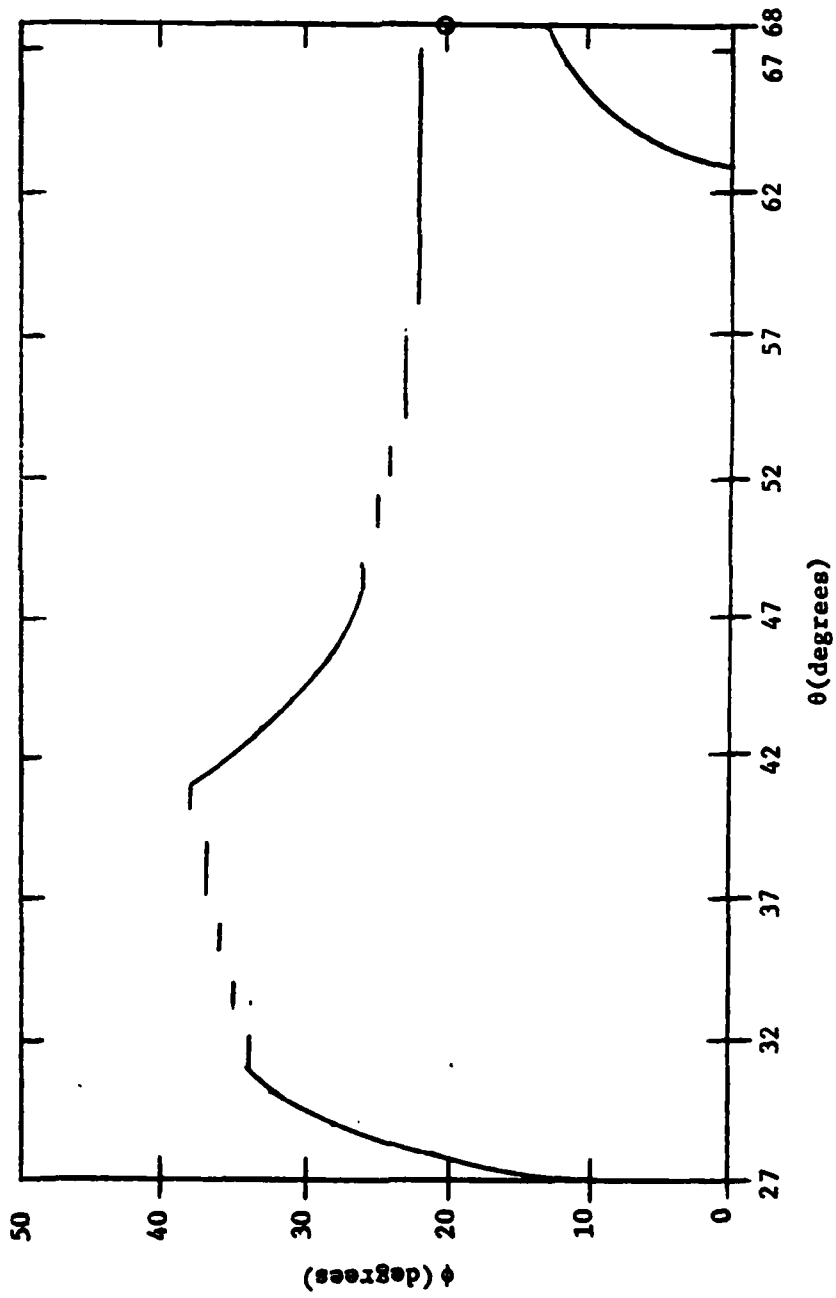

Figure A.6. Graph of useable region for the conditions of minimum distance between laser beams $<0.05\text{ mm}$ and distance between probe volume centers $<1.0\text{ mm}$.

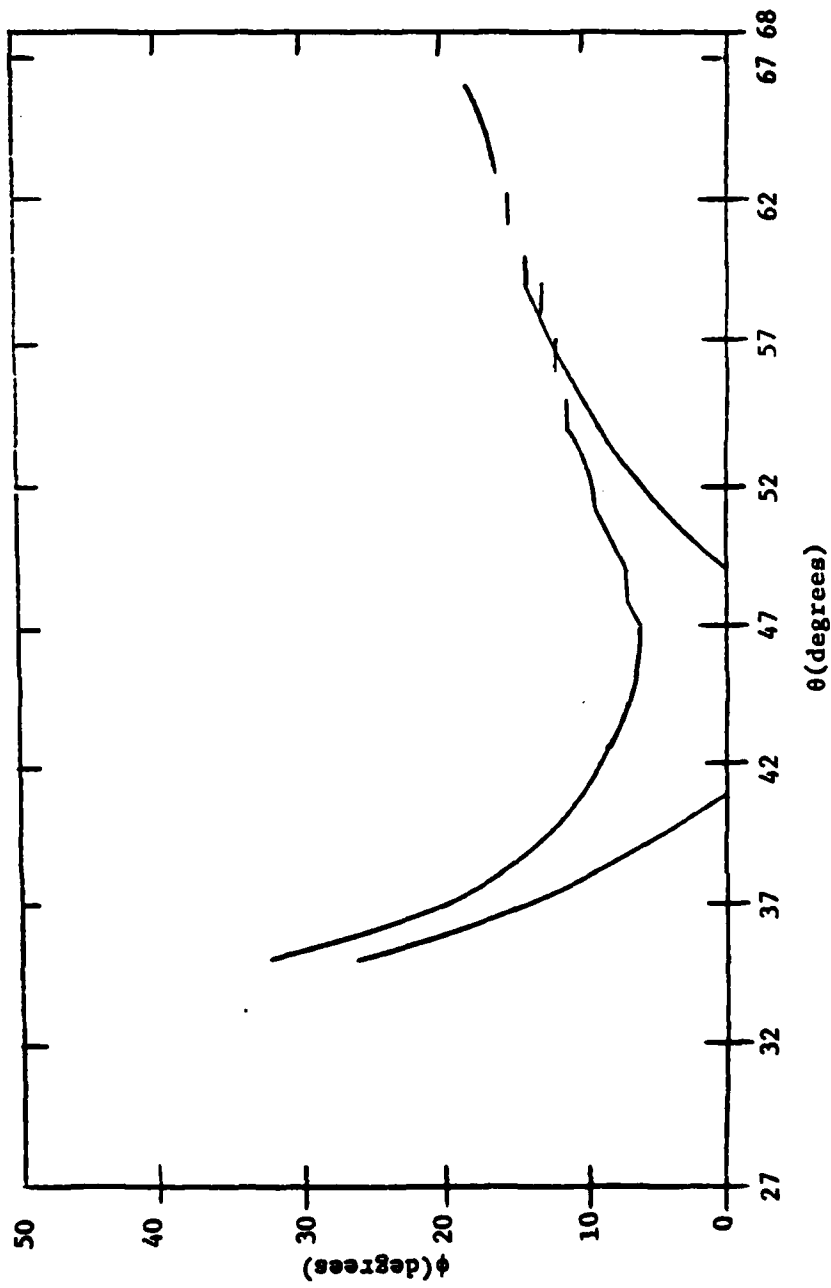

Figure A.7. Graph of useable region for the conditions of minimum distance between laser beams, and probe volume centers $<0.05\text{ mm}$.

Appendix B

Laser Doppler Velocimeter Program Listing

Program LDV has within the code, various distances and physical relationships set to user defined values. The computer code then reads in the azimuth angle θ and the elevation angle ϕ of the mirror. From this information the program analytically determines the location of the resultant probe volume in the tunnel and the matrices for transforming the measured velocity from the probe volume coordinate system to the mirror coordinate system.

The program was designed to be flexible enough to accommodate various changes and additions to the code such as redefining constants, values to be read in and output by the user, and traversing of more than one window.

If the code cannot be used as a whole, each section and subroutine contains insight into the physics of the situation and the underlying mathematical representation.

PROGRAM LDV

C THIS PROGRAM IS DESIGNED TO DETERMINE
C THE LOCATION AND ORIENTATION OF THE
C PROBE VOLUME, FOR AN AEDC PROPOSED LASER
C DOPPLER VELOCIMETER (LDV) SETUP, GIVEN
C THE ROTATION OF THE MIRROR THROUGH THE
C ANGLES THETA AND PHI

C PROGRAM CREATED BY:

C CAPT GARY S. KRAJCI
C AIR FORCE INSTITUTE OF TECHNOLOGY
C WRIGHT-PATTERSON AFB OH 45433
C 25 OCTOBER 1983

C *****
C * DEFINITION OF NOTATION *
C * PROGRAM LDV *
C * *****

C ***** TUNNEL/LDV CONFIGURATION *****

C D1 - DISTANCE FROM THE MIRROR (M1) TO THE LENS (L1)
C D2 - DISTANCE FROM M1 TO THE ORIGIN OF THE TUNNEL RECTANGULAR
C CARTESIAN COORDINATE SYSTEM (RCCS)
C D3 - DISTANCE FROM M1 TO THE ACCESS WINDOW OF THE WIND TUNNEL
C F - FOCAL LENGTH OF L1
C W - THICKNESS OF THE ACCESS WINDOW OF THE WIND TUNNEL
C S - DISTANCE BETWEEN THE TWO PLANE PARALLEL LASER BEAMS BEFORE THEY
C ENTER L1
C G1,G2,G3 - INDICES OF REFRACTION FOR THE AREAS OUTSIDE THE TUNNEL,
C THROUGH THE WINDOW, AND INSIDE THE TUNNEL
C - FOR THE GREEN LASER IN THE X-Y PLANE

```

C B1,B2,B3 - INDICES OF REFRACTION FOR THE AREAS OUTSIDE THE TUNNEL,
C           THROUGH THE WINDOW, AND INSIDE THE TUNNEL
C           - FOR THE BLUE LASER IN THE Y-Z PLANE
C THETA - ANGLE MADE BY M1 AND THE X-AXIS OF THE MIRROR'S RCCS
C PHI - ANGLE MADE BY THE MIRROR NORMAL AND THE X-Y PLANE
C DELTA - ANGLE MADE BY THE MIRROR NORMAL AND THE X-Z PLANE
C           - DELTA = THETA - 90

C ***** X-Y PLANE ANALYSIS *****
C V - ARRAY OF VECTORS USED TO DESCRIBE THE PATHS OF THE LDV LASER
C       BEAMS IN THE X-Y PLANE
C PV - ARRAY OF VECTORS USED TO DESCRIBE THE PROBE VOLUME COORDINATE
C       SYSTEM
C R - ARRAY OF VECTORS WHICH CONTAINS THE DIRECTIONAL COSINES TO CHANGE
C       THE MEASURED VELOCITY IN THE PROBE VOLUME RCCS TO THE MIRROR RCCS
C - R IS THE TRANSPOSE OF THE MATRIX CONTAINING THE VECTORS PV
C OMEGA - ANGLE MADE BY THE TWO CONVERGING LASER BEAMS WHICH CREATE
C           THE PROBE VOLUME
C P - ARRAY OF POINTS USED TO DETERMINE THE LOCATION OF THE PROBE
C       VOLUME IN THE WIND TUNNEL
C XH,YH,ZH - LOCATION OF THE PROBE VOLUME IN THE TUNNEL RCCS
C HM - VECTOR USED TO STORE THE MIDPOINT OF THE SKEW LASER BEAMS. IF
C       THE LASER BEAMS CONVERGE, THEN THIS VALUE IS THE LOCATION OF THE
C       PROBE VOLUME

C ***** Y-Z PLANE ANALYSIS *****
C U - ARRAY OF VECTORS USED TO DESCRIBE THE PATHS OF THE LDV LASER BEAMS
C       IN THE Y-Z PLANE
C VP - ARRAY OF VECTORS USED TO DESCRIBE THE PROBE VOLUME COORDINATE
C       SYSTEM
C T - MATRIX OF VECTORS WHICH CONTAINS THE DIRECTIONAL COSINES TO CHANGE
C       THE MEASURED VELOCITY IN THE PROBE VOLUME RCCS TO THE MIRROR RCCS
C - T IS THE TRANSPOSE OF THE MATRIX CONTAINING THE VECTORS VP

```

```

C ALPHA - ANGLE MADE BY THE TWO CONVERGING LASER BEAMS WHICH CREATE
C THE PROBE VOLUME
C L - ARRAY OF POINTS (LOCATIONS) USED TO DETERMINE THE LOCATION OF THE
C PROBE VOLUME IN THE WIND TUNNEL
C XV,YV,ZV - LOCATION OF THE PROBE VOLUME IN THE TUNNEL RCCS
C VM - VECTOR USED TO STORE THE MIDPOINT OF THE SKEW LASER BEAMS. IF
C THE LASER BEAMS CONVERGE, THEN THIS VALUE IS THE LOCATION OF THE
C PROBE VOLUME

C ***** TRANSIENT VARIABLES *****
C I,J - INTEGER COUNTERS FOR DO LOOPS
C COUNT - A COUNTER USED TO TRACK THE DIFFERENT ORIENTATIONS OF THE LDV
C MIRROR
C PI - THE VALUE OF PI AS DEFINED BY THE COMPUTER
C CALC - VARIABLE USED IN THE CALCULATION OF THE VERTICLE INTERSECTION
C POINTS ON THE MIRROR
C ANSER - THE EUCLIDEAN DISTANCE BETWEEN TWO POINTS

C ***** FILES *****
C FILE 2 - CONTAINS THE INPUT ANGLES FOR THE PROBLEM
C FILE 4 - CONTAINS THE OUTPUT DATA:
C (1) POSITION OF THE GREEN LASER PROBE VOLUME IN THE
C TUNNELS RCCS
C (2) POSITION OF THE BLUE LASER PROBE VOLUME IN THE
C TUNNEL RCCS
C (3) ANGLES MADE BY THE CONVERGING GREEN & BLUE LASERS
C TO FORM THE PROBE VOLUMES
C FILE 6 - CONTAINS ANY ERROR OR PROBLEM STATEMENTS AS THE PROGRAM
C EXECUTES
C FILE 8 - CONTAINS THE ROTATION MATRICES FOR TRANSFORMING THE X & Y
C VELOCITY COMPONENTS FROM THE PROBE VOLUME TO THE
C MIRROR RCCS

```

```

C *****
C *
C * LASER DOPPLER VELOCIMETER
C *
C * MAIN PROGRAM
C *
C *****
      DOUBLE PRECISION D1,D2,D3,F,W,S,THETA,PHI,DELTA,B1,B2,B3,V(8,3)
      1,PV(3,3),OMEGA,G1,G2,G3,P(7,3),XM,YH,ZH,R(3,3)

      DOUBLE PRECISION U(8,3),VP(3,3),ALPHA,L(7,3),HM(3),VM(3)
      1,T(3,3),XV,YV,ZV,ANSER,PI,CALC

      INTEGER COUNT,I,J

      DATA D1,D2,D3/3.125D0,26.875D0,2.5D0/
      DATA F,W,S/30.0D0,0.375D0,1.0D0/
      DATA G1,G2,G3/1.364D0,1.523D0,1.364D0/
      DATA B1,B2,B3/1.364D0,1.523D0,1.364D0/

      OPEN(2,FILE='INLIV')
      OPEN(4,FILE='OUTLDV')
      OPEN(6,FILE='DEBUG')
      OPEN(8,FILE='ROTMAT')

      COUNT = 0
      PI = (4.0D0)*DATAN(1.0D0)

C WRITE HEADERS TO THEIR RESPECTIVE FILES

      WRITE(4,103)
      WRITE(4,104)
      WRITE(4,107)
      WRITE(8,105)
      WRITE(8,106)

```

```

C READ IN THE ANGLES OF THE MIRROR IN DEGREES
      10 READ(2,101,END=69)THETA,PHI
      COUNT = COUNT + 1
      DELTA = THETA - 90.000
C CONVERT THE ANGLES FROM DEGREES TO RADIAN (FORTKAN WORKS IN RADIAN)
      PHI = (PHI*PI)/180.000
      DELTA = (DELTA*PI)/180.000
      THETA = (THETA*PI)/180.000
C ***** LDV MIRROR ANALYSIS *****
C INITIALIZE THE LASER BEAM VECTORS WHICH EXIT L1 ON THEIR
C WAY TO M1
      V(1,1) = S/2.000
      V(1,2) = F
      V(1,3) = 0.000
      V(2,1) = -S/2.000
      V(2,2) = F
      V(2,3) = 0.000
      U(1,1) = 0.000
      U(1,2) = F
      U(1,3) = -S/2.000
      U(2,1) = 0.000
      U(2,2) = F
      U(2,3) = S/2.000

```

C COMPUTE THE LOCATION OF THE POINTS MADE BY THE LASER BEAMS
C ON THE MIRROR IN THE M1 RCCS

P(1,1) = (S*(F-D1))/((S*DTAN(THETA))-(2.0D0*F))
P(1,2) = P(1,1)*DTAN(THETA)
P(1,3) = 0.0D0

P(2,1) = (S*(F-D1))/((S*DTAN(THETA))+(2.0D0*F))
P(2,2) = P(2,1)*DTAN(THETA)
P(2,3) = 0.0D0

CALC = 2.0D0*F*DCOS(PHI)*DSIN(DELTA)

L(1,1) = 0.0D0
L(1,2) = (S*(D1-F)*DSIN(PHI))/(CALC-S*DSIN(PHI))
L(1,3) = (S*(F-L(1,2)-D1))/(2.0D0*F)

L(2,1) = 0.0D0
L(2,2) = (S*(F-D1)*DSIN(PHI))/(CALC+S*DSIN(PHI))
L(2,3) = (S*(D1+L(2,2)-F))/(2.0D0*F)

CALL MIRROR(F,D1,PHI,THETA,F,L,U,U)

C ***** WINDOW VECTOR ANALYSIS *****

```
CALL VECTOR(G1,G2,V(3,1),V(3,2),V(3,3),V(5,1),V(5,2),V(5,3))
CALL VECTOR(B1,B2,U(3,1),U(3,2),U(3,3),U(5,1),U(5,2),U(5,3))

CALL VECTOR(G1,G2,V(4,1),V(4,2),V(4,3),V(6,1),V(6,2),V(6,3))
CALL VECTOR(B1,B2,U(4,1),U(4,2),U(4,3),U(6,1),U(6,2),U(6,3))

CALL VECTOR(G1,G3,V(3,1),V(3,2),V(3,3),V(7,1),V(7,2),V(7,3))
CALL VECTOR(B1,B3,U(3,1),U(3,2),U(3,3),U(7,1),U(7,2),U(7,3))

CALL VECTOR(G1,G3,V(4,1),V(4,2),V(4,3),V(8,1),V(8,2),V(8,3))
CALL VECTOR(G1,G3,U(4,1),U(4,2),U(4,3),U(8,1),U(8,2),U(8,3))
```

```

C ***** POINT DIRECTION FORM OF LINE *****
C SOLVE FOR POINTS 3 TO 6 USING THE POINT DIRECTION FORM OF A
C LINE. THE FORM IS
C
C      X - X1   Y - Y1   Z - Z1
C      ----- = ----- = -----
C           A         B         C
C
C WHERE X1,Y1,Z1 IS THE KNOWN POSITION OF THE POINT AND A,B,C
C ARE THE DIRECTION COMPONENTS OF THE VECTOR
C
C SOLVE FOR POINT #3
      P(3,1) = D3
      P(3,2) = P(1,2)+(V(3,2)/V(3,1))*(D3-P(1,1))
      P(3,3) = (V(3,3)/V(3,1))*(D3-P(1,1))
      L(3,1) = D3
      L(3,2) = L(1,2)+(U(3,2)/U(3,1))*D3
      L(3,3) = L(1,3)+(U(3,3)/U(3,1))*D3
C SOLVE FOR POINT #4
      P(4,1) = D3
      P(4,2) = P(2,2)+(V(4,2)/V(4,1))*(D3-P(2,1))
      P(4,3) = (V(4,3)/V(4,1))*(D3-P(2,1))
      L(4,1) = D3
      L(4,2) = L(2,2)+(U(4,2)/U(4,1))*D3
      L(4,3) = L(2,3)+(U(4,3)/U(4,1))*D3

```

C SOLVE FOR POINT #5

P(5,1) = D3+W
P(5,2) = P(3,2)+(V(5,2)/V(5,1))*W
P(5,3) = P(3,3)+(V(5,3)/V(5,1))*W
L(5,1) = D3+W
L(5,2) = L(3,2)+(U(5,2)/U(5,1))*W
L(5,3) = L(3,3)+(U(5,3)/U(5,1))*W

C SOLVE FOR POINT #6

P(6,1) = D3+W
P(6,2) = P(4,2)+(V(6,2)/V(6,1))*W
P(6,3) = P(4,3)+(V(6,3)/V(6,1))*W
L(6,1) = D3+W
L(6,2) = L(4,2)+(U(6,2)/U(6,1))*W
L(6,3) = L(4,3)+(U(6,3)/U(6,1))*W

```

C ***** LOCATION & ORIENTATION OF PROBE VOLUME *****
C SOLVE FOR POINT #7 - THE LOCATION OF THE PROBE VOLUME
    CALL LOCATE(V(7,1),V(7,2),V(7,3),V(8,1),V(8,2),V(8,3),P(5,1)
    1,P(5,2),P(5,3),P(6,1),P(6,2),P(6,3),HM,COUNT)
    CALL LOCATE(U(7,1),U(7,2),U(7,3),U(8,1),U(8,2),U(8,3),L(5,1)
    1,L(5,2),L(5,3),L(6,1),L(6,2),L(6,3),VM,COUNT)
C USING THE COORDINATE TRANSFORMATION FROM THE MIRROR RCCS TO
C THE TUNNEL RCCS, DETERMINE THE LOCATION OF THE PROBE VOLUME
C WITH RESPECT TO THE TUNNEL RCCS. THE ORIENTATION OF THE
C MIRROR COORDINATE SYSTEM IS A ROTATION OF -90 DEGREES AND A
C TRANSLATION OF A DISTANCE -D2
    XH = -HM(2)
    YH = HM(1)-D2
    ZH = HM(3)
    XV = -VM(2)
    YV = VM(1)-D2
    ZV = VM(3)
    CALL APART(XH,YH,ZH,XV,YV,ZV,ANSER)
C COMPUTE THE THE ANGLES ALPHA & OMEGA
    ALPHA = DIACOS((U(7,1)*U(8,1)+(U(7,2)*U(8,2)+(U(7,3)*U(8,3)))
    OMEGA = DIACOS((V(7,1)*V(8,1)+(V(7,2)*V(8,2)+(V(7,3)*V(8,3)))

```

```
C COMPUTE THE X,Y,Z AXES OF THE PROBE VOLUME
```

```
CALL PROBE(V(7,1),V(7,2),V(7,3),V(8,1),V(8,2),V(8,3),PV)
```

```
CALL PROBE(U(7,1),U(7,2),U(7,3),U(8,1),U(8,2),U(8,3),VP)
```

```
C TRANSPOSE THE MATRICES PV AND VP, THE NORMALIZED COORDINATE AXES OF  
C THE PROBE VOLUMES, TO OBTAIN THE MATRICES R AND T, WHICH ARE THE  
C DIRECTIONAL COSINE ROTATION MATRICES TO BE USED IN X & Y VELOCITY  
C TRANSFORMATIONS, RESPECTIVELY:
```

```
DO 50 I=1,3
```

```
DO 50 J=1,3
```

```
T(I,J) = VF(J,I)
```

```
50 R(I,J) = PV(J,I)
```

```
C ***** OUTPUT STATEMENTS *****  
C ***** MAIN PROGRAM *****
```

```
WRITE(4,110)COUNT,XH,YH,ZH,OMEGA,XV,YV,ZV,ALPHA,ANSER
```

```
WRITE(8,111)COUNT
```

```
DO 60 I=1,3
```

```
60 WRITE(8,112)R(I,1),R(I,2),R(I,3),T(I,1),T(I,2),T(I,3)
```

```

C ***** FORMAT STATEMENTS *****
C ***** MAIN PROGRAM *****

101 FORMAT(D11.5,2X,D11.5)
103 FORMAT(112(' '),/,/,41X,'LASER DOPPLER VELOCIMETER DATA',/,/,
1,112(' '),/,58X,'*',/,27X,'X-Y PLANE',22X,'*',22X,'Y-Z PLANE',
2,/,58X,'*',/,112(' '))
104 FORMAT(58X,'*',/,/,NO.,13X,'TUNNEL LOCATION',14X,'PV ANGLE',
1,4X,'*',15X,'TUNNEL LOCATION',14X,'PV ANGLE',/,58X,'*',/,
2,112(' '))
105 FORMAT(111(' '),/,/,47X,'ROTATION MATRICES',/,/,111(' '))
106 FORMAT(55X,'*',/,23X,'X-Y PLANE',23X,'*',23X,'Y-Z PLANE',
1,55X,'*',/,111(' '))
107 FORMAT(10X)
110 FORMAT(I3,4(2X,D11.5),' *',4(2X,D11.5),5X,D11.5)
111 FORMAT(/,'#',I2,' SET OF COORDINATES',/)
112 FORMAT(4X,3(D13.7,4X),'*',4X,3(D13.7,4X))

GO TO 10

69 CLOSE(2)
CLOSE(4)
CLOSE(6)
CLOSE(8)

END

```

```

C *****
C *
C *
C *
C *
C *****

```

VECTOR

```

C THIS SUBROUTINE FINDS THE VECTOR PATH OF A LASER BEAM
C GIVEN THE COMPONENTS OF THE INCIDENT VECTOR AND THE
C INDICES OF REFRACTION

```

SUBROUTINE VECTOR(NI,NO,X,Y,Z,A,B,C)

DOUBLE PRECISION X,Y,Z,A,B,C,NI,NO,R

R = (NI/NO)

A = DSQRT(1.0D0-((R*R)*(1.0D0-X*X)))

B = R*Y

C = R*Z

END

```

C *****
C *
C *
C *
C *
C *****
          MIRROR
C *****
C THIS SUBROUTINE DETERMINES THE COMPONENTS OF THE REFLECTED
C LASER BEAM VECTORS OFF OF THE MIRROR
          SUBROUTINE MIRROR(F,D1,PHI,THETA,P,L,V,U)
          DOUBLE PRECISION POI(3),F,D1,PHI,THETA,P(7,3),L(7,3),V(8,3),U(8,3)
          1,VD(2),LD(2),DA
          INTEGER I,J,K
          K = 0
          VD(1) = 0.0D0
          VD(2) = 0.0D0
          LD(1) = 0.0D0
          LD(2) = 0.0D0
          DA = DCOS(2.0D0*PHI)
          POI(1) = (F-D1)*(1.0D0+DA)*DCOS(THETA)*DSIN(THETA)
          POI(2) = (F-D1)*(DSIN(THETA)*DSIN(THETA) - DCOS(THETA)*DCOS(THETA)
          1*DA)
          POI(3) = (F-D1)*2.0D0*DCOS(PHI)*DSIN(PHI)*DCOS(THETA)

```

C CALCULATE THE REFLECTED LASER BEAM VECTORS AND THEIR LENGTHS FOR
C NORMALIZATION

```
DO 302 I = 3,4  
  K = K+1  
DO 301 J = 1,3  
  V(I,J) = POI(J)-P(K,J)  
  U(I,J) = FOI(J)-L(K,J)  
  VD(K) = VD(K)+(V(I,J)*V(I,J))  
  LD(K) = LD(K)+(U(I,J)*U(I,J))
```

```
301 CONTINUE  
302 CONTINUE
```

K = 0

C NORMALIZE THE REFLECTED VECTORS

```
DO 304 I = 3,4  
  K = K+1  
DO 303 J = 1,3  
  V(I,J) = V(I,J)/DSORT(VD(K))  
  U(I,J) = U(I,J)/DSORT(LD(K))  
303 CONTINUE  
304 CONTINUE
```

END

```
C *****  
C *  
C *  
C *  
C *  
C *****  
          APART  
C *****  
C *****
```

```
C THIS SUBROUTINE CALCULATES THE EUCLIDEAN DISTANCE BETWEEN TWO  
C POINTS
```

```
      SUBROUTINE APART(A,B,C,I,J,K,ANSER)
```

```
      DOUBLE PRECISION A,B,C,I,J,K,ANSER
```

```
      ANSER = DSORT((A-I)*(A-I)+(B-J)*(B-J)+(C-K)*(C-K))
```

```
      END
```

```

C *****
C *
C *
C *
C *****
C
C THIS SUBROUTINE LOCATES THE POINTS ON THE SKEW LINES WHERE THE
C DISTANCE IS A MINIMUM & CALCULATES THAT DISTANCE
C
SUBROUTINE LOCATE(V1,V2,V3,VX,VY,VZ,P1,P2,P3,PX,PY,PZ,M,COUNT)
DOUBLE PRECISION A,B,C,D,E,S,T,DET,FO(3),FE(3),V1,V2,V3
1,M(3),VX,VY,VZ,P1,P2,P3,PX,PY,PZ
INTEGER I,COUNT
C SET UP THE SYSTEM OF SIMULTANEOUS EQUATIONS TO BE SOLVED
C
C      I A -B I I T I I D I
C      I I I I I I I I I I
C      I C -A I I S I I E I
C
A = V1*VX+V2*VY+V3*VZ
B = V1*V1+V2*V2+V3*V3
C = VX*VX+VY*VY+VZ*VZ
D = -((PX-P1)*V1+(PY-P2)*V2+(PZ-P3)*V3)
E = -((PX-P1)*VX+(PY-P2)*VY+(PZ-P3)*VZ)

```

C USE THE METHOD OF COFACTORS & THE ADJOINT TO DETERMINE THE INVERSE
 C OF THE MATRIX AND SOLVE FOR THE UNKNOWN S & T

```

C      T ! ! ! -A B ! ! D !
C      ! ! ! = --- ! ! ! !
C      ! S ! DET ! -C A ! ! E !
C

```

DET = B*C-A*A

T = (B*E-A*D)/DET
 S = (A*E-C*D)/DET

C SOLVE FOR THE LOCATION OF THE MINIMUM DISTANCE POINTS

PO(1) = P1+S*X1
 PO(2) = P2+S*X2
 PO(3) = P3+S*X3
 PE(1) = FX+T*X
 PE(2) = FY+T*Y
 PE(3) = FZ+T*Z

C CALCULATE THE DISTANCE BETWEEN THEM

A = PO(1)-PE(1)
 B = PO(2)-PE(2)
 C = PO(3)-PE(3)
 D = DSORT(A*A+B*B+C*C)

C CALCULATE THE MIDPOINT OF THE MINIMUM DISTANCE POINTS

DO 901 I = 1,3
 M(I) = (PO(I)+PE(I))/2.0D0
 901 CONTINUE

```
WRITE(6,950)COUNT,(P0(I),I=1,3)
WRITE(6,950)COUNT,(PE(J),J=1,3)
WRITE(6,951)D
```

```
950 FORMAT('(',I2,') LOCATE - ',3(D13.7,2X))
951 FORMAT('***** MINIMUM DISTANCE BETWEEN "CONVERGING" LINES = ',
1,D13.7,')
```

```
END
```

```

C *****
C *
C *
C *
C *
C *****
C THIS SUBROUTINE CALCULATES THE COORDINATE AXES OF THE PROBE
C VOLUME RCCS USING THE NORMAL TO THE PLANE OF VECTORS 7 AND 8
      SUBROUTINE PROBE(X7,Y7,Z7,X8,Y8,Z8,P)
      DOUBLE PRECISION P(3,3),D,A,B,C,X7,Y7,Z7,X8,Y8,Z8
C CALCULATE THE CROSS PRODUCT COMPONENTS OF VECTORS 7 AND 8 TO
C OBTAIN THE NORMAL TO THE PROBE VOLUME
      A = Y8*Z7-Z8*Y7
      B = Z8*X7-X8*Z7
      C = X8*Y7-Y8*X7
      D = DSQRT(A*A+B*B+C*C)
C NORMALIZE THE VECTOR AND SAVE THE VALUES IN THE P MATRIX FOR THE
C Z-AXIS OF THE PROBE VOLUME
      P(3,1) = A/D
      P(3,2) = B/D
      P(3,3) = C/D

```

C DETERMINE THE Y-AXIS OF THE PROBE VOLUME RCCS BY ADDING
C VECTORS V7 AND V8

A = X7+X8
B = Y7+Y8
C = Z7+Z8

D = DSORT(A*+B*B+C*C)

C NORMALIZE THE VECTOR AND SAVE THE VALUES IN THE P MATRIX FOR THE
C Y-AXIS OF THE PROBE VOLUME RCCS

P(2,1) = A/D
P(2,2) = B/D
P(2,3) = C/D

C SOLVE FOR THE X-AXIS OF THE PROBE VOLUME RCCS BY CROSSING THE
C Y-AXIS INTO THE Z-AXIS

A = P(2,2)*P(3,3)-P(2,3)*P(3,2)
B = P(2,3)*P(3,1)-P(2,1)*P(3,3)
C = P(2,1)*P(3,2)-P(2,2)*P(3,1)

D = DSORT(A*+B*B+C*C)

C NORMALIZE THE VECTOR AND SAVE THE VALUES IN THE P MATRIX FOR THE
C X-AXIS OF THE PROBE VOLUME RCCS

P(1,1) = A/D
P(1,2) = B/D
P(1,3) = C/D

END

Appendix C

Tunnel Point to LDV Orientation Program Listing

Program TUNNEL was designed to demonstrate that the angles θ and ϕ can be calculated for four independent mirrors such that the four beams converge to a specified point in the tunnel. The coding of the program assumes that the indices of refraction for outside and inside the tunnel are equal, and each of the laser beams have equal indices of refraction for each medium they encounter. To change either of these assumptions is an easy matter. The distance d_1 is also set at a constant value.

Within the program, various distances are set to user-defined values. The computer code then reads in the tunnel coordinates and transforms them to the mirror coordinate system. The orientation of the device is then calculated and then the fine adjustments to the azimuth and elevation angles for each mirror. Since the focal length of the lens is distorted, the probe volume angles for each pair of laser beams is calculated.

The strength of this computer code lies in the ability to analytically determine the appropriate angles for a mirror such that a beam reflected off of that mirror passes through a given point in the tunnel after traversing the tunnel access window.

PROGRAM TUNNEL

C THIS PROGRAM IS DESIGNED TO DETERMINE THE
C ANGLES OF THE LDV MIRROR SYSTEM GIVEN THE
C LOCATION OF THE POINT IN THE TUNNEL USING
C THE TUNNEL COORDINATE SYSTEM

C PROGRAM CREATED BY:

C CAPT GARY S. KRAJCI
C AIR FORCE INSTITUTE OF TECHNOLOGY
C WRIGHT-PATTERSON AFB OH 45433
C 7 NOVEMBER 1983

C *****
C *
C * DEFINITION OF NOTATION *
C * PROGRAM TUNNEL *
C *
C *****

C ***** TUNNEL/LDV CONFIGURATION *****

C D1 - DISTANCE FROM THE MIRROR (M1) TO THE LDVS (L1)
C D2 - DISTANCE FROM M1 TO THE ORIGIN OF THE TUNNEL RECTANGULAR
C CARTESIAN COORDINATE SYSTEM (MCCS)
C D3 - DISTANCE FROM M1 TO THE ACCESS WINDOW OF THE WIND TUNNEL
C FL - FOCAL LENGTH OF L1
C W - THICKNESS OF THE ACCESS WINDOW OF THE WIND TUNNEL
C S - DISTANCE BETWEEN THE TWO PLANE PARALLEL LASER BEAMS BEFORE THEY
C ENTER L1
C N1,N2 - INDICES OF REFRACTION FOR THE AREAS OUTSIDE/INSIDE THE
C TUNNEL AND IN THE WINDOW, RESPECTIVELY
C - FOR THE GREEN LASER IN THE X-Y PLANE

```

C THETA - ANGLE MADE BY THE DEVICE AND THE X-AXIS OF THE
C DEVICE'S RCCS
C PHI - ANGLE MADE BY THE DEVICE NORMAL AND THE X-Y PLANE
C DELTA - ANGLE MADE BY THE DEVICE NORMAL AND THE X-Z PLANE
C - DELTA = THETA - 90
C TH,PH,DE -- VECTORS CONTAINING THE ANGLES THETA, PHI, AND DELTA
C FOR EACH OF THE FOUR MIRRORS ON THE DEVICE
C TPX,TPY,TPZ - LOCATION OF THE PROBE VOLUME IN THE DEVICE RCCS
C LV,SU,FV - LENGTH AND COMPONENTS OF THE VECTORS EMANATING FROM L1
C ***** X-Y PLANE ANALYSIS *****
C V - ARRAY OF VECTORS USED TO DESCRIBE THE PATHS OF THE LDV LASER
C BEAMS IN THE X-Y PLANE
C PV - ARRAY OF VECTORS USED TO DESCRIBE THE PROBE VOLUME COORDINATE
C SYSTEM
C R - ARRAY OF VECTORS WHICH CONTAINS THE DIRECTIONAL COSINES TO CHANGE
C THE MEASURED VELOCITY IN THE PROBE VOLUME RCCS TO THE MIRROR RCCS
C - K IS THE TRANSPOSE OF THE MATRIX CONTAINING THE VECTORS FV
C OMEGA - ANGLE MADE BY THE TWO CONVERGING LASER BEAMS WHICH CREATE
C THE PROBE VOLUME
C P - ARRAY OF POINTS USED TO DETERMINE THE LOCATION OF THE PROBE
C VOLUME IN THE WIND TUNNEL
C ***** Y-Z PLANE ANALYSIS *****
C U - ARRAY OF VECTORS USED TO DESCRIBE THE PATHS OF THE LDV LASER BEAMS
C IN THE Y-Z PLANE
C VP - ARRAY OF VECTORS USED TO DESCRIBE THE PROBE VOLUME COORDINATE
C SYSTEM
C T - MATRIX OF VECTORS WHICH CONTAINS THE DIRECTIONAL COSINES TO CHANGE
C THE MEASURED VELOCITY IN THE PROBE VOLUME RCCS TO THE MIRROR RCCS
C - T IS THE TRANSPOSE OF THE MATRIX CONTAINING THE VECTORS VP

```

C ALPHA - ANGLE MADE BY THE TWO CONVERGING LASER BEAMS WHICH CREATE
C THE PROBE VOLUME
C L - ARRAY OF POINTS (LOCATIONS) USED TO DETERMINE THE LOCATION OF THE
C PROBE VOLUME IN THE WIND TUNNEL
C ***** TRANSIENT VARIABLES *****
C I,J - INTEGER COUNTERS FOR DO LOOPS
C COUNT - A COUNTER USED TO TRACK THE DIFFERENT ORIENTATIONS OF THE LDV
C MIRROR
C PI - THE VALUE OF PI AS DEFINED BY THE COMPUTER
C CALC - VARIABLE USED IN THE CALCULATION OF THE VERTICLE INTERSECTION
C POINTS ON THE MIRROR
C X1,Y1,Z1 - TRANSIENT VARIABLES FOR THE LOCATION OF THE PROBE
C VOLUME
C C1,C2,C3 - VECTOR TO DESCRIBE THE REFLECTED RAY OFF THE CENTER
C OF THE DEVICE
C - USED TO DETERMINE THE ORIENTATION OF THE DEVICE
C NINETY - THE VALUE OF NINETY DEGREES IN RADIANS
C ***** FILES *****
C FILE 2 - CONTAINS THE INPUT POINT FOR THE PROBING
C FILE 4 - CONTAINS THE OUTPUT DATA:
C (1) THE ANGLES THETA AND PHI FOR THE DEVICE
C (2) THE ANGLES THETA AND PHI FOR EACH MIRROR
C (3) THE PROBE VOLUME ANGLES FOR EACH SET OF RAYS
C FILE 8 - CONTAINS THE ROTATION MATRICES FOR TRANSFORMING THE X & Y
C VELOCITY COMPONENTS FROM THE PROBE VOLUME TO THE
C MIRROR ROCS

```

C *****
C *
C *
C *
C *
C *****
      TUNNEL MAIN PROGRAM
C *****
      DOUBLE PRECISION D1,D2,D3,FL,W,S,THE16,PHI,DELTA,V(2,3)
      1,FV(3,3),OMEGA,N1,N2,P(2,3),R(3,3),F,C1,C2,C3
      DOUBLE PRECISION U(2,3),VF(3,3),ALPHA,I,(2,3)
      1,T(3,3),PI,CALC,TPX,TPY,TPZ,LV,SU,FV
      2,X1,Y1,Z1,TH(4),FH(4),DE(4)
      INTEGER COUNT,I,J
      COMMON/LJVDATA/N1,N2,W
      COMMON/TPPTS/TPX,TPY,TPZ
      DATA D1,D2,D3/3.125D0,26.875D0,2.5D0/
      DATA FL,W,S/30.0D0,0.375D0,1.0D0/
      DATA N1,N2/1.364D0,1.523D0/
      OPEN(2,FILE='INTUN')
      OPEN(4,FILE='OUTTUN')
      OPEN(8,FILE='ROTMAT')
      COUNT = 0
      PI = (4.0D0)*DATAN(1.0D0)
      NINETY = PI/2.0D0
      C READ IN THE TUNNEL LOCATION (TUNNEL ROCS)
      10 READ(2,101,END=69)X1,Y1,Z1
      COUNT = COUNT + 1

```

```

C CONVERT THE TUNNEL POINTS FROM TUNNEL TO DEVICE RCCS

TPX = Y1+D2
TPY = -X1
TPZ = Z1

C ***** LDV MIRROR ANALYSIS *****
C NORMALIZE THE LASER BEAMS WHICH EMANATE FROM L1 ON THEIR
C WAY TO THE MIRRORS

LV = DSQRT((S*S)/4.0D0+(FL*FL))
SV = S/(2.0D0*LV)
FV = FL/LV

C DETERMINE THE ORIENTATION OF THE MIRROR DEVICE

CALL FIND(0.0D0,0.0D0,0.0D0,C1,C2,C3)
CALL ANGLE(0.0D0,1.0D0,0.0D0,C1,C2,C3,THETA,PHI,DELTA)

C COMPUTE THE LOCATION OF THE POINTS MADE BY THE LASER BEAMS
C ON THE MIRRORS IN THE DEVICE RCCS

P(1,1) = (S*(FL-D1))/((S*D(TAN(THETA)))-(2.0D0*FL))
P(1,2) = P(1,1)*D(TAN(THETA))
P(1,3) = 0.0D0

P(2,1) = (S*(FL-D1))/((S*D(TAN(THETA)))+(2.0D0*FL))
P(2,2) = P(2,1)*D(TAN(THETA))
P(2,3) = 0.0D0

```

CALC = 2.000*FL*DCOS(PHI)*SIN(DELTA)

L(1,1) = 0.000

L(1,2) = (S*(D1-FL)*SIN(PHI))/(CALC-S*DCOS(PHI))

L(1,3) = (S*(FL-L(1,2)-D1))/(2.000*FL)

L(2,1) = 0.000

L(2,2) = (S*(FL-D1)*SIN(PHI))/(CALC+S*DCOS(PHI))

L(2,3) = (S*(D1+L(2,2)-FL))/(2.000*FL)

C DETERMINE THE COMPONENTS OF THE REFLECTED LASER BEAMS OFF
C THE MIRRORS ON THEIR WAY TO THE WINDOW

CALL FIND(P(1,1),P(1,2),P(1,3),V(1,1),V(1,2),V(1,3))

CALL FIND(P(2,1),P(2,2),P(2,3),V(2,1),V(2,2),V(2,3))

CALL FIND(L(1,1),L(1,2),L(1,3),U(1,1),U(1,2),U(1,3))

CALL FIND(L(2,1),L(2,2),L(2,3),U(2,1),U(2,2),U(2,3))

C DETERMINE THE ANGLES THETA, PHI, AND DELTA OF THE INDIVIDUAL
C MIRRORS ON THE DEVICE

CALL ANGLE(SV,FV,0.000,V(1,1),V(1,2),V(1,3),IH(1),PH(1),DE(1))

CALL ANGLE(-SV,FV,0.000,V(2,1),V(2,2),V(2,3),TH(2),PH(2),DE(2))

CALL ANGLE(0.000,FV,-SV,U(1,1),U(1,2),U(1,3),TH(3),PH(3),DE(3))

CALL ANGLE(0.000,FV,SV,U(2,1),U(2,2),U(2,3),TH(4),PH(4),DE(4))

```

C ***** ORIENTATION OF PROBE VOLUME *****
C COMPUTE THE THE ANGLES ALPHA & OMEGA
      ALPHA = DACOS((U(1,1)*U(2,1))+U(1,2)*U(2,2))/(U(1,3)*U(2,3))
      OMEGA = DACOS((V(1,1)*V(2,1))+V(1,2)*V(2,2))/(V(1,3)*V(2,3))
C COMPUTE THE X,Y,Z AXES OF THE PROBE VOLUME
      CALL PROBE(U(1,1),V(1,2),V(1,3),V(2,1),V(2,2),V(2,3),PV)
      CALL PROBE(U(1,1),U(1,2),U(1,3),U(2,1),U(2,2),U(2,3),VP)
C TRANSPOSE THE MATRICES PV AND VP, THE NORMALIZED COORDINATE AXES OF
C THE PROBE VOLUMES, TO OBTAIN THE MATRICES R AND T, WHICH ARE THE
C DIRECTIONAL COSINE ROTATION MATRICES TO BE USED IN X & Y VELOCITY
C TRANSFORMATIONS, RESPECTIVELY:
      DO 50 I=1,3
      DO 50 J=1,3
      T(I,J) = VP(J,I)
      50 R(I,J) = PV(J,I)
C ***** OUTPUT STATEMENTS *****
C ***** MAIN PROGRAM *****
      WRITE(4,110)COUNT,THETA,PHI,OMEGA,ALPHA
      WRITE(8,111)COUNT
      DO 60 I=1,3
      60 WRITE(8,112)R(I,1),R(I,2),R(I,3),T(I,1),T(I,2),T(I,3)
      DO 61 I=1,4
      61 WRITE(4,113)I,TH(I),PH(I)

```

```

C ***** FORMAT STATEMENTS *****
C ***** MAIN PROGRAM *****
101 FORMAT(3(D13.7,2X))
110 FORMAT(/,/,I1,1X,'-- DEVICE DATA: THETA = ',D13.7,2X,'PHI = ',
1,D13.7,/,', PROBE VOLUME ANGLES: (H) ',D13.7,2X, '(U) ',D13.7
2,/,', MIRROR DATA: ')
111 FORMAT(/,/,#,12,' SET OF COORDINATES',/,)
112 FORMAT(4X,3(D13.7,4X),*,4X,3(D13.7,4X))
113 FORMAT(/,5X,('(,12,') THETA = ',D13.7,2X,'PHI = ',D13.7)

GO TO 10

69 CLOSE(2)
CLOSE(4)
CLOSE(8)

END

```

C DETERMINE THE Y-AXIS OF THE PROBE VOLUME RCLS BY ADDING V7 AND V8

A = X7+X8
B = Y7+Y8
C = Z7+Z8

D = DSQRT(A*A+B*B+C*C)

C NORMALIZE THE VECTOR AND SAVE THE VALUES IN THE P MATRIX FOR THE
C Y COMPONENT OF THE PROBE VOLUME RCLS

P(2,1) = A/D
P(2,2) = B/D
P(2,3) = C/D

C SOLVE FOR THE X-AXIS OF THE PROBE VOLUME RCLS BY CROSSING THE
C Y-AXIS INTO THE Z-AXIS

A = P(2,2)*P(3,3)-P(2,3)*P(3,2)
B = P(2,3)*P(3,1)-P(2,1)*P(3,3)
C = P(2,1)*P(3,2)-P(2,2)*P(3,1)

D = DSQRT(A*A+B*B+C*C)

C NORMALIZE THE VECTOR AND SAVE THE VALUES IN THE P MATRIX FOR THE
C X COMPONENT OF THE PROBE VOLUME RCLS

P(1,1) = A/D
P(1,2) = B/D
P(1,3) = C/D

END

```

C *****
C *
C *
C *
C *
C *****
C THIS SUBROUTINE DETERMINES THE COMPONENTS OF THE REFLECTED
C VECTOR GIVEN THE POINT ON THE MIRROR AND THE POINT IN THE
C TUNNEL
      SUBROUTINE FIND(M1,M2,M3,A1,A2,A3)
      DOUBLE PRECISION F,EPS,EPS2,ETA,X(1),X1,Y1,Z1,TPX,TPY,TPZ,A
      +,B,C,D,N1,N2,W,A1,A2,A3,SR,K,M1,M2,M3
      INTEGER NSIG,N,ITMAX,IER
      EXTERNAL F
      COMMON/LIDDATA/N1,N2,W
      COMMON/FIDATA/X1,Y1,Z1
      COMMON/TPTS/TPX,TPY,TPZ
      X1 = M1
      Y1 = M2
      Z1 = M3
      C INITIALIZE THE ARGUMENTS FOR ZREAL2
      EPS = 1.0D-16
      EPS2 = 1.0D-16
      ETA = 1.0D-8
      NSIG = 5
      ITMAX = 100
      N = 1

```

```

C CALCULATE A GOOD INITIAL GUESS FOR THE VECTOR'S COMPONENTS
C WHICH WILL BE THE VALUES FOR THE DIRECTED VECTOR BETWEEN
C THE MIRROR AND TUNNEL POINTS

```

```

A = TPX-X1
B = TPY-Y1
C = TPZ-Z1

```

```

D = DSQRT(A**2+B**2+C**2)

```

```

X(1) = A/D

```

```

C *****
C *
C * NOTE: ZREAL2 IS AN IMSL ROUTINE WHOSE PURPOSE *
C * IS TO FIND THE REAL ZEROS OF A REAL FUNCTION *
C * WHEN THE INITIAL GUESS IS GOOD. *
C *
C *****

```

```

CALL ZREAL2(F,EFS,EFS2,ETA,NSIG,N,X,I,IMAX,JEK)

```

```

C CALCULATE THE Y- AND Z-COMPONENTS OF THE REFLECTED VECTOR

```

```

K = N1/N2
SR = DSQRT(1.000-K**2)
D = ((TPY-X1-W)/X(1))*K**2/SR
A1 = X(1)
A2 = B/D
A3 = C/D

```

C BECAUSE ZREAL2 ONLY CALCULATES X TO THE VALUE SPECIFIED IN
C THE ARGUMENTS, THE CALCULATED VALUE HAS THE CORRECT DIRECTION
C BUT DOES NOT HAVE UNIT MAGNITUDE. THEREFORE, TO CALCULATE
C THE CORRECT ANGLES, THE RESULT MUST BE NORMALIZED

D = DSQRT(A1*A1+A2*A2+A3*A3)

A1 = A1/D

A2 = A2/D

A3 = A3/D

END

```

C *****
C *
C *
C *
C *
C *****

```

```

C THIS SUBROUTINE DETERMINES THE NORMAL TO THE WINDOW GIVEN
C THE COMPONENTS OF THE NORMALIZED INCIDENT AND REFLECTED
C RAYS AND THEN DETERMINES THE ANGLES THETA & PHI

```

```

SUBROUTINE ANGLE(V1,V2,V3,VX,VY,VZ,THETA,PHI,DELTA)
DOUBLE PRECISION V1,V2,V3,VX,VY,VZ,NINETY,THETA,PHI,DELTA,L
+,N1,N2,N3

```

```

NINETY = 2.0D0/DATAN(1.0D0)

```

```

C SUBTRACT THE INCIDENT RAY FROM THE REFRACTED RAY AND
C NORMALIZE THE RESULT TO OBTAIN THE UNIT NORMAL TO THE
C MIRROR

```

```

N1 = VX-V1
N2 = VY-V2
N3 = VZ-V3

```

```

L = DSORT(N1*N1+N2*N2+N3*N3)

```

```

N1 = N1/L
N2 = N2/L
N3 = N3/L

```

C GIVEN THE UNIT NORMAL TO THE MIRROR, CALCULATE THE ANGLES PHI,
C DELTA, AND THETA BASED ON THE EQUATIONS FOR TRANSFORMING FROM
C SPHERICAL TO RECTANGULAR COORDINATES

C
C X = COS(DELTA)COS(PHI)
C Y = COS(DELTA)SIN(PHI)
C Z = SIN(DELTA)

C AND THE FACT THAT

C DELTA = THETA - 90

PHI = DASIN(N3)
DELTA = DASIN(N2/USORT(1.010-N3*N3))
THETA = DELTA+INETY

END

VITA

Gary Stephen Krajci was born on 7 April 1955 in Canton, Ohio. He graduated from Perry High School in Massillon, Ohio in 1973 and, attended Bowling Green State University, Bowling Green, Ohio from which he received a Bachelor of Science in Mathematics in June 1977. He received his commission from AFROTC and entered the Air Force on active duty in September 1977. He completed communications-electronics training in May 1978 at Keesler AFB, Mississippi. He served as a Combat Crew Communications Officer with the 1960th Communications Squadron at Pease AFB, New Hampshire, Communications Staff Officer with the 2146th Communications Group at Osan AB, Republic of Korea, and a Project Officer working on the nuclear survivability of communications with the Air Force Weapons Laboratory at Kirland AFB, New Mexico. There, he coauthored a technical report entitled The Performance of an EHF Satellite Communications Link in a Scintillated Environment. He then entered the School of Engineering, Air Force Institute of Technology, in June 1982.

Permanent address: 4944 4th Street N.W.
Canton, Ohio 44708

UNCLASSIFIED

SECURITY CLASSIFICATION OF THIS PAGE

REPORT DOCUMENTATION PAGE

| | | | |
|--|-------|--|----------------------|
| 1a. REPORT SECURITY CLASSIFICATION Unclassified | | 1b. RESTRICTIVE MARKINGS | |
| 2a. SECURITY CLASSIFICATION AUTHORITY | | 3. DISTRIBUTION/AVAILABILITY OF REPORT Approved for public release; distribution unlimited | |
| 2b. DECLASSIFICATION/DOWNGRADING SCHEDULE | | 4. PERFORMING ORGANIZATION REPORT NUMBER(S) AFIT/GSO/MA/83D-2 | |
| 5. MONITORING ORGANIZATION REPORT NUMBER(S) | | 6a. NAME OF PERFORMING ORGANIZATION School of Engineering AF Institute of Technology | |
| 6b. OFFICE SYMBOL (If applicable) AFIT/EN | | 7a. NAME OF MONITORING ORGANIZATION | |
| 6c. ADDRESS (City, State and ZIP Code) Wright-Patterson AFB, Ohio 45433 | | 7b. ADDRESS (City, State and ZIP Code) | |
| 8a. NAME OF FUNDING/SPONSORING ORGANIZATION Arnold Engineering & Development Center | | 8b. OFFICE SYMBOL (If applicable) DOTS | |
| 9. PROCUREMENT INSTRUMENT IDENTIFICATION NUMBER | | 8c. ADDRESS (City, State and ZIP Code) Arnold AFS, Tennessee 37389 | |
| 10. SOURCE OF FUNDING NOS. | | 11. TITLE (Include Security Classification) See Box 19 | |
| PROGRAM ELEMENT NO. | | PROJECT NO. | |
| TASK NO. | | WORK UN NO. | |
| 12. PERSONAL AUTHOR(S) Gary S. Krajci, B.S., Capt, USAF | | 13a. TYPE OF REPORT Thesis | |
| 13b. TIME COVERED FROM _____ TO _____ | | 14. DATE OF REPORT (Yr., Mo., Day) 1983 December | |
| 15. PAGE COUNT 126 | | 16. SUPPLEMENTARY NOTATION Approved for Public Release - IRW APR 1984 Lynn E. WOLAVER Dean for Education and Professional Development Air Force Institute of Technology (AFIT) | |
| 17. COSATI CODES | | 18. SUBJECT TERMS (Continue on reverse if necessary and identify by block number) | |
| FIELD | GROUP | SUB. GR. | Velocimeters |
| 17 | 08 | | Laser Velocimeters |
| 12 | 01 | | Velocity Measurement |
| 19. ABSTRACT (Continue on reverse if necessary and identify by block number) Title: LASER VELOCIMETER OPTICAL TRAVERSE SCHEME: AN INVESTIGATION OF A PROPOSED OPTIC SCANNING TECHNIQUE FOR ARNOLD ENGINEERING AND DEVELOPMENT CENTER'S FOUR-FOOT TRANSONIC WIND TUNNEL Thesis Chairman: Richard W. Kulp, LtCol, USAF | | | |
| 20. DISTRIBUTION/AVAILABILITY OF ABSTRACT UNCLASSIFIED/UNLIMITED <input checked="" type="checkbox"/> SAME AS RPT. <input type="checkbox"/> DTIC USERS <input type="checkbox"/> | | 21. ABSTRACT SECURITY CLASSIFICATION Unclassified | |
| 22a. NAME OF RESPONSIBLE INDIVIDUAL Richard W. Kulp, LtCol, USAF | | 22b. TELEPHONE NUMBER (Include Area Code) 513-255-2915 | |
| 22c. OFFICE SYMBOL AFIT/ENC | | | |

DD FORM 1473, 83 APR

EDITION OF 1 JAN 73 IS OBSOLETE.

UNCLASSIFIED
SECURITY CLASSIFICATION OF THIS PAGE

This investigation analyzed a nonstandard laser velocimeter setup proposed for use in AEDC Wind Tunnel 4T. The setup uses a gimbaled mirror to move the probe volume from point to point, and the translation of a lens to control the distance in the tunnel the probe volume reaches.

Results show that for equal indices of refraction inside and outside the tunnel, the laser beams of a converging pair do not totally converge with its associated beam except under certain conditions, and the probe volumes created by each pair of overlapping laser beams do not always coincide. This work then provides the conditions necessary for total convergence of a pair of laser beams for this setup.

A solution is then proposed to insure convergence of each laser beam pair and overlap of the two probe volumes. More than a solution to the above problems, a method is given to determine the azimuth and elevation angles for a mirror such that the reflected beam off the mirror passes through a given point in the tunnel after traversing a window.

To carry out these investigations, a computer code was written to simulate the non-standard laser velocimeter setup, and a second code was written to determine the azimuth and elevation angles for a mirror such that the reflected beam off the mirror passes through a given point in the tunnel after traversing a window. Both codes were written in FORTRAN 77, implemented on a CDC 6000 - CYBER 74, and listed in the report.