

HD-A138 315 SLD TRADE STUDY CANISTER/STS MOUNTING(U) NAVAL RESEARCH 1/1
LAB WASHINGTON DC SPACE SYSTEMS DIV 15 SEP 81

UNCLASSIFIED

F/G 13/4

NL



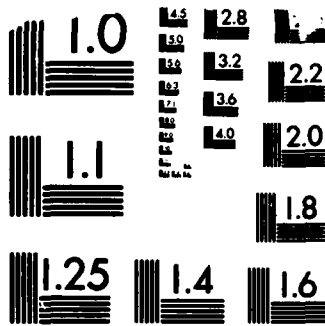

MICROCOPY RESOLUTION TEST CHART
 NATIONAL BUREAU OF STANDARDS-1963-A

NAVAL RESEARCH LABORATORY

SPACE
SYSTEMS
DIVISION

SLD TRADE STUDY

CANISTER/STS MOUNTING

DATE: 15 SEPTEMBER 1981

NO. SSD-D-SD010

APPROVED FOR PUBLIC RELEASE
DISTRIBUTION UNLIMITED



AD A138315

DTIC FILE COPY

DTIC
FEB 27 1984
S A

4555 Overlook Avenue, S.W.
Washington, D.C. 20375

2.0

REQUIREMENT DEFINITION

The mounting configuration is to be designed to meet the following criteria:

2.1

To be capable of mounting in a maximum of shuttle bay locations.

2.2

To use the standard five point, seven degree of reaction support system.

2.3

To use standard shuttle interface hardware.

2.4

To contain and support the necessary deployment mechanisms.

3.0

TRADE STUDY OBJECTIVE

The objective of this trade study is to determine the optimum pin location and degree of restraint for each support. Consideration is to be given to optimization by weight of the support structure, flexibility in mounting locations and simplicity of deployment mechanism. The design criteria to be used is that supplied by Rockwell International.

TRADE-OFF DESCRIPTION AND RESULTS

The standard five point shuttle mounting scheme provides for the following degrees of restraint: Z-direction support at each of the four trunnions, X-direction support at two of the trunnions and Y-direction support at the keel fitting. It was quickly established that the trunnion reactions should be placed as far apart as possible, (i.e., at each end of the canister) since this provides the largest moment arm and thus the smallest Z loading. The X supports should then be placed in the same plane, (i.e., both at the front ring or both at the rear ring of the canister) since this condition provides symmetric and thus stable support. The keel fitting should be located nearest the combined C.G. location to provide a minimum Y overturning moment. These initial observations lead to investigating the following two configurations.

4.1

Configuration No. 1

The first configuration investigated provided the maximum degrees of support at the SLD/Canister interface ring as in Fig. 1. This established X and Z restraint at the two trunnion locations and Y restraint at the keel fitting. The two rear trunnions each provided a Z restraint. This configuration took out maximum load closest to the combined C.G. location and used the rear trunnions for stabilization. The overall load distribution and structural flexibility of this support system proved to be adequate. However, when considering flexibility of shuttle bay location and the required tilt mechanism this configuration possessed several problems. Since the X-load carrying capability of the shuttle longerons increases toward the rear of the bay, it would be more sensible to resist X-loads at the aft rather than forward canister ring. In addition, when considering the forward canister ring (i.e., SLD interface) it is the one which must be deployed out of the shuttle

bay for SLD separation and requires the point of rotation to be at the rear trunnion. Therefore, to preclude an EVA to alter the locking of the shuttle trunnion fittings the pinned trunnion should be on the aft ring.

4.2

Configuration No. 2

For the reasons stated above the second configuration, shown in Fig. 2 was considered. This configuration provided an adequate support load distribution and since the canister is very stiff in the axial direction very little reduction in support stiffness was observed.

5.0

CONCLUSION

Configuration No. 2 was selected as the baseline support mounting scheme for the following reasons:

- a maximum number of shuttle bay mounting locations is provided.
- rotation can take place about the pinned trunnion.
- the preferred deployment direction (over the shuttle nose) is obtained.

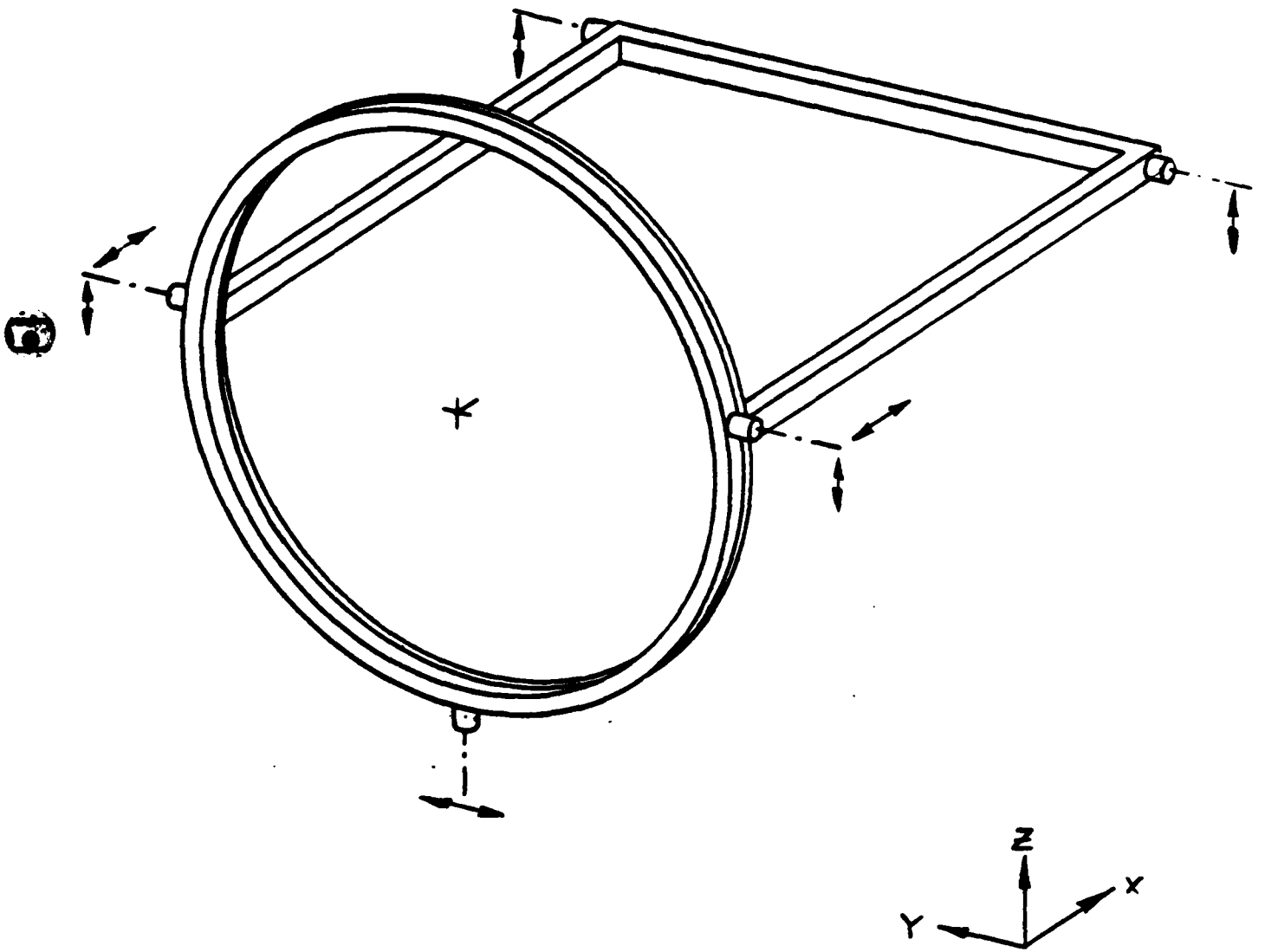

CONFIGURATION 1

FIG. 1

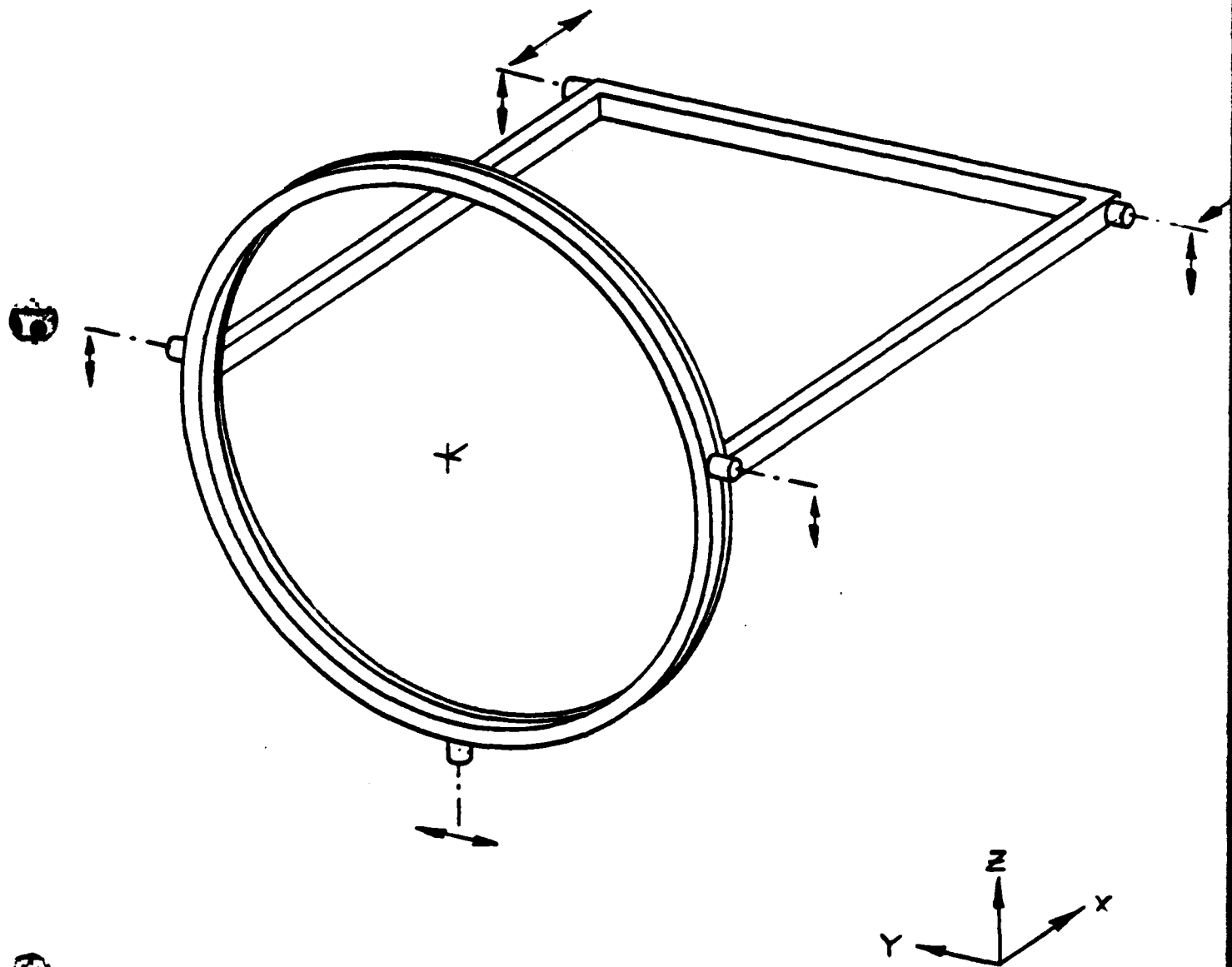

CONFIGURATION 2

FIG. 2

FILM
4-8