

MICROCOPY RESOLUTION TEST CHART  
NATIONAL BUREAU OF STANDARDS-1963-A

2

# NAVAL POSTGRADUATE SCHOOL Monterey, California

ADA138469



## THESIS

THE APPLICATION OF SECURITY CONCEPTS  
TO THE PERSONNEL DATABASE FOR  
THE INDONESIAN NAVY

by

Mulyo Wibiscno

September 1983

Thesis Advisor:

Norman R. Lyons

Approved for public release; distribution unlimited

DTIC FILE COPY

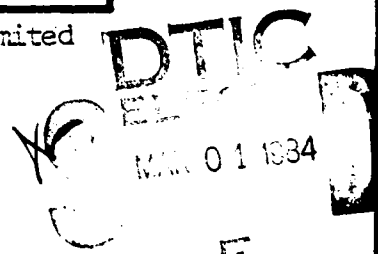

84 03 01 0011

UNCLASSIFIED

SECURITY CLASSIFICATION OF THIS PAGE (When Data Entered)

REPORT DOCUMENTATION PAGE		READ INSTRUCTIONS BEFORE COMPLETING FORM
1. REPORT NUMBER	2. GOVT ACCESSION NO. AD-4138469	3. RECIPIENT'S CATALOG NUMBER
4. TITLE (and Subtitle) THE APPLICATION OF SECURITY CONCEPTS TO THE PERSONNEL DATABASE FOR THE INDONESIAN NAVY		5. TYPE OF REPORT & PERIOD COVERED MASTER'S THESIS: SEPTEMBER 1983
		6. PERFORMING ORG. REPORT NUMBER
7. AUTHOR(s) MULYO WIBISONO		8. CONTRACT OR GRANT NUMBER(s)
9. PERFORMING ORGANIZATION NAME AND ADDRESS NAVAL POSTGRADUATE SCHOOL MONTEREY, CA 93943		10. PROGRAM ELEMENT, PROJECT, TASK AREA & WORK UNIT NUMBERS
11. CONTROLLING OFFICE NAME AND ADDRESS NAVAL POSTGRADUATE SCHOOL MONTEREY, CA 93943		12. REPORT DATE SEPTEMBER 1983
		13. NUMBER OF PAGES 75
14. MONITORING AGENCY NAME & ADDRESS (if different from Controlling Office)		15. SECURITY CLASS. (of this report) UNCLASSIFIED
		15a. DECLASSIFICATION/ DOWNGRADING SCHEDULE
16. DISTRIBUTION STATEMENT (of this Report)  Approved for public release; distribution unlimited		
17. DISTRIBUTION STATEMENT (of the abstract entered in Block 20, if different from Report)		
18. SUPPLEMENTARY NOTES		
19. KEY WORDS (Continue on reverse side if necessary and identify by block number)  Database Security Computer Security Multics Concepts Personnel Database		
20. ABSTRACT (Continue on reverse side if necessary and identify by block number)  This thesis is a continuation of the study work done by Moedjiono ( M.S. thesis, Naval Postgraduate School, 1982 ) concerning personnel database in the Indonesian Navy. ◯ It discusses the current database security and the concept of Multics (Multiplexed Information and Computing System) to propose a personnel database security model in the Indonesian Navy.		

DD FORM 1 JAN 73 1473

EDITION OF 1 NOV 68 IS OBSOLETE  
S/N 0102-LF-014-6601

UNCLASSIFIED

1 SECURITY CLASSIFICATION OF THIS PAGE (When Data Entered)

Approved for public release; distribution unlimited.

The Application of Security Concepts  
to the Personnel Database for  
the Indonesian Navy

by

Mulyo Wibisono  
Lieutenant Commander, Indonesian Navy  
B.S., Indonesian Naval Academy, 1967

Submitted in partial fulfillment of the  
requirements for the degree of

MASTER OF SCIENCE IN MANAGEMENT

from the

NAVAL POSTGRADUATE SCHOOL  
September 1967

Author:



Approved by:



Thesis Advisor



Second Reader

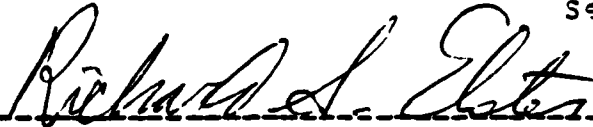

Chairman, Department of Administrative Science

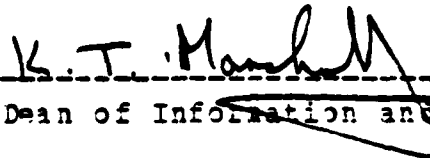

Dean of Information and Policy Sciences

**ABSTRACT**

This thesis is a continuation of the study work done by Moedjicno ( M.S. thesis, Naval Postgraduate School, 1982 ) concerning personnel database in the Indonesian Navy.

It discusses the current database security and the concept of Multics (Multiplexed Information and Computing System) to propose a personnel database security model in the Indonesian Navy.

Accession For	
NTIS GRA&I	<input checked="" type="checkbox"/>
DTIC TAB	<input type="checkbox"/>
Unannounced	<input type="checkbox"/>
Justification	
By	
Distribution/	
Availability Codes	
Dist	Avail and/or Special
A-1	



## TABLE OF CONTENTS

I.	INTRODUCTION . . . . .	9
II.	THE CURRENT PROPOSED PERSONNEL DATABASE SYSTEM . .	12
	A. STATIC DATA ELEMENTS . . . . .	12
	B. DYNAMIC DATA ELEMENTS. . . . .	13
III.	THE NEED FOR SECURITY PROTECTION . . . . .	15
	A. GENERAL APPROACH . . . . .	15
	B. DEFINITIONS . . . . .	17
	C. SECURITY THREATS . . . . .	17
	D. SECURITY PROCEDURES AND MECHANISMS . . . . .	19
	E. SECURITY POLICIES . . . . .	19
	F. MULTILEVEL MODEL . . . . .	22
	1. Requirements to Read Data from a Data Set . . . . .	24
	2. Requirement to Write Data into a Data Set . . . . .	25
IV.	THE MULTICS CONCEPTS . . . . .	26
	A. GENERAL CONCEPT . . . . .	26
	B. ACCESS CONTROL AND PROTECTION . . . . .	26
	1. Per-segment Access Control . . . . .	26
	2. Concentric Rings of Protection . . . . .	27
	C. MULTICS FILE SYSTEM . . . . .	29
	1. Directory Structure . . . . .	30
	2. Elements of a Secure Multics . . . . .	34
	3. Retrieving File-branch Information . . . . .	36
V.	IMPLEMENTATION OF MULTICS IN DATABASE SECURITY . .	38

VI. CONCLUSIONS AND RECOMMENDATIONS . . . . .	42
APPENDIX A: DATABASE PERSONNEL TABLES . . . . .	43
APPENDIX B: DATABASE DICTIONARY . . . . .	54
APPENDIX C: NEW DATABASE DICTIONARY . . . . .	64
LIST OF REFERENCES . . . . .	73
INITIAL DISTRIBUTION LIST . . . . .	75

LIST OF TABLES

I. Access Table . . . . . 39

## LIST OF FIGURES

3.1	Problem Description . . . . .	16
3.2	Security Threats . . . . .	18
3.3	Access-type-dependent Access Control . . . . .	20
3.4	Combination of Compartment and Levels . . . . .	21
3.5	Ordering of Security Level . . . . .	23
3.6	Elements of the Multilevel Model . . . . .	24
4.1	Segment Privileges . . . . .	28
4.2	Conceptual Model of the File-system Tree Structure . . . . .	31
4.3	Interpretation of Links . . . . .	33
4.4	Data Structure of an ACL for an Individual Branch . . . . .	34
4.5	Multics Hierarchy Equivalent . . . . .	35
4.6	Chain of Links . . . . .	36

### ACKNOWLEDGEMENT

The author would like to acknowledge Professor Norman R. Lyons and Professor Daniel R Dolk in supervising this thesis research; and the support of the 1st OJT team from the Indonesian Navy in the Naval Postgraduate School.

## I. INTRODUCTION

This thesis is a continuation of the thesis " The Preliminary Personnel Data Base Design for the Indonesian Navy ", by Moedjiono at the Naval Postgraduate School, Monterey, California, June 1982.

Since 1977, the Indonesian Navy Data Center (DISPULAHTAL) has collected and processed personnel data to support the leadership in the Navy in their decision making. In 1980 work began on the design of personnel database system. Computerization of personnel data took place only within the Department of Personnel and was limited to administrative purposes. However, other departments in the Navy, such as Intelligence, Operations, Logistics, and Planning, had to work with an increasing and more complex amount of data. With every department maintaining its own personnel data there were discrepancies. Information was often incomplete or uniformly updated, since not all departments received data changes. The increasing availability of data, and the importance of timely decision-making emphasized the need to establish a computer system which could accommodate these needs.

Since information is a recognized source of economic value, the data which comprise the information should be secured adequately. E. B. Fernandez [Ref. 5] defines information as:

a critical resource in today's enterprises, whether they are industrial, commercial, educational, or civic.

Information has been widely recognized as a resource of economic value to an enterprise.

This thesis proposes to continue the design work of a personnel database system begun in 1980.

As the use of computers increases, the number of people who might have access to confidential information also increases, emphasizing the importance of access security. In the military, a leakage of information could endanger national security. Data on secret weapons, numbers and distribution of personnel, emergency procedures, and personnel background are important to the enemy. Internally, misuse of data may result in corruption of totals of data in compiling salary lists or theft of secret information for use by the enemy. The absence of any type of data protection may lead to unintentional errors by an operator resulting in the destruction or damage of data. Natural disasters also may destroy information or data. Damaged information may lead to inaccurate decisions, which may jeopardize national security.

To prevent the above mentioned problems, it is essential to provide protective mechanisms to database systems. In other words, there is a need for database security.

In view of the developments of personnel database in the Indonesian Navy and the absence of protective mechanisms, this thesis propose a concept to provide security for data that will be the basis for decisions made by the leadership of the Navy.

There are many varieties of database types, but this thesis will be limited to the security of personnel database. The six sections of this thesis are:

- I. Introduction.
- II. The current proposed personnel database systems
- III. The needs for security protection.
- IV. The Multics concepts.

V. Implementation of Multics in database security.

VI. Conclusions and Recommendations.

This personnel database security concept will be a contribution to the security of computerized data processing in the Indonesian Navy.

## II. THE CURRENT PROPOSED PERSONNEL DATABASE SYSTEM

The present Database systems [Ref. 3] have the following objectives:

- Reducing redundancy
- Sharing of data
- Avoiding inconsistency
- Enforcing standards
- Maintaining integrity, and
- Balancing of conflicting requirements.

This database contains 97 data elements divided into two [Ref. 10] basic groups:

1. Static data elements.
2. Dynamic data elements.

### A. STATIC DATA ELEMENTS

Static data elements consist of data that will not change frequently.

For example:

Main Identification constitutes a group by itself containing the elements numbered 101 to 108. Data elements rarely retrieved by applications programs are entered into Personnel Characteristic (element # 200) which in turn are divided into the following four sub-groups:

1. Marriage subgroup (element # 300) containing elements numbered 301 and 302.
2. Address subgroup (element # 400) containing elements numbered 401 to 403 .

3. Body characteristic subgroup (element # 500) containing elements numbered 501 to 511.
4. Category and Status subgroup (element # 600) containing elements numbered 601 to 607.

#### B. DYNAMIC DATA ELEMENTS.

Dynamic data elements are those which are frequently changed. They are divided into several subgroups corresponding to their historical data. These groups include:

1. Rank group (element # 700) containing elements numbered 701 to 707.
2. Profession group (element # 800) containing elements numbered 801 to 810.
3. Education group (element # 900) containing elements numbered 901 to 909.
4. Education group (element # 1100) containing elements numbered 1101 to 1106. This group is divided into two subgroups:
  - a. Activity and profession subgroup (element # 1200) containing elements numbered 1201 to 1204.
  - b. Family education subgroup (element # 1300) containing elements numbered 1301 to 1303.
5. Payroll group (element # 1400) containing elements numbered 1401 to 1414.
6. Security group (element # 1500) containing elements numbered 1501 to 1506. This group is divided into the following two (2) subgroups:
  - a. Who involved subgroup (element # 1600) containing elements numbered 1601 to 1603.
  - b. Measures subgroup (element # 1700) containing element numbered 1701 to 1703.

(For complete overview of element numbering see Appendix A.)

The above database system forms a hierarchy as illustrated in the model below:

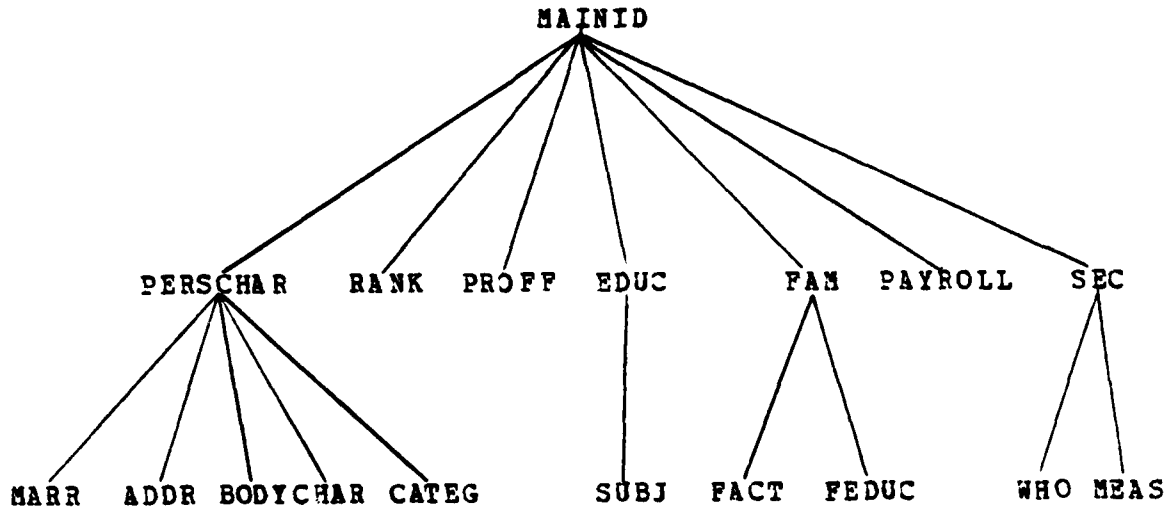

### III. THE NEED FOR SECURITY PROTECTION

#### A. GENERAL APPROACH

The use of automated data processing equipment has become widespread because it permits the handling and storage of vast amounts of information at an affordable cost.

The military benefits from the use of computers include speed and accuracy of data collection which results in timely and improved decisions. Beside these advantages a new hard-to-solve problem emerges, that of information security.

The basic problem is illustrated in Figure 3.1 Users and data at various security levels desire simultaneous access to the machine's resources.

Data with all security levels are stored on the system. Users with proper security credentials are granted data accesses. Navy security policy requires that an individual must possess the required non-discretionary<sup>1</sup> and discretionary<sup>2</sup> privileges before being granted access to the information.

In fact, application of computers in Indonesia is new, so careful considerations should accompany the design and implementation of the basic concepts of database security.

-----  
<sup>1</sup>Non-discretionary security requires that the individual has a security clearance of higher or equal level than the level of the information requested.

<sup>2</sup>Discretionary security requires that the individual possesses a proper need-to-know for requested information

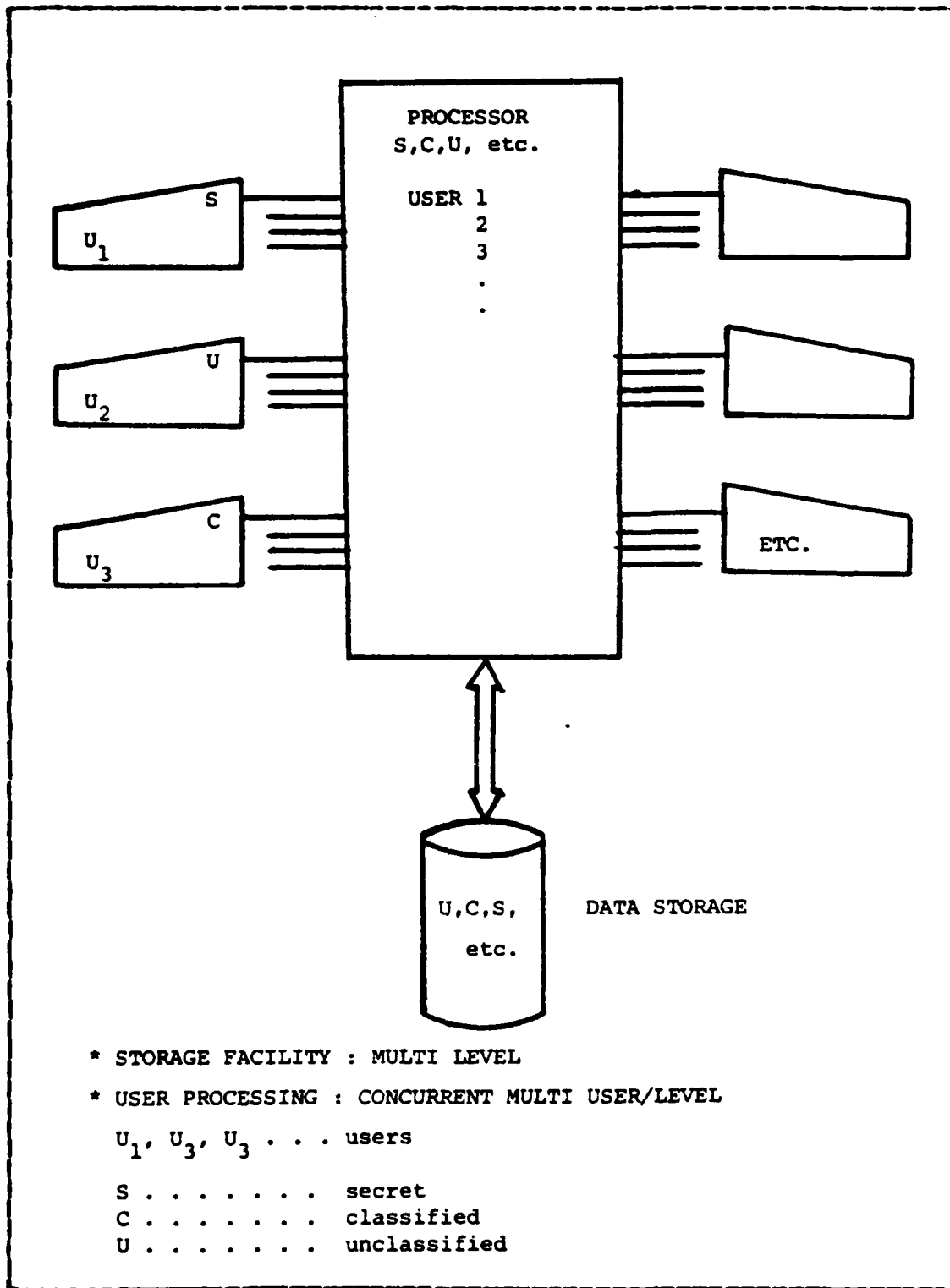

Figure 3.1 Problem Description.

Frequent foul play often takes place because of the lack of protection when using computer systems, as well as protection of the database systems.

In the military, particularly, information is very important. Leakage or corruption of military information could endanger national security. Information about secret weapons, numbers and distribution of personnel, emergency procedures, and personnel background /data are all very important to the enemy. On the other hand, for authorized users updated data is very important since an error in the data may produce faulty decisions.

## B. DEFINITIONS

Many definitions are used in database security. The most widely used definitions according to Fernandez E.B. (1981) [Ref. 5] are:

" Information security is the protection of information against unauthorized disclosure, alteration, or destruction."

" Database security is the protection of information that is maintained in a database."

## C. SECURITY THREATS

A database security violation may take form as unauthorized reading, modification, or destruction of information stored in the database. Possible threats to the security of a computer system may be broadly classified as either malicious or accidental acts.

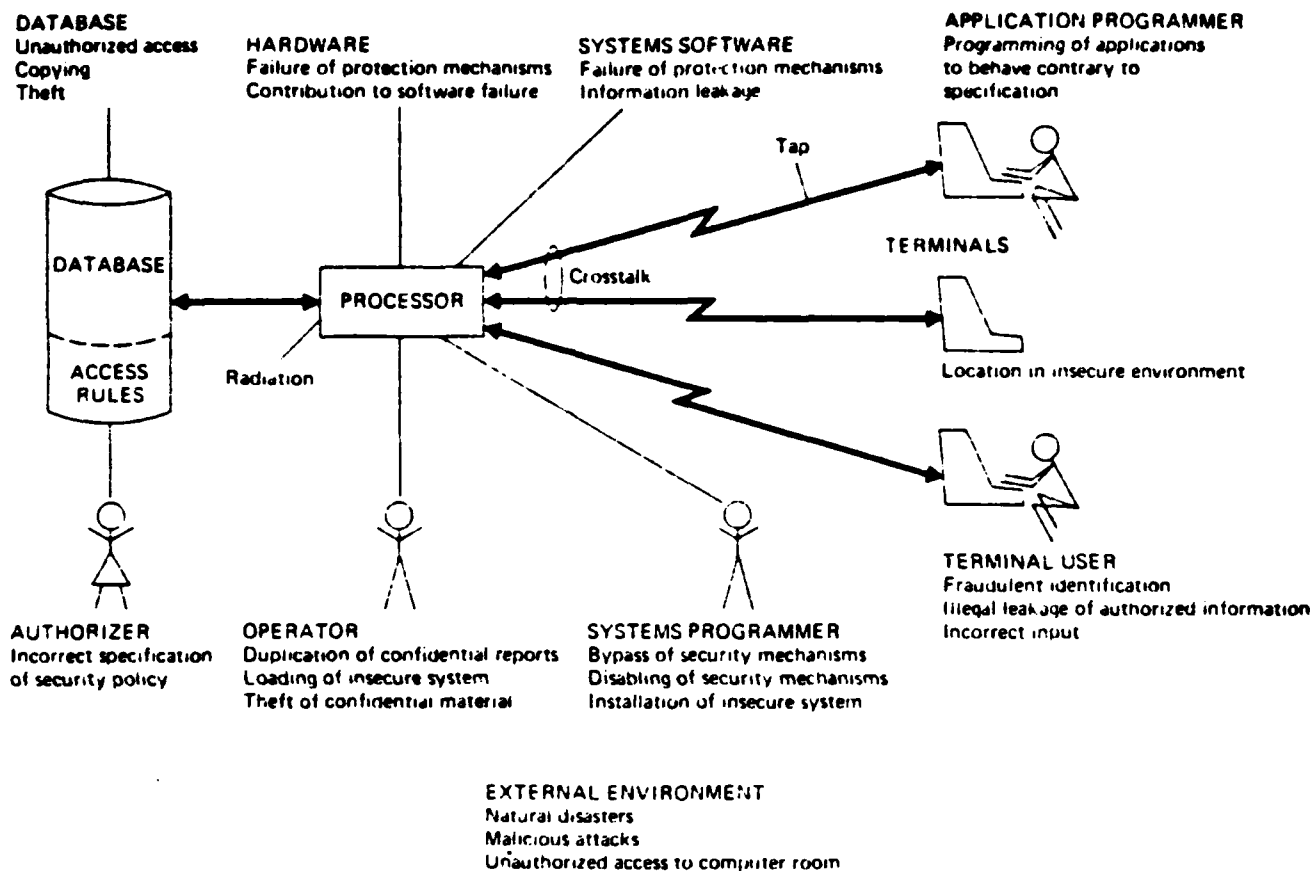

From:  
Database Security & Integrity  
By E.B. Fernandez

**Figure 3.2 Security Threats.**

In Figure 3.2 , we see the possibility of a malicious conduct by exploiting loopholes in the system. There are also threats resulting from human errors, such as accidentally destroying information, or allowing it to be seen by unauthorized people. In addition, natural disasters may destroy or prevent access to information. These threats are classified as nonmalicious threats.

#### D. SECURITY PROCEDURES AND MECHANISMS

Security threats arise from a wide variety of sources, therefore procedures and mechanisms necessary to provide a secure environment must cover many areas of the enterprise.

External procedures must be set up so that security mechanisms implemented within the system can be effective. We must select personnel who have access to highly classified information through security clearance procedures.

Storage devices and other hardware must be physically protected against any damage from natural disasters or malicious attack. Protection of removable storage against theft is also necessary. We also need backup systems for copying data files at different locations to protect against information loss.

Information may be stolen or tapped during transmissions, and encryption is one way to protect this data.

In summary, the security of a database depends on a complex set of protective measures: human, software, and hardware [Ref. 14].

#### E. SECURITY POLICIES

An access-control<sup>3</sup> system determines the way a subject<sup>4</sup> may access<sup>5</sup> data or objects.<sup>6</sup>

-----  
<sup>3</sup>Access-control. A strategy for protecting objects from unauthorized access.

<sup>4</sup>Subject. An active user of a computer system together with any other entity acting on behalf of a user or on behalf of the system; for example, processes, jobs, and procedures may be considered subjects. Certain subjects may also be considered to be objects of the system.

<sup>5</sup>Access. The ability and the means necessary to store or retrieve data, to communicate with, or otherwise make use of any resource in a computer system.

<sup>6</sup>Object. In a formal security model, an identifiable resource, data container or related entity of the system; the counterpart of subject. Software-created entities such

There are many kinds of access-control policies and they depend upon the categories of information and the positions of the users (subjects).

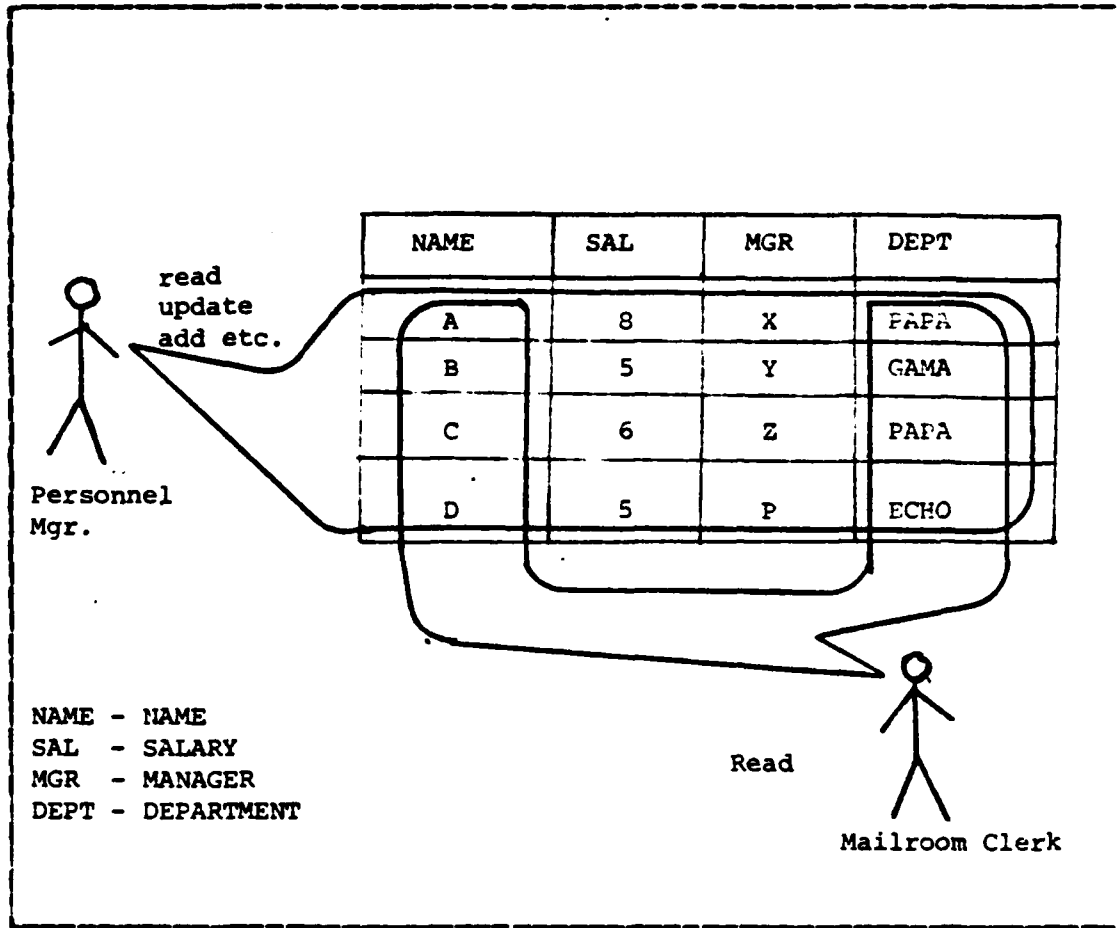

Figure 3.3 Access-type-dependent Access Control.

Figure 3.3, shows a situation where not everybody can see the whole file. Users are given access to the file, according to their position.

-----  
as files, programs and directories are objects, as well as hardware resources such as memory blocks, disk tracks, terminals, and tapes.

An access can be of several forms:

- r - read
- w - write
- a - append
- d - delete, and
- e - execute

An execute access is often used but omitted from this model due to the fact that execute access in the proposed protection architecture is similar to a read access.

To be qualified to access specific data, a user must conform to the military security conventions of classification, category, and need-to-know.

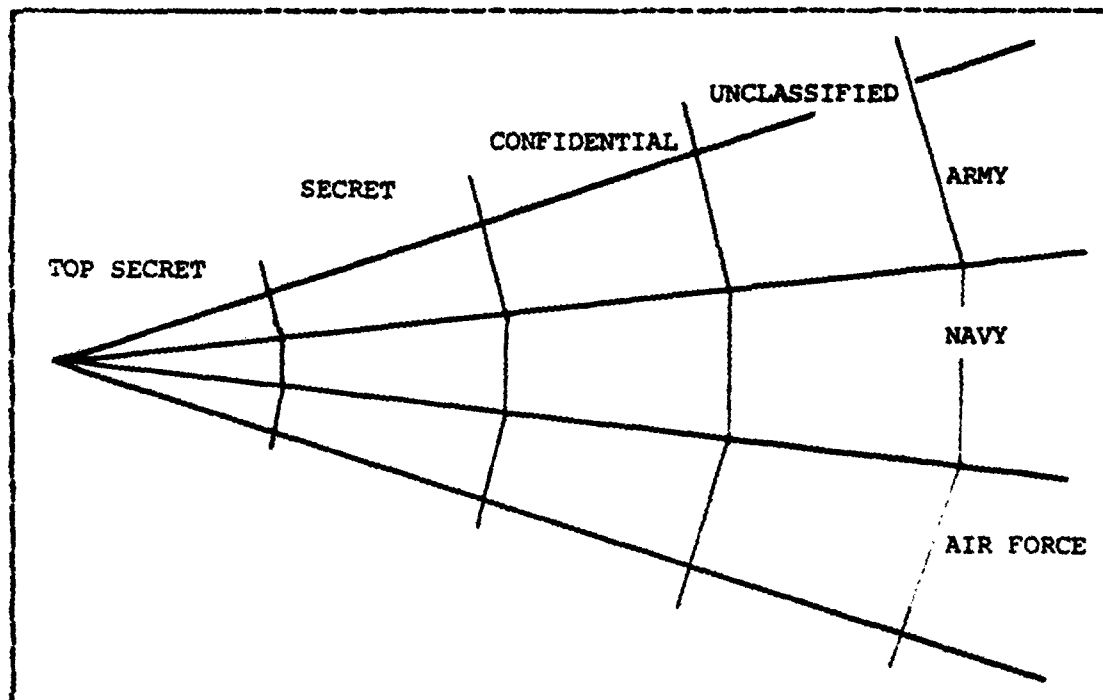

Figure 3.4 Combination of Compartment and Levels.

In military, for example, the Army, Navy and Air Force have different kinds of categories of files ranging from top secret to unclassified files. Thus by a combination of

compartmentalization and levels, a good policy for control information flow can be created.

#### P. MULTILEVEL MODEL

This model introduces the concept of levels and categories. Each subject is assigned a clearance level, and each object is assigned a classification level. Every person in the military has different security levels that permit how far (s)he may access the file and how much (s)he can see the file. Therefore a security level is a composite of: { A, B }, where A is the classification level and B is the set of categories.

One security level is said to dominate another if and only if:

1. its classification or clearance level > the other, and
2. its category set contains the other.

Clearance and classification levels are ordered as follows:

top secret > secret  
secret > confidential  
confidential > unclassified

Security levels are only partially ordered however, so that some subjects and objects are not comparable. In Figure 3.5, L2 is dominated by L1, since its level of classification and its set of categories is higher. On the other hand security levels of L1 and L3, are not comparable. The elements of the above model are summarized in Figure 3.6

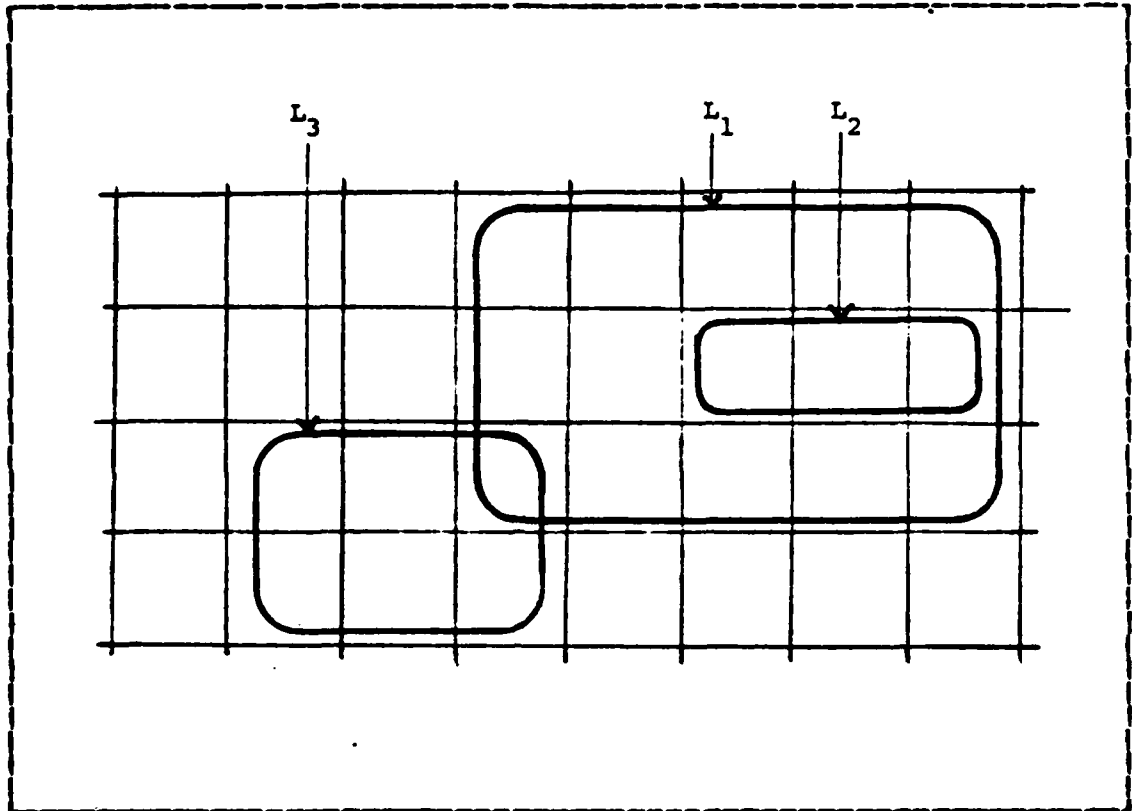

Figure 3.5 Ordering of Security Level.

Access to an object can be through either observing (READ) the object or altering (APPEND) the object, and from this combination we can determine the access type:

- \* not both
- \* READ
- \* APPEND
- \* WRITE

The multilevel model considers the states of a secure system, which are described by:

1. the current access set, which is a set of triples ( subject, object, access type ) or (s,o,t),
2. an access matrix,

Element	Interpretation
Subject s	Process
Object o	Data, files, ...
Classifications	Clearance level of subject, classification level of object
Categories	Access privileges
Security level	(Classification, category set)
Access attribute t	No observe, no alter; observe only; observe and alter; alter only
Access matrix	Discretionary security
Request	Changes current access or other aspects of system state
(s, o, t)	Current access
Decision	Yes, no, error, or ?
Rules	Determine decision, next state

From:  
Database Security &  
Integrity  
E.B. Fernandez

Figure 3.6 Elements of the Multilevel Model.

3. the security level of each subject, and
4. the maximum and current security levels of each subject.

1. Requirements to Read Data from a Data Set

A user may read a set of data if, and only if his clearance dominates the classification of a data set. The clearance of user (U) dominates a set of data (D) if, and only if,

military classification (U) > military classification (D)  
category (U)  $\subseteq$  category (D)  
U need-to-know ( read D)

## 2. Requirement to Write Data into a Data Set

A user may not write data into a set of data if the classification of the data he is writing dominates the classification of the data into which he is writing. That is, if the user wishes to write data (d) into data set (D), it is required that

military classification (d) < military classification (D)

category (d)  $\geq$  category (D)

U need-to-know (write D)

## IV. THE MULTICS CONCEPTS

### A. GENERAL CONCEPT

The Multiplexed Information and Computing System [Ref. 1] (MULTICS), employs the concept of rings of protection, based on:

1. Need to know, and
2. Firewall, to minimize damage due to errors.

Basically protection of data or objects in Multics is achieved by compartmentalizing all of the stored information into discrete packages called segments, where each is associated with a set of access attributes.

This chapter will discuss the concepts of access control, protection, and filing concepts in Multics, since these filing concepts will be a basis for the implementation of the existing personnel database in the following chapter.

### B. ACCESS CONTROL AND PROTECTION

In Multics, compartmentalization [Ref. 11] is achieved through two primary mechanisms:

1. Per-Segment Access Control
2. Concentric Rings of Protection

These mechanisms complement one another.

#### 1. Per-segment Access Control

Per-Segment Access Control is a means of denoting and controlling the type of access to a particular shared segment given to an individual user. A segment may be

shared by two or more processes. The subject who creates the segment and grants permission to share to a user, may specify the type of access to be given to each grantee. By this privilege, Multics guarantees that a user can safeguard the information he creates and files away for future use. Multics permits the coexistence of many processes, each of which competes for the system's physical resources and employs the same file system hierarchy.

The hierarchical directory structure in Multics which controls the file system looks like ordinary file. It includes authors, users listing and access type permitted to each user which is granted individually. Each author listed in the directory is associated with a file in the access control list ( ACL ).

## 2. Concentric Rings of Protection

The ring mechanism, by contrast, offers intraprocess protection of a segment. The concentric-rings concept is essentially a generalization of S (supervisor) and U (user) domains. The segments of any process are associated with a set of generally two or possibly more concentric rings.

A ring procedure prevents any user from referring to inner ring data segments which have higher level classification. A user is permitted to access more privileged procedures only through specially controlled entry points called "gates".

By subsetting the segments of a process into rings and by effectively controlling interactions and communication between segments of different rings (supervisory or userlike), Multics has the potential to isolate trouble and limit the damage in the system. When an outside ring is damaged, this will not effect the inner ring, but damage to the inner ring will cause damage to the outside ring as well.

Ring brackets are associated with accessible segments as shown in Figure 4.1 .

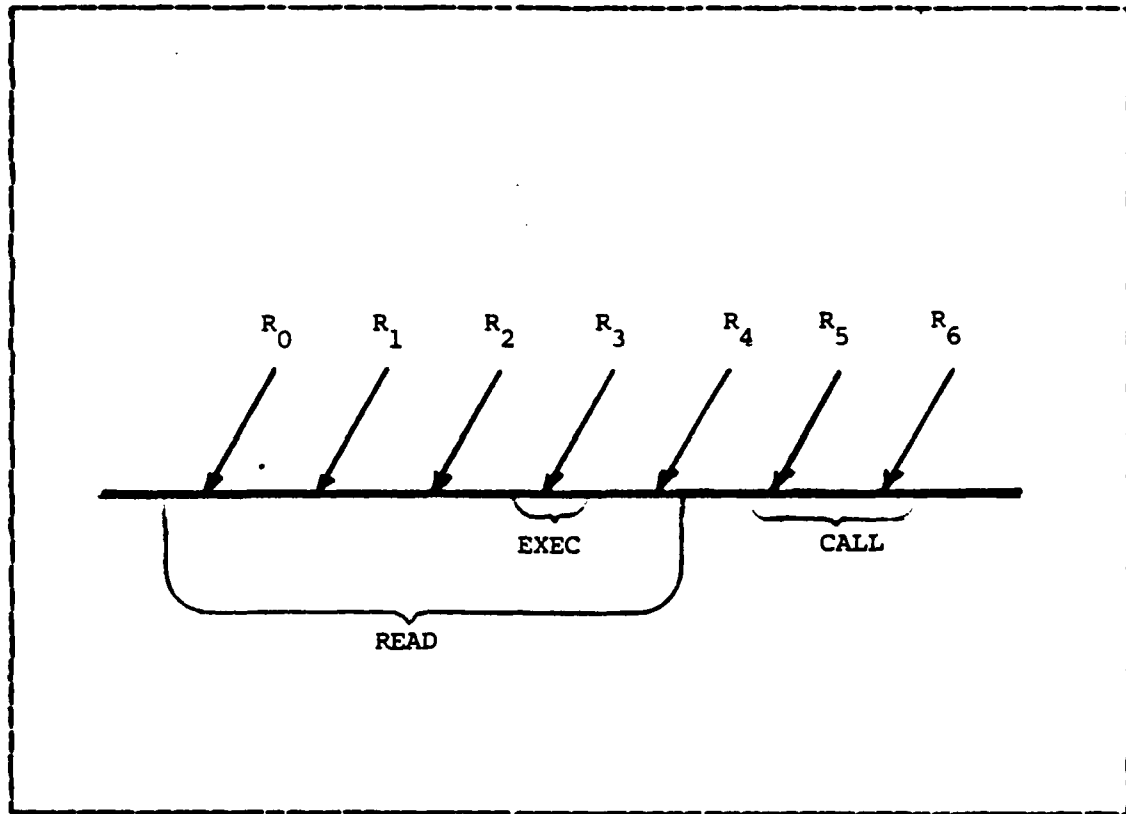

Figure 4.1 Segment Privileges.

Read and Write privileges are always associated with a ring-bracket starting at ring 0. In Figure 4.1 for example, the read bracket is defined as ring 0 to ring 4, which means that if a process is currently being executed in ring 0,1,2,3 or 4, then it may read the segment.

The Call bracket is defined as ring 5 and 6, which means that only when a process is executing in ring 5 or 6 can it call this segment when the segment is being executed, as the process is in ring 3.

In Multics , all storage are organized as named segments, and the segment is the unit of protection. A segment can contain either data or procedures.

A Multics process is usually associated with an end user who is identified by a unique number. In the database context an end user invokes a database application program by combining a number of procedures. Eventually one of these procedures will call a DBMS procedure, which in turn may call other DBMS or operating-system procedures. The user can build protected subsystems by grouping procedures into segments that can then be protected from one another.

Associated with each process is a descriptor segment, which is a vector of segment descriptor words (SDWs) providing addressability to all the segments accessible to the process. A directory system is used to locate a segment when it is first referenced by a process. The directory entry for a segment contains an access-control list specifying which users can access the segment and what their rights are. If the requested access is authorized, the segment is added to the user's virtual memory by adding the appropriate SDW to the user's descriptor segment.

Initially all information is stored in the access-control list. However, when the segment is first referenced, the information is copied into the SDW for the segment. For every subsequent access by the process the SDW alone is checked by hardware to determine whether an access is authorized.

### C. MULTICS FILE SYSTEM

The Multics filing system consists of two modules: Segment Control and Directory Control. Here, file and segment are entirely synonymous, since the concept of segment is merely an extension of the concept of file.

The segment Control Module (SCM) interprets the intent of the user's symbolic references to segments. It determines to which, if any, of the segments already known to the process a given symbolic name refers. If none, the Segment Control Module must then determine if a new segment is to be created and placed in the hierarchy.

When using the SCM, a Known Segment Table (KST) is needed to store segments currently part of the process. SCM maintains control over these reference-name-segment-number pairs in a given process. Its job is to develop and reuse each name-number pair in its proper context.

The directory Control Module (DCM) is used to search all inquiries about the status or location of segments and/or their descriptions, because only this module is permitted to read and alter the contents of the directory segments.

### 1. Directory Structure

This filing system has a directory structure that contains two types of entries which may be added to it:

1. branches and
2. links.

A branch is a detailed description of a segment located in the secondary storage of records that comprise the segment. A link is a special kind of named entry whose purpose is to point to another entry, normally in some (any) other directory. This allows a useful form of cross-referencing capability, to be superimposed over the basic tree structure formed by the branch-type entries. Figure 4.2 shows an example of the conceptual model of the file-system tree structure.



To reach a certain branch, a certain path is needed using path\_name and relative\_path\_name. A path\_name, is a list of the node names from the root to the branch (or link) inclusive, where elements of the list are separated by the ">" character. For example, to search for "sub" the following path name is used:

```
"> user_dir_dir > project1 > usera1_directory > sub",
```

and to search for "sort" the path name used is:

```
">user_dir_dir > project1 > usera1_directory > sort"
```

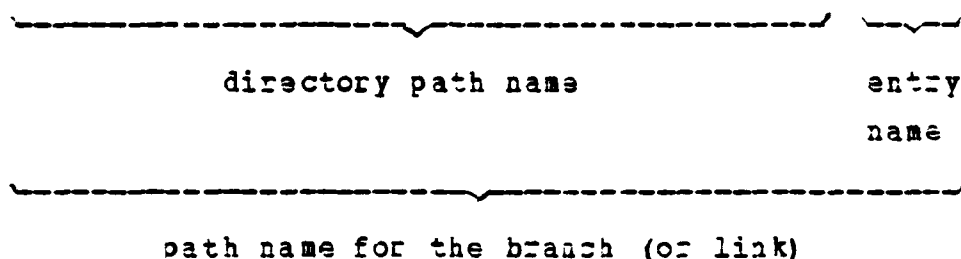

In other words, the Multics link is considered a shorthand for symbolic pathname, therefore, it introduces no additional structure.

Figure 4.3 shows that from directory A, the symbolic name "E" is shorthand for "> B > E ". Any path name may begin with "> ", if a path name begins with other than ">", the given path is referred to as a relative path name.

At all times, an executing process is associated with a working directory. This is a directory the process happens to be currently "using". It is merely a reference marker to a point in the hierarchy from which it becomes convenient to describe a relative path to other segments.

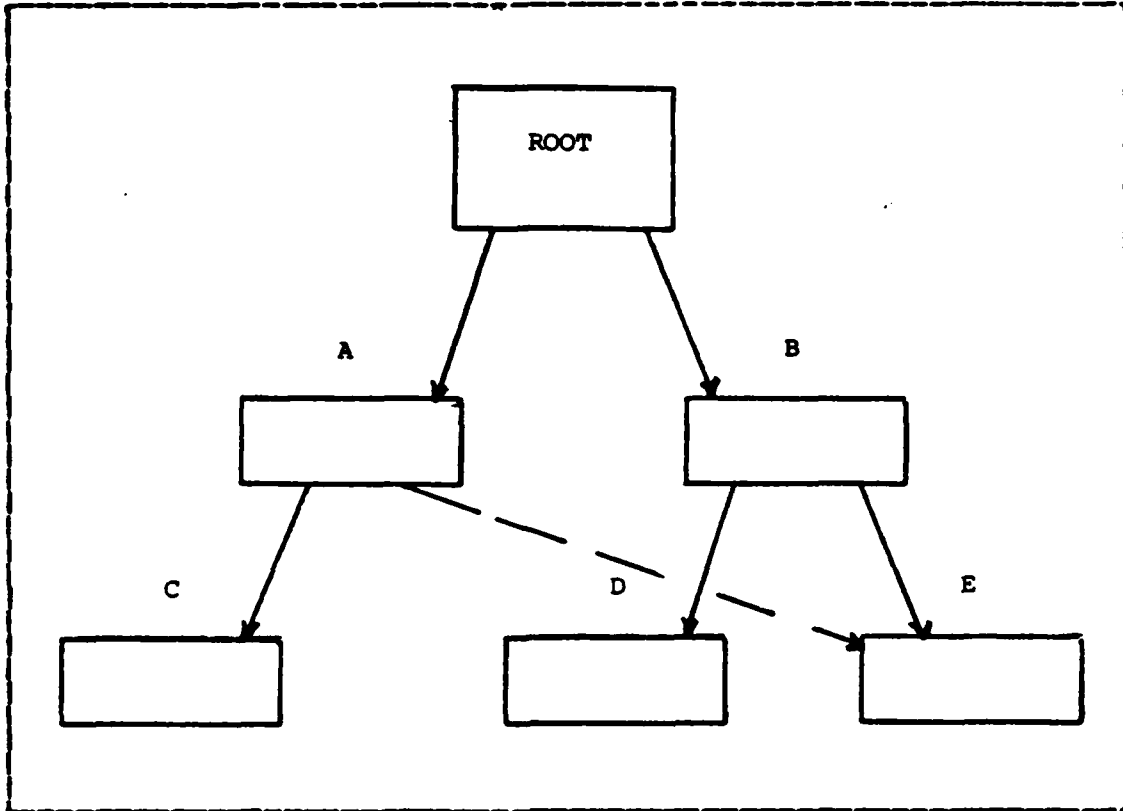

Figure 4.3 Interpretation of Links.

Thus, a tree path to a particular node may be described relative to the working directory of a process. For example referring to Figure 4.2 the path name for `sort` is simply "sort", and the path name for `delete` is "a1\_library > delete".

It is also possible to use the relative path-name convention when referring to a branch that is not a descendant of the working directory. This is done with the aid of the character "<". It is interpreted as parent of the working directory. And "<<" would mean parent of parent of the working directory, and so on. For example, relative path name for < `usera3_directory` > is "<< project2 > usera3\_directory" or "user\_dir\_dir > project2 > usera3\_directory"

## 2. Elements of a Secure Multics

Corresponding to a state (b,M,f,H) is a set of information structure in Multics [Ref. 2]. The following correspondences have been identified:

- b - Segment Descriptor Words (SDW)
- M - Access Control List (ACL)
- f - Information in directory segments and special process security tables
- H - Branches

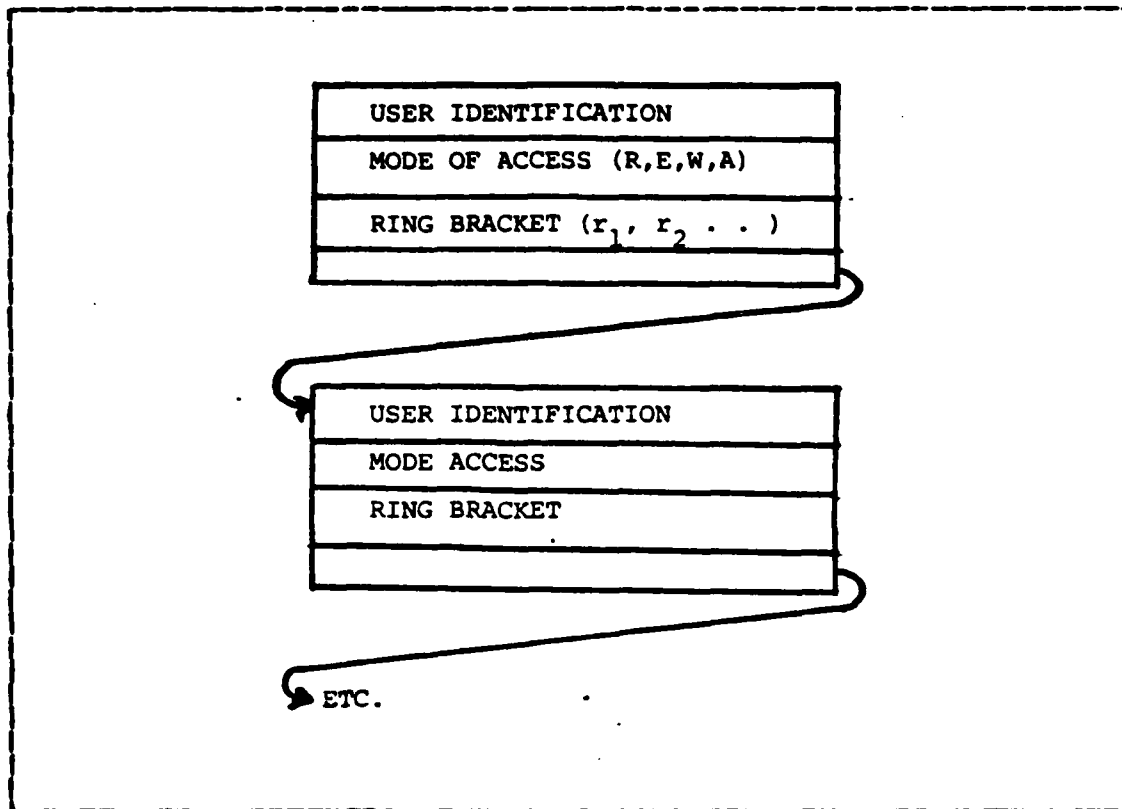

Figure 4.4 Data Structure of an ACL for an Individual Branch.

An element  $(S_i, O_j, x)$  in  $b$  indicates that subject  $S_i$  has current access to object  $O_j$  in access mode  $x$ .

In  $SDW$  is a field which indicates access permission (write, read, execute, or append)

An entry in  $M$  such as  $\{r, w\}$  indicates that subject  $S_i$  has read and write permission with respect to object  $O_j$ , if  $O_j$  is a data segment.

As example of the data structure of an access-control list for an individual branch is shown in Figure 4.4.

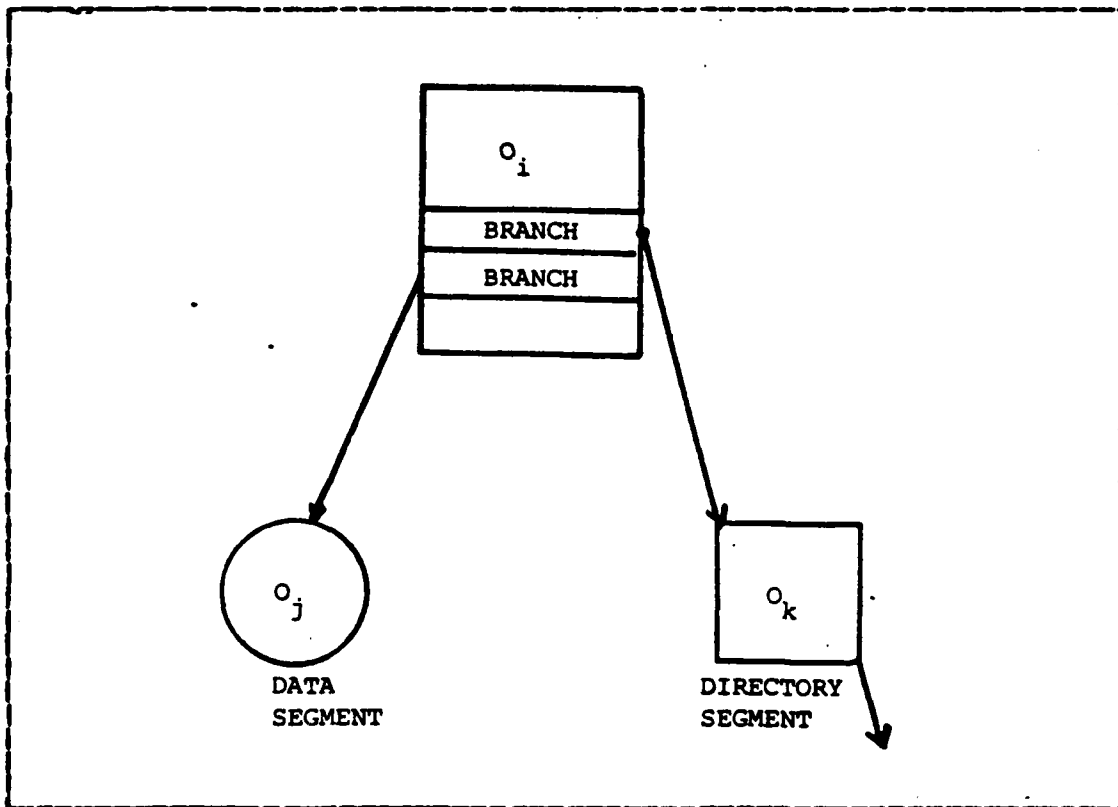

Figure 4.5 Multics Hierarchy Equivalent.

### 3. Retrieving File-branch Information

The hierarchy  $H$  of the model is structured to reflect the tree structure among segments realized by branches in Multics. If  $O_i$  and  $O_j$  are objects in the model and  $H(O_i)$  includes  $O_j$ , then  $O_i$  is the parent of  $O_j$ . Figure 4.5 shows this situation.

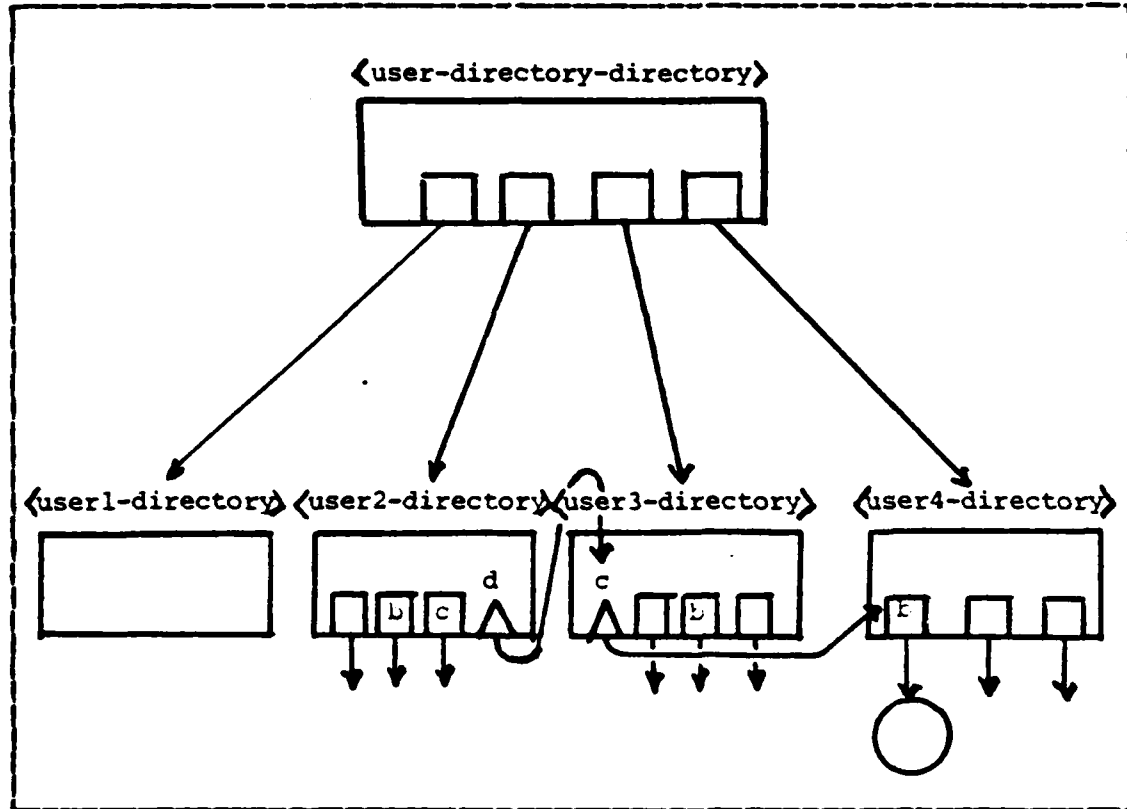

Figure 4.6 Chain of Links.

When directory control is supplied a path name for the purpose of retrieving corresponding file-branch information, the desired directory entry is retrieved by link or branch. If it is a branch, the target has been reached, and if it is a link the path name found in a link is then employed for a repetition of the retrieval process. It is possible that a chain of links eventually leads to a branch.

Figure 4.6 shows how user4 grants permission to user3, and user3 grants permission to user2 to use their routines. If user2 and user3 appear in the access control list for <b> in user4's user directory, then user2 may use "d" as a symbolic reference and user3 may use "c" as a symbolic reference to the segment whose branch entry is named "b".

## V. IMPLEMENTATION OF MULTICS IN DATABASE SECURITY

The basic security model including data security in Multics has been discussed in the previous chapter. Before we further discuss the implementation of database security we will take some assumptions as followed: Firstly, although the Multics system was developed and applied to operating systems for Honeywell computers, we will assume that it can also be used by other computers in general.

Secondly, we assume that users in the Indonesian Navy database system are limited to five assistants for Chief of Staff of the Indonesian Navy, namely:

1. Assistant for Security
2. Assistant for Operations
3. Assistant for Personnel
4. Assistant for Logistics
5. Assistant for Planning

The second assumption is needed because there are some offices supervised by the Assistants which currently deal with the personnel database system.

The description of a directory has been discussed in Chapter IV, therefore we will not discuss how to find a segment in this chapter.

The personnel database in the Indonesian Navy is divided into 17 segments. The method proposed here adds 2 segments which are:

Segment 400, which is followed by elements number 401-403, is divided into two, namely segment 400 which is followed by elements number 401 and segment 500 which is followed by elements number 501. This change is needed since element's owners are different.

For the same reason, segment 500 which is followed by elements 501-502, is divided into two segments, namely segment 600 followed by elements number 601-607 and segment 700 followed by elements number 701-705.

All changes are shown in the table in Appendix C.

We can summarize to this point that the personnel database is now divided into 19 segments and there are 5 users, which follow the sequence of assistant staffs. It has been determined who owns each segment, and each owner has the authority to update the contents of his segment(s).

To implement the new security method mentioned above, it is necessary to set up a table containing all segments and their relation to each user. The table tells what segment belongs to whom and what kind of accesses are authorized to other users. In this case the DBA (Database Administrator) can arrange the table in the proper order.

TABLE I  
Access Table

```

=====
ELM  DATA-NAMETYPE OF ACCESS
#           S1      S2      S3      S4      S5
=====
100  MAINID      R      R      RWAD   R      R
-----
200  CHARACT    R      -      RWAD   -      -
-----
300  MARR       -      -      RWAD   -      -
-----

```

400	ADDR	R	-	RWAD	-	-
500	ADDRSTA	-	-	R	RWAD	-
600	BODYCHAR	-	-	RWAD	-	-
700	PERSIZ	-	-	R	RWAD	-
800	CATEG	R	R	RWAD	R	R
900	RANK	R	R	RWAD	R	R
1000	PROFESS	R	R	RWAD	-	R
1100	EDUC	R	R	RWAD	-	R
1200	SUBJ	R	R	RWAD	-	R
1300	PAM	R	-	RWAD	-	-
1400	FACT	R	-	RWAD	-	-
1500	FEDUC	-	-	RWAD	-	-
1600	PAYROLL	-	-	-	RWAD	-
1700	SEC	RWAD	-	-	-	-

1800 WHOINV RWAD - - - -

-----  
1900 MEAS RWAD - - - -  
=====

R - read  
W - write  
A - append  
D - delete

Security is divided into 4 levels :

1. Top secret
2. Secret
3. Confidential, and
4. Unclassified

Segment numbers 1700, 1800, and 1900 are in the classified levels and the other segments classifications will be determined in the future, depending on the needs of the Navy.

## VI. CONCLUSIONS AND RECOMMENDATIONS

It is justified here to draw some conclusions and make recommendations concerning the importance of personnel database security in the Indonesian Navy.

The conclusions can be described as follows:

1. Database security is very important to any database system, especially in the military.
2. The Multics system provides basic concepts to achieve a sound database security system.
3. The Indonesian Navy personnel database security can be improved by applying such concepts as the one described in this thesis.

In order to implement this security model in the Indonesian Navy database personnel system, it is recommended to:

1. Assign security personnel under the DBA who will be responsible for the security of the existing database.
2. Conduct further research to explore possible enhancements to the physical design related in this proposal.

**APPENDIX A**  
**DATABASE PERSONNEL TABLES**

Each of these tables contains two elements: code and description. Example: " 1Male " indicates code number 1 is Male.

1. PERSONAL STATUS:

A. Military

01 Volunteer	03 Titular
02 Obligated	

B. Civilian

11 Daily_laborer	
12 Monthly_laborer	
13 Monthly_laborer organic	
14 Temporary Government_official	
15 Pre_Government_official	
16 Civilian_Government_official	
17 Civilian_Military_Titular Government_official	

2. PERSONAL CATEGORY:

0 Not clear	5 Waiting for placement
1 Active organic	6 Waiting for direction
2 In charge	7 Pre_retired
3 In assistance	8 Money waiting (UT)
4 In direction	9 Retired

3. SEX:

1 Male	2 Female
--------	----------

4. MARITAL STATUS

1 Married	2 Not married
-----------	---------------

5. CHILDREN ALLOWANCE STATUS:

1 Claimed by him/ herself	2 Claimed by spouse
------------------------------	---------------------

6. HOUSING STATUS:

1 Government-quarters	4 Private/owned
2 Mess	5 Rented
3 Ship	6 Contract/leased
7 With relations	

7. BLOOD TYPE:

1 A	4 O
2 B	5 X
3 AB	

8. COLOR OF SKIN:

1 White	4 Yellow-brown
2 Yellow	5 Brown
3 Black	

9. HAIR:

1 Straight-lank	3 Straight-stiff
2 Curly	4 Wavy

10. COLOR OF EYES:

1 Black	3 Brown
2 Blue	4 Green

11. SIZE OF PANTS/SHIRT:

1 Small	3 Large
2 Medium	

12. RELIGION:

1 Moslem	4 Hindu
----------	---------

2 Catholic  
3 Protestant

5 Budhist  
6 Cofucian

13. STATUS OF RANK:

1 Effective  
2 Temporary  
3 In education

4 Military obligated  
5 Military titular

14. TYPE OF PROMOTION:

1 Regular  
2 Extraordinary

3 Honor (meritorious)  
4 Honour-grace (posthumous)

15. STATUS OF PLACEMENT:

0 Organic  
1 Labor (non organic)  
2 In charge (detached  
from parent command)

3 In assistance (temporary  
additional duty)  
4 In direction (independent  
duty)

16. RESULT OF EDUCATION:

1 Graduated  
2 Not graduated

3 Incomplete

17. FAMILY RELATION:

0 Spouse  
1 Child number 1  
2 Child number 2  
3 Child number 3  
4 Child number 4

5 Child number 5  
6 Child number 6  
7 Child number 7  
8 Child number 8  
9 Child number 9

18. RANK:

A. Military:  
99 Third Sailor  
98 Second Sailor  
97 First Sailor  
95 Second Corporal

95 First Corporal  
 88 Second Sergeant  
 87 First Sergeant  
 86 Head Sergeant  
 85 Sergeant Major  
 84 Second Assistant Lieutenant  
 83 First Assistant Lieutenant  
 82 Candidate Officer  
 78 Second Lieutenant  
 77 First Lieutenant  
 76 Captain  
 68 Major  
 67 Lieutenant Colonel  
 66 Colonel  
 58 First Admiral (Commodore)/Brigadier General  
 57 Rear Admiral/Major General  
 55 Vice Admiral/Lieutenant General  
 55 Admiral/General

B Civilian

48 Group	I/A	27 Group	III/B
47 Group	I/B	26 Group	III/C
46 Group	I/C	25 Group	III/D
45 Group	I/D	18 Group	IV/A
38 Group	II/A	17 Group	IV/B
37 Group	II/B	16 Group	IV/C
36 Group	II/C	15 Group	IV/D
35 Group	II/D	14 Group	IV/E
28 Group	III/A		

19. CORPS:

A. Military

100 Sailor/Deck (for officer only)  
 151 Deck

162 Torpedo  
163 Weapon  
164 Constable  
165 Signal  
166 Telegram  
157 Under-Water Weaponry  
  
200 Technician/Engineer (for officer only)  
251 Mechanist  
252 Construction  
253 Ship Construction  
264 Airplane Maintenance  
  
300 Electronics (for officer only)  
351 Radio  
362 Radio-Radar Mechanic  
363 Electro-Machine Mechanic  
354 Electrician  
365 Sub-Weapon Electrician  
366 Electro Mechanic  
367 Weapon Electro Mechanic  
368 Electronica  
  
400 Marine (for officer only)  
461 Infantry  
462 Amphibious  
463 Field Artillery  
464 Air Defence Artillery  
465 Tank  
466 Pansam (Amphibious Tank)  
467 Transportation  
468 Zipur (Defense Construction)  
469 Communication-Electronica  
470 Nurse  
471 Field Support  
  
500 Administration (for officer only)

561 Writer/Typist  
562 Finance  
563 Support  
564 Family bussiness  
565 Cook-1  
566 Cook  
567 Tailor  
  
600 Health (for officer only)  
661 Nurse  
662 Radiologist  
663 Analyst  
664 Dental Technician  
665 Chemist  
666 Assistant Chemist  
  
700 Specialist (for officer only)  
761 Judicature  
762 Intelligence  
763 Transportation  
764 Carpenter  
765 Physical Fitness  
766 Musician  
767 Photography  
768 Cinematography  
769 Miscellaneous  
  
800 Woman (for officer only)  
861 Communication  
862 Writer/Typist  
863 Finance  
864 Information  
865 Physical Fitness  
866 Nurse  
867 Nav-Information Defence  
868 Air Traffic Controller

900 Clergy (for officer only)

B. Civilian:

- 000 Administration
- 001 General Administration
- 002 Finance Administration
- 003 Labor Administration
- 004 Support Administration
- 005 Nursing Administration
- 006 Technical Administration
- 007 Typist
- 008 Stencil Mechanic
- 009 Nursing Staff
- 010 Statistic Administration
- 011 Law Administration
- 012 Library Administration
- 013 Transportation Administration
- 014 Housing Administration
- 015 Post Administration
- 016 Miscellaneous Administration
  
- 017 Technician
- 018 Ship Technician
- 019 Engine/Machine Technician
- 020 Electro Technician
- 021 Construction Technician
- 022 Carpenter
- 023 Welding Technician
- 024 Telephone-telegraph Technician
- 025 Radio Technician
- 026 Mechanic/Driver
- 027 Laborer
- 028 Photographer
- 029 Film Operator

030 Metal Technician  
031 Painter  
032 Weapon Technician  
033 Fire Safety Inspector  
034 Constructor  
035 General Controller  
036 Shipyard Worker  
037 Pump Technician  
038 Railroad Technicians  
039 Meteorological Technician  
040 Miscellaneous  
  
041 Nurse  
042 Dental Nurse  
043 General Nursing  
044 Midwife  
045 Pharmacy  
046 Physiotherapy  
047 Radiology  
048 Pediatric Nurse  
049 General Medical  
050 Ophthalmologist  
051 Throat-nose-ear Physician  
052 Neurologist  
053 Dermatologist  
054 Dietitian  
055 Miscellaneous  
  
056 Specialist  
057 Teacher/Instructor  
058 Messenger  
059 Cook  
060 Gardener  
061 Shoemaker  
062 Tailor  
063 Barber

064 Janitor  
065 Forester  
066 Sketcher  
067 Security  
068 Lifeguard  
069 Parking Master  
070 Fire Brigade  
071 Physical Fitness  
072 Artist  
073 Clergy  
074 Laundry  
075 Ocean Tide  
076 Petro-chemical Technician  
077 Geography  
078 Miscellaneous

20. GROUP CODE OF EDUCATION:

000 General Development  
001 National Defense  
002 Joint Command & Staff College  
003 Command & Staff College Level  
004 2nd Officer Continuing Education Level  
005 1st Officer Continuing Education Level  
011 NCO Continuing Education Level  
  
100 Formation  
101 Military Academy Level  
102 Fundamental Officer Education Level  
103 Candidate Officer Education Level  
111 Candidate NCO Education Level  
112 Candidate Corporal Education Level  
113 Candidate Enlisted Education Level  
  
200 Labor  
201 Labor Education Level

- 300 General Education
- 301 University Level
- 302 Academy Level
- 303 Senior High School Level
- 304 Junior High School Level
- 305 Elementary School Level (graduate)
- 306 Elementary school level (not graduate)
  
- 400 Specialist Military Education
- 401 Specialist
- 402 Officer Specialist
- 403 NCO Specialist
- 404 Enlisted Specialist
- 405 Civilian Specialist
  
- 500 General Course

21. ECHELON OF PROFESSION:

- |                |                |
|----------------|----------------|
| 11 Echelon 1-A | 23 Echelon 2-C |
| 12 Echelon 1-B | 24 Echelon 2-D |
| 13 Echelon 1-C | 25 Echelon 2-E |
| 14 Echelon 1-D | 26 Echelon 2-F |
| 15 Echelon 1-E | 31 Echelon 3-A |
| 16 Echelon 1-F | 32 Echelon 3-B |
| 17 Echelon 1-G | 33 Echelon 3-C |
| 18 Echelon 1-H | 34 Echelon 3-D |
| 21 Echelon 2-A | 35 Echelon 3-E |
| 22 Echelon 2-B | 40 Functional  |

22. STATION:

Not include here for security reasons.

23. VIOLATION:

- |              |                 |
|--------------|-----------------|
| 1 Discipline | 3 Negative data |
| 2 Law        |                 |

24. WHAT:

This table will be completed later by an Intelligence/Security officer, since the author does not have data at this time.

**APPENDIX B**  
**DATABASE DICTIONARY**

This data dictionary contains descriptions of the Personnel Data Base segments (data elements groups) and their data elements. There are six columns in the table:

1. Element Number (ELM #). The data element/segment number contains four digits. The first two digits is the segment number, beginning from the root and increasing by one (leading zeroes suppressed), and another two digits for the data element number in the segment beginning from one and increasing by one.
2. Data Element (DATA\_ELEMENT). This column contains data element/segment name as it is known to the users.
3. Data Name (DATA\_NAME). This column contains the unique name for data element/segment which is to be used by programmer/user when retrieving data from the Database.
4. Type (TYPE). This column contains the data element's type where N means Numeric and AN means Alpha-Numeric.
5. Number of Character (OF CHAR). This column contains number of characters in the record field of the data element/segment.
6. Description (DESCRIPTION). This column contains the description of the data element/segment. Described are the data element/segment relationships (dependent, root, etc.), key record/segment, administrative

control, usage, and identifications. This description helps the programmer/ user to find the path to desire data elements/segments in the database.

The abbreviations used in the data dictionary table are: DB for Database, segm for segmen, lev for level, tbl for table. YYMMDD for Year (two digits), Month (two digits) and Date (two digits), occur for occurrence, dependt for dependent, Kg for Kilogram, and Cm for Centimeter.

```

=====
ELM      DATA-ELEMENT      DATA-   TY-   #OF   DESCRIPTION
#                NAME      PE   CHAR
=====
100  Main identification  MAINID           76  Root segm DB
                                lev 1, segm 1,
                                one occur

101  Personal Serial      SERNUM    N     9  Record key
      Number              (Main Key)

102  Name                  NAME      AN    26  Name, title

103  Corps                  CORPS     N     3  See corps tbl
                                (19)

104  Sex                    SEX       N     1  See sex tbl (3)

105  Birth date             DMBIRTH   N     6  YYMMDD

106  Birth place            PNBIRTH   AN    15  Town (city)

107  Religion               RELIGION  N     1  See religion
                                tbl (12)

108  Tribe                  TRIBE     AN    15  -

-----
200  Personal              CHARACT           Dependt segm of
                                root, lev 1,
                                segm 2, one
                                occur

```

300	Marriage	MARR		7	Dependnt segm of CHARACT, lev 3, segm 3, repeated
301	Marital status	MARST	N	1	See marital status tbl (4) segm key
302	Date of status	MARDT	N	6	YYMMDD

400	Address	ADDR		33	Dependnt segm of CHARACT, lev 3, segm 4, repeated
401	Address	ADDRESS	AN	26	-
402	Housing status	HOUSE	N	1	See housing status tbl (6) segm key
403	Date of status	HOUSDT	N	6	YYMMDD

500	Body characteristic	BODYCHAR		18	Dependnt segm of CHARACT, lev 3, segm 5, one occur
501	Weight	WEIGHT	N	3	In Kg
502	Height	HEIGHT	N	3	In Cm
503	Blood type	BLOOD	N	1	See blood type tbl (7), segm key
504	Color of skin	SKIN	N	1	See color of skin tbl (8)
505	Hair	HAIR	N	1	See hair tbl (9)
506	Color of eyes	EYES	N	1	See color of

					eyes tbl (10)
507	Size of shoes	SHOES	N	2	-
508	Size of hat	HAT	N	2	-
509	Size of pants	PANTS	N	1	See pant shirt tbl (11)
510	Size of shirt	SHIRT	N	1	See pant shirt tbl (11)
511	Size of chest	CHEST	N	2	-
-----					
600	Category and status	CATEG		29	Dependt segm of CHARACT, lev 3, segm 6, one occur
601	Original personal status	ORPERST	N	2	See personal status tbl (1)
602	Date of original personal status	ORPERDT	N	6	YMMDD
603	Current personal status	CRPERST	N	2	See personal status tbl (1) segm key
604	Date of current personal status	CRPERDT	N	6	YMMDD
605	Personal category	CATEGORY	N	1	See personal category tbl (2)
606	Date of personal category	DTGORY	N	6	YMMDD
607	Active duty obligated time (Active service duty began)	DTACT	N	6	YMMDD
-----					
700	Rank	RANK		39	Dependt segm of

					root, lev 2, segm 3, repeated
701	Rank/Group	RANKG	N	2	See rank tbl (18), segm key
702	Status of rank	STRANK	N	1	See status of rank tbl (13)
703	Date of rank	DTRANK	N	6	YMMDD
704	Number of decision letter	NBDECLT	AN	8	Format: NNNNMMYY NNNN : Number MM : Month YY : Year
705	Date of decisicn letter	DTDECLT	N	6	YMMDD
706	Who gave the decision letter	GVDECLT	AN	15	Official functionary
707	Type of promotion	TPPROM	N	1	See type of promotion tbl (14)

---

800	Profession	PROFESS		71	Dependt segm of root, lev 2, segm 4, repeated
801	Name of profession	NMPROP	AN	15	-
802	Number of decision	NBDECP	AN	8	Format: NNNNMMYY NNNN : Number MM : Month YY : Year
803	Date of decision letter	DTPROP	N	6	NNNNNN-YMMDD
804	Number of professional warrant	NEWARP	AN	8	Format: NNNNMMYY NNNN : Number MM : Month YY : Year

805	Date of warrant	DTWARP	N	6	NNNNNN-YYMMDD
806	Echelon of profession	ECHELON	N	2	See echelon tbl (21)
807	Station	STATION	N	3	See station tbl (22)
808	Reporting date	DTSTAT	N	6	YYMMDD
809	Status of placement	STPLACE	N	1	See status of placement tbl (15)
810	Date of placement	DTPLACE	N	6	YYMMDD
-----					
900	Education	EDUC		73	Dependt segm of root, lev 2, segm 9, repeated
901	Group code of education	EDUCCD	N	3	See group code of education tbl (20), segm key
902	Education Institute's Name	EDUCNM	AN	15	-
903	Start date	EDUCSD	N	6	YYMMDD
904	Completion date	EDUCCM	N	6	YYMMDD
905	Station	EDSTAT	N	3	See ststion tbl (22)
906	Town (city)	EDTOWN	AN	15	-
907	Result of education	RESULT	N	1	See result of education tbl (16)
908	Class standing	CSTAND	N	3	-
909	Class size	CSIZE	N	3	-
-----					
1000	Subject	SUBJ		18	Dependt segm of EDUC, lev 3,

					segm 10, repeated
1001	Subject name	SUBJECT	AN	15	Segm key
1002	Grade	GRADE	AN	3	Can be numeric or alphabetic
-----					
1100	Family	FAM		76	Dependt segm of root, lev 2, segm 6, repeated
1101	Family name	FNAME	AN	26	Name, title
1102	Family relation	FREL	N	1	See family relation tbl (17), segm key
1103	Sex	FSEX	N	1	See sex tbl (3)
1104	Birth date	FDBIRTH	N	6	YYMMDD
1104	Birth place	FPBIRTH	AN	15	Town (city)
1105	Religion	FPRELIGI-	N	1	See religion tbl (12)
1107	Address	FADDR	AN	26	-
-----					
1200	Activity	FACT		48	Dependt segm of FAM, lev 3, repeated
1201	Name of activity	FNACT	AN	26	Segm key
1202	Place of activity	FPACT	AN	15	Town (city)
1203	Start date	FSACT	N	6	YYMMDD
1204	Completion date	FCACT	N	6	YYMMDD
-----					
1300	Family education	FEDUC		16	Dependt segm of FAM, lev 3, segm 13, repeated

1301	Education Institute's Name	FEDNACT	AN	15	-
1302	Group code of education	FCDACT	N	3	See group code of education tbl (20), segm key
1303	Result of education	FEDRES	N	1	See result of education tbl (16)
-----					
1400	Payroll	PAYROLL		59	Dependt segm of root, lev 2, segm 14, one occurr
1401	Date of begining payroll	DBPAY	N	6	YYMMDD
1402	Rank in payroll	RKPAY	N	2	See rank tbl (18)
1403	Payroll period	PERPAY	N	3	In Month
1404	Number of children authorized family allowance	CHFAM	N	1	-
1405	Status of children authorized family allowance	STCHFAM	N	1	See children allowance status tbl (5)
1406	Main salary	MAINSAL	N	6	In Rupiah
1407	Wife's family allowance	WPALL	N	5	In Rupiah
1408	Children family allowance	CHALL	N	5	In Rupiah
1409	Other family allowance	OTALL	N	5	In Rupiah
1410	Obligated reduction	OBRED	N	5	In Rupiah

1411	Rice reduction	RCRED	N	5	In Rupiah
1412	Other reduction	OTRED	N	5	In Rupiah
1413	Total salary	TOTSAL	N	6	In Rupiah
1414	Unit of payroll	UNPAY	N	4	See station tbl (22), segm key

---

1500	Security	SEC		35	Dependt segm of root, lev 2, segm 15, repeated
1501	Violation/Infringe	VTYPE	N	1	See violation/ infringe type tbl (23), segm key
1502	What	WHAT	N	3	See what tbl (24)
1503	Where	WHERE	AN	15	Town (city)
1504	When	WHEN	N	6	YYMMDD
1505	Why	WHY	N	5	This reason description is stored in other file with key number here (N 5)
1506	How	HOW	N	5	Same as 1505

---

1600	Who involved	WHOINV		50	Dependt segm of SEC, lev 3, segm 16, repeated
1601	Name involved	INVNAME	AN	26	Segm key
1602	Personal	PERSID	AN	9	Personal serial

	identification				number or other valid identi- fication
1603	Profession	PROFINV	AN	15	-
-----					
1700	Measures	MEAS		27	Dependt. segm of SEC, lev 3, segm 16, repeated
1701	Type of action	NMEAS	AN	15	Segm key
1702	Start date	SMEAS	N	6	YYMMDD
1703	Completion date	CMEAS	N	6	YYMMDD

=====

**APPENDIX C**  
**NEW DATABASE DICTIONARY**

This data dictionary contains descriptions of the Personnel Data Base segments (data elements groups) and their data elements. There are six columns in the table: (See Appendix B for abbreviations)

ELM #	DATA-ELEMENT	DATA-NAME	TY-PE	#OF CHAR	DESCRIPTION
100	Main identification	MAINID		76	Root segm DB lev 1, segm 1, one occur
101	Personal Serial Number	SERNUM	N	9	Record key (Main Key)
102	Name	NAME	AN	26	Name, title
103	Corps	CORPS	N	3	See corps tbl (19)
104	Sex	SEX	N	1	See sex tbl (3)
105	Birth date	DMBIRTH	N	6	YYMMDD
106	Birth place	PMBIRTH	AN	15	Town (city)
107	Religion	RELIGION	N	1	See religion tbl (12)
108	Tribe	TRIBE	AN	15	-
200	Personal	CHARACT			Dependt segm of root, lev 1, segm 2, one

occur

---

300	Marriage	MARR		7	Dependt segm of CHARACT, lev 3, segm 3, repeated
301	Marital status	MARST	N	1	See marital status tbl (4) segm key
302	Date of status	MARDT	N	6	YYMMDD

---

400	Address	ADDR		26	Dependt segm of CHARACT, lev 3, segm 4, repeated
401	Address	ADDRESS	AN	26	-

---

500	Address status	ADDRSTA		7	Dependt segm of ADDR, lev 4, segm 5, repeated
501	Housing status	HOUSE	N	1	See housing status tbl (6) segm key
502	Date of status	HOUSDT	N	6	YYMMDD

---

600	Body characteristic	BODYCHAR		10	Dependt segm of CHARACT, lev 3, segm 6, one occur
601	Weight	WEIGHT	N	3	In Kg
602	Height	HEIGHT	N	3	In Cm
603	Blood type	BLOOD	N	1	See blood type tbl (7), segm

					key
604	Color of skin	SKIN	N	1	See color of skin tbl (8)
605	Hair	HAIR	N	1	See hair tbl (9)
606	Color of eyes	EYES	N	1	See color of eyes tbl (10)
<hr/>					
700	Personal size	PERSIZ		8	Dependt segm of BODYCHAR, level 4, segm 7, one occur
701	Size of shoes	SHOES	N	2	-
702	Size of hat	HAT	N	2	-
703	Size of pants	PANTS	N	1	See pant shirt tbl (11)
704	Size of shirt	SHIRT	N	1	See pant shirt tbl (11)
705	Size of chest	CHEST	N	2	-
<hr/>					
800	Category and status	CATEG		29	Dependt segm of CHARACT, lev 3, segm 8, one occur
801	Original personal status	ORPERST	N	2	See personal status tbl (1)
802	Date of original personal status	ORPERDT	N	6	YYMMDD
803	Current personal status	CRPERST	N	2	See personal status tbl (1) segm key
804	Date of current personal status	CRPERDT	N	6	YYMMDD

805	Personal category	CATEGORY	N	1	See personal category tbl (2)
806	Date of personal category	DTGORY	N	6	YYMMDD
807	Active duty obligated time (Active service duty began)	DTACT	N	6	YYMMDD
-----					
900	Rank	RANK		39	Dependt segm of root, lev 2, segm 9, repeated
901	Rank/Group	RANKG	N	2	See rank tbl (18), esgm key
902	Status of rank	STRANK	N	1	See status of rank tbl (13)
903	Date of rank	DTRANK	N	6	YYMMDD
904	Number of decision letter	NBDECLT	AN	8	Format: NNNNMMYY NNNN : Number MM : Month YY : Year
905	Date of decision letter	DTDECLT	N	6	YYMMDD
906	Who gave the decision letter	GVDECLT	AN	15	Official functionary
907	Type of promotion	TPPROM	N	1	See type of promotion tbl (14)
-----					
1000	Profession	PROFESS		71	Dependt segm of root, lev 2, segm 10,

					repeated
1001	Name of profession	NMPROF	AN	15	-
1002	Number of decision	NBDECP	AN	8	Format: NNNNMMYY NNNN : Number MM : Month YY : Year
1003	Date of decision letter	DTPROF	N	6	NNNNNN-YYMMDD
1004	Number of professional warrant	NBWARP	AN	8	Format: NNNNMMYY NNNN : Number MM : Month YY : Year
1005	Date of warrant	DTWARP	N	6	NNNNNN-YYMMDD
1006	Echelon of profession	ECHELON	N	2	See echelon tbl (21)
1007	Station	STATION	N	3	See station tbl (22)
1008	Reporting date	DTSTAT	N	6	YYMMDD
1009	Status of placement	STPLACE	N	1	See status of placement tbl (15)
1010	Date of placement	DTPLACE	N	6	YYMMDD
-----					
1100	Education	EDUC		73	Depend+ segm of root, lev 2, segm 11, repeated
1101	Group code of education	EDUCCD	N	3	See group code of education tbl (20), segm key
1102	Education Institute's Name	EDUCNM	AN	15	-

1103	Start date	EDUCSD	N	6	YYMMDD
1104	Completion date	EDUCCM	N	6	YYMMDD
1105	Station	EDSTAT	N	3	See station tbl (22)
1106	Town (city)	EDTOWN	AN	15	-
1107	Result of education	RESULT	N	1	See result of education tbl (16)
1108	Class standing	CSTAND	N	3	-
1109	Class size	CSIZE	N	3	-
-----					
1200	Subject	SUBJ		18	Dependt segm of EDUC, lev 3, segm 12, repeated
1201	Subject name	SUBJECT	AN	15	Segm key
1202	Grade	GRADE	AN	3	Can be numeric or alphabetic
-----					
1300	Family	FAM		76	Dependt segm of root, lev 2, segm 13, repeated
1301	Family name	FNAME	AN	26	Name, title
1302	Family relation	FREL	N	1	See family relation tbl (17), segm key
1303	Sex	FSEX	N	1	See sex tbl (3)
1304	Birth date	FDBIRTH	N	6	YYMMDD
1304	Birth place	FPBIRTH	AN	15	Town (city)
1305	Religion	FPRELIGI	N	1	See religion tbl (12)
1307	Address	FADDR	AN	26	-

-----

1400	Activity	FACT		48	Dependnt segm of FAM, lev 3, segm 14 repeated
1401	Name of activity	FNACT	AN	26	Segm key
1402	Place of activity	FPACT	AN	15	Town (city)
1403	Start date	FSACT	N	6	YYMMDD
1404	Completion date	FCACT	N	6	YYMMDD

-----

1500	Family education	FEDUC		16	Dependnt segm of FAM, lev 3, segm 15, repeated
1501	Education Institute's Name	FEDNACT	AN	15	-
1502	Group code of education	FCDACT	N	3	See group code of education tbl (20), segm key
1503	Result of education	FEDRES	N	1	See result of education tbl (16)

-----

1600	Payroll	PAYROLL		59	Dependnt segm of root, lev 2, segm 16, one occurr
1601	Date of begining payroll	DBPAY	N	6	YYMMDD
1602	Rank in payroll	RKPAY	N	2	See rank tbl

(18)

1603	Payroll period	PERPAY	N	3	In Month
1604	Number of children authorized family allowance	CHFAM	N	1	-
1605	Status of children authorized family allowance	STCHFAM	N	1	See children allowance status tbl (5)
1606	Main salary	MAINSAL	N	6	In Rupiah
1607	Wife's family allowance	WFALL	N	5	In Rupiah
1608	Children family allowance	CHALL	N	5	In Rupiah
1609	Other family allowance	OTALL	N	5	In Rupiah
1610	Obligated reduction	OBRED	N	5	In Rupiah
1611	Rice reduction	RCRED	N	5	In Rupiah
1612	Other reduction	OTRED	N	5	In Rupiah
1613	Total salary	TOTSAL	N	6	In Rupiah
1614	Unit of payroll	UNPAY	N	4	See station tbl (22), segm key

---

1700	Security	SEC		35	Dependt segm of root, lev 2, segm 17, repeated
1701	Violation/Infringe	VTYPE	N	1	See violation/ infringe type tbl (23), segm key
1702	What	WHAT	N	3	See what tbl (24)
1703	Where	WHERE	AN	15	Town (city)

1704	When	WHEN	N	6	YYMMDD
1705	Why	WHY	N	5	This reason description is stored in other file with key number here (N 5)
1706	How	HOW	N	5	Same as 1505
-----					
1800	Who involved	WHOINV		50	Dependt segm of SEC, lev 3, segm 18, repeated
1801	Name involved	INVNAME	AN	26	Segm key
1802	Personal identification	PERSID	AN	9	Personal serial number or other valid identi- fication
1803	Profession	PROFINV	AN	15	-
-----					
1900	Measures	MEAS		27	Dependt segm of SEC, lev 3, segm 19, repeated
1901	Type of action	NMEAS	AN	15	Segm key
1902	Start date	SMEAS	N	6	YYMMDD
1903	Completion date	CMEAS	N	6	YYMMDD
=====					

## LIST OF REFERENCES

1. Adleman N. Effects of Producing a Multics Security Kernel. Virginia: Honeywell Information Systems, Inc., 1975.
2. Bell D. E., and La Padula L. J. Secure Computer System: Unified Exposition and Multics Interpretation. Virginia: Honeywell Information Systems, Inc., 1976.
3. Date C. J. An Introduction to Database System. Philippines: Addison-Wesley Publisher Co., Inc., 1981.
4. Downs D. and Popeck G. J. A Kernel Design for a Secure Database Management System. IEEE, pp. 507-514, October 1977.
5. Fernandez E. B, Summers R. J, and Wood C. Database Security and Integrity. Philippines: Addison-Wesley Publishing Co., Inc., 1981.
6. Hinke T. H., and Schaefer M. Secure Data Management System. California: System Development Corp., Santa Monica, 19765
7. Inmon W. H. Effective Database Design. New Jersey: Prentice-Hall, Inc., 1975.
8. Kroenke, David. Database Processing, fundamentals, modeling, applications. Chicago: Science Research Associates, Inc., 1977.
9. Madnicks S. E, Donovan J. J. Operating Systems. New York: McGraw-Hill, Inc., 1977.
10. Moedjiono, The Preliminary Personnel Database Design for the Indonesian Navy. U.S. Thesis Naval Postgraduate School, Monterey, 1982.
11. Organick E. I. The Multics System. Massachusetts: The M.I.T. Press, 1972.
12. Price W. R., Ericksen D. P., Multics Security Integration Requirements. Virginia: Honeywell Information Systems, Inc., 1976.

13. Price W. R. and Eriksen D. P. Multics Security Kernel Top Level Specification. Virginia: Honeywell Information Systems, Inc., 1975.
14. Wormington F. D., and Giesler C. E., Secura DBMS. New York: Rome Air Force Development Center, Air Force System Command, Griffis Air Force Base, 1982.

INITIAL DISTRIBUTION LIST

	No. Copies
1. Defense Technical Information Center Cameron Station Alexandria, Virginia 22314	2
2. Library, Code 0142 Naval Postgraduate School Monterey, California 93943	2
3. Department Chairman, Code 54 Department of Administrative Science Monterey, California 93943	1
4. Professor Norman R. Lyons, Code 54 Lb Department of Administrative Science Naval Postgraduate School Monterey, California 93943	1
5. Professor Daniel R Dolk, Code 54 dk Department of Administrative Science Naval Postgraduate School Monterey, California 93943	1
6. LCDR Mulyo Wibisono DISPAHAL, MABES TNIAL. Jl. Gunung Sahari 56 Jakarta Pusat - Indonesia	1
7. CDR Amrun Sehan JANMINPERSAL, MABES TNIAL. Jl. Gunung Sahari 56 Jakarta Pusat - Indonesia	1
8. LCDR Moedjiono DISPULAHTAL. Jl. Gatot Subroto 101. Jakarta Pusat - Indonesia	1
9. Perpustakaan Pusdikital SESKO ABRI BAG. LAUT. Cipulir, Kebayoran Lama Jakarta Selatan - Indonesia	2

FILM  
4-8