

AD-A139 155

LABORATORY TESTS OF A SCALE-MODEL POWER MANAGEMENT
VALVE(U) FORGE AEROSPACE INC WASHINGTON D C
C W MESSINGER SEP 76 DAAG53-76-C-0042

1/1

UNCLASSIFIED

F/G 13/11

NL

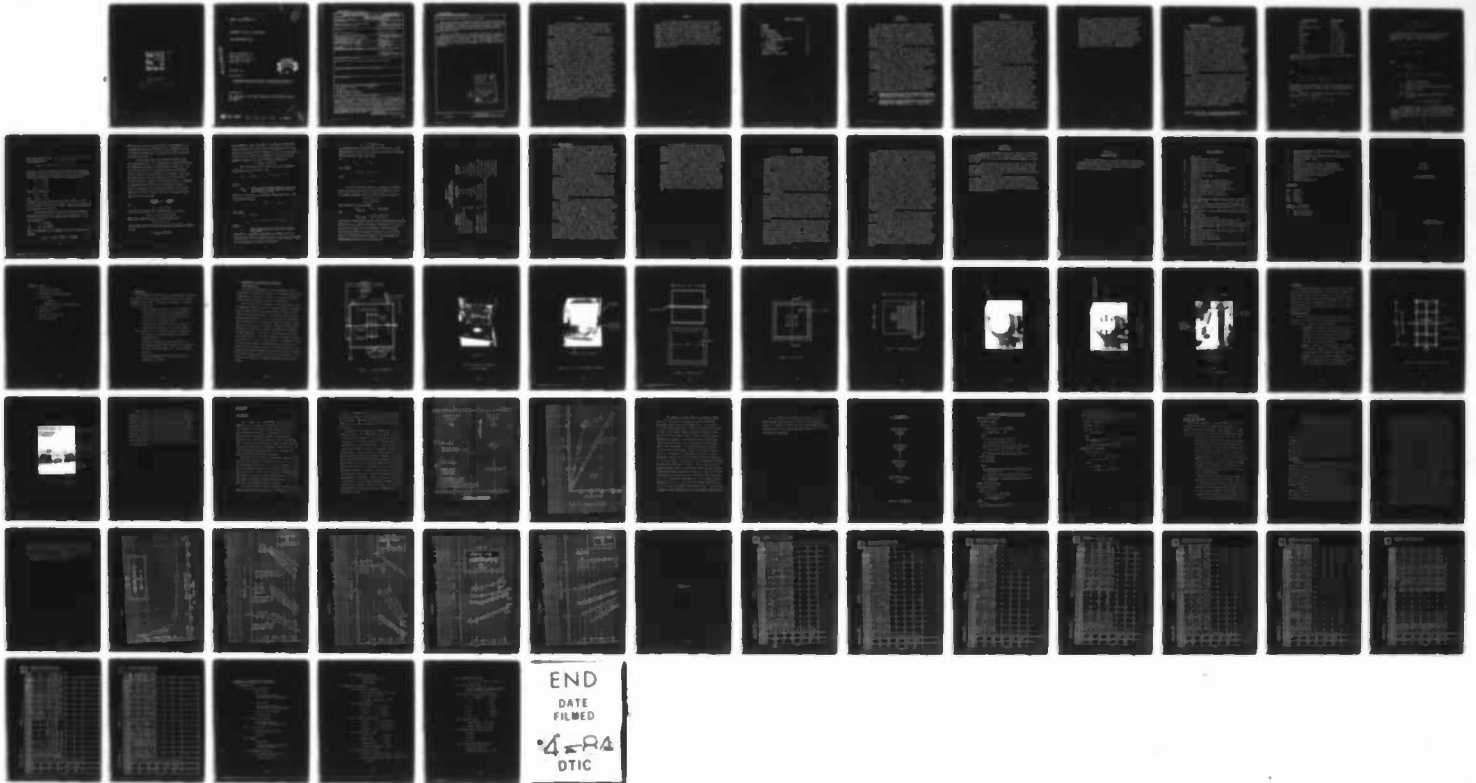

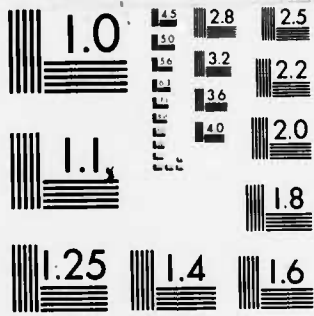

MICROCOPY RESOLUTION TEST CHART
NATIONAL BUREAU OF STANDARDS-1963-A

2 copy

(1)

^{-76-C-}
REPORT DAAG53-~~6~~-76-0042-001

LABORATORY TESTS OF A SCALE-MODEL

POWER MANAGEMENT VALVE

CARL W. MESSINGER, JR.
FORGE AEROSPACE, INC.
1705 DESALES STREET, N.W.
WASHINGTON, DC 20036

DTIC
ELECTE
MAR 21 1984
S D
B

SEPTEMBER 1976

FINAL REPORT

APPROVED FOR PUBLIC RELEASE; DISTRIBUTION UNLIMITED

PREPARED FOR

U.S. ARMY MOBILITY EQUIPMENT RESEARCH AND DEVELOPMENT COMMAND
FORT BELVOIR
VA 22060

AD A139155

copy # 1

cut
2/22/77
K.W.

DTIC FILE COPY

84 03 20 106

DC 87970

UNCLASSIFIED

SECURITY CLASSIFICATION OF THIS PAGE (When Date Entered)

REPORT DOCUMENTATION PAGE		READ INSTRUCTIONS BEFORE COMPLETING FORM
1. REPORT NUMBER DAAG53-76-C-0042-001	2. GOVT ACCESSION NO. AD-A2	3. RECIPIENT'S CATALOG NUMBER 39255
4. TITLE (and Subtitle) Laboratory Tests of a Scale-Model Power Management Valve	5. TYPE OF REPORT & PERIOD COVERED FINAL October 75-July 76	
	6. PERFORMING ORG. REPORT NUMBER	
7. AUTHOR(s) Carl W. Messinger, Jr.	8. CONTRACT OR GRANT NUMBER(s) DAAG53-76-C-0042	
9. PERFORMING ORGANIZATION NAME AND ADDRESS Forge Aerospace Inc. 141820 1705 DeSales Street, N.W. Washington, D. C. 20036	10. PROGRAM ELEMENT, PROJECT, TASK AREA & WORK UNIT NUMBERS Prog. Elem. 6.27.08A Proj. No. TF762607AH67-1A	
11. CONTROLLING OFFICE NAME AND ADDRESS U.S. Army Mobility Equipment R & D Command Fort Belvoir, VA. 22060	12. REPORT DATE September 1976	
	13. NUMBER OF PAGES 70	
14. MONITORING AGENCY NAME & ADDRESS (if different from Controlling Office)	15. SECURITY CLASS. (of this report) Unclassified	
	15a. DECLASSIFICATION/DOWNGRADING SCHEDULE	
16. DISTRIBUTION STATEMENT (of this Report) Approved for public release; distribution unlimited		
17. DISTRIBUTION STATEMENT (of the abstract entered in Block 20, if different from Report)		
18. SUPPLEMENTARY NOTES		
19. KEY WORDS (Continue on reverse side if necessary and identify by block number) Air Cushion Vehicle Valves Airflow Ground Effect Machines Surface Effects Vehicles <i>previously</i>		
20. ABSTRACT (Continue on reverse side if necessary and identify by block number) → Dimensions and design characteristics of a one-quarter scale model of the PMV as proposed for installation in the MERADCOM Air Cushion Boat (ACB) were developed. A test device was built with provision for variation of the spring constant and damping coefficient in order to validate the equation of motion developed under an earlier contract. However, because it was necessary to provide a variable feedback area, the equation of motion did not accurately		

DD FORM 1473 JAN 73 EDITION OF 1 NOV 68 IS OBSOLETE

UNCLASSIFIED

SECURITY CLASSIFICATION OF THIS PAGE (When Date Entered)

DC 37970

UNCLASSIFIED

SECURITY CLASSIFICATION OF THIS PAGE(When Data Entered)

represent the dynamic system actually tested.

Within the matrix of parameters tested the valve was found to operate satisfactorily with a rather wide range of values for the key parameters. Satisfactory operation means that the valve closes automatically within a short period following venting of the jupe and reopens without undue delay following the re-sealing of the jupe.

Owing to the absence of true dynamic similarity, not only of the test device but also of the air supply system, design characteristics of a full-scale system could not be established from the test of a single valve. It is recommended that a system of four jupes, each with a PMV, with a common air supply be tested prior to further development of the installation in the ACB.

Accession For	
NTIS GRA&I	<input checked="" type="checkbox"/>
DTIC TAB	<input type="checkbox"/>
Unannounced	<input type="checkbox"/>
Justification	
By _____	
Distribution/	
Availability Codes	
Dist	Avail and/or Special
A-1	



UNCLASSIFIED

SECURITY CLASSIFICATION OF THIS PAGE(When Data Entered)

SUMMARY

The Power Management Valve (PMV) has been examined previously for possible application to the Air Cushion Barge (ACB) developed by MERADCOM. Laboratory testing of a small-scale valve was recommended in order to validate the theory developed during the earlier investigation.

Using dimensional analysis, the design characteristics of a one-quarter scale model of the valve as proposed for the ACB were developed. Design values for the spring constant and damping coefficient were calculated, using the criterion of a natural frequency equal to zero. However, neither the analysis nor the original test proposal had considered the leakage, or feedback, flow area, as a variable. In order to include this as a parameter in the test device, it was necessary to provide complete sealing of the PMV, with a separate, adjustable feedback flow area. As a result, the equation of motion does not apply to the dynamic system that was built and tested.

Although there was no direct correlation between the results of model testing and the full-scale equation of motion, the testing demonstrated successful operation of the valve. It was concluded that the valve will function, as proposed, as a passive, automatic shut-off device. It also was concluded that the design values for spring constant and damping coefficient appropriate for a full-scale installation could not be established by the test of a single valve. Further, demonstration of the adequacy of the dynamic behavior of the valve cannot be demonstrated independent of the barge. It is recommended that a large-scale model of four jupes with individual PMV's and a common air supply be tested prior to the development of PMV installation for the ACB.

PREFACE

The laboratory testing described herein was performed under Contract DAAG53-76-C-0042, sponsored by the U.S. Army Mobility Equipment Research and Development Command. The test program was conducted under DA Project Sea to Inland Logistics System, Air Cushion Barge, Program Element 6.27.08A, Project Number IF762607AH67-LA. The work was performed under the technical cognizance of Mr. John E. Sargent, Marine and Bridge Division. The concept definition of the PMV for the ACB, performed under Contract DAAJO2-74-C-0057, is described in Report DAAJO2-74-C-0057-001.

TABLE OF CONTENTS

SUMMARY	1
PREFACE	2
I INTRODUCTION	4
II THE PROBLEM	5
III INVESTIGATION	7
3.1 Dimensional Analysis	7
3.2 Test Program	15
IV DISCUSSION	17
V CONCLUSIONS	19
VI RECOMMENDATIONS	20
LIST OF SYMBOLS	21
APPENDIX A - TEST REPORT	23

SECTION I
INTRODUCTION

This report describes a program of laboratory testing of a power management valve (PMV). The PMV was examined previously for possible application to an air cushion barge (ACB) being developed by the U. S. Army Mobility Equipment Research and Development Command (MERADCOM). The concept for the PMV is an outgrowth of the Automatic Air Valving Surface Effects Device (AAVSED) which has been investigated by Forge Aerospace Inc. for the U. S. Army and the National Aeronautics and Space Administration (NASA).

The present program was undertaken with the specific objective of validating by laboratory test the available theoretical analyses of the PMV. The analyses were performed under prior contracts and are reported in References 1 and 2. The testing of a scale-model of the PMV was considered a step in the development of the concept necessary before undertaking the design and demonstration of a full-scale installation in the MERADCOM ACB or other air cushion vehicle (ACV).

This report includes a review of the problem of loss of lift by an ACV following skirt venting and the potential of the PMV to alleviate this problem. The determination of the characteristics of a scale-model of the valve is described and the test specification and test plan also are presented. The results of the test program are reviewed and pertinent conclusions presented. The report also contains recommendations for the further development of the PMV concept.

- Ref. 1. Concept Definition of the Air Cushion Vehicle Power Management Valve Concept, Rept. DAAJ02-74-C-0057-001, Forge Aerospace, Inc. Washington, D. C. October 1974.
- Ref. 2. Investigation of a New Automatic Air Valving Surface Effects Device (AAVSED), NASA CR 114-737, Forge Aerospace, Inc., Washington, D. C., January 1974.

SECTION II THE PROBLEM

A problem shared by all air-cushion vehicles is the loss of lift following venting of a skirt. In certain circumstances, such as slow traverse over a void, it may not be possible to pressurize the cushion again and the vehicle will be unable to move under its own power. One approach to the alleviation of this problem has been the subdivision of the cushion into a number of individual cells. However, there is no assurance of success with this approach, regardless of the actual technique. Unless there is an independent air supply for each cell, the increase in mass flow through the cell whose skirt has been vented may be sufficient that other cells can no longer support their share of the weight and the vehicle will settle. This possibility clearly would be minimized were there a way to shut off the flow of air to the vented cell and to keep it closed off until the skirt has sealed and the cushion pressure can be maintained.

An experimental air-cushion barge (ACB) developed by MERADCOM has been fitted, in one configuration, as a multicell vehicle using Bertin-type jupes. In this configuration four jupes are pressurized by each of two blowers. Therefore, the problem of a large-scale loss of lift following the venting of only one jupe has been encountered.

A proposed solution to this problem is the power management valve (PMV). The concept of this valve is that it remains open as long as the pressure differential across the valve orifice is small and closes automatically when the pressure differential becomes large. During a prior research effort sponsored by MERDC the possible application of the valve to several configurations of the ACB were investigated and one installation was recommended for concept definition (Ref. 1). However, the PMV concept has as yet been demonstrated in the laboratory in only very small scale

(Ref. 2). The work reported in Ref. 1 includes a theoretical development of the operation of the valve which, if valid, can be used in the design of full-scale installations. It was recommended that a program be undertaken with the objective of demonstrating the valve/juice combination. As a first step, the theory presented in Ref. 1 should be validated by appropriate laboratory test. A full-scale system, designed in accordance with the proven theory then could be subjected to appropriate tests to demonstrate and further investigate the concept. The program reported herein is the first step in the recommended program.

SECTION III INVESTIGATION

3.1 Dimensional Analysis

In the prior investigation of the Power Management Valve (PMV) in association with a multicell ACV (Ref. 1), an approximate solution was developed for the time history of the valve motion. This transient solution appeared to be an acceptable approximation, inasmuch as the original analysis of the AAVSED valve concept (Ref. 2) upon which the transient analysis relied had correlated well with experiments. Nevertheless, it was recognized that the experimental steady-state results may not be representative of a dynamic environment. Therefore, it had been recommended that the dynamic analysis be validated further before the solution was used in the design of full-scale hardware. This report describes the dynamic experiments undertaken to provide this validation. A full-scale installation in the jupes of the Air Cushion Barge (ACB) also having been proposed in Ref. 1., it was appropriate that the preliminary experiments be conducted with a scale-model of the proposed installation.

The forces acting upon an ACV can be related directly to the physical characteristics of the working fluids and of the craft. These relationships are reviewed by Trillo (Ref. 3), together with the principles of dimensional analysis. From this presentation it is possible to develop the appropriate relationship between the model and full-scale values of each characteristic. These relationships are expressed in terms of a dimensionless scale-factor $S = L_{fs}/L_m$, where L is characteristic linear dimension and the subscripts refer to "full-scale" and "model," respectively. For purposes of design of a dynamically similar model of a PMV, the following relationships are pertinent:

Ref. 3. R.L. Trillo, Marine Hovercraft Technology, United States Naval Institute, Annapolis, MD, 1971.

<u>Characteristic</u>	<u>Relationship</u>
Density	Constant
Acceleration (linear)	Constant
Time	$t_m = S^{-0.5} t_{fs}$
Frequency	$\omega_m = S^{0.5} \omega_{fs}$
Length	$L_m = S^{-1.0} L_{fs}$
Pressure	$P_m = S^{-1.0} P_{fs}$
Area	$A_m = S^{-2.0} A_{fs}$
Force	$F_m = S^{-3.0} F_{fs}$
Weight	$W_m = S^{-3.0} W_{fs}$

From these, the relationships for spring constant and damping coefficient are derived as

$$\frac{K_m}{K_{fs}} = \left(\frac{F_m}{L_m} \right) \frac{L_{fs}}{L} = \frac{S^{-3.0}}{S} = S^{-2.0}$$

and

$$\frac{C_{fm}}{C_{f_{fs}}} = \left(\frac{F_m t_m}{L_m} \right) \left(\frac{L_{fs}}{F_{fs} t_{fs}} \right) = \frac{S^{-3.0} S^{-0.5}}{S} = S^{-2.5}$$

With these scale-relationships, it will be possible to define the characteristics of a model similar to the proposed full-scale valve.

From Ref. 1 the equation of motion of the valve, valid for $t > 0$, is given as

$$h''(t) + 2\lambda h'(t) + \omega_n^2 h(t) = \gamma$$

where

$$\lambda = C_d / 2M$$

$$\omega_o^2 = \left[K + \frac{(F_o - F_c)}{2} \right] / M$$

$$\gamma = F_o / M$$

In the expression for ω_o^2 , F_o , and F_c are the fluid forces acting upon the valve in the open and closed positions, respectively. From Ref. 2 these are described as

$$F_o = \alpha [\pi r_o^2 (\Delta P)]$$

$$F_c = \beta [\pi r_o^2 (\Delta P)]$$

where

$$\alpha = \frac{(R/r_o)^2 - 1}{2 \log(R/r_o)}$$

$$\beta = \frac{C_h^2}{4} \left(\frac{r_o}{h_c} \right)^2 \left[1 + 2 \log(R/r_o) \right]$$

R = radius of valve disk

r_o = radius of valve orifice

h_c = height of valve disk in open position above plane of orifice

ΔP = $P_u - P_a$

C_h = discharge coefficient for the orifice, of the form

$$C_h = \frac{Q}{\pi r_o^2 (2\Delta P/\rho)^{1/2}}$$

As suggested in Ref. 1 it is appropriate to specify values for the design parameters such that the apparent natural frequency ω_o approaches zero. As seen from the definition of ω_o^2 , the design value of the spring constant then will be given by

$$K_{des} = \frac{F_c - F_o}{h_c}$$

Upon substitution of the relationships for F_c and F_o , this can be expressed as

$$K_{des} = r_o \Delta P \left[\pi \alpha \frac{r_o}{h_c} \left(1 - \frac{\beta}{\alpha} \right) \right]$$

From Ref. 2 the relationships for F_c and F_o are considered realistic for $R/r_o = 2.0$ and $r_o/h_c = 1.33$. In the proposed full-scale installation (Figure 1) the dimensions are:

$$R = 18 \text{ in.}$$

$$r_o = 10 \text{ in.}$$

$$h_c = 8 \text{ in.}$$

with the result that

$$R/r_o = 1.8$$

$$\text{and } r_o/h_c = 1.25$$

Although different than the values used in Ref. 2, they do not differ sufficiently to render invalid the expressions for the forces on the valve.

Using these geometric relations from the proposed full-scale design the two dimensionless parameters α and β are evaluated as

$$\alpha = 1.90544$$

$$\text{and } \beta = 0.84984 C_h^2$$

and the expression for the design value of the spring constant becomes

$$K_{des} = r_o \Delta P (7.4826 - 3.3373 C_h^2)$$

The value $C_h = 0.72$ is given by Ref. 2 as appropriate for a sharp-edged orifice. However, with a rounded entry and a slightly divergent duct, the coefficient can be as much as twice this value.

In selecting values for the spring constant K_{des} for purposes of test, it is appropriate to provide not only for possible variations in the discharge coefficient, but also for variations in the pressure drop ΔP consistent with the range of gross weights of the vehicle. The total footprint area of the multijoupe ACB is given in Ref. 1 as 385 ft^2 and the range of gross weight given is a minimum of approximately 20,000 lb and a maximum of 28,000 lb. With the assumption that the plenum pressure will be the same as the cushion pressure ($P_u = P_L$) the pressure drop ΔP will be in the range

$$\frac{20,000}{385} \leq \Delta P \leq \frac{28,000}{385}$$

or

$$52 \leq \Delta P \leq 73 \text{ psf}$$

and for the proposed valve configuration ($r_o = 10 \text{ in.}$)

$$43.3 \leq r_o \Delta P \leq 60.67 \text{ lb/ft}$$

When this range of values is used together with

$$0.72 \leq C_h \leq 1.5$$

the maximum range of values for the spring constant is found to be

$$0 \leq K_{des} \leq 350 \text{ lb/ft}$$

For purposes of test this range is considered unreasonably large; one-half this range will provide adequately for variations of both the vehicle loading (ΔP) and the configuration of the orifice. Hence, for purposes of the test plan the range of values of the spring constant is given as

$$0 \leq K_{des} \leq 175 \text{ lb/ft}$$

The relationship for a design value of the damping coefficient is given by Ref. 1 as

$$\lambda_{des} = \frac{1}{2} \left(\frac{F_o}{2Mv_o} \right)^{1/2} \log \left[\frac{F_o / \pi (R^2 - r_o^2)}{P_{I_{des}}} \right]$$

where

$P_{I_{des}}$ = design value of impact pressure (force of valve against the seat upon closing, per unit valve seat area)

Using the characteristic dimensions specified earlier, this relationship becomes

$$\lambda_{des} = 0.6454 \left(\frac{r_o \Delta P}{M} \right)^{1/2} C_h \left[\log \left(\frac{P_{I_o}}{P_{I_{des}}} \right) \right]$$

and since

$$C_f = 2M\lambda$$

$$C_{f_{des}} = 1.2918 (M r_o \Delta P)^{1/2} C_h \left[\log \left(\frac{P_{I_o}}{P_{I_{des}}} \right) \right]$$

where

M = mass of moving parts (valve disk, spring, and damper)

Assuming the full-scale valve disk to be made of 0.25 in. aluminum plate and the combined weight of the spring and damper to be one-quarter the weight of the disk,

$$M = 1.0 \text{ slug} \approx 32 \text{ lb}$$

It is appropriate to specify that the design value of the impact pressure be 60% of the force on the valve in the open position per unit valve seat area,

or

$$P_{I_{des}} = 0.6 P_{I_o}$$

As a result

$$\log \left(\frac{P_{I_o}}{P_{I_{des}}} \right) = 0.511$$

and

$$C_{f_{des}} = 1.179 C_h (\Delta P)^{1/2} \quad \text{lb-sec/ft}$$

As with the spring constant, consideration must be given to variations in both the orifice coefficient and the vehicle loading. Using the same ranges of value, i.e.,

$$0.72 \leq C_h \leq 1.5$$

$$52 \leq \Delta P \leq 73,$$

and evaluating at the extremes,

$$C_{f_{des \text{ min}}} = 5.27 \quad \text{lb-sec/ft}$$

and

$$C_{f_{des \text{ max}}} = 15.08 \quad \text{lb-sec/ft}$$

Using these relationships and the scale relationships derived previously, the ranges of parameters appropriate for a one-quarter scale model can be calculated. Both full-scale and model parameters are shown in Table 3-1. The values shown for the model were presented in the test plan as a design specification for the test device.

TABLE 3-1

DESIGN PARAMETERS
Full-Scale and 1/4-Scale

<u>Parameter</u>	<u>Full-Scale</u>	<u>1/4-Scale</u>
Valve Disk radius R	18 in.	4.5 in.
Valve Orifice radius r_o	10 in.	2.5 in.
Valve Travel h_c	8 in.	2.0 in.
Valve Mass M_v	1.0 slug	0.0156 slug
	≈ 32 lb	≈ 0.5 lb
Cushion Pressure P_L	$52 \leq P_L \leq 73$ psf	$13 \leq P_L \leq 18.3$ psf
Spring Constant K	$0 \leq K \leq 175$ lb/ft	$0 \leq K \leq 11$ lb/ft
Damping Coefficient C_f	$5.27 \leq C_f \leq 15.08$ lb-sec/ft	$0.165 \leq C_f \leq 0.471$ lb-sec/ft
		$0.0138 \leq C_f \leq 0.0393$ lb-sec/in.

3.2 Test Program

The experimental set up and the test program are described in detail in Appendix A. Neither the analyses nor the original test plan had addressed adequately the importance of the "leakage" or feedback flow. For automatic operation of the valve, the shut-off by the valve must not be complete. It is this "leakage" flow that permits the pressurization of the cushion, or jupe, to start after the skirt has resealed. The valve then reopens when the total force due to the combination of the pressure on the underside of the valve and the spring exceeds the closing force on the plenum chamber side of the valve.

In the earlier analyses and experiments this flow literally had been leakage under the valve disk. In the initial small-scale experiments, the imperfections in the mating surfaces of the disk and the seat prevented total sealing and at least a small amount of air continued to flow when the valve was closed. Analytically, good agreement with experimental data was obtained when lubrication theory was used to define the pressure profile below the "closed" valve.

However, in neither the prior tests nor analyses was the valve opening cycle investigated, particularly to find a relationship between the leakage area and the opening time. Intuitively it was apparent that there will be such a relationship. Similarly, there will be a relationship between the area and the plenum pressure for a given value of valve opening time. For these reasons it was necessary to include "feedback" area as a variable in the test matrix.

The provision for variation of feedback consisted of a 4 in. diameter hole in the bottom of the plenum, in parallel with the valve opening. Sharp edged orifices from 2 in. diameter down (a total of 6 sizes) were fitted over this opening one at a time. A thin rubber seal ring was installed near the outer edge of the valve disk to assure that all the "leakage" flow was through the feedback orifice.

In the development of the equation of motion of the valve, the force on the valve in the closed position was based on lubrication flow below the disk. Thus, the equation does not represent the configuration, or the operating characteristics, of the experimental device. For the same reason the design values for the spring constant and damping coefficient given in Table 3-1 are of no direct significance.

A complete report of the experimental program is presented as Appendix A. Included is a description of the complete test device with both drawings and photographs. The test procedure is described in detail and the test results are tabulated. The opening and closing times are presented graphically as functions of the design characteristics of the valve systems - area ratio, spring constant, and damping coefficient. The Appendix also contains some general observations and a brief discussion. The significant results are reviewed and discussed further in Section IV.

SECTION IV DISCUSSION

As noted in par. 3-2, neither the earlier analytical investigations nor the test plan as originally proposed included the "feedback" flow area as a variable parameter. To provide the required control over this parameter in the test device it was necessary to prevent leakage past the closed valve. As a result the lubrication flow under the disk that had been postulated in the analysis could not occur. Inasmuch as the pressure profile due to this flow below the disk had been included in the development of design values for the spring constant K and the damping coefficient C_f , there is no reason to expect the dynamic characteristics of the test device to confirm the equation of motion. Nevertheless, the testing did confirm, at least qualitatively, the effect of these design parameters.

Within the ranges of values of all the parameters in the test matrix, there was found a group for which operation was satisfactory. Satisfactory operation means that within a short period following venting of the jupe (opening of the dump valve), the valve closes; and that after the dump valve is closed, the valve reopens without undue delay. Inasmuch as the range of pressures tested was larger than is projected for an operational device, there remains no doubt that the PMV can be developed to perform satisfactorily in the ACB jupe installation.

Because the air-supply-fan pressure/flow rate characteristics were not scaled directly, the test results cannot be extrapolated to represent the dynamic characteristics of the valve in a full-scale installation. Unfortunately, even had such an extrapolation been possible, there is no objective basis for evaluation of the adequacy of performance. Specifically, what are the limits on acceptable response times for valve closure following jupe venting, or valve opening following resealing of the jupe?

Among other things the latter question introduces the problem of scaling of fabric structures such as ACV skirts or jupes. The materials commonly used are usually characterized as being flexible and inelastic. The flexibility is provided by the weave; the inelasticity is only relative, but it is probably realistic considering the relative low pressure loadings. However, the base material, be it nylon or other cloth, must be coated to make it air-tight. This coating does not contribute significantly to the strength characteristics, but it will affect the flexibility. Further, the amount of coating necessary to seal the woven cloth is not necessarily proportional directly to the thickness of the base material. Thus, the relationships between the weight and flexibility characteristics of coated cloths of different thicknesses, hence strengths, will not necessarily be consistent with their respective strengths. Therefore, careful consideration must be given to the selection of flexible materials when dynamic similarity is required. However, the contribution of the stiffness and elasticity of the fabric structure of a model commonly is at most a second-order effect. Of much more importance to the reproduction of true dynamic similarity is an accurate reproduction of the pressure/volume-flow-rate characteristic of the air supply system.

In the particular case of the ACB, the simulation of the air-supply characteristic would have required simulation of the total system upstream of the valve. This included not only the fan, but also the ducting and the plenum structure.

A scale reproduction of the ducting and plenum system designed for the ACB (Ref. 1) would not have provided scaled flow conditions unless a fluid other than air were used to obtain Reynolds number similarity. With a different fluid, the pressure/mass-flow characteristics would be even more difficult to reproduce. For these reasons it was not considered necessary, or even advisable, to reproduce the proposed full-scale installation any more closely than to scale the valve itself.

SECTION V
CONCLUSIONS

1. The Power Management Valve will function as proposed in the MERADCOM ACB, i.e., as a passive, automatic, device for the shut-off of air-flow into a jupe following dumping, or loss of cushion.

2. The experimental device was not able to provide true dynamic similarity with the proposed full-scale valve. Therefore, design values for the spring constant and damping ratio most appropriate for a full-scale valve could not be established by this test of a single valve.

3. Demonstration of the adequacy and acceptability of the dynamic behavior valve cannot be accomplished independent of the barge. The dynamic behavior of the full system, the mass and inertia of the barge and the air-supply system from fan to jupe, must be examined with and without the valve to demonstrate satisfactory performance.

SECTION VI
RECOMMENDATIONS

Prior to installation of the PMV in the ACB jupe system a large-scale model of four jupes with a common air-supply ducting and individual PMV's should be tested to investigate the dynamics of the complete system.

LIST OF SYMBOLS

A	Area, ft ²
A _D	Feedback orifice area, ft ²
A _i	Inlet orifice area, ft ²
A _O	Pressure relief orifice area, ft ²
C _f	Damping coefficient, lb-sec/ft or lb-sec/in.
C _h	Discharge coefficient, dimensionless
D	Diameter, in.
d	Diameter of PMV disk, in.
F	Force, lb
F _C	Force on PMV disk in closed position, lb
F _O	Force on PMV disk in open position, lb
h	Vertical displacement of PMV disk, ft
h _C	Height of PMV disk in open position, ft or in.
K	Spring constant, lb/ft or lb/in.
L	Characteristic length dimension, ft
M	Mass, slug
\dot{m}_O	Flow rate through feedback orifice, dump valve open, PMV closed, cfs
\dot{m}_{ic}	Flow rate into upper plenum, dump valve closed, cfs
\dot{m}_{Oc}	Flow rate out of upper plenum relief orifice, dump valve closed, cfs
\dot{m}_{OO}	Flow rate out of upper plenum relief orifice, dump valve open, cfs
P	Pressure, psf
P _a	Atmospheric pressure, psf
P _I	Impact pressure of PMV disk against seat, psf
P _L	Lower plenum pressure, dump valve closed, in. H ₂ O or psf
P _O	Upper plenum pressure, dump valve open, PMV closed, in. H ₂ O or psf
P _u	Upper plenum pressure, dump valve closed, in. H ₂ O or psf
R	Radius of PMV disk, in.
r _O	Radius of PMV orifice, in.
S	Scale factor, dimensionless
t	Time, sec
t _C	Time for PMV to close following opening of dump valve, sec

t_f Time from dump valve closing for lower plenum to reach pressure P_L , sec
 t_o Time from dump valve closing to start of PMV opening, sec
 V Airflow velocity, fps
 W Weight, lb
 α Constant in equation for F_c , dimensionless
 β Constant in equation for F_o , dimensionless
 γ Initial acceleration of PMV disk, F_o/M , ft/sec²
 ΔP Differential pressure, in. H₂O or psf
 λ Damping coefficient, $C_f/2M$, sec⁻¹
 ω Frequency, Hz
 ω_o Natural frequency, Hz

Subscripts

des Design
 fs Full scale
 m Model
 max Maximum
 min Minimum

Symbols - Data Sheets

C PMV did not close
 O PMV did not open

APPENDIX A

TEST REPORT

POWER MANAGEMENT VALVE

J. SLADKY, JR.
KINETICS INTERNATIONAL CORP.

CONTENTS - APPENDIX A

1. Objectives of Experiment
2. Description of Experimental Apparatus
3. Test Program
 - Test Sequence
 - Equations Pertinent to Air Mass Flow Data
4. Discussion of Results
5. Tabulated Data
6. Apparatus & Instrumentation
7. Strip Chart Records

1. OBJECTIVES

The experimental investigation was undertaken to evaluate the operation of a feed-back controlled check valve (Power Management Valve, PMV). The general objectives as defined in the test plan are:

- Provide information that will help determine if the theories developed by Forge Aerospace are sufficiently accurate for designing practical applications of the PMV concept.
- Develop a body of empirical data to be used in extending the concept to full scale designs.

More specifically the following items are addressed:

- Investigate the dynamic behavior of a Power Management Valve.
- Evaluate the operating characteristics of a PMV under conditions that simulate the operation of the Air Cushion Barge (i.e., sudden cushion venting).
- Obtain measurements of design and operating parameters of the PMV.

2. DESCRIPTION OF EXPERIMENTAL APPARATUS

Basic Test Cell

The general arrangement of the experimental cell is schematically illustrated in Figure 1. Figures 2a and 2b are photographs of the test cell unit in the open position and with the PMV Test Element installed, respectively.

The test cell device consists of two airtight box-like arrangements fabricated from 3/4" marine plywood. The upper half or upper plenum can be swung about on a piano hinge to reveal the test surface which in turn forms the top of the lower plenum (Figures 3 & 4). This surface (3/4" plywood) has two openings; one to accept the PMV test element and the other to allow insertion of various feedback orifice plates. The bottom of the lower plenum is equipped with a solenoid operated dump valve. The valve is fabricated in two parts. The fixed section is 3/4" marine plywood through which twelve slots each 2 x 13 1/2" are cut (Figure 5). A moveable section of 1/8" masonite similarly configured with perforations, is moved by an air operated solenoid controlled actuator. Operation of this valve alternatively closes and opens the bottom of the lower plenum chamber of the test cell (Figures 6 & 7). This action simulates the sudden venting of an ACV cushion system.

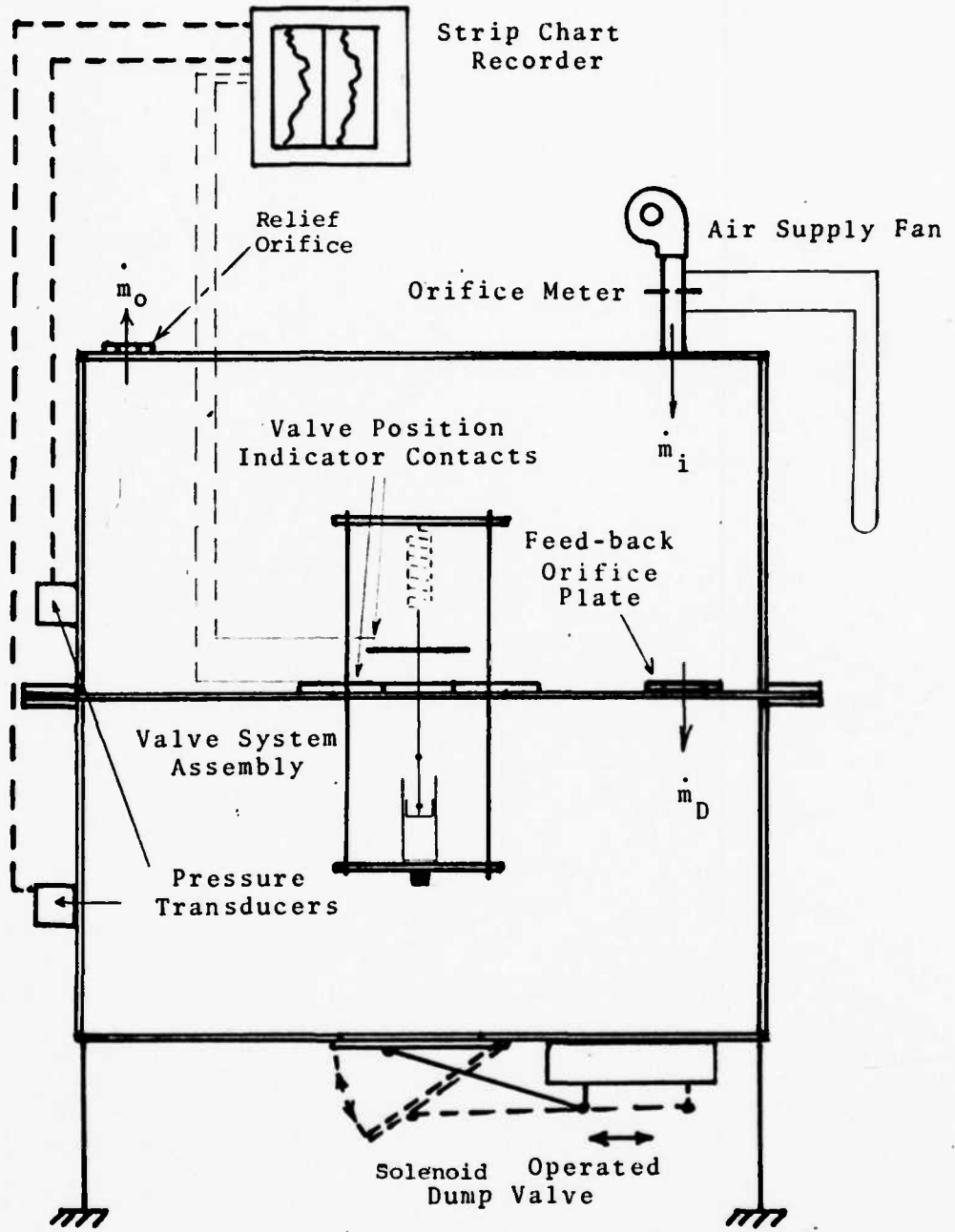

Figure 1. General Arrangement

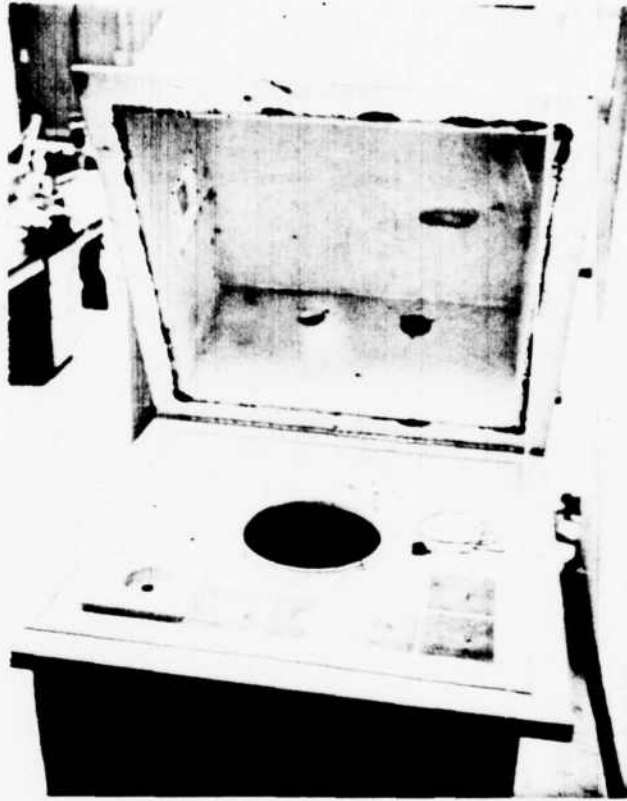

Figure 2a

Test Cell Open Prior to Installation
of PMV Test Element



Air Supply
Inlet

P.M.V. Test
Element
Installed in
Test Cell

Feed-back Orifice Position

Figure 2b. P.M.V. Test Element in Position

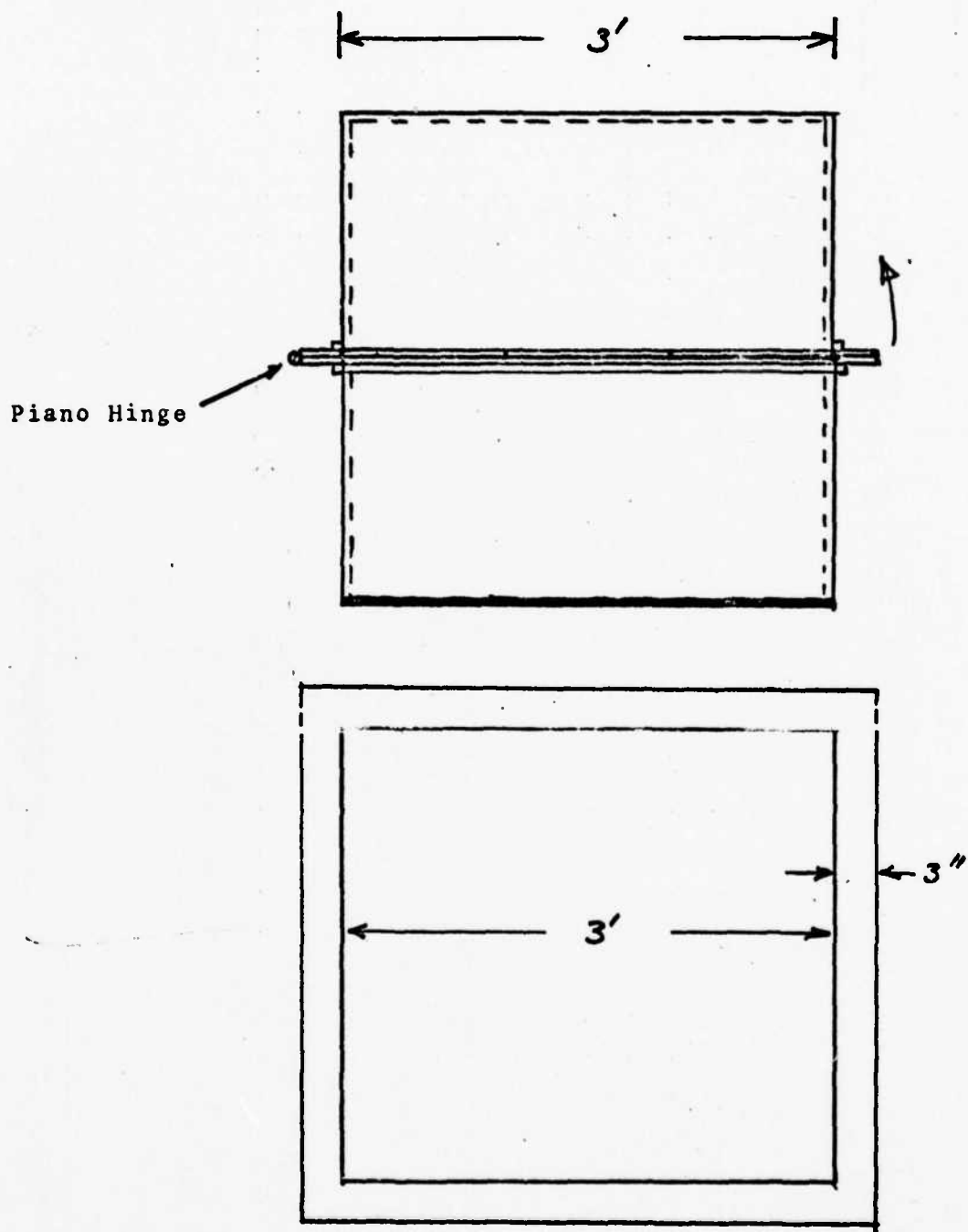

Figure 3. Basic Test Cell

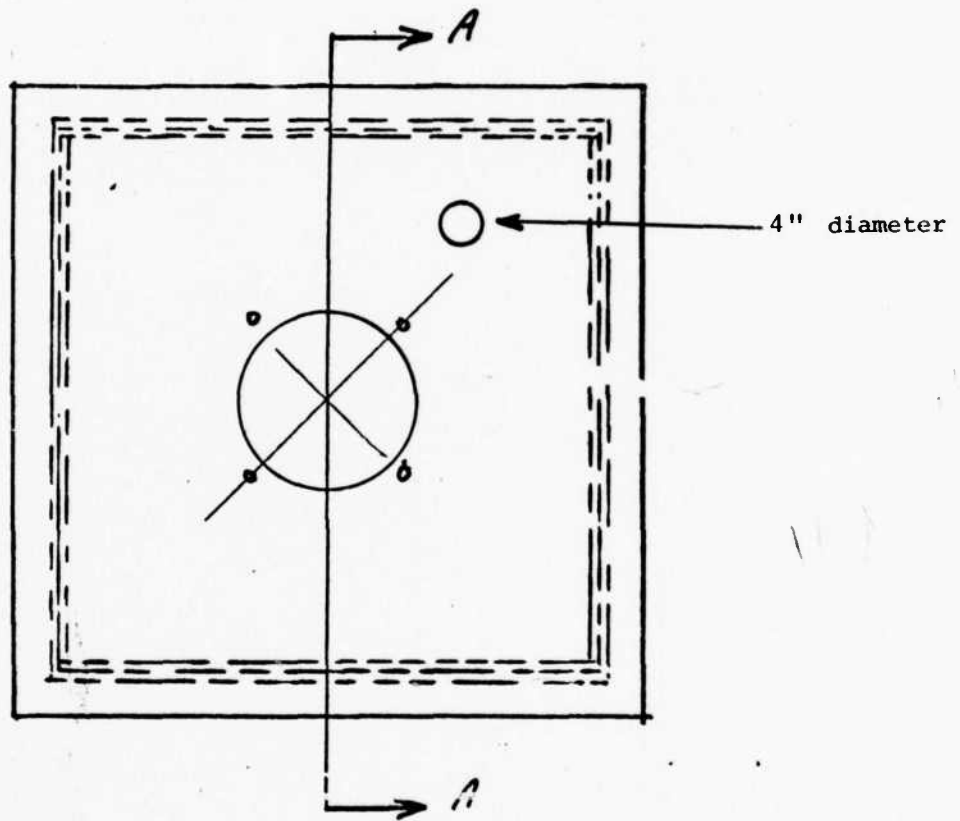

Figure 4. Test Surface

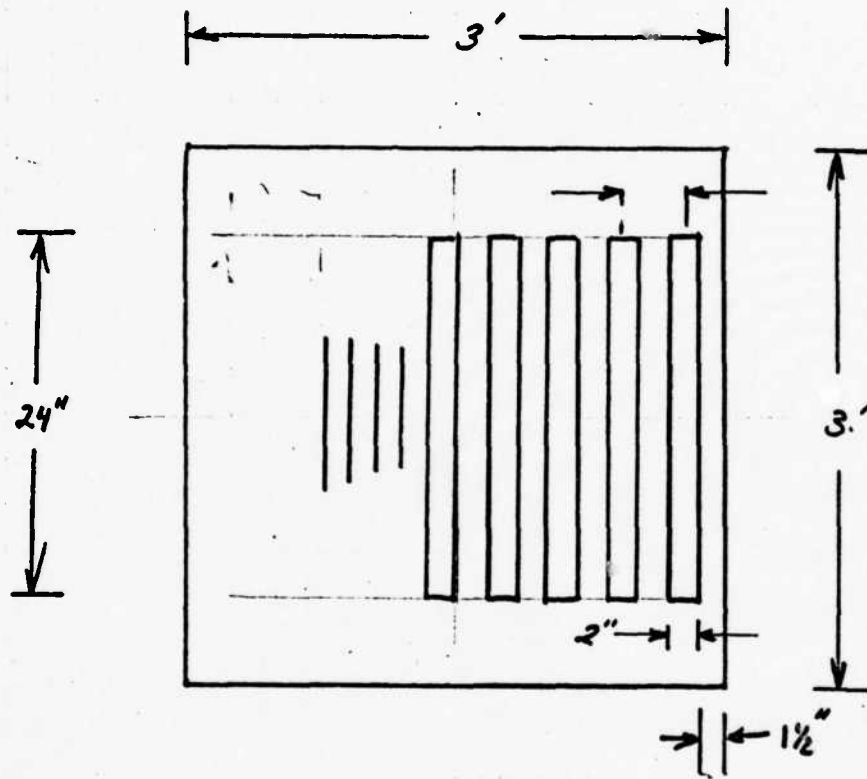

Figure 5. Dump Valve Geometry

Dump Valve Closed



Figure 6.

View Through Lower Plenum, Dump Valve Closed

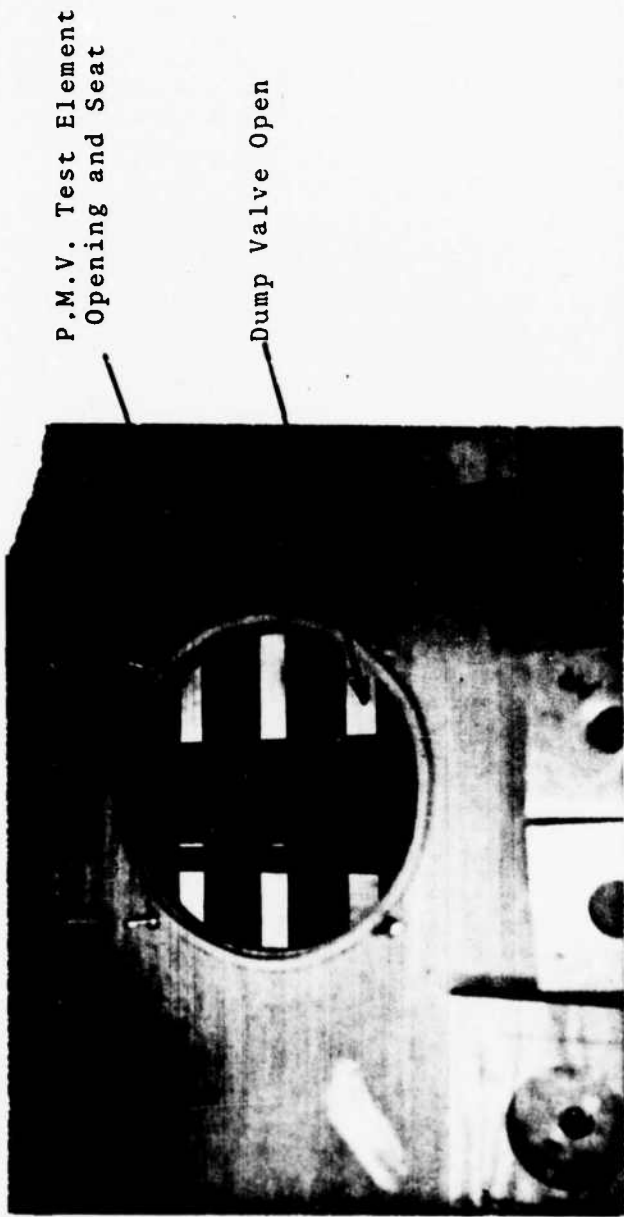
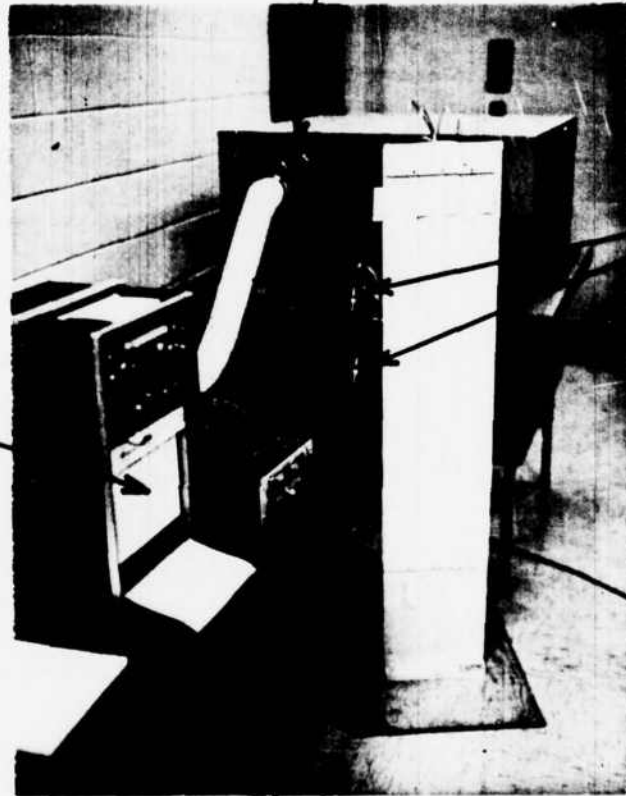

Figure 7.

View Through Lower Plenum, Dump Valve Open

Air Supply Orifice Meter

Pressure
& Valve
Position
Recorder



Pressure
Transducers

Pressure Transducer

Power Supply

Figure 8.

Test Cell and Instrumentation

Air Supply

The upper plenum chamber is provided with an air supply via a 4" diameter flexible duct. An industrial Clements Co. high energy blower is used to provide air to the test cell. The blower in turn is controlled independently by a standard Hewlett-Packard power controller (Figure 8). The air flow rate from the blower is measured by the use of a standard ASME orifice meter.

PMV Test Element

Figure 9 is a schematic of the PMV test element and Figure 10 illustrates the device just before insertion into the test cell. There are three subelements:

- Valve Disk. The valve disk is an eight inch (8") diameter x 1/16" thick aluminum sheet centrally supported by a 1/4" diameter valve guide shaft. The shaft is directed concentrically by upper and lower teflon guide bearings.
- Damper. The lower end of the shaft is attached to an 'Airpot' damper. The dashpot has provisions for adjustment of the damping coefficient.
- Spring. The entire moveable assembly, valve disk, shaft, and dashpot piston is suspended by means of an interchangeable tension type spring.

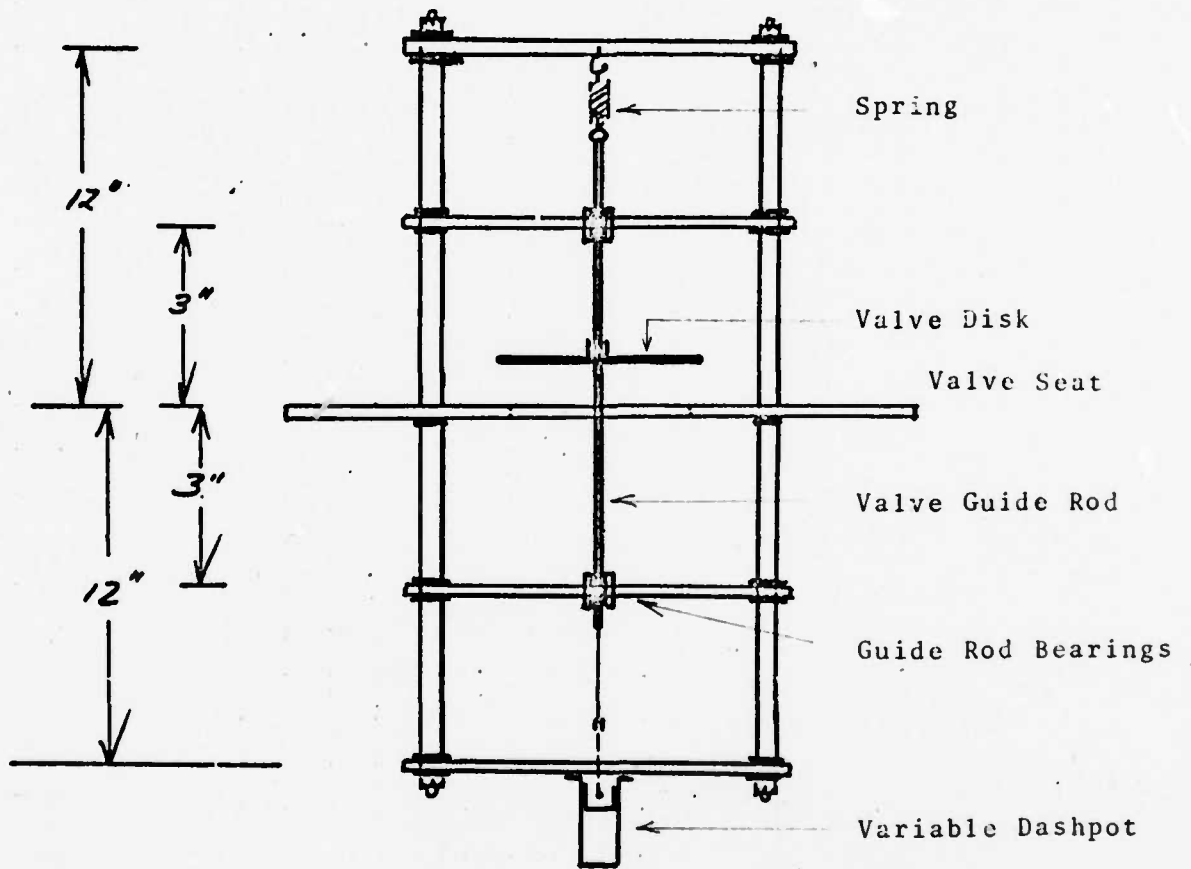

Figure 9. P.M.V. Test Element - Schematic

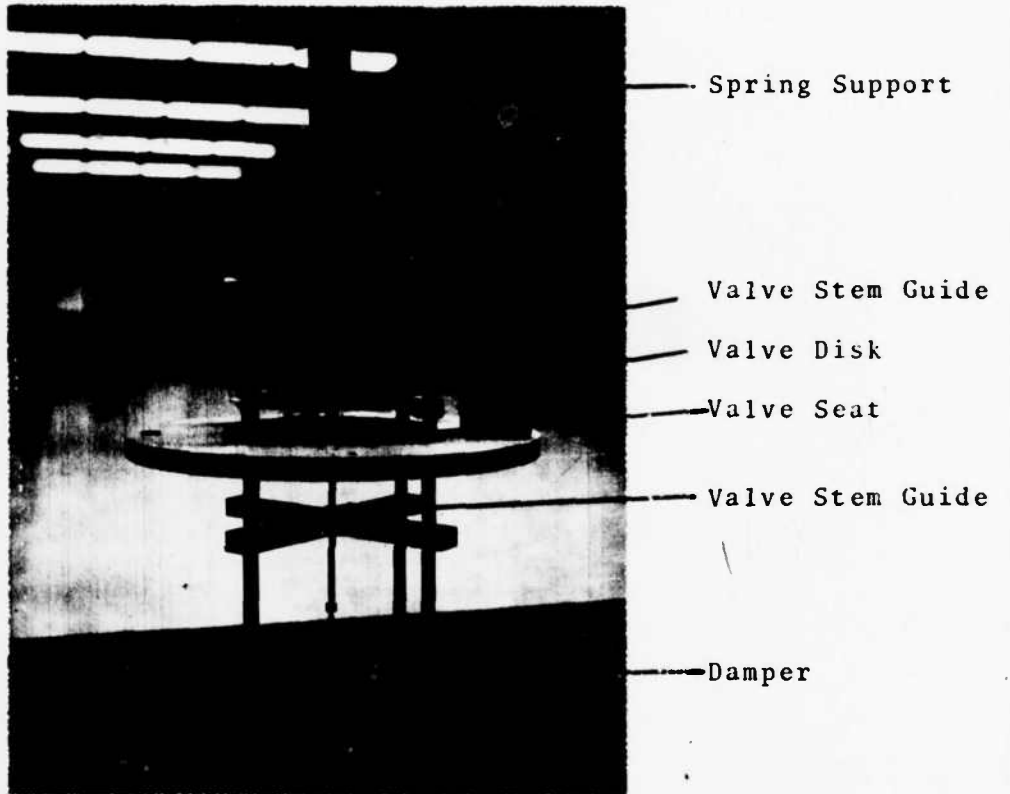

Figure 10. P.M.V. Test Element

The position of the PMV valve disk is identified at two points; maximum up or open and fully closed. Two electrical contacts located at maximum up travel and full down position activate the strip chart event marker. These two extreme positions were used only for the calibration of the damping coefficient setting where the full 1.45" stroke of the PMV was employed. During the dynamic tests the PMV valve disk was individually adjusted each time for a .75" stroke above the full closed position. Thus, only the bottom contact activated the recorder event marker.

TEST PROGRAM

Test Sequence

Each testing series was preceded by a procedure to check the level orientation of the test cell and the PMV test element. The integrity of all seals and joints was also periodically reviewed. The pressure transducers were calibrated before and after a testing sequence. Figure 12 is a calibration chart for the instrumentation used. The spring constant for the three springs employed in the test was obtained by applying a known load ($1/2$ and $1 \#_f$) and measuring the extension. This procedure was executed before and after the experiments.

The damper was then set at a particular adjustment and the PMV test element was installed in the test cell. Without the spring in place the valve disk was allowed to drop from its maximum up (open) to its closed position, a stroke distance of 1.45". The time of travel was recorded by the event marker on the strip chart which was set at 100 mm/sec. This damper calibration procedure was executed at the start and end of each damping coefficient series.

A spring of a known spring constant was then installed and the valve disk was adjusted to .75" above its full closed

position. A feedback orifice plate was installed and the test cell was then closed and locked. The fan air supply was activated. With the dump valve closed, the pressure within the test cell was brought up to a given value (4, 6, 8, in. H₂O).

Activation of the dump valve solenoid opens the lower plenum and vents it to atmosphere. The sequence of events is illustrated in Figure 11. The right hand recording is the pressure in the lower plenum and the left channel is the pressure trace in the upper plenum. At the instant that the dump valve opens pressure in both lower and upper plenums drops rapidly. From the trace it appears that there is some overexpansion and pressure wave resonation in the plenums. The closing of the PMV valve disk is indicated by a rightward movement of the left event marker. This indicates the instant when the valve has reached its full closed position. The time to close t_c is taken as the distance between the point when the dump valve is opened and the point where the event marker is activated. (For all tests the chart speed is 20 mm/sec.) Under certain parameter settings the PMV valve failed to operate (failed to close). In this case the pressures in the upper and lower plenums would drop to atmospheric values.

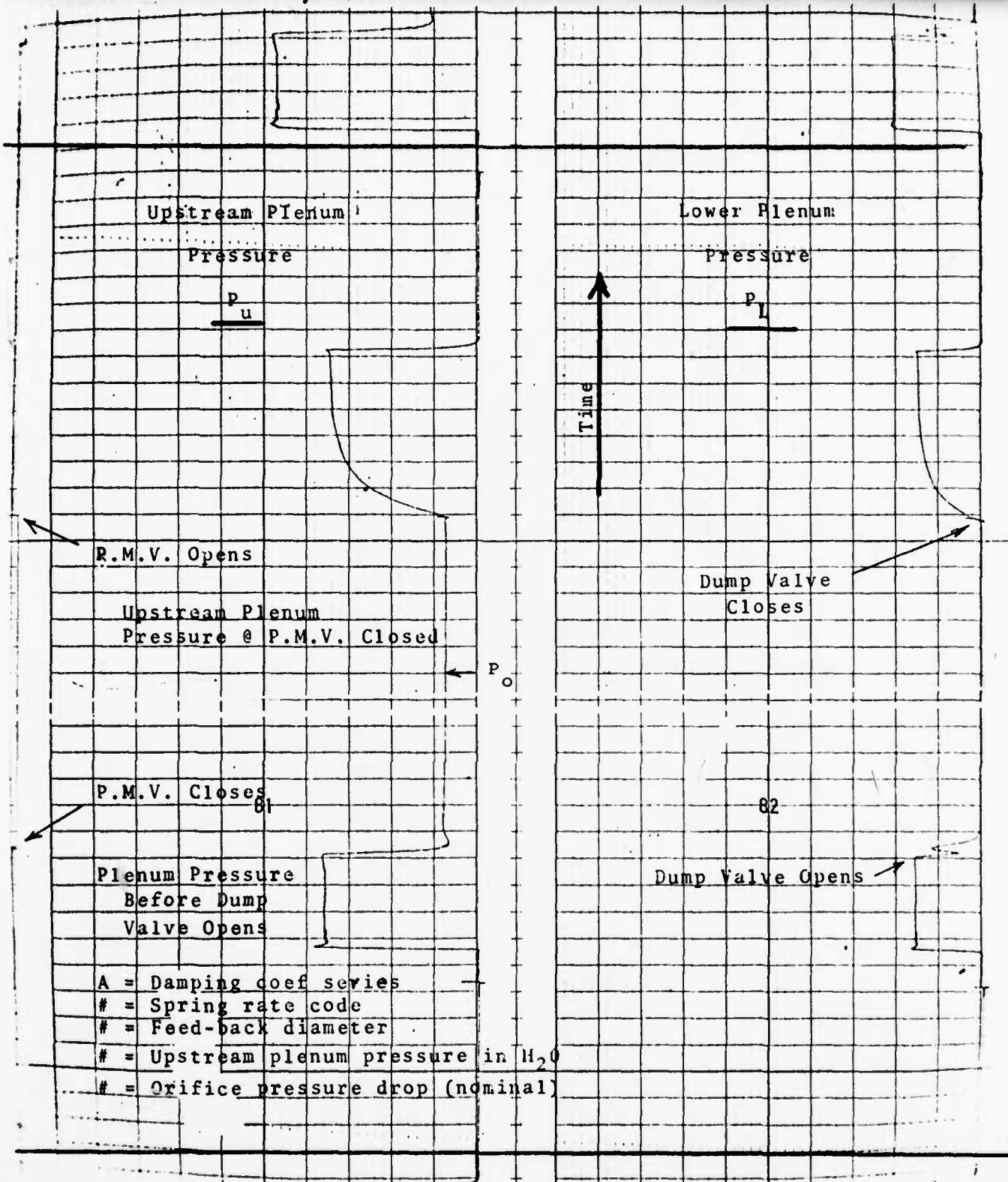

Figure 11. Sample Trace

PR-AM-10 X 10 10 1 INCH
10TH LINE HEAVY

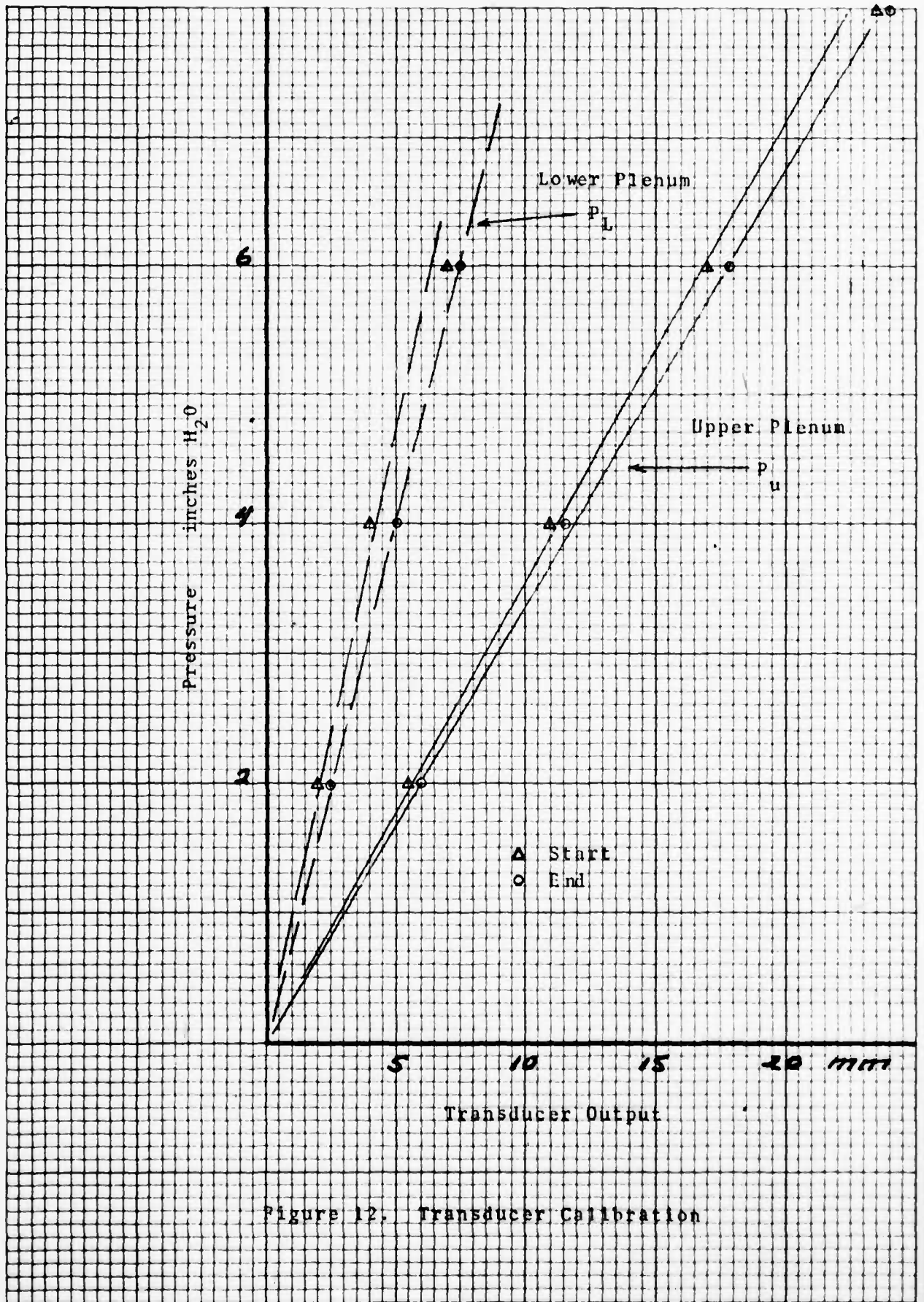

Figure 12. Transducer Calibration

The reverse procedure (PMV valve opening) begins with the activation of the dump valve solenoid and the resultant rapid closure of the dump valve. The pressure P_L in the lower plenum rises. When the lower plenum pressure is equal to the upper plenum intermediate pressure P_0 the PMV valve disk is subject only to forces resulting from the damper and the spring. The instant the valve disk breaks contact with the valve seat is recorded by a leftward movement of the left marker. The distance between dump valve closing and the event marker indent is designated 'closing' time t_c . The distance between dump valve closure and the asymptotic regain of the lower plenum pressure is designated as 'filling' time t_f . Again under certain parameter settings the PMV valve disk fails to open. In this case the lower plenum pressure remains at atmospheric and the upper plenum pressure maintains intermediate values P_0 . Each strip chart recording is also inscribed with the damper series designator (A, B, C), spring rate designator (1, 2, 3), feedback orifice diameter (2, 1 1/2, 1, 1/2, 1/4, 1/8), upper plenum pressure (4, 6, 8), and the manometer flow rate in H_2O ". The preceding sequence is then repeated for two other upper plenum pressures.

The test matrix is illustrated in Figure 13. Each of three damping coefficients was tested with three spring rates, six feedback orifices and three upper plenum pressures. Feedback orifice sizes where the PMV valve disk failed to close or open were neglected.

TEST SEQUENCE

Damper Coefficient
(3 Series)



Spring Constant
(3 Series)



Feedback Orifice
(6 Sizes)



Upper Plenum Pressure
(3 Values)

Figure 13. Test Sequence

EQUATIONS PERTINENT TO AIR MASS FLOW DATA

1. Upper Plenum Inflow Rate:

A. Dump valve closed

$$\begin{aligned}\dot{m}_{ic} &= C_h \cdot A_i \cdot V \\ &= 0.66 \cdot 0.017 \cdot 66.16 \sqrt{\Delta P(H_2O)} \\ &= 0.742 \sqrt{\Delta P(H_2O)} \quad , \text{ cfs}\end{aligned}$$

Where

$$A_i = \text{Inlet orifice area} = 0.011 \text{ ft}^2$$

$$C_h = \text{Discharge Coefficient} = 0.66$$

$$\dot{m}_{ic} = \text{Flow rate into upper plenum, dump valve closed, cfs}$$

$$V = \text{Flow velocity} = \sqrt{2 \cdot 5.2 \Delta P / \rho} \quad . \text{ fps}$$

$$\Delta P = \text{Pressure drop across ASME inlet orifice, in. } H_2O$$

B. Dump valve open

$$\dot{m}_{io} = \dot{m}_{oo} + \dot{m}_{do}$$

Where

$$\dot{m}_{do} = \text{Flow rate through feedback orifice, dump valve open, PMV closed, cfs}$$

$$\dot{m}_{io} = \text{Flow rate into upper plenum, dump valve open, cfs}$$

$$\dot{m}_{oo} = \text{Flow rate out of upper plenum relief orifice, dump valve open, cfs}$$

2. Upper Plenum Outflow Rate:

A. Dump valve closed

$$\begin{aligned}\dot{m}_{oc} &= C_h \cdot A_o \cdot V \\ &= 0.89 \cdot 0.10 \cdot 29 \sqrt{P_u \text{ (psf)}} \\ &= 0.257 \sqrt{P_u \text{ (psf)}}, \text{ cfs}\end{aligned}$$

Where

$$A_o = \text{Relief orifice area} = 0.010 \text{ ft}^2$$

C_h = Discharge coefficient = 0.89

\dot{m}_{OC} = Flow out of upper plenum relief orifice, dump valve closed, cfs

V = Flow velocity = $\sqrt{2 P_u / \rho}$, fps

P_u = Upper plenum pressure, dump valve closed, psf

B. Dump valve open

$$\begin{aligned}\dot{m}_{OO} &= C_h \cdot A_o \cdot V \\ &= 0.257 \sqrt{P_o} \text{ (psf)}, \text{ cfs}\end{aligned}$$

Where

\dot{m}_{OO} = Flow rate out of upper plenum relief orifice, dump valve open, cfs

P_o = Upper plenum pressure, dump valve open, psf

3. Feedback Orifice Flow Rate:

$$\begin{aligned}\dot{m}_{Do} &= C_h \cdot A_D \cdot V \\ &= 0.62 \cdot A_D \cdot 29 \sqrt{P_o} \text{ (psf)} \\ &= 17.9 A_D \sqrt{P_o} \text{ (psf)}, \text{ cfs}\end{aligned}$$

Where

A_D = Feedback orifice area, ft²

C_h = Discharge coefficient = 0.617

4. Discussion

General Observations

During the operation of the experiment there were observed three classes of phenomena with respect to the motion of the PMV test element. On cycling of the dump valve (open and closed) one of the following would occur:

- The PMV valve disk would fail to close. The direct cause of this was the failure to establish a sufficiently large pressure difference across the valve disk to overcome the force generated by the suspension spring. This in turn was the result of the large air bleed rate through the feedback orifice. Failure to close was experienced, as would be expected, with the largest feedback openings. This operation is indicated by a NC on the strip chart record and by a C in column 1 of the tabulated data.
- The PMV valve disk would close on the opening of the dump valve and then open on dump valve closing. This was the desired sequence of PMV operation.
- The PMV valve disk would close on dump valve opening but fail to open on dump valve closing. This in essence is the reverse of case one above. The force due to the pressure difference across the valve disk

is greater than the force developed by the suspension spring. Failure to open was experienced with the smallest feedback hole sizes. This failure is indicated on the strip chart record by a NO and by an O in column 1 of the tabulated data.

There then appears to be a band of feedback orifice sizes in which full PMV operation can be maintained. This operating regime appears to be sensitive to both the damping coefficient and to the spring rate of the suspension spring. In general, the valve disk failed to open when the area ratio $A_r > 30$. The area ratio A_r is defined as the ratio of the valve disk flow area πd^2 divided by the area of the feedback orifice.

Discussion

The variables in the subject experiment are: upper plenum pressure P_u , lower plenum pressure P_L , intermediate upper plenum pressure P_o , area ratio, damping coefficient C_f , spring rate K , and closing t_c and opening t_o times respectively. It is difficult to determine in what combinations or nondimensional form these should be formulated in order that they be most directly useful in future development of the PMV concept.

It is apparent that the dominant parameter in the PMV valve closing is the upper plenum pressure particularly that pressure (P_o) when the lower plenum is vented. The relationship between the area ratio A_r and the pressure ratio P_r (defined as P_u/P_o),

P_0 being the upper plenum pressure when the dump valve is opened, is illustrated in Figure 14. For the largest orifice diameter (2") the PMV disk consistently closed only when the softest spring rate (K_3) was used. On the otherhand, the PMV disk opened for the 1/2" diameter feedback orifice only when the highest spring rates (K_1) were used. It should be noted that spring rates required for satisfactory opening and closing are counter to each other; i.e., a soft spring for low pressure closure and a stiff spring for high pressure opening. At the extreme bypass orifice sizes one precludes the other.

Figure 15 illustrates the relationship between the initial upper plenum pressure P_u and the PMV disk closing time for the softest spring rate K_3 . It is observed that closure times are less sensitive to the area ratio A_r than the damping coefficient. The negative slope of the curves with respect to the increasing upper plenum pressure is as would be expected.

Figure 16 relates closure times to upper plenum pressure P_u for a constant area ratio $A_r = 10.6$. For a given upper plenum pressure the closing times are dominated by the damping coefficients and to a lesser degree by the suspension spring rates. For a given damping coefficient closing times are inversely proportional to spring stiffness.

Figures 17 and 18 illustrate the PMV disk opening time frames. In the opening sequence the effects of the various parameters on the disk operation is less clear. Figure 17 is

for a constant spring rate K_3 . It appears that for a given damping coefficient the dominant parameter is the area ratio A_T . In the opening sequence the time actually represents the lower plenum filling process. Hence the relative insensitivity to the damping coefficient is acceptable.

FR. NO. 10 X 10 TO 1 INCH
10TH LINE HEAVY

Fig 1A

PRESSURE RATIO P
VS
AREA RATIO A_r

Pressure Ratio
 P/P_0

Bypass Orifice Diameter

A_r
Area Ratio

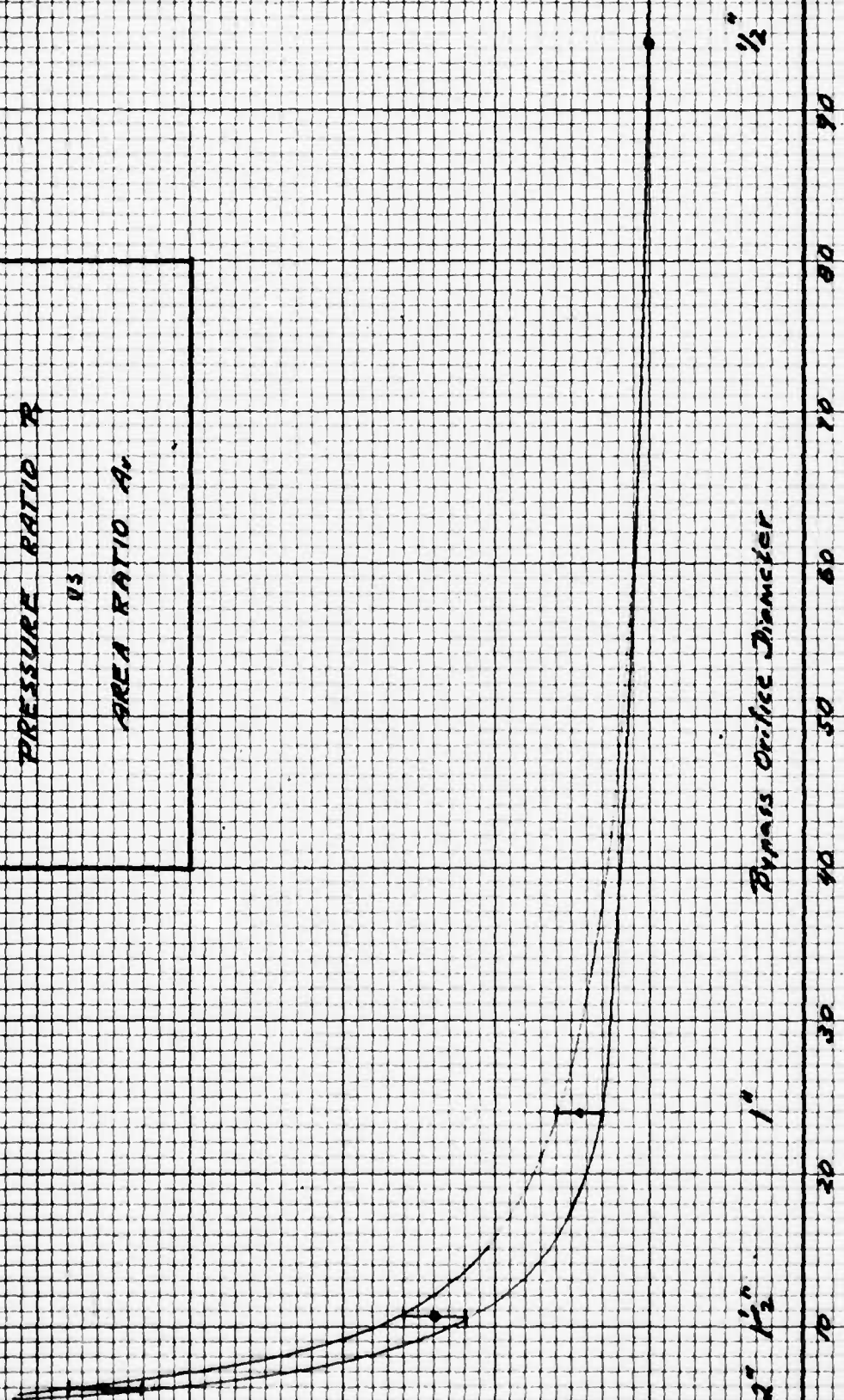
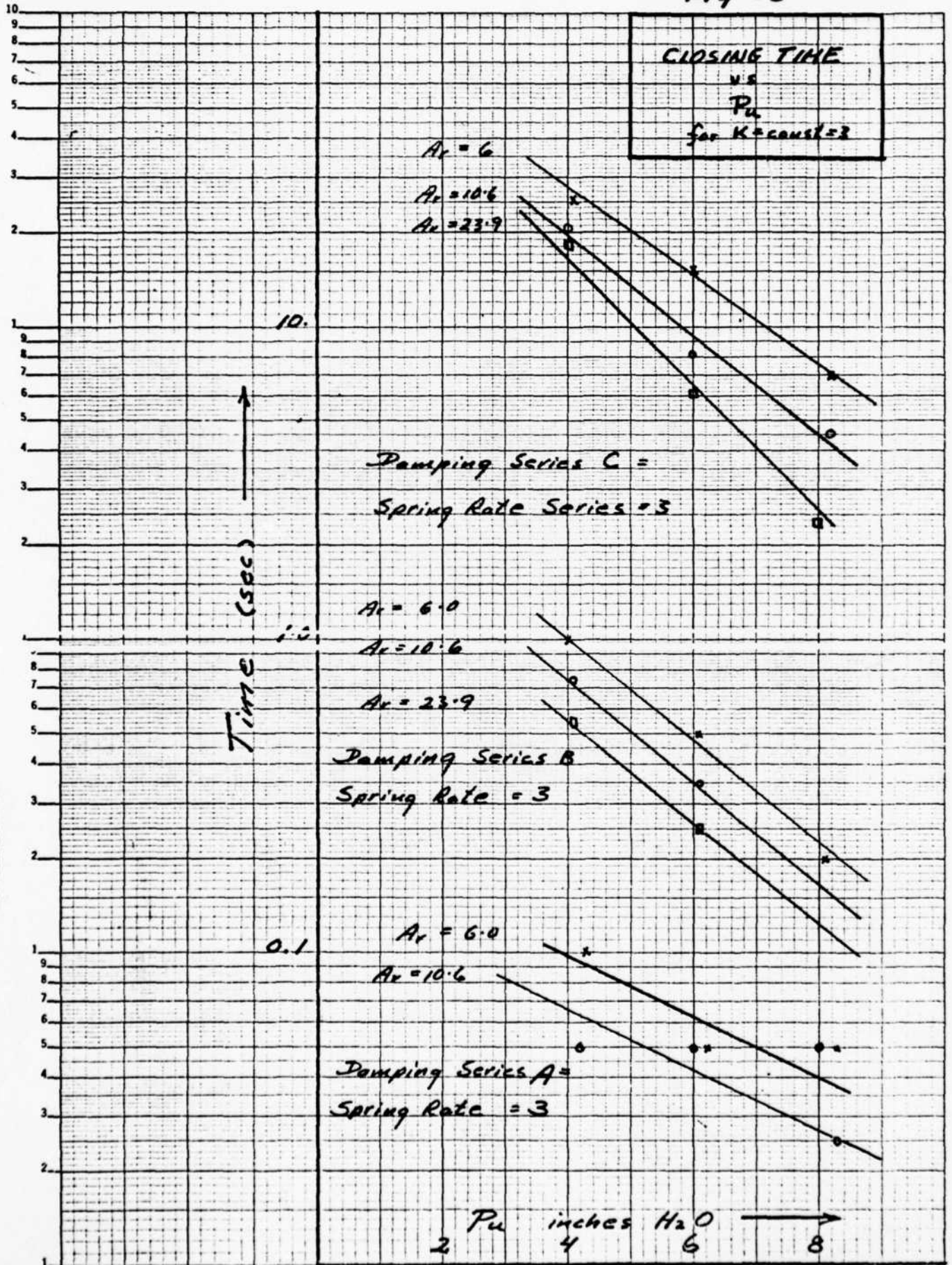
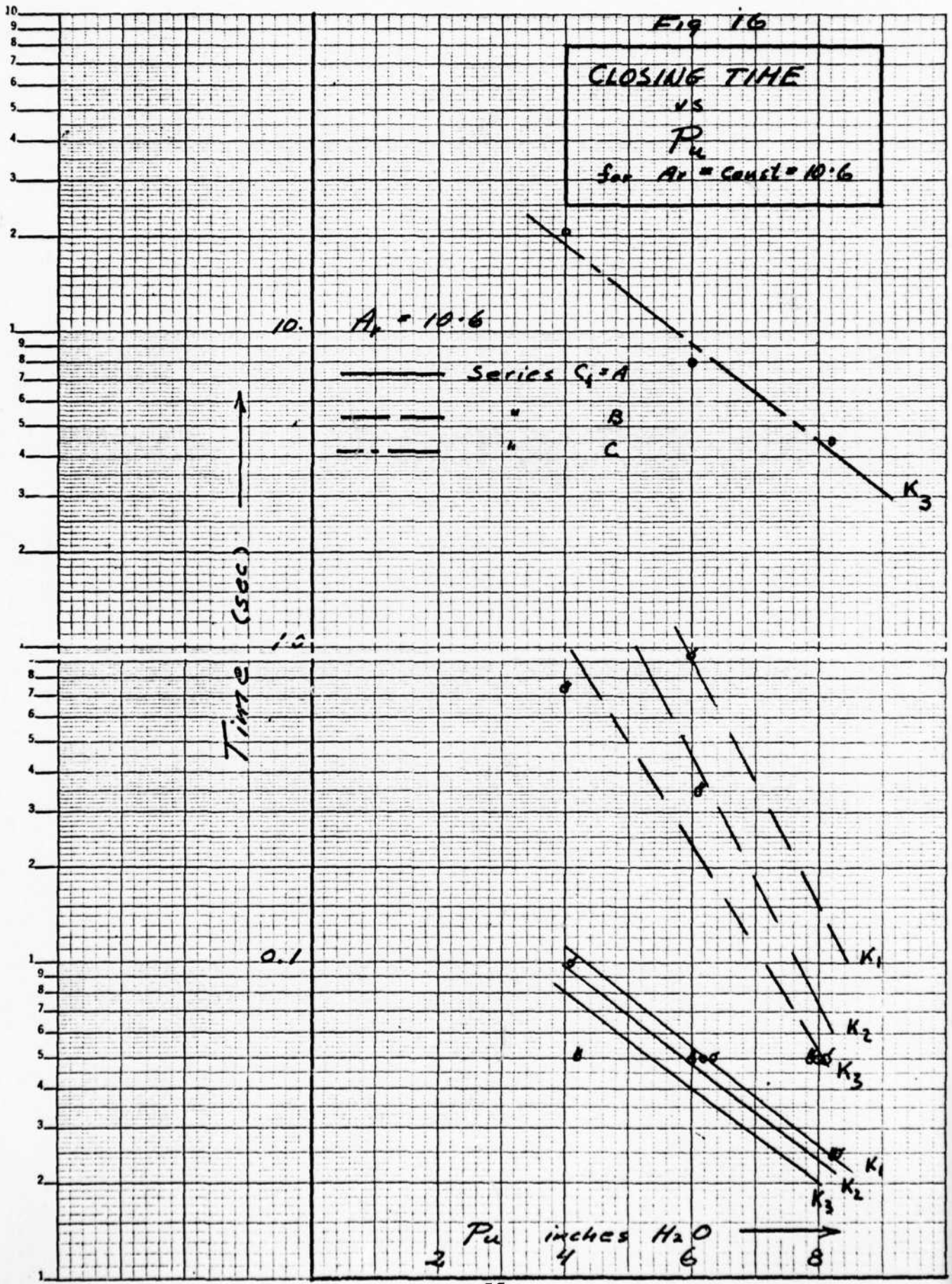

Fig 15



KEUFFEL & ESSER CO.
 4 CYCLES X 70 DIVISIONS
 MADE IN U.S.A.

KEUFFEL & ESSER CO. SEMI-LOGARITHMIC 46 6010
 4 CYCLES X 70 DIVISIONS
 KEUFFEL & ESSER CO.



46 6010 SEMI-LOGARITHMIC
 4 CYCLES X 70 DIVISIONS
 KEUFFEL & ESSER CO.

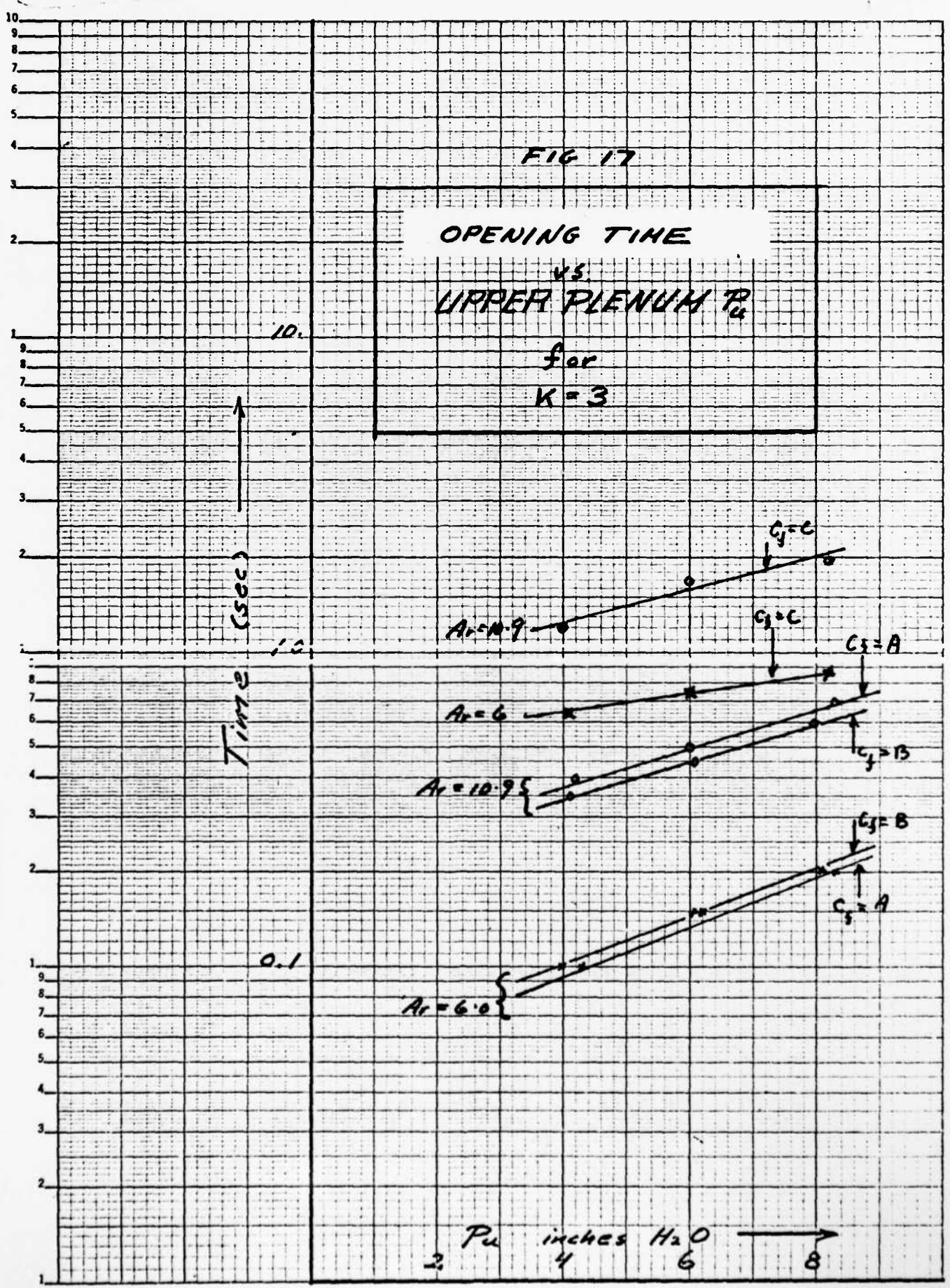
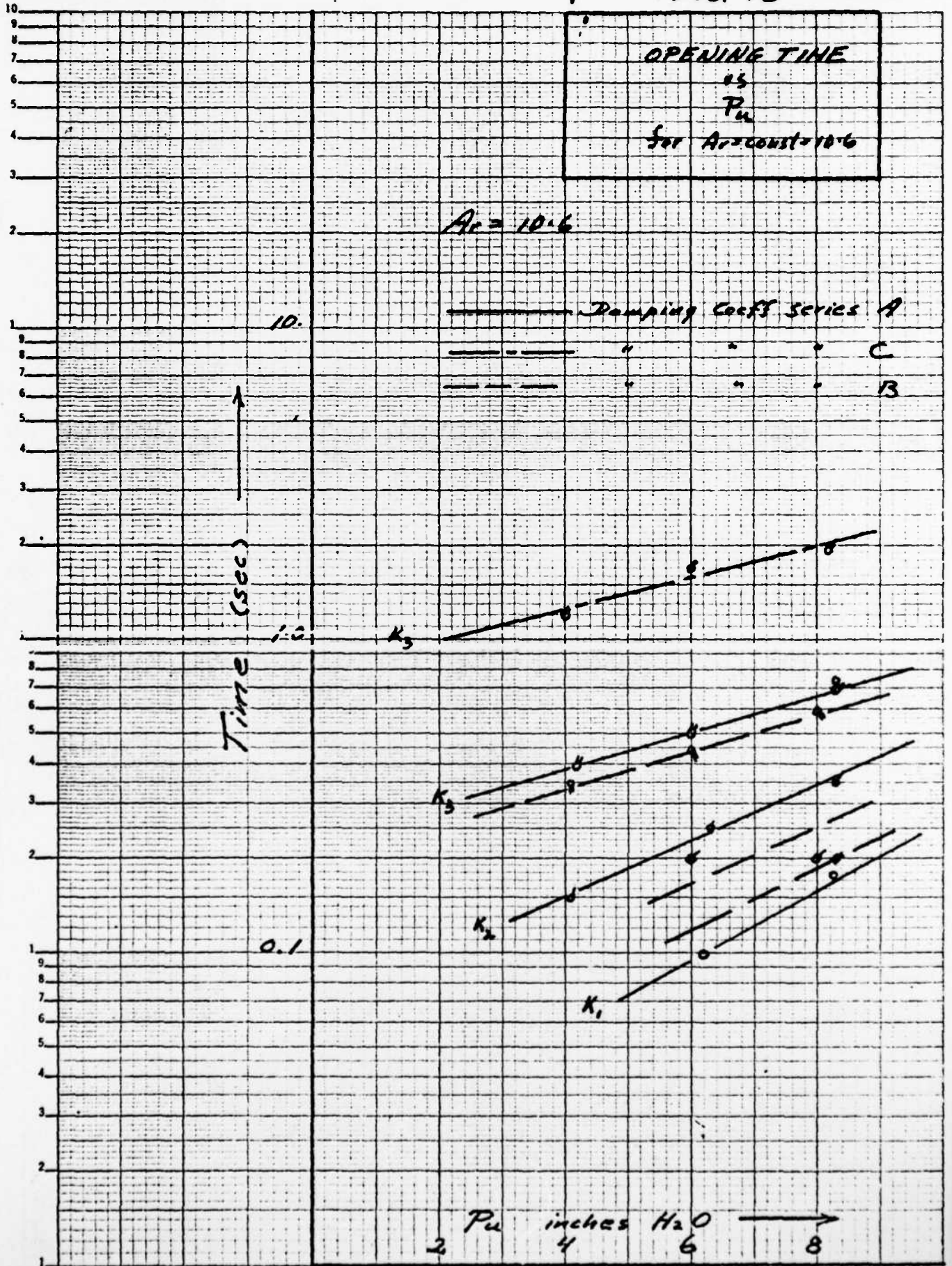

FIG. 18



SEMI-LOGARITHMIC 40 DIV. 4 CYCLES X 72 DIVISIONS MADE IN U.S.A. KEUFFEL & ESSER CO.

6. TABULATED DATA

KINETICS INTERNATIONAL CORP.

845 Holly Drive S., Annapolis, Maryland 21401

$K = 1$

Series = A

D	in	ft ²	P ₂ in H ₂ O	P ₁ psf	P ₂ in H ₂ O	P ₁ psf	t _c mm	t _c sec	Z ₀ mm	Z ₀ sec	Z _f in H ₂ O	Z _f sec	Z _f in H ₂ O	m ₁₆ cfs	m ₁₆ cfs	m ₃₀ cfs	m ₃₀ cfs	m ₁₈₀ cfs	m ₁₈₀ cfs	P ₂
	1	2	3	4	5	6	7	8	9	10	11	12	13	14	15	16	17	18	19	
	26	.022	4.1	21.3	0	0	-	-	-	-	20	1.0	-	-	0	0	0	0	-	
			6.3	32.8	1.2	6.2	1.0	.05	0	0	15	.75	4.1	1.0	.64	.971	1.61	5.3		
			8.0	41.6	1.7	8.8	0.5	.025	0.5	.025	30	1.5	5.5	1.15	.76	1.16	1.92	4.72		
	1 1/2	.012	4.0	20.8	0	0	-	-	-	-	20	1.0	2.9	.84	0	0	0	0	-	
			6.2	32.2	2.8	14.7	1.0	.05	2.0	.10	20	1.0	4.0	.98	.98	.84	1.82	2.2		
			8.3	43.2	3.5	18.2	2.0	.10	3.5	.175	20	1.0	5.8	1.18	1.1	.94	2.04	2.37		
	1	.0054	4.1	21.3	3.1	16.1	3.0	.15	13.0	.65	15	.75	2.8	.82	1.0	.39	1.39	1.32		
			6.3	32.8	4.4	22.9	1.0	.05	19.0	.95	20	1.0	4.2	1.00	1.23	.47	1.70	1.43		
			8.0	41.6	5.9	30.7	1.0	.05	29.0	1.45	30	1.5	5.5	1.15	1.42	.54	1.96	1.96		
	1/20	.0014	4.1	21.3	4.6	24.0	2.0	.1	∞	∞	0	0	2.7	.81	1.19	.12	1.38	-		
			6																	
			8																	
	1/4	3.4 x 10 ⁻⁴	4																	
			6																	
			8																	
	1/8	.8 x 10 ⁻⁴	4																	
			6																	
			8																	



KINETICS INTERNATIONAL CORP.
845 Holly Drive S., Annapolis, Maryland 21401

$\chi = 2$

Series = A

D	Ab	P _u	P _u	P _u	P _u	P _u	P _u	t _c	t _c	t _c	t ₁	m ₁₂	Mic	Mic	Mic	Mic	Mic	Mic	Pr
in	ft ²	in ²	psf	in ²	psf	in ²	psf	mm	sec	mm	sec	H ₂ O	cfs	cfs	cfs	cfs	cfs	cfs	cfs
1	2	3	4	5	6	7	8	9	10	11	12	13	14	15	16	17	18		
2	.022	4.3	22.3	1.0	5.5	2.0	.1	0	0	1.0	.75	2.9	.84	1.21	.80	.91	1.51	4.05	
		6.4	33.3	1.4	7.3	1.0	.05	1.0	.05	1.0	1.0	4.0	1.0	1.48	.76	1.05	1.75	4.56	
		8	41.6	1.7	8.84	0	0	2.0	.1	2.0	1.5	5.1	1.11	1.65	.76	1.16	1.92	4.70	
1/2	.012	4.1	21.3	1.7	6.84	2.0	.1	3.0	.15	3.0	1.0	2.9	.84	1.19	.76	.65	1.41	2.4	
		6.3	32.5	1.6	8.32	1.0	.05	5.0	.25	5.0	.75	4.4	2.16	1.46	.74	.63	1.37	3.94	
		8.3	43.2	5.5	18.2	.5	.025	7.0	.35	7.0	1.0	6.1	3.00	1.69	1.10	.94	2.04	2.4	
1-0	.0054	4.3	22.3	3.1	14.1	1.0	.05	10	1.0	10	1.25	2.8	.83	1.21	1.05	.39	1.42	1.38	
		6																	
		8																	
1/2	.0014	4																	
		6																	
		8																	
1/4	3.4 x10 ⁻⁴	4																	
		6																	
		8																	
1/8	.8 x10 ⁻⁴	4																	
		6																	
		8																	



$K = 3$

Series = A

D in	A ₀ ft ²	P ₂		P ₁		P ₀		Z _c mm	Z _c sec	Z ₀ mm	Z ₀ sec	Z _f mm	Z _f sec	m ₁₀ H ₂ O	m ₁₀		m ₁₀		m ₁₀		P ₁	
		in ₁₀	psf	in ₁₀	psf	in ₁₀	psf								cfs	min	cfs	min	cfs	min		cfs
1	2	3	4	5	6	7	8	9	10	11	12	13	14	15	16	17	18					
2	.022	4.3	22.3	1.0	5.2	2.0	.1	2.0	.10	2.0	.10	2.8	.82	.121	.59	.57	1.90	4.28				
		6.2	32.2	1.4	7.3	1.0	.05	3.0	.15	3.0	.15	4.4	1.03	1.46	.69	1.05	1.74	4.4				
		8.3	43.2	1.75	9.1	1.0	.05	4.0	.20	4.0	.20	5.8	1.18	1.69	.78	1.18	1.96	4.74				
1 1/2	.012	4.2	21.8	1.7	8.84	1.0	.05	8.0	.40	8.0	.40	2.7	.81	1.2	.764	.653	1.42	2.47				
		6	31.2	2.4	12.5	1.0	.05	10.0	.50	10.0	.50	4.2	1.01	1.45	.91	.78	1.68	2.5				
		8.3	43.2	3.5	18.2	.5	.025	14.0	.70	14.0	.70	5.6	1.16	1.69	1.1	.94	2.04	2.37				
4-8	.0054	4.2	21.8	1.9	9.9	1.0	.05	∞	∞	∞	∞	2.8	.82	1.20	.80	.30	1.10	2.20				
		6																				
		8																				
1/2	.0014	4																				
		6																				
		8																				
1/4	3.4 x 10 ⁻⁴	4																				
		6																				
		8																				
1/8	.8 x 10 ⁻⁴	4																				
		6																				
		8																				

KINETICS INTERNATIONAL CORP.

845 Holly Drive S., Annapolis, Maryland 21401

$K = 1$

Series = B

D in	Ad ft ²	P ₂ in H ₂ O	P ₁ psf	P ₂ in H ₂ O	P ₁ psf	P ₂ psf	t _c mm	t _c sec	t ₀ mm	t ₀ sec	Z _F in	Z _F mm	Z _F sec	t _T sec	m _{H₂O} H ₂ O	m _{air} air	m _{air} cfs	m _{H₂O} H ₂ O	m _{H₂O} cfs	m _{air} air	m _{air} cfs	P _T	
																							14
2c	.022	4.4	22.9	0	0	0	7	8	9	10	14	14	.7	2.9	.84	1.23	0	0	0	0	0	0	
C		6.1	31.7	0	0	0					32	32	1.6	4.1	1.0	1.45	0	0	0	0	0	0	
C		8.3	43.2	0	0	0					45	45	2.25	5.7	1.17	1.69	0	0	0	0	0	0	
1/2c	.012	4.1	21.3	0	0	0					21	21	1.05	2.8	.84	1.19	0	0	0	0	0	0	
C		6	31.2	0	0	0					27	27	1.35	4.1	1.0	1.45	0	0	0	0	0	0	
		8.3	43.2	3.6	18.7	18.7	1	.05	4	.20	28	28	1.4	5.8	1.18	1.69	1.11	.95	2.06	2.06	2.06	2.31	
1-c	.0054	4.1	21.3	0	0	0					21	21	1.05	2.7	.83	1.19	0	0	0	0	0	0	
C		6.1	31.7	0	0	0					35	35	1.75	4.1	1.0	1.45	0	0	0	0	0	0	
		8	41.6	5.5	28.6	28.6	1	.05	26	1.3	28	28	1.4	5.5	1.17	1.65	1.37	.52	1.89	1.89	1.89	1.45	
1/2-c	.0014	4.1	21.3	0	0	0					15	15	.75	2.9	.84	1.19	0	0	0	0	0	0	
D		6.1	31.7	6.1	31.7	31.7					40	40	∞	4.1	1.0	1.45	1.45	.14	1.59	1.59	1.59	1.45	
1/4	3.4 x 10 ⁻⁴	4																					
1/8	.8 x 10 ⁻⁴	4																					
		6																					
		8																					



$K = 2$

Series = B

D in	Ad ft ²	P ₁		P ₂		P ₃		t _c mm	t _c sec	z ₀ mm	z ₀ sec	z _f mm	z _f sec	t _f sec	m _{1c} H ₂ O	m _{1c} cfs	m _{2c} cfs	m _{2c} cfs	m _{3c} cfs	m _{3c} cfs	P ₁	
		in H ₂ O	psf	in H ₂ O	psf	in H ₂ O	psf															
2-C	.022	3	4	5	6	7	8	9	10				20	1.0	2.9	.54	1.19	0	0	0	0	
-C		6.1	8.7	0	0							27	1.35	4.1	1.0	1.45	0	0	0	0		
1 1/2-C	.012	8	8.6	1.7	8.8	8	.4	4	.2			25	1.25	5.5	1.15	1.65	.76	1.16	1.92	4.72		
1	.0054	4	21.3	0	0							35	1.75	2.8	.82	1.19	0	0	0	0		
.0		8	41.6	3.5	18.2	1	.05	4	.2			25	1.25	4.0	1.0	1.45	.91	.78	1.69	2.5		
1/2	.0014	4	31.2	4.0	10.4	9	.45	29	1.45			30	1.5	5.6	1.16	1.65	1.1	.94	2.04	2.28		
1/8	.8 x 10 ⁻⁴	4	41.6	5.5	28.6	1	.05	∞	∞			30	1.50	4.1	1.0	1.45	.83	.31	1.14	3.0		
		6																				
		8																				
		4																				
		6																				
		8																				



KINETICS INTERNATIONAL CORP.
845 Holly Drive S., Annapolis, Maryland 21401

Series = B

K = 3

D in	A _D ft ²	P ₂		P ₁		P ₀ in H ₂ O	P ₀ psf	Z _c mm	Z _c sec	Z ₀ mm	Z ₀ sec	Z _f in. H ₂ O	Z _f sec	m ₁₂ H ₂ O	m ₁₂ cfs	m ₁₀ cfs	m ₁₀ cfs	m ₁₀ cfs	m ₁₀ cfs	Pr	
		in H ₂ O	psf	in H ₂ O	psf																
1	2	3	4	5	6	7	8	9	10	11	12	13	14	15	16	17	18				
2	.022	4	20.8	1	5.2	20	1.0	2	.1	2	1.0	2.8	.82	1.17	.59	.89	1.46			4.0	
		6.1	31.7	1.2	6.24	10	.5	3	.15	3	1.0	4.1	1.0	1.45	.64	.97	1.61			5.0	
		8.1	42.1	1.7	8.84	4	.2	4	.2	4	1.25	5.6	1.16	1.67	.76	1.16	1.92			4.76	
1 1/2	.012	4.1	21.3	1.7	8.84	15	.75	7	.35	7	1.0	2.8	.82	1.19	.76	.65	1.41			2.40	
		6.1	31.7	2.4	12.50	7	.35	9	.45	9	1.0	4.1	1.0	1.45	.91	.86	1.77			2.54	
		8	41.6	3.5	18.2	1	.05	12	.6	12	1.0	5.5	1.15	1.65	1.1	.94	2.04			2.28	
1.0	.0034	4.1	21.3	1.9	9.9	11	.55	∞	∞	∞	1.85	2.8	.82	1.19	.81	.30	1.11			2.15	
0		6.1	31.7	4.0	20.8	15	.25	∞	∞	∞	1.25	4.1	1.0	1.45	1.17	.45	1.62			1.57	
1/2	.0014	4																			
		6																			
		8																			
1/4	3.4 x 10 ⁻⁴	4																			
		6																			
		8																			
1/8	.8 x 10 ⁻⁴	4																			
		6																			
		8																			



KINETICS INTERNATIONAL CORP.

845 Holly Drive S., Annapolis, Maryland 21401

$K = 1$

Series = C

D	in	Ad	ft ²	P _u	in H ₂ O	P _u	psf	P _o	in H ₂ O	P _o	psf	t _c	mm	t _c	sec	z _o	mm	z _o	sec	z _f	in	z _f	sec	t _f	mi ₂	H ₂ O	cfs	mi ₂	cfs	mi ₂	cfs	mi ₂	cfs	mi ₂	cfs	mi ₂	cfs	mi ₂	cfs	mi ₂	cfs																																																																																																																																																																																																																																																																																																																																																																																																																																																																																																																																																																																																																																																																																																																																																																																																																																																																																																																																																																																																		
																																										1	2	3	4	5	6	7	8	9	10	11	12	13	14	15	16	17	18																																																																																																																																																																																																																																																																																																																																																																																																																																																																																																																																																																																																																																																																																																																																																																																																																																																																																																																																																																																
2c		.022	4.2	21.8	0	0	0	5	6	7	8	9	10	11	12	13	14	15	16	17	18	19	20	21	22	23	24	25	26	27	28	29	30	31	32	33	34	35	36	37	38	39	40	41	42	43	44	45	46	47	48	49	50	51	52	53	54	55	56	57	58	59	60	61	62	63	64	65	66	67	68	69	70	71	72	73	74	75	76	77	78	79	80	81	82	83	84	85	86	87	88	89	90	91	92	93	94	95	96	97	98	99	100	101	102	103	104	105	106	107	108	109	110	111	112	113	114	115	116	117	118	119	120	121	122	123	124	125	126	127	128	129	130	131	132	133	134	135	136	137	138	139	140	141	142	143	144	145	146	147	148	149	150	151	152	153	154	155	156	157	158	159	160	161	162	163	164	165	166	167	168	169	170	171	172	173	174	175	176	177	178	179	180	181	182	183	184	185	186	187	188	189	190	191	192	193	194	195	196	197	198	199	200	201	202	203	204	205	206	207	208	209	210	211	212	213	214	215	216	217	218	219	220	221	222	223	224	225	226	227	228	229	230	231	232	233	234	235	236	237	238	239	240	241	242	243	244	245	246	247	248	249	250	251	252	253	254	255	256	257	258	259	260	261	262	263	264	265	266	267	268	269	270	271	272	273	274	275	276	277	278	279	280	281	282	283	284	285	286	287	288	289	290	291	292	293	294	295	296	297	298	299	300	301	302	303	304	305	306	307	308	309	310	311	312	313	314	315	316	317	318	319	320	321	322	323	324	325	326	327	328	329	330	331	332	333	334	335	336	337	338	339	340	341	342	343	344	345	346	347	348	349	350	351	352	353	354	355	356	357	358	359	360	361	362	363	364	365	366	367	368	369	370	371	372	373	374	375	376	377	378	379	380	381	382	383	384	385	386	387	388	389	390	391	392	393	394	395	396	397	398	399	400	401	402	403	404	405	406	407	408	409	410	411	412	413	414	415	416	417	418	419	420	421	422	423	424	425	426	427	428	429	430	431	432	433	434	435	436	437	438	439	440	441	442	443	444	445	446	447	448	449	450	451	452	453	454	455	456	457	458	459	460	461	462	463	464	465	466	467	468	469	470	471	472	473	474	475	476	477	478	479	480	481	482	483	484	485	486	487	488	489	490	491	492	493	494	495	496	497	498	499	500	501	502	503	504	505	506	507	508	509	510	511	512	513	514	515	516	517	518	519	520	521	522	523	524	525	526	527	528	529	530	531	532	533	534	535	536	537	538	539	540	541	542	543	544	545	546	547	548	549	550	551	552	553	554	555	556	557	558	559	560	561	562	563	564	565	566	567	568	569	570	571	572	573	574	575	576	577	578	579	580	581	582	583	584	585	586	587	588	589	590	591	592	593	594	595	596	597	598	599	600	601	602	603	604	605	606	607	608	609	610	611	612	613	614	615	616	617	618	619	620	621	622	623	624	625	626	627	628	629	630	631	632	633	634	635	636	637	638	639	640	641	642	643	644	645	646	647	648	649	650	651	652	653	654	655	656	657	658	659	660	661	662	663	664	665	666	667	668	669	670	671	672	673	674	675	676	677	678	679	680	681	682	683	684	685	686	687	688	689	690	691	692	693	694	695	696	697	698	699	700	701	702	703	704	705	706	707	708	709	710	711	712	713	714	715	716	717	718	719	720	721	722	723	724	725	726	727	728	729	730	731	732	733	734	735	736	737	738	739	740	741	742	743	744	745	746	747	748	749	750	751	752	753	754	755	756	757	758	759	760	761	762	763	764	765	766	767	768	769	770	771	772	773	774	775	776	777	778	779	780	781	782	783	784	785	786	787	788	789	790	791	792	793	794	795	796	797	798	799	800	801	802	803	804	805	806	807	808	809	810	811	812	813	814	815	816	817	818	819	820	821	822	823	824	825	826	827	828	829	830	831	832	833	834	835	836	837	838	839	840	841	842	843	844	845	846	847	848	849	850	851	852	853	854	855	856	857	858	859	860	861	862	863	864	865	866	867	868	869	870	871	872	873	874	875	876	877	878	879	880	881	882	883	884	885	886	887	888	889	890	891	892	893	894	895	896	897	898	899	900	901	902	903	904	905	906	907	908	909	910	911	912	913	914	915	916	917	918	919	920	921	922	923	924	925	926	927	928	929	930	931	932	933	934	935	936	937	938	939	940	941	942	943	944	945	946	947	948	949	950	951	952	953	954	955	956	957	958	959	960	961	962	963	964	965	966	967	968	969	970	971	972	973	974	975	976	977	978	979	980	981	982	983	984	985	986	987	988	989	990	991	992	993	994	995	996	997	998	999	1000



KINETICS INTERNATIONAL CORP.

845 Holly Drive S., Annapolis, Maryland 21401

$K=2$

Series C

D in	Ad ft ²	P _u in H ₂ O	P _u psf	P _o in H ₂ O	P _o psf	t _c mm	t _c sec	t ₀ mm	t ₀ sec	Z _f in	Z _f sec	m _{ic} H ₂ O	mic		max		min		P _f	
													cfs	cfm	cfs	cfm	cfs	cfm		cfs
1	2	3	4	5	6	7	8	9	10	11	12	13	14	15	16	17	18			
2c	.022	4.1	21.3	0	0					2.5	1.25	2.7	.81	1.19	0	0	0			
c		6	31.2	0	0					2.0	1.0	4.1	1.0	1.45	0	0	0			
c		8	41.6	0	0					2.5	1.25	5.5	1.15	1.65	0	0	0			
1/2c	.012	4	20.8	0	0					2.0	1.0	2.9	.84	1.17	0	0	0			
c		6	31.2	0	0					2.0	1.0	4.1	1.0	1.45	0	0	0			
0		8.2	42.6	0	0	1	.05					5.6	1.16	1.65	0	0	0			
1	.0054	4	20.8	0	0					2.0	1.0	2.8	.82	1.17	0	0	0			
		6	31.2	4.2	21.8	5.27	26.35	36	1.8	2.0	1.0	4.1	1.0	1.45	1.20	.46	1.66		1.43	
		8.2	42.6	8.6	29.1	1.72	8.6	111	5.55	3.5	1.75	5.6	1.16	1.65	1.39	.53	1.92		1.46	
1/2c	.0014	4	20.8	0	0	1	.05			1.5	.75	2.7	.81	1.17	0	0	0			
0		6.2	32.2	6.2	32.2	5.57	17.85			1.0	.50	4.1	1.0	1.46	1.46	.14	1.60		1.0	
1/4	3.4 x 10 ⁻⁴	4																		
		6																		
		8																		
1/8	.8 x 10 ⁻⁴	4																		
		6																		
		8																		

KINETICS INTERNATIONAL CORP.

845 Holly Drive S., Annapolis, Maryland 21401

$K = 3$

Series = C

D in	As ft ²	P ₄ in H ₂ O	P ₄ psf	P ₅ in H ₂ O	P ₅ psf	t _c mm	t _c sec	z ₀ mm	z ₀ sec	z _f in	z _f sec	t _f sec	m ₁₀		m ₁₅		m ₂₀		P _f
													cfs	ft ³ /sec	cfs	ft ³ /sec	cfs	ft ³ /sec	
2	.022	3	21.3	.9	4.7	501	25.05	13	.65	20	1.0	1.0	13	14	15	16	17	18	4.53
		6	31.2	1.2	6.24	301	15.05	15	.75	12	.6	4.1	1.0	1.0	1.43	.61	.97	1.58	5.0
		8.2	42.6	1.7	8.84	140	7.0	17.5	.88	40	2.0	5.5	1.15	1.69	.76	1.16	1.91	4.8	
1/2	.012	4	20.8	1.4	7.28	415	20.9	24	1.2	22	1.1	2.8	.82	1.17	.69	.6	1.29	2.85	
		6	31.2	1.7	8.84	164	8.2	34	1.7	20	1.0	4.1	1.0	1.43	.76	.65	1.41	3.53	
		8.2	42.6	3.3	17.2	91	4.55	39	1.95	35	1.75	5.5	1.15	1.68	1.07	.91	1.98	2.48	
0	.0054	4	20.8	0	0	369	18.45	∞	∞	20	1.0	2.6	.79	1.17	0	0	0	0	
0		6	31.2	4	20.8	123	6.15	∞	∞	25	1.25	4.1	1.0	1.43	1.17	.95	1.62	1.5	
0		8	42.6	5.5	28.6	47	2.35	∞	∞	25	1.25	5.6	1.16	1.65	1.37	.52	1.90	1.45	
1/2	.0014	4																	
		6																	
		8																	
1/4	3.4 x 10 ⁻⁴	4																	
		6																	
		8																	
1/8	.8 x 10 ⁻⁴	4																	
		6																	
		8																	

7. APPARATUS & INSTRUMENTATION INFORMATION

1. Instrumentation

(i) Pressure Transducers

- Upper Plenum

Gould-Statham Mod VC2
fitted with 0-1 psi diaphragm

- Lower Plenum

Gould-Statham Mod VC2
fitted with 0-2 psi diaphragm

- Transducer Power Supply

HP Mod 6205B

(ii) Strip Chart Recorder

- Gould/Brush Mod 280
2 Channel plus event marker

(iii) Air Supply Fan

- Clements Manufacturing Co.

Mod HVU

(iv) Damper

- Airpot Corp.

Variable damping coefficient
Airpot, Mod 49863-1

(v) Fan Output Controller

- Cole/Parmer Instrument Co.

Variac, Mod 2603

(vi) Dump Valve Solenoid

- Lehigh Fluid Power Co.

Mod 549A3S

2. Apparatus Parameters

(i) Air Supply Flow Meter

- 1.750 diameter ASME orifice plate

- Flow area = .017 ft²

- Discharge coefficient = 0.66

(ii) Tension Springs

- Series 1 K = 1.0 lb/in.

- Series 2 K = 0.5 lb/in.

- Series 3 K = 0.18316/in.

(iii) Damping Coefficients

- Series A C_f = 0.030 lb-sec/in.

- Series B C_f = 0.1356 lb-sec/in.

- Series C C_f = 2.148 lb-sec/in.

(iv) Valve Weights (PMV)

- Valve Disk = 130 gms

- Valve Stem = 11 gms

- Damper piston = 13 gms

Total moving weight = .339#_f

(v) Valve flow areas (PMV)

- Central 5" diameter opening = .136 ft²

- Valve parameter area = $\pi D_v h = (\pi \times 8 \times .75) / 144$
= .130 ft²

(vi) Dump Valve Flow Area

- $(2" \times 13.5" \times 12)/144 = 2.25 \text{ ft}^2$

(vii) Valve Stroke (PMV)

- Distance between up (open) and full down (closed) positions is .75"

(viii) Bypass Orifice Diameters/Areas

- 2" diameter = $.022 \text{ ft}^2$

- 1 1/2" " = .012

- 1" " = .0054

- 1/2" " = .0014

- 1/4" " = .00034

- 1/8" " = .00008

(ix) Plenum Volumes

- Upper Plenum = 12.04 ft^3

- Lower Plenum = 8.36 ft^3

(x) Nominal Upper Plenum Pressures

- 4" H₂O

- 6" H₂O

- 8" H₂O

(xi) Upper Plenum Relief Outlet

- Flow area $.010 \text{ ft}^2$

- Discharge coefficient = .89

ATE
LMED

Series =

D	A_D	P_n	T
m	ft ²	in ⁴	r
1	2	3	2
2	.022	4.3	2
		6.4	3
		8	4
1/2	.012	4.1	2
		6.3	3
		8.3	4
1-0	.0057	4.3	2
		6	3
		8	4
1/2	.0014	4	2
		6	3
		8	4
1/4	3.4 $\times 10^{-4}$	4	2
		6	3
		8	4
1/8	.8 $\times 10^{-4}$	4	2
		6	3
		8	4

Series

D	fL^2	P_2
1	2	3
2	.022	4.3 6.2 8.3
1 1/2	.012	4.2 6 8.3
1	.0034	4.2 6 8
1/2	.0014	4 6 8
1/4	3.4 $\times 10^{-4}$	4 6 8
1/8	.8 $\times 10^{-4}$	4 6 8

Series

D	A _b	P ₂
in	ft ²	in ⁴
1	2	3
2c	.022	4.1
c		6.1
c		8.3
1/2c	.012	4.1
c		6
		8.3
1-c	.0034	4.1
c		6.1
		8
1/2-c	.0014	4.1
D		6.1
		8
1/4	3.4	4
	x10 ⁻⁴	6
		8
1/8	.8	4
	x10 ⁻⁴	6
		8

Series =

D	Ab	P _n	F
in	ft ²	in ²	ft ²
1	2	3	
2-C	.022	4.1	2
-C		6.1	3
		8	4
1 1/2-C	.012	4.1	2
		6.0	3
		8	4
1	.0037	4	2
.0		6	3
		8	4
1/2	.0014	4	2
		6	3
		8	4
1/4	3.4 x 10 ⁻⁴	4	2
		6	3
		8	4
1/8	.8 x 10 ⁻⁴	4	2
		6	3
		8	4

Series = 3

D	A_D	P_L	P
in	ft ²	in ⁴⁰	ft
1	2	3	4
2	.022	4	20.
		6.1	31.
		8.1	42.
1 1/2	.012	4.1	21.
		6.1	31.
		8	41.
1.0	.0054	4.1	21.
0		6.1	31.
		8	
1/2	.0014	4	
		6	
		8	
1/4	3.4	4	
	$\times 10^4$	6	
		8	
1/8	.8	4	
	$\times 10^4$	6	
		8	

Series = C

D	Ab	P _n	F
in	ft ²	in ⁴	in
1	2	3	4
2c	.022	4.2	21
c		6	31
c		8.3	41
1 1/2c	.012	4	20
c		6.3	32
c		8	41
1c	.0054	4	20
c		6	31
c		8	41
1/2c	.0014	4	20
c		6.3	32
c		8.3	43
1/4c	3.4	4	20
c	x10 ⁻⁴	6	31
c		8	4
1/8c	.8	4	20
c	x10 ⁻⁴	6	31
c		8	4