

AD-A139 159

MASTER PLAN TUCSON DIVERSION CHANNEL RECREATION
DEVELOPMENT PROGRAM GILA RIVER AND TRIBUTARIES ARIZONA
AND NEW MEXICO(U) ARMY ENGINEER DISTRICT LOS ANGELES CA

1/2

UNCLASSIFIED

OCT 81

F/G 13/2

NL



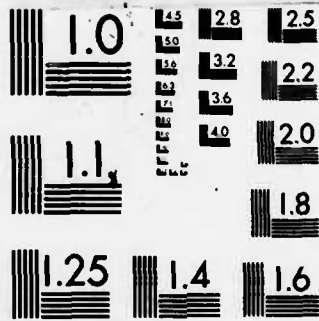

MICROCOPY RESOLUTION TEST CHART
NATIONAL BUREAU OF STANDARDS-1963-A

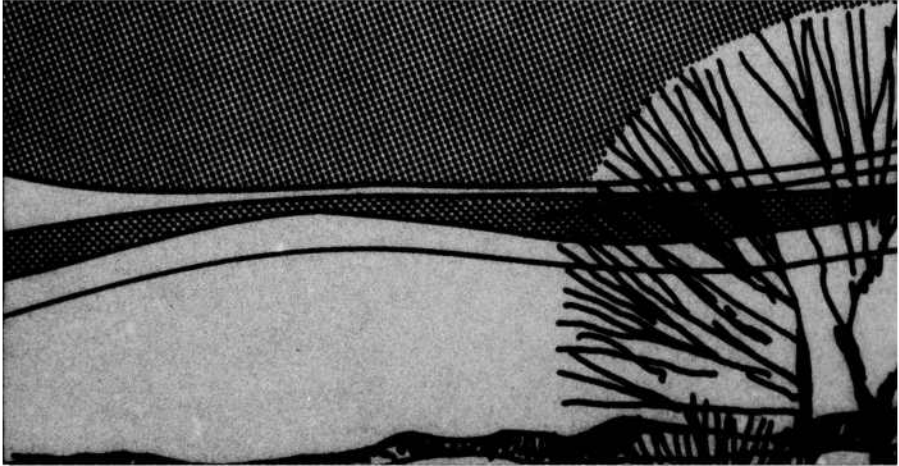

REPORT DOCUMENTATION PAGE		READ INSTRUCTIONS BEFORE COMPLETING FORM	
1. REPORT NUMBER	2. GOVT ACCESSION NO.	3. RECIPIENT'S CATALOG NUMBER	
	AD-A239259		
4. TITLE (and Subtitle) Tucson Diversion Channel Recreation Development Program (Master Plan)		5. TYPE OF REPORT & PERIOD COVERED	
		6. PERFORMING ORG. REPORT NUMBER	
7. AUTHOR(s)		8. CONTRACT OR GRANT NUMBER(s)	
		N/A	
9. PERFORMING ORGANIZATION NAME AND ADDRESS U.S. Army Corps of Engineers Los Angeles District P.O.Box 2711 Los Angeles, CA 90053		10. PROGRAM ELEMENT, PROJECT, TASK AREA & WORK UNIT NUMBERS	
		N/A	
11. CONTROLLING OFFICE NAME AND ADDRESS		12. REPORT DATE	
		October 1981	
		13. NUMBER OF PAGES	
14. MONITORING AGENCY NAME & ADDRESS (if different from Controlling Office)		15. SECURITY CLASS. (of this report)	
N/A		Unclassified	
		15a. DECLASSIFICATION/DOWNGRADING SCHEDULE	
16. DISTRIBUTION STATEMENT (of this Report) Approved for public release; distribution unlimited.			
17. DISTRIBUTION STATEMENT (of the abstract entered in Block 20, if different from Report)			
18. SUPPLEMENTARY NOTES Copies are obtainable from the National Technical Information SVCS Springfield, VA 22151			
19. KEY WORDS (Continue on reverse side if necessary and identify by block number) Recreation Planning Flood Control			
20. ABSTRACT (Continue on reverse side if necessary and identify by block number) Dryland recreation facilities, a multi-purpose lake, and needed support facilities will be developed in the Tucson Detention Basin. The Basin is a unit of the existing Tucson Diversion Channel Flood Control Project. The purpose of this plan are to (1) to propose a coordinated development plan for all project resources; and (2) to provide a basis for advancing to detailed design under the Code 710 program.			

MASTER PLAN
TUCSON DIVERSION CHANNEL

DTIC
ELECTE
S MAR 21 1984
A

SEPTEMBER 1981

This document has been approved
for public release and sale; its
distribution is unlimited.

PREFACE

Under this master plan, dryland recreation facilities, a multipurpose lake, and needed support facilities will be developed in the Tucson Detention Basin. The basin is a unit of the existing Tucson Diversion Channel Flood Control Project. The proposed facilities will be developed in phases of recreation development under the Code 710 Program, in cooperation with Pima County, Arizona, the local sponsor of the proposed project.

The purposes of this master plan are to (1) propose a coordinated development plan for all project resources; and (2) provide a basis for advancing to detailed design under the Code 710 program. On plan approval, a detailed feature design memorandum (FDM) will be prepared.



Accession For	
NTIS GRA&I	<input checked="" type="checkbox"/>
DTIC TAB	<input type="checkbox"/>
Unannounced	<input type="checkbox"/>
Justification	
By	
Distribution/	
Availability Codes	
Dist	Avail and/or Special
A-1	

PREVIOUSLY ISSUED REPORTS

Review Report on Interim Survey for Flood Control. Tucson, Arizona, and Vicinity, Gila River Basin, Arizona and New Mexico. U.S. Army Corps of Engineers, Col. C.T. Newton, District Engineer; 26 January 1959.

Design Memorandum No. 1, General Design for Tucson Diversion Channel, Tucson, Arizona. Prepared by U.S. Army Engineer District, Los Angeles Corps of Engineers; November 1962.

CONTENTS

PREFACE	iii
PREVIOUSLY ISSUED REPORTS	iv
GLOSSARY	ix
I. INTRODUCTION	1
A. PROJECT AUTHORIZATION	1
B. PROJECT PURPOSE	1
C. PURPOSE OF THE MASTER PLAN	2
D. SCOPE OF THE MASTER PLAN	2
E. HISTORY OF THE PROJECT	2
F. FINAL ENVIRONMENTAL ASSESSMENT	3
G. PERTINENT REGULATIONS AND PUBLICATIONS	3
1. Regulations	3
2. Publications	4
3. Application of Public Laws	4
H. PROJECT DESCRIPTION	5
1. Location	5
2. Project Features	5
3. Basin Hydraulics	7
4. Basin Operation	7
5. Operation and Maintenance	7
II. RESOURCE BASE	9
A. ENVIRONMENTAL AND CULTURAL RESOURCES	9
1. Climate	9
2. Physiography	10
3. Hydrology	10
4. Groundwater	10
5. Reclaimed Water Supply	11
6. Soils	11
7. Archeology	11
8. Vegetation	12
9. Wildlife	13
10. Visual and Spatial Quality	13
B. SOCIAL AND ECONOMIC FACTORS	17
1. Population Characteristics	17
2. Education and Income	17
3. Existing Land Use and Patterns of Growth	17
4. Economic Factors	18
5. Recreation Trends	18
6. Recreation Demand	18
7. Competing Regional Parks	19
8. Potential Visitation	20
C. RESOURCE BASE SUMMARY - OPPORTUNITIES AND CONSTRAINTS	20
D. RESOURCE USE OBJECTIVES	21
1. Basic Objectives	21
2. Resource Use Goals	21
3. Objectives Related to Land Use Allocation	22

CONTENTS (CONTINUED)

III.	THE PLAN	25
A.	EXISTING RECREATION USE OF TUCSON DETENTION BASIN	25
B.	PROPOSED RECREATION DEVELOPMENT	25
	1. Low-Flow Channel	25
	2. Dryland Recreation	25
C.	STORM WATER	26
D.	COST-SHAREABILITY OF PROJECT FEATURES	26
	1. Land Acquisition	26
	2. Access, Parking, Restrooms and Upper Picnic Areas	26
	3. Other Project Features	26
	4. Project Operation and Maintenance	26
E.	PLANNING/DESIGN CRITERIA	26
F.	PROPOSED DEVELOPMENT SCHEDULE	27
G.	FACILITY DEVELOPMENT	27
	1. Phase I	27
	2. Future Development	30
IV.	SPECIAL PROBLEMS	33
A.	CONSTRUCTION COSTS ASSOCIATED WITH FUTURE LAKE RECREATION DEVELOPMENT	33
B.	ALTERNATIVE DESIGN OPTIONS FOR FUTURE RECREATION DEVELOPMENT	33
V.	AGENCY COORDINATION AND PUBLIC INVOLVEMENT	35
VI.	COST AND RECREATION BENEFIT ESTIMATES	37
A.	COST ESTIMATES	37
B.	RECREATION BENEFITS	40
	1. Benefit-Cost Analysis	40
	2. Development of User-Day Values	40
	3. Phase I	41
	4. Future Development	43
VII.	COST-SHARING UNDER THE CODE 710 PROGRAM	45
VIII.	OPERATION, MAINTENANCE AND MANAGEMENT	47
A.	GENERAL	47
B.	MANAGEMENT OBJECTIVES	47
C.	OPERATIONAL CONCEPTS AND POLICIES	48
D.	ADMINISTRATION	48
E.	STAFFING AND ORGANIZATION	48
F.	LAW ENFORCEMENT	48
G.	SAFETY	48
IX	CONCLUSIONS AND RECOMMENDATIONS	49
A.	CONCLUSIONS	49
B.	RECOMMENDATIONS	49

CONTENTS (CONTINUED)

APPENDIXES

A.	PERTINENT CORRESPONDENCE	A-1
B.	ENVIRONMENTAL ASSESSMENT OF RECREATION DEVELOPMENT AT THE TUCSON DETENTION BASIN	B-1
	A. DESCRIPTION OF PROPOSED PROJECT	B-1
	B. DESCRIPTION OF EXISTING ENVIRONMENT	B-1
	C. ENVIRONMENTAL IMPACTS	B-2
	D. CONCLUSION	B-3
C.	SOILS REPORT	C-1
D.	WATER QUALITY STANDARDS FOR RECREATION	D-1
	A. WATER QUALITY STANDARDS FOR RECREATION	D-1

TABLES

1.	Estimated Cost of Phase I Recreation Development	38
2.	User Day Values	41
3.	Phase I Benefits and Costs	42
4.	Phase I Cost-Shareable Features	45

PHOTOS

1.	Looking East Toward the Inlet Channel of the Tucson Detention Basin	8
2.	Looking Southwest at the Outlet Channel of the Tucson Detention Basin	8
3.	Piles of Sand and Gravel Debris	10
4.	Typical Vegetation in the Tucson Detention Basin	12
5.	Grasses and Shrubs on Levee Walls Where Moisture is Scarce	13
6.	Palo Verde Trees on the Northwest Levee	14
7.	On the North Levee, Looking Northwest to the Residential Area	15
8.	Looking Across the Detention Basin to the Industrial Area on County Club Road	15
9.	Canopy of Tall Mesquite Trees Enhances the Basin	16

CONTENTS (CONCLUDED)

FIGURES

1.	Project Location	6
2.	Air Temperatures for the Tucson Metropolitan Area	9

PLATES

1.	Site Analysis	51
2.	Existing Parks	53
3.	Recommended Plan for Recreation Phase I	55
4.	Recommended Plan for Future Recreation	57

GLOSSARY

AORCC	Arizona Outdoor Recreation Coordinating Commission
ASTM	American Society for Testing Materials
BOD	Biological oxygen demand
CBEA	Cella, Barr, Evans and Associates
CBR	Cost-benefit ratio
EIS	Environmental impact statement
EPA	Environmental Protection Agency
ER	Engineering Regulation
FDM	Feature Design Memorandum
ft ²	Square foot
ft ³ /s	Cubic feet per second
LADM	Los Angeles District Manual
LS	Lump sum
mg/BOD	Million-gallon biological oxygen demand
mgd	Million gallons per day
mg/l	Milligrams per litre
NED	National Economic Development
NS	No standard
Par course	A system of exercise stations used for recreation
PVC	Polyvinyl chloride
SCORP	Statewide Comprehensive Outdoor Recreation Plan
SPF	Standard project flood
SS	Suspended solids
TDS	Total dissolved solids
USGS	U.S. Geological Survey
yd ²	Square yard

I. INTRODUCTION

The project's authorization, purpose, history, and other aspects are described in this section.

A. PROJECT AUTHORIZATION

The Tucson Diversion Channel project was authorized by Public Law 80-858, approved 30 June 1948. Pursuant to a resolution of the Committee on Public Works of the United States Senate, dated 17 March 1955, the plan was modified, as detailed in a review report dated 26 January 1959. Construction of the flood control project was initiated on 16 April 1963 and completed on 12 April 1966. The project was transferred to the Board of Supervisors of Pima County, Arizona, for operation and maintenance on 11 August 1966.

The Flood Control Act of 1944 (Public Law 78-534), as amended, authorizes the Corps to construct, maintain, and operate public park and recreation facilities at water resource development projects. The law also permits the Corps of Engineers to authorize local interests to construct, maintain, and operate recreation facilities. Under the Code 710 program, as outlined in EC 11-2-127, dated 15 April 1977, Federal funding is available for recreation facilities at completed Corps projects, provided local agencies furnish 50 percent of the development costs.

The proposed recreation development project will be built on county-owned lands originally acquired for flood control. Approximately 20 acres, acquired by Pima County, will be needed for access, parking, and operation of the facility. A cost-sharing agreement will be established whereby, before construction, Pima County will pay 50 percent of the cost-shareable recreation development expenses and 100 percent of the non-cost-shareable development expenses. The county will also assume all operation and maintenance responsibilities on project completion.

B. PROJECT PURPOSE

Flood control will remain the primary purpose of the detention basin. This report will demonstrate that the proposed dryland and water-based recreation facilities can be incorporated without sacrificing the basin's efficiency or design capacity.

The planning analysis was confined to the project limits of the detention basin because Pima County's primary concern was the possibility of creating a water-based recreation facility.

The need for additional land- and water-based recreation facilities in the Tucson and Eastern Pima County regions was established in the State-wide Comprehensive Outdoor Recreation Plan (SCORP) prepared by the Arizona Outdoor Recreation Coordinating Commission (AORCC). Therefore, the proposed multiple-purpose facility will generate recreation benefits in addition to the present flood control benefits.

C. PURPOSE OF THE MASTER PLAN

The master plan for the Tucson Detention Basin will serve as a guide to insure optimum development of the basin's natural and recreation resources. This plan is based on an inventory and analysis of the opportunities and constraints for recreation development. The physical plan for recreation development, the proposed phasing, and the associated costs and benefits for the project will be presented.

D. SCOPE OF THE MASTER PLAN

The master plan will provide a general overview of the existing flood control features. It will present a concise analysis of both local and regional recreation demands and of existing and future land uses. Also, it will describe the basin's natural resources - how they will be used and impacted by the proposed development, and how the proposed recreation facilities will be incorporated into the existing flood control structure.

Critical issues raised by the local population will be discussed. A series of public meetings held in 1977 brought out relevant areas of concern, such as groundwater use, wildlife habitat destruction, and the noise levels that may be generated by the project. These issues will be considered in the body of the report.

Finally, the report will present the costs and schedule for project development and the specific responsibilities of the Corps and the local project sponsor, Pima County.

E. HISTORY OF THE PROJECT

In the early 1970s, the Pima County Board of Supervisors expressed substantial interest in developing water-based recreation facilities in the Tucson Detention Basin. The Board appointed a Citizens Committee Bond Advisory Council, which recommended a bond election. A special election was held in February 1974, with 62 percent of those voting in favor of the bond issue.

On 3 March 1975, Pima County retained the professional engineering services of Cella, Barr, Evans and Associates (CBEA) to determine the feasibility of planning, constructing, maintaining, and operating a lake and associated park facilities. If the project were to prove feasible, CBEA was to prepare a preliminary design and management plan. In January 1976, CBEA published its initial findings, having determined that it was feasible to design and construct a multiple-purpose lake and facilities in the detention basin. CBEA referred to the proposed recreation area as the "Ajo Way Detention Basin Wet Park."

In April 1976, the Corps of Engineers was invited to participate through the Code 710 program. In June 1976, the Los Angeles District Office received a letter of intent submitted by the Pima County Board of Supervisors, requesting Corps participation in a joint effort to develop recreation facilities in the basin. On 5 May 1977, the Corps met with representatives of Pima County, and the research leading to the Letter Report of May 1978 was initiated.

In September 1977, with the recommendation of the Pima County Parks and Recreation Department, the mayor and the City Council of Tucson agreed by unanimous vote to divert water from the secondary treatment plant at Randolph Park to the Tucson Detention Basin for tertiary treatment and ultimate use in the proposed lake.

In April 1978 it became evident that the local sponsors had problems with funding for the lake recreation development, because of the increase in construction costs since the 1976 CBEA Report was published. Alternative funding proposals were formulated.

In May 1978 the letter report with alternative funding proposals and phasing of development was submitted to the Corps division office for review. In September 1978 comments were received from the division office. These included a statement that a treatment plant, as outlined in the letter report, was not a cost-shareable item. This decision placed additional financial burdens on the local sponsor.

Cost-feasible alternative tertiary treatment methods also were investigated. In March 1979 Rod Gomez and Associates were commissioned to investigate the lake water supply in more detail. The report, completed in November 1979, uncovered problems with the plant's operating capacity and determined the water quality of the effluent. Higher cost estimates were quoted for the tertiary treatment part of the proposed project.

Alternative phasing of the recreation development was proposed, with the dryland facilities to be built in the first phase. This alternative was presented to the Pima County Parks Commission in December 1979 and was approved by the Board of Supervisors in January 1980. (See the Letter of Approval, appendix A.)

F. FINAL ENVIRONMENTAL ASSESSMENT

The Los Angeles District has prepared a final environmental assessment on the proposed project. This assessment can be found in appendix B.

G. PERTINENT REGULATIONS AND PUBLICATIONS

The following regulations and publications were used in the preparation of this master plan.

1. Regulations

- a. EC11-2-127 - Code 710 Program, Recreation Development at Completed Projects, 15 April 1977.
- b. ER1110-2-400 - Design of Recreation Sites, Areas, and Facilities, 7 July 1972.
- c. ER1120-2-400 - Investigations, Planning and Development of Water Resources, Recreation Resources Planning, 1 November 1977.

2. Publications

- a. **Review Report on Interim Survey for Flood Control, Tucson, Arizona, and Vicinity, Gila River Basin, Arizona and New Mexico. U.S. Army Corps of Engineers. Col. C.T. Newton, District Engineer, January 26, 1959.**
- b. **Design Memorandum No. 1, General Design Memorandum for Tucson Diversion Channel, Tucson, Arizona. November 1962.**
- c. **Ajo Way Detention Basin Wet Park Feasibility Design Study, Initial Design. Cella, Barr, Evans and Associates, Tucson, Arizona. January 1976. Final Report.**
- d. **Parks, Recreation and Open Space: A Conceptual Plan for Tucson-Pima County, June 1978. Briscoe, Maphis, Murray and Lamont, Inc., Key/Fletemeyer Associates, Boulder, Colorado.**
- e. **Feasibility Study: Proposed Wet Park at the Tucson Detention Basin, Pima County, Arizona. RGA Consulting Engineers, November, 1979.**

3. **Application of Public Laws – The following Federal laws provide for the development and management of Federal projects for various purposes, according to the intent of Congress.**

- a. **Public Law 534-78 16 U.S.C. 460 d., as amended by the Flood Control Acts of 1946, 1954, 1960, and 1962, authorizes the Corps of Engineers to construct, maintain, and operate public park and recreation facilities at water resource development projects and to permit local interests to construct, maintain, and operate such facilities.**
- b. **Public Law 89-72 16 U.S.C. 460 1-12 through 460 1-21, accompanied by House Committee Report No. 254, requires cost-sharing of recreation between the Federal Government and local interests. Under this policy and the memorandum dated 12 June 1976, from Victor V. Veysey, Assistant Secretary of the Army (Civil Works), local interests must meet the following requirements:**
 - **Acquire in the county's name, and dedicate to public outdoor recreation use for the economic life of the basic flood control improvements, all lands needed for recreation development and assurance of public control of the development. Recreation developments will be provided within the lands acquired by local interests for the basic flood control project only, except as may be required for access, parking, potable water, sanitation, and related developments for health, safety, and public access. Credit is given for lands, as indicated below.**

- Where the appraised value of the land, as described above, amounts to less than 50 percent of the total first cost of the recreation development, make additional contributions sufficient to bring the non-Federal share to at least that level; additional contributions may consist of the actual cost of carrying out an agreed on portion of the development, or a cash contribution, or a combination of both.
- Operate, maintain, and replace, without expense to the Federal Government, the recreation areas and all facilities installed, pursuant to the agreement.
- Share in the cost of mitigation of damages caused by recreation development, as these are joint costs and will be allocated to the responsible parties of the project in the same way as other joint costs.

Local responsibilities with regard to the cost-sharing agreement will be addressed in the Operation and Management section of the Master Plan.

- c. Public Law 91-190 42 U.S.C. 4231 etc. requires that an environment assessment be prepared for every Federal project. A final environmental assessment on the proposed project has been prepared and can be found in appendix B. The final environmental assessment determined that there is no need to prepare an environmental impact statement.
- d. The 1974 Water Resources Development Act (Public Law 93-251), as well as earlier and related legislation prescribes that water quality and water pollution control must be given full consideration in the planning and construction of federal water resources development projects.

H. PROJECT DESCRIPTION

1. Location

The existing flood control project, which was completed in 1966, is in southeast Tucson in Pima County, Arizona. The detention basin is north of Ajo Way and west of Country Club Road. (See figure 1.) The project protects developed areas in and around the city of Tucson, as well as residential property in the overflow area along Julian Wash, against flooding. It intercepts flows from the upstream part of the Tucson Arroyo and the Railroad Wash drainage areas, and diverts these flows around the southern edge of Tucson and into the Santa Cruz River.

2. Project Features

The project drains a 47.6-square mile area. The detention basin was constructed by building dikes about 20 feet high around an area of about 120 acres. The existing basin and spillway system

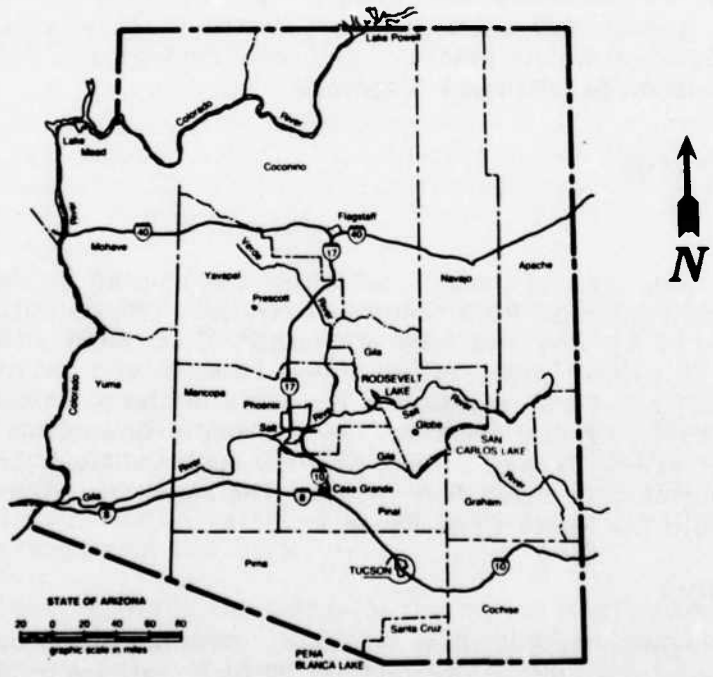
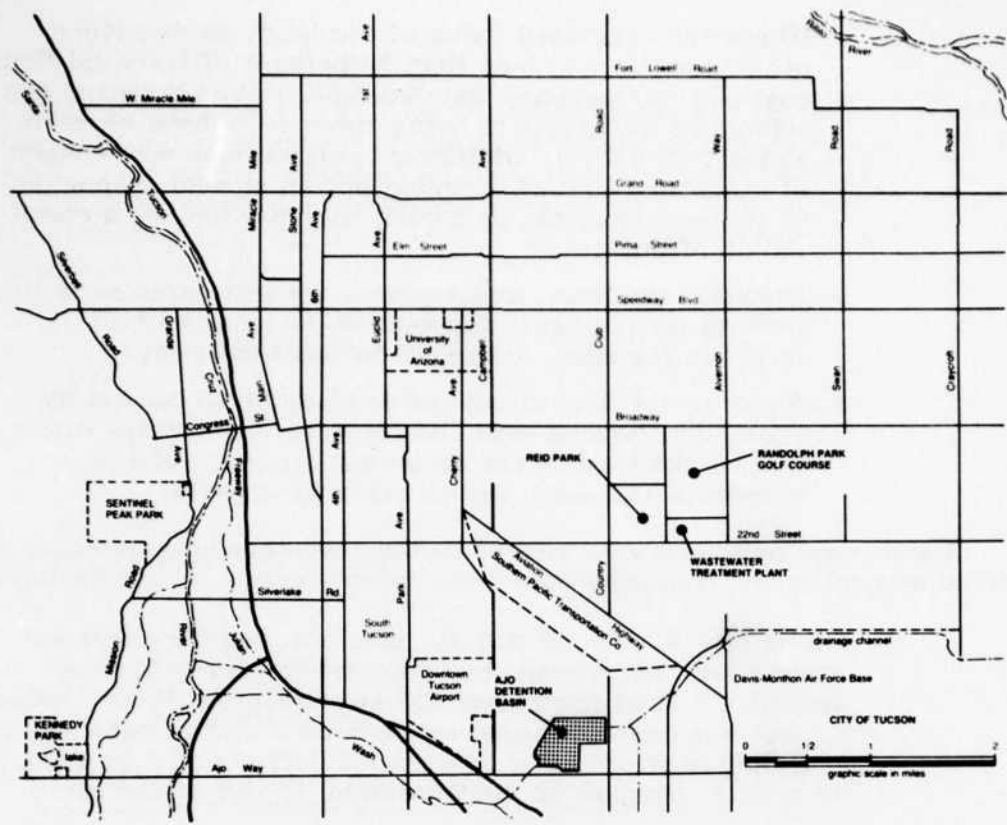

Figure 1. Project Location.

provides sufficient regulatory storage to reduce the standard project flood from an inflow peak of 15,300 cubic feet per second (ft^3/s) to an outflow peak of 9,300 ft^3/s . The total design storage capacity is 1800 acre-feet.

The project includes an interceptor levee, channel, detention basin, inlet channel, and outlet channel. (See photos 1 and 2.) Components constructed by the Federal Government include two railroad bridges side drainage inlet structures, access roads, invert-access ramps, and safety fencing. Other project components, constructed by local interests, include highway bridges at major crossings and relocation of public and private utilities.

3. Basin Hydraulics

The greatest floods in the drainage area result from thunderstorms of high intensity and short duration. During these thunderstorms which are common in summer, the duration of critical rainfall intensity varies between 2 and 3 hours. The greatest intensity usually occurs shortly after the beginning of the storm. The effect of snowmelt on floods in the Tucson metropolitan area is negligible.

4. Basin Operation

The basin is designed for a standard project flood (SPF) of 15,300 ft^3/s . Under existing conditions, the SPF depth relationship in the basin would be as follows.

<u>Elapsed Time (min)</u>	<u>Approximate Water Peak Discharge (ft^3/s)</u>	<u>Depth in Basin (ft)</u>
30	1,000	1
40	2,000	1
60	5,000	1
90	10,200	4
150	15,300	13

The existing basin can drain its capacity of water in one day. Construction of the proposed project would not alter the SPF inflow-depth relationship in the basin.

5. Operation and Maintenance

The Pima County Board of Supervisors operates and maintains the diversion channel project in accordance with LADM 1130-2-46, Operation and Maintenance Manual for Tucson Diversion Channel, Tucson, Arizona. This document makes it the responsibility of the Board to inspect, maintain, and operate the facility to insure serviceability of the structure in floods.



**Photo 1. Looking East Toward the Inlet Channel
of the Tucson Detention Basin.**



**Photo 2. Looking Southwest at the Outlet Channel
of the Tucson Detention Basin.**

II. RESOURCE BASE

The area's resources and their uses are described in this section.

A. ENVIRONMENTAL AND CULTURAL RESOURCES

Physical aspects of the basin are described below.

1. Climate

The climate of the project area is subtropical and semiarid. The winters are short and mild, and the summers are long and hot. For 64 years, the average monthly temperature recorded by the United States Weather Bureau Station at Tucson ranged from 49.6° for January to 86.8°F for July. (See figure 2.) Mean annual precipitation at Tucson is estimated at 10.5 inches. Winter and summer have the most precipitation. Spring and fall are relatively dry. The prevailing winds are from the southeast at 8.1 mph.

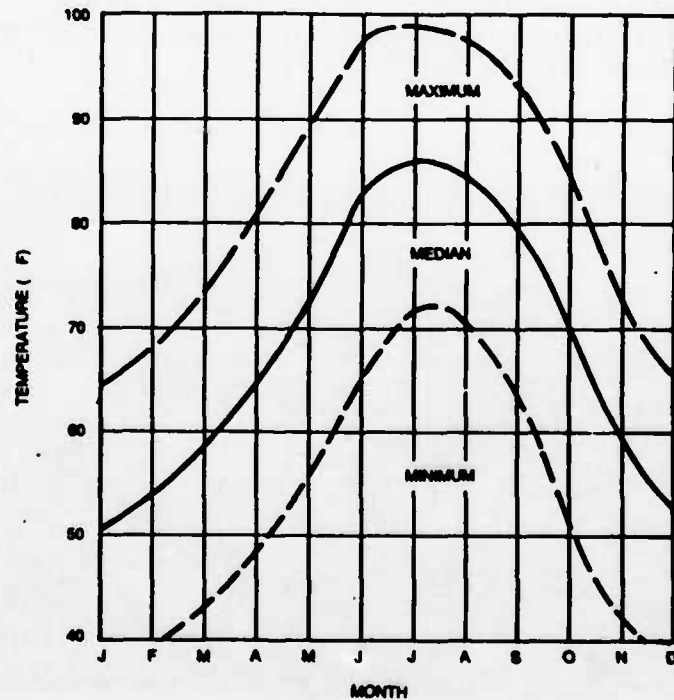

SOURCE: UNITED STATES WEATHER BUREAU RECORDS

Figure 2. Air Temperatures for the Tucson Metropolitan Area.

2. Physiography

The area of the manmade detention basin is approximately 120 acres. The basin is flat and contains a low-flow channel approximately 2450 feet long. (See photo 3.) Twenty-foot-high earth levees border the basin on three sides. Drainage patterns in the upper half of the basin have been disturbed by earlier sand and gravel operations. Large piles of earth and debris remain, now causing storm water to pond temporarily in the upper half of the basin.

3. Hydrology

(See Basin Hydraulics, discussed in Chapter 1, Project Description.)

4. Groundwater

Supplies of groundwater in the Tucson area are diminishing. Groundwater withdrawals for both irrigation and commercial-industrial uses have caused large groundwater level declines in the Tucson area (Arizona Water Commission Bulletin 9, February 1975). The depth of water in two wells in the Tucson area has increased from 210 to 231 feet and from 83 to 126 feet respectively between 1969 and 1974 according to the U.S. Geological Survey (USGS). Annual pumpage in the upper Santa Cruz basin has increased from about 160,000 acre-feet in 1950 to about 253,000 acre-feet in 1971.



Photo 3. Piles of Sand and Gravel Debris (Middleground).
The Low-Flow Channel is in Background.

The depth of groundwater in the basin was tested to a depth of 30 feet. In 10 test holes drilled, no groundwater was encountered. A 1972 USGS map indicates that the probable depth of groundwater in the basin is 100 to 200 feet.

5. Reclaimed Water Supply

Because of the critical groundwater shortages in the project area, alternative sources for the lake's water supply were investigated. Among the alternatives were secondarily treated waste water from Randolph Park Plant, blowdown water from the Tucson Gas and Electric Company, and storm water. The most feasible source was determined to be effluent from the Randolph Park Plant. This water source was recommended in the Letter Report submitted for review in May 1978.

Further investigations were made to determine the quantity and quality of this water source and the type of treatment necessary to bring the water to the standards required for recreation use. A study completed in November 1979 by Rod Gomez and Associates indicated that the Randolph Plant was not operating at its full capacity. The firm determined that construction of a lift station would be necessary to bring additional effluent to the plant, which processes 1 million gallons per day (mgd). In order to get enough surplus effluent for a 60-acre lake, the plant's capacity would have to be increased to 1.5 mgd.

Alternative water treatment methods also were investigated. It was determined that land treatment was the most economically feasible method to bring the effluent to Environmental Protection Agency (EPA) recreation water standards.

Further elaboration of this proposed treatment method will be found under the description of the plan. (See Chapter 3, C and D.)

6. Soils

The soil of the basin is predominantly clayey sands, with irregular occurrences of sandy clays and borderline sands that average 10 percent moisture content. Materials in the southern half of the basin are cemented to some degree by caliche, a soil cemented by calcium carbonate. (See the Soils Investigation Report, Corps of Engineers, September 1977.)

There are no mineral deposits in the basin site. The soil is strongly calcareous and is moderately alkaline, with a pH between 7.9 and 8.4. It has high corrosivity to uncoated steel and low corrosivity to concrete.

7. Archeology

There are no records of archeologic sites or other cultural resources in the detention basin itself. There are, however, two Hohokam shard sites, circa 900-1300 A.D., within one mile of the detention basin. One of the sites, occupied by an abandoned service station,

is at the southwest corner of Ajo Way and Palo Verde Road; the other site is north of Irvington Road between Country Club Road and I-10, on the north bank of Julian Wash.

8. Vegetation

During construction of the detention basin, in the mid-1960s, the site was cleared of all native vegetation (predominantly creosote-scrub). Since then, both the increased moisture resulting from flood control and lack of routine maintenance have resulted in diverse and lush native plant growth. (See photo 4.) This new vegetation is markedly different in species composition from that of the surrounding area.

Although it must be classified as a disturbed area, the site appears to be a transitional zone between desert grassland and forest community. This condition is the direct result of the additional available moisture. Such zones often occur in areas where human activities have changed the drainage pattern of the landscape.

On the levee walls where moisture is scarce, the vegetation consists of grasses, shrubs and a few cholla cactus (*Sorghum*, *Phalaris*, *Baccharis*, *Psilostrophe*, *Opuntia*, and *Larrea*). (See photo 5.)

On the inner slope of the northwest levee, the vegetation cover is noticeably denser. This is a result of the prevailing pattern of drainage toward the Santa Cruz River. On this slope creosote bush, palo verde and mesquite trees are found. The bottom of



Photo 4. Typical Vegetation in the Tucson Detention Basin. Types in foreground are (from left) cholla cactus, mesquite tree and desert broom.



Photo 5. Grasses and Shrubs on Levee Walls
Where Moisture is Scarce.

the basin is covered with tall shrubs (*Baccharis*) and annual grasses, which are gradually being covered with sediment brought in by storm runoff. In isolated depressions scattered throughout the basin, there are tree species (members of the deciduous riparian forest communities), that include cottonwood, mesquite, tamarisk, and palo verde. Some are over 20 feet tall. (See photo 6.)

9. Wildlife

The diverse vegetation and increased moisture availability have created an area of rich wildlife habitat. The safety fence surrounding the project has discouraged public use and permits the various species of birds and mammals to inhabit the area with a minimum of human disturbance. During site investigations, jack rabbits (*Lepus*), quail (*Lophortyx gambelii*), and a few lizards were seen. It is reasonable to assume that animals such as javelina (*Peccari*) and deer (*Odocoileus*) once inhabited the site but have since been displaced by urbanization. In addition, this riparian forest habitat is probably a nesting site for game birds, including whitewing doves (*Zenaidura asiatica*) and the previously mentioned Gambel's quail.

10. Visual and Spatial Quality

The visual quality of the basin is relatively high when contrasted with that of the surrounding landscape and land use. The open space around the perimeter of the basin is covered with creosote-scrub vegetation, which is rather monotonous in character. To



Photo 6. Palo Verde Trees on the Northwest Levee.

the north and west, residential property consisting of lower income single-family homes, fences, and backyard alleyways can be seen from the levees of the basin. (See photo 7.) To the east, the industrial property is a decided contrast to the basin: the view in this direction is of tall storage tanks, warehouses, and powerlines. (See photo 8.) To the south, the county facilities are unobtrusive: the large county hospital is the visually dominant element of the group.



Photo 7. On the North Levee, Looking Northwest to the Residential Area.



Photo 8. Looking Across the Detention Basin to the Industrial Area on Country Club Road.

From the 20-foot levee walls, all areas surrounding the basin, as well as all points in the basin, are clearly visible. These levee walls also screen the activities within the basin, except for isolated views available to motorists on Ajo Way.

The detention basin's visual quality is good because of the vegetation. Its diversity in size, shape, and color adds to the visual interest of the flat site. The large Baccharis shrubs, which dominate the bottom of the basin, create a tall cover of bright evergreen shrubs. Because they are higher than eye level, these shrubs create spatial diversity and offer a sense of discovery for a visitor. This is important because the vast expanse of the basin is sometimes overwhelming to the first-time visitor. Some tall tamarisk, palo verde, and mesquite trees add a vertical dimension. The canopy of trees provides shelter and pleasantly modifies the scale of the basin. (See photo 9.)

Low-lying annual grasses create a rich texture on the ground plane. Their annual character provides color and height variations throughout the year.

Noise in the basin is significantly reduced, because of the levee walls. But jet noise from Davis Monthan Air Force Base occasionally will interrupt the basin's prevailing sense of tranquility.

Plate I illustrates the significant site features found in the Tucson Detention Basin.



Photo 9. Canopy of Tall Mesquite Trees Enhances the Basin.

B. SOCIAL AND ECONOMIC FACTORS

1. Population Characteristics

Eastern Pima County has nearly 500,000 people. By 2000, the population of Pima County is expected to grow to 746,000. The minority populations of this region reflect the historic cultures of the area. Approximately 20 percent of the residents are Spanish or Mexican; approximately 3 percent are Native American Indian; 3 percent are Black; and the remaining 74 percent are Anglo-Americans. Senior citizens in Pima County comprise 10 percent of the population; between 1970 and 1975, this age group increased by 27 percent.

2. Education and Income

The preferred types of recreation and rates of participation are closely related to a population's education and income levels.

The average adult educational level in the community is higher than national or state averages. The 1976 statistics show that 80 percent of the Tucson residents over 25 years old had graduated from high school. In 1970 the figure was 60 percent.

The area's median income is also on the increase. Family median income increased 36 percent between 1970 and 1976 and is now comparable to those of other growing metropolitan areas of the Southwest.

3. Existing Land Use and Patterns of Growth

The detention basin is surrounded by single family residential property on the north and west boundaries. Within this area are a junior high school and Thomas Park, a local neighborhood park. On the east boundary is industrial property. To the south are county-owned property and facilities, which include a Department of Motor Vehicles, Juvenile Detention Center, County Hospital, and Communications Center.

Ajo Way and Country Club Road, which are two-lane streets in each direction, are the main corridors to the project site. Interstate 10, 1 mile to the south, is a major regional and state transportation route.

From a regional land use standpoint, the detention basin is in what is termed "the core" of Tucson. The pattern of growth in this area is relatively stable. The suburbs to the south, southwest, and southeast of the basin are growing and expected to continue growing.

4. Economic Factors

Several economic factors play a significant role in the recreation planning of all projects.

The rate of inflation and concomitantly rising construction costs are reducing the spending power of available funds. It is necessary to plan and construct new facilities expediently.

The increasing costs and uncertain availability of gasoline will reduce willingness to travel to recreation facilities. Therefore it is important to develop facilities close to urban populations.

5. Recreation Trends

In the Tucson region participation in all forms of outdoor recreation activities has been growing.

Some of the significant trends in recreation include the following:

- Increased numbers of senior citizens and a growing need for recreation and social opportunities that are tailored to their interests.
- Increased participation of women in all forms of recreation.
- Increased participation by the physically and mentally handicapped. It has been estimated that there are 18,000 physically handicapped persons in the metropolitan Tucson area.
- A need for recreation opportunities for the preteen and teenage groups. The people of Tucson believe recreation opportunity might help reduce crime rates and keep these children out of trouble.
- Recreation activities of a cultural and educational nature are becoming increasingly popular among people of all social and economic levels.
- Increased participation in new or nontraditional activities such as hang gliding, roller skating, racquetball and volleyball.

6. Recreation Demand

Pima County and the City of Tucson have joined in a comprehensive planning effort to meet the growing recreation demand of the area. This effort has been summarized in the planning document "Parks, Recreation and Open Space: A Conceptual Plan", that was prepared in June 1978 (Briscoe, Maphis, Murray, Lamont, Inc. Key/Fletemeyer Assoc.).

This report indicates that recreation demand in this area is growing at an unprecedented rate. In 1977 nearly 80 percent of the households surveyed participated in outdoor activities. This participation has been increasing by 10 percent annually, more than 3 times the population growth rate. This rate is expected to increase fourfold by 2000.

According to the recreation survey, the average household now has someone visiting parks 373.88 hours annually. Half the household members would be expected to use parks to this extent. With a population of 502,700 (1978), and an average household size of 3 persons, a total of 93,974,738 hours are spent annually in parks in Tucson. Again from the survey, the average length of stay at a park is 6.1 hours. This translates to 15,405,695 annual visits to countrywide parks.

The city and county provide more than 80 free parks and recreation areas. (See plate 2.) Most of these facilities are urban-oriented neighborhood parks (5 to 14 acres). Some parks in the system serve district needs (15 to 100 acres) and others serve regional needs (over 100 acres).

Lake recreation is in short supply and in high demand in Tucson. Kennedy Park (3½ mi east) and Lakeside Park (6 mi west) provide lakes of approximately 12 surface acres. Kennedy Park cannot serve a total regional park function because its active recreation space is small. Pena Blanca Lake, 60 miles to the south, has 45 surface acres, with only small motor boats and nonpowered boats allowed. The most popular lakes are Roosevelt Lake and San Carlos Lake, which are a 2- to 3-hour drive from Tucson.

The 1978 county-city plan emphasizes a pattern of larger parks that serve district and regional needs. Larger parks can offer a greater diversity of activities and therefore attract more visitors. Capital improvement and operational costs are relatively smaller in larger parks.

The development of additional regional parks is required to meet population projections for 1985 and 2000. The 1978 plan recommends that the city and county develop two additional regional parks by 1985. The heavy use of Reid Park (3 miles west of the proposed project site) was a decisive factor in this recommendation.

Design criteria for future regional parks also was considered. It was suggested that 50 percent of the land in each park be devoted to unstructured open space with turf or native landscape.

Needed park features include such special interest areas as zoos, museums, botanic gardens, water attractions, and water-oriented recreation. Also needed are extensive picnic facilities in high quality environments.

Each park should be able to accommodate large group activities and have adequate onsite parking. Also needed are facilities for the preteen and teen-age groups, bicycle and equestrian trails, and areas for organized team sports. For example, there is an acute need for soccer fields, the emerging demand for which exceeds the existing park system's supply of open fields.

7. Competing Regional Parks

At present six parks in the City of Tucson and Pima County Park System offer regional park facilities. Three of these parks - Section 33, Arthur Pack Park, and Silverbell Park - are not

entirely developed. None of the existing regional parks offers a water-based recreation opportunity the size of the proposed detention basin project. Kennedy Park offers lake recreation, but the lake contains only 12 surface acres. Silverbell Park, which is under construction, will have 15 surface acres.

As for dryland recreation, Reid Park offers the widest diversity of recreation facilities. Its actual park area, excluding the golf course and ballfields, is frequently overcrowded, and its expansion is planned to serve inner city needs. Kennedy Park, while offering water-based recreation, is limited in its dryland active use areas. Much of the park land is devoted to natural areas. The Thomas Jay Park, which features an air museum, was not designed to serve a wide variety of regional park needs.

8. Potential Visitation

The proposed Tucson Detention Basin is designed to serve the entire metropolitan Tucson area. Its service area population is 502,700 (1978). Annual visitation for the facilities is projected to be 132,480 persons after initial development of Phase I.

C. RESOURCE BASE SUMMARY - OPPORTUNITIES AND CONSTRAINTS

The Tucson Detention Basin is in the rapidly growing Tucson metropolitan region. Its mild desert climate has attracted its share of sun belt migrants and recreation enthusiasts. As a result of the growth, Tucson faces a critical groundwater overdraft problem. Because of new growth, precious water resources can no longer be justified for recreation lakes or esthetic purposes. Alternate sources such as reclaimed water are considered more appropriate for these uses, which are much in demand.

The detention basin is a manmade flood control facility that serves its primary function well. It is also a potentially valuable recreation resource: its original excavation produced large expanses of flat land, suitable for a variety of purposes. Moreover, it is screened from street-generated noise by the 20-foot levees that surround the basin. There is good access from Ajo Way and Country Club Road. Highway I-10, only 1 mile to the south, will accommodate regional and tourist traffic.

The basin is adjacent to county-owned land. Facilities include a hospital, Juvenile Detention Center, Department of Motor Vehicles, and Communications Center. More facilities are planned. The entire area has the potential to become a major county facility-regional park, in which the various land uses could complement each other.

The Detention Basin now contains an abundance of beautiful native vegetation, which serves as rich wildlife habitat and provides scenic and spatial diversity with its varied form and color. The shade canopy of the trees also is a special recreation resource in the hot desert environment.

The demand for all forms of recreation, especially water-based and active sports areas, far exceeds the local agencies' facilities. They estimate that two additional regional parks are needed to meet the 1985 demand.

D. RESOURCE USE OBJECTIVES

The goal of proper resource use objectives is to match the available resources with the existing and projected recreation demand of the area involved. Mitigation measures to be used in case of adverse environmental impacts also are included in these objectives. The resource use objectives for the detention basin are summarized below.

In the preceding chapter, an evaluation and inventory have been made of the environmental, social, and recreation factors that will influence the development proposed at the Tucson Detention Basin. That evaluation produced the following resource use objectives.

1. Basic Objectives

- To maintain the Detention Basin's primary purpose as a flood control facility by designing and constructing recreation facilities that do not decrease its efficiency or capacity.
- To maintain and enhance the basin's biological resources and to develop compatible recreation facilities at the same time.
- To develop a multiple-use recreation facility that will provide a diverse array of recreation opportunities and attract more users.

2. Resource Use Goals

- To provide a park and recreation facility that is in harmony with the desert environment. The desert climate is one of the factors most conducive to enjoyable recreation. Its mild winters and hot summers permit year-round participation. But its climate also presents some obstacles; scarcity of water and extreme heat make traditional grass-and-tree parks popular, but difficult and costly to maintain. The water issue is the most sensitive environmental issue associated with the project. Tucson already faces a severe ground-water overdraft problem. The citizens will not allow ground-water to be used for the proposed lake. Until an adequate alternative water source that meets EPA standards has been found to supply the lake's water, future development of this feature will not proceed. Other proposed park facilities requiring fresh water – such as playing fields, trees, and restrooms – will be designed to be water-efficient.
- To use and preserve the basin's natural resources, especially vegetation and wildlife habitat, and incorporate them into the final project design. The existing vegetation constitutes a valuable recreation resource. Native species such as mesquite,

palo verde, and tamarisk have survived and flourished with available storm runoff. The trees provide shade and shelter for the existing wildlife and also could allow limited passive recreation use.

- To develop the facilities that will be subjected to more intensive use on areas that are free from hydraulic constraints. The area adjacent to the inlet structure will have the most severe hydraulic constraints. A levee will be built to convey nuisance and low flows around the active use areas, and divert them into the nature area. Here the water and sediment deposits will cause little damage or maintenance problems, while supplying moisture and nutrients to the plants.
- To develop intensive use facilities in areas that have been heavily disturbed in recent years. The county highway department has extracted large quantities of sand and gravel from the northeast portion of the basin. Large spoil heaps remain. This area will need regrading to make it usable. Therefore the most extensive grading and development are proposed for this sector.
- To develop a master plan that allows flexibility in design. The proposed development is designed to be built in phases because of financial limitations. But it has been designed to be a viable park facility, regardless of how many phasing options are ultimately exercised.

3. Objectives Related to Land Use Allocation

The basin has been designed as a multiple-use facility that will provide a diverse array of recreation opportunities from the very active to the very passive. The jogging and bicycle path will circle the basin and link all use areas.

Active use areas are proposed for the southeast portion of the basin, in close proximity to the access road and parking areas. The following facilities will be constructed in this area.

- A large group picnic area with barbeques and overhead ramadas. Large group picnic facilities to host civic group get-togethers such as Kiwanis Club Pancake Breakfast. These facilities will be near a restroom and a number of active sports facilities.
- A spectator-seating area for athletic events. A limited section of the levee walls will be reconstructed to provide a large spectator seating area. This will allow for audience participation in the field events below. The proposed seating will face the northeast, to minimize sun angle problems for the spectators.
- Multiple-use fields designed for soccer, football, and baseball will be located below the seating area.
- An exercise and fitness trail will be provided for use by both the able-bodied and the handicapped.

Moderate to heavy uses could be provided in connection with the development of a recreation lake, as follows.

- A boating and fishing lake could be excavated at the basin's lowest elevation. The lake could be zoned for boat activity that ranges from active (motor) to passive (sail).
- Lakeside picnic areas, as well as riding and hiking trails, could be built to complement the adjacent water activities and exploit good views.
- A boat-launching and fish-cleaning area could be developed in connection with the other lake-oriented activities. Access to the boat-launch area could be designed so that it would not interrupt circulation through the rest of the park.
- Family picnic units would be located near the lake. Barbecue grills and picnic ramadas would be located within a relatively short walking distance.
- A nature area would be reserved primarily for its value as wildlife habitat. Minimally developed pedestrian trails would also be provided for wildlife observation. This area would provide a floral backdrop on the north side of the lake.

III. THE PLAN

This section describes the land use plan for the Tucson Detention Basin.

A. EXISTING RECREATION USE OF TUCSON DETENTION BASIN

No public access is permitted to the detention basin. A chain link safety fence has been constructed around the project to discourage entry. Thus, no authorized recreation occurs within the basin.

B. PROPOSED RECREATION DEVELOPMENT

Recreation development in the Tucson Detention Basin will occur in two major phases: (1) creating dryland recreation facilities; (2) subsequent construction of a multiple-purpose lake and additional dryland facilities. (See plates 3 and 4.)

1. Low-Flow Channel

In the initial phase of development, a low-flow channel will be constructed to convey flows of up to 300 cubic feet per second (ft^3/s) around the multiple use field areas and along the edge of the proposed nature area. When flows exceed this amount they will move to the western portion of the basin, which is its lowest point. Only native seeding is proposed for this area so that plant life or facilities will not be damaged by inundation.

In the second phase of development, when the low-flow is exceeded, the flows will go directly into the lake.

2. Dryland Recreation

The initial recreation development will provide for active uses: picnic facilities, bicycle trails, exercise fitness trails, par course for the handicapped, spectator seating for sports events, concrete areas for various games, large turfed areas for football, baseball, and soccer, an archery range, and a nature area. A paved access road, parking areas, restrooms, and service roads also will be built.

Additional dryland facilities will be developed in conjunction with the multiple-purpose lake development. The bicycle and hiking trail will be expanded around the lake's edge. Additional picnic areas will be developed adjacent to the water-related activities area. A boat dock and fish-cleaning area will be part of the lake edge development. An additional restroom will be constructed to accommodate visitors to the lakeside area.

C. STORM WATER

The characteristics of the storm water entering the basin will vary considerably, depending on the time of the year and quantity of flow. Storm water occurring after a considerably dry period will contain a greater concentration of pollutants than will storm water occurring later in the year. The exact characteristics of the storm water have not been measured, but it is assumed that the major concentration of pollutants would be the first flow to enter the basin.

D. COST-SHAREABILITY OF PROJECT FEATURES

The following determination of the cost-shareability of proposed project features is based on the Veysey Guidelines, dated 2 June 1976.

1. Land Acquisition

Phase I recreation development in the Tucson Detention Basin will occur within the existing project boundaries.

2. Access, Parking, Restrooms and Upper Picnic Areas

These facilities have been located on the southeast portions of the project lands. The major point of access to the project is from Country Club Road. These items are cost-shareable, according to the Veysey Guidelines.

3. Other Project Features

All other features of the proposed plan are cost-shareable items, including the picnic facilities, restrooms, access roads, multiple-use fields, concrete playing areas, spectator seating area, jogging and bicycle paths, parking areas, lighting, and landscaping.

4. Project Operation and Maintenance

Operation and maintenance costs would be the responsibility of the local agency.

E. PLANNING/DESIGN CRITERIA

Planning criteria for Code 710 development is to be in accordance with ER 1120-2-400, "Investigation Planning, and Development of Water Resources - Recreational Resources Planning". Detailed design criteria is to follow ER 1110-2-400, "Design of Recreation Sites, Areas and Facilities", and ER 1110-1-102 and EM 1110-1-103, "Design for the Physically Handicapped". Design and construction under the Code 710 program is to adhere to local building requirements and, in some cases, reflect stricter Corps standards.

F. PROPOSED DEVELOPMENT SCHEDULE

The proposed recreation facilities will be constructed in two phases. Construction of the proposed recreation facilities will begin during the first fiscal year funds are available. Future facilities will be developed under the Code 710 cost-sharing program only if both local and Federal funds are available.

G. FACILITY DEVELOPMENT

The recreation and support features of the proposed development have been broken down into phased development. These phases are outlined in the following paragraphs and are shown on plates 3 and 4.

1. Phase I

The first development phase is to include the following features:

a. Low-Flow Channel

A low-flow channel will be built along one side of the nature area. The channel, which will have a maximum height of about 4 feet, is to be capable of routing 300 ft³/s from the inlet channel to the outlet channel. The channel design will follow the guidelines set forth in EM 1110-2-1913, dated 31 March 1978. Once the channel is built, flows in excess of 300 ft³/s will drain into the native seeded area at the west end of the basin. Native landscaping and rocks and boulders will be incorporated into the design of the low-flow channel to make it look like a natural streambed.

b. Access Roads

There will be one vehicular entrance to the proposed site: an east entrance from Country Club Road. A single, 2-way, 24-foot-wide asphalt cement access road will reach all recreation areas in the basin. The access road, which will have asphalt curbs and gutters, will be designed in accordance with Department of the Army TM5-887-1, Chapter 1, "General Provisions and Geometric Design for Roads, Streets, Walks, and Open Storage Areas." Secondary gravel service roads will be provided in use areas, as needed, but will not be for public vehicular use. About 2000 feet of roadway will be constructed under initial development, and an additional 500 feet of roadway will be constructed under future development.

c. Parking

Under ER 1110-2-400, a single 10- by 20-foot parking space will be provided for each picnic site. These standards meet the local agency's standards for parking lot development. A number of parking spaces will be designed for the handicapped.

d. Paved Trail/Service Road

An 8-foot-wide asphalt cement riding and hiking trail will be an integral part of the circulation system of the proposed project. The trail also will act as a service road for park maintenance. So that pleasurable trail use will be maintained throughout the park, the trail will not exceed a grade of 15 percent. Total length of the completed trail will be 5000 feet.

e. Jogging and Bicycle Path

A graded, naturally surfaced jogging course will encompass the detention basin. This trail will be approximately 2 mi long. Signs, a drinking fountain, and a rest area will be provided along the route.

f. Fitness Trails

An exercise and fitness course is proposed for the outside edge of the multiple-use field area. This trail will be 0.5 mi in length and designed so the handicapped can use one segment of it.

g. Restrooms

Two restrooms will be in the picnic area, easily accessible from the parking lot and sports facilities. Their design will reflect the southwestern architecture style. Natural materials will be used for esthetics, low maintenance, and antivandalism qualities. The criteria used to estimate quantities and locate facilities are within the guidelines set forth in ER 1110-2-400. Two restrooms will be constructed under Phase I and one under future development.

h. Group Picnic Area

Ten group picnic tables and five group picnic ramadas are proposed. This group picnic area will seat up to 250 people.

i. Family Picnic Areas

In these areas, there will be 14 family picnic tables and 10 group picnic tables. They will be clustered to offer the flexibility required to accommodate groups of various sizes. All tables will be designed for the handicapped. There will be 20 grills and 7 drinking fountains. Picnic ramadas with individual table, barbecue grill, refuse container, and drinking fountain will be provided throughout the recreation area. The design of the ramadas, which will reflect the southwestern architecture style, will have a modular construction concept that minimizes construction costs. Picnic ramadas will be built.

j. Spectator Seating

A combination slope and terrace turf area will be incorporated into the levee walls. These areas can seat more than 500 people and will be constructed according to Corps standards. From these areas, the spectators may watch activities on the multiple-use fields, concrete playing areas, fitness trails and lake.

k. Multiple-Purpose Fields

Soccer, baseball, football, and frisbee are among the many uses of this grassed area.

l. Bicycle Motocross

Among the creosote and baccharis shrubs on the northeast side of the park, a series of hills and jumps will be constructed to function as a bicycle motocross. It can be used by individuals or in conjunction with competition events.

m. Archery Range

Archery facilities for field and target archery will be provided in the west end of the basin, where there will be minimum contact and conflict with other uses.

n. Landscaping

Native and drought-adaptive trees and shrubs will be used as landscape elements. Proposed is a plant palette, consisting of mesquite, palo verde, tamarisk, smoke tree, ironwood, poplar, and some species of eucalyptus. These trees will provide a visual continuity with the existing vegetation. Turf areas will be planted with bermuda grass.

o. Irrigation System

Proposed are drip irrigation systems for the drought-adaptive tree species, and flood or spray irrigation for the field areas.

p. Electricity and Lighting

Security lighting will be provided at all recreation buildings and facilities. Lighting also will be installed along walkways and at parking lots. The bicycle trail will not be lighted, but lighting is proposed for the multiple-purpose fields for night use. Wiring will be placed underground, and connections will be made with existing municipal distributions. About 75 percent of the electrical work and lighting will be completed initially. The rest will be completed under a future phase.

q. Concrete Playing Areas

Paved areas for basketball, tennis and volleyball will be adjacent to the multiple-purpose fields. There will be areas for shuffleboard and horseshoes.

r. Tot Lot

An assortment of prefabricated play structures will be placed in the center of the picnic area. The ground treatment of the tot lot will be sand.

2. Future Development

Once an adequate water supply has been provided and project funding obtained, a future phase of development will include the following facilities.

a. Lake

The lake will function primarily as a multiple-purpose facility, intercepting and dissipating flood flows from the Tucson Arroyo and Railroad Wash drainage areas. The lake will cover about 60 acres; depth of the lake will vary as necessary to provide advantageous habitat for fish and wildlife, but will average about 9 feet. The lake will be used for boating and fishing; swimming will not be permitted. Proposed facilities will include a boat-launching ramp and a fish-cleaning area. The embankment for the lake will be equipped with both an inlet and an outlet structure. During floods, the outlet structure will be capable of emptying the basin as fast as it does now. The lake, the embankment, and the inlet and outlet structures will be constructed during the second phase of development.

b. Lakeshore Picnicking

Family and group picnic facilities along the lakeshore are proposed. These are to include picnic ramadas, barbecue grills, and trash receptacles.

c. Restrooms

An additional restroom will be built to accommodate lakeside visitors. It will be above the 100-year flood elevation.

d. Landscaping

Additional landscaping, using the same plant palette described in paragraph I.1.n., will be installed in the second phase. The bank along the lake will receive the most extensive landscape treatment.

e. Irrigation

Additional irrigation is proposed for the landscaping in the second phase of development.

f. Lighting

In the second phase, lighting is proposed for the bicycle and hiking trail along the lake edge.

Because of the lack of economic justification, the Federal portion of the recreation costs exceeding 10 percent of the flood control costs, and the lack of an adequate water supply, the lake is currently recommended as a local cost. All other facilities included in the plan are cost-shareable.

IV. SPECIAL PROBLEMS

A few special problems will need to be resolved so the recreation resources of the Tucson Detention Basin can be fully developed.

A. CONSTRUCTION COSTS ASSOCIATED WITH FUTURE LAKE RECREATION DEVELOPMENT

Both the Corps and Pima County Parks and Recreation Department are well aware that the construction costs of the lake exceed the recommended benefit-cost ratio. The Corps recommends that Phase I dryland recreation be approved as presented, and the future lake development be approved in concept only. No Federal participation is recommended at present for the future development phase. Local interests may construct the facilities on their own. If conditions change to warrant Federal participation a supplement to this master plan will be prepared.

The estimated construction costs do not reflect the following possibilities that could substantially lower costs for future lake development:

- Potential market value for borrow material from lake excavation. Costs for lake excavation could be lowered or eliminated if the borrow material were exchanged for lake excavation work.
- Discussions with Metropolitan Utilities Management staff indicate that requests have been made to have the capacity of the Randolph Park treatment plant increased. (CBEA Feasibility Study, January 1976). A viable consideration to meet the needs of the city, as well as the county, would be the addition of phosphorus removal, sand filtration, and chlorination. It would reduce or eliminate the need for a tertiary treatment facility at the lake.

If and when the lake development becomes economically justified a supplement to the master plan and a FDM will be prepared, detailing plans.

B. ALTERNATIVE DESIGN OPTIONS FOR FUTURE RECREATION DEVELOPMENT

The master planning process has carefully considered design options for the second phase of recreation development. In the event that future lake development is not implemented because of prohibitive costs, a viable dryland regional park can be expanded. Phase I recreation development has anticipated this possibility in its design. This alternative is also supported by the local sponsors of the project because state and local recreation studies indicate a need for additional dryland facilities in the region.

V. AGENCY COORDINATION AND PUBLIC INVOLVEMENT

The Corps of Engineers, the Pima County Parks and Recreation Department, and representatives of the City of Tucson met with the general public and representatives of interested agencies and groups to discuss the feasibility of developing a multiple-purpose recreation/wildlife lake in the Tucson Detention Basin. These meetings were held on 21 and 29 September, and 17 November 1977, in Tucson.

At these public meetings, the proposed plan developed by CBEA was described and discussed. The public was informed that the Corps will continue to study the original feasibility plan and, through this present master plan, determine its feasibility; will develop an array of possible alternatives (i.e., lake size other than 60 acres); will address concerns regarding groundwater use, evaporation rates, environmental factors (e.g., suitability of the water as fish habitat); and will develop cost estimates for the project proposed by CBEA.

During continuing studies, the District will stress the need either to reduce the present groundwater requirement of the proposed plan, or to keep it at its present level. The District also will look at ways to make the proposed lake a viable fish habitat. Various methods of creating a wildlife habitat (e.g., by creating an isolated shoreline along one side of the lake) will be investigated.

The Corps will continue to involve the public in this planning process.

VI. COST AND RECREATION BENEFIT ESTIMATES

The following text considers costs and benefits of the project.

A. COST ESTIMATES

The Board of Supervisors of Pima County has indicated a willingness to enter into a cost-sharing agreement with the Corps of Engineers to secure construction funds for the proposed recreation development. A 3-year program and associated annual cost estimates were discussed with Corps representatives and subsequently outlined in two Letters of Intent, dated 2 June 1976 and 9 September 1976.

As a result of the Rod Gomez and Associates Feasibility Report, dated November 1979, costs for the initial development have since been re-estimated. No lake development could be built with the funds that the local agency allocated in its 1976 Letters of Intent. Therefore, the Corps has recommended a two-phase program. Dryland recreation will be constructed in the first phase. Then the lake, treatment facility, and additional dryland recreation development will be built in future development. The Board of Supervisors has examined this change in phasing and has approved the revised concept.

Under the Code 710 program, the Federal Government and Pima County will share the cost of developing those features that have been determined to be cost-shareable. Estimated Federal and local costs for Phase I development are shown in table 1.

Table 1. Estimated Cost of Phase I Recreation Development.

(All Figures are October 1979 Estimates.)

Item No.	Description	Estimated Quantity	Unit	Unit Cost	Total Cost
1	Group Ramadas, 38 ft x 32 ft	5	Each	22,600	113,000
2	Family Picnic Ramadas, 19 ft x 16 ft	10	Each	9,000	90,000
3.	Group Picnic Tables (precast conc. 20 ft x 3 ft x 4 in with conc. benches)	10	Each	1,022	10,220
4	Family Picnic Tables (precast conc. 10 ft x 3 ft x 4 in with conc. benches)	10	Each	682	6,820
5	Restrooms 26 ft x 34 ft	2	Each	40,000	80,000
6	Multiple-purpose Courts	1	Job	LS	50,000
7	Multiple-purpose Fields	1	Job	LS	50,000
8	Jogging and Bicycle Path (graded 8 ft wide)	1	Mile	1,170	1,170
9	Grills	20	Each	100	2,000
10	Refuse Containers	20	Each	75	1,500
11	Drinking Fountain	10	Each	350	3,500
12	Parking Facilities	2,200	Yd ²	6.50	14,300
13	Access Roads, 24 ft wide	5,300	Yd ²	7.30	38,700
14	Paved Trail Service Road 8 ft wide	4,400	Yd ²	6.50	28,600
15	Parking Lighting	10	Acre	4,400	44,000
16	Park Signs	1	Job	LS	1,000
17	Trees - 15 gal	200	Each	75	15,000

Table 1. Estimated Cost of Phase I Recreation Development. (Continued)
 (All Figures are October 1979 Estimates.)

Item No.	Description	Estimated Quantity	Unit	Unit Cost	Total Cost
18	Trees - 5 gal	150	Each	15	2,250
19	Grading	30	Acre	1,500	45,000
20	Site Clearing and Grubbing	30	Acre	400	12,000
21	Turf w/Automatic Irrigation	28	Acre	14,000	392,000
22	Spectator Seating	1	Job	LS	45,000
23	Fitness Trails	1	Job	LS	8,000
24	Low-Flow Channel 4 ft high x 10 ft wide x 2,440 ft long	3,540	Yd ³	2.25	8,000
25	Archery	1	Each	3,000	3,000
26	Tot Lot	1	Each	10,000	10,000
27	Bicycle Motocross	1	Job	LS	1,605
	Subtotal				<u>\$1,076,700</u>
	20% contingencies				215,300
	10% Engineering and Design				129,200
	6% Supervision and Administration				77,500
	Total Construction Cost for Recreation Facilities (Phase I)				<u>\$1,500,000</u>

B. RECREATION BENEFITS

The determination of recreation benefits for development of the Tucson Detention Basin was undertaken in accordance with the Water Resources Council procedures for evaluation of National Economic Development (NED) benefits and costs. The methodology employed determined both a user-day value for each activity and the number of visitor days annually provided by the project. Full use of the project facilities is not achieved until the sixth year of project operation. It can take that long to develop public awareness of project features provided.

1. Benefit-Cost Analysis

The development of overall costs included the following: an analysis of the cost of advanced waste water treatment required for the water-based recreation; cost of recreation features; operation and maintenance for the recreation and treatment facilities; and cost of water used to provide the water-based recreation. Because the treatment facilities will not be necessary without the recreation lake, the total cost of advanced sewage treatment is a project cost. Five factors were included in determining user-day values for the various recreation opportunities. These include relative scarcity, ease of access, esthetic attraction, extent of facility development, and availability of complementing activities.

2. Development of User-Day Values

The project provides for less than 500,000 annual visits and less than \$750,000 annual recreation costs. The unit-day value method of recreation valuation was used. Table 2 shows the type of recreation, criteria points by judgment factor, total points, and unit value.

Table 2. User Day Values.

Activity Type*	Judgment Factors**					Total	Value per Unit (\$)
	A	B	C	D	E		
Picnic	13	2	8	14	11	48	2.25
Court Use	10	2	7	14	9	42	2.00
Field Use	10	4	7	14	9	44	2.05
Jogging	10	5	5	8	7	35	1.80
Spectator Seats	3	2	5	11	7	28	1.60
Par Course	3	3	5	7	6	24	1.55
Boating	11	11	7	12	9	50	2.51
Fishing	11	7	7	12	10	47	2.45
Tot Lot	5	2	5	5	7	24	1.55
Fishing-Shore	8	5	7	12	10	42	2.00

*All recreation activities are general in nature.

**Judgment factors are the following:

- A - Recreation experience; B - Availability of opportunity;
- C - Carrying capacity; D - Accessibility; and
- E - Environmental quality.

3. Phase I

Initial Phase I development of the Tucson Detention Basin includes picnic areas, fields, concrete playing areas, a 2-mile jogging trail, and a 500-seat spectator seating area. Table 3 lists the costs and associated benefits for the Phase I development.

Table 3. Phase I Benefits and Costs.
(7 1/8%, 100-Year Analysis.)

Project Costs							
First Cost of Recreation							\$1,500,000
Annual Cost							106,900
Operation and Maintenance (3% of first cost) . . .							45,000
Total Annual Charges							\$ 151,900
Ultimate Annual Recreation Benefits							
Use	Units	Density	Turn-over	Factor*	Annual User Days	User Day Values	Annual Benefits
Picnicking (R = 8)	20	7.5	2	96	28,000	2.25	\$ 64,800
Courts	5	4	3	108	6,480	2.00	12,960
Fields	5	10	3	108	16,200	2.05	33,210
Jogging (M = 12)	2 mi	20	5	135	27,000	1.80	48,600
Spectators	1	500	1	108	54,000	1.60	86,400
Total					132,480		\$245,970
$* \text{FACTOR} = \frac{R \times N}{M \times W}$							
<p>R = Ratio of duplication (0.9 unless otherwise indicated) N = Number of weekend days in peak month (9) M = Proportion of annual recreation visits in peak month (0.15 unless otherwise indicated) W = Proportion of peak month visits on weekends (0.5)</p>							

Table 3. Phase I Benefits and Costs. (Continued)
(7 1/8%, 100-Year Analysis.)

Average Annual Benefits (Phase I)	
First-year benefits (246,000 ÷ 2)	\$123,000
5-year maximization factor @ 7 1/8%	.820988
Product	101,000
First-year benefits	123,000
Total equivalent annual benefits	\$224,000
Phase I Annual Benefits	224,000
Phase I Annual Costs	152,000
B/C Ratio	1.5
Net Benefits	72,000

4. Future Development

Future development includes the construction of additional general recreation facilities, construction of a 60-acre lake, a pumping station to deliver up to 0.5 mgd of additional effluent to the Randolph Park treatment plant, an ammonia-stripping facility, and a tertiary land treatment facility.

The proposed lake will be lined, to prevent effective percolation of water. There will be an evaporative loss of 446.9 acre-feet annually from the lake. There also will be a reduction of ground-water recharge of 416 acre-feet annually as a result of the project. Pumping costs for groundwater in Tucson averages \$40 per acre-foot. To provide water for recreation use, the alternative to effluent use is groundwater. Cost for the recreation water supply is \$16,600 annually.

VII. COST-SHARING UNDER THE CODE 710 PROGRAM

The Tucson Detention Basin project's cost-shareable features are summarized in table 4.

Table 4. Phase I Cost-Shareable Features.

Description	Federal	Pima County
Phase 1 Development (Cost-Shareable Features)	\$750,000	\$750,000
Phase 1 Development (Noncost-Shareable Features)	0	0
Total, Initial Development	\$750,000	\$750,000

VIII. OPERATION, MAINTENANCE AND MANAGEMENT

This section details the objectives, concepts, policies, and other aspects of recreation facility operation, maintenance and management.

A. GENERAL

The operation, maintenance and management of all recreation facilities constructed under project authority cited in the introduction will be the responsibility of local interests.

The Pima County Board of Supervisors provided a letter of intent on 18 January 1980, indicating its intent to act as the local sponsoring agency. The letter of intent is included as appendix A. The Board of Supervisors has reviewed and approved the draft cost-sharing agreement.

The Corps of Engineers will prepare a project resource management plan, in accordance with ER 1130-2-400 and ER 1165-2-400. The management plan will be developed within one year after completion of the initial recreation facility construction for Phase I. When completed, the management plan will be included as an appendix to the master plan.

B. MANAGEMENT OBJECTIVES

The natural and manmade resources of the Tucson Diversion Channel project area will be managed for the enjoyment of the public, consistent with their carrying capacity, and their esthetic and ecological values. This policy will be achieved by compliance with the following objectives.

- Protect project visitors and employees.
- Improve and protect project resources; enforce zoning requirements to avoid conflict between recreation uses and ecologic preservation.
- Insure compatibility between recreation uses and equipment provided for the recreation activity.
- Improve the project environment with landscape treatment, including retaining existing vegetation, planting native species and traditional park plantings of turf and shade trees.
- Encourage local officials to adopt and enforce zoning and building codes to control private developments adjacent to the project, and thus avoid problems of water pollution, visual pollution, or the use of project roads for access to private property.

C. OPERATIONAL CONCEPTS AND POLICIES

In accordance with the recreation cost-sharing agreement, operation and maintenance of recreation facilities will be the responsibility of Pima County. Decisions regarding the types of facilities planned in the project area have been closely coordinated with local interests. Operation and management of these facilities, a local responsibility, should be similar to that of like facilities in the area that are operated and maintained by Pima County. Policies regarding the operation and maintenance of the recreation resources will be established by the Corps of Engineers and the local sponsor with full regard for the primary project purpose of flood control.

Uses compatible with the character of the Phase I concept will be established and encouraged within the project areas and on adjacent lands. Protection and enhancement of environmental quality will be a primary objective of Pima County.

D. ADMINISTRATION

Administrative duties for the recreation facilities will rest with the Pima County Parks and Recreation Department.

E. STAFFING AND ORGANIZATION

The management of the Tucson Diversion Channel recreation areas will be the responsibility of the Pima County Parks and Recreation Department.

F. LAW ENFORCEMENT

Law enforcement in the project area will be the responsibility of Pima County.

The project areas will be patrolled regularly by local police. Security lighting will be provided. Public telephones, strategically located in or near the recreation areas, will assist visitors in emergencies.

G. SAFETY

Signs, markers and physical barriers will be provided throughout the project area. They will control pedestrian and vehicle traffic; also, they will warn the public of the potential hazard of the flood-detention basin.

IX. CONCLUSIONS AND RECOMMENDATIONS

The following text gives the conclusions and recommendations reached in the master plan study.

A. CONCLUSIONS

This master plan has presented a comprehensive strategy for recreation development in the Tucson Detention Basin. The following conclusions were reached.

- While the detention basin will maintain its primary function as a flood control facility, recreation development can be successfully integrated to provide a valuable recreation resource for the Tucson metropolitan region.
- The planning process used in the development of this master plan evaluated and analyzed numerous factors, including hydraulic constraints, economic, social, and biologic factors, to yield a feasible development strategy.
- The proposed recreation facilities reflect needs found in both local recreation planning studies and in the Arizona Statewide Comprehensive Outdoor Recreation Plan.
- The proposed plan will enhance the environmental resources of the detention basin.
- The proposed plan will function well and its maintenance will not overtax environmental or energy resources.

B. RECOMMENDATIONS

Approval of this master plan is recommended for the following reasons:

- The existing flood control basin will now function as a multiple-use facility, optimizing the use of the land.
- It will help meet the recreation needs of a growing metropolitan area.
- It has been proven an economically viable investment in terms of benefit-cost analysis (Phase I).
- It will serve as a guiding document for the preparation of the FDM and Plans and Specifications.
- It will also serve as a guiding document in the overall development and management of the Tucson Detention Basin.
- The District recommends that Phase I dryland recreation be approved as presented.

- The District recommends the future phase of development be approved in concept only. While this development is desirable, it must have economic justification, be within the 10 percent Veysey guidelines limitation or approval for exceedance, and have an adequate water supply before Federal participation is warranted.

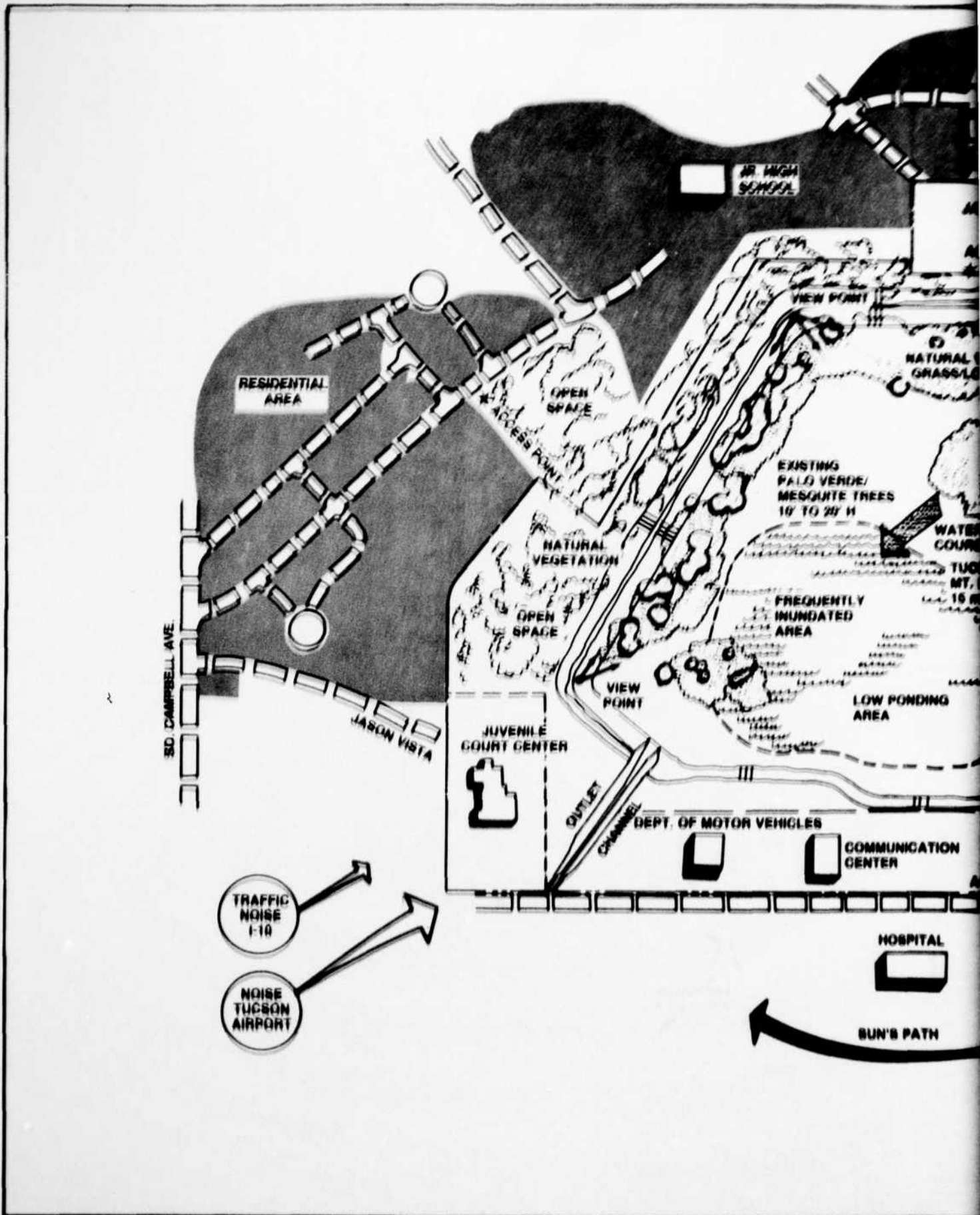

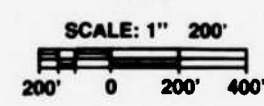
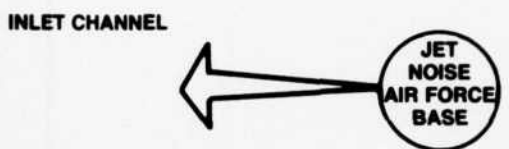
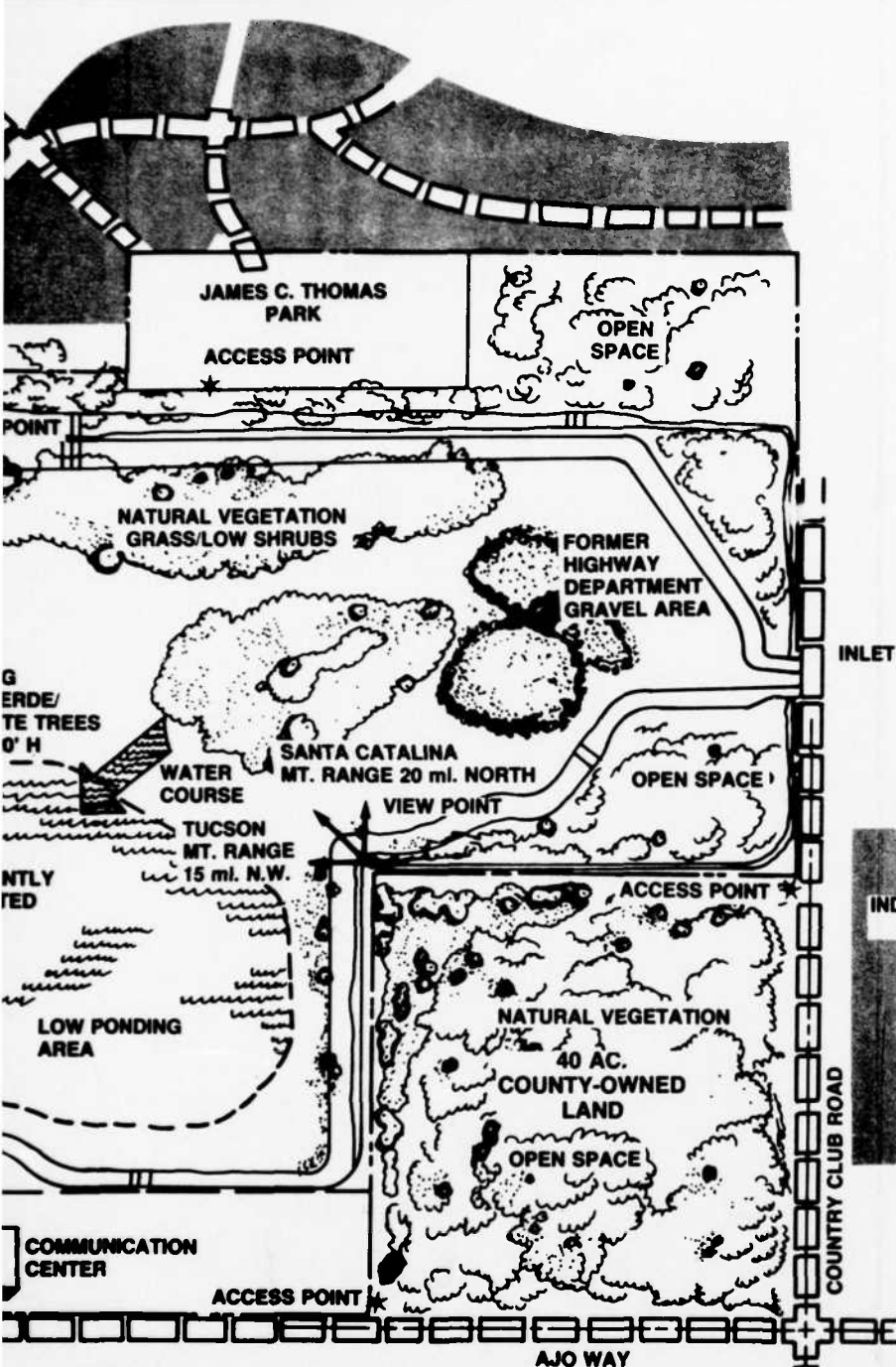

GILA RIVER and TRIBUTARIES ARIZONA and NEW MEXICO
TUCSON DIVERSION CHANNEL
 recreational development program
 u.s. army corps of engineers los angeles district

SITE ANALYSIS



AN 4157
MAY 1961
A. PARSONS

TICOM
MILITARY
1961

AN 14511

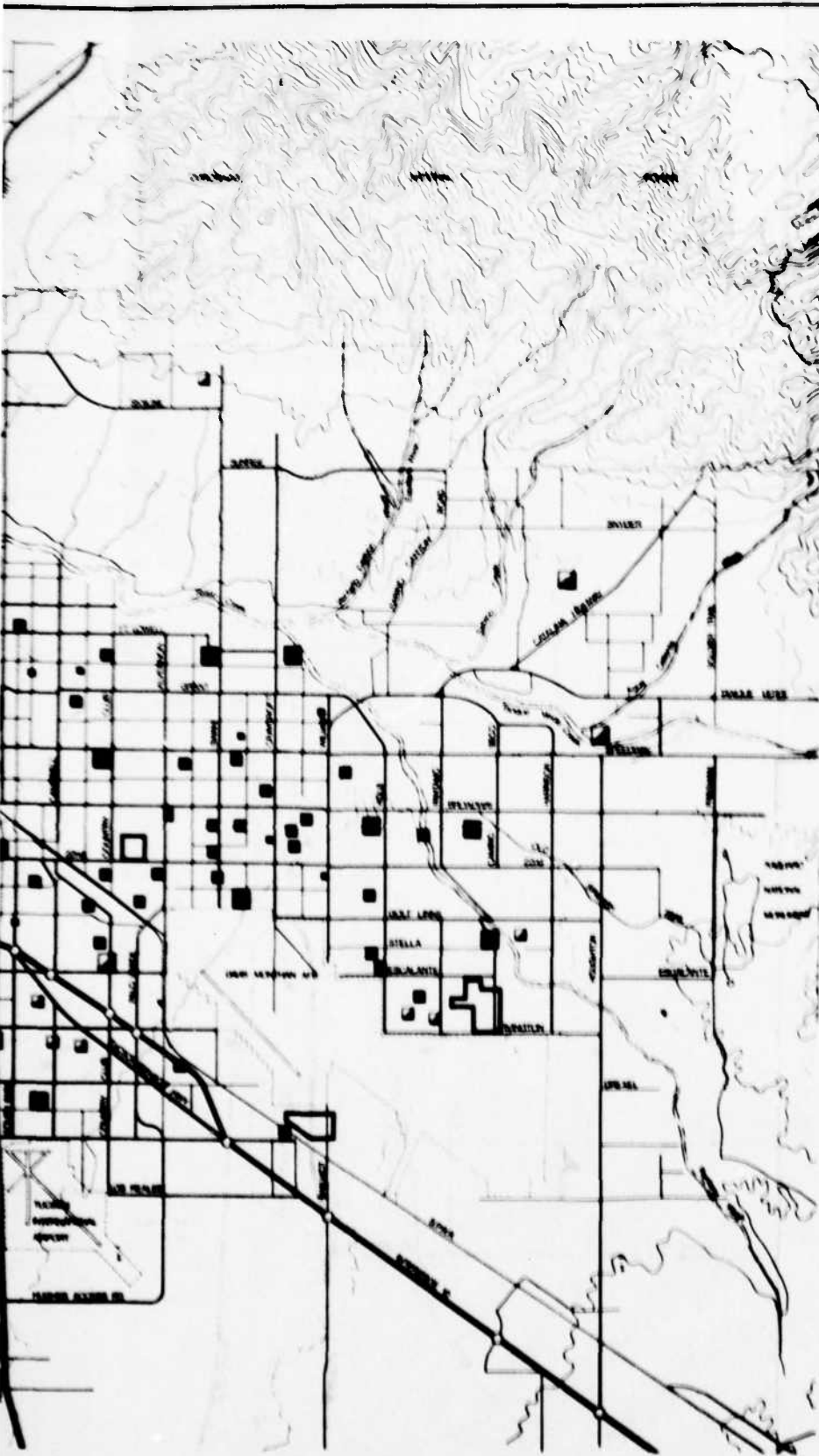

- Interstate Highway
- Major Highway
- Arterial Street
- Collector Street

- | Facility | Developed | Undeveloped |
|-------------------|-----------|-------------|
| Metro Park | | |
| Neighborhood Park | | |
| District Park | | |
| Regional Park | | |



GILA RIVER and TRIBUTARIES ARIZONA and NEW MEXICO
TUCSON DIVERSION CHANNEL
 recreational development program
 u. s. army corps of engineers los angeles district

EXISTING PARKS

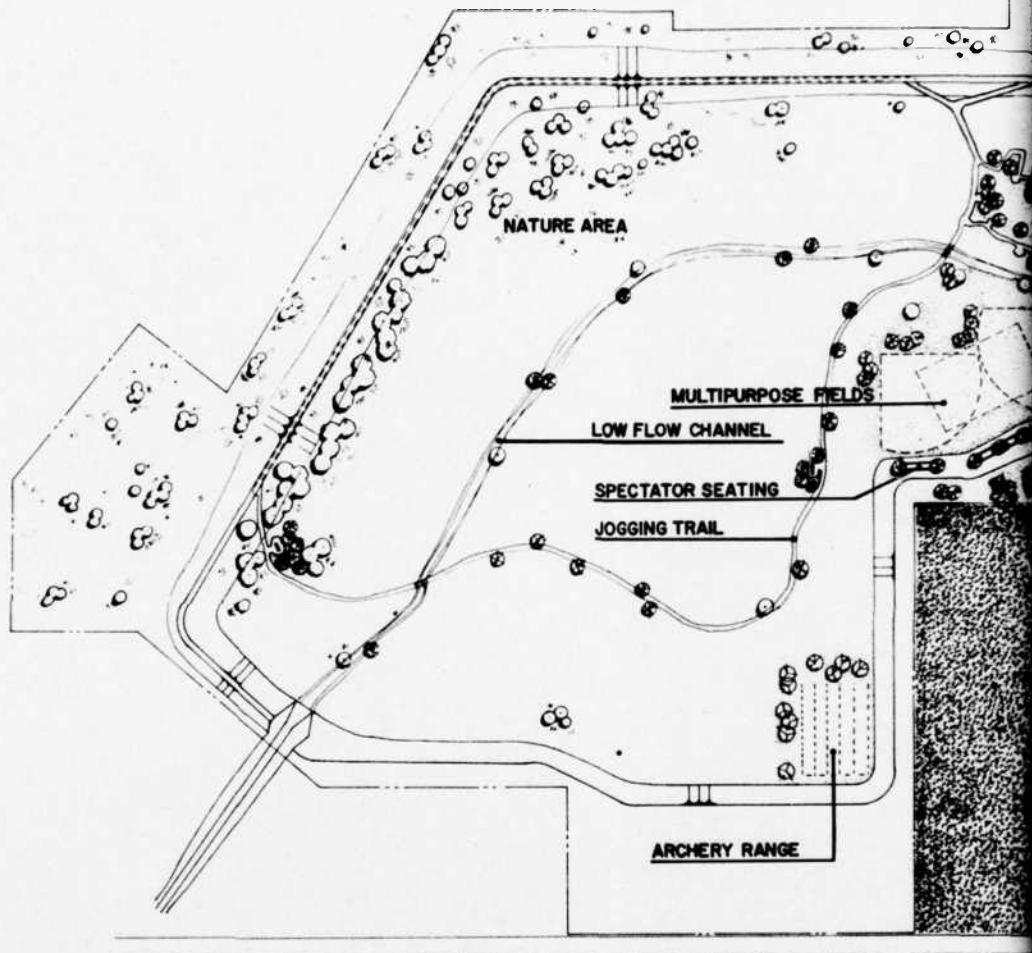

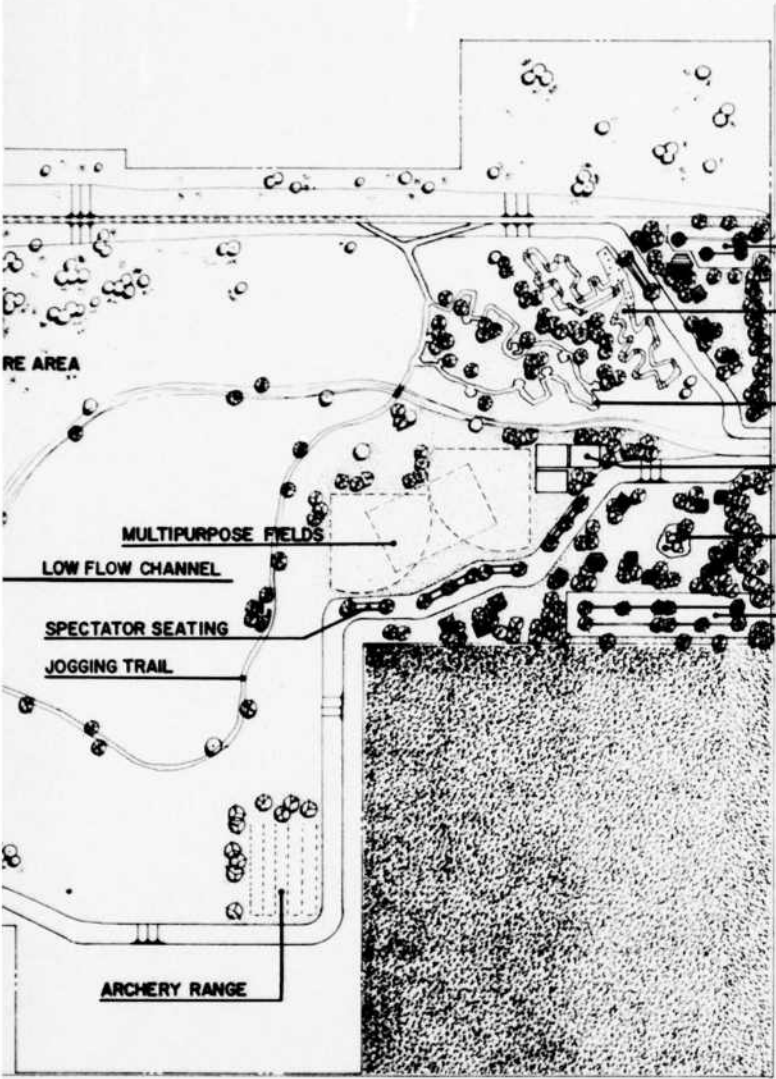

PARKING
 BICYCLE MOTOCROSS
 FITNESS TRAIL
 MULTIPURPOSE COURTS
 TOT LOT
 PARKING

LEGEND

- PROJECT LIMITS
- NATIVE VEGETATION (EXISTING)
- PROPOSED LANDSCAPE
- RESTROOM
- GROUP PICNIC RAMADA
- PICNIC RAMADA
- FITNESS STATION
- FITNESS TRAIL
- REST AREA
- JOGGING TRAIL
- EXIST. LEVEE / JOGGING TRAIL
- 40 AC. COUNTY - OWNED LAND



AJO WAY

COUNTRY CLUB

SCALE : 1" = 200'
 200' 0 200' 400'

GILA RIVER and TRIBUTARIES ARIZONA and NEW MEXICO
TUCSON DIVERSION CHANNEL
 recreational development program
 u.a. army corps of engineers los angeles district

RECOMMENDED PLAN
FOR RECREATION PHASE 1

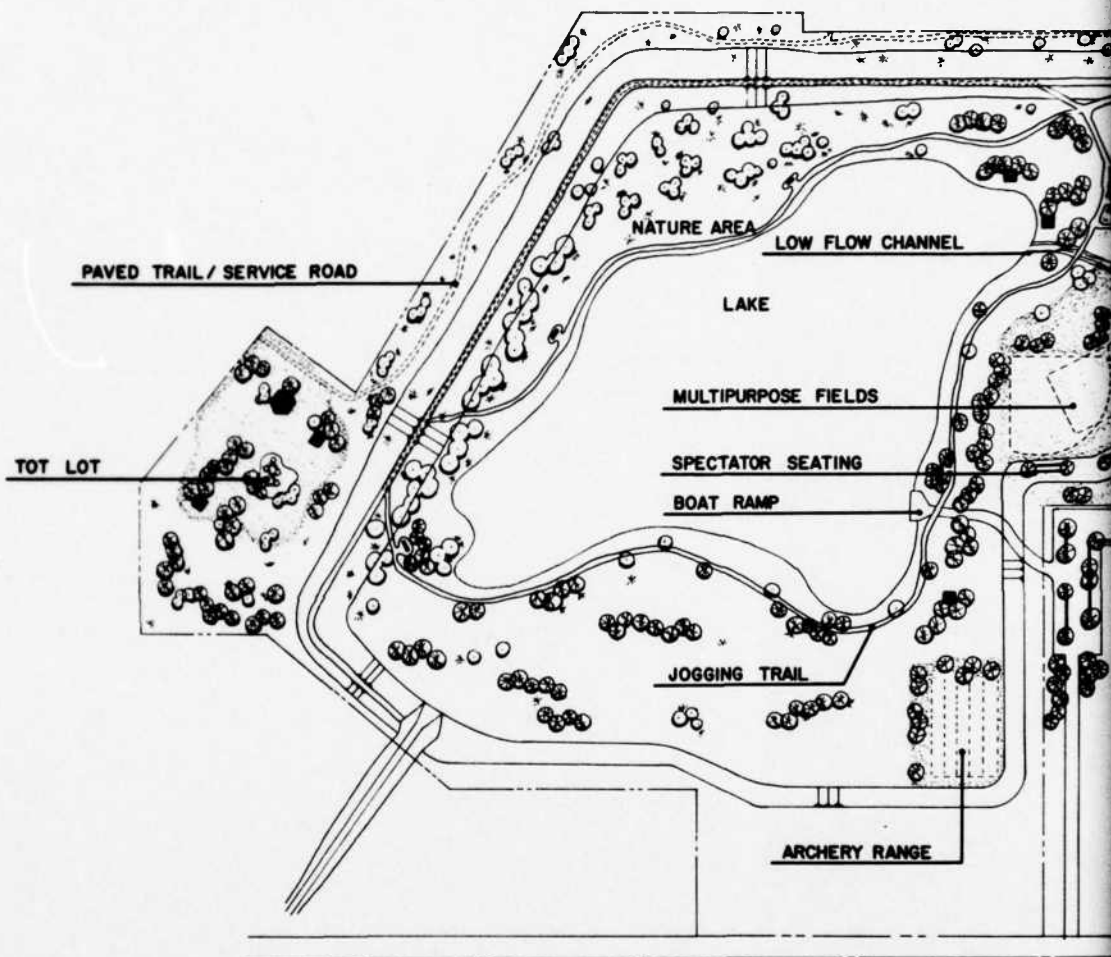

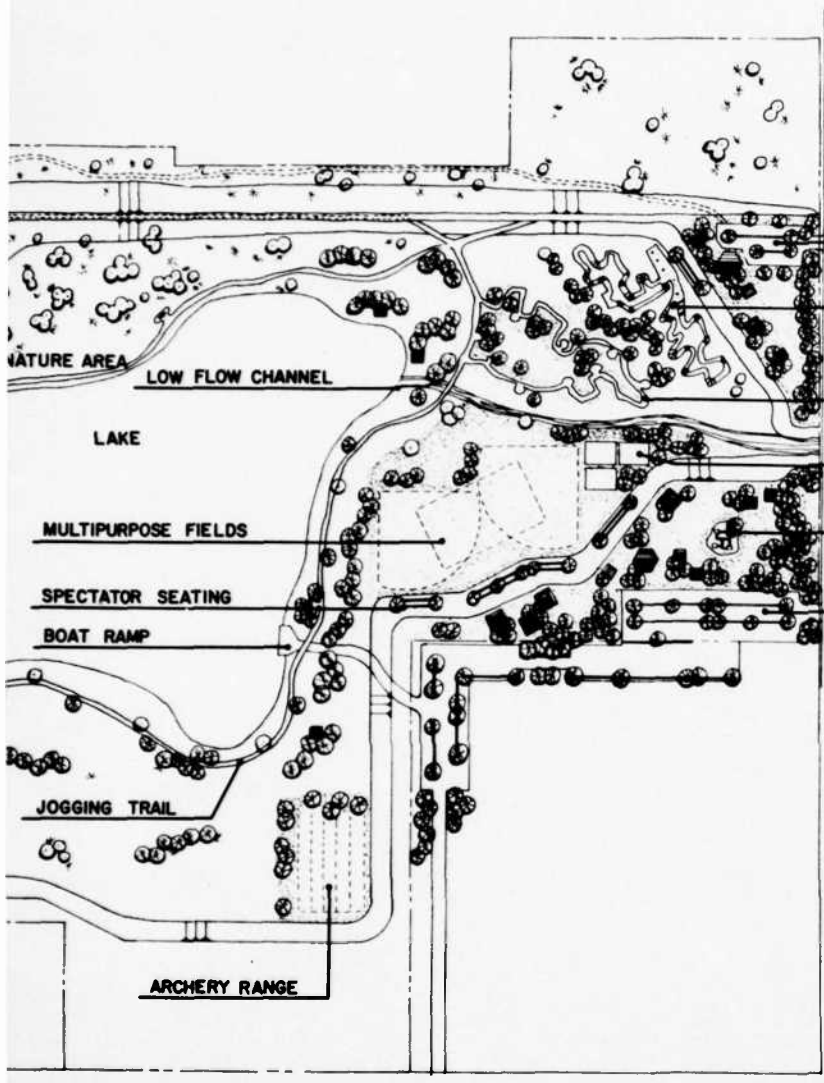

PARKING

BICYCLE MOTOCROSS

FITNESS TRAIL

MULTIPURPOSE COURTS

TOT LOT

PARKING

- LEGEND**
- PROJECT LIMITS
 - NATIVE VEGETATION (EXISTING)
 - PROPOSED LANDSCAPE
 - REST ROOM
 - GROUP PICNIC RAMADA
 - PICNIC RAMADA
 - FITNESS STATION
 - FITNESS TRAIL
 - REST AREA
 - JOGGING TRAIL
 - EXIST. LEVEE / JOGGING TRAIL



AJO WAY

COUNTRY CLUB

SCALE · 1" = 200'

200' 0 200' 400'

GILA RIVER and TRIBUTARIES ARIZONA and NEW MEXICO

TUCSON DIVERSION CHANNEL

recreational development program

u.s. army corps of engineers los angeles district

RECOMMENDED PLAN

FOR FUTURE RECREATION

1

2

APPENDIXES

APPENDIX A
PERTINENT CORRESPONDENCE

A copy of the "Tucson Diversion Channel Recreation Development Program," March 1980, along with a cover letter soliciting comments, was sent to all the public agencies involved in the project. Following are all the responses received.



PIMA COUNTY
OFFICE OF THE COUNTY MANAGER

131 W. CONGRESS, 11th FLOOR
TUCSON, ARIZONA 85701
(602) 792-8661

January 18th, 1980

Col. Quinn A. Teague
District Engineer
Department of the Army
L.A. District Corps of Engineers
P.O. Box 2711
Los Angeles, California 90053

Re: Ajo Detention Basin, Tucson Diversion Channel Project

Dear Colonel Teague:

The Pima County Board of Supervisors, at a meeting on Tuesday, January 15th, 1980, approved the concept plan as presented by Mr. Tom Luzano, Project Manager, Corps of Engineers, and Ms. Gail Vanderbie, Corps of Engineers, for the design and construction of a dry park alternate with criteria that water use facilities be included for future incorporation at the Ajo Detention Basin.

It is the County's understanding that the Corps will immediately proceed with hiring an architect engineer for the design of the above project. At the January 15th meeting, the Board of Supervisors also authorized the commitment of \$750,000 in existing bond monies for this project, with the understanding that the Corps of Engineers will match \$750,000 from their 710 Project, so that this project may proceed as soon as possible.

We appreciate the opportunity to proceed with this project, and your great cooperation in bringing this project to fruition. If you need any further clarifications or assistance, please do not hesitate to contact myself, or Gene Laos, Parks and Recreation Director.

Col. Quinn A. Teague
District Engineer
Department of the Army

January 18th, 1980
Page 2

Thanking you in advance for the expeditious handling of this project.

Sincerely,



Craig A. McDowell
County Manager

CAMc:mp

cc: Dennis Majors
Corps of Engineers
Los Angeles District

Gene Laos
Director
Pima County Parks & Recreation

PIMA COUNTY PLANNING AND ZONING DEPARTMENT

PIMA COUNTY GOVERNMENTAL CENTER • 131 WEST CONGRESS STREET • TUCSON, ARIZONA 85701



April 17, 1980

Norman Arno
Chief, Engineering Division
Corps of Engineers, Los Angeles District
Department of the Army
P.O. Box 2711
Los Angeles, CA 90053

RE: Master Plan-Tucson Diversion Channel
(Recreational Development Program)

Thank you for the opportunity to comment upon the subject plan. The data presented in the report is comprehensive and clearly stated.

The general, overall concept of the plan is excellent and will serve many needs and purposes.

We are now in the process of formulating the "Southeast Area Plan", the western boundary of which is Country Club Road. The most densely populated portion of our plan area falls within a three mile radius of the Wet Park site.

Future actions relative to the development of the park will definitely impact planning decisions in the southeast area. We would appreciate being kept up-to-date on any changes or new developments regarding this project.

Sincerely,

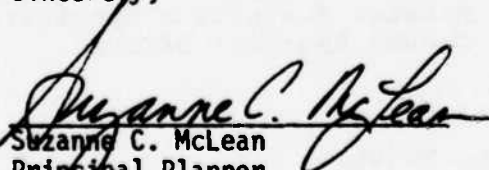
Suzanne C. McLean
Principal Planner

SCM/GHR/pah

Commissioners:

C. GENE TOLLE, Phoenix, Chairman
WILLIAM H. BEERS, Prescott
CHARLES F. ROBERTS, O.D., Bisbee
FRANK FERGUSON, JR., Yuma
FRANCES W. WERNER, Tucson

Director

ROBERT A. JANTZEN

Deputy Director

ROGER J. GRUENEWALD



ARIZONA GAME & FISH DEPARTMENT

2222 West Greenway Road Phoenix, Arizona 85023 942-3000

May 12, 1980

Mr. Norman Arno, Chief
Engineering Division
Department of the Army
Los Angeles District, Corps of Engineers
P. O. Box 2711
Los Angeles, California 90053

Dear Mr. Arno:

The Arizona Game and Fish Department has reviewed the Tucson Diversion Channel Master Plan. The concept behind this plan is excellent. The availability of additional water-related recreational facilities in the Tucson metropolitan area will enhance the quality of the community.

Tucson's need for this type of facility is increasing and our Department has recognized this need. We are currently evaluating an urban lakes fisheries research project. The results of this project will be incorporated into urban fisheries management plans in the near future. The Ajo detention facility would provide an additional urban fishery, and we support the concept of such facilities.

Thank you for the opportunity to comment on this plan.

Sincerely,

Robert A. Jantzen, Director

Vashti C. Supplee
Habitat Evaluation Specialist
Tucson Regional Office

VCS:dd

cc: Planning and Evaluation Branch, Phoenix

A-6

APPENDIX B
ENVIRONMENTAL ASSESSMENT
OF
RECREATION DEVELOPMENT
AT THE
TUCSON DETENTION BASIN

JANUARY 1980

PREPARED BY CLIFF RADER
ENVIRONMENTAL QUALITY SECTION

A. Description of Proposed Project. The proposed project is the development of a recreational lake and related dryland park facilities at the Tucson Detention Basin in South Tucson, Arizona. Due to a shortage of funds, the project will be developed in two phases: Phase 1 will consist of the construction of the dryland park facilities (e.g., picnic tables, turf fields, bicycle-motocross track); Phase 2 will be the construction of a tertiary sewage treatment plant and a 60-acre lake with supporting boating, fishing. Swimming will not be allowed. A more complete description of the proposed project can be found in the master plan. But because the project's design is still not finalized, only general comments about it will be made in this environmental assessment.

B. Description of Existing Environment.

1. *Setting.* The city of Tucson in southern Arizona, has developed into a metropolitan center of 500,000 people despite the desert environment and a limited supply of water. The Saguaro National Monument, which contains nationally renowned desert life forms, borders Tucson's east and west sides.

2. *Proposed Project Site.* The proposed project site is located in a relatively undeveloped area of South Tucson. There is residential development on the north and west of the detention basin, and commercial buildings on the east. But the south side of the basin has had very little urban development. A hospital, a juvenile detention facility, county motor vehicle registration offices, and a communication center are the only buildings to the south.

3. *Physical Characteristics.* The area of the detention basin is approximately 120 acres, surrounded by a levee about 20 feet high. The land within the basin is relatively level. A low flow channel crosses the middle of the basin from the inlet structure on the northeast to the outlet structure on the southwest. The poor elevation gradient does not allow for proper drainage, and therefore the southern half of the basin periodically ponds because of storm flows.

4. *Sand Extraction Operation and Borrow Pit Excavation.* A former sand extraction operation and borrow pit excavation are located in the southeast part of the basin, about 300 feet from the inlet structure, on approximately 8 acres.

5. *Vegetation.* The detention basin supports an assemblage of desert-grassland plant species that differ significantly from those found in the areas surrounding Tucson. Instead of containing the Saguaro cactus (*Carnegiea gigantea*) that predominates elsewhere, the detention basin is characterized by mesquite (*Prosopis* sp.), palo verde (*Cercidium* sp.), and desert broom (*Baccharis* sp.). In addition, a small number of cottonwood (*Populus* sp.) trees are growing near the inlet.

6. *Desert "Riparian" Community.* This desert "riparian" community is probably caused by the additional moisture resulting from the impounding water in the detention basin. Several grasses, including Johnson grass (*Sorghum* sp.) and canary grass (*Phalaris* sp.) are growing in the areas where water is periodically confined.

7. *Creosote Bush-Scrub Community.* A creosote bush-scrub community is located on lands outside of the detention basin levees.

8. *Fauna.* Animal species present in the detention basin are typical of desert environments. Brief field observations included sightings of large numbers of jackrabbits (*Lepus* sp.) and Gambel quail (*Lophortyx gambelii*). Ground squirrels and a few lizards were also seen.

9. *Endangered Species.* No rare or endangered animal or plant species are known to exist in the project area.

C. Environmental Impacts.

1. *Habitat Loss.* Development of the detention basin for the specified recreation designs would cause a severe reduction in the habitat value of the area. At present, the basin serves as a refuge for fauna within the urban confines of Tucson. The introduction of recreation facilities and associated large numbers of people will not be compatible with the easily disturbed animals now present. Moreover, a large portion of the natural vegetation will be removed during the development of the recreational facilities. The design plans for landscaping with native vegetation and preserving existing vegetation along an approximately 200-foot wide strip bordering the northern and western levees and to landscape with native vegetation to lessen the impact of vegetation loss. But despite the preservation of this plant life, the expected high visitor rates in this area will disturb any remaining fauna.

2. *Change in Habitat by Creation of 60-Acre Lake.* Creating a 60-acre lake within the desert environment will cause a major change in the existing habitat. Although the area is now periodically inundated with storm waters, the proposed lake will exist year-round. Because of the volume of water, available moisture in this area will increase dramatically. The species composition will change with the introduction of waterfowl and fish. Native animal species remaining in the area will be only those tolerant of human activity.

3. *Lake Construction.* The construction of the lake will require the excavation of approximately 800,000 cubic yards of material. At present, plans call for using 400,000 cubic yards of material on site for fill and esthetic mounding. An additional 400,000 cubic yards of material will be relocated to the adjacent county-owned land. But the disposal of this material will result in the loss of approximately 40 acres of creosote-bush habitat.

4. *Water Usage.* The city of Tucson has in recent years become increasingly aware of its dwindling water supply. Its rapid population growth and expansion of agriculture and business has caused a dramatic increase in the demand for water. This increased demand has significantly reduced the ground water reserves on which Tucson relies solely for its water supply. Present estimates indicate that the water table has fallen from 10 to 40 feet in various places during the past 5 years. In view of the fragile nature of Tucson's water supply, therefore, any proposal to alter water usage patterns should be carefully examined.

5. *Filling of the Lake.* The initial filling of the lake will require approximately 400 acre-feet of ground water. Evaporation will cause the water level in the lake to drop each summer. The project design calls for the construction of a tertiary sewage treatment plant to ensure that there will be enough water to fill the lake each winter. This plan will treat excess secondary-treated effluent from the nearby Randolph Treatment Plant. Right now the excess effluent is discharged into the Santa Cruz River. Diverting the excess secondary-treated effluent (approximately 40 acre-feet/year) to the proposed tertiary treatment plant will mean that 40 acre-feet of water per year will no longer be available for recharge into the ground water table downstream of Tucson.

6. *Improvement of Present Sewage Collection System.* In order to provide enough water for all proposed usages, the present sewage-collection system must be improved so that the treatment plant can operate at maximum capacity. After water is supplied to other parks in the area, approximately 450 acre-feet per year of tertiary-treated water will be available for the lake. This, of course, represents a potential loss to groundwater recharge, because this water probably would have been recharged to the groundwater table if it had not been collected by the improved sewage system and diverted to the sealed-bottom lake.

7. *Transportation.* The development of the proposed park will increase traffic level within the area. It appears, however, that the existing roads will be able to absorb any expected increases.

8. *Noise.* Ambient noise levels are expected to increase both during and after construction of the proposed park, potentially affecting nearby residents and the hospital. Aircraft from Davis Monthan Air Force Base and Tucson Airport will fly overhead on occasion. But generally flight patterns do not cross the project.

9. *Air Quality.* Construction activities will create a temporary decrease in air quality levels.

10. *Cultural Resources.* The proposed activity is not near any of the sites listed or eligible for listing in the National Register of Historic Places.

D. Conclusion. The Environmental Assessment has determined that no significant impact upon the quality of the human environment is expected from the proposed activity. Therefore, an Environmental Impact Statement will not be prepared. Should significant additional information be developed concerning the proposed action or should the proposed action be significantly modified, the effect of the action will be reevaluated. A supplemental assessment, which may conclude that as EIS is required, will then be prepared.

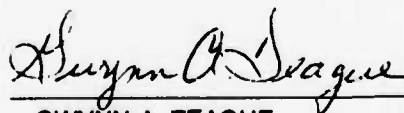

GWYNN A. TEAGUE
Colonel, C E
District Engineer

7 March 1980.

Date

APPENDIX C
SOILS REPORT
(ATTACHED REPORT IS NOT EDITED.)

SOILS INVESTIGATION REPORT

TUCSON DIVERSION CHANNEL

DETENTION BASIN LAKE

SEPTEMBER 1977

U. S. ARMY ENGINEER DISTRICT, LOS ANGELES

CORPS OF ENGINEERS

SOILS INVESTIGATION REPORT

TUCSON DIVERSION CHANNEL DETENTION BASIN LAKE

INTRODUCTION

1. Authorization. This report is submitted in accordance with Service Request No. ED-E-77-39, dated 20 June 1977.
2. Purpose and scope. The report describes and presents the results of subsurface explorations conducted to establish soil types and conditions in the area of proposed construction. The report recommends (a) the allowable soil bearing capacity, (b) a vehicular pavement design, (c) alternative treatments for lake linings, (d) the location of a designated borrow area for lake lining construction, and (e) inlet erosion control measures. A supplemental report offering specific recommendations for a lake lining treatment with erosion control, along with riprap requirements would be submitted upon receiving detailed project criteria.
3. Site description. The location of the proposed project is in the detention basin of the Tucson Diversion Channel located in the southern portion of Tucson, Arizona. It lies within the Santa Cruz River drainage area. The topography is generally flat within the boundaries of a twenty foot wide berm around the perimeter of the basin. Shallow rooted scrub

growth, approximately six feet high, covers the northern one third of the basin and a ten foot deep borrow pit has been excavated in the northeast corner near the inlet. The remainder of the basin interior is essentially level and free of vegetation.

INVESTIGATIONS

4. Explorations. A subsurface exploration at the site of the proposed project was conducted during June 1977, using a power auger with a 16-inch diameter bucket. Ten test holes, TH 77-1 through TH 77-10, were drilled to depths of 30 feet. Standard penetration tests were conducted in each test hole. In these tests, a 140-pound hammer, with a 30-inch free fall, was used to drive a standard sampling spoon having an outside diameter of 2 inches and an inside diameter of 1-3/8 inches. A record was made of the number of blows, N, required to advance the sampler one foot after the spoon was seated 6 inches into the bottom of the hole. The locations of the test holes are shown on plate 1. The materials encountered were visually classified and disturbed samples of representative materials were obtained for laboratory classification tests, moisture content determinations and compaction tests.

5. Laboratory tests. Mechanical analysis, Atterberg limits, moisture content determinations and compaction tests have been conducted on representative samples in accordance with EM 1110-2-1906. The soils were classified in accordance with the Unified Soil Classification System.

Results of tests are presented in the logs of test holes shown on plate 2.

6. Foundation conditions. The materials predominantly consist of clayey sands with minor occurrences of sandy clays and borderline sands. Moisture contents averaged 10 percent and ranged from 3 to 19 percent. Plasticity indexes ranged upwards to 28. The standard penetration tests revealed the sand materials to have relative densities ranging from medium dense to very dense and clay materials to have consistencies ranging from medium stiff to hard. In the southern half of the basin the materials are slightly to moderately cemented by caliche. Ground water was not encountered during the exploration. A proposed borrow area, designated for lake lining construction, is shown on plate 1 and consists of fine grained clayey sands and sandy clays. The plasticity indexes for the borrow range from 9 to 17.

7. Recreation lake. The initial lake concept consists of a surface area of 61 acres with a maximum depth of 30 feet. In order to estimate the seepage losses for the lake, a lining of compacted select material was first analyzed. The select material would consist of native silty and clayey sands and clays and silts. The lining thickness was a maximum of 6 feet along the bottom of the lake, tapering to 2 feet at the top. Permeability test results from the original Tucson Diversion Channel project were used in conjunction with current exploration materials and compaction data. The tests indicate that the lowest expected permeability for the lining would be about 0.02 feet per day when compacted to at least 95 percent of the maximum density (ASTM D 698)

at optimum moisture content. The expected seepage loss from the lake was calculated to be at least 1700 acre feet per year. In addition, the average annual evaporation loss is estimated to be 66 inches (340 acre feet per year) based on U. S. Weather Bureau sources. The expected seepage loss from a lake just consisting of 12 inches of compacted in-situ soil was calculated to be at least 10,000 acre feet per year.

DESIGN APPLICATIONS

8. Foundation design. Based on the results of the subsurface explorations and laboratory tests, the proposed structures may be adequately supported on continuous footings or thickened-edge slab-type foundations placed on undisturbed native materials or compacted fill. The allowable soil bearing capacity would be 1500 psf for footings based at a minimum depth of 12 inches below finished grade. Expected settlement due to the anticipated light footing loads would be negligible. It is recommended that the finished floor elevation of the structures be at least 6 inches above the surrounding grade. A vapor or capillary water barrier would not be required beneath slabs. All structural fills and backfills would be compacted to at least 95 percent of maximum density for a minimum depth of 3 feet below footings and within an area 5 feet outside of structures (ASTM D 1557). Other fills are considered non-structural and would be compacted to 90 percent of maximum density (ASTM D 698).

9. Flexible pavement design.

a. Design values. Based on test results on similar materials (clayey gravelly sands and clayey sands) a CBR value of 10 is adopted for the native

subgrade or fill from required excavation, compacted to 93 percent of maximum density.

b. Design criteria. The flexible pavement for the access roads and parking areas is designed in accordance with Department of the Army TM 5-822-5. No estimate of the frequency and type of vehicular traffic was furnished. The following assumptions must be verified by the project manager and the architect-engineer.

(1) Access roads. Class E road, traffic category III, design index 3.

(2) Parking areas. Class E road, traffic category I, design index 1.

c. Pavement section. The pavement sections required to satisfy the CBR and depth of compaction requirements are as follows:

(1) Access roads. A 1½-inch bituminous surface course, 5 inches of aggregate base course compacted to 100 percent of maximum density over 6 inches of subgrade compacted to 93 percent of maximum density (ASTM D 1557).

(2) Parking areas. A 1½-inch bituminous surface course, 4 inches of aggregate base course compacted to 100 percent of maximum density over 4 inches of subgrade compacted to 93 percent of maximum density (ASTM D 1557).

d. It is recommended that all the pavement sections be built-up at least 6 inches above the surrounding grade in order to provide adequate drainage of the pavement section.

10. Lake lining.

a. Alternative treatments. A lake lining would be required in order to minimize seepage losses. Five linings were analyzed and compared on a

cost versus seepage loss basis and consisted of the following treatments: (A) compacted select material, (B) enzymatic stabilized compacted select material, (C) a bentonite and select material mixture, (D) a bentonite membrane, and (E) a 20 mil PVC membrane. Typical sections of the linings are shown on figures 3 through 7. Table 1 summarizes the basis for estimating the lining costs, assuming the cross section to have 1V to 5H side slopes and a horizontal bottom.

Table 1

Lining Cross Sectional Data

<u>Lining Type</u>	<u>Bedding Material</u>	<u>Cover Material</u>
(A) Compacted select material, 2 to 6 ft thick	None required	None required
(B) Compacted select material with enzymatic stabilizer, 1.5 ft thick	None required	None required
(C) Bentonite-select material mixture, 2 in. thick	4 in./select	6 in./select
(D) Bentonite membrane, 4 lbs. per sq. foot	6 in./select	6 in./select
(E) 20 mil PVC	8 in./sand	8 in./select

b. Comparative costs. Seepage losses were calculated for water surface areas of 15, 31, 46 and 61 acres along with maximum water depths of 20 and 30 feet. Figure 1 graphically compares lining costs with seepage losses and suggests the use of a membrane type lining for minimum water

losses. Figure 2 compares the present worth of the various linings based on a 25 year life, 6 percent annual interest rate, and a water cost of \$250 per acre foot.

c. Design recommendations. A membrane type lake lining sandwiched within select material (see figures 5, 6, 7) is recommended. The recommendation will be confirmed, based on the final lake configuration, by a supplemental report. The lake side slopes would be no steeper than 1V to 5H. Select native material to be used in the lake lining would have at least 90 percent passing the No. 4 sieve, at least 30 percent passing the No. 200 sieve, and would be compacted to at least 90 percent of maximum density (ASTM D 698). Soil cement, grouted stone or other suitable treatments would be used as erosion protection for the liner where the filling water enters the lake and at the location of the overflow spillway. Erosion protection would be required along the shoreline within the zone of anticipated wave action where the zone of wave action is dependent on the lake size selected. A six inch layer of soil cement (8 percent by dry weight cement) would be adequate for erosion protection.

11. Lake berm. A berm would be required between the lake perimeter and the low flow channel. The channel-side slope would be no steeper than 1V to 3H. Materials for use in the berm construction may be obtained from required lake excavation and would be compacted to at least 90 percent of maximum density (ASTM D 698).

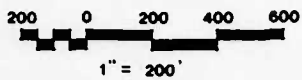

DETENTION BASIN EMBANKMENT

PROPOSED BORROW AREA

TH 77-1

TH 77-2

TH 77-5

TH 77-6

TH 77-7

TH 77-8

TH 77-10

LEGEND

TH 77-1
● LOCATION AND NUMBER

NOTES

1. TEST HOLES WERE DRILLED BY 6" DIAMETER BUCKET TYPE POWER AUGER
2. FOR LOGS OF TEST HOLES SEE ATTACHED LOGS

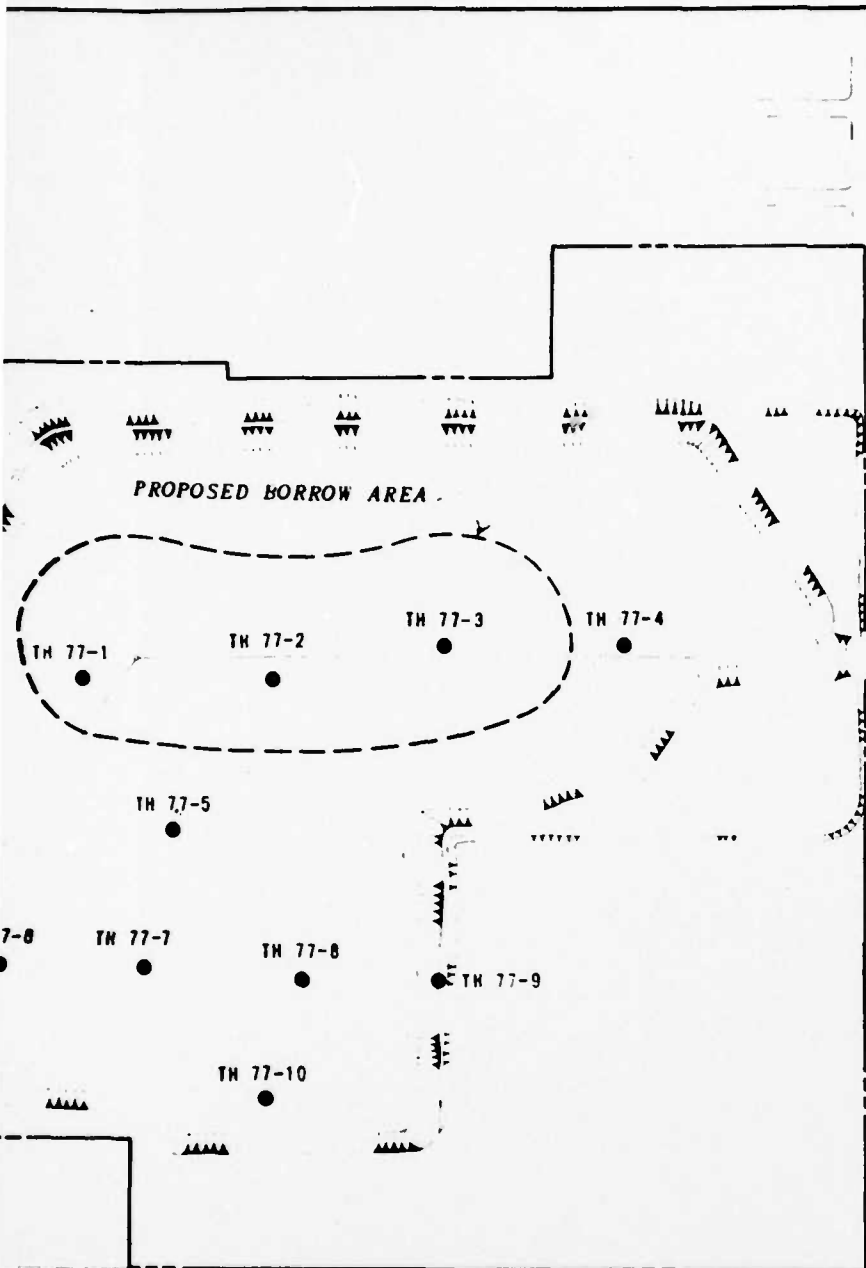

LEGEND

TH 77-1 ● LOCATION AND NUMBER OF TEST HOLE

NOTES

1. TEST HOLES WERE DRILLED DURING JUNE 1977 WITH A 16-INCH DIAMETER BUCKET TYPE POWER AUGER.
2. FOR LOGS OF TEST HOLES SEE PLATE 2.

SYMBOL	DESCRIPTION	DATE	APPROVAL
REVISIONS			
U. S. ARMY ENGINEER DISTRICT LOS ANGELES CORPS OF ENGINEERS			
DESIGNED BY:	TUCSON DIVERSION CHANNEL DETENTION BASIN PARK TEST HOLE LOCATIONS		
DRAWN BY: LHR			
CHECKED BY:			
SUBMITTED BY:	APPROVED:	TITLE TO BE PRINTED	SHEET
APPROVAL RECOMMENDED	SPEC. NO. DRAWING NO. DATE	DISTRICT FILE NO.	OF SHEETS

TH 77-3

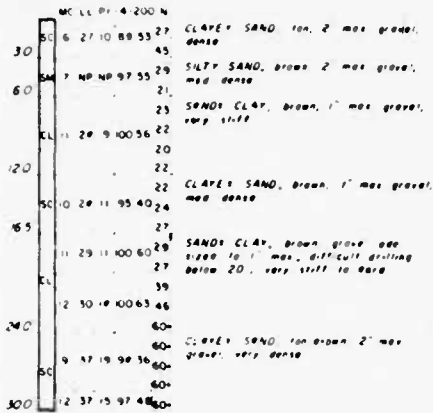

TH 77-6

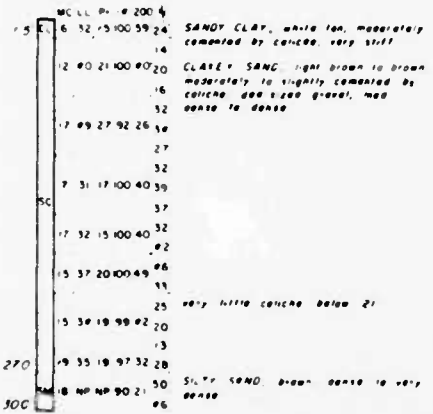

TH 77-10

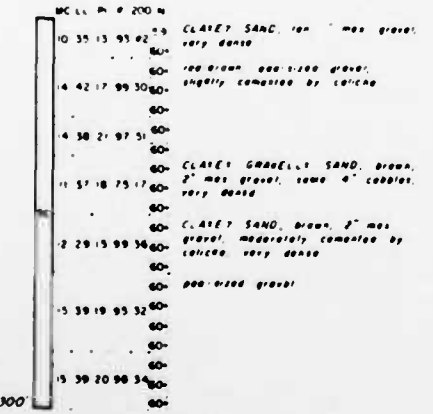

UNIFIED SOIL CLASSIFICATION SYSTEM

MAJOR DIVISIONS		GROUP SYMBOLS	TYPICAL NAMES
COARSE GRAINED SOILS More than half of material is larger than 200 sieve	GRAVELS More than half of coarse fraction is larger than 4.75 mm sieve	GW	Well graded gravel, gravel sand mixtures, little or no fines
		GP	Poorly graded gravel, gravel sand mixtures, little or no fines
		GM	Silty gravel, gravel sand mixtures
	SANDS More than half of coarse fraction is larger than 4.75 mm sieve	GC	Clayey gravel, gravel sand mixtures
		SW	Well graded sands, gravelly sands, little or no fines
		SP	Poorly graded sands, gravelly sands, little or no fines
FINE GRAINED SOILS More than half of material is smaller than 200 sieve	SANDS AND SILTS	SM	Silty sands, sand silt mixtures
		SC	Clayey sands, sand clay mixtures
		ML	Inorganic silts and very fine sands, wet flow silty or clayey fine sands, or clayey silts, with slight plasticity
	CLAYS AND CLAYEY SILTS	CL	Inorganic clays of low to medium plasticity, gravelly clays, sandy clays, silty clays, loam clays
		OL	Organic silts and organic silty clays of low plasticity
		MH	Inorganic silts, micaceous or detritaceous fine sandy or silty soils, elastic silts
Highly organic soils	CH	Inorganic clays of high plasticity, fat clays	
	OH	Organic clays of medium to high plasticity, organic silts	
		PT	Peat and other highly organic soils

NOTE: 1. Boundary Classification. Soils possessing characteristics of two groups are designated by combinations of group symbols. For example, GW-GC, well graded gravel sand mixtures with clay binder.
 2. All soil tests on this chart are U.S. Standard.
 3. The terms "silt" and "clay" are used respectively to distinguish materials exhibiting lower plasticity from those with higher plasticity. The amount of 200 sieve material is plotted at the liquid limit and plasticity index plot below the "A" line on the plasticity chart Table VI, Military Standard 8198 and a clay if the liquid limit and plasticity index plot above the "U" line on the chart.
 4. For a complete description of the Unified Soil Classification System, see Military Standard 8198 dated 20 March 1976.

LEGEND

- TH LOCATION AND NUMBER OF TEST HOLE
- MC FIELD MOISTURE CONTENT IN PERCENT OF DRY WEIGHT
- LL LIQUID LIMIT
- PI PLASTICITY INDEX LIQUID LIMIT MINUS PLASTIC LIMIT
- NP NONPLASTIC
- C PERCENT OF MATERIAL BY WEIGHT PASSING NO. 4 SIEVE
- DOB PERCENT OF MATERIAL BY WEIGHT PASSING NO. 200 SIEVE
- H NUMBER OF BLOWS OF A 140 POUND SOFTHAMMER FALLING 50 INCHES REQUIRED TO DRIVE A SAMPLING SPHERICAL POINT OUTSIDE DIAMETER OF SPHERES IS 3 INCHES INSIDE DIAMETER IS 1.5 INCHES. PROCEDURE IS CALLED STANDARD PENETRATION TEST
- W DEPTH TO WATER

TH 77-7

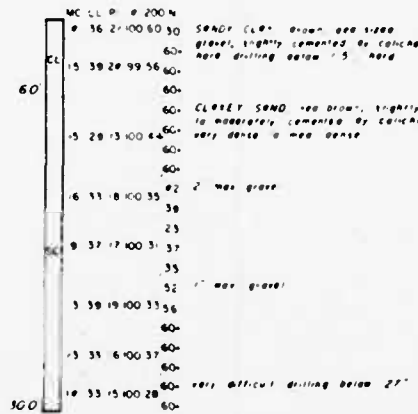

DATE	REVISIONS	DATE	APPROVAL
U.S. ARMY ENGINEER DISTRICT LOS ANGELES CORPS OF ENGINEERS			
TUSCON DIVERSION CHANNEL DETENTION BASIN PARK LOGS OF EXPLORATION			
DESIGNED BY	CHECKED BY		
DRAWN BY	APPROVED BY		
APPROVAL	DATE	APPROVAL	DATE

2

LINER COST vs SEEPAGE LOSS FOR FIVE LININGS

LEGEND:

- △ AREA = 15 ACRES
- AREA = 31 ACRES
- AREA = 46 ACRES
- AREA = 61 ACRES

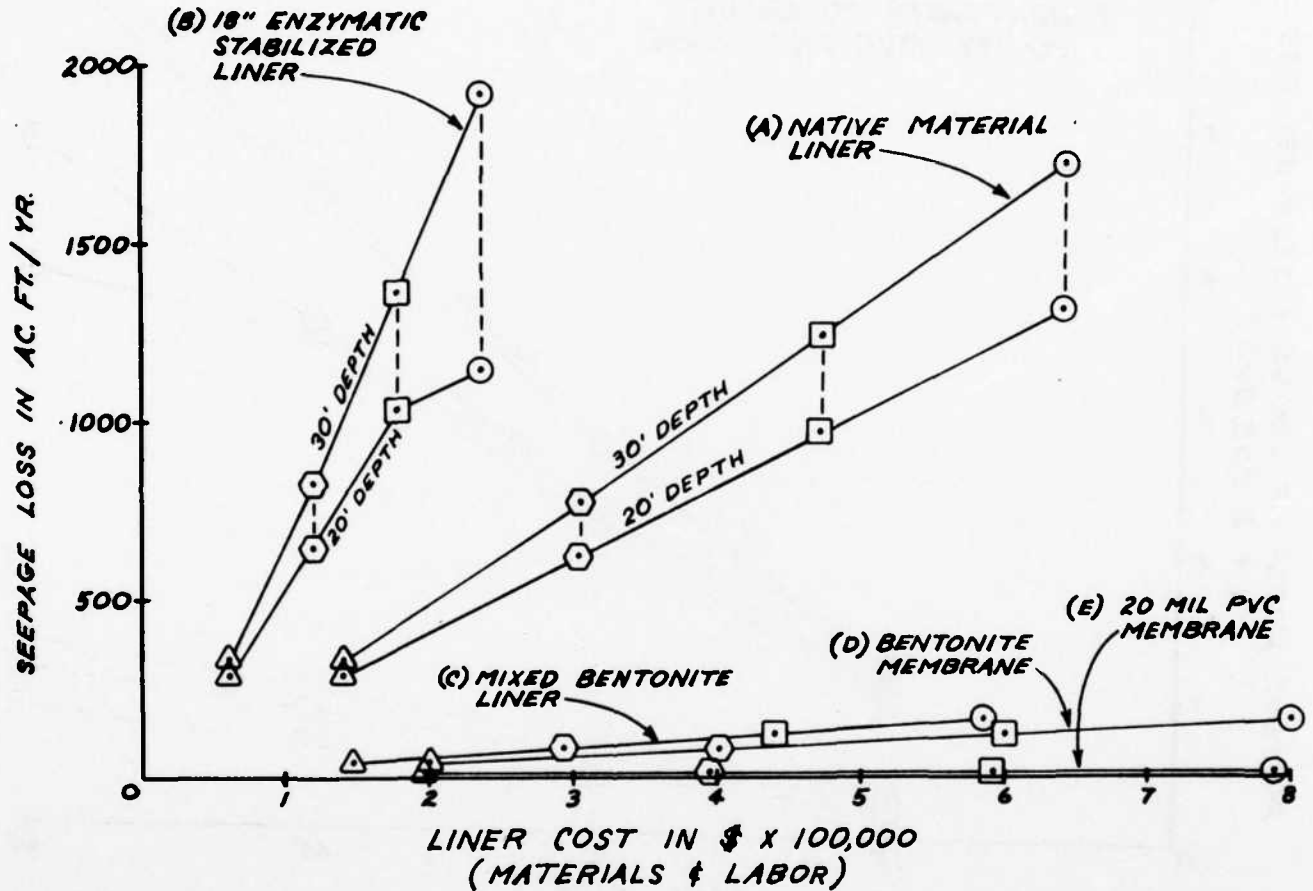

NOTES:

1. GENERAL LAKE CROSS SECTION ASSUMED TO HAVE 1:5 SIDESLOPES AND A FLAT BOTTOM 20 AND 30 FEET BELOW THE WATER SURFACE.
2. FEASIBILITY OF LININGS (B) AND (C) BASED UPON ANALYSIS BY SUPPLIER.

FIGURE 1

PRESENT WORTH OF LINING COST PLUS
SEEPAGE LOSS COST

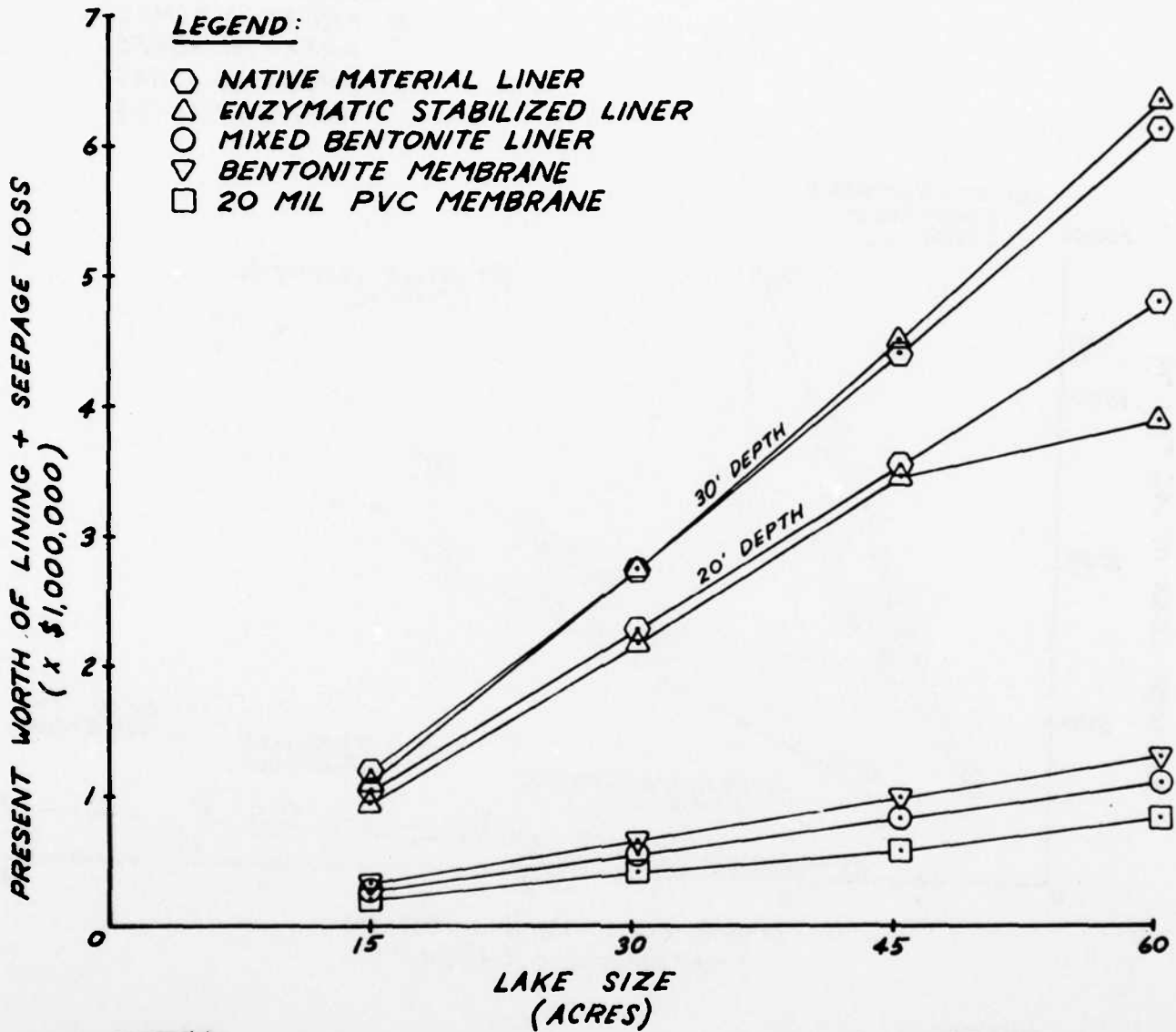

NOTES:

1. PRESENT WORTH BASED ON 25 YEAR LIFE, 6 PERCENT ANNUAL INTEREST RATE, AND WATER COST OF \$250 PER ACRE FOOT.
2. COSTS OF BENTONITE AND PVC SYSTEMS ARE THE SAME FOR 20 FOOT AND 30 FOOT DEPTHS.

FIGURE 2

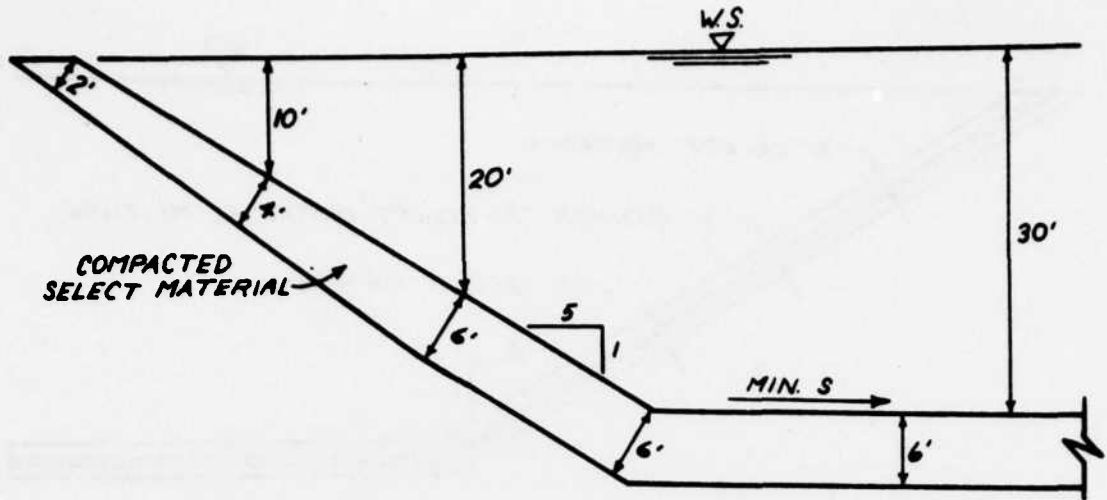

FIGURE 3: NATIVE MATERIAL LINER

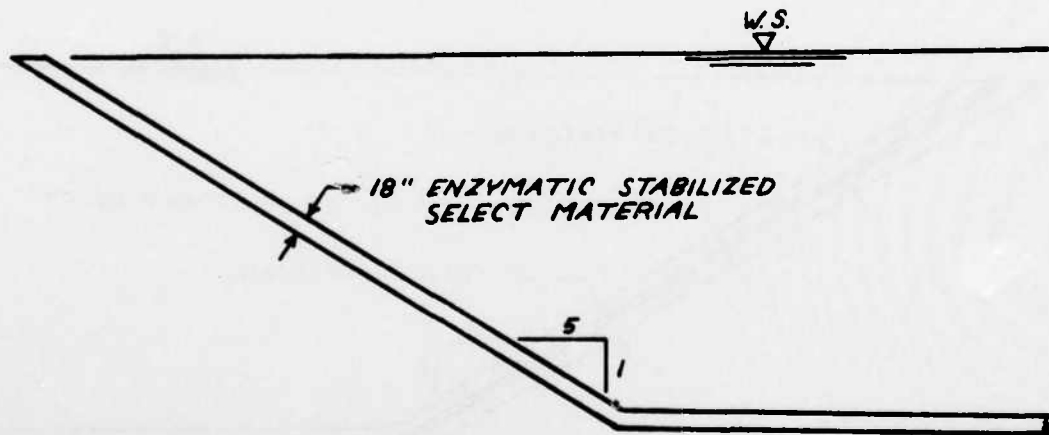

FIGURE 4: ENZYMATIC STABILIZED LINER

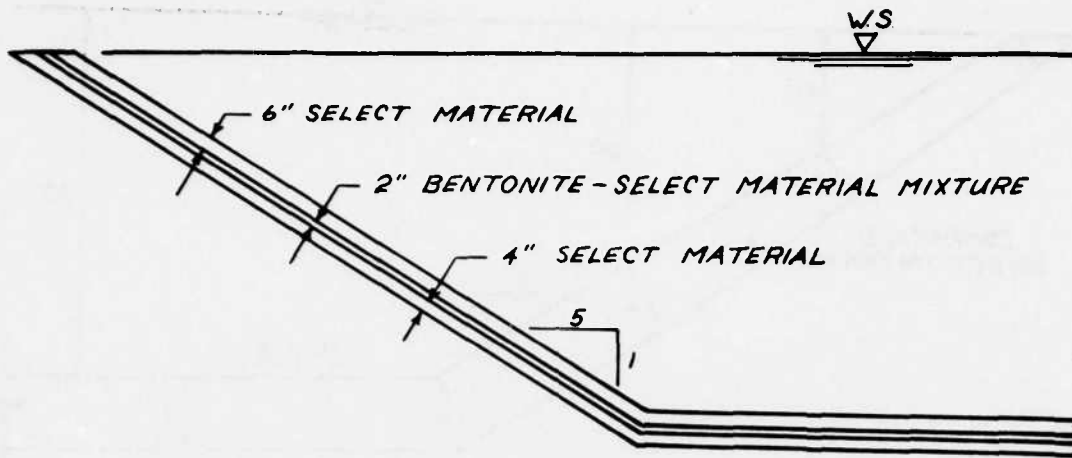

FIGURE 5: MIXED BENTONITE LINER

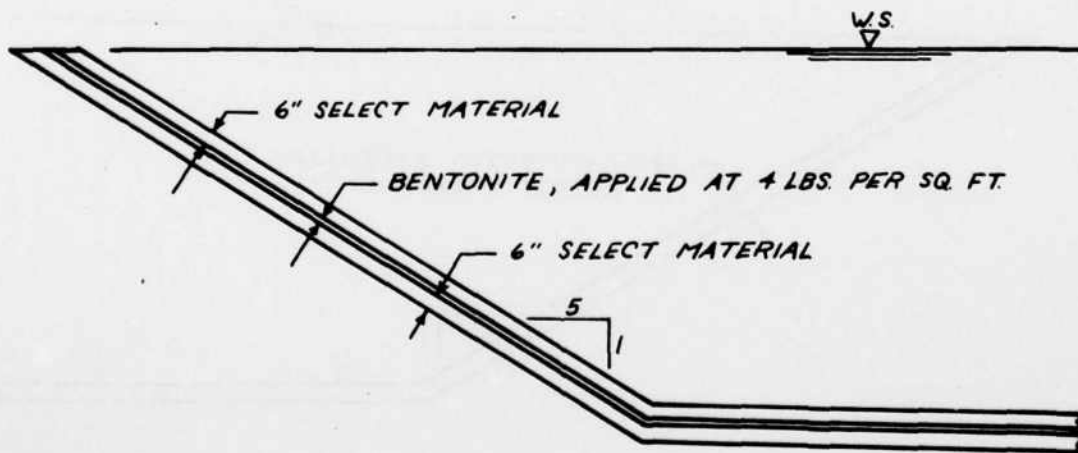

FIGURE 6: BENTONITE MEMBRANE

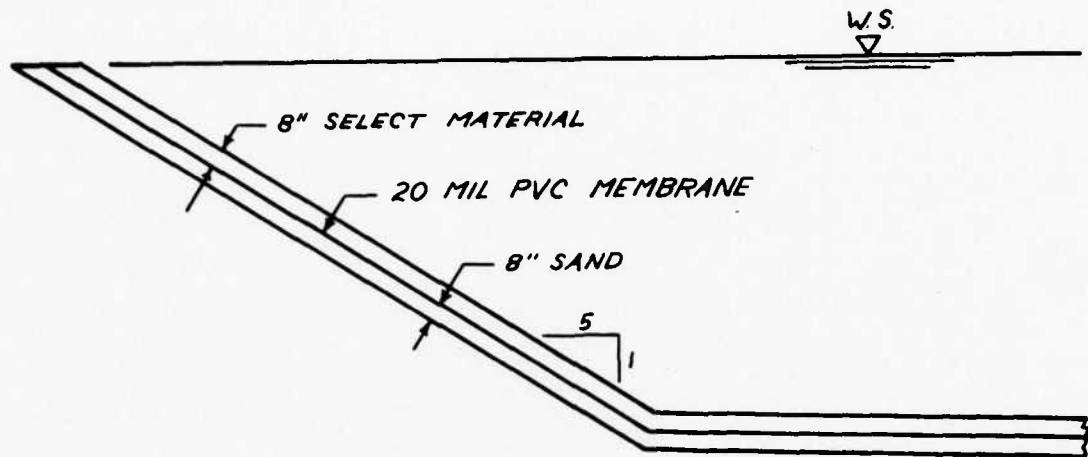

FIGURE 7: 20 MIL PVC MEMBRANE

APPENDIX D
WATER QUALITY STANDARDS
FOR RECREATION

A. WATER QUALITY STANDARDS FOR RECREATION

The physical, biological, and chemical properties of the effluent from the Randolph Wastewater Treatment Plant are shown in table D-1. The type of effluent treatment that is needed for these properties is compared to the water quality requirements for recreation use established by the Arizona Department of Health Services. These water quality standards are shown in tables D-2 and D-3.

Those waste water reuse guidelines were based on (1) "Rules and Regulations for Reclaimed Wastes," Article 6, Part 4, by the Arizona Department of Health, in which the minimum level of treatment specified is "secondary treatment," and (2) specific Federal criteria for what constitutes secondary treatment. It should be mentioned that the EPA guidelines are more stringent than those of the State, 30 mg/l BOD compared with 35 mg/l BOD, and 30 mg/l total SS compared with 35 mg/l total SS for the state. These two values have been incorporated in table D-2, the values in parentheses reflect the anticipated change in the state guidelines to match the existing, more rigorous Federal guidelines.

An analysis of these three tables reveals that if the level of suspended solids and nutrients were reduced, the effluent would meet recreation water quality requirements. The treatment process that could be used is discussed in Chapter 2, A.5 and Chapter 3,C.

Table D-1. Quality of Effluent.

Parameter	Randolph Effluent (Average)		
	High	Low	Median
Fecal Coliform (N/100 m.l.)		279	
5 Day BOD (mg/l)		15	
Dissolved Oxygen (mg/l)		1.8	
Turbidity (Jackson Turbidity Units)		30	
pH		7.4	
Suspended Solids (mg/l)		14	
Settleable Solids (mg/l)		6.0	
Chlorine Residual (mg/l)		0.9	
Total Dissolved Solids (mg/l)		486	
Phosphates (as PO ₄)(mg/l)		18.2	
Iron (mg/l)		0.65	
Nickel (mg/l)		0.06	
Cadmium (mg/l)		0.008	
Chromium (mg/l)		0.03	
Copper (mg/l)		0.36	
Zinc (mg/l)		0.39	
Lead (mg/l)		0.04	
Manganese (mg/l)		0.05	
<u>Nitrogen Species</u>			
Ammonium Nitrogen (as N)(mg/l)	45.3	7.1	20.2
Nitrate Nitrogen (as N)(mg/l)	2.6	0.14	1.1
Nitrite Nitrogen (as N)(mg/l)	5.8	0.02	1.5

Table D-2. Effluent Quality Requirements for Various Uses.

Effluent Quality Requirements ^a							
Use	BOD ₅	Total SS	Total Dissolved Solids	Toxic Substance	Total Phosphorus	Total Nitrogen	Bacteriological
Irrigation	35	35	709	b	c	c	c
Fibrous or forage crops not intended for human consumption	(30)	(30)					(1000) c
Orchard crops-no direct application of water to fruit of foliage	35	35	709	b	c	c	(1000) c
Food crops-product subjected to physical or chemical processing sufficient to destroy pathogenic organisms	(30)	(30)					
Orchard crops-direct application to fruit or foliage	35	35	709	b	c	c	1000
Food crops that may be consumed in their raw state	(30)	(30)					
Golf courses, cemeteries and similar areas	10	10	709	b	c	c	200
School grounds, playgrounds, etc. where children are expected to play	35	35	709	b	c	c	1000
	(30)	(30)					
	10	10	709	b	c	c	200

For footnotes see end of table.

Table D-2. Effluent Quality Requirements for Various Uses. (Continued)

Use	Effluent Quality Requirements ^a							Bacterio-logical
	BOD ₅	Total SS	Total Dissolved Solids	Toxic Sub-stance	Total Phos-phorus	Total Nitrogen		
Watering Farm animals other than producing dairy animals Producing dairy animals	35 (30)	35 (30)	709	b	c	c	c	c (1000) 1000
	35 (30)	35 (30)	709	b	c	c	c	
Recreational Impoundments Esthetic enjoyment or involving only secondary contact Primary contact recreation	35	35			c		1000	
	(10)	(10)			(.15)		(200)	
	10 (5)	10 (5)	709	b	0.5	c	(2.3)	
Groundwater Recharge Ponding on surface	35 (30)	35 (30)	409	b	c	c	1000	
	10 (5)	10 (5)	409	b	0.5	10	200	

Note: Figures in parentheses are anticipated future standards. Concentrations expressed in terms of mg/l. Bacteriological figures expressed in terms of fecal coliform group density (count) per 100 ml.

- a. Based on "Effluent Parameters for Reclaimed Wastes," by Arizona Department of Health, April 1972.
- b. Not to exceed United States Health Service drinking water standards.
- c. No limit on concentration.

Table D-3. Specific Standards for Protection Uses.

Parameter	Protected Uses					
	Domestic Water Source	Recreation		Aquatic and Wildlife	Agricultural	
		Full Body	Partial Body		Irrigation	Livestock Watering
Fecal Coliform ^a (Units/100 ml)	1000	200	1000	1000	1000	1000
1. Geometric Mean (5 Sample Minimum)	2000	400	2000	2000	2000	2000
2. 10% of Samples for 30-Day Period will not Exceed	4000	800	4000	4000	4000	4000
3. Single Sample will not Exceed	NS	8.6	8.6	9.0	9.0	9.0
pH ^b	NS	6.5	6.5	6.5	6.5	6.5
1. Maximum	NS	0.5	0.5	0.5	NS	NS
2. Minimum						
3. Maximum Charge due to Waste Discharge						
Trace Substances ^b (Maximum mg/l)						
Arsenic (AS As)	0.050 D	0.050 D	(c)	0.050 D	2.000 T	0.200 T
Barium (AS Ba)	1.000 D	1.000 D	(c)	NS	NS	NS
Boron (AS B)	NS	NS	(c)	NS	1.000 T	NS
Cadmium (AS Cd)	0.010 T	0.010 T	(c)	0.010 D ^d	0.050 T	0.050 T
Chromium (AS Cr, Hexavalent and Trivalent)	0.050 D	0.050 D	(c)	0.050 D	1.000 T	1.000 T
Copper (AS Cu)	NS	NS	(c)	0.050 D	5.000 T	0.500 T
Lead (AS Pb)	0.050 D	0.050 D	(c)	Less than 0.050 D ^e	10,000 T	0.100 T
Manganese (AS Mn)	NS	NS	(c)	NS	10,000 T	NS
Mercury (AS Hg)	0.002 T	0.002 T	(c)	Less than 0.002 T ^e	^c	0.010 T
Selenium (AS Se)	0.010 D	0.010 D	(c)	^c	0.020 T	0.050 T
Silver (AS Ag)	0.050 D	0.050 D	(c)	0.050 D	NS	NS
Zinc (AS Zn)	NS	NS	(c)	0.500 D	10,000 T	NS
Ammonia (AS un-ionized NH ₃)	NS	NS	NS	0.020	NS	NS
Cyanide (AS Cyanide ion and Complexes)	0.200	0.200	(c)	Less than 0.020 ^e	NS	0.200
Phenolics	0.005	0.005	(c)	0.005	NS	0.005
Sulfides (Total)	NS	NS	NS	Less than 0.100 ^e	NS	NS

For footnotes see end of table.

AD-A139 159

MASTER PLAN TUCSON DIVERSION CHANNEL RECREATION
DEVELOPMENT PROGRAM GILA RIVER AND TRIBUTARIES ARIZONA
AND NEW MEXICO(U) ARMY ENGINEER DISTRICT LOS ANGELES CA
OCT 81

2/2

UNCLASSIFIED

F/G 13/2

NL

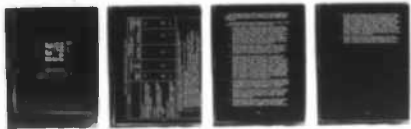

END
DATE
FILMED
4-84
DTIC

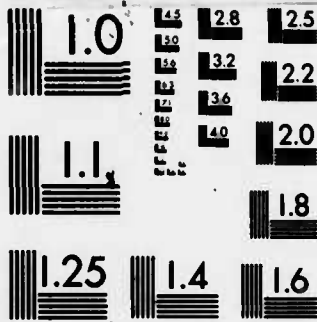

MICROCOPY RESOLUTION TEST CHART
NATIONAL BUREAU OF STANDARDS-1963-A

Table D-3. Specific Standards for Protection Uses. (Continued)

Parameter	Protected Uses				
	Domestic Water Source	Recreation Full and Partial Body	Aquatic and Wildlife		Agricultural Irrigation and Livestock Watering
			Warm Water Fishery Habitat	Cold Water Fishery Habitat	
Temperature ^{b, f} Heat added by a discharge or combination of discharges will not raise the natural ambient water temperature more than _____ degrees Celsius.	NS	3	3	1	NS
Turbidity ^{b, f} A discharge or combination of discharges will not cause the turbidity to exceed _____ Jackson turbidity units in: Streams Lakes	NS NS	50 25	50 25	10 10	NS NS
Dissolved Oxygen ^h A discharge or combination of discharges will not lower the dissolved oxygen concentration to less than _____ mg/l.	NS	6	6	6	NS

Note: Abbreviations used; NS, no standard; T, total trace substances; and D, dissolved fraction. Source of information used in table, "Water Quality Standards for Surface Waters, Arizona Water Quality Control Council, June 8, 1979.

a. For limits applicable to direct waste water reuse, see A.C.R.R. R9-20-400s.
b. Applies also to effluent dominated streams.
c. Too little is known about adverse effects for this use to select a number adequately.
d. For cold water fishery habitat, maximum cadmium concentration is 0.001 mg/l.
e. The maximum concentration for this use is set at the current minimum level of detection.
f. Temperature standard not applicable to impoundments owned by a firm or individual for the express purpose of providing or receiving heat wastes.
g. Standards are applicable to turbidity caused by activities including, but not limited to, construction, mining, logging, agriculture, and other similar nonpoint sources.
h. Dissolved oxygen.

The residential area the Randolph plant serves is well established and not likely to change radically soon. Therefore, no major changes in the quality of the effluent during the life of the waste water treatment plant are expected.

The following describes some of the parameters given in table D-1 that are used to evaluate the suitability of effluent for reuse:

- Dissolved solids is a general term used to describe the mineral content of water. Total dissolved solids (TDS) consist primarily of sodium, potassium, calcium and magnesium cations and carbonate, chloride, sulfate and nitrate anions. Other constituents usually present in small amounts are silver, arsenic, iron, chromium, cadmium, lead, mercury, copper, zinc, etc. Generally speaking, water with a TDS of less than 1000 mg/l is considered fresh; a TDS from 1000 to 10,000 mg/l is considered brackish; a TDS from 10,000 to 25,000 mg/l is considered saline; and a TDS greater than 25,000 mg/l is considered seawater.
- Biological Oxygen Demand (BOD₅) is the most widely used parameter in describing organic pollution, applied to both waste water and surface waters. This parameter is a determination of the relative amount of dissolved oxygen that is used by microorganisms in the biochemical oxidation of organic matter.
- Suspended solids (SS) generally describes the organic and inorganic particles that are not dissolved. Approximately 75 percent of suspended solids are organic in nature, generated by both plant and animal life. Organic compounds consist of combinations of carbon, hydrogen and oxygen. Other elements such as sulfur, phosphorus and iron also might be present. Suspended solids also encompass an ever-increasing amount of synthetically produced organics that range from very simple to extremely complex in structure. These synthetically produced organics include substances used as surfactants, phenols, and agricultural pesticides. The presence of these substances has complicated waste water treatment in recent years because many of them cannot be, or are very slowly, decomposed biologically.
- The fecal coliform count is a measurement that generally indicates microbiological content including viruses and pathogenic organism. Fecal bacteria of the coliform group are primary indicators of fecal contamination and are of sanitary significance. Fecal coliform bacteria is often used to monitor recreation water quality.
- Phosphorus in its elemental form can be toxic to man and accumulates in much of the same way as mercury. Phosphorus as phosphate is a nutrient that is essential for plant life. Phosphate stimulates growth of aquatic plants such as algae, which can result in eutrophication.
- Nitrogen comes in several forms - two gases, molecular nitrogen and nitrous oxide, and in five nongaseous forms of combined nitrogen, ammonia nitrite and nitrate, and amino and amide groups, each of which is a significant part of the nitrogen cycle.

- Ammonia, organic nitrogen, nitrates, and nitrites are the forms of nitrogen that are significantly present in waste water. Organic nitrogen and ammonia, both of which are discharged in human wastes, are in general, the initial forms of nitrogen present in sewage. As time progresses, bacterial action converts the organic nitrogen into ammonia, and then, under aerobic conditions, the ammonia is oxidized to nitrites and nitrates. Under anaerobic conditions nitrates are reduced to nitrites. Nitrites under anaerobic conditions are further reduced to nitrogen gas, or to a lesser degree, to ammonia. The relative proportions of these forms of nitrogen, therefore, are indicators of the freshness of waste water and the quality of treated effluent.
- Organic, ammonia and nitrite nitrogen present in waste water treatment plant effluent exert an oxygen demand in the receiving waters. In addition, the nitrate form of nitrogen serves as a nutrient for aquatic plants and promotes eutrophication of lakes.

