

AD-A139 499

THE EFFECT OF DISCRETE SPANWISE REGIONS OF BLEED ON  
PSEUDO-TWO DIMENSIONAL (U) AERONAUTICAL RESEARCH LABS  
MELBOURNE (AUSTRALIA) N POLLOCK JUL 83

1/1

UNCLASSIFIED

ARL/AERO NOTE-418

F/G 20/4

NL

END
DATE
FILMED
5 84
DTIC

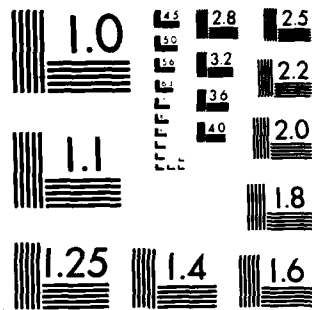

MICROCOPY RESOLUTION TEST CHART  
NATIONAL BUREAU OF STANDARDS-1963-A

12



AD A139499

DEPARTMENT OF DEFENCE  
DEFENCE SCIENCE AND TECHNOLOGY ORGANISATION  
AERONAUTICAL RESEARCH LABORATORIES

MELBOURNE, VICTORIA

AERODYNAMICS NOTE 418

THE EFFECT OF DISCRETE SPANWISE REGIONS  
OF BLEED ON PSEUDO-TWO DIMENSIONAL BASE  
FLOW AT TRANSONIC SPEEDS

by  
N. POLLOCK

DTIC  
ELICITE  
MAR 30 1984  
A

Approved for Public Release

THE UNITED STATES NATIONAL  
TECHNICAL INFORMATION SERVICE  
IS AUTHORIZED TO  
REPRODUCE AND SELL THIS REPORT

© COMMONWEALTH OF AUSTRALIA 1983

COPY No

JULY 1983

DTIC FILE COPY

84 03 29 10Z

DEPARTMENT OF DEFENCE  
DEFENCE SCIENCE AND TECHNOLOGY ORGANISATION  
AERONAUTICAL RESEARCH LABORATORIES

AERODYNAMICS NOTE 418

**THE EFFECT OF DISCRETE SPANWISE REGIONS  
OF BLEED ON PSEUDO-TWO DIMENSIONAL BASE  
FLOW AT TRANSONIC SPEEDS**

by

N. POLLOCK

*SUMMARY*

↳ A preliminary experimental study of a new type of pseudo-two-dimensional bluff base consisting of a series of rectangular prismatic protrusions spaced along the span with base bleed into the regions between the protrusions is presented.

A base geometry was derived which had less drag at subsonic and transonic speeds than the best reported non-bleed arrangement for bleed mass flow coefficients (based on the mass flux swept by the model frontal area) in the range 0.02 to 0.04. A simple two-dimensional bleed arrangement requires a bleed coefficient greater than 0.08 to achieve the same subsonic base drag. ↪



---

POSTAL ADDRESS: Director, Aeronautical Research Laboratories,  
Box 4331, P.O., Melbourne, Victoria, 3001, Australia



## NOTATION

<i>b</i>	Spanwise length of protruding block
<i>C<sub>p</sub></i>	Pressure coefficient = $(P - P_0)/(\gamma P_0 M_0^2/2)$
(CP SPACE)	<i>C<sub>p</sub></i> , with <i>P</i> = static pressure in plane of trailing edge midway between blocks
(CP BLOCK)	<i>C<sub>p</sub></i> , with <i>P</i> = average pressure acting on downstream face of block
<i>C<sub>p<sub>b</sub></sub></i> (CP TOTAL)	<i>C<sub>p</sub></i> , with <i>P</i> = average pressure acting over entire base area = $((\text{CP SPACE}) \times S + (\text{CP BLOCK}) \times b)/(b + S)$
<i>C<sub>q</sub></i> (CQ)	Bleed mass flow coefficient = $Q/U_0 \rho_0 h$
(CQ LOCAL)	Bleed mass flow coefficient for space between blocks = $(C_q \times (b + S))/S$
<i>h</i>	Model base height
<i>M<sub>0</sub></i> (MACH NO.)	Free stream Mach number
<i>P<sub>0</sub></i>	Free stream static pressure
<i>Q</i>	Average bleed mass flow per unit span
<i>Re</i> (REYN. NO.)	Reynolds number based on <i>h</i>
<i>S</i>	Spanwise space between blocks
<i>U<sub>0</sub></i>	Free stream velocity
$\gamma$	Ratio of specific heats (1.4)
$\rho_0$	Free stream density
$\theta$	Boundary layer momentum thickness

*Note:* Names in brackets are headings used in tables 1 to 6.

## 1. INTRODUCTION

It has been pointed out by a number of authors<sup>1,2,3</sup> that aerofoils with blunt trailing edges have many potential advantages at transonic speed. A number of the so called "supercritical" aerofoil sections<sup>4,5</sup> incorporate a small amount of trailing edge bluntness. At the present time the more extensive use of blunt trailing edges is prevented by the occurrence of a significant "base drag" penalty due to the low pressure which acts over the base area. Any method of reducing two-dimensional subsonic and transonic base drag will permit the more extensive use of blunt trailing edges with their attendant aerodynamic advantages<sup>1,2,3</sup>.

Many geometric modifications to blunt trailing edges aimed at reducing base drag have been investigated.<sup>6</sup> Overall the most promising designs appear to be the serrated or segmented trailing edges developed independently by Tanner<sup>7</sup> and the present author.<sup>8</sup> These base geometries give drag reductions of about 60% over a simple blunt base. Greater drag reductions have been obtained<sup>6</sup> using thick splitter plates or wedges attached to the base, but these arrangements are not attractive for transonic aerofoils since they would exhibit many of the problems associated with conventional sharp trailing edges.

An alternative approach to the reduction of two-dimensional base drag is the use of base bleed. Tests at low,<sup>9,10</sup> compressible subsonic and transonic<sup>11,12</sup> and supersonic<sup>13-17</sup> speeds have shown that bleeding low velocity air into the base region produces a marked reduction in drag. For Mach numbers up to 1.0 a bleed mass flow coefficient  $C_q$  of about 0.07 is required to produce a higher base pressure coefficient than the best non-bleed base type.<sup>11</sup> For Mach numbers above 1.0 only about half this bleed flow is required to give superior results to the best non-bleed base. Higher bleed mass flows produce even greater base pressure increases and for a  $C_q$  of 0.10 a base pressure about 30% higher than the best non-bleed configuration can be obtained throughout the subsonic speed range.<sup>11</sup>

The use of base bleed poses two significant problems which together severely restrict the range of practical applications of this technique of drag reduction. The first problem is the size of the ducting which must be accommodated in the wing section to supply the bleed air. To supply a  $C_q$  of 0.1 at transonic speeds while retaining a reasonable duct velocity would result in a large proportion of the volume of the wing being occupied by bleed air ducting. This would compromise the structural design and for an aircraft would also restrict the fuel volume which could be stored. The second problem relates to the momentum drag of the bleed air. If the bleed mass flow is derived from the free stream there will be a drag force produced due to the reduction in the momentum of this flow. For small bleed quantities this momentum dissipation will be virtually complete and the effective base pressure increment will be<sup>9,18</sup>  $\Delta C_{p_b} \approx -2 C_q$ . This drag increment could be reduced if the bleed mass could be obtained from a boundary layer bleed or eliminated if the bleed was not derived from the free stream. Bleed sources not derived from the free stream include on-board gas generation for an aircraft and ambient air bleed from outside the engine for a compressor blade.

Since the isolated base protrusions of the segmented trailing edge geometries<sup>7,8</sup> have a very low drag and base bleed can produce low drag,<sup>9-17</sup> albeit for inconveniently large bleed quantities, it appeared that the two techniques could be combined to produce a base with low drag and a reasonably small bleed requirement. The configuration chosen for study consisted of a series of rectangular prisms protruding downstream from the base with bleed introduced in the spaces between the blocks (Fig. 1). The preliminary investigation reported here was intended to establish guidelines for the optimum geometry of such a base design and to obtain an indication of the drag reductions obtainable. The tests described were carried out in the Transonic Wind Tunnel during September and October 1982.

## 2. EXPERIMENTAL DETAILS

### 2.1 Model

The model (Fig. 1) was of hollow construction with the upper and lower portions separated by a number of spacers which incorporated the downstream protruding blocks. The number of spacers used and hence the  $b/S$  ratio could be varied. A series of inlet choke plates which produced slit intakes of various widths at the model leading edge were used to regulate the mass flow through the channels between the spacers. The 1.6 mm diameter wire located just downstream from the choke plate (Fig. 1) was used to prevent the bleed flow from forming a wall jet attached to one side of the duct through the model. The bleed mass flow was introduced into the base region over almost the entire area of the space between the blocks. This was done because two-dimensional subsonic<sup>9</sup> and supersonic<sup>13</sup> tests have shown that best results are obtained when the bleed flow is introduced at as low a velocity as possible.

The bleed mass flow was measured with a six tube pitot rake and a duct wall static tapping located midway between the midspan spacer and one of the adjacent spacers. The effective base pressure acting on the space between the blocks was measured using a 1.6 mm diameter static probe supported from downstream. The static probe, which was located midway between the midspan block and one of its neighbours, protruded into the model cavity with its pressure orifices in the plane of the base. The effective base pressure acting on the base of the blocks was taken as the average of 8 pressure tappings on the midspan block which were arranged to be representative of the pressures acting at the centres of 32 equal area rectangular elements covering the block base (Fig. 2).

The forward 31% of the model was of approximately semi-elliptic form and the remainder of the chord was parallel sided. The model thickness to chord ratio (not including the blocks) was 12.5% and the bleed aperture to base height ratio was 93%. The model completely spanned the width of the tunnel and was supported by integral end tongues which passed through slots in the tunnel sidewalls. Boundary layer trips consisting of spanwise bands of 0.15 mm carborundum particles attached with a thin (0.03 mm) layer of lacquer were used on both surfaces of the model. The bands were located 10 mm aft of the leading edge and were 2 mm wide, with a particle coverage of 20%.

### 2.2 Wind Tunnel

The tests were carried out in the ARL transonic wind tunnel (Fig. 3), which has a test section 813 mm high and 533 mm wide. Solid sidewalls and longitudinally slotted top and bottom walls with an open area ratio of 16.5% at the model location were fitted. Mach number and dynamic pressure were derived from measurements of the pressure in the plenum chamber surrounding the test section and in the contraction entry assuming these to be the static and total pressures of the test section flow respectively.

The model blockage ratio (model frontal area/test section area) was 1.9%. Due to the difficulty in predicting tunnel wall interference for models of this type no corrections were applied to the experimental data. The results of Ref. 19 suggest that the blockage correction to Mach number should be less than  $\Delta M = 0.01$  at  $M_0 = 0.80$ .

### 2.3 Test Program

The model was tested at zero incidence and Mach numbers of 0.50, 0.60, 0.70, 0.80, 0.85, 0.875, 0.90, 0.925, 0.95, 0.975, 1.00, 1.10, 1.20, 1.30 and 1.35. The tests were conducted with a single block at midspan, taken to represent  $b/S = 0$ ; with 5 blocks equally spaced giving  $b/S = 1.20$ ; with 7 blocks giving  $b/S = 2.67$  and with 9 blocks giving  $b/S = 10.16$ . Nine different inlet slot widths were used to cover the range of local bleed mass flow coefficients from 0 to about 0.15.

The tunnel operating pressure was varied during the tests to achieve a reasonable compromise between holding the Reynolds number constant and utilizing the maximum Reynolds number available at each Mach number. The variation of test Reynolds number with Mach number is shown in Fig. 4. At Mach numbers where the tunnel pressure was altered ( $M_0 = 0.50, 0.70, 0.90$  and  $1.10$ ) test points were taken at the higher and lower values. At a Mach number

of 0.6, for one base arrangement, the effect of varying the Reynolds number over the range  $1.8 \times 10^4 < Re < 1.8 \times 10^5$  was investigated.

Earlier tests<sup>11</sup> on an identical model without the base extensions had shown that the external boundary layers approaching the base were turbulent under all test conditions and that their thickness was not significantly affected by Mach number or bleed mass flow. A pitot traverse of the boundary layer at the base was carried out at  $M_0 = 0.50$ ,  $Cq = 0.025$  and  $b/S = 0$ . The resulting velocity distribution (Fig. 5) showed a turbulent profile with a thickness of 2.1 mm and a momentum thickness of 0.22 mm.

#### 2.4 Data Reduction

A preliminary calibration of the static probe used to measure the base pressure between the blocks showed it to be free of measurable error (error  $< 0.1\%$  of reading) under the conditions it would experience in the base flow. The static probe pressure was therefore used directly in the calculation of pressure coefficient. As discussed in section 2.1 the base pressure acting on the downstream face of the protruding blocks was obtained from the average of eight pressure tapings appropriately located on the midspan block.

The bleed mass flow was calculated as follows: The local Mach number at each of the six pitot tubes (Fig. 1) was calculated using the static pressure from the duct wall tapping and the relevant pitot pressure. The local sonic velocity and density and hence the local mass flux at each pitot location was calculated assuming the total temperature of the bleed flow to be equal to the free stream stagnation value. The total mass flow was obtained by simply summing the local values. The alternative approach of using a least squares quadratic best fit to the six local mass flux values and then integrating yielded values of mass flow which agreed within the experimental scatter with the simple summed values.

#### 2.5 Note on Experiment Design

The preferred method of carrying out a test of this nature would be to introduce the bleed air into the model from an external source and then distribute it appropriately with internal ducting. This would facilitate the accurate measurement of total bleed mass flow and permit the adjustment of the bleed distribution to make it even across the span. Unfortunately the expense and complexity of a model of this type could not be justified for preliminary feasibility tests of the type described here. The method of deriving the bleed air from a leading edge inlet has the advantage of simplicity but the disadvantages of the outer flow around the model varying with the bleed quantity and the difficulty of ensuring spanwise bleed uniformity. It is considered that spanwise bleed variations are the major factor contributing to the scatter evident in some of the results. Despite these problems the experimental method used is thought to be sufficiently accurate for an assessment of the potential performance of this new base type and to give some indication of an optimum arrangement.

### 3. RESULTS AND DISCUSSION

A complete listing of the experimental results is presented in tables 1 to 6. The results of the Reynolds number check runs are presented in Fig. 6. It can be seen that at least for these conditions ( $M_0 = 0.6$ ,  $b/S = 1.20$ ,  $Cq = 0.01$  and  $0.08$ ) the base pressure coefficient is nearly independent of Reynolds number, with only a very weak tendency for  $C_p$  to become more negative as  $Re$  increases. The evidence from the  $M_0 = 0.50, 0.70, 0.90$  and  $1.10$  tests, where data is available at two relatively close values of  $Re$ , is that the insensitivity to  $Re$  extends to all values of  $M_0$ ,  $Cq$  and  $b/S$ .

In Figs. 7 to 21 the mean base pressure coefficient is plotted against the bleed mass flow coefficient for all test values of  $b/S$  and Mach numbers. The two-dimensional bleed results of Ref. 11 are also plotted in these figures. In general the present  $b/S = 0$  results are in satisfactory agreement with the results from Ref. 11, but where there is a significant difference more weight is given to the Ref 11 results because of their closer approach to true two-dimensional ( $b/S = 0$ ) conditions. From Figs. 7 to 21 it can be seen that for all Mach numbers up to 1.0 the  $b/S = 1.20$ ,

2.67 and 10.16 bases have a less negative  $C_p$  (less drag) than the  $b/S = 0$  base for all values of  $C_q$ . At supersonic speeds the situation is reversed and the two-dimensional bleed base ( $b/S = 0$ ) is superior to the others over the majority of the  $C_q$  range.

In Figs. 22 to 25 the smoothed curves from Figs. 7 to 21 are cross plotted to give base pressure coefficient as a function of Mach number and bleed coefficient for the  $b/S = 0, 1.20, 2.67$  and  $10.16$  bases. In Figs. 26 to 28 the data in Figs. 22 to 25 is replotted so the three base types can be compared at bleed coefficient values of 0, 0.02 and 0.04. On these three Figures the variation of base pressure coefficient with Mach number for the best reported non-bleed arrangement<sup>9</sup> is also plotted for comparison. For zero bleed flow (Fig. 26) the  $b/S = 1.20, 2.67$  and  $10.16$  bases have more negative base pressure coefficients than the non bleed base of Ref. 8 at most Mach numbers. This is not surprising since the four base types are of similar geometry except that the non-bleed base has splitter plates between the blocks rather than the open cavity of the present configurations. It is known<sup>20</sup> that a base cavity without bleed has a base pressure intermediate between that of a plain blunt base and a blunt base with splitter plate. On the basis of the optical flow visualization photographs presented in Ref. 11 it appears probable that the marked dip in drag near  $M_0 = 0.90$  is associated with the terminal shock wave interacting with the near wake downstream of the cavities. For a bleed coefficient of 0.02 (Fig. 27) the  $b/S = 2.67$  base has lower drag than the best non-bleed base in the range  $0.50 < M_0 < 1.00$  while at supersonic speeds the  $b/S = 0$  base drag drops to the best non-bleed value. For a bleed coefficient of 0.04 (Fig. 28) the  $b/S = 1.20$  and  $2.67$  bases have similar drag and they are both superior to the best non-bleed base in the range  $0.50 < M_0 < 1.00$ . At supersonic speeds the  $b/S = 0$  base has less drag than the best non-bleed base.

It should be noted that if the bleed mass flow was derived from the free stream the effective base pressure increment due to the reduction in bleed flow momentum<sup>9,18</sup> would approach  $-2 C_q$ . This increment would be sufficient to negate most of the apparent drag advantage of the present bleed type base over the earlier non-bleed base. The new base geometry studied here could be used advantageously on subsonic configurations where a source of low energy air from a boundary layer bleed was available. Since many current aircraft have boundary layer removal ducts associated with the engine intakes this requirement for low energy air may not be a significant problem. It may even be possible to design a configuration which combines the beneficial effects of boundary layer suction and base bleed by simply providing the necessary ducting.

#### 4. CONCLUSION

A preliminary experimental study has been carried out on a new type of pseudo-two-dimensional bluff base consisting of a series of isolated rectangular prismatic protrusions spaced along the span with base bleed into the regions between the protrusions. The aim of this work was to derive a new type of base geometry for use on blunt trailing edge aerofoils which combined low base drag with modest bleed requirements.

The investigation identified a design which had less drag at subsonic speeds than the best reported non-bleed design for a bleed mass flow coefficient in the range 0.02 to 0.04. This new design could have practical applications where a suitable source of low energy bleed air was available from, for example, an engine inlet boundary layer diverter. At supersonic speeds the new base was inferior to a simple two dimensional bleed and to earlier non-bleed geometries.

The bases tested had protruding blocks of height equal to the base height, streamwise length equal to  $2 \times$  base height and spanwise length equal to  $3.3 \times$  base height, these dimensions being selected on the basis of earlier non-bleed base developments. During the test the ratio of spanwise block length to space between blocks was varied. On the basis of the limited range of values investigated the optimum ratio is thought to be between 1.2 and 2.7.

## REFERENCES

1. Pearcey, H. H. The Aerodynamic Design of Section Shapes for Swept Wings. *Advances in Aeronautical Sciences*, Vol. 3. Proc. 2nd Int. Congr. Aer. Sci. Zurich, 1960. Pergamon Press, 1962.
2. Holder, D. W. The Transonic Flow Past Two-Dimensional Aerofoils. *J. Royal Aero. Soc.*, Vol. 68, August, 1964.
3. Pollock, N. Two-Dimensional Aerofoils at Transonic Speeds. ARL Aero Note 314, April, 1969.
4. Whitcomb, R. T. Review of NASA Supercritical Aerofoils. ICAS Paper 74-10, 1974.
5. Fulker, J. L. Aerodynamic Data for RAE 9550, A Supercritical Aerofoil. RAE TR 75068, 1975.
6. Tanner, M. Reduction of Base Drag. *Prog. Aerospace Sci.*, Vol. 16, pp. 369-384. D. Küchemann, Ed. Pergamon Press, 1975.
7. Tanner, M. A method for Reducing the Base Drag of Wings with Blunt Trailing Edge. *Aero. Quart.*, Vol. 23, Part 1, 1972, pp. 15-23.
8. Pollock, N. Segmented Blunt Trailing Edges at Subsonic and Transonic Speeds. ARL Aero Rpt. 137, February, 1972.
9. Wood, C. J. The Effect of Base Bleed on a Periodic Wake. *J. Royal Aero. Soc.*, Vol. 68, July, 1964.
10. Bearman, P. W. The Effect of Base Bleed on the Flow Behind a Two-Dimensional Model with a Blunt Trailing Edge. *Aero. Quart.*, Vol. 18, August, 1967.
11. Pollock, N. The Effect of Bleed on Two-Dimensional Base Flow at Subsonic, Transonic and Low Supersonic Speeds. ARL Aero. Note 381, November, 1978.
12. Abdul-Kadir, F. F. and Gibbings, J. C. The Transonic Flow Past a Blunt Base. Part III—The Base Pressure. University of Liverpool, Dept. of Mech. Eng. Report FM/32/77, January, 1977.
13. Wimbrow, W. R. Effects of Base Bleed on the Base Pressure of Blunt-Trailing-Edge Aerofoils at Supersonic Speeds. NACA, RM, A54A07, March, 1954.
14. Fuller, L. and Reid, J. Experiments on Two-Dimensional Base Flow at  $M = 2.4$ . ARC, R & M 3064, 1958.
15. Sirex, M. Pression de Culot et Processus de Mélange Turbulent en Écoulement Supersonique Plan. *La Recherche Aéronautique*, No. 78, Sept.-Oct., 1960.
16. Ginoux, J. J. Effect of Gas Injection in Separated Supersonic Flows. TCEA, Tech. Note 7, February, 1962.
17. Motallebi, F. and Norbury, J. F. The Effect of Base Bleed on Vortex Shedding and Base Pressure in Compressible Flow. *J. Fluid. Mech.*, Vol. 110, 1981, pp. 273-292.
18. Hoerner, S. F. Fluid-Dynamic Drag, Chapter IX. *Hoerner Fluid Dynamics*, 1965.

19. Fairlie, B. D. and Pollock, N. Evaluation of Wall Interference Effects in a Two-Dimensional Transonic Wind Tunnel by Subsonic Linear Theory. ARL, Aero. Rpt. 151, February, 1979.
20. Nash, J. F., Quincey, V. G. and Callinan, J. Experiments on Two-Dimensional Base Flow at Subsonic and Transonic Speeds. ARC R & M 3427, 1963.

TABLE 1 - EXPERIMENTAL RESULTS ( $b/s=0$ )

MACH NO.	CO LOCAL	CO	REYN. NO.	CP SPACE	CP BLOCK	CP TOTAL
0.498	0.000	0.000	0.073	-0.482	-0.222	-0.482
0.498	0.000	0.000	0.098	-0.479	-0.220	-0.479
0.499	0.043	0.043	0.073	-0.394	-0.209	-0.394
0.500	0.032	0.032	0.095	-0.389	-0.209	-0.389
0.500	0.055	0.055	0.073	-0.350	-0.209	-0.350
0.499	0.050	0.050	0.091	-0.344	-0.203	-0.344
0.500	0.072	0.072	0.073	-0.309	-0.216	-0.309
0.498	0.066	0.066	0.095	-0.307	-0.213	-0.307
0.502	0.078	0.078	0.073	-0.260	-0.187	-0.260
0.498	0.076	0.076	0.098	-0.261	-0.182	-0.261
0.501	0.097	0.097	0.073	-0.218	-0.168	-0.218
0.500	0.102	0.102	0.108	-0.210	-0.165	-0.210
0.500	0.117	0.117	0.073	-0.149	-0.152	-0.149
0.500	0.119	0.119	0.098	-0.145	-0.151	-0.145
0.501	0.148	0.148	0.077	-0.130	-0.143	-0.130
0.502	0.147	0.147	0.101	-0.122	-0.139	-0.122
0.502	0.164	0.164	0.073	-0.118	-0.135	-0.118
0.499	0.166	0.166	0.095	-0.118	-0.136	-0.118
0.500	0.177	0.177	0.077	-0.113	-0.131	-0.113
0.500	0.176	0.176	0.098	-0.113	-0.131	-0.113
0.599	0.000	0.000	0.090	-0.478	-0.22	-0.478
0.599	0.037	0.037	0.086	-0.411	-0.22	-0.411
0.599	0.052	0.052	0.086	-0.359	-0.19	-0.359
0.602	0.071	0.071	0.086	-0.322	-0.231	-0.322
0.603	0.078	0.078	0.086	-0.250	-0.171	-0.250
0.601	0.092	0.092	0.086	-0.216	-0.165	-0.216
0.599	0.116	0.116	0.086	-0.153	-0.158	-0.153
0.602	0.145	0.145	0.090	-0.134	-0.145	-0.134
0.602	0.162	0.162	0.090	-0.132	-0.140	-0.132
0.601	0.175	0.175	0.090	-0.120	-0.136	-0.120
0.703	0.000	0.000	0.083	-0.499	-0.224	-0.499
0.498	0.000	0.000	0.101	-0.495	-0.229	-0.495
0.700	0.032	0.032	0.083	-0.414	-0.203	-0.414
0.700	0.033	0.033	0.099	-0.416	-0.205	-0.416
0.703	0.051	0.051	0.083	-0.351	-0.193	-0.351
0.700	0.052	0.052	0.099	-0.349	-0.189	-0.349
0.701	0.064	0.064	0.083	-0.442	-0.347	-0.442
0.701	0.070	0.070	0.099	-0.301	-0.206	-0.301
0.699	0.078	0.078	0.083	-0.260	-0.181	-0.260
0.700	0.078	0.078	0.098	-0.260	-0.178	-0.260
0.700	0.092	0.092	0.083	-0.216	-0.171	-0.216
0.700	0.090	0.090	0.099	-0.208	-0.169	-0.208
0.702	0.116	0.116	0.083	-0.163	-0.165	-0.163
0.702	0.118	0.118	0.099	-0.164	-0.167	-0.164
0.701	0.141	0.141	0.086	-0.147	-0.156	-0.147
0.697	0.143	0.143	0.103	-0.147	-0.169	-0.147
0.700	0.157	0.157	0.086	-0.142	-0.151	-0.142
0.700	0.157	0.157	0.099	-0.145	-0.150	-0.145
0.700	0.169	0.169	0.083	-0.140	-0.144	-0.140
0.700	0.167	0.167	0.099	-0.139	-0.144	-0.139

TABLE 1 (CONTINUED)

MACH NO.	CO LOCAL	CO	REYN. NO.	CP SPACE	CP BLOCK	CP TOTAL
0.800	0.000	0.000	0.091	-0.553	-0.230	-0.553
0.801	0.034	0.034	0.093	-0.428	-0.212	-0.428
0.799	0.049	0.049	0.091	-0.363	-0.203	-0.363
0.800	0.068	0.068	0.091	-0.291	-0.207	-0.291
0.800	0.082	0.082	0.091	-0.248	-0.190	-0.248
0.802	0.094	0.094	0.091	-0.214	-0.180	-0.214
0.798	0.117	0.117	0.091	-0.175	-0.173	-0.175
0.802	0.140	0.140	0.093	-0.158	-0.158	-0.158
0.802	0.152	0.152	0.096	-0.153	-0.156	-0.153
0.802	0.162	0.162	0.091	-0.142	-0.153	-0.142
0.851	0.000	0.000	0.095	-0.572	-0.225	-0.572
0.848	0.037	0.037	0.096	-0.441	-0.198	-0.441
0.852	0.050	0.050	0.095	-0.369	-0.201	-0.369
0.852	0.064	0.064	0.096	-0.282	-0.199	-0.282
0.851	0.080	0.080	0.095	-0.247	-0.186	-0.247
0.848	0.094	0.094	0.096	-0.208	-0.180	-0.208
0.848	0.116	0.116	0.096	-0.177	-0.174	-0.177
0.848	0.138	0.138	0.096	-0.236	-0.157	-0.236
0.851	0.146	0.146	0.099	-0.234	-0.239	-0.234
0.851	0.160	0.160	0.096	-0.151	-0.162	-0.151
0.874	0.000	0.000	0.098	-0.574	-0.211	-0.574
0.875	0.033	0.033	0.098	-0.427	-0.176	-0.427
0.877	0.049	0.049	0.098	-0.341	-0.184	-0.341
0.875	0.066	0.066	0.098	-0.259	-0.182	-0.259
0.875	0.079	0.079	0.096	-0.225	-0.174	-0.225
0.874	0.092	0.092	0.098	-0.198	-0.170	-0.198
0.875	0.115	0.115	0.098	-0.165	-0.163	-0.165
0.875	0.137	0.137	0.098	-0.155	-0.153	-0.155
0.877	0.149	0.149	0.101	-0.150	-0.156	-0.150
0.876	0.152	0.152	0.098	-0.154	-0.163	-0.154
0.901	0.000	0.000	0.081	-0.503	-0.134	-0.503
0.899	0.000	0.000	0.099	-0.505	-0.133	-0.505
0.898	0.034	0.034	0.085	-0.356	-0.120	-0.356
0.899	0.033	0.033	0.099	-0.344	-0.124	-0.344
0.900	0.047	0.047	0.081	-0.241	-0.107	-0.241
0.899	0.048	0.048	0.098	-0.231	-0.124	-0.231
0.898	0.065	0.065	0.081	-0.194	-0.132	-0.194
0.899	0.064	0.064	0.099	-0.187	-0.144	-0.187
0.900	0.080	0.080	0.081	-0.174	-0.130	-0.174
0.901	0.079	0.079	0.099	-0.168	-0.135	-0.168
0.898	0.089	0.089	0.081	-0.171	-0.133	-0.171
0.902	0.090	0.090	0.099	-0.161	-0.133	-0.161
0.899	0.113	0.113	0.081	-0.126	-0.127	-0.126
0.898	0.115	0.115	0.099	-0.109	-0.128	-0.129
0.900	0.137	0.137	0.085	-0.118	-0.120	-0.118
0.901	0.137	0.137	0.099	-0.125	-0.128	-0.125
0.901	0.145	0.145	0.081	-0.127	-0.136	-0.127
0.898	0.146	0.146	0.103	-0.127	-0.133	-0.127
0.902	0.153	0.153	0.085	-0.120	-0.133	-0.120
0.901	0.153	0.153	0.099	-0.127	-0.138	-0.127

TABLE 1 (CONTINUED)

MACH NO.	CO LOCAL	CO	REYN. NO.	CP SPACE	CP BLOCK	CP TOTAL
0.925	0.000	0.000	0.083	-0.543	-0.230	-0.543
0.923	0.023	0.023	0.086	-0.390	-0.286	-0.390
0.926	0.048	0.048	0.083	-0.265	-0.216	-0.265
0.924	0.063	0.063	0.083	-0.238	-0.208	-0.238
0.926	0.077	0.077	0.083	-0.215	-0.194	-0.215
0.924	0.091	0.091	0.083	-0.207	-0.156	-0.207
0.924	0.112	0.112	0.083	-0.143	-0.121	-0.143
0.927	0.135	0.135	0.086	-0.154	-0.122	-0.154
0.926	0.140	0.140	0.083	-0.121	-0.109	-0.121
0.926	0.153	0.153	0.083	-0.118	-0.104	-0.118
0.952	0.000	0.000	0.085	-0.711	-0.216	-0.711
0.949	0.031	0.031	0.088	-0.386	-0.307	-0.386
0.952	0.048	0.048	0.081	-0.333	-0.280	-0.333
0.949	0.063	0.063	0.081	-0.316	-0.279	-0.316
0.950	0.076	0.076	0.085	-0.295	-0.273	-0.295
0.950	0.093	0.093	0.081	-0.290	-0.240	-0.290
0.950	0.111	0.111	0.085	-0.244	-0.222	-0.244
0.950	0.135	0.135	0.085	-0.247	-0.196	-0.247
0.951	0.144	0.144	0.081	-0.219	-0.200	-0.219
0.951	0.154	0.154	0.085	-0.224	-0.196	-0.224
0.974	0.000	0.000	0.083	-0.747	-0.279	-0.747
0.975	0.037	0.037	0.088	-0.508	-0.310	-0.508
0.976	0.049	0.049	0.083	-0.462	-0.357	-0.462
0.975	0.066	0.066	0.083	-0.407	-0.357	-0.407
0.974	0.076	0.076	0.086	-0.395	-0.357	-0.395
0.975	0.092	0.092	0.083	-0.352	-0.337	-0.352
0.974	0.109	0.109	0.086	-0.320	-0.298	-0.320
0.975	0.132	0.132	0.086	-0.322	-0.292	-0.322
0.974	0.142	0.142	0.083	-0.319	-0.274	-0.319
0.976	0.152	0.152	0.086	-0.340	-0.263	-0.340
1.002	0.000	0.000	0.085	-0.846	-0.347	-0.846
0.999	0.033	0.033	0.090	-0.581	-0.362	-0.581
1.002	0.055	0.055	0.085	-0.551	-0.545	-0.551
1.001	0.062	0.062	0.085	-0.521	-0.475	-0.521
1.002	0.073	0.073	0.088	-0.498	-0.453	-0.498
0.998	0.093	0.093	0.088	-0.437	-0.445	-0.437
1.000	0.111	0.111	0.088	-0.397	-0.387	-0.397
1.002	0.128	0.128	0.088	-0.424	-0.398	-0.424
1.002	0.142	0.142	0.085	-0.442	-0.383	-0.442
0.999	0.152	0.152	0.088	-0.438	-0.355	-0.438
1.102	0.000	0.000	0.052	-0.654	-0.739	-0.654
1.098	0.000	0.000	0.091	-0.710	-0.729	-0.710
1.100	0.038	0.038	0.058	-0.517	-0.721	-0.517
1.102	0.036	0.036	0.095	-0.481	-0.683	-0.481
1.097	0.054	0.054	0.052	-0.496	-0.722	-0.496
1.101	0.054	0.054	0.091	-0.449	-0.664	-0.449
1.099	0.063	0.063	0.057	-0.465	-0.682	-0.465
1.101	0.062	0.062	0.091	-0.439	-0.625	-0.439
1.099	0.069	0.069	0.054	-0.440	-0.657	-0.440
1.101	0.073	0.073	0.091	-0.410	-0.608	-0.410

TABLE 1 (CONTINUED)

MACH NO.	CO LOCAL	CO	REYN. NO.	CP SPACE	CP BLOCK	CP TOTAL
1.101	0.084	0.084	0.057	-0.422	-0.628	-0.422
1.101	0.087	0.087	0.091	-0.389	-0.578	-0.389
1.098	0.106	0.106	0.057	-0.412	-0.612	-0.412
1.100	0.107	0.107	0.091	-0.388	-0.565	-0.388
1.102	0.129	0.129	0.057	-0.418	-0.601	-0.418
1.098	0.132	0.132	0.093	-0.413	-0.567	-0.413
1.101	0.143	0.143	0.057	-0.443	-0.612	-0.443
1.101	0.142	0.142	0.091	-0.429	-0.573	-0.429
1.101	0.147	0.147	0.057	-0.446	-0.603	-0.446
1.099	0.155	0.155	0.093	-0.437	-0.568	-0.437
1.201	0.000	0.000	0.054	-0.497	-0.579	-0.497
1.200	0.040	0.040	0.060	-0.366	-0.574	-0.366
1.201	0.055	0.055	0.057	-0.335	-0.558	-0.335
1.199	0.066	0.066	0.057	-0.302	-0.514	-0.302
1.201	0.070	0.070	0.057	-0.290	-0.507	-0.290
1.198	0.086	0.086	0.060	-0.269	-0.475	-0.269
1.199	0.108	0.108	0.058	-0.246	-0.453	-0.246
1.200	0.131	0.131	0.060	-0.261	-0.451	-0.261
1.203	0.140	0.140	0.058	-0.328	-0.494	-0.328
1.199	0.155	0.155	0.058	-0.289	-0.446	-0.289
1.300	0.000	0.000	0.055	-0.431	-0.461	-0.431
1.301	0.039	0.039	0.062	-0.307	-0.476	-0.307
1.301	0.055	0.055	0.057	-0.286	-0.467	-0.286
1.303	0.057	0.057	0.060	-0.259	-0.448	-0.259
1.301	0.071	0.071	0.057	-0.241	-0.434	-0.241
1.300	0.087	0.087	0.062	-0.226	-0.422	-0.226
1.300	0.109	0.109	0.060	-0.233	-0.407	-0.233
1.301	0.135	0.135	0.062	-0.252	-0.395	-0.252
1.299	0.149	0.149	0.060	-0.279	-0.398	-0.279
1.299	0.158	0.158	0.060	-0.287	-0.393	-0.287
1.351	0.000	0.000	0.058	-0.402	-0.423	-0.402
1.350	0.045	0.045	0.065	-0.285	-0.437	-0.285
1.348	0.053	0.053	0.058	-0.266	-0.430	-0.266
1.349	0.059	0.059	0.060	-0.238	-0.414	-0.238
1.348	0.069	0.069	0.060	-0.222	-0.406	-0.222
1.349	0.087	0.087	0.062	-0.207	-0.390	-0.207
1.350	0.105	0.105	0.060	-0.219	-0.373	-0.219
1.351	0.137	0.137	0.062	-0.230	-0.359	-0.230
1.348	0.151	0.151	0.060	-0.265	-0.367	-0.265
1.350	0.161	0.161	0.062	-0.279	-0.358	-0.279

TABLE 2 - EXPERIMENTAL RESULTS ( $b/s = 1.20$ )

MACH NO.	C <sub>Q</sub> LOCAL	C <sub>Q</sub>	REYN. NO.	CP SPACE	CP BLOCK	CP TOTAL
0.501	0.000	0.000	0.073	-0.392	-0.207	-0.291
0.498	0.000	0.000	0.098	-0.387	-0.207	-0.299
0.502	0.051	0.023	0.073	-0.288	-0.195	-0.237
0.502	0.056	0.025	0.098	-0.292	-0.192	-0.237
0.502	0.063	0.029	0.073	-0.259	-0.188	-0.220
0.499	0.067	0.030	0.098	-0.261	-0.189	-0.222
0.500	0.078	0.036	0.077	-0.252	-0.190	-0.218
0.499	0.079	0.036	0.098	-0.265	-0.189	-0.223
0.500	0.079	0.036	0.077	-0.232	-0.168	-0.197
0.501	0.088	0.040	0.098	-0.249	-0.168	-0.205
0.502	0.096	0.044	0.073	-0.219	-0.158	-0.186
0.500	0.099	0.045	0.095	-0.217	-0.154	-0.182
0.500	0.129	0.058	0.073	-0.169	-0.150	-0.158
0.500	0.128	0.058	0.098	-0.175	-0.148	-0.160
0.500	0.151	0.069	0.073	-0.177	-0.137	-0.155
0.501	0.150	0.068	0.098	-0.182	-0.138	-0.158
0.499	0.181	0.082	0.077	-0.160	-0.137	-0.147
0.501	0.178	0.081	0.098	-0.165	-0.136	-0.149
0.600	0.000	0.000	0.090	-0.411	-0.217	-0.305
0.599	0.055	0.025	0.086	-0.290	-0.186	-0.233
0.599	0.064	0.029	0.086	-0.251	-0.179	-0.212
0.600	0.075	0.034	0.090	-0.261	-0.182	-0.218
0.598	0.085	0.039	0.090	-0.255	-0.165	-0.206
0.600	0.100	0.045	0.086	-0.227	-0.156	-0.188
0.601	0.125	0.057	0.086	-0.183	-0.151	-0.165
0.602	0.151	0.069	0.086	-0.194	-0.141	-0.165
0.602	0.177	0.080	0.090	-0.174	-0.139	-0.155
0.701	0.000	0.000	0.083	-0.429	-0.217	-0.313
0.699	0.010	0.004	0.101	-0.421	-0.215	-0.308
0.703	0.051	0.023	0.083	-0.290	-0.188	-0.234
0.699	0.054	0.025	0.101	-0.299	-0.191	-0.240
0.698	0.063	0.029	0.083	-0.246	-0.181	-0.210
0.701	0.065	0.030	0.099	-0.247	-0.181	-0.211
0.701	0.072	0.033	0.083	-0.255	-0.185	-0.217
0.699	0.079	0.036	0.099	-0.263	-0.185	-0.220
0.702	0.085	0.039	0.086	-0.259	-0.168	-0.209
0.700	0.084	0.038	0.103	-0.265	-0.168	-0.212
0.700	0.101	0.046	0.083	-0.238	-0.160	-0.195
0.700	0.102	0.047	0.099	-0.239	-0.161	-0.197
0.698	0.130	0.059	0.083	-0.195	-0.158	-0.175
0.699	0.130	0.059	0.101	-0.199	-0.159	-0.177
0.699	0.151	0.068	0.083	-0.206	-0.148	-0.174
0.698	0.151	0.069	0.101	-0.211	-0.150	-0.178
0.701	0.173	0.079	0.086	-0.188	-0.147	-0.166
0.700	0.172	0.078	0.103	-0.187	-0.146	-0.164
0.802	0.000	0.000	0.091	-0.458	-0.216	-0.326
0.801	0.050	0.023	0.091	-0.304	-0.206	-0.251
0.801	0.064	0.029	0.091	-0.248	-0.195	-0.219
0.800	0.075	0.034	0.091	-0.264	-0.195	-0.226
0.798	0.087	0.039	0.091	-0.272	-0.179	-0.221

TABLE 2 (CONTINUED)

MACH NO.	CO LOCAL	CO	REYN. NO.	CP SPACE	CP BLOCK	CP TOTAL
0.799	0.105	0.048	0.091	-0.251	-0.173	-0.208
0.801	0.127	0.058	0.091	-0.216	-0.168	-0.190
0.800	0.150	0.068	0.091	-0.223	-0.158	-0.188
0.801	0.167	0.076	0.093	-0.206	-0.157	-0.179
0.850	0.000	0.000	0.096	-0.447	-0.206	-0.316
0.848	0.056	0.026	0.096	-0.120	-0.030	-0.071
0.850	0.064	0.029	0.095	-0.242	-0.190	-0.213
0.850	0.075	0.034	0.096	-0.258	-0.189	-0.220
0.850	0.087	0.039	0.096	-0.268	-0.177	-0.218
0.850	0.105	0.048	0.096	-0.255	-0.170	-0.209
0.850	0.127	0.058	0.095	-0.216	-0.163	-0.187
0.849	0.149	0.068	0.096	-0.229	-0.156	-0.189
0.851	0.162	0.074	0.096	-0.216	-0.151	-0.181
0.875	0.000	0.000	0.098	-0.403	-0.174	-0.278
0.875	0.053	0.024	0.098	-0.237	-0.166	-0.198
0.874	0.065	0.029	0.096	-0.224	-0.174	-0.197
0.873	0.077	0.035	0.098	-0.233	-0.168	-0.197
0.876	0.088	0.040	0.098	-0.240	-0.156	-0.194
0.876	0.105	0.048	0.098	-0.234	-0.154	-0.190
0.876	0.127	0.058	0.096	-0.198	-0.150	-0.172
0.876	0.148	0.067	0.098	-0.209	-0.140	-0.172
0.876	0.161	0.073	0.098	-0.205	-0.141	-0.170
0.902	0.000	0.000	0.081	-0.325	-0.160	-0.235
0.898	0.011	0.005	0.099	-0.319	-0.178	-0.242
0.902	0.049	0.022	0.081	-0.162	-0.116	-0.137
0.901	0.052	0.024	0.099	-0.163	-0.119	-0.139
0.902	0.063	0.029	0.081	-0.156	-0.124	-0.139
0.903	0.064	0.029	0.099	-0.154	-0.125	-0.138
0.901	0.072	0.033	0.081	-0.158	-0.116	-0.135
0.900	0.074	0.034	0.099	-0.238	-0.193	-0.213
0.900	0.083	0.038	0.085	-0.177	-0.105	-0.138
0.902	0.088	0.040	0.099	-0.163	-0.103	-0.130
0.902	0.103	0.047	0.081	-0.158	-0.100	-0.127
0.899	0.105	0.048	0.099	-0.170	-0.109	-0.137
0.900	0.127	0.058	0.081	-0.139	-0.103	-0.119
0.901	0.126	0.057	0.099	-0.138	-0.103	-0.119
0.900	0.147	0.067	0.081	-0.153	-0.105	-0.127
0.901	0.149	0.068	0.099	-0.147	-0.095	-0.118
0.901	0.161	0.073	0.085	-0.160	-0.103	-0.129
0.899	0.161	0.073	0.099	-0.165	-0.113	-0.137
0.928	0.000	0.000	0.085	-0.645	-0.229	-0.418
0.926	0.052	0.023	0.083	-0.265	-0.216	-0.238
0.925	0.063	0.029	0.083	-0.256	-0.213	-0.233
0.922	0.076	0.035	0.083	-0.238	-0.181	-0.207
0.924	0.085	0.039	0.086	-0.266	-0.166	-0.211
0.927	0.102	0.046	0.083	-0.255	-0.166	-0.207
0.925	0.128	0.058	0.083	-0.226	-0.157	-0.188
0.926	0.147	0.067	0.083	-0.215	-0.138	-0.173
0.924	0.161	0.073	0.083	-0.217	-0.132	-0.170
0.948	0.000	0.000	0.085	-0.378	-0.288	-0.329

TABLE 2 (CONTINUED)

MACH NO.	CO LOCAL	CO	REYN. NO.	CP SPACE	CP BLOCK	CP TOTAL
0.949	0.053	0.024	0.085	-0.344	-0.302	-0.321
0.950	0.063	0.029	0.081	-0.335	-0.292	-0.311
0.951	0.076	0.035	0.085	-0.335	-0.279	-0.304
0.948	0.085	0.039	0.088	-0.343	-0.266	-0.301
0.949	0.102	0.046	0.081	-0.336	-0.253	-0.291
0.952	0.124	0.057	0.085	-0.327	-0.255	-0.288
0.952	0.146	0.066	0.085	-0.331	-0.229	-0.275
0.951	0.157	0.072	0.085	-0.302	-0.207	-0.250
0.976	0.012	0.006	0.086	-0.756	-0.343	-0.531
0.977	0.049	0.022	0.086	-0.453	-0.363	-0.404
0.974	0.063	0.029	0.083	-0.416	-0.358	-0.384
0.976	0.074	0.034	0.086	-0.430	-0.358	-0.391
0.975	0.084	0.038	0.086	-0.444	-0.349	-0.392
0.975	0.100	0.046	0.083	-0.435	-0.340	-0.383
0.978	0.123	0.056	0.083	-0.421	-0.329	-0.371
0.973	0.144	0.065	0.083	-0.394	-0.314	-0.351
0.977	0.157	0.071	0.086	-0.376	-0.313	-0.341
1.001	0.000	0.000	0.088	-0.916	-0.527	-0.704
1.002	0.049	0.022	0.085	-0.576	-0.515	-0.542
1.001	0.061	0.028	0.085	-0.547	-0.520	-0.532
1.002	0.074	0.034	0.088	-0.546	-0.504	-0.523
1.002	0.087	0.039	0.090	-0.578	-0.521	-0.547
1.001	0.098	0.045	0.085	-0.550	-0.471	-0.507
1.000	0.124	0.056	0.085	0.507	0.463	0.483
0.999	0.142	0.064	0.085	-0.481	-0.436	-0.456
0.998	0.158	0.072	0.088	-0.516	-0.439	-0.474
1.100	0.000	0.000	0.054	-0.701	-0.667	-0.683
1.099	0.000	0.000	0.091	-0.749	-0.667	-0.704
1.099	0.046	0.021	0.057	-0.498	-0.716	-0.617
1.099	0.050	0.023	0.091	-0.485	-0.682	-0.593
1.103	0.064	0.029	0.057	-0.472	-0.699	-0.596
1.100	0.060	0.027	0.091	-0.463	-0.668	-0.575
1.102	0.068	0.031	0.052	-0.454	-0.676	-0.575
1.098	0.075	0.034	0.091	-0.464	-0.654	-0.568
1.099	0.081	0.037	0.057	-0.470	-0.674	-0.581
1.099	0.088	0.040	0.093	-0.481	-0.645	-0.570
1.101	0.095	0.043	0.054	-0.459	-0.660	-0.569
1.101	0.098	0.045	0.091	-0.467	-0.635	-0.559
1.100	0.122	0.055	0.054	-0.442	-0.642	-0.551
1.100	0.124	0.056	0.091	-0.430	-0.622	-0.535
1.103	0.140	0.064	0.054	-0.453	-0.631	-0.550
1.101	0.143	0.065	0.091	-0.444	-0.616	-0.538
1.101	0.157	0.072	0.057	-0.479	-0.635	-0.564
1.098	0.158	0.072	0.093	-0.458	-0.618	-0.545
1.200	0.000	0.000	0.057	-0.547	-0.511	-0.527
1.200	0.048	0.022	0.058	-0.336	-0.547	-0.451
1.199	0.062	0.028	0.058	-0.309	-0.525	-0.427
1.202	0.068	0.031	0.054	-0.297	-0.512	-0.414
1.202	0.083	0.038	0.058	-0.303	-0.501	-0.411
1.199	0.096	0.044	0.057	-0.312	-0.507	-0.418

TABLE 2 (CONTINUED)

MACH NO.	CO LOCAL	CO	REYN. NO.	CP SPACE	CP BLOCK	CP TOTAL
1.202	0.123	0.056	0.057	-0.279	-0.485	-0.391
1.202	0.142	0.064	0.057	-0.289	-0.476	-0.391
1.198	0.160	0.073	0.058	-0.317	-0.479	-0.405
1.302	0.000	0.000	0.060	-0.430	-0.424	-0.426
1.298	0.046	0.021	0.060	-0.271	-0.460	-0.374
1.300	0.062	0.028	0.060	-0.245	-0.447	-0.355
1.300	0.070	0.032	0.055	-0.241	-0.439	-0.349
1.303	0.084	0.038	0.060	-0.240	-0.421	-0.339
1.298	0.098	0.045	0.057	-0.234	-0.418	-0.334
1.302	0.126	0.057	0.057	-0.228	-0.405	-0.324
1.300	0.145	0.066	0.060	-0.247	-0.396	-0.328
1.300	0.163	0.074	0.060	-0.254	-0.398	-0.333
1.348	0.000	0.000	0.060	-0.388	-0.393	-0.391
1.348	0.048	0.022	0.060	-0.244	-0.420	-0.340
1.347	0.062	0.028	0.060	-0.225	-0.411	-0.326
1.347	0.071	0.032	0.055	-0.212	-0.399	-0.314
1.348	0.085	0.039	0.062	-0.216	-0.385	-0.308
1.348	0.099	0.045	0.058	-0.201	-0.379	-0.298
1.347	0.127	0.058	0.058	-0.199	-0.370	-0.292
1.348	0.147	0.067	0.060	-0.227	-0.360	-0.299
1.349	0.165	0.075	0.062	-0.234	-0.360	-0.303

TABLE 3 - EXPERIMENTAL RESULTS ( $b/s = 2.67$ )

MACH NO.	CO LOCAL	CO	REYN. NO.	CP SPACE	CP BLOCK	CP TOTAL
0.502	0.000	0.000	0.073	-0.389	-0.213	-0.261
0.501	0.000	0.000	0.098	-0.390	-0.214	-0.262
0.499	0.056	0.015	0.098	-0.284	-0.199	-0.222
0.502	0.064	0.017	0.073	-0.237	-0.176	-0.192
0.500	0.065	0.018	0.101	-0.237	-0.176	-0.193
0.501	0.077	0.021	0.077	-0.228	-0.170	-0.186
0.501	0.081	0.022	0.098	-0.223	-0.174	-0.187
0.503	0.097	0.027	0.073	-0.241	-0.166	-0.186
0.499	0.105	0.029	0.073	-0.224	-0.166	-0.182
0.500	0.109	0.030	0.098	-0.222	-0.166	-0.181
0.499	0.116	0.031	0.073	-0.183	-0.165	-0.170
0.498	0.117	0.032	0.095	-0.189	-0.167	-0.173
0.502	0.135	0.037	0.077	-0.173	-0.167	-0.168
0.500	0.135	0.037	0.098	-0.178	-0.167	-0.170
0.502	0.159	0.043	0.073	-0.171	-0.162	-0.164
0.497	0.159	0.043	0.098	-0.173	-0.165	-0.167
0.600	0.000	0.000	0.086	-0.411	-0.221	-0.273
0.597	0.056	0.015	0.086	-0.271	-0.187	-0.210
0.602	0.065	0.018	0.090	-0.246	-0.180	-0.198
0.602	0.080	0.022	0.090	-0.236	-0.179	-0.195
0.601	0.098	0.027	0.086	-0.254	-0.171	-0.194
0.603	0.107	0.029	0.086	-0.230	-0.173	-0.188
0.599	0.117	0.032	0.086	-0.199	-0.174	-0.181
0.601	0.133	0.036	0.090	-0.188	-0.172	-0.176
0.601	0.156	0.042	0.086	-0.185	-0.168	-0.173
0.700	0.000	0.000	0.083	-0.425	-0.227	-0.281
0.700	0.000	0.000	0.099	-0.435	-0.229	-0.285
0.698	0.055	0.015	0.080	-0.274	-0.193	-0.215
0.698	0.055	0.015	0.098	-0.271	-0.193	-0.214
0.701	0.063	0.017	0.086	-0.254	-0.191	-0.208
0.699	0.069	0.019	0.101	-0.262	-0.193	-0.212
0.700	0.077	0.021	0.086	-0.249	-0.187	-0.204
0.701	0.080	0.022	0.090	-0.246	-0.191	-0.206
0.698	0.098	0.027	0.083	-0.262	-0.182	-0.204
0.699	0.098	0.027	0.101	-0.263	-0.185	-0.206
0.700	0.105	0.028	0.083	-0.235	-0.183	-0.197
0.699	0.107	0.029	0.101	-0.237	-0.184	-0.198
0.700	0.116	0.032	0.083	-0.206	-0.184	-0.190
0.698	0.116	0.032	0.098	-0.212	-0.184	-0.192
0.700	0.132	0.036	0.083	-0.199	-0.180	-0.185
0.698	0.132	0.036	0.101	-0.203	-0.183	-0.188
0.703	0.152	0.041	0.083	-0.202	-0.177	-0.184
0.699	0.153	0.042	0.098	-0.203	-0.179	-0.185
0.800	0.000	0.000	0.091	-0.480	-0.249	-0.312
0.801	0.054	0.015	0.091	-0.271	-0.207	-0.225
0.801	0.067	0.018	0.091	-0.264	-0.204	-0.220
0.801	0.079	0.021	0.093	-0.250	-0.201	-0.214
0.799	0.097	0.026	0.091	-0.271	-0.194	-0.215
0.797	0.107	0.029	0.091	-0.245	-0.194	-0.208
0.801	0.117	0.032	0.091	-0.222	-0.193	-0.201

TABLE 3 (CONTINUED)

MACH NO.	CO LOCAL	CO	REYN. NO.	CP SPACE	CP BLOCK	CP TOTAL
0.802	0.131	0.036	0.091	-0.219	-0.193	-0.200
0.801	0.153	0.042	0.091	-0.226	-0.190	-0.200
0.848	0.000	0.000	0.096	-0.476	-0.241	-0.305
0.847	0.054	0.015	0.095	-0.267	-0.202	-0.220
0.850	0.068	0.019	0.096	-0.260	-0.199	-0.216
0.850	0.080	0.022	0.096	-0.242	-0.198	-0.210
0.850	0.097	0.027	0.096	-0.261	-0.193	-0.212
0.848	0.107	0.029	0.096	-0.241	-0.192	-0.205
0.851	0.118	0.032	0.095	-0.224	-0.193	-0.201
0.853	0.131	0.036	0.096	-0.220	-0.192	-0.199
0.852	0.155	0.042	0.095	-0.234	-0.190	-0.202
0.874	0.000	0.000	0.098	-0.419	-0.203	-0.262
0.874	0.053	0.014	0.096	-0.243	-0.182	-0.199
0.876	0.068	0.019	0.098	-0.239	-0.182	-0.197
0.875	0.082	0.022	0.098	-0.220	-0.182	-0.192
0.876	0.097	0.027	0.098	-0.230	-0.175	-0.190
0.877	0.106	0.029	0.098	-0.222	-0.178	-0.190
0.874	0.117	0.032	0.098	-0.207	-0.185	-0.191
0.874	0.132	0.036	0.098	-0.210	-0.183	-0.190
0.875	0.155	0.042	0.098	-0.219	-0.178	-0.189
0.902	0.000	0.000	0.081	-0.249	-0.114	-0.151
0.901	0.000	0.000	0.099	-0.234	-0.118	-0.150
0.901	0.053	0.014	0.081	-0.183	-0.138	-0.150
0.900	0.053	0.014	0.098	-0.183	-0.138	-0.150
0.899	0.065	0.018	0.085	-0.180	-0.139	-0.150
0.899	0.068	0.019	0.099	-0.183	-0.139	-0.151
0.900	0.079	0.022	0.081	-0.165	-0.136	-0.144
0.901	0.083	0.023	0.099	-0.170	-0.142	-0.149
0.902	0.096	0.026	0.081	-0.182	-0.129	-0.144
0.898	0.097	0.027	0.099	-0.179	-0.137	-0.148
0.901	0.105	0.029	0.081	-0.171	-0.140	-0.148
0.900	0.106	0.029	0.099	-0.168	-0.136	-0.145
0.901	0.117	0.032	0.081	-0.156	-0.136	-0.142
0.902	0.117	0.032	0.099	-0.153	-0.133	-0.138
0.898	0.131	0.036	0.081	-0.158	-0.139	-0.144
0.900	0.131	0.036	0.099	-0.163	-0.147	-0.152
0.901	0.153	0.042	0.081	-0.163	-0.136	-0.143
0.898	0.154	0.042	0.099	-0.166	-0.140	-0.147
0.925	0.032	0.009	0.083	-0.289	-0.293	-0.292
0.924	0.051	0.014	0.083	-0.235	-0.217	-0.222
0.925	0.065	0.018	0.086	-0.258	-0.216	-0.228
0.926	0.080	0.022	0.083	-0.239	-0.209	-0.217
0.926	0.095	0.026	0.083	-0.264	-0.202	-0.219
0.925	0.105	0.029	0.086	-0.231	-0.185	-0.198
0.924	0.118	0.032	0.083	-0.205	-0.177	-0.185
0.924	0.133	0.036	0.083	-0.215	-0.164	-0.178
0.924	0.157	0.043	0.083	-0.256	-0.164	-0.189
0.948	0.000	0.000	0.088	-0.383	-0.327	-0.342
0.950	0.051	0.014	0.085	-0.311	-0.292	-0.297
0.949	0.066	0.018	0.088	-0.321	-0.281	-0.292

TABLE 3 (CONTINUED)

MACH NO.	CO LOCAL	CO	REYN. NO.	CP SPACE	CP BLOCK	CP TOTAL
0.949	0.080	0.022	0.085	-0.298	-0.278	-0.283
0.950	0.092	0.025	0.085	-0.324	-0.272	-0.286
0.950	0.106	0.029	0.085	-0.296	-0.263	-0.272
0.949	0.119	0.032	0.085	-0.290	-0.257	-0.266
0.953	0.135	0.037	0.085	-0.311	-0.255	-0.270
0.949	0.157	0.043	0.081	-0.342	-0.255	-0.279
0.973	0.012	0.003	0.086	-0.621	-0.356	-0.428
0.974	0.050	0.014	0.086	-0.404	-0.353	-0.367
0.977	0.066	0.018	0.088	-0.447	-0.387	-0.404
0.976	0.081	0.022	0.086	-0.432	-0.389	-0.401
0.976	0.092	0.025	0.086	-0.419	-0.365	-0.379
0.976	0.105	0.029	0.086	-0.405	-0.338	-0.356
0.975	0.121	0.033	0.086	-0.393	-0.330	-0.347
0.976	0.137	0.037	0.086	-0.424	-0.341	-0.364
0.975	0.156	0.043	0.083	-0.431	-0.328	-0.356
0.999	0.000	0.000	0.088	-0.671	-0.511	-0.554
0.999	0.051	0.014	0.088	-0.561	-0.551	-0.554
0.999	0.067	0.018	0.090	-0.546	-0.566	-0.560
1.001	0.080	0.022	0.088	-0.540	-0.577	-0.567
0.999	0.094	0.026	0.085	-0.538	-0.539	-0.539
1.000	0.108	0.029	0.088	-0.528	-0.504	-0.511
1.000	0.121	0.033	0.088	-0.526	-0.488	-0.499
1.000	0.137	0.037	0.088	-0.545	-0.519	-0.526
1.000	0.156	0.042	0.085	-0.572	-0.580	-0.578
1.099	0.000	0.000	0.057	-0.578	-0.672	-0.647
1.100	0.000	0.000	0.093	-0.555	-0.664	-0.634
1.100	0.048	0.013	0.054	-0.480	-0.690	-0.633
1.098	0.051	0.014	0.091	-0.458	-0.660	-0.605
1.101	0.063	0.017	0.054	-0.447	-0.670	-0.609
1.102	0.066	0.018	0.095	-0.439	-0.652	-0.594
1.097	0.078	0.021	0.057	-0.442	-0.678	-0.613
1.099	0.080	0.022	0.093	-0.427	-0.650	-0.589
1.100	0.095	0.026	0.054	-0.429	-0.667	-0.602
1.100	0.096	0.026	0.091	-0.423	-0.646	-0.595
1.099	0.108	0.029	0.054	-0.442	-0.667	-0.606
1.103	0.109	0.030	0.091	-0.426	-0.644	-0.585
1.098	0.123	0.033	0.052	-0.440	-0.665	-0.603
1.100	0.123	0.033	0.091	-0.425	-0.645	-0.585
1.099	0.138	0.038	0.054	-0.445	-0.663	-0.604
1.102	0.137	0.037	0.091	-0.436	-0.646	-0.589
1.099	0.152	0.041	0.052	-0.443	-0.653	-0.596
1.101	0.156	0.043	0.091	-0.446	-0.638	-0.584
1.199	0.000	0.000	0.058	-0.402	-0.508	-0.479
1.201	0.049	0.013	0.057	-0.315	-0.528	-0.470
1.200	0.064	0.017	0.057	-0.284	-0.501	-0.442
1.202	0.079	0.021	0.058	-0.270	-0.499	-0.436
1.199	0.095	0.026	0.057	-0.275	-0.507	-0.446
1.200	0.109	0.030	0.057	-0.276	-0.502	-0.441
1.203	0.125	0.034	0.057	-0.270	-0.495	-0.433
1.202	0.118	0.032	0.057	-0.284	-0.497	-0.439

TABLE 3 (CONTINUED)

MACH NO.	CO LOCAL	CO	REYN. NO.	CP SPACE	CP BLOCK	CP TOTAL
1.198	0.153	0.042	0.057	-0.289	-0.497	-0.440
1.300	0.000	0.000	0.060	-0.320	-0.417	-0.391
1.297	0.050	0.014	0.057	-0.242	-0.435	-0.382
1.300	0.065	0.018	0.060	-0.216	-0.421	-0.345
1.300	0.081	0.022	0.060	-0.208	-0.418	-0.361
1.301	0.098	0.027	0.057	-0.209	-0.417	-0.360
1.300	0.111	0.030	0.060	-0.216	-0.416	-0.361
1.302	0.127	0.034	0.057	-0.213	-0.412	-0.358
1.298	0.143	0.039	0.057	-0.209	-0.415	-0.359
1.299	0.157	0.043	0.057	-0.217	-0.402	-0.352
1.347	0.000	0.000	0.060	-0.293	-0.384	-0.359
1.347	0.051	0.014	0.058	-0.215	-0.397	-0.347
1.348	0.067	0.018	0.060	-0.193	-0.385	-0.333
1.348	0.082	0.022	0.060	-0.185	-0.381	-0.328
1.346	0.099	0.027	0.060	-0.187	-0.382	-0.329
1.349	0.113	0.031	0.060	-0.189	-0.376	-0.325
1.350	0.128	0.035	0.058	-0.186	-0.373	-0.322
1.352	0.145	0.039	0.060	-0.191	-0.370	-0.321
1.344	0.158	0.043	0.058	-0.196	-0.367	-0.320

TABLE 4 - EXPERIMENTAL RESULTS ( $b/s = 10.16$ )

MACH NO.	CQ LOCAL	CQ	REYN. NO.	CP SPACE	CP BLOCK	CP TOTAL
0.500	0.020	0.002	0.073	-0.325	-0.278	-0.282
0.503	0.019	0.002	0.098	-0.328	-0.280	-0.284
0.500	0.062	0.006	0.073	-0.224	-0.227	-0.226
0.497	0.066	0.006	0.095	-0.223	-0.231	-0.230
0.500	0.100	0.009	0.077	-0.207	-0.233	-0.231
0.503	0.101	0.009	0.101	-0.212	-0.238	-0.236
0.503	0.114	0.010	0.073	-0.241	-0.235	-0.235
0.500	0.113	0.010	0.098	-0.207	-0.237	-0.234
0.503	0.126	0.011	0.073	-0.201	-0.234	-0.231
0.501	0.126	0.011	0.098	-0.200	-0.234	-0.231
0.501	0.146	0.013	0.077	-0.197	-0.234	-0.230
0.503	0.148	0.013	0.101	-0.199	-0.236	-0.233
0.501	0.160	0.014	0.073	-0.195	-0.233	-0.230
0.498	0.160	0.014	0.098	-0.198	-0.239	-0.235
0.503	0.181	0.016	0.077	-0.189	-0.234	-0.230
0.502	0.180	0.016	0.101	-0.191	-0.237	-0.233
0.601	0.016	0.001	0.086	-0.332	-0.295	-0.299
0.601	0.064	0.006	0.086	-0.236	-0.256	-0.254
0.600	0.101	0.009	0.086	-0.224	-0.260	-0.257
0.600	0.114	0.010	0.086	-0.219	-0.259	-0.256
0.600	0.126	0.011	0.086	-0.214	-0.259	-0.255
0.603	0.145	0.013	0.090	-0.217	-0.262	-0.258
0.603	0.159	0.014	0.086	-0.214	-0.260	-0.256
0.599	0.179	0.016	0.090	-0.203	-0.251	-0.247
0.699	0.017	0.002	0.083	-0.340	-0.315	-0.317
0.701	0.018	0.002	0.099	-0.341	-0.320	-0.321
0.699	0.065	0.006	0.083	-0.252	-0.282	-0.279
0.701	0.066	0.006	0.099	-0.254	-0.282	-0.279
0.699	0.089	0.008	0.083	-0.240	-0.284	-0.280
0.697	0.091	0.008	0.098	-0.244	-0.286	-0.282
0.703	0.102	0.009	0.086	-0.235	-0.273	-0.269
0.701	0.103	0.009	0.099	-0.237	-0.277	-0.273
0.700	0.112	0.010	0.083	-0.376	-0.423	-0.419
0.702	0.115	0.010	0.099	-0.233	-0.275	-0.271
0.699	0.127	0.011	0.083	-0.230	-0.275	-0.271
0.700	0.127	0.011	0.099	-0.230	-0.273	-0.269
0.699	0.146	0.013	0.086	-0.226	-0.267	-0.263
0.700	0.146	0.013	0.099	-0.224	-0.265	-0.261
0.699	0.159	0.014	0.083	-0.221	-0.264	-0.260
0.702	0.158	0.014	0.099	-0.216	-0.263	-0.259
0.699	0.178	0.016	0.083	-0.208	-0.261	-0.256
0.700	0.178	0.016	0.099	-0.205	-0.261	-0.256
0.798	0.019	0.002	0.091	-0.365	-0.357	-0.358
0.799	0.067	0.006	0.091	-0.256	-0.277	-0.275
0.799	0.092	0.008	0.091	-0.245	-0.273	-0.271
0.801	0.104	0.009	0.091	-0.241	-0.269	-0.267
0.803	0.116	0.010	0.091	-0.236	-0.267	-0.264
0.799	0.127	0.011	0.091	-0.232	-0.266	-0.262
0.800	0.146	0.013	0.093	-0.223	-0.264	-0.261
0.803	0.158	0.014	0.091	-0.219	-0.262	-0.259

TABLE 4 (CONTINUED)

MACH NO.	CO LOCAL	CO	REFN. NO.	CP SPACE	CP BLOCK	CP TOTAL
0.800	0.177	0.016	0.091	-0.210	-0.259	-0.255
0.847	0.021	0.002	0.095	-0.360	-0.359	-0.359
0.848	0.068	0.006	0.095	-0.248	-0.272	-0.270
0.850	0.092	0.008	0.095	-0.235	-0.266	-0.263
0.852	0.105	0.009	0.096	-0.227	-0.261	-0.258
0.852	0.117	0.010	0.095	-0.226	-0.260	-0.257
0.852	0.127	0.011	0.096	-0.221	-0.260	-0.256
0.849	0.146	0.013	0.096	-0.211	-0.259	-0.255
0.852	0.158	0.014	0.096	-0.207	-0.258	-0.253
0.848	0.176	0.016	0.095	-0.201	-0.255	-0.251
0.874	0.019	0.002	0.096	-0.312	-0.337	-0.335
0.875	0.068	0.006	0.098	-0.214	-0.263	-0.259
0.872	0.093	0.008	0.096	-0.214	-0.259	-0.255
0.876	0.105	0.009	0.098	-0.202	-0.250	-0.246
0.872	0.116	0.010	0.096	-0.205	-0.255	-0.251
0.874	0.127	0.011	0.098	-0.189	-0.249	-0.244
0.877	0.145	0.013	0.098	-0.180	-0.250	-0.243
0.872	0.158	0.014	0.098	-0.182	-0.251	-0.244
0.875	0.175	0.016	0.098	-0.172	-0.249	-0.242
0.902	0.000	0.000	0.081	-0.231	-0.210	-0.212
0.900	0.000	0.000	0.098	-0.221	-0.248	-0.246
0.898	0.063	0.006	0.081	-0.162	-0.242	-0.235
0.899	0.068	0.006	0.099	-0.165	-0.236	-0.230
0.899	0.091	0.008	0.078	-0.154	-0.238	-0.230
0.897	0.091	0.008	0.098	-0.158	-0.237	-0.230
0.903	0.103	0.009	0.081	-0.156	-0.222	-0.216
0.902	0.104	0.009	0.099	-0.166	-0.219	-0.214
0.899	0.116	0.010	0.078	-0.148	-0.229	-0.221
0.898	0.115	0.010	0.098	-0.154	-0.237	-0.229
0.901	0.126	0.011	0.078	-0.142	-0.230	-0.222
0.903	0.126	0.011	0.099	-0.144	-0.225	-0.218
0.900	0.144	0.013	0.081	-0.137	-0.231	-0.223
0.899	0.145	0.013	0.099	-0.137	-0.230	-0.221
0.903	0.156	0.014	0.081	-0.136	-0.228	-0.220
0.899	0.157	0.014	0.099	-0.134	-0.228	-0.220
0.902	0.174	0.016	0.086	-0.130	-0.227	-0.218
0.902	0.174	0.016	0.099	-0.131	-0.230	-0.221
0.925	0.000	0.000	0.080	-0.565	-0.278	-0.304
0.927	0.069	0.006	0.083	-0.271	-0.260	-0.261
0.925	0.095	0.009	0.080	-0.271	-0.252	-0.254
0.922	0.105	0.009	0.083	-0.254	-0.270	-0.273
0.925	0.119	0.011	0.080	-0.255	-0.270	-0.273
0.925	0.129	0.012	0.080	-0.256	-0.234	-0.236
0.926	0.147	0.013	0.083	-0.256	-0.228	-0.271
0.926	0.160	0.014	0.083	-0.262	-0.237	-0.239
0.928	0.177	0.016	0.088	-0.259	-0.238	-0.240
0.950	0.000	0.000	0.081	-0.611	-0.382	-0.402
0.952	0.069	0.006	0.081	-0.315	-0.311	-0.312
0.950	0.095	0.008	0.081	-0.316	-0.302	-0.303
0.952	0.108	0.010	0.085	-0.327	-0.314	-0.315

TABLE 4 (CONTINUED)

MACH NO.	CO LOCAL	CO	REVN. NO.	CP SPACE	CP BLOCK	CP TOTAL
0.949	0.122	0.011	0.081	-0.319	-0.307	-0.308
0.952	0.130	0.012	0.081	-0.322	-0.310	-0.311
0.950	0.149	0.013	0.085	-0.315	-0.298	-0.299
0.953	0.161	0.014	0.085	-0.325	-0.301	-0.303
0.952	0.177	0.016	0.086	-0.334	-0.298	-0.301
0.976	0.012	0.001	0.083	-0.586	-0.626	-0.622
0.976	0.070	0.006	0.083	-0.435	-0.424	-0.425
0.973	0.098	0.009	0.083	-0.430	-0.423	-0.424
0.976	0.109	0.010	0.086	-0.421	-0.408	-0.409
0.977	0.124	0.011	0.083	-0.408	-0.399	-0.399
0.974	0.133	0.012	0.083	-0.407	-0.412	-0.412
0.974	0.150	0.013	0.083	-0.400	-0.388	-0.389
0.974	0.161	0.014	0.083	-0.425	-0.422	-0.422
0.972	0.177	0.016	0.090	-0.417	-0.400	-0.402
1.001	0.000	0.000	0.085	-0.549	-0.881	-0.851
0.998	0.071	0.006	0.085	-0.493	-0.859	-0.826
1.002	0.099	0.009	0.085	-0.479	-0.862	-0.827
1.001	0.110	0.010	0.088	-0.473	-0.832	-0.800
1.002	0.124	0.011	0.085	-0.469	-0.874	-0.838
1.003	0.135	0.012	0.085	-0.468	-0.894	-0.854
1.002	0.150	0.013	0.088	-0.465	-0.837	-0.804
1.002	0.161	0.014	0.085	-0.455	-0.880	-0.842
0.999	0.177	0.016	0.088	-0.475	-0.843	-0.810
1.101	0.010	0.001	0.054	-0.421	-0.736	-0.708
1.099	0.010	0.001	0.091	-0.411	-0.751	-0.721
1.100	0.068	0.006	0.052	-0.365	-0.752	-0.717
1.099	0.073	0.007	0.091	-0.353	-0.744	-0.709
1.098	0.094	0.008	0.054	-0.351	-0.736	-0.702
1.101	0.100	0.009	0.091	-0.333	-0.738	-0.702
1.100	0.107	0.010	0.057	-0.344	-0.730	-0.696
1.101	0.112	0.010	0.091	-0.329	-0.736	-0.700
1.099	0.124	0.011	0.054	-0.342	-0.735	-0.699
1.102	0.126	0.011	0.088	-0.335	-0.739	-0.703
1.101	0.122	0.011	0.054	-0.497	-0.883	-0.849
1.099	0.135	0.012	0.088	-0.338	-0.746	-0.709
1.100	0.149	0.013	0.057	-0.327	-0.741	-0.704
1.101	0.152	0.014	0.093	-0.332	-0.740	-0.703
1.100	0.162	0.015	0.057	-0.331	-0.735	-0.699
1.099	0.163	0.015	0.091	-0.332	-0.738	-0.702
1.100	0.176	0.016	0.054	-0.324	-0.731	-0.694
1.099	0.178	0.016	0.091	-0.339	-0.748	-0.712
1.201	0.013	0.001	0.057	-0.248	-0.561	-0.533
1.199	0.068	0.006	0.057	-0.203	-0.581	-0.547
1.200	0.097	0.009	0.057	-0.193	-0.579	-0.545
1.197	0.109	0.010	0.057	-0.188	-0.579	-0.544
1.199	0.126	0.011	0.057	-0.178	-0.570	-0.535
1.203	0.135	0.012	0.055	-0.175	-0.561	-0.526
1.199	0.151	0.014	0.057	-0.172	-0.576	-0.540
1.201	0.165	0.015	0.058	-0.170	-0.572	-0.536
1.201	0.179	0.016	0.057	-0.168	-0.570	-0.534

TABLE 4 (CONTINUED)

MACH NO.	CO LOCAL	CO	REYN. NO.	CP SPACE	CP BLOCK	CP TOTAL
1.297	0.017	0.002	0.057	-0.197	-0.469	-0.444
1.299	0.071	0.006	0.057	-0.139	-0.475	-0.445
1.301	0.101	0.009	0.057	-0.127	-0.471	-0.441
1.303	0.112	0.010	0.057	-0.123	-0.466	-0.435
1.300	0.128	0.011	0.057	-0.125	-0.470	-0.439
1.298	0.137	0.012	0.057	-0.124	-0.469	-0.438
1.299	0.154	0.014	0.060	-0.109	-0.466	-0.434
1.297	0.167	0.015	0.057	-0.116	-0.472	-0.440
1.301	0.182	0.014	0.057	-0.112	-0.454	-0.423
1.344	0.015	0.001	0.060	-0.178	-0.429	-0.407
1.346	0.072	0.006	0.058	-0.122	-0.435	-0.407
1.346	0.101	0.009	0.058	-0.110	-0.431	-0.402
1.345	0.000	0.000	0.060	-0.108	3.749	3.403
1.347	0.130	0.012	0.058	-0.106	-0.428	-0.399
1.346	0.139	0.012	0.058	-0.105	-0.426	-0.397
1.349	0.156	0.014	0.062	-0.095	-0.426	-0.394
1.348	0.169	0.015	0.060	-0.101	-0.423	-0.394
1.347	0.185	0.017	0.058	-0.098	-0.414	-0.386

TABLE 5 - EXPERIMENTAL RESULTS  
 (Reynolds Number check,  $M_0=0.6$ ,  $b/s=1.20$ ,  $C_d \approx 0.01$ )

MACH NO.	C0 LOCAL	C0	REYN. NO.	CP SPACE	CP BLOCK	CP TOTAL
0.602	0.027	0.012	0.018	-0.373	-0.203	-0.280
0.602	0.024	0.011	0.029	-0.382	-0.207	-0.286
0.598	0.024	0.011	0.050	-0.396	-0.210	-0.294
0.601	0.024	0.011	0.086	-0.394	-0.206	-0.292
0.602	0.024	0.011	0.131	-0.397	-0.208	-0.294
0.599	0.037	0.017	0.183	-0.401	-0.209	-0.296

TABLE 6 - EXPERIMENTAL RESULTS

(Reynolds Number check,  $M_0=0.6$ ,  $b/s=1.20$ ,  $C_q=0.08$ )

MACH NO.	CQ LOCAL	CQ	REYN. NO.	CP SPACE	CP BLOCK	CP TOTAL
0.600	0.170	0.077	0.018	-0.173	-0.148	-0.159
0.604	0.170	0.077	0.029	-0.182	-0.141	-0.160
0.599	0.176	0.080	0.050	-0.198	-0.145	-0.169
0.598	0.177	0.081	0.086	-0.184	-0.140	-0.160
0.599	0.177	0.080	0.122	-0.179	-0.142	-0.159
0.600	0.176	0.080	0.170	-0.191	-0.143	-0.165

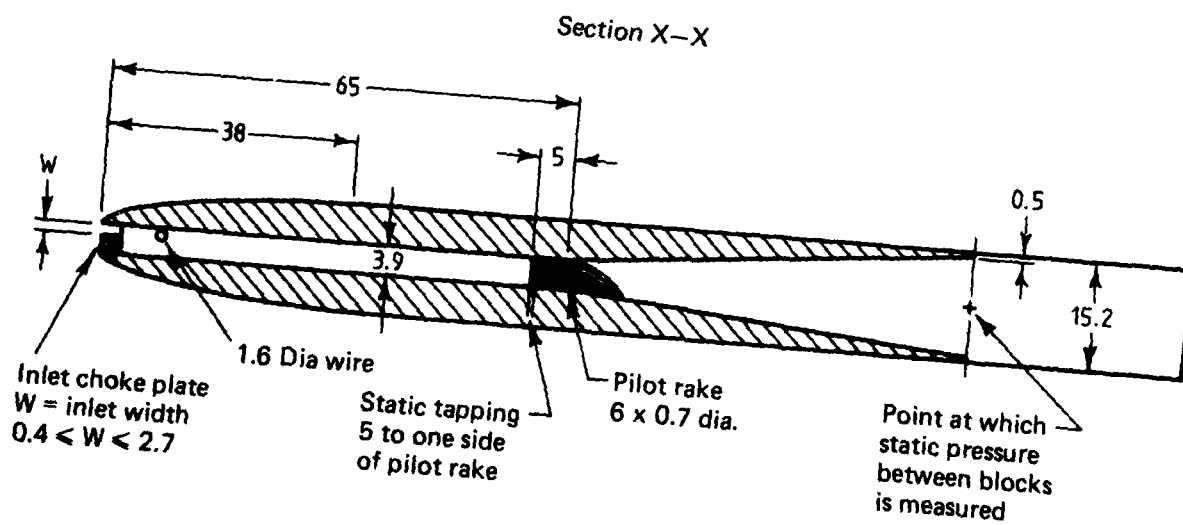
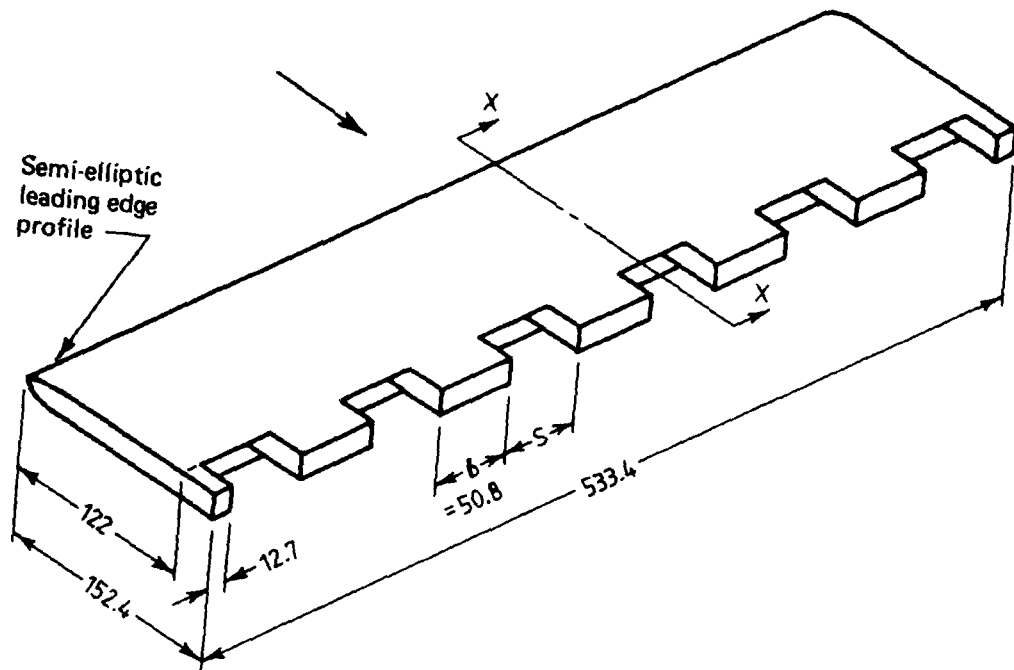

Note: all dimensions in mm

FIG. 1 DETAILS OF MODEL

- + Pressure tapping
- × Point at which pressure can be inferred from considerations of symmetry.

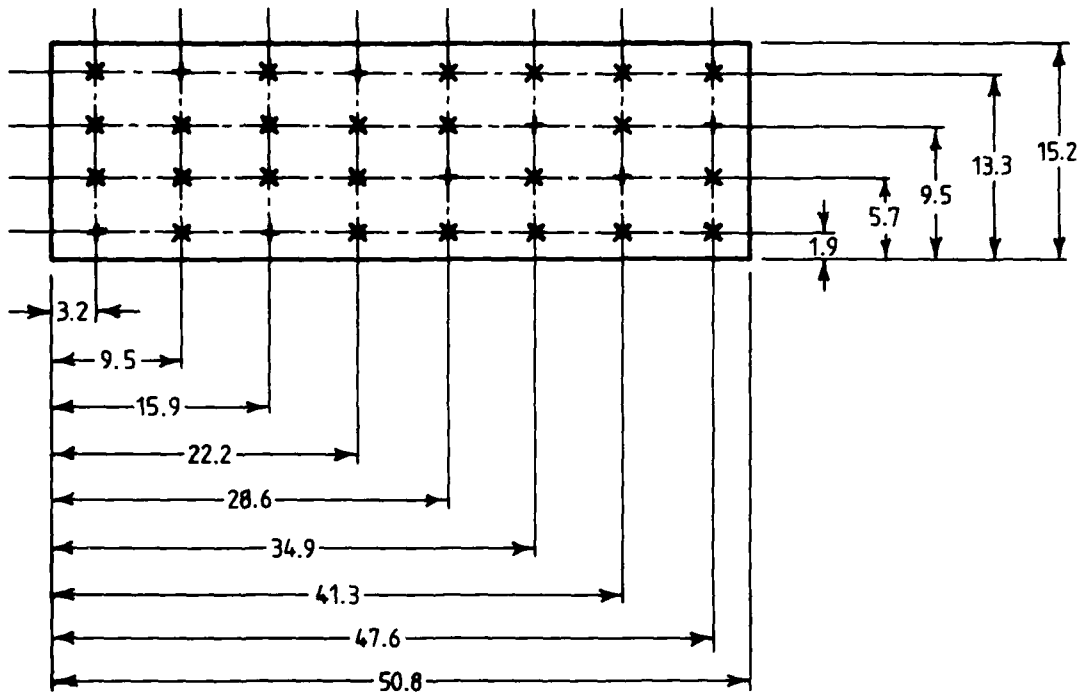

FIG. 2 LOCATION OF PRESSURE TAPPINGS IN BASE OF BLOCK

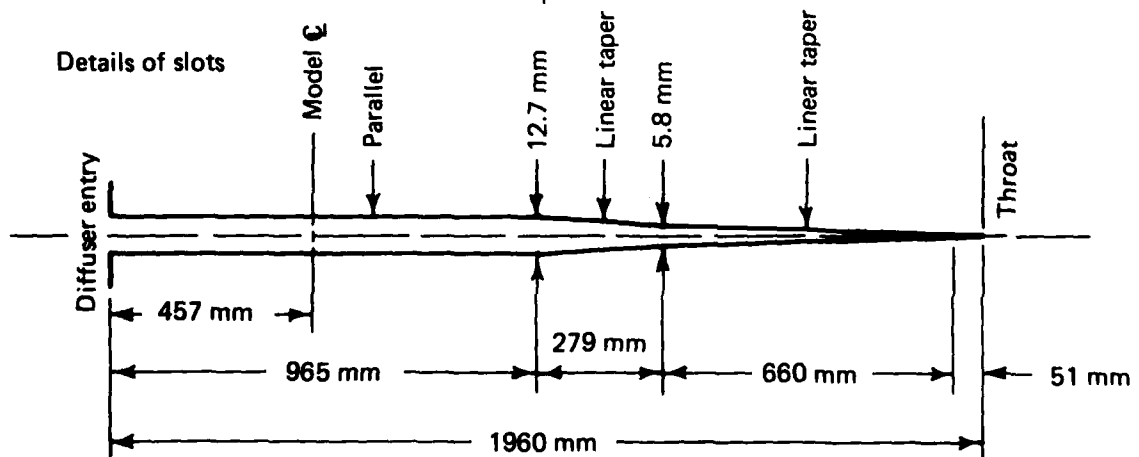
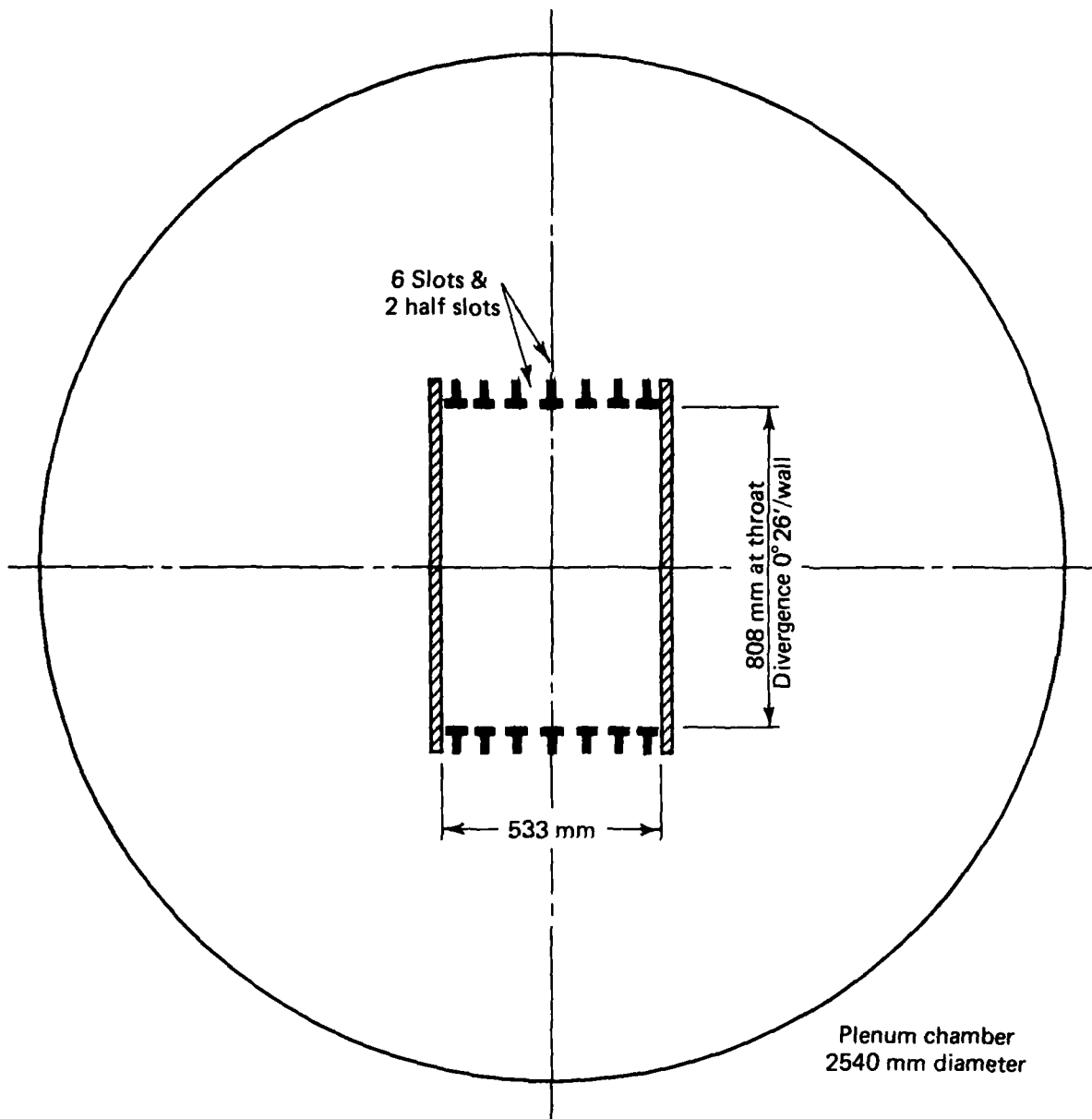

FIG. 3 DETAILS OF SLOTTED WORKING SECTION

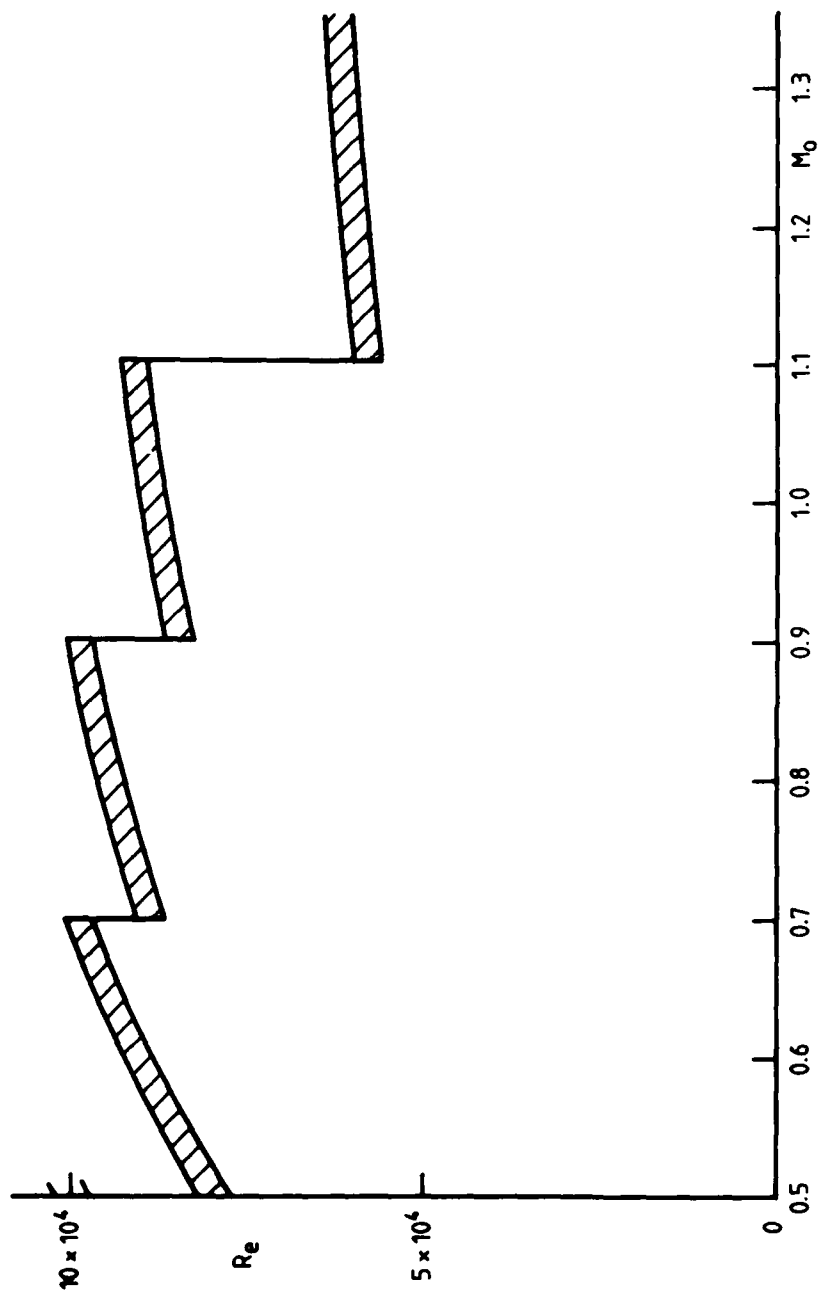

FIG. 4 VARIATION OF TEST REYNOLDS NUMBER WITH MACH NUMBER

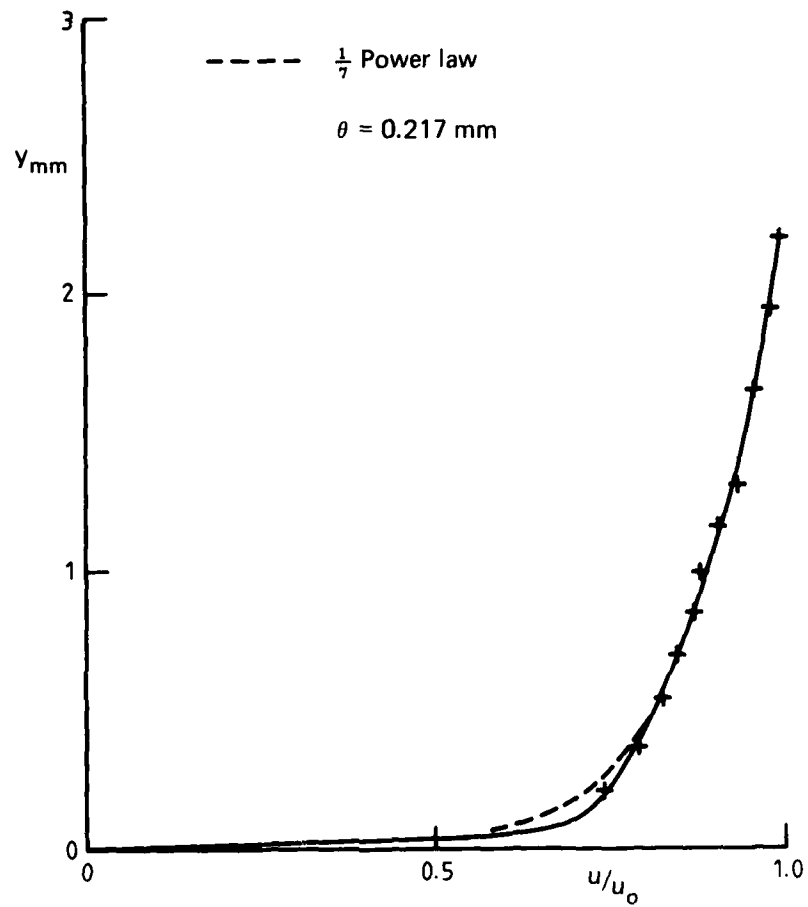

FIG. 5 BOUNDARY LAYER PROFILE AT BASE ( $M_0 = 0.50$ ,  $C_q = 0.025$ ,  $b/h = 0$ )

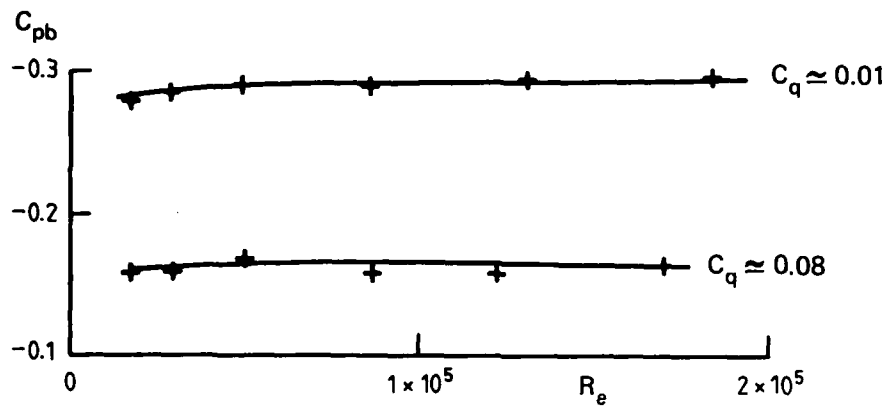

FIG. 6 VARIATION OF MEAN BASE PRESSURE WITH REYNOLDS NUMBER  
 ( $M_o = 0.6$ ,  $b/s = 1.20$ )

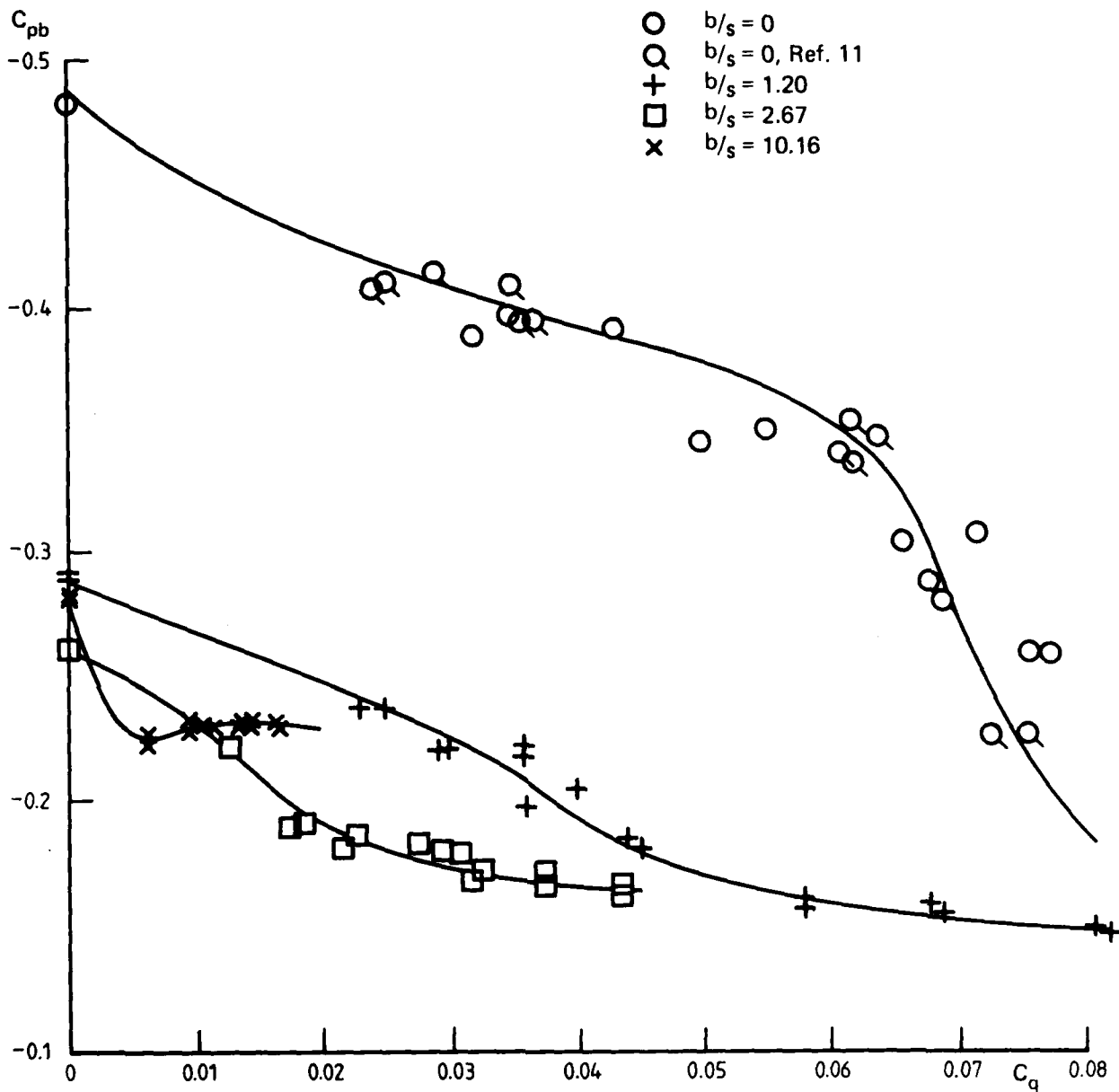

FIG. 7 VARIATION OF MEAN BASE PRESSURE WITH BLEED MASS FLOW  
 $M_o = 0.5$

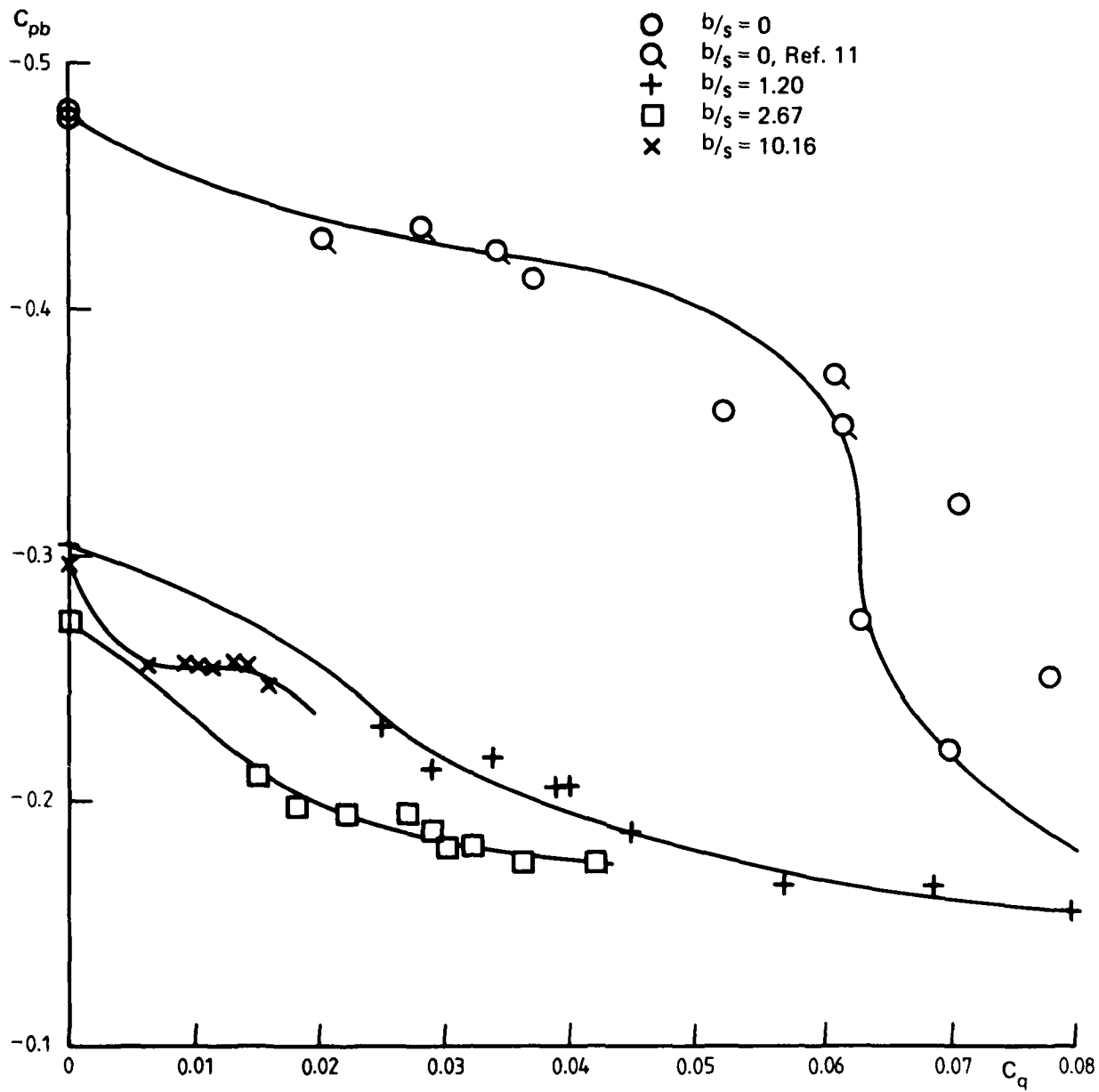

FIG. 8 VARIATION OF MEAN BASE PRESSURE WITH BLEED MASS FLOW  
 $M_o = 0.6$

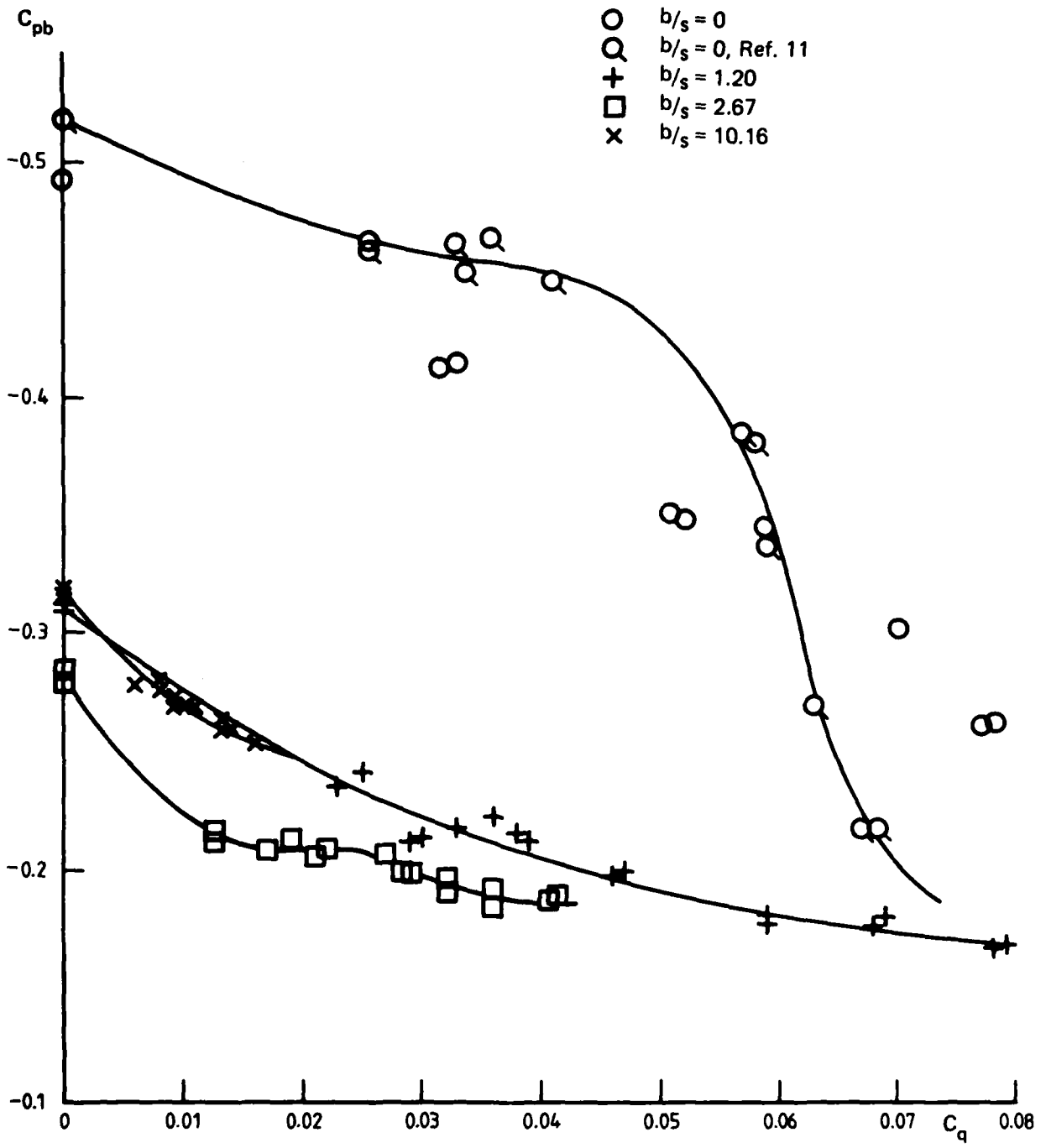

FIG. 9 VARIATION OF MEAN BASE PRESSURE WITH BLEED MASS FLOW  
 $M_o = 0.7$

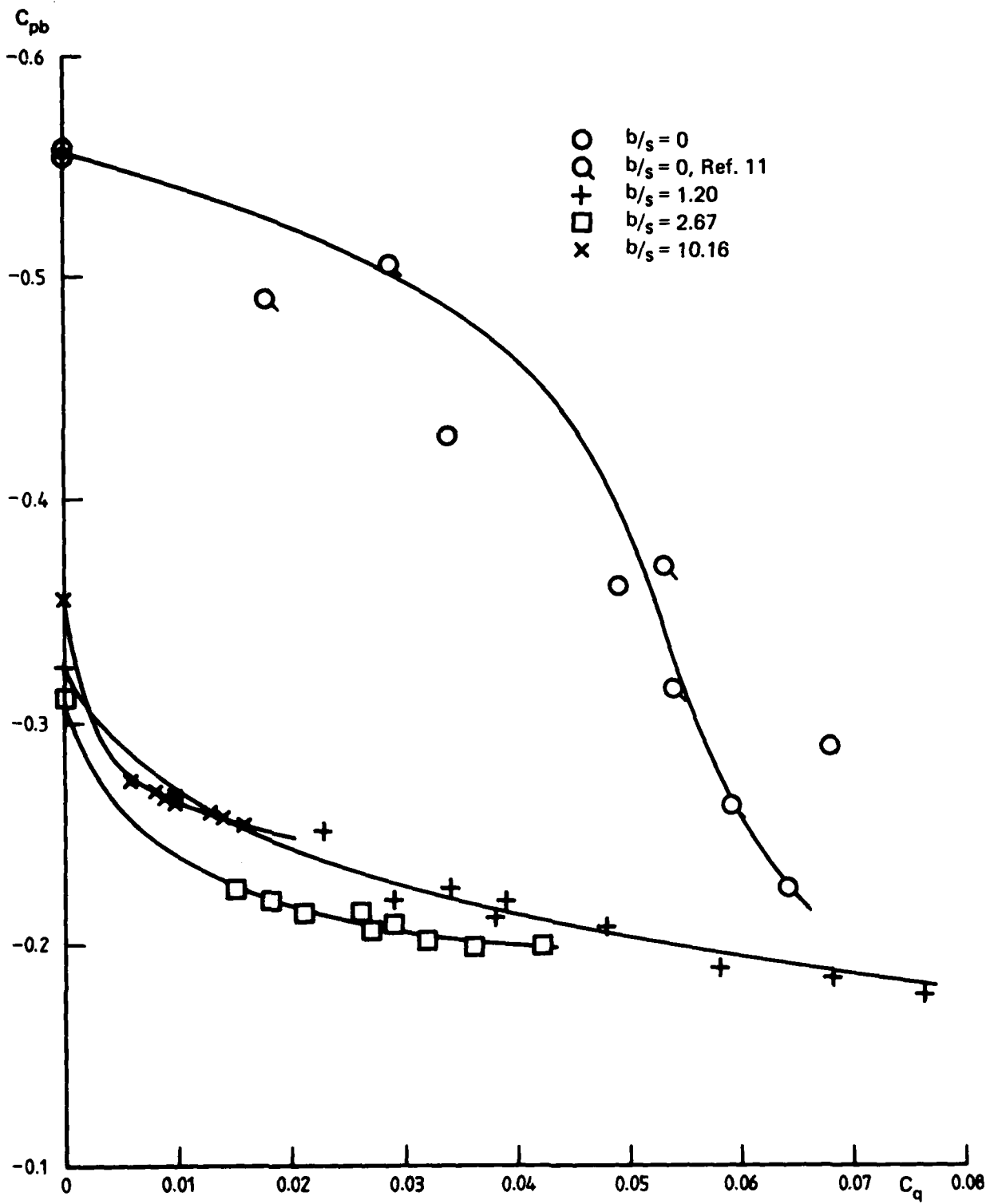

FIG. 10 VARIATION OF MEAN BASE PRESSURE WITH BLEED MASS FLOW  
 $M_0 = 0.8$

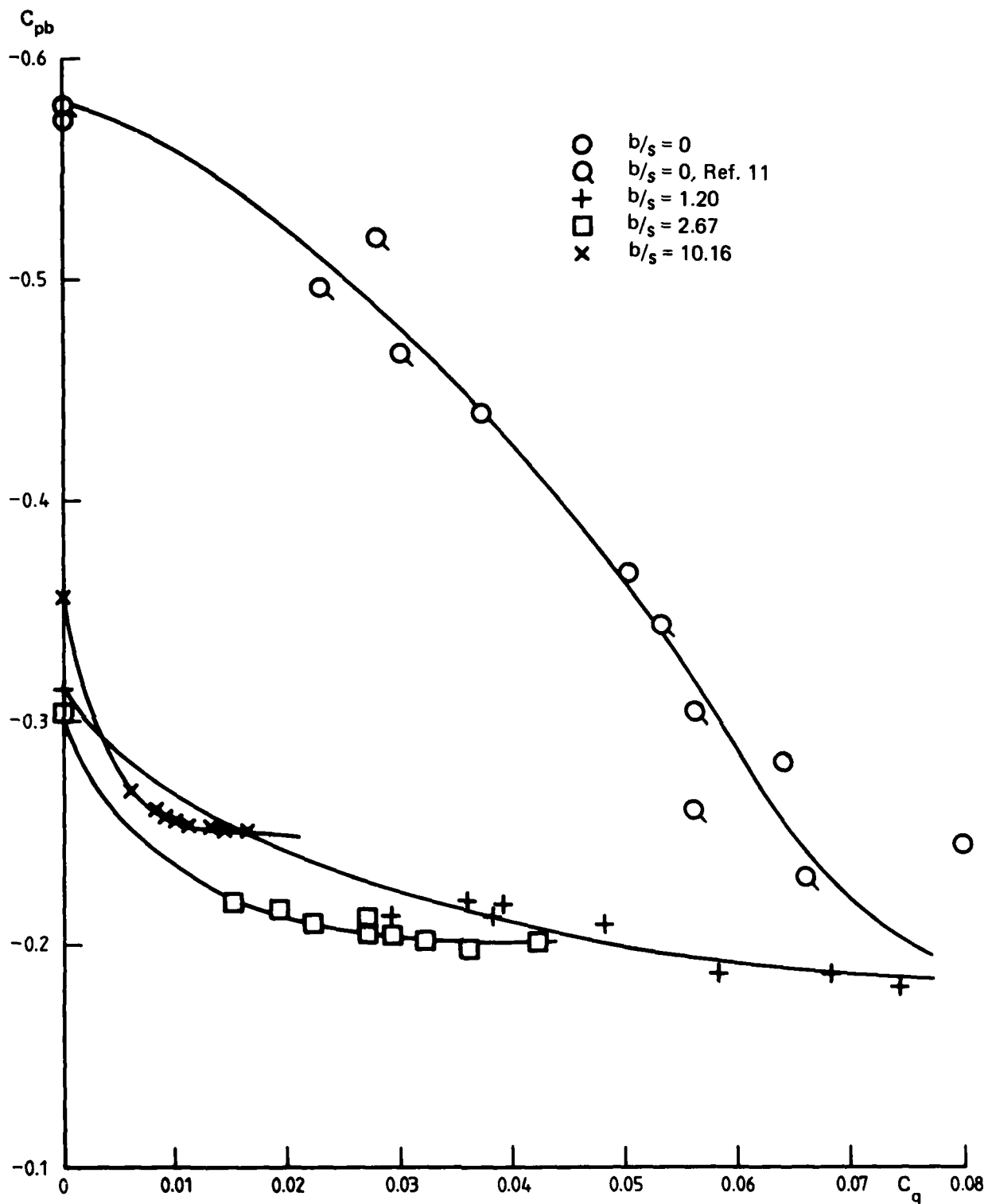

FIG. 11 VARIATION OF MEAN BASE PRESSURE WITH BLEED MASS FLOW  
 $M_o = 0.85$

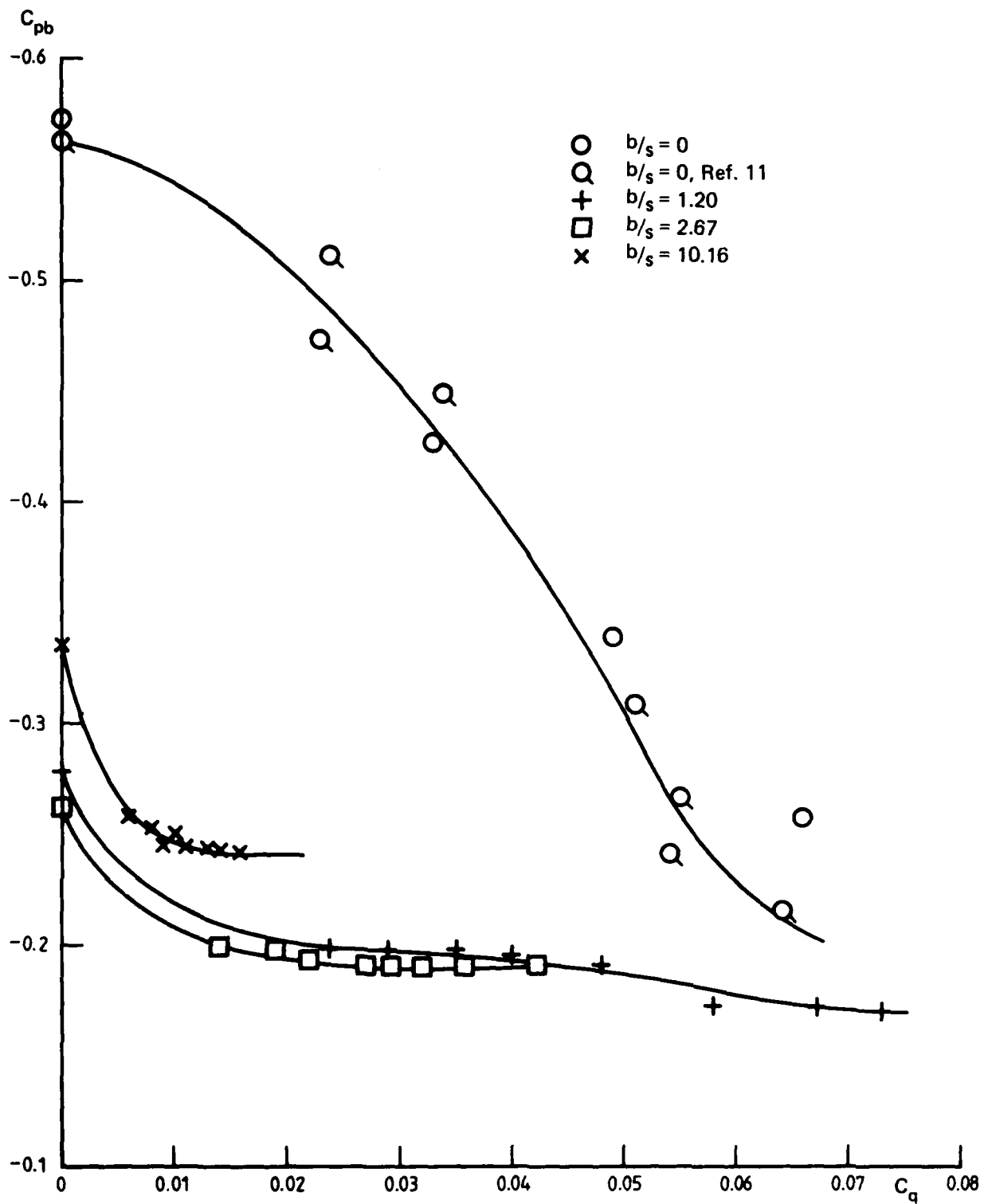

FIG. 12 VARIATION OF MEAN BASE PRESSURE WITH BLEED MASS FLOW  
 $M_0 = 0.875$

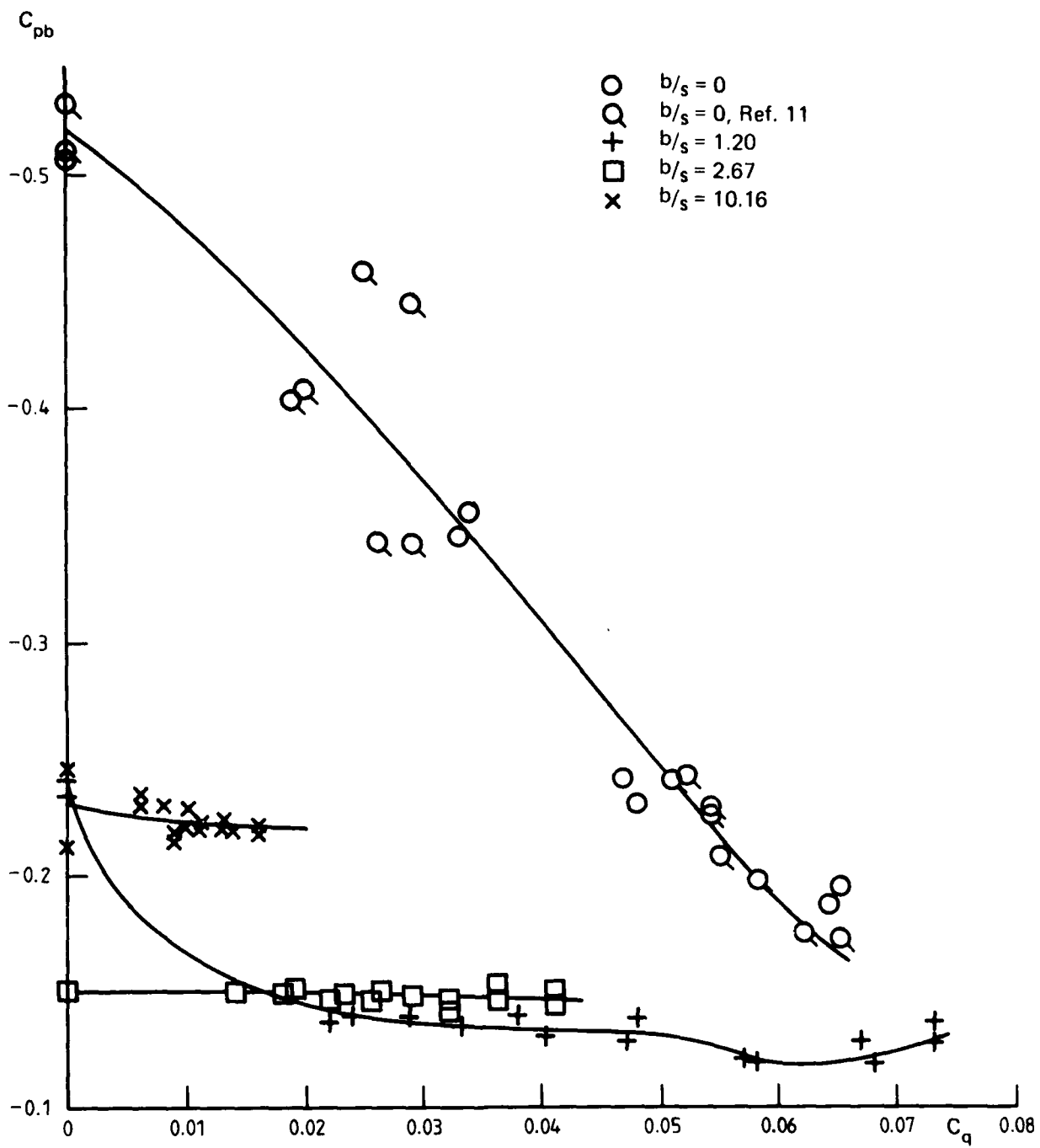

FIG. 13 VARIATION OF MEAN BASE PRESSURE WITH BLEED MASS FLOW  
 $M_0 = 0.9$

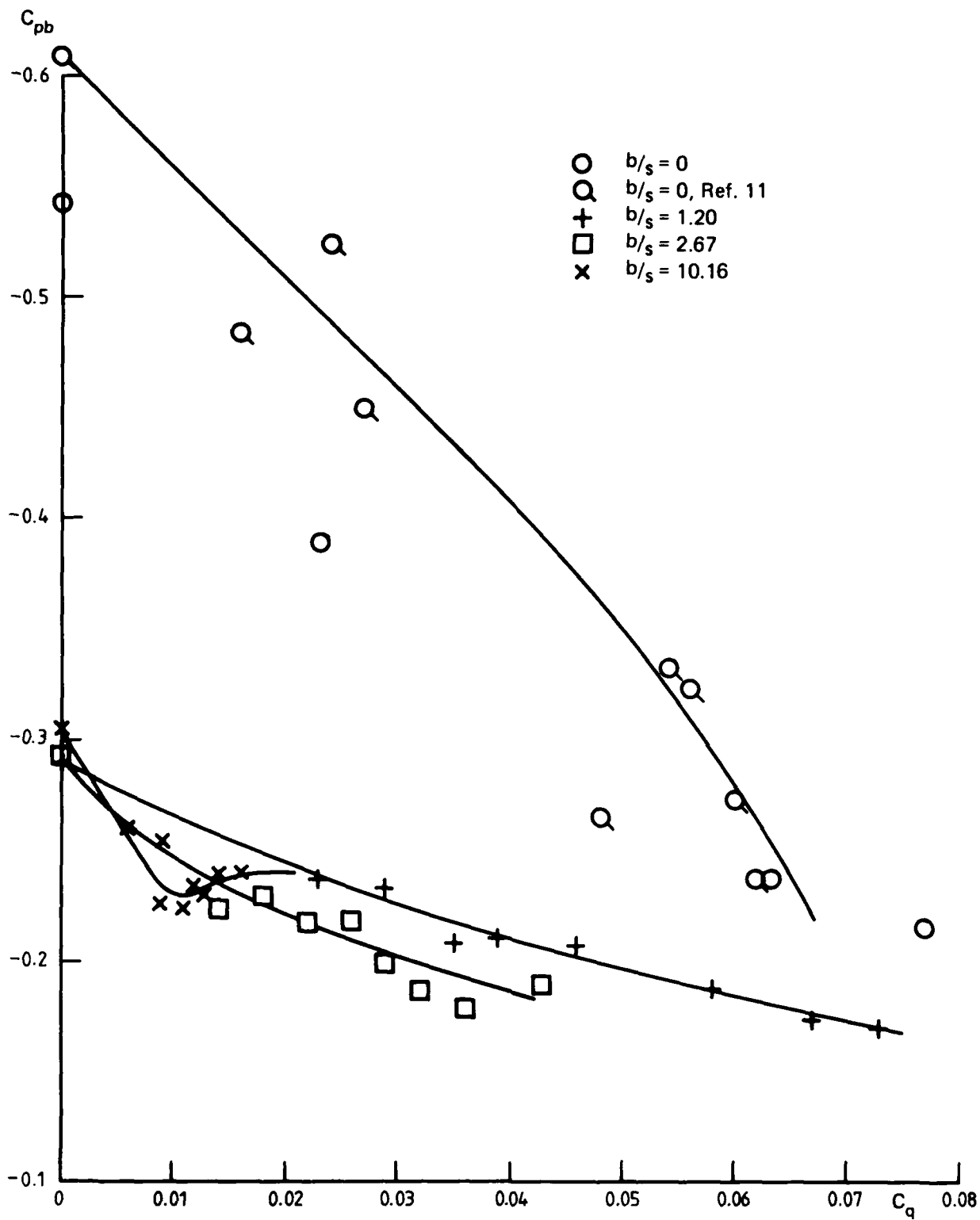

FIG. 14 VARIATION OF MEAN BASE PRESSURE WITH BLEED MASS FLOW  
 $M_o = 0.925$

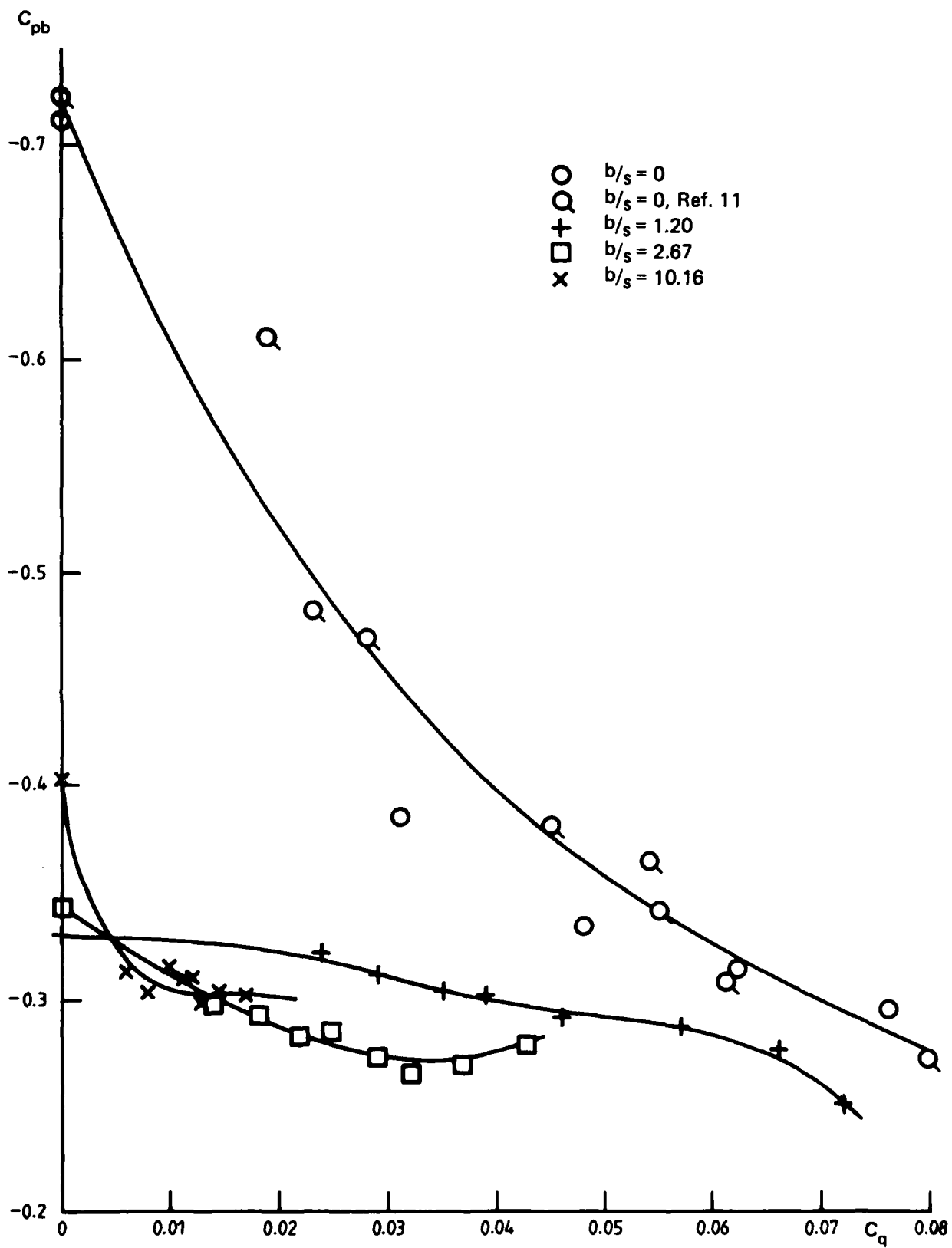

FIG. 15 VARIATION OF MEAN BASE PRESSURE WITH BLEED MASS FLOW  
 $M_o = 0.95$

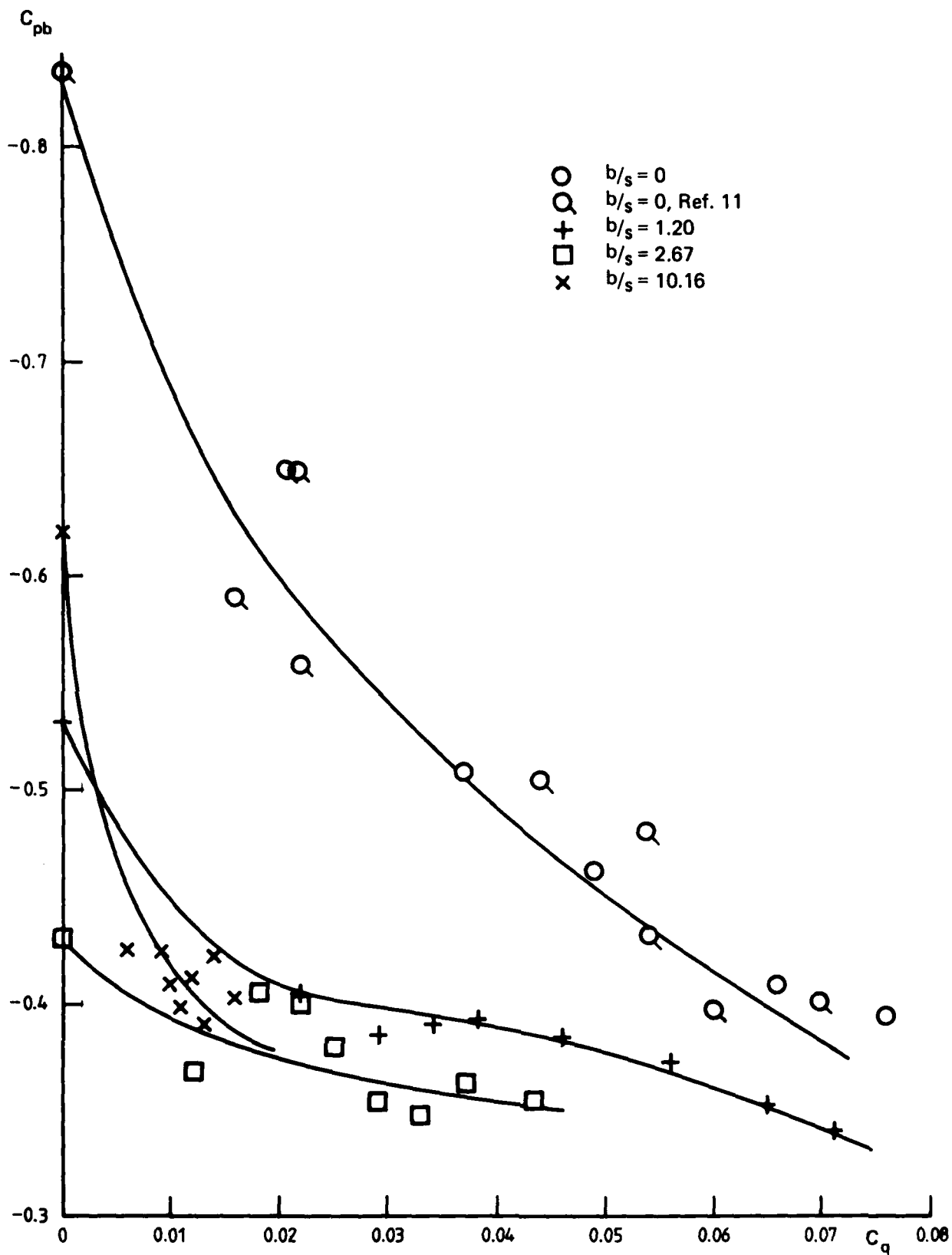

FIG. 16 VARIATION OF MEAN BASE PRESSURE WITH BLEED MASS FLOW  
 $M_0 = 0.975$

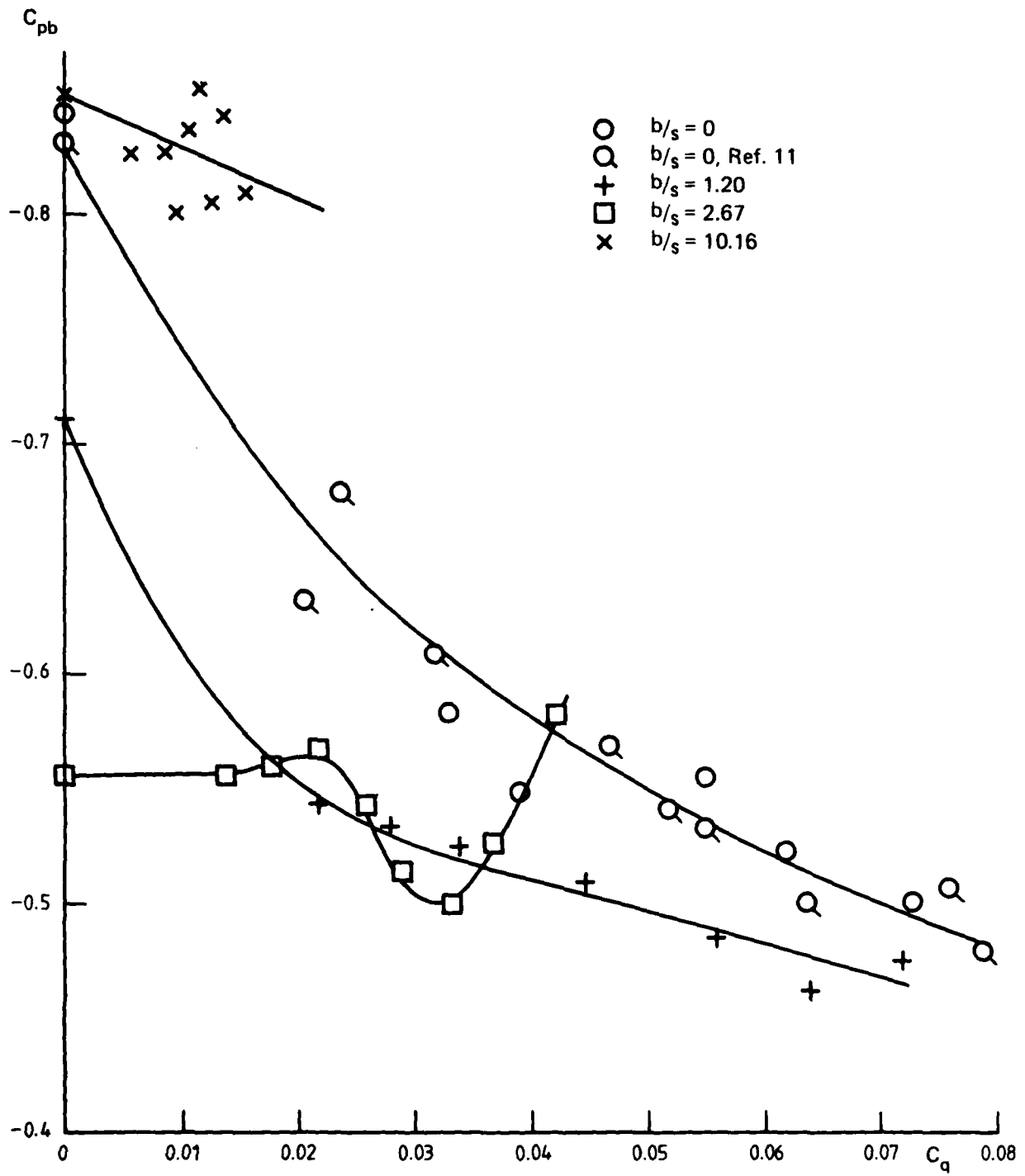

FIG. 17 VARIATION OF MEAN BASE PRESSURE WITH BLEED MASS FLOW  
 $M_o = 1.0$

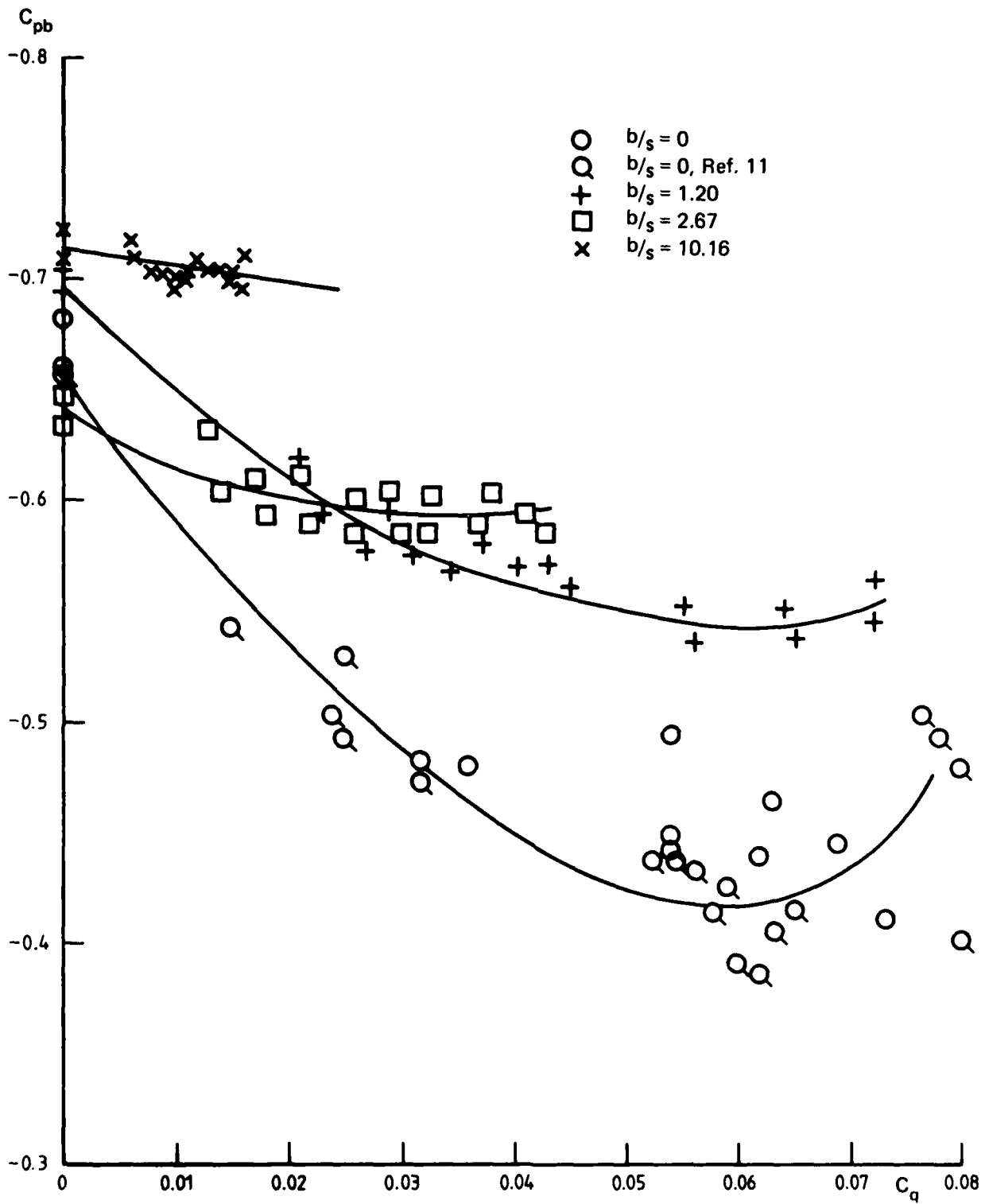

FIG. 18 VARIATION OF MEAN BASE PRESSURE WITH BLEED MASS FLOW  
 $M_o = 1.1$

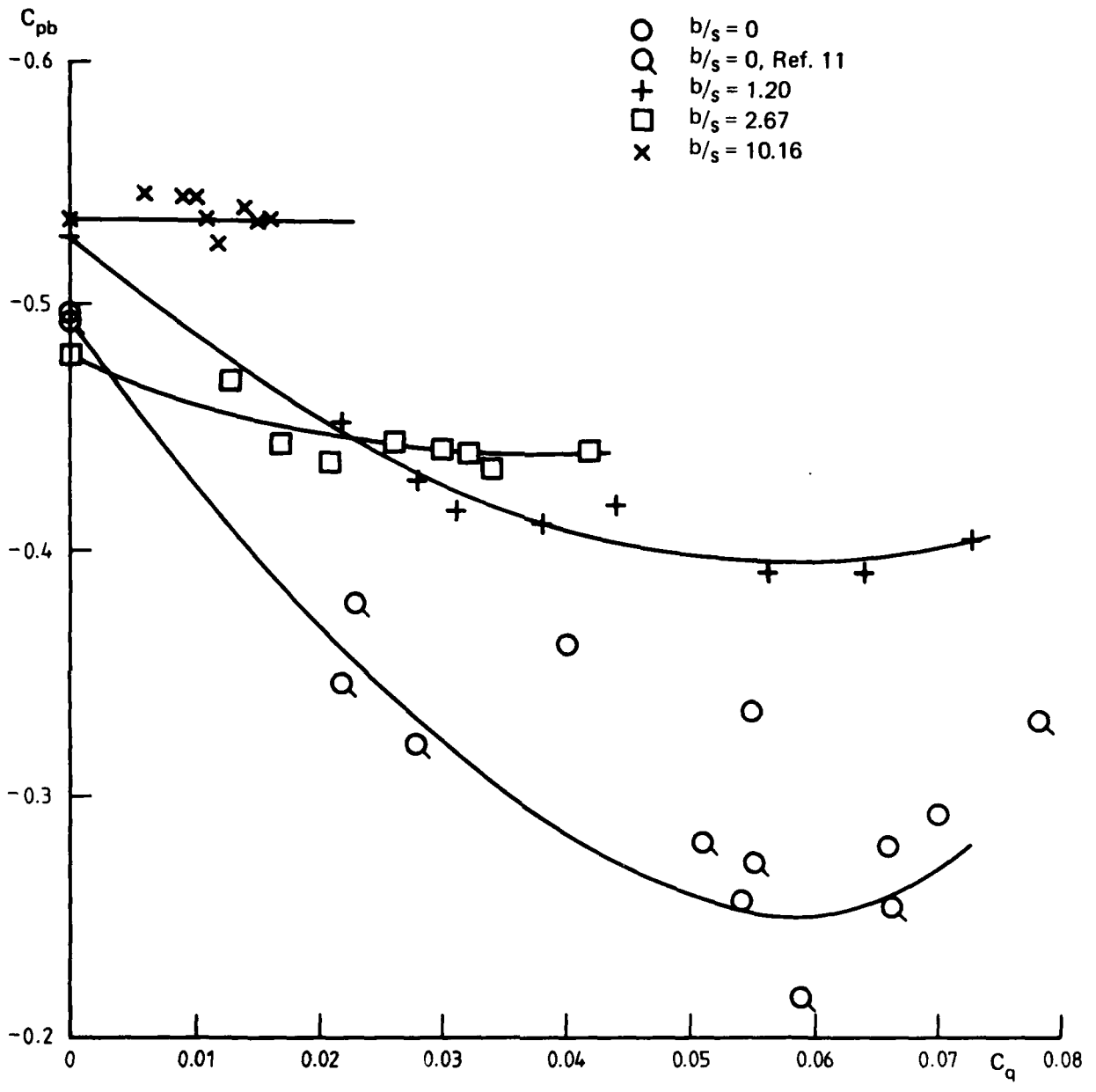

FIG. 19 VARIATION OF MEAN BASE PRESSURE WITH BLEED MASS FLOW  
 $M_o = 1.2$

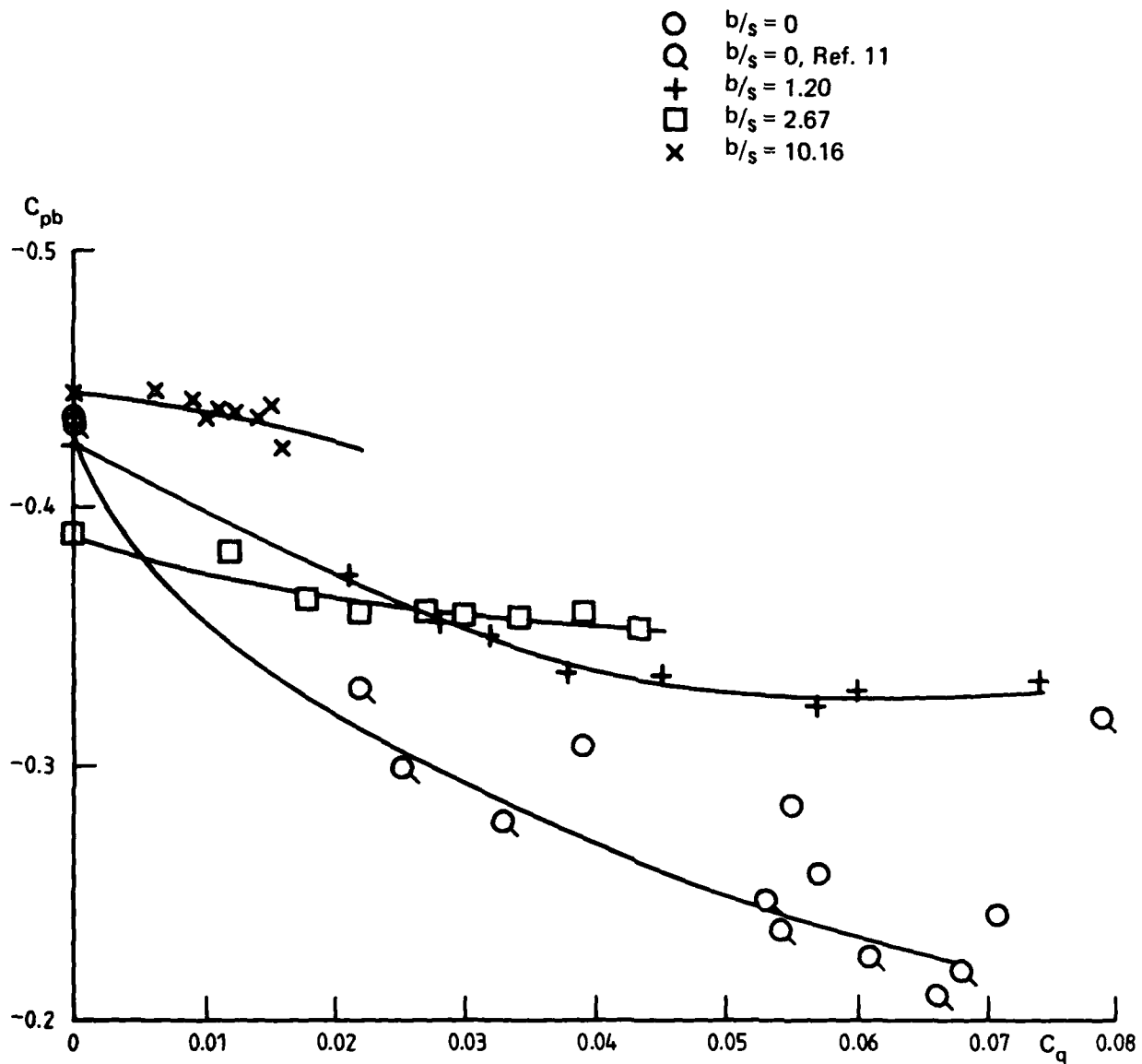

FIG. 20 VARIATION OF MEAN BASE PRESSURE WITH BLEED MASS FLOW  
 $M_o = 1.3$

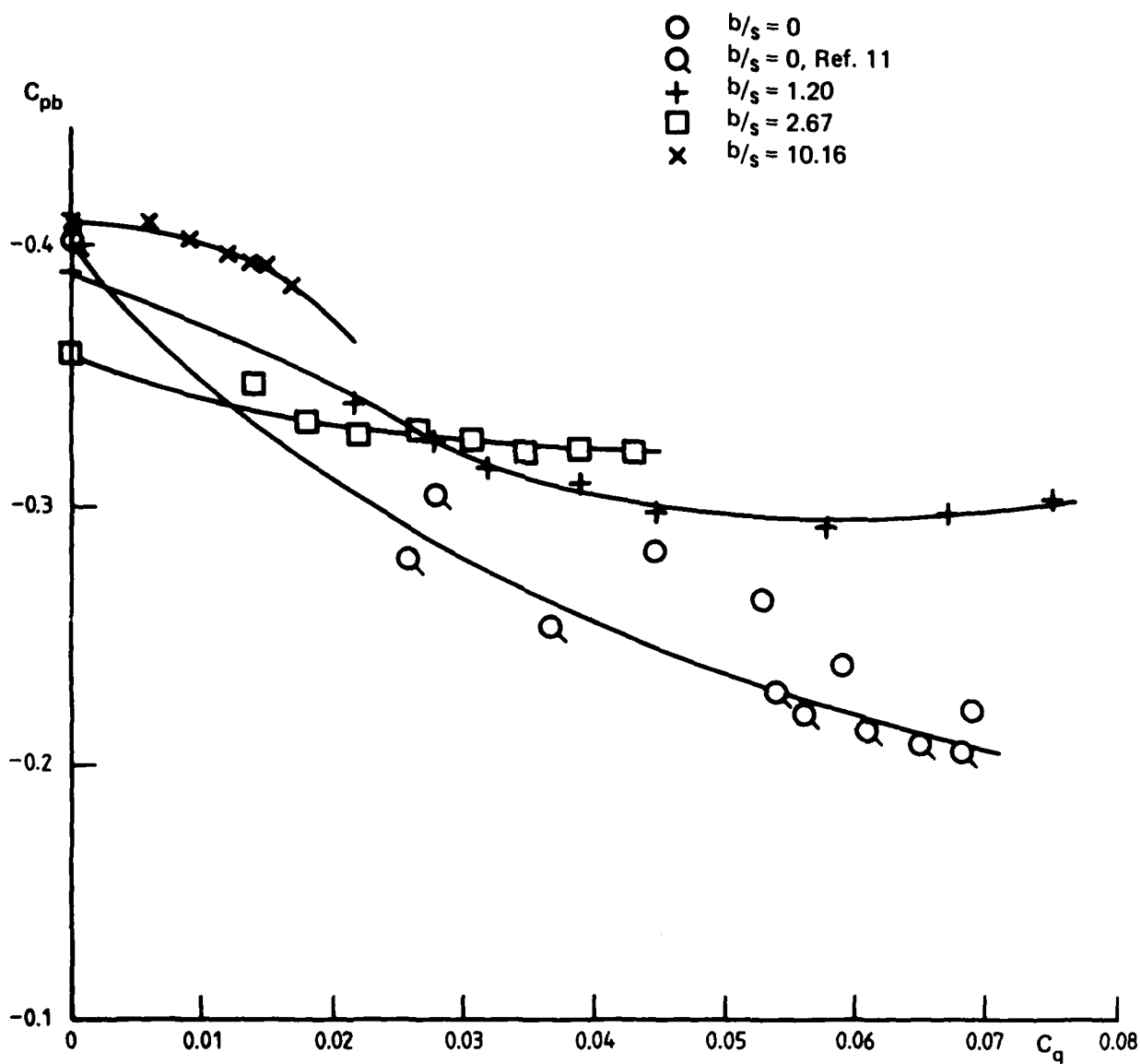

FIG. 21 VARIATION OF MEAN BASE PRESSURE WITH BLEED MASS FLOW  
 $M_0 = 1.35$

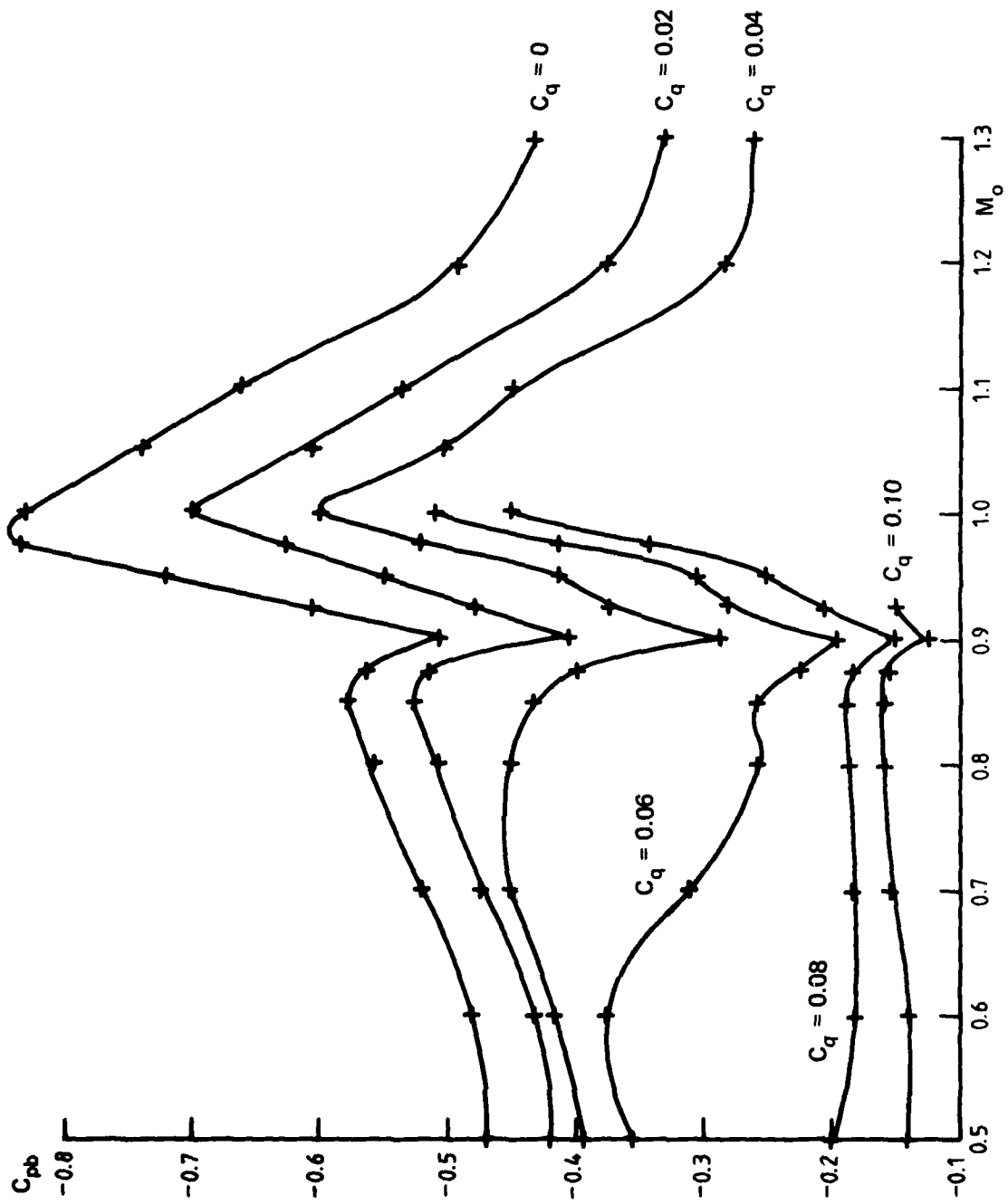

FIG. 22 VARIATION OF MEAN BASE PRESSURE WITH MACH NUMBER  
( $b/s = 0$ )

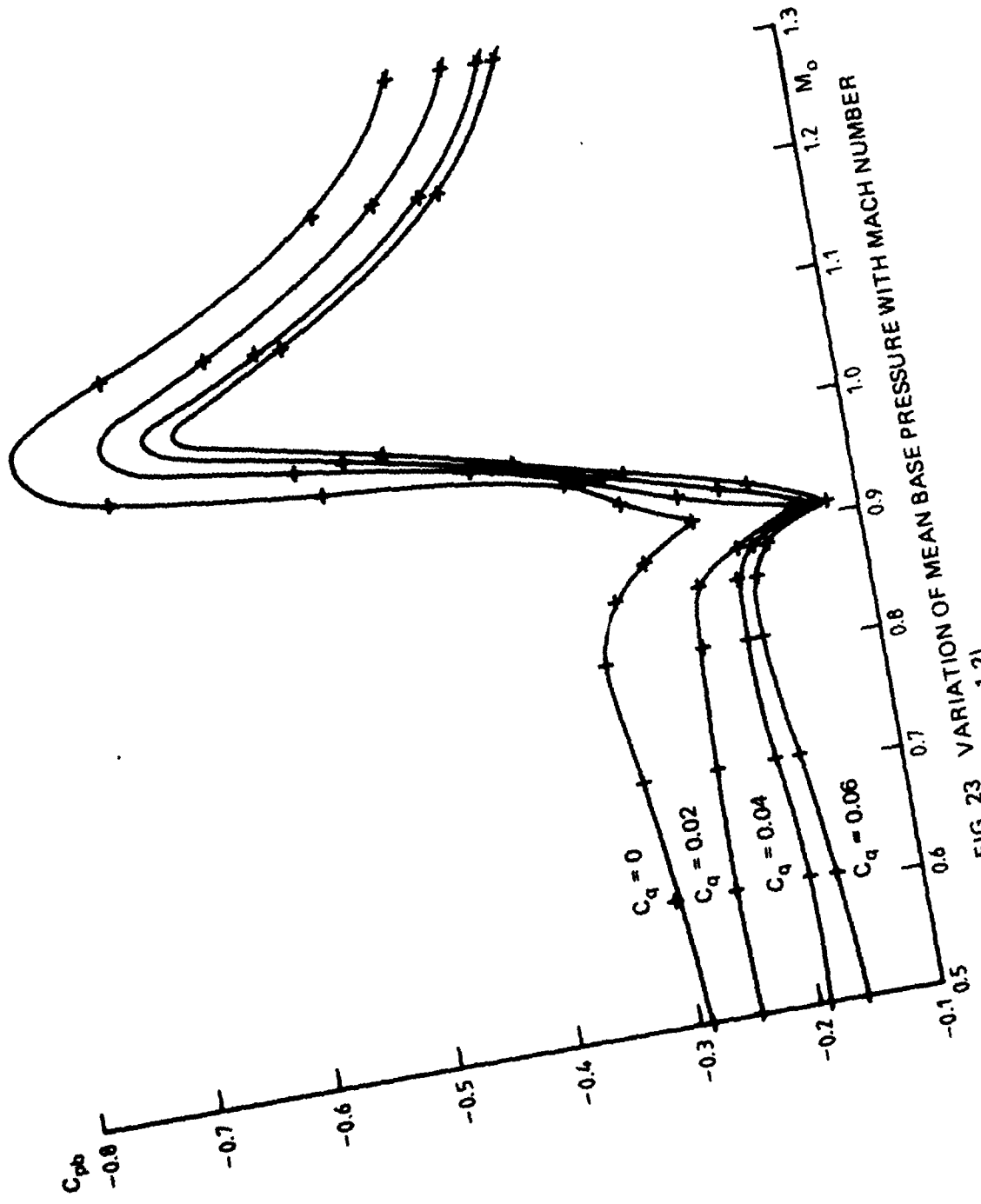

FIG. 23 VARIATION OF MEAN BASE PRESSURE WITH MACH NUMBER  
( $b/s = 1.2$ )

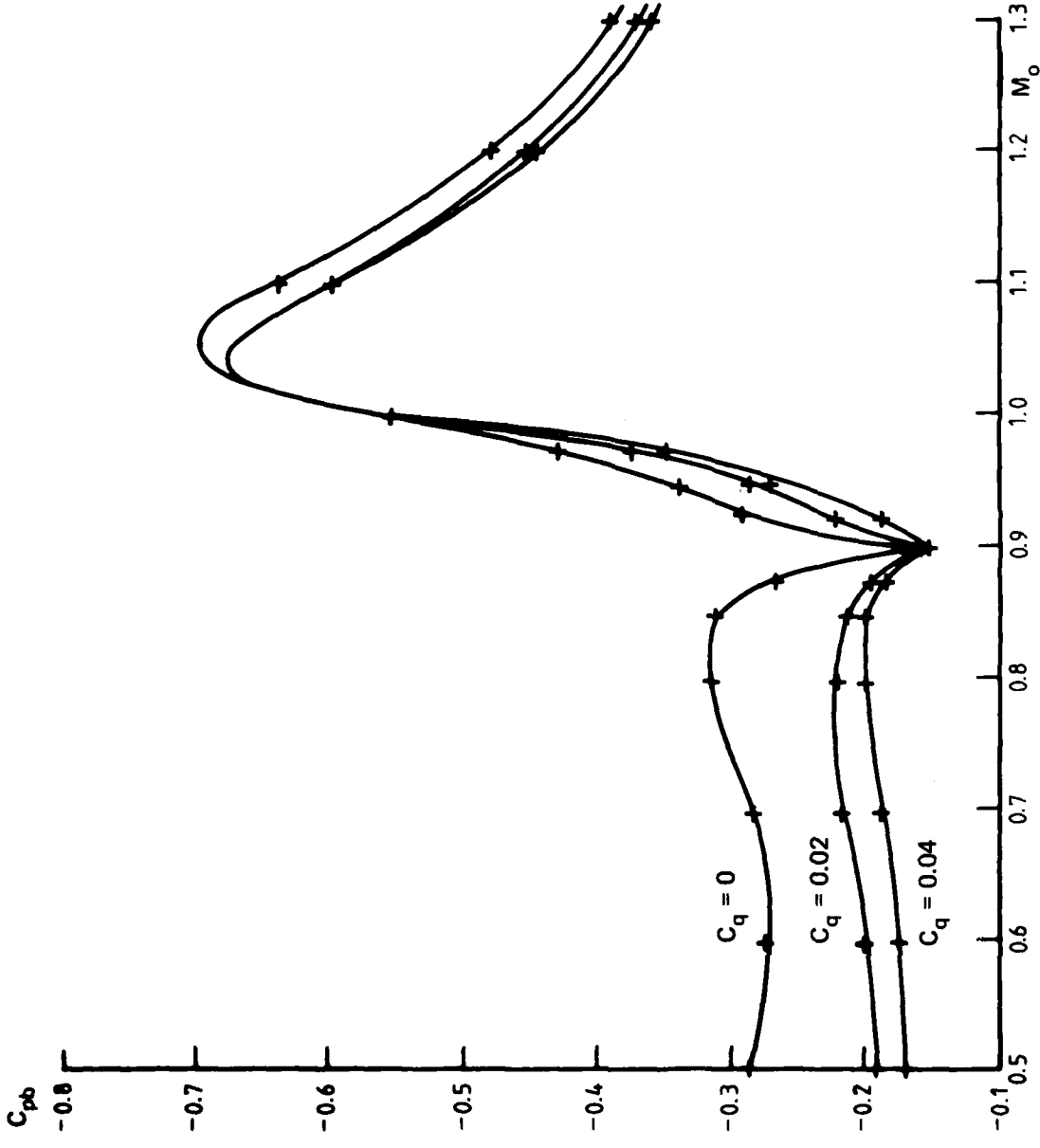

FIG. 24 VARIATION OF MEAN BASE PRESSURE WITH MACH NUMBER  
( $b/s = 2.67$ )

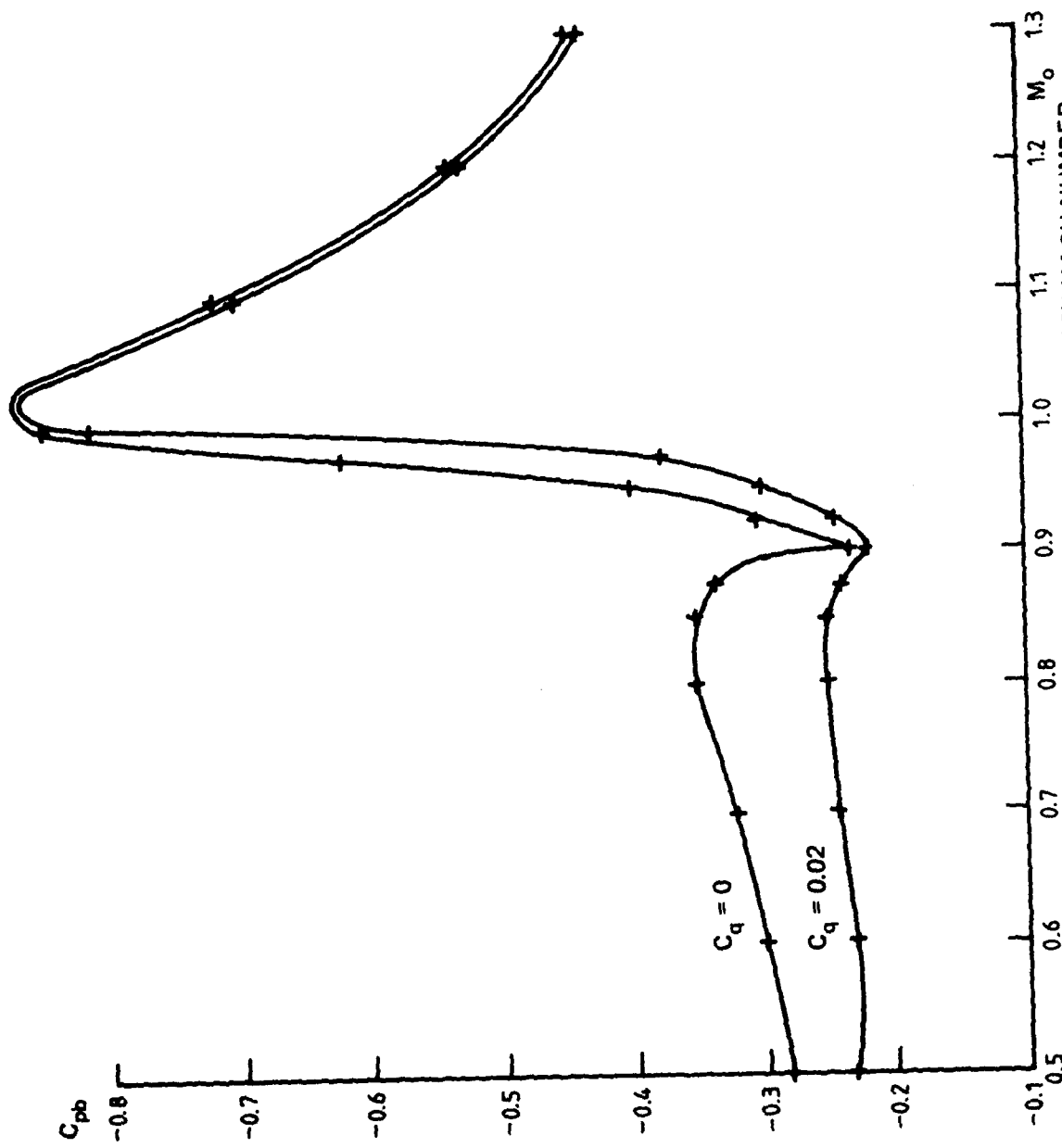

FIG. 25 VARIATION OF MEAN BASE PRESSURE WITH MACH NUMBER  
( $b/s = 10.16$ )

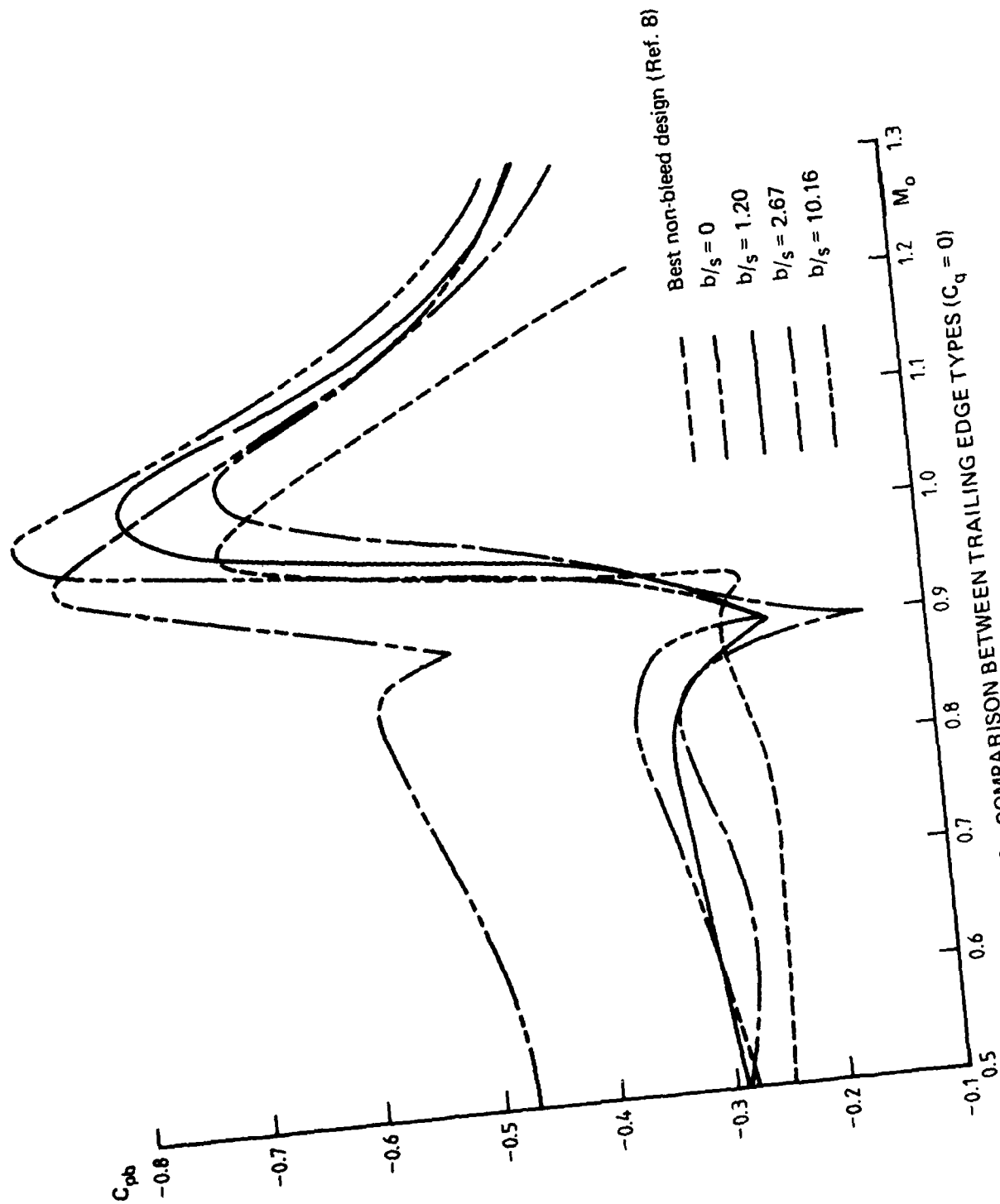

FIG. 26 COMPARISON BETWEEN TRAILING EDGE TYPES ( $C_q = 0$ )

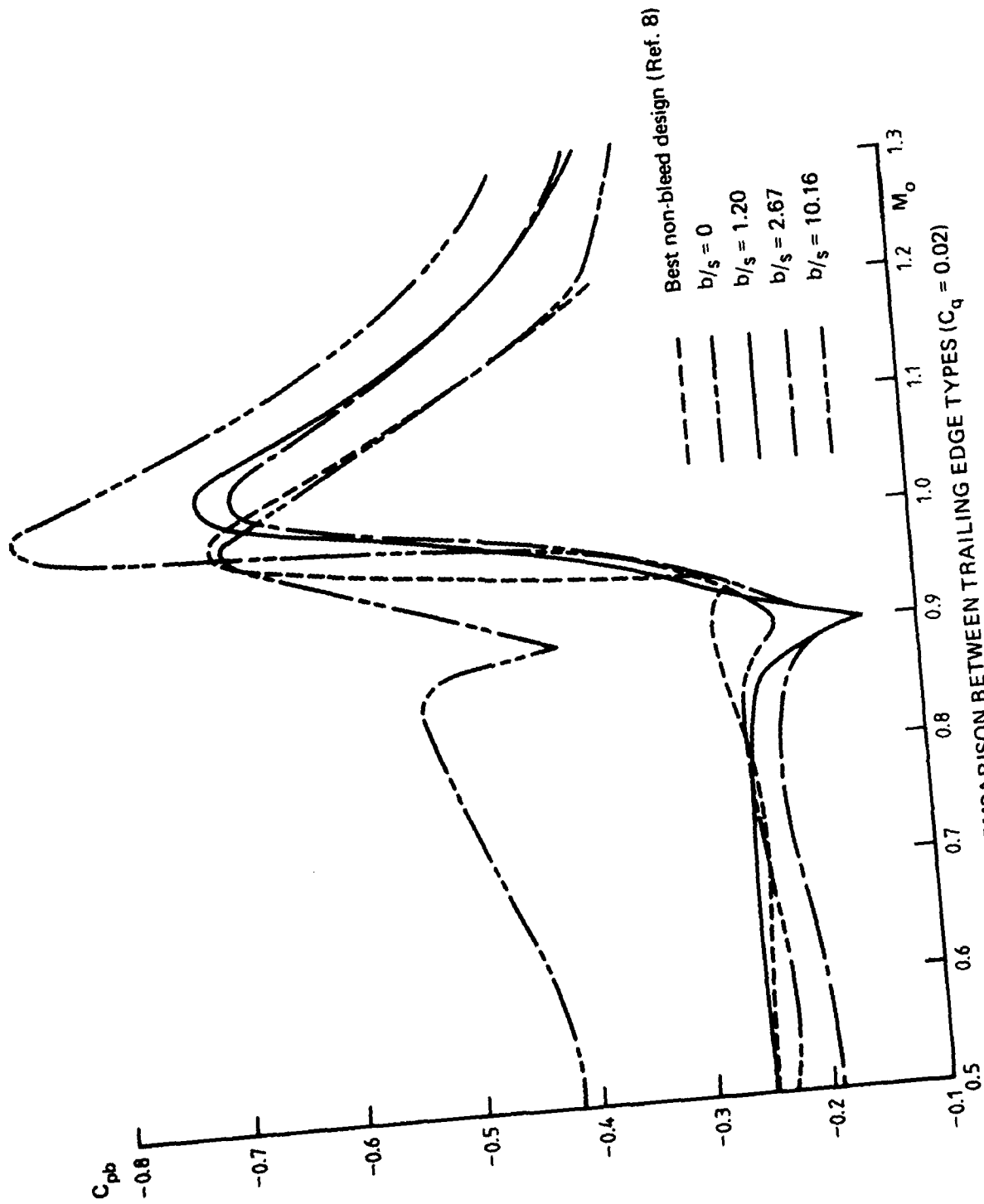

FIG. 27 COMPARISON BETWEEN TRAILING EDGE TYPES ( $C_q = 0.02$ )

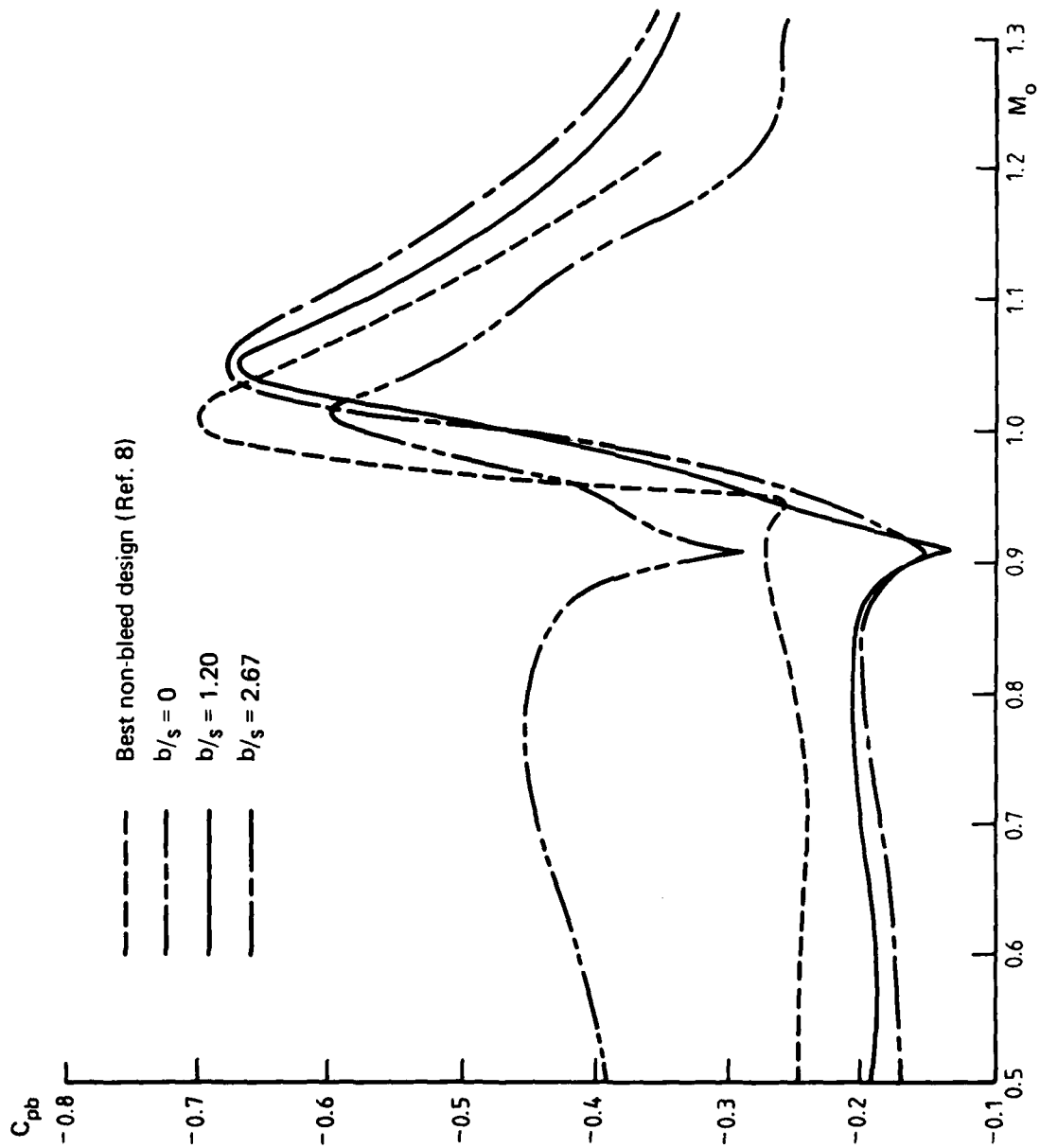

FIG. 28 COMPARISON BETWEEN TRAILING EDGE TYPES ( $C_q = 0.04$ )

**DISTRIBUTION**

**AUSTRALIA**

**DEPARTMENT OF DEFENCE**

**Central Office**

Chief Defence Scientist  
Deputy Chief Defence Scientist  
Superintendent, Science and Technology Programmes  
Controller, Projects and Analytical Studies  
Defence Science Representative (U.K.) (Doc. Data sheet only)  
Counsellor, Defence Science (U.S.A.) (Doc. Data sheet only)  
Defence Central Library  
Document Exchange Centre, D.I.S.B. (17 copies)  
Librarian H Block, Victoria Barracks, Melbourne  
Director General—Army Development (NSO) (4 copies)

} (1 copy)

**Aeronautical Research Laboratories**

Director  
Library  
Superintendent—Aerodynamics  
Divisional File—Aerodynamics  
Author: N. Pollock  
Wind Tunnel Research Group (4 copies)

**Materials Research Laboratories**

Director/Library

**Defence Research Centre**

Library

**Navy Office**

Navy Scientific Adviser  
RAN Aircraft Maintenance and Flight Trials Unit  
Directorate of Naval Aircraft Engineering  
Directorate of Naval Ship Design

**Army Office**

Army Scientific Adviser  
Engineering Development Establishment, Library  
Royal Military College Library  
US Army Research, Development and Standardisation Group

**Air Force Office**

Air Force Scientific Adviser  
Aircraft Research and Development Unit  
Scientific Flight Group  
Library

Technical Division Library  
Director General Aircraft Engineering—Air Force  
HQ Support Command (SENGSO)  
RAAF Academy, Point Cook

Central Studies Establishment  
Information Centre

#### DEPARTMENT OF DEFENCE SUPPORT

Government Aircraft Factories  
Manager  
Library

#### DEPARTMENT OF SCIENCE AND TECHNOLOGY

Bureau of Meteorology, Library

#### DEPARTMENT OF AVIATION

Library

#### STATUTORY AND STATE AUTHORITIES AND INDUSTRY

Australian Atomic Energy Commission, Director  
SEC of Vic., Herman Research Laboratory, Library  
B.H.P., Melbourne Research Laboratories  
Commonwealth Aircraft Corporation, Library  
Hawker de Havilland Aust. Pty. Ltd., Bankstown, Library  
Rolls Royce of Australia Pty. Ltd., Mr C. G. A. Bailey

#### UNIVERSITIES AND COLLEGES

Adelaide	Barr Smith Library Professor of Mechanical Engineering
Flinders	Library
Latrobe	Library
Melbourne	Engineering Library
Monash	Hargrave Library
Newcastle	Library
Sydney	Engineering Library
N.S.W.	Physical Sciences Library Professor R. A. A. Bryant, Mechanical Engineering
Queensland	Library
Tasmania	Engineering Library
Western Australia	Library Associate Professor J. A. Cole, Mechanical Engineering
R.M.I.T.	Library Dr H. Kowalski, Mech. and Production Engineering Mr T. G. Hird, Mech. and Production Engineering

#### CANADA

NRC  
Aeronautical and Mechanical Engineering Library  
Division of Mechanical Engineering, Director  
Gas Dynamics Laboratory, Mr R. A. Tyler

**Universities and Colleges**

Toronto

Institute for Aerospace Studies

**FRANCE**

ONERA, Library

**GERMANY**

Fachinformationszentrum: Energie, Physik, Mathematik GMBH

**INDIA**

Defence Ministry, Aero Development Establishment, Library

Gas Turbine Research Establishment, Director

Hindustan Aeronautics Ltd, Library

National Aeronautical Laboratory, Information Centre

**ISRAEL**

Technion-Israel Institute of Technology

Professor J. Singer

**ITALY**

Professor Ing. Guiseppe Gabrielli

**JAPAN**

Institute of Space and Astronautical Science, Library

**NETHERLANDS**

National Aerospace Laboratory (NLR), Library

**NEW ZEALAND**

RNZAF, Vice Consul (Defence Liason)

**Universities**

Canterbury

Professor D. Stevenson, Mechanical Engineering

**SWEDEN**

Aeronautical Research Institute, Library

Swedish National Defense Research Institute (FOA)

**UNITED KINGDOM**

CAARC, Secretary (NPL)

Royal Aircraft Establishment

Bedford, Library

National Gas Turbine Establishment  
     Director, Pyestock North  
 National Physical Laboratory, Library  
 British Library, Lending Division  
 Aircraft Research Association, Library  
 British Ship Research Association  
 National Maritime Institute, Library  
 GEC Gas Turbines Ltd, Managing Director  
 Fulmer Research Institute Ltd, Research Director  
 Motor Industry Research Association, Director  
 Rolls-Royce Ltd  
     Aero Division Bristol, Library  
 British Aerospace  
     Kingston-upon-Thames, Library  
     Hatfield-Chester Division, Library  
 British Hovercraft Corporation Ltd, Library  
 Short Brothers Ltd, Technical Library

**Universities and Colleges**

Bristol	Engineering Library
Cambridge	Library, Engineering Department Whittle Library
London	Professor G. J. Hancock, Aero Engineering
Manchester	Professor, Applied Mathematics Professor N. Johannesen, Fluid Mechanics
Nottingham	Science Library
Southampton	Library
Liverpool	Fluid Mechanics Division, Dr J. C. Gibbings
Strathclyde	Library
Cranfield Institute of Technology	Library
Imperial College	Aeronautics Library

**UNITED STATES OF AMERICA**

NASA Scientific and Technical Information Facility  
 Applied Mechanics Reviews  
 The John Crerar Library  
 Allis Chalmers Corporation, Library  
 Kentex Research Library  
 United Technologies Corporation, Library  
 Lockheed-California Company  
 Lockheed Missiles and Space Company  
 Lockheed Georgia  
 McDonnell Aircraft Company, Library

**Universities and Colleges**

Johns Hopkins	Professor S. Corrsin, Engineering
Princeton	Professor G. L. Mellor, Mechanics
Massachusetts Inst. of Technology	M.I.T. Libraries

**SPARES (10 copies)**

**TOTAL (143 copies)**

Department of Defence Support  
**DOCUMENT CONTROL DATA**

1. a. AR No. AR-002-967	1. b. Establishment No. ARL-AERO-NOTE-418	2. Document Date July, 1983	3. Task No. 82/023
4. Title THE EFFECT OF DISCRETE SPANWISE REGIONS OF BLEED ON TWO-DIMENSIONAL BASE FLOW AT TRANSONIC SPEEDS		5. Security a. document Unclassified	6. No. Pages 9
		b. title      c. abstract U              U	7. No. Refs 20
8. Author(s) N. Pollock		9. Downgrading Instructions —	
10. Corporate Author and Address Aeronautical Research Laboratories  P.O. Box 4331, MELBOURNE, VIC., 3001		11. Authority (as appropriate) a. Sponsor                      c. Downgrading b. Security                      d. Approval —	
12. Secondary Distribution (of this document) Approved for public release			
Overseas enquirers outside stated limitations should be referred through ASDIS, Defence Information Services Branch, Department of Defence, Campbell Park, CANBERRA, ACT, 2601.			
13. a. This document may be ANNOUNCED in catalogues and awareness services available to . . . No limitations			
13. b. Citation for other purposes (i.e. casual announcement) may be (select) unrestricted (or) as for 13 a.			
14. Descriptors Aerodynamic drag Base flow Transonic airfoils Wakes Wind tunnel models		15. COSATI Group 0101 2004	
16. Abstract <i>A preliminary experimental study of a new type of pseudo-two-dimensional bluff base consisting of a series of rectangular prismatic protrusions spaced along the span with base bleed into the regions between the protrusions is presented.</i> <i>A base geometry was derived which had less drag at subsonic and transonic speeds than the best reported non-bleed arrangement for bleed mass flow coefficients (based on the mass flux swept by the model frontal area) in the range 0.02 to 0.04. A simple two-dimensional bleed arrangement requires a bleed coefficient greater than 0.08 to achieve the same subsonic base drag.</i>			

This page is to be used to record information which is required by the Establishment for its own use but which will not be added to the DISTIS data base unless specifically requested.

16. Abstract (Contd)		
17. Imprint Aeronautical Research Laboratories, Melbourne		
18. Document Series and Number Aerodynamics Note 418	19. Cost Code 547710	20. Type of Report and Period Covered —
21. Computer Programs Used —		
22. Establishment File Ref(s) —		

ED  
8