

AD-A139 605

ISSUES SURROUNDING AN OIL IMPORT PREMIUM(U) RAND CORP
SANTA MONICA CA C E PHELPS ET AL. SEP 83 RAND/P-6903

1/1

UNCLASSIFIED

F/G 5/3

NL

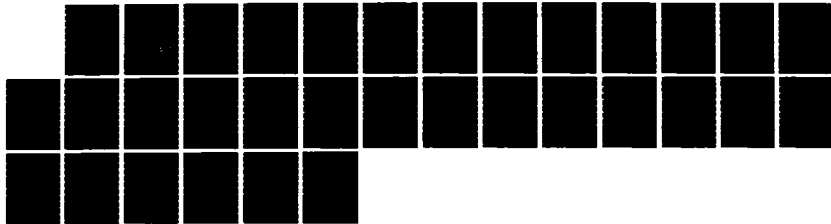

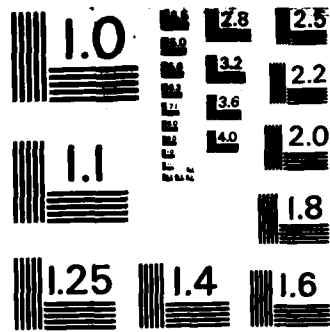

MICROCOPY RESOLUTION TEST CHART
NATIONAL BUREAU OF STANDARDS-1963-A

2

AD A139605

ISSUES SURROUNDING AN OIL IMPORT PREMIUM

Charles E. Phelps, Frank Camm, Fred Hoffman

September 1983

DTIC
ELECTE
APR 2 1984
S
D
B

DISTRIBUTION STATEMENT A
Approved for public release
Distribution Unlimited

DTIC FILE COPY

04 03 29 04

P-6903

PREFACE

This paper assembles some brief thoughts by the authors on issues surrounding implementation of an "import premium" for imported petroleum. An import premium represents any difference between the private marginal cost of petroleum imports and the social marginal cost. It can be implemented as a tariff on oil, a quota on imports, or as subsidies to alternative fuel sources produced domestically. The purpose of this paper is to identify some of the issues which need to be solved in order to know the appropriate level of the import premium (TIP).

The authors have lent only brief amounts of time to these issues. Many of the thoughts are found in other papers on the subject. In this paper, there are no attempts to estimate parameters which are needed to implement the analysis. It is a conceptual paper only.

This paper was presented at a conference on TIP at the Department of Energy, October 2-3, 1980. It should be of interest to analysts and policymakers in the area of petroleum import policy.

CONTENTS

PREFACE iii

Section

1. INTRODUCTION 1

2. METHODOLOGICAL ISSUES FOR AN OPTIMAL IMPORT PREMIUM . . . 4

 2.1 Monopsony Power 4

 2.2 Friends and Neighbors 10

 2.3 Bilateral Oligopoly 11

 2.4 The Refined and the Crude 14

 2.5 Macroeconomic Effect 16

 2.6 Long Run vs. Short Run 17

3. THE PREMIUM FOR REDUCING U.S. SUSCEPTIBILITY TO
A FOREIGN INTERRUPTION OF SUPPLY 18

 3.1 A TIP Methodology 18

 3.2 Problems with the TIP Methodology 18

 3.3 Final Remarks 25

4. CONCLUSIONS 27



Accession For	
NTIS GRA&I	<input checked="" type="checkbox"/>
DTIC TAB	<input type="checkbox"/>
Unannounced	<input type="checkbox"/>
Justification	
By _____	
Distribution/	
Availability Codes	
Dist	Avail and/or Special
A-1	

1. INTRODUCTION

This paper presents a brief collection of thoughts on elements contributing to an optimal oil import premium. The authors have spent only a very small time on the subject. The principal purpose of this informal paper is to collect these few thoughts together for those able to invest more resources in the problem. We raise many issues, and solve few, if any. We provide what appears (after brief analysis) to be a useful conceptual approach for dealing with some of these issues, but we have not implemented any analysis, nor have we made any estimates to optimize "The Import Premium" (TIP).

We have identified a series of elements contributing to TIP. No claim of completeness is being made, nor is there particularly any rank ordering of their ultimate importance (since we have not attempted to estimate key parameters associated with the models involved). The factors we have identified include:

which include:

1. The United States has monopsony power in world markets because our marginal purchase decisions can be large enough to affect aggregate world demand for oil. Thus a classic case arises for a tariff to reduce exportation of wealth on marginal consumption.
2. Reductions in U.S. demands for oil may improve our welfare on dimensions other than the oil market. We generate a benefit for other consuming nations by reducing our demands because the price reduction in world markets saves them real transfers in addition to those saved by the U.S. This may improve our ability, for example, to conduct international negotiations on a variety of issues, including other trade policy, joint defense treaties, and (obviously) the possibility of a coordinated effort of oil-consuming nations to reduce consumption jointly.
3. The oil market is not competitive on either side; it should probably be modeled as a bilateral oligopoly. One consequence

is that choice of policy instrument to effect TIP can be critical.

4. Trade in refined products requires that an import policy coordinate both the factor market (oil) and the final product market (products). General theoretical considerations suggest that the market power of the U.S. is approximately the same in product markets as it is in the market for crude oil. Issues associated with other elements of the import premium for crude oil also arise with products.
5. U.S. dependence on foreign oil sources increases the demand for U.S. military defense efforts. Secretary of Defense Harold Brown recently estimated the added costs from our Persian Gulf presence at \$5 billion per year. At least some of these costs could be reduced through reduction in import levels.

Alternative policies exist to offset the uncertainty generated by imports from unstable foreign sources, including public stockpiling (SPRO) and inducement of private stockpiling. Inherently, the conceptual measure needed to assess these issues is the private demand for inventories, but empirical analysis of such demands appears impossible to conduct for lack of data.

6. Imposition of an oil import tariff may have macroeconomic consequences for the U.S. Several mechanisms arise to suggest this, some with offsetting effects. First, the tariff would be designed to reduce currency outflow--payments to the U.S. Treasury would replace payments to OPEC. Thus the U.S. balance of payments would, on this mechanism alone, improve. However, an obvious effect with a contradictory force is the effect on factor prices of firms engaging in exports. The petrochemical industry is an important case. The increased factor price would make the U.S. firms less competitive and could in concept alter our position from that of net exporter to net importer, even in an industry where we are now major exporters. This would not only have

balance of payments effects, but obvious localized effects on employment, income and wealth distribution, and the environment.

7. The economic structure changes from the short run to the long run. Both demand and supply functions presumably become more elastic over time, and thus the optimal tariff also changes dynamically. There is no single optimal tariff, even if the world oil markets stand still.

The remainder of this paper extends some of these thoughts, not necessarily with uniform effort.

2. METHODOLOGICAL ISSUES FOR AN OPTIMAL IMPORT PREMIUM

2.1 MONOPSONY POWER

A case can be made for a nonzero optimal tariff anytime the excess supply curve for crude oil to the U.S.--the amount producers are willing to sell the U.S. at any price, *given* the amount other countries are willing to take at that price and the producers' cost and revenue considerations--is upward sloping over the range of U.S. demand for imported oil. The case is simple. The U.S. crude oil bill, $p(q)q$ (p is price; q is quantity) increases at a rate higher than the price of imported oil when the quantity of imports increases: $\partial[p(q)q]/\partial q = p + q(\partial p/\partial q) > p$. That is, the marginal cost of oil to the U.S. is higher than its price by a premium $q(\partial p/\partial q)$. U.S. well-being will increase if oil imports are priced at their marginal cost, that is, if a premium is charged for imported oil.

By phrasing the argument for a premium in terms of the concept of an optimal tariff, discussion of TIP can take advantage of basic results from the literature and many readers' familiarity with those results. Note, of course, that while traditional arguments about the exploitation of U.S. monopsony power are typically phrased in terms of a tariff, any policy instrument which drives a wedge between world and domestic U.S. prices equal to the premium is potentially acceptable. As we shall see below (Sec. II.3), the choice of a specific instrument can have an important effect on the size of the optimal premium.

2.1.1 A "Naive" Model

Models of world oil markets provide measures of $\partial p/\partial q$ and allow construction of an excess supply function (actually a reaction function, given the market control of the oil producers) under various assumptions about the way U.S. demand for imports is varied. Call the

function $p = g(q)$. Then the premium consistent with any level of imports, \bar{q} , is given by $\bar{q}g'(\bar{q})$. But there are two basic problems with the presentation: (a) It confuses the premium with a measure of value; and (b) it does not drive imports to the optimal level associated with this premium. Consider each in turn.

First, the premium is not a net value of import reduction. It is the net social gain to the U.S. associated with the *first* barrel of oil imports eliminated. But each additional barrel involves incremental losses in consumer utility (in excess of the incremental gains to domestic producers) that exceed the world price. This must be offset against the premium to measure the net incremental value of import reduction. To see this, look at Fig. 1. Fig. 1(a) represents the domestic U.S. market for crude oil, with traditional supply, $s(p)$, and demand, $d(p)$, functions. Excess demand for oil--U.S. demand for imports--can be defined by the difference between these, $d(p) - s(p)$; its inverse is represented in Fig. 1(b) by $f(q)$. $g(q)$ is the reaction curve described earlier; $h(q) \equiv g(q) + qg'(q)$. That is, $h(q) - g(q)$ is the appropriate premium on imported oil at any quantity of imports.

The import market now clears at (p^0, q^0) , leading to domestic production and consumption of s^0 and d^0 , respectively. Now suppose a premium of $h(q^1) - g(q^1)$ is chosen arbitrarily and used to set a tariff. Then the import market clears at (p_w^1, q^1) , reflecting a drop in world price. The domestic market clears at a price $p_{us}^1 < h(q^1)$ and levels of production and consumption of s^1 and d^1 . What is the incremental effect on U.S. well-being of small reductions in imports from q^0 and from q^1 ?

To find out, examine Fig. 2. The functions, prices, and quantities are the same as those in Fig. 1. Superimposed on these are several areas. Consider first an incremental reduction in imports from q^0 . This raises the domestic price of oil, thereby (a) reducing consumption by Δd^0 and (b) increasing production (by Δs^0) just enough to allow the proposed reduction in imports; this results, of course, from the definition of $f(q)$ ($\Delta d^0 = \Delta s^0 + \Delta q^0$). This reduction has several effects.

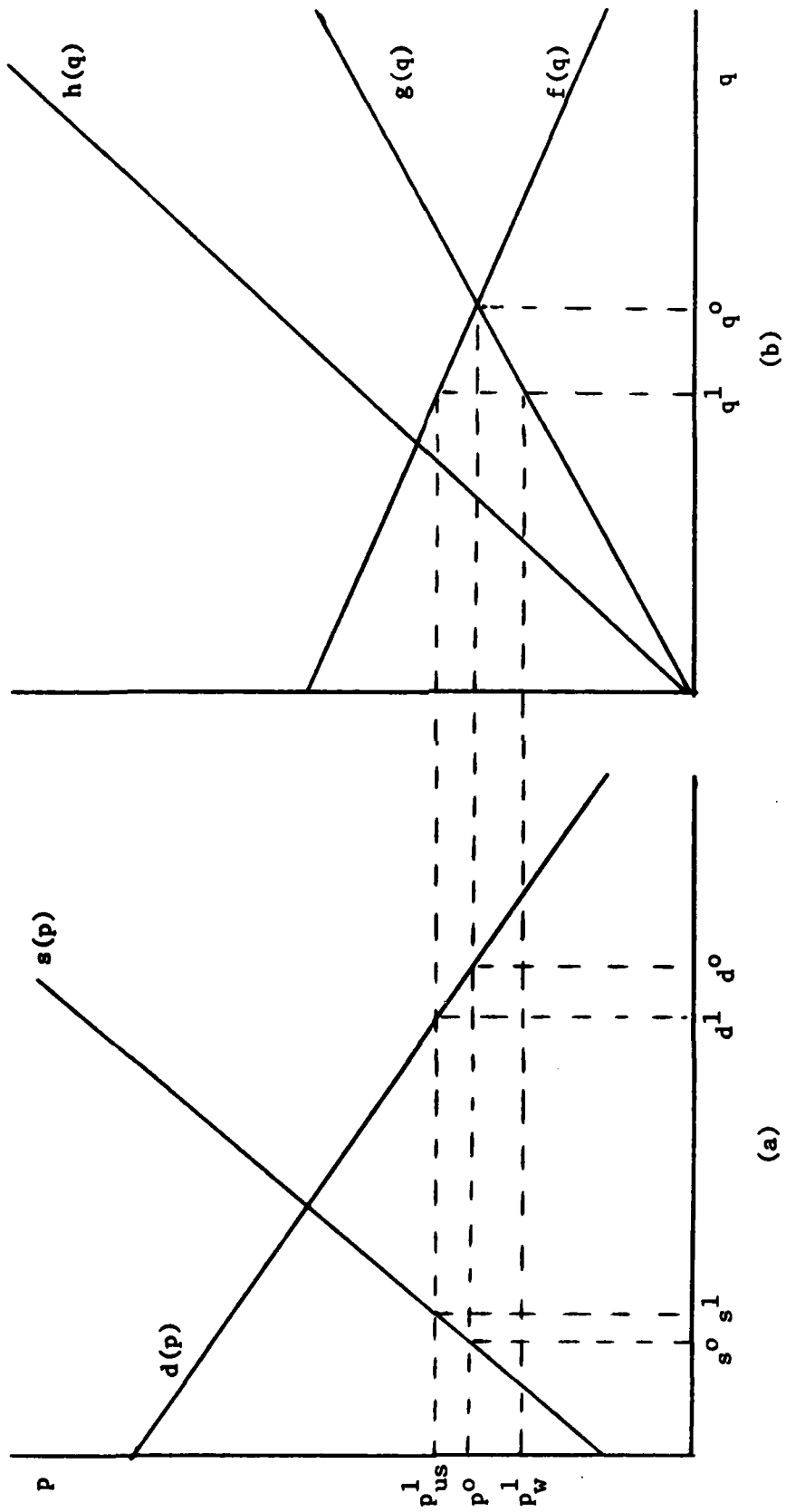

Fig. 1

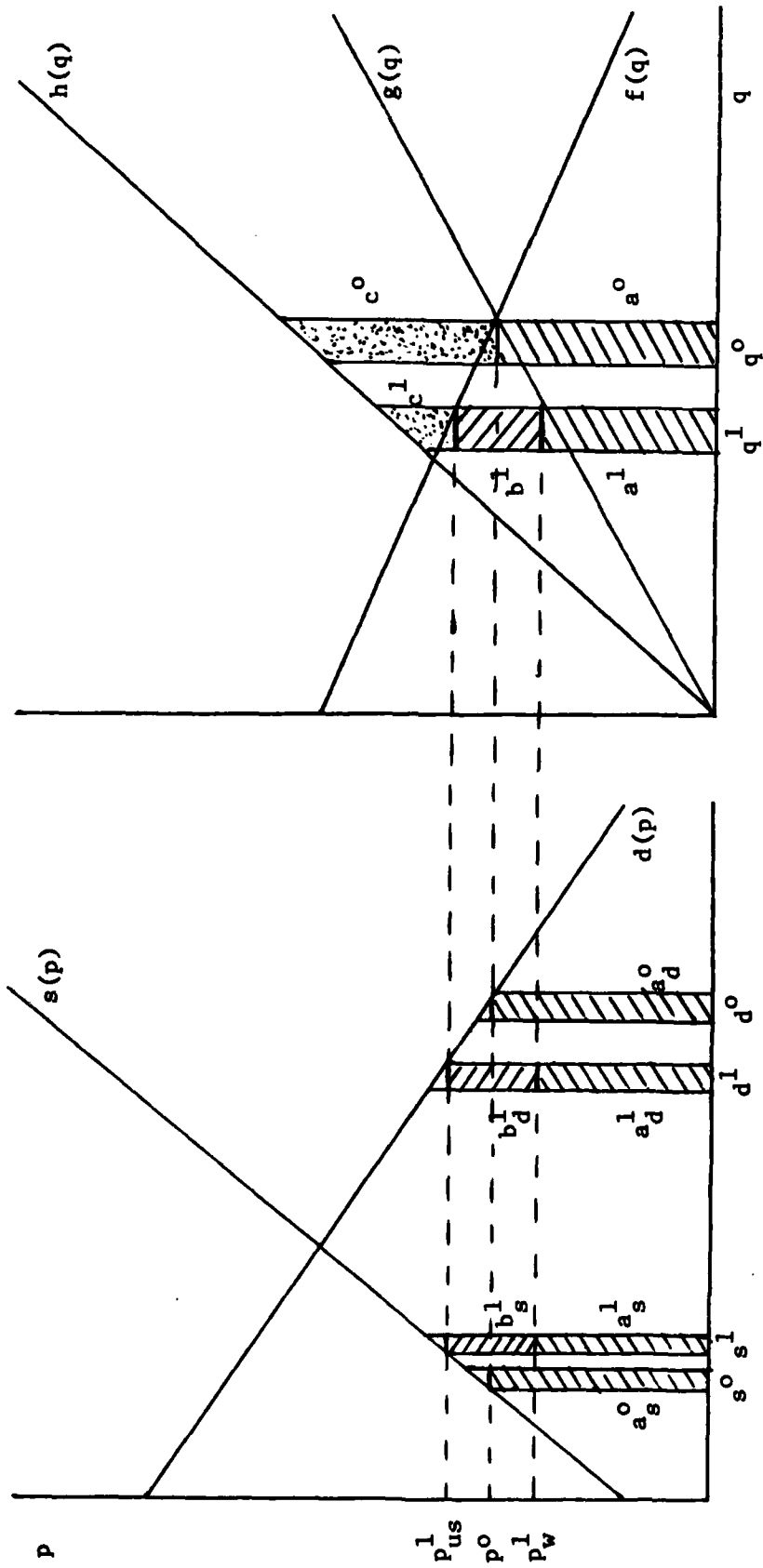

Fig. 2

First, it reduces the oil bill by the amount paid for the imports that have been eliminated, adding an amount equal to area a^0 ($-p^0 \Delta q^0$ or $p^0 dq$ as $\Delta q^0 \rightarrow 0$) to U.S. well-being. But this amount is offset by (a) the loss in utility to consumers, valued at a_d^0 ($-p^0 \Delta d^0$) and (b) the value of additional domestic resources devoted to oil production, a_s^0 (or $p^0 \Delta s^0$). $p^0 \Delta d^0 = p^0 \Delta s^0 + p^0 \Delta q^0$; and hence $a^0 = a_s^0 + a_d^0$, so that these areas offset one another. This leaves only the savings achieved on inframarginal imports, by definition $-[h(q^0) - g(q^0)] \Delta q^0$ or area c^0 . When $\Delta q^0 \rightarrow 0$, the marginal value of import reduction just equals the premium, itself the marginal savings on inframarginal purchases of oil.

Consider now a similar import reduction from q^1 . This reduction increases U.S. well-being by the amount paid for the imports eliminated, area a^1 or ($-p_w^1 \Delta q^0$). This gain is offset by losses from (a) lower consumption, $-p_{us}^1 \Delta d^1$ or $a_d^1 + b_d^1$ and (b) greater production, $p_{us}^1 \Delta s^1$ or $a_s^1 + b_s^1$. Analogously to our earlier discussion, $a^1 = a_s^1 + a_d^1$, leaving a net loss, $b_s^1 + b_d^1 = b^1$. This loss results quite simply because U.S. producers and consumers value the actual oil imports eliminated at the domestic price, p_{us}^1 , which exceeds the world price, p_w^1 , the amount saved directly on each barrel of imports eliminated. As $\Delta q^1 \rightarrow 0$, $b^1 \rightarrow (p_{us}^1 - p_w^1) dq$.

The effect of the premium, now $h(q^1) - g(q^1)$, remains to be examined. As before, the savings on the inframarginal oil bill effected by Δq^1 is $-[h(q^1) - g(q^1)] \Delta q^1$ or area $(c^1 + b^1)$. Net of direct domestic losses from the marginal imports forgone, then, the marginal value of the import reduction is $(c^1 + b^1) - b^1 = c^1$. The net marginal value implied, $h(q^1) - f(q^1)$, is less than the premium.

In fact, the net social value of an import reduction, say to \bar{q} , is the summation of marginal net values, $\int_{\bar{q}}^{q^0} [h(q) - f(q)] dq$. This is indicated in Fig. 3 by area C. C is smaller than a commonly used measure, indicated by area D, by the magnitude of area B_1 . To see this, note that $dg = g' dq$ and hence $\int_{\frac{p^0}{p_w}} \frac{q^0}{q} q dg = \int_{\frac{q^0}{q}} q g' dg$ or $D + B_2 = C + B_1 + B_2$; $D = C + B_1$. Naive measures neglect a portion of the perceived domestic loss associated with area b^1 in Fig. 2. If we treat the premium qg' as the value of a negative externality, so that $h(q)$ is the supply curve relevant to

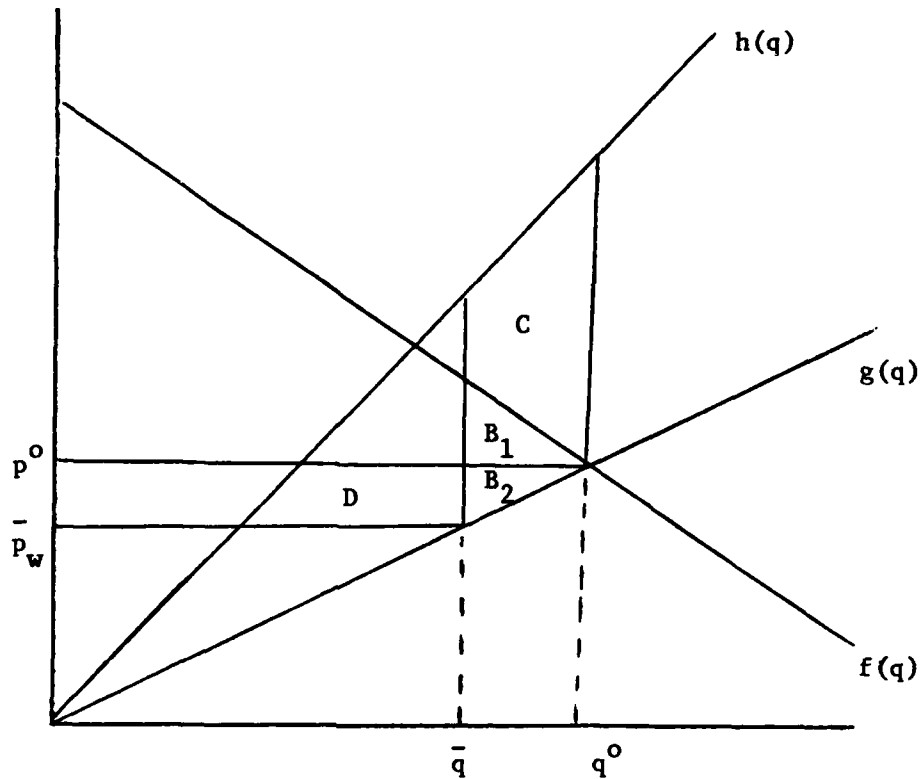

Fig. 3

welfare analysis, the proper measure of benefit from import reduction is represented by C , the familiar Harberger-Hotelling measure.

When we recognize this, the second difficulty in an initial presentation is easily remedied. It should be clear that the optimal premium or tariff is that which maximizes C . This premium is the one associated with a level of imports, q^* , for which $h(q^*) = f(q^*)$ or $q^* g'(q^*) = f(q^*) - g(q^*)$. Perceived incremental domestic losses on marginal imports [$f(q) - g(q)$ or b^1 in Fig. 2] just offset the incremental gains on inframarginal imports embodied in the premium. Depending on the form of f and g , this can be calculated numerically or analytically.

In sum, a "naive" model can be improved in two ways: (a) It overstates the benefits from import reduction by neglecting some of the losses associated with reduced domestic consumption of oil and increased domestic production. For small reductions in imports, this oversight is unlikely to be important. But it becomes more important for large reductions. Note that incremental gains from inframarginal

oil bill savings fall as reductions increase; incremental direct losses from marginal reductions in imports.

(b) Naive import premium models do not attempt to choose an optimal premium, presumably the value that makes the most sense to the paper as a whole. If TIP were chosen to maximize U.S. benefits, according to our initial naive model, it would be the optimal tariff that applied if U.S. demand for imports were infinitely elastic, thereby pushing B_1 in Fig. 3 to zero. Common wisdom suggests that the U.S. demand for imports is inelastic, suggesting in turn that this naive approach would reduce imports too much, but that the premium required to do this would be higher than the optimal premium associated with our measure, $q(\partial q/\partial p)|_{q=q^*}$.

2.2 FRIENDS AND NEIGHBORS

If the establishment of a premium leads to a reduction in U.S. imports, the world price of oil will fall, conveying a pecuniary benefit to Western Europe and Japan, among others. Optimizing TIP should take account of this benefit. Either out of the goodness of America's heart or, more likely, because healthy European and Japanese economies help sustain the U.S. economy and because such a pecuniary benefit can be exchanged for something else of value to the U.S., the U.S. cannot concern itself only with its own domestic well-being. The solution is simple.

Let $x_i = m_i(p_w)$ be the import demand function of our i^{th} friend. The net benefit he receives from imports is

$$\int_0^{\bar{x}_i} m_i^{-1} dx_i - m_i p_w .$$

The change in benefits accompanying a change in world price is $[m_i^{-1} m_i' - (m_i + p_w m_i')] dp_w = \bar{x}_i dp_w$ evaluated at \bar{x}_i . Hence, the premium of marginal cost over world price of an additional barrel of oil to the U.S. is now $(q + \sum \alpha_i x_i)(\partial p/\partial q)$, where α_i ($0 \leq \alpha_i \leq 1$) is a measure of the value the U.S. places on pecuniary benefits realized by its i^{th} friend.

For all $\alpha_i = 0$, our original measure of the premium holds. If we place any value on benefits to friends, the relevant premium rises, calling for a greater cut in U.S. imports. For all $\alpha_i = 1$, the U.S.

simply considers the savings on total inframarginal consumption of all its friends taken together in setting the premium. So long as the U.S. asks for no import adjustments on the part of its friends in response to this consideration, $\partial p/\partial q = g'$ is essentially the same as in our earlier analysis. But if the U.S. and its friends plan together and calculate a jointly optimal premium, $\partial p/\partial q$ is likely to change. Unfortunately, its direction of change is hard to predict. If the U.S. and friends act together as a perfect unitary monopsonist, the function of interest becomes $\partial p/\partial(q + \Sigma x_1)$. Because the excess supply function faced by this monopsonist is less elastic than that faced by the U.S. alone (because the function no longer reflects the demand of the friends of the U.S.), one might expect $\partial p/\partial(q + \Sigma x_1) > \partial p/\partial q$. But the bilateral market power in the world oil market makes this less than certain (see Section 2.3). If the U.S. and friends have a looser arrangement, $\partial p/\partial q$ reflects the conjectural variations of the parties to the arrangement, making things even more complicated. International cooperation among the consuming nations, then, may increase or decrease the optimal premium and the reduction in U.S. imports associated with it.

In sum, failure to consider the effect of U.S. actions on its friends leads to an underestimate of the proper premium and potentially a higher level of U.S. imports than desirable. These problems are compounded by a failure to consider cooperation among consuming nations. While these additional complications are not easily incorporated into TIP's considerations, they can clearly be treated parametrically.

2.3 BILATERAL OLIGOPOLY

Good models of oligopolistic and oligopsonistic decisionmaking are not available. Good models of bilateral market power, even in the simple case where monopolies prevail on each side of a market, are not available either. The world oil market displays oligopolistic behavior on the supply side and consideration of optimal import premiums for the consuming nations raises the potential of oligopsonistic behavior as well. Because we have no one satisfactory way to deal with

these compounded difficulties, we are left in the unsatisfying position of having to consider alternative scenarios and to test for robustness.

Extant models reflect this difficulty on the supply side. The lack of robustness in their results is not particularly encouraging. It appears that the choice of world scenario drives any estimate of an applicable premium.

Unfortunately, this will only get worse when cooperation on the consumption side of the world market is considered. But we may be able to make some qualitative statements. For example, all oligopoly models traditionally considered show that decisionmakers who act separately never achieve the full benefits available from a monopoly enforced by one decisionmaker. We should expect a similar result for oligopsony. In particular, it is probably possible--for a given supply reaction function (g)--to calculate a monopsonistically optimal premium for the industrial western democracies. We can be quite confident that the relevant premium falls short of this, but can be increased by greater cooperation. Unfortunately, any more specific statements require a model far more complex than that suggested above. And, of course, the supply reaction function is not independent of decisions made by the consuming nations.

2.3.1 The Importance of Policy Tool Choices

This interdependency of supply and demand, of course, leads to indeterminacy without restrictive and generally unrealistic assumptions. But even when such assumptions are applied, it is clear that the calculated solution will depend on the way in which U.S. imports are reduced, not just the size of the reduction. A simple example may help make this clear.

Consider a monopolist with a marginal cost function $q = a_0 + a_1p$ facing a demand function $q = b_0 + b_1p$. His marginal revenue function is $q = (b_0 + b_1p)/2$. Reduced form equations for price and quantity are

$$p = \frac{a_o b_1 - b_o b_1 + a_1 b_o}{b_1 (b_1 - 2a_1)}$$

$$q = \frac{a_o b_1 - a_1 b_o}{b_1 - 2a_1} .$$

We can trace out a supply reaction curve by varying demand. If all variations result from changes in b_o , $\partial p / \partial q$ for this reaction curve is

$$\frac{\partial p}{\partial q} = \frac{a_1 - b_1}{-a_1 b_1} .$$

If variations result from changes in b_1 , $\partial p / \partial q$ becomes

$$\frac{\partial p}{\partial q} = \frac{b_1^2 (b_o - a_o) + 2a_1 b_o (a_1 - b_1)}{a_1 b_1^2 (b_o - 2a_o)} .$$

Conservation programs, subsidies to new domestic substitutes for oil, import quotas, and other policies that might be used to reduce imports affect the import demand equation in different ways. Hence, they also will affect the supply reaction curve used to calculate the premium and the size of the premium itself. Thus, although discussion of an optimal import premium is useful, we cannot afford to ignore the specifics of policy tools chosen, for each can have ultimately different consequences.

A careful analysis of TIP would include an oligopsonistic relationship likely to exist between the United States and the other consuming states. It would capture the ways the producing nations will react to different U.S. initiatives to reduce imports. Unfortunately, there is no easy way to include these additional problems. But the appropriate import premium is likely to be very sensitive to behavioral assumptions about the world's bilateral oligopoly. Failure to consider these additional problems may well bias any estimated optimal import premium in an unpredictable way.

2.4 THE REFINED AND THE CRUDE

Some models deal only with the international market for crude oil, but other markets for refined products will complicate things. For example, if the import premium is reflected in a tariff on imported crude oil, this will raise the cost of refining in the U.S. and increase the demand for imported refined products and other goods, such as petrochemicals, in which crude oil is an important element in production cost. An import quota will do the same thing. The result could be an increased use of imported refined products, themselves refined from foreign oil, and no net decrease in U.S. dependence on foreign sources or in the bill paid for foreign oil. If anything, dependence increases as another stage of production moves beyond U.S. borders. This is precisely what happened when the import quota of the 1960s was first imposed. The dramatic increase in refined imports associated with the quota had to be cut off by quotas on refined products as well.

With respect to calculations of an optimal tariff, a decision to place a tariff only on crude raises the demand and supply elasticities relevant to the decision significantly. U.S. consumers simply switch to refined imports and imports of other petroleum products, reacting strongly to any increase in the domestic price for crude. And any reduction in world price that results from U.S. crude import cuts will be made up by increased derived demand for crude elsewhere as U.S. demand for refined and other petroleum products rises. (Because crude imports were preferred to refined imports before, a switch to refined products will probably involve some cost penalty. Hence, a cut in U.S. crude imports will cut world demand for crude slightly. But the cut is not likely to be significant.) The effect is similar to taxing one of two good substitutes for one another and then watching demand and supply response for the taxed good. The high elasticities that result, then, can justify only the smallest import premium and trivial crude import cuts. World models ignoring trade in product will bias demand and supply response downward because they are not likely to include structural equations specified in a way that allows them to capture these effects.

To gain inframarginal savings on imported oil (and reduced dependence), then, all forms of petroleum imported must be considered. In competitive domestic markets, the linkages among various products and crude oil can be worked out to determine the appropriate premium for each product. The premium is likely to be related closely to the "crude oil content" of each product. The increasingly complex net of U.S. domestic controls on oil and oil products, however, will make that task significantly more difficult. Because the full effects of most of these controls are not yet understood, much less modeled, we face a nontrivial task of just defining a set of import premiums. Determining the savings from any set or attempting to choose an optimal set is harder still.

Note that the complexity associated with these myriad tariffs on quotas may be avoided by subsidizing domestic substitutes for petroleum and thereby reducing U.S. dependence on imported petroleum. For example, one possible substitute is synfuel. While such a subsidy will reduce imports, it does not inform consumers of the social value of oil implied by a positive premium. Hence, excess consumption of the services provided by oil and its substitutes actually increases. And unsubsidized substitutes are not exploited as fully as would be socially desired and in fact are likely to be used less than in the absence of the subsidy (because of substitution toward the subsidized substitute). *It is easy to show that these adverse effects of a subsidy dictate an optimal subsidy smaller than the import premium and a less satisfactory outcome than that associated with an optimal set of quotas or tariffs.* But the administrative costs associated with a complex tariff/quota scheme may absorb any social gain associated with moving from a subsidy to a tariff scheme. Of course, one should keep in mind that a set of subsidies on more than a few oil substitutes has its own nontrivial administrative costs.

In sum, the import market for crude oil cannot be considered in isolation. Any attempt to capture inframarginal savings via import reduction will fail unless all potential import markets for petroleum products are considered. Joint consideration of these markets, given our current ignorance about the structure and effects of domestic regulations, can be expected to be extraordinarily difficult.

2.5 MACROECONOMIC EFFECT

Our consideration of macroeconomic issues is minimal. However, several issues appear pertinent when discussing an optimal import premium. The first issue concerns the consequences for balance of payments, treasury receipts, and consequent possible effects on macroeconomic variables such as the price level and real GNP. An import premium obviously serves to reduce the export of U.S. currency overseas, through reduction in both quantity and price of imported oil. The macroeconomic consequences of this depend considerably on parallel movements in other U.S. policies, e.g., tax structure, money supply, and importantly, the consequences of any attempts to hold harmless the economic agents materially affected by the new policy. (More about this momentarily.)

Implementation of any import reductions in crude oil will increase factor costs for anybody employing oil or its derivatives in manufacturing. (The refined product industry is so important that it was dealt with above.) Other pertinent industries also appear, most notably the petrochemical industry. The factor price increase associated with TIP will shift marginal cost curves in these industries upward, reducing exports (or increasing imports) and (if world trade is not infinitely elastic) also modifying prices received (paid). The U.S. chemical industry exported \$17.3 billion in value in 1979; much of this was petrochemicals. This represented 12 percent of chemical industry sales, and more importantly for macroeconomic issues, represented nearly 10 percent of the value of U.S. exports. If the U.S. implements TIP unilaterally, it is almost certain that our trade accounts would suffer in such industries, offsetting gains achieved elsewhere through reduction of petroleum-related imports.

An important ancillary issue is how these losses are distributed. U.S. economic policy has a longstanding tradition of attempting to neutralize the shocks of economic change, especially if the affected groups are concentrated in a fashion allowing effective political representation. Such efforts could include marginal or inframarginal compensation to affected firms, modification of tax law to offset economic blows, or other economic arrangements. The magnitude of

revenue and profit redistribution associated with implementation of TIP practically guarantees that some of these adjustments will be undertaken to maintain political support for TIP. Their economic consequences must logically be factored into analysis of the optimal TIP. Implementation costs (political compromises) could consume much or all of the welfare gains associated with TIP, if not carefully considered.

2.6 LONG RUN VS. SHORT RUN

The continued consumer response to the 1979 OPEC price increases reminds us that demand and supply elasticities differ in the long run from the short run. Estimates of long-run petroleum demand elasticities suggest that they exceed short-run elasticities by perhaps an order of magnitude, or at least half that. Optimization of TIP requires a dynamic formulation, with the magnitude of TIP, and perhaps even the policy instruments chosen to implement TIP, reconsidered periodically as consumers and producers have the opportunity to adjust to increased petroleum prices associated with TIP. We have not developed this notion further and cannot even say at present whether this implies higher or lower values for TIP in the long run.

3. THE PREMIUM FOR REDUCING U.S. SUSCEPTIBILITY TO A FOREIGN INTERRUPTION OF SUPPLY

3.1 A TIP METHODOLOGY

Increasing current imports increases the likely dependence of the U.S. economy on foreign oil during a future interruption and thereby increases the likely cost of such an interruption. One way to reduce the cost of any future interruption is to maintain a strategic reserve from which oil can be drawn for domestic use during an interruption. Such a reserve should be increased in size just to the point where the marginal cost of adding an additional barrel equals the benefit that barrel can be expected to provide in a future interruption (adjusted, of course, for probability of an interruption, discount rate, and so on).

The optimal size of a reserve increases as the level of imports increases. That is, an increase in imports increases the marginal benefit from the last barrel of the reserve above its marginal cost, pushing the optimal level of the reserve up. Now *suppose* that the optimal reserve (R) for any level of imports (I) is proportional to the level of imports: $R = kI$. Then optimal behavior places the real cost of imported oil above its cost in the absence of future embargoes by just the cost of the optimal incremental reserves associated with each increment of imports: $C_R \Delta R = C_R k \Delta I$ for C_R the average cost of reserves over ΔR . Hence, $C_R k \Delta I / \Delta I$ or $C_R R / I$ is the appropriate premium for reducing U.S. susceptibility to foreign supply interruptions.

3.2 PROBLEMS WITH THE TIP METHODOLOGY

Given the assumptions posited, the analysis presented is essentially correct. But the assumptions are quite unrealistic. And it is easy to show that the answers given are so sensitive to the assumptions that they become uninteresting when we change the assumptions. To see

this, let us first construct a simple model and then use it to illustrate two basic problems with this methodology.

3.2.1 A Simple Model

Let national well-being or utility (U) be an increasing function of oil consumption (O), security (S), and all other goods (X). Now consider two policy instruments which can affect national well-being by affecting these arguments. A strategic reserve (R) affects security, $\partial S/\partial R > 0$. Note that any of a number of other policies which reduce the effects of an embargo or its probability could be treated in a similar way. A complete analysis would treat R as a basket of such policies. Imports (I) allow more oil consumption, $\partial O/\partial I > 0$ ¹ and reduce security, $\partial S/\partial I < 0$. Hence, effects of imports and reserves on utility can be expressed as

$$\frac{\partial U}{\partial I} = \frac{\partial U}{\partial O} \frac{\partial O}{\partial I} + \frac{\partial U}{\partial S} \frac{\partial S}{\partial I} > 0$$

$$\frac{\partial U}{\partial R} = \frac{\partial U}{\partial S} \frac{\partial S}{\partial R} > 0 .$$

Now choose levels of R and I to maximize national well-being. To do this, consider a Lagrangian

$$\begin{aligned} \max_{I, R, X} U(I, R, X) - \lambda(p_I I + p_R R + X - Y) \end{aligned}$$

¹If D is domestically produced oil, $O = I + D$ and $\partial O/\partial I = 1 + \partial D/\partial I$. $\partial D/\partial I$ can be positive or negative, depending on the reason for a change in imports, but never less than -1. Hence $\partial O/\partial I > 0$, $\frac{\partial O}{\partial I} > 1$.

in which X is taken as a numeraire. First-order conditions require

$$\frac{\partial U}{\partial I} = \frac{\partial U}{\partial O} \frac{\partial O}{\partial I} + \frac{\partial U}{\partial S} \frac{\partial S}{\partial I} = \lambda p_I$$

$$\frac{\partial U}{\partial R} = \frac{\partial U}{\partial S} \frac{\partial S}{\partial R} = \lambda p_R$$

$$\frac{\partial U}{\partial X} = \lambda$$

$$p_I I + p_R R + X = Y .$$

Two important insights come out of these results. First, for optimization, the price of imports must equal the sum of two terms:

$$p_I = \frac{(\partial U/\partial O)(\partial O/\partial I)}{\partial U/\partial X} + \frac{(\partial U/\partial S)(\partial S/\partial I)}{\partial U/\partial X} .$$

The first is that traditionally associated with the demand for oil. It is the marginal value, in dollar terms, of a totally secure barrel of imported or domestically produced oil. The second term shows how much the possibility of a future interruption should reduce our valuation of foreign oil. At an optimum, then,

$$\frac{(\partial U/\partial O)(\partial O/\partial I)}{\partial U/\partial X} = p_I + \pi$$

for $\pi = \frac{(\partial U/\partial S)(\partial S/\partial I)}{\partial U/\partial X}$. Our marginal valuation of oil is the sum of a world price and a security related premium.¹

¹ Note that if we assume that the U.S. faces an upward sloping curve for oil, p_I is the marginal cost of that oil, incorporating within it the premium discussed earlier. The two premia are additive, but they are not independent of one another.

Second, the mutually optimal choice of I and R occurs when

$$\frac{p_I}{p_R} = \frac{\frac{\partial U}{\partial I} \frac{\partial \theta}{\partial I} + \frac{\partial U}{\partial S} \frac{\partial S}{\partial I}}{\frac{\partial U}{\partial S} \frac{\partial S}{\partial R}} .$$

Figure 4 shows this graphically. u_0 , u_1 and u_2 are indifference curves for $U = U_0, U_1, U_2$; $U_2 > U_1 > U_0$.

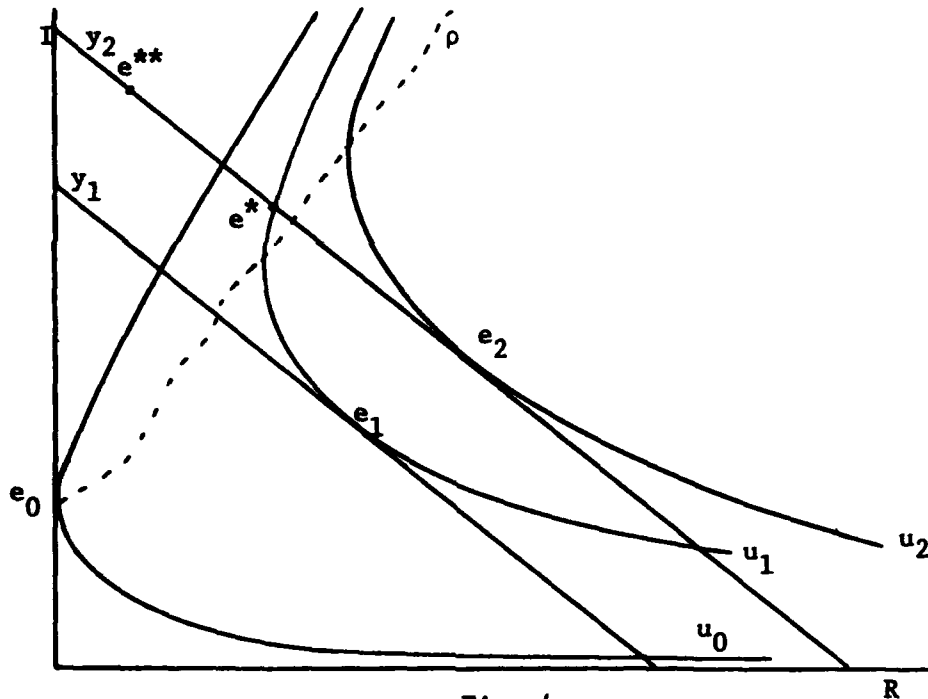

Fig. 4

They take an unconventional shape because, for any given level of R, $\partial U/\partial I$ becomes negative as I increases, causing the slope of these indifference curves, $-(\partial U/\partial R)/(\partial U/\partial I)$ to become positive. y_1 and y_2 are budget lines reflecting $Y_1 - X_1$ and $Y_2 - X_2$. Their slope is $-p_R/p_I$. The first-order conditions state that an optimum for any budget line occurs at the point where it is tangent to an indifference curve, as at e_1 or e_2 .

We can note several things about this optimum. First, because $-p_R/p_1$ cannot be positive, optima always lie below the "ridge line," ρ , along which $\frac{\partial U}{\partial O} \frac{\partial O}{\partial I} - \frac{\partial U}{\partial S} \frac{\partial S}{\partial I} = 0$. Hence, imports will optimally always on net be a good, in spite of their negative effect on security. And policy choices which put us above this locus, for example at e^* , can always be improved. Second, below ρ , U is convex to the origin and hence *could* be homothetic in this region. This would allow the proportionality between R and I along an optimal expansion path that TIP assumes. But it in no way guarantees it. Third, if the price of reserves were infinite, we would not use any of them and we would choose a level of imports where $-(\partial U/\partial R)/(\partial U/\partial I) \rightarrow \infty$. In Fig. 4, this occurs at the intercept of ρ , at e_0 . The level of well-being at this point, U_0 , is the lowest we need accept, even though current policy choices may have put us below this level, for example at e^{**} .

The inherent nature of a reserve of oil in enhancing our national security is probabilistic. Hence, the gains from a reserve must be evaluated in terms of *expected utility*, rather than in a deterministic framework, as specified above. To undertake such an analysis requires knowledge of the probability distribution of import interruptions of various magnitudes and durations, a formidable task. But such knowledge is requisite for determination of any sort of optimum stockpiling or inventorying policy. An analogous problem has been investigated from the standpoint of buying market insurance vs. undertaking activities which either (a) reduce the chances of an interruption of supply, or (b) mitigate the consequences of an interruption, if it occurs. A stockpile of oil could have effects in either of these dimensions.¹

3.2.2 Evaluating TIP as Storage-Cost Offsets

Even if we do know and achieve the optimal level of reserves, any measure of the premium depending on offsets of storage costs is suspect. But we are unlikely even to know where the optimum is. Consider each problem in turn.

¹The most pertinent literature is Isaac Ehrlich and Gary Becker's "Market Insurance, Self-Insurance, and Self-Protection," *Journal of Political Economy*, July/August 1972, pp. 623-48.

At the optimum, we know that

$$\pi = - \frac{(\partial U/\partial S)(\partial S/\partial I)}{\partial U/\partial X} .$$

And the first-order conditions require that

$$P_R = - \frac{(\partial U/\partial S)(\partial S/\partial R)}{\partial U/\partial X} .$$

Hence,

$$\pi = - \frac{\partial S/\partial I}{\partial S/\partial R} P_R .$$

For a storage-cost based measure of the premium to hold, it must be true that $\frac{R}{I} = - \frac{\partial S/\partial I}{\partial S/\partial R}$. That is, (a) security is homothetic in I and R; (b) import reductions and reserves have a unitary elasticity of substitution in the production of security:

$$d \ln \left(\frac{I}{R} \right) = -d \ln \left(\frac{-\partial S/\partial I}{\partial S/\partial R} \right);$$

and (c) I/R at the optimum is known. These conditions are quite restrictive; if the u_i in Fig. 4 are homothetic, as required, they imply that the direct utility function is homothetic in oil consumption and reserves, an unusual requirement.

Furthermore, such a methodology must use the appropriate measure of cost. One could attempt to avoid this problem by setting marginal and average cost equal and constant. This assumption does not appear to be consistent with the evidence that the U.S. faces a rising supply curve. The price of oil in the reserve should include any monopolistically motivated premium.

The basic point of all this is that, at the optimum, the premium is related to the price of reserves by a rate of transformation, $-(\partial S/\partial I)/(\partial S/\partial R)$, between imports and reserves, not by the levels of imports and reserves. To say that we can measure this rate of transformation with absolute levels of imports and reserves is less realistic than it might first appear to be.

The appeal of such a measure for TIP apparently stems from our ability to know I/R. But knowing that--or, more appropriately, $(\partial S/\partial I)/(\partial S/\partial R)$ --requires the same kind of knowledge that knowing $-(\partial U/\partial S)/(\partial U/\partial X)$ or $\partial S/\partial I$ does. If we know enough to construct π from p_R , we probably know enough to estimate π directly. But what little convenience results from exploiting the relationship between p_R and π at an optimum is likely to break down in most realistic cases. In most cases, even if we know the optimal R and I, we will not find ourselves at an optimum. And π is quite sensitive to departures from optimum.

Consider variations in π when R and I change:

$$\text{sgn } \frac{\partial \pi}{\partial R} = -\text{sgn} \left[\frac{\partial S}{\partial I} \frac{\partial S}{\partial R} \left(\frac{\partial U}{\partial S} \frac{\partial^2 U}{\partial X \partial S} + \frac{\partial U}{\partial X} \frac{\partial^2 U}{\partial S^2} \right) + \frac{\partial^2 S}{\partial I \partial R} \frac{\partial U}{\partial S} \frac{\partial U}{\partial X} \right] < 0$$

$$\text{sgn } \frac{\partial \pi}{\partial I} = \text{sgn} \left[\left(\frac{\partial S}{\partial I} \right)^2 \left(\frac{\partial U}{\partial S} \frac{\partial^2 U}{\partial S \partial X} - \frac{\partial U}{\partial X} \frac{\partial^2 U}{\partial S^2} \right) + \frac{\partial S}{\partial I} \left(\frac{\partial U}{\partial S} \frac{\partial^2 U}{\partial X \partial I} - \frac{\partial U}{\partial X} \frac{\partial^2 U}{\partial S \partial I} \right) - \frac{\partial^2 S}{\partial I^2} \frac{\partial U}{\partial X} \frac{\partial U}{\partial S} \right] > 0 .$$

The cost of future interruptions falls as reserves increase, calling for a smaller premium as reserves rise. The effect of imports on the premium is harder to characterize. The numerator of the premium, $-(\partial U/\partial S)(\partial S/\partial I)$, clearly rises as imports rise but the denominator, $\partial U/\partial X$, can go either way. Of primary importance, however, is that both of these partials are nonzero. Clearly, the premium called for at any given level of imports rises as reserves fall away from their optimal level. To know how high the premium rises under these circumstances, we must have the same sort of knowledge required to choose optimal I and R in the first place. We can only say that a premium estimated for the optimal oil reserve is likely to understate the premium likely to be appropriate *at our current or likely level of imports and reserves.*

In the end, then, any inference about the premium derived from the cost of reserves is correct *if* we are at the optimum, *if* we make very restrictive assumptions about the production of security and

national well-being in general, and *if* we accept that the marginal cost of an oil reserve is constant. If we are not at an optimum-- and we are unlikely to find ourselves at one in the foreseeable future--then any cost-of-reserves-based methodology provides only a lower bound on the appropriate premium.

3.3 FINAL REMARKS

At the optimum, the appropriate premium is

$$- \frac{\partial S / \partial I}{\partial S / \partial R} P_R \cdot$$

Away from the optimum, it is

$$- \left(\frac{\partial U / \partial S}{\partial U / \partial X} \right) \left(\frac{\partial S}{\partial I} \right).$$

It may be somewhat easier to make statements about the premium at the optimum because no knowledge of the utility function is required there. But given the vague quality of "security" as an intermediate good and the difficulty we are likely to have in measuring it in a way that is separate from GNP or some other measure of well-being, such a distinction is likely to be academic. Any way we look at it, we have likely not eliminated the need for considerably more understanding of the world than we have now.

Whichever measure is used, the following types of questions will have to be addressed. (a) What is the probability distribution of interruptions by length, depth, and number over varying time horizons? (b) How do various U.S. actions now, immediately preceding an interruption, and during an interruption affect these probabilities? (c) What will the U.S. response to various scenarios be? In particular, how will the oil reserve be disbursed; what prices will be allowed to adjust; how will property rights to private inventories be assigned; what mandated changes will be made in industrial and utility fuel use, speed limits, and residential and commercial use of lighting and space conditioning; and how quickly will these actions take place

following the start of an interruption? (d) Given the answers to questions in (c), how will interruptions of various kinds affect GNP, various activities important to defense and employment, and income received by political/social groups of special interest to the government? We suspect that good answers are available today to none of these questions. But the need remains as great as ever.

4. CONCLUSIONS

Making a case in favor of premiums is relatively easy. Given an upward sloping supply curve of oil to the United States, the U.S. has some market power which it can exploit to lower the price it pays for imported oil by reducing imports. And given what appears to be an increasing likelihood of future interruptions in U.S. oil imports, coupled with severe domestic disincentives to private provision for these interruptions, U.S. well-being is likely to be improved by reducing imports below the level determined by the market. Each reduction in imports implies a divergence between the world price of oil and the U.S. domestic valuation of it. And each divergence can be characterized as a premium.

Unfortunately, while we can be fairly sure that premiums associated with U.S. monopsony and reduced dependence should be positive, putting specific numbers on each premium is a nontrivial problem. *Given* a supply function, we can speak of an optimal tariff for a monopsonistic U.S. or the U.S. and friends. But we cannot take the supply function as given. Oligopoly prevails on both sides of the world oil market, leading not only to no single defensible world equilibrium, but also to no easily defined OPEC response to specific U.S. actions to reduce imports. These problems all arise in the crude oil market; a monopsonistic premium becomes even more complicated when we draw refined products and other petroleum products into the picture, as we must to restrict imports effectively.

Similarly, *given* an optimal level of reserves and a number of restrictive assumptions, we can make certain statements about the optimal level of imports from a security point of view. But assuming away the estimation of an optimal level of reserves really assumes away the heart of the security problem. And it does not tell us anything about a premium relevant to positions away from the optimum positions likely to be the most policy relevant.

Unfortunately, the nature of the problems is that they are hard to avoid and, in the end, more limited analysis does not allow us to do so. To the extent that we believe that the determination of a more desirable level of imports is important--and we believe it is--we must be willing to face the problems set forth here.

END

FILMED

5-84

DTIC