

AD-A139 822

HYDRAULIC PRESSES(U) FOREIGN TECHNOLOGY DIV
WRIGHT-PATTERSON AFB OH B V ROZANOV 09 MAR 84
FTD-ID(RS)T-1207-83

1/10

UNCLASSIFIED

F/G 13/9

NL

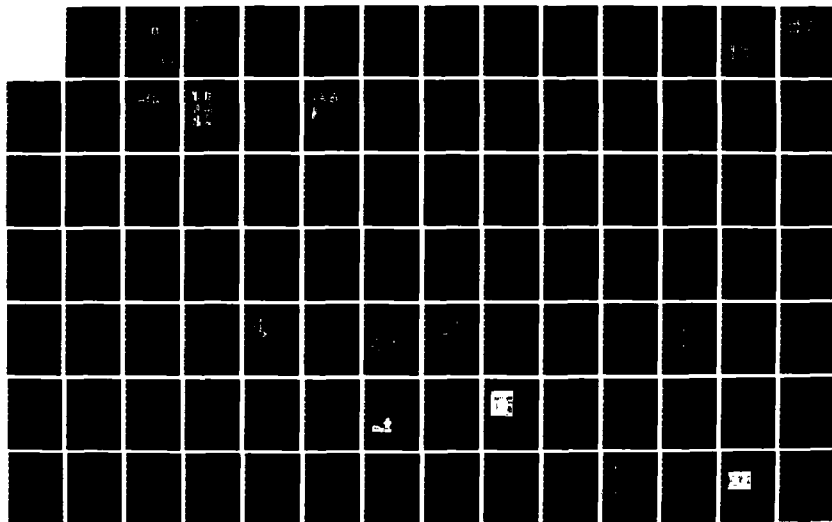

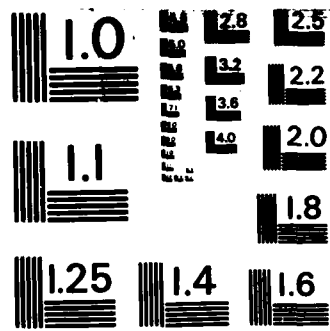

MICROCOPY RESOLUTION TEST CHART
NATIONAL BUREAU OF STANDARDS-1963-A

FOREIGN TECHNOLOGY DIVISION



HYDRAULIC PRESSES

by

B. V. Rozanov

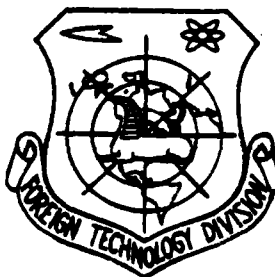

DTIC
ELECTE
APR 5 1984
S D D

Approved for public release;
distribution unlimited.

AD A139822

DTIC FILE COPY



UNEDITED MACHINE TRANSLATION

FTD-ID(RS)T-1207-83

9 March 1984

MICROFICHE NR: FTD-84-C-000257

HYDRAULIC PRESSES

By: B. V. Rozanov

English pages: 878

Source: Gidravlicheskiye Pressy, Publishing House
Mashinostroitel'noy, Moscow, 1959, pp. 1-428,
3 unnr pgs

Country of origin: USSR

This document is a machine translation.

Requester: FTD/TQIA

Approved for public release; distribution unlimited.

Accession For	
NTIS GRA&I	<input checked="" type="checkbox"/>
DTIC TAB	<input type="checkbox"/>
Unannounced	<input type="checkbox"/>
Justification	
By _____	
Distribution/ _____	
Availability Codes	
Dist	Avail and/or Special
P/1	

THIS TRANSLATION IS A RENDITION OF THE ORIGINAL FOREIGN TEXT WITHOUT ANY ANALYTICAL OR EDITORIAL COMMENT. STATEMENTS OR THEORIES ADVOCATED OR IMPLIED ARE THOSE OF THE SOURCE AND DO NOT NECESSARILY REFLECT THE POSITION OR OPINION OF THE FOREIGN TECHNOLOGY DIVISION.

PREPARED BY:

TRANSLATION DIVISION
FOREIGN TECHNOLOGY DIVISION
WP-AFB, OHIO.

DTIC
COPY
INSPECTED
3

Table of Contents

U.S. Board on Geographic Names Transliteration Systems	ii
Chapter I. Basic Concepts and General Arrangement	2
Chapter II. Constructions/Designs Characteristics of the Presses of Different Designation/Purpose	41
Chapter III. Constructions and Calculation of Basic Assembles and Parts of Press	257
Chapter IV. Elements of the Calculation of Hydraulic Systems of Presses	397
Chapter V. Pumps of Hydraulic Press Installations/Settings Up	544
Chapter VI. Pump-and-Battery Stations	616
Chapter VII. Hydraulic Systems, Distributors and Equipment	720
References	877

U. S. BOARD ON GEOGRAPHIC NAMES TRANSLITERATION SYSTEM

Block	Italic	Transliteration	Block	Italic	Transliteration
А а	<i>А а</i>	A, a	Р р	<i>Р р</i>	R, r
Б б	<i>Б б</i>	B, b	С с	<i>С с</i>	S, s
В в	<i>В в</i>	V, v	Т т	<i>Т т</i>	T, t
Г г	<i>Г г</i>	G, g	У у	<i>У у</i>	U, u
Д д	<i>Д д</i>	D, d	Ф ф	<i>Ф ф</i>	F, f
Е е	<i>Е е</i>	Ye, ye; E, e*	Х х	<i>Х х</i>	Kh, kh
Ж ж	<i>Ж ж</i>	Zh, zh	Ц ц	<i>Ц ц</i>	Ts, ts
З з	<i>З з</i>	Z, z	Ч ч	<i>Ч ч</i>	Ch, ch
И и	<i>И и</i>	I, i	Ш ш	<i>Ш ш</i>	Sh, sh
Й й	<i>Й й</i>	Y, y	Щ щ	<i>Щ щ</i>	Shch, shch
К к	<i>К к</i>	K, k	Ъ ъ	<i>Ъ ъ</i>	"
Л л	<i>Л л</i>	L, l	Ы ы	<i>Ы ы</i>	Y, y
М м	<i>М м</i>	M, m	Ь ь	<i>Ь ь</i>	'
Н н	<i>Н н</i>	N, n	Э э	<i>Э э</i>	E, e
О о	<i>О о</i>	O, o	Ю ю	<i>Ю ю</i>	Yu, yu
П п	<i>П п</i>	P, p	Я я	<i>Я я</i>	Ya, ya

*ye initially, after vowels, and after ъ, ь; e elsewhere.
When written as ë in Russian, transliterate as yë or ë.

RUSSIAN AND ENGLISH TRIGONOMETRIC FUNCTIONS

Russian	English	Russian	English	Russian	English
sin	sin	sh	sinh	arc sh	sinh ⁻¹
cos	cos	ch	cosh	arc ch	cosh ⁻¹
tg	tan	th	tanh	arc th	tanh ⁻¹
ctg	cot	cth	coth	arc cth	coth ⁻¹
sec	sec	sch	sech	arc sch	sech ⁻¹
cosec	csc	csch	csch	arc csch	csch ⁻¹

Russian English

rot curl
lg log

GRAPHICS DISCLAIMER

All figures, graphics, tables, equations, etc. merged into this translation were extracted from the best quality copy available.

DOC = 83120701

PAGE 1

HYDRAULIC PRESSES.

B. V. Rozanov.

Page 2.

In the book description of the principles of the work of hydraulic presses with the contemporary systems of drive, analysis and calculation of their basic parameters is given. The short description of constructions/designs and characteristic of forging, stamping, blanking, bar-pipe and other presses is given. Are presented the methods of calculation of the dynamics of press and strength of its basic parts - cylinders, columns, cross-beams, etc.

The book is intended for the design engineers of hydraulic press equipment, the mechanics of press rooms, instructors, and also it can be used by the students of old courses on the specialty "working of metals by pressure".

Page 3.

Chapter 1.

BASIC CONCEPTS AND GENERAL ARRANGEMENT.

DEFINITION OF THE PRESS AND SCHEMATIC DIAGRAM OF ITS SYSTEM.

The implement of static action is called hydraulic press. The effort/force, developed with press, is created with the aid of high-pressure liquid (water emulsion or mineral oil). Are applied presses for working of the metals and other materials by pressure, for the installation works, for testing of assemblies and machine parts and other works.

The action of hydropress is based on what in the closed hydraulic system the pressure of liquid everywhere and in all directions of virtually identical.

The schematic diagram of the device of press is given in Fig. 1.

Working cylinder 1 with plunger 2 is imparted with the aid of conduit/manifold 3 through control system by 4 with drive 5, which creates the flow of working fluid under the specific pressure. With the working stroke the liquid presses to the plunger, which transmits effort/force to crosshead 6, which bears instrument 7 for the treatment of material.

The displacement/movement of cross-beam to the initial position, after working stroke, is accomplished/realized by plungers of 8 cylinders of recurrent course by 9. Working and pull-backs are installed in the mounting of press 10, whose construction/design is

determined by designation/purpose and power of press.

Liquid in the hydropress serves for the transfer of energy produced by drive operating mechanism - hydraulic cylinder. The use of a liquid for the energy transfer up to the distance without the use/application of lever/crank and other mechanical systems gives the possibility to construct the implements, simple by the construction/design, which develop large working efforts/forces and having large working spaces.

Contemporary presses are constructed with the efforts/forces from several kilograms (laboratory presses) to tens of thousands of tons (stamping machines). The sizes/dimensions of the working tables of powerful/thick stamping machines are measured by meters.

Presses depending on designation/purpose, developed effort/force and many other factors have different design.

The arrangement of cylinders and the type of mounting are the most characteristic features of the construction/design of press.

Page 4.

According to the first sign/criterion the presses are divided

into the vertical ones (Fig. 2) and the horizontal ones (Fig. 3).

The mountings of presses perform column construction/design (Fig. 2, 4) or by frame (Fig. 5 and 6).

Columns usually serve as guides for mobile crosspieces. The presses are constructed with different number of columns; are most widely used corner post-type presses.

The frame mountings of presses are performed by two-strut ones and single-column ones; the latter are commonly used in the presses of small effort/force and when unobstructed approach to the press from three sides is required and a good review of working space. Two-strut mountings have more rigid construction/design, good direction of the crosshead and are applied mainly in the presses, intended for the precision stamping.

Vertical presses are performed with the working cylinders, arranged/located above or below mounting. In presses with the lower arrangement of cylinders the cylinders of recurrent course usually are not required; return to the initial position of the moving elements of the press occurs under the action of their dead weight.

Pull-backs are furnished either in the crown, or in the lower.

During the arrangement of pull-backs in the upper fixed cross-beam the connection of their plungers with the crosshead is accomplished/realized differently: either by the rods/thrusts, connected directly with the plungers (Fig. 6c) or by the rods/thrusts through the special cross-beam (see Fig. 2a).

Presses are distinguished also by a number of working cylinders, moreover a number of latter is determined by different requirements.

The presses, which develop large efforts/forces, are constructed by multicylinder ones for the purpose of obtaining several steps/stages of effort/force or velocity due to the start of different number of cylinders, and also reduction of the overall dimensions of press (overall dimensions of cylinders themselves, cross-beams, etc.). A quantity of working cylinders is also frequently determined by the designation/purpose of press.

Depending on technological designation/purpose, the presses have different auxiliary devices, which include extensible or swivel tables, devices for the knockout of the stamped parts, chargers, hoists, etc.

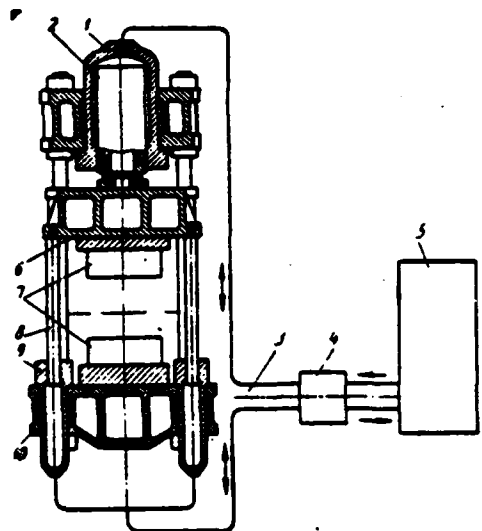

Fig. 1. Schematic diagram of the device of hydraulic press.

Page 5.

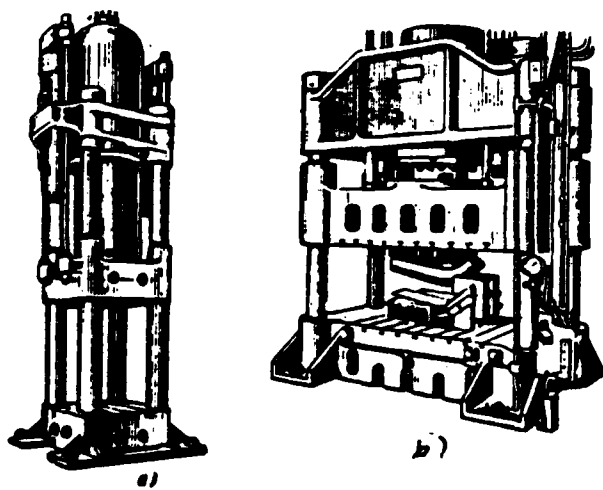

Fig. 2. Vertical corner post-type presses: a) piercing; b) stamping.

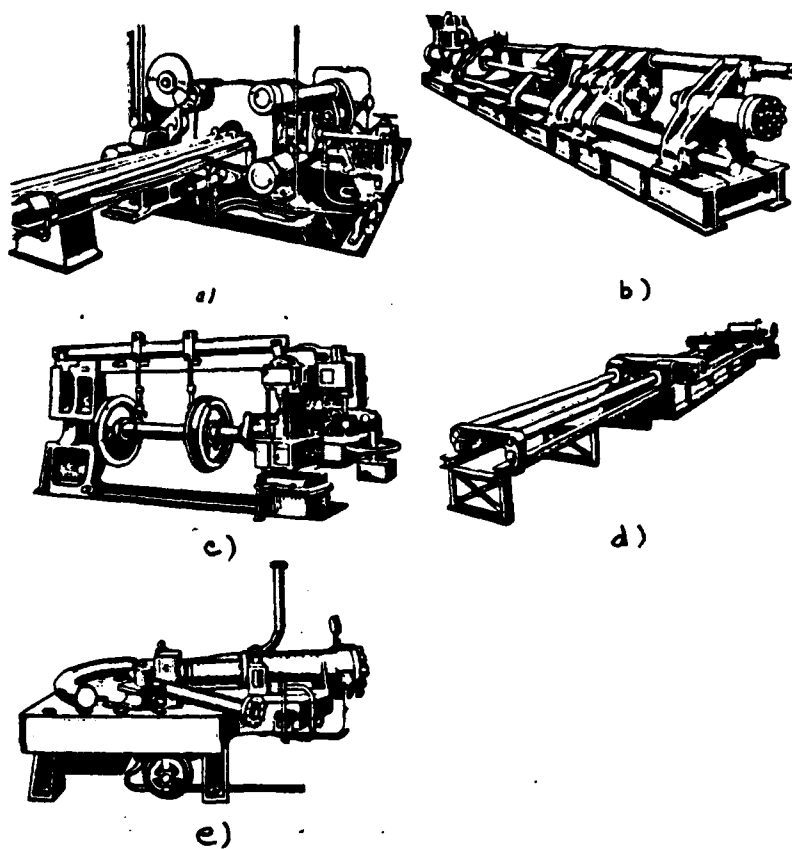

Fig. 3. Horizontal presses: a) bar-tube; b) drawn-out; c) wheel; d) correct-stretching; e) tube-bending.

Page 6.

The detailed description of the constructions/designs of the presses of different designation/purpose is given in Chapter 2.

As the drive of press apply mainly plunger high-pressure pumps,

also, in the rare cases multistage centrifugal pumps. For presses with the small efforts/forces and for the auxiliary devices of large/coarse presses blade, spiral and gear pumps are applied also.

For the purpose of a decrease in the power of the electric motors of the drive of powerful/thick high-speed presses, and also for the group press installations are applied the storage batteries/accumulators of high-pressure liquid (pump-and-battery drive).

Besides the pumps, for the drive of some types of the presses, for example, forging and stamping (Chapter 2), are applied also simple devices - the multipliers, which work with the aid of vapor, compressed air, the electric pump or the electromechanical transmission.

Multipliers are applied also in the presses, which work from pumps with the storage battery/accumulator, for the pressure increase of the working fluid, which comes the press.

In hydraulic press the complete cycle of work is divided into the idle, the worker and recurrent of the course by mobile they are transverse to the operation of auxiliary mechanisms. In this case those indicated of stroke of press can be accomplished/realized with

the aid of different drives.

The majorities of presses for the realization of idling have filler tanks with low-pressure liquid. The filler tanks are made closed, liquid in which is under pressure the compressed air, or opened, adjustable are higher than the level of working cylinder. Together with the filler tanks for the realization of idling the cylinders of low diameter and the low-pressure pumps are applied also.

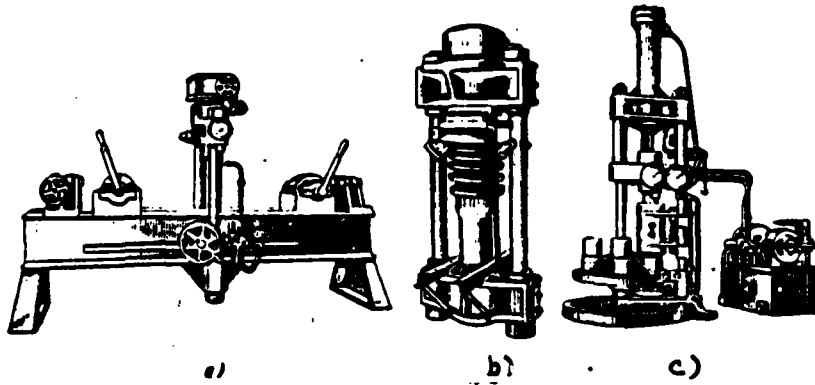

Fig. 4. Vertical two-column presses: a) correct; b) squeezing; c) experimental.

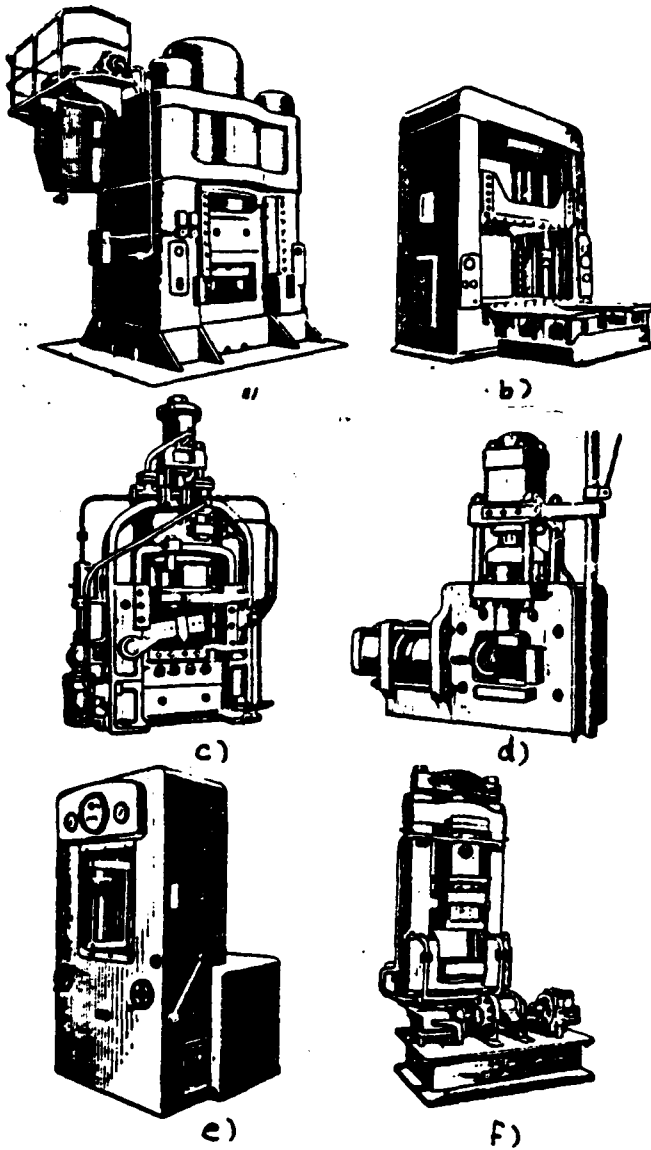

Fig. 5. Vertical presses with the frame two-strut mounting: a) stamping; b) for the control/check of the figure of dies/stamps; c) shear press; d) spring; e) for, the extrusion/pressing dry ice; f) for the extrusion/pressing of articles made of the plastics.

The schematic diagrams of the drive of presses are shown in Fig. 7-11. The most varied combinations of the elements/cells of drive, given on these diagrams, are possible.

As the working fluid in the hydropresses is applied mineral oil (pumping drive) or emulsion - water with the solution/opening in it 2-3% of soluble oil (pumping, pump-and-battery and multiplier drives).

Good results gives use/application of soluble oils of the following composition: 83-87% of mineral oil (spindle, machine, solar, transformer); 12-14% of oleic acid and 2.5% of the sodium hydroxide by stability 40% or 82-84% of mineral oil; 14-16% of acidol of the waterless and 1.5% forty percent solution/opening of the caustic soda.

The pressure of working fluid in the presses is taken as the equal to 200 kg/cm² during the pumping drive, 200-320 kg/cm² - during the pump-and-battery drive and 400-450 kg/cm² - during the use/application of multipliers.

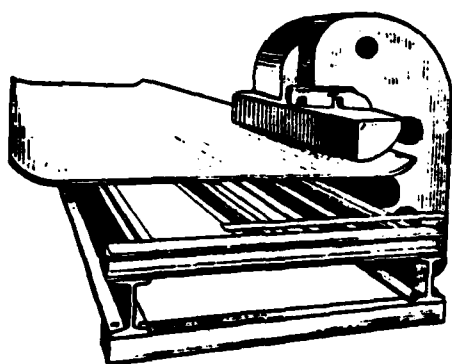

a)

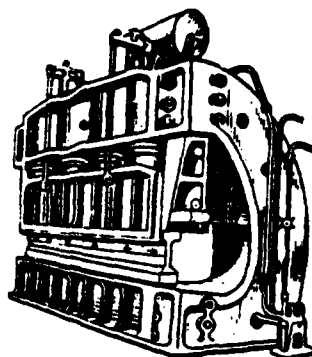

b)

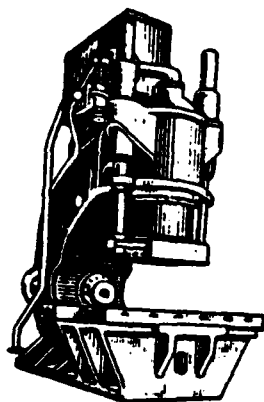

c)

Fig. 6. Vertical presses with overhanging: a) for the bending under of the edges of sheets; b) bending; c) blanking.

Page 9.

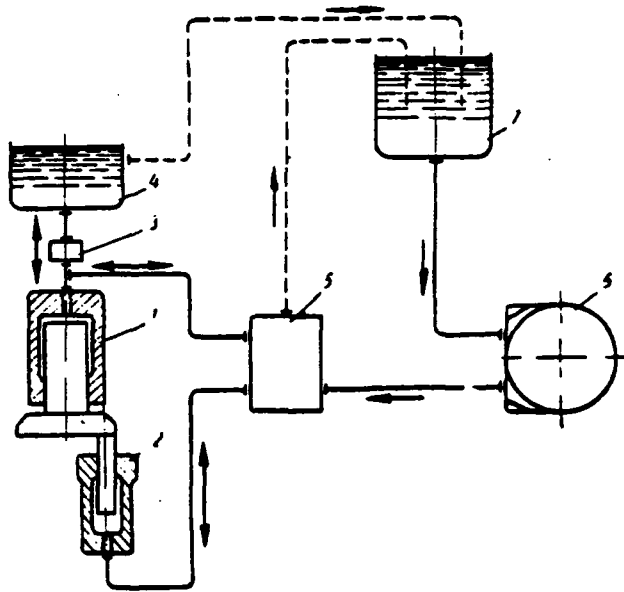

Fig. 7. The schematic diagram of press with the pumping drive: 1 - working cylinder; 2 - cylinder of recurrent course; 3 - filler valve; 4 - filler tank; 5 - controls of press; 6 - pump; 7 - pumping tank.

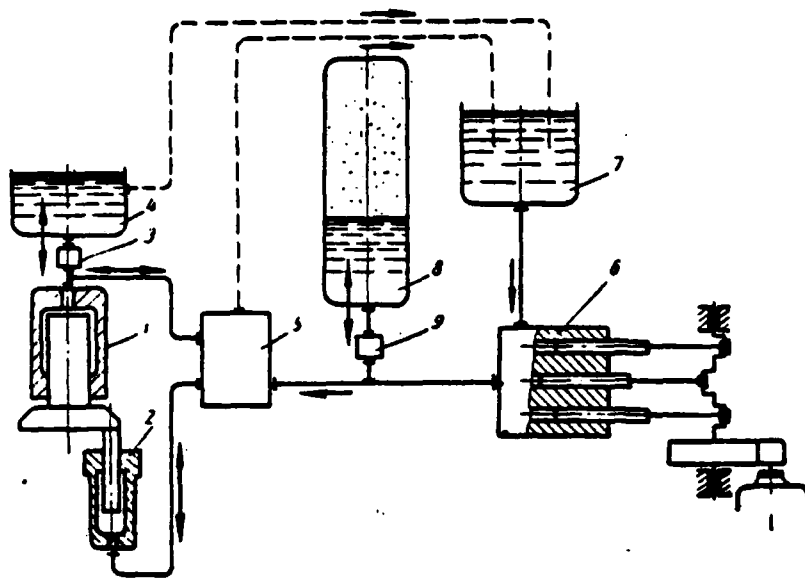

Fig. 8. The schematic diagram of press with the pump-and-battery drive: 1 - working cylinder; 2 - cylinder of recurrent course; 3 - filler valve; 4 - filler tank; 5 - controls of press; 6 - pump; 7 - pumping tank; 8 - storage battery/accumulator of high-pressure liquid; 9 - check valve.

Page 10.

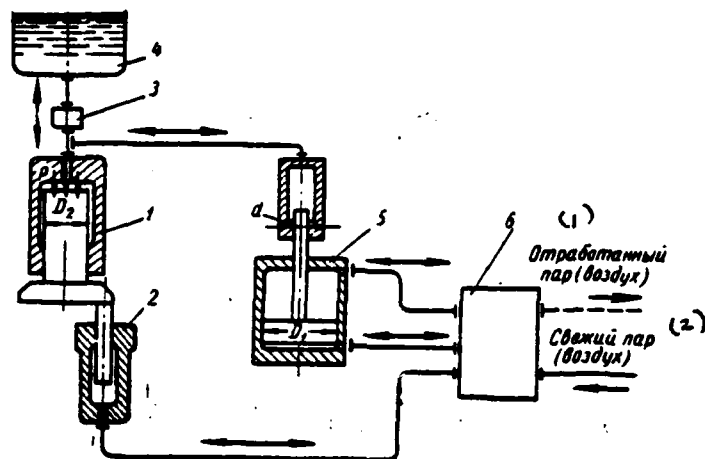

Fig. 9. The schematic diagram of press with the steam (air) multiplier: 1 - working cylinder; 2 - cylinder of recurrent course; 3 - filler valve; 4 - filler tank; 5 - steam (air) multiplier; 6 - controls.

Key: (1). the exhaust steam (air). (2). Live steam (air).

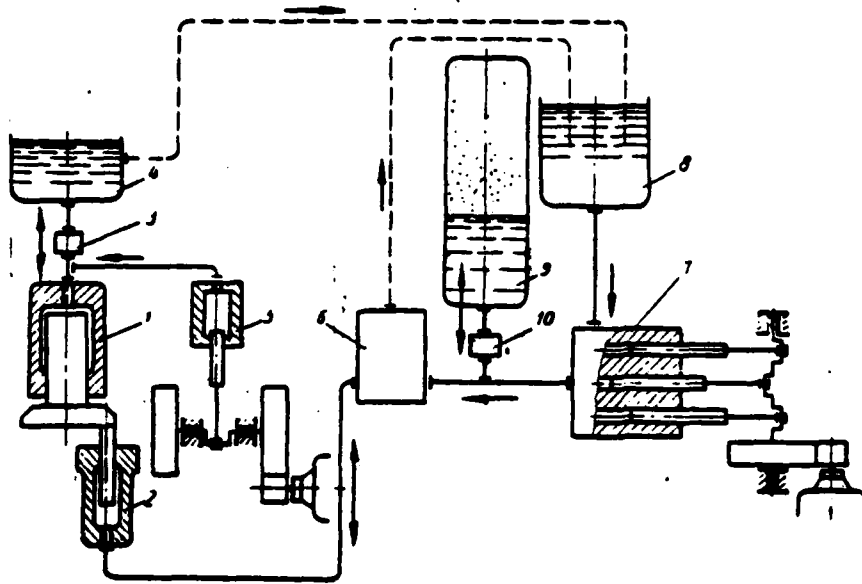

Fig. 10. The schematic diagram of press with the drive from the mechanical multiplier: 1 - working cylinder; 2 - cylinder of recurrent course; 3 - filler valve; 4 - filler tank; 5 - multiplier with the power drive; 6 - controls; 7 - pump; 8 - pumping tank; 9 - storage battery/accumulator of high-pressure liquid; 10 - check valve.

Page 11.

There are press installations, which work with higher pressure of working fluid, for example the presses of the system of Eng. V. A. Mikheev (Novosibirskiy the plant of heavy machine tools and hydro presses), in which with the aid of the built-in the cylinder

multiplier is created a pressure 1000-1200 kg/cm².

Fundamental Characteristics of Drives of Hydropresses.

Pumping batteryless drive of presses. During the pumping drive without the storage battery/accumulator of the liquid of the high pressure (see Fig. 7) of the velocity of plungers they have completely specific value, which corresponds of the supply of pumps, and pressure on the flange of pump corresponds to the effort/force, which affects on the crosshead.

The work, developed with pump, corresponds to the useful work, accomplished by press.

Pumping batteryless drive has high efficiency; its average/mean value at the working stroke in the contemporary presses composes 0.6-0.8.

During this drive it is easy to carry out electrical control by equipment and flexible control of press. Pressure in the drainage system accurately is checked.

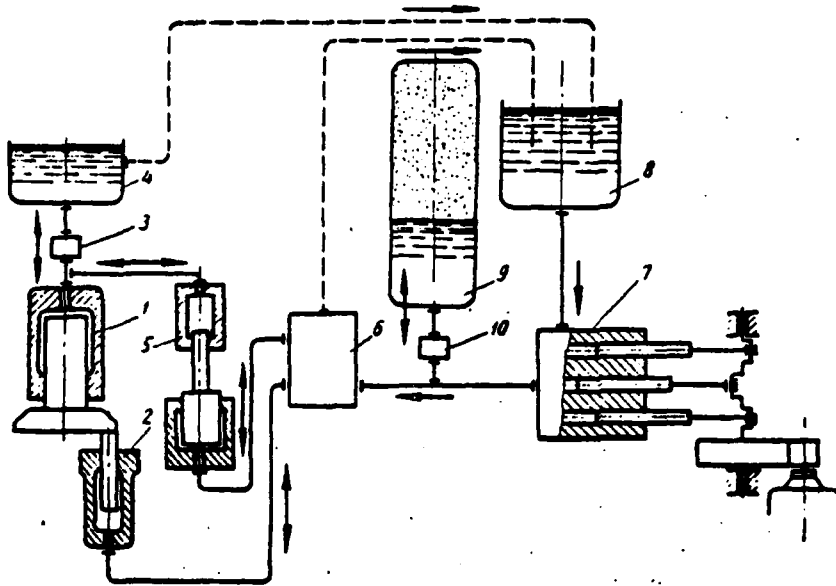

Fig. 11. The schematic diagram of press with the multiplier pump drive: 1 - working cylinder; 2 - cylinder of recurrent course; 3 - filler valve; 4 - filler tank; 5 - multiplier; 6 - controls; 7 - pump; 8 - pumping tank; 9 - storage battery/accumulator of high-pressure liquid; 10 - check valve.

Page 12.

The possibility of the control of pressure can be used for control of the press, i.e., maximum pressures in different operating cycles of press can be used as the impulses/momenta/pulses for switching of equipment for control. Hydraulic system is not found

constantly under pressure, which facilitates the operation of press. Drive has relatively small dimension and can be placed on the press itself - on its mounting.

Together with the advantages indicated batteryless pumping drive has the deficiency, that lifting power during this drive is selected by the maximum power of press.

For the presses, which develop large efforts/forces and workers with the high velocities, lifting power prove to be exaggerated.

The power of the engine of pump usually also is designed from the maximum power of press, since during the batteryless pumping drive high-speed pumps, directly connected with the shaft of electric motor, are mainly used. mainly. Flywheels on the high-speed shafts are established/installed river as a result of the need precise balancing/trimming of flywheel.

The operating speed of the crosshead of press during the pumping drive rarely exceeds 50 mm/s; a number of working strokes in small presses composes 15 per minute approximately.

Presses with the efforts/forces 250-500 t with course of cross-beam, equal to approximately 1 m, are constructed with a number

of courses by 8-10 per minute, while presses with the effort/force to 1000 m with the same value of course - with a number of courses by 5-7 per minute.

For the best use of adjusting power of engine and, thus, increase numbers of strokes of press are constructed with several steps/stages of velocities and efforts/forces.

Several steps/stages of efforts/forces and velocities of press with its drive from the pump of constant supply to working fluid it is possible to obtain by the use/application of several (usually three) working cylinders. Directing the flow of oil from the pump into one, two or are more than cylinders, we will obtain different velocities and efforts for the individual sections of stroke of press.

After selecting on the prescribed/assigned forces and the selected pressure of the area of plungers, that affect in the appropriate sections of working stroke, it is possible to increase considerably the use of a pump and engine and to reduce the time of the working stroke of press.

Analogous effect can be obtained by the use/application of several pumps with different characteristics.

In the press installations two pumps most frequently are applied, moreover their drive frequently is accomplished/realized from one engine. In this case it is necessary to attempt to select the parameters of pumps in such a way that the engine would develop constant power at entire working course.

In presses designated for the specific technological operations, with the implementation of which the force sharply grows/rises at the end of the working stroke, and on the larger part of it remains considerably less than the maximum, the use/application of a pump with the variable/alternating/variable supply is expedient.

Pump-and-battery drive of presses. The presence in hydraulic system of the press of the storage battery/accumulator (see Fig. 8) allows/assumes consumption by the press of large amount of liquid in the relatively short time and, therefore, the work of press with the high velocities of working plungers.

Page 13.

The velocity of working stroke in the presses with the pump-and-battery drive reaches 500 mm/s.

The presence of storage battery/accumulator in the hydraulic system changes the fundamental characteristic of the pumping drive of press.

In presses with the storage battery/accumulator the velocity of the crosshead with the working stroke depends on the resistance overcome by it. Energy content, consumed by press for the working stroke, depends on the value of course and does not depend on the character of a change in the resistance, since press consumes the liquid of virtually constant pressure.

The efficiency of press with the storage battery/accumulator, which considers losses to fluid friction in the conduit/manifold and in the controls, has average/mean value, many times lower in comparison with the press, which has batteryless pumping drive. The lower the value of it, the crosshead of press overcomes the less resistance.

When load is absent, entire/all energy, loosened by storage battery/accumulator, is expended/consumed mainly on overcoming of the frictional resistance of liquid in the conduit/manifold.

The velocity of the steady motion of liquid in the conduit/manifold about the absence of the resistance to motion of the crosshead can inadmissibly increase, as a result of which during the subsequent abrupt deceleration flow in the system the hydraulic impact of large force will arise. Therefore the conduits/manifolds of presses with the storage battery/accumulator are projected/designed with the artificially overstated resistance of hydraulic system.

Energy loss to the deformation of system (liquid, mounting, etc.) is twice more as during the pump-and-battery drive in the comparison with the losses during the batteryless pumping drive.

Thus, the pump-and-battery drive has relatively low efficiency or is uneconomical.

Multiplier drive of presses. The multipliers, used for the pressure increase of working fluid and its supply into cylinders of press, allow by themselves either the devices, which consist of the cylinders of different diameters (see Fig. 9), or the single-piston pumps (see Fig. 10) with the drive of plunger from the electric motor through the mechanical linkage (crank and connecting rod assembly, rack mechanism, worm-and-worm wheel and the progressively/forwardly moving/driving screw/propeller, given by this pair).

In the first case low-pressure cylinder is fed either by steam or by air (steam-air multipliers), or by liquid from the pump-and-battery station or the low-pressure pump.

The basic parameters of the steam-air and connected to the pump-and-battery station multiplier are designed from prime formulas (designations see in Fig. 9).

Page 14.

The pressure, developed with the multiplier:

$$p = \frac{D_1^2}{D^2} p' \eta_m,$$

where p' - pressure of the working medium (vapors, air, water, etc.), supplied to low-pressure cylinder, in kg/cm^2 ;

η_m - mechanical efficiency of multiplier.

The course of working transfer plunger, which corresponds to one course of the multiplier:

$$S = \frac{d^2 s}{D^2} \eta_o.$$

where S - stroke of press in cm;

s - course of multiplier in cm;

η_v - volumetric efficiency of system (high-pressure cylinder of the multiplier - working pressure cylinder), which considers the losses of liquid to the leaks/leakages, and also its compression in the cylinders and the conduit/manifold.

With the feeding of multiplier from the pump with the supply, equal to Q, the amount of liquid, supplied with multiplier to the press, comprises

$$q = Q \frac{d^3}{D_1^3} \eta_v,$$

and respectively the velocity of transfer plunger will be

$$v = \frac{4000}{\pi} Q \left(\frac{d}{D_1 D_2} \right)^3 \eta_v.$$

where d, D₁, D₂ - in cm, Q - in l/min and v - cm/min.

At the power drive of the plunger of multiplier its basic parameters (supplies, the velocity of motion, power, etc.) depend on the character of transmission from the engine to the plunger.

The steam-air multipliers had extensive application for the forging high-speed presses. However, as a result of their low operational efficiency/cost-effectiveness, caused by the fact that

vapor (air) in them works without the expansion, and also the presence of large losses due to condensation the vapor and the losses of vapor or air to the leaks/leakages, the steam-air multipliers are extruded by pumping and pump-and-battery drives.

Multipliers during the pump-and-battery drive are applied in the powerful/thick stamping ones in the single-cylinder and two-cylinder forging presses for obtaining the additional pressure stage.

Multipliers with the power drive (see Fig. 10) are applied for the drive of forging presses with the effort/force to 6000 t; however, as a result of their large dimensions they did not receive wide acceptance.

Multipliers with the feeding from the pump (usually centrifugal) have limited application for the presses with the low working course.

Page 15.

Distinctive Special Features and Fields of Efficient Use of a Hydropress.

Hydraulic presses found use for the realization of the most varied technologically processes and in many instances extrude other

machines as, for example, mechanical presses and steam-air hammers. This is explained by a number of positive special features/peculiarities of hydraulic press, which escape/ensue from the schematic diagram of its device.

Hydraulic press is the simplest implement, which can be constructed with the large developed efforts/forces and with the large working spaces. At present there are stamping machines, which develop effort/force 30000, 45000 t and more, while the most powerful/thickest existing mechanical press develops effort/force 10000 t. The most powerful/thickest common steam air swage hammer is equivalent to a press of 30000 t, if we accept equivalent - 1000 t of the effort/force of press it corresponds to 1 t of the weight of the falling/incident parts.

Counterblow hammers are the exception. However, hammers virtually cannot be constructed for stamping the large-size parts.

Contemporary machine building needs the machines, which develop the effort/force, equal to ten thousand tons, for stamp of the parts with a length of more than 10 m. The creation of powerful/thick mechanical (crank or eccentric) press with the large sizes/dimensions of stamp space is connected with the difficulties of manufacturing the elements/cells of its drive and mounting.

Hammers are the machines of percussion; one of the main parameters, which are determining the power of hammer, is the mass of the falling/incident parts - mass of ram. So that the ram would be sufficiently strong, its mass must be concentrated in the minimum volume, i.e., have minimum overall dimensions; it cannot be carried out in the form of beam/gully (box-shaped or other form of section/cut), similarly how the crossheads of hydraulic presses for stamping the large-size parts are performed.

The swage, equivalent to forging press by effort/force 15000 t, must have a weight of ram, equal to about 100 t.

Contemporary forging hydraulic presses are constructed with the efforts/forces to 15000 t, and already is a necessity for the presses with the large efforts/forces, while the swages are not constructed with a weight of the falling/incident parts of more than 8 t.

Thus, for forging and stamping the large-size parts the use/application of a hydraulic press is the most rational solution.

Hydraulic presses are also simplest machine-tools, which can be constructed with the large course of instrument.

For the manufacturing of many hollow parts by the method of broach the presses with the efforts/forces to 2000 t and the course of cross-beam to 12 t are constructed.

Page 16.

For the hot die forging of large-size parts from the sheet (for example, the half-rims of the boilers with length to 10 m and bottoms with a diameter of more than 3 m) are required the implements with the efforts/forces to 10000 m, with the large working spaces, and for these purposes hydropresses are preferable also.

The developed with hydraulic press effort/force completely definitely, and, thus, is eliminated the possibility of its overloading, for example, with flashless die forging of blanks, it is insufficient those heated, or blanks with the sizes/dimensions large against the calculated ones, and also is facilitated die setting during the stamping into the "detent".

Hydraulic presses virtually replaced all mechanical presses for the packing and briquettings of different materials, since as a result of the absence of the "rigid" course of the cross-beam of

press and certainty of the maximum effort/force, developed with press, there is not required a precise metering of the material, which enters for the extrusion/pressing.

In the hydraulic press the velocity of plunger is easily regulated by a change in the amount of liquid, supplied per unit time into the working cylinder. With the idle (without the load) and recurrent courses the velocity is established/installed considerably higher than velocity of working stroke, which in combination with the control of the value of complete piston stroke gives the possibility to have different rapidity of press depending on the sizes/dimensions of workpiece and required value of working stroke.

For example, punch press during the drawing of shallow part can work with a large number of courses, during the drawing of deep parts - with smaller, in this case there is required no readjustment of press. Simplicity of construction/design, possibility of obtaining of large efforts/forces, large working courses and ease/lightness of speed control over wide limits make it possible to consider hydropresses irreplaceable for the extrusion/pressing of ducts/tubes/pipes and complicated profiles/airfoils from the nonferrous alloys, and at present they begin extensively to be used for the extrusion/pressing of ducts/tubes/pipes and profiles/airfoils from the low-plastic alloys.

In the hydraulic press working plunger can accomplish the course of variable quantity; in this case the maximum effort/force, developed with plunger, can be obtained on any part of it course.

The effort/force, developed with plunger, at any point of course easily is determined on the pressure, indicated by the manometer, connected with the hydraulic system. Therefore it is expedient to conduct experimental stamping in the mass productions for the purpose of the determination of the parameters of process and adjustment of technology and instrument on the hydraulic presses.

In the hydraulic press constant effort for the crosshead can be supported at its positive seat during any time interval. For this reason such processes, as the cementing of plywood, stamping parts from the plastics, squeezing of oils, vulcanization of rubber articles and many others, are produced only on the hydraulic presses.

Page 17.

As a result of the special features/peculiarities indicated hydraulic presses are applied for testing of ducts/tubes/pipes, testing for strength of different articles, for the

extrusion/pressing of loose materials, for any kind of installation works (assembly of springs, nozzle of wheels on the axis/axle, riveting/stave, etc.), for bending of ducts/tubes/pipes, greasing of the electrodes, lead plating of cable and for many other processes.

Together with the positive special features/peculiarities hydraulic presses have their shortcomings, as a result of which their use/application in many instances is irrational. These shortcomings are the following.

Hydraulic press is relative to slow-speed machine both on the velocity of the motion of instrument and along a number of courses per unit time.

Idling speed in vertical presses rarely exceeds 300 mm/s. The possibility of a considerable increase in the idling speed is limited by the following factors.

The foundations of hydraulic presses are usually designed only for the dead weight of press with the relatively small coefficient of dynamicity.

In actuality in the transient mode/conditions from the idle to the working stroke vertical press works as hammer, since the

effort/force during the crosshead during the forging or the stamping at the very beginning of working stroke virtually always has finite value and, as a result of the large elasticity of liquid (modulus of elasticity of water $E=2 \cdot 10^4$ kg/cm²), the velocity of the mobile cross-beam before beginning extrusion/pressing falls almost up to zero.

Thus, entire/all accumulated by the moving elements of press kinetic energy is transformed into the work of deformation. In other words, at the end of idling occurs the impact/shock of face or die/stamp on the blank. Therefore with the wish to raise idling speed it would be necessary to establish/install presses to the massive bases/roots. Since the presses are applied mainly when large working spaces are required, they have large dimensions in the plan/layout and, thus, the execution of the base/root of press by massive ones meets technical difficulties.

In vertical hydraulic press the center of gravity is usually located high above the foundation level and the upper cross-beam, in which working cylinders are placed, it has large mass. With the eccentric repeating impacts/shocks with the larger velocity occurs swaying the press, as a result of which the loads on the foundation sharply grow/rise and rapidly are disturbed/detuned the connections of conduits/manifolds.

The maximum speed of working stroke in the hydropresses usually 2.5-3 times of less than the idling speed and in the existing presses is limited by the hydrodynamic phenomena, which occur in the hydraulic system, i.e., by the hydraulic impact and by the cavitation flow conditions of liquid in the valves.

The speed of recurrent running of the crosshead is accepted usually equal idling speed.

Page 18.

With the sharp stop of the rapidly moving crosshead in the upper situation, when the center of gravity of press has highest position, in the reverse cylinders there appears a fluctuation of pressure, which calls swaying press.

The velocities of the motion of the crosshead, and first of all its velocity in the period of recurrent course, are limited also by the fact that the majority of powerful/thick presses has the manual control, during which are difficult to carry out smooth start and stop of the moving elements, which have large weight.

Besides the relatively low velocities of motion, are other factors, which lengthen the cycle time of the work of press. Hydraulic press is reversing engine. With the reversibility of movement for each cycle the time is expended on dispersal/acceleration and braking of moving elements.

Control of press, i.e., switching from the working stroke to the recurrent, consists of the alternating connection of cylinders to the working high-pressure line and to the drain line. Switching distributors, which is accomplished/realized with the aid of the valve or slide-valve devices, depending on construction/design and power of press, occupies 0.1-0.5 s. and more.

For the creation of the pressure of liquid in the working cylinders the relatively long time is expended, which also lengthens the time of one cycle.

At the termination of the working stroke of presses it stocks the relatively high energy, spent for the deformation of its parts, and also for the compression of liquid in the working cylinder.

Usually during the stamping or the forging the system of press is deformed from the eccentrically arranged/located load. Columns are bent, the large masses, placed at the ends of the columns, differ

from their initial position.

During the rapid unloading of press (unloading master cylinders from the pressure) the onset of oscillations of large masses is unavoidable. These oscillations additionally load foundation, and also disturb/detune the attachments/connections of conduit/manifold to the cylinders. In addition to this, the frequency of these oscillations is commensurated with the frequency of the work of press.

The considerations indicated force to produce unloading cylinders relatively slowly, at first throwing off water from the cylinder through the valve with the low flow area.

Time for unloading of cylinders from the pressure also lengthens the cycle time of the work of press.

The low speed of hydraulic presses narrows the region of their use/application. They cannot compete with the mechanical presses, when high productivity is required.

In the hydraulic press, as in another any machine, the part of input energy is expended/consumed on overcoming of forces of friction, which appear in motion rods. But, in addition to this, the

press has its specific losses, to which first of all should be related losses to fluid friction in the conduit/manifold, and also losses, caused by the relatively high elasticity of the liquids, which in certain cases can prove to be considerable.

Page 19.

For the creation in the hydraulic system of the press of the necessary pressure is required the supply of additional amount of liquid under the pressure, equal to

$$\Delta Q = Q \frac{p}{E}.$$

where p - operating pressure in the hydraulic system of press;

E - modulus of elasticity of system;

Q - quantity of the elastocompressible liquid.

A quantity of compressible liquid is composed of the liquid of that constantly locating in the system, i.e., by that filling conduit/manifold from the pressure valve to working cylinder (Q'), and the liquid, supplied to the system during the period of idle and worker of courses.

The work, spent on the compression of liquid during the pumping batteryless drive, is equal to

If we express Q through the effort/force, developed with press P , and piston stroke, then we will obtain

$$\Delta A = \frac{P(H_x + H_p)p + Q'p^3}{2E},$$

where H_x and H_p — respectively the value of idle and worker of piston strokes.

From this expression it follows that the greater the idling of press, the greater the loss in the press for the elastic compression of liquid. In the presence in hydraulic system of storage battery/accumulator these losses are doubled.

Therefore is irrational the use/application of hydropresses for the technological operations, which require relatively short working courses as, for example, for the coining works.

For reasons of the efficiency/cost-effectiveness of the operation of press an increase in the operating pressure in the press is also irrational, since losses on the elastic compression of liquid are directly proportional to pressure.

Page 20.

Chapter 2.

CONSTRUCTIONS/DESIGNS CHARACTERISTICS OF THE PRESSES OF DIFFERENT
DESIGNATION/PURPOSE.

Forging presses.

Forging forgings from the ingots and the rolled blanks with a diameter of 200-3000 mm is produced on the hydraulic presses, which are constructed with the efforts/forces 300-15000 t. Presses with the efforts/forces 750-3000 t are most widely used.

The effort/force of press for forging of steel parts is selected

according to experimental data (Table 1) or according to the approximate computations, which consider weights and sizes/dimensions of blanks or ingots, which are selected by the maximum sizes of forgings taking into account the necessary degree of reduction. The latter oscillates, depending on material and designations/purposes of forgings, from 2 to 6, counting according to the ratio of the areas of blank to the finished forging.

The calculation of effort/force is produced according to the formula

$$P = \frac{Fq}{\eta}$$

where F - working surface of instrument (face, broach, etc.) in mm^2 ;

q - specific resistance to deformation of metal during the forging in kgf/mm^2 ;

η - efficiency of press.

The resistance to deformation of structural carbon and light-alloyed steels with the basic forging operations (upsetting and drawing in) according to experimental data comprises not more than 15 kgf/mm^2 .

During the calculation of effort/force for forging of the small

rapidly cooling off forgings the high values of the resistance to deformation are accepted. With the piercing of the holes, when metal has the capability of free flow to the sides, the resistance to deformation is received equal to 12-15 kgf/mm², also, during the limitation of the flow of metal (piercing in the ring, etc.) - 20-30 kgf/mm². The efficiency of press, which considers losses to fluid friction in the conduit/manifold and the distributors, and also in the plunger guide, cross-beams, etc., is taken as equal to $\eta=0.7-0.8$.

Page 21.

Working the effort/force of press to a considerable degree also depends on the form of the faces used and finished forging.

During forging of ingots are applied flat/plane or notched strikers or their combination: flat/plane upper and carved lower. During the forging in the notched strikers required effort/force considerably grows/rises.

The process of forging the parts of intricate shape is composed of many characteristic operations, which are determining requirements for the construction and parameters of forging press.

Is working the space of press must be surveyed well from all

sides; must be access to the finished forging for the imposition of instrument (axe, unrolling), and also for size measurement in the process of forging. Therefore forging presses are performed with four-roll or overhanging. The corner post-type presses, which have the widest use, are constructed with the efforts/forces 500-15000 t and single-column to 1200 t. Single-column presses are applied for forging of the small, but complex-shape on the configuration forgings, during manufacture of which free access to the faces from three sides of press is required.

The basic dimensions of press must correspond to the effort/force, developed with press, and to the sizes/dimensions of the ingot, which can be on it forged.

The maximum clearance between the lower plate/slab and the mobile transverse of press is determined by the height/altitude of blank of the ingot maximum by weight for this press.

Table 1. Tentative given for the selection of forging presses and their comparison with the hammers.

(1) Диаметр слитка или заготовки в мм	(2) Усилие пресса при ковке в т		(5) Потребный вес пада- ющих частей молота в т
	(3) без осадки	(4) с осадкой	
120	100	—	0.5
150	150	—	0.75
200	200	—	1.0
250	300	—	2.0
400	400	—	3.0
400	500	800—1 000	4.0
500	800	1500	7.0
800	1 000	2000—2500	10.0
1000	1 500	3000	20.0
1250	2 000	5000	40.0
1450	2 500	6000	60.0
1500	3 000	8000	80.0
1750	4 000	8000—10 000	120.0
2000	5 000	—	—
2 000	6 000	—	—
2300	8 000	12 000	—
2300—2500	10 000	—	—
2750	12 000	15 000	—
2800—3000	15 000	—	—

Key: (1). Diameter of ingot or blank in mm. (2). Effort/force of press during the forging in t. (3). without upsetting. (4). with upsetting. (5). Required weight of the falling/incident parts of the hammer in t.

Page 22.

Stroke of press is selected, on the basis of the value of upsetting, which usually oscillates from 30 to 60% of initial height/altitude of ingot. The size/dimension between the columns in the light/world along the wide side of press must be sufficient for the free pass of

the forging, maximum in the width, finished forging on the press. The size/dimension between the columns along the narrow side is usually selected of the stability condition and rigidity of the frame of press equal to 0.35-0.5 of distance along the larger side. This size/dimension between the columns and respectively also the size/dimension of upper cross-beam in the width must be made as smaller as possible so that it would be possible to nearer feed forging tap/crane to the press, which is especially substantial with the upsetting of ingot.

The size/dimension of the lower cross-beam of press along the narrow side of columns must be sufficiently large for the possibility of the installation/setting up on it of supports during forging of rings on the mount/mandrel.

Forging presses usually are constructed with the extensible tables, the value of course of which is established/installed from the calculation of the necessary advancement of the upset ingot from under the press to the tap/crane. Effort/force for displacing the table is taken as the equal to 2-6% of the nominal effort/force of press. For the knockout of forgings with upsetting in the ring, in the lower cross-beam, and sometimes also from the side the press in the center of extensible table in its end advanced position is provided for the knockout, whose effort/force is taken as the equal

to 2.5-6% of the nominal effort/force of press.

The power parameters and the dimensional characteristics of contemporary corner post-type forging presses are given in Table 2, the exemplary/approximate dimensions of single-column (steam-hydraulic) presses are shown in Fig. 12.

Table 2. Exemplary/approximate characteristics of corner post-type forging presses.

(1)	(2)	(3)	(4)	(5)	(6)		(7)	(8)	(9)	(10)	(11)	(12)	(13)
Номинальное усилие пресса в т	Максимальный ход подвижной поперечины в мм	Максимальное расстояние между столешницей и подвижной поперечной в мм	Расстояние между колоннами в свету в мм	Размеры выдвижного стола в мм	Ход стола в мм		Усилие цилиндров стола в т	Усилие выталкивателя в т	Ход выталкивателя в мм	Ориентировочная высота пресса над полом в мм	Приблизительный вес пресса в т		
					одностороннего	двустороннего							
500	800	1600	1180	1800—950	1100	—	10	30	600	5000	50		
800	1000	2000	1500	2000—1100	1100	—	16	40	700	6000	90		
1250	1250	2500	1900	2200—1150	1200	—	16	50	750	6500	110		
1500	1400	2800	—	2200—1500	1200	—	20	65	900	7500	170		
2000	1600	3200	2360	2800—1800	1500	—	30	80	1000	8500	250		
2500	1800	3550	—	3400—2000	1800	—	40	100	1000	900	320		
									125				
3200	2000	4000	3000	6000—2100	—	4500	110	150	1200	10000	400		
4000	2200	4100	—	6000—2550	—	4500	125	200	1300	11000	600		
5000	2500	5000	3750	6000—2800	—	4500	150	200	1300	12000	850		
6000	2600	5000	—	8000—3200	—	6000	180	225	1300	13000	1100		
8000	2800	6000	—	8000—3600	—	6000	200	250	1500	14000	1600		
10000	3000	6500	—	10000—4000	—	7000	250	250	1500	15000	2100		
12000	3200	7000	—	10000—4200	—	7000	280	300	1500	15500	2900		
15000	3400	7500	—	10000—4200	—	7000	300	375	1500	16000	3400		

Key: (1). Nominal effort/force of press in t. (2). Maximum course of the crosshead in mm. (3). Maximum distance between the table and the mobile transverse in mm. (4). Distance between the columns in the light/world in mm. (5). Sizes/dimensions of extensible table in mm. (6). Course of table in mm. (7). one-sided. (8). bilateral. (9). Effort/force of the cylinders of table in t. (10). Effort/force of ejector in t. (11). Ejection stroke in mm. (12). Tentative height/altitude of the press above the floor/sex in mm. (13). Approximate weight of press in t.

Page 23.

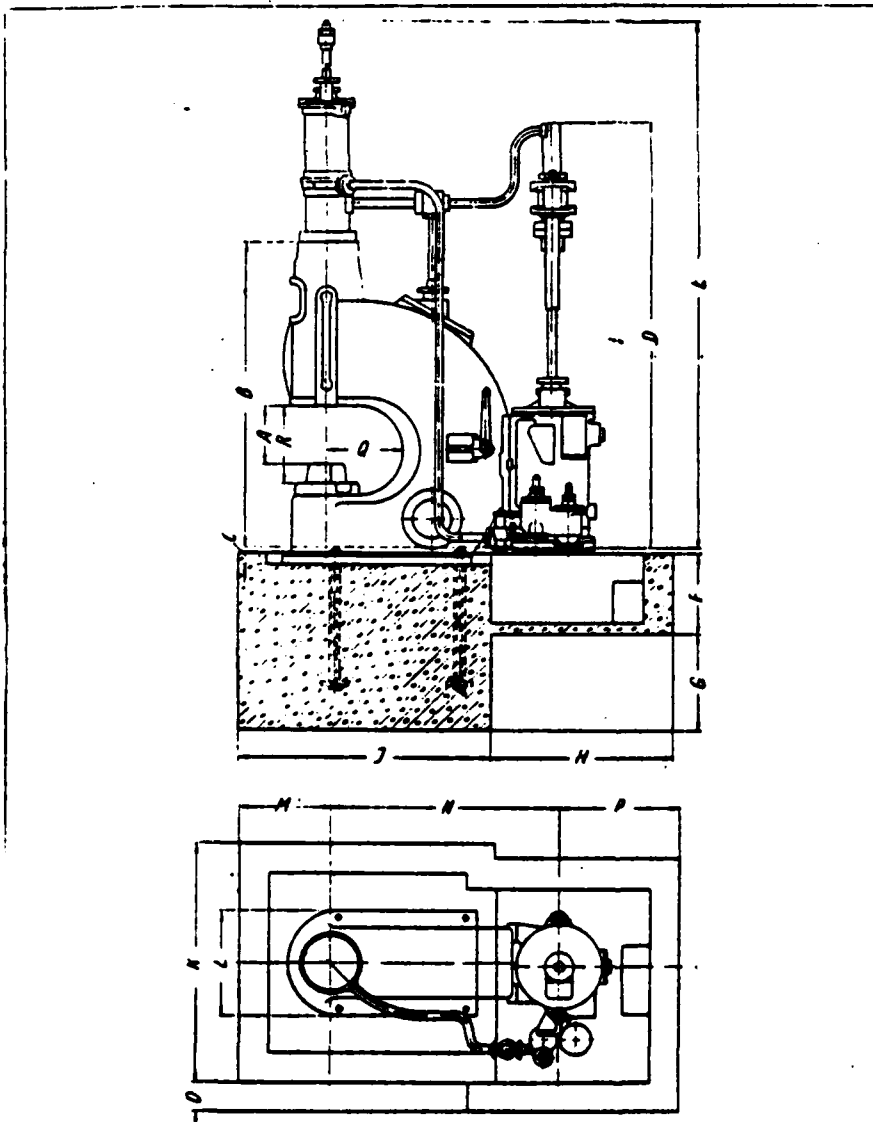

Модель наименование машин	A	B	C	D	E	F	G	H	J	K	L	M	N	O	P	Q	R
	300 500	486 616	2415 3030	190 400	3430 4620	4490 5806	685 686	900 1630	15.5 1660	2076 2896	2065 2440	815 900	710 1015	1830 2380	280 75	980 1170	610 840

Fig. 12. Exemplary/approximate overall dimensions of forging

single-column presses (steam hydraulic).

Key: (1). Nominal effort/force of press in t.

Page 24.

The velocity of the crosshead and rapidity of press, which is determined by a number of courses per unit time during the different cycles of the work of press, are the extremely important parameters of forging presses.

During the drawing operations and finishing of the forging of presses it must work with a large number of courses (finishing of course) low in the value.

The tentative data about the velocities of the work of the presses, which can be used for their selection and planning, are cited in Table 3.

Forging presses in the comparison with other types work in the severe conditions, since, being highest-speed, they are loaded by the eccentric load, which causes nonuniform stress and strain of the basic elements of construction/design.

Eccentric load appears, when deformation is accomplished/realized by an incomplete surface of face, and also during forging of unsymmetric forgings as a result of the noncentral position of ingot on the face. Forces appearing in this case distort the crosshead, they load with the additional bending moments and the forces of column, are created additional specific pressures in the guide bushings of the crosshead and plungers, which leads to their accelerated and nonuniform wear.

The obtained misalignments of the crosshead and plungers connected with it extremely negatively affect the service life of cylinder sealings/packings/compactions.

Table 3. Initial data for calculating the hydraulic forging presses.

(1) Номиналь- ное усилие пресса в т	(2) Длина ра- бочего хода в мм	(3) Длина воз- врат- ного хода в мм	(4) Число рабо- чих ходов в минуту	(5) Скорость ра- бочего хода в мм/сек ¹	(6) Скорость воз- вратного хода в мм/сек	(7) Число ходов при отделке в минуту ²
500	130	160	22	300	400	60-70
800	160	210	18	300	400	60-70
1 250	165	220	14	200	350	60
1 500	180	225	12	200	350	60
2 000	190	270	10	200	350	60
2 500	200	310	10	150	300	60
3 200	200	315	8	150	300	60
4 000	200	320	6-8	125	300	50
5 000	225	340	6	100	300	40
6 000	225	340	6	100	300	35
8 000	250	360	5-6	100	300	30
10 000	275	400	5-6	100	300	25
12 000	275	400	5-6	100	250	20
15 000	300	450	4-5	75	200	15-20

Key: (1). Nominal effort/force of press in t. (2). Length of working stroke in mm. (3). Length of recurrent course in mm. (4). Number of working strokes per minute. (5). Velocity of working stroke in mm/s

¹.

FOOTNOTE ¹. The velocity of working stroke corresponds to the effort/force, developed with press, equal to approximately 0.75 from the nominal. ENDFOOTNOTE.

(6). Speed of recurrent running in mm/s. (7). Number of courses during the finishing per minute ².

FOOTNOTE ². The effort/force, developed with press during the finishing, is accepted by the equal to approximately 0.25 from the

nominal; the value of course is equal to approximately 50 mm.

ENDFOOTNOTE.

Page 25.

For unloading the columns from the moments/torques during the eccentric forging the lever/crank system (Fig. 13), which warns the misalignment of cross-beam during its motion, was applied; however, in view of the unwieldiness it did not receive propagation.

The hydraulic systems applied in the stamping machines (chapter 2), for maintaining the horizontal position of the crosshead during its motion, in the forging high-speed presses also do not apply.

Columns with the large moments/torques effective on them noticeable are bent which causes the oscillation of the crown. In the powerful/thick presses for warning/preventing swaying press and possible breakage in the columns the electrical or optical indicators, which check the side displacements/movements of upper cross-beam and giving distant signal frequently are applied to operator. However, these devices themselves completely did not justify and wide acceptance did not obtain. Abroad for the control of the deformation of columns industrial television is applied.

The eccentric loading of press requires accomplishing its entire construction/design sufficiently rigid with the developed surfaces of the guiding elements/cells.

The system of the direction of the crosshead of press must provide good working conditions of plunger and its sealings/packings/compactions. There are many design concepts of the presses, in which this question is resolved differently. Direction is accomplished/realized either only on the columns (Fig. 14), and in such a case they absorb moment/torque from the eccentric loading of press, or the crosshead has the additional direction in the upper fixed cross-beam, accomplished by a special stem (Fig. 15) or by the plunger, rigidly sealed in the crosshead (Fig. 16).

With the crosshead with the guiding stem the bending moments on the columns prove to be considerably smaller, and therefore this design concept preferably for the forging presses.

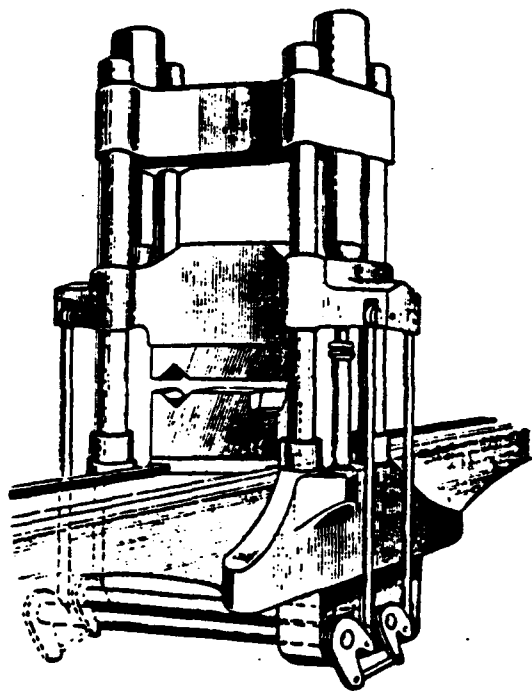

Fig. 13. Schematic diagram of the lever/crank system, which ensures the undistorted motion of the crosshead of forging press.

50

Page 26.

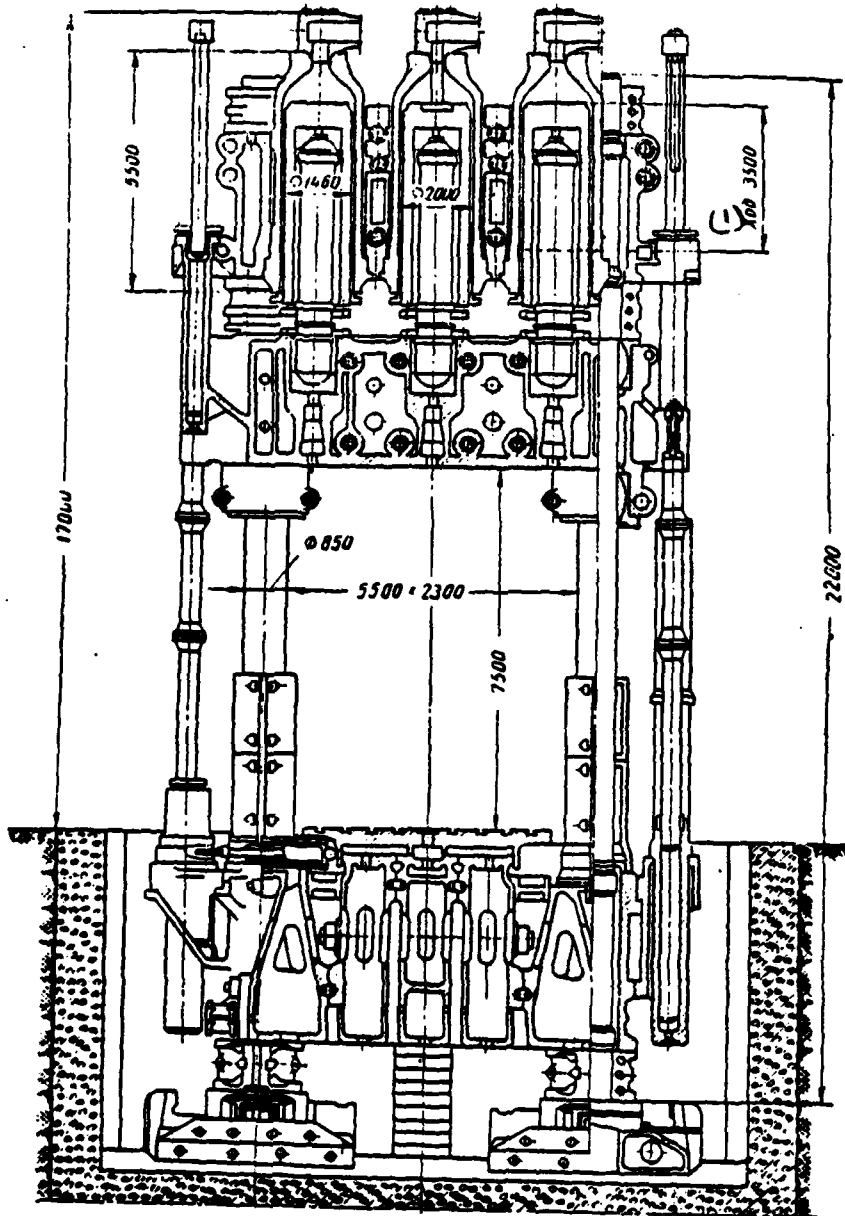

Fig. 14. Hydraulic forging press by effort/force 15000 t.

Key: (1). Course.

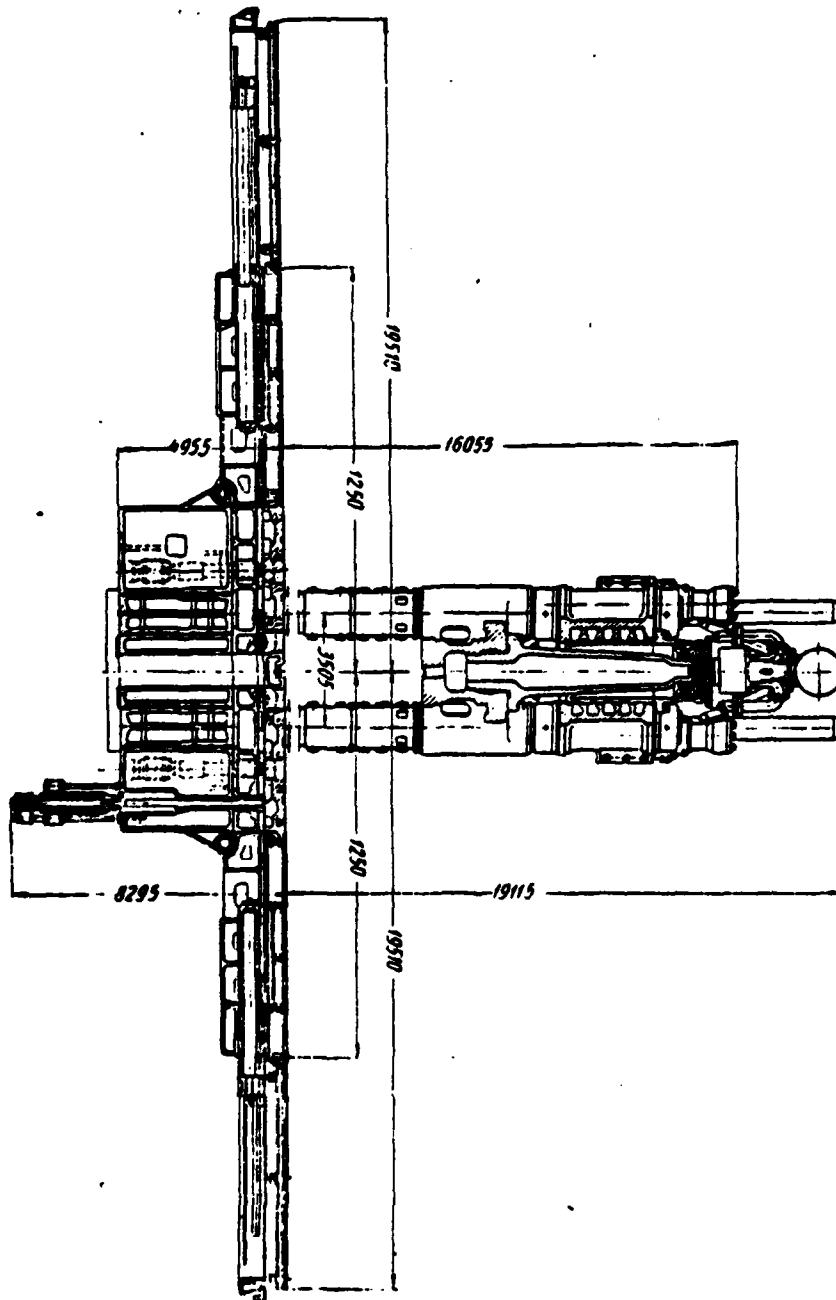

Fig. 15. Hydraulic forging press by effort/force 12000 t (longitudinal section/cut).

Page 28.

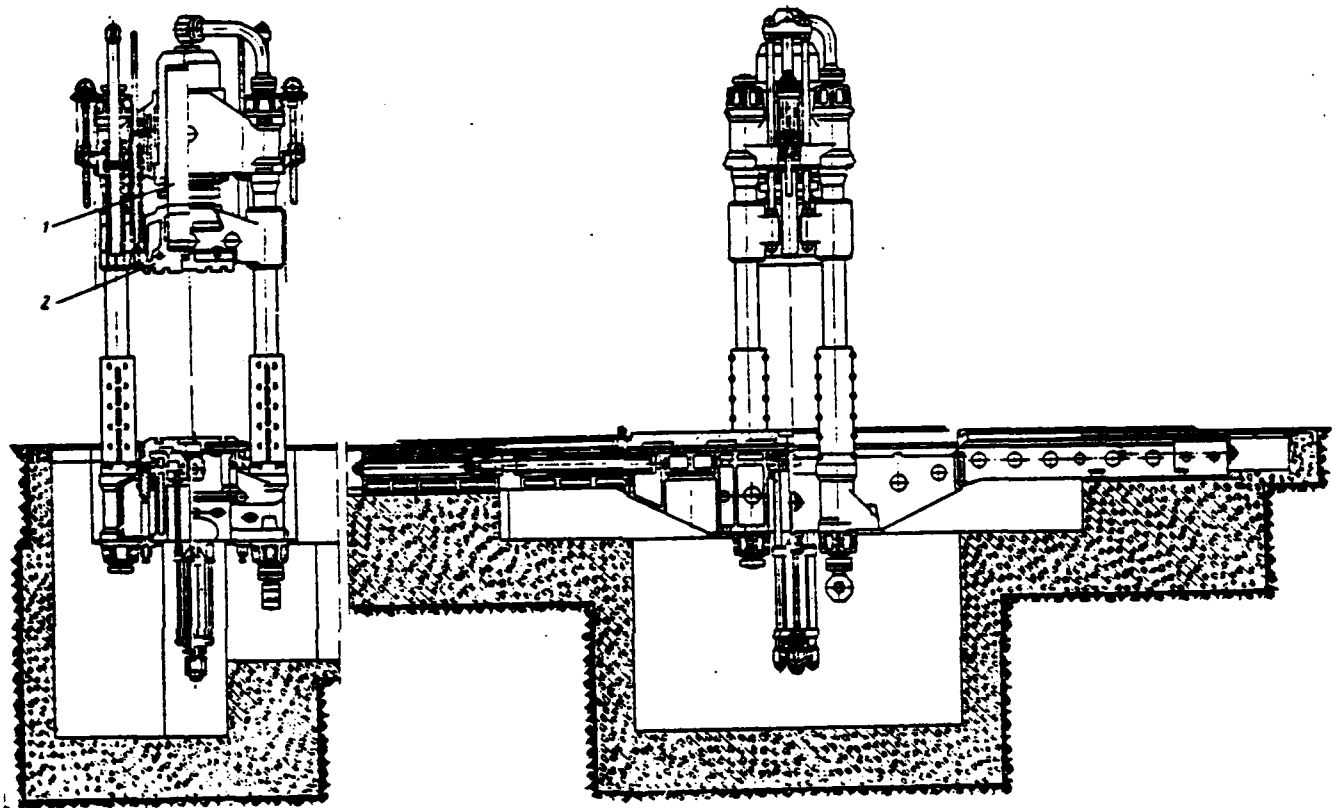

Fig. 16. Hydraulic single-cylinder forging press by effort/force 1500 t: 1 - plunger; 2 - the crosshead.

Page 29.

The realization of the direction of cross-beam by plunger is less successful, since in this case in the cylinder bushings the specific pressures, which call their increased wear, appear, and also

grow/rise stresses/voltages in the walls of cylinder.

During the construction/design of the crosshead with the central guiding stem of presses it is performed by two-cylinder, and, thus, is eliminated the possibility of obtaining several steps/stages of the efforts/forces of press due to the inclusion into the work of a different quantity of cylinders, what is a shortcoming in this performance.

With accomplishing of the guide of stem in the pitch working cylinder with three pressure cylinders, as shown in Fig. 17, pitch cylinder proves to be considerably greater in the diameter, than extreme; because of this the size/dimension of upper cross-beam increases in the narrow side of press. The lubrication of sliding tracks during this performance is extremely difficult.

In the given constructions/designs the stem has the support sliding in the upper cross-beam, through which the cross-beam by load force. There are presses by effort/force 12600 t, designed for the forging with the large eccentricity (to 1800 mm), in which the shank of the crosshead is carried out in the form of the sliding framing (Fig. 18).

This design concept makes it possible to unload columns from the

bending moment, transferred on them by the crosshead, since entire moment/torque from the extra-centric loading of press is transferred by stem to the upper cross-beam. The realization of this condition is possible only in the case of accomplishing of stem and its direction by sufficiently rigid.

For warning/preventing the wear of the guide bushings of plungers and their sealings/packings/compactions the connection of plungers with the crosshead is expedient to accomplish/realize through flange members (pestles) with ball ends. The direct connection of the plungers through ball pivots, frequently performed in the forging presses, is less successful, since large friction in five creates on the plunger the moment/torque, which is received by cylinder bushing, which leads to its rapid wear.

With accomplishing of the crosshead with the stem, which slides in the upper cross-beam, it is expedient guiding shoes it to connect with the cross-beam hinged, as shown in Fig. 17; however this connection structurally/constructionally is difficultly feasible in the presses of low powers.

For the more uniform loading of columns the clearances between the bushings of the crosshead and the columns must be maintained/withstood as far as possible identical; work with the

strongly worn bushings must not be allowed/assumed.

Instead of the generally accepted cylindrical bushings of the crosshead, the not allowing/assuming gap adjustment between the bushings and the columns in the construction/design of press by the effort/force 7000 t, manufactured in England [28] (Fig. 19), are used the guides, who allow/assume gap adjustment via the tightening of wedges. However, in view of the complexity of manufacture this construction/design did not receive propagation.

62

Page 30.

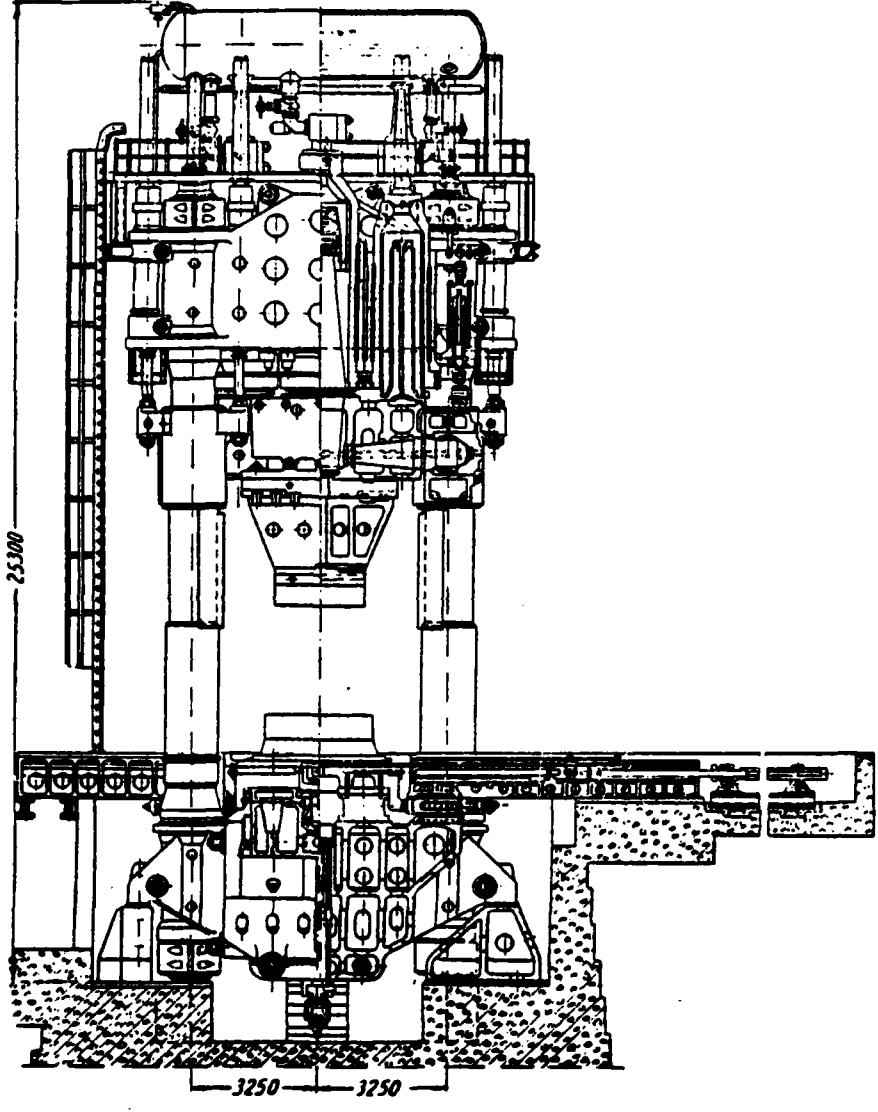

Fig. 17. Hydraulic forging press by effort/force 15000 t.

Page 31.

The rigidity of the basic frame of press to a considerable degree depends on the joint design of columns with the upper and lower fixed cross-beams. This connection is accomplished/realized either by nuts (on four nuts to each column), or by collars, instead of the internal nuts, by external nuts (Fig. 20). The collars of columns are performed to the conical descent of identical form with the appropriate borings in the cross-beams.

Connection by nuts is more convenient for the installation of press. During the construction/design of columns with the collars the frame of press after assembly possesses high rigidity; the ends of the columns work in the conditions, close to the rigid framing; the threads of nuts and columns prove to be in this case under the best conditions; it is not observed the wear of the surfaces of nuts and bearing surfaces under the nuts on the cross-pieces, and therefore connection on the collars should be given preference.

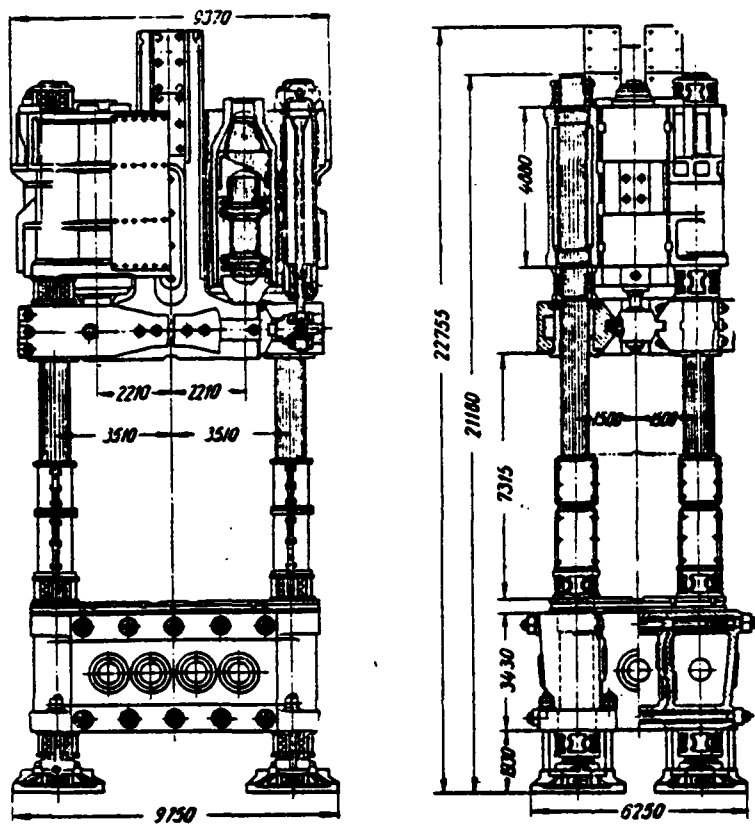

Fig. 18. Hydraulic forging press by effort/force 12600 t.

Page 32.

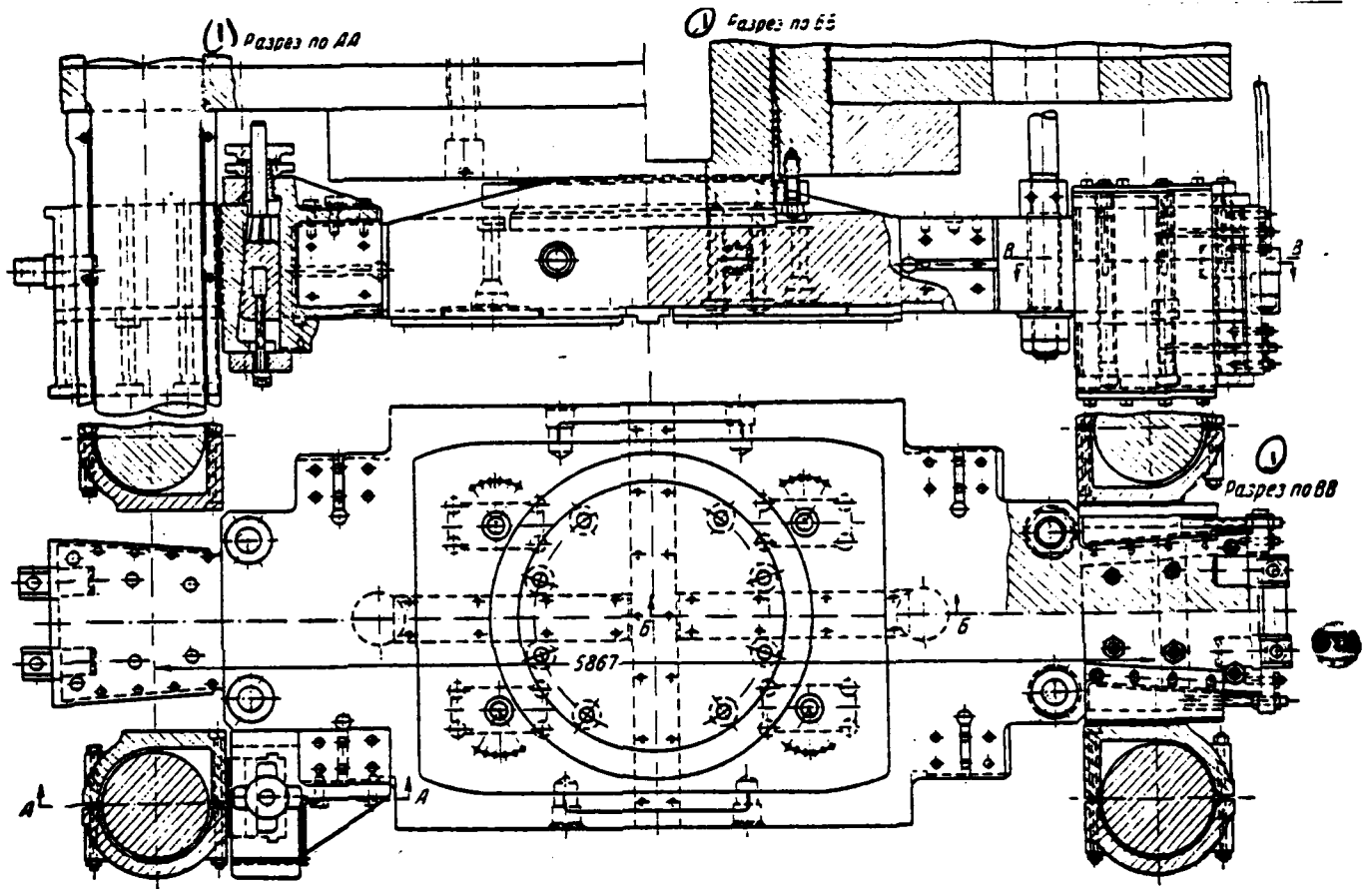

Fig. 19. The crosshead of forging press by effort/force 7000 t.

Key: (1). Section/cut.

Page 33.

The aforesaid about the requirements for the construction of

forging presses to the equal degree relates also to the presses of another designation/purpose, that work with the eccentric loading.

The lower base/root of forging press is performed from several parts. The rigid and strong joint of the parts of the base/root is the necessary condition for guaranteeing the service life of the entire construction/design of press.

The construction/design of lower base/root, in which separate castings are connected with general/common/total plate/slab, as shown in Fig. 21, should be recognized most successful for the forging presses. However, this performance virtually can be realized for the presses with the efforts/forces to 6000 t.

For the rapid replacement of faces in the press, besides the table, moving along the narrow side of press, sometimes additionally build in side cylinder and the plates/slabs, on which it would be possible to move the faces (see Fig. 17), but in this case the side flight/span between the columns is enclosed, what is undesirable.

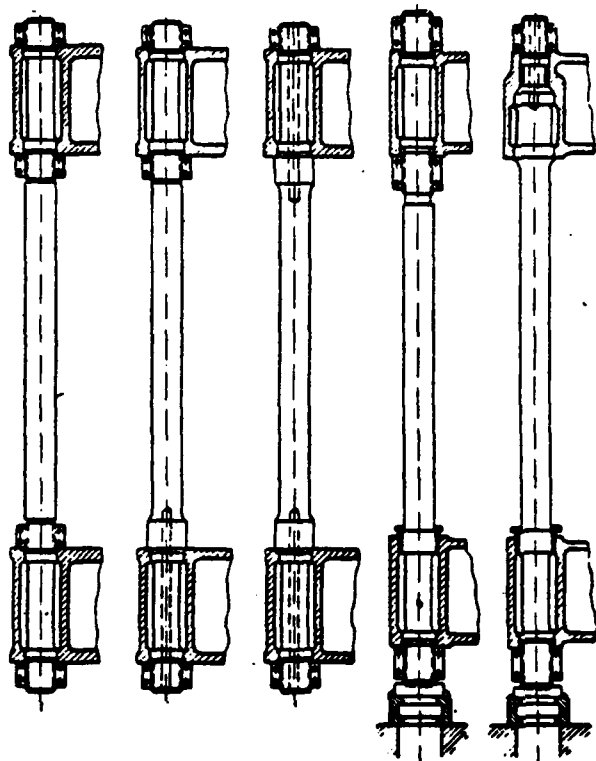

Fig. 20. Forms of the connection of columns with the immobile cross-beams, used in the forging presses.

Page 34.

The most widely used until recently drive of forging presses it was steam hydraulic, which ensures high rapidity high rapidity, necessary during the forging. However, as a result of its uneconomical nature, it is extruded by the pump-and-battery and electro-multiplier drives. Non-accumulator/battery pumping drive

obtained wide acceptance for stamping and many other machines for the forging presses is applied relatively rarely, as a result of the need for having powerful/thick pumping stations and the imperfection of the constructions/designs of contemporary powerful/thick high-pressure pumps.

At the plant of English steel company are established/installed six presses with the efforts/forces 1430-7000 t, which have the direct drive from three-plunger pumps. The characteristics of these pumps are given in Table 4 [28].

The most powerful/thickest pump, which operates press by effort/force 7000 t, is given from the asynchronous electric motor with the slip rings with a power of 2500 hp. In spite of large lifting power, these presses work with the lowered/reduced velocities of working stroke (50 mm/s). Shortcoming is also the absence of the possibility of regulation of the velocity of the motion of the crosshead during the working stroke, and also the impossibility of the clamp of the ingot between the faces.

The work of these presses with different velocities can be accomplished/realized with the aid of the throttle valves, connected with the hydraulic system, moreover upon the start of the valve of presses develops considerably smaller against the nominal effort/force.

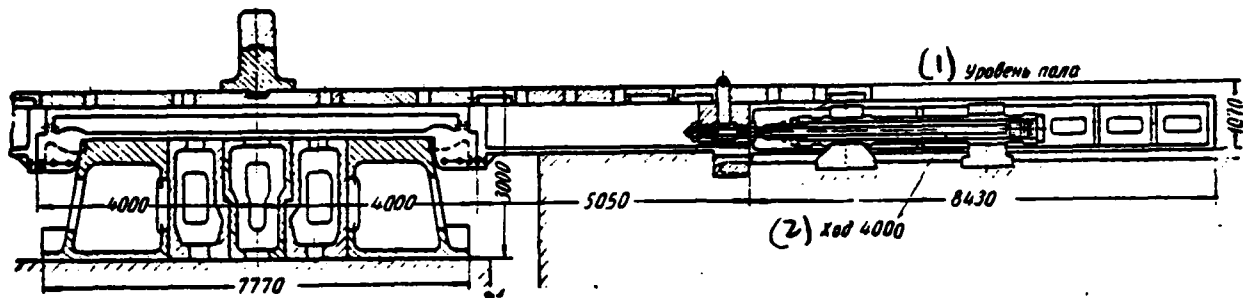

Fig. 21. Base/root of forging press by effort/force 6000 t.

Key: (1). Floor level. (2). Course.

Page 35.

With the control of the velocity of press due to jettisoning of the part of the supplied liquid through the valve to a certain extent the major advantage of pumping batteryless drive diminishes, since the part of the energy, developed with engine, is expended/consumed unproductive on the creation of the fluid flow, which proceeds with jettisoning. Considerably best performance properties could be obtained during the drive along the system electric motor - generator. However, the realization of this installation/setting up is connected with the high expenditures.

There are scarce cases of use/application for the drive of the

DOC = 83120702

PAGE

70

forging presses of rotational-plunger pumps, which work on mineral oil. Fig. 22 depicts forging press as effort/force 1000 t with such pumps.

Table 4. Pump performance of the independent drive of presses without the storage battery/accumulator.

(1) Усилия пресса в т	(2) Скорость рабочего хода в мм/сек	(3) Подача насоса в л/мин	(4) Давление в кг/см ²	(5) Число оборо- тов насоса в минуту	(6) Мощность электродвига- теля в кВт	(7) Максималь- ная мощность при 15% скольжении маховика в кВт
7000	50	4983	348	84	1840	4750
4000	50	1336	418	100	665	1470
2250	50	1336	348	100	665	1470
1430	50	765	348	110	440	680

Key: (1). Force of press in t. (2). Velocity of working stroke in mm/s. (3). Supply of pump in l/min. (4). Pressure in kg/cm². (5). Number of revolutions of pump per minute. (6). Power of electric motor in kW. (7). Maximum power with 15% slip of flywheel in kW.

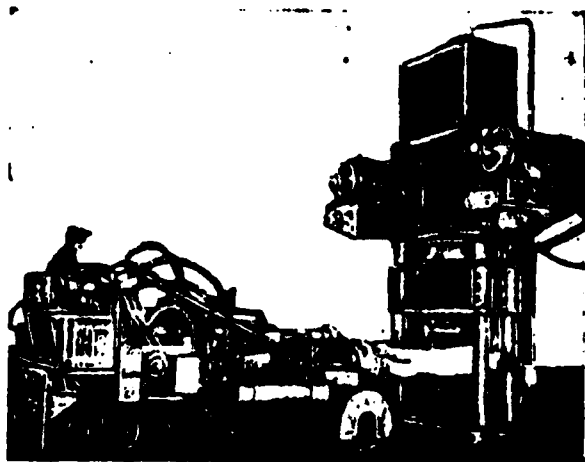

Fig. 22. Forging press by effort/force 1000 t with the drive from rotational-plunger pumps.

Page 36.

Press is given from two assembled on its upper cross-beam pumps with a productivity of 430 l/min each at a pressure 175 kg/cm². Pumps are given from the electric motors with a power of 140 hp each at hydraulic lifting power, equal to 200 hp, and, thus, designed for the work with the overloading. The operating speed of the course of the crosshead of this press, in spite of great power of pumps, is only 23 mm/s.

The given examples show that a question about the use/application of individual pumping batteryless drive for the forging presses yet does not have positive answer.

It indicates ~~the~~ practice of the operation of forging presses with the pump-and-battery drive the possibility of the construction of powerful/thick and sufficiently high-speed presses during their more economical operation with this drive in comparison with the the steam hydraulic. There are examples of the creation of presses with efforts/forces 6000; 12000 t (Czechoslovakia) and with the efforts/forces to 12600 t (USA) with the pump-and-battery drive, which corresponds to the requirements, imposed on the forging presses.

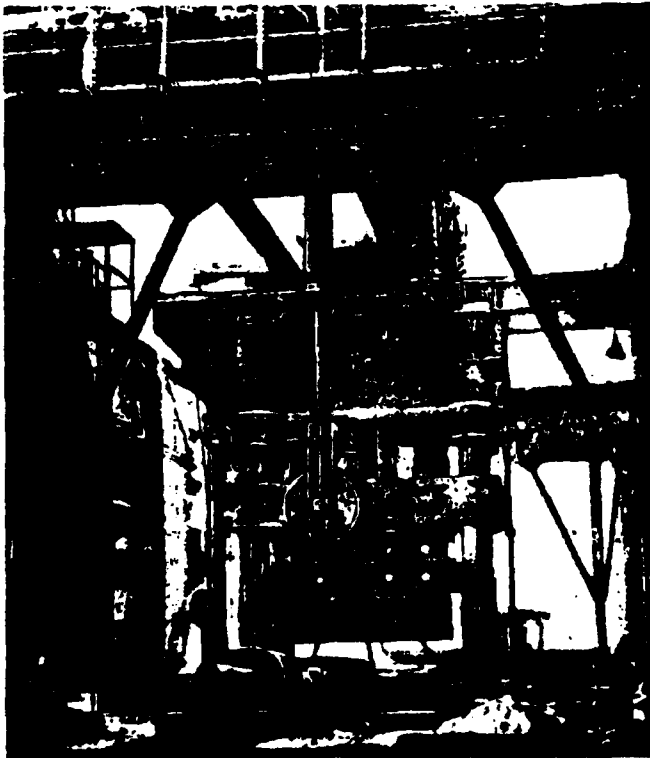

Fig. 23. Forging crankshaft on the press by effort/force 12600 t.

Page 37.

Press by effort/force 12600 t (Fig. 23) has parameters of the drive:

Pressure of liquid in kg/cm^2 ... 310.

Number of pumps in pcs ... 4.

Supply of each pump in l/min ... 1500.

Total storage capacity of storage battery/accumulator in l ...
56000.

Velocity of the crosshead in mm/s:

with the idle and return courses ... by 300.

with the working stroke ... by 75.

Study for two years of the performing characteristics of this press and analogous press according to the characteristic and by the construction/design, but with steam hydraulic power gear, came to light/detected/exposed the considerable advantages of the pump-and-battery drive (Table 5).

For guaranteeing high rapidity of press during the pump-and-battery drive it is necessary to have the powerful/thick pull-backs, which develop effort/force to 10% of the nominal effort/force of press, individual pump-and-battery station, as far as possible it is nearer that arranged/located to the press (Fig. 24 and 25), the sufficiently strong and well attached conduit/manifold and the low speeds of flow of liquid in it.

Table 5. Comparative data of work of forging presses by effort/force 12600 t with the the steam hydraulic and with purely hydraulic (pump-and-battery) drive [29].

(1) Наименование показателей	(2) Паро-гидравлический пресс	(3) Чисто гидравлический пресс
	(4) Период эксплуатации	
	(5) Более 2 лет с 2- и 3-сменной работой	(6) Более 2 лет с работой по 5 и 8 час. в смену
(7) Средний расход энергии	(8) 14 850 кг пара час	(9) 625 кВт час
(10) Пиковая мощность	99 000 кг пара ⁽¹¹⁾	3750 кВт ⁽¹²⁾
(13) Производительность пресса	66 т поковок ⁽¹⁴⁾ час	75 т поковок ⁽¹⁴⁾ час
(15) Производительность пресса при отделке поковок	11,2 т/час ⁽¹⁴⁾	13,3 т/час ⁽¹⁴⁾
(17) Относительная стоимость расходуемой энергии за один час работы пресса	100%	30,5%
(18) Относительная стоимость оборудования и материалов, расходуемых на ремонт, отнесенная к одному часу работы пресса	100%	465%
(19) Относительная стоимость рабочей силы, привлекаемой для наблюдения за работой и ремонтом пресса, отнесенная к одному часу работы	100%	102%
(20) Относительная стоимость эксплуатации, отнесенная к одному часу работы пресса	100%	72%

Key: (1). Designation of indices. (2). Steam-hydraulic press. (3). Purely hydraulic press. (4). Period of operation. (5). More than 2 years with 2nd and 3rd interchangeable work. (6). More than 2 years with the work on 5 and 8 hours in the replacement. (7). Average/mean energy consumption. (8). kg steam/h. (9). kW/h. (10). Peak power. (11). kg steam. (12). kW. (13). Productivity of press. (14). forgings/h. (15). Productivity of press during finishing of forgings. (16). t/h. (17). Relative cost/value of the expendable energy in one

hour of the work of press. (18). Relative cost/value of equipment and materials, expended to the repair, referred one hour of the work of press. (19). Relative cost/value of the work force, drawn for the observation of work and repair of press, referred one hour of work. (20). Relative cost/value of operation, in reference one hour of the work of press.

Page 38.

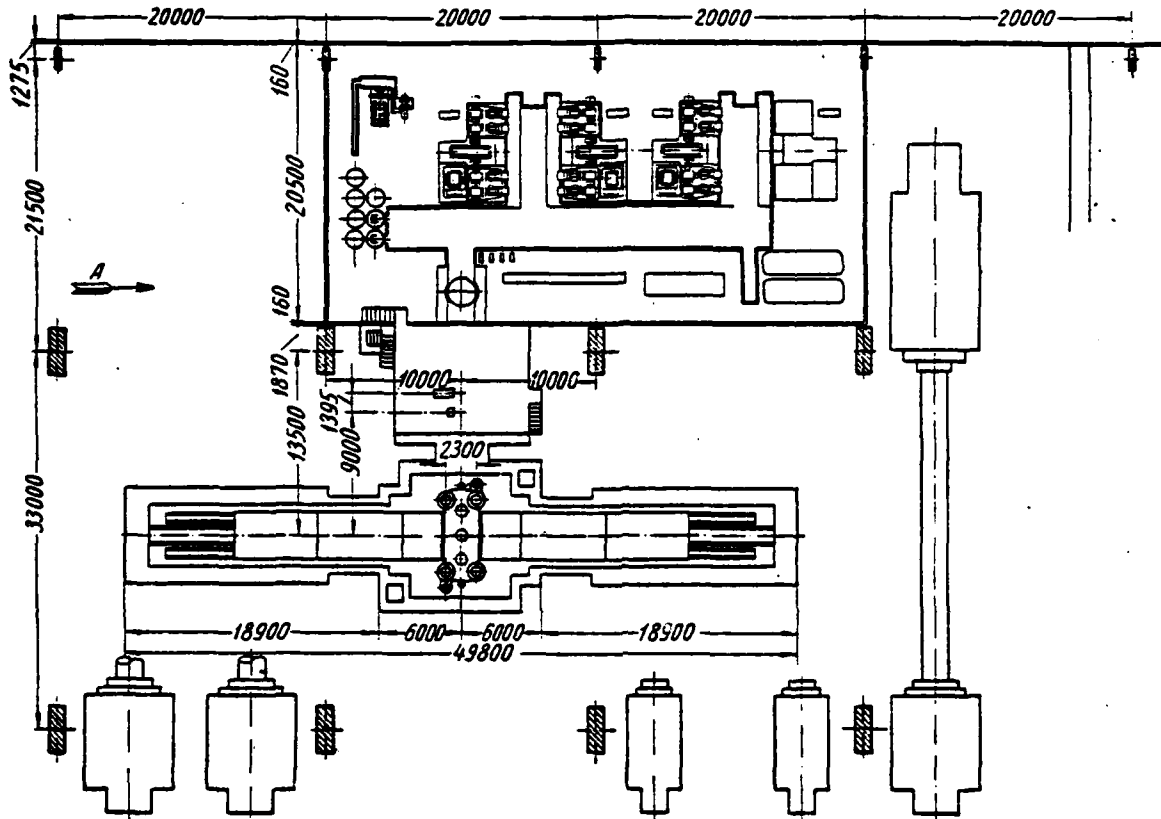

Fig. 24a. Planning of the equipment of forging press by effort/force 6000 t and its operating pump-and-battery station (Czechoslovakia).

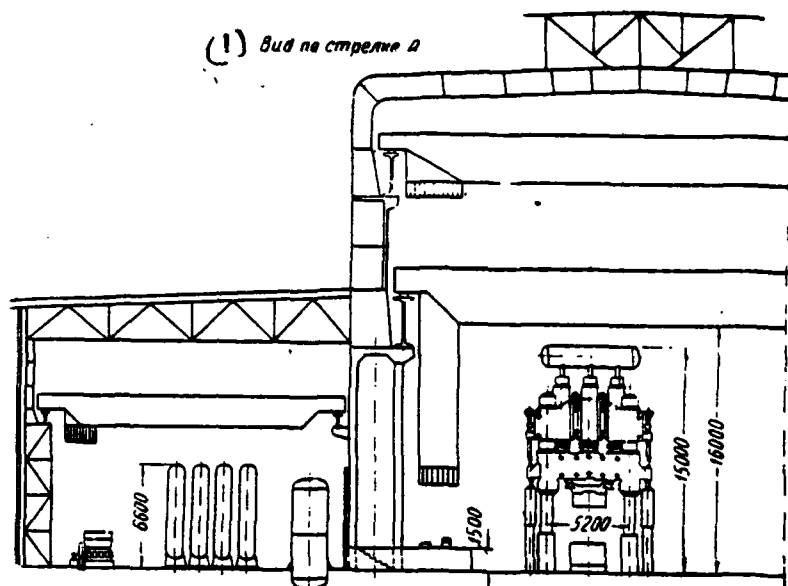

Fig. 24b. Planning of the equipment of forging press by effort/force 6000 t and its operating pump-and-battery station (Czechoslovakia).

Key: (1). Form on arrow/pointer A.

Page 39.

Control of press must be designed so that the operator would spend the minimum of energy. Valve opening must be accomplished/realized with the aid of the auxiliary hydraulic systems.

For the forging presses, which work with the frequent, but short

courses, the use/application of a multiplier, which raises the pressure of the liquid, which enters the press from the pump-and-battery station, is justified. The maximum effort/force of press is utilized only during forging of ingots maximum by the weight and with the precipitation operations. With the exhaust operations it is required approximately by $1/2-2/3$, while with the finishing operations - not more than $1/3$ nominal efforts/forces of press, and therefore the use/application of a multiplier reduces fluid flow rate, consumed by press.

In comparison with the drive from the pump-and-battery station, drive from electromechanical multiplier [27] is more economical and ensure high rapidity of press.

Page 40.

However, the large dimensions of multipliers and requiring for the heavy-duty drive limit their use. The values of supply to liquid for one course in electromechanical multipliers in the constructed presses are selected approximately equal to the supplies of the steam-air multipliers.

Since during the use/application of a multiplier usually the recurrent course is accomplished/realized from the pump-and-battery station, it is expedient power it to select from the calculation of the feeding of press during the completion by the latter sediments/residues and reduction of ingot, but for the exhaust operations, which do not require large courses, and for finishing the forgings to apply high-speed multipliers.

In contemporary press rooms the means of mechanization are the decisive factor in the use of equipment, increase in productivity, reduction in labor consumption and cost/value of the manufacture of forgings and improvement in the quality of their finishing.

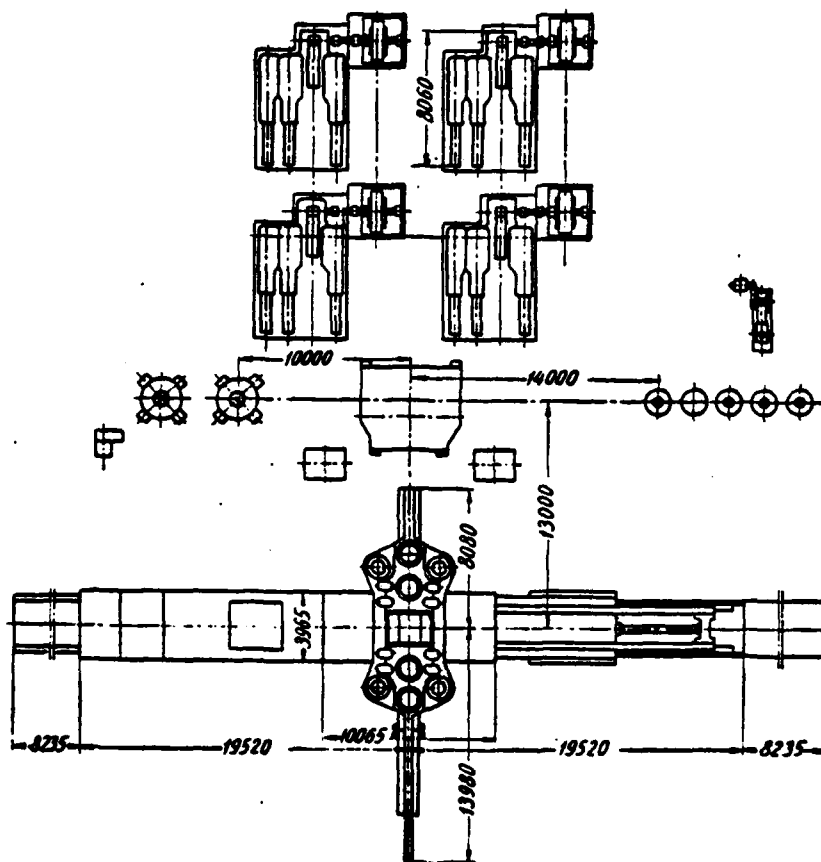

Fig. 25. Planning of the equipment of forging press by effort/force 12600 t and its servicing pump-and-battery station (firm United, USA).

Page 41.

The means of mechanization to a considerable degree determine also the working conditions of working forging aggregates/units.

For the transportation of ingots and manipulation with them under the press the latter must be serviced to two bridge cranes of the corresponding load capacity, by the equipped suspension tilters.

Crane load must be determined by the maximum weight of the ingot, which can be forged on the press, taking into account the weight of tilter. For the best manipulation with short ones, but the large diameter by ingots it is necessary that the taps/cranes nearest possible would match up the press, and therefore their constructions/designs differ from the constructions/designs of common bridge cranes. Forging tap/crane must have the reliable protecting devices, which warn the shock loading of its bridge/axle and mechanisms.

The possibility of the close approach of taps/cranes to the press is achieved by the special construction/design of crane trucks. Frequently for best servicing of the press, for the possibility of the closer approach to it of taps/cranes, are applied the taps/cranes, adjusted on the different levels (Fig. 26), or three taps/cranes, of which one smaller load capacity walks on the ways, arranged/located higher than two basic taps/cranes.

For the powerful/thick presses the taps/cranes with two trucks of different load capacity are applied also.

For turning of ingots under the press, used are chain/catenary tilters with the spring suspension with Gall's circuits, manufactured from high-temperature (strength) steel. The rotation of the endless chain is accomplished/realized by the electric motor, assembled in the group of tilter. One of the constructions/designs of tilter is shown in Fig. 27.

For the manipulation with the instrument (axes, unrollings, etc.) during the forging the presses are frequently equipped with hydraulic rope hoists, one of constructions/designs of which is shown in Fig. 28. For these purposes special outdoor/floor machines are applied also. The trunk of these machines, the carrying instrument, are cranked up into the press on the narrow flight/span of columns.

For the shops with the hydraulic presses by efforts/forces to 6000 † and the hammers with a weight of the falling/incident parts of up to 5 t the most general-purpose means for the best use of equipment and facilitation of the labor/work of worker are outdoor/floor forging manipulators. These machines appeared in the period of the First World War and at the present time it is considerably improved and are constructed by load capacity to 100 t. Are created many constructions/designs of manipulators for their use

in shops different in the character of production and with different planning of equipment in the shop. Manipulators are constructed for the motion along the rails, laid in press (rail), and on the wheels with the rubber tires - trackless (Fig. 29).

Rail outdoor/floor manipulators are constructed large load capacity and was received wide acceptance, since in the forge-press shops difficult to support hem in a good state, which requires for the trackless manipulators, and, moreover, the lifting capacity of the latter is limited to 15 t.

Page 42.

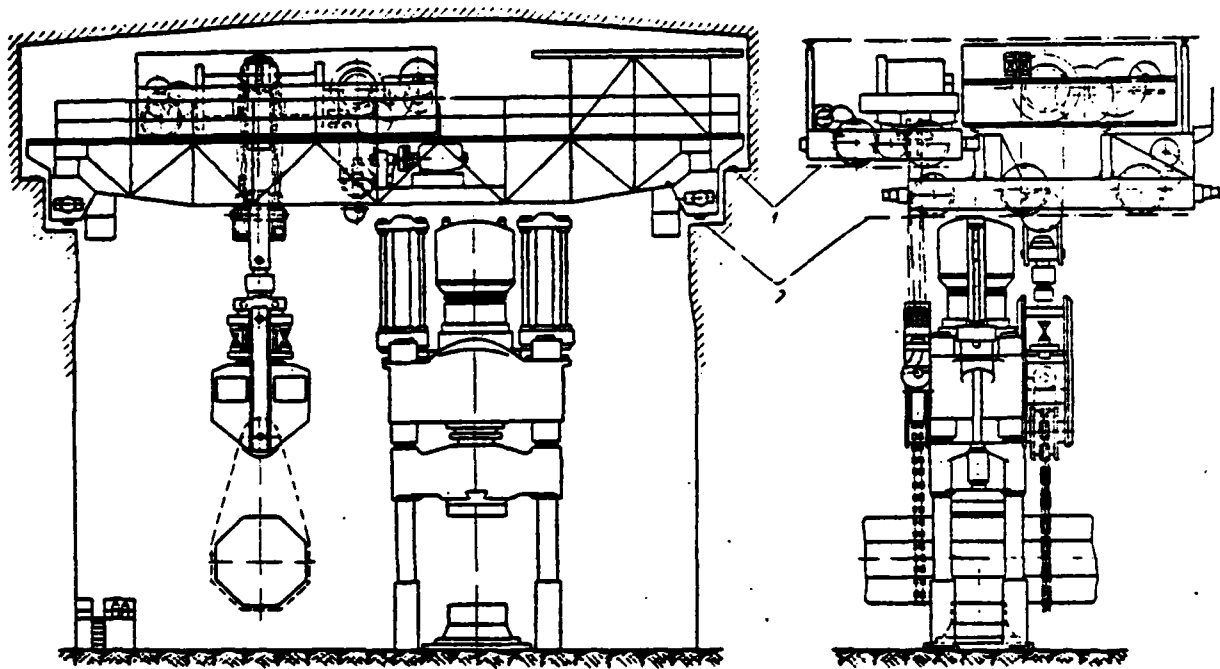
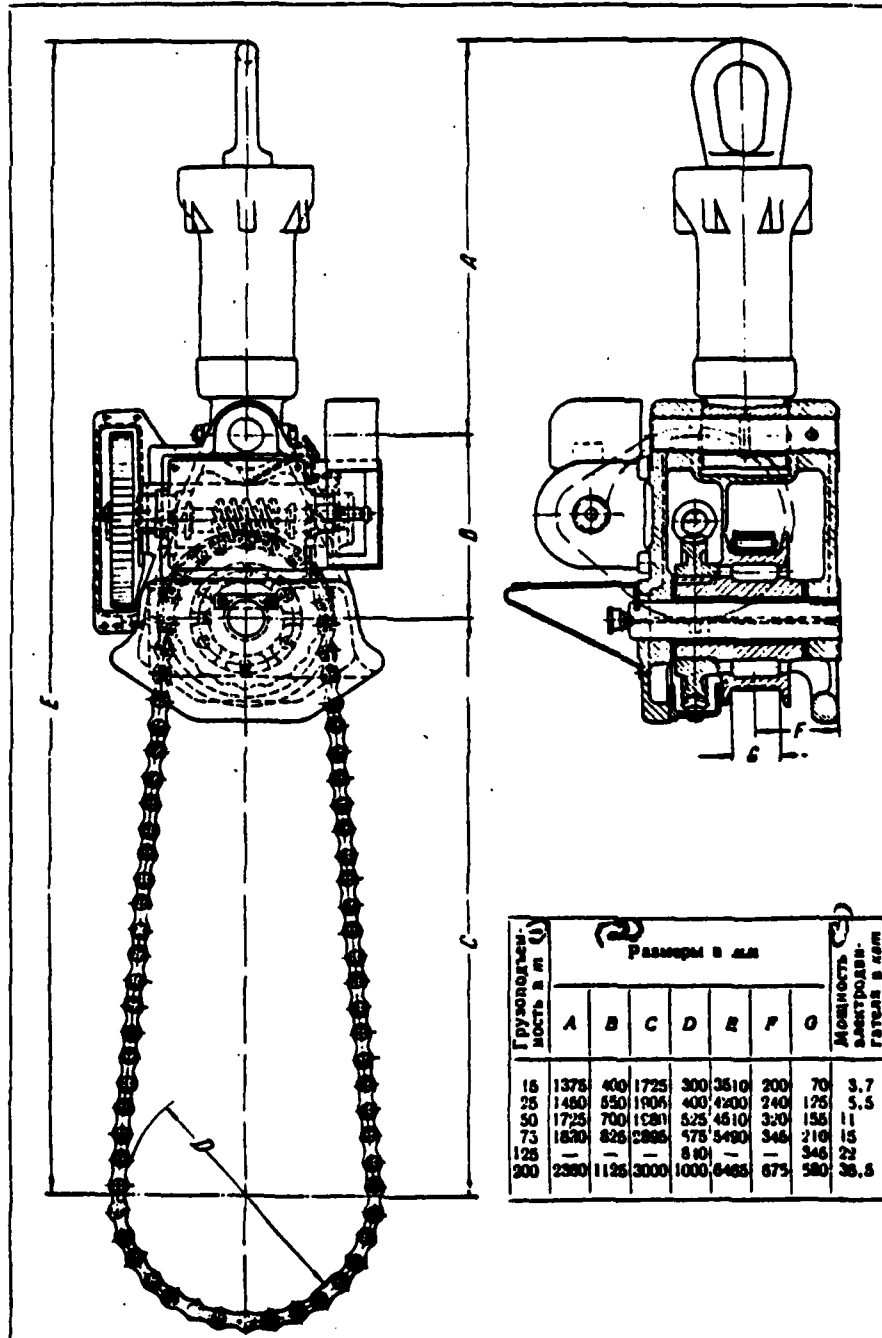

Fig. 26. The installation/setting up of taps/cranes in forging press by effort/force 3000 t: 1 - upper way of the auxiliary tap/crane of smaller load capacity; 2 - lower way of basic tap/crane.

Page 43.



Грузоподъемность в м (t)	Размеры в мм							Мощность электродвигателя в кВт
	A	B	C	D	E	F	G	
16	1375	400	1725	300	3510	200	70	3.7
25	1450	550	1905	400	4200	240	125	5.5
35	1725	700	1920	525	4510	320	155	11
50	1870	825	2065	575	5490	345	210	15
75	—	—	—	800	—	—	345	22
100	2390	1125	3000	1000	6465	675	580	36.5

Fig. 27. Exemplary/approximate construction/design and the overall dimensions of suspension tilters.

Key: (1). Load capacity m. (2). Sizes/dimensions in mm. (3). Power of electric motor in kW.

Page 44.

The construction/design of contemporary rail manipulator is shown in Fig. 30.

In the practice of the use of forging manipulators in the forge-press shops were marked two directions: the use of a manipulator only for the work on press and simultaneously its use, together with accomplishing of main functions, also for accomplishing the transport operations (for supplying the blanks into the press, removal/distance of forgings from the press, while in a number of cases and for the load of furnaces and taking of the heated blanks from the hearth of furnace and their supply to the press).

In the first case of the manipulator the displacements/movements of trunk in the horizontal plane is not required, and therefore its construction/design proves to be more stable.

For the servicing of furnaces and accomplishing of all transport operations the taps/cranes or special machines are necessary.

In the presses, intended for forging of long forgings, frequently it is set to two manipulators. Work with two manipulators is most rational, it gives the best use of the press.

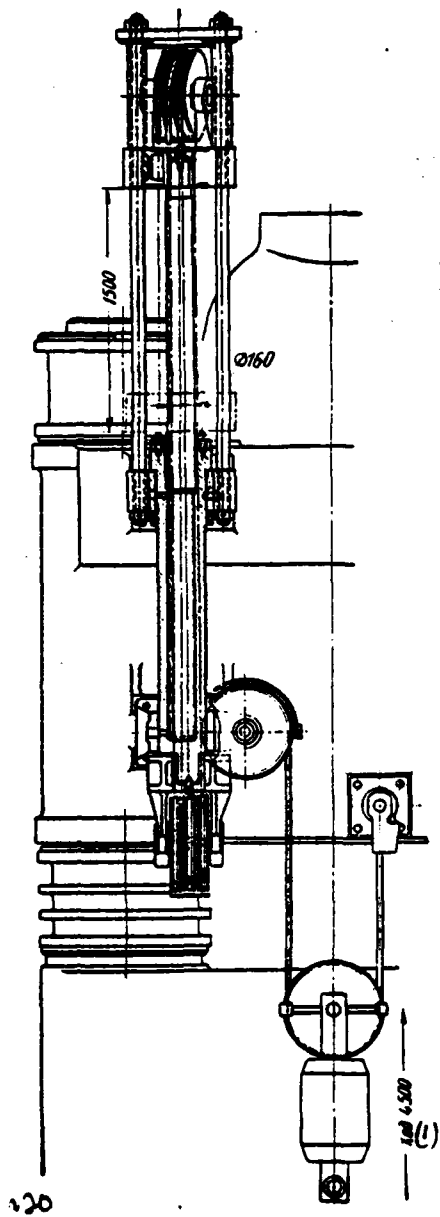

Fig. 28. Exemplary/approximate construction/design of the hoist, installed on the forging press.

Key: (1). course.

Page 45.

The use/application of forging outdoor/floor manipulators in the forge-press shops gives large technical and economic effect, is raised the use of forging equipment and its productivity, a number of workers in the crew, which operates forging aggregate/unit, is decreased. Crew is comprised of the less skilled workers. The fineness of forgings is improved. Fuel/propellant is saved, since the process of forging continues more rapidly, presses it works with a large number of courses per unit time and therefore is decreased a number of heatings of blank. The working conditions of workers, which operate forging aggregate/unit, are improved, their enervation descends. The prime cost of forgings is decreased.

The productivity of presses during the forging with the manipulators can sharply oscillate; however for the approximate estimate of the technical and economic effect, obtained that use/application of a manipulator, it is possible to consider that the productivity of forging aggregate/unit is doubled, and a number of operating workers is decreased doubly, and, thus, issue by one worker increases 4 times. The exemplary/approximate relationships/ratios of the efforts/forces, developed with press, and the load capacities of manipulators are given in Table 6.

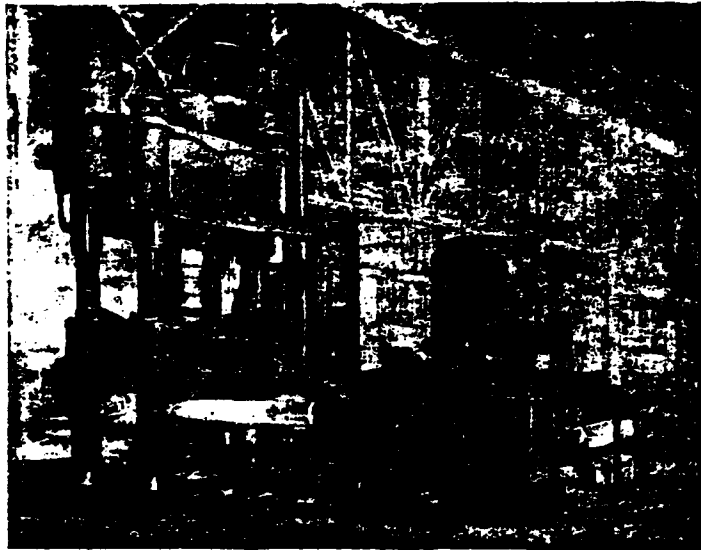

Fig. 29.. Forging on the press the use of outdoor/floor trackless manipulator by load capacity 2.2 t.

Table 6. Relationship/ratio of the efforts/forces of forging presses and load capacities of manipulators.

(1) Усилие пресса в т	500	800	1000	1500	2000	2500	3000	4000	5000	6000
(2) Грузоподъем- ность манипуля- тора в т	3	5—10	10	15	20	30	30	50	50—60	60

Key: (1). Effort/force of press in t. (2). Load capacity of manipulator in t.

AD-A139 822

HYDRAULIC PRESSES(U) FOREIGN TECHNOLOGY DIV
WRIGHT-PATTERSON AFB OH B V ROZANOV 09 MAR 84
FTD-ID(R5)T-1207-83

2/10

UNCLASSIFIED

F/G 13/9

NL

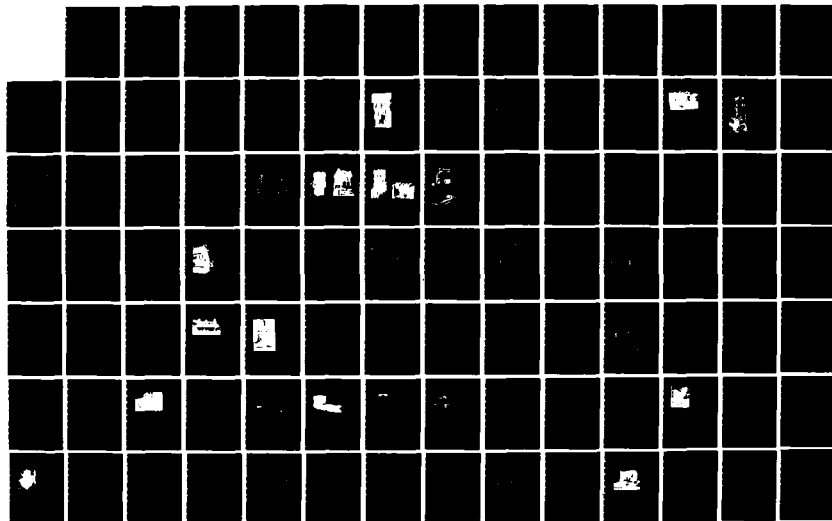

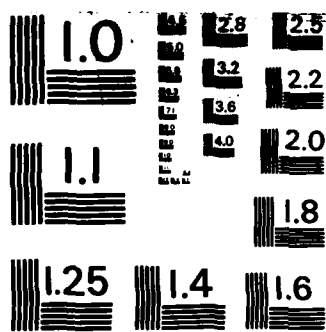

MICROCOPY RESOLUTION TEST CHART
NATIONAL BUREAU OF STANDARDS-1963-A

Page 46.

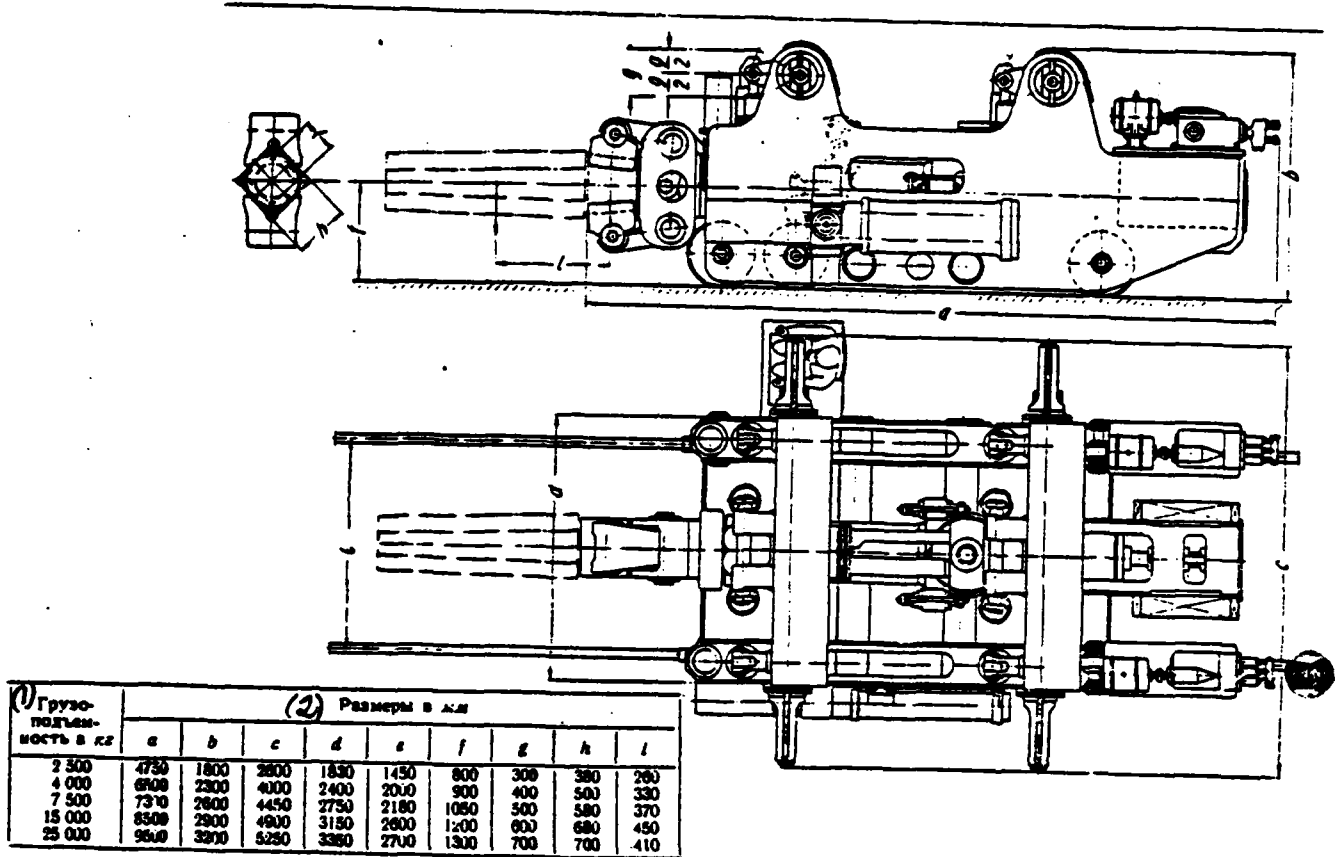

Fig. 30. Construction/design and the basic dimensions of manipulators with hydraulic drives of the mechanisms of trunk.

Key: (1). Load capacity in kg. (2). Sizes/dimensions in mm.

Page 47.

Stamping Presses.

Stamping parts in the closed dies on the hydraulic presses obtained use/application mainly in those branches of machine building, where for manufacturing the overall parts are applied the light metals: aluminum, magnesium and their alloys, which have the relatively low temperature of forging ($t=450^{\circ}\text{C}$).

From the steel parts of mass production by stamping on the hydropresses are obtained the wheels of railroad cars, steam locomotives and diesel locomotives.

Presses for stamping of parts from light alloys.

In the thirties of present century aluminum and magnesium alloys began to apply for manufacturing the overall parts of many machines and constructions. Casting was primary technology of the manufacture of such parts. However, castings had relatively low fatigue limit and were manufactured with the large machining allowances, since the obtaining of castings with thin edges/fins and crosspieces is difficult.

The requirement of a reduction/descent in the weight of parts and labor consumption for their manufacture led to the

use/application of stamping.

The constructions/designs of contemporary presses make it possible to obtain the sufficiently high productivity during the stamping, which consists of 400-450 pcs for the eight-hour replacement of large-size complicated ones in form of parts, to 700 pcs it is more - during the stamping relative to simple parts.

Examples of the constructions/designs of the forgings, stamped on the presses in the hot state, they are shown in Fig. 31. With the hot die forging on the presses of parts from the aluminum alloys the average specific pressures are 15-50 kgf/mm² and more, changing in the dependence on the material of part, its form and mainly from the thickness of crosspieces, walls and edges/fins of part. High specific pressures during the stamping, and also large dimensions of parts caused the need for the construction of the stamping machines, which develop the large efforts/forces, which considerably exceed those, with which presses of other types, for example, forging, blanking, etc are constructed.

The characteristics of the constructed stamping presses are given in Table 7.

To the construction/design of stamping machine high requirements

in the part of obtaining stampings with precise sizes/dimensions, which make it possible to reduce to a minimum their subsequent machining, are presented. For obtaining the precision stampings of press must be performed with the sufficiently rigid ones, that give low saggings/deflections, by table and by the crosshead. For obtaining the low saggings/deflections of table and crosshead and their minimum dimensions and weights is necessary the rational construction of the schematic of the power loading of press, i.e., the selection of a quantity of working cylinders and their arrangement/position, and also quantity and the arrangement/position of the supports of bolster. A quantity of working cylinders of powerful/thick press must be minimum and placed they must be as far as possible nearer to the center of press.

Pages 48-49.

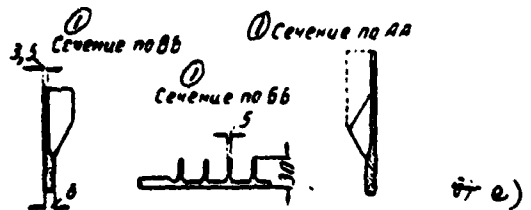
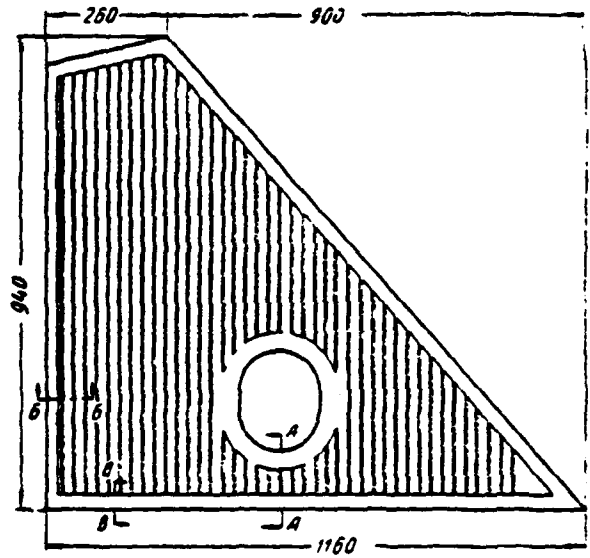
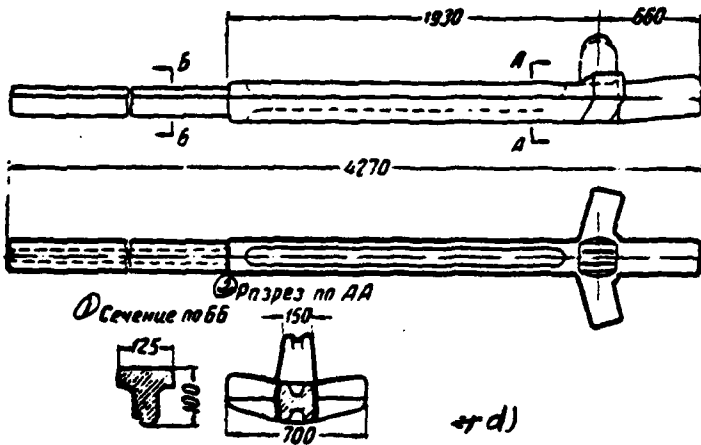
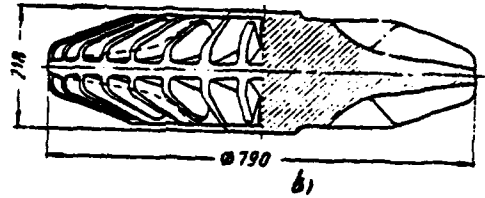
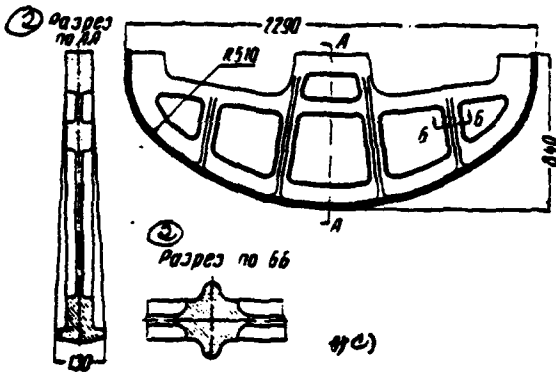
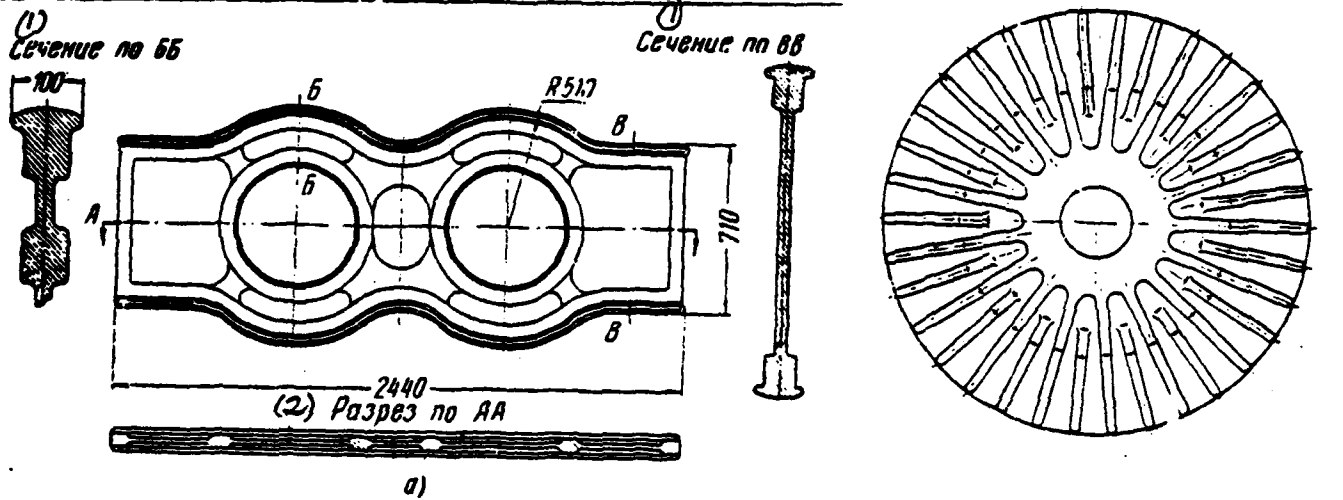

Fig. 31. Examples of the constructions/designs of the forgings, stamped on the hydraulic presses: a) the part of engine mount; b) disk; c) frame; d) beam/gully; e) panel.

Key: (1). Section/cut throughout. (2). Section/cut on.

Pages 50-51.

Table 7. Characteristic of stamping presses.

(1) Наименование параметра	(2) Фиг. 33	-	-	(3) Фиг. 34	(4) Фиг. 35	(5) Фиг. 36	(6) Фиг. 37
(7) Максимальное усилие, развиваемое прессом, в т	2 000	3 000	5 000	5 000	7 200	10 000	10 800
(8) Число рабочих цилиндров	1	2	2	3	1	3	3
(9) Рабочее давление жидкости в кг/см ²	200	200	200	200	—	320	—
(10) Усилие, развиваемое цилиндрами возвратного хода, в т	110	224	234	580	—	925	—
(11) Размеры стола пресса в мм	1 625 × × 1 320	2 000 × × 1 800	2 030 × × 1 780	2 440 × × 2 440	3 505 × × 4 000	5 580 × × 1 910	3 960 × × 1 830
(12) Максимальное расстояние между ползуном и столом пресса в мм	1 524	2 030	2 020	2 540	4 115	3 350	3 650
(13) Максимальный ход ползуна в мм	1 015	1 015	1 015	1 270	—	1 400	3 050
(14) Габариты пресса в плане в мм	6 200 × × 3 850	6 200 × × 3 890	6 200 × × 4 470	8 800 × × 5 300	8 000 × × 5 000	16 050 × × 5 540	—
(15) Высота пресса над уровнем пола в мм	7 100	8 140	8 420	7 370	12 100	9 200	13 035
(16) Общая высота пресса в мм	10 500	12 200	13 000	10 800	16 000	13 940	17 100
(17) Ориентировочный вес пресса в т	196	272	425	800	—	1 000	—

Форм. 38 и 39	Форм. 40	Форм. 41	Форм. 42-43	Форм. 44	Форм. 45	Форм. 46	Форм. 47	Форм. 48	Форм. 49-51	Проект- ные дан- ные
15 000	16 200	22 500	30 000	31 500	31 500	31 500	45 000	45 000	68 000	68 000
3	4	8	8	8	8	6	9	16	12	10
350	320	320	450	—	—	—	—	—	—	350
900	—	—	1 000	—	—	—	—	—	9 900	—
6 000 × × 2 000	3 760 × × 2 160	8 400 × × 3 1 750	10 000 × × 3 470	8 220 × × 2 100	6 920 × × 3 460	9 300 × × 3 660	9 900 × × 3 700	7 925 × × 3 660	12 800 × × 3 700	12 800 × × 4 100
2 500	3 060	3 600	2 700	3 350	4 575	3 600	4 200	—	4 575	2 745
1 400	1 525	1 500	1 800	1 830	2 440	1 830	1 830	1 830	1 830	2 135
26 000 × × 8 100	—	—	36 810 × × 7 100	—	—	—	—	—	—	—
10 600	9 760	—	16 400	10 000	15 280	14 000	15 000	15 544	—	—
15 825	14 500	26 300	24 620	21 945	26 620	34 000	35 000	26 520	—	—
2 000	2 250	5 400	5 200	—	—	—	—	—	—	—

Key: (1). Designation of the parameter. (2). Fig. (3). Specifications. (4). Maximum effort/force, developed with press, in t. (5). Number of working cylinders. (6). The operating pressure of liquid in kg/cm^2 . (7). Effort/force, developed with the cylinders of recurrent course, in t. (8). Sizes/dimensions of bolster in mm. (9). Maximum distance between slider and bolster in mm. (10). Maximum slider stroke in mm. (11). Dimensions of press in the plan/layout in mm. (12). Height/altitude of the press above floor level in mm. (13). The overall height of press in mm. (14). Tentative weight of press in t.

Page 52.

The precision/accuracy of stampings also affects the elastic nonuniform compression of die/stamp, die base-plates and other parts of the press, whose value is commensurated and even it exceeds the saggings/deflections of table and crosshead during the stamping the small, but requiring high specific pressures of stampings. To fight with an inaccuracy in the stampings, which are obtained due to the nonuniform elastic compression of the parts of press, is possible by the corresponding correction of the figure of die/stamp.

During stamping of fins, thin-walled parts large specific

pressures are required; therefore for the majority of parts the sizes/dimensions of dies/stamps prove to be incommensurably less than the sizes/dimensions of table and crosshead. Since the latter in the powerful/thick presses are performed by composite ones, but not in the form of the solid arrays, which do not have bending strain as rams in the hammers, specific pressures on the table and the crosshead must not exceed 800-1000 kg/cm². With the large loads the local consumption/production/generation of the surfaces of table and crosshead occurs. For obtaining the specific pressures indicated load on the table and the crosshead from the dies/stamps it is necessary to transfer through the thick plates/slabs, laid under the dies/stamps. Therefore the stamp space of press, i.e., the maximum distance between the surfaces of table and the crosshead, selects taking into account the arrangement/position of these die base-plates.

During stamping of forgings the construction/design of press is loaded eccentrically, since center of pressure on the forging, as a rule, is not furnished along the center of press. Center-of-pressure travel from the axis of the symmetry of press occurs as a result of the dissymmetry of the forgings to be stamped, uneven heating of blanks, nonuniform lubrication of the surfaces of the die/stamp and other factors.

With the eccentric loading of press its crosshead, which carries the upper die, is distorted, which negatively affects the precision/accuracy of the sizes/dimensions of the parts to be stamped.

Therefore the creation of mechanisms or devices, which ensure the undistorted motion of the crosshead under the effect on it of the moment/torque, which appears with the eccentric loading, is one of the complex problems, decided during the construction of presses. The system of the hydraulic cylinders, which receive moments/torques from the eccentric application of load (Fig. 32), is the most widely used device, used for these purposes.

The drive of the powerful/thick presses (by effort/force of more than 5000 t) is accomplished/realized from the pump-and-battery stations with the pressure of working fluid 320 kg/cm². In many of the constructed presses the operating pressure is accepted 400-450 kg/cm², which is created by the multiplier adjustable in press.

Page 53.

The large overall dimensions of table and crosshead are the design feature of powerful/thick hydraulic stamping machines, which with the large efforts/forces, developed with presses, leads to the

need of applying the new design concepts of presses and the use/application of composite constructions/designs of their basic parts. If presses with a force of 15000-25000 t can be constructed column (with the common performance of columns) and with a number of working cylinders of not more than four, then for the presses with the large forces the realization of this construction/design proves to be difficult.

Weights and overall dimensions of the parts of press by effort/force 15000 t are almost maximum for the contemporary machine building plants. Thus, for instance, press by effort/force 15000 t, shown in Fig. 38 and 39, has columns with the diameter of 840 mm (along the thread) and with the length of 14480 mm, that weigh at 57500 kg each.

In this press upper cross-beam is comprised of five casts: two with a weight of 40 t and three - of 82 t; the crosshead is comprised of three casts with weights: the first of 94.8 t, the second and the third - on 47 t. Lower cross-beam is comprised of three casts, two of which with weight of 65 t and one, 105 t. The table of this press (plates/slabs) weighs 58.3 t.

Corner post-type press by effort/force 22500 t (Fig. 41) has columns with an outside diameter of 1090 mm, a length of 20730 mm,

that weigh in the machined form on 126.9 t each. For manufacturing this column was required the ingot by the weight of 269 t, which was hammered on the press by effort/force 12600 t.

For guaranteeing of reliability and service life of the press of column they manufactured from alloy steel with 2.25-3% of nickel and 0.3-0.4% of molybdenum. The use of alloyed steel considerably complicated their manufacture. Presses with the effort/force of more than 22500 t in the majority of the cases perform from several sections. The construction/design of press by the effort/force 30000 t, comprised of two sections, it is shown in Fig. 42 and 43. Press has eight working cylinders with the diameters of the plungers of 1050 mm and eight columns with the diameter of 805 mm and a length of 21200 mm.

Working cylinders on four are installed in the upper cross-beams, not connected with each other. These cross-beams are carried out composite/compound, each of two parts. Plungers transfer efforts/forces to the composite/compound crosshead through the massive, rigid plates/slabs.

The base/root of press is carried out in the form of the cross beam, comprised of two cast parts, which rests on the side cross-beams, connected with columns with the upper cylinder cross beams.

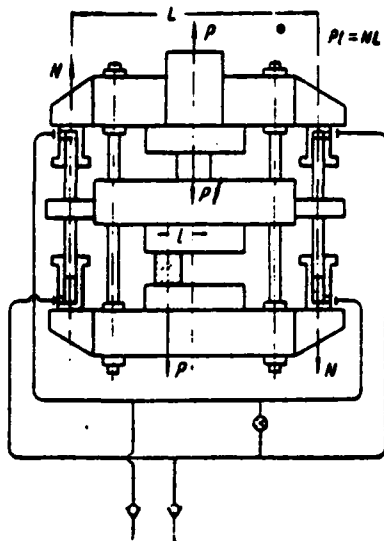
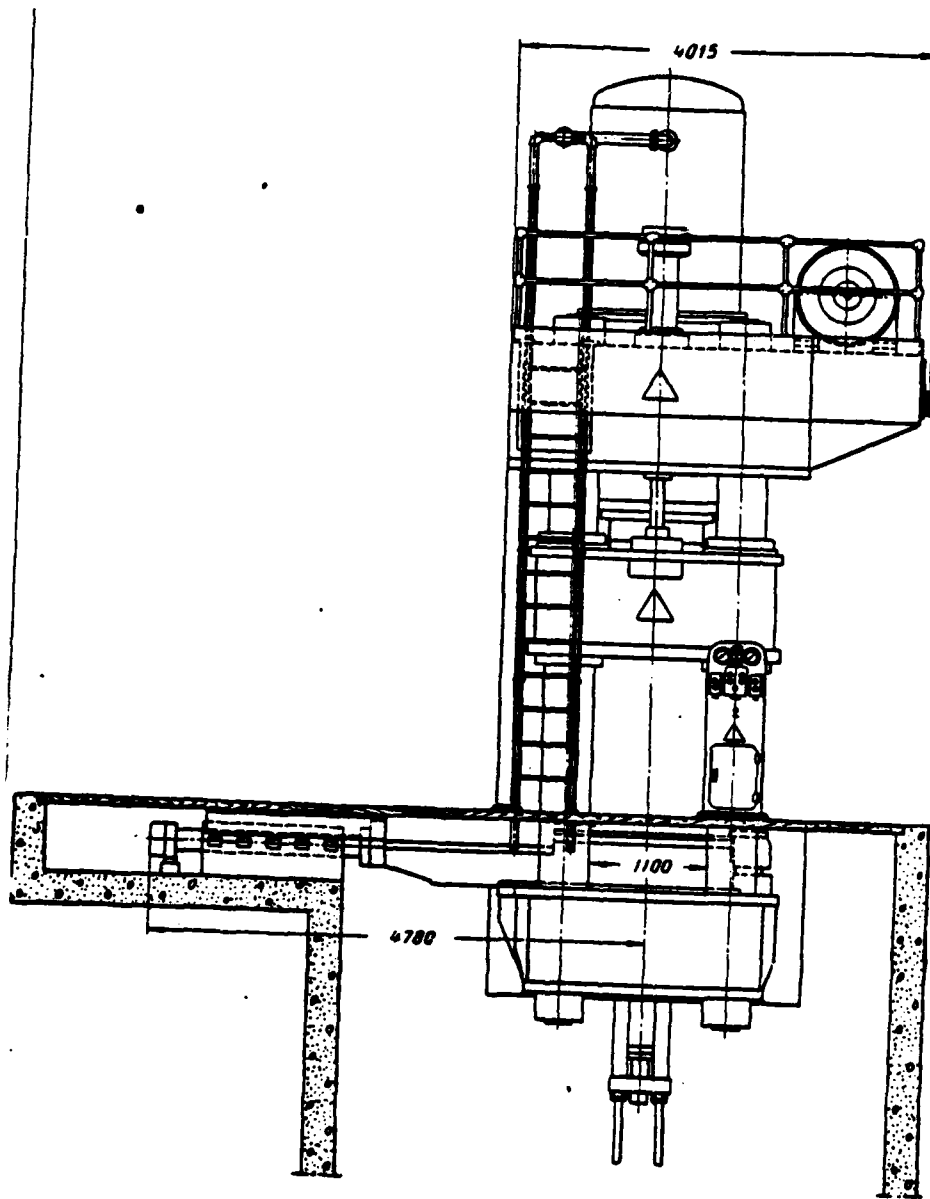

Fig. 32. Diagram of connection of the cylinders, which receive moments/torques from the eccentric load application in the press.

Pages 54-55.



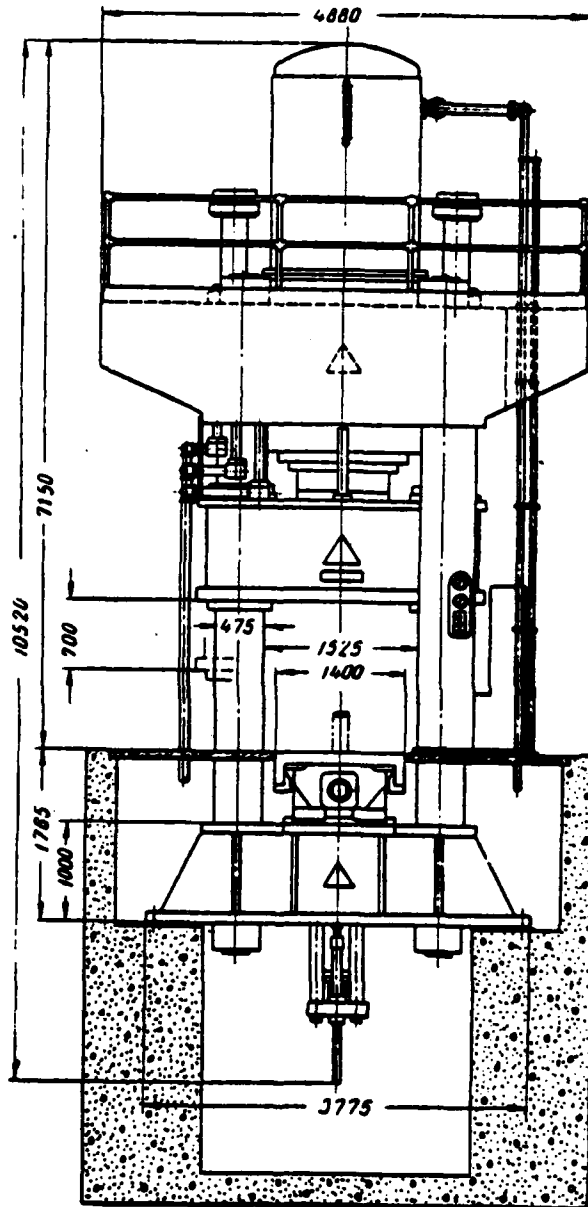

Fig. 33. Single-cylinder hydraulic stamping machine by effort/force 2000 t (with the individual pumping drive).

Page 56.

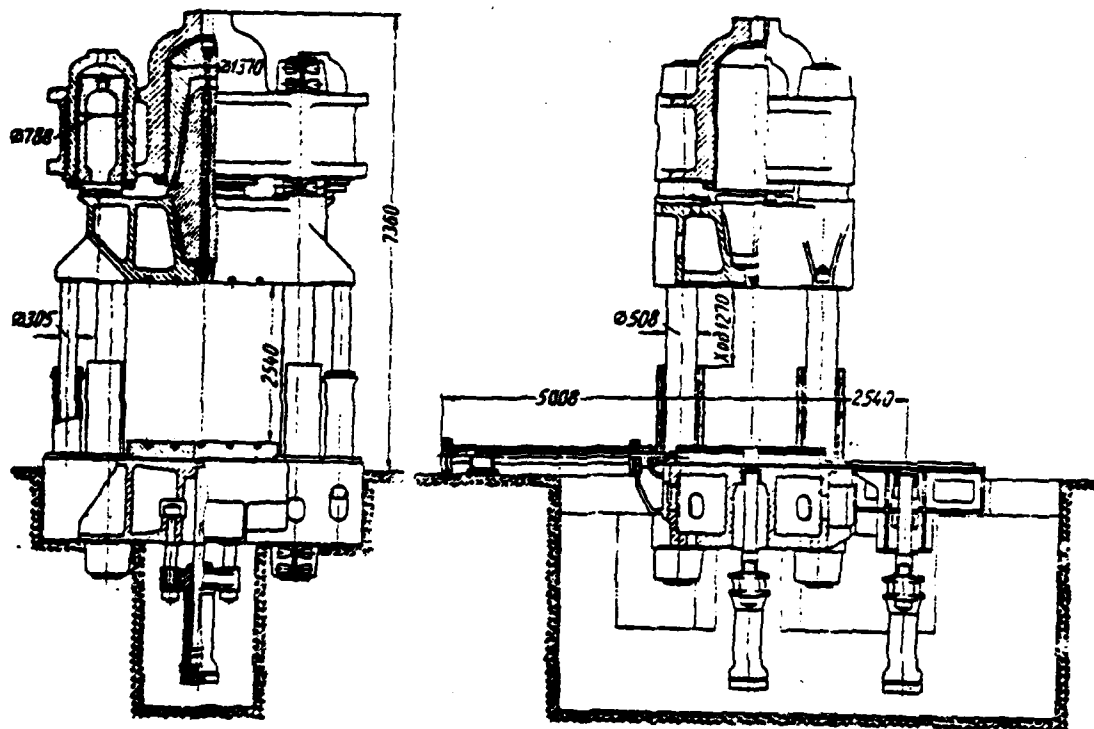

Fig. 34. Three-cylinder hydraulic stamping machine by effort/force 5000 t.

Page 57.

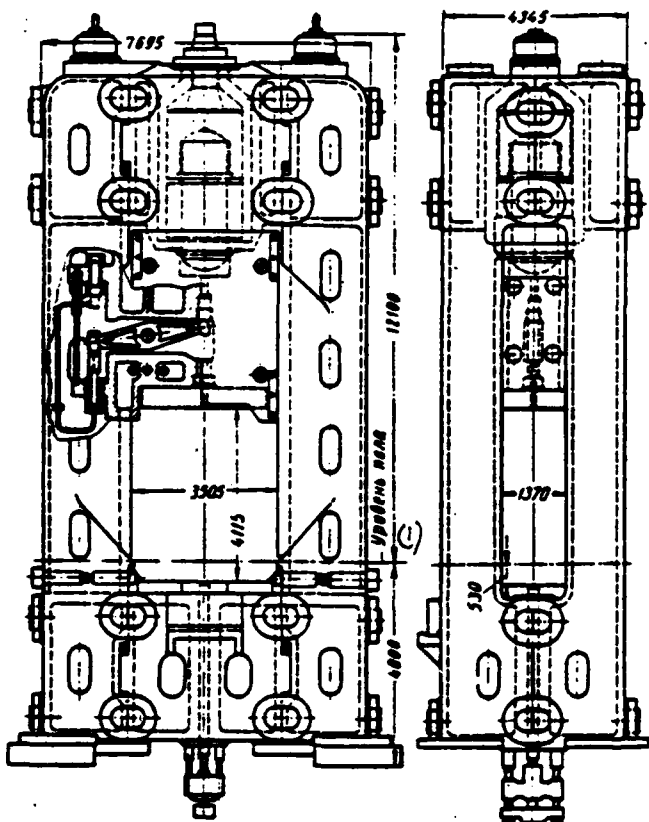

Fig. 35.

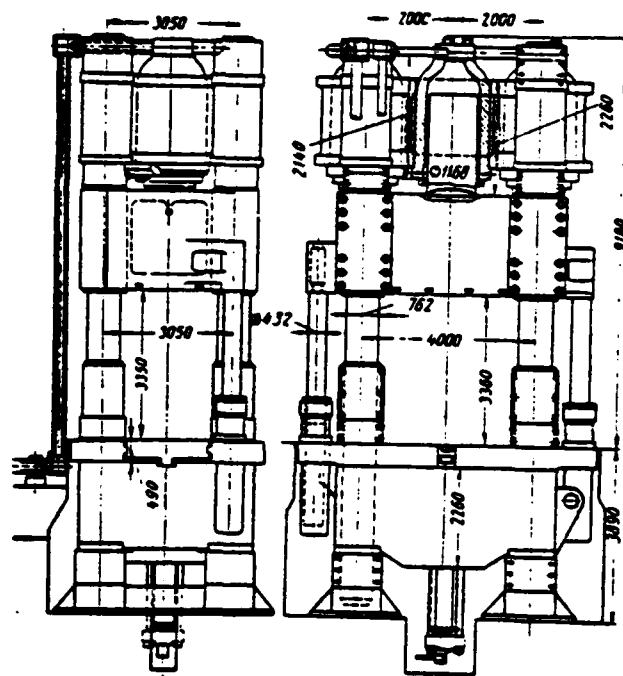

Fig. 36.

Fig. 35. Hydraulic stamping single-cylinder machine by effort/force 7200 t with the mounting of frame construction.

Key: (1). Floor level.

Fig. 36. Three-cylinder hydraulic stamping machine by effort/force 10000 t.

Page 58.

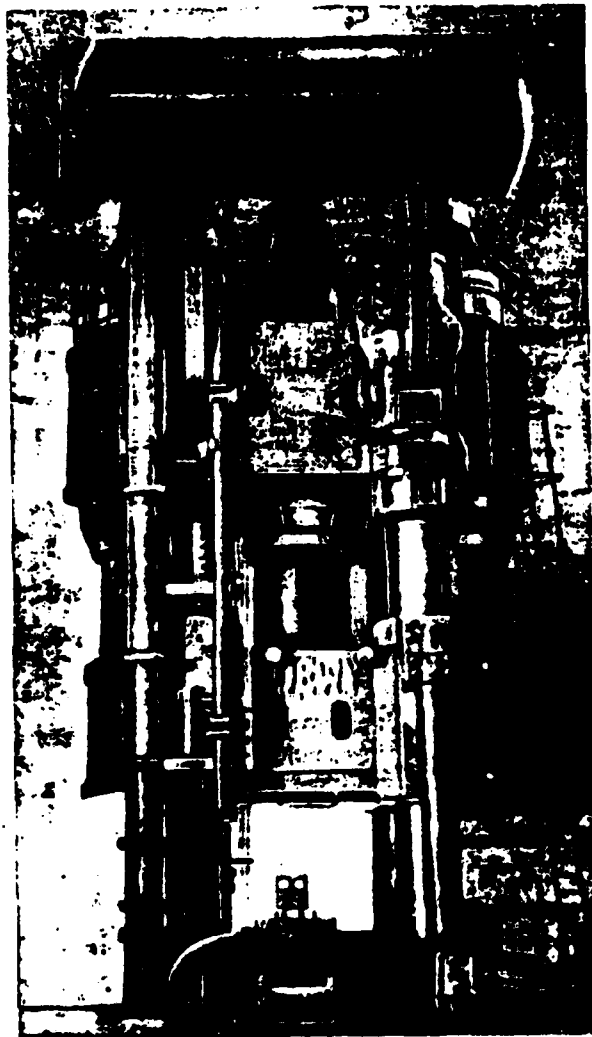

Fig. 37. Three-cylinder hydraulic stamping machine by effort/force 10800 t.

Page 59.

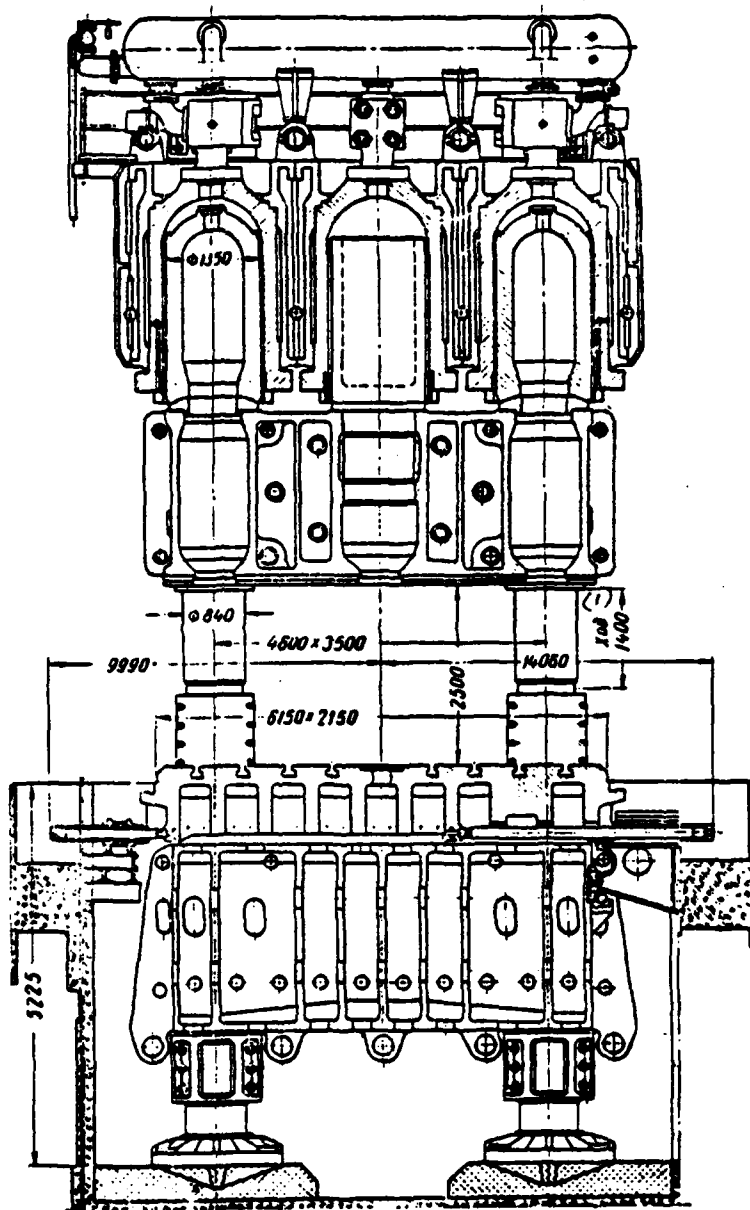

Fig. 38. Three-cylinder hydraulic stamping machine by effort/force 15000 t. Section/cut along the longitudinal axis.

Key: (1). Course.

Page 60.

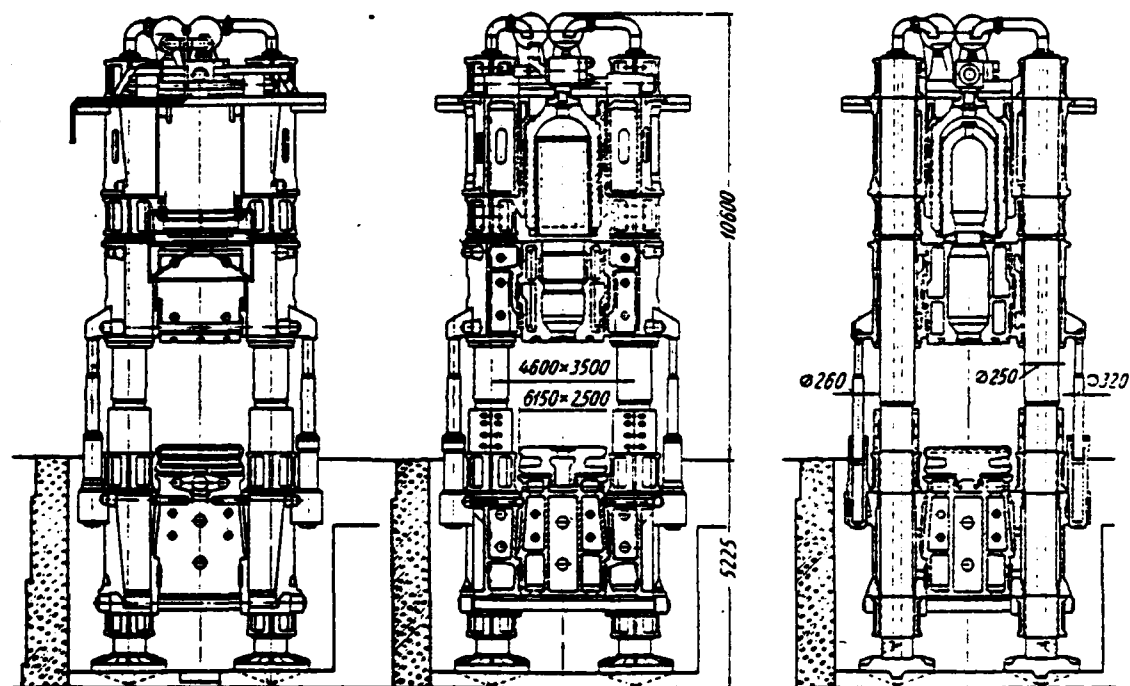

Fig. 39. Three-cylinder hydraulic stamping machine by effort/force 15000 t. Side view and sections/cuts along the transverse axes.

Page 61.

Is somewhat differently carried out the construction/design of

press by the effort/force 31500 t, shown in Fig. 44.

The lower base/root of this press is carried out without the cross beams, which reduced the length of columns, but it led to the fact that part, of which lower base/root is comprised, it was necessary to make more massive.

The columns of this press have a diameter of 864 mm, a length of 18605 mm and weighs 90 t each.

In this press the possibility of the installation/setting up of two additional beams/gullies with the cylinders, which affect in the horizontal plane, is provided for.

Press by effort/force 45000 t, constructed by the firm Mesta (USA), has eight columns with an outside diameter of 1016 mm and a length of 23164 mm (Fig. 48). The weight of the column of this press in the finished form is equal to 137 t.

The primary construction of press consists of sixteen heavy casting, for manufacturing the majority of which were required the ingots by the weight of 300 t and more.

The difficulties of manufacturing large-size and heavy casting

for the presses by efforts/forces 30000-45000 t, and also prospect for the construction of more powerful/thicker presses led to the creation of the fundamentally new construction/design of press with pulling type lamellar composite columns, transmitting effort/force hammer heads, and with the traverses, assembled from the separate plates/slabs (Fig. 47). In this performance in the USA the presses are constructed with effort/force of 31500 and 45000 t.

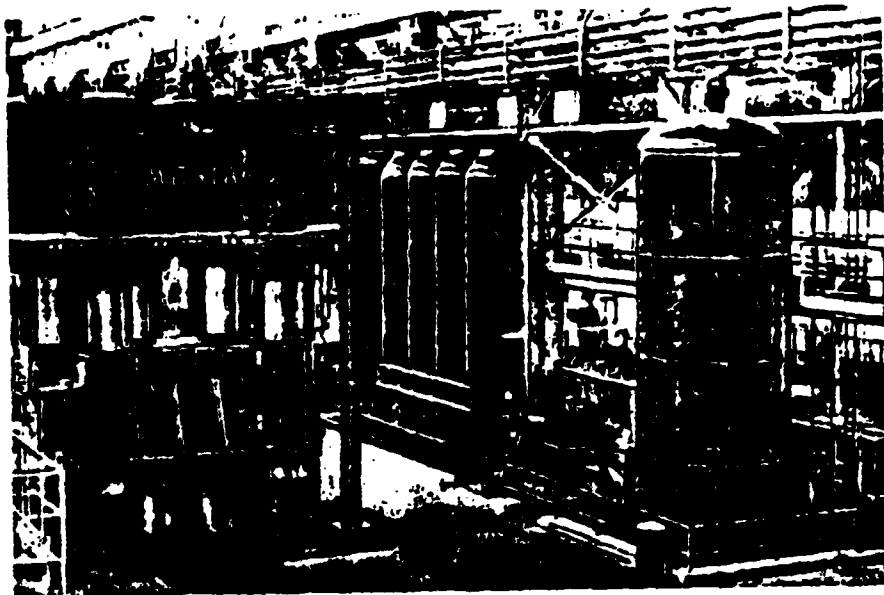

Fig. 40. Four-cylinder hydraulic press by effort/force 16200 t.

Page 62.

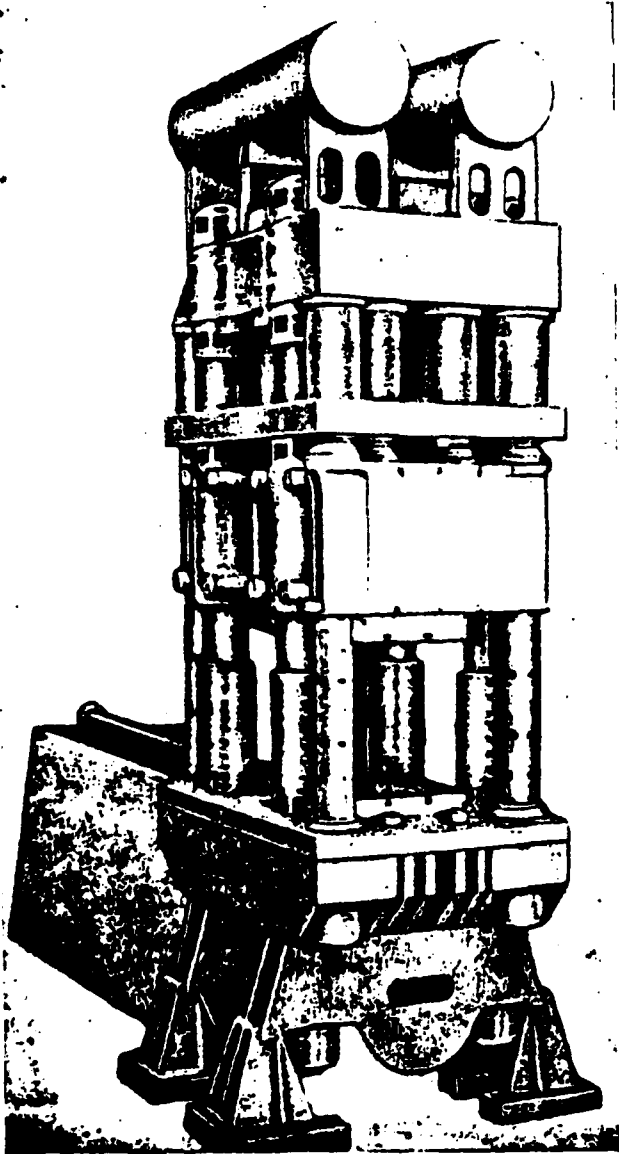

Fig. 41. Eight-cylinder hydraulic press with force of 22500 t.

Page 63.

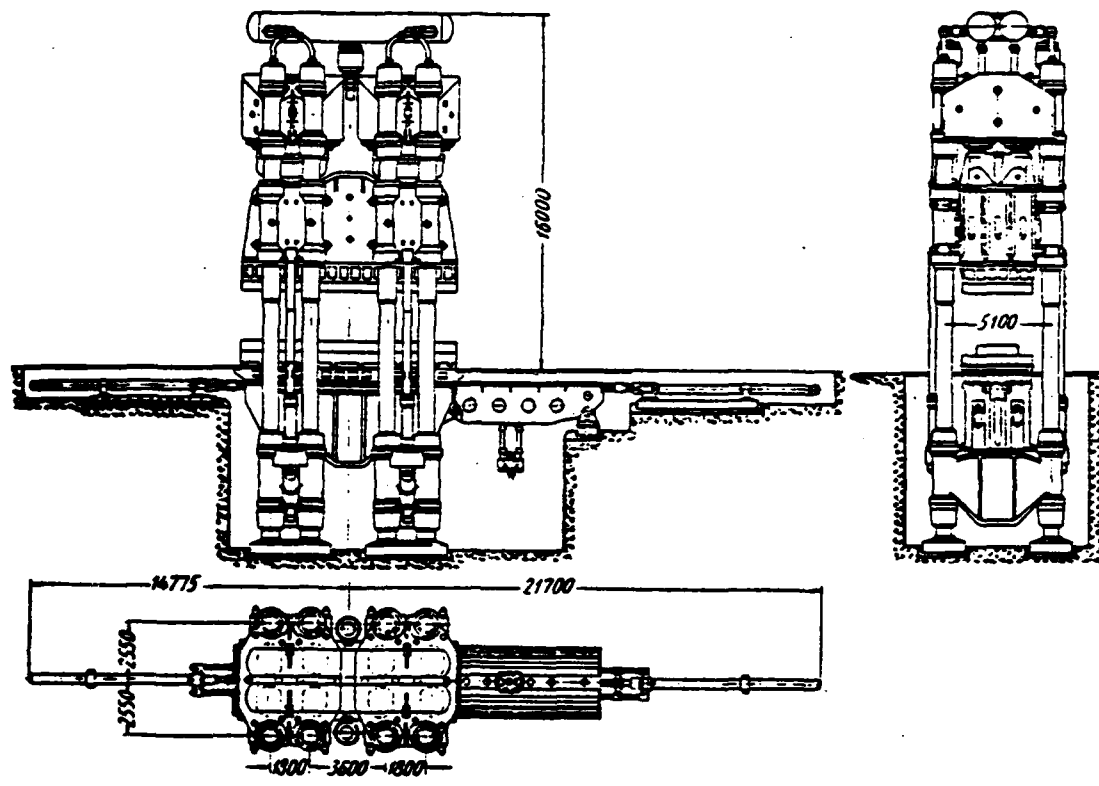

Fig. 42. Eight-cylinder hydraulic stamping machine 30000 t. General view.

Page 64-65.

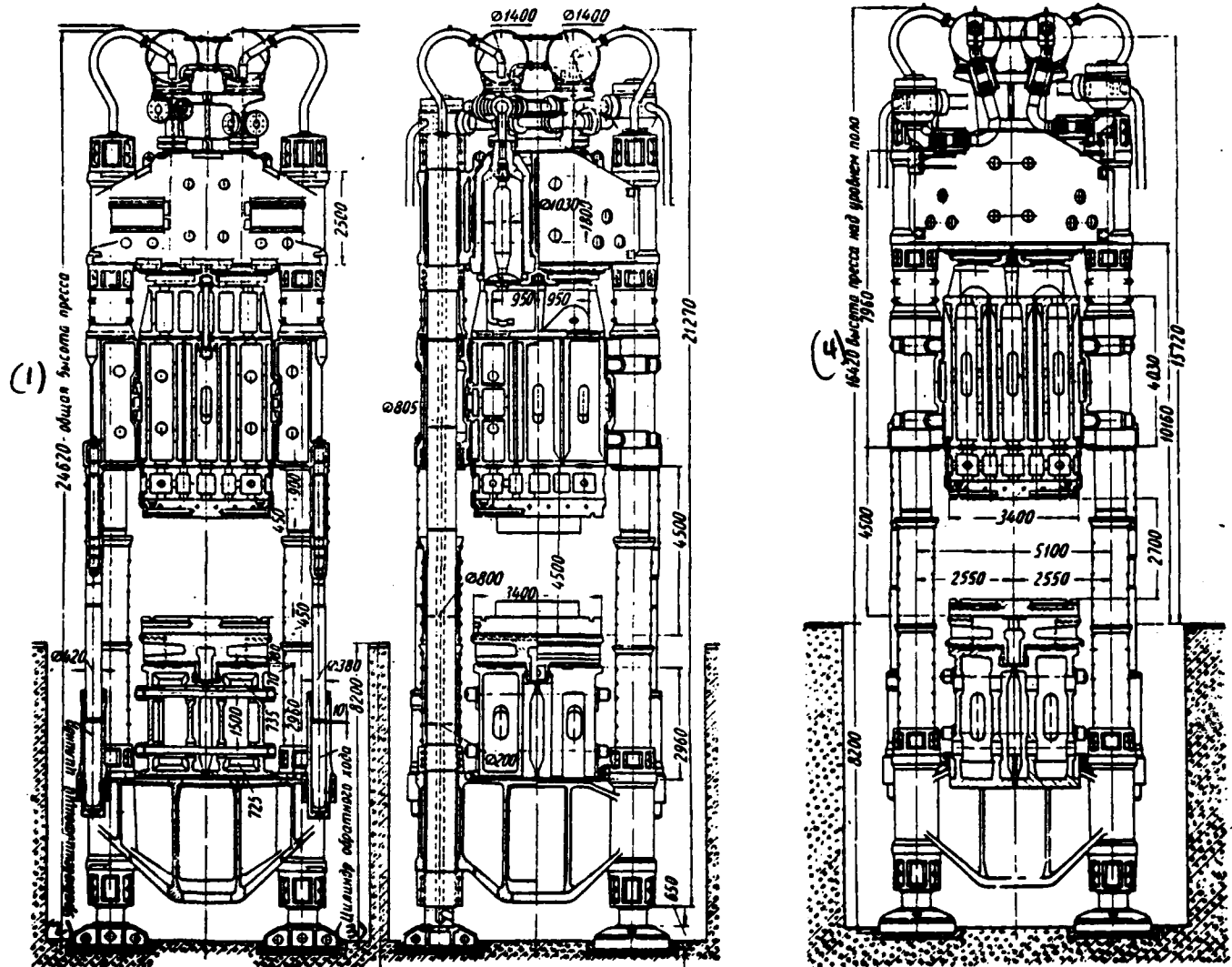

Fig. 43. Eight-cylinder hydraulic press by effort/force 30000 t. Sections/cuts along the transverse axes (see Fig. 42).

Key: (1). general/common/total height of press. (2). Balancing

cylinder. (3). Cylinder of back stroke. (4). Height/altitude of the press above floor level.

Page 66.

Press by effort/force 31500 t is carried out with four columns, by effort/force 45000 t - with six columns. Columns in these presses are comprised of three forged finely finished plates. Each plate of column by effort/force 45000 t has a thickness of 356 mm and a length of 33528 mm. Column in the collection weighs 288 t. Forging plates was produced under the press by effort/force 12600 t, their subsequent straightening/trimming - under the press by effort 5800 t and machining - for the specially created stands.

The working cylinders of these presses are placed under the table, which are for them support.

In the given construction/design of presses the lower arrangement of cylinders is caused by the fact that pulling type columns with the hammer heads cannot absorb the dead weight of crossheads and working cylinders. During the lower arrangement of pressure cylinders they have relatively small dimension on the height/altitude above floor level, which gives the possibility to construct the lower building of shop. The arrangement/position of

working cylinders and basic hydraulic system of lower than the level of the floor of shop creates convenience in the operation of press, dividing the space occupied by it as into two zones - upper, utilized by technologists, and lower, where the mechanics, which lead observation of the work of the hydraulic system of press, work.

There are presses with the circular columns, constructed according to the analogous diagram (Fig. 45). For the stamping machines preferably the performance of frame type mounting as more rigid in the comparison with the column mounting. The example to the constructions/designs of this press is shown in Fig. 35. Press is performed with two knockouts, upper both lower and by side cylinders for installation/setting up and fixation of dies/stamps.

The difficulties of manufacturing the parts of powerful/thick presses and the limitedness of production potentialities forced to search for the new design concepts of presses, in principle different from the known ones. For the presses effort/force 68000 t [6] proposed the construction/design, in which basic carrying part of the press is made from the reinforced, prestressed concrete (Fig. 49). The press does not have columns; its master cylinders rest on the reinforced-concrete mounting, which is the part of the building of shop. The frame of press has sizes/dimensions 36.6x42.7x15.5 of t; compound, where this press is installed, has sizes/dimensions: the

length of 36.6 m, the width of 24.4 m, the height/altitude of 15.25 m.

The absence in the press of columns gives the possibility of approach free from all sides to the dies/stamps of press, thanks to which the goods traffic of blanks and stampings can be rational organized and manipulators for servicing of press are used.

The solution of constructing/designing the press proposed deserves attention, since during this performance the effort/force, developed with press, is not limited.

At the same time this construction/design can prove to be advisable and for the presses of the relatively low powers, installed to one frame.

Page 67.

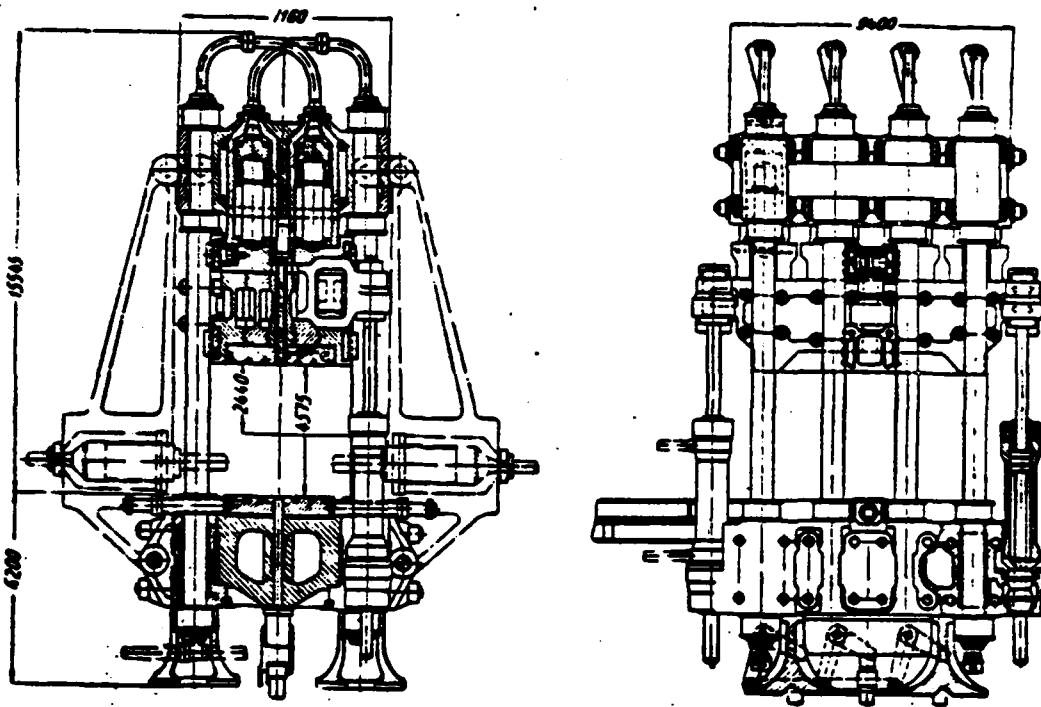

Fig. 44. Eight-cylinder hydraulic stamping machine by effort/force 31500 t.

Page 68.



Fig. 45.

Fig. 45. Eight-cylinder hydraulic stamping machine by effort/force 31500 t.

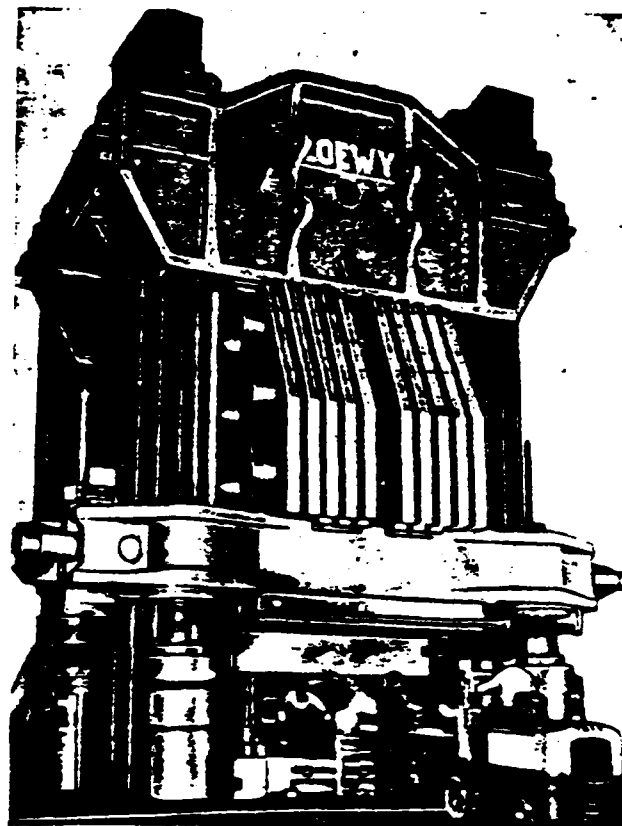

Fig. 46.

Fig. 46. Hydraulic stamping machine by effort/force 31500 t.

Page 69.



Fig. 47.

Fig. 47. Hydraulic stamping machine by effort/force 45000 t.

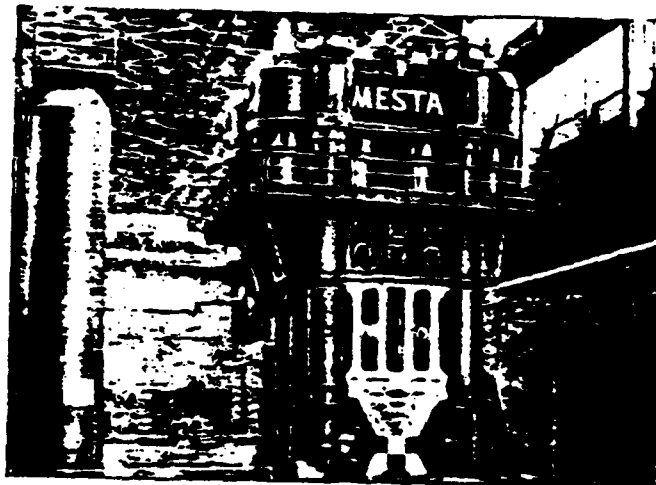

Fig. 48.

Fig. 48. Eight-column hydraulic stamping machine by effort/force of 45000 t.

Page 70.

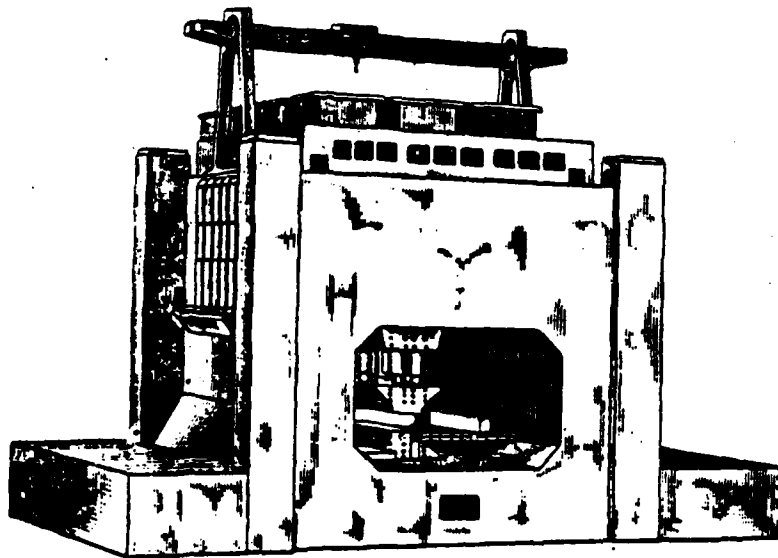

Fig. 49. Hydraulic stamping to press by effort/force 68000 t with the reinforced-concrete mounting (project).

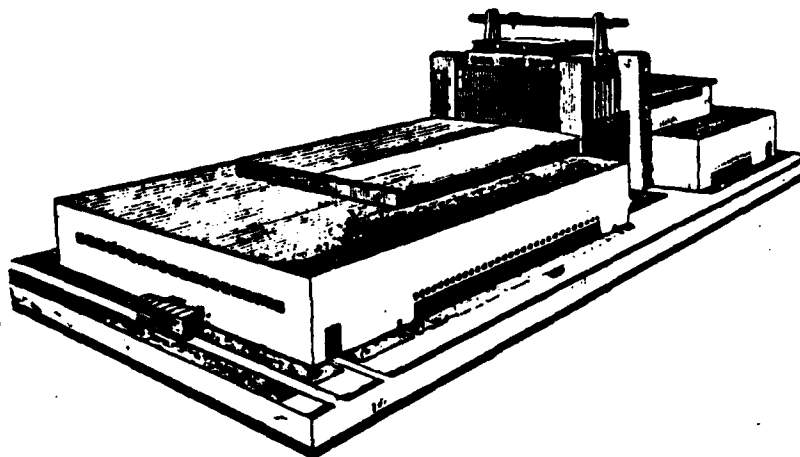

Fig. 50. Hydraulic stamping machine by effort/force 68000 t with the reinforced-concrete mounting, built in the building of plant

(project).

Page 71.

Fig. 50 shows the general view of the mock-up of plant with the built-in in it press with the mounting from the stressed reinforced concrete, while Fig. 51 - the schematic of the reinforced-concrete mounting, designed for the group of presses.

Punch and Bending Presses.

Many parts of different installations/settings up, constructions and machines as, for example, parts of the boiler barrels and vessels different in the construction/design and storage tanks of liquids and gases under the low and high pressure (bottom, frontal walls, shell, etc.), part of housings and skin/sheathing of cargo vehicles are manufactured with stamping and deep drawing or flexible from the sheet blanks, in the hot or cold state, on the hydraulic presses of different constructions/designs and powers.

Cupping, flanged and bending single-column presses.

For sectional stamping and flanging of bottoms and similar parts, flanging of necks, for manufacturing the parts simultaneously

by stamping and by flexible, for the bending under of edges in the sheets, which enter then the rollers, for the straightening of the sheets before the subsequent stamping or flexible and many other works are applied the presses, which have the single-column "open" mounting.

Examples of works on similar presses are shown in Fig. 52.

With the "open" mounting there is a free access to the dies/stamps from three sides of press. With flanging or bending under of the edge of sheet, and also flanging of the necks, situated closely to the edge of part, the overall dimensions of workpiece can considerably exceed the dimension of bolster.

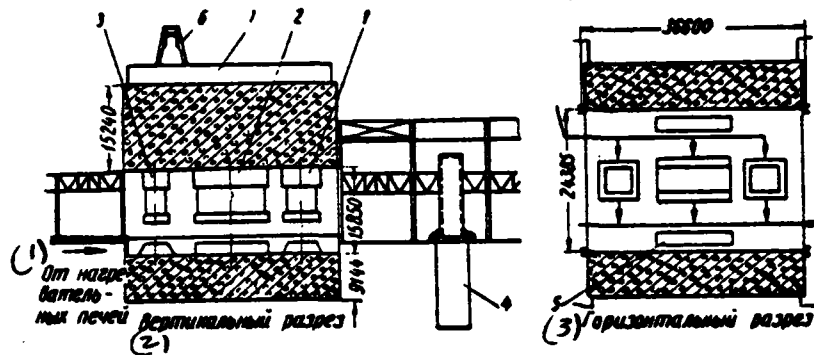

Fig. 51. The schematic of the reinforced-concrete mounting, designed for the group of presses (project): 1 - pressing press; 2 - stamping machine; 3 - trimming press; 4 - bath for the heat treatment of forgings; 5 - manipulator; 6 - crane; 7 - location of the pump-and-battery station.

Key: (1). From the reheating furnaces. (2). Upright projection. (3). Horizontal sectional view.

Page 72.

General-purpose single-column presses are fulfilled with one or two upper vertical working cylinders, one horizontal cylinder and one lower cylinder-pusher, located in the center of bolster (Fig. 53). All pressure cylinders must be fulfilled with the independent control for the possibility of their consecutive use.

Frequently for convenience in servicing press on its mounting are installed booms with the driving/homing or manual block and tackle or the hoists by load capacity 0.5-3 t.

Single-column presses are constructed with the efforts/forces to 500 t and it is rarely above, since in more powerful/thicker presses mountings prove to be excessively bulky. The exemplary/approximate characteristics of general-purpose punch single-column presses are given in Table 8.

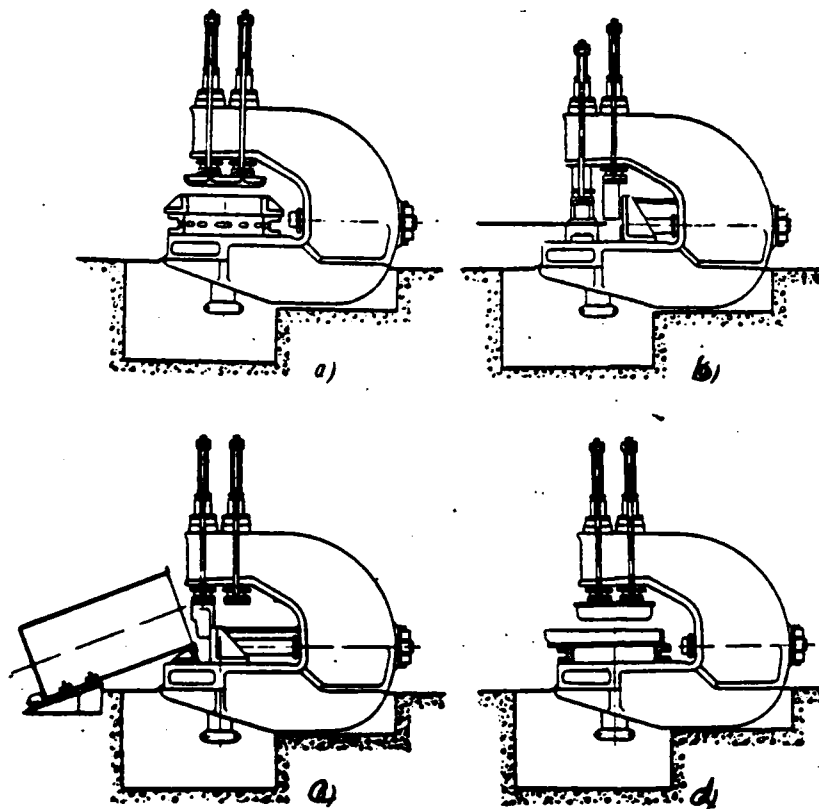

Fig. 52. Examples of the use of the single-column hydraulic press: a) stamping bottom; b) flanging of the edge of sheet; c) flanging of the edge of cylindrical container; d) flanging of neck in bottom.

Page 73.

For the presses of the designated for the accomplishing completely specific operations, for the purpose of simplification in their construction/design, and also achieving great conveniences in the work, it is expedient the parameters and construction/design to

more precisely formulate in accordance with their designation/purpose.

For example, when press is intended for flanging of long sheets, it must be performed with the extended table, which can be hinged/reversible.

The press, intended for straightening the sheets, can have only one upper working cylinder and smooth (without the slots/grooves) table.

For bending of bands or relatively narrow sheets the specialized presses with the narrow and extended along the front tables and the crossheads without the horizontal and lower cylinders (Fig. 54) are constructed.

For the bending under of the edges of sheets, before their flexible into the shells on the rollers, the presses with the working cylinder, arranged/located in underframe (Fig. 55), are convenient for the work.

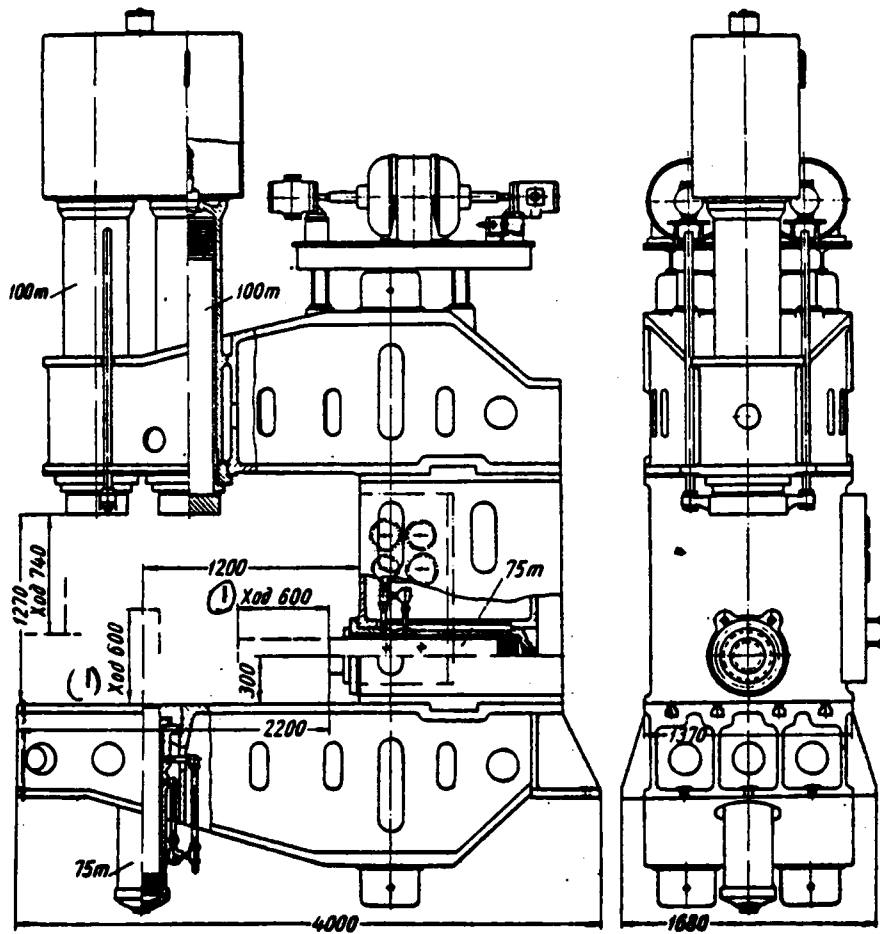

Fig. 53. General-purpose single-column stamping machine by effort/force 200 t.

Key: (1). Course.

Page 74.

Table 8. Exemplary/approximate characteristics of general-purpose punch single-column presses.

(1) Развиваемые усилия в т: верхними цилиндрами при рабочем ходе . . .	150	200	250	350	500
(2) горизонтальными цилин- драми при рабочем ходе	50	75	100	125	175
(3) нижними цилиндрами при рабочем ходе	75	75	75	100	125
(4) Хода плунжеров в мм: верхних цилиндров . . .	750	750	750	1000	1200
(5) горизонтального цилин- дра	900	1000	1100	1200	1300
(6) нижнего цилиндра . . .	600	600	600	600	600
(7) Просвет между "столом и рабочей поверхностью головок верхних плунже- ров в мм	1100	1200	1300	1450	2000
(8) Вылет станины в мм . . .	1500	1500	1500	1700	1900
(9) Размеры стола в мм . . .	1250 × ×2500	1250 × ×2500	1500 × ×2500	1500 × ×2500	3000 × ×4000
(10) Расстояние от стола до оси горизонтального плунжера в мм	250	300	350	400	400
(11) Высота стола над уровнем пола в мм	600	600	450	400	400
(12) Общая высота в мм . . .	6000	6200	6800	7000	7800
(13) Габариты в плане в мм: ширина × длина	1350 × ×4000	1350 × ×4100	1650 × ×4250	2500 × ×4400	4000 × ×5600

Key: (1). Developed efforts/forces in t: by upper cylinders with the working stroke. (2). by horizontal cylinders with the working stroke. (3). by lower cylinders with the working stroke. (4). Piston stroke in mm: upper cylinders. (5). horizontal cylinder. (6). lower cylinder. (7). Clearance between the table and the working injector face of upper plungers in mm. (8). Flight of mounting in mm. (9). Sizes/dimensions of table in mm. (10). Distance from the table to the axis/axle of horizontal plunger in mm. (11). Height/altitude of the table above floor level in mm. (12). Overall height in mm. (13). Dimensions in the plan/layout in mm: width x length.

Page 75.

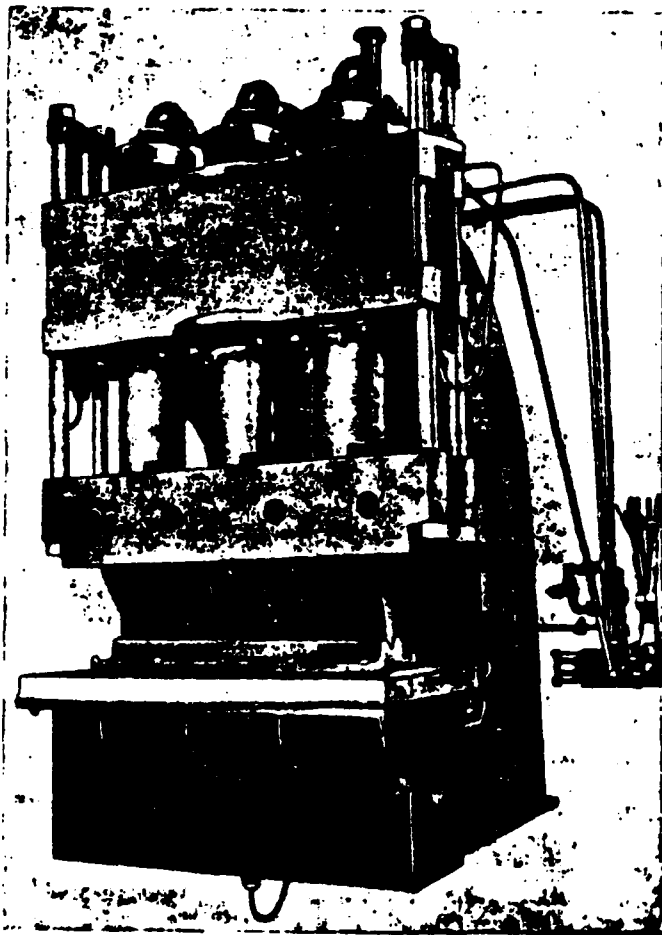

Fig. 54. Bending single-column press.

Page 76.

The mountings of presses, mainly depending on the production potentialities of manufacturing plant, are fulfilled by cast ones or

welded ones, one-piece/entire ones or those assembled from loose parts. An example of a constructive solution of the composite/compound, light construction of mounting is shown in Fig. 56.

In the single-column presses the crossheads do not have a direction on the mounting, and therefore cylinder bushings in them are fulfilled by those extended, which is necessary for reducing/descending the specific pressures on their surface during the eccentric application of load on the plunger.

Single-column presses in the majority of the cases it is expedient to perform with the pumping batteryless drive as ensuring the more sensitive control of the motion of cross-beam and effort/force, developed with plunger. The pump-and-battery drive for these presses can be justified only when they are established/installed in the group with the powerful/thick high-speed presses, fed from the pump-and-battery station.

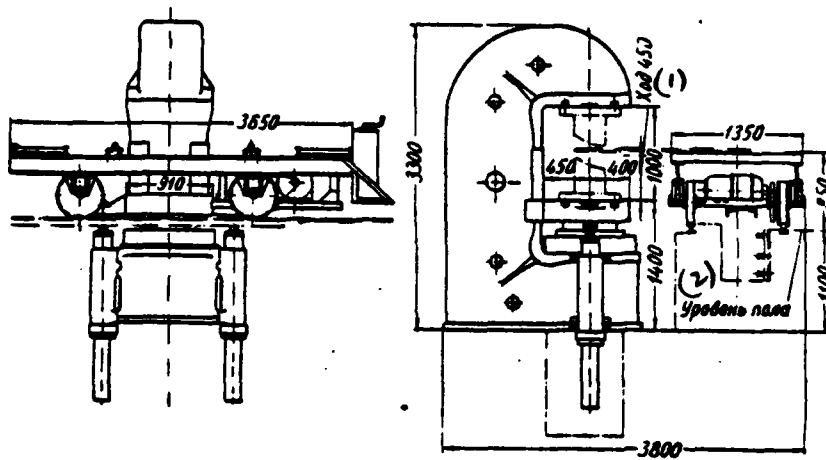

Fig. 55. Single-frame hammer press with a force of 500 t for the bending under of the sterns of sheets.

Key: (1). Course. (2). Floor level.

Cupping column and frame presses.

For stamping the parts from the sheet, for example, of boiler bottoms and different kind of the parts of box-shaped form, are applied corner post-type and frame presses.

Working cylinders in these presses are furnished both in the upper (Fig. 57) and in the lower cross-beam (Fig. 58). Preferably upper arrangement of cylinders, since in this case to more easily carry out mechanization of the supply of sheets into the die/stamp and removal/distance of parts from the die/stamp.

Page 77.

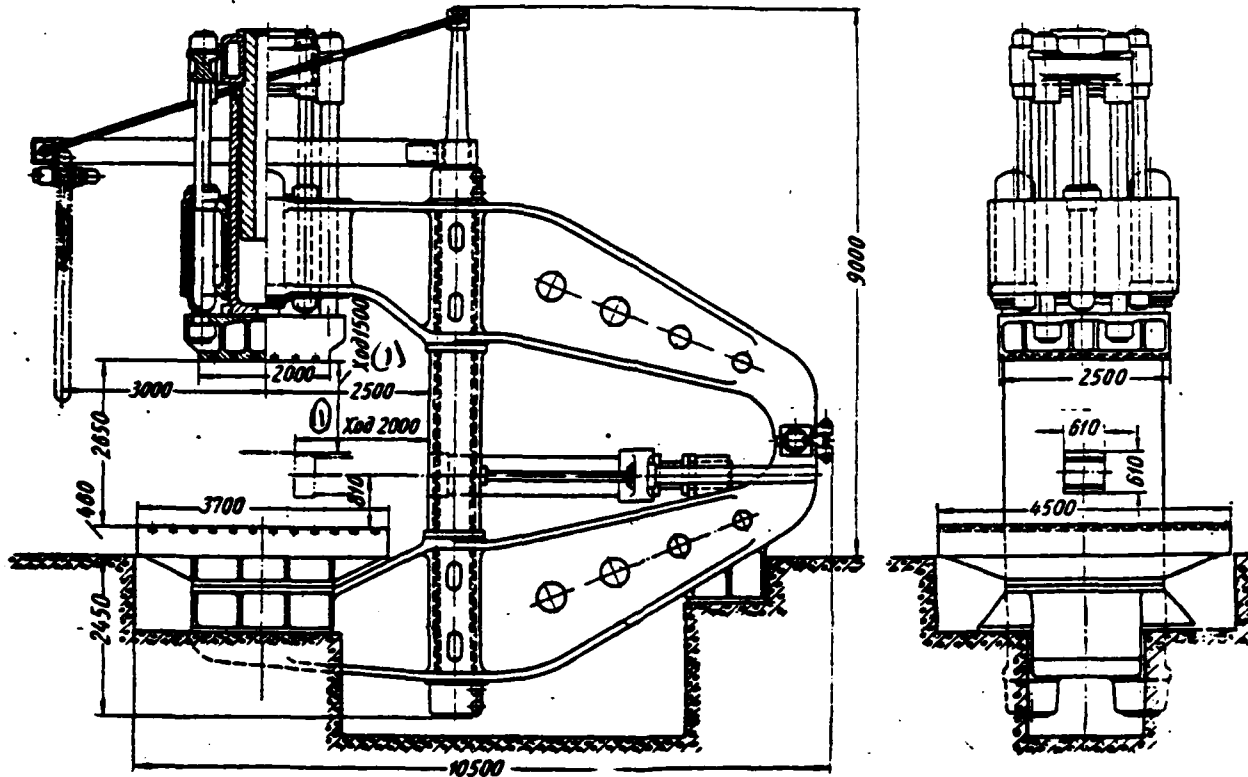

Fig. 56. Hydraulic press by effort/force 500 m with the composite/compound mounting.

Key: (1). Course.

Page 78.

Lower arrangement of cylinders gives the relatively small advantages, which consist in the fact that in this case drops off the necessity

for the pull-backs (cross-beam it is moved to the initial position under the dead weight), which simplifies construction/design, and also gives the possibility depending on the height/altitude of part to change stamp space, lowering or building up upper cross-beam on the columns. Columns in this case at the ends are performed with the extended thread. With the reduced stamp space the rigidity of the frame of press is raised, the oscillations of upper cross-beam are decreased. The connections of the conduits/manifolds, which supply water into the working cylinders, in this case are located in the best conditions.

Contemporary powerful/thick presses usually perform with the extensible table, which ensures the light replacement of dies/stamps and which gives possibility, in the absence of special mechanisms for supplying the sheet into the press and removal/distance of finished parts from the press, to make these operations with the aid of the tap/crane with the advanced die/stamp from the press.

For transmitting the parts from the die/stamp of press they equip with the lower cylinders (knockouts), adjusted in the center of table, and in the presence of extensible table - frequently by two knockouts, of which one is established/installed in center of press, and another in the center of table in its advanced position.

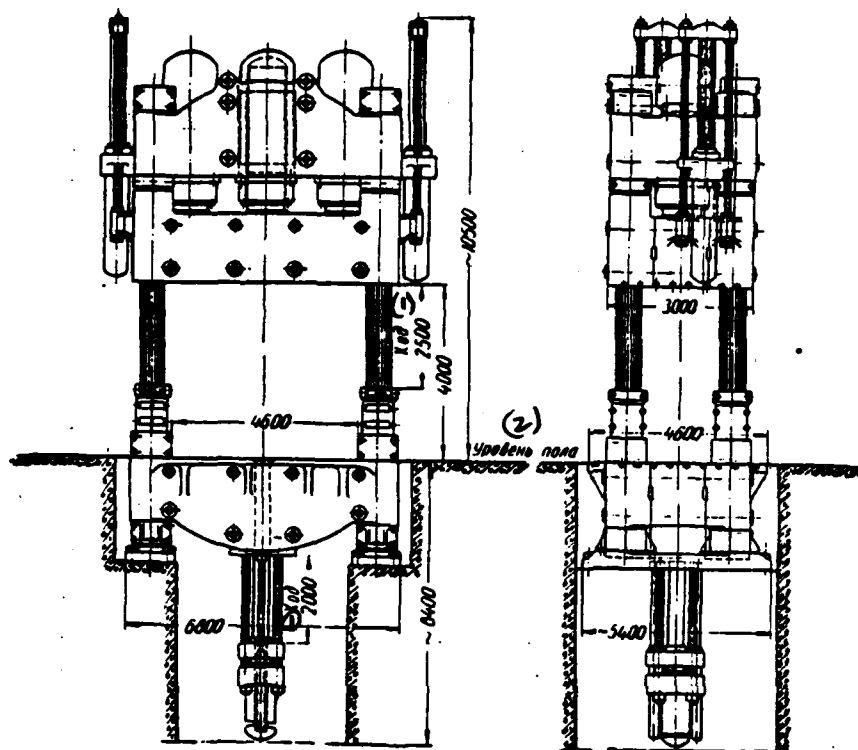

Fig. 57. Corner post-type press with a press of 4500 t for the hot die forging of thick sheets.

Key: (1). Course. (2). Floor level.

Page 79.

Knockout can be used so for the accomplishing and other auxiliary operations as, for example, for the clamp of sheet for the purpose of warning/prevention of its warping/buckling during stamping of

flat/plane bottoms from the relatively thin sheets or for flanging of the necks, located in the center of bottom.

For stamping the parts, which have the flanged necks, situated not on the center, or for the clamp of the sheet of press frequently, they make with the additional auxiliary cylinders: stationary, portable or interchangeable.

Fig. 59 shows corner post-type press with the auxiliary cylinders on the crosshead, while in Fig. 60 - sequence of operations during the stamping on this press of flat/plane bottom with two eccentrically arranged/located necks.

For stamping the flat/plane bottoms with the eccentrically arranged/located necks it is expedient to construct also the specialized presses with the additional lower, crosshead, on which the male die/punch for flanging is fastened.

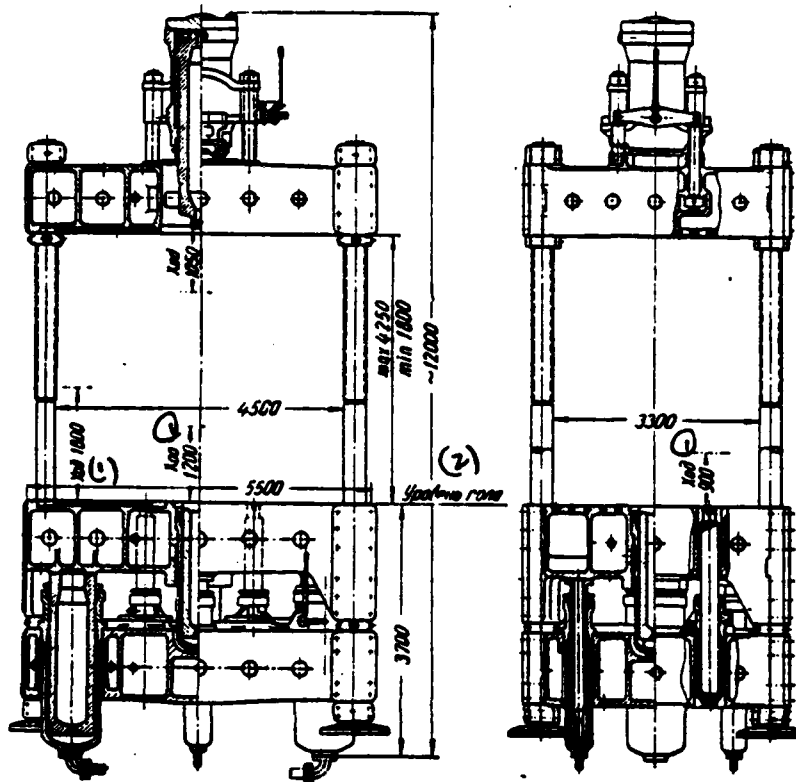

Fig. 58. Corner post-type press by effort/force 1500 t for the hot die forging of thick sheets with the lower arrangement of working cylinders.

Key: (1). Course. (2). Floor level.

Page 80.

The construction/design of this press and the sequence of the fulfilled operations during stamping on it of bottom are shown in

Fig. 61.

At boiler, ship-building, car and other plants many parts stamp from the broad bands. For similar works of presses it must be performed with those extended along the front by the crosshead and table, moreover powerful/thick presses with the large dimensions of table in this case are manufactured with six or eight columns (Fig. 62). Punch column presses are constructed with the efforts/forces to 20000 t (Fig. 63).

The presses of relatively low powers are constructed also with the mounting of frame construction.

For the clamp of sheet, for the purpose of warning/prevention its warpings/bucklings during stamping of press are supplied with the lower pressing mechanisms, which work from the hydropneumatic storage battery/accumulator or from the compressed air. Examples of the use of pressing mechanisms during stamping of parts are shown in Fig. 64 and 65.

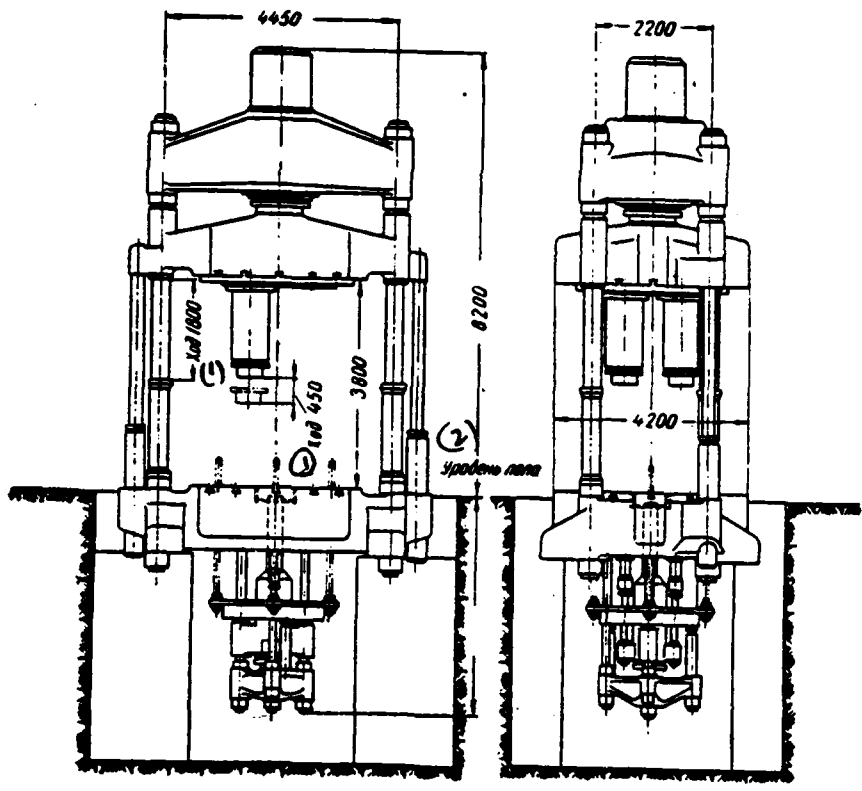

Fig. 59. Corner post-type press by effort/force 1200 t for the hot die forging of thick sheets with the auxiliary cylinders for flanging of necks.

Key: (1). Course. (2). Floor level.

Page 81.

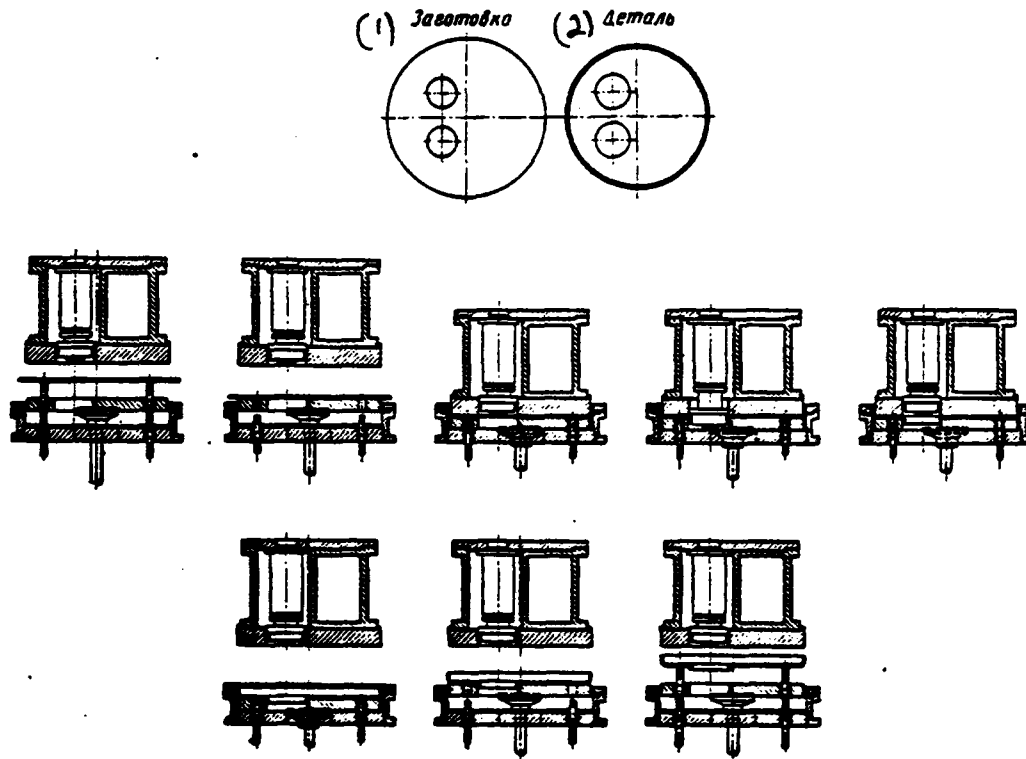

Fig. 60. Sequence of operations during stamping of flat/plane bottom with the eccentrically arranged/located necks.

Key: (1). Blank. (2). Part.

Page 82.

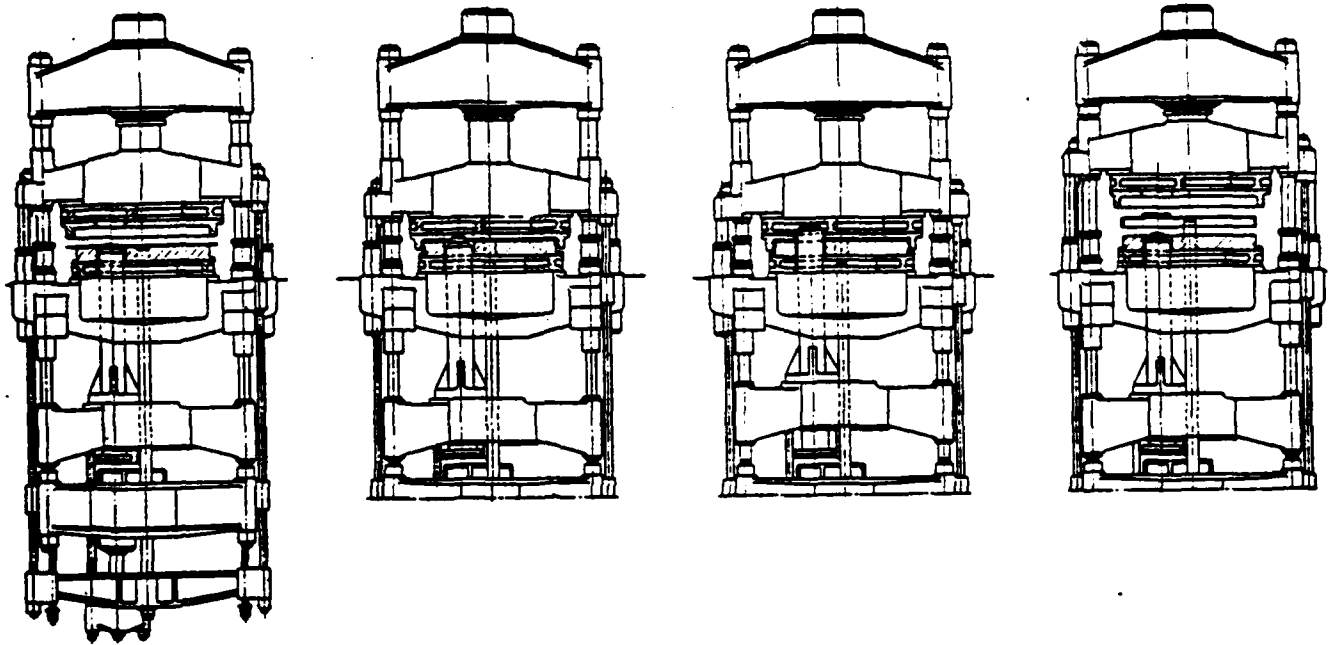

Fig. 61. Fundamental construction/design of the specialized punch press and sequence of operations during stamping on it of bottoms.

Page 83.

For deep drawing of parts from the relatively thin sheets are constructed the presses with two sliders, of which one is intended for drawing of part, and the another for the clamp of the edges of

sheet. The presses indicated are constructed two types: with the internal - the exhaust slider, moving within the external - pressing (Fig. 66), and with the sliders, arranged/located one above another.

In this case upper slider is intended for the same targets, that also external in the first type, and respectively the designation/purpose of lower slider is analogous with internal. In second type presses clamping ring it is linked with the upper slider by the rods, passing through holes in the lower slider. An example of the use of a press with two sliders is shown in Fig. 67.

The effort/force of pressing mechanism they usually designate by the equal to $\frac{1}{2}$, $-\frac{1}{2}$, of the effort/force of exhaust (main) slider. In the presses with two sliders the locking wedges, which fasten both sliders, frequently are applied and then their efforts/forces during the stamping store/add up.

For the effective use of presses for the hot die forging of large-size parts the means of mechanization of the supply of sheets are necessary into the press and the removals/distances of finished parts from the press. For these purposes to expediently apply special machines with the forks for the transfer of sheet and stamped part (Fig. 68), a in the construction/design of press to provide for, with the knockout, the device, similar to that shown in Fig. 59 for the

DOC = 83120705

PAGE

149

procedure of sheet.

It is expedient to accomplish/realize drive of sheet-stamping presses from the individual pumps.

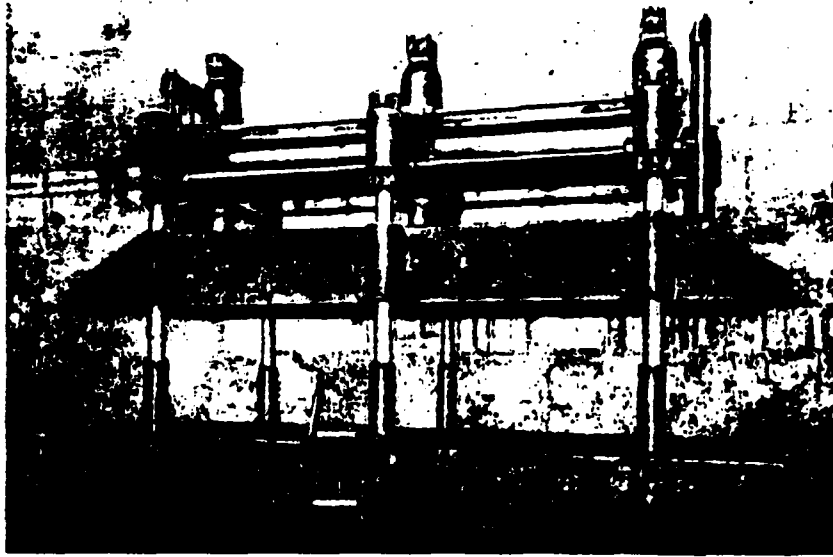

Fig. 62. Six-column punch press.

Page 84.

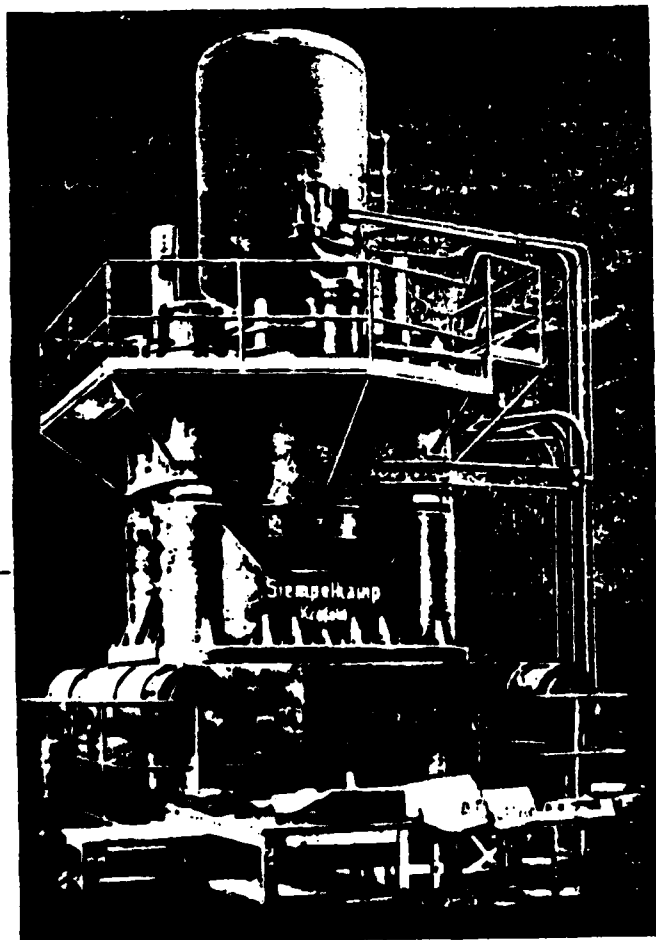

Fig. 63. Punch press by effort/force 20000 t.

Page 85.

The use/application of the pump-and-battery station can be justified only for the powerful/thick high-speed presses, and also for the

group of the powerful/thick presses, intended for the hot die forging.

The selection of press on the effort/force for the drawing is calculated according to the formula ¹

$$P = \sigma_{01} \frac{\pi}{4} (D_n^2 - D_0^2).$$

where σ_{01} - limit of the strength of the extracted material at an appropriate temperature (blank temperature);

D_n and D_0 - respectively external and bores of article (bottom, sleeve/beaker, etc.).

FOOTNOTE ¹. It is necessary to keep in mind that the effort/force, calculated according to the given formula, corresponds to the effort/force, capable to break the extracted part, and is somewhat high against actually that requiring. ENDFOOTNOTE.

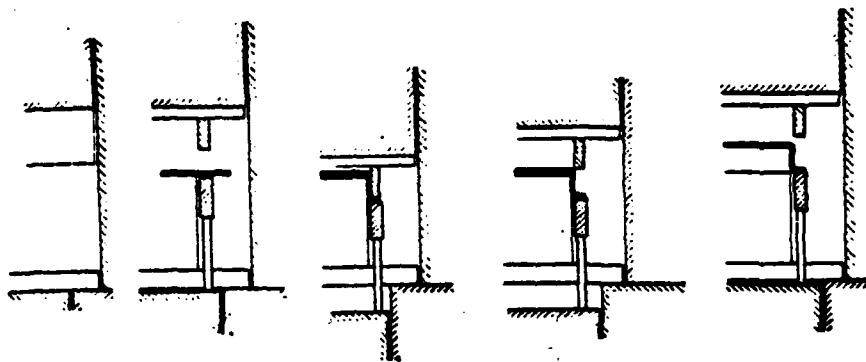

Fig. 64. Use of a lower pressing mechanism for the drawing.

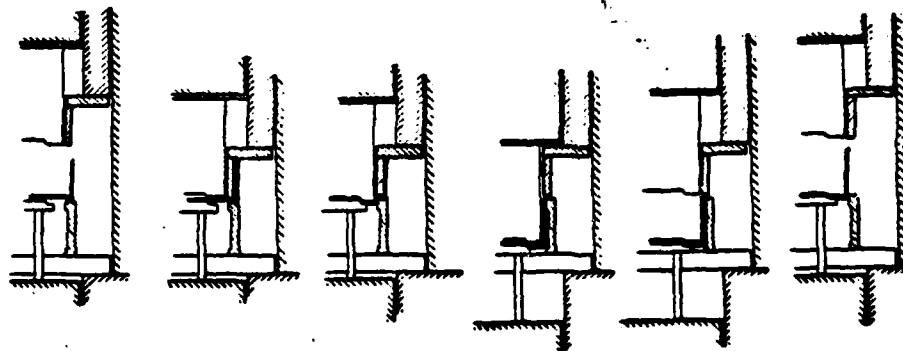

Fig. 65. Redrawing on the double-action press with the use of a lower pressing mechanism.

Page 86.

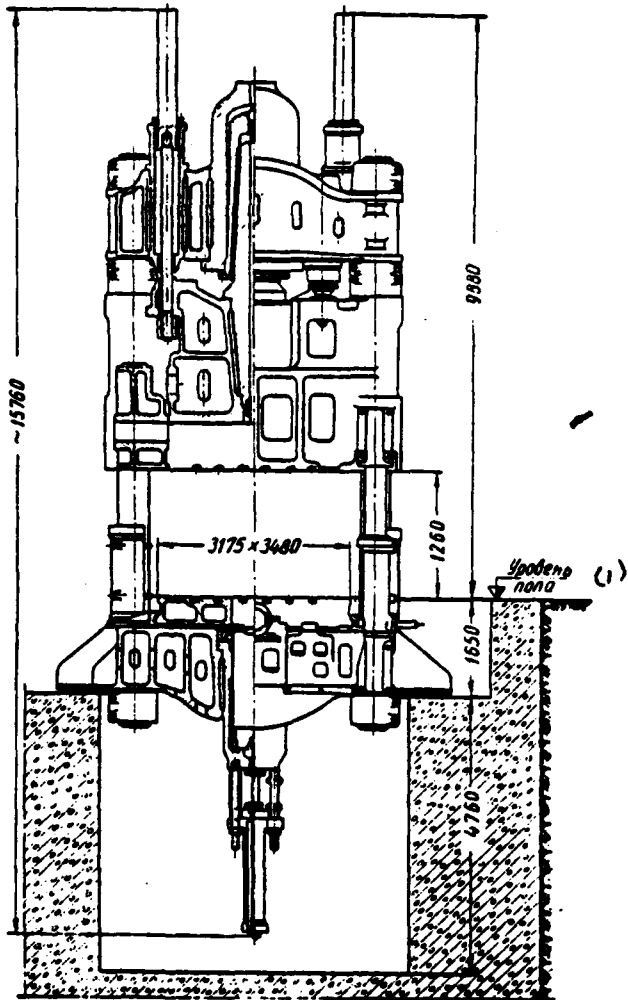

Fig. 66. Blanking double-action press by effort/force 3000 m. Side view and section/cut along the transverse axis.

Key: (1). Floor Level.

Page 87.

The need for the clamp of blank is determined, according to experimental data [9], from the condition

$$D_0 - D < 22t,$$

where D_0 - diameter of blank;

D - the mean diameter of the elongated part;

t - initial thickness of sheet blank.

The specific pressure of clamp on the blank can be determined according to formula [9]

$$q_n \approx 0,056 \left(\frac{D_0}{D} - 1,1 \right) \frac{D_0}{100t} \sigma_{br}$$

Presses for sheet rubber-pad forming and by fraction.

Not long before the Second World War in exchange for metallic dies/stamps and wooden ones, glued ones or with the laminated facing won acceptance the dies/stamps with rubber.

Die is the rubber block, fastened/strengthened to the crosshead of the press; dies/stamps or male dies/punches, on which the formation of laminated parts occurs, they are furnished on the smooth bolster (Fig. 69).

Rubber-pad forming has many advantages in the comparison with the stamping by the common instrument: the manufacture of the expensive matrices/dies is not required, it is not required the sensitive adjustment of male dies/punches, since the latter freely are packed on the smooth bolster; has the capability of the simultaneous stamping of several parts, etc.

At present stamping with the use of rubber dies/stamps extensively is used in the aircraft construction, and also for the production of the objects/subjects of domestic use: radio receivers, metallic toys, metallic packing, etc.

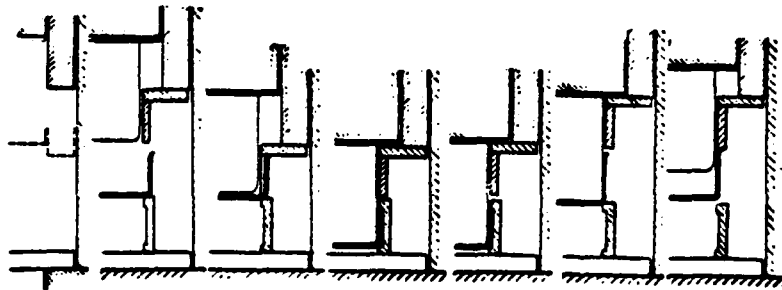

Fig. 67. Sequence of operations of repeated drawings on the double-action press.

Pages 88-89.

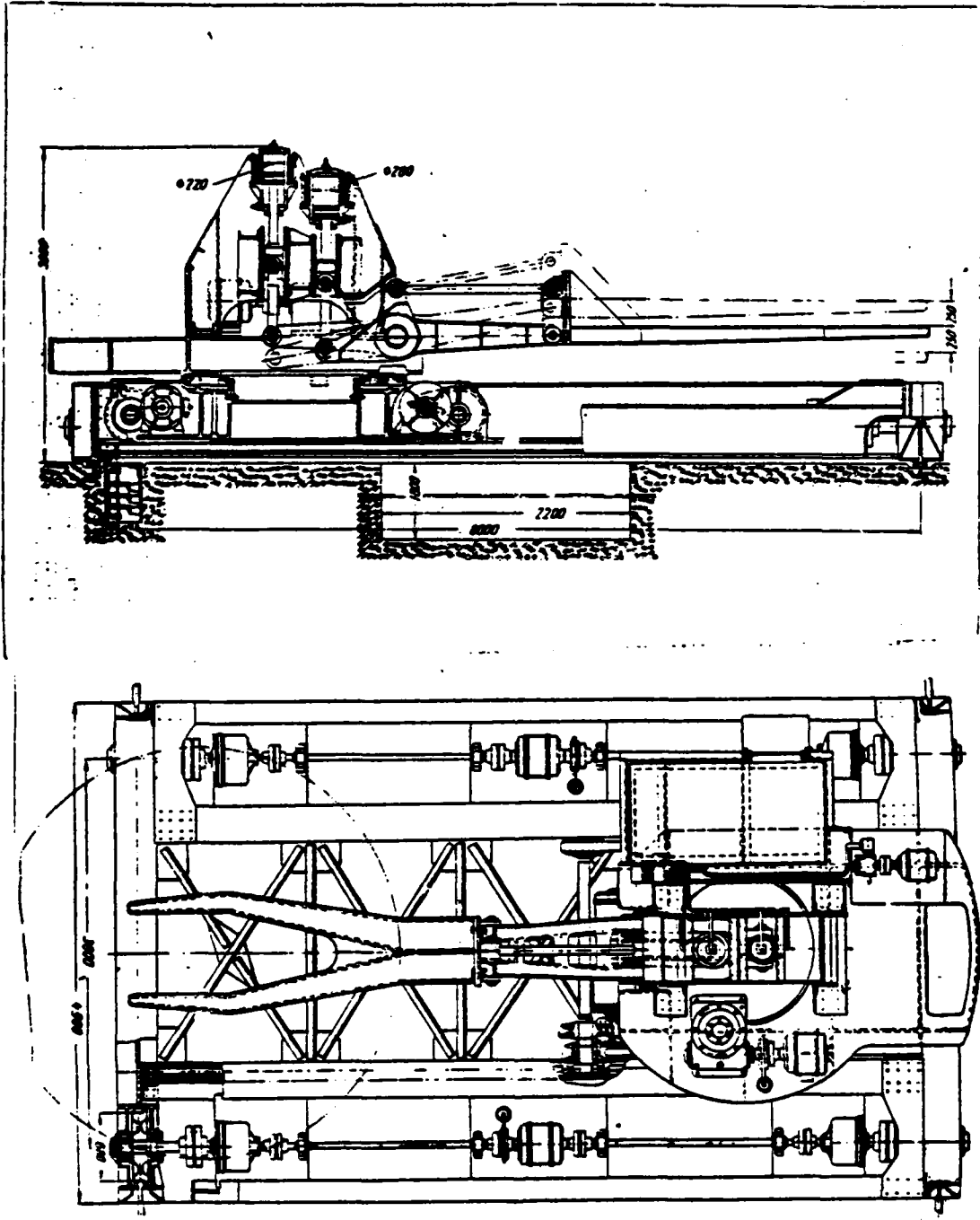

Fig. 68. a loading-unloading machine by load capacity 5 m for the punch press.

Page 90.

For the successful stamping high value has a quality of rubber used. From the rubber pad of the proper quality it is possible to remove/take to 20000 parts from sheet duralumin without the considerable wear of the surface of rubber. Usually rubber, used for the stamping, has a contraction coefficient by 0.05% at a pressure 7-8 kg/cm². The elongation of such a rubber is within the limits of 400-500%.

For rubber-pad forming are constructed the special presses, which have the following special features/peculiarities: considerably smaller stamp space and the smaller slider stroke in the comparison with the common presses for sheet stamping. For the best use of a press the latter is equipped with several tables. While one of the tables is located in the press (in the process of extrusion/pressing), on the rest packing male dies/punches is produced. The successive motion of tables, and also blocking the motion of the crosshead of press and tables are accomplished/realized automatically. Press is shown by effort/force 8000 t with two tables in Fig. 70.

For obtaining the "complete form" of part the crosshead of press with the termination of working stroke they stop and they maintain/withstand certain time under the load.

Presses with the rubber block construct with the drive from the rotation-plunger pumps, which permit implementation of the most varied cycles of the work of press during the accurately coordinated motions of cross-beam and tables. The exemplary/approximate characteristics of presses for rubber-pad forming are given in Table 9.

Table 9. Exemplary/approximate characteristics of presses for rubber-pad forming.

(1) Усилie, развиваемое прессом, в т	1000	2500	2500	5000
(2) Размеры резинового блока, в мм	1500×900	2400×1200	2400×1200	4200×1250
(3) Число выдвижных столов в шт.	2	2	4	4
(4) Мощность насосов в кВт	30	75	75	300
(5) Вес пресса в т	55	115	145	370

Key: (1). Effort/force, developed with press, in t. (2). Sizes/dimensions of rubber block, in mm. (3). Number of extensible tables in pcs. (4). Lifting power in kW. (5). Weight of press in m.

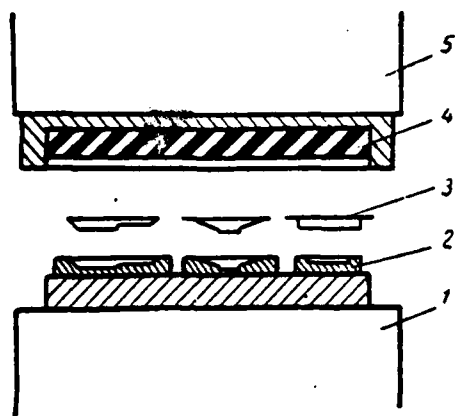

Fig. 69. The schematic diagrams of stamping laminated parts by rubber: 1 - table; 2 - male die/punch; 3 - the part to be stamped; 4 - rubber block; 5 - the crosshead of press.

Page 91. For the creation of the presses of large power with the low sizes/dimensions of table is applied the combined arrangement of cylinders - above pushing action and below, with the support on the table, that pulls actions (Fig. 71).

For rubber-pad forming are constructed the presses (Fig. 72) of fundamentally new construction/design with efforts/forces 10800 and 19500 t [31]. These presses are performed in the form horizontally of the arranged/located "duct/tube/pipe", from the ends/faces on the semicircumferences of that closed with flanges. Instead of the plungers in the presses are used the rubber blankets, on which rubber

blocks are attached.

The liquid, supplied to the upper closed part of "duct/tube/pipe", through the rubber blanket and block presses to the sheet blanks and forms/shapes part on the male dies/punches, packed to the extensible table, which is arranged/located in the lower part of "duct/tube/pipe".

The construction/design, shown in Fig. 72, makes it possible to construct the small and light presses of large power.

At present the process of rubber-pad forming is mastered also for deep drawing. The diagram of stamping with deep drawing is shown in Fig. 78.

So that the blank would not lose stability during the stamping (it was not distorted), are applied clamp blanks to the rubber block. Pressure in the cylinder of clamp is created by the upper slider, to which the container with rubber is fastened/strengthened.

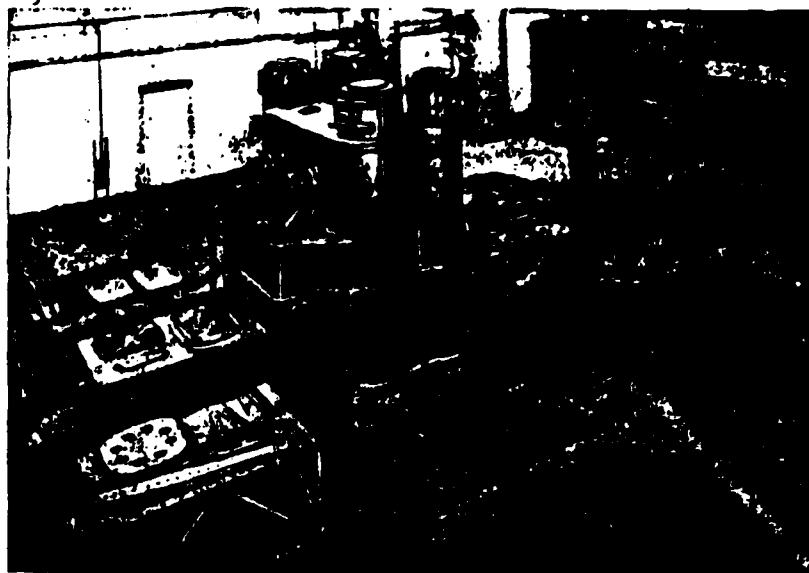

Fig. 70. Press by effort/force 8000 t for rubber-pad forming.

Page 92.

Oil from the cylinder with the piston stroke down, connected with pushers with presser plate, is squeezed out through the throttle adjustable valve. Pressure regulation in the cylinder of clamp is accomplished/realized automatically on the slider stroke with the aid of the cam device how is provided the possibility of deep drawing.

At the termination of the stamping, when slider departs upward, into the cylinder of clamp oil from the storage battery/accumulator, with which the plunger and presser plate return to the initial

position, is supplied in this case the latter fulfills the functions of the stripper of part from the male die/punch.

Stamping parts thus is accomplished/realized on the special presses, which are stood with the effort/force to 6500 t. In the recent time found use the method, with which instead of rubber the fine/small steel fraction (with diameter of 0.68 mm), charged at the depth to 150 mm is applied into the container, which is established/installed on the bolster.

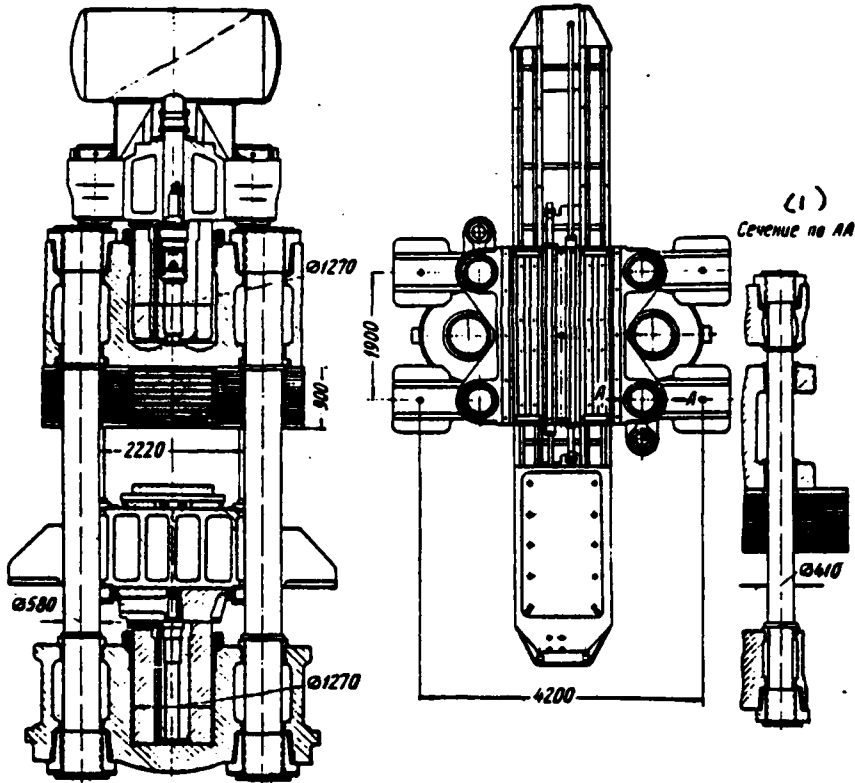

Fig. 71. Punch press with the combined arrangement of working cylinders.

Key: (1). Section/cut throughout AA.

Page 83.

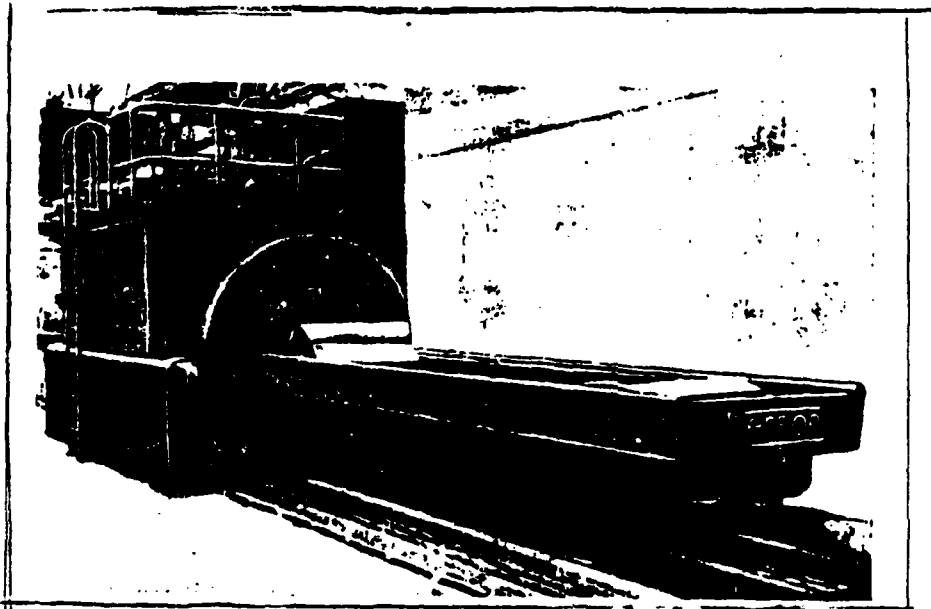

Fig. 72. Press of fundamentally new construction/design for rubber-pad forming.

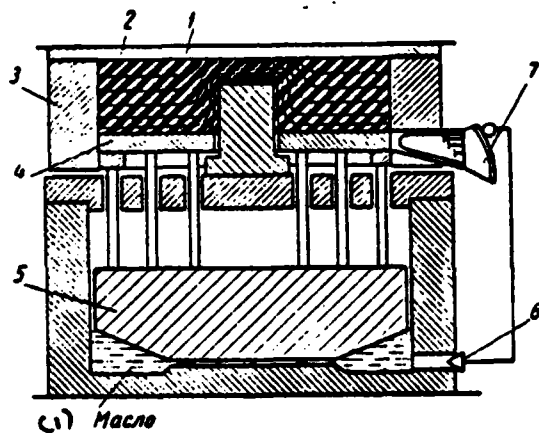

Fig. 73. The diagram of rubber-pad forming with deep drawing: 1 - slider; 2 - rubber pad; 3 - container; 4 - clamp; 5 - drive of clamp; 6 - pressure regulator; 7 - the cam gear of control of pressure regulator.

Key: (1). Oil.

Page 94.

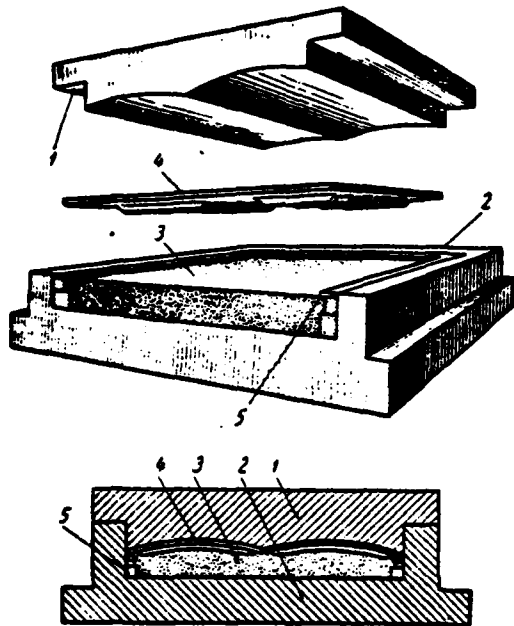

Fig. 74. The diagram of die/stamp with die, filled with shot: 1 - die/stamp; 2 - matrix/die; 3 - fraction; 4 - the part to be stamped; 5 - ring with the friendly.

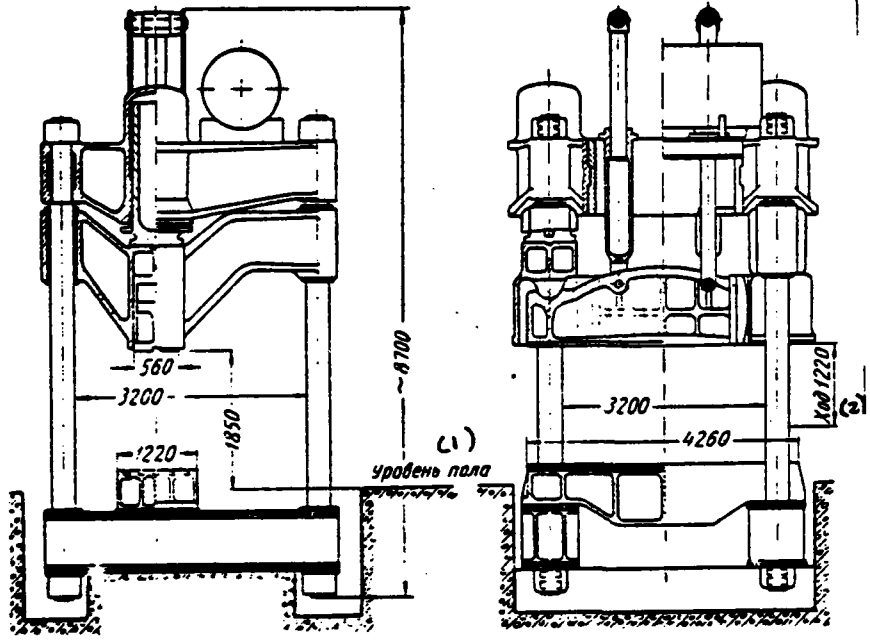

Fig. 75. Hydraulic corner post-type bending press by effort/force 2000 t.

Key: (1). level of floor. (2). Course.

Page 95.

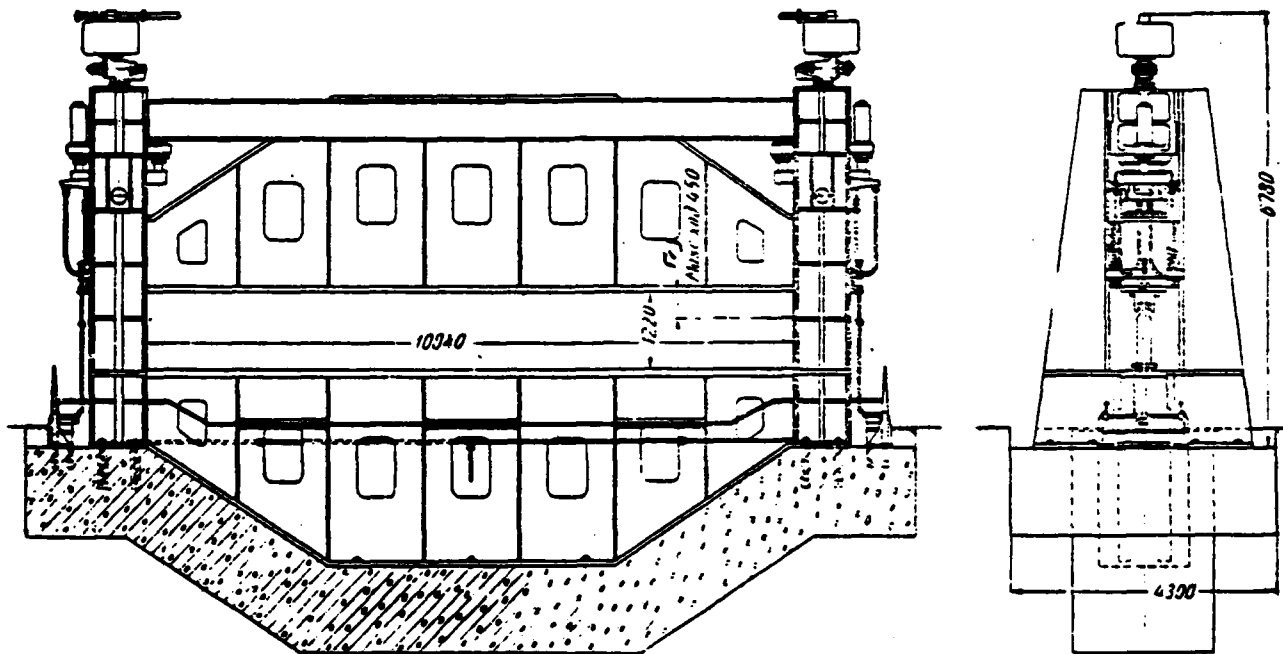

Fig. 76. Hydraulic bending press by effort/force 800 t with the frame mounting.

Key: (1). Max course.

Page 96.

This new method is applied for the hot die forging of finned panels from sheet duralumin (Fig. 74) on the presses by effort/force to 7000 t. The process of stamping with the fraction makes it

possible to quench parts in the die/stamp, for which the formed part is maintained/withstood in the die/stamp to 2 min.

Presses for bending and straightening the thick sheets.

For bending thick sheets of large dimensions to small angles with small radii in the boiler room, ship-building and other branches of machine construction utilize hydraulic presses by effort/force to 15000 t. The presence in them of long and narrow crosshead is the distinctive special feature/peculiarity of such presses, load on which is created by the end presses, connected with lower fixed cross-beam. For the possibility of bending sheet to the different angles the crosshead can be distorted (to be moved under load, being that sloped to the necessary angle).

End presses are fulfilled both with the column (Fig. 75) and with the frame mounting (Fig. 76).

The construction/design of male die/punch for bending of sheets to small angles and radii is shown in Fig. 77.

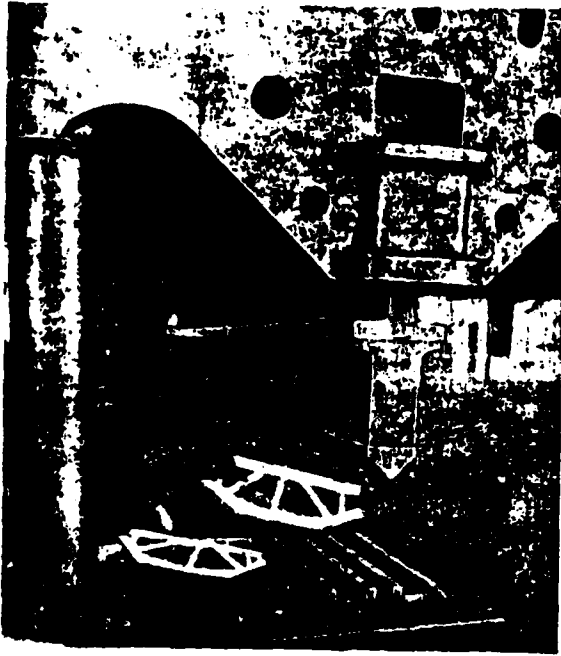

Fig. 77. Design of flexible press punch with a force of 2000 t.

Page 97.

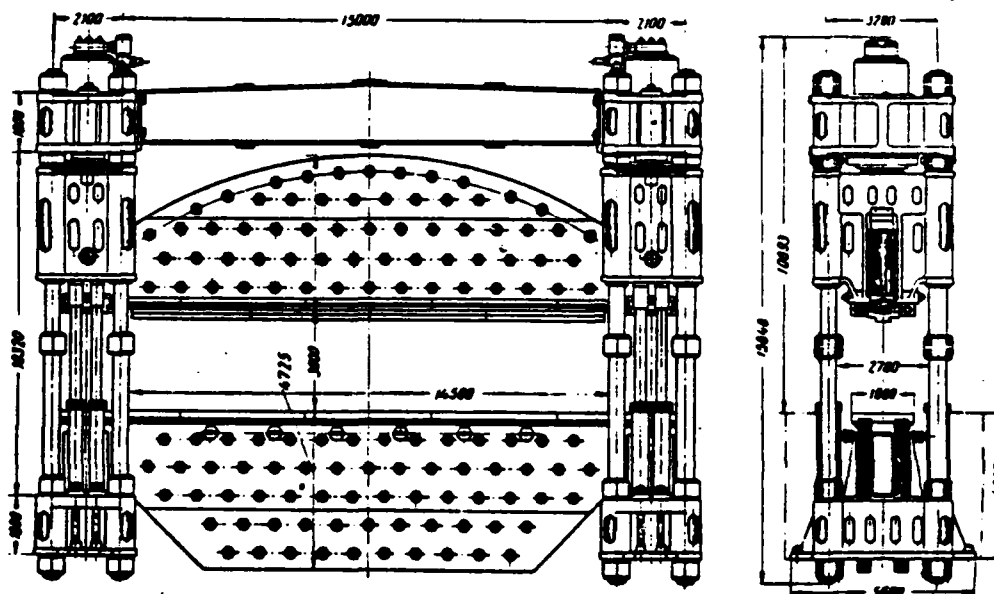

Fig. 78. Hydraulic bending press by effort/force 8000 t
(TsNIITMASH-UZTM).

Page 98.

Bending presses are applied also for bending of the half-rims, which then are welded by the longitudinal seam into the shells (cylinders), which go for manufacturing of steam boilers and vessels for storing of liquids and gases under the high pressure. The most

powerful/thickest press of this type of the construction/design of TsNIITMASH-UZTM develops effort/force 8000 t (Fig. 78) and allows/assumes bending sheets with length to 12000 mm and with the thickness of more than 200 mm. Construction/design consists of two paired between themselves presses, which develop effort/force on 4000 t. The lower cross-beam, arranged/located between the presses, is rigidly connected with the lower plates/slabs of presses. Upper crosshead by its ends is connected with the sliders of presses hinged (Fig. 79), thanks to which the inclination/slope of the crosshead to 4° is allowed/assumed.

For guaranteeing the parallelism of the motion of cross-beam is provided for synchronizer, which consists of eight cylinders (four upper and four lower), connect/joined together on the diagram, shown in Fig. 32. The mobile bending cross-beam of this press is beam of variable/alternating/variable section/cut, made in the form of the bundle with a thickness of 750 mm, from separate steel sheets by the thickness of 50 mm, fastened by tightening fitted bolt. The maximum course of the crosshead is equal to 1600 mm.

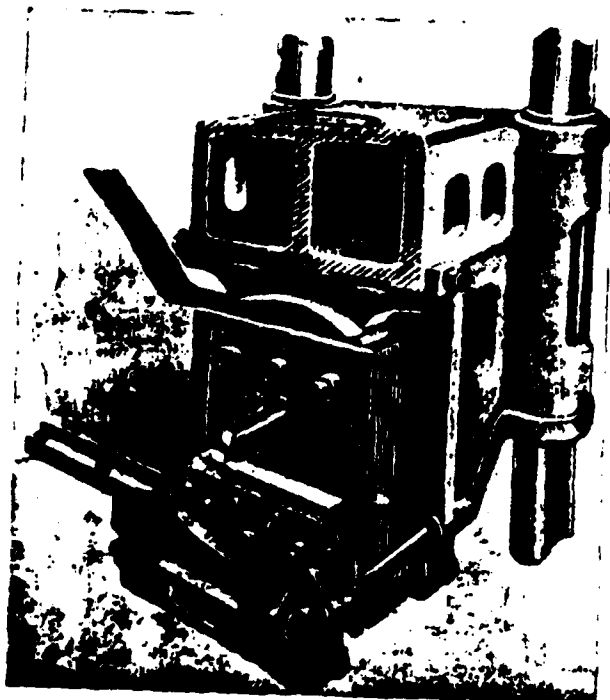

Fig. 79. Connection of cross-beam with the slider of press.

Page 99.

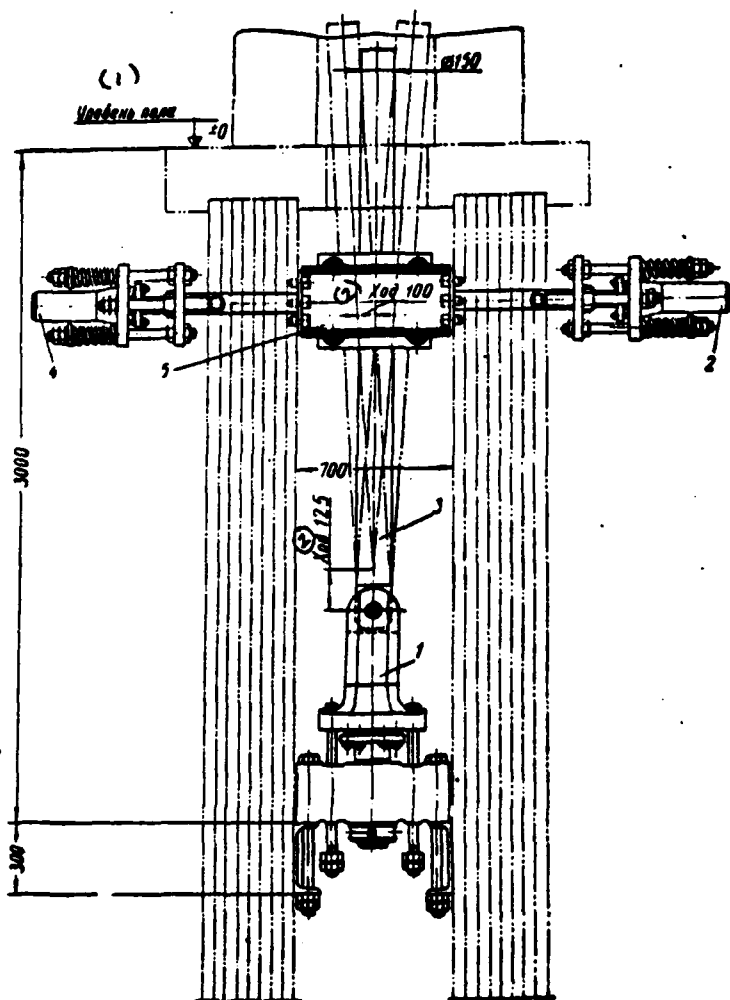

Fig. 80. The pushers of hydraulic bending press by effort/force 8000 t: 1 - cylinder of lift; 2 - cylinder (right) for pushing pusher; 3 - pusher; 4 - cylinder (left) for the vibration of pusher; 5 - slider of pusher.

Key: (1). Floor level. (2). Course.

Page 100.

The lower fixed cross-beam of press in its sizes/dimensions, which are determining its strength, is analogous to the crosshead; structurally/constructionally it is divided into two lacunar bundles, which allows/assumes the arrangement between the bundles of six special pushers (Fig. 80).

These pushers serve for turning of the machined sheets on the die/stamp of press.

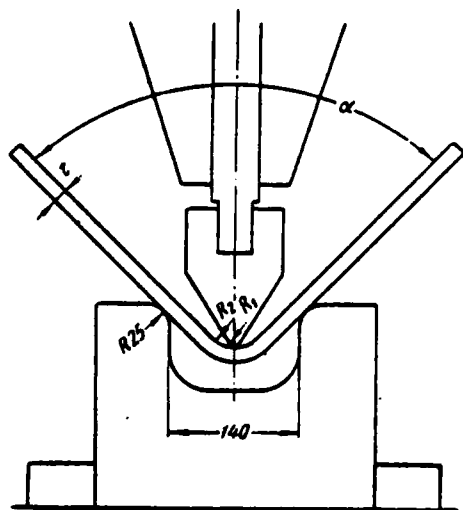

Fig. 81. Diagram of bending.

Table 10.

(1) Потребное усилие пресса в т для гибки 1 лос. и листа			R_1 в мм	(5) Наименьший радиус изгиба R_2 в мм	(6) Наименьшее значение угла α°
(2) Толщина ли- ста t в мм	(3) Характеристика металла				
	(4) $\sigma_b = 32$ кг/мм ²	(4) $\sigma_b = 48$ кг/мм ²			
27	120	180	19	47,5	60
25	105	167,5		44,5	
22	84	126		40,0	
20	70	105		35,5	
19	59,5	89,7		33,0	
18	53	80		31	
16 12,7	41,5 25,6	62,5 40	12,7	28 22	
9,5 6,3	15,1 6,9	22,6 9,9	9,5	14,5 9,5	75

Key: (1). Required effort/force of press in m for bending 1 linear m of sheet. (2). Thickness of sheet t in mm. (3). Characteristic of metal. (4). kgf/mm². (5). Smallest bending radius R_1 in mm. (6). Smallest value of angle α° .

Page 101.

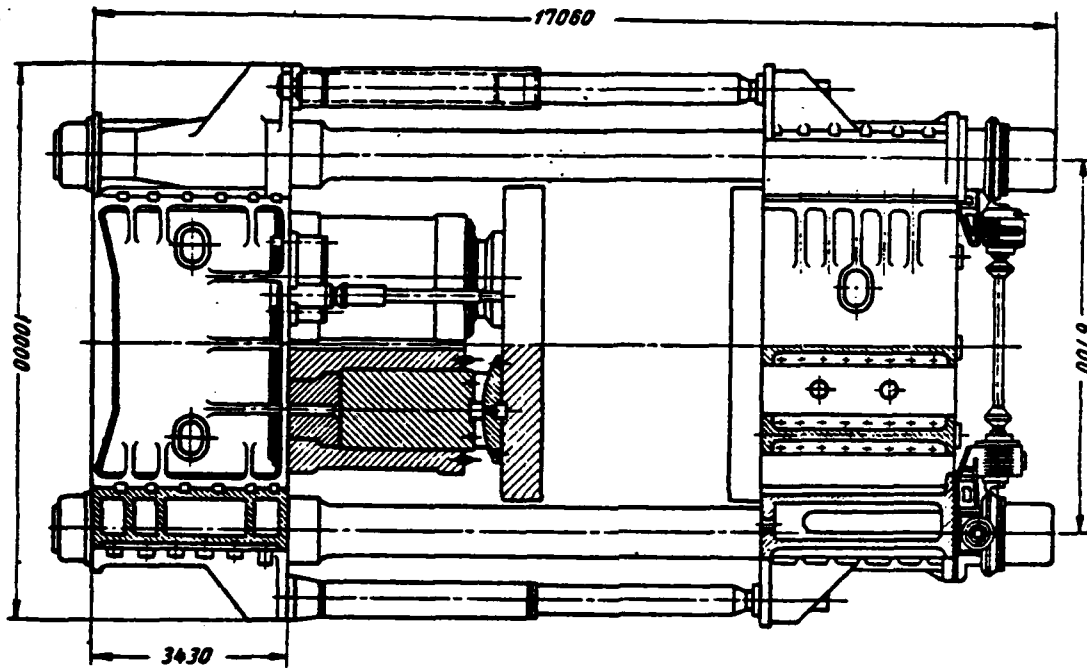

Fig. 82. Straightening -bending press by effort/force 15000 t.

Page 102.

Pusher is the vertical rod, which rests on the hydraulic cylinder, with the aid of which this rod can be advanced upward for lifting the machined sheet. Rod slips in the hinged bushing of the slider, which can be moved to the right and to the left with the aid of two horizontal plungers with the spring return to the neutral position.

By the action of these horizontal plungers in the combination with the vertical cylinder can be achieved/reached the mobility of pusher, sufficient for the turn and the displacement/movement over the die/stamp of the machined sheet. For supplying the sheet into the press and its displacement/movement over the die/stamp during bending of presses it is equipped with special driving/homing horizontal by sliders.

The drive of press is accomplished/realized from the pump-and-battery station with the pressure 200 kg/cm². for the pressure increase in the working cylinders to 400 kg/cm², for which the press is designed, in the hydraulic system multipliers there are.

Press can work at different steps/stages on the effort/force: 2000, 4000, 6000 and 8000 t.

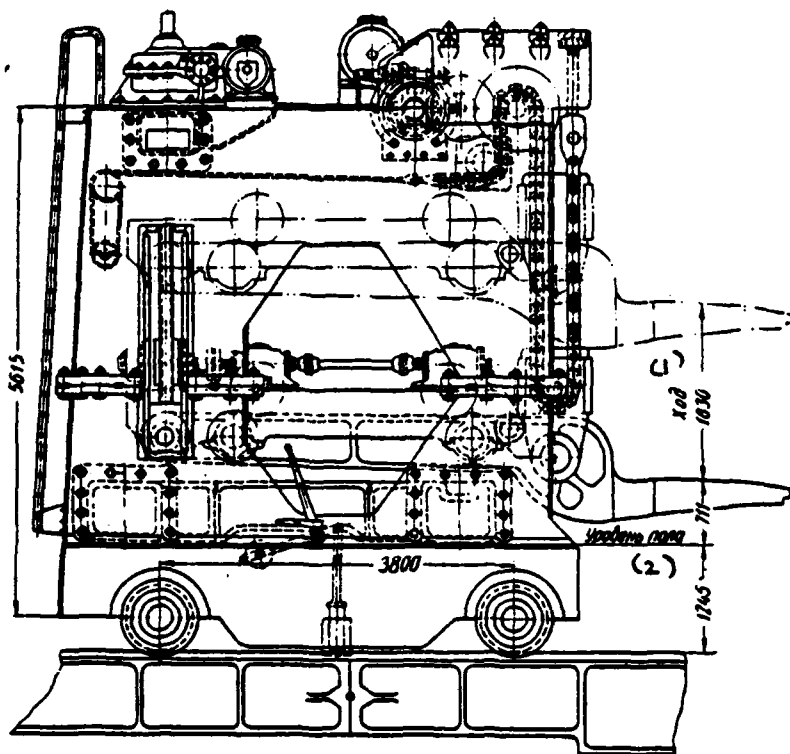

Fig. 83. Manipulator, who operates straightening correct-bending press by effort/force 15000 t. Side view.

Key: (1). Course. (2). Floor level.

Page 103.

The speed of idle and recurrent running of the crosshead of press reaches 100 mm/s and working strokes - to 25 mm/s. The total weight of press is approximately 2500 t.

For determining the required effort/force of press during the cold bending of sheets (Fig. 81) the data, given in Table 10, can be used.

For straightening of thick sheets and small bending under is won acceptance of press with the lower arrangement of working cylinders: The schematic of the most powerful/thickest press of this type is shown by effort/force 15000 t in Fig. 82. Press is given from the group of three-plunger pumps, from which the most powerful/thickest, which develops pressure 450 kg/cm², is given by electric motor of direct current (system engine - generator), which provides continuously variable control of the velocity of the motion of working plungers. Press is serviced by the special manipulator (Fig. 83 and 84) with two cantilever rocker shaft arms for lifting sheet.

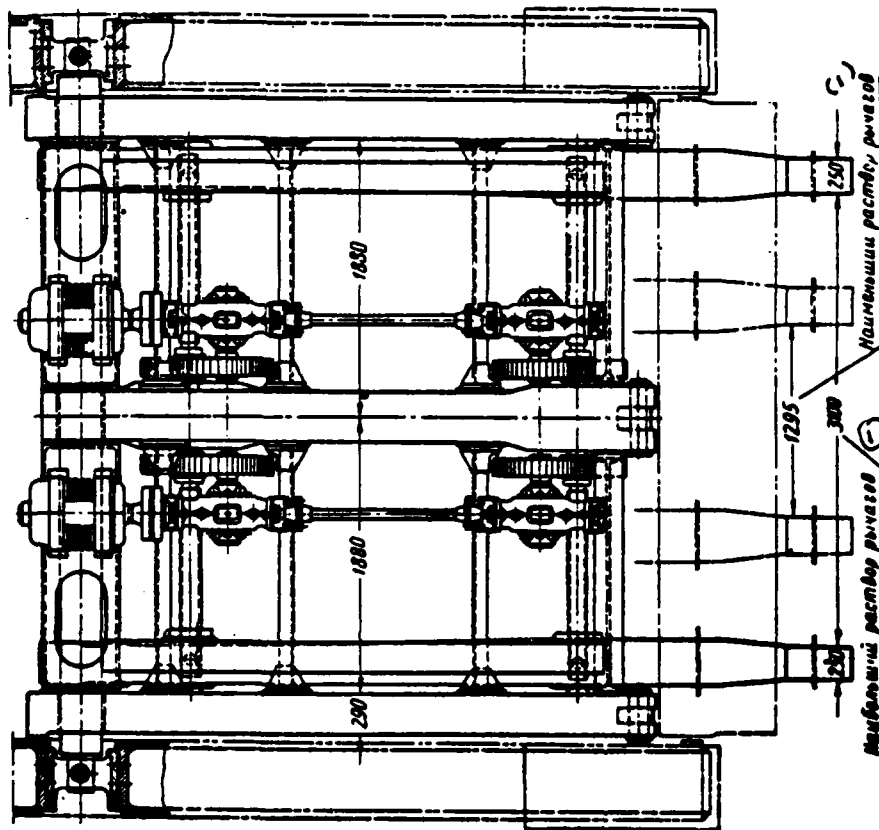

Fig. 84. Manipulator, who operates straightening-bending press by effort/force 15000 t. Plan view.

Key: (1). least opening of levers.

Page 104.

The levers of manipulator have vertical displacement/movement, the

distance between them in the plane is regulated over wide limits. Manipulator is moved on the rails, packed on the floor/sex along the front of press.

straightening-bending presses of smaller powers are constructed also with vertical arrangement of cylinders with their feeding from the plunger pumps working on oil which are mounted on the mounting of press. A similar press is shown by effort/force 4500 t in Fig. 85.

BAR- TUBE PRESSES.

Different profiles/airfoils, rods, wire and ducts/tubes/pipes from the nonferrous metals and their alloys are manufactured with extrusion predominantly on the hydraulic presses.

The schematic diagrams of the manufacture of rods by the method of extrusion are shown in Fig. 86.

By extrusion are obtained profiles/airfoils, etc. mainly from copper, brass with the content of copper 58-70%, from aluminum and its alloys, and also from the aluminum bronze, the tin, lead, etc. At present with the mastery/adoption of the new lubrications, stable at high pressures and temperatures, the method of extrusion is extensively used also for manufacturing of profiles/airfoils and

ducts/tubes/pipes made of steel, heat-resistant and other wrought alloys.

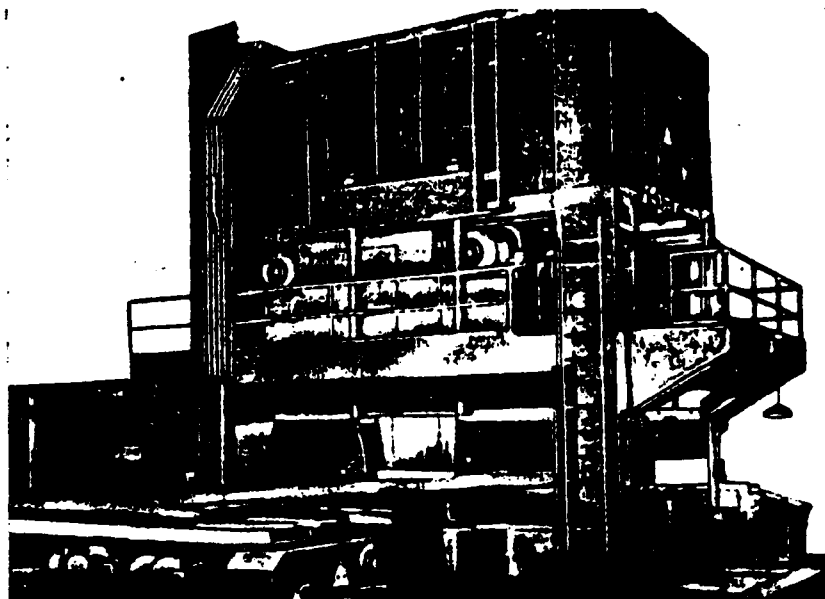

Fig. 85. A correct-bending press by effort/force 4500 t with the drive from the rotational-plunger pumps.

Page 105.

Examples of the profiles/airfoils, obtained by extrusion, are shown in Fig. 87:

In the mass production the rods with the diameter of 6-200 mm, duct/tube/pipe with a diameter of 20-260 mm, equilateral and scalene angles with a width of the flange of 12-100 mm and many other complicated profiles/airfoils are manufactured.

Usually the length of the extruded rods and ducts/tubes/pipes varies from 1 to 5 m. Rods with a diameter of less than 10 mm manufacture in the form of bays with length to 50 m.

Blanks for the subsequent stamping on the hydraulic presses and the hammers also are obtained by extrusion, and in this case rods are manufactured of considerably larger sections/cuts.

For example, on the press with effort/force 18000 t it is possible to extrude blank of the ingot with a diameter of up to 1000 mm; the weight of this ingot from the aluminum alloy is equal to 2700

kg.

Use for stamping the extruded blanks of complicated profile/airfoil makes it possible to obtain considerable metal savings and to lower the labor intensity of the manufacture of parts. Extrusion considerably raises the mechanical properties of metal.

For example, alloy Sp. AX 9-4 in the cast state has $\sigma_s = 30-50$ kgf/mm², and after extrusion σ_s of 50-65 kgf/mm². Alloy JC 59-1 in the cast state has $\sigma_s = 34$ kgf/mm², and after extrusion $\sigma_s = 40$ kgf/mm². By extrusion are obtained the articles of more precise sizes/dimensions than during the rolling.

Tolerance for the articles composes 4-8% of the sizes/dimensions of section/cut.

Speed and ease/lightness of the replacement of instrument make it possible to produce series of the articles of different sizes/dimensions on one and the same press. Because of the high precision/accuracy of the obtained articles, and also the high productivity, the process of the extrusion of articles by relatively small series is sufficiently economical.

There are two methods of the extrusion: straight line and

reverse/inverse. With the direct method (Fig. 86a) the direction of the metal flow coincides with the direction of the motion of the stamp extruding metal, while with the reverse/inverse (Fig. 86b) - metal flow occurs in the opposite direction.

With the reverse/inverse method required effort/force for the extrusion is less than with the straight line, since the extruded blank does not test/experience wall friction of container.

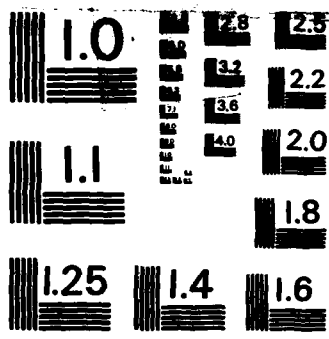

MICROCOPY RESOLUTION TEST CHART
NATIONAL BUREAU OF STANDARDS-1963-A

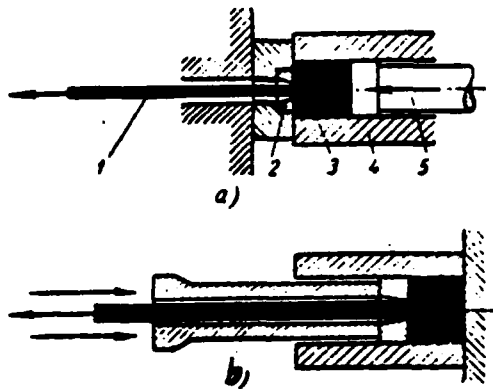

Fig. 86. The schematic diagrams of the manufacture of rods by the method of the extrusion: a) the method of direct extrusion; b) the method of reverse/inverse extrusion; 1 - article; 2 - matrix/die; 3 - ingot; 4 - container; 5 - press die.

Page 106.

However, with the work according to this method the quality of articles is obtained somewhat worse; it to a considerable degree depends on the quality of the surface of ingot, surface layer almost completely is extruded to the surface of article. With the direct method, as a result of the presence of forces of friction, which affect the surface of ingot, the flow of surface layer is retarded and it almost completely remains in press waste.

As a result of the reasons indicated, and also taking into account that press waste with the extrusion according to the direct

method it composes insignificant value and that the work according to this method is simpler, it at present has larger propagation.

Contemporary bar-tube presses are constructed with the efforts/forces to 20000 t. The characteristics of some constructed presses are given in Table 11.

Presses by an effort/force 5000 t and more utilize mainly for obtaining the blanks of round or rectangular cross section, used for the subsequent stamping of parts on the vertical presses, and also for obtaining of finned panels and ducts/tubes/pipes.

Presses with effort/force up to 750 t are usually fulfilled by vertical ones with frame type mounting and are intended mainly for the extrusion/pressing of thin-walled tubes. With the frame A-bedplate of press is easy to carry out precise, without the large deviations from the vertical axis of movement of the slider, which carries press die.



Fig. 87. Examples of the profiles/airfoils, obtained by extrusion.

Page 107.

Table 11. Some characteristics of the constructed bar tube presses.

(1) Параметры	(2) Вертикальные прессы		(3) Горизонтальные прессы						
(4) Усилие, развиваемое прессующим штампом, в т . . .	600	750	1000	1200	1500	2000	2500	3500	4500
(5) Ход прессующего штампа в мм . . .	1015	760	760	760	1650	915	915	2110	2133
(6) Усилие, развиваемое прошивным цилиндром, в т . . .	75	—	—	—	160	—	—	415	—
(7) Ход прошивной иглы в мм . . .	1385	—	—	—	2300	—	—	2135	—
(8) Диаметр контейнера в мм . . .	95—120	76—128	76—152	95—152	152—254	178—254	178—254	205—425	234—412
(9) Число колонн и их диаметры в шт/мм	(10) Двухстоечный	4/228	4/228	4/254	3/305	4/305	4/—	4/406	4/384
(11) Расстояние между центрами колонн в мм . . .	(12) Между стойками 1170	1067×965	1067×965	1194×762	—	1475× ×1195	1475× ×1195	2337× ×1676	2184× ×1981
(13) Рабочее давление в кг/см ² . . .	220	200	200	200	200	200	200	200	316
(14) Расход жидкости высокого давления на 1 цикла в л . . .	—	303	398	530	—	946	—	1900	900
(15) Производительность (ориентировочно) в шт/час:									
(16) врутков . . .	40—45	50	50	40	38	35	35	30	—
(17) труб . . .	40—45	35	35	—	45	—	—	—	—
(18) Высота прессы в мм	7160	2745	2745	2050	3810	3965	—	5185	4520
(19) Габариты прессы в плане в мм . . .	3440× ×3600	21 336×3048	21 336×3048	22 530×3355	33 550×6500	24 385× ×3 960	—	52 120× ×12 190	23 968× ×3 775
(20) Общий вес прессы в т . . .	83	55	56	82	—	100	—	500	385

Key: (1). Parameters. (2). Vertical presses. (3). Horizontal presses. (4). Effort/force, developed with the pressing stamp, in t. (5). the course of the pressing stamp in mm. (6). Effort/force, developed with piercing cylinder, in t. (7). Course of piercing needle in mm. (8). Diameter of container in mm. (9). Number of columns and their diameters in pcs/mm. (10). Two-strut. (11). Distance between centers

of columns in mm. (12). Between struts 1170. (13). Operating pressure in kg/cm². (14). Fluid flow rate of high-pressure on 1 cycle in l. (15). Productivity (tentatively) in pcs/h. (16). rods. (17). ducts/tubes/pipes. (18). Height/altitude of press in mm. (19). Dimensions of press in the plan/layout in mm. (20). Total weight of press in t.

Page 108
(1) Presses no AA

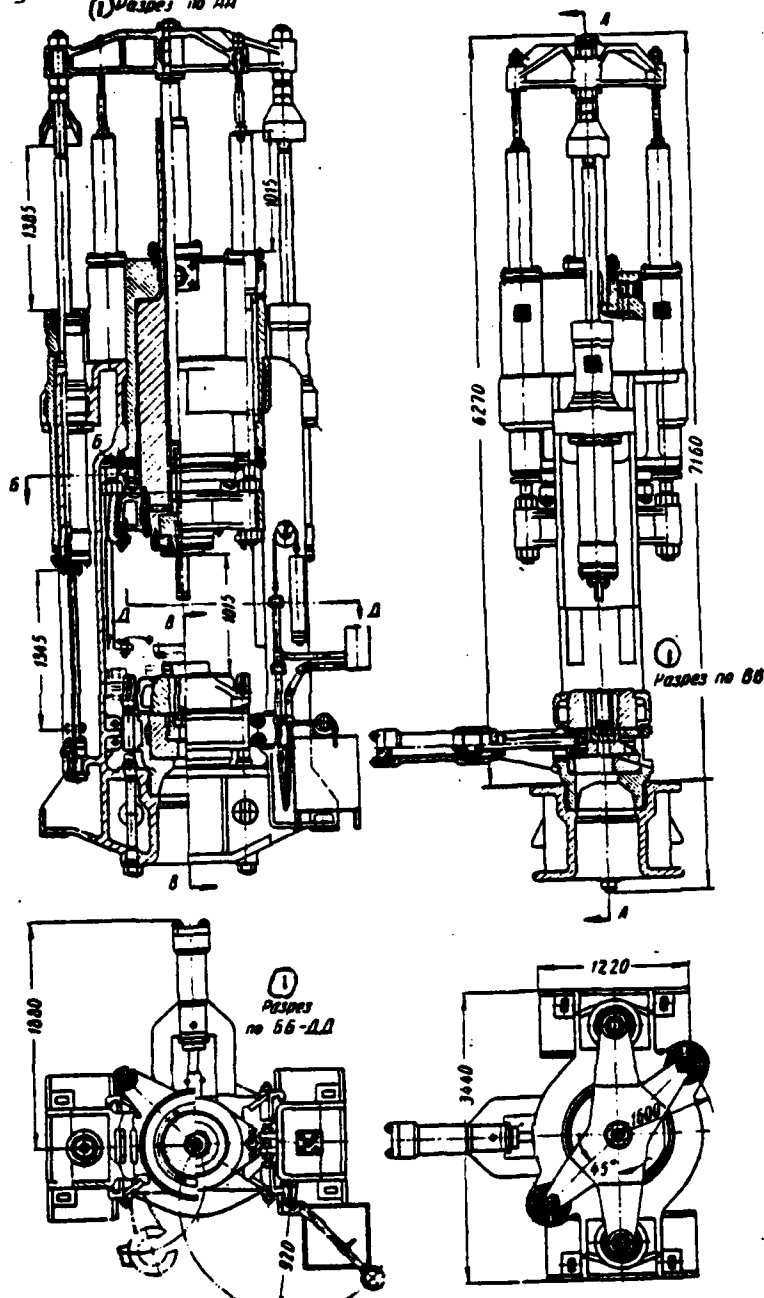

Fig. 88. Vertical bar-tube press with effort/force 600 t.

Key: (1). Section/cut on.

Page 109.

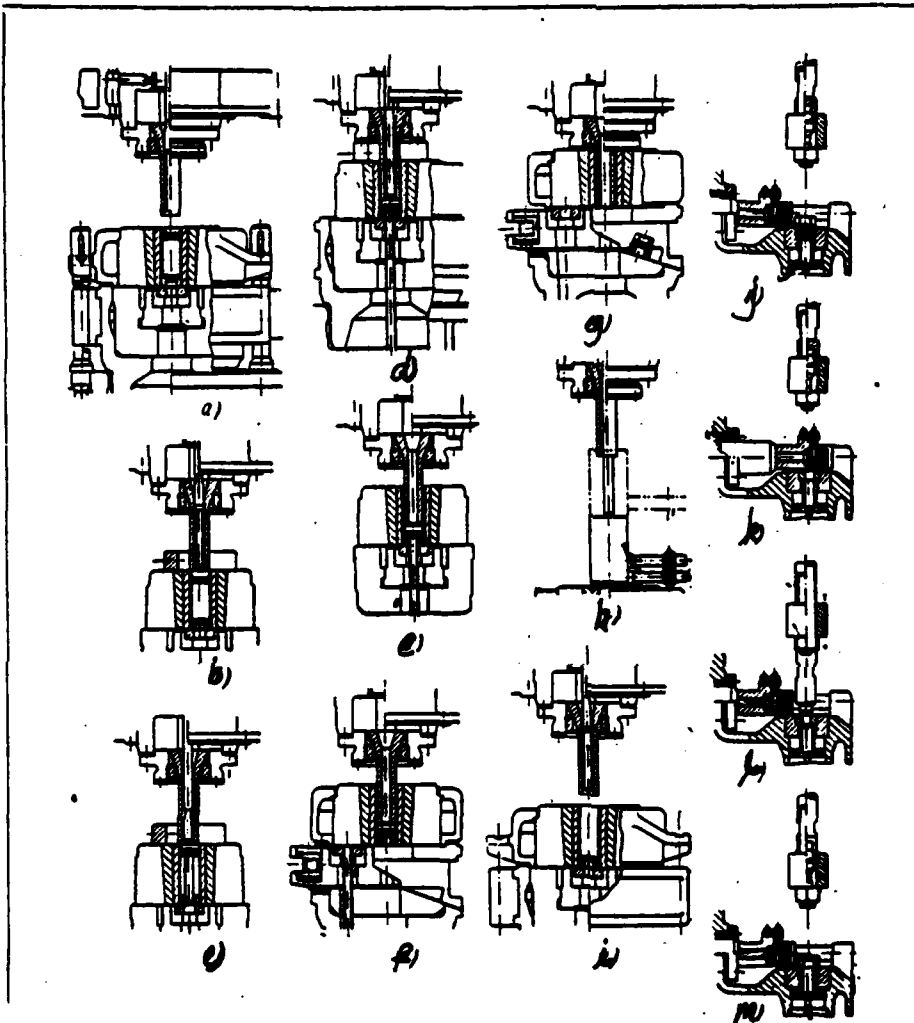

Fig. 89. Sequence of operations with the extrusion of ducts/tubes/pipes on the press by effort/force 600 t: a) ingot is loaded into container; from above the ingot is laid the pressing disk; b) - is conducted/supplied base plate; the pressing stamp is omitted to the pressing disk, into master cylinder on the short period the pressure is given, broaching needle is conducted/supplied

to the ingot; c) stamp is raised a little in order to make possible to metal leak upward with the piercing; is broached ingot; d) the extrusion of duct/tube/pipe; e) piercing needle is diverted upward; main slider with the press die is raised in order to free base plate from the pressure; base plate is diverted; f) duct/tube/pipe is cut off by the shearing matrix/die; g) press die makes downstroke and it ejects matrix/die; h) press die is abstracted/removed to the upper position; piercing needle it lowers, it is fed cooling container, it is established/installed along the axis of press it is built up for cooling the needle; i) is abstracted/removed the cooling container; needle is abstracted/removed to the initial position; it is fed block with the shearing matrix/die it is established/installed along the axis of press; into the pressing container the matrix/die is laid; press is ready for the load of the following ingot; j) the matrix/die also of press waste give self up to the special installation for the overflow press waste; k) is removed the pressing disk; l) is ejected press waste afterward cutting; m) is ejected matrix/die.

Page 110.

The general view of vertical press with effort/force 600 t is shown in Fig. 88. Sequence of operations with the extrusion on this press of duct/tube/pipe is given in Fig. 89.

The sequence of the extrusion of rod on the horizontal press the direct method is shown in Fig. 90, and on the reverse/inverse - in Fig. 91.

Bar-tube presses are frequently constructed by those combined, i.e., with the possibility of work on them both on the straight line and according to the reverse/inverse method. In this case the container is fulfilled by mobile, while in the presses, intended only for the extrusion according to the direct method, container-holder is rigidly connected with bolts with the front/leading plate/slab.

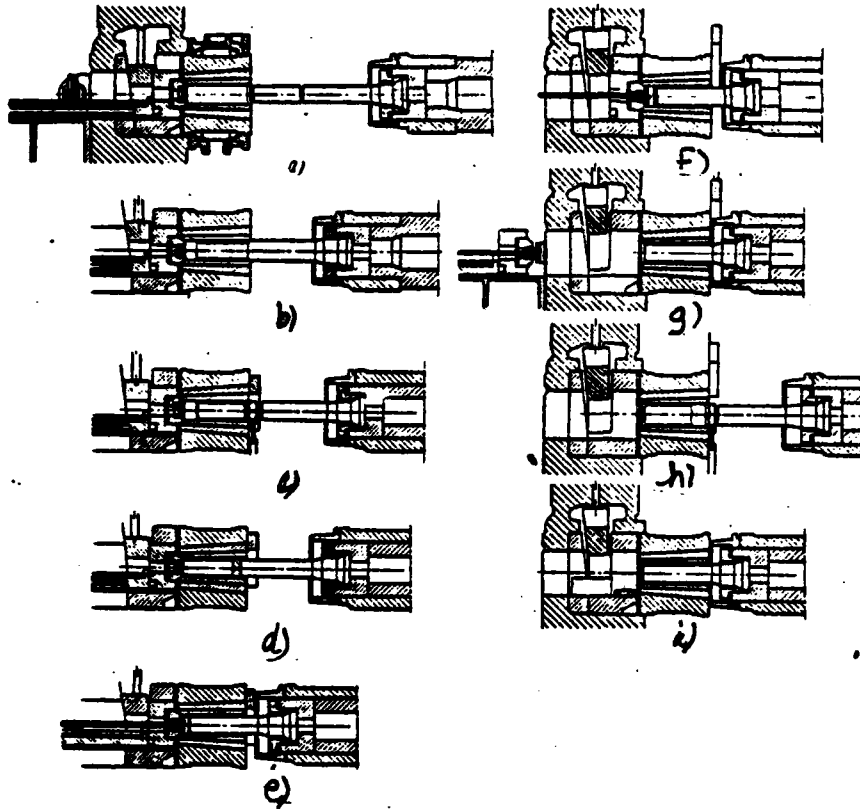

Fig. 90. Sequence of operations with the extrusion of rod according to the direct method: a) the supply of ingot into the press; b) the supply of ingot into the container; c) the supply of dummy block into the press; d) the supply of dummy block into the container; e) extrusion; f) the branch/removal of gate/shutter and base plate; g) the knockout of outer die; cut/section press waste and the branch/removal of rod; h) the supply of washer for the overflow of jacket; i) the overflow of jacket.

Page 111.

Contemporary bar press consists of the following basic assemblies and mechanisms (without including pumping station and control): the mounting of press, the drive of the pressing stamp - working and pull-backs, container, gate/shutter with the cylinder for his lift, the plate/slab (frequently called outer die), in which the matrix/die, shear press or circular saws, branch/drain table with hydraulic drive, connected with the outer die, mechanisms for supplying of ingot and dummy block into the press is established/installed.

In the presses, intended for manufacturing not only the rods, but also ducts/tubes/pipes, is additionally a mechanism for the piercing of ingot and holding of piercing needle with the extrusion of duct/tube/pipe. Vertical bar-tube presses frequently are constructed without the mechanism of piercing. Needle for the piercing in this case rigidly is connected with press die.

The schematic of bar-tube press is shown in Fig. 92a of operation of the extrusion of duct/tube/pipe on it - in Fig. 93.

One of the distinctive special features/peculiarities of horizontal press, to a considerable degree which is determining its

construction/design, is the method of the load of blank into the container. The schematic diagrams of the existing methods of load are shown in Fig. 94. The supply of blank with the aid of the hydraulic elevator into the gap/interval between the press die and the container (Fig. 94a) is the simplest method of load; however, with this method of the load of blank the construction/design of press is lengthened.

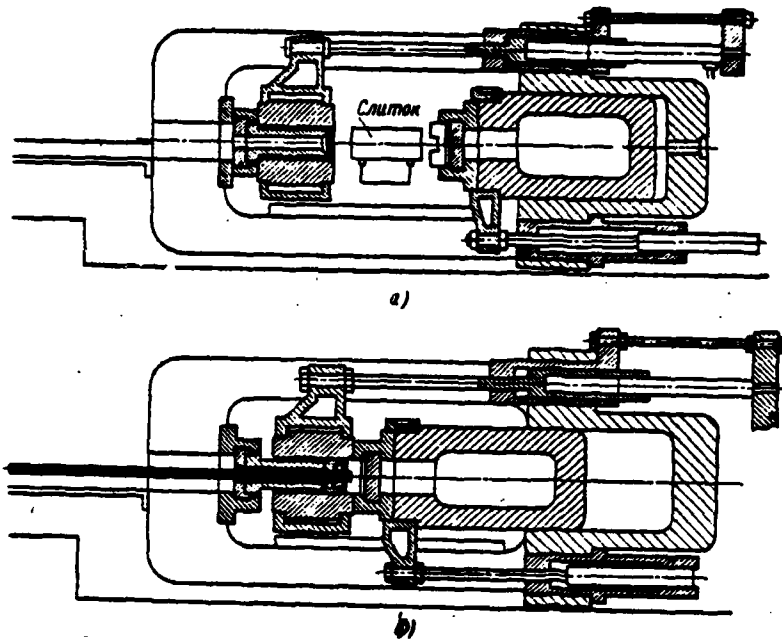

Fig. 91. Sequence of operations with the extrusion of rod according to the reverse/inverse method: a) the supply of ingot into the press; b) extrusion.

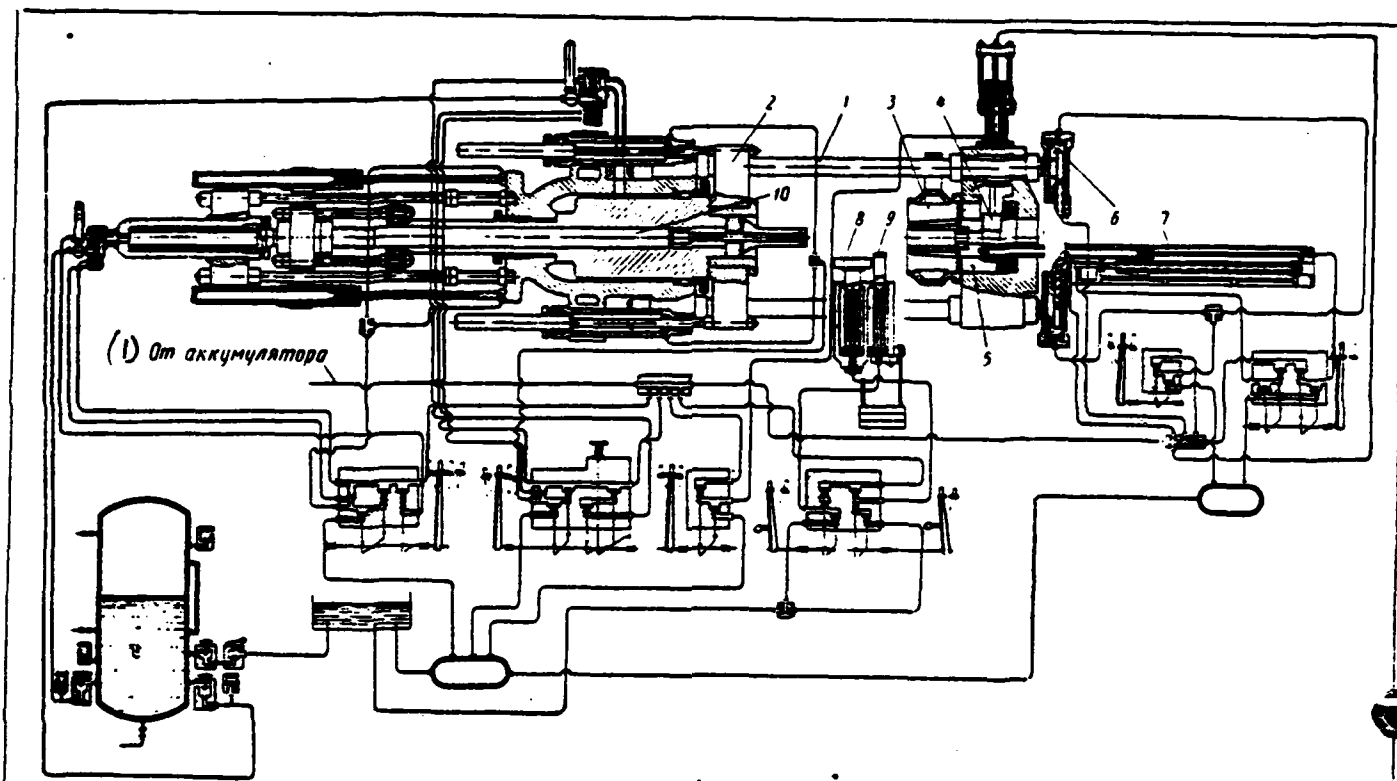

Fig. 92. The schematic of bar-tube press (extrusion according to the direct method): 1 - mounting of press; 2 - drive of stamp (working and pull-backs); 3 - container; 4 - gate/shutter with the cylinder for its lift; 5 - outer die; 6 - shear press; 7 - branch/drain table; 8 - mechanism for supplying the ingot; 9 - mechanism for supplying the dummy block; 10 - mechanism for the piercing of ingot.

Key: (1). From the storage battery/accumulator.

In the presses of relatively low powers with the effort/force 750-1500 t for the load of blanks the lift of stamp with the aid of the hydraulic or pneumatic cylinder (Fig. 94b) is accomplished/realized. In the freed gap/interval between the stamp and the container the blank is supplied and by hand it is serviced into the container.

The method of load, shown in Fig. 94c, is more advanced. Using this method the container is moved to the stamp, freeing the place for the blank, which is placed between the press die and the matrix/die.

In some presses the load of blanks is produced directly from the furnace into the container (Fig. 94d) advanced from the press. This method of load also the foreshortened length of press; however, in this case container does not have stiffening joint with the mounting.

Horizontal presses are constructed by three- and four-roll ones. One of the plates/slabs is not fastened to the foundation so that it could be moved during the strain of columns during the work of press, and also with a change in their temperature. The position of the height/altitude of front/leading plate/slab, on which the container

rests, for obtaining the axial alignment between the press die and the container is regulated by supporting bolts or wedges.

In the old constructions/designs working pressure cylinder (drive of the pressing stamp) was cast together with the plate/slab and presses, as a rule, were constructed single-cylinder.

In the contemporary constructions/designs the plate/slab and cylinder are fulfilled separately, in this case working cylinders are manufactured usually from the forgings.

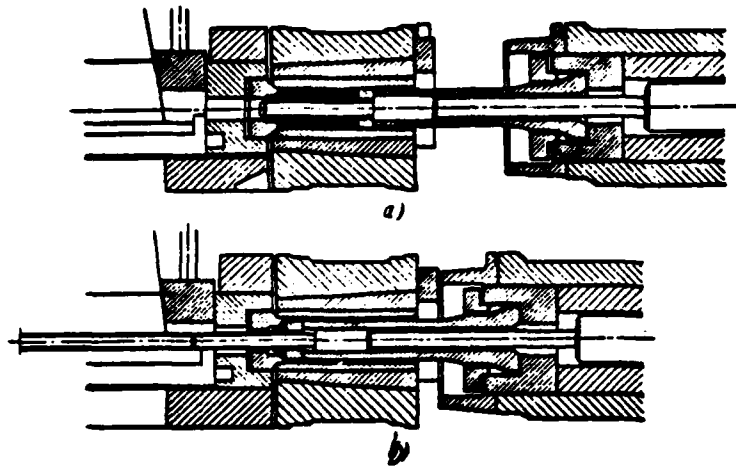

Fig. 93. Operations of the piercing of ingot (a) and extrusion (b) of duct/tube/pipe on the horizontal press.

Page 114.

Powerful/thick presses are fulfilled with several cylinders, which gives the possibility to utilize a press at different steps/stages on the effort/force.

For example, press by effort/force 18000 t, shown in Fig. 95, has five working cylinders by effort/force each on 3600 t. Pitch cylinder in this press, during the manufacture on it of ducts/tubes/pipes, fulfills the functions of piercing.

The container of the press, in which the extrusion/pressing hot

ingot occurs, is fulfilled with the bushing, seated into it on the shrink fit.

So that during the extrusion cooling ingot would not occur, container is preheated: its temperature at the work is maintained approximately to the equal temperature of the extruded ingot, for example for aluminum alloys of 380-450°.

The heating of container in the old constructions/designs is accomplished/realized by gas, and in the contemporary ones - in an ohmic manner.

Container and its bushing work with the large stresses/voltages and at high temperatures, and therefore they are manufactured with forged ones from alloy steels of the following exemplary/approximate chemical composition (in %):

	(1) Контейнер	(2) Втулка
(3) Углерод	0,35—0,40	0,3—0,4
(4) Марганец	0,5—0,8	0,6
(5) Кремний	—	1—1,2
(6) Хром	0,5—0,8	0,425—0,55
(7) Никель	1,5—2	—
(8) Молибден	0,3—0,4	1,25—1,75
(9) Ванадий	—	0,25
(10) Вольфрам	—	1,0—1,5

Key: (1). Container. (2). Bushing. (3). Carbon. (4). Manganese. (5). Silicon. (6). Chromium. (7). Nickel. (8). Molybdenum. (9). Vanadium. (10). Tungsten.

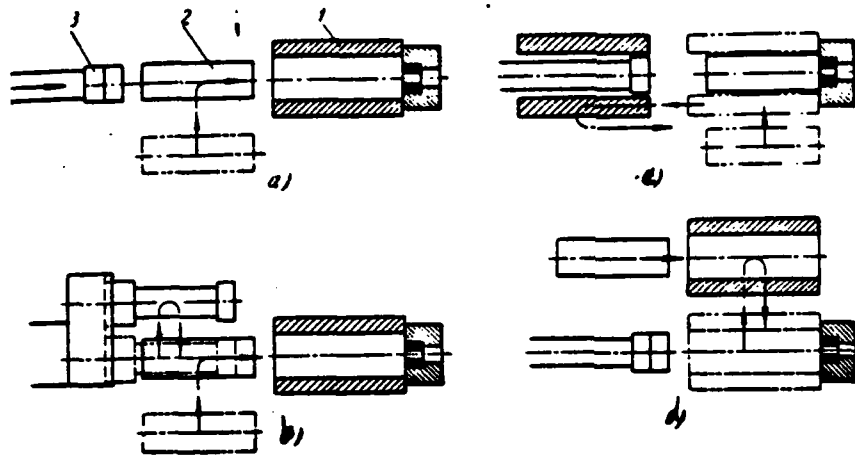

Fig. 94. The schematic diagrams of the load of ingot into the container: a) the supply of ingot into the gap/interval between the press die and the container; b) the lift of press die on the slider; c) the approach of container to the ingot; d) the advancement of container from the press; 1 - container; 2 - ingot; 3 - press die.

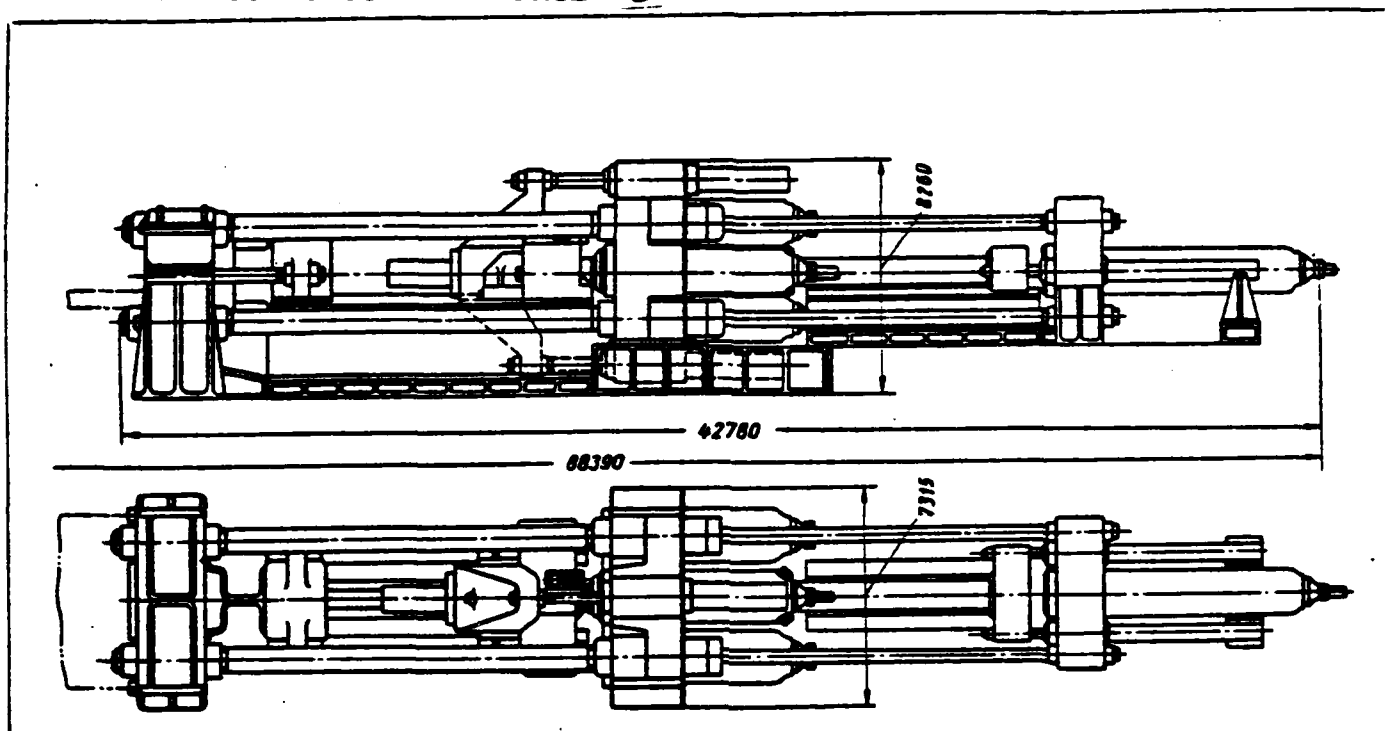

Fig. 95. The general view of bar-tube press with effort/force 18000 t.

Page 117.

Container is established/installed in the dismountable/release container holder, which consists of the steel castings and cover/cap.

The axial displacement of container in the container holder is prevented/warned by the circular step, available at the ends of the container, which enters into the appropriate borings in container holder. The rotation of container is prevented/warned by key. In such a case, when container is moved, container holder is fulfilled with

those adjusted, usually tapered ones, guides.

On the front/leading cross-beam of press are installed the gate/shutter and outer die for the branch/removal of matrix/die with the extruded rod or the duct/tube/pipe to the saw or the shears for the department/separation press waste.

The carrier ring of gate/shutter is installed in the center of cross-beam, for which in it axial boring is done. The lift of gate/shutter is accomplished/realized by the hydraulic cylinders, installed on the cross-beam. Dropping gate/shutter usually occurs under its dead weight.

The outer die, in which the matrix/die is established/installed, transfers the effort of the extrusion through the gate/shutter and carrier ring for front/leading cross-beam. Outer die rigidly is connected with the branch/drain table, which is given from the hydraulic cylinder through the pair of racks and the gear.

Outer die, carrier ring and gate/shutter test/experience high specific pressures and therefore they are manufactured forged from alloy steel.

For the department/separation press waste from the rods or the

thick-walled ducts/tubes/pipes applies shears with hydraulic drive.

The construction/design of shears, established/installed in press by effort/force 3500 t, it is shown in Fig. 96.

Department/separation press waste from the thin-walled tubes is accomplished/realized by rocking circular saws (diameter of disk ~800 mm). The supply of saw to the article, supply during cutting and branch/removal of saw are produced by hand.

The supply of ingot from the furnace to the press usually is accomplished/realized with the aid of the rotary arm, on the guides by which the slider with the mechanism attached on it of the clamp of ingot is moved. The clamp of ingot, the rotation of arm from the furnace to the press and the displacement of slider with the pressed ingot are most frequently accomplished/realized by pneumatic cylinders. For lifting of ingot and dummy block to their coincidence with the axis/axle of container are applied the hydraulic elevators.

The transmission of dummy block from the shears or the saw to the press in the majority of the cases is accomplished/realized on the monorail with the aid of the mobile carriage, from which self-grip tongs are suspended/hung. the displacement of carriage with the tongs is produced by hand.

The majorities of the constructed bar-tube presses are driven from pump-and-battery stations.

However this drive for these presses it is not possible to recognize as advisable on following reasons: with the extrusion of rods the effort/force on the course of working plunger falls, and for maintaining the constant velocity of extrusion/pressing the flow of the working fluid, which enters the cylinder, is necessary to throttle, which connected with the large energy losses causes the rapid wear of controls.

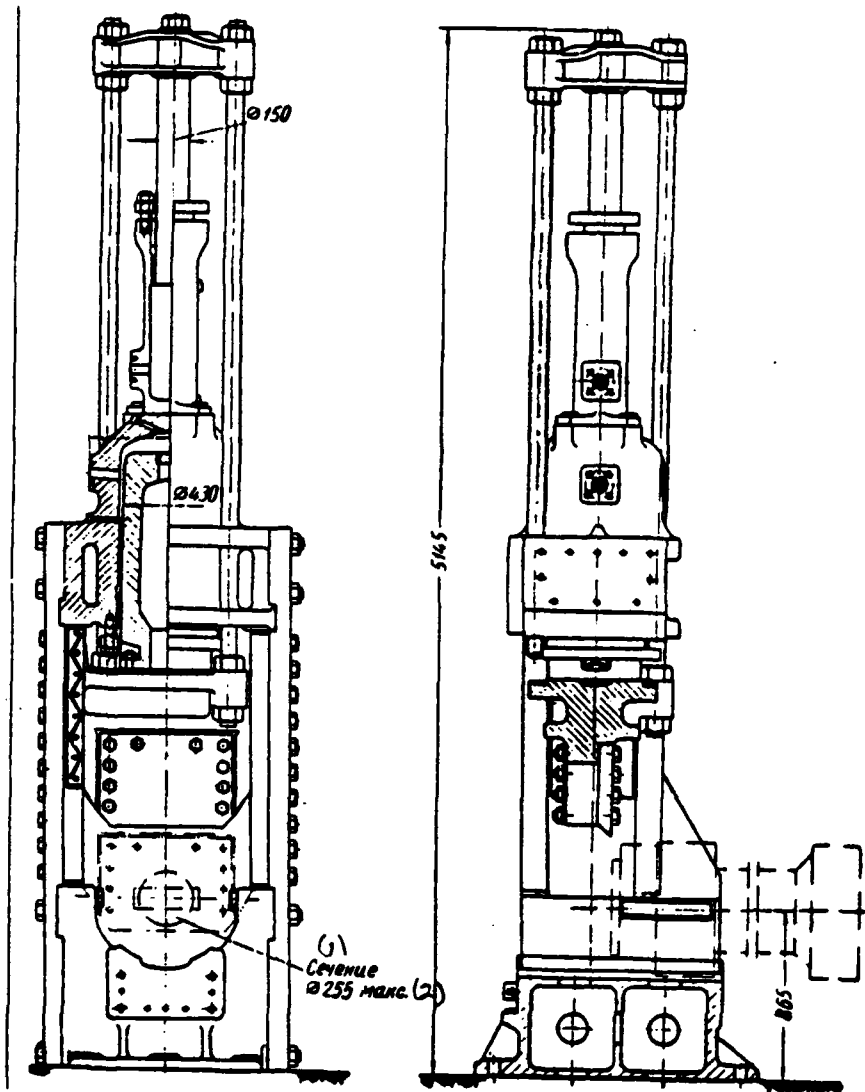

Fig. 96. Shears, established/installed in press by effort/force 3500 t.

Key: (1). Section/cut. (2). max.

Each alloy has its optimum speed of extrusion, moreover the latter oscillates over a wide range. To accurately establish/install the necessary speed of extrusion with the aid of the choke/throttle is difficult, since the effort/force on piston stroke continuously changes.

Usually in the shops they set to several bar-tube presses of different power.

For the extrusion of rod relatively long time is required. Pressure in the forcing line of shop with the feeding of presses from the pump-and-battery station is set to pressure in the press, which works with the minimum load on the effort/force, in consequence of which the productivity of remaining presses descends and frequently the separate presses as a result of the insufficient pressure in the system stop. Therefore individual batteryless pumping drive is the most rational drive of bar-tube presses. Contemporary bar-tube presses, thus far also relatively low powers (by effort/force to 3000 t), they are made with this drive.

The basic initial technological parameters for designing bar-tube press are: the maximum effort/force, required for the

extrusion of the prescribed/assigned article; the degree of the reduction of ingot and the discharge velocity of metal from the matrix/die.

The required effort/force of extrusion can be determined according to the formulas of S. I. Gubkin, which obtained the widest use, or tentatively on the basis of the required specific pressures with the extrusion.

With the extrusion of profiles/airfoils from duralumin the specific pressures, depending on the form of profile/airfoil, oscillate from 25 to 70 kgf/mm².

The nominal effort/force of press can be determined according to the formula

$$P = \frac{P'}{k},$$

where $k=0.75-0.85$ for the presses with the drive from the pump-and-battery station; $k=0.9-0.95$ for the presses with the batteryless drive;

P' - required effort/force for the extrusion.

The degree of reduction is defined as the ratio of a difference in the areas of container and sum of the areas of all holes of

matrix/die ($F_0 - \sum F_1$) to the area of container (F_0):

$$\gamma = \frac{F_0 - \sum F_1}{F_0} \cdot 100\% = \frac{\lambda - 1}{\lambda} \cdot 100\%.$$

Usually extrusion is conducted with the degree of reduction, equal to 90-75%.

The discharge velocity adopted through the matrix/die depends on the brand/mark of the extruded metal or alloy and does not exceed 20 cm/s.

Page 119.

By the prescribed/assigned discharge velocity, the speed of press die (speed of plungers of working cylinders) is determined on the relationship/ratio

$$v \sum F_1 = v' F_0,$$

where v - discharge velocity;

v' - speed of plunger;

$$v' = \frac{1}{\lambda} \cdot v = \left(1 - \frac{1}{100}\right) v$$

Usually the speed of working plungers for the small presses is received as 50 mm/s, but for the powerful/thick presses - not more than 25 mm/s.

PIERCING AND BROACHING PRESSES.

Many holloware with the relatively larger wall thicknesses are manufactured on the hydraulic presses with the method of the piercing of hot blank and its subsequent broach through the series/row of matrices/dies.

Such articles include different hollow cylindrical housings, bottles for storing of gases or liquids under the high pressure, etc. The manufacture of these articles is produced from the measured rolled blank or the ingot. Rolled dummies on the marking usually notch by gas burners and then they break in the cold or heated state on press-cold shorts.

The piercing of blanks is produced in the adjustable on the bolster container with the broach, attached on the crosshead of press.

Blank selects square section/cut. Square blank is cheaper than the circular; for its piercing the effort is required less, durability of instrument with this above.

Square blank with the piercing in the container of round cross section is centered well; metal is crushed to the sides and it only

insignificantly flows upward along the walls of container and the broach and, thus, to a lesser degree it wears them. The pierced and not had time to cool off blank they transfer on the drawn-out the press, in which, put on to the mount/mandrel by the consecutive broach through the series/row of the decreased according to the bore rings (matrices/dies), it is lengthened and is obtained thinning walls. In some articles, such as for instance, bottles, the field of broach the open end begins to forge. For accomplishing this operation special forging presses are applied. The sections, comprised of the shaped rollers (Fig. 97), frequently instead of the rings are applied.

With the broach through the rollers is required the smaller effort: durability of the rollers higher than durability of rings.

However, the manufacture of roller sections considerably more complicated and ring with the rollers has considerably large overall dimensions in comparison with the plate/slab, in which the matrix/die is established/installed, which increases the dimension of press and complicates its manufacture.

Page 120.

Therefore presses with the roller sections it is expedient to

construct for the use/application in the mass production, when it is possible to completely charge press by one article.

Piercing presses.

Piercing presses they usually construct by vertical four-roll ones and equip with extensible table and two knockouts, of which one is placed in center of press (central), and another on the side, in the center of the table, when the latter is located in the end advanced position (side).

The powerful/thick presses, relied on intense work, are made with the upper extensible plate/slab, on which they fasten two broaches, that work alternately: at that time when by one it is produced piercing, another - is cooled. For the intense cooling are applied the small tanks with oil, which fasten usually on the mounting of press. The broach advanced from the press is dipped in oil with the course of the crosshead down.

The presence of extensible table in the press provides convenience in the work on it.

The load of heavy blanks into the container, and also the knockout of the pierced blank of the container is produced with the

table advanced from the press. With the work with the advancement of table entire course of the crosshead can be almost completely used for the piercing. Central knockout is made with the smaller course in comparison with the course of side and it they use when are broached the small blanks, for load and unloading which the advancements of table is not required.

Central knockout can be used for the removal/output of the pierced blank from the broach when container is fastened on the crosshead, and broach - on the bolster. The process of piercing in this case is schematically shown in Fig. 98.

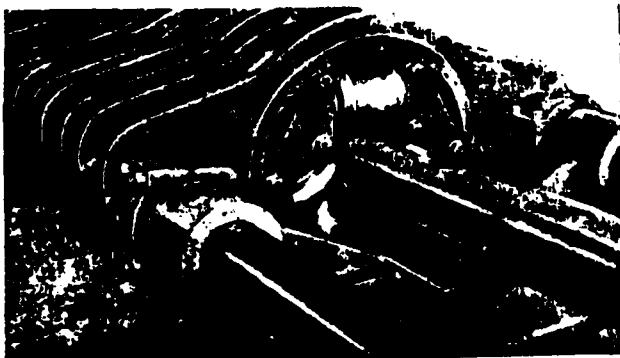

Fig. 97. the broach of the blank through the shaped rollers.

Page 121.

The installation of container on the crosshead of press, and broach - on the table has an advantage in the fact that in this case the container for each course is descaled and, furthermore, with the aid of the plate/slab of extractor the container is centered well with the broach and, thus, minimum wall thickness variation in the broached blank is reached. However, this arrangement of instrument can be used for the blanks small along the length, since in this case are utilized less than $1/3$ courses of the crosshead. The course of the crosshead of press with the extensible table is selected more than the depth of piercing, accomplished on the press, to 30-40%. Values of the course of crosshead take the maximum clearance between the crosshead and the bolster as equal to 2.2-2.5.

Effort/force for the piercing usually is calculated according to the formula

$$P = 0,001 \frac{\pi d^3}{4} \sigma t,$$

where d - diameter of the broached hole in mm;

σ - specific resistance with the piercing, which for steels with a tensile strength of up to $\sigma_s = 80$ kgf/mm² is received equal to 30-40 kgf/mm².

The effort/force, developed with press with the piercing on the larger part of the working stroke, remains practical constant and only at the end of the course somewhat grows/rises.

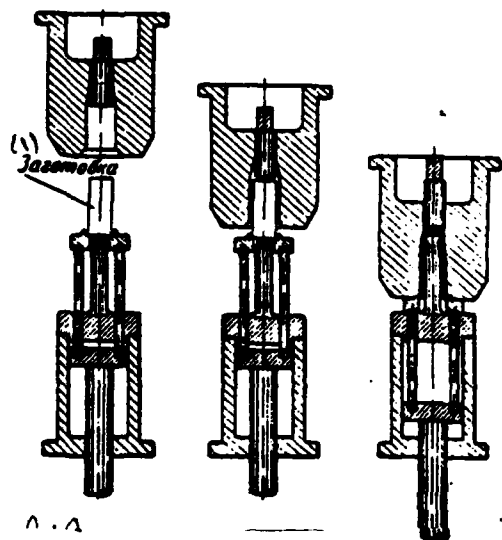

Fig. 98. Piercing in the container, fastened/strengthened to the slider of press.

Key: (1). Blank.

Table 12. Exemplary/approximate relationships/ratios of the basic parameters of broaching presses.

(1) Усилия, развиваемое прессом, в т	(2) Ход подвижной по- перечины в мм	(3) Максимальный прос- вет между подвиж- ной поперечной и столом в мм	(4) Расстояние между ко- лонн в свету в мм
200	750	1650	700×700
300	900	2000	750×750
500	1250	2700	875×875
700	1400	3100	950×950
1000	1500	3400	1000×1000
1500	1800	3900	1500×1500

Key: (1). Effort/force, developed with press, in t. (2). Course of the crosshead in mm. (3). Maximum clearance between mobile crosshead and table in mm. (4). Distances between columns in the light/world in mm.

Page 122.

Piercing on the presses is accomplished/realized with a speed of up to 350 mm/s. Piercing presses usually are given from pump-and-battery station.

The exemplary/approximate relationships/ratios between the effort/force, developed with press, and its other parameters in the constructed presses are given in Table 12.

Broaching presses.

Broaching presses are constructed horizontal with two and less frequently three columns (Fig. 99). Depending on the developed effort/force of press they make with one or several working cylinders. Working cylinders are installed in the base plate, connected with columns with the plates/slabs, in which the rings for the broach (matrix/die) are established/installed. Usually one of the plates/slabs has constant/invariable position, while other plates/slabs can be set in different positions along column of press. The position of these plates/slabs is fixed/recorded with the split clamps, slipped over columns.

For the fixation of plates/slabs also are applied the seating shoes with the slots/grooves, in which the teeth, made on the plates/slabs, go. Fixation of plates/slabs in the slots/grooves of the shoes, put on to the columns, is more advisable, since in this case to more easily accomplish/realize rearrangement of plates/slabs and is not required the set of spacing clamps as in the first case. Frequently the fixation of plates/slabs is accomplished/realized by split nuts, in this case on the part of the columns they cut thread.

In the back of latter/last plate/slab U-shaped strippers for the removal/output are established/installed in the mounts/mandrels of

the lengthened blank.

The construction/design of this stripper is shown in Fig. 100.

The mount/mandrel, by which the blank through the matrices/dies is forced, it is fastened on the crosshead, connected with the working plungers. Cross-beam heads either on the columns or on the frame, on which the plates/slabs are installed.

For decreasing the length of press, and also for the creation of large convenience with the load of blank into the press the mount/mandrel is made by rotary. The mechanism for the rotation of mount/mandrel, usually made by hydraulic, is installed on the crosshead.

For maintaining of mount/mandrel, and also broached blank, the presses are equipped with the supporting/reference rollers, whose lift to the different levels, determined by the diameter of blank, is accomplished/realized by hydraulic cylinders. The idling of the crosshead in the majority of presses is accomplished/realized by water from the filler tank. The auxiliary cylinders of low diameter, the high pressures fed by water sometimes for this purpose are applied. In this case filler of systems has a water of reduced pressure.

The cylinders of back stroke in the broaching presses usually are made in the columns.

The drive of broaching presses is accomplished/realized from the pump-and-battery station. In this case, if occurs the strong jamming of the blank on the mount/mandrel and of effort/force, the normally developed with cylinders recurrent course, it will prove to be insufficient, in the hydraulic system is provided for the multiplier, with the aid of which the pressure in the reverse/inverse cylinders (usually 2.5 times) is raised.

Page 123.

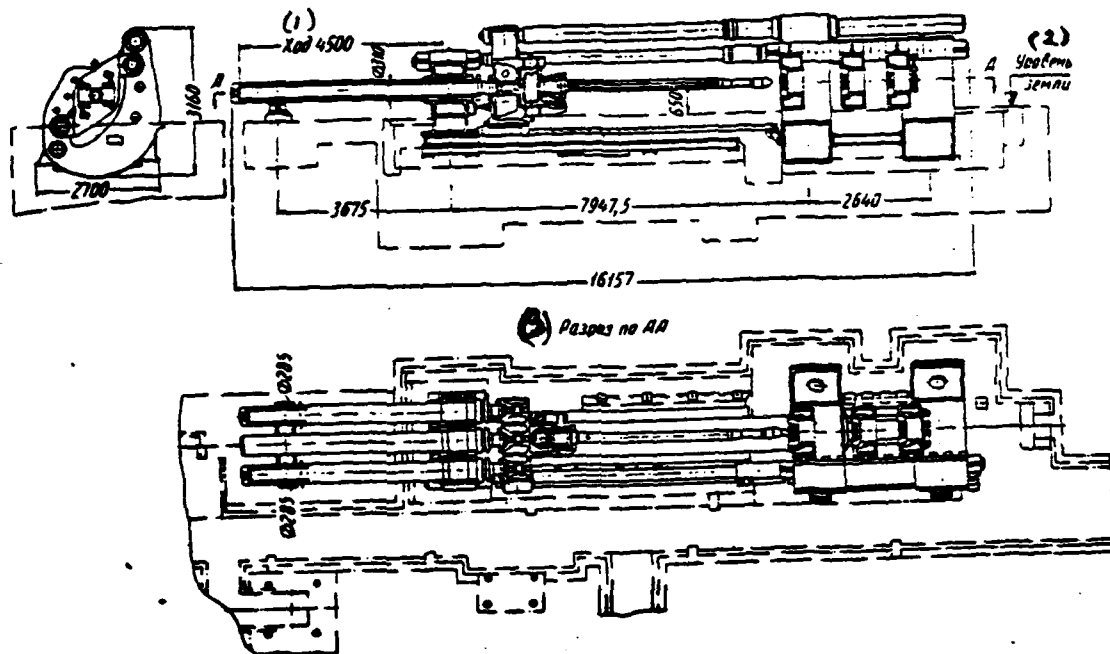

Fig. 99. General view of three-cylinder broaching press by effort/force 400 t.

Key: (1). Course. (2). Ground level. (3). Section/cut on.

Page 124.

With the absence in the system of multiplier the pull-backs must have the increased diameter. Broach on the presses is accomplished/realized at a rate of 400-500 mm/s.

Since the blank on the drawn-out press enters immediately after piercing, without reheat, piercing and broaching press are installed by series/row on one foundation and usually are controlled by one operator; sometimes piercing and broaching press is installed on one mounting (Fig. 101 and 102).

The effort/force of press for the broach is determined by the sizes/dimensions of the lengthened article:

$$P = 0,001f \cdot \sigma_{br} m,$$

where f - cross-sectional area of article in mm^2 ;

σ_{br} - limit of the strength of the material of article at a temperature of broach in kgf/mm^2 .

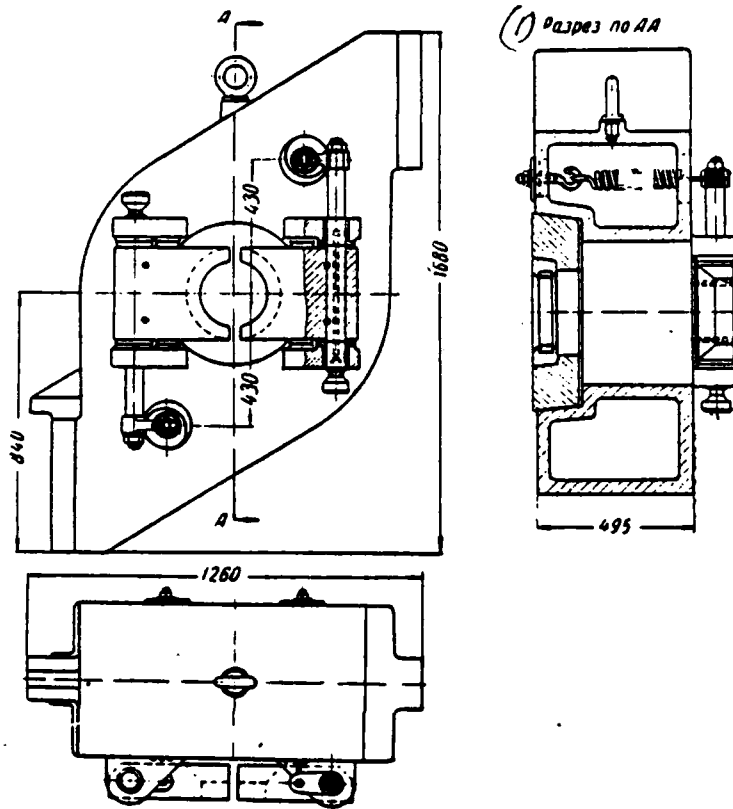

Fig. 100. Stripper, used in the broaching presses.

Key: (1). Section/cut on.

Page 125.

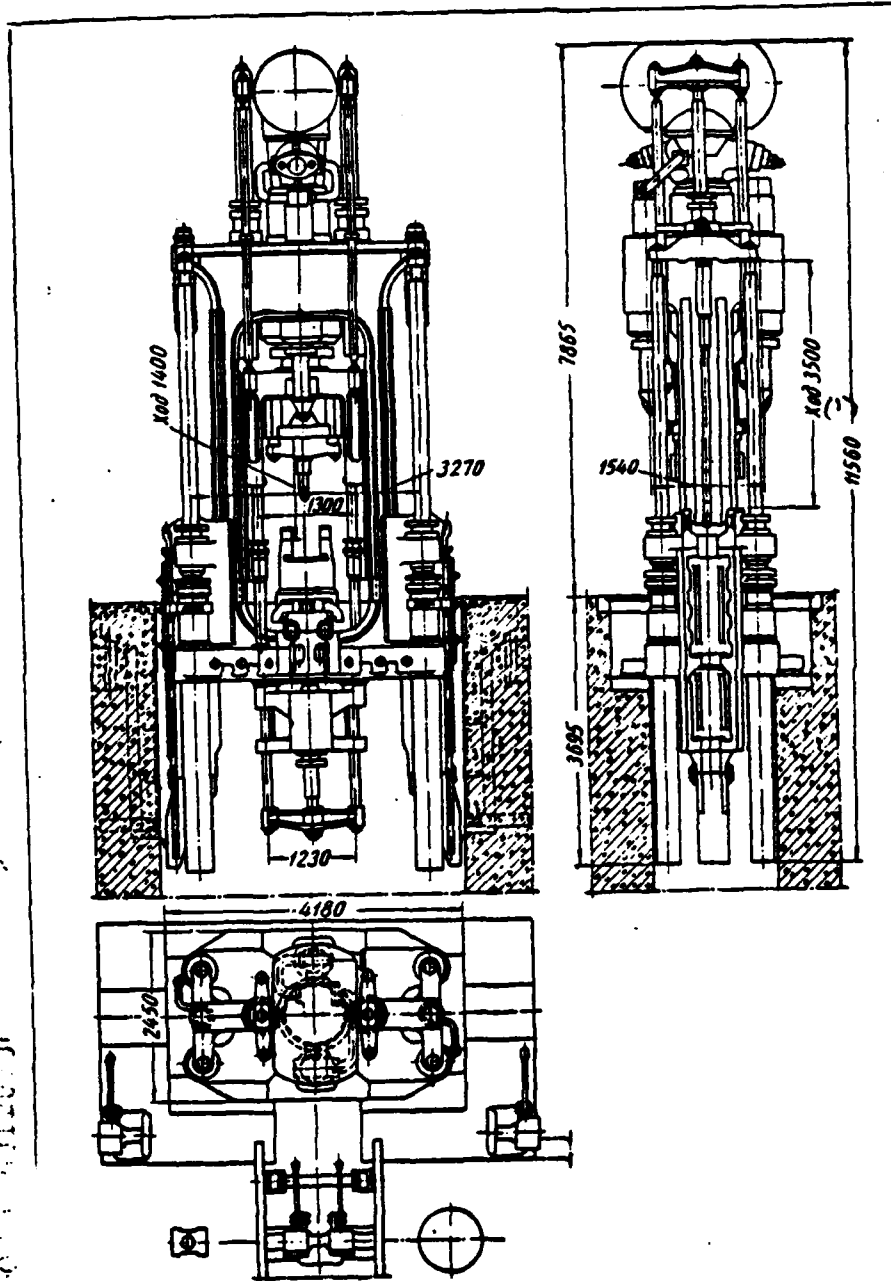

Fig. 101. Paired press: piercing by effort/force 400 t and drawn-out by effort/force 150 t.

Key: (1). Course.

Page 126.

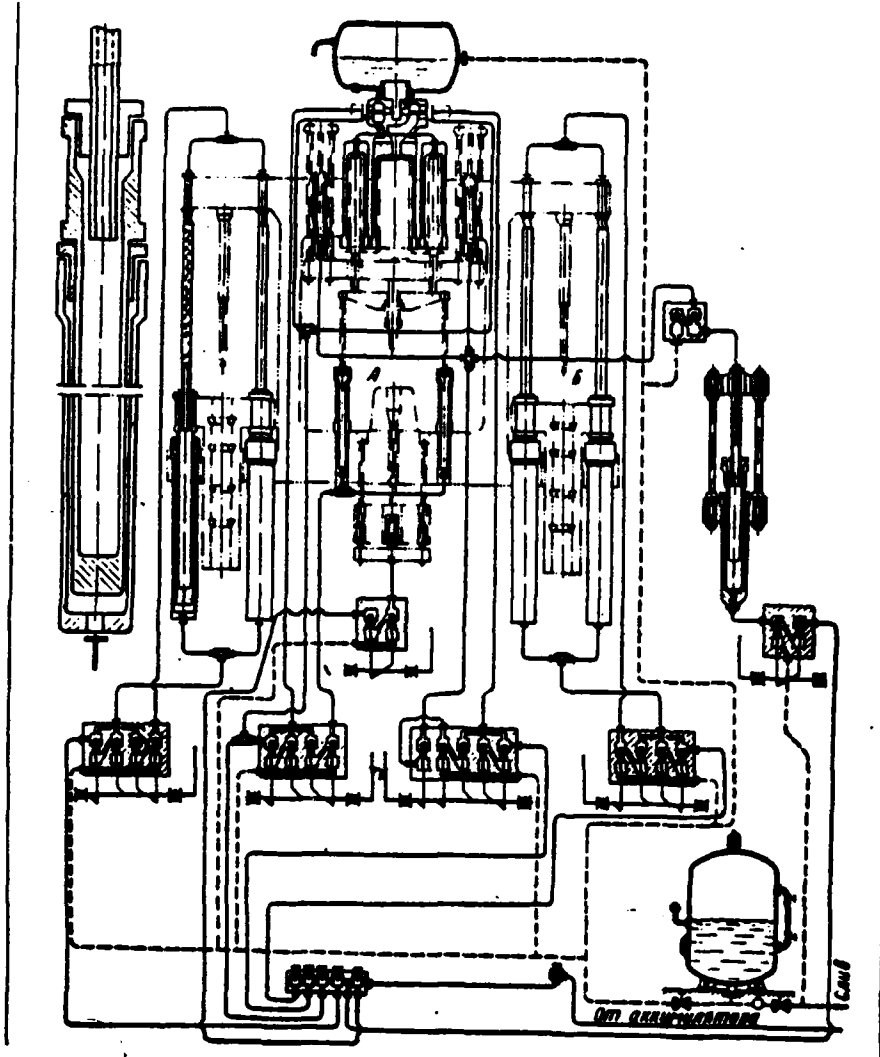

Fig. 102. Diagram paired piercing A (effort/force 400 t) and broaching B (with effort/force 150 t) press.

Page 127.

The degree of stretch in one pass is determined on the basis of the effort/force, used for the broach, which tentatively is found by formula (Fig. 103)

$$P' = 0,001 (f_1 - f_2) \sigma_i'$$

where σ_i' - specific strength of materials with the broach (for the carbon steel 20-30 kgf/mm²).

In this case P' must be less $0,001 f_2 \sigma_i'$.

The exemplary/approximate characteristics of the constructed broaching presses and relationship/ratio of the efforts/forces of the broaching and piercing presses working in pair are given in Table 13.

Manufacture of large-size bottles. By the method of piercing, subsequent broach and pricking of end successfully are manufactured such articles as large-size high pressure cylinders.

Is given below route technology and short characteristics of press and auxiliary equipment of shop for manufacturing the bottles and to them similar parts.

In the described shop can be manufactured the bottles with an outside diameter of up to 1300 mm and a length of up to 10.5 m, having net weight approximately 16 t.

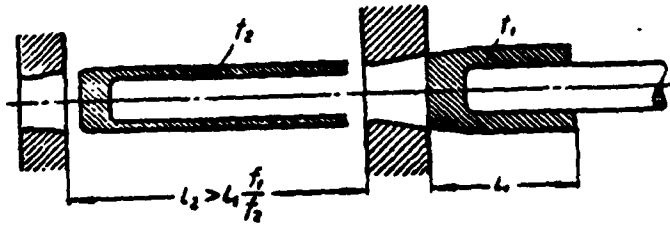

Fig. 103. Diagram of breach.

Table 13. Exemplary/approximate relationships/ratios of the basic parameters of broaching and piercing presses.

(1) Усилие, развиваемое протяжными прессами, в т	(2) Усилие, развиваемое прошивными прессами, в т	(3) Ход подвижной поперечной протяжной прессы в мм
75—100	200	1700
125—150	300	2100
200	500	3000
220—250	700	3600
260—300	1000	4200
340—400	1500	6000

Key: (1). Effort/force, developed with the drawn-out of presses, in t. (2). the effort/force, developed with piercing press, in t. (3). Course of mobile crosshead of broaching press in mm.

Page 128.

Basic equipment in the shop are the presses: vertical piercing with effort/force 5000 t, horizontal drawn-out with effort/force 1500 t and forging, that develops force on the faces 1500 t and for the bearing disk 2000 t.

Presses are given from one pump-and-battery station with the pressure of water 235 kg/cm² and having maneuvering volume 15000 l. At the station are established/installed three pumps with a power of every 440 kW.

As an example let us give the description of the manufacture of the bottle of the pump-and-battery station, which has after treatment the outside diameter of 980 mm, internal 850 mm and the overall length of approximately 7300 mm.

Bottle is designed for the pressure 210 kg/cm², its capacity/capacitance is equal to 3440 l and net weight of 13 t. Material of bottles - carbon steel with the average carbon content 0.35% C.

Blank for the bottle has a section/cut with the sizes/dimensions 955×955 of mm, with the length of 2340 mm and the weight of 16 t.

Blank from the end/face has bevels/facets on 100 mm at angle of 45°.

Rolled blank enters shop and stores/adds up to the shelves. From the shelf the blank enters machine tool for the trimming to the measured length and chamfering, after which he is supplied by suspension manipulator into the continuous furnace. Heated in the furnace to temperature of 1350°, blank by the same manipulator is charged into the soaking pit for the temperature balance. From the well it is transferred to the installation for descaling, after which it is supplied to the piercing press with effort/force 5000 t and is charged into the container established/installed on its table.

The construction/design of container and the sizes/dimensions of blank after piercing are shown in Fig. 104.

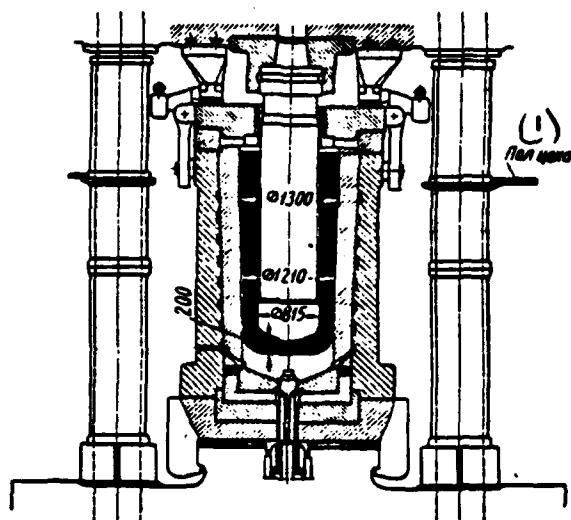

Fig. 104. Container with the pierced blank.

Key: (1). Floor/sex of shop.

Page 129.

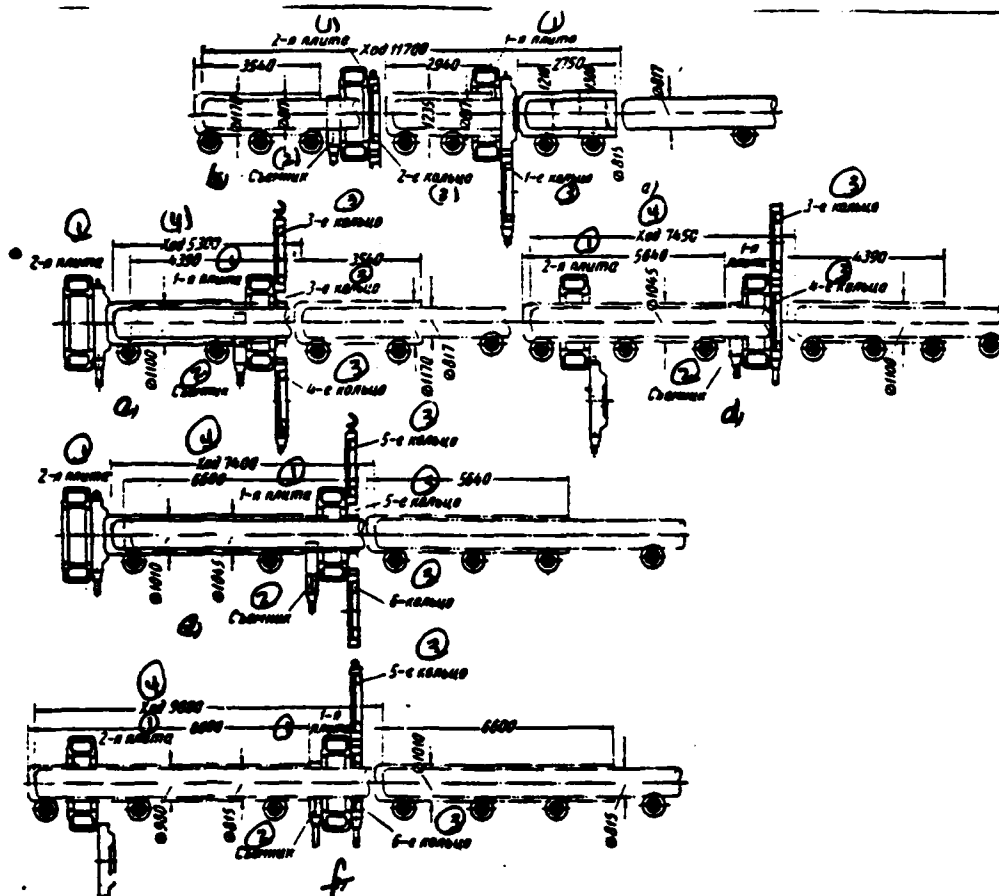

Fig. 105. Order of operations with the broach of the bottle: a) hot blank, subject from the piercing press; b) the removal/output of blank with the mount/mandrel and its removal/distance of the press for the preheating; c) load into the press of the heated blank; d) the removal/output of blank with the mount/mandrel and the removal/distance of the press for the preheating; e) load into the press of the heated blank; f) removal/distance of the press.

Key: (1). Plate/slab. (2). Stripper. (3). Ring. (4). Course.

Page 130.

The pierced blank by the tongs of tap/crane is transferred to feed roller of broaching press. After the broach through two matrices/dies the blank by the same tap/crane by load capacity 25 t is transferred to the preheat furnace, then it again is transferred on the drawn-out press for the broach through the subsequent matrices/dies. The broach of blank on the press is accomplished/realized for six transitions/transfers (broach consecutively/serially through six matrices/dies).

Operational procedure press and motion of blank with the broach, and also its sizes/dimensions after each transition/transfer are shown in Fig. 105.

The finally lengthened blank enters the shelf for the cooling, which is equipped with mechanism for its transmission to the flight/span of machining. In this flight/span is performed trimming end/face from the open end of the blank and sometimes (for the special bottles) its machining over the external and internal

surfaces.

Before the machining the bottle is annealed in the furnace. From the flight/span of machining the bottle by the table is transferred to the furnace for heating of the open end. The heated bottle is supplied to the horizontal press for the pricking and after this is packed for cooling to the shelf, from which then it is transferred to the flight/span of machining for the final machining.

Baling machines.

Wastes (scrap) of nonferrous and ferrous metals in the form of the cutting of sheet blanks, cutting out, shaving, wastes of wire, etc., and also arrived into the unsuitability articles made of the sheet material are utilized as the additional raw material at the metallurgical plants.

For the purpose of convenience in the transportation of scrap to the melting aggregates/units, and also its load in the furnace and more advantageous conduct of the process of melting the scrap is pressed into the bundles on the hydraulic presses.

Depending on package and sizes/dimensions of bundle, press they construct with two and three steps/stages of extrusion/pressing.

Specific compacting pressure at the latter/last step/stage is selected equal to 175-250 kg/cm².

In this case bundle density is obtained equal to 40-65% density of monolithic metal. The extended construction/design of stationary baling machine with three steps/stages of extrusion/pressing, developed TsNIITMASH [ЦНИИТМАШ - Central Scientific Research Institute of Technical Mechanical Engineering], it is shown in Fig. 106 and 107, and the general view of installation - in Fig. 108.

On this press laminated metal-withdrawals/metal-departures can be packed with thickness to 6 mm into the bundles with the size/dimension 400×500×500-800 of mm. The chamber/camera of press for the load of scrap has sizes/dimensions in mm: width 1400, length 2790, height/altitude 1100. At first stage of the packing of presses develops the effort/force 110 t, on second 200 t and on the third of 430 t, which corresponds to specific pressure on the bundle 245 kg/cm².

Page 131.

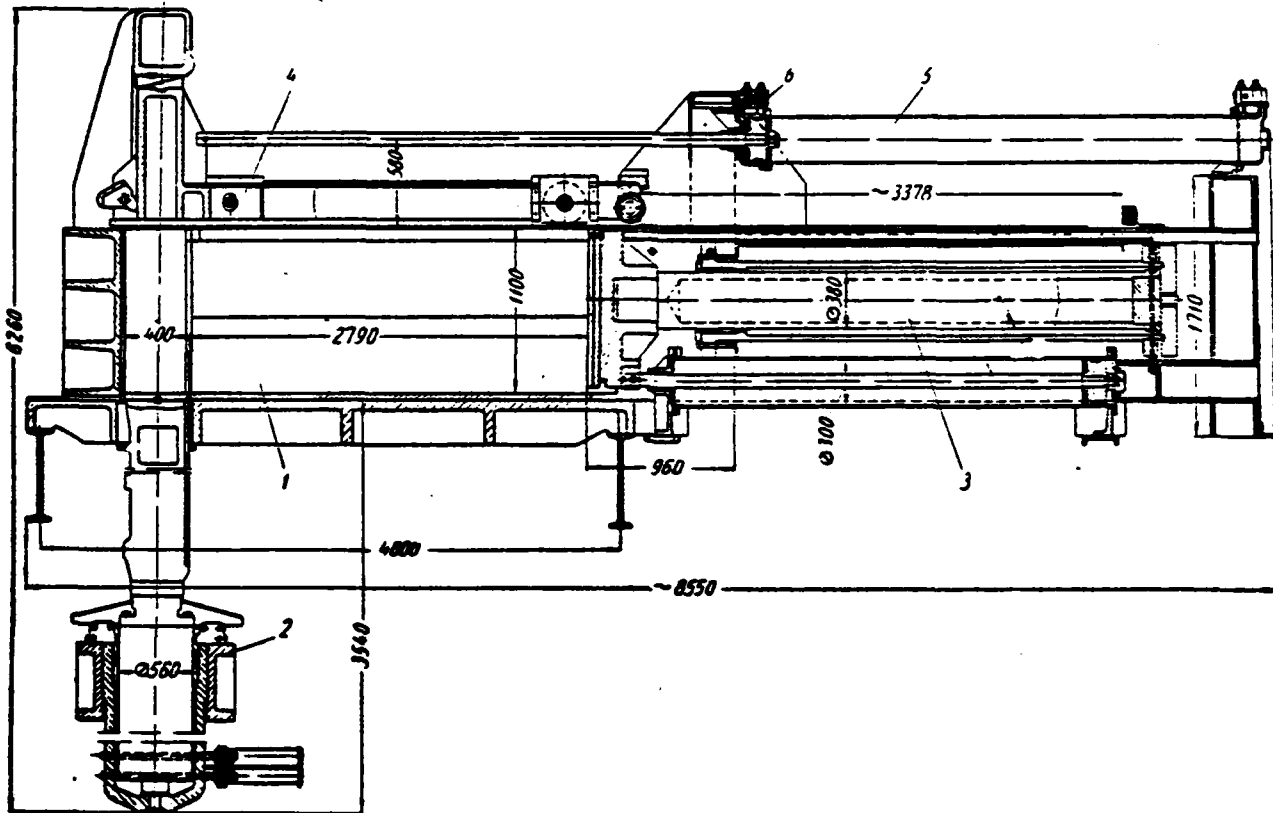

Fig. 106. Baling machine with three steps/stages of extrusion/pressing (longitudinal section): 1 - shaping bag; 2 - cylinder of the third step/stage of extrusion/pressing; 3 - cylinder of the second step/stage of extrusion/pressing; 4 - cover/cap of chamber/camera; 5 - pneumatic cylinder of the drive of cover/cap; 6 - braking device of pneumatic cylinder.

Page 132.

The weight of bundle, depending on the character of scrap, varies by 500-800 kg. Time of one molding cycle of bundle 6-7 min.

All operating mechanisms of press are established/installed on the shaping bag, which is the rigid construction/design of box-shaped form, assembled from the steel cast plates/slabs. The connection of plates/slabs is carried out on the bolts.

Sliders and chamber walls of press have steel interchangeable plates/slabs with the wavy surface, which prevents/warns the entry/incidence of the laminated scrap between the friction surfaces and the jamming of sliders. The cover/cap of the chamber/camera of press is made welded from steel plates/slabs. On the front of the cover/cap is a projection, which by its inclined upper plane goes in the massive cast strut, which is detent for the cover/cap during the extrusion/pressing.

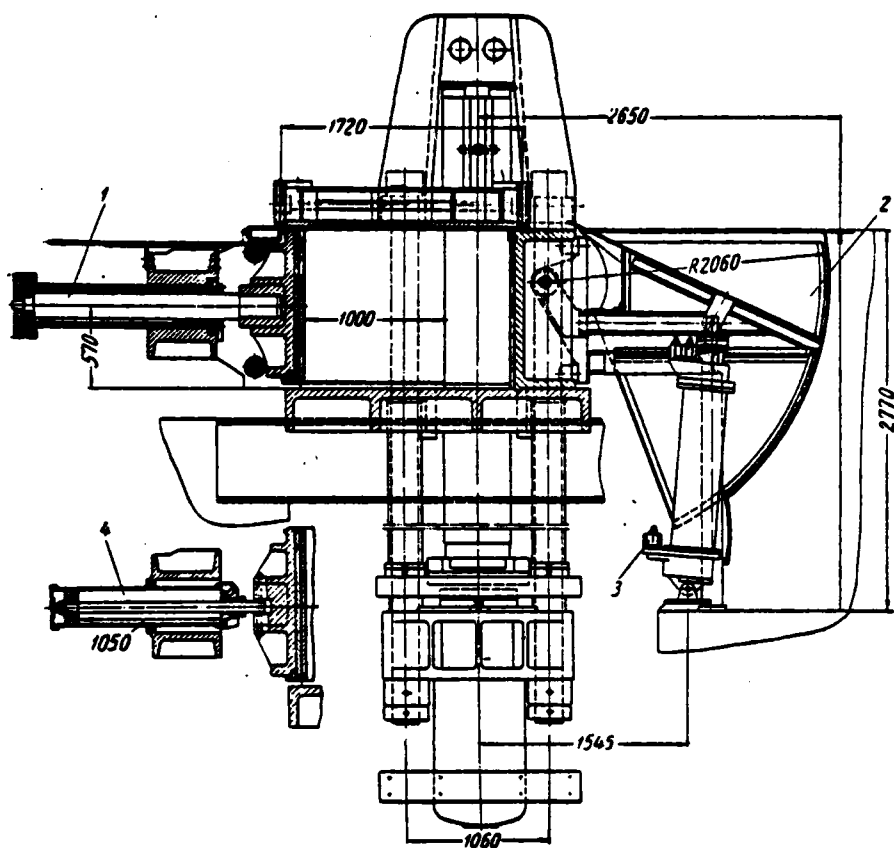

Fig. 107. Baling machine with three steps/stages of extrusion/pressing (cross section): 1 - cylinder of first stage of extrusion/pressing; 2 - charging duct; 3 - cylinder of the rotation of duct; 4 - the pull-back of the slider of first stage of extrusion/pressing.

Page 133.

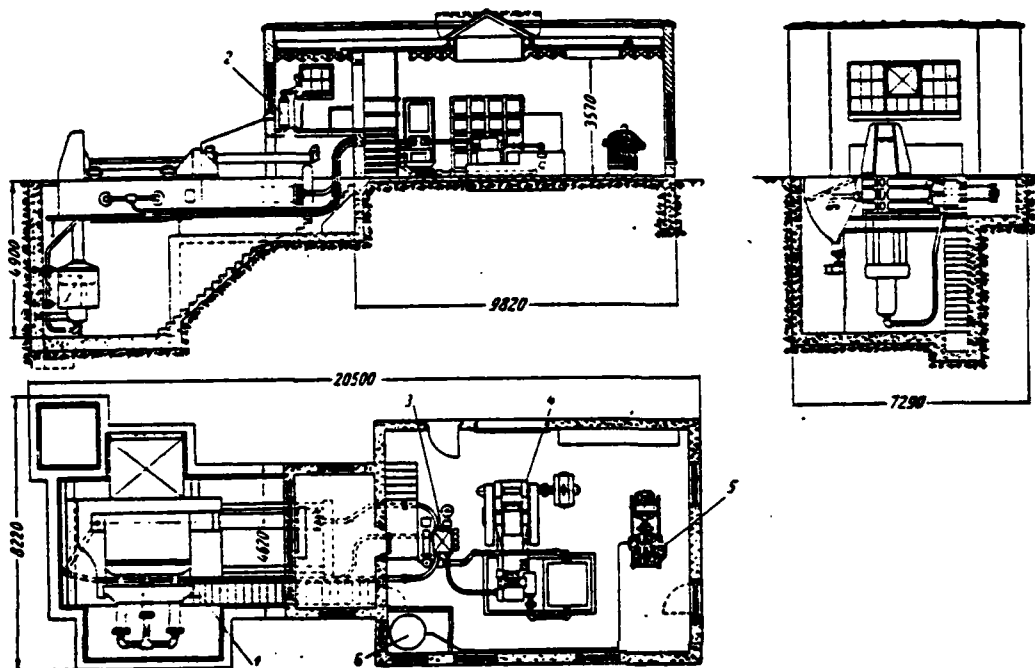

Fig. 108. The general view of the installation/setting up of baling machine with three steps/stages of the extrusion/pressing: 1 - press; 2 - control panel; 3 - valve distributor; 4 - pump; 5 - compressor; 6 - air collector.

Page 134.

The drive of cover/cap is accomplished/realized by a pneumatic cylinder. The mechanism of the first extrusion/pressing is arranged/located horizontally and consists of the pressing slider by the size/dimension 1100×2790 of mm, two hydraulic working cylinders

and one pneumatic cylinder of back stroke.

The stroke of slider of the first extrusion/pressing is equal to 1000 mm. the mechanism of the second extrusion/pressing is also arranged/located horizontally and consists of pressing slider with size/dimension 490×1000 mm, hydraulic working cylinder and one pneumatic cylinder of back stroke. The stroke of slider of the second extrusion/pressing is equal to 2790 mm.

The mechanism of the third, final, extrusion/pressing is arranged/located vertically and consists of the pressing slider by the size/dimension 400×490 mm and one hydraulic cylinder of one-sided action. The return of this slider to the initial position occurs under its own weight. The complete stroke of slider of the third extrusion/pressing is equal to 1100 mm. The slider of the third extrusion/pressing is utilized also for the knockout of bundle from the press.

For increasing the productivity of press from the side the shaping bag is a charging duct, whose tilting/reversal is produced with the aid of the pneumatic cylinder.

Hydraulic pressure cylinders are given from three-plunger pump with two pressure stages and supplies. The first pressure stage (50

kg/cm²) is utilized for the primary and secondary extrusion/pressing, in this case the supply of pump is equal to 1200 l/min. At the second step/stage the pump develops pressure 175 kg/cm² during the supplying 360 l/min. Pump is given from the electric motor with a power of 140 kW.

For the drive of pneumatic cylinders press installation/setting up has the two-stage compressor, which develops pressure 7 kg/cm².

Productivity of compressor 5.28 m³/min. Compressor is driven by the electric motor with a power of 44 kW with the number of revolutions 720 per minute.

About the compressor the air collector is established/installed by the volume of 3 m³. Control of pneumatic cylinders is accomplished/realized with the aid of the common taps/cranes. The control/check of the end of the extrusion/pressing at each step/stage is accomplished/realized by indicator lamps. Pump, compressor and all equipment for control of press are installed near the press in the special location, whereas press itself can be established/installed on a scrap pile on the closed pad or under the mounting fixture.

The press of considerably smaller power with two steps/stages of extrusion/pressing for the packing of the scrap of the nonferrous and

ferrous metals with a thickness of up to 3 mm into the bundles with the size/dimension 250×300×500 of mm is shown in Fig. 109. Chamber/camera for the load of its scrap has sizes/dimensions: the width of 700 mm, the length of 1780 mm, the height/altitude of 500 mm.

Press is carried out with two steps/stages of extrusion/pressing. For first stage of extrusion/pressing maximum effort is equal to 70 t. At the second step/stage of presses the effort/force 100 t develops, which corresponds to specific pressure on the bundle at the end of the extrusion/pressing 80 kg/cm².

The average weight of bundle from the steel wastes is equal to approximately 80 kg, in this case bundle density is equal to 25-30% of the density of monolithic metal.

Page 135.

The average efficiency of the press of 7 bundles an hour.

Overall dimensions of the press: the length of 5450 mm, the width of 2400 mm, the height/altitude of 2330 mm, the total weight of its 9000 kg. All actuators and control of press are arranged/located on its mounting. Low dimensions and weight of press give the

possibility to establish/install it in the flatcar or directly on the soil; it is convenient for the transportation and can be used without any preparatory works in any place, where there is electric power of three-phase current. The mounting of press is made welded from steel sheets. The rigidity of mounting is provided by a sufficient quantity of edges/fins, welded to its walls. For the movement of press by the soil its mounting is assembled on three H-beams.

The chamber/camera, charged by scrap, before the extrusion/pressing is closed by the massive cover/cap, which has on end the lock, with the aid of which its dense coverage and light discovery/opening after extrusion/pressing is provided.

For the removal/distance of the pressed bundle from the chamber/camera the hoist with hand winch, established/installed on the mounting of press, is used.

The drive of cover/cap, and also sliders of the first and second extrusion/pressing is accomplished/realized by the hydraulic cylinders, fed from the rotary pumps: one pump with the supply 70 l/min with the electric motor with a power of 9.1 kW and another with the supply 100 l/min and the electric motor with a power of 11.8 kW.

In this case for the drive of cover/cap only one pump with the supply 70 l/min is utilized.

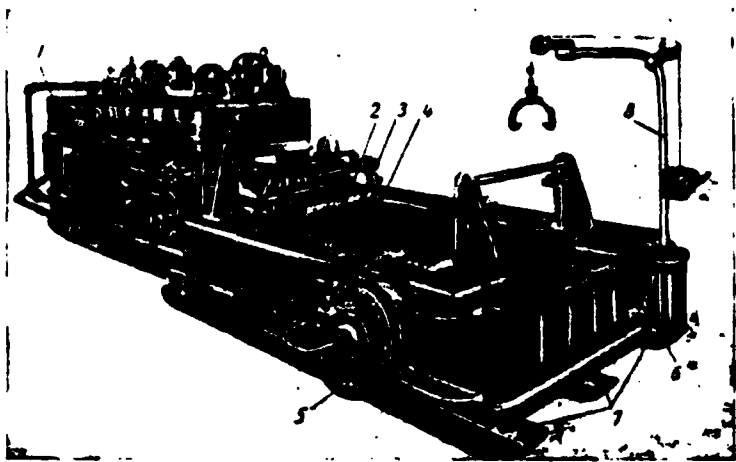

Fig. 109. Baling machine with two steps/stages of the extrusion/pressing: 1 - drive of press (pumps, electric motors, control valves, tank); 2 - cover/cap of chamber/camera; 3 - the cover plate lock of chamber/camera; 4 - slider of first stage of extrusion/pressing; 5 - cylinder of the second step/stage of extrusion/pressing; 6 - mounting of press; 7 - channel bar; 8 - hoist.

Page 136.

For observing the sequence of moving the mechanisms of press in the hydraulic system valve-autoswitches are established/installed. With the aid of these valves is accomplished/realized the following sequence in the work: the discovery/opening the cover/cap of chamber/camera, load by a scrap; the first extrusion/pressing with

the effort/force 70 t; the second extrusion/pressing with the effort/force 100 t; the disclosure/expansion of chamber/camera and the branch/removal of the pressing sliders into the initial position. Entire/all hydraulic system works on mineral oil with the maximum pressure in the system 65 kg/cm².

BALING PRESSES.

The briquetting of cast iron and steel shaving, and also shaving of nonferrous metals successfully is accomplished/realized on the hydraulic horizontal presses. One of the constructions/designs of press is shown in Fig. 110.

Presses are constructed with the efforts/forces to 600 t; the productivity of powerful/thick presses with the briquetting of cast iron shaving is 5.5-6.5 t/h.

The exemplary/approximate characteristics of baling presses are given in Table 14. The schematic diagram of the device of press is shown in Fig. 111, and the installation/setting up of instrument on the press - 112.

Briquetting is produced in steel bushing 1 (Fig. 111) by male die/punch 2, fastened/strengthened to the main crosshead of press.

DOC = 83120707

PAGE

257

The bushing, in which the briquetting occurs, is assembled in mobile container 3, given by hydraulic cylinders.

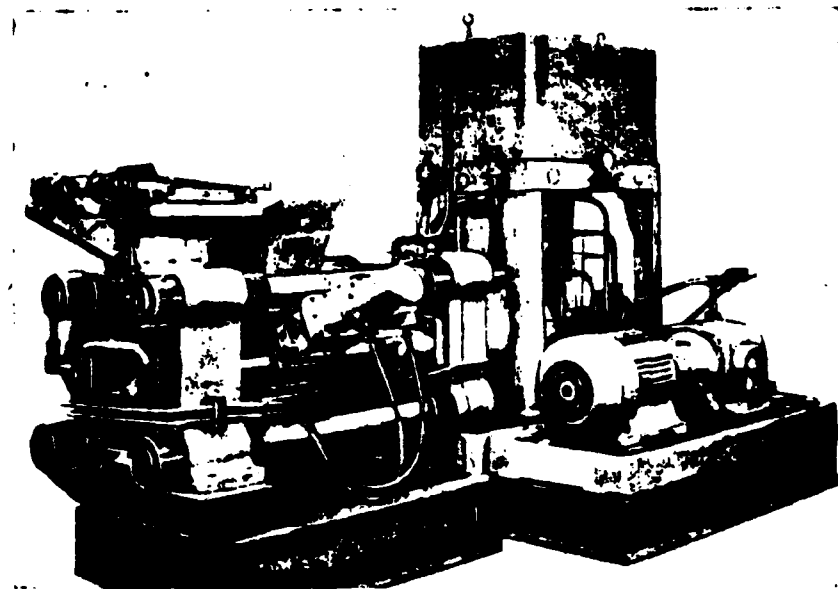

Fig. 110. Hydraulic baling press with force 400 t.

Page 137.

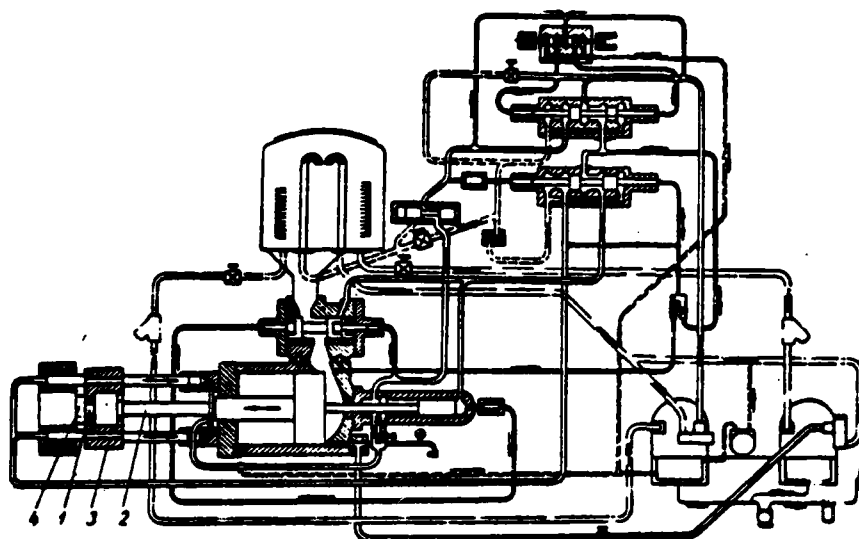

Fig. 111. Schematic diagram of the device of hydraulic baling press.

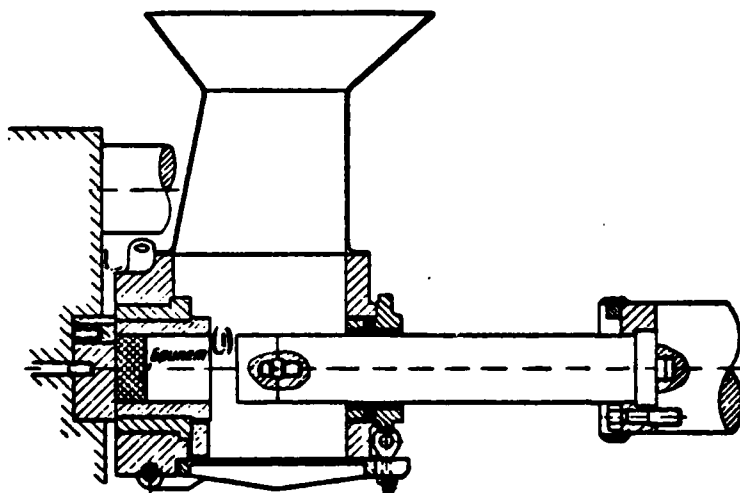

Fig. 112. The installation/setting up of the instrument of baling press.

Key: (1). Briquette.

Page 138.

When briquetting is completed, container is moved on the working male die/punch, leaving briquette by pressed between the male die/punch and base plate 4. During the reverse motion of male die/punch the freed briquette separates out from the press. For the best filling of bushing with shaving in the container, where shaving enters, occurs its pre-pressing by the pneumatic cylinders, assembled on side walls of container (Fig. 113).

For obtaining necessary density (80-90%) steel briquette is pressed with the specific pressure 1750-2500 kg/cm², and cast iron - with the pressure 2300-3500 kg/cm².

Table 14. Exemplary/approximate characteristics of baling presses.

(1) Параметры	(2) Усилие пресса в т			
	100	300	400	600
(3) Ход прессующего пуансона в мм . . .	300	400	500	500
(4) Размеры (диаметр × высота) готового брикета в мм	∅ 85 × 30—60	∅ 130 × 35—75	∅ 150 × 75—100	∅ 180 × 75—100
(5) Вес готового брикета в кг	1—2	3—6	7,5—10	11—15
(6) Часовая производительность в шт.	700—800	600—700	500	500

Key: (1). Parameters. (2). Effort/force of press in t. (3). Stroke of the pressing punch in mm. (4). Sizes/dimensions (diameter × height/altitude) of finished briquette in mm. (5). Weight of finished briquette in kg. (6). Hourly productivity in pcs.

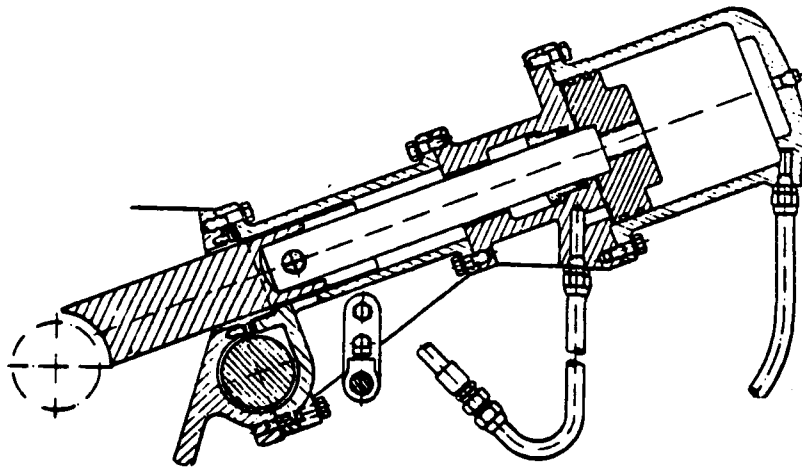

Fig. 113. Construction/design and calculation of the premolding mechanism of baling press.

Page 139.

Chapter 3.

CONSTRUCTION AND CALCULATION OF BASIC ASSEMBLIES AND PARTS OF PRESS.

Sealing/packing/compaction of plungers and fixed compounds.

Sleeves and half-collars. Sealings/packings/compactions of plungers, pistons, stocks/rods, etc. in the cylinders against the leaks/leakages of working fluid, which is located under the high pressure, are the most critical/heaviest-duty units of hydraulic press.

The poor quality of sealing/packing/compaction is the reason for rapid stops to the repair of press equipment, causes the increased flow rate of the leaks/leakages of liquid from the system of press, it raises in price its operation and is created difficulty with the work on press.

Therefore to a selection of the type of sealing/packing/compaction and to the guarantee of its high quality must be given serious attention during the design to the operation of

hydraulic presses. Sealing/packing/compaction must create the required seal, be durable in the operation, not cause the strong wear of the friction surfaces, have the low coefficient of friction, be inert with respect to the material of mating members and working fluids, be stable during the oscillation/vibration of the temperature of working fluid. Furthermore, sealings/packings/compactions must be simple in the manufacture, cheap and reliable.

In the early constructions/designs of hydraulic presses for sealing/packing/compaction of plungers it was applied stump or knock, impregnated with grease. Such sealings/packings/compactions have the high coefficient of friction, require rapid the suspenders and therefore in the contemporary constructions/designs of presses barely are applied.

At present for sealing/packing/compaction of moving elements (plungers, stocks/rods) apply the circular pressed single-row sleeves and half-collars (Fig. 114 and 115), and also herringbone type polyserial sleeves (Fig. 116). The latter received the widest use. Sleeves are manufactured on the presses by formation in the molds. For convenience in the setting and replacement herringbone polyserial sleeves can be made by split ones. The standard sizes of herringbone sleeves and thrust rings are given in Table 15.

Page 140.

The recommended quantities of sleeves in the unit of sealing/packing/compaction, depending on the diameter of plunger and pressure of working fluid, are given in Table 16 (Fig. 117).

Single-row sleeves and collars manufacture from the skin, vinyl chloride or rubber, and polyserial herringbone sleeves - from the rubberized cotton fabric.

Leather is one of the worse/worst sealing materials: it little is elastic, and therefore at low pressures (to 20-30 kg/cm²) of sleeve from the skin hermetically sealed sealing/packing/compaction is not created; sleeves from leather at high pressures rapidly are destroyed, since leather is not strong (limit of its strength with the elongation is approximately equal to 2.5 kgf/mm²); leather has low oil resistance; its cost/value is higher than cost/value of other materials used.

Table 15. The standard sizes of herringbone polyserial sleeves (Fig. 116).

Номинальные диаметры плунжеров d_1 , в мм	(2) Размеры уплотнительных колец в мм										
	B	b	H_1	H_2	H_3	h	h_1	h_2	h_3	R	r
20—55	10 ± 0.7	2	5.5	8 ± 0.7	10	2	2	4.2	6.5	3	1
60—105	12 ± 0.7	2.5	7	10 ± 1	12.5	2.5	2.5	5.3	3	3.75	1.25
105—210	15 ± 0.7	3	8	12 ± 1	15	3	3	6.4	10	4.5	1.5
220—710	20 ± 0.7	4	11	16 ± 1	20	4	6	8.5	13	6	2
750—1400	25 ± 1	5	14	20 ± 1.2	25	5	5	10.6	16	7.5	2.5
1500—2000	30 ± 1	6	17	2.4 ± 1.5	30	6	6	12.7	19	9	3

Key: (1). Nominal diameters of plungers d_1 , in mm. (2). Sizes/dimensions of ferrules in mm.

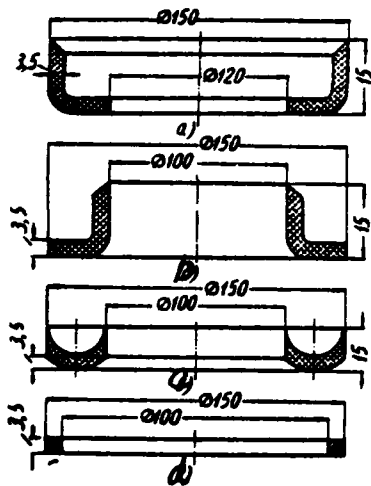

Fig. 114.

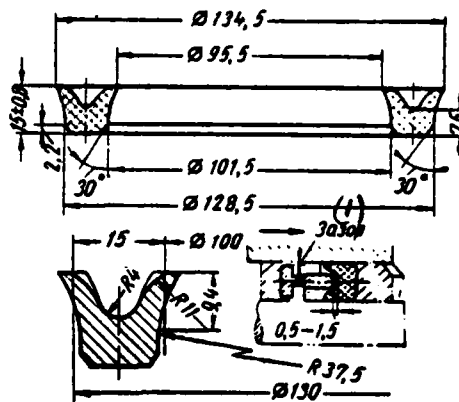

Fig. 115.

Fig. 114. Leather seals according to GOST 2749-52: a) sleeve piston; b) the sleeve of stock/rod; c) half-collar; d) ferrule.

Fig. 115. Sleeves (collars) rubber according to GOST 6969-54.

Key: (1). Clearance.

Page 141.

During the use/application of leather cups for sealing/packing/compaction of stocks/rods and plungers made of the stainless steel the erosion appears at the metallic surface. Erosion is the corollary of the electrolytic process, which appears in the process of the dissolution of salts, that contain in the leather. The erosion of rod occurs not during its slip in the sleeve, but with the fixed contact of metal with the sleeve.

Fig. 118 shows defects on the surface of the rod made of the stainless steel, which was located in the contact with leather cup during six weeks.

The PVC plastic material, used for the sleeves, is sufficiently to stable ones both in the form and in oils. The coefficient of the friction of polyvinyl chloride in steel composes small value.

Table 16. Recommended quantity of sleeves in the unit of sealing/packing/compaction depending on the diameter of plunger and pressure of working fluid.

(1) Диаметр уплотняемого плунжера d в мм	(2) Ширина уплотнения B в мм	(3) Рабочее давление в кг/см ²											
		64		100		200		320		400		500	
		Количество манжет в комплекте (5)	H в мм	Количество манжет в комплекте (5)	H в мм	Количество манжет в комплекте (5)	H в мм	Количество манжет в комплекте (5)	H в мм	Количество манжет в комплекте (5)	H в мм	Количество манжет в комплекте (5)	H в мм
20—55	10	3	24,6	3	24,6	3	28,8	3	28,8	4	33	6	37,2
60—100	12,5	3	30,9	3	30,9	3	35,2	4	36,2	5	41,5	6	46,8
105—280	15	3	43,6	3	50	4	50	5	50	6	56,4	7	62,8
300—710	20	3	58	4	66,5	5	75	6	75	7	83,5	8	92
750—1400	25	4	72,4	5	83	6	93,6	7	104,2	8	114,8	9	125,4
1500—2000	30	5	99,5	6	112,2	7	124,5	8	137,6	9	150,3	10	163

Key: (1). Diameter of the packed plunger d in mm. (2). Width of sealings/packings/compactions B in mm. (3). Operating pressure in kg/cm². (4). Quantity of sleeves in the assembly. (5). H in mm.

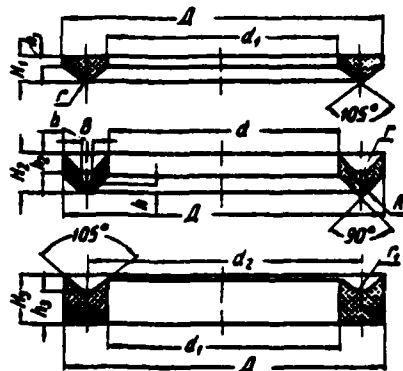

Fig. 116.

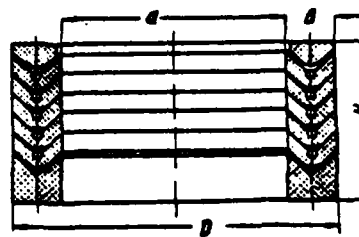

Fig. 117.

Fig. 116. Sleeves herringbone polyserial (sizes/dimensions see Table 15).

Fig. 117. Set of sleeves in the unit of sealing/packing/compaction (Table 16).

Page 142.

A shortcoming in the PVC plastic material is relatively low strength, in consequence of which at high pressures it "ensues/escapes/flows out" into the clearance between the plunger and the bushing. For the satisfactory work of vinyl chloride sleeves this clearance must be less than 0.15 mm.

For manufacturing the sleeves also is applied oil-resistant, average/mean hardness elastic rubber compound.

Polyserial herringbone sleeves are manufactured from the rubberized and graphitized cotton fabric. Rubber for the sleeves and the rings must possess the following mechanical properties: surface Shore hardness of 80-90 units; tensile strength - is not less than 80 kg/cm²; aspect ratio - is not less than 100%; permanent elongation - is not more than 5%; oil resistance in 24 hours with 20°C by weight 3%; gasoline resistance under the same conditions 20%;

thermo-swelling in 6 hours, at 100°C by weight 3%; cold resistance - 40°; the index of abrasion - is not more than 400 cm³/kW-h.; the resistance to lamination - is not less than 2 kg/cm².

The qualitatively manufactured sleeves and the rings from the fabric "domestik", properly rubberized, during the normal operation of press in two replacements, serve without the considerable wear of more than 6 months. During the testing under laboratory conditions at different pressures (200-800 kg/cm²) with the work on emulsion and mineral oil such sleeves withstood without considerable wear more than 500 thousand piston strokes (with the value of course 100 mm, the diameter of plunger 100 mm and speed of plunger 200 mm/s).

The amount of force of friction of sleeves against the plunger is the important index of quality of sleeves, which depends on surface finish characteristics of plunger, working medium (oil or emulsions), degree of preparation of sleeve against plunger, etc.

Some experimental data about forces of friction of sleeves against the plunger are given on the graphs, shown in Fig. 119 and 120.

If for the working cylinders, which develop large efforts/forces, the amount of force of friction in the

sealing/packing/compaction is relatively small and its effect on the technological characteristic of press is negligible, then neglect of forces of friction during the calculation of hydraulic devices with plungers and stocks/rods of low diameters (for example, valve distributors, valves, etc.) can lead to the fact that these devices will prove to be inefficient.



Fig. 118. Erosion of stock/rod made of the stainless steel from leather cup.

Page 143.

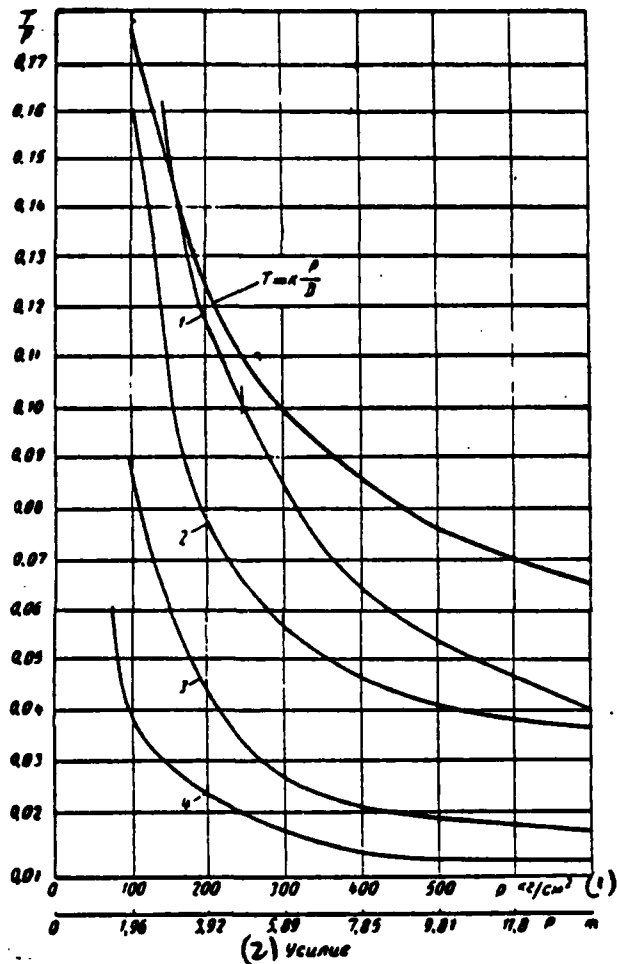

Fig. 119. Graphs of relative losses to the friction of plunger in the unit of sealing/packing/compaction. The diameter of plunger 50 mm; working medium - emulsion; sealing/packing/compaction - herringbone: 1 - after 500000 courses; 2 - after 600000 courses; 3 - after 700000 courses; 4 - after 900000 courses.

Key: (1). kg/cm². (2). Effort/force.

Page 144.

Force of friction in sealing/packing/compaction of plunger tentatively can be counted according to the empirical formula

$$T = k \cdot \frac{P}{D}, \quad (1)$$

where T - force of friction in kg;

P - force, developed with plunger, in kg;

D - diameter of plunger in cm;

k - test coefficient; with the work on emulsion k=0.6-0.8 and on oil - k=0.35-0.40 (larger values k for the smaller diameters of plungers).

With the work of press on emulsion, for decreasing force of friction of sleeves against the plunger, one should in the pressure/clamping flange make channel for consistent grease. standard designs of the units of sealing/packing/compaction with the use/application of sleeves and half-collars are given in Fig. 121-123.

the stuffing boxes (main bush) of the unit of sealing/packing/compaction must be manufactured from the high-quality perking brass of the type Бр. ОЦ 6-6-3, since they with the eccentric functioning on the plunger load test/experience high specific pressures and rapidly they are worn.

Flanges and the bolts of sealing/packing/compaction manufacture from fine steel (steel 35 or St. 5).

Their calculation is produced to the effort/force, equal to

$$N = \frac{\pi(D^2 - d^2)}{4} p \text{ to kg,} \quad (2)$$

where D and d - sizes/dimensions in cm (on Fig. 121);

p - the operating pressure of liquid in kg/cm².

In this case the allowable stress is taken as sufficiently low and equal to 800-1000 kg/cm².

Fiber sealings/packings/compactions. With exception of union couplings, rings from the fiber are the basic form of static seals in the hydropresses.

270

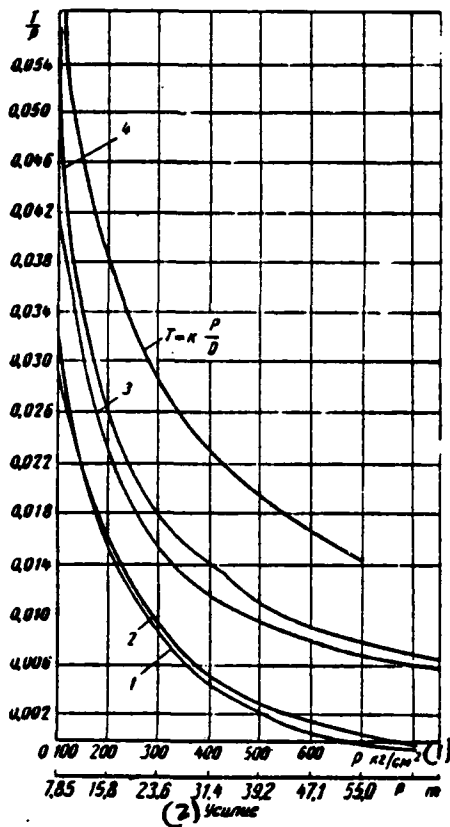

Fig. 120. Graphs of relative losses to the friction of plunger in the unit of sealing/packing/compaction. the diameter of plunger 100 mm; working medium - oil; sealing/packing/compaction - herringbone: 1 - after 150000 courses; 2 - after 250000 courses; 3 - after 400000 courses; 4 - after 500000 courses.

Key: (1). kg/cm^2 . (2). Effort/force.

Such rings, for example, are applied for sealing/packing/compaction of bushings in the valve blocks (Fig. 124), for sealing/packing/compaction of plugs, the covers/caps of housings and so forth, etc.

For manufacturing ferrules must be used only the monolithic fiber (worked out the rag paper - 100% of cotton filament), which has the following indices: the specific weight of 1.35-1.4 g/cm³; tensile strength lengthwise 650-700 kg/cm², in the transverse direction 350-380 kg/cm²; moisture 4.5-5%; absorbability in 24 hours of water 10-11% and oil 0.3-0.5%.

During the use/application of a fiber of glued or with the worse/worst indices ferrules are destroyed or are stratified, and after the brief time of operation sealing/packing/compaction leaks.

Union couplings. In the hydraulic press equipment the assembly of ducts/tubes/pipes and their attachment/connection to the cylinders and the housings are accomplished/realized mainly by flanges. To the flanges for the pressures to 200 kg/cm² there are standards, by which eight types of different constructions/designs (GOST 1233-54) are contained.

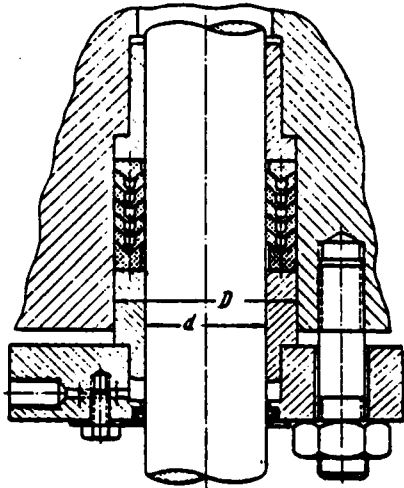

Fig. 121.

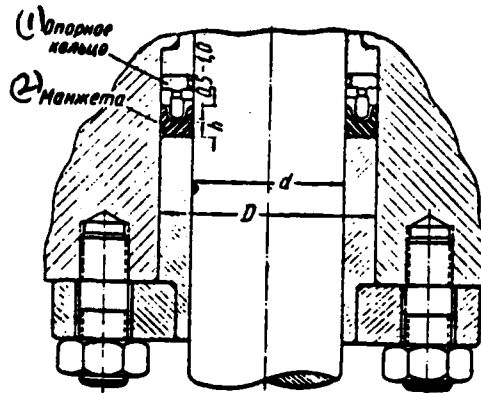

Fig. 122.

Fig. 121. Example of the installation/setting up of herringbone polyserial sleeves.

Fig. 122. Example of the installation/setting up of rubber gasket according to GOST 6969-54.

Key: (1). Carrier ring. (2). Sleeve.

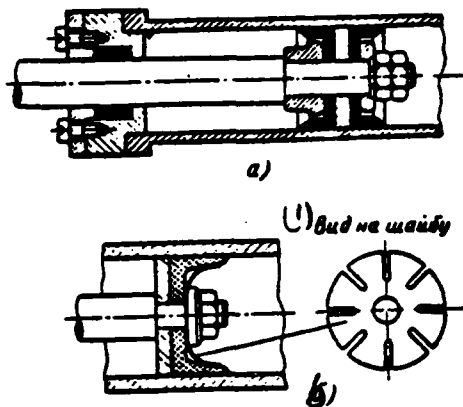

Fig. 123. Examples of the installation/setting up of piston sleeves according to GOST 2749-52: a) the cylinder of double action; b) the cylinder of single action.

Key: (1). View of washer.

Page 146.

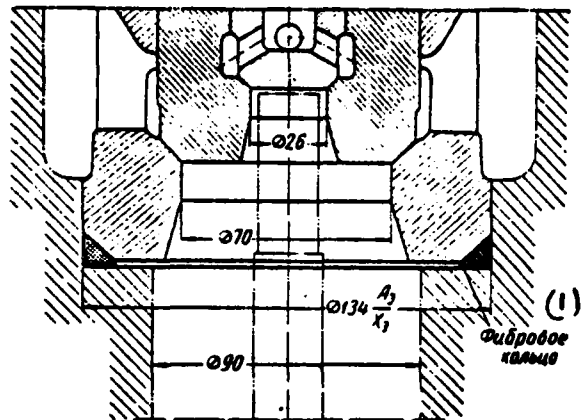

Fig. 124. Fiber sealing/packing/compaction of the bushing of valve.

Key: (1). Fiber ring.

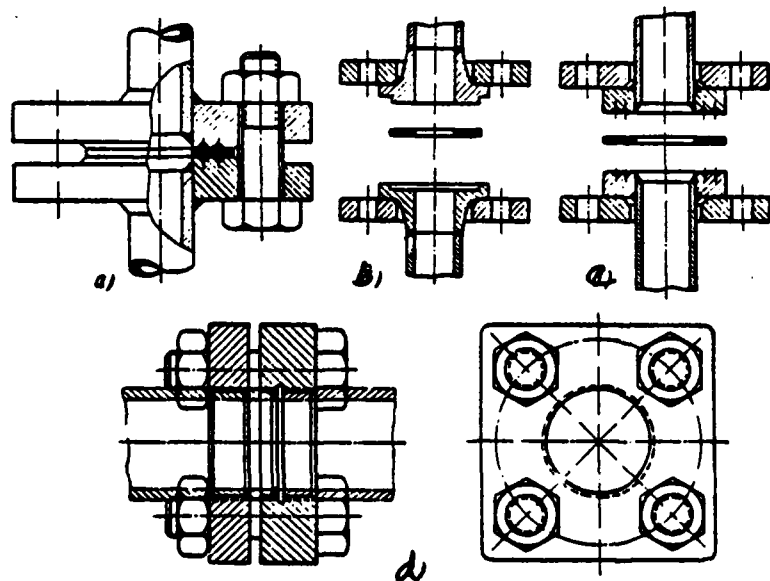

Fig. 125. Types of the flange joints of the conduits/manifolds: a) for the pressures 6-16 kg/cm²; b) for the pressures 64-100 kg/cm²; c)

for the pressures to 25 kg/cm²; d) for the high pressures (to 400 kg/cm²).

Page 147.

Are standardized also the coupling dies of flanges and fastening (GOST 1234-54) and sealing surfaces (GOST 6971-54).

The widest use for the hydraulic press installations/settings up received the flanges: type IV according to GOST 1255-54 for the pressures 6-16 kg/cm² (Fig. 125a), type VI according to GOST 1265-54 for the pressures 64-100 kg/cm² (Fig. 125b), type VII according to GOST 1268-54 for the pressure to 25 kg/cm² (Fig. 125c).

For the conduits/manifolds, which work with pressures by 200, 320, 400 kg/cm² are above, most frequently are applied the flanges, which are combined with the ducts/tubes/pipes on the thread. The assembly of flange with the duct/tube/pipe on the thread facilitates the installation of conduit/manifold, since in this case has the capability by partial folding or turning on of flange to compensate an inaccuracy in the sizes/dimensions along the length of prepared/prefabricated for the installation ducts/tubes/pipes.

Flange joints depending on the sizes/dimensions of

conduit/manifold and operating pressure are made on two bolts (rectangular flanges), four (square) (Fig. 125d) and on six or eight bolts.

As sealing/packing/compaction of compound the packing from the annealed red copper or the ARMCO iron are applied. Gasket seats, and also faces of ducts/tubes/pipes and flanges, touching the packing, must be thoroughly machined. Nicks on these surfaces are not allowed/assumed, since they are the reason for the leak of the liquid through the sealing/packing/compaction. For guaranteeing the seal of sealing/packing/compaction on the surfaces of ducts/tubes/pipes and flanges, which are touched from packing, are obtained satisfaction the circular shallow grooves (with radius of 0.5-1.5 mm), into which "flows in" the packing during its strain by the tightening of bolts. The calculation of the bolts of flange joint is performed on the specific pressure on the packing, the equal one-and-one-half or double operating pressure of liquid in the conduit/manifold.

Allowable stress during the calculation of the bolts, manufactured from steel 35 or St. 5, accept not more than 800 kg/cm².

Cylinders.

The construction/design of cylinder is chosen depending on

designation/purpose, general/common/total design concept of press, operating pressure of liquid, diameter of plunger and its course and other factors.

Strictly cylinder (Fig. 126) consists of the following elements/cells: bottom (cupola 1); cylindrical part of 2; bearing flange 3; the place of the transition/transfer of cylindrical part into flange 4; boring with bushing and sealing/packing/compaction 5; fastening conduit/manifold 6; collar 7, which imparts hardness to the open end of the cylinder (with its support to the bottom or to the flange, arranged/located not on the end of the cylinder); supporting/reference area/site for plunger 8; choke/throttle 9 for braking of fluid flow, which emerges from the cylinder; band 10 for centering the cylinder in the cross-beam; fastening 11 cylinders to the upper cross-beam; air and drain plug 12.

Page 148.

Depending on the construction/design of cylinder separate from the enumerated elements/cells can be absent.

Their bottoms (cupolas) have the greatest difference in the constructions/designs of cylinders.

In the cast, small along the length cylinders, and also when filler tank directly on the cylinder is established/installed, bottom is made by flat/plane. With accomplishing of bottom in the form of cupola its form is made close one to the hemisphere.

In forged cylinders with the pricking of the open end in the shaped faces the form of bottom also approaches the hemisphere (see Fig. 36) and with the pricking by steps/stages under the platens - to the cone (see Fig. 17, 18).

In large-diameter cylinders the bottom is frequently made by removable, pressed into the cylinder (see Fig. 82). In this case the manufacture of cylinder is simplified, but difficulties with sealing/packing/compaction of the bottom appear.

At present with the mastery/adoption of electroslog welding the cylinders of powerful/thick presses are manufactured with the welded separately finished forging bottom, which considerably reduces the labor consumption for manufacture.

One of the constructions/designs of this cylinder is shown in Fig. 127.

For the direction of plunger into the cylinder the bronze

bushing, whose length is taken as equal to approximately $3/4$ bores, is pressed. The internal surface of bushing must be finely finished with the precision/accuracy in the 2nd class under the medium fit. by the material of bushing is chosen high-quality bronze of the type Sp. OUC 6-6-3, capable of maintaining/withstanding high specific pressures and well resisting abrasion.

Hydraulic cylinder is the most loaded and critical/heavy-duty unit of press, to the high degree which are determining its performing characteristics. Therefore to construction and to the calculation of cylinder and its parts must be given the maximum of attention.

Stresses/voltages in the walls of cylinder with its support on the flange. In the walls of the cylinder, which is based on the flange, with the work radial, tangential (circular) and longitudinal stresses (Fig. 128) appear.

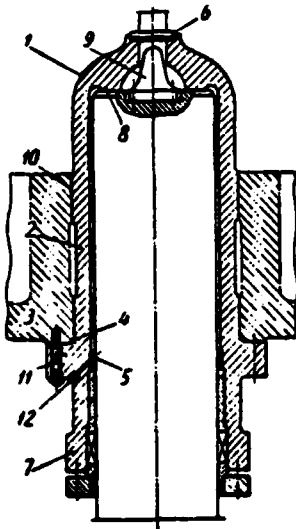

Fig. 126. Schematic of hydraulic cylinder.

Page 149.

Radial and tangential stresses have maximum value on the internal wall of cylinder and are determined from the formulas of Lamé:

$$\sigma_r = \frac{p \cdot r_1^2}{r_2^2 - r_1^2} \left(1 - \frac{r_2^2}{r^2} \right); \quad (3)$$

$$\sigma_t = \frac{p \cdot r_1^2}{r_2^2 - r_1^2} \left(1 + \frac{r_2^2}{r^2} \right). \quad (4)$$

Longitudinal stresses are equal to

$$\sigma_z = \frac{p \cdot r_1^2}{r_2^2 - r_1^2}. \quad (5)$$

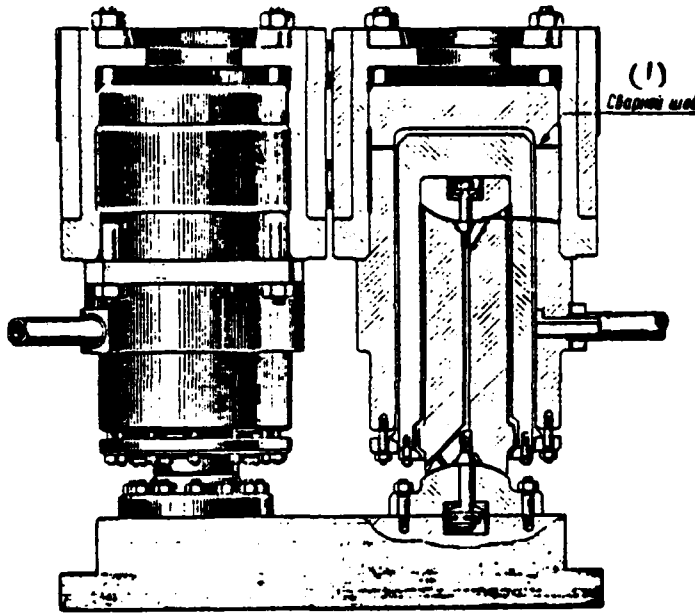

Fig. 127. Construction/design of the welded cylinder of powerful/thick hydraulic press.

Key: (1). Weld.

Page 150.

In accordance with the energy theory of strength the given voltages are equal to

$$\sigma = \sqrt{\frac{1}{2} [(\sigma_z - \sigma_r)^2 + (\sigma_t - \sigma_r)^2 + (\sigma_z - \sigma_t)^2]}; \quad (6)$$

$$\sigma_{\max} = \frac{\sqrt{3} \cdot r_2^2}{r_2^2 - r_1^2} p; \quad (7)$$

$$\sigma_{\min} = \frac{\sqrt{3} \cdot r_1^2}{r_2^2 - r_1^2} p, \quad (8)$$

where p - pressure in the cylinder in kg/cm^2 ;

r_1 - inside radius of cylinder in cm;

r_2 - outside radius of cylinder in cm;

r - radius of the filament in question in cm.

From comparison σ_{\max} and σ_{\min} it follows that with the emergence on the inside wall of the cylinder of the plastic deformation

$$\sigma_{\max} = \sigma_s = \frac{\sqrt{3} \cdot r_2^2}{r_2^2 - r_1^2} p.$$

Stresses/voltages on the external walls will be equal to

$$\sigma = \sigma_s \left(\frac{r_1}{r_2} \right)^2, \quad (9)$$

where σ_s - yield point of the material of cylinder.

Knowing the condition of the emergence of plastic deformation in the walls of cylinder and being assigned by safety factor on yield point n_s , we determine an outside radius of cylinder by the prescribed/assigned inside radius:

$$\frac{\sqrt{3} \cdot r_2^2}{r_2^2 - r_1^2} p = \sigma_\theta = \frac{\sigma_s}{n_s}, \quad (10)$$

where σ_θ — allowable stress in the walls of cylinder.

From expression (10) we obtain

$$r_2 = r_1 \sqrt{\frac{\sigma_\theta}{\sigma_\theta - \sqrt{3}p}} \quad \text{or} \quad \frac{r_2}{r_1} = \kappa = \sqrt{\frac{\sigma_\theta}{\sigma_\theta - 1.73p}}. \quad (11)$$

Value κ in different relations $\frac{\sigma_\theta}{p}$ they are given on the graph Fig. 129.

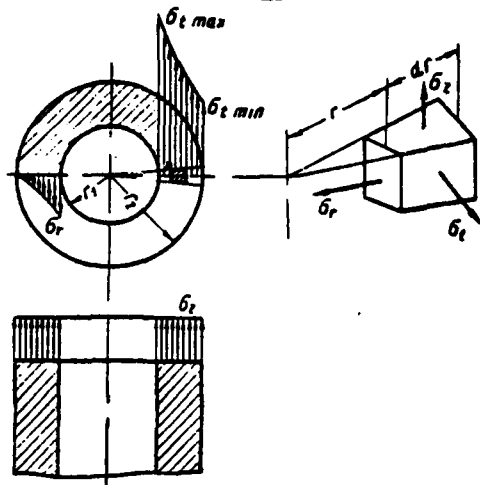

Fig. 128.

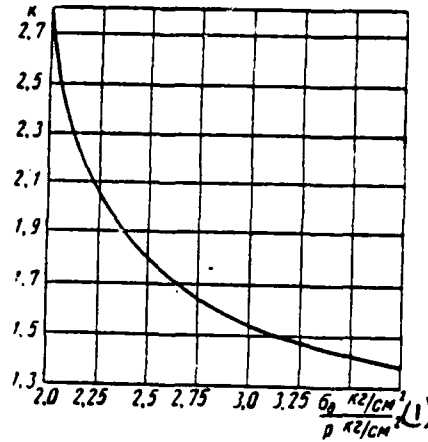

Fig. 129.

Fig. 128. Diagrams of radial, tangential and longitudinal stresses in the wall of cylinder with its support on the flange.

Fig. 129. Value r_2/r_1 in function

Key: (1). $\text{kg/cm}^2/p \text{ kg/cm}^2$.

AD-A139 822

HYDRAULIC PRESSES(U) FOREIGN TECHNOLOGY DIV
WRIGHT-PATTERSON AFB OH B V ROZANOV 09 MAR 84
FTD-ID(RS)T-1207-83

4/10

UNCLASSIFIED

F/G 13/9

NL

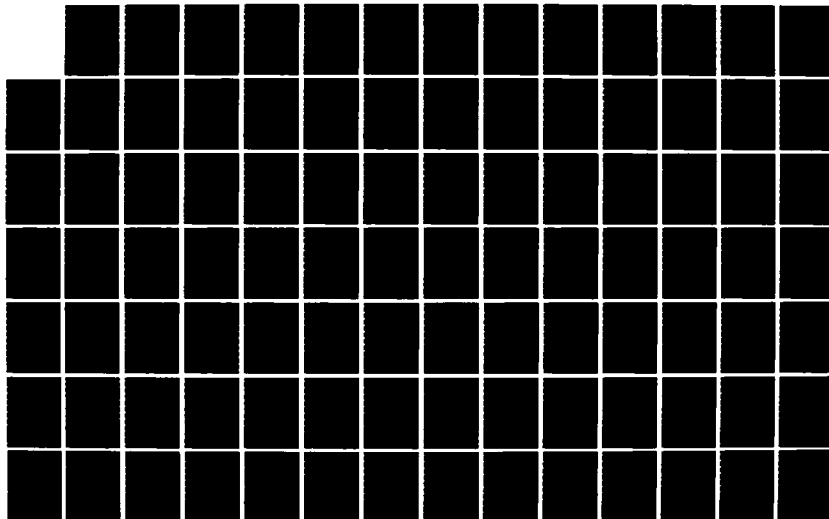

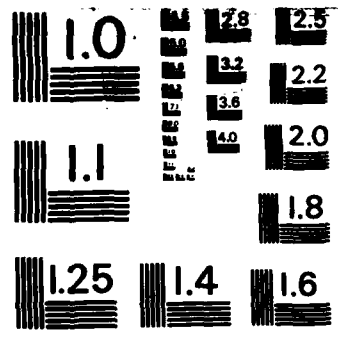

MICROCOPY RESOLUTION TEST CHART
NATIONAL BUREAU OF STANDARDS-1963-A

Page 151.

Stresses/voltages in the walls of cylinder with its support on the bottom. With the support of cylinder on the bottom longitudinal stresses in the walls of cylinder are absent, i.e., $\sigma_z = 0$.

The maximum given voltages on the internal walls of cylinder in this case are determined from the formula

$$\sigma_{\max} = \frac{\sqrt{3r_2^4 + r_1^4}}{r_2^2 - r_1^2} p. \quad (12)$$

The ratio of an outside radius of cylinder to the internal with the selected allowable stress will be equally

$$\frac{r_2}{r_1} = \kappa = \sqrt{\frac{\sigma_0^2 + p^2 \sqrt{4\sigma_0^2 - 3p^2}}{\sigma_0^2 - 3p^2}}. \quad (13)$$

Radial deformation of cylinder. The radial deformation of the based on the cylinder flange at the point, distant from the center up to distance of r , according to Lamé's formula is equal to

$$U_r = \frac{p}{E(r_2^2 - r_1^2)} r_1^2 \left[(1 - 2\mu)r + (1 + \mu) \frac{r_2^2}{r} \right]. \quad (14)$$

Radial deformations on the internal and external walls are respectively equal to

$$U_{r_1} = \frac{pr_1}{E(r_2^2 - r_1^2)} [(1 - 2\mu)r_1^2 + (1 + \mu)r_2^2]; \quad (15)$$

$$U_{r_2} = \frac{pr_1^2 r_2 (2 - \mu)}{E(r_2^2 - r_1^2)}. \quad (16)$$

For the cylinder, which is based on the bottom, radial deformation U , according to formula (14) will be more to value

$$\Delta U = \frac{r_1^2 \cdot r}{r_2^2 - r_1^2} p.$$

In the given formulas:

E - modulus of elasticity of the material of cylinder;

μ - Poisson ratio.

Selection of the material of cylinder on the prescribed/assigned pressure in the hydraulic system and the allowable stresses adopted. The trademark of steel for manufacturing the cylinder is chosen depending on planned technology of its manufacture, which is determined mainly by the sizes/dimensions of cylinder, and also by the value of the pressure adopted for the hydraulic system of press.

In many instances the decisive factor during the selection of the pressure in the hydraulic system and of material for

manufacturing the cylinder is the consideration about obtaining of the minimum value of its outside diameter (D_n).

Let us determine dependence $D_n = D_n(\sigma_\theta; \rho)$ for the cylinder, which is based on the collar.

The value of an inside radius of cylinder, expressed through the pressure of liquid (taking an inside radius of cylinder as the equal to a radius of plunger and assuming/setting the effort/force, which functions on the plunger, by the equal to one), it will be written in the form

$$r_1 = \sqrt{\frac{1}{\pi \cdot \rho}}. \quad (17)$$

Substituting in expression $D_n = 2r_1$ value of r_1 according to formula (11), we will obtain

$$D_n = 2 \sqrt{\frac{\sigma_\theta}{\pi \cdot \rho (\sigma_\theta - \sqrt{3} \cdot \rho)}}. \quad (18)$$

From this expression it follows that the optimum value of pressure, at which the outside diameter of cylinder will be minimum, corresponds to each value σ_θ .

D_n will be minimum at the maximum value of expression $\pi \cdot \rho (\sigma_\theta - \sqrt{3} \cdot \rho)$.

Differentiating this expression on p , by assuming/setting σ_0 by constant and by equalizing its value zero, we will obtain

$$p = \frac{\sigma_0}{2\sqrt{3}}; \sigma_0 = 2\sqrt{3} \cdot p \quad (19)$$

or

$$\sigma_s = 2\sqrt{3} \cdot n_s \cdot p. \quad (19')$$

Value σ_0 for the standard pressures and the character of change in the dependence on the pressure with constant σ_0 , equal to 1100 kg/cm², they are shown in Fig. 130.

From obtained dependence (19) it follows that if the pressure in the hydraulic system is selected, then for obtaining the minimum outside diameter of cylinder it is necessary to use steel, for which the allowable stress can be accepted

$$\sigma_0 > 2\sqrt{3} \cdot p \text{ or } \sigma_s > 2\sqrt{3} \cdot n_s \cdot p.$$

During the calculation of hydraulic cylinders according to Lamé's formulas it stored up strength on yield point n_s , it can be approximately accepted by 2.

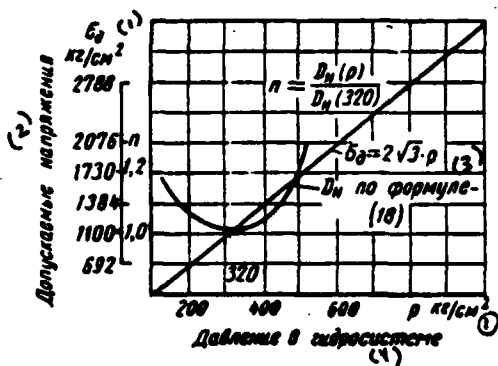

Fig. 130. Value of allowable stress at standard pressures and the character of a change of the outside diameter in the dependence on the pressure with constant

Key: (1). kg/cm². (2). Allowable stresses. (3). according to the formula. (4). Pressure in the hydraulic system.

Page 153.

In this case we obtain the following exemplary/approximate values of allowable stresses, cylinders usually adopted during the calculation: for the cast cylinders, which work at pressures 200 kg/cm² is rare with the higher, $\sigma_0 \approx 800 + 1000$ kg/cm²; for the forged cylinders, manufactured from carbon steel (0.03-9.035%C), $\sigma_0 = 1100 + 1500$ kg/cm², and made of the low-alloy steel (1.5-2% Ni) $\sigma_0 \approx 1500 + 1800$ kg/cm².

The given formulas of Lamé are valid only for the ducts/tubes/pipes with open ends, having the constant wall thickness and loaded with pressure constant along the length.

If latter/last condition (pressure constancy) for the hydraulic cylinders is satisfied, then remaining conditions do not occur. Because of this Lamé's formulas are valid only for the sections/cuts, sufficient distant from those sections, where they take place of a change in the wall thicknesses.

In the sections/cuts of cylinder, closely spaced to these sections, secondary stresses from the bend, caused by a change in the hardness of wall and diagram of loading appear; in this case, as experiments are shown, these further local stresses are commensurated with the bases.

Therefore the nose (cupola) section of the cylinder is calculated or according to the approximation formulas (with the flat bottom), or its form and sizes/dimensions of walls are chosen on the steady checked by practice standard relationships/ratios.

Stresses/voltages in the sections/cuts, closely spaced to the flange, can be with a sufficient precision/accuracy counted employing the procedure, worked out by the laboratory of forging-and-pressing

equipment TsNIITMASH.

Nose section of the cylinder (bottom). In the case of cylinder with the flat/plane bottom the thickness of the latter is determined from the formula

$$t = \sqrt{\frac{p \cdot r_1^2}{\varphi \cdot \sigma_0}}, \quad (20)$$

where φ - coefficient, which considers the weakened section/cut by hole for the supply of liquid and taken to the equal to 0.7-0.8.

Usually the thickness of flat/plane bottom is accepted equal to not less one-and-one-half wall thickness of cylinder.

Transition/transfer from the wall to bottom of cylinder must be made by the radius, equal to ~ 0.2 from the bore, but not less than 30 mm.

With accomplishing of bottom in the form of cupola a radius of the internal part of the latter is recommended to make equal to approximately $\frac{1}{3}$ cylinder bore. A radius of transition/transfer from the surface of bottom to the cylinder must be as far as possible large.

Wall thickness in the upper part of the bottom must be to 20-30% more than the wall thickness of cylinder so that the bottom, which does not yield to calculation, would not prove to be weaker than the

cylindrical part.

Stresses/voltages in the walls of cylinder, closely spaced to the flange. As research showed, local stresses from the bend have maximum value in the section/cut throughout the plane of support of flange.

Page 154.

In this section/cut secondary stresses appear not only as a result of an abrupt change in the hardness of the wall of cylinder (transition/transfer into the flange), about which it was mentioned above, but also the action of the series/row of other factors.

On their value essential effect proves to be rigidity of upper crosshead, in which the cylinder is installed. As a result of the sagging/deflection of cross-beam the redistribution of contact pressures over the bearing surface of flange occurs. In the area of the sections/cuts of cross-beam, which have the greatest hardness, the base pressures of flange sharply grow, which causes a considerable increase in the stresses/voltages in the nearest sections of the wall of cylinder.

Stresses/voltages with abrupt changes of the hardness of

cross-beam in the location of bearing flange (stiffening rib, cavity, etc.) especially strongly grow.

The considerable moment/torque, transmitted by cylinder to the cross-beam with the eccentric load, also causes the nonuniformity of the distribution of base pressures of flange, which leads to further increase in the stresses/voltages in the walls of cylinder.

Account represents great difficulties by the calculated way of the effect of all factors indicated. Therefore the procedure of calculation of stresses/voltages in the walls of the cylinder, loaded symmetrically is given below. Methodology is based on the works of S. P. Timoshenko [18].

The schematic of the loading of the cylinder of hydraulic press is schematically shown in Fig. 131. Resultant force of bearing pressure P , in the case of absolutely rigid cross-beam (axisymmetric task), will be distributed in the circle/circumference of certain radius r . The value of this radius r , in each individual case will depend on many factors, which do not yield to account in general form. Therefore we accept, that force P is applied on the periphery edge of bearing flange on radius r .

In this case the bending moment in the wall of duct/tube/pipe

from the force will be greatest; consequently, calculation will be conducted taking into account knowingly more severe conditions than are encountered in actuality.

Let us mentally cut cylinder on the upper plane of bearing flange and will consider the equilibrium of duct/tube/pipe and flange under the action of the applied external load and internal power factors. We substitute the action of the rejected/thrown part by tensile force P_u , shearing force Q and bending moment M (Fig. 132).

We accept, that force P_u evenly distributed by the cross-sectional area of duct/tube/pipe. From the conditions of the axial symmetry of task force Q has the radial direction (tangential components are absent).

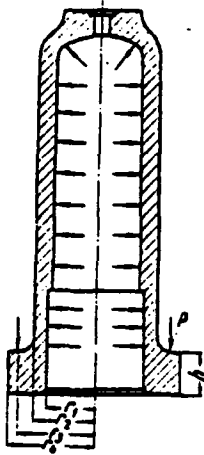

Fig. 131. Schematic of the loading of the cylinder of hydraulic press.

Page 155.

Since all power factors, which function on the cylinder, are symmetrical relative to axis/axle, then it suffices to consider the equilibrium of the strip, cut out along the generatrix of cylinder.

Let us consider the bend of the chosen strip. It is obvious, it is caused only by the action of force Q and moment/torque M . Forces P_1 and p do not give bend.

Let us separate the elementary strip with a thickness of dr and by the width, equal to 1 (Fig. 133).

If we through y designate radial displacement in any cross section of strip, then with the displacement, directed toward the center, a radius of this section/cut is shortened to value y . As a result will here occur the compressive strain in the circle/circumference and in the value, equal to

$$\epsilon_r = \frac{y}{r}. \quad (21)$$

Corresponding compressive stress will be

$$\sigma_r = E \epsilon_r = E \frac{y}{r}. \quad (22)$$

Consequently, when strip is deflected towards the axis/axle of cylinder, appear compressive forces dT , whose value, per unit of the length of strip, will be equal to

$$dT = E \frac{y}{r} dr.$$

Totaling all elementary efforts/forces dT on the height/altitude of strip, we obtain the general/common/total lateral compressive force:

$$T = \int_{r_1}^{r_2} dT = E \int_{r_1}^{r_2} \frac{y}{r} dr. \quad (23)$$

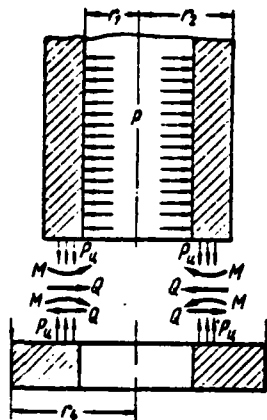

Fig. 132.

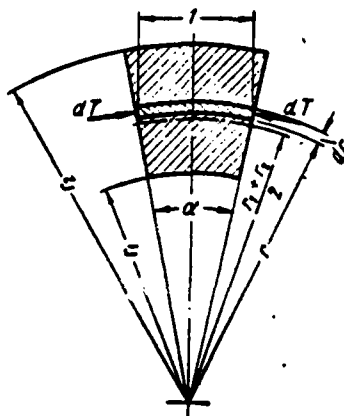

Fig. 133.

Fig. 132. Diagram of the equilibrium of duct/tube/pipe and flange under the action of forces.

Page 156.

Accepting that for the bent elementary strip the hypothesis of nonsqueezing of layers is valid, it is possible to consider value y constant for all elementary strips and to take out it as the integral sign.

Then

$$T = Ey \int_{r_1}^{r_2} \frac{dr}{r} = E \cdot y \ln \frac{r_2}{r_1}. \quad (24)$$

Since angle α is equal to $\alpha = \frac{2}{r_1 + r_2}$, then efforts/forces T give radial resultant to

$$T \cdot \alpha = \left(E \cdot y \ln \frac{r_2}{r_1} \right) \frac{2}{r_1 + r_2}. \quad (25)$$

This resultant resists the sagging of strip and is distributed along it proportional to sagging/deflection y. It is easy to note that in that case the strip is bent analogously with the beam/gully, which lies on elastic base, moreover stiffness coefficient of its

$$\kappa = E \frac{2}{r_1 + r_2} \ln \frac{r_2}{r_1}. \quad (26)$$

Any change in the form of the cross section of strip is prevented by adjacent strips in the same manner as for with the bend of plates.

Therefore the flexural rigidity of strip can be considered equal to

$$D = \frac{E t^3}{12(1 - \mu^2)} = \frac{E (r_2 - r_1)^3}{12(1 - \mu^2)}. \quad (27)$$

The differential equation of bent axle of the strip, as the beam/gully in question on the elastic support, will take the form

$$D \frac{d^4 y}{dx^4} = -\kappa y = - \left(E \frac{2}{r_1 + r_2} \ln \frac{r_2}{r_1} \right) y. \quad (28)$$

The solution of differential equation (28) is in detail presented in the work of S. P. Timoshenko ("Strength of materials", 1946, Vol. II, page 11-23) and therefore here it lowers.

Let us introduce the designation

$$\beta = \sqrt[4]{\frac{2E \ln \frac{r_2}{r_1}}{(r_1 + r_2) 4D}} \quad (29)$$

Substituting for D its value in equation (27), we obtain

$$\beta = \sqrt[4]{\frac{6(1-\mu^2)}{(r_2 + r_1)(r_2 - r_1)^3} \ln \frac{r_2}{r_1}} \quad (29')$$

Page 157.

According to accepted designations the solution of equation has the form

$$y = \frac{e^{-\beta x}}{2\beta^3 D} [\beta M_0 (\sin \beta x - \cos \beta x) - Q_0 \cos \beta x]. \quad (30)$$

This equation expresses the sagging/deflection of the wall of cylinder under the action of the shearing force of Q_0 and the bending moment M_0 , that appear in the section/cut, which passes through the upper plane of bearing flange.

Here Q_0 and M_0 - power factors, in reference to the unit of the length of the center line of cylinder.

For the solution of problem it is necessary to find values of M_0 and Q_0 , entering equation (30).

For this let us consider the deformations of cylinder and flange at the external point of cylinder together.

The linear displacement of the wall of cylinder is composed of deformation under the action of internal pressure $P - y_p$, and sagging/deflection y under the action of forces of Q and moment/torque M (effect of stretching force P_u it is considered during the use of Lamé's formulas).

According to Lamé [according to equation (16)] we have

$$y_p = p \frac{r_1^2 r_2}{E (r_2^2 - r_1^2)} (2 - \mu).$$

Substituting pressure in cylinder p through the axial force, which is transmitted by cylinder P_u ,

$$p = \frac{P_u}{\pi r_1^2},$$

we obtain

$$y_p = \frac{P_u r_2}{E \pi (r_2^2 - r_1^2)} (2 - \mu); \quad (31)$$

from equation (30) with $x=0$ it follows that

$$y_{x=0} = \frac{-1}{2\beta^2 D} (P M_0 + Q_0). \quad (32)$$

The general/common/total linear displacement of the wall of cylinder is equal

$$\Delta_u = y_p + y_{x=0} = \frac{P_u r_2 (2 - \mu)}{\pi E (r_2^2 - r_1^2)} - \frac{1}{2\beta^2 D} (\beta M_0 + Q_0). \quad (33)$$

The linear displacement of the corresponding point of flange is composed of displacement y_1 , as a result of the rotation of the section/cut of flange for the angle θ and from displacement y_2 , from the action in the section/cut of the bulging out forces of Q (Fig. 134):

$$y_1 = \frac{h}{2} \theta, \quad (34)$$

where h - height/altitude of flange.

Page 158.

Displacement y_2 , in the first approximation, can be equated to displacement from force of Q , evenly distributed over the internal surface of the hole of flange.

It is obvious,

$$Q = Q_0 \pi (r_2 + r_1).$$

We substitute the bulging out action of force of Q by the action of fictitious internal pressure by the intensity

$$q = \frac{Q}{2\pi r_1 h} = \frac{Q_0 (r_2 + r_1)}{2r_1 h}.$$

Then according to Lamé's formula (14) we have

$$y_2 = \frac{Q_0(r_2 + r_1)}{2Eh} \left(\frac{r_4^2 + r_1^2}{r_4^2 - r_1^2} + \mu \right). \quad (35)$$

The general/common/total displacement of the point of flange will be

$$\Delta_\phi = y_1 + y_2 = \frac{h}{2} \theta + \frac{Q_0(r_2 + r_1)}{2Eh} \left(\frac{r_4^2 + r_1^2}{r_4^2 - r_1^2} + \mu \right). \quad (36)$$

Equalizing the displacement of the point of cylinder to the displacement of the point of flange, we will obtain

$$\Delta_x = \Delta_\phi;$$

$$\frac{p_0 r_2 (2 - \mu)}{\pi E (r_2^2 - r_1^2)} - \frac{1}{2\beta^2 D} (\beta M_0 + Q_0) = \frac{h}{2} \theta + \frac{Q_0(r_2 + r_1)}{2Eh} \left(\frac{r_4^2 + r_1^2}{r_4^2 - r_1^2} + \mu \right). \quad (37)$$

The angle of rotation of cylinder in section/cut $x=0$ must be equal to the angle of rotation of flange θ :

$$\theta_x = \theta.$$

It is obvious that forces p_0 and p do not cause rotation.

Consequently, according to equation (30)

$$\theta_x = \left(\frac{dy}{dx} \right)_{x=0}.$$

Differentiating equation (30) and assuming/setting $x=0$, we

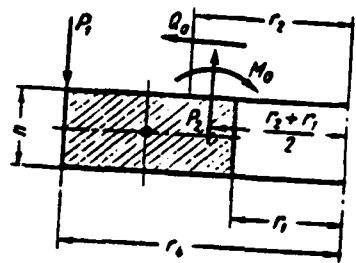

Fig. 134.

obtain

$$\theta_0 = \frac{1}{2\pi^2 D} (2\beta M_0 + Q_0) = \theta. \quad (38)$$

Page 159.

For determining the angle of rotation of flange θ we will use formula for twisting the annulus (Timoshenko S. P. "Strength of materials", Vol. II, 1946, page 165):

$$\theta = \frac{6M_t (r_2 + r_1)}{Eh^3 \ln \frac{r_2}{r_1}}, \quad (39)$$

where M_t — torsional moment, per unit of the length of the center line of flange.

Examining the forces, which function on the flange (Fig. 134), it is possible to see that

$$M_t = \frac{P_4 (r_2 - r_1)}{2\pi (r_2 + r_1)} + \frac{Q_0 h (r_2 + r_1)}{2 (r_2 + r_1)} + \frac{P_4 (r_2 - r_1)}{2\pi (r_2 + r_1)} - M_0 \frac{r_2 + r_1}{r_2 + r_1}.$$

Then

$$\theta = \frac{6 (r_2 + r_1)}{Eh^3 \ln \frac{r_2}{r_1}} \left[P_4 \frac{1}{\pi} \left(\frac{r_2}{r_1 + r_2} - \frac{1}{2} \right) + Q_0 \frac{h}{2} - M_0 \right]. \quad (40)$$

Thus, we have three equations (37), (38) and (40), into which three unknowns M_0 , Q_0 , θ enter.

Solving this system of equations, let us find values M_0 and Q_0 .

Let us rewrite these equations in the form

$$\left. \begin{aligned} \left[\frac{r_2 + r_1}{2Eh} \left(\frac{r_2^2 + r_1^2}{r_2^2 - r_1^2} + \mu \right) + \frac{1}{2\beta^2 D} \right] Q_0 + \frac{1}{2\beta^2 D} M_0 + \frac{h}{2} \theta &= \\ &= \frac{P_4 r_2}{\pi E (r_2^2 - r_1^2)} (2 - \mu); \\ \frac{1}{2\beta^2 D} Q_0 + \frac{1}{\beta D} M_0 - \theta &= 0; \\ -\frac{h}{2} Q_0 + M_0 + \frac{Eh^3}{6(r_2 + r_1)} \ln \frac{r_2}{r_1} \theta &= P_4 \frac{1}{\pi} \left(\frac{r_2}{r_2 + r_1} - \frac{1}{2} \right). \end{aligned} \right\} (41)$$

Page 160.

Let us introduce the designations:

$$a_1 = \frac{r_2 + r_1}{2Eh} \left(\frac{r_2^2 + r_1^2}{r_2^2 - r_1^2} + \mu \right) + \frac{1}{2\beta^2 D};$$

$$a_2 = \frac{1}{2\beta^2 D};$$

$$a_3 = -\frac{h}{2};$$

$$b_1 = \frac{1}{2\beta^2 D};$$

$$b_2 = \frac{1}{\beta D};$$

$$b_3 = 1;$$

$$c_1 = \frac{h}{2};$$

$$c_2 = -1;$$

$$c_3 = \frac{Eh^3}{6(r_2 + r_1)} \ln \frac{r_2}{r_1};$$

$$d_1 = P_4 \frac{r_2}{\pi E (r_2^2 - r_1^2)} (2 - \mu);$$

$$d_2 = 0;$$

$$d_3 = P_4 \frac{1}{\pi} \left(\frac{r_2}{r_2 + r_1} - \frac{1}{2} \right).$$

Then system of equations (41) can be rewritten in the form

$$\left. \begin{aligned} a_1 Q_0 + b_1 M_0 + c_1 \theta &= d_1; \\ a_2 Q_0 + b_2 M_0 + c_2 \theta &= d_2; \\ a_3 Q_0 + b_3 M_0 + c_3 \theta &= d_3. \end{aligned} \right\} \quad (41')$$

Hence values M_0 and Q_0 are expressed in the form

$$M_0 = \frac{\begin{vmatrix} a_1 d_1 c_1 \\ a_2 d_2 c_2 \\ a_3 d_3 c_3 \end{vmatrix}}{\begin{vmatrix} a_1 b_1 c_1 \\ a_2 b_2 c_2 \\ a_3 b_3 c_3 \end{vmatrix}} = m P_u; \quad (42)$$

$$Q_0 = \frac{\begin{vmatrix} d_1 b_1 c_1 \\ d_2 b_2 c_2 \\ d_3 b_3 c_3 \end{vmatrix}}{\begin{vmatrix} a_1 b_1 c_1 \\ a_2 b_2 c_2 \\ a_3 b_3 c_3 \end{vmatrix}} = q P_u; \quad (43)$$

After determining M_0 and Q_0 , it is possible to rewrite equation (30) in the form

$$y = P_u \frac{e^{-\beta x}}{2\beta^2 D} [2m (\sin \beta x - \cos \beta x) - q \cos \beta x]. \quad (44)$$

Here m and q - the completely specific values [see equations (42) and (43)] and this equation wholly solves assigned mission about the account of the effect of flange on the redistribution of stresses/voltages in the walls of cylinder.

Page 161.

It is interesting to note that equation (44) determines by itself the rapidly damped wavy curve with the wavelength, equal to

$$l = \frac{2\pi}{\beta} = 2\pi \sqrt{\frac{(r_2 + r_1)(r_2 - r_1)^2}{6(1 - \mu^2) \ln \frac{r_2}{r_1}}} \quad (45)$$

This wave attenuates virtually completely with $x = (1.5-2) r_2$, which confirms the possibility to use Lamé's formulas for the sections, distant from the flange (and from the bottom) up to the distance

$$x > (1.5 + 2) r_2.$$

Let us switch over to the determination of the stresses/voltages, which appear in the walls of cylinder.

The stressed state in the wall of pressure cylinder can be represented as the imposition of the stresses/voltages, which appear in the elementary strip under the action of force Q_0 and moment/torque M_0 , to the stresses/voltages, which appear in the ordinary thick-walled cylinder, which is loaded with internal pressure.

Consequently, stress/voltage at any point of wall can be expressed as the sum of two values

$$\sigma = \sigma_M + \sigma_{M_0}; Q_0'$$

where σ - stress/voltage at the point in question;

σ_M - stress/voltage, calculated by the formulas of Lamé;

$\sigma_{M, Q}$ - stress/voltage, which appears as a result of action M , and Q .
(or, which is one and the same, M and Q).

Further conclusions depend on the sign of values m and q , computed from formulas (42) and (43); in this case the sign of value m , which is determining the direction of the bending moment, is most important. With those relationships/ratios of the sizes/dimensions of cylinder and flange, which are encountered in the practice, value m , as a rule, proves to be positive, i.e., the bending moment M , has a direction, indicated in Fig. 134.

We accept for further considerations, that values m and q are positive. If during the calculation of concrete/specific/actual cylinder by one of them or both will prove to be negative in the appropriate formulas will have to only change sign to the reverse/inverse.

Let us consider stresses/voltages on the external filament of

cylinder.

Is obvious, radial stress

$$\sigma_r = 0; \quad (46)$$

longitudinal stress

$$\sigma_z(r_2) = \sigma_z(r_2) \pi + \sigma_z(r_2) M, \quad (47)$$

where $\sigma_z(r_2) \pi = \frac{P_4}{\pi(r_2^2 - r_1^2)}$ according to equation (5);

$\sigma_z(r_2) M$ - stress/voltage in the external filament of cylinder, caused by the bend of wall.

Page 162.

Examining the bend of strip (Fig. 133), isolated from the cylinder, it is possible to register

$$\sigma_z(r_2) M = \frac{6M}{(r_2 - r_1)^2}. \quad (48)$$

where M - bending moment in the section/cut in question.

The bending moment M can be determined from the equation

$$D \frac{d^2 y}{dx^2} = -M.$$

Twice differentiating equation (30) and producing the appropriate calculations, we obtain

$$M = e^{-\beta x} \left[M_0 \cos \beta x + \left(M_0 + \frac{Q_0}{\beta} \right) \sin \beta x \right]. \quad (49)$$

or substituting M_0 and Q_0 according to formulas (42) and (43) through mP_0 and qP_0 , we will obtain

$$M = P_0 e^{-\beta x} \left[m \cos \beta x + \left(m + \frac{q}{\beta} \right) \sin \beta x \right]. \quad (50)$$

Substituting expression for M from equation (50) into equation (47) and writing/recording $\sigma_{z(r_1)}$ according to equation (6), we will obtain finally

$$\sigma_{z(r_1)} = P_0 \left\{ \frac{1}{\pi (r_2^2 - r_1^2)} + \frac{6e^{-\beta x}}{(r_2 - r_1)^3} \left[m \cos \beta x + \left(m + \frac{q}{\beta} \right) \sin \beta x \right] \right\}. \quad (51)$$

The bend of strip causes also tangential stresses in the walls of cylinder. Tangential stresses are composed of two parts:

1. The stresses/voltages, which prevent the cross sections of strip from the distortion of their form; the maximum value of these stresses/voltages it is equal to

$$\sigma'_t = \mu \sigma_{zm} = \frac{6\mu M}{(r_2 - r_1)^3}. \quad (52)$$

2. The stresses/voltages, which appear as a result of the shortening of the length of a layer in the circle/circumference as a result of decreasing the radius of a layer for value y :

$$\sigma'_t = + \frac{E}{r} y. \quad (53)$$

where r - radius of the filament in question;

y - is determined by formula (30).

Total tangential stresses in the external filament will be equal to

$$\sigma_t(r_2) = \sigma_t(r_2)_{II} + \sigma_t' + \sigma_t''.$$

According to Lamé's formula

$$\sigma_t(r_2)_{II} = 2p \frac{r_1^2}{r_2^2 - r_1^2} = \frac{2P_4}{\pi (r_2^2 - r_1^2)}. \quad (54)$$

Page 163.

Using equations (52), (53), (50) and (44), we obtain

$$\begin{aligned} \sigma_t(r_2) = P_4 \left\{ \frac{2}{\pi (r_2^2 - r_1^2)} + \frac{E}{2\beta^2 D r_2} e^{-\beta x} [\beta m (\sin \beta x - \cos \beta x) - q \cos \beta x] + \right. \\ \left. + \frac{6\mu}{(r_2 - r_1)^2} e^{-\beta x} \left[m \cos \beta x + \left(m + \frac{q}{\beta} \right) \sin \beta x \right] \right\}. \quad (55) \end{aligned}$$

For most dangerous, as a rule, section/cut $x=0$ (section/cut throughout the plane of support of flange) of formula (46), (51) and (55) they give

$$\left. \begin{aligned} \sigma_{r_2} &= 0; \\ \sigma_x(r_2) &= P_4 \left[\frac{\sigma_{r_1}}{\pi (r_2^2 - r_1^2)} + \frac{6m}{(r_2 - r_1)^2} \right]; \\ \sigma_t(r_2) &= P_4 \left[\frac{2}{\pi (r_2^2 - r_1^2)} - \frac{E}{2\beta^2 D r_2} (\beta m + q) + \frac{6\mu m}{(r_2 - r_1)^2} \right]. \end{aligned} \right\} \quad (56)$$

Let us consider stresses/voltages on the internal surface. Since

when deriving the equation for the bend of strip the hypothesis of nonsqueezing of layers, stress/voltage σ_r , was accepted it is possible to determine from the common formula of Lamé (3).

Special stress/voltage on the internal filament is determined by the formula, analogous to formula (47):

$$\sigma_{z(r_1)} = \sigma_{z(r_1)M} - \sigma_{z(r_1)M}$$

For internal filament $\sigma_{z(r_1)M}$ according to equation (6) it is equal

$$\sigma_{z(r_1)M} = \frac{P_4}{\pi (r_2^2 - r_1^2)}$$

Computing $\sigma_{z(r_1)M}$ analogous with equations (48), (49) and (51), we will obtain

$$\sigma_{z(r_1)} = P_4 \left\{ \frac{1}{\pi (r_2^2 - r_1^2)} - \frac{6e^{-\beta x}}{(r_2 - r_1)^2} \left[m \cos \beta x + \left(m + \frac{q}{\beta} \right) \sin \beta x \right] \right\}. \quad (57)$$

Tangential stress on the internal filament can be registered analogously with equations (52), (53), (54) and (55):

$$\sigma_{\theta(r_1)} = P_4 \left\{ \frac{(r_2^2 + r_1^2)}{\pi r_1^2 (r_2^2 - r_1^2)} + \frac{E}{2\beta^2 D r_1} e^{-\beta x} [\beta m (\sin \beta x - \cos \beta x) - q \cos \beta x] - \frac{6\mu}{(r_2 - r_1)^2} e^{-\beta x} \left[m \cos \beta x + \left(m + \frac{q}{\beta} \right) \sin \beta x \right] \right\}. \quad (58)$$

In most critical section/cut ($x=0$) axial and tangential stresses on the internal filament will be equal to

$$\sigma_z(r_1) = P_u \left[\frac{1}{\pi(r_2^2 - r_1^2)} - \frac{6m}{(r_2 - r_1)^2} \right];$$

$$\sigma_t(r_1) = P_u \left[\frac{r_2^2 + r_1^2}{\pi r_1^2 (r_2^2 - r_1^2)} - \frac{E}{2\beta^2 D r_1} (\beta m + q) - \frac{6\mu m}{(r_2 - r_1)^2} \right]. \quad (59)$$

In order to more precisely determine the most critical section/cut, it is necessary to compute the value of equivalent stress/voltage according to one of the theories of strength [for example, on the energy (7)] for the external and inner cylinder faces.

Without large error it is possible to consider that section/cut $x=0$ is the most critical section/cut.

The emergence of the internal power factors: the bending moment M and the shearing force Q is determined, in the first place, by the ability of flange to be widened under the action of the shearing force (by its pliability/compliance in the radial direction) and, in the second place, by its hardness for the torsion.

The greater the hardness, the less the bending moment from the bearing pressure, transmitted to the walls of cylinder. Consequently, with designing should be attained the greatest torsional rigidity of

flange.

The nearer the pliability/compliance of flange in the radial direction to the pliability/compliance of cylinder itself, the less the shearing force and the bending moment. It is desirable therefore to provide maximum pliability/compliance to flange. From this point of view optimum is the use of a flange on the possibility of smaller diameter (minimum radius r_1) with sufficient to its large height/altitude.

An outside radius of flange in this case must be determined from the permissible crumpling stress of the bearing surfaces of flange and upper cross-beam:

$$\frac{P_4}{\pi (r_1^2 - r_2^2)} = \sigma_{\text{dcm}}$$

Should be assumed equal bearing stress σ_{dcm} 800-1000 kg/cm².

Height of flange must be accepted depending on the thickness of the wall of the cylinder of the equal to

$$h \approx 1,5(r_2 - r_1) \approx 1,5t \text{ (Fig. 135)}$$

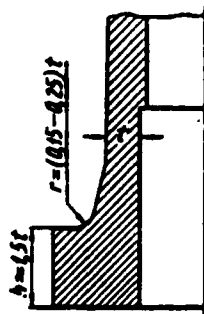

Fig. 135. View of thickening of cylinder wall with transition to a flange.

Page 165.

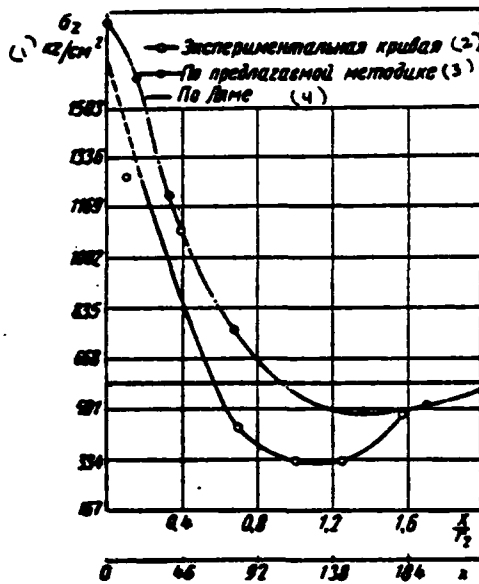

Fig. 136.

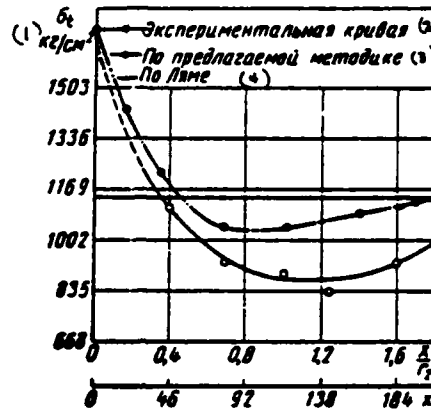

Fig. 137.

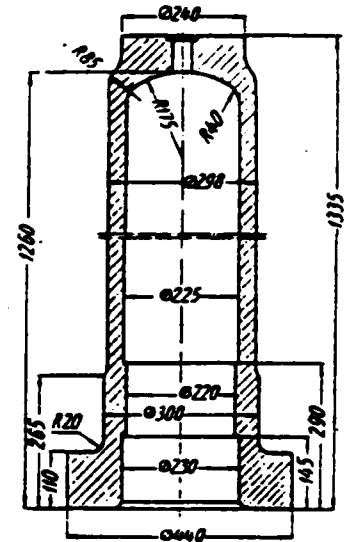

Fig. 138.

Fig. 136. Longitudinal stresses in the walls of the cylinder (see Fig. 138).

Key: (1). kg/cm². (2). Experimental curve. (3). Employing the proposed procedure. (4). According to Lamé.

Fig. 137. Tangential stresses in the machine tools of the cylinder (see Fig. 138).

Key: (1). kg/cm². (2). Experimental curve. (3). Employing the

proposed procedure. (4). According to Lamé.

Fig. 138. The longitudinal section of pressure cylinder.

Page 166.

To avoid stress concentration in the angles, formed by the external wall of cylinder and by the surface of flange, these angles must be rounded off by the radii, equal (approximately)

$$r = (0.15 - 0.25) t.$$

In order to guarantee the necessary strength of cylinder in the sections/cuts throughout the bearing flange, the wall of cylinder with the approach to the flange is frequently made somewhat larger thickness than calculated (see Fig. 135).

Calculations, employing procedure presented above, stresses/voltages in the wall of cylinder were repeatedly checked experimentally and in this case the satisfactory agreement of calculated and experimental data was observed. As an example Fig. 136 and 137 give the graphs of stresses/voltages, obtained by calculation and measurement with the help of the resistance strain gauges for the cylinder, construction/design and sizes/dimensions of which are shown

in Fig. 138.

PLUNGERS.

The plunger of hydraulic cylinder transmits effort for the crosshead and, thus, works on the compression. With the eccentric loading of press the plunger further is loaded by the moment/torque, whose value depends on the joint design of plunger with the cross-beam. There are three in principle distinct constructions/designs of this compound: rigid - framing of plunger in the cross-beam (see Fig. 16), the compound through the spherical bearing (see Fig. 43) and the compound through the pestle with ball ends of the low radius (see Fig. 127). With the first, rigid connection the plunger tests/experiences the greatest loading from the moment/torque, which appears with the eccentric loading of press. In other two cases the plunger is loaded by moment/torque from forces of friction; in this case the value of moment/torque is less, the less the radius of support.

According to the conditions of loading of plunger the transmission of load on the cross-beam through the pestle is the best version. However, this performance is difficultly realized in the plungers of low diameter. In the three-cylinder press, with respect to conditions of installation, rigid attachment is admissible only

for the average/mean plunger.

Besides a sufficient strength of plunger, high hardness and purity/finish of the treatment of its working surface (grindings) is basic requirement, since from these qualities to a considerable degree the wear of cylinder sealings/packings/compactions and guiding and pressure bushings of cylinder depends.

Plungers usually manufacture forged from the carbon steel with content of 0.6-0.8% of carbon and having limit strength 60-70 kgf/mm².

Working ram area must have a hardness $H_s = 35 \div 40$.

The plungers, filled up rigidly into the cross-beam and workers under the severe conditions, frequently manufacture from alloy chrome-nickel and chrome-molybdenum steel; the hardness of the working surface of such plungers comprises $H_s = 65 \div 85$.

Page 167.

In the stamping, and sometimes also in the forging presses are applied also cast iron plungers. They are cast into metal molds; therefore their surface is obtained with chilled layer, which has

$$H_s = 55 \div 75.$$

hardness Λ They designate the thickness of the chilled layer, depending on the diameter of plunger, by the equal to 15-40 mm. With the large thickness of the chilled layer the bending strength of plunger is depressed. The exemplary/approximate chemical composition of solid cast iron plungers with the chilled surface is the following: 3.0-3.5% C; 0.6-0.7% Mn; 0.7-0.8% Si; not more than 0.15% S and not more than 0.6% P.

Plungers are frequently made by hollow ones with the internal cavity, converted to the cylinder. In this case one should cavity leave opened (not to place silencer/plug). In this case foreign particles, available in the working fluid, settle on the bottom of the cavity of plunger and do not fall on its working surface and sealings/packings/compactions. The latter with this less are worn.

CALCULATION OF THE MOUNTINGS OF CORNER POST-TYPE PRESSES.

Design concepts of presses. The performance of the mounting of press with four columns is most widely used and is applied for the forging presses with forces from 500 to 15000 t, for the stamping and blanking machines by efforts/forces to 20000 t, and also for other presses of different designation/purpose.

The places of application and the value of forces and

moments/torques of those functioning on the mounting of press, depend on the technological performance of construction/design, and also on the loading of press.

The realized fundamental design concepts of corner post-type presses are given in Fig. 139-143.

In the basis of the selection of diagrams as standard for the calculation, is placed only sign/criterion - loading of the frame of press (without taking into account friction in the heels of plungers).

On the diagrams Fig. 139 and 140 moment/torque from the eccentric application of force to cross-beam $M_p = P \cdot e_1$, if we consider plunger or stem of the crosshead sufficiently rigid, completely is transmitted to the upper cross-beam. By the diagrams Fig. 141 and 142 moment/torque M_p is transmitted in the form of the horizontal forces, which function on the columns. On the diagrams Fig. 143 and 144 moment/torque M_p is balanced by the force, which functions on the upper cross-beam through the stem of the crosshead.

However, taking into account forces of friction in the heels and the deformation of columns all diagrams are led to one design diagram with load factors different in the value.

The assumptions adopted and the designation of values. The mounting of corner post-type press is the closed statically indeterminable three-dimensional/space frame with with many the unknowns, loaded unsymmetrically applied forces and moments/torques.

Page 168.

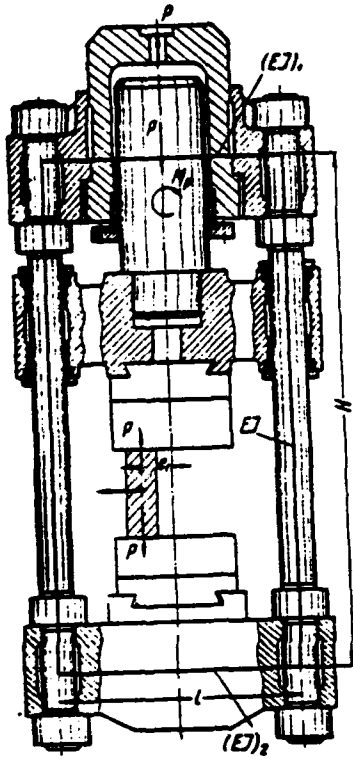

Fig. 139.

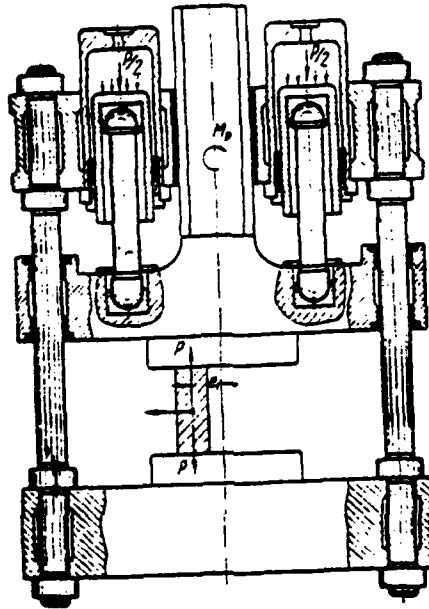

Fig. 140.

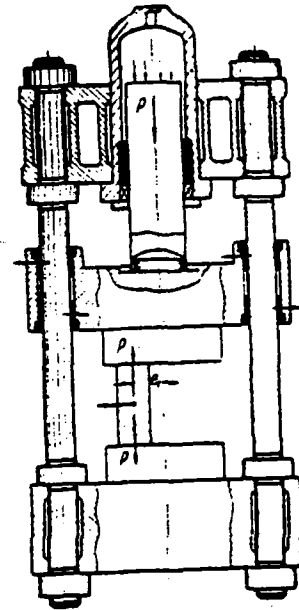

Fig. 141.

Page 169.

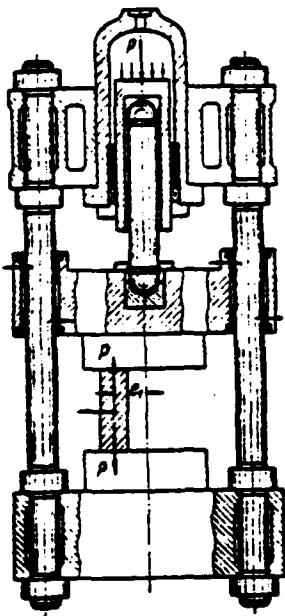

Fig. 142.

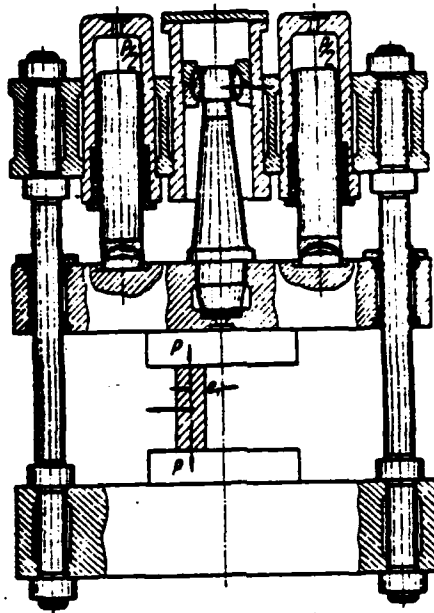

Fig. 143.

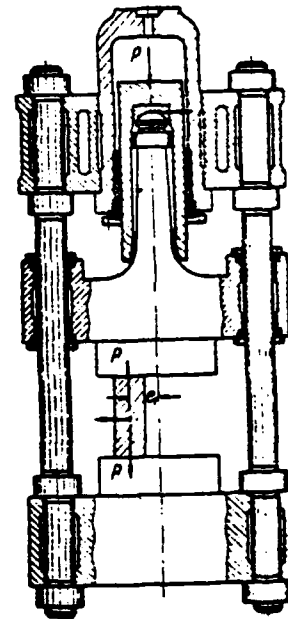

Fig. 144.

Page 170.

The solution of this problem presents great difficulties not only as a result of a large number of the statically indeterminable power factors, but also as a result of the complicated construction/design of the elements/cells of frame (upper and lower cross-beam, etc.), of dependence of the loading of mounting on the value and the nonuniformity of clearances in the plunger guide and the crosshead, the nonuniformity of the tightening of the columns and other factors.

Calculation procedure with the following adopted assumptions is given below: three-dimensional/space frame is substituted by flat/plane; columns are assumed to be those rigidly sealed in the upper and lower cross-beams; effort/force from the cylinders with the bearing flange is transmitted to the upper cross-beam in the form of force couple, applied in the centers of gravity of supporting/reference half-flanges (Fig. 145).

In the case of the support of cylinder to the bottom the effort/force, transmitted by the cylinder, can be accepted concentrated or evenly distributed.

Efforts from the plungers for the crosshead are accepted in the form of concentrated forces. Effort for lower cross-beam is transmitted in the form of the load, evenly distributed at the length, the equal to $2/3$, effective span between the centers of columns.

Pressure from the crosshead on the columns is distributed according to the law of the triangle, which is substituted by the concentrated force, applied in the center of gravity of triangle.

The hardness of the plates/slabs, installed on the lower cross-beam and the crosshead, in the calculation is not considered. The thermal stresses, which appear during the work during forging or stamping the hot blanks are not considered also. Upper and lower cross-beams are substituted by bars with the fixed time of inertia along the length.

In such a case, when the hardness of upper and lower cross-beams sharply vary along the length, is produced the averaging of their moments of inertia, on the basis of the condition, so that the given moments of inertia would provide the same angle of rotation of columns in the framing, as in the case of real cross-beams.

For this we enter as follows. We accept, that the hardness of cross-beams so exceeds the hardness of columns that crossheads can be considered as beams/gullies on two supports. For this beam/gully under the action of power load we define the angle of rotation ϕ of hinged section/cut as the function of the moment of inertia. We construct the moment diagram and graphs/curves of a change in the moment of inertia in the cross-beam.

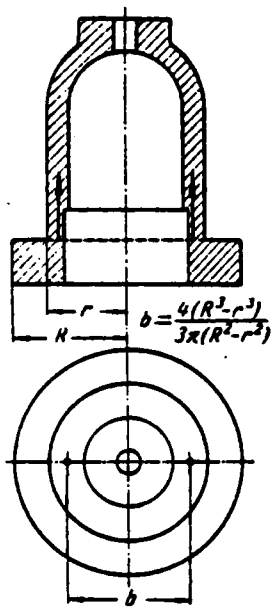

Fig. 145.

Page 171.

We divide/mark off both graphs into n sections, neutralize bending moments M_i and moments of inertia J_i in each section and, after leading the summation of expressions, we obtain

$$\varphi = \sum_{i=1}^n \frac{M(i) \Delta x_i}{E J_i}$$

where Δx_i — length of section. Equalizing both expressions for φ , we find the given moment of inertia. Summation is conducted for one half of cross-beam. The hardness of the crosshead in this case is taken as the equal to infinity. Other unstipulated assumptions are clear from

the design diagrams accepted.

During the determination of saggings/deflections the normal and shearing forces are not considered.

In the subsequent calculations we accept the following designations (see Fig. 139):

P - effort/force, developed with press, in kg;

H - height/altitude of frame, equal to the distance between the neutral axes/axles of upper and lower cross-beams in cm;

l - width of frame, equal to the distance between centers of columns, in cm;

e_1 - eccentricity of the load application in cm;

EJ - flexural rigidity of column in kg/cm^2 ;

$(EJ)_1$ - flexural rigidity of upper cross-beam in kg/cm^2 ;

$(EJ)_2$ - flexural rigidity of lower cross-beam in kg/cm^2 ;

$$\frac{EJ}{(EJ)_1} = \kappa_1;$$

$$\frac{EJ}{(EJ)_2} = \kappa_2.$$

Moments/torques from forces of friction and reaction in the heels of plungers. Plunger with the pestle (Fig. 146). Moment/torque from forces of friction in five

$$m \approx P\mu r + \mu \frac{mr}{L},$$

where μ - coefficient of friction,

$$m \approx \frac{\mu r P}{1 - \mu \frac{r}{L}} \approx \mu r P. \quad (60)$$

Reaction in the support

$$N = \frac{m}{L} = \frac{\mu r P}{L - \mu r} \approx \frac{\mu r P}{L}. \quad (61)$$

Plunger with the spherical fifth (Fig. 147). Moment/torque from forces of friction in spherical five

$$m \approx \mu Pr + \mu^2 Pr = \mu Pr (1 + \mu). \quad (62)$$

Page 172.

Resisting force to displacement of the support

$$N \approx \mu P. \quad (63)$$

Design diagram. Let us consider the most general/most common/most total design concept of press with the plunger, which has pestle (Fig. 148).

To the crosshead of press the forces function and the moments/torques, shown in Fig. 149.

Equations of the static equilibrium of the cross-beam:

$$T_1 + T_3 - T_2 - T_4 + \frac{N}{2} - T = 0; \quad (64)$$

$$\frac{Pe_1}{2} - \frac{M}{2} - \frac{N}{2} h_6 - (T_1 + T_3) h_6 + (T_2 + T_4) (h_4 - a) = 0. \quad (65)$$

To the frame of press the forces function and the moments/torques, shown in Fig. 150. Equation of the static equilibrium of the frame:

$$\frac{Pe_1}{2} + \frac{M}{2} + Th_3 - \frac{N(H+h_6)}{2} - (T_1 + T_3) h_1 + (T_2 + T_4) h_2 = 0.$$

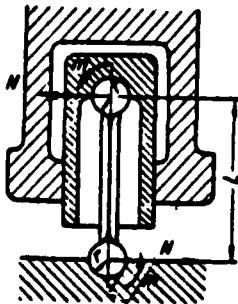

Fig. 146.

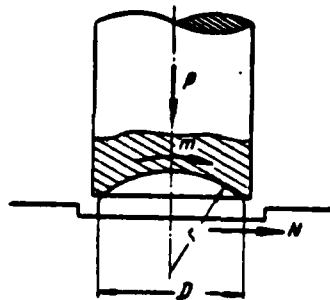

Fig. 147.

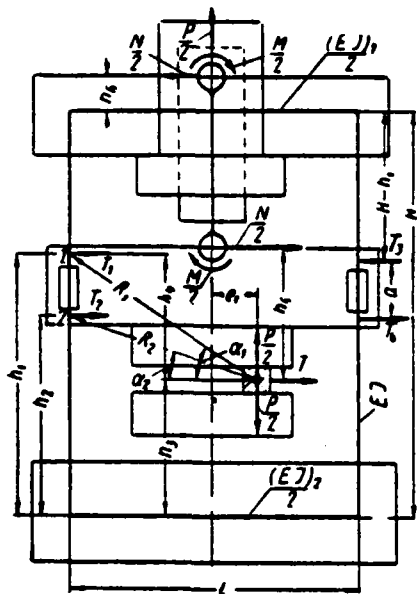

Fig. 148.

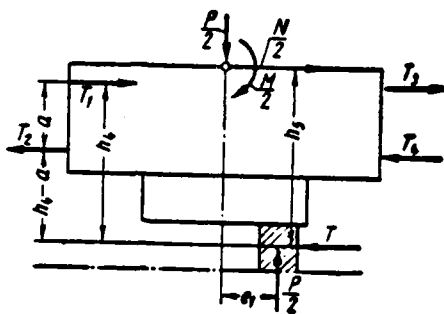

Fig. 149.

Page 173.

The written equation is identical to equation (65).

In equations (64) and (65) we have five unknowns:

$$T_1; T_2; T_3; T_4; T.$$

For simplification in the task let us take $T_1=T$, and $T_2=T$, and, thus, let us reduce a number of unknowns up to three.

The missing equation we will obtain from the approximate relationship/ratio of displacements under the action of forces of $T_1(T_1)$ and $T_2(T_2)$.

Let us preliminarily write the dependence of horizontal displacement on the angle of rotation for the point of absolutely rigid body (Fig. 151).

Let during the rotation of body to the angle θ point D move into position E.

The horizontal displacement BC will be equally

$$BC = AC - AB = R [\cos \alpha - \cos (\alpha + \theta)];$$

$$AC = AO - OE \cos (\alpha + \theta) = R [1 - \cos (\alpha + \theta)];$$

$$AB = R (1 - \cos \alpha).$$

Expanding in the Taylor series the trigonometric functions

$$\cos \alpha \quad (1) \quad \cos (\alpha + \theta)$$

$$\cos x = 1 - \frac{x^2}{2!} + \frac{x^4}{4!}$$

Key: (1). and.

and being limited by the first three members, considering in this case θ^2 the small higher-order quantity, we obtain

$$\begin{aligned} \cos \alpha - \cos (\alpha + \theta) &= 1 - \frac{\alpha^2}{2!} + \frac{\alpha^4}{4!} - 1 + \frac{(\alpha + \theta)^2}{2!} - \frac{(\alpha + \theta)^4}{4!} = \\ &= \theta \left(\alpha - \frac{\alpha^3}{3!} \right). \end{aligned} \quad (66)$$

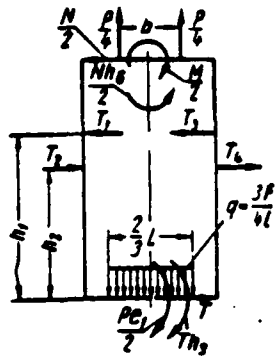

Fig. 150.

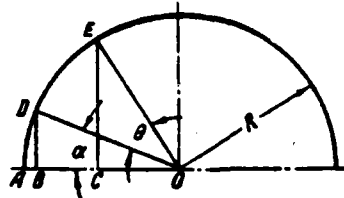

Fig. 151.

Page 174.

Then the relation of the horizontal displacements of points under forces of T_1 and T_2 will equal

$$\frac{\Delta_1}{\Delta_2} = \frac{\left(a_1 - \frac{a_1^3}{3I}\right)R_1}{\left(a_2 - \frac{a_2^3}{3I}\right)R_2} = \psi_1.$$

Let us determine displacements Δ_1 and Δ_2 , solving system on Fig. 150 by method, presented below.

For some design concepts of press, for example for the diagram, shown in Fig. 143, the force which functions on the upper cross-beam, is statically indeterminable, and in this case further equation for determining this force is necessary.

Analogous with the case dismantled/selected previously (see Fig. 150), this equation can be obtained by the writing of the ratio of the horizontal displacement of upper cross-beam to the horizontal displacement of column at the point of application of one of the forces, which function on the columns. If we take the crosshead of absolutely rigid, then this relation becomes the constant value,

which depends only on the sizes/dimensions of frame, the crosshead and the vertical position of the latter:

$$\frac{\Delta_2}{\Delta_1} = \psi_2.$$

Value ψ_2 is also determined according to diagram in Fig. 152 and takes the form

$$\psi_2 = \frac{\left(a_2 - \frac{a_3^3}{3!}\right) R_2}{\left(a_1 - \frac{a_1^3}{3!}\right) R_1}.$$

For simplification in the calculations, for the purpose of obtaining the completed expressions for the power factors and the displacements under forces of T_1 and T_2 , let us divide the diagram, shown in Fig. 150, into four elementary structure diagrams (Fig. 153).

Let us consider the central loading (Fig. 153a) for one- and two-cylinder presses. The solution for the three-cylinder press can be obtained by the summation of the solutions for one- and two-cylinder presses.

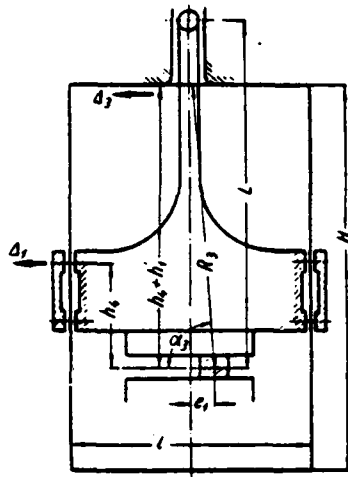

Fig. 152.

Page 175.

In the case two- and three-cylinder presses loading by moment/torque M with force N of upper cross-beam for the simplification we lead to the schematic of single-cylinder press.

The loading of columns by transverse forces let us consider in the following cases:

- 1) with the uniform loading of all four columns by force couples
- 2) with the loading by the force couples only of two columns;

3) in the case of the bursting open of left columns by forces T_1 and of the right - by forces T_2 .

Central loading - single-cylinder press. For disclosing/expanding the static indefinability of this system (Fig. 154) we cut into three hinge joints at points 3, 4 and 5.

During the determination of moments/torques x_1 and x_2 , which appear in the hinge joints, we use a method of canonical equations (Fig. 155).

The diagrams/curves of the bending moments from the external load, from moments/torques x_1 and x_2 in the basic system are shown in Fig. 156.

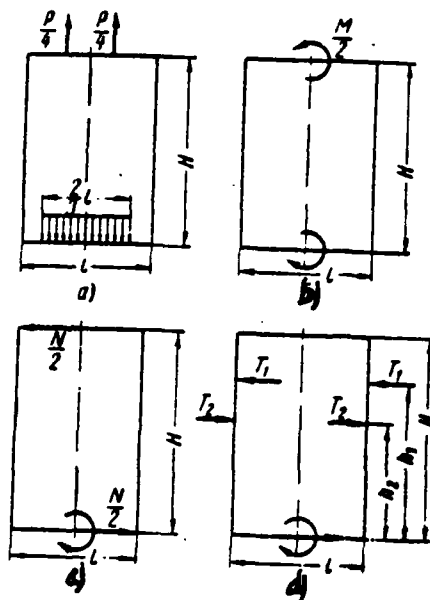

Fig. 153.

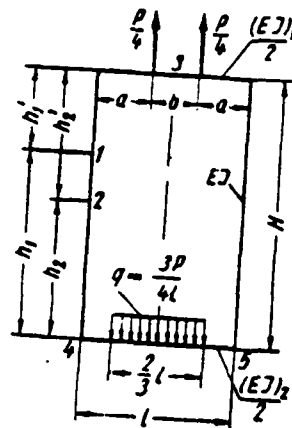

Fig. 154.

Fig. 153. Distribution of the diagram of loading (Fig. 150) into the elementary diagrams: a) central loading; b) loading moment applied to the upper cross-beam; c) loading by the force, applied to the upper cross-beam; d) the loading of columns by transverse forces.

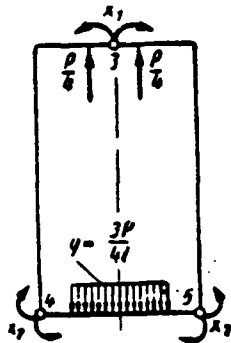

Fig. 155.

Page 176.

Let us determine the coefficients of canonical equations for the rule of Vereshchagin:

$$\delta_{11} = \frac{H}{EJ} \left(\frac{2}{3} + 2\kappa_1 \frac{l}{H} \right);$$

$$\delta_{12} = \delta_{21} = \frac{H}{3EJ};$$

$$\delta_{22} = \frac{H}{EJ} \left(\frac{2}{3} + 2\kappa_2 \frac{l}{H} \right);$$

$$\delta_{1P} = \frac{1}{2EJ} \left(\frac{P \cdot a \cdot H}{3} + \kappa_1 P a^2 \right);$$

$$\delta_{2P} = \frac{1}{2EJ} \left(\frac{P \cdot a \cdot H}{6} - \frac{2}{9} \kappa_2 P l^2 \right).$$

System of the canonical equations:

$$x_1 \delta_{11} + x_2 \delta_{12} = -\delta_{1P};$$

$$x_1 \delta_{21} + x_2 \delta_{22} = -\delta_{2P}.$$

whence

$$x_1 = \frac{\delta_{2P} \delta_{12} - \delta_{1P} \delta_{22}}{\delta_{11} \delta_{22} - \delta_{12}^2}; \quad x_2 = \frac{\delta_{1P} \delta_{12} - \delta_{2P} \delta_{11}}{\delta_{11} \delta_{22} - \delta_{12}^2}.$$

After the substitution of coefficients we will obtain:

$$x_1 = -\frac{p}{2H} \cdot \frac{2\kappa_1 a^3 \left(1 + 3\kappa_2 \frac{l}{H}\right) + \frac{1}{2} aH \left(1 + 4\kappa_2 \frac{l}{H}\right) + \frac{2}{9} \kappa_2 l^3}{1 + 4(\kappa_1 + \kappa_2) \frac{l}{H} + 12\kappa_1 \kappa_2 \frac{l^3}{H^3}}; \quad (67)$$

$$x_2 = \frac{p}{2H} \cdot \frac{\kappa_1 a(a-l) + \frac{4}{9} \kappa_2 l^3 \left(1 + 3\kappa_1 \frac{l}{H}\right)}{1 + 4(\kappa_1 + \kappa_2) \frac{l}{H} + 12\kappa_1 \kappa_2 \frac{l^3}{H^3}} \quad (68)$$

with $\kappa_1 = \kappa_2 = 0$

$$x_1 = -\frac{1}{4} Pa; \quad x_2 = 0.$$

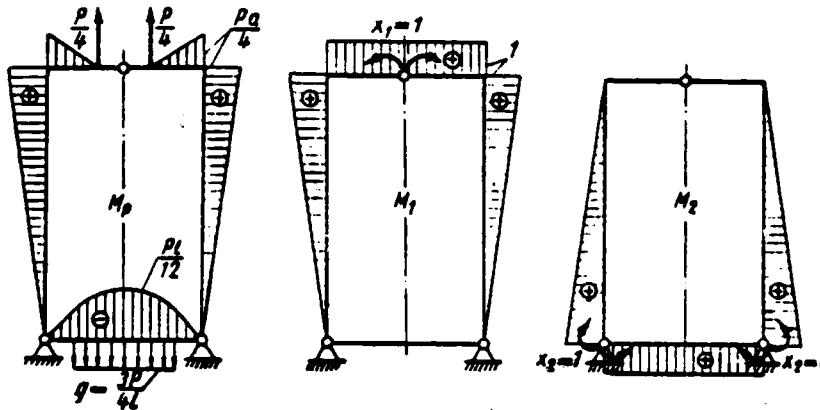

Fig. 156.

Page 177.

The given calculation does not consider spacing effect from the crosshead, i.e., it is suited for the case, when there are sufficiently ample clearances in the guides of cross-beam. So that it would be possible to compare amount of looseness with the saggings/deflections of columns, we determine the displacement of points 1 and 2 (see Fig. 148). Let us exert unit power at these points and let us multiply diagrams/curves from these unit power (Fig. 157) by diagrams/curves \bar{M}_p , M_1 and M_2 (Fig. 156) according to the rule of Vereshchagin.

We will obtain the following expressions:

$$\Delta_1 = -\frac{1}{6EJ} \frac{h_1 h_1'}{H} \left[\left(\frac{Pa}{4} + x_1 \right) (H + h_1) + x_2 (H + h_1') \right]; \quad (69)$$

$$\Delta_2 = -\frac{1}{6EJ} \frac{h_2 h_2'}{H} \left[\left(\frac{Pa}{4} + x_1 \right) (H + h_2) + x_2 (H + h_2') \right]; \quad (70)$$

where Δ_1 - displacement at point 1;

Δ_2 - displacement at point 2.

Central loading - two-cylinder press. Design diagram is given in Fig. 158.

We solve this system just as in the preceding case. Basic system is shown in Fig. 159, and the diagrams/curves of the bending moments from the external load and the unit moments/torques x_1 and x_2 in the basic system - in Fig. 160.

Solution of the unknown power factors:

$$x_1 = -\frac{P}{4H} \times \frac{2\kappa_1(a^2 + a_1^2) \left(1 + 3\kappa_2 \frac{l}{H}\right) + \frac{1}{2} H(a + a_1) \left(1 + 4\kappa_2 \frac{l}{H}\right) + \frac{4}{9} \kappa_2 l^2}{1 + 4(\kappa_1 + \kappa_2) \frac{l}{H} + 12\kappa_1 \kappa_2 \frac{l^2}{H^2}}; \quad (71)$$

$$x_2 = \frac{P}{4H} \cdot \frac{\kappa_1(a^2 + a_1^2) - \kappa_1 l(a + a_1) + \frac{8}{9} \kappa_2 l^2 \left(1 + 3\kappa_1 \frac{l}{H}\right)}{1 + 4(\kappa_1 + \kappa_2) \frac{l}{H} + 12\kappa_1 \kappa_2 \frac{l^2}{H^2}} \quad (72)$$

with $\kappa_1 = \kappa_2 = 0$

$$x_1 = -\frac{1}{8} P(a + a_1); \quad x_2 = 0.$$

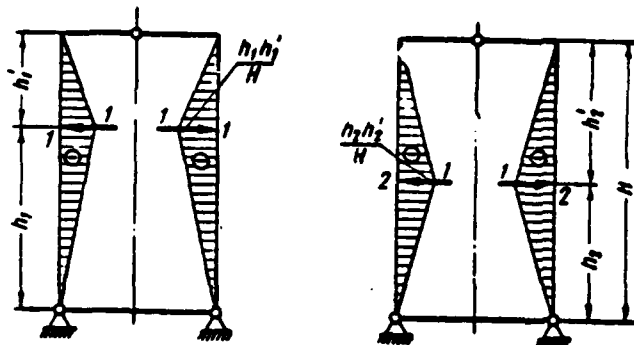

Fig. 157.

Page 178.

The solution for the displacements of points 1 and 2 will be:

$$\Delta_1 = -\frac{1}{6EJ} \cdot \frac{h_1 h_1'}{H} \left[\left(\frac{Pa}{8} + \frac{Pu_1}{8} + x_1 \right) (H + h_1) + x_2 (H + h_1') \right]; \quad (73)$$

$$\Delta_2 = -\frac{1}{6EJ} \cdot \frac{h_2 h_2'}{H} \left[\left(\frac{Pa}{8} + \frac{Pu_1}{8} + x_1 \right) (H + h_2) + x_2 (H + h_2') \right]. \quad (74)$$

The given solutions do not consider the spacing effect of the crosshead, since it was assumed that the clearances in the bushings are so great that the columns can freely converge.

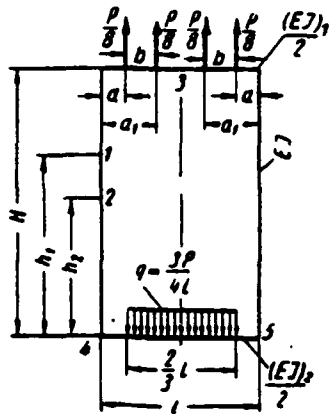

Fig. 158.

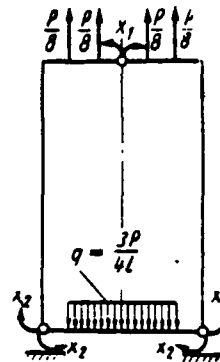

Fig. 159.

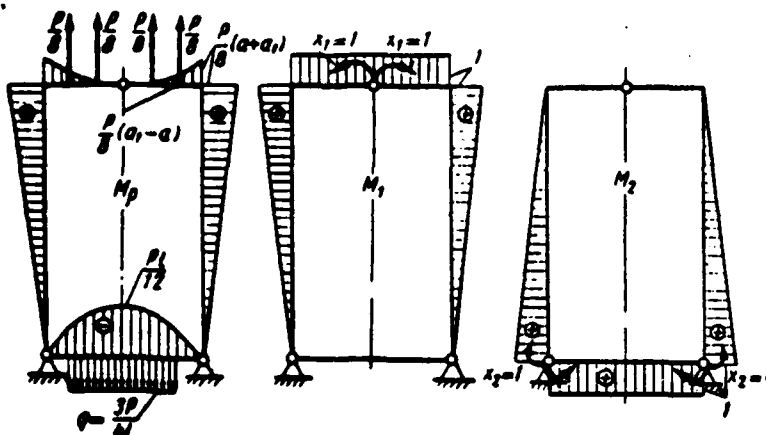

Fig. 160.

Page 179.

Central loading - single-cylinder press. Jam of columns in the crosshead. Upper part of the frame. Let us consider the case when the clearances between columns and guides of the crosshead they are absent or are sufficiently low and them can be disregarded/neglected.

Assuming/setting the crosshead sufficient rigid, the frame with a height/altitude of H can be considered as two independent frames with capped ends with a height/altitude of h_1 and h_2 (Fig. 161).

The given system is twice statically indeterminable. For disclosing/expanding the static indefinability blind joints at points 1, 2, 3.

During the determination of moments/torques x_1 and x_2 , which appear in the hinges, it is possible to use the method of canonical equations.

The system, accepted as the basis, it is shown in Fig. 162, and the diagrams/curves of the bending moments from the external load and moments/torques x_1 and x_2 in the basic system - in Fig. 163.

As a result of the solution we obtain

$$x_1 = -\frac{p}{2h_1} \frac{2\kappa_1 a^2 + \frac{1}{2} a \cdot h_1}{1 + 4\kappa_1 \frac{l}{h_1}}; \quad (75)$$

$$x_2 = \frac{p}{2h_1} \frac{\kappa_1 a (a-l)}{1 + 4\kappa_1 \frac{l}{h_1}}. \quad (76)$$

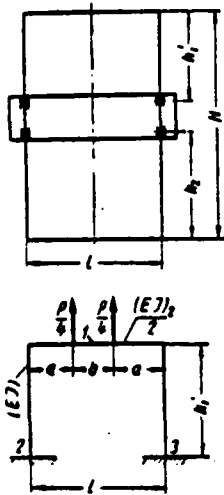

Fig. 161.

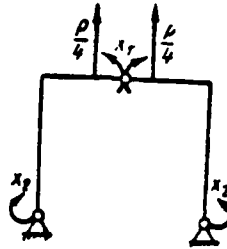

Fig. 162.

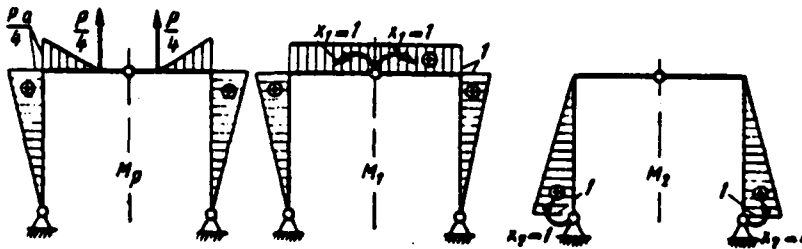

Fig. 163.

Page 180.

With $k_1=0$

$$x_1 = -\frac{1}{4} Pa; \quad x_2 = 0.$$

Central load - two-cylinder press. Jam of columns. Upper part of the frame. Design diagram, basic system and diagrams/curves of the bending moments from the external load and moments/torques x_1 and x_2 in the basic system are shown in Fig. 164-166.

Deciding, as in the preceding case, we will obtain

$$x_1 = -\frac{p}{4h_1} \frac{2\kappa_1(a^2 + a_1^2) + \frac{1}{2}h_1'(a + a_1)}{1 + 4\kappa_1 \frac{l}{h_1}}; \quad (77)$$

$$x_2 = \frac{p}{4h_1} \frac{\kappa_1(a^2 + a_1^2) - \kappa_1 l(a + a_1)}{1 + 4\kappa_1 \frac{l}{h_1}}. \quad (78)$$

With $\kappa_1 = 0$

$$x_1 = -\frac{1}{8} P(a + a_1); \quad x_2 = 0.$$

Central loading - jam of columns. Lower part of the frame. For the lower part of the frame the solutions are analogous both for one-cylinder and for the multicylinder press.

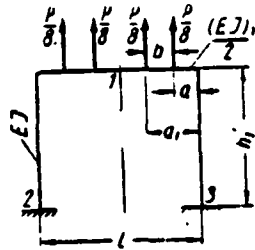

Fig. 164.

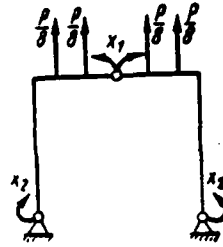

Fig. 165.

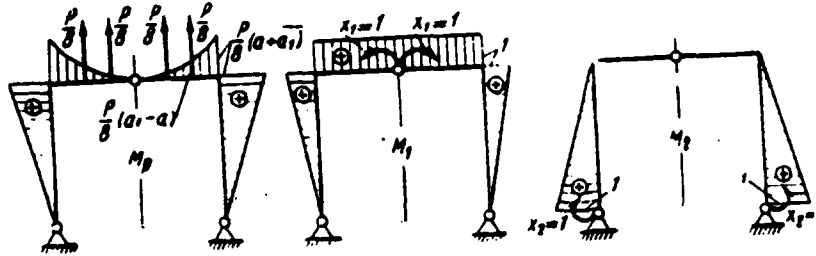

Fig. 166.

Page 181.

The design diagram, taken for the basic system, and the diagrams/curves of the bending moments from the external load and the moments/torques from x_1 and x_2 in the basic system are shown in Fig. 167-169.

Solutions for the unknown power factors:

$$x_1 = -\frac{q}{9h_2} \cdot \frac{l^3 h_2 + 2\kappa_2 l^3}{1 + 4\kappa_2 \frac{l}{h_2}}; \quad (79)$$

$$x_2 = -\frac{q\kappa_2 l^3}{9h_2 \left(1 + 4\kappa_2 \frac{l}{h_2}\right)}. \quad (80)$$

where

$$q = \frac{3}{4} \cdot \frac{P}{L}$$

Loading of the frame of press by the moment/torque, applied to the upper cross-beam. Design diagram is given in Fig. 170.

This system one time is statically indeterminable.

Let us cut upper cross-beam on the middle of flight/span. In this section/cut only conversely symmetrical factors, namely shearing force x , can arise.

Basic system is given in Fig. 171.

The diagrams/curves of the bending moments from the external load and the shearing force in the basic system take the form, shown in Fig. 172 and 173.

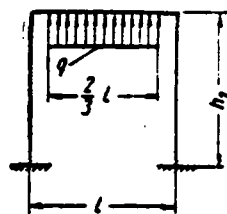

Fig. 167.

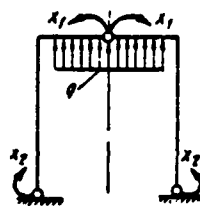

Fig. 168.

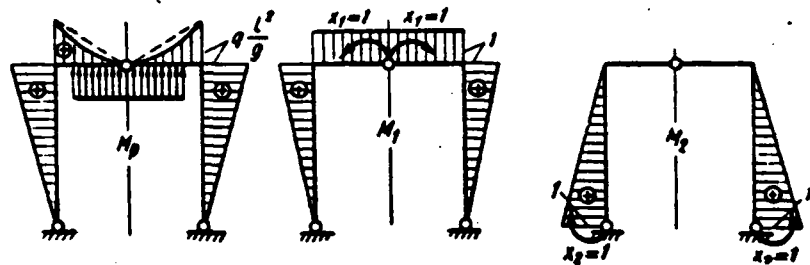

Fig. 169.

Page 182.

Canonical equation takes the form

$$\delta_{33}x_3 = -\delta_{3P},$$

whence

$$x_3 = -\frac{\delta_{3P}}{\delta_{33}}.$$

Expressions for the displacements

$$\delta_{33} = \frac{Hl^3}{8EJ} \left(3 + \kappa_1 \frac{l}{H} + \kappa_2 \frac{l}{H} \right);$$

$$\delta_{3P} = -\frac{Ml^3}{8EJ} \left(2 \frac{H}{l} + \kappa_1 + \kappa_2 \right).$$

Value of the unknown power factor

$$x_3 = \frac{3}{4l} M \frac{2 + \kappa_1 \frac{l}{H} + \kappa_2 \frac{l}{H}}{3 + \kappa_1 \frac{l}{H} + \kappa_2 \frac{l}{H}}. \quad (81)$$

We further determine displacements at points 1 and 2.

We construct diagram/curve from the unit power in the basic system, applied at points 1 and 2 (Fig. 174 and 175).

Displacements at points 1 and 2 will have expressions

$$\Delta_1 = \frac{h_1}{8EJ} \left(Mh_1 + \kappa_2 Ml - 2x_2/h_1 - \frac{4}{3} \kappa_2 x_2^2 \right); \quad (82)$$

$$\Delta_2 = \frac{h_2}{8EJ} \left(Mh_2 + \kappa_2 Ml - 2x_2/h_2 - \frac{4}{3} \kappa_2 x_2^2 \right). \quad (83)$$

We determine the displacement of upper cross-beam, after plotting moment diagram from the unit power, applied to the upper cross-beam (Fig. 176), analogously.

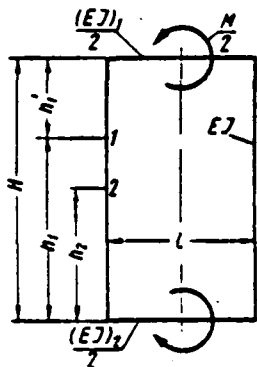

Fig. 170.

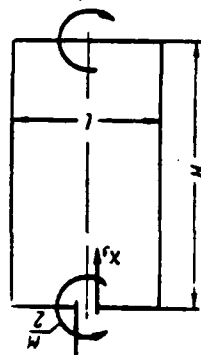

Fig. 171.

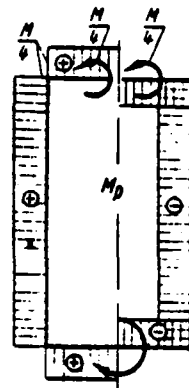

Fig. 172.

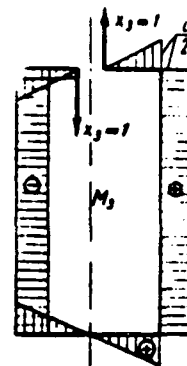

Fig. 173.

Page 183.

After producing the necessary calculations, we find

$$\Delta^0 = \frac{H}{8EJ} \left(HM + \kappa_2 l M - 2Hlx_2 - \frac{4}{3} \kappa_2 l^2 x_2 \right). \quad (84)$$

Loading of the frame of press by the force, applied to the upper cross-beam. Calculated and basic systems are given in Fig. 177 and 178.

We construct the diagrams/curves of the bending moments from the external load and the shearing force in the basic system (Fig. 179 and 180).

After producing the necessary calculations, we find:

the value of the unknown power factor

$$x_2 = \frac{3}{4} N \frac{H}{l} \frac{1 + \kappa_2 \frac{l}{H}}{3 + \kappa_2 \frac{l}{H} + \kappa_2 \frac{l}{H}}; \quad (85)$$

the displacement of points 1 and 2

$$\Delta_1 = \frac{h_1}{8EJ} \left(\frac{2}{3} Hh_1N + \frac{1}{3} h_1h_1'N + \kappa_2Hh_1N - 2x_2/h_1 - \frac{4}{3} \kappa_2x_2^2 \right); \quad (86)$$

$$\Delta_2 = \frac{h_2}{8EJ} \left(\frac{2}{3} Hh_2N + \frac{1}{3} h_2h_2'N + \kappa_2NHl - 2x_2/h_2 - \frac{4}{3} \kappa_2x_2^2 \right). \quad (87)$$

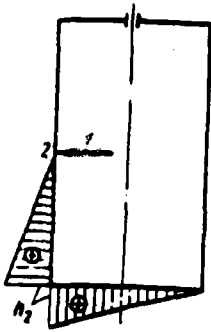

Fig. 174.

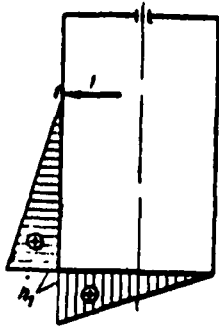

Fig. 175.

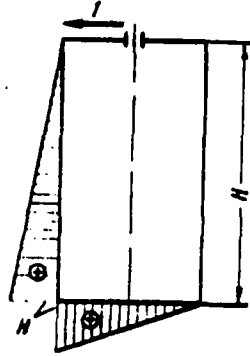

Fig. 176.

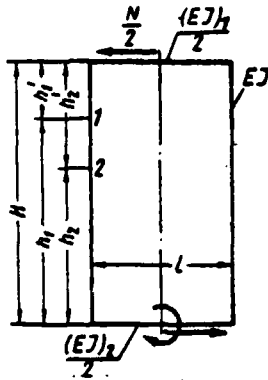

Fig. 177.

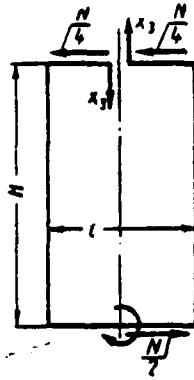

Fig. 178.

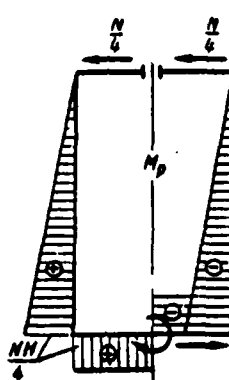

Fig. 179.

Page 184.

Horizontal displacement of the upper cross-beam

$$\Delta^a = \frac{1}{EJ} \left(\frac{NH^3}{12} + \frac{\kappa_2}{8} H^2 l N - \frac{1}{4} H^2 l x_2 - \frac{1}{6} \kappa_2 H l^2 x_2 \right). \quad (88)$$

Loading of the frame of press by the force couples applied to the columns. Calculated and basic systems are given in Fig. 181 and 182.

We construct the diagrams/curves of the bending moments from the external load and the shearing force in the basic system (Fig. 183 and 184).

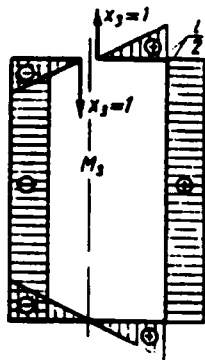

Fig. 180.

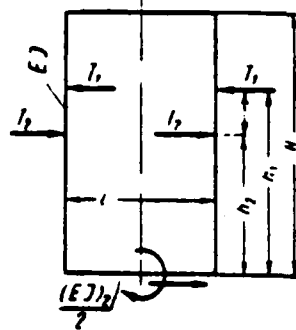

Fig. 181.

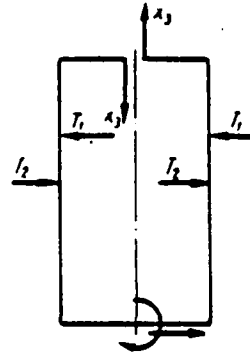

Fig. 182.

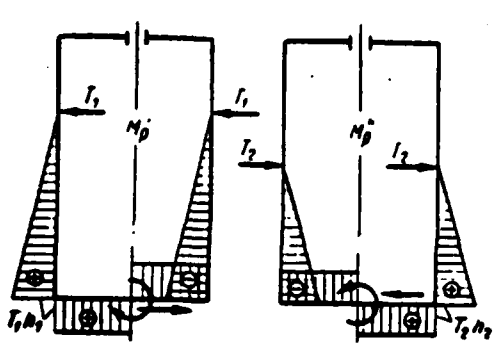

Fig. 183.

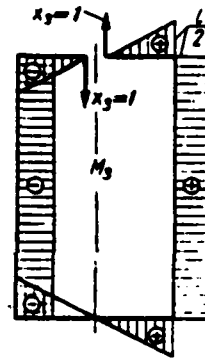

Fig. 184.

Page 185.

After producing the necessary calculations, we will obtain:

expression for the unknown power factor

$$x_3 = \frac{3}{HI} \cdot \frac{T_1 h_1^2 \left(1 + \kappa_1 \frac{l}{h_1}\right) - T_2 h_2^2 \left(1 + \kappa_2 \frac{l}{h_2}\right)}{3 + \kappa_1 \frac{l}{H} + \kappa_2 \frac{l}{H}}; \quad (89)$$

the displacement of points 1 and 2

$$\Delta_1 = \frac{1}{EJ} \left(\frac{T_1 h_1^3}{3} + \frac{T_2 h_2^3}{6} - \frac{T_2 h_2^2 h_1}{2} + \frac{1}{2} \kappa_2 T_1 h_1^2 l - \frac{1}{2} \kappa_2 T_2 h_1 h_2 l - x_2 \frac{h_1^2 l}{4} - \kappa_2 x_2 \frac{l^2 h_1}{6} \right); \quad (90)$$

$$\Delta_2 = \frac{1}{EJ} \left(\frac{1}{2} T_1 h_1 h_2^2 - \frac{1}{6} T_1 h_2^3 - \frac{1}{3} T_2 h_2^3 + \frac{1}{2} \kappa_2 T_1 h_1 h_2 l - \frac{1}{2} \kappa_2 T_2 h_2^2 l - \frac{1}{4} x_2 h_2^2 l - \frac{1}{6} \kappa_2 x_2 h_2 l^2 \right); \quad (91)$$

the horizontal displacement of the upper cross-beam

$$\Delta^a = \frac{1}{EJ} \left(\frac{1}{3} T_1 H h_1^2 + \frac{1}{6} T_1 h_1^2 h_1' + \frac{1}{2} \kappa_2 T_1 h_1 H l - \frac{1}{3} T_2 h_2^2 H - \frac{1}{6} T_2 h_2^2 h_2' - \frac{1}{2} \kappa_2 T_2 h_2 H l - x_2 \frac{H^2 l}{4} - \kappa_2 x_2 \frac{H l^2}{6} \right). \quad (92)$$

Loading of the frame of press by the force couple applied to one column. Design diagram is given in Fig. 185.

Let us divide all acting forces on two groups of the loads: symmetrical relative to the vertical axis/axle (Fig. 186) and vice versa symmetrical (Fig. 187).

Solution of balanced system. Let us cut upper cross-beam on the middle of flight/span. In this section/cut can arise only symmetrical power factors, namely: the normal force x_1 and the bending moment x_2 . Basic system is given in Fig. 188. We further construct the diagrams/curves of the bending moments from the external load, the longitudinal force x_1 and the bending moment x_2 in the basic system (Fig. 189-190).

The solutions of canonical equations for the case in question take the form

$$x_1 = \frac{\delta_{12}\delta_{11} - \delta_{12}\delta_{22}}{\delta_{11}\delta_{22} - \delta_{12}^2}; \quad x_2 = \frac{\delta_{12}\delta_{11} - \delta_{12}\delta_{22}}{\delta_{11}\delta_{22} - \delta_{12}^2}.$$

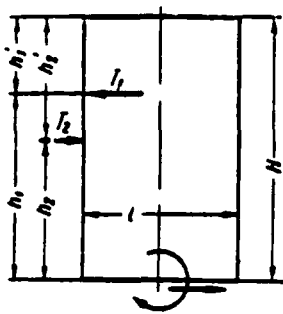

Fig. 185.

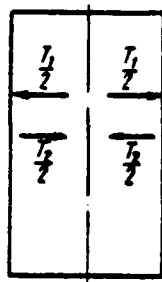

Fig. 186.

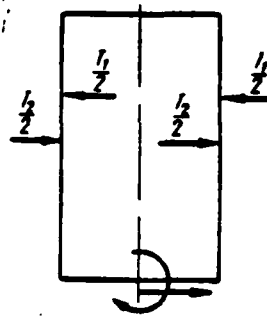

Fig. 187.

Page 186.

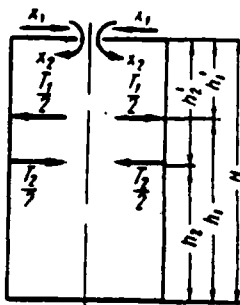

Fig. 188.

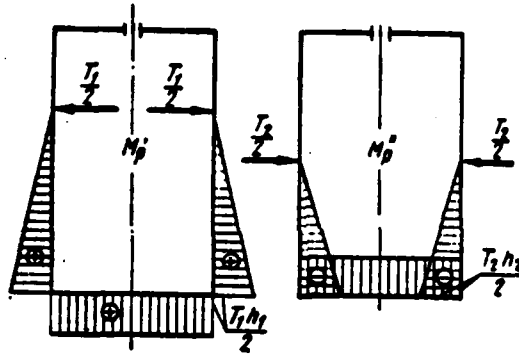

Fig. 189.

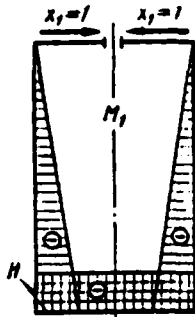

Fig. 190.

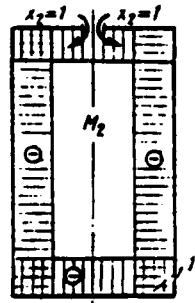

Fig. 191.

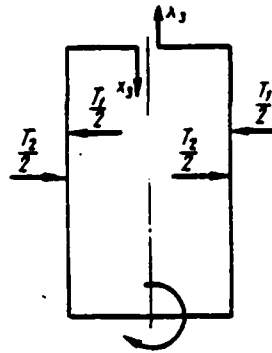

Fig. 192.

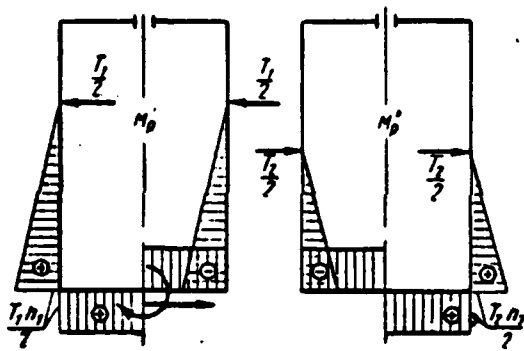

Fig. 193.

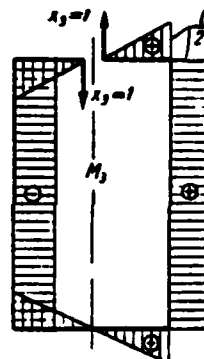

Fig. 194.

Page 187.

After substitution we will obtain

$$x_1 = \frac{3}{H^3} \times \frac{\left(\frac{1}{2} + \kappa_1 \frac{l}{H}\right)(T_1 h_1^2 - T_2 h_2^2 + 2\kappa_2 T_1 h_1 l - 2\kappa_2 T_2 h_2 l) + \frac{1}{3H}(T_2 h_2^3 - T_1 h_1^3)\left(1 + \kappa_1 \frac{l}{H} + \kappa_2 \frac{l}{H}\right)}{1 + 4(\kappa_1 + \kappa_2) \frac{l}{H} + 12\kappa_1 \kappa_2 \frac{l^2}{H^2}}; \quad (93)$$

$$x_2 = \frac{1}{H} \times \frac{T_2 h_2^2 \left(\frac{1}{2} + \kappa_2 \frac{l}{H}\right) - T_1 h_1^2 \left(\frac{1}{2} + \kappa_2 \frac{l}{H}\right) + \frac{1}{H} \left(\frac{1}{2} + \kappa_2 \frac{l}{H}\right) (T_1 h_1^3 - T_2 h_2^3)}{1 + 4(\kappa_1 + \kappa_2) \frac{l}{H} + 12\kappa_1 \kappa_2 \frac{l^2}{H^2}}. \quad (94)$$

Solution of conversely balanced system. Let us cut upper cross-beam on the middle. In this section/cut only conversely symmetrical power factors, namely transverse force x_3 can arise.

Basic system for this case is given on Fig. 192.

We construct the diagrams/curves of the bending moments from the external load and transverse force x_3 (Fig. 193 and 194).

After producing the necessary calculations, we find:

expression for the unknown power factor

$$x_3 = \frac{3}{2Hl} \cdot \frac{T_1 h_1^2 \left(1 + \kappa_2 \frac{l}{h_1}\right) - T_2 h_2^2 \left(1 + \kappa_3 \frac{l}{h_2}\right)}{3 + \kappa_2 \frac{l}{H} + \kappa_3 \frac{l}{H}}; \quad (95)$$

the displacement of points 1 and 2

$$\begin{aligned} \Delta_1 = \frac{1}{EJ} & \left(\frac{1}{3} T_1 h_1^3 + \frac{1}{6} T_2 h_2^3 - \frac{1}{2} T_2 h_2^2 h_1 + \frac{3}{4} \kappa_2 T_1 h_1^2 l - \right. \\ & - \frac{3}{4} \kappa_2 T_2 h_1 h_2 l - \frac{x_1 H h_1^2}{3} - \frac{x_1}{6} h_1^2 h_1^2 - \kappa_2 x_1 H h_1 l - \frac{x_2}{2} h_1^2 - \kappa_2 x_2 h_1 l - \\ & \left. - x_3 \frac{h_1^2 l}{4} - \kappa_2 x_3 \frac{H h_1}{6} \right); \quad (96) \end{aligned}$$

$$\begin{aligned} \Delta_2 = \frac{1}{EJ} & \left(\frac{1}{2} T_1 h_1 h_2^2 - \frac{1}{6} T_1 h_2^3 - \frac{1}{3} T_2 h_2^3 + \frac{3}{4} \kappa_2 T_1 h_1 h_2 l - \right. \\ & - \frac{3}{4} \kappa_2 T_2 h_2^2 l - \frac{x_1}{3} H h_2^2 - \frac{x_1}{6} h_2^2 h_2^2 - \kappa_2 x_1 H h_2 l - \frac{x_2}{2} h_2^2 - \\ & \left. - \kappa_2 x_2 h_2 l - \frac{1}{4} x_3 h_2^2 l - \frac{1}{6} \kappa_2 x_3 h_2^2 H \right); \quad (97) \end{aligned}$$

the horizontal displacement of the upper cross-beam

$$\begin{aligned} \Delta^e = \frac{1}{EJ} & \left(\frac{1}{6} T_1 H h_1^2 + \frac{1}{12} T_1 h_1^2 h_1^2 + \frac{1}{4} \kappa_2 T_1 h_1 H l - \right. \\ & - \frac{1}{6} T_2 h_2^2 H - \frac{1}{12} T_2 h_2^2 h_2^2 - \frac{1}{4} \kappa_2 T_2 h_2 H l - x_3 \frac{H^2 l}{4} - \kappa_2 x_3 \frac{H^2}{6} \left. \right). \quad (98) \end{aligned}$$

Loading of the frame of press by the bulging out forces, applied to the columns. Design diagram for this case is given in Fig. 195.

Let us divide all forces which function on the frame, on two groups of the loads: symmetrical relative to the vertical axis/axle (Fig. 196) and vice versa symmetrical (Fig. 197).

Solution of balanced system. The system accepted as the basic is shown in Fig. 198.

The diagrams/curves of the bending moments from the external load and the unknown power factors - the normal force x_1 and the bending moment x_2 , are given in Fig. 199 and 200.

Solution of the system of the canonical equations, written for the present instance

$$x_1 = \frac{3}{H^2} \cdot \frac{A}{1 + 4(\kappa_1 + \kappa_2) \frac{l}{H} + 12\kappa_1\kappa_2 \frac{l^2}{H^2}}, \quad (99)$$

$$x_2 = \frac{3}{H} \cdot \frac{B}{1 + 4(\kappa_1 + \kappa_2) \frac{l}{H} + 12\kappa_1\kappa_2 \frac{l^2}{H^2}}, \quad (100)$$

where

$$\begin{aligned} A &= T_1 h_1^2 \left(\frac{1}{2} + 2\kappa_1 \frac{l}{H} \right) \left(\frac{1}{2} + \kappa_2 \frac{l}{h_1} \right) - T_2 h_2^2 \left(\frac{1}{2} + \kappa_2 \frac{l}{h_2} \right) \times \\ &\times \left(3 + 2\kappa_1 \frac{l}{H} + 4\kappa_2 \frac{l}{H} \right) + \frac{1}{3H} (T_2 h_2^3 - T_1 h_1^3) \left(1 + \kappa_1 \frac{l}{H} + \kappa_2 \frac{l}{H} \right); \\ B &= \frac{1}{6H} \left(1 + 2\kappa_2 \frac{l}{H} \right) (T_1 h_1^3 - T_2 h_2^3) - \frac{1}{6} T_1 h_1^2 \left(1 + 2\kappa_2 \frac{l}{h_1} \right) + \\ &+ T_2 h_2^2 \left(1 + 2\kappa_2 \frac{l}{h_2} \right) \left(\frac{5}{6} + 2\kappa_2 \frac{l}{H} \right). \end{aligned}$$

Solution of conversely balanced system. Basic system is given in Fig. 201.

We construct the diagrams/curves of the bending moments from the external load (Fig. 202) and transverse force x , of Fig. (203) in the basic system.

Page 189.

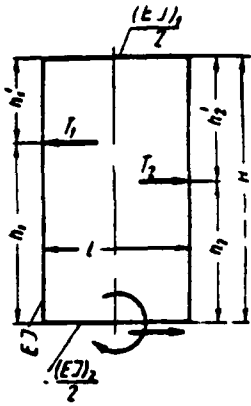

Fig. 195.

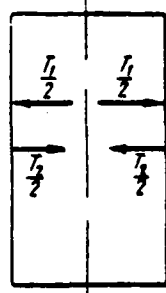

Fig. 196.

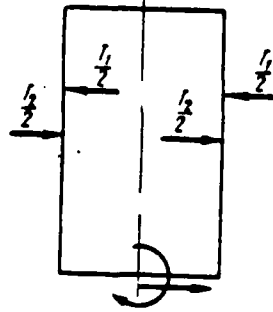

Fig. 197.

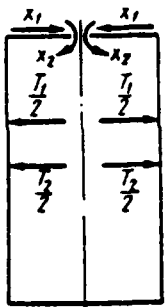

Fig. 198.

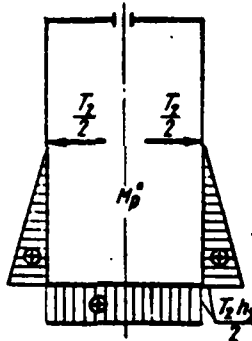
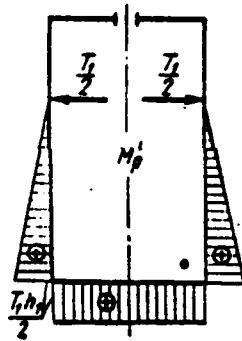

Fig. 199.

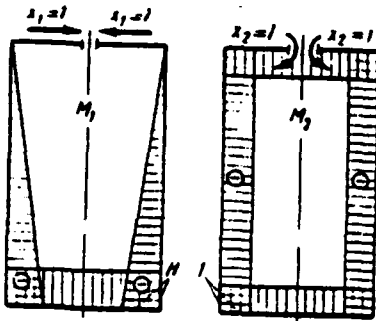

Fig. 200.

Page 190.

After producing the necessary calculations, we will obtain:

expression for the unknown power factor

$$x_3 = \frac{3}{2Hl} \cdot \frac{T_1 h_1^2 \left(1 + \kappa_2 \frac{l}{h_1}\right) - T_2 h_2^2 \left(1 + \kappa_2 \frac{l}{h_2}\right)}{3 + \kappa_1 \frac{l}{H} + \kappa_2 \frac{l}{H}}; \quad (101)$$

the displacement of points 1 and 2

$$\Delta_1 = \frac{1}{EJ} \left(\frac{1}{3} T_1 h_1^3 + \frac{3}{4} T_1 h_1^2 l + \frac{1}{4} \kappa_2 T_2 h_1 h_2 l - \frac{x_1 H h_1^2}{3} - \frac{x_1 h_1^2 h_1}{6} - \kappa_2 x_1 H h_1 l - x_2 \frac{h_1^2}{2} - \kappa_2 x_2 h_1 l - x_3 \frac{h_1^2 l}{4} - \kappa_2 x_3 \frac{h_1^2}{6} \right); \quad (102)$$

$$\Delta_2 = \frac{1}{EJ} \left(\frac{1}{2} T_1 h_1 h_2^2 - \frac{1}{6} T_1 h_2^3 + \frac{3}{4} \kappa_2 T_1 h_1 h_2 l + \frac{\kappa_2}{4} T_2 h_2^2 l - \frac{x_1 H h_2^2}{3} - \frac{x_1 h_2^2 h_2}{6} - \kappa_2 x_1 H h_2 l - x_2 \frac{h_2^2}{2} - \kappa_2 x_2 h_2 l - \frac{1}{4} x_3 h_2^2 l - \frac{1}{6} \kappa_2 x_3 h_2^2 \right); \quad (103)$$

the horizontal displacement of the upper cross-beam

$$\Delta^0 = \frac{1}{EJ} \left(\frac{1}{6} T_1 H h_1^2 + \frac{1}{12} T_1 h_1^2 h_1 + \frac{1}{4} \kappa_2 T_1 h_1 H l - \frac{1}{6} T_2 h_2^2 H - \frac{1}{12} T_2 h_2^2 h_2 - \frac{1}{4} \kappa_2 T_2 h_2 H l - x_3 \frac{H^2 l}{4} - \kappa_2 x_3 \frac{H^2}{6} \right). \quad (104)$$

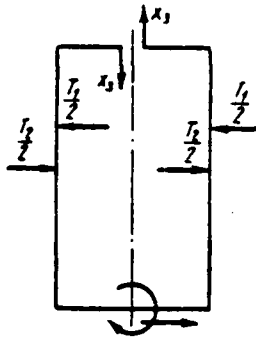

Fig. 201.

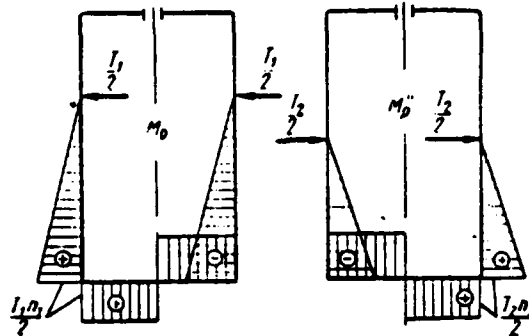

Fig. 202.

Page 191.

Order of calculation of the frame of press. Using the obtained expressions for the definition: the forces, which function on the frame (equations of static equilibrium and expressions for the forces and the moments/torques, which function in the supports of plungers), unknown internal power factors from the elementary loads, which function on the frame, and the displacements of upper cross-beam and columns at the points of application of force from the crosshead, it is possible to take the following order of calculation of the frame of press.

1. The design diagram of mounting is established/installed and are determined all its calculated sizes/dimensions and

characteristics of the separate elements/cells: EJ ; $(EJ)_1$; $(EJ)_2$; κ_1 ; κ_2 . The moments of the inertia of the cross bars of frame (upper and lower cross-beam) are determined, using the method given above.

In the majority of the cases for the forging and stamping presses by effort/force to 10000 t of the hardness of cross-beams they can be taken as the equal to infinity, i.e., $\kappa_1 = \kappa_2 = 0$.

2. The statically determinable loads, which function on the frame, are computed.

3. It is assumed that the clearances in the bushings of the crosshead exceed the saggings/deflections of columns in the sections/cuts under the forces, which function on the columns from the side of cross-beam.

The calculation of frame to the central loading, by which are determined, is produced: the normal forces, which function on the columns, moments/torques and shearing forces in the calculated cross-sections, the displacement of columns at points 1 and 2 (under the transverse forces).

4. If the saggings/deflections of columns at points 1 and 2 prove to be considerably ample clearances in the guides of the

crosshead, then solution for the central load with the jam of columns in the crosshead is applied.

In such a case, when saggings/deflections insignificantly exceed clearances in the guides of cross-beam, problem is solved into two stages: solution for the case of central loading with the free displacement of columns at points 1 and 2 to the selection of clearances first is given and then is given solution for the second case, i.e., with the jam of columns in the crosshead.

5. The calculation of frame from the action of the elementary loads, which appear with the eccentric loading of press, is produced. In this case internal power factors and displacements of columns and upper cross-beam in the force function which function on the mounting, are determined.

6. The extents of movements (columns and upper cross-beam), found at the solution of frame are totaled, which is loaded by elementary forces and moments/torques.

7. Compiles an equation of the static equilibrium of the crosshead.

8. They are comprised from the geometric considerations of the

equations, which are determining the relation of the displacements of columns at the points of application of force which function from the side of the crosshead, and the relation of displacements over one of the sections/cuts of column and upper cross-beam of frame.

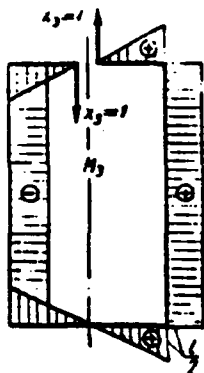

Fig. 203.

Page 192.

9. System of equations (paragraphs 7 and 8) is solved and the statically indeterminable external loads on the frame are located.

10. On the obtained loads (p. 9) the values of the internal power factors, which function in the section/cut of upper cross-beam on the middle of flight/span, are determined and are totaled.

11. Total diagrams/curves for the bending moments, the normal and shearing forces, which function on the frame, are plotted. The maximum values of power factors, obtained from these diagrams/curves, are used for calculating the parts of mounting.

Columns.

The columns, which link upper and lower cross-beams in the rigid frame and being guides for the crosshead, are loaded by longitudinal and transverse forces and moments/torques, which appear during the deformation of cross-beams, and also with the eccentric loading of press.

Construction/design and material of columns must provide their sufficient strength and service life.

The hardness of the frame of press to a considerable degree depends on construction/design and form of the connection of the columns with the cross-beams.

For guaranteeing the frame of press necessary for hardness during its installation the tightening of columns in the cross-beams is produced by the effort/force, which exceeds the effort/force, received by column from the nominal effort/force, developed with press.

Therefore the calculation of columns must be produced over two sections/cuts: over section/cut a - a (Fig. 204), i.e., in the section of column, which envelopes in the cross-beam; over

section/cut b - b, i.e., under the lower internal nut of column.

From the calculation of the frame of press the value of moment/torque M , which functions on the column in the place of its framing in the cross-beam, is known.

The tightening of column must ensure the absence of the shift/shear of nut on the cross-beam with the maximum effort/force, developed with press with the eccentricity of loading maximum permissible for the press.

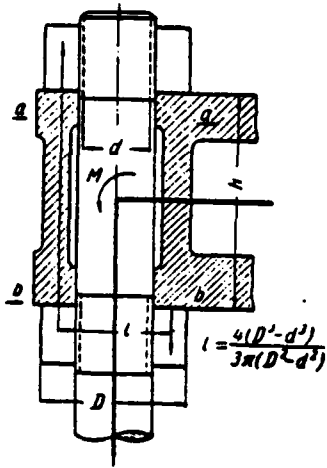

Fig. 204.

Page 193.

The equation of the equilibrium of column, if we assume sealed it in the section/cut under the upper nut, will take the form

$$M = \Delta P \mu H + \Delta P l, \quad (105)$$

where ΔP - excessive effort/force, which functions on the column and caused by the pretightening of nuts;

H - height/altitude of upper cross-beam;

μ - coefficient of friction.

From this equation

$$\Delta P = \frac{M}{\mu H + l}. \quad (106)$$

During the work of press occurs the pressing of the thread of columns and nut seats and cross-beam, which must be considered during the calculation of the effort/force of the pretightening.

Let us designate the value of pressing through δ in mm; then the further effort/force, which considers the possible pressing of bearing surfaces, will be equally

$$\Delta P' = \frac{\delta E f_{a-a}}{H}, \quad (107)$$

where f_{a-a} — net area of column. After coming to light/detecting/exposing calculated effort/force for section/cut a - a, let us write expression for determining the diameter of the column:

$$d_{a-a} > \sqrt{\frac{4}{\pi} \cdot \frac{P + \frac{M}{\mu H + l}}{\sigma_0 - \frac{\delta E}{H}}}. \quad (108)$$

The value of pressing δ tentatively can be taken as the equal to 0.2-0.4 mm (high values for the large diameters of columns), and the coefficient of friction $\mu=0.15-0.2$. Allowable stress during the calculation of column on static load is taken as the equal to

$$\sigma_0 = \frac{\sigma_s}{n},$$

where σ_s — yield point for the material of column;

n — safety factor in yield point;

$n=2.0-2.2.$

For manufacturing the columns the carbon steel (with content of 1.5-2.0% of nickel and 0.3-0.35% of carbon) is been commonly used. The allowable stress/voltage for such steels is accepted at $\sigma_0 \approx 1500$ kg/cm². The safety factor, equal to 2.0-2.2, is accepted taking into account the stress concentration factor in the thread of column, equal to 1.8-2.0.

Section/cut b-b of the columns (see Fig. 204) under the lower nut must be relied on fatigue, since in this section/cut functions pulsating load from 0 to P_{max} .

Stress/voltage in section/cut b - b

$$\sigma_{b-b} = \kappa \left(\frac{4P}{\pi d_{b-b}^2} + \frac{32M}{\pi d_{b-b}^3} \right) \quad (109)$$

where κ - stress concentration factor in the thread. With the execution of the columns of powerful/thick presses by the hollow ones (with the central drilling, usually made by the diameter of $d_1=150-250$ mm) of expression (108) and (109) they will take the form

$$d_{a-a} > \sqrt{\frac{4}{\pi} \cdot \frac{P + \frac{M}{\mu H + l}}{\sigma_q - \frac{8E}{H}} - d_1^2} \quad (110)$$

$$\sigma_{b-b} = \kappa \left[\frac{4P}{\pi (d_{b-b}^2 - d_1^2)} + \frac{M \cdot 32d_{b-b}}{\pi (d_{b-b}^4 - d_1^4)} \right] \quad (111)$$

Page 194.

During the construction of the column of one diameter over the entire length its diameter must be accepted in terms of the large value of d_{a-d} and d_{b-g} .

During the design of press, at the stage, when all sizes/dimensions of its parts are not yet established/installed and it is not possible to produce the refined calculation of the power factors, which function in the frame of press, the sizes/dimensions of columns can be preliminary designed on the nominal effort/force of press, which functions centrally (eccentricity it is absent) without taking into account the hardness of crossheads (EJ traverse \Rightarrow).

Allowable stresses in the columns with this simplified method are accepted 400-800 kg/cm².

Columns usually are made with the persistent buttress thread. Pitch of thread can be determined according to the relationship/ratio

$$t \approx 5 + 0,0135d,$$

(112)

where t - pitch of thread in mm;

d - outside diameter of column in mm (from 150 mm and above).

For smaller values of d pitch of thread t take ≈ 5 mm.

The calculation of the threading of the column is produced to the specific pressure, the approximately equal to 600 kg/cm^2 , to the shear/section, taking allowable stress as the approximately equal to 250 kg/cm^2 , and on the bend of turns (in the expanded/scanned state), taking allowable stress as the approximately equal to 500 kg/cm^2 .

The sizes/dimensions of the nuts of columns can be accepted on the following relationships/ratios:

height/altitude $h = (1-1.2)d$;

the outside diameter $D = 1.5d$.

The selected size/dimension of nut D must be checked to the specific base pressure, which must not exceed approximately 800

kg/cm².

Basic Cross-beams and Bolsters.

The basic cross-beams and the working plates/slabs of hydraulic presses (upper, lower and crossheads, table and ^{others}), which have large overall dimensions and calculated flights/spans, are loaded by the concentrated forces, which call high local specific pressures on the working surfaces.

Page 195.

In this case the character of the application of appearing force can be most indefinite. Therefore the basic parts of presses are manufactured only by steel cast or welded from the rolled stock. The sections/cuts of cross-beams are made by box-shaped ones or girder ones. In the zones of possible loads the base plates of crossheads (upper and lower) must be connected with the dense grid of edges/fins so that it would not appear the large local stresses and sagging.

During the construction of the cross-beam, in which working cylinders are installed, special attention should be given obtaining uniform local hardness in the area of the support of cylinders, since the nonuniformity of the deformation of the surface of cross-beam, on

which the cylinders are based, sharply affects an increase in the local stresses in the walls of cylinder, conjugated/combined with the flange. Best solution is connection/communication of plates/slabs cylindrical bushings with those diverging from them, as far as possible by symmetrically arranged/located, by the edges/fins of small sections/cuts (Fig. 205).

The same bushing-edges/fins must be provided for also in the constructions/designs of the crossheads, which receive concentrated loads from the plungers (Fig. 206 and 207).

The dense grids of edges/fins must be provided for also in the center of lower cross-beam and bolster (Fig. 208 and 209), i.e., in the area of maximum specific pressures on the surface of parts and maximum stresses/voltages from the bend.

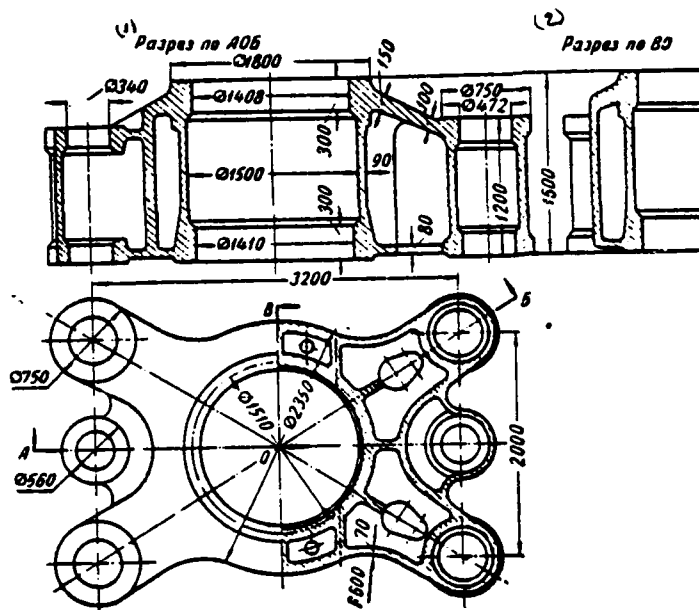

Fig. 205. Upper cross-beam of forging press by effort/force 3000 t.

Key: (1). Section/cut on the AOB. (2). Section/cut on BO.

Page 196.

The parts of powerful/thick presses frequently prove to be such dimensions and weights that it is necessary to perform by their composite/compound, connected tightening bolts. In this case it is necessary to avoid the support of the nuts of bolts to the free, not having local hardness walls.

The vertical edges/fins of castings of composite/compound

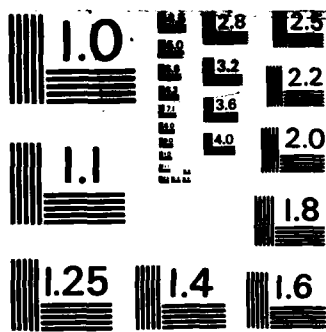

MICROCOPY RESOLUTION TEST CHART
NATIONAL BUREAU OF STANDARDS-1963-A

cross-beams must be combined by bushings. Against the cutting forces acting in the section/cut it is necessary to provide for keys or locks (Fig. 210).

The tightening bolts before the tightening must be preheated in order to guarantee the reliability of the compound of the parts of the cross-beam. For the steel forged tightening bolts made of the carbon steel accept the stresses/voltages, after the tightening equal to 700-800 kg/cm².

Electroslag welding, mastered by the Heavy Machine Building Plants, points out great possibilities for construction and manufacturing the heavy parts of presses. Fabricated members with the same strength, that also cast, can be carried out by lighter, the cycle of their manufacture are shorter. For plant in this case it is not required to manufacture and to preserve the expensive models. Example to the constructions/designs of the welded upper cross-beam of stamping machine by the effort/force 3000 t, worked out by Uralmashzavod [УРАЛМАШЗАВОД - Ural Heavy Machinery Plant im. Sergo Ordzhonikidze], is shown in Fig. 211.

The cross-beams of press - upper, moving, and lower - calculate as beams/gullies on two supports, in this case the allowable stresses receive by sufficiently low ones.

The safety factor, on ultimate strength for steel casting, take as the equal to 6-8 and the respectively allowable stresses 450-600 kg/cm².

For the powerful/thick stamping machines, which develop efforts/forces 15000 t it is above, castings during their calculation with the low voltages frequently according to the weight and the dimension prove to be beyond the limits of the technological possibilities of plants, and in this case allowable stresses are received as somewhat large - to 700-750 kg/cm².

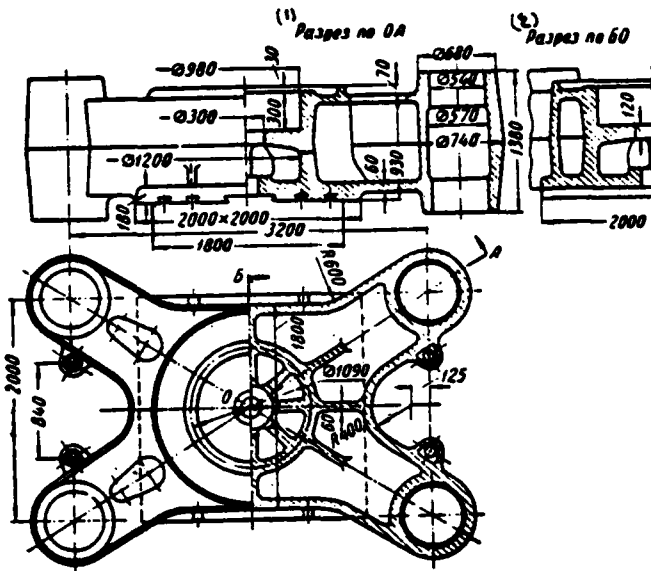

Fig. 206. The crosshead of forging press by effort/force 3000 t.

Key: (1). Section/cut on OA. (2). Section/cut on BO.

Page 197.

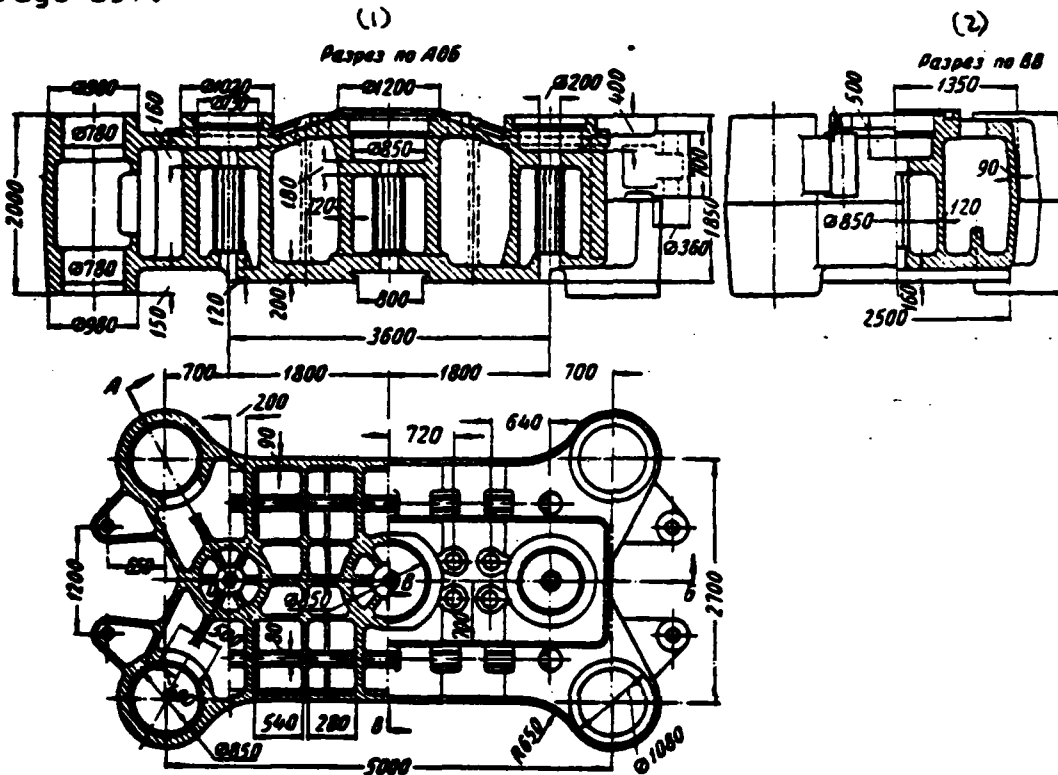

Fig. 207. The crosshead of forging press by effort/force 7000 t.

Key: (1). Section/cut on AOB. (2). Section/cut on VV.

Page 198.

The calculation of upper and lower cross-beams is performed also to the hardness; in this case approximately equal to 0.15 mm accept relative sagging/deflection (sagging/deflection, in reference to the distance between centers of columns) on 1 lin. m.

During the construction of cross-beams, especially lower, frequently its sections/cuts it is necessary to make by variables (Fig. 212).

With an abrupt change in the section/cut along the length of cross-beam it is necessary to test stresses/voltages not only in the section/cut, where functions maximum moment/torque, but also in the sections/cuts, sloped relative to the direction of the action of external forces.

Page 199.

For section/cut a-a (Fig. 212) stress/voltage they will be equal to

$$\sigma = \frac{M}{W_{a-a}} + \frac{P_{a-a}}{F_{a-a}} = \frac{P}{2} \times \frac{l}{W_{a-a}} + \frac{P \cos \alpha}{2 F_{a-a}}, \quad (113)$$

where W_{a-a} - moment of resistance to bending;

F_{a-a} - cross-sectional area.

During the calculation of upper cross-beam the efforts/forces from the cylinders can be applied in the centers of gravity of the half-flanges of cylinder.

During the calculation of the crosshead it is necessary to examine all possible cases of loading. For example, for the three-cylinder forging press possible load cases are shown in Fig. 213.

During the calculation of lower cross-beam the load can be conditionally accepted evenly distributed by the length, equal to $\frac{1}{2}$, of the flight/span between the columns.

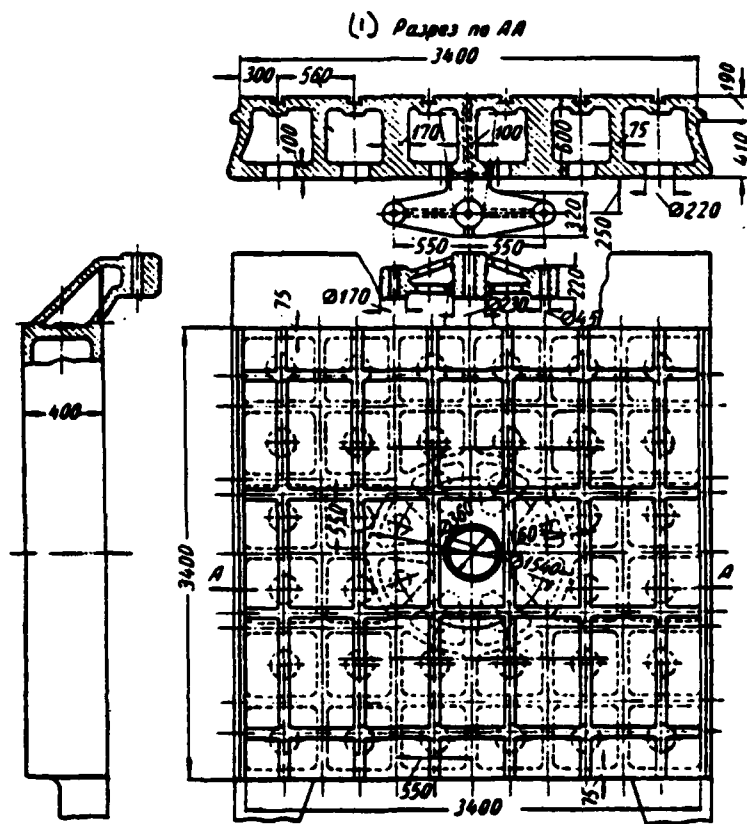

Fig. 209. Table of the forging press by effort/force 7000 t.

Key: (1). Section/cut on AA.

Page 200.

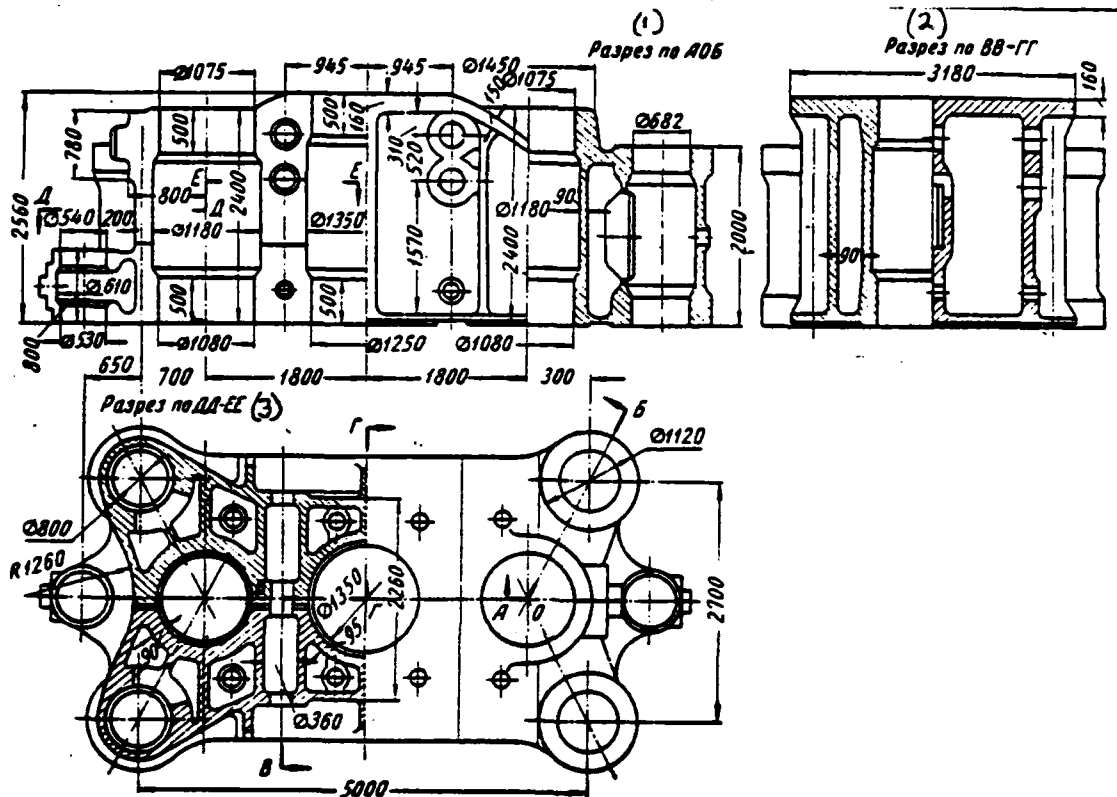

Fig. 210. Upper cross-beam of forging press by effort/force 7000 t.

Key: (1). Section/cut on the AOB. (2). Section/cut on BB-ГГ. (3). Section/cut on ДД-ЕЕ.

Page 201.

The working surfaces of the crosshead and bolster or lower cross-beam must also be checked to the warping; in this case the

allowable stresses are taken as equal to $\sigma=600-700$ kg/cm².

In the case of sharply concentrated load on the instrument (faces or dies/stamps) the length of span, loaded by uniform load, is counted, on the basis of the angle of the dispersion of load α , equal to approximately 36-38° (Fig. 214).

The edges/fins of cross-beams and table must be designed also for compression; in this case allowable stress should be accepted not more than 800 kg/cm².

The height/altitude of lower and upper cross-beam in the bearing edge of columns usually is set to the diameter of columns and they take as the equal to 2.5-3.5 of diameter of column.

The height/altitude of upper cross-beam in the sections/cuts throughout the site of installation of working cylinders they take as equal to 2.5-3.5 outside diameters of cylinder.

In the powerful/thick presses of cross-beam they frequently perform by the composite/compound, bolted. Design diagram for the composite/compound cross-beam is shown in Fig. 215.

The equation of equilibrium for this diagram will be

$$Ql = P_1 l_1 + P_2 l_2 + P_3 l_3.$$

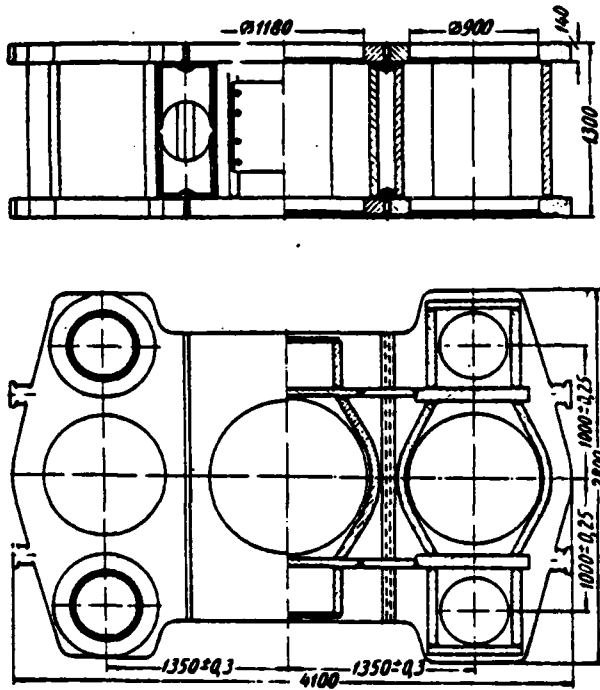

Fig. 211. Welded upper cross-beam of stamping machine by effort/force 3000 t (Uralmashzavod).

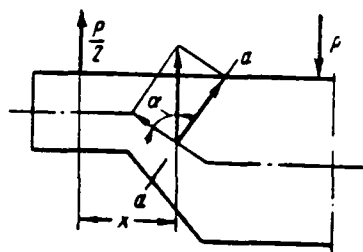

Fig. 212.

Fig. 212. Element/cell of the cross-beam of variable/alternating/variable section/cut.

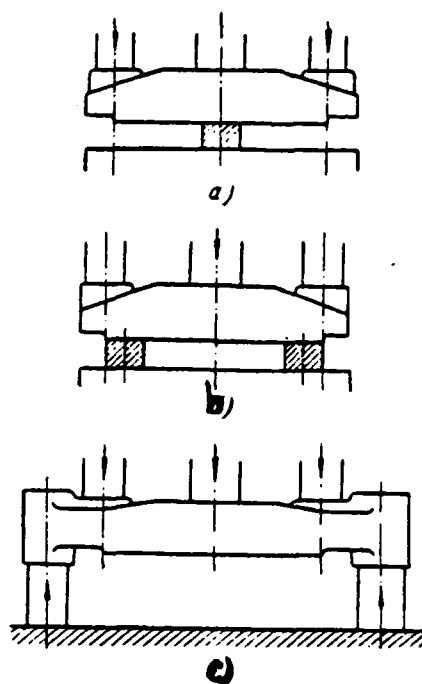

Fig. 213.

Fig. 213. The possible load cases of the crosshead of the three-cylinder forging press: a) cross-beam is loaded by two outer cylinders; support is arranged/located on the center of press; b) cross-beam is loaded by one pitch cylinder; supports are spread on the arm, whose value, for example, can be equal to the distance between the arm brackets during forging of ring; c) cross-beam is loaded by all cylinders and is based in this case on the travel limiters, assembled on the columns.

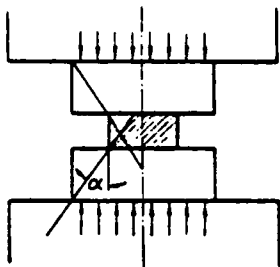

Fig. 214.

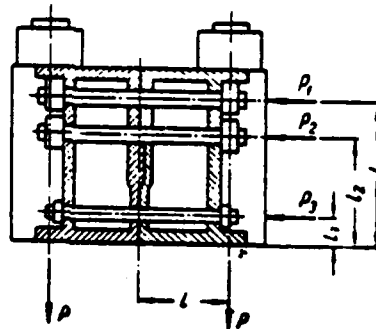

Fig. 215

Page 203.

The maximal stress/voltage in the tightening bolt (upper) is taken as equal to $\sigma_0 = 700 \text{ kg/cm}^2$.

The cross-sectional areas of tightening bolts (f) are chosen from the relationships/ratios

$$f_2 = f_1 \frac{l_2}{l_1}; \quad f_3 = f_1 \frac{l_3}{l_1}.$$

Then

$$Pl = \left(f_1 l_1 + \frac{f_1 l_2^2}{l_1} + \frac{f_1 l_3^2}{l_1} \right) \sigma_0;$$

$$Pl = \frac{f_1}{l_1} (l_1^2 + l_2^2 + l_3^2) \sigma_0.$$

According to this equation we determine the cross-sectional area of upper bolt and then cross-sectional area of remaining bolts.

Elements of Calculation for Fatigue.

The given in the previous sections procedures of calculation of cylinders and frames of hydraulic presses make it possible to determine power factors and, therefore, the stresses/voltages, which appear in the parts indicated. The obtained results are congruent/equate with the allowable stresses and on this basis are concluded about the efficiency of element/cell. However, even in the case, when the stresses/voltages obtained by calculation do not exceed those permitted, there is no complete guarantee, that in the process of operation the destruction of separate parts will not occur. It is necessary to keep in mind that the parts of hydraulic presses work in the conditions of alternating loads. Therefore the complete guarantee of strength it can give only calculation for the fatigue. At present there is not sufficiently complete data according to the calculation for the fatigue of large-size parts, which include the majority of the elements/cells of press. Therefore are given below only the general/common/total considerations, which it is necessary to keep in mind during the calculation of equipment.

As many-year practice and experimental research showed, the fatigue strength of parts depends on a whole series of reasons.

Very considerable effect on the fatigue limit proves to be the

heterogeneity of the stressed state. Thus, for instance, for the low-carbon steel the ratio of the fatigue limit with tension-compression to the flexing life is equal approximately/exemplarily to 0.8. The fatigue limit during the torsion composes 0.55 from the flexing life approximately.

As practice showed, with an increase in the absolute sizes/dimensions of part its fatigue strength is depressed. In connection with this for the large-size parts the limit, obtained during sample testing of low sizes/dimensions, it follows to lower by 20-30%.

For the parts of forging-and-pressing equipment the pulsing cycle is characteristic; therefore during the calculation one should be oriented to the fatigue limit with pulsating load.

Page 204.

Stress concentration is one of the reasons for the appearance of fatigue cracks. Data according to the efficient concentration factors are in the reference literature.

Since at present there is not sufficiently complete given, that consider all enumerated factors, during the calculation should be

accepted the following safety factors:

a) in the presence of the experimental data about the stresses/voltages in the part, obtained during model test, safety factor should be accepted $n=1.4-1.5$;

b) in the absence of experimental data stored up strength it must be increased: $n=1.5-1.7$.

Page 205.

Chapter 4.

Elements of the Calculation of Hydraulic Systems of Presses.

Fundamental calculated equations.

Hydraulic presses are the complex systems, in which all forms of the motion of liquid are encountered.

In view of the great variety of the hydro-diagrams of presses it is impossible to give calculation formulas for all cases.

The examination of the dynamics of press installations/settings up, carried out in the subsequent paragraphs, is limited to the most general cases; beyond their limits can be met the tasks, for solving which it is necessary to use the general/common/total equations of hydrodynamics.

In order that with the design and calculation of press with the use of this work to reduce to minimum turning to special courses, and to also facilitate understanding the material of the subsequent

chapters, we give the fundamental equations, which describe the one-dimensional motion of liquid, and the necessary information for the use of these equations.

Steady motion.

With the steady motion the liquids of pressure and speed at each point of flow do not vary in the time. With the smoothly changing section/cut of flow connection/communication between the speeds in different sections/cuts is determined from the equation of the constancy of fluid flow rate along the flow (equation of continuity):

$$W = v_1 F_1 = v_2 F_2 = \dots = v F = \text{const}, \quad (114)$$

where W - volume of the liquid, passing through the section/cut of flow;

F - cross-sectional area of flow;

v - average/mean rate of flow of liquid in this section/cut.

Let us note that this equation is correct for unsteady motion of liquid.

The connection between the speeds and the functioning pressures in different sections/cuts of flow can be obtained from the known equation of D. Bernoulli:

$$Z_1 + \frac{p_1}{\gamma} + \frac{v_1^2}{2g} = Z_2 + \frac{p_2}{\gamma} + \frac{v_2^2}{2g} = \text{const}, \quad (115)$$

where Z_1 and Z_2 - height/altitude of the arrangement of the centers of gravity of the sections/cuts of the flow above datum plane;

p_1 and p_2 - pressure in the centers of gravity of the sections/cuts of flow;

γ - the specific gravity/weight of liquid;

g - acceleration of gravity.

Using the equation of D. Bernoulli, let us consider the case of the steady flow of liquid on the conduit/manifold of constant diameter, connected to the tank, in which the constant pressure p_1 and the cross-sectional area of which is supported many times of more than the section/cut of conduit/manifold ($v_1/v_2 \approx 0$).

Let in exit section of conduit/manifold the constant pressure p_2 (Fig. 216) function. Then on the basis of the equation of D. Bernoulli we can write:

$$Z_1 + \frac{p_1 - p_2}{\gamma} = H = \frac{v^2}{2g}, \text{ or } v = \sqrt{2gH}. \quad (116)$$

The maximum value of speed, called by the pressure (without taking into account losses to the friction) functioning on the flow, is frequently called critical speed for this pressure.

The values of critical speeds for the pressures, used in hydraulic systems of presses are given in Fig. 217. Equations (115) and (116) are valid only for the ideal (not viscous) liquid, during the motion by which the speeds at any point of flow cross section are equal.

During the motion of the real (viscous) liquid of the speed in the section/cut of flow they will be different, which will change the value of the kinetic energy of the mass of liquid, which passes per unit time through the section/cut of flow.

The nonuniformity of speeds over the section/cut, flow is considered by Coriolis's coefficient (α), who has a value $\alpha=1.05-1.1$ and frequently in the calculations it lowers.

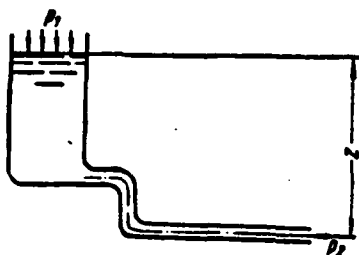

Fig. 216.

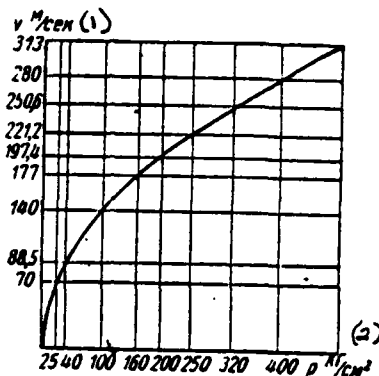

Fig. 217.

Fig. 217. The critical speeds of the flow of liquid in the dependence on pressure difference in its end sections/cuts.

Key: (1). m/s. (2). kg/cm².

Page 207.

Besides the account of the nonuniformity of the distribution of speeds over the section/cut of flow for the real liquid, it is necessary to take into account losses of head to the overcoming of the resistance, which let us designate through h_r .

Then equation (115) will take the form

$$Z_1 + \frac{p_1}{\gamma} + \frac{a_1 v_1^2}{2g} = Z_2 + \frac{p_2}{\gamma} + \frac{a_2 v_2^2}{2g} + h_r. \quad (117)$$

Losses of head to overcoming of friction in the straight/direct conduit/manifold.

These losses are determined from the formula

$$h_f = \lambda \frac{L}{d} \cdot \frac{v^2}{2g} \text{ m}, \quad (118)$$

where L - length of conduit/manifold m;

d - bore of conduit/manifold m.

Coefficient λ depends on many factors, in particular, from the speed of the motion of liquid, and therefore losses are not always proportional to the square of the speed of motion by the latter.

At the low average/mean rates of flow when the streamlined motion of liquid is retained, viscous motion), the diagram/curve of the relative rates of flow of liquid is the parabola:

$$\frac{v}{v_{\max}} = 1 - \left(\frac{r}{r_0}\right)^2 \quad (\text{Fig. 218}),$$

in which

$$v_{\max} = \frac{7h_f}{L \cdot 4\mu} r_0^2 \quad (119)$$

and the average/mean value of the speed

$$v_{cp} = 0,5v_{\max}, \quad (120)$$

where μ - coefficient of dynamic viscosity in $\text{kg}\cdot\text{s}/\text{m}^2$. Being congruent/equating values h_f from equation (118) and obtained from equation (119) and (120), we find

$$\lambda = \frac{64\mu g}{d^5 \gamma} = \frac{64\nu}{d^4 v} \quad (121)$$

or

$$\lambda = \frac{64}{\text{Re}} \quad (122)$$

where ν - kinematic modulus of viscosity;

Re - Reynolds number.

For the water with $t=10^\circ\text{C}$; $\nu=0.0131 \text{ cm}^2/\text{s}$.

From expressions (118) and (121) it follows that with laminar flow the losses of head to fluid friction against the conduit/manifold are proportional to the rate of flow in the first degree.

Laminar flow is retained with the Reynolds number

$$\text{Re} = \frac{v \cdot d}{\nu} < 2000.$$

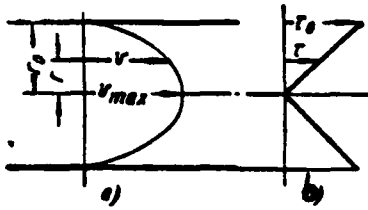

Fig. 218. Velocity diagram over the section/cut of flow (a) and diagram of the stresses/voltages of the forces of fluid friction (b).

Page 208.

In hydraulic presses the speeds of the motion of liquid in the conduits/manifolds are such, that in the overwhelming majority of the cases the turbulent flow conditions during which as a result of the displacement of the particles of the liquid the alignment/levelling the averaged speeds over the section/cut occurs occurs.

During the turbulent flow for the determination λ they use different empirical dependence. For the ducts/tubes/pipes with the rough surface with the quadratic dependence of losses to the friction on the speed of flow of Nikuradze is proposed the formula, according to which the losses do not depend on Reynolds number:

$$\lambda = \frac{1}{\left(21g \frac{d}{\Delta} + 1.14\right)^2}, \quad (123)$$

where Δ - conditional linear characteristic, determined

experimentally.

For the conduits/manifolds from the new drawn tubes the average/mean values of $\Delta=0.06-0.1$ mm; for the conduits/manifolds from the seamless and welded ones in the joint ducts/tubes/pipes during the insignificant corrosion $\Delta=0.2$ mm.

The values λ for the steel conduits/manifolds with $\Delta=0.2$ mm are given below:

d in mm	15	25	50	100	200	300	400	500	600	800	1000
λ	0.042	0.35	0.028	0.023	0.02	0.018	0.017	0.016	0.015	0.014	0.0137

Losses of head to overcoming of local resistance.

Local resistance (an abrupt change in the section/cut of conduit/manifold, rotations, fittings, valves, etc.) causes the additional losses, caused by vortex formation and change in the velocity fields in the section/cut of flow.

These losses are proportional to the square of the speed of flow and are determined from the formula

$$h_{\text{loc}} = \xi \frac{v^2}{2g} \text{ m.} \quad (124)$$

where v - average/mean rate of flow of liquid in the conduit/manifold

in m/s;

ξ - drag coefficient, depending on the geometry of local resistance, the flow pattern before the local resistance and of other factors.

During the practical calculations are conveniently local losses expressed as the length of conduit/manifold equivalent on the losses.

From the comparison of equations (124) and (118) we have

$$\xi = \lambda \frac{L}{d}. \quad (125)$$

Equivalent on the losses length of the conduit/manifold

$$L = \frac{\xi}{\lambda} d. \quad (126)$$

Page 209.

Coefficient ξ is determined experimentally and for the high values of Reynolds number ($Re > 15000$) on it virtually does not depend.

Let us represent formula (124) in another form:

$$v = \sqrt{\frac{1}{\xi} 2gh_{\text{loss}}} = \sqrt{\frac{1}{\xi}} \sqrt{2gh_{\text{loss}}} = \varphi \sqrt{2gh_{\text{loss}}}. \quad (127)$$

Expression $\sqrt{\frac{1}{\xi}}$, usually designated through φ , is called speed factor.

Value $h_{\text{min}} = h$ shows the necessary pressure before any element/cell of hydraulic system, which proves to be local flow resistance, for the creation of given speed of the course of the liquid through this element/cell.

The coefficients of local resistance for different elements/cells are given in the reference literature on hydrodynamics [16]. We give below values ξ for some elements/cells of the networks/grids of hydraulic press installations/settings up.

For the forged steel bored/squandered angle plates the values of coefficients ξ are given on the graph Fig. 219. For the angular check valves the values ξ are given on the graph Fig. 220 and for the direct-flow/ramjet check valves - on the graph Fig. 221.

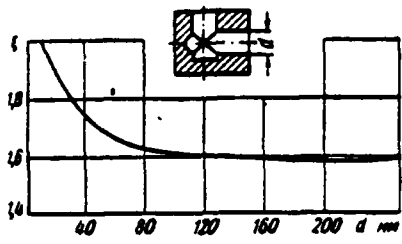

Fig. 219.

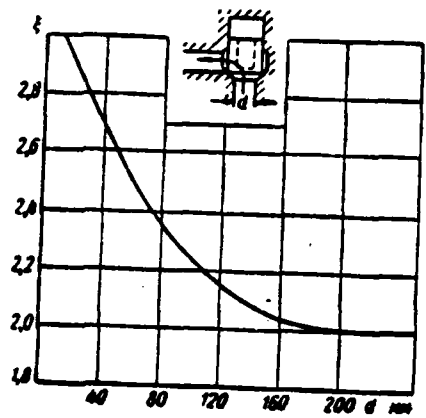

Fig. 220.

Fig. 219. Values of coefficient ξ for the forged steel bored/squandered angle plates.

Fig. 220. Values ξ for the angular check valves.

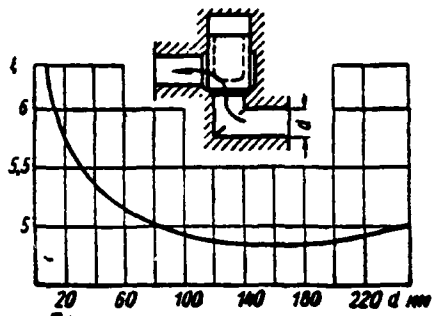

Fig. 221.

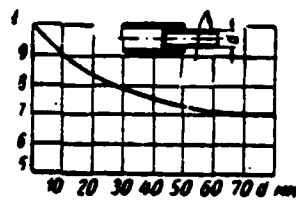
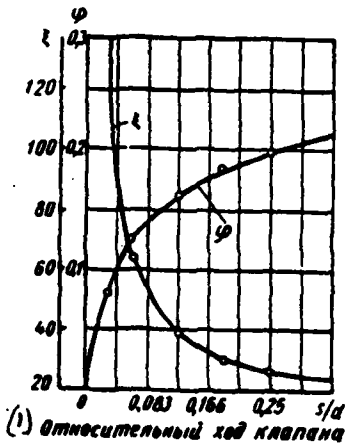
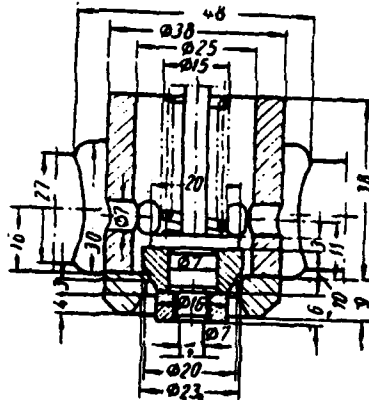
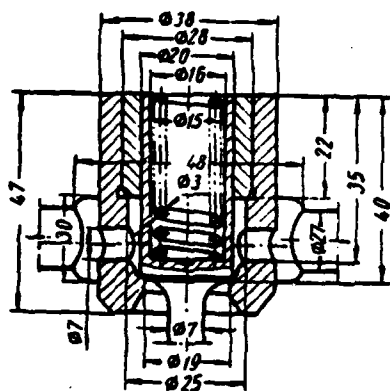

Fig. 222.

Fig. 221. Values ξ for the direct-flow/ramjet check valves.

Fig. 222. Values ξ for swivel joints of conduits/manifolds.



(1) Относительный ход клапана

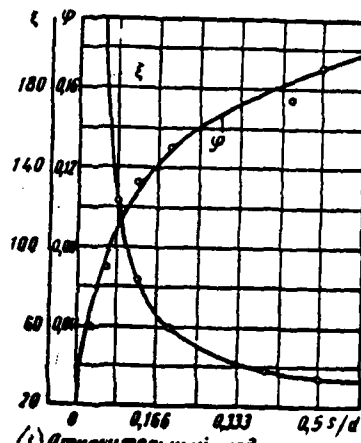

(1) Относительный ход клапана

Fig. 223.

Fig. 224.

Fig. 223. Dependences $\xi=f(s/d)$ and $\phi=f(s/d)$ for the controlled valve.

Key: (1). Relative valve travel.

Fig. 224. Dependence $\xi=f(s/d)$ and $\phi=f(s/d)$ for the throttle valve.

Key: (1). Relative valve travel.

Page 211.

Drag coefficients ξ for swivel joints of conduits/manifolds can be accepted on the graph Fig. 222.

Drag coefficients ξ and speed factors for some valves of the specific sizes/dimensions are given in Fig. 223-225.

For the three- and fourway valve distributors with the spindle equilibrated valves with diameters of 12-130 mm $\xi=14$, with disc valves with diameters of 12-150 mm $\xi=16$.

Unsteady motion of inelastic liquid.

With the unsteady flow, i.e., when its speed are changed in the time, are exhibited the inertial force, whose value (if one assumes that liquid and the conduit/manifold, over which it moves, they are not elastic) for the rectilinear conduit/manifold of constant section F and finite length L' it is equal to

$$ma = \frac{\gamma FL'}{g} \cdot \frac{dv}{dt}.$$

Respectively inertia pressure is equal to

$$h_u = \frac{L'}{g} \cdot \frac{dv}{dt}. \quad (128)$$

Taking into account inertia pressure equation (117) takes the form

$$Z_1 + \frac{p_1}{\gamma} + \frac{a_1 v_1^2}{2g} = Z_2 + \frac{p_2}{\gamma} + \frac{a_2 v_2^2}{2g} + h_r \pm \frac{L' \cdot dv}{g \cdot dt} \quad (129)$$

Inertia pressure has the positive value with the increase of velocity ($dv/dt > 0$), i.e., upon the dispersal/acceleration of flow, and the negative value during the delay/retarding/deceleration of flow ($dv/dt < 0$).

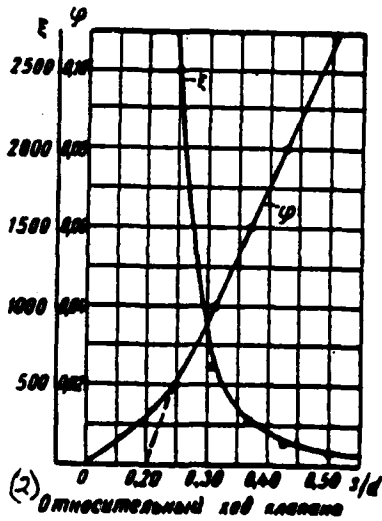
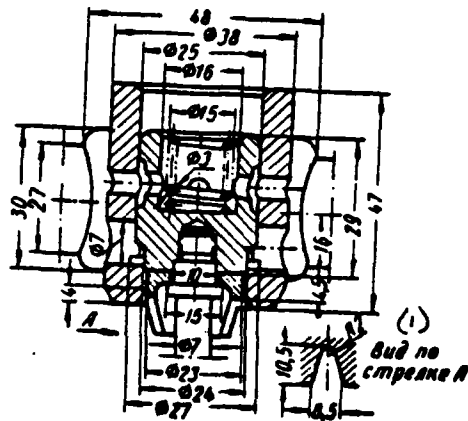

Fig. 225. Dependence $\xi=f(s/d)$ and $\phi=f(s/d)$ for the throttle valve with the "cup".

Key: (1). View along the arrow A. (2). Relative valve travel.

In the case of the attachment/connection of the conduit/manifold of constant section to the reservoir of great capacity, in which the liquid is located under constant pressure H (see Fig. 216), equation (129), if we drop/omit Coriolis's coefficients, accepts the form

$$Z + \frac{p_1 - p_2}{\gamma} = H = \frac{v^2}{2g} + \lambda \frac{L}{d} \cdot \frac{v^2}{2g} \pm \frac{L'}{g} \cdot \frac{dv}{dt}, \quad (130)$$

where $L = L' + (\xi/\lambda)d$ according to equation (126).

From equation (130) it follows that the velocity of liquid in the conduit/manifold increases in the time, approaching the value

$$v = \sqrt{\frac{2gH}{1 + \lambda \frac{L}{d}}}. \quad (131)$$

Velocity change can be found with the integration of equation (130).

Let us designate

$$H = c; \quad \frac{1}{2g} \left(1 + \lambda \frac{L}{d}\right) = b; \quad \pm \frac{L'}{g} = a.$$

With these designations equation (130) will be written in the form

$$a \frac{dv}{dt} + bv^2 - c = 0. \quad (132)$$

In this case it is assumed that λ does not depend on velocity.

Let us write equation (132) in the form

$$\frac{dv}{\frac{c}{a} - \frac{b}{a} v^2} = dt.$$

The left side of this expression is the tabular integral, solution of which it is

$$t = \frac{a}{2\sqrt{bc}} \ln \frac{\sqrt{\frac{c}{b}} + v}{\sqrt{\frac{c}{b}} - v} + C, \quad (133)$$

where C - integration constant, which is found from the initial conditions: with $t=0$, $v=0$, $C=0$.

Equation (133) can be converted to the form

$$v = \sqrt{\frac{c}{b}} \left(1 - \frac{2}{e^{\frac{2\sqrt{cb}}{a}t} + 1} \right). \quad (134)$$

Thus was obtained the expression of the instantaneous value of the velocity of flow in the period of unsteady motion v as a function of time t .

Page 213.

Calculation of complicated conduits/manifolds.

Let us consider the cases of the feeding of conduit/manifold of the tank of great capacity, in which constant pressure is supported.

Let us assume that the drag coefficient of conduit/manifold λ does not depend on Reynolds number (conduit/manifold with the rough

surface).

For the solution of problems we use equations (117) and (130).

Series connection of the conduits/manifolds of different diameters (Fig. 226). For the steady motion

$$\frac{p_0 - p_1}{\gamma} + Z = \frac{v_1^2 d_1^4}{2g} \sum_{i=1}^{i=n} \left(\frac{1}{d_i^4} + \lambda_i \frac{L_i}{d_i^5} \right). \quad (135)$$

where $L_i = L_i + L_i^*$;

L_i - length of the straight/direct section of conduit/manifold;

L_i^* - length of conduit/manifold, equivalent on the losses to the local resistance, arranged/located in the appropriate section;

$$Z = Z_0 - Z_1.$$

For the case of the feeding of conduit/manifold by the pump of the constant supply, equal to $v_1 \cdot \frac{\pi d_1^2}{4}$, in equation (135) p_0 will indicate pressure in the flange of pump.

For unsteady motion

$$\begin{aligned} \frac{p_0 - p_1}{\gamma} + Z &= \frac{v_1^2 d_1^4}{2g} \sum_{i=1}^{i=n} \left(\frac{1}{d_i^4} + \lambda_i \frac{L_i}{d_i^5} \right) \pm \\ &\pm \frac{d_1^2}{g} \sum_{i=1}^{i=n} \frac{L_i}{d_i^2} \cdot \frac{dv_1}{dt}. \end{aligned} \quad (136)$$



Fig 226

Page 214.

Respectively the coefficients of equation (132) will be equal to

$$a = \pm \frac{d_1^2}{g} \sum_{i=1}^{i=n} \frac{L_i}{d_i}; \quad (137)$$

$$b = \frac{d_1^4}{2g} \sum_{i=1}^{i=n} \left(\frac{1}{d_i^4} + \lambda_i \frac{L_i}{d_i^5} \right); \quad (138)$$

$$c = \frac{p_0 - p_1}{\gamma} + Z. \quad (139)$$

In the given equations it is accepted that λ depends only on the diameter of conduit/manifold.

Branched conduit/manifold.

The equality of pressures at the nodes of conduit/manifold and the equality of the flow rate of the liquid flowing to the node to the flow rate of the liquid ebbing from it is initial position for calculating the branched conduit/manifold. For an example let us

consider the calculation of conduit/manifold according to the diagram in Fig. 227.

Steady motion. Let us write the flow equations for the individual sections of the conduit/manifold:

$$\frac{p_A - p_0}{\gamma} + Z_{A,0} = \frac{v_0^2}{2g} \left(1 + \lambda_0 \frac{L_0}{d_0} \right), \quad (140)$$

where $Z_{A,0} = Z_A - Z_0$;

$$\frac{p_0 - p_l}{\gamma} + Z_{0,l} = \frac{v_l^2}{2g} \left(1 + \lambda_l \frac{L_l}{d_l} \right) - \frac{v_0^2}{2g}, \quad (141)$$

where $Z_{0,l} = Z_0 - Z_l$,

whence

$$\frac{p_0}{\gamma} = \frac{1}{n} \sum_{i=1}^{i=n} \left[\frac{p_l}{\gamma} - Z_{1,i} + \frac{v_l^2}{2g} \left(1 + \lambda_l \frac{L_l}{d_l} \right) \right] - \frac{v_0^2}{2g}. \quad (142)$$

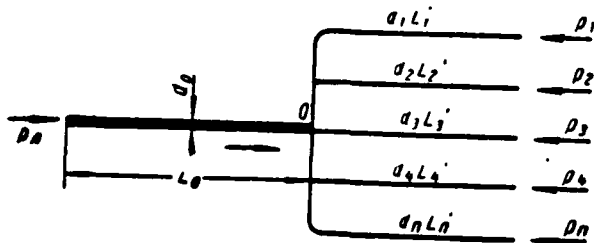

Fig. 227.

Page 215.

According to the equation of the continuity

$$v_0 = \frac{\sum_{i=1}^{i=n} v_i d_i^2}{d_0^2}$$

The diameters of the conduits/manifolds of separate branches are determined from the formula

$$d_i = \sqrt{\frac{4W_i}{\pi v_i}}$$

where W_i - fluid flow rate on the appropriate branch conduit.

Usually during the design of new conduit/manifold known values they are:

$p_0, p_1, p_2, \dots, p_n$ - pressure in the supply of power (storage battery/accumulator or filler tank) and sources of consumption

(pressure cylinders);

W_0, W_1, \dots, W_n - flow rates on the branched pipes (consumption of liquid by pressure cylinders);

$Z_0, Z_1, Z_2, \dots, Z_n$ - high-altitude pressures;

$L_0, L_1, L_2, \dots, L_n$ - length of conduits/manifolds (including the lengths, equivalent on the losses of head to the local resistance, established/installed in each section).

The velocities in conduits/manifolds v_1, v_2, \dots, v_n accept according to experimental data.

Calculation in this case is reduced to the determination from the written equations of the diameter of the unbranched conduit/manifold d_0 , and the velocity v_0 of flow of liquid in this conduit/manifold.

In this case the coefficient λ_0 can be determined according to tables 18 in terms of the value of the diameter, determined according to the formula

$$d_0 = \sqrt{\sum_{i=1}^{i=n} d_i^2}.$$

of that written from the assumption of the equality of the velocities in all lines of drainage system.

In the practice of the calculation of the drainage systems of press the cases of branching off the conduit/manifold to the equally arranged/located branches of equal diameters and lengths with the equal pressures in the end sections/cuts most frequently are encountered, in this case $p_A, p_i, Z_A, Z_i, L_0, L_i, W_0$ are known values

The diameters of conduits/manifolds in this case are determined as follows: taking v_0 as the equal to v_i , we will obtain

$$d_1 = \frac{(\lambda_0 L_0 + \sqrt{n} \lambda_1 L_1) \gamma v_1^2}{\sqrt{n} [(p_A - p_i) - (Z_A - Z_i) \gamma] 2g - v_1^2 \gamma}; \quad (143)$$

$$d_0 = \sqrt{n} \cdot d_1,$$

where n - number of branchings off.

Page 216.

Coefficients λ_0 and λ_1 can be selected in terms of values of d'_0 and d'_1 , determined from the prescribed/assigned flow rate and the velocity $v_0 = v_1$ adopted:

$$d'_0 = \sqrt{\frac{4W_0}{\pi v_0}}; \quad d'_1 = \sqrt{\frac{4W_1}{\pi v_1}}$$

Unsteady motion. Flow equations for the individual sections:

$$\frac{p_A - p_0}{\gamma} + Z_{A,0} = \frac{v_0^2}{2g} \left(1 + \lambda_0 \frac{L_0}{d_0} \right) \pm \frac{L_0'}{g} \cdot \frac{dv_0}{dt}; \quad (144)$$

$$\frac{p_0 - p_i}{\gamma} + Z_{0,i} = \frac{v_i^2}{2g} \left(1 + \lambda_i \frac{L_i}{d_i} \right) \pm \frac{L_i'}{g} \cdot \frac{dv_i}{dt} - \frac{v_0^2}{2g}. \quad (145)$$

For determining the booster duration of flow from equation (132), in the case of branching off the conduit/manifold to the equally arranged/located branches of equal diameters and lengths with the equal pressures in the end sections/cuts and the equal velocities of steady motion in all sections of conduit/manifold, value of coefficients of a, b and c they take the form

$$a = \pm \frac{L_0' + L_i'}{g}; \quad (146)$$

$$b = \left[1 + \frac{1}{d_i} \left(\frac{\lambda_0 L_0}{\sqrt{n}} + \lambda_i L_i \right) \right] \frac{1}{2g}; \quad (147)$$

$$c = \frac{p_A - p_i}{\gamma} + (Z_{A,0} + Z_{0,i}). \quad (148)$$

Impact Pressures in a Hydraulic System.

With an abrupt change of the fluid flow rate in the conduit/manifold of finite length (for example, with rapid valve overlap or catch or with hitch of plunger), as a result of the exhibited inertial forces within the liquid, the alternating waves of the increased and reduced pressure, which extend along the conduit/manifold, appear. This phenomenon, called "hydraulic impact", is discovered by the blind/dead/deaf sound and the jolt of conduit/manifold.

Considerable pressure increases of liquid, and also jolt of conduit/manifold lead to the disorder of its compounds, and sometimes also to the breakage of conduit/manifold itself.

Therefore, during the design of the hydraulic system of press is necessary the explanation of the possible cases of a sharp increase in pressure and acceptance of the measures, which warn this increase.

Page 217.

The examination of unsteady motion of liquid along the conduit/manifold (Fig. 228) taking into account the elasticity of liquid and walls of conduit/manifold, but without taking into account losses of head to the friction, reduces to the general/common/total equations, which link pressure and velocity in any section/cut of conduit/manifold from the arbitrary form of the function Φ and f from the independent variables - coordinates x time t :

$$H - H_0 = \Phi\left(t - \frac{x}{a}\right) + f\left(t + \frac{x}{a}\right); \quad (149)$$

$$v - v_0 = -\frac{g}{a} \Phi\left(t - \frac{x}{a}\right) + \frac{g}{a} \left(t + \frac{x}{a}\right). \quad (150)$$

The equations, for the first time obtained by N. Ye. Zhukovskiy, make it possible to solve problems in hydraulic impact [17].

These equations make simple physical sense, which consists of the following; function $\Phi(t-x/a)$ retains constant value, if only simultaneously with an increase in time t by Δt the abscissas they will increase by $a\Delta t$.

Hence it follows that $\Phi(t-x/a)$ it is pressure wave, moving in the direction x (direct wave) at a rate of a . Analogously function $f(t+x/a)$ is pressure wave, moving in the opposite direction (backward wave), also. From equation (149) it follows that at each moment/torque the value of impact pressure $\Delta H = H - H_0$ is equal to the sum of pressures by straight line and that reflected of waves. The values of arbitrary functions Φ and f are determined from the initial and boundary conditions of task.

Let us return to the design diagram Fig. 228 and let us assume $x=L$. According to this diagram, during closing of valve from section/cut mn will leave and extend along the conduit/manifold the shock waves, determined by function $\Phi(t-x/a)$. After the time, when $\theta=L/a$, impact pressure is spread on entire conduit/manifold and at the subsequent moment/torque, i.e., in some time, equal to $t=\theta+\Delta t$, will be equally $\Phi(\theta+\Delta t-\theta) = \Phi(\Delta t)$. But since pressure in tank constantly is equal H_0 , pressure in the section/cut will prove to be

unbalanced, in consequence of which the liquid in the section/cut in tank will change direction of motion, and from this section/cut issues a backward wave of negative pressure, equal $f(\Delta t) = -xF(\Delta t)$.

Let us assume that the time of the coverage of valve $t, < (2L/a)$, then the opposite (reflected from the tank) wave up to the moment/torque of the complete closing of valve will not have time to reach to section/cut mn and impact pressure in it will be determined by one function $\Phi(t)$.

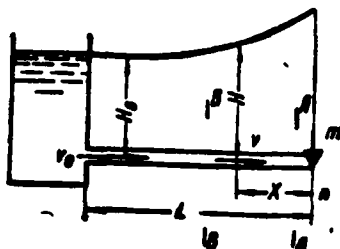

Fig. 228.

Page 218.

According to equation (149) $H - h_0 = xF(t)$ and equation (150) $v_0 = g/ax\Phi(t)$ (since occurred the complete closing of valve and, therefore, $v=0$).

Excluding from these expressions $\Phi(t)$, we find

$$H - H_0 = \Delta H = \frac{av_0}{g}. \tag{151}$$

Thus was obtained the known formula of N. Ye. Zhukovskiy, according to which is determined the limiting value of the impact pressure, which occurs when the time of closing valve is less than the period of conduit/manifold, equal to $\tau = (2L/a)$ (direct impact).

If the time of the coverage of valve $t > \tau$, then in section/cut mn from the moment/torque of time $t = (2L/a) = \tau$ will function two waves: the straight line, determined by function Φ , and reverse/inverse, determined by function f . In this case $f(t)_{(n+1)\tau} = -\Phi_{n\tau}(t - \tau)$, where n - ordinal number of phase.

For calculating the hydroshock to more conveniently have equations, which link pressures and velocities in two adjacent sections/cuts. Such equations it is easy to obtain from equations (149) and (150), after writing the latter for two adjacent sections/cuts, for example for sections/cuts AA and BB, according to Fig. 228.

Let for certain moment/torque of time t the values $\Phi(t)$ and $f(t)$ in section/cut AA be known. Then according to equations (149) and (150) it is possible to write:

$$\left. \begin{aligned} H_t - H_0 &= \Phi^A(t) + f^A(t); \\ v_t^A - v_0 &= -\frac{g}{a} \Phi^A(t) + \frac{g}{a} f^A(t). \end{aligned} \right\} \quad (152)$$

For section/cut BB analogous expressions for the moment/torque of the time

$$t + \frac{L_{AB}}{a} = t + \theta;$$

will take the form

$$\left. \begin{aligned} H_{t+\theta}^B - H_0 &= \Phi^B(t + \theta) + f^B(t + \theta); \\ v_{t+\theta}^B - v_0 &= -\frac{g}{a} \Phi^B(t + \theta) + \frac{g}{a} f^B(t + \theta). \end{aligned} \right\} \quad (153)$$

However, since $\Phi_t^A = \Phi^B(t + \theta)$, then from equations (152) (153), beginning with $t=0$, we can obtain:

$$\left. \begin{aligned}
 H_0^A - H_0^B &= \frac{a}{g} (v_0^A - v_0^B); \\
 H_0^A - H_{2\theta}^B &= \frac{a}{g} (v_0^A - v_{2\theta}^B); \\
 \dots & \\
 H_{(n-1)\theta}^A - H_{n\theta}^B &= \frac{a}{g} (v_{(n-1)\theta}^A - v_{n\theta}^B).
 \end{aligned} \right\} \quad (154)$$

Page 219.

If at some moment of time are known $\Phi^B(t)$ and $f^B(t)$, then it is possible to write:

$$\left. \begin{aligned}
 H_t^B - H_0 &= \Phi^B(t) + f^B(t); \\
 v_t^B - v_0 &= -\frac{g}{a} \Phi^B(t) + \frac{g}{a} f^B(t).
 \end{aligned} \right\} \quad (155)$$

For section/cut AA up to the moment/torque of time $t+\theta$ we have

$$\left. \begin{aligned}
 H_{t+\theta}^A - H_0 &= \Phi^A(t+\theta) + f^A(t+\theta); \\
 v_{t+\theta}^A - v_0 &= -\frac{g}{a} \Phi^A(t+\theta) + \frac{g}{a} f^A(t+\theta).
 \end{aligned} \right\} \quad (156)$$

However, since $f^A(t+\theta) = f^B(t)$, then from equations (155) and (156), beginning with $t=0$, we will obtain

$$\left. \begin{aligned}
 H_0^B - H_0^A &= -\frac{a}{g} (v_0^B - v_0^A); \\
 H_0^B - H_{2\theta}^A &= -\frac{a}{g} (v_0^B - v_{2\theta}^A); \\
 \dots & \\
 H_{(n-1)\theta}^B - H_{n\theta}^A &= -\frac{a}{g} (v_{(n-1)\theta}^B - v_{n\theta}^A).
 \end{aligned} \right\} \quad (157)$$

Obtained equations (154) and (157) can be converted into the

relative dimensionless quantities.

Let us introduce the designations:

$$h = \frac{H}{H_0}; \quad u = \frac{v}{v_{\max}}; \quad \mu = \frac{w_{\max}}{2gH_0}.$$

Then the equations obtained previously take the following form:

$$h_{(n-1)0}^A - h_{n0}^B = 2\mu (u_{(n-1)0}^A - u_{n0}^B); \quad (158)$$

$$h_{(n-1)0}^B - h_{n0}^A = -2\mu (u_{(n-1)0}^B - u_{n0}^A). \quad (159)$$

In these equations index n indicates ordinal number of half-phase of impact/shock.

These equations let us lead to even the more general view, after replacing in them u by $w = \frac{V}{V_{\max}}$ - relative flow rate and respectively μ on $\mu = \frac{uV_{\max}}{2gH_0F}$, where V_{\max} - initial total flow rate, passed by the entire system in question;

F - cross-sectional area of the conduit/manifold between sections/cuts AA and BB.

Thus we will obtain

$$h_{(n-1)0}^A - h_{n0}^B = 2\rho_{AB} (w_{(n-1)0}^A - w_{n0}^A); \quad (160)$$

$$h_{(n-1)0}^B - h_{n0}^A = -2\rho_{AB} (w_{(n-1)0}^B - w_{n0}^A). \quad (161)$$

Wave propagation velocity of impact/shock.

Impact pressure extends on the conduit/manifold at a velocity, determined by the expression

$$a = \sqrt{\frac{gE}{\gamma}} \approx 1300 + 1400 \text{ m/s,}$$

where E is the bulk modulus of elasticity of the liquid, included in the conduit/manifold, taking into account the deformation of the walls of conduit/manifold.

In the practice usually it is necessary to deal concerning the conduits/manifolds, concerning the changing along the length diameters or wall thickness.

In such conduits/manifolds the average/mean rate of flow of liquid (v) and the velocity of propagation of elastic wave (a) along the length of conduit/manifold are changed, and this means that is changed also μ and occurs the partial reflection of the waves of impact/shock.

For practical purposes sufficiently exact solution is obtained, if we take along the length averaged values of v and a , determined as follows:

$$v = \frac{\sum v_i l_i}{L};$$
$$a = \frac{L}{\sum \frac{l_i}{a_i}},$$

where v_i and a_i - rate of flow and velocity of propagation of elastic wave for each section of the conduit/manifold with a length of l_i ;

L - overall length of conduit/manifold.

Impact pressures in a cylinder.

Let us consider the case of the abrupt deceleration of transfer plunger to its complete stop.

Let us produce calculation for the press, fed from the pneudraulic storage battery/accumulator. Design diagram is shown in Fig. 229.

Let us take the designations:

a_{AB} and a_{BC} - velocities of propagation of shock waves respectively in the cylinder and the conduit/manifold;

p_{AB} and p_{BC} - percussive characteristics respectively of

cylinder and conduit/manifold;

$$\rho_{AB} = \frac{a_{AB}W}{2gH_0F_{AB}}; \quad \rho_{BC} = \frac{a_{BC}W}{2gH_0F_{BC}},$$

where W - consumption of liquid by cylinder up to the moment/torque of the beginning of braking plunger; $W=v_0F$;

H_0 - pressure in the storage battery/accumulator in the meters of the water column;

θ_{AB} and θ_{BC} - time of landing run by the shock wave respectively of cylinder and conduit/manifold;

$$\theta_{AB} = \frac{l_{AB}}{a_{AB}}; \quad \theta_{BC} = \frac{l_{BC}}{a_{BC}}.$$

Page 221.

For the solution of problem we will use equations (160) and (161).

Let us write equation (161) from B_{0AB} to A_{20AB} :

$$h_{20AB}^H - h_{20AB}^A = -2\rho_{AB}(w_{10AB}^B - w_{20AB}^A). \quad (162)$$

In section/cut B at the moment of time θ_{AB} , $w_{10AB}^B = 1$ and $h_{10AB}^B = 1$, while in section/cut A, since we consider that the plunger stopped instantly, $w_{10AB}^A = 0$. After substituting these values in equation (162), we will obtain

$$h_{20AB}^A = 2\rho_{AB} + 1. \quad (163)$$

Let us further write equation (160) from $A_{30_{AB}}$ to $B_{30_{AB}}$:

$$h_{30_{AB}}^A - h_{30_{AB}}^B = 2\rho_{AB}(w_{30_{AB}}^A - w_{30_{AB}}^B); \quad (164)$$

$$h_{20_{AB}}^A = h_{30_{AB}}^B - 2\rho_{AB}w_{30_{AB}}^B. \quad (165)$$

Let us write the second equation from C. to $B_{30_{AB}}$, assuming that $30_{AB} < \theta_{BC}$:

$$h_0^C - h_{30_{AB}}^B = -2\rho_{BC}(w_0^C - w_{30_{AB}}^B). \quad (166)$$

Since $h_0^C = 1$ and $w_0^C = 1$,

$$2\rho_{BC} = h_{30_{AB}}^B + 2\rho_{BC}w_{30_{AB}}^B - 1; \quad (167)$$

From expressions (165) and (167) we find

$$w_{30_{AB}}^B = \frac{2\rho_{BC} - h_{20_{AB}}^A + 1}{2\rho_{AB} + 2\rho_{BC}}. \quad (168)$$

Analogously we find

$$h_{40_{AB}}^A = h_{50_{AB}}^B - 2\rho_{AB}w_{50_{AB}}^B; \quad (169)$$

$$2\rho_{BC} = h_{50_{AB}}^B + 2\rho_{BC}w_{50_{AB}}^B - 1; \quad (170)$$

$$w_{50_{AB}}^B = \frac{2\rho_{BC} - h_{40_{AB}}^A + 1}{2\rho_{AB} + 2\rho_{BC}}; \quad (171)$$

$$h_{50_{AB}}^A = h_{50_{AB}}^B + 2\rho_{AB}w_{50_{AB}}^B \quad \text{H T. Д.} \quad (172)$$

Key: (1). and so forth.

After the moment/torque, when $i = \theta_{AB} + \theta_{BC}$, at point C flow rate $\neq 1$. This varies the form of formula $w_{i0_{AB}}^B$ for $i > \theta_{AB} = 2(\theta_{AB} + \theta_{BC})$.

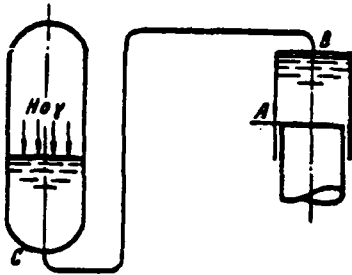

Fig. 229.

Page 222.

The values of pressures in section/cut A for $t > n_{AB}$ are determined by the solution of equations (160) and (161), comprised for each subsequent moment of time:

$$h_{n_{AB}}^A - h_{(n+1)_{AB}}^B = 2\rho_{AB} (\omega_{n_{AB}}^A - \omega_{(n+1)_{AB}}^B); \quad (173)$$

$$h_{n_{AB}}^A = h_{(n+1)_{AB}}^B - 2\rho_{AB} \omega_{(n+1)_{AB}}^B.$$

Equation from $C_{(n+1)_{AB-BC}}$ to $B_{(n+1)_{AB}}$ will take the form

$$h_{(n+1)_{AB-BC}}^C - h_{(n+1)_{AB}}^B = -2\rho_{BC} (\omega_{(n+1)_{AB-BC}}^C - \omega_{(n+1)_{AB}}^B); \quad (174)$$

$$2\rho_{BC} \omega_{(n+1)_{AB-BC}}^C = h_{(n+1)_{AB}}^B + 2\rho_{BC} \omega_{(n+1)_{AB}}^B - 1.$$

For the determination of $\omega_{(n+1)_{AB}}^B$ is necessary one additional equation:

$$h_{(n+1)_{AB-BC}}^B - h_{(n+1)_{AB-BC}}^C = 2\rho_{BC} (\omega_{(n+1)_{AB-BC}}^B - \omega_{(n+1)_{AB-BC}}^C); \quad (175)$$

From these equations we obtain

$$w_{(n+1)AB}^B = - \frac{h_{nAB}^A + h_{(n+1)AB}^B - 2p_{BC} w_{(n+1)AB}^B - 2p_{BC} w_{(n+1)AB}^B - 2}{2p_{AB} + 2p_{BC}}. \quad (176)$$

Knowing $w_{(n+1)AB}^B$ and $h_{(n+1)AB}^B$, we determine

$$h_{(n+2)AB}^A = h_{(n+1)AB}^B + 2p_{AB} w_{(n+1)AB}^B \text{ and so forth} \quad (177).$$

Consecutive by calculations it is possible to determine all following values h^A .

The problem examined about the hydraulic impact in the cylinder is easily solved graphically (Fig. 230), if relation $\frac{\theta_{AB} + \theta_{BC}}{\theta_{AB}}$ is small

For this we set aside along the axis of ordinates relative values of impact pressure h , and along the axis of abscissas - relative values of flow rate w .

At zero time in sections/cuts A, B and C $h=1$ and $w=1$. let us plot the regime points A_0 , B_0 , C_0 along the axis of abscissas.

In section/cut B the fluid flow rate and pressure $w^B = 1$, $h^B = 1$ are retained during the period of time, equal to $t = \theta_{AB}$, t.e. $w_{\theta_{AB}}^B = 1$;
 $h_{\theta_{AB}}^B = 1$.

In section/cut A the velocities according to the condition are equal to zero for any moment of time; therefore all values w^A are equal to zero and, thus, corresponding values h^A will be placed on the axis/axle of ordinates.

Page 223.

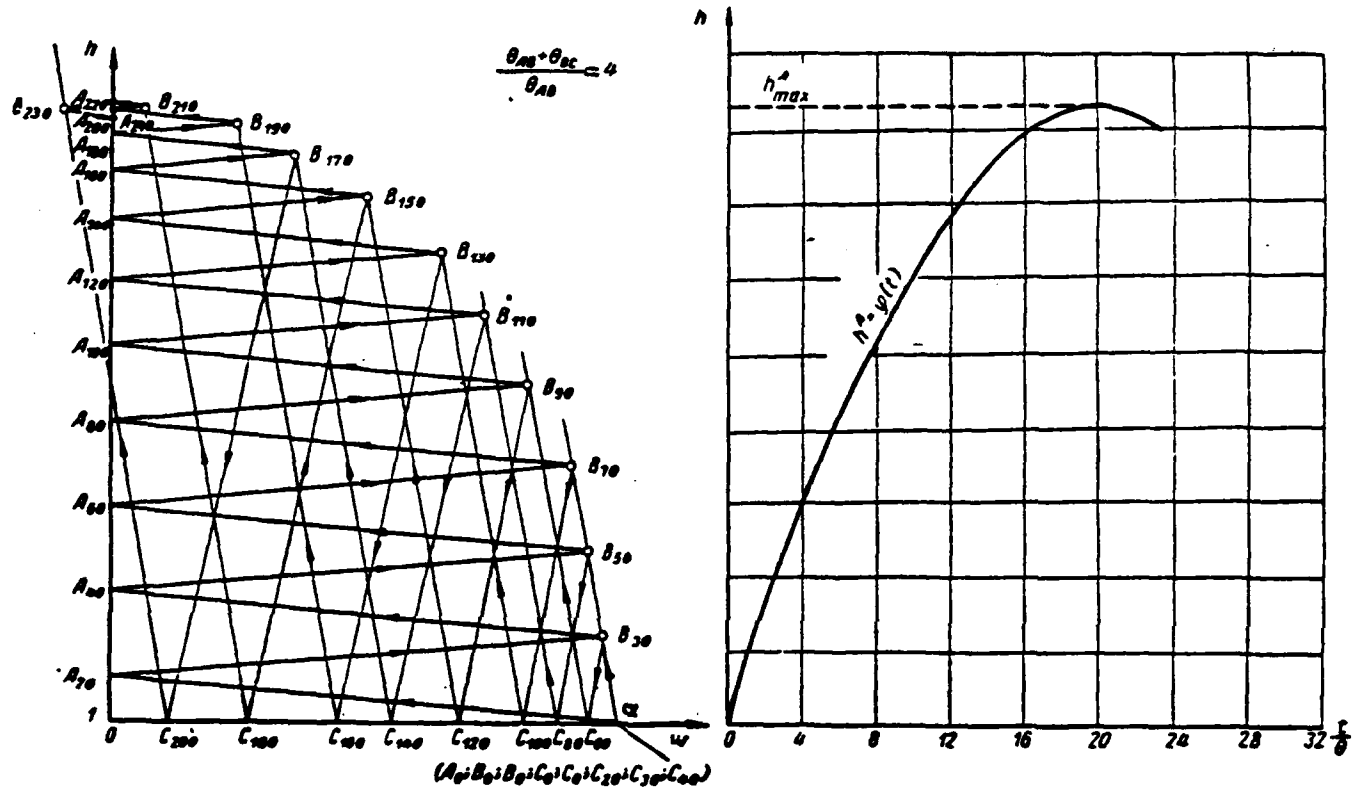

Fig. 230. The graphical solution of the task about the direct impact in the cylinder.

end section.

Page 224.

Expression (162) written previously for determination of h_{20}^A , represents the equation of the straight line, passing through two points: A_{20}^A and B_{0}^A .

The inclination/slope of this straight line to the axis/axle of abscissas is equal to $\text{tg } \beta = -2\rho_{AB}$. Intersection with this straight line with the axis/axle of ordinates gives regime point $A_{20}^A(h_{20}^A; \omega_{20}^A)$. We further carry out the straight line through expression (165), which leaves from point A_{20}^A with the inclination/slope toward the axis/axle of abscissas, determined from $\text{tg } \beta_1 = 2\rho_{AB}$. From point C, we carry out the straight line according to expression (166), which will be sloped toward the axis/axle of abscissas at the angle, whose tangent $\text{tg } \alpha = -2\rho_{BC}$. The intersection of these straight lines gives regime point $B_{30}^B(h_{30}^B; \omega_{30}^B)$. By further construction we find all values h^A and h^B interesting to $A_{n^0}^A$, where
$$n = \frac{2(\theta_{AB} + \theta_{BC})}{\theta_{AB}}.$$

For determining the modal point $A_{(n+2)\theta_{AB}}$ we make the following

constructions.

According to equation (175) we carry out the straight line, which leaves from point $B_{(n+1)AB-2\theta_{BC}}$ with the inclination/slope toward the axis/axle of abscissas α_1 ($\text{tg } \alpha_1 = 2\theta_{BC}$). The intersection of this straight line with the axis/axle of abscissas gives regime point $C_{(n+1)AB-\theta_{BC}}$. Regime point $B_{(n+1)AB}$ lies/rests on the intersection of straight lines, given by equations (171) and (172).

We further carry out straight line through point $B_{(n+1)AB}$ at angle β ($\text{tg } \beta = -2\theta_{AB}$) before the intersection with the axis/axle of ordinates. Intersection with this straight line with the axis/axle of ordinates gives regime point $A_{(n+2)AB}$.

All remaining regime points are located by analogous constructions.

Propagation of pressure jump.

Impact pressures in the pressure cylinders or in its conduits/manifolds appear not only during the abrupt deceleration of fluid flow, but also during the discovery/opening of the pressure valve, which combines storage battery/accumulator or conduit/manifold, which is located under the high pressure, with the

conduit/manifold, in which the pressure is equal to the low pressure of filler system.

Thus, for instance, in the working cylinders appears impact pressure during the discovery/opening the pressure valve, when faces or dies/stamps of press are enclosed.

In opposite cylinders the impact pressure appears each time during switching of press from the worker to the back stroke.

In the line from the storage battery/accumulator to the distributing valve device the impact pressure during the discovery/opening of automatic check valve appears.

Page 225.

Let us consider the simplest case of pressure increase at the end of the conduit/manifold, which goes from the storage battery/accumulator, when valve is located near storage battery/accumulator, i.e., on such distance, that the pressure in section/cut B from the side of storage battery/accumulator can be considered constant and equal to H_0 (Fig. 231a). Let us assume that the valve is opened/disclosed instantly (Fig. 231a).

Let us write equation (159) from B_0 to A_{20} , where

$$\theta = \frac{L_{AB}}{a};$$

$$h_0^B - h_{20}^A = -2\mu (u_0^B - u_{20}^A).$$

Since the liquid during the propagation of pressure jump acquires the velocity, equal to $v_{\max} = \frac{H_0 g}{a}$;

$$\mu = \frac{av_0}{2gH_0} = \frac{1}{2}.$$

Substituting

$$u_0^B = 1; \quad u_{20}^A = 0,$$

we will obtain

$$h_{20}^A = 2.$$

Let us further write equation (158) from A_{20} to B_{30} :

$$h_{20}^A - h_{30}^B = 2\mu (u_{20}^A - u_{30}^B),$$

$$h_{30}^B = 1;$$

$$2 - 1 = -2\mu u_{30}^B; \quad u_{30}^B = -1.$$

Let us write equation (159) from B_{20} to A_{30} :

$$h_{20}^B - h_{30}^A = -2\mu (u_{20}^B - u_{30}^A);$$

$$1 - h_{30}^A = -1, \text{ так как } h_{20}^B = u_{20}^B = 1.$$

Key: (1). since.

Whence $h_{30}^A = 2$.

From equation (159), written from B_{30} to A_{40} :

442

$$h_{30}^B - h_{40}^A = -2\mu (u_{30}^B - u_{40}^A), \text{ находим, что } 1 - h_{40}^A = 2\mu, \text{ так как } u_{30}^B =$$

$$= -i \text{ ряд } h_{40}^A = 0.$$

Key: (1). we find that. (2). since.

Thus, in section/cut A in interval $30 > t > 0$ is retained the doubled pressure of storage battery/accumulator. The duplication of pressure can be explained as follows.

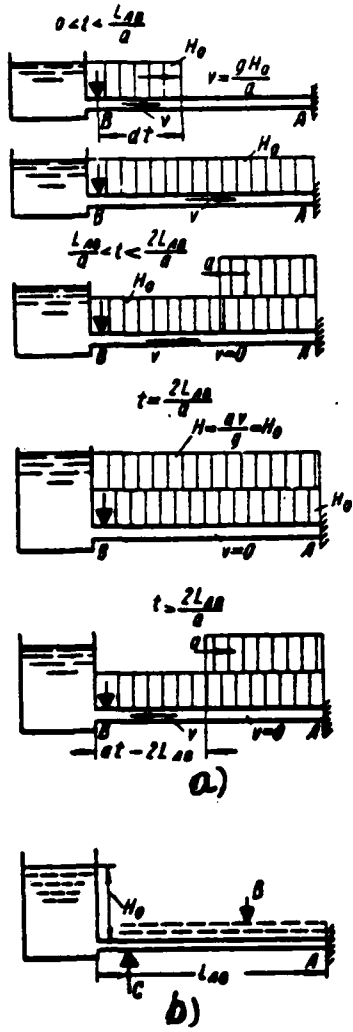

Fig. 231.

Pressure jump H , extends on the conduit/manifold with a velocity of a and simultaneously liquid on that passed by pressure jump section acquires the velocity, equal to $v=gH_0/a$. Up to the moment/torque of time $t=0$ the pressure jump will reach section/cut A and entire liquid column from B to A will prove to be in the motion. At the subsequent moment/torque will be begun the stop of liquid column and the pressure increase along the line from A to B as a result of the hydraulic impact on the same value, i.e., $\frac{av}{g}$.

445

Let us place valve in any place on the line now, for example, so that the distance from A from B would compose half of distance from B to C (Fig. 231b).

Let us designate $\frac{L_{AB}}{a} = \theta$; according to the condition we have $\frac{L_{BC}}{a} = 2\theta$.

Let us write equation (158) from A_0 to $B_{2\theta}$:

$$h_0^A - h_{2\theta}^B = 2\mu (u_0^A - u_{2\theta}^B).$$

At point A the pressure in the range from 0 to θ is equal to zero, and velocity u^A is equal to zero at all values of the time

$$h_{2\theta}^B - 2\mu u_{2\theta}^B = 0.$$

Let us further write equation (159) from C_0 to $B_{2\theta}$:

$$h_0^C - h_{2\theta}^B = -2\mu (u_0^C - u_{2\theta}^B);$$

$$h_0^C = 1; \quad u_0^C = 0; \quad h_{2\theta}^B + 2\mu u_{2\theta}^B = 1.$$

From the obtained equations we find

$$h_{20}^B = \frac{1}{2}.$$

We seek regime point A_{30} :

$$h_{20}^B - h_{30}^A = -2\mu (u_{20}^B - u_{30}^A);$$

$$h_{30}^A = h_{20}^B + 2\mu u_{20}^B = 1.$$

Further

$$h_{30}^A - h_{40}^B = 2\mu (u_{30}^A - u_{40}^B),$$

$$h_{40}^B - 2\mu u_{40}^B = 1;$$

$$h_{20}^C - h_{40}^B = -2\mu (u_{20}^C - u_{40}^B),$$

whence

$$h_{40}^B + 2\mu u_{40}^B = 1.$$

Page 227.

From the obtained equations we have

$$h_{40}^B = 1; \quad u_{40}^B = 0.$$

We seek regime point A_{50} :

$$h_{40}^B - h_{50}^A = -2\mu (u_{40}^B - u_{50}^A),$$

whence

$$h_{50}^A = h_{40}^B = 1.$$

We further write equations for the finding of h_{60}^B :

$$h_{50}^A - h_{60}^B = 2\mu (u_{50}^A - u_{60}^B);$$

$$h_{60}^B - 2\mu u_{60}^B = 1;$$

$$h_{40}^C - h_{60}^B = -2\mu (u_{40}^C - u_{60}^B);$$

$$1 + 2\mu u_{40}^C = h_{60}^B + 2\mu u_{60}^B.$$

For the finding of u_{60}^B let us write equation (158) from B_{30} to C_{40} :

$$h_{20}^B - h_{40}^C = 2\mu (u_{20}^B - u_{40}^C)$$

and, after substituting the known values of values, we will obtain

$$u_{40}^C = 1; \quad h_{60}^B = 1.5; \quad 2\mu u_{60}^B = 0.5.$$

We seek regime point A_{70} :

$$h_{60}^B - h_{70}^A = -2\mu (u_{60}^B - u_{70}^A); \quad h_{70}^B = 2.$$

Thus, pressure at the end of the overlapped conduit/manifold, just as in the case of the installation/setting up of valve in immediate proximity of the storage battery/accumulator, doubles, but with certain retardation.

However, by similar calculations it is possible to show that during the instantaneous valve opening the pressure at the overlapped end of the conduit/manifold doubles in any position of valve on the line (excluding point A).

Impact pressures in an end section/cut of conduit/manifold.

The calculation of impact pressure in the end section/cut of conduit/manifold (Fig. 232) in the hydropress corresponds, for example, to the calculation of impact pressure before the filler valve during its coverage in the transition period from the idling to the worker. In this case it is assumed that the valve is

established/installed directly on the working cylinder or it is close to it.

Page 228.

Since after the valve the section/cut of conduit/manifold sharply varies (diameter of plunger many times of more than the diameter of conduit/manifold), it is possible to disregard a change of the pressure in the cylinder in the valve-closing period and to take it equal to pressure in the period of steady motion.

Let us designate:

$$\rho = \frac{aW_{\max}}{2gl_0F},$$

where W_{\max} - maximum fluid flow rate in the filler conduit/manifold;

F - cross-sectional area of filler conduit/manifold;

a - velocity of propagation of shock waves.

Let us designate:

f - the instantaneous value of the flow passage cross-sectional area of valve;

L - length of filler conduit/manifold;

$\tau = 2L/a$ - phase of conduit/manifold;

w_A - relative fluid flow rate in the section/cut before the valve;

w_B - relative fluid flow rate in the section/cut before the filler tank;

H_0 - pressure in the filler tank;

h_0 - relative pressure in the filler tank (it is accepted as constant and equal to $h_0 = 1$);

h_1^A - relative upstream pressure;

h_u - relative pressure in the working cylinder, equal to pressure with the steady motion;

T - time of closing filler valve;

$$h^A = \kappa (w^A)^2,$$

where is marked $h_1^A - h_u = h^A$;

$$\kappa = \xi \frac{W_{\max}^2}{2gH_0^3},$$

where ξ - the instantaneous value of the drag coefficient of valve.

During the calculation κ (with the known ones of value ξ) a change in the flow passage cross-sectional area of valve can be accepted as linear which is confirmed by experimental data:

$$f = f_0 \left(1 - \frac{t}{T}\right).$$

Let us assume that are known the values κ for any phase of closing valve, i.e., $\kappa_1, \kappa_2, \dots, \kappa_T = 0$.

For the solution of problem we will use equations (160) and (161):

$$h_{i,t}^B - h_t^A = -2\rho (w_{i,t}^B - w_t^A).$$

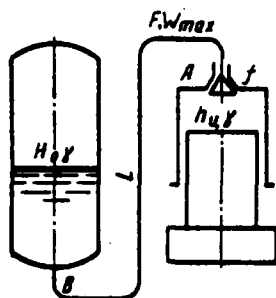

Fig. 232.

Page 229.

In the period from $t=0$ to $t=(\tau/2)=L/a$ the flow rate in section/cut B is equal to initial flow rate, i.e., $w_{\tau/2}^B = 1$.

After substituting in the written equation known values $h_{\tau/2}^B$ and $w_{\tau/2}^B$, we will obtain

$$1 - h_{\tau}^A = -2\rho(1 - w_{\tau}^A).$$

Equation of flow of liquid through the valve

$$h_{\tau}^A = \kappa_{\tau} (w_{\tau}^A)^2.$$

Solving together these equations, let us determine unknowns h_{τ}^A and w_{τ}^A . For subsequent semiphase, the equation will take the form

$$h_{\tau}^A - h_{1/\tau}^B = 2\rho(w_{\tau}^A - w_{1/\tau}^B).$$

From this equation we find

$$w_{1/\tau}^B = \frac{2\rho w_{\tau}^A - h_{\tau}^A + 1}{2\rho}.$$

Knowing $w_{1,2}^B$, we compile an equation for determination of $w_{2\tau}^A$ and

$h_{2\tau}^A$

$$h_{1,2\tau}^B - h_{2\tau}^A = -2\rho (w_{1,2\tau}^B - w_{2\tau}^A);$$

$$h_{2\tau}^A = \kappa_{2\tau} (w_{2\tau}^A)^2.$$

From these equations we find $h_{2\tau}^A$ and $w_{2\tau}^A$.

By the consecutive writing of equations (160) and (161) and the liquid-flow equation through the valve we determine all values h^A and w^A .

However, if a number of phases is great, i.e., is great value $m=T:(2L/a)$, then calculation requires solution m of systems of equations.

Besides this, are not always known the drag coefficients of valve ξ for different periods of its coverage.

For the approximate calculation of impact pressures let us take the dependence linear on the time of fluid flow rate through the valve, i.e., let us assume

$$w^A = w_0^A \left(1 - \frac{t}{T}\right).$$

Then for the first phase of impact/shock we will have

$$1 - h_i^A = -2\rho \left[1 - \left(1 - \frac{\tau}{T}\right)\right];$$

$$h_i^A - 1 = 2\rho \frac{\tau}{T}.$$

Page 230.

Value $h_c^A - 1 = \Delta h_c^A$ is the relative value of impact pressure.

After substituting into this expression ρ and τ , we will obtain

$$\Delta h_c^A = \frac{2Lu_0}{gH_0T}. \quad (178)$$

Since the linear law for the fluid flow rate through the valve was accepted, the obtained relative value of impact pressure will be retained for all subsequent phases to the end of closing valve.

Calculation of impact pressures before the pressure valve of conduit/manifold, feed roller. Coverage of pressure valve.

Calculation is produced for the case, when the plunger of working cylinder is moved with such velocity, that filling of cylinder occurs simultaneously from the storage battery/accumulator and from the filler tank.

In this case the pressure in the cylinder can be accepted by the

equal to zero. Design diagram is shown in Fig. 233.

Pressure in the storage battery/accumulator we will consider constant and equal to H_0 (in the meters).

The velocities of propagation of shock waves in the sections of conduit/manifold AB and CD let us take identical, i.e., $a_{AB} = a_{CD} = a$. Let us designate:

$$\frac{l_{CD}}{l_{AB}} = m; \quad \frac{l_{AB}}{a} = \theta;$$

W and W_{\max} — current and maximum fluid flow rates from the storage battery/accumulator;

$w = \frac{W}{W_{\max}}$ — relative current fluid flow rate on the conduit/manifold;

$$p_{AB} = \frac{aW_{\max}}{2gH_0F_{AB}}; \quad p_{CD} = \frac{aW_{\max}}{2gH_0F_{CD}};$$

h^A, h^B, h^C and h^D — relative pressures in the sections/cuts of conduit/manifold;

$$\kappa_{AB} = \lambda_{AB} \frac{l_{AB}W_{\max}^2}{2gd_{AB}F_{AB}^2H_0};$$

$$\kappa_{CD} = \lambda_{CD} \frac{l_{CD}W_{\max}^2}{2gd_{CD}F_{CD}^2H_0};$$

$$\kappa = \xi \frac{W_{\max}^2}{2gH_0F_{\kappa}^2};$$

where ξ - the instantaneous value of the resistance of valve;

F_x - the instantaneous value of the flow passage cross-sectional area of valve.

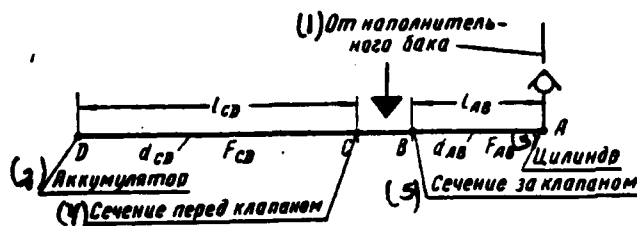

Fig. 233.

Key: (1). From the filler tank. (2). Storage battery/accumulator. (3). Cylinder. (4). Section/cut before the valve. (5). Section/cut after the valve.

Page 231.

With the adopted designations, disregarding velocity and high-altitude heads, let us write the equation of D. Bernoulli for the individual sections of the conduit/manifold:

$$h_0^D - h_0^A = (\kappa_{AB} + \kappa_{CD} + \kappa_0) w_0^2;$$

$$h_0^D - h_0^C = \kappa_{CD} w_0^2;$$

$$h_0^C - h_0^B = \kappa_0 w_0^2;$$

$$h_0^B - h_0^A = \kappa_{AB} w_0^2.$$

For condition $h_0^A = 0$, $h_0^D = 1$, $w_0 = 1$:

$$\kappa_{AB} + \kappa_{CD} + \kappa_0 = 1;$$

$$1 - \kappa_{CD} = h_0^c;$$

$$\kappa_{AB} = h_0^B.$$

With closing of valve the resistance ξ increases, fluid flow rate on the conduit/manifold is reduced, upstream pressure h^c grows, and h^B after the valve drops.

Fluid flow rate on the conduit/manifold varies on the time and at each given moment of time has different value along the length of conduit/manifold.

For simplification in the task upon consideration of losses to the friction we consider that the flow rate during each half-phase of the section of conduit/manifold l_{AB} will be one and the same along the length of conduit/manifold. In this case in the section of conduit/manifold l_{AB} flow rate we will take as the equal to flow rate in section/cut B, and in section l_{CD} — to flow rate in section/cut C.

Page 232.

Let us write equations (160) and (161) for the first half-period θ of conduit/manifold taking into account the pressure, expended during overcoming of fluid friction against the conduit/manifold:

$$h_0^A - h_0^B + \kappa_{AB} (w_0^B)^2 = 2\rho_{AB} (w_0^A - w_0^B);$$

since $h_0^A = 0$, $w_0^A = 1$, then we will obtain

$$h_0^B = \kappa_{AB} (w_0^B)^2 - 2\rho_{AB} (1 - w_0^B); \quad (179)$$

$$h_0^{D'} - h_0^C - \kappa_{CD} (w_0^C)^2 = -2\rho_{CD} (w_0^{D'} - w_0^C);$$

$$L_{CD'} = L_{AB}; \quad h_0^{D'} = 1; \quad w_0^{D'} = 1;$$

$$h_0^C = 1 - \kappa_{CD} (w_0^C)^2 + 2\rho_{CD} (1 - w_0^C). \quad (180)$$

According to the flow-continuity condition

$$w_0^B = w_0^C = w_0. \quad (181)$$

Equation of the escape of the liquid through the valve

$$w_0 = \sqrt{\frac{h_0^C - h_0^B}{\kappa_0}}. \quad (182)$$

Substituting in this equation of value h_0^C and h_0^B , we will obtain

$$w_0 = \sqrt{\frac{1 - \kappa_{CD} w_0^2 + 2\rho_{CD} (1 - w_0) - \kappa_{AB} w_0^2 + 2\rho_{AB} (1 - w_0)}{\kappa_0}}. \quad (183)$$

Let us designate

$$\frac{1}{\kappa_0} = \alpha_0; \quad 2\rho_{AB} + 2\rho_{CD} = \beta; \quad \kappa_{AB} + \kappa_{CD} = \gamma.$$

Solving equation (183), we will obtain

$$w_0 = \sqrt{\left(\frac{1}{2} \cdot \frac{\alpha_0 \beta}{1 + \alpha_0 \gamma}\right)^2 + \frac{\alpha_0 (1 + \beta)}{1 + \alpha_0 \gamma}} - \frac{1}{2} \frac{\alpha_0 \beta}{1 + \alpha_0 \gamma}. \quad (184)$$

Substituting obtained value w_0 into formulas (179) and (180), we find h_0^C and h_0^B .

Value $w^A = 1$ is retained during entire half-period of conduit/manifold l_{AB} , i.e., $w_0^A = 1$.

At all values t , $h^D = 1$, and $w^D = 1$ — with $0 \leq t \leq m\theta$.

Therefore $h_{2\theta}^B$, $h_{2\theta}^C$ and $w_{2\theta}$ will have expressions, analogous to equation (184), with appropriate substitution in them of index θ on 2θ .

Page 233.

We further determine value $w_{2\theta}^A$ from the following equation:

$$\begin{aligned} h_0^B - h_{2\theta}^A - \kappa_{AB} (w_0^B)^2 &= -2\rho_{AB} (w_0^B - w_{2\theta}^A); \\ w_{2\theta}^A &= 2w_0^B - 1. \end{aligned} \quad (185)$$

From the equations, analogous (179) (180) (181) and (182), but those written for the following half-period of conduit/manifold l_{AB} , we find

$$\begin{aligned} h_{3\theta}^B &= \kappa_{AB} (w_{3\theta}^B)^2 + 2\rho_{AB} w_{3\theta}^B - 2\rho_{AB} w_{2\theta}^A; \\ h_{3\theta}^C &= 1 - \kappa_{CD} (w_{3\theta}^C)^2 + 2\rho_{CD} (1 - w_{3\theta}^C); \\ w_{3\theta} &= \sqrt{\left[\frac{1}{2} \cdot \frac{a_{3\theta}^2}{1 + a_{3\theta}} \right]^2 + \frac{a_{3\theta} |1 + 2\rho_{CD} + 2\rho_{AB} (2w_0 - 1)|}{1 + a_{3\theta}}} - \\ &\quad - \frac{1}{2} \cdot \frac{a_{3\theta}^2}{1 + a_{3\theta}}. \end{aligned} \quad (186)$$

Producing analogous calculations, it is possible to determine all values w , h^B , h^C to the moment/torque of time $t=2m\theta$.

From the moment/torque of time $t > m\theta$ value $\omega_i^D \neq 1$ and for determining the values ω , h^B , h^C it is necessary to additionally write equations from h^C and h^D .

For example,

$$\begin{aligned} h_{(m+1)\theta}^D - h_{(2m+1)\theta}^C - \kappa_{CD} (\omega_{(2m+1)\theta}^C)^2 = \\ = -2\rho_{CD} (\omega_{(m+1)\theta}^D - \omega_{(2m+1)\theta}^C). \end{aligned} \quad (187)$$

In this equation

$$\omega_{(2m+1)\theta}^D \neq 1.$$

For determining its value let us write equation from h_i^C to $h_{(m+1)\theta}^D$

$$h_i^C - h_{(m+1)\theta}^D + \kappa_{CD} (\omega_i^C)^2 = 2\rho_{CD} (\omega_i^C - \omega_{(m+1)\theta}^D), \quad (188)$$

whence after the conversions

$$\omega_{(m+1)\theta}^D = 2\omega_i^C - 1.$$

Calculation of the compensators of hydroshock.

For warning/preventing the appearance of large force of hydroshock in the conduits/manifolds the compensators, which absorb energy of the moving/driving liquid column during the coverage of pressure valve, are established/installed.

As such compensators is applied the expanding conduit/manifold (Fig. 234a) or cylinder with the air cushion or the spring (Fig. 234b, c, d).

Page 234.

The calculation of pressure in the compensators, carried out in the form of the expanding conduit/manifold, can be produced for the case of direct impact according to formulas (162)-(177).

The calculation of pressure in the compensators, carried out according to the diagram Fig. 234b-d can be produced approximately, on the basis of the condition of absorbing by them the entire energy of the moving/driving liquid column from the storage battery/accumulator (filler tank) to the compensator.

Let us designate:

d - diameter of conduit/manifold in cm;

l - length of conduit/manifold m;

v - rate of flow of liquid in the conduit/manifold up to the moment/torque of closing valve in m/s.

Then energy of liquid column will be

$$A = \gamma \frac{\pi d^2}{4g} l \frac{v^2}{2} \frac{1}{100} \approx \\ \approx 0,0004 l d^2 v^2 \frac{(l)}{\kappa 2 M}. \quad (190)$$

Key: (1). kg-m.

For the air compensator we accept air compression on the adiabatic curve. Then the work, absorbed by compensator, is written in the form

$$\frac{p_0 q_0}{n-1} \left[1 - \left(\frac{p_1}{p_0} \right)^{\frac{n-1}{n}} \right] = 2,5 p_0 q_0 \left[1 - \left(\frac{p_1}{p_0} \right)^{0,286} \right].$$

where p_0 and q_0 - initial parameters of compensator respectively in kg/cm² and in cm³;

p_1 - final pressure in the compensator in kg/cm².

Equalizing the written expression of energy of liquid column according to equation (190), we will obtain

$$2,5 p_0 q_0 \left[1 - \left(\frac{p_1}{p_0} \right)^{0,286} \right] = 0,0004 l d^2 v^2$$

or after conversion

$$\left(\frac{p_1}{p_0} \right)^{0,286} = 1 - 0,00016 \frac{l d^2 v^2}{p_0 q_0}.$$

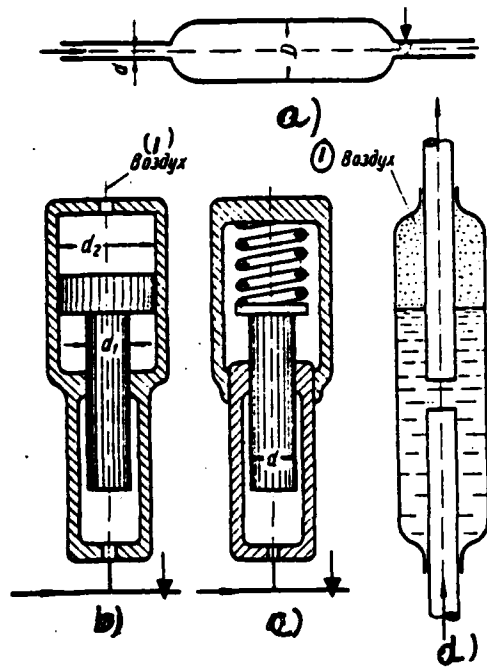

Fig. 234.

Key: (1). Air.

Page 235.

From this expression, being assigned by the initial volume of compensator q , and taking p , as the equal to the pressure of liquid in the storage battery/accumulator (filler tank), we find final pressure in the compensator.

For the compensator, carried out on the diagram Fig. 234b,

$$p_0 = p_a \frac{d_1^2}{d_2^2},$$

where p_a - pressure in the storage battery/accumulator (filler tank);

d_1 and d_2 - respectively the diameters of plunger and piston of compensator.

For the spring compensator the expression for the required work will be written in the form

$$A_1 = \left(N_0 N f + \frac{N^2 f}{2} \right) \cdot 10^{-3} \text{ kg-m}, \quad (191)$$

where N_0 - initial effort/force of spring;

$$N_0 = \frac{\pi d^3}{4} p_a = \frac{S_0}{f},$$

where N - increase in the effort/force of spring;

f - characteristic of spring (its sagging/deflection in mm with the load 1 kg);

S_0 - initial compression of the spring of compensator in mm.

We equate equation (191) with expression (190) for the energy of liquid column:

$$10^{-3} \left(\frac{f}{2} N^2 + f N_0 N \right) = 0,0004 l d^2 v^2;$$

we find

$$f N^2 + 2 f N_0 N - 0,8 l d^2 v^2 = 0;$$

$$N = \frac{-f N_0 + \sqrt{f^2 N_0^2 + 0,8 f l d^2 v^2}}{f}. \quad (192)$$

Piston stroke of the compensator

$$S = f \cdot N.$$

General/common/total effort/force of the spring.

$$N' = N + N_0$$

General/common/total spring sag

$$S' = f(N + N_0).$$

Page 236.

Basic Parameters of Press with a Batteryless Pump Drive.

Velocity of cross-beam.

If the effort/force, which functions on the crosshead, is received in constant, then its velocity can be determined according to the formula

$$v_n = \frac{100W}{6F} \eta_0. \quad (193)$$

where v_n — velocity of the motion of the crosspiece in cm/s;

W — theoretical supply of pump in l/min;

F - total area of plungers in cm²;

η_o - volumetric coefficient of the hydraulic system of press, which considers leaks/leakages and being the function of the pressure of liquid;

$$\eta_o = \eta_{o \min} + (1 - \eta_{o \min}) \frac{p_{\max} - p}{p_{\max}}$$

where $\eta_{o \min}$ corresponds to maximum pressure in the hydraulic system and it is approximately equal to 0.7-0.9.

With an abrupt change of resisting of forging or stamping the delay/retarding/deceleration of the velocity of the motion of cross-beam as a result of the elasticity of the system of press (compression, liquid, the deformation of columns, etc.) occurs.

The elasticity of system during the determination of the velocity of the motion of cross-beam, if a change in the effort/force in the course of cross-beam $P=P(S)$ is known, can be taken into consideration as follows.

Let us designate:

Q_o - volume of liquid in the system of working cylinders;

E_s — modulus of elasticity of liquid;

E_k — modulus of elasticity of the material of columns (struts);

l_k — length of columns (struts);

F_k — total cross-sectional area of columns (struts).

With the pressure increase in the system on Δp the volume of liquid it varies by the value, equal to

$$\Delta Q = \frac{Q_0 \Delta p}{E_s} + \frac{F_p l_k \Delta p}{F_k E_k}$$

The value of volume change corresponds to the course of the cross-beam

$$\Delta S = \frac{\Delta Q}{F_p} = \frac{Q_0 \Delta p}{E_s F_p} + \frac{F_p l_k \Delta p}{F_k E_k}$$

and the velocity

$$v_1 = \frac{\Delta Q}{F_p \Delta t} = \frac{Q_0 \Delta p}{E_s F_p \Delta t} + \frac{F_p \Delta p}{F_k E_k \Delta t}$$

In the limit we will obtain

$$v_1 = \frac{dp}{dt} \left(\frac{Q_0}{E_s F_p} + \frac{F_p l_k}{F_k E_k} \right)$$

Page 237.

Substituting

$$\frac{dp}{dt} = \frac{dp}{dS} \cdot \frac{dS}{dt} = \frac{dp}{dS} v_n,$$

we will obtain

$$v_1 = v_n \frac{dp}{dS} \left(\frac{Q_0}{E_0 F_p} + \frac{F_p \mu \kappa}{F_n E_n} \right).$$

where v_n — velocity of cross-beam.

Let us designate bracketed expression through ϵ , then

$$v_1 = v_n \epsilon \frac{dp}{dS}. \quad (194)$$

Thus, the real velocity of cross-beam will be equal to

$$v_n = \frac{100 \cdot W}{6F} \eta_0 \left(1 - \epsilon \frac{dp}{dS} \right). \quad (195)$$

Driving power.

The pressure of liquid in the pressure cylinders corresponds to the effort/force, which functions on the plunger, and it is equal

$$p = \frac{1000 \cdot P}{F_{plm}}. \quad (196)$$

469

where P - is the force acting on the plunger, in m;

η_m - the mechanical efficiency of the press (it considers losses to friction: plungers in the guide bushing and seals; cross-bars in guides, etc.).

Correspondingly, the pressure developed by the pumps equals

$$p_n = \frac{p}{\eta_h} \quad (197)$$

where η_h - efficiency of the hydraulic system of the press (are considered losses to fluid friction in the conduit/manifold).

The power, developed with press, is equal to

$$N = \frac{pW}{612} \eta_o \eta_m. \quad (198)$$

Respectively shaft horsepower of the pump

$$N_n = \frac{p_n W}{612 \eta_m}. \quad (199)$$

where η_m - mechanical efficiency of pump.

The power applied to the press differs from shaft horsepower of pump N_n to the efficiency of engine η_e :

$$N_n = \frac{N_e}{\eta_e}.$$

Page 238.

Power input, expressed through the effort/force on the plunger and the velocity of plunger,

$$N_n = \frac{Pv_n}{10.2 \eta_m \cdot \eta_o \cdot \eta_e \cdot \eta_m \cdot \eta_o} = \frac{Pv_n}{10.2 \eta}. \quad (200)$$

where η - efficiency of press installation/setting up; its value varies from 0.6 to 0.85.

Effect of the elastic elements of system on the parameters of press at the recurrent course of cross-beam.

If we visualize the system of the drive of the press of absolutely rigid, then in the boost period of its moving elements the pressure in the system must approach infinity. Therefore the moving

elements of the press must instantly gain the velocity, which corresponds to the supply of pump.

In actuality maximum pressure in the boost period is limited by the specific value as a result of the presence in system of the drive of elastic elements/cells (liquid, conduit/manifold, cylinder, etc.), and also as a result of the leaks/leakages from the system and the pliable engine characteristic.

During the dispersal/acceleration in the various periods occurs the accumulation of potential energy by the elastic elements/cells of press, and then the conversion of potential energy into the kinetic. As a result of this occurs fluctuation of the pressure of liquid in the system and with respect to this the fluctuation of way and velocity of moving elements, and also the fluctuation of the required power.

The character of fluctuations depends on the character of forces of friction.

Let us consider the simplest case of moving the plunger, whose cylinder it is fed by the pump of constant supply (Fig. 235).

Let us designate:

w - supply of pump in cm^3/s ;

m - mass of moving elements.

Remaining designations are clear from the diagram Fig. 235.

It is disregarded by forces of friction and by mass of liquid in the system. We designate the vertical displacement of plunger from its position of equilibrium through x and we will consider this displacement positive in the direction upward.

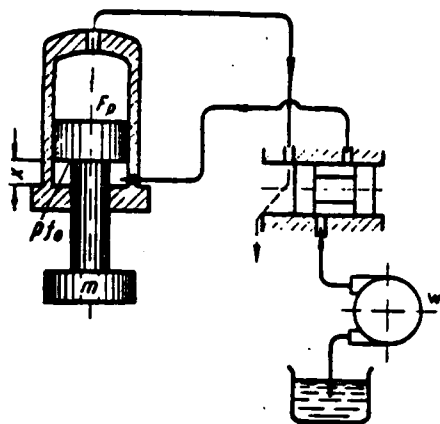

Fig. 235. The design diagram of press.

Page 239.

Let us assume that the press is fed from the multiplunger pump and that the cylinder with the pump is connected by relatively short conduit/manifold. In this case it is possible to consider that the pressure in the system is changed continuously on the time.

We designate through Q the volume of liquid in the system, which corresponds to any position of plunger; then the compression of liquid in the system for time dt will be equally

$$dQ = \left(w - \frac{dx}{dt} f_0 \right) dt. \quad (201)$$

A pressure increment in the cylinder for the same time will comprise

$$dp = E \frac{dQ}{Q}. \quad (202)$$

where E - modulus of elasticity of system liquid - conduit/manifold.

Substituting in equation (202) value of dQ, we will obtain

$$dp = \frac{E}{Q} \left(w - \frac{dx}{dt} f_0 \right) dt. \quad (203)$$

The equation of motion of plunger takes the form

$$m \frac{d^2x}{dt^2} - p f_0 = 0. \quad (204)$$

Differentiating with respect to time equation (204), we will obtain

$$m \frac{d^3x}{dt^3} - \frac{E f_0}{Q} \left(w - \frac{dx}{dt} f_0 \right) = 0. \quad (205)$$

With the displacement of plunger to value x the volume of liquid in the system will be equal to $Q = Q_0 + x f_0$, where Q_0 - initial volume at moment/torque $t=0$.

In the case, when value $x_{max} f_0$ is low in comparison with Q_0 and it can be disregarded/neglected, we will have

$$\frac{d^3x}{dt^3} + \frac{E f_0^2}{m Q_0} \frac{dx}{dt} - \frac{E w f_0}{m Q_0} = 0. \quad (206)$$

The solution of this equation takes the form

$$x = \frac{w}{f_0} t - \frac{w}{f_0^2} \sqrt{\frac{m Q_0}{E}} \sin f_0 \sqrt{\frac{E}{m Q_0}} t; \quad (207)$$

$$\frac{dx}{dt} = v = \frac{w}{f_0} - \frac{w}{f_0} \cos f_0 \sqrt{\frac{E}{m Q_0}} t. \quad (208)$$

Integration constant are found from the initial conditions: $t=0$;
 $x=0$, $\frac{dx}{dt} = 0$ and $\frac{d^2x}{dt^2} = 0$.

Equations (207) and (208) show that the vertical motion of plunger will have an oscillatory nature.

Page 240.

The period of this oscillation and frequency will be equal to

$$T = 2\pi \sqrt{\frac{mQ_0}{E f_0^2}}; \quad (209)$$

$$a = \frac{1}{2\pi} \sqrt{\frac{E f_0^2}{mQ_0}}. \quad (210)$$

The amplitude of oscillations, i.e., the greatest deviation of plunger from the line, which characterizes uniform motion (w), will be equal to

$$A_x = \frac{w}{f_0} \sqrt{\frac{mQ_0}{E}}. \quad (211)$$

Amplitude, speed fluctuations, i.e., its greatest deviation from the velocity of uniform motion (w/f_0), will be equal to

$$A_v = \frac{w}{f_0}. \quad (212)$$

For the establishment of dependence $p=\varphi(t)$ we solve equation (203).

Integrating equation (203), we have

$$p = \frac{E}{Q_0} (\omega t - f_0 x) + C. \quad (213)$$

From the initial conditions: $t=0$, $x=0$, $p=0$ and $C=0$

$$p = \frac{E}{Q_0} (\omega t - f_0 x). \quad (214)$$

Substituting in this equation value of x , we will obtain the equation, which expresses the dependence of pressure on the time:

$$p = \frac{\omega}{f_0} \sqrt{\frac{Em}{Q_0}} \sin \sqrt{\frac{Ef_0^2}{mQ_0}} t. \quad (215)$$

In the given problem the force of friction was not considered.

The character of fluctuation of pressure in the system, and also the way and the velocity of plunger they depend on the character of a change in forces of friction.

Effect of the varied conditions for friction on fluctuation of pressure in the system represented graphically in Fig. 236.

The experimental study of press by the effort/force 3000 t, given from rotary pumps, showed that in the recurrent pressure cylinders during the motion of cross-beam upward appear fluctuations of oil pressure (Fig. 237) with the amplitude, somewhat less in

AD-A139 822

HYDRAULIC PRESSES(U) FOREIGN TECHNOLOGY DIV
WRIGHT-PATTERSON AFB OH B V ROZANDY 09 MAR 84
FTD-ID(R5)T-1207-83

6/10

UNCLASSIFIED

F/G 13/9

NL

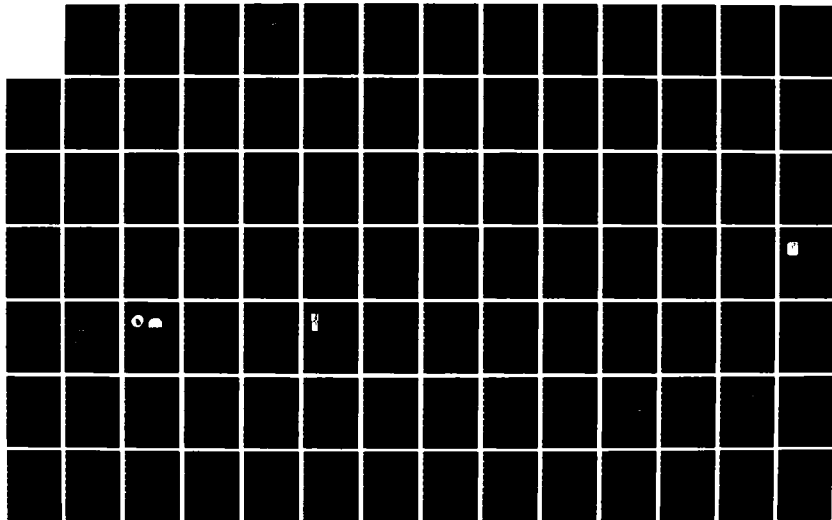

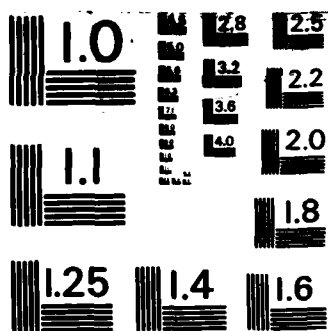

MICROCOPY RESOLUTION TEST CHART
NATIONAL BUREAU OF STANDARDS-1963-A

comparison with the calculated [5].

According to the character of the attenuation of the amplitude of oscillation (to damping decrement) it is possible to also establish that the forces of friction, led to the plunger, are proportional to the velocity its motion in the degree, close to one.

On the character of fluctuation of pressure in the system affect such factors, as the value of the leaks/leakages of liquid from the system, the pliability/compliance of the characteristic of the electric motor, which revolves pump; the character of a change in the load, which functions on the plunger, and other factors, omitted when deriving the equations.

The large leaks/leakages of liquid from the system and the pliable characteristic of electric motor lead to decrease and damping of oscillations/vibrations and even to their complete destruction. A change in the load on the plunger, on the contrary, increases fluctuation of pressure in the system.

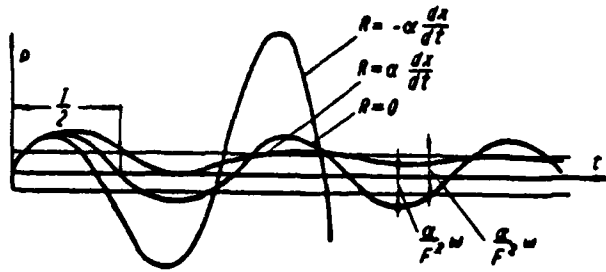

Fig. 236. Effect of the varied conditions for friction on fluctuation of pressure in the hydraulic system of press.

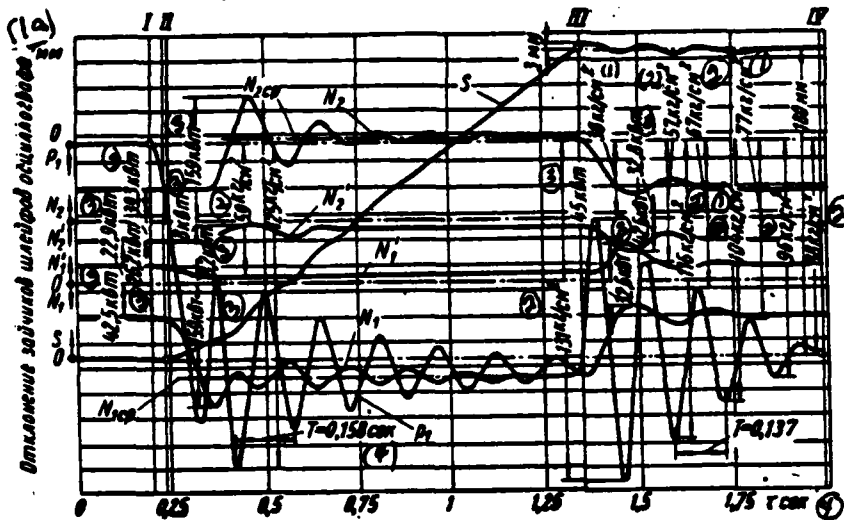

Fig. 237. Experimental curves, which characterize the work of press by effort/force 3000 t. On the graph the characteristic moments/torques of the work of the press are noted: I - beginning of the lift of pressure in the pull-backs; II - the start of slider upward; III - stop of slider in the end upper position; IV - termination of fluctuations of pressure in the pull-backs; S - piston stroke; p_1 - pressure in the pull-backs; N_1 and N_2 — active powers of engines; N'_1 and N'_2 - the reactive power of engines.

Key: (1). kg/cm^2 . (1a). Deviation of the light spots of the trails of oscillograph. (2). kg/cm^2 . (3). kW. (4). s.

Page 242.

In the given research is examined the motion of plunger upward, i.e., with the recurrent stroke of press. With the working stroke of fluctuations of pressure virtually is not observed, since into the expression of the amplitude of oscillations $A_x = \frac{w}{F_p^2} \sqrt{\frac{mQ_0}{E}}$ into the denominator enters the area of plunger squared F_p^2 , a value many times larger with the working stroke in comparison with recurrent by course.

During the selection of the sizes/dimensions of the cylinders of recurrent course, and also during the design of the hydraulic system of press it is necessary to consider the possibility of a sharp pressure increase in the hydraulic system in the boost period of moving elements.

Is recommended design pressure in the cylinders accepting a little larger pressure with the steady motion of plunger, and on the line of reverse/inverse cylinders the establishing/installing of the valve, which limits pressure. In this case the value of the flow passage cross-sectional area of valve must approach a value of the clear area of the duct/tube/pipe, which goes to the reverse/inverse cylinders.

Basic Parameters of Press with the Pump-and-battery Drive.

Nominal effort/force of press, its power and efficiency.

According to the equation of D. Bernoulli (115), when in system the storage battery/accumulator of high-pressure liquid is present, which feeds working pressure cylinders during the working stroke, the free-running speed of the plunger (cross-beam) of press depends on pressure difference in the storage battery/accumulator and in the cylinder. Thus, on the known from the working graph effort/force on the cross-beam and the pressure in the cylinder it is possible to determine an optimum pressure differential between the storage battery/accumulator and the working cylinder in the cycle of motion of plunger.

The optimum pressure differential indicated M. V. Storozhev [3] proposed to determine from the condition of obtaining the maximum power, developed with press.

This power during the pump-and-battery drive of press at the constant value of the drag coefficients of hydraulic system depends on the ratio of pressure in the working cylinder to the pressure in the storage battery/accumulator or, in other words, from the relation of effort/force, developed with press, to his nominal effort/force,

equal to $\rho_e F$.

The power, developed with press, is equal to

$$N = P \cdot v = \rho F \varphi \sqrt{2g(\rho_e - \rho)} = \kappa \cdot \rho \sqrt{\rho_e - \rho}. \quad (216)$$

where φ - given drag coefficient on the line from the storage battery to the working cylinders, multiplied by $\sqrt{10}$;

ρ_e - pressure in the storage battery/accumulator in kg/cm^2 .

Page 243.

Differentiating of expression for N and equalizing it with zero, we will obtain

$$N' = (\kappa \sqrt{\rho_e \cdot \rho^3 - \rho^4})' = \frac{\kappa}{2} \cdot \frac{2\rho_e \cdot \rho - 3\rho^3}{\sqrt{\rho_e \cdot \rho^3 - \rho^4}} = 0. \quad (217)$$

From this expression it follows that the maximum power coefficient N_{\max} corresponds

$$\rho = \frac{2}{3} \rho_e. \quad (218)$$

Thus, if the press is designed for the technological operations, with which the effort/force on the cross-beam remains constant for the elongation/extent of entire working course, then so that it would work with the maximum power, its nominal effort/force must be one and a half times of more than required effort/force for the realization of technological operation.

When the effort/force, which functions on the cross-beam, is changed on its course, the ratio of the nominal effort/force of press to the effort/force on the cross-beam can be found from the maximum average/mean power of press in the period of working stroke, i.e., from the maximum value

$$\left(\frac{PS}{t}\right)_{\max}$$

where S - value of complete working course;

t - time of working stroke.

Let us determine relationships/ratios $\frac{P_{\max}}{P_0}$ for the graph of loads on the cross-beam, which is trapezoid (Fig. 238).

By trapezoidal graph for the approximate computations can be substituted the majority of real graphs.

Let us designate:

p₀ - pressure in the working cylinder at the beginning of working stroke;

$p_0 + \alpha S = p_0 + m$ - required maximum pressure in the working cylinders at the end of the working stroke;

α - see Fig. 238;

$$\sqrt{p_0 - p_0} = \beta.$$

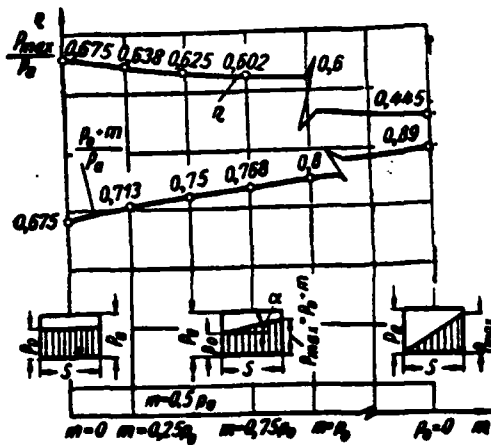

Fig. 238. Dependence of the ratio of maximum required effort/force for the deformation to the nominal effort/force of press from the condition of the maximum value of the average/mean power of press for the period of working stroke and the corresponding values efficiency (without taking into account losses to the deformation of liquid).

Page 244.

The velocity of the motion of cross-beam is equal to

$$\frac{ds}{dt} = \sqrt{p_a - p_0 - aS}. \quad (219)$$

The constant coefficient before the root is rejected/thrown, since it does not affect the result of calculation.

After leading integration, we will obtain

$$\sqrt{p_a - p_0 - aS} = -\frac{at}{2} + C. \quad (220)$$

The arbitrary constant C we find from the initial conditions:
with $t=0$ $S=0$.

Consequently,

$$C = \sqrt{\rho_a - \rho_0} = \beta,$$

whence

$$t = \frac{2\beta - 2\sqrt{\beta^2 - \alpha S}}{\alpha}. \quad (221)$$

After raising left and the right side of equation (220) into the square, let us find

$$\alpha S = -\frac{\alpha^2 t^2}{4} + \alpha \beta t.$$

Let us write expression for the power

$$\begin{aligned} N &= p \cdot vF = (\rho_0 + \alpha S) \sqrt{\rho_a - \rho_0 - \alpha S} F = \\ &= \left(\frac{\alpha^2 t^2}{4} - \alpha \beta t + \rho_0 \right) \left(\frac{\alpha t}{2} - \beta \right) F. \end{aligned} \quad (222)$$

Then work for the time of working stroke is expressed in the form

$$A = \int_0^t N dt = \left(\frac{\alpha^3 t^4}{32} - \frac{\alpha^2 \beta t^3}{4} + \frac{\alpha \beta^2 t^2}{2} - \frac{\alpha \rho_0 t^2}{4} + \beta \rho_0 t \right) F. \quad (223)$$

Average/mean power for the same time is equal to

$$N_{cp} = \frac{A}{t} = \left(\frac{\alpha^3 t^3}{32} - \frac{\alpha^2 \beta t^2}{4} + \frac{\alpha \beta^2 t}{2} - \frac{\alpha \rho_0 t}{4} + \beta \rho_0 \right) F. \quad (224)$$

Equalizing derivative $\frac{dN_{cp}}{dt} = 0$, we find the value, which corresponds to maximum value N_{cp} :

$$t = \frac{8\beta - \sqrt{16\beta^2 + 24\rho_0}}{3\alpha}. \quad (225)$$

From the comparison of equations (221) and (222) and

substituting $\beta = \sqrt{\rho_a - \rho_0}$ we find

$$\alpha S = m = \frac{4\rho_a - 10\rho_0 + \sqrt{\rho_a - \rho_0} \sqrt{16\rho_a + 8\rho_0}}{9} \quad (226)$$

Page 255.

From the obtained expression we find values $\frac{\rho_0 + m}{\rho_a}$ (Fig. 238).

From the graph Fig. 238 it follows that the more slowly increases the resistance to deformation or, in other words, pressure in the working cylinders and the less this pressure in the beginning of working stroke, the less must be the pressure differential between the storage battery/accumulator and the working cylinders. The efficiency of drive in any moment of the working stroke of press is equal to the ratio of pressure in the cylinder to the pressure in the storage battery/accumulator, and thus the "denser" the graph of working resistance or, in other words, the less the drop/jump between the pressure in the storage battery/accumulator and the pressure and cylinder, the higher the efficiency of drive.

The dependence of the velocity of the motion of cross-beam and efficiency of drive on $\frac{\rho}{\rho_a}$ is given in Fig. 239.

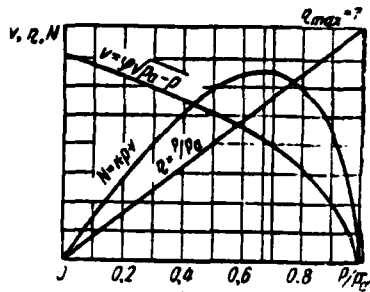

Fig. 239. Graph/diagrams of the dependence of the velocity of the motion of the transfer plunger v , power N , developed with press, and its efficiency (η) (without taking into account losses to the deformation of liquid) on the ratio of pressure in the working cylinder (p) to the pressure in storage battery/accumulator (p_a).

Stepped drive of press.

For increasing the efficiency/cost-effectiveness of the operation of press in such a case, when it works with the variable/alternating/variable force on the cross-beam, its systems of drive and control it must allow/assume work with different steps/stages of the nominal effort/force, developed with press. The steps/stages of efforts/forces can be accomplished/realized either by a consecutive connection, with an increase of resistance on the cross-beam, different number of working cylinders or by a consecutive stepped pressure increase of the liquid, supplied to the press with multiplier. The same effect can be obtained with the feeding from

several storage batteries with the different pressures of liquid.

Let the graph of resistance during the deformation of blank on the press take the form, shown in Fig. 240. The curve AB expresses dependence $P=P(S)$, where P - resisting force of blank; S - working stroke of the cross-beam of press.

The useful work A_1 , accomplished by press, is expressed by area OABC. In such a case, when press works with one step/stage on the effort/force (Fig. 240a), then the work, accomplished by press for working stroke S_p (if we place pressure in the storage battery/accumulator by constant), will comprise

$$A_2 = P_n \cdot S_p,$$

where P_n - nominal effort/force, developed with press. This work is represented on the graph with the area of rectangle ODEC. Then the work, lost on friction, comprises

$$A_m = A_2 - A_1.$$

Page 246.

Graph of Fig. 240a shows this work by shaded area. the efficiency of press with the working stroke, which considers energy loss to fluid friction in the conduit/manifold, only will be equal to the relation

$$\eta_r = \frac{A_1}{A_2}.$$

With the work of press with several steps/stages of efforts/forces, for example, with three (Fig. 240b), consumed work will be represented by area ODEFGHEC, and the economy of high-pressure liquid, i.e., the economy of energy consumption, by area KHGFEDK it will be equal to

$$(P_n - P_1)S_1 + (P_n - P_2)S_2.$$

It is obvious that the more the steps/stages of efforts/forces it has a press, the higher its efficiency.

With the selected number of steps/stages of efforts/forces the numerical value of each step/stage must be selected so that the relation

$$\frac{P_1S_1 + P_2S_2 + \dots + P_nS_n}{A_1}$$

would be minimum.

Relations $\frac{P_1}{P_1}, \frac{P_2}{P_2}, \frac{P_n}{P_D}$ must satisfy the condition of obtaining the maximum averaged power of press in each section of working stroke.

The average speeds of the motion of cross-beam in the individual sections of working stroke must be selected from the condition of obtaining the preset time of the working stroke T:

$$T = \frac{S_1}{v_1} + \frac{S_2}{v_2} + \dots + \frac{S_n}{v_n}.$$

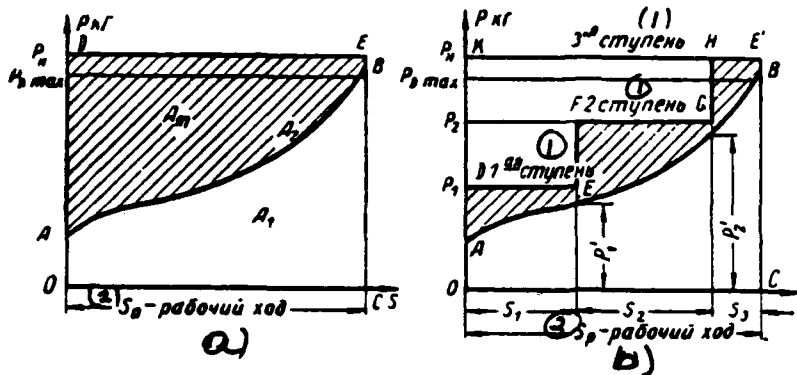

Fig. 240. Graphs, which illustrate the economy of energy with the work of press with several steps/stages of the efforts/forces: a) the graph of the work of press with one step/stage of efforts/forces; b) the graph of the work of press with three steps/stages of efforts/forces.

Key: (1). step/stage. (2). working stroke.

Page 247.

Ways and the velocity of the motion of the cross-beam of press.

General/common/total equations.

Let us consider the overall diagram of the hydraulic press, given from pump-and-battery station (Fig. 241).

Let us take the same designations, that also is earlier, and additionally let us designate:

p_n - overpressure in the filler tank in kg/cm^2 ;

γ - specific gravity/weight of working fluid in g/cm^3 ;

G - weight of the moving elements of the press in kg ;

P - effort/force, that function on the plunger, in kg ;

R - sum of forces of friction (in the sealings/packings/compactions, in the guides of the crosshead), which

resist to motion of cross-beam.

Subsequently diameters and the areas of plungers we will note by the indices: r - working plungers; C - recurrent plungers; u - balancing plungers.

With the work of press, pressure in the storage battery/accumulator and the filler tank do not remain constant. An attempt at the solution of problem taking into account variability p_a and p_n meets serious ones - mathematical difficulties.

9 Subsequently we take p_a and p_n as constants and equal to their minimum values. Is disregarded high-altitude pressures in comparison with the pressure in the storage battery/accumulator on the smallness.

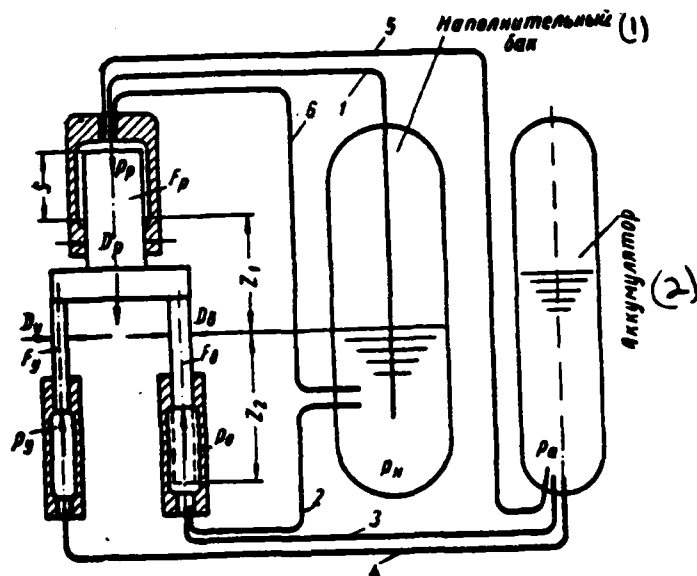

Fig. 241. The design diagram of press with the pump-and-battery drive: 1 - forcing line with the idling; 2 - drain line of pull-backs; 3 - forcing line of pull-backs; 4 - forcing (drain) line of the balancing cylinders; 5 - forcing line of working cylinders; 6 - drain line of working cylinders.

Key: (1). Filler tank. (2). Storage battery/accumulator.

Page 248.

In other cases we take their extreme values, with which the velocities of cross-beam will have the smaller values. Resistance in sealings/packings/compactions of cylinders approximately can be determined from the relationship/ratio

$$R_y = \kappa \frac{P}{D},$$

where κ - factor of the proportionality (see Chapter 3).

Resistance in the guides of cross-beam in the period of the filling of working cylinders and return to the initial position can be tentatively accepted by equal to $R_n \approx 0,02G$.

For the working stroke by resistance R on the smallness it is possible to disregard.

With the adopted designations the equation of motion of the cross-beam of press in general form will be written in the following form:

$$-10^{-3} \frac{G}{g} \cdot \frac{dv}{dt} \pm F_p \rho_p \mp F_s \rho_s \mp F_y \rho_y - p - R \pm G = 0. \quad (227)$$

Pressures in cylinders p_p, p_s, p_y , entering this equation, can be obtained from the solution of the equation of the unsteady one-dimensional motion of incompressible fluid (129), conduit/manifold comprised for the appropriate lines.

Substitution in equation (227) of values p_p, p_s, p_y , reduces it to the form of equation (132):

$$a \frac{dv}{dt} + bv^2 - c = 0. \quad (228)$$

In this equation term c can be both variable and constant quantity, depending on of that, the motion what mechanism and in what period is examined.

With $c=\text{const}$ this equation will be actually/really (Fig. 241) for the idle and recurrent strokes of cross-beam, and also for the working stroke when the effort/force, which functions on the cross-beam, remains constant for the elongation/extent of entire working course.

Let us find the value of the way of cross-beam in the function of time, after integrating expression vdt :

$$S = \int vdt = \frac{a}{2b} \ln \frac{\left(e^{\frac{2}{a} \sqrt{cb}t} + 1 \right)^2}{4e^{\frac{2}{a} \sqrt{cb}t}} + C. \quad (229)$$

Arbitrary integration constant is equal to $C=0$ from the initial conditions: $t=0$; $S=0$.

For the practical calculations to more conveniently have an expression of the velocity in the function of way, i.e., $v=v(S)$, and the expression of way in the velocity function, i.e., $S=S(v)$, and to also have an expression for determining the running time of cross-beam from the prescribed/assigned path.

The functions indicated take the form

$$v = \sqrt{\frac{c}{b} \left(1 - e^{-\frac{2bS}{a}}\right)}; \quad (230)$$

$$S = \frac{a}{2b} \ln \frac{\frac{c}{b}}{\frac{c}{b} - v^2}; \quad (231)$$

$$t = \frac{1}{2\sqrt{cb}} \ln \left[2e^{\frac{2bS}{a}} \left(1 + \sqrt{1 - \frac{1}{e^{\frac{2bS}{a}}}}\right) - 1 \right]. \quad (232)$$

Idling of cross-beam.

Let us write expressions for the pressures in the pressure cylinders for the boost period, accepting the lengths of conduit/manifold (L) in the meters, and diameters (d) - in the centimeters.

Working cylinder - line 1 (Fig. 241):

$$\begin{aligned} \dot{p}_p = p_n - \gamma \left[Z_1 \cdot 10^{-1} + \frac{D_p^4}{2g} \sum_{i=1}^{i=n_1} \left(\frac{10^{-6}}{d_i^4} + \lambda \frac{10^{-6} L_i}{d_i^5} \right) v^3 + \right. \\ \left. + \frac{10^{-6} D_p^2}{g} \sum_{i=1}^{i=n_1} \frac{L_i}{d_i^2} \frac{dv}{dt} \right]. \end{aligned} \quad (233)$$

u

Pull-backs - line 2.

$$\begin{aligned} \dot{p}_s = p_n + \gamma \left[Z_2 \cdot 10^{-1} + \frac{D_s^4}{2g} \sum_{i=1}^{i=n_2} \left(\frac{10^{-6}}{d_i^4} + \lambda \frac{10^{-6} L_i}{d_i^5} \right) v^3 + \right. \\ \left. + \frac{10^{-6} D_s^2}{g} \sum_{i=1}^{i=n_2} \frac{L_i}{d_i^2} \frac{dv}{dt} \right]. \end{aligned} \quad (234)$$

$$p_y = p_a + \gamma \left[\frac{D_v^4}{2g} \sum_{i=1}^{i=n_2} \left(\frac{10^{-3}}{d_i^4} + \lambda \frac{10^{-3} L_i}{d_i^6} \right) v^2 + \frac{10^{-3} D_v^2}{g} \sum_{i=1}^{i=n_2} \frac{L_i}{d_i^2} \cdot \frac{dv}{dt} \right]. \quad (235)$$

Balancing cylinders - line 4:

Page 250. Effort/force on crosshead during the idling is absent, i.e., $P=0$.

After substituting the written expressions in equation (227), after matching the dimensionality of values and converting it to the form of equation (228), we will obtain the following values of the constants of this equation:

$$a = \frac{1}{g} \left[10G + D_p^2 F_p \sum_{i=1}^{i=n_1} \frac{L_i}{d_i^2} + D_s^2 F_s \sum_{i=1}^{i=n_2} \frac{L_i}{d_i^2} + D_v^2 F_v \sum_{i=1}^{i=n_3} \frac{L_i}{d_i^2} \right]; \quad (236)$$

$$b = \frac{1}{2g} \left[F_p D_p^4 \sum_{i=1}^{i=n_1} \left(\frac{10^{-3}}{d_i^4} + \lambda \frac{L_i}{d_i^6} \right) + F_s D_s^4 \sum_{i=1}^{i=n_2} \left(\frac{10^{-3}}{d_i^4} + \lambda \frac{L_i}{d_i^6} \right) + F_v D_v^4 \sum_{i=1}^{i=n_3} \left(\frac{10^{-3}}{d_i^4} + \lambda \frac{L_i}{d_i^6} \right) \right]; \quad (237)$$

$$c = 10^3 \left[(\rho_n - 10^{-1} Z_1) \left(1 - \frac{\kappa}{D_p} \right) F_p - (\rho_n + 10^{-1} Z_2) \left(1 + \frac{\kappa}{D_s} \right) F_s - \rho_a F_v \left(1 + \frac{1}{D_v} \right) + 0,98G \right]. \quad (238)$$

In the idle period the pressure in the working cylinders must not fall lower than zero so that would not occur the breakage of jet in the filler line:

$$p_p > 0. \quad (239)$$

For explaining the continuity condition let us solve equation (233) relative to v .

Let us designate:

$$\frac{D_p^4}{10^3 2g} \sum_{i=1}^{i=n_1} \left(\frac{10^{-3}}{d_i^4} + \lambda \frac{L_i}{d_i^5} \right) = \beta;$$

$$\frac{D_p^2}{10^3 2g} \sum_{i=1}^{i=n_1} \frac{L_i}{d_i^2} = \alpha;$$

$$p_n - 10^{-1} Z_1 = p_n.$$

With the adopted designations equation (239) will be written in the form

$$p_p > p_n - \beta v^2 - \alpha \frac{dv}{dt} > 0. \quad (240)$$

Page 251.

After substituting into the obtained expression value of dv/dt from equation (228), we will obtain

$$p_p > p_n - \alpha \frac{c}{a} - \left(\beta - \alpha \frac{b}{a} \right) v^2 > 0,$$

whence

$$p_n > \alpha \frac{c}{a} + \left(\beta - \alpha \frac{b}{a} \right) v^2. \quad (241)$$

Equation (241) must be solved for two cases: $v=0$ - the start

$$p_n > \alpha \frac{c}{a}; \quad (242)$$

$v = \sqrt{\frac{c}{b}}$ - steady motion.

$$p_n > \beta \frac{c}{b}. \quad (243)$$

If these conditions are not observed, then this indicates a pressure drop in the cylinder lower than zero and, as a consequence of this, on the breakage of jet in the filler conduit/manifold.

To prevent the breakage of jet is possible by one of the following means:

- 1) by an increase in the diameters of the balancing cylinders;
- 2) by setting intermediate filler tank near the press or by

approximation/approach to a press of basic filler tank;

- 3) the pressure increase in the filler tank;
- 4) by an increase in the section/cut of filler conduit/manifold;
- 5) by the installation/setting up of support valve on the line of pull-backs.

The first of the means indicated is usually most efficient.

Working stroke of cross-beam.

$$P = P(S).$$

For calculating the parameters of the motion of the crosshead in the period of extrusion/pressing it is necessary to know the graph of the effort/force surmounted by cross-beam:

Virtually in all cases the curve $P=P(S)$ by a sufficient for the calculations precision/accuracy it is possible to replace with broken line (Fig. 242) and to perform calculations according to the sections. Then expression for the effort/force, which functions on the cross-beam, for the separate k section of graph is written in the form

$$p_k = m_k + a_k S + R_k.$$

Values m_k and α_k are determined from the graph;

S - the instantaneous value of the course of cross-beam on k section.

Page 252.

Inertia head, expended to the dispersal/acceleration of the liquid, which enters the cylinder as a result of the elasticity of system, is disregarded.

The differential equation of motion of cross-beam for the individual section will take the form

$$a \frac{dv}{dt} + bv^2 = c - \alpha'_k S, \quad (244)$$

where

$$a = \frac{1}{g} \left[10G + D_p^2 F_p \sum_{i=1}^{i=n_p} \frac{L_i'}{d_i^2} + D_o^2 F_o \sum_{i=1}^{i=n_o} \frac{L_i'}{d_i^2} + D_y^2 F_y \sum_{i=1}^{i=n_y} \frac{L_i'}{d_i^2} \right]; \quad (245)$$

$$b = \frac{1}{2g} \left[F_p \left\{ D_p^4 \sum_{i=1}^{i=n_p} \left(\frac{10^{-3}}{d_i^4} + \lambda \frac{L_i}{d_i^5} \right) (1 + \alpha_{k,p})^2 \right\} + \right. \\ \left. + F_o D_o^4 \sum_{i=1}^{n_o} \left(\frac{10^{-3}}{d_i^4} + \lambda \frac{L_i}{d_i^5} \right) + F_y D_y^4 \sum_{i=1}^{n_y} \left(\frac{10^{-3}}{d_i^4} + \lambda \frac{L_i}{d_i^5} \right) \right]; \quad (246)$$

$$c = 10^3 \left[p_o F_p \left(1 - \frac{\kappa}{D_p} \right) - (p_n + 10^{-1} Z_2) F_o \left(1 + \frac{\kappa}{D_o} \right) - \right. \\ \left. - p_o F_y \left(1 + \frac{\kappa}{D_y} \right) + G - R_k - m_k \right]. \quad (247)$$

In expression (246) the value of ϵ is the same as in equation (194):

$$\alpha'_\epsilon = 10^3 \alpha_\epsilon.$$

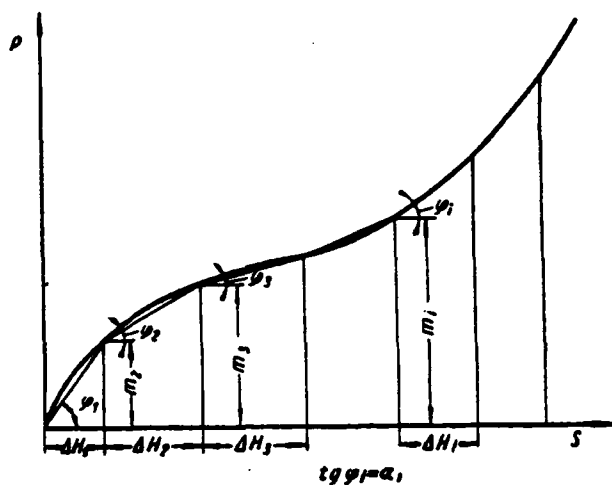

Fig. 242. Exemplary/approximate graph of the loads of press at the working stroke.

Page 253.

Let us write equation (244) in the following form:

$$av \frac{dv}{dS} + bv^2 = c - a_1' S.$$

Applying the substitution

$$u = v^2; \frac{du}{dS} = 2v \frac{dv}{dS}; \frac{du}{dS} + \frac{2b}{a} u = \frac{c - a_1' S}{a} \cdot 2.$$

we will obtain the linear equation, solution of which it will be

$$u = v^2 = e^{-\int \frac{2b}{a} dS} \left[\int 2 \frac{(c - a_1' S)}{a} \cdot e^{\int \frac{2b}{a} dS} dS + A \right].$$

After integration and conversions of this equation we obtain

$$v^2 = Ae^{-\frac{2b}{a} S} + \frac{c}{b} + \frac{a_1' a}{2b^2} - \frac{a_1' S}{b}. \tag{248}$$

Arbitrary integration constant A we find from the initial

conditions: with $S=0$; $v=0$;

$$A = -\left(\frac{c}{b} + \frac{a'x^2}{2b^2}\right).$$

Finally the velocity of cross-beam on the k section will be equal to

$$v_k = \sqrt{\left[v_{k-1}^2 - \left(\frac{c}{b} + \frac{a'x^2}{2b^2}\right)\right] e^{\frac{-2bS}{a}} + \frac{c}{b} + \frac{a'x^2}{b}} S, \quad (249)$$

where k - ordinal number of section on the graph of efforts/forces;

v_{k-1} - velocity of the crosshead at the end of k section;

S - stroke of cross-beam from the beginning of this section.

For determining the time of the motion of the crosshead along the prescribed/assigned path $v_k = \frac{ds}{dt}$ one should in equation (242) replace and solve this equation relative to t . However, substitution in equation (249) $v_k = \frac{ds}{dt}$ leads to the integral, which cannot be solved with the help of the elementary functions, and therefore the determination of the time of the motion of cross-beam during the extrusion/pressing can be produced by the finite-difference method

$$v_k = \frac{ds}{dt} \approx \frac{\Delta S}{\Delta t},$$

whence $\Delta t = \frac{\Delta S}{v_k}$.

Being assigned by different values ΔS , we consecutively/serially determine Δt and complete running time $t = \Sigma \Delta t$.

Page 254.

When the graph of the efforts/forces, which function on the cross-beam, is not prescribed/assigned or it is possible to be bounded to approximate value of velocity and running time in the period of extrusion/pressing, calculation can be produced, accepting for the period of extrusion/pressing the effort/force, which functions on the cross-beam, by constant and equal to ψP , where P - nominal effort/force, developed with press; ψ - coefficient, which considers the character of the loading of press.

In this case in the expressions for coefficient of b and velocity of cross-beam a , should be assumed/set equal to zero.

In the first approximation, the calculation of the velocity of the working stroke of cross-beam can be produced only on the steady motion without taking into account losses of head in the lines from the recurrent and balancing cylinders. In this case the coefficients in equation (242) will have values:

$$a = 0;$$

$$b = \frac{1}{2g} (1 + \epsilon a_x) F_p D_p^4 \sum_{i=1}^{i=n} \left(\frac{10^{-8}}{d_i^4} + \lambda \frac{L_i}{d_i^5} \right).$$

We find value c through equation (247).

Motion of cross-beam with the return to the initial position (recurrent course).

With backward motion of cross-beam the liquid from the working cylinders is abstracted/removed along two lines: through the drain valve of the distributing valve block and through the filler valve (lines 6 and 1 in Fig. 241).

The equation of motion of cross-beam, comprised for the case of the drain of water of the working cylinders along two lines, proves to be too bulky. At the same time bleeding through the distributing valve block can be disregarded/neglected, without making in this case large error in calculation.

An error in the calculation approximately can be established/installed as follows.

For the majority of presses can be accepted the following approximate relationships/ratios:

$$\frac{d_1}{d_0} \approx 2,5; \frac{L_0}{L_1} \approx 2.$$

The ratio of the flow rate of the water, which goes through the distributing valve block, to the general/common/total flow rate can

be determined as follows:

$$\frac{Q_0}{Q_1} = \frac{1}{1 + \left(\frac{d_1}{d_0}\right)^2 \left(\frac{L_0}{L_1}\right)^2} = \frac{1}{1 + 2,5^2 \cdot 2^2} = 0,067.$$

Page 255.

Thus, amount of liquid, passing through the drain valve of the distributing valve block during the recurrent course of cross-beam, comprises less than 7% of the general/common/total jettisoning of liquid from the working cylinders. Further, after producing analogous calculations, that also during the calculation of the motion of cross-beam in the period of the filling of working cylinders, we will obtain the appropriate values of constants in equation (228), written for backward motion of cross-beam.

Increase decompression in working pressure cylinders.

For the creation of the pressure of water in the working cylinders with the working stroke is expended the relatively long time, which should be considered during timing of one cycle of the work of press.

The amount of liquid, which must be fed to the pressure cylinders in order to raise in them pressure on dp it can be written in the form

$$dQ = Q_0 \left(\frac{1}{E_0} + \epsilon' \right) dp, \quad (250).$$

where E_s — modulus of elasticity of liquid in kg/cm²;

ϵ' — coefficient, which considers elastic deformation of the system of press;

Q_0 — volume of liquid in the cylinders toward the end of the working stroke in cm³.

For the corner post-type press, without taking into account the deformation of cylinders, and cross-beams, the value ϵ' composes

$$\epsilon' = \frac{l_c F_p^2}{E F_c Q_0},$$

where l_c — the working length of columns in cm;

E — modulus of elasticity of steel in kg/cm²;

F_c — total cross-sectional area of columns in cm².

Disregarding the amount of liquid, which enters cylinder for the time of the discovery/opening pressure valve, and also without taking into account the acceleration of flow, it is possible to write

$$\frac{dQ}{dt} = v_1 F_p = Q_0 \left(\frac{1}{E_s} + \epsilon' \right) \frac{dp}{dt}. \quad (251)$$

where v_1 — velocity of liquid, led to the velocity of working

plunger.

Velocity v_1 can be expressed through the pressure in the form

$$10^3(\rho_a - \rho) - (\xi_{T_1} + \xi_{M_1})v_1^2 = 0; \quad v_1 = \sqrt{\frac{(\rho_a - \rho) \cdot 10^3}{\xi_{T_1} + \xi_{M_1}}}.$$

Substituting the obtained value of v_1 in equation (251), after conversions we will obtain

$$dt = Q_0 \left(\frac{1}{E_s} + \epsilon' \right) \frac{\sqrt{\xi_{T_1} + \xi_{M_1}}}{10 \sqrt{10} F_p} \cdot \frac{d\rho}{\sqrt{\rho_a - \rho}}.$$

Page 256.

Integrating, we will obtain

$$t = Q_0 \left(\frac{1}{E_s} + \epsilon' \right) \frac{\sqrt{\xi_{T_1} + \xi_{M_1}}}{10 \sqrt{10} F_p} \int_0^{\rho_a} \frac{(-2 \sqrt{\rho_a - \rho})}{1} d\rho.$$

After the substitution of integration limits we will obtain

$$t = Q_0 \left(\frac{1}{E_s} + \epsilon' \right) \frac{\sqrt{\xi_{T_1} + \xi_{M_1}}}{10 \sqrt{10} F_p} 2 \sqrt{\rho_a}. \quad (252)$$

Formula (252) it is possible to use also for determining the time of decompression in the working cylinders. In this case it is thought that the bleeding to the discovery/opening of filler valve occurs through the drain valve of water distributor. In the formula in this case instead of ρ_a it is necessary to substitute value p , with which the filler valve is opened/disclosed:

$$p = \rho_a \left(1 - \frac{1}{F} \right),$$

where F - area of filler valve;

f - area of the plunger of the auxiliary cylinder, with the help of which filler valve is opened/disclosed.

Approximate computation of the elements/cells of the hydraulic system of vertical press with the pump-and-battery drive.

During the first stage of the design of hydraulic press the geometry of conduits/manifolds is not yet revealed, but only approximately known the lengths of conduits/manifolds. Therefore it is necessary to make the approximate computation of the diameters of plungers and conduits/manifolds. The methodology of this calculation is given below.

For determining the diameters of the recurrent and balancing plungers we compile an equation of the static equilibrium of the crosshead during its lift and dropping.

Pressures in the filler tank and the storage battery/accumulator in the process of the work of press vary depending on the flow rate of them of working fluid.

During the compilation of the equation of the equilibrium of the crosshead for the period of lift we will take maximum value for the pressure in filler tank ($p_{n_{max}}$) and minimum value for the pressure in

storage battery/accumulator ($p_{a_{min}}$), and for the period of dropping, on the contrary, minimum value for the pressure in filler tank ($p_{n_{min}}$) and maximum value for the pressure in storage battery/accumulator ($p_{a_{max}}$).

Taking into account that the effort/force, developed with the recurrent and balancing cylinders, during their motion varies insignificantly, the pressure differential between the storage battery/accumulator and the recurrent and balancing cylinders we choose from the condition of the maximum power, developed with cylinders with the constant load, which functions on the plungers.

Page 257.

Drop value of the pressure, which corresponds to the maximum power, developed with cylinders, we find from expression (218).

Respectively the value of the pressure, necessary for overcoming fluid friction against the conduit/manifold for the cycle of motion of cross-beam upward (recurrent course), we take:

for the conduit/manifold of the recurrent and balancing cylinders

$$\Delta p = \frac{1}{3} p_a;$$

for the filler conduit/manifold

$$\Delta p = p_n - (1 + 2).$$

Taking into account that the speeds of recurrent (upward) and idle (down) running of cross-beam are usually chosen equal, and the rates of flow of liquid in the discharge lead are accepted 1.5-2 times lower than rate of flow in delivery conduit, the pressure differential for the discharge lead of pull-backs we take as the equal to

$$\Delta p = \frac{\frac{1}{3} \rho_{a \min}}{1.5^2 + 2^2} \approx \frac{1}{10} \rho_{a \min}.$$

With the conditions accepted and the designations the equations of the static equilibrium of the crosshead will be written in the form:

for the period of the recurrent course

$$\begin{aligned} G + \frac{\pi}{4} D_p^2 [\rho_{a \max} + \rho_{a \min} - (1 + 2)] = \\ = \frac{\pi}{4} \left[\frac{2}{3} \rho_{a \min} (D_o^2 + D_y^2) \right]; \end{aligned} \quad (253)$$

for the idle period

$$G + \frac{\pi}{4} D_p^2 (1 + 2) = \frac{\pi}{4} \left[\frac{1}{10} \rho_{a \min} D_o^2 + \left(\rho_{a \max} + \frac{1}{3} \rho_{a \min} \right) D_y^2 \right], \quad (254)$$

where G - weight of the crosshead with the instrument and the working plungers in kg.

During the approximate computation with the weight of the

plungers of the recurrent and balancing cylinders, and also by the friction of plungers against the sealing rings it is disregarded.

Further let us designate:

$$\alpha = \frac{p_{a \min}}{p_{a \max}}; \quad \beta = \frac{p_{n \min}}{p_{n \max}};$$

$$A = G + \frac{\pi}{4} D_p^2 [p_{n \max} + p_{n \min} - (1 \div 2)];$$

$$B = \frac{\pi}{4} \left(\frac{2}{3} \alpha p_{a \max} \right);$$

$$C = G + \frac{\pi}{4} D_p^2 (1 \div 2);$$

$$D = \frac{\pi}{4} \left(\frac{1}{10} \alpha p_{a \max} \right);$$

$$E = \frac{\pi}{4} \left(\frac{1}{3} \alpha + 1 \right) p_{a \max}.$$

Page 258.

With the adopted designations equations (253) and (254) will be written in the form

$$A = B (D_x^2 + D_y^2); \quad (253')$$

$$C = D D_x^2 + E D_y^2. \quad (254')$$

From these equations we find

$$D_x = \sqrt{\frac{AD - BC}{B(D - E)}}; \quad (255)$$

$$D_y = \sqrt{\frac{A - BD_x^2}{B}}. \quad (256)$$

In the absence of the balancing cylinders the diameter of the plungers of pull-backs is determined according to equation (253), assuming/setting in it $D_y = 0$. In this case in order to ensure

positive pressure in the working cylinders in the idle period, it is necessary to determine required pressure in the pull-backs for this period by equation (254):

$$\Delta p = \frac{4}{\pi} \frac{\left[G + \frac{\pi}{4} D_p^2 (1 + 2) \right]}{D_s^2}$$

The diameters of conduits/manifolds we determine from the equations of continuity and flow of liquid on the conduit/manifold:

$$v_m d_m^2 = v D^2 \cdot 10^{-2}; \quad (257)$$

$$v_m = \frac{1}{\sqrt{\lambda \frac{L \cdot 100}{d_m} + \xi}} \sqrt{2g \cdot 10 \Delta p}. \quad (258)$$

The maximum permissible rate of flow of liquid in the conduit/manifold we limit by strength condition of conduit/manifold, allowing/assuming the possibility of emergence in the conduit/manifold of straight/direct hydroshock.

Page 259.

From the known formula of Zhukovskiy (151) we have

$$v_{m \max} = \frac{10 \cdot g n p}{\sigma} \approx \frac{n p}{13}$$

In given formulas (257) (258) and (151) it is marked:

v_m — the rate of flow of liquid in the conduit/manifold in m/s;

d_m — diameter of the corresponding conduit/manifold in cm;

v - velocity of cross-beam for the appropriate cycle of motion in cm/s;

D - given diameter of the plungers of the corresponding cylinders in cm;

p - operating pressure in the appropriate line in kg/cm²;

Δp - the pressure differential between the storage battery/accumulator (filler tank) and the corresponding cylinders in kg/cm²;

n - safety factor of conduit/manifold;

n_p - permissible excess of pressure in the conduit/manifold as a result of the hydroshock according to strength conditions of conduit/manifold in kg/cm²;

ξ - sum of the coefficients of the local resistance of the corresponding line of conduit/manifold.

Values n of the safety factor of conduit/manifold can be taken

as equal ones from 0.5 to 1.

The values of the coefficients of local resistances ξ according to experimental data, obtained during the study of stamping machines, carried out TsNIITMASH, tentatively can be accepted as the following:

for the filler conduit/manifold ... 15-30.

for delivery conduit of recurrent and working cylinders ...
140-280.

for the discharge lead of recurrent and working cylinders ...
60-120.

for the conduit/manifold of the balancing cylinders ... 50-100.

From equations (257) and (258) we obtain

$$\frac{vD^5 \cdot 10^{-4}}{d_m^5} = \frac{1}{\sqrt{\lambda \frac{L \cdot 100}{d_m} + \xi}} \sqrt{2g \cdot 10 \Delta p}.$$

After conversions we have

$$d_m^5 - ad_m - b = 0, \quad (259)$$

where it is marked

$$a \approx \frac{v^5 \cdot D^5 \xi}{2 \cdot 10^4 \Delta p}; \quad b = \frac{v^5 D^4 \lambda L}{2 \cdot 10^4 \Delta p}.$$

The values of coefficients of a and b of equation (259) at the previously values Δp accepted will be:

for the filler conduit/manifold

$$a = \frac{v^3 D_p^4 \xi}{2 \cdot 10^8 [\rho_{\min} - (1+2)]}; \quad b = \frac{v^3 D_p^4 \lambda L}{2 \cdot 10^4 [\rho_{\min} - (1+2)]};$$

for the forcing and discharge leads of the working cylinders

$$a = \frac{v^3 D_p^4 \xi}{2 \cdot 10^8 \cdot \rho_{\max}}; \quad b = \frac{v^3 D_p^4 \lambda L}{2 \cdot 10^4 \cdot \rho_{\max}};$$

for delivery conduit of the recurrent (and balancing) cylinders

$$a = \frac{1.5 v^3 D_p^4 \xi}{10^8 \cdot \rho_{\min}}; \quad b = \frac{1.5 \cdot v^3 D_p^4 \lambda L}{10^4 \cdot \rho_{\min}};$$

for the discharge lead of the pull-backs

$$a = \frac{v^3 D_p^4 \xi}{2 \cdot 10^8 \cdot \rho_{\min}}; \quad b = \frac{v^3 D_p^4 \lambda L}{2 \cdot 10^8 \cdot \rho_{\min}}.$$

Equation (259) most simply is solved graphically.

By obtained values d_m , using formula (257), we determine the value of the rates of flow of liquid in the conduits/manifolds.

If obtained velocities v_m for delivery conduits of working and pull-backs will not satisfy condition $v_{m_{\max}} < \frac{np}{13}$, then it is necessary

to increase value ξ in formula (258).

In terms of values d_m can be selected the diameters of the flow areas of the corresponding valves, in this case the valve diameter

$$d_v = (0,8 \div 0,9) d_m.$$

Let us note that we took the drop/jump between the storage battery/accumulator and the working cylinders equal to complete maximum pressure in the storage battery/accumulator, i.e., that the cross-beam of press acquires maximum speed in the absence of load on the cross-beam.

Therefore during the calculation of the diameter of delivery conduit of working cylinders it is necessary to be assigned by the maximum possible velocity of cross-beam v_{max} at the pressure in the cylinders, equal to zero.

The velocity of cross-beam at the pressure interesting in the working cylinders p will be determined according to the expression

$$v = \frac{v_{m_{max}} d_m^2}{D_p^3} \sqrt{\frac{p_{a_{max}} - p}{p_{a_{max}}}}$$

After the determination of all sizes/dimensions of conduit/manifold and fittings adjustable on it, it is necessary to produce verifying calculation employing procedure presented above.

Page 261.

Example. To calculate press by effort/force $P=10000$ t with following data: the maximum operating pressure in storage battery/accumulator $p_{a_{max}} = 320$ kg/cm², minimum $p_{a_{min}} = 228$ kg/cm²; the length of delivery conduit of the working, recurrent and balancing cylinders, and also the discharge lead of pull-backs $L=50$ m. The length of filler conduit/manifold is $L=20$ m. Speed of idle and recurrent running of cross-beam $v=20$ cm/s. The maximum speed of cross-beam with the feeding of working cylinders from the storage battery/accumulator (in the absence of load on the cross-beam) $v=20$ cm/s. Weight of the crosshead (including the weight of working plungers, instrument, etc.) $G=180$ t. Maximum pressure of liquid in filler tank $p_{n_{max}} = 8$ kg/cm², minimum $p_{n_{min}} = 6$ kg/cm².

To determine the diameters of the plungers of the recurrent and balancing cylinders and the bores of conduit/manifold.

Under given conditions we will have the following value of coefficients in equations (253) and (254):

$$A = 55,7 \cdot 10^4; B = 151; C = 24,28 \cdot 10^4;$$

$$D = 22,6; E = 326.$$

According to equation (255) and (256) we determine the given diameters of balancing and pull-backs $D_b = 22,9$ cm; $D_p = 56,2$ cm.

During the installation/setting up of two balancing and two pull-backs the diameters of their plungers will be equal to

$$D_v = \frac{D_v}{\sqrt{2}} = 16,2 \text{ cm};$$

$$D_s = \frac{D_s}{\sqrt{2}} = 39,8 \text{ cm}.$$

Respectively the efforts/forces, developed by the balancing and pull-backs, will be equal to

$$P_{v \max} = \frac{\pi D_v^2}{4} \cdot 320 = 132 \text{ m};$$

$$P_{v \min} = \frac{\pi D_v^2}{4} \cdot 288 = 118,5 \text{ m};$$

$$P_{s \max} = \frac{\pi D_s^2}{4} \cdot 320 = 792 \text{ m};$$

$$P_{s \min} = \frac{\pi D_s^2}{4} \cdot 288 = 715 \text{ m}.$$

Page 262.

We further determine coefficients in equation (259) at the extreme recommended values ξ . The obtained values are given in Table 17.

Knowing the coefficients of equation (259), we solve it we graphically and find the values interesting us of the diameters of conduit/manifold. The values of the diameters of conduits/manifolds are given in Table 18.

Table 17. Values of coefficients of a and b.

(1) Линии трубопроводов	a	b
(2) Наполнительный трубопровод рабочих цилиндров: ξ = 15 ξ = 30	12 · 10 ⁶ 24 · 10 ⁶	48 · 10 ⁶ 48 · 10 ⁶
(3) Напорная линия рабочих цилиндров: ξ = 140 ξ = 280	14,3 · 10 ⁶ 28,6 · 10 ⁶	15,2 · 10 ⁶ 15,2 · 10 ⁶
(4) Сливная линия рабочих цилиндров: ξ = 60 ξ = 120	6,15 · 10 ⁶ 12,3 · 10 ⁶	15,2 · 10 ⁶ 15,2 · 10 ⁶
(5) Напорная линия возвратных цилиндров: ξ = 140 ξ = 280	29 · 10 ³ 58 · 10 ³	31,1 · 10 ³ 31,1 · 10 ³
(6) Сливная линия возвратных цилиндров: ξ = 60 ξ = 120	41,5 · 10 ³ 83 · 10 ³	103,5 · 10 ³ 103,5 · 10 ³
(7) Напорная линия уравновешивающих цилиндров: ξ = 50 ξ = 100	28,6 57,2	86 86

Key: (1). Lines of conduits/manifolds. (2). Filler conduit/manifold of working cylinders. (3). Forcing line of working cylinders. (4). Drain line of working cylinders. (5). Forcing line of pull-backs. (6). Drain line of pull-backs. (7). Forcing line of the balancing cylinders.

Table 18. Values of the diameters of conduits/manifolds.

(1) Трубопроводы	(2) d_m в см
(3) Наполнительный трубопровод рабочих цилиндров: $\xi = 15$ $\xi = 30$	34,0 40,0
(4) Напорная линия рабочих цилиндров: $\xi = 140$ $\xi = 280$	20,0 23,2
(5) Сливная линия рабочих цилиндров: $\xi = 60$ $\xi = 120$	16,5 19,2
(6) Напорная линия возвратных цилиндров: $\xi = 140$ $\xi = 280$	7,6 8,9
(7) Сливная линия возвратных цилиндров: $\xi = 60$ $\xi = 120$	8,6 9,8
(8) Напорная линия уравновешивающих цилиндров: $\xi = 50$ $\xi = 100$	2,8 3,2

Key: (1). Conduits/manifolds. (2). in cm. (3). Filler conduit/manifold of working cylinders. (4). Forcing line of working cylinders. (5). Drain line of working cylinders. (6). Forcing line of pull-backs. (7). Drain line of pull-backs. (8). Forcing line of the balancing cylinders.

Page 263.

The values of the rate of flow of liquid in the conduits/manifolds are given in Table 19.

Table 19. Values of the rate of flow of liquid in the conduits/manifolds.

(1) Трубопроводы	(2) v_m в м/сек	(3) Максимально возможное ударное давление в линии в кг/см ² $\Delta p = 13v_m$	(4) Необходимый коэффициент запаса прочности трубопроводов $n = \frac{\Delta p}{P_{атах}}$
(5) Наполнительный трубопровод рабочих цилиндров: $\xi = 15$ $\xi = 30$	6.9 5.0	— —	— —
(6) Напорная линия рабочих цилиндров: $\xi = 140$ $\xi = 280$	20.0 14.8	260 192	0.812 0.6
(7) Сливная линия рабочих цилиндров: $\xi = 60$ $\xi = 120$	29.3 21.6	— —	— —
(8) Напорная линия возвратных цилиндров: $\xi = 140$ $\xi = 280$	10.95 8.0	142 104	0.443 0.325
(9) Сливная линия возвратных цилиндров: $\xi = 60$ $\xi = 120$	8.55 6.55	— —	— —
(10) Напорная линия уравновешивающих цилиндров: $\xi = 50$ $\xi = 100$	13.4 10.3	— —	— —

Key: (1). Conduits/manifolds. (2). in m/s. (3). Maximally possible impact pressure in the line in kg/cm² (4). Necessary safety factor of conduits/manifolds (5). Filler conduit/manifold of working cylinders. (6). Forcing line of working cylinders. (7). Drain line of working cylinders. (8). Forcing line of pull-backs. (9). Drain line of pull-backs. (10). Forcing line of the balancing

cylinders.

Page 264.

In the given calculations by us two extreme values ξ entered and therefore it is obtained in terms of two values of the diameters of conduits/manifolds to the rates of flow of liquid.

Designer must produce the selection of the value ξ during the calculation of conduits/manifolds taking into account the predicted geometry of conduit/manifold, construction/design and quantity of fittings installed on it.

Cavitation.

Under the known conditions for flow of liquid, in its separate zones, the pressure can fall so, that from the liquid the steam-gas or steam bubbles will begin to be selected, i.e., the continuity of liquid will be broken. These bubbles (caverns - the zone of vacuum), being moved together with the liquid, enter the high-pressure area, where they are destroyed.

The simplified representation about the cavitation can be obtained from the examination of flow of liquid on the

conduit/manifold with the considerably changing section/cut (Fig. 243).

According to the equation of the steady motion

$$\frac{p}{\gamma} + \frac{v^2}{2g} + h_r = \text{const.},$$

where p - pressure in the section/cut of flow in question;

v - average/mean rate of flow in this section/cut;

h_r - loss of head in the section before the section/cut in question.

According to the equation of the steady motion of liquid with the low sizes/dimensions of section/cut 2-2 (Fig. 243) the velocity in it grows so, that pressure p , will become below vapor pressure of liquid and from it the steam bubbles will begin to be selected.

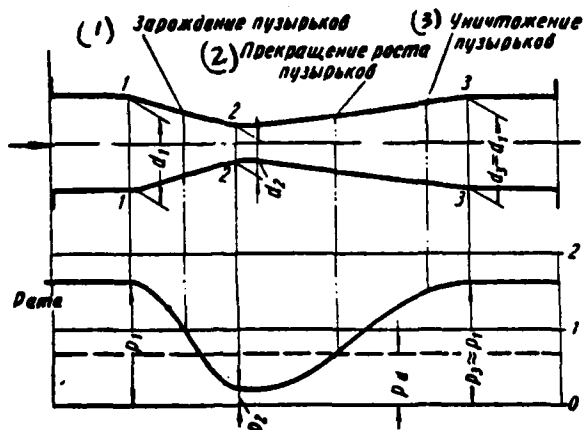

Fig. 243. Flow diagram of liquid in the narrowed conduit/manifold and the graph of a change of the pressure in the flow.

Key: (1). Origin/conception/initiation of bubbles. (2). Cessation/discontinuation of an increase in the bubbles. (3). Destruction of bubbles.

Page 265.

Thus, the phenomenon of cavitation is observed with a considerable local increase in the velocity of fluid flow and with the subsequent reduction/descent in this velocity.

On the basis of this representation about nature of cavitation it is considered as the value, which characterizes intensity its,

dimensionless quantity - number of cavitation

$$\lambda = \frac{p - p_d}{\frac{v^2}{2g}}, \quad (260)$$

where p_d - pressure of the vapors of liquid at this temperature;

p - uniform pressure after the place of origin of cavitation.

From expression (260) it follows that the number of cavitation is relationship of pressure differential, with which is destroyed the cavitation, to velocity head, which caused its formation.

Cavitation occurs in the cases of an abrupt change in the flow area in the conduit/manifold, in the apparatuses established/installed on it; when, in their housings, of sharp edges or abrupt changes in the section/cut are present.

In the region of compressed jet cross-sectional area proceeds as the "squeezing" of flow from the walls of channel with the formation of the discharged "dead zones", filled with the steam bubbles, which vanish during braking of flow. Sudden drop of pressure in the flow of the moving/driving liquid can occur in the zones, situated after the locking organs/controls (negative hydroshock), and also in the blind branch conduits or in the blind drilling, available in the housings of the distributing valve devices.

As a result of cavitation occurs the erosion of the surfaces, which limit flow in the places, adjacent to the zone, in which the destruction of bubbles occurs. The porous structure of the worn surface is the characteristic feature of wear from the cavitation.

The observed destruction of the parts of the distributing valve devices indicates that the cavitation is one of the basic reasons for destruction.

Fig. 244 shows the bronze bushing of the throttle valve of horizontal bar-tube press with effort/force 1000 t, of the worker from the pump-and-battery station with the pressure 200 kg/cm².



Fig. 244. Bronze bushing of the valve distributor of horizontal bar-tube press with effort/force 1000 t after 2 months of operation.

Page 266.

Bushing was in operation 2 months. On the surface of bushing extensive destruction is visible.

Fig. 245 shows the valves of the distributor of stamping machine by effort/force 10000 t; the worn places are isolated with black/ferrous color. From the drawing it is evident that the places of the greatest destruction are arranged/located in the lower part of the saddle of throttle valve and after it, i.e., it is direct after the zone of the high velocities, and also in the "dead zone" after

the drain valve.

Fig. 246 shows the destroyed saddle from the throttle valve of distributor (Fig. 245).

Fig. 247 shows the bronze part of valve with the through gas inclusion, which has characteristic porous surface.

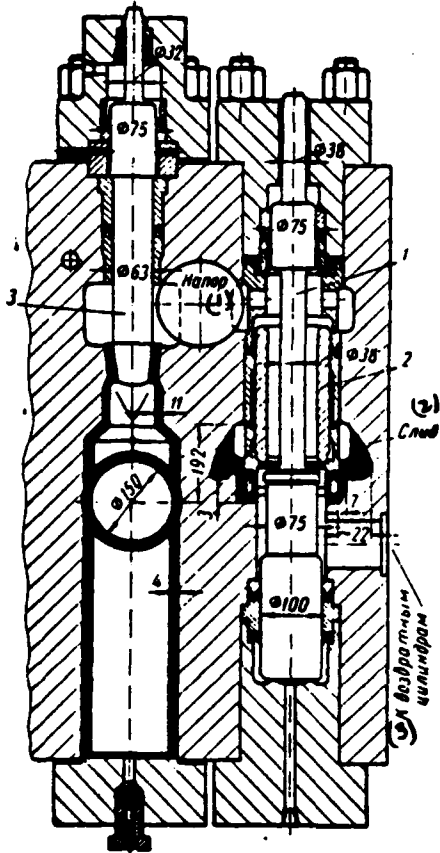

Fig. 245. The valves of the distributor of stamping machine by effort/force 10000 t: 1 - pressure valve of pull-backs; 2 - the drain valve of pull-backs; 3 - choke/throttle.

Key: (1). Pressure. (2). Drain. (3). To the pull-backs.



Fig. 246.



Fig. 247.

Fig. 246. Saddle of throttle valve.

Fig. 247. Bronze part of valve distributor.

Page 267.

Gas inclusion is arranged/located below zone of the maximum speeds of liquid. Analogous destruction undergo the shafts of valves (Fig. 248).

Physical nature of both the very phenomenon of cavitation and of the erosion caused by it is very complicated and up to now still completely revealed.

The erosion, which accompanies cavitation, in the opinion of the majority of researchers, is the corollary of purely mechanical effects (hydroshocks, which appear during the destruction of bubbles). Some researchers, however, recognizing that the mechanical effects are the basic source of erosion, consider that the electrical discharges in the cavity/cavitation bubbles cause the oxidation processes, which reinforce erosion.

In the practice of the construction of the apparatuses of the hydraulic system of press it is necessary to create flow regimes, which exclude cavitation or reducing it to the minimum, and to also choose the materials, which possess the greatest resistance to cavitation.

The creation of the modes/conditions, during which the cavitation in this hydraulic apparatus can be reduced to the minimum, in the absence of the sufficiently precise theory of the emergence of this phenomenon requires at present apparatus testing in nature. Model test does not give satisfactory results. Data, obtained on the model, it is impossible to transfer to nature in view of the fact that for the phenomenon of cavitation it is not yet created theory of similitude.

It is established/installed, that with an increase in the

sizes/dimensions hydraulically of machine or construction the emergence of cavitation occurs at the higher values of a number of cavitation (i.e. at the lower speed of flow). The temperature of water has a considerable effect on the phenomenon of the cavitation erosion also. With an increase in the temperature from 0 to 50° destruction occurs more intensely, while with further increase in the temperature the intensity of destruction is depressed also near the boiling point the erosion ceases.

Thus, the conventional index (cavity/cavitation number) insufficiently reflects the cavity/cavitation properties of flow and its ability to cause erosion, since it does not consider the scale of flow, the temperature of water, saturation by its undissolved gases, etc. In other words, the law of similarity for the cavitating flow is not described by the expression of a number of cavitation (260).



Fig. 248. Erosion of valve, caused by the high velocity of liquid.

Page 268.

Meanwhile only the setting of a certain law of similarity and index, corresponding to it, sufficiently which closely explains the objectively existing phenomenon, can be basis for the detailed study and the forecast of the emergence of this phenomenon. Otherwise a precise foresight is impossible and any new construction/design, doubtful with respect to cavitation, will have to undergo the experimental check full size.

The difficulty of setting the law of similarity for the cavitating flow can be explained by the fact that as a result of the

presence in liquid of a considerable number of caverns the very liquid of the cavitating flow it is not possible to already consider as common, to which the laws of the hydraulics of solid liquids extend. The liquid of the cavitating flow is necessary to consider as certain hypothetical, i.e., assumed continuous medium, which possesses considerable elasticity and at the same time which differs in a whole series of properties from the gas.

The creation of the modes/conditions, during which the cavitation does not appear, can occur only in those flows, where it proves to be possible either not to allow/assume considerable rates of flow or to guarantee the pressure, sufficient for maintaining air being present in the water in the dissolved state.

In the distributive high-pressure valves for the hydraulic press installations/settings up deceleration of liquid is possible only when in this valve or generally in the examined/considered circuit of the diagram of control of press is not required to throttle fluid flow. However, in a whole series of the practical cases this throttling/choking of flow is the method, most advantageous from the point of view of the effectiveness of the control system. The examination of the samples/specimens of different parts of valve control, worn with the work in the functioning press installations/settings up, shows that the erosion from the cavitation

can strike parts, about which considerable rate of flow causes the turbulence of flow, which generate, in turn, separation type cavitation.

Fight with the cavity/cavitation destruction in the valves of hydraulic presses can be conducted in the direction of the creation of the distributors, in which the control valves play the role only of the intercepting/detaching pressure organs/controls, with the transmission of the function of the control of velocity with the degree of the discovery/opening distributing valves on the special throttling valves. Must be converted attention to the rational shaping of the separate parts of valves, which removes or which lowers to the minimum the possibility of forming the separation cavitation; it is necessary to search for the materials, capable of the prolonged resistance of the cavitation erosion.

Simulation of hydraulic phenomena.

During the calculation of hydrodynamics of press installations/settings up is necessary the knowledge of the experimental drag coefficients of the elements/cells of drainage systems, data on which are at present accumulated insufficiently.

The use/application of the for the first time designed constructions/designs of the distributing valve and locking devices and fittings, not investigated to the resistance, excludes the possibility of conducting calculating the velocities of the motion of liquid in the conduits/manifolds with the necessary precision/accuracy also of the calculation of the velocities of the motion of transfer plunger. Many of the formulas of hydrodynamics, which they use during the calculation, they are approximate. The complexity of hydraulic lines, and also constructing/designing the separate elements/cells, in many instances makes calculations too bulky and frequently not feasible. Therefore during the design of hydraulic press installations/settings up it is necessary to use the data, obtained during observation either study of the working installations/settings up or to construct and to investigate models.

For the correct comparison of the parameters of installations/settings up, different in the sizes/dimensions, forces and power, it is necessary to have in mind the laws of mechanical similarity.

For the complete mechanical similarity of systems (phenomena) their geometric, kinematic and dynamic similarity is necessary.

Such systems, in which between their linear dimensions there is a constant relationship/ratio, are called geometrically similar.

If we designate through L_n and L_m the respectively significant dimensions of nature and model, then the relation

$$\frac{L_n}{L_m} = m_L$$

indicates the geometric graphic scale of model, which indicates in how often its sizes/dimensions they are reduced in comparison with nature.

The ratios of areas and volumes will be respectively equal to

$$\frac{F_n}{F_m} = m_L^2; \quad \frac{Q_n}{Q_m} = m_L^3.$$

In the geometrically similar systems with the observance of the equality of the pressures of liquid the relation of the static efforts/forces, which function in the system, will be equal to the square of the graphic scale

$$\frac{\rho F_n}{\rho F_m} = m_L^2.$$

For observing the kinematic similarity of flows it is necessary that for its congruent points they would be kept constants of the relation

$$\frac{T_1}{T_2} = m_T; \quad \frac{v_1}{v_2} = m_v; \quad \frac{g_1}{g_2} = m_g,$$

where T_1 - transit time with the particle of the flow (with index 1)

of the segment of trajectory L_1 ;

T_2 - transit time with the corresponding particle of kinematically similar flow (with index 2), segment of trajectory L_2 , geometrically similar and oriented to segment L_1 ;

v_1, v_2, g_1 and g_2 - velocity and the acceleration of congruent points of two kinematically similar flows.

In this case the velocities and accelerations must be represented by the vectors equally oriented in the space.

Page 270.

For the dynamic similarity of flows the equality of the dimensionless expressions

$$\frac{v^2}{gL} = Fr; \quad \frac{dv}{v} = Re.$$

is necessary. Fr The first expression is called in the hydraulics Froude number and answers the condition of similarity of flows under the action only gravitational force, and the second expression - Reynolds number answers the condition of the similarity of flows under the action of the forces of internal friction (viscosity/ductility/toughness).

Since in the flow the forces of different categories function, cannot be obtained complete similarity.

In the hydraulic presses at the high velocities of the motion of liquid in the conduits/manifolds, caused by high pressures in the end sections/cuts of conduits/manifolds, and the relatively low pressures, which appear from a difference in the levels of conduits/manifolds, the basic criterion of the mechanical similarity of two flows is Reynolds number.

However, the observance of Reynolds numbers during the study of different hydrodynamic phenomena, which occur in the hydraulic system of press, is extremely difficult under laboratory conditions.

During the determination of Reynolds number as the significant dimension is considered the bore of conduit/manifold, and therefore during the simulation of phenomena under laboratory conditions, where it is difficult to use with the large-slot manifolds, it is necessary to create the high velocities of flow, which is connected with the need for having powerful/thick installations/settings up.

In the hydropresses the average/mean rates of flow of liquid in the conduit/manifold reach to 40 m/s; in this case the diameters of the conduits/manifolds used with the sizes/dimensions of 100-150 mm

are not rare phenomenon. With the wish to have laboratory unit with the conduit/manifold by the diameter of 20 mm it would be necessary to create flow with a speed of $40 \times 100 - 150 / 20 > 300$ m/s, for which necessarily enormous pressure.

Let us point out even on the difficulty of study on the models of the hydraulic impact, which appears in the system of press.

For obtaining the similarity with the hydroshock during the construction of model with graphic scale m_L , with which the period of its conduit/manifold will be equal to $\tau_m = \frac{c_m}{m_L}$, it is necessary to close control valves and to open/disclose in the very short time, i.e., m_L once is less than in the full-scale machine, for which it is 0.1-0.5 s.

Therefore the study of hydrodynamics of press installations/settings up is expedient to carry out in the full-scale machines.

Page 271.

Chapter 5.

PUMPS OF HYDRAULIC PRESS INSTALLATIONS/SETTINGS UP.

General information.

In the hydraulic press installations/settings up find use the pumps of all forms: plunger crank; plunger rotational with the radial and axial arrangement of plungers; plunger eccentric; blade; spiral; gear and centrifugal.

Plunger crank pumps are applied mainly during the pump-and-battery drive and are constructed to the large supplies and the pressures. Most powerful/thickest of the constructed pumps of this type has a supply 5000 l/min at a pressure 350 kg/cm² and consumes the power of 4750 kW. The widest use received three-plunger horizontal pumps with the supply to 1000 l/min at pressure by 200 and 320 kg/cm².

Rotational-plunger pumps are made with a large number of plungers, they have many structural/design varieties and are constructed mainly for the work on mineral oil. Rotational-plunger pumps are applied predominantly for the batteryless drive. The powers of such pumps reach to 3000 kW. Most widely used are rotational-plunger pumps to the pressure to 175 kg/cm² and supply to 200 l/min.

Screw pumps are constructed with the pressure to 175 kg/cm² and the supply at these pressures to 500 l/min. To the considerably greater supplies (to 5000 l/min) they are constructed at low pressures (10-15 kg/cm²).

In the hydraulic press installations/settings up the screw pumps obtained limited application due to their relatively low volumetric efficiency (70-75%) with the work on the high pressure and the absence of the possibility of the control of supply.

Blade and gear pumps, which are constructed to the relatively small supplies and the pressures to (150 l/min; 10-70 kg/cm²), in the hydraulic press installations/settings up are applied mainly for the auxiliary services and sometimes for main drive of small according to

the power presses.

Page 272.

Centrifugal pumps (low-pressure single-stage) in the press installations/settings up have use for the secondary functions as, for example, for the filling of the tanks of preliminary filling in the closed system of the circulation of water in the installation/setting up and sometimes for the preliminary filling of master cylinders. In the latter case during the working stroke of press the centrifugal pump usually is thrown to the feeding of high-pressure pumps.

Multistage pumps by pressure to 100-120 kg/cm² are applied in the forging presses with the battery installation/setting up and sometimes for the independent drive of the presses of low powers (to 1000 t).

Plunger crank pumps are manufactured with relatively small series, mainly by press-building plants. Let us in more detail examine construction/design and calculation of plunger crank pumps.

Remaining pumps are produced by the specialized plants, which supply them for the most varied machines and the

installations/settings up. Therefore we give the information about the remaining pumps only in that volume, which is necessary for their selection during the design of hydraulic press installation/setting up.

GENERAL ARRANGEMENT BASIC PARAMETERS OF THE PLUNGER CRANK PUMPS

These pumps are made with the vertical and horizontal motion of plungers. According to a number of supplies in the cycle the pumps divide into the pumps of single and double action. The widest use received three-plunger pumps of single action. Vertical pumps are made relative to low powers - to 150 kW and with a large number of plungers (5- and 7- plunger by power to 800 kW. Exemplary/approximate characteristics and overall dimensions of vertical three-plunger pumps are given in Tables 20 and 21.

Table 20. Exemplary/approximate characteristics of vertical three-plunger pumps.

(1) Ход плун- жера в мм	(2) Диаметр плунжера в мм	(3) Рабочее давление в кг/см ²	(4) Число хо- дов в ми- нуту	(5) Подача в л/мин	(6) Мощность электро- двигателя в кВт	(7) Размеры труб (внут- ранный диаметр) в мм	
						(8) всасываю- щей	(9) нагнет- ательной
100	20	300	150	13	8,2	25	25
100	25	200	150	20	8,2	25	25
150	20	200	130	17	10,3	25	25
150	25	200	130	26	11	32	32
200	30	300	115	45	27,2	32	32
200	35	200	115	60	24,2	38	32
250	35	300	105	70	42	50	38
250	45	200	105	125	50	64	50

Key: (1). Piston stroke in mm. (2). Diameter of plunger in mm. (3). Working Working in kg/cm². (4). Number of courses per minute. (5). Supply in l/min. (6). Power of electric motor in kW. (7). Sizes/dimensions of tubes/tubas (bore) in mm. (8). sucking in. (9). plenum.

Page 273.

Horizontal three-plunger pumps have the widest use. The construction/design of contemporary three-plunger pump with the supply 500 l/min to the pressure 200 kg/cm² is shown in Fig. 249 and 250. Exemplary/approximate characteristics and dimensions of horizontal pumps are given in Tables 22 and 23.

Powerful/thick pumps are frequently made by the two-plunger ones of double action (Fig. 251 and 252).

The cranks of the shaft in these pumps are located at an angle of 90° .

Table 21. Exemplary/approximate sizes/dimensions of vertical pumps (Fig. 253).

(1) Ход плун- жера в мм	(2) Размеры в мм						
	A	B	C	D	E	F	G
100	320	—	740	370	560	965	470
150	370	—	1000	520	780	1420	575
200	495	—	1320	685	915	1730	760
250	560	1385	—	1030	1210	2540	1450

Key: (1). Piston stroke in mm. (2). Sizes/dimensions in mm.

Table 22. Exemplary/approximate characteristics of horizontal three-plunger pumps.

(1) Ход плун- жера в мм	(2) Диаметр плунжера в мм	(3) Рабочее давление в кг/см ²	(4) Число хо- дов в ми- нуту	(5) Подача в л/мин	(6) Мощность электро- двигателя в кВт	(7) Внутренний диаметр труб в мм	
						(8) всасыва- ющей	(9) нагнета- тельной
300	40	300	100	100	59	64	38
300	55	200	100	200	74	76	38
375	55	300	95	230	132	76	50
375	70	200	95	375	148	100	76
450	70	300	95	450	264	100	76
450	90	200	95	750	296	150	80

Key: (1). Piston stroke in mm. (2). Diameter of plunger in mm. (3). Operating pressure in kg/cm². (4). Number of courses per minute. (5). Supply in l/min. (6). Power of electric motor in kW. (7). Tube bore in mm. (8). sucking in. (9). plenum.

Table 23. Exemplary/approximate sizes/dimensions of horizontal three-plunger pumps (Fig. 254).

(1) Ход плун- жера в мм	(2) Размеры в мм							
	A	B	C	D	E	F	G	H
300	3250	2870	1320	585	765	1270	1855	815
375	3530	3100	1455	660	840	1460	2085	915
450	3835	3320	1625	740	920	1650	2380	1070

Key: (1). Piston stroke in mm. (2). Sizes/dimensions in mm.

Page 274.

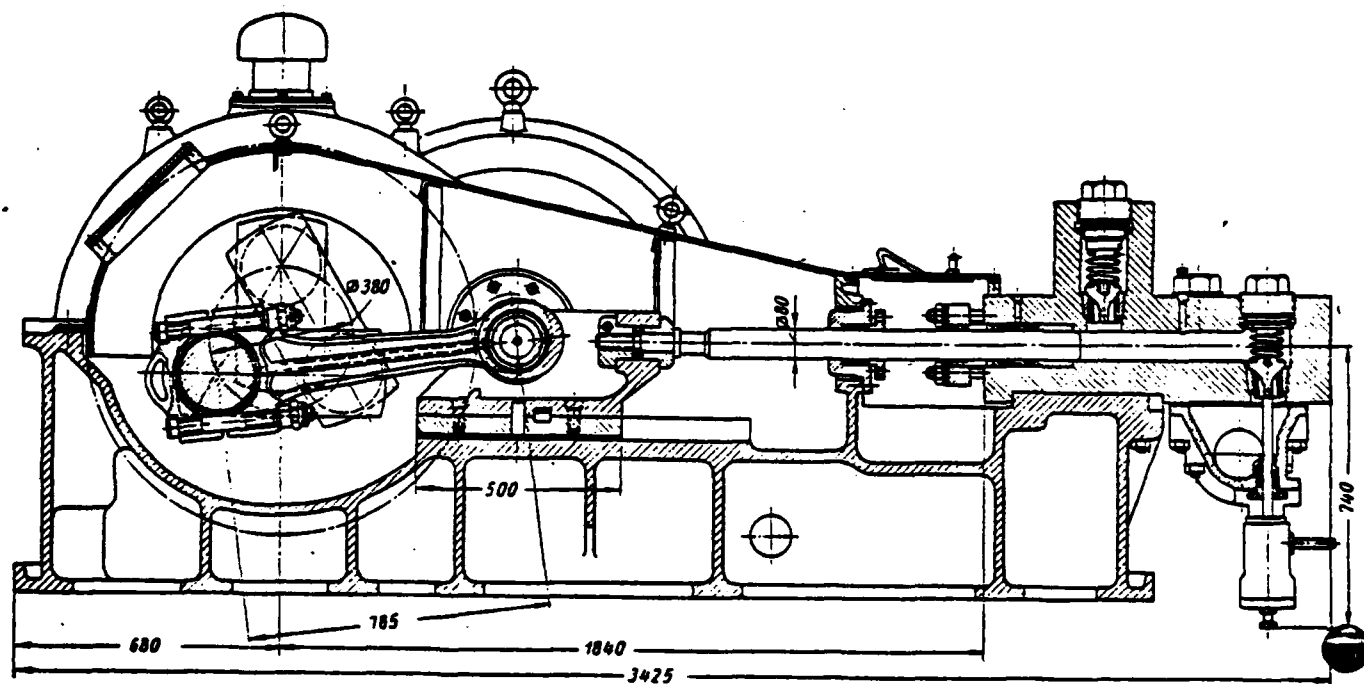

Fig. 249. The longitudinal section of horizontal pump with the supply 500 l/min to the pressure 200 kg/cm².

Page 275.

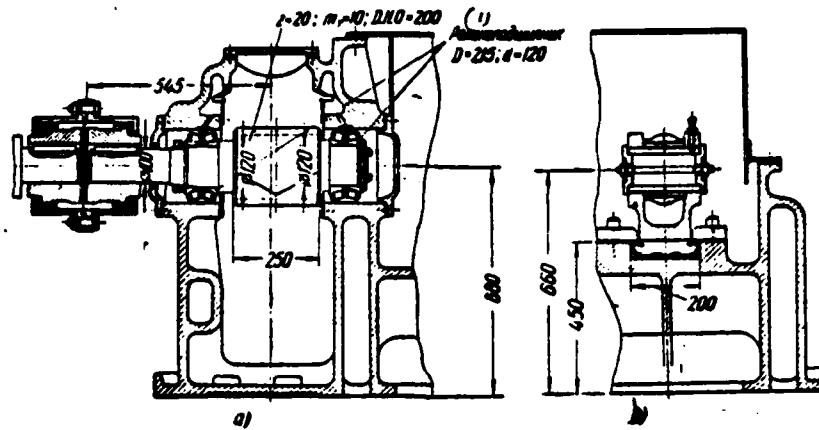

Fig. 250. Sections/cuts of horizontal pump with the supply 500 l/min to the pressure 200 kg/cm² a) on the drive shaft; b) on the slider.

Key: (1). Roller bearing.

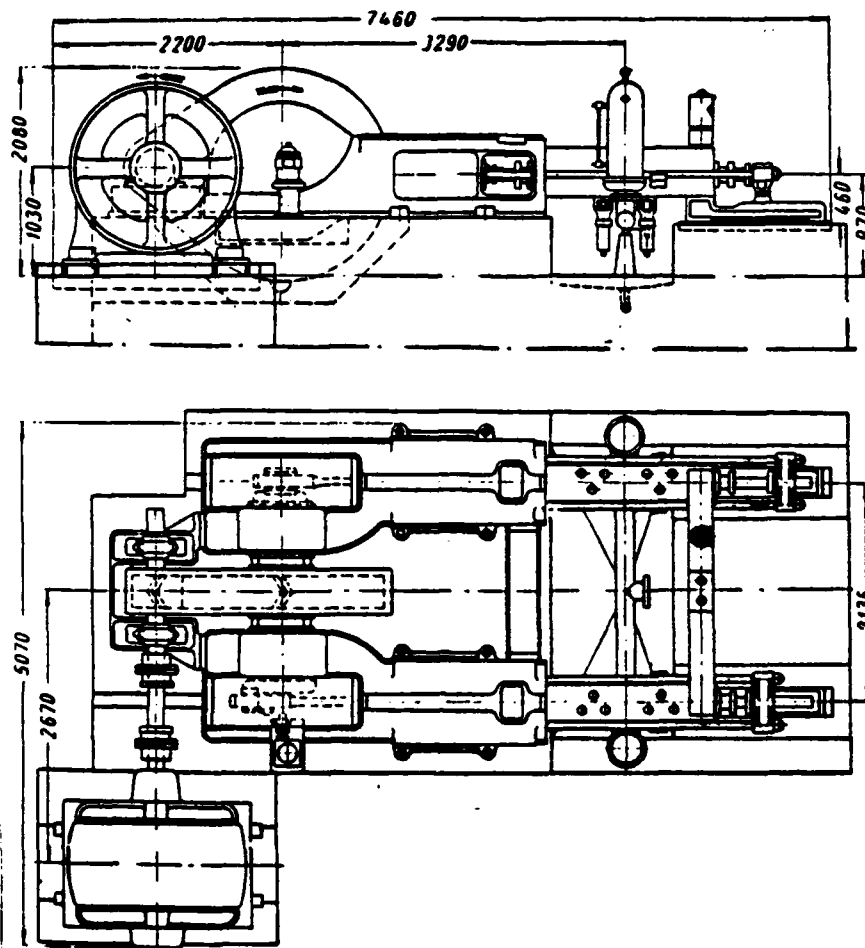

Fig. 251. Horizontal two-plunger double-acting pump.

Page 276.

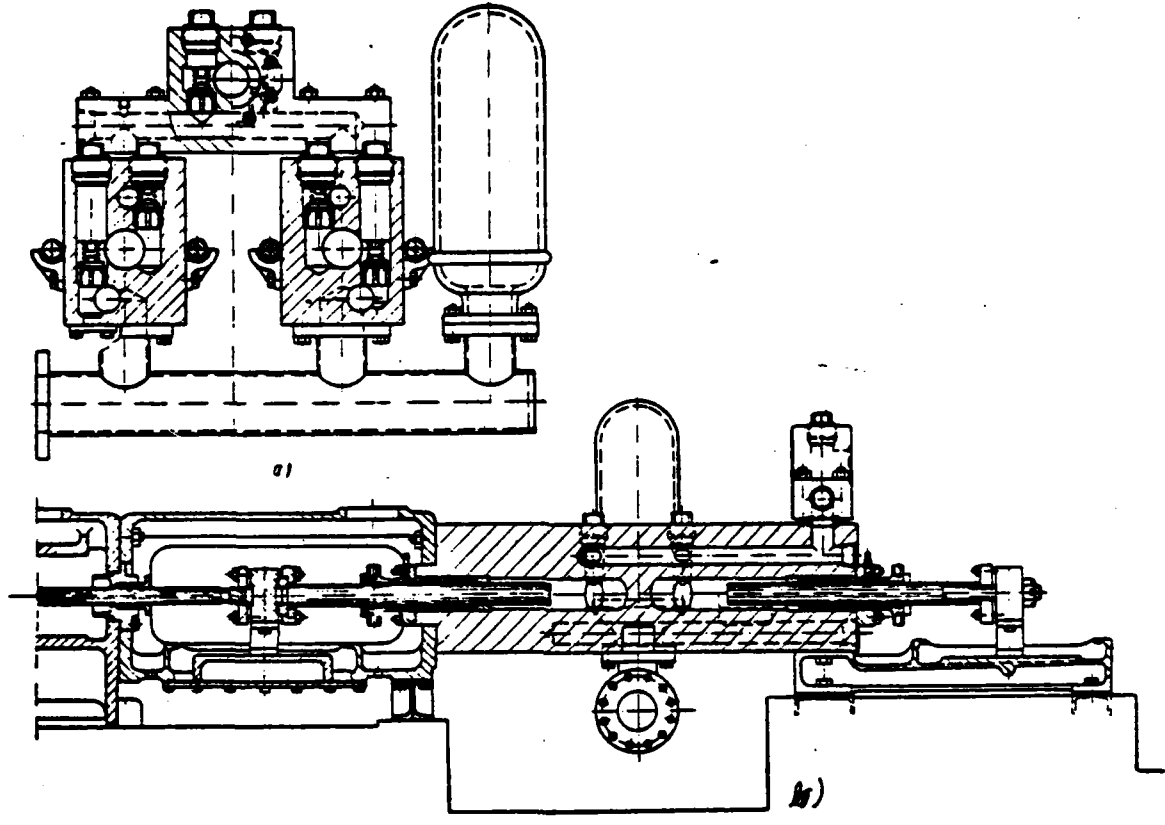

Fig. 252. Sections/cuts on cylinder blocks of horizontal two-plunger double-acting pump: a) transverse; b) longitudinal.

Page 277.

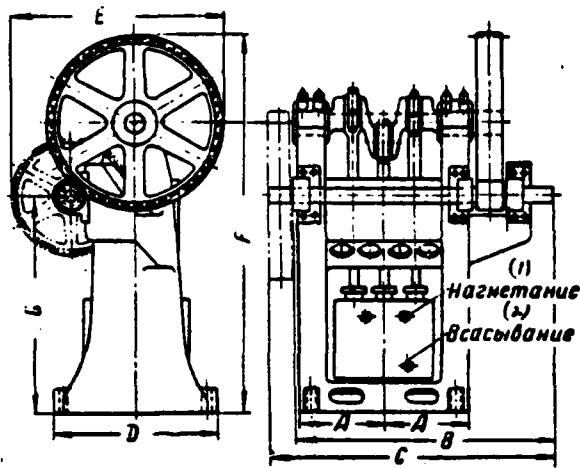

Fig. 253. Vertical three-plunger pump.

Key: (1). Forcing. (2). Suction.

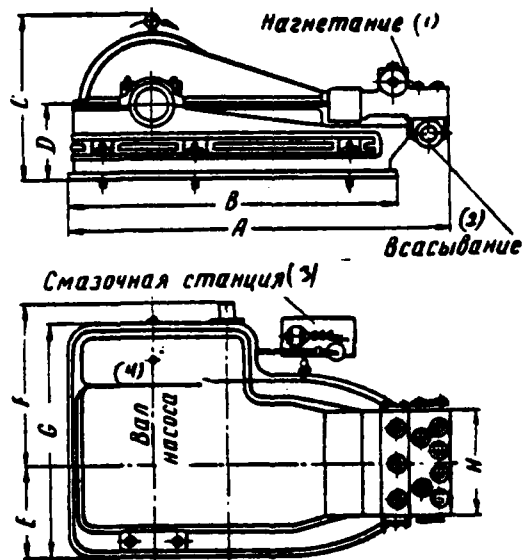

Fig. 254. Horizontal three-plunger pump.

Key: (1). Forcing. (2). Suction. (3). Lubricating station. (4). White resists of pump.

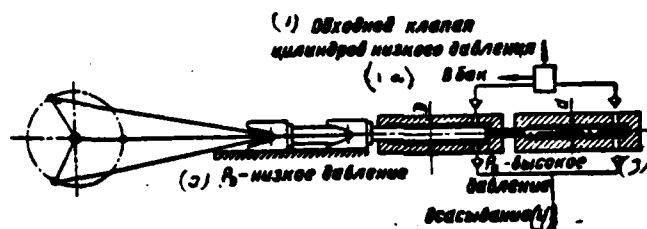

Fig. 255. Schematic of three-plunger two-stage pump.

Key: (1). Bypass valve of low-pressures cylinder. (1A). In the tank.
(2). - low pressure. (3). High pressure. (4). Suction.

Page 278.

For some presses with the large working course and alternating load on the cross-beam (for example, for the baling machines) are applied the horizontal three-plunger pumps with two steps/stages of supply and the pressures, obtained due to the use stepped p to the diameter of plungers (Fig. 255). Transition/transfer from the greater supply to smaller in the pump is accomplished/realized automatically on the pressure in the system. The construction/design of this pump and mechanism of its switching from one supply to another is shown in Fig. 256 and 257.

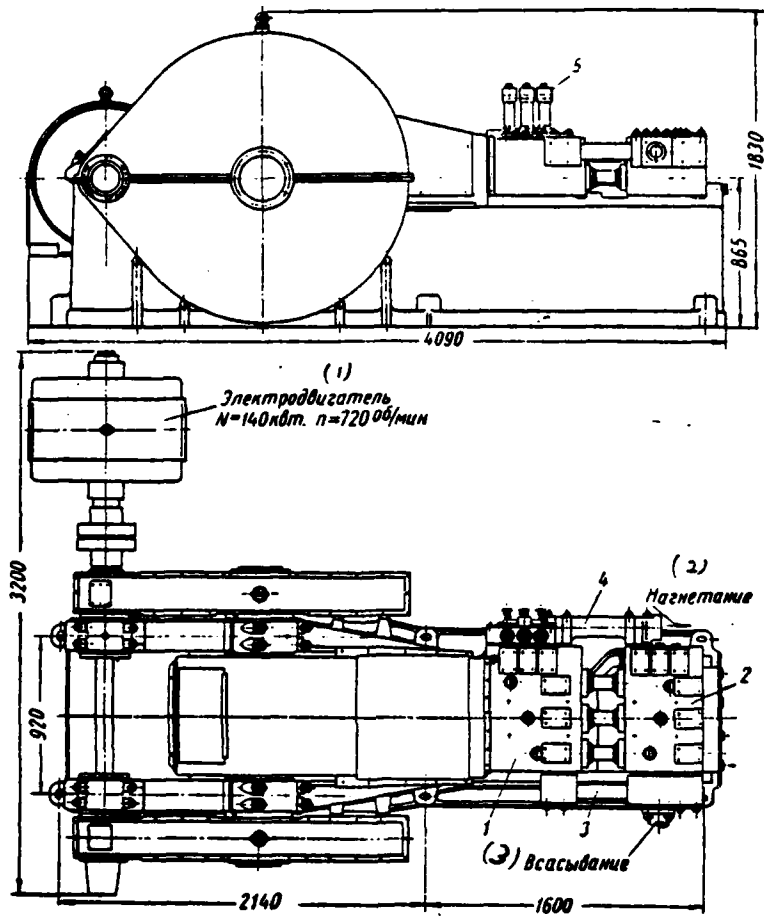

Fig. 256. The general view of three-plunger pump with two steps/stages of supply and pressure - 1200/360 $\frac{1}{\text{min}}$; 50/175 kg/cm^2 :
 1 - cylinder block of low-pressure; 2 - cylinder block of high-pressure; 3 - suction header; 4 - discharge header; 5 - safety valves.

Key: (1). Electric motor N=140 kW n=720 r/min. (2). Forcing. (3).

Suction.

Page 279.

The average/mean supply of plunger pump is determined from the formula

$$V = \frac{zfsn}{1000} \eta_v \quad (261)$$

where z - number of plungers; f - area of plunger in cm^2 ; s - piston stroke in cm; n - number of revolutions of crankshaft per minute; η_v - volumetric efficiency of pump.

The value of piston stroke of pumps is selected of the condition of obtaining their average speed $v=ns/3000$ not above 3 m/s.

At the higher velocities of plungers the sealings/packings/compactions rapidly are worn.

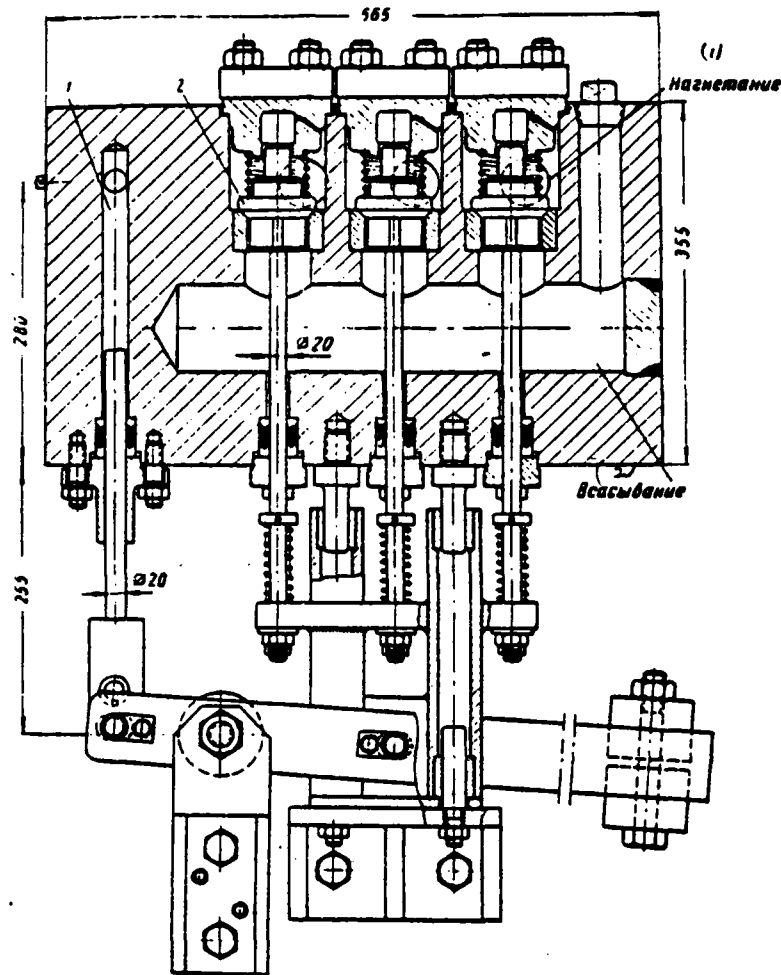

Fig. 257. The construction/design of the mechanism of the automatic changeover of three-plunger two-stage pump for the work at the second pressure stage and supply: 1 - high-pressure cavity (for the step/stage); 2 - the intake valves of first stage of the supply of pump (low pressure).

Key: (1). Forcing. (2). Suction.

Page 280.

For the vertical pumps the value of piston stroke usually is found in the repartitions/conversions 6-20 cm and for horizontal 30-60 cm.

The number of revolutions of crankshaft (number of throws of plump per minute) is taken as the equal to 95-180 per minute. Rapidity of pumps is limited by the conditions of sucking the liquid into the cylinder block, and also by the work of intake valves (by durability of valves and saddles). With an increase in the number of revolutions of shaft it is necessary, for guaranteeing a good filling of cylinder block, to increase the flow area of intake valves, i.e., to depress the average/mean rate of flow of liquid in the valves and to decrease the value of valve lift.

The average/mean rate of flow of liquid in the intake valves is accepted not more than 3 m/s, and in the plenum ones - not more than 6 m/s.

At the indicated values of the number of strokes of pump, rates of flow of liquid indicated in the intake valves and with the

correctly specific pressure in the end section/cut of inlet tubing the volumetric efficiency of pump it composes 0.92-0.94.

Driving/homing shaft horsepower of pump is equal to

$$N = \frac{pW}{612\eta_o\eta_m}, \quad (262)$$

where p - pressure of the supplied liquid in kg/cm^2 ;

η_o - mechanical efficiency of pump, equal to 0.8-0.85.

The power of the electric motor of pump usually is selected by 10-15% higher than calculated than the nonuniformity of the supply of pump and the nonuniformity of pressure in the forcing line is considered.

NONUNIFORMITY OF THE SUPPLY OF PLUNGER PUMPS.

Three-plunger pump. From the theory of crank mechanism it is known that the velocity of point B (Fig. 258), i.e., in this case the velocity of plunger, depending on the angle α of the rotation of crank, with a sufficient for practical purposes precision/accuracy is determined according to the equation

$$v = r\omega \left(\sin \alpha \pm \frac{\kappa}{2} \sin 2\alpha \right), \quad (263)$$

where ω - angular velocity of shaft; r - crank throw; $\kappa = r/L$ - ratio of crank throw to the length of connecting rod.

For three-plunger pump, in which the cranks of shaft are arranged/located at angle of 120° , speed of plungers are equal to

$$\left. \begin{aligned} v_1 &= r\omega \left(\sin \alpha \pm \frac{\kappa}{2} \sin 2\alpha \right); \\ v_2 &= r\omega \left[\sin (\alpha + 120) \pm \frac{\kappa}{2} \sin 2 (\alpha + 120) \right]; \\ v_3 &= r\omega \left[\sin (\alpha + 240) \pm \frac{\kappa}{2} \sin 2 (\alpha + 240) \right]. \end{aligned} \right\} \quad (264)$$

Page 281.

Respectively the supplies of plungers are equal to

$$W_1 = fv_1; \quad W_2 = fv_2; \quad W_3 = fv_3. \quad (265)$$

where f - area of plunger.

With the change α from 60 to 120° supply is accomplished/realized only by two plungers, the third draws in liquid into a block-cylinder.

In this section of the rotation of shaft, i.e., at $60^\circ < \alpha < 120^\circ$, the supply of pump is equal to $W_1 + W_2$, i.e.

$$W = fr\omega \left\{ \sin \alpha + \sin (\alpha + 120) + \frac{\kappa}{2} [\sin 2\alpha - \sin 2 (\alpha + 120)] \right\}. \quad (266)$$

For the determination of the maximum supply of pump let us make the derivative of expression (266) equal to zero.

After conversions we will obtain the expression

$$\cos \alpha + 2\kappa \cos^2 \alpha - \kappa = \sqrt{3} \sin \alpha (1 - 2\kappa \cos \alpha).$$

After raising the right and the left parts of this expression into the square, and disregarding members, which contain κ^2 , we will obtain

$$8\kappa \cos^3 \alpha - 4 \cos^3 \alpha - 10\kappa \cos \alpha + 3 = 0. \quad (267)$$

The solution of equation in general form is cumbersome.

Solving it for the particular values $\kappa=0$; 0.1; 0.2; 0.3, we will obtain

$$\begin{aligned} &\text{with } \kappa=0 \\ &\alpha = 30^\circ; W_{\max} = fr\omega. \end{aligned}$$

Minimum value W_{\min} will be at $\alpha=0^\circ$; 60° ; 120° and so forth;

$$W_{\min} = \frac{\sqrt{3}}{2} fr\omega.$$

Average/mean supply of the pump

$$W_{cp} = \frac{3}{\pi} fr\omega.$$

Then the relative nonuniformity of the supply of pump is equal to

$$\delta = \frac{W_{\max} - W_{\min}}{W_{cp}} = \frac{1 - \frac{\sqrt{3}}{2}}{\frac{3}{\pi}} \approx 14.1\%.$$

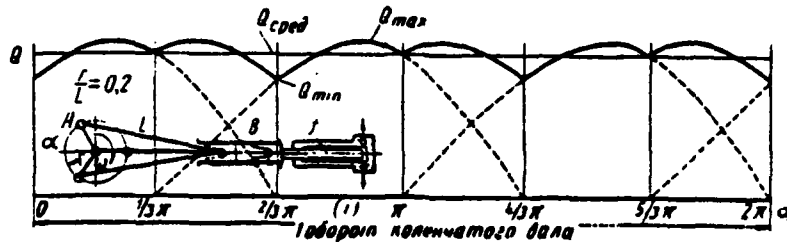

Fig. 258. Graph of the supply of three-plunger pump.

Key: (1). 1 revolution of crankshaft.

Page 282.

With $\kappa=0.3$ by graphical solution of equations (267) we find $\alpha=48.5^\circ$, and from (266)

$$W_{\max} = 1.038fr\omega.$$

The minimum values of supply will be different: at $\alpha=0^\circ$

$$W_{\min} = 0.995 fr\omega;$$

at $\alpha=60^\circ$

$$W_{\min} = 0.73fr\omega.$$

Maximum nonuniformity of supply to $\delta=31.4\%$. With $\kappa=0.1$ we have

$$\alpha = 35.5^\circ; W_{\max} = 1.004fr\omega; W_{\min} = 0.823fr\omega; \delta \cong 18.9\%$$

with $\kappa=0.2$

$$\alpha = 42.5^\circ; W_{\max} = 1.01fr\omega; W_{\min} = 0.96fr\omega; \delta \cong 24\%$$

Two-plunger double-acting pump. In section of $0^\circ < \alpha < 90^\circ$ (Fig. 259) the general/common/total supply of pump is equal to

$$W = W'_1 + W'_2 = f(v'_1 + v'_2),$$

where

$$v'_1 = r\omega \left(\sin \alpha + \frac{\kappa}{2} \sin 2\alpha \right);$$

$$v'_2 = r\omega \left\{ -\sin(270 + \alpha) - \frac{\kappa}{2} \sin 2(270 + \alpha) \right\}.$$

Then

$$W = r\omega f \left\{ \sin \alpha - \sin(270 + \alpha) + \frac{\kappa}{2} (\sin 2\alpha - \sin 2(270 + \alpha)) \right\}. \quad (268)$$

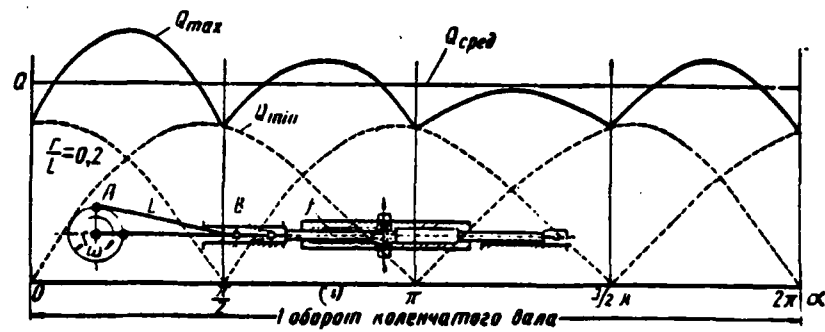

Fig. 259. Graph of the supply of two-plunger double-acting pump.

Key: (1). 1 revolution of crankshaft.

Page 283.

Having differentiated the written expression and after making its equal to zero, we find the value α , at which the supply will be maximum, and through the obtained value α we find

$$W_{max} = fr\omega (1,414 + \kappa).$$

Minimum supply pump it will give with $\alpha=0^\circ; 180$ and so forth; its value will be equally

$$W_{min} = r\omega f.$$

Maximum nonuniformity of the supply of the pump

$$\begin{aligned} \delta &= \frac{W_{max} - W_{min}}{W_{cp}} = \\ &= \frac{[(1,414 + \kappa) - 1] \pi}{4} \approx 32,5\%. \end{aligned}$$

For guaranteeing the steady work of pump on the inlet tubing before the pumps air chambers are established/installed.

In the two-plunger double-acting pumps, which have relatively greater nonuniformity, on the forcing line in the unit of the pump spring compensators are established/installed, one of constructions/designs of which is shown in Fig. 260.

The volume of air in the cap/hood (during fluctuation of pressure in it, equal to approximately 10%) tentatively can be determined according to the formula

$$Q > c \frac{W}{n}, \quad (269)$$

where W - supply of pump in l/min;

n - number of revolutions of pump per minute;

c - coefficient, depending on the type of pump; for three-plunger pump $c=0.1-0.15$, for the two-plunger double-acting pump $c=0.4-0.6$.

The volume of spring compensator on the forcing line can be determined according to the same formula, accepting in it coefficient of c 10 times less.

PRESSURE IN AN INLET TUBING OF PLUNGER PUMP.

In order to ensure filling of the cylinder block of pump, in the suction line it is necessary to create a sufficient pressure.

Let us examine the case of the feeding of pump from the tank, arranged/located at the level Z (Fig. 261).

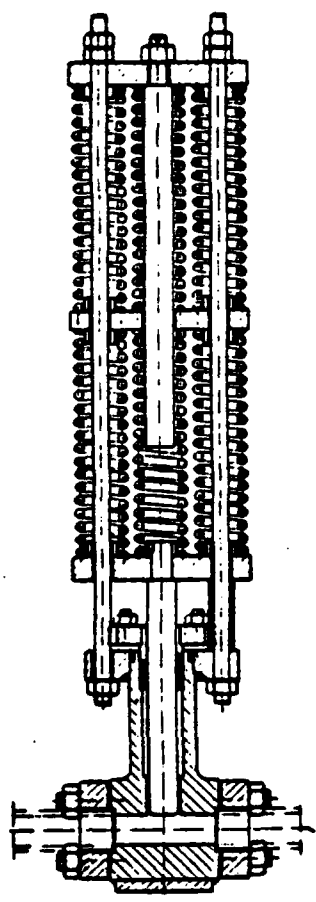

Fig. 260. Construction/design of the spring compensator of the nonuniformity of the supply of pump.

Page 284.

With the feeding of plunger pump by centrifugal pump Z it will indicate the necessary pressure on the flange of centrifugal pump.

Let us designate:

H_x - pressure in the cylinder block during the suction;

H_0 - atmospheric pressure;

v - velocity of plunger;

L - led to the diameter of pump piston length of inlet tubing;

ξ - total drag coefficient of inlet tubing, led to the velocity of plunger;

h_x - resistance of the intake valve of pump.

The equation of unsteady motion of liquid in the inlet tubing takes the form

$$H_x = H_0 + Z - h_x - \left[\frac{l}{g} \cdot \frac{dv}{dt} + (1 + \xi) \frac{v^2}{2g} \right]. \quad (270)$$

We consider h_x a constant value; then in the brackets the variable/alternating/variable terms of equation prove to be by prisoners.

At the maximum value of the expression, included in the brackets, H_x has minimum value. In this case value $H_{x_{min}}$ must be more

than the value of the pressure of the vapors of the drawn in liquid.

If this condition is not observed, occurs breakage of flow and incomplete filling of cylinder block.

We investigate expression in the brackets to the maximum. Let us designate this expression through y :

$$y = \frac{l}{g} \cdot \frac{dv}{dt} + \frac{1+\xi}{2g} v^2. \quad (271)$$

In expression (271) the greatest value has inertia pressure $l/g \cdot dv/dt$, which let us calculate separately. We will calculate velocity head $v^2/2g$ according to the average/mean value of the velocity in the inlet tubing.

AD-A139 822

HYDRAULIC PRESSES(U) FOREIGN TECHNOLOGY DIV
WRIGHT-PATTERSON AFB OH B V ROZANOV 09 MAR 84
FTD-ID(RS)T-1207-83

7/10

UNCLASSIFIED

F/G 13/9

NL

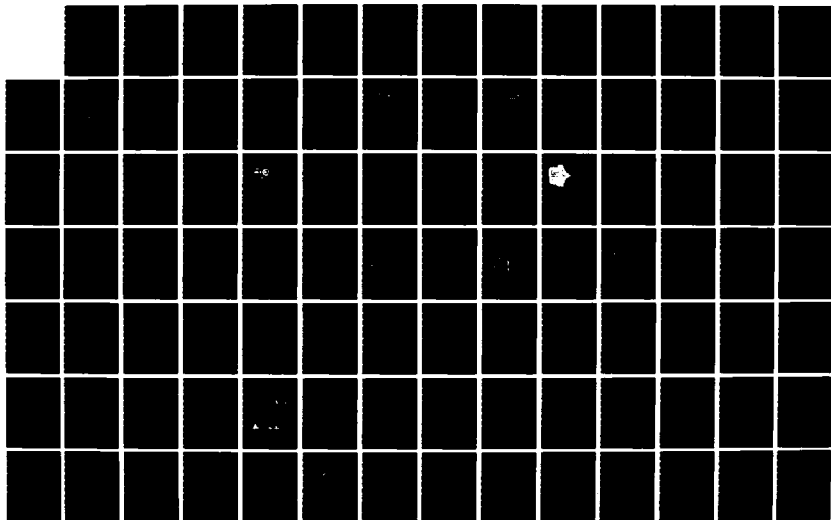

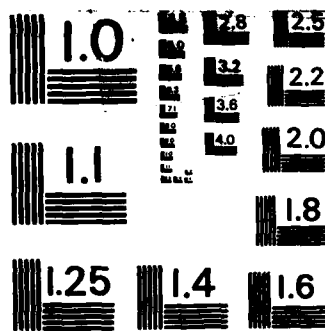

MICROCOPY RESOLUTION TEST CHART
NATIONAL BUREAU OF STANDARDS-1963-A

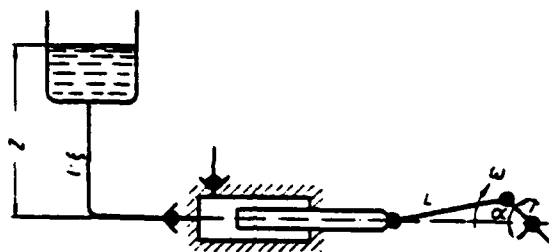

Fig. 261. Design diagram for determining the pressure in the inlet tubing of pump.

Page 285.

Let us represent the expression of velocity head in the form

$$\frac{l}{g} \cdot \frac{dv}{dt} = c \frac{l}{g} n v. \quad (272)$$

For three-plunger pump

$$\frac{dv}{dt} = r \omega^2 [\cos \alpha + \cos (\alpha + 120) + \kappa \cos 2\alpha + \kappa \cos 2(\alpha + 120)].$$

Bracketed expression has a maximum with $\alpha=0^\circ$, and the value of it is equal $1+k/2$:

$$v = v_{cp} = \frac{6rn}{60}.$$

Then value c in expression (272) will be equally

$$c = \pi^2 \frac{(1+\kappa)}{180}.$$

For the two-plunger double-acting pump by analogous computations we find

$$c = \frac{\pi^2}{120} (1 + 2\kappa).$$

During the computation of inertia pressure according to the

equation of unsteady motion, which does not consider the elasticity of liquid and conduit/manifold, the results are somewhat high.

The elasticity of liquid and conduit/manifold can be taken into consideration by the experimental coefficient of $m=1.5$.

Then we will finally have

$$Z = H_x + h_x - H_0 + (1 + k) \frac{v^2}{2g} + \frac{dv}{g} \quad (273)$$

The pressure of water vapors at different temperatures is given in Table 24.

The resistance of valve is tentatively taken as the equal to

$$h_x = 0,85 + 1 \mu.$$

During the installation/setting up on the suction line of air chamber of a sufficient volume value Z can be considerably reduced.

Table 24. Pressure of water vapors at different temperatures.

°C	0	10	20	30	40	50	60	70	80	90	100
H_x	0,052	0,115	0,236	0,429	0,746	1,25	2,023	3,176	4,820	7,145	10,336

Page 286.

CONSTRUCTION/DESIGN MATERIAL OF THE PARTS OF PLUNGER CRANK PUMPS.

Mounting is made by cast from cast iron, sufficient massive how

are prevented/warned the jolts of pump, called by its progressively/forwardly moving/driving masses.

Mounting relies on elongation and bend on total number of plungers; for three-plunger and two-plunger double-acting pumps the total effort/force of plungers is equal to $2fp$. Allowable stress during the calculation is taken by the equal to $70-80 \text{ kg/cm}^2$.

Crankshaft is made forged from steel of brands 35-45; they take allowable stress during the calculation (upon consideration of bend and torsion) as the equal to $400-500 \text{ kg/cm}^2$. Slide bearings or roller bearings are shaft bearings. In vertical pumps the slide bearings are made with dismountable/release ones of two parts, while in horizontal pumps - most frequently of four parts. With the execution of bearings of two parts the parting plane of bearings are located at angle. Shaft is installed on two or four supports. With two supports the small width of mounting is obtained, that the cylinder block makes it possible to make with permanent. The bearings with a diameter of more than 200 mm supply with lubrication under the pressure. During the installation on the roller shaft bearings usually has three supports (Fig. 262).

Connecting rods and sliders manufacture from the forged or cast steel. Connecting rods are relied on buckling. They take the length

of connecting rod as the equal to 4-5 crank throws. For the connecting rod pin they accept specific pressure $\sigma=90$ kg/cm², for the connecting-rod end (the crankpins of bearing) $\sigma=60-70$ kg/cm².

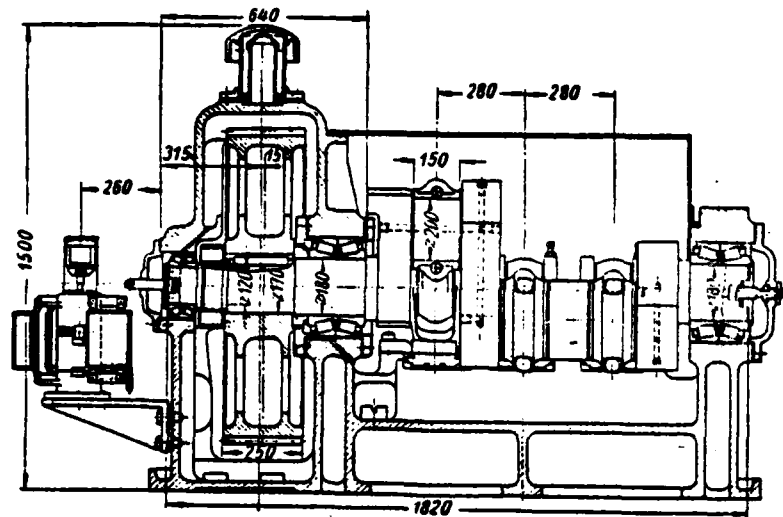

Fig. 262. Section/cut on the crankshaft of horizontal three-plunger pump with the supply 500 l/min to the pressure 200 kg/cm².

Page 287.

They make crosshead guide on the mounting in vertical pumps by cylindrical ones, in horizontal ones - cylindrical or flat/plane. They take specific pressure on the guides as the equal to 2-3 kg/cm².

Guides, for the purpose of control with the wear, are supplied with interchangeable sleeves or respectively cast iron flat/plane cover plates. Flat bearing are more available for the control with the wear and the assembly with the aid of the packing. Cylindrical guides are made without the control and with the wear of their

guiding sleeves they replace by new ones. Frequently instead of interchangeable sleeves or the cover plates of the sliding track of slider they babbitt. The compound of connecting rod with the slider is accomplished/realized by a cylindrical finger/pin or spherical fifth.

Plungers are manufactured from the alloy stainless steel of brands 3X13 or 2X13. Ram area must be sufficient solid and mirror smooth.

For preventing the one-sided wear of the gaskets of plunger, with the wear crosshead guide, the compound of plunger with the slider is made either by "that floating" in the radial direction or with possibility of the control of the position of plunger.

For sealing/packing/compaction of plungers in the cylinders are employed the manufactured from the specially machined technical fabric sleeves, the graphitized soft packing and sometimes ferrules.

Cylinder block is manufactured with forged from steel of brands 25-30. All channels and seats for the valves make with drilling and milling. Suction and plenum valves are furnished series/row or one above another.

Valves, saddles for them, springs and fasteners manufacture from

the stainless steel or from the high-quality bronze. Usually valves are made with the conical saddle and with the wing direction (Fig. 263). The sometimes intake valves for the purpose of obtaining large passage cross sections are made by circular ones, directed on the rod (Fig. 264). For best nip of valves the latter frequently supply with leather backings/blocks. Instead of one large-size valve in the majority of the cases they set several valves (VA of plenum ones and four sucking in or respectively three and six).

On the cylinder block for warning/preventing the formation of air "sacks" it is necessary to provide for drain valves.

All moving parts of the pump must abundantly be lubricated. During the flywheel drive oil pump usually is given from the crankshaft in order to ensure the lubrication of pump with its free landing run in the case of emergency with the electric system. With the lubrication of pumps from the central station, in the case of emergency in the electric system, one should have spare circuit of electric power supply in order not to leave pump without the lubrication with its course on the inertia, i.e., with the turned-off network/grid of electric power supply.

Each pump must have a no-load (idling) valve or a hoisting device of its intake valves during the period of no-load work (idling) of pump. Control of the pumps, adjusted with the storage battery/accumulator of liquid, is in detail examined in Chapter 6.

During the use/application of plunger crank pumps for the batteryless control linkage of pump must provide its translation/conversion into the no-load operation at the end of the working stroke of the press, when fluid flow rate ceases by press.

Special attention during the design of pumping station should be given the conduit/manifold and the fittings. The badly/poorly designed suction line is frequently the reason for the malfunctioning of pump and breakages in its valves and saddles. Both that sucking in and force main must be as far as possible short and straight lines with the minimum number of local resistance and have safety valves and manometers.

In the end of suction tube it is necessary to establish/install filter. The flow passage cross-sectional area of filter is taken as the equal to six cross-sectional areas of conduit/manifold or more.

For the disconnection of pump from the supply tank, to the period of the repair of pump, on the intake line should be

established/installed the catch. On delivery conduit near from the pump it is necessary to establish/install check valve for warning/preventing the suction through the delivery valves. Conduits/manifolds must have a sufficient quantity of supports, not connected with the pump.

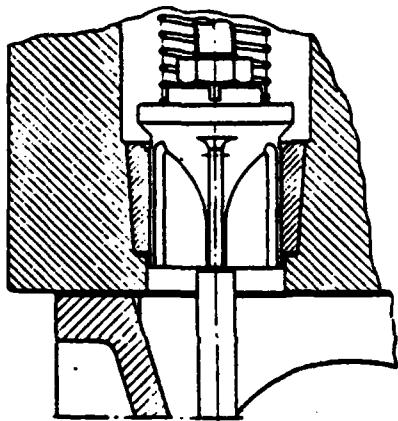

Fig. 263.

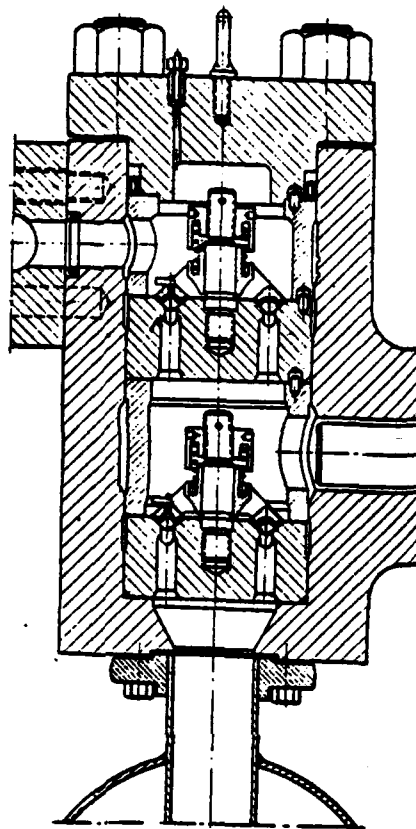

Fig. 264.

Fig. 263. Construction/design of the intake valve of pump.

Fig. 264. Construction/design of the suction and delivery valves of pump.

ROTATIONAL-PLUNGER PUMPS WITH THE RADIAL ARRANGEMENT OF PLUNGERS.

The schematic diagram of a rotational-plunger radial pump, which works on oil, is shown in Fig. 265, and standard design - in Fig. 266.

Pump has rotating rotor 1 with the radially arranged/located cylinders and plungers 2.

Distributive fixed axis 3, on which the rotor is rotated, has several channels, which are connected with the cylinders; through one series/row of channels 4 draw oil into the cylinders, and through another series/row of channels 5 oil is forced into high-pressure network/grid.

Plungers are forced against the conical rings of 6 rotating drums 7. Drum is rotated in the ball bearings, established/installed in unit 8. Unit can be moved on the guides in pump casing, establishing/installing drum 7 eccentrically with respect to the rotor. During the eccentric arrangement of drum on one half turn of rotor the plungers are moved from the center of rotor, drawing in oil into the cylinders, and on other half turn they are moved to the center of rotor, squeezing out oil into high-pressure line. The course of each plunger and, thus, the supply of pump they depend on

the amount of the displacement of unit 8 from the center of rotor (from the eccentricity of pump).

The rotor of pump is connected with drive shaft 9 by roller clutch 10, and in other constructions/designs by key.

In the described construction/design of pump the plungers in the radial direction from the center of rotor are moved due to the centrifugal force. High-pressure pumps also are constructed also with the forced conduct of plungers with the aid of the rollers (thinner/less frequent than plates). The construction/design of this pump is shown in Fig. 267.

Rotational-plunger pumps have relatively high efficiency. The average/mean value of the volumetric efficiency of rotational-plunger pumps composes 0.85-0.95 and general/common/total efficiency - 0.82-0.9.

Pumps are constructed with the constant and variable/alternating/variable supply to the pressure to 250 kg/cm² and the supply to 1000 l/min.

The exemplary/approximate characteristics of the constructed pumps are given in Table 25.

A change of supplying a rotational-plunger pump is accomplished/realized by a change in the position of the unit of pump with respect to the rotor (eccentricity of pump), while a change in the direction of the working flow of oil - by displacement of unit to opposite from the center of rotor side.

Spiral and worm-and-worm wheels are simplest of the mechanisms, used for the displacement of the unit of pump.

Depending on the designation/purpose of pump, propeller drive (or worm), moving unit, it is accomplished/realized by hand by a steering control or from the auxiliary electric motor.

Page 290.

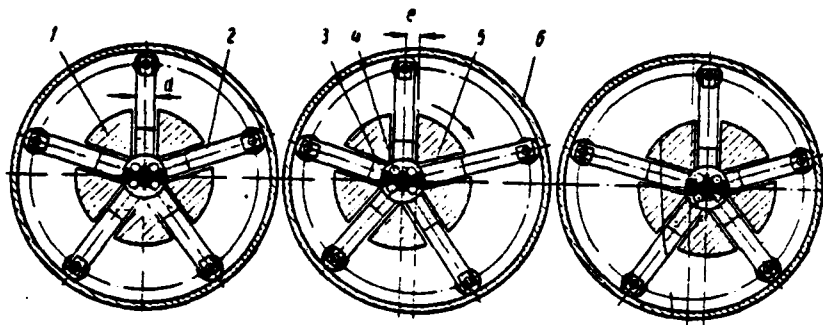

Fig. 265. Schematic diagram of a rotational-plunger pump with the radial arrangement of plungers.

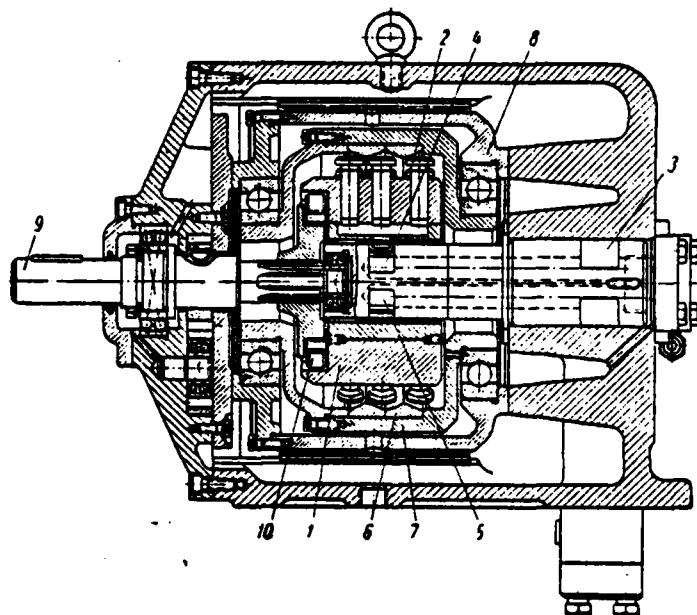

Fig. 266. The construction/design of a rotational-plunger pump with the freely moving plungers: 1 - rotor; 2 - plunger; 3 - distributive axis/axle; 4 - valve ports; 5 - plenum channels; 6 - conical carrier rings; 7 - rotating drum; 8 - unit of pump; 9 - drive shaft; 10 -

roller clutch.

Page 291.

Control of pilot engine is accomplished/realized either from push-button control group or it is automatic (with the aid of terminal switches, selsyn-motor, etc.).

The precision/accuracy of the control of supply depends on pitch of screw thread (or the gear ratio of worm-and-worm wheel).

A change in the supply from the maximum to zero in the pumps, which have a spiral pair-steering control, is accomplished/realized usually after $2\frac{1}{2}$, $-1\frac{1}{2}$, the rotation of steering control, and in the pumps, which have worm a pair-steering control, for 220-460 rotations of steering control.

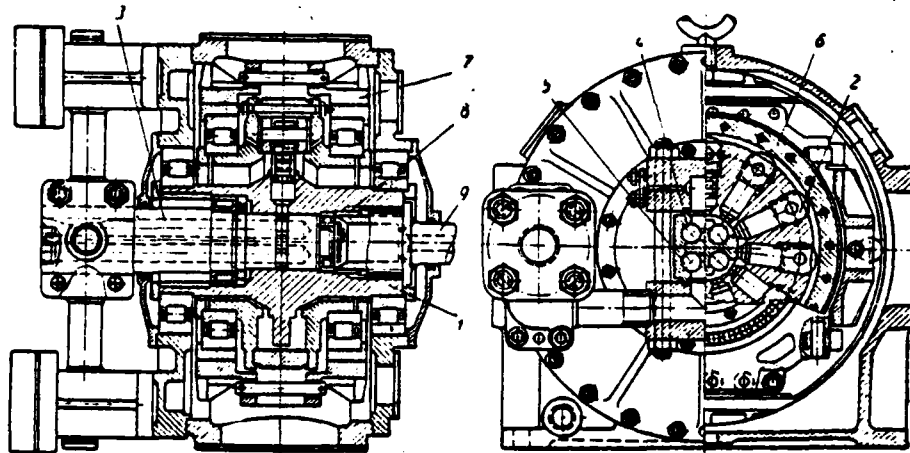

Fig. 267. The construction/design of a rotational-plunger pump with the plungers, which have the constrained motion: 1 - rotor; 2 - plunger; 3 - distributive axis/axle; 4 - valve ports; 5 - plenum channels; 6 - carrier ring; 7 - unit of pump; 8 - key; 9 - drive shaft.

Table 25. Exemplary/approximate characteristics of rotational-plunger pumps.

(1) Производительность при максимальном давлении в л/мин	50	100	200	400	200
(2) Минимальная производительность в л/мин	10	10	20	40	20
(3) Давление в кг/см ²	200	100	75	100	200
(4) Число оборотов в минуту	950	950	950	950	950
(5) Приводная мощность в кВт	21	20,5	28,6	75	100
(6) Объемный к. п. д.	—	0,92	0,95	0,93	0,8
(7) Габариты (длина × ширина × высота) в мм	600 × ×400 × ×616	600 × ×445 × ×670	760 × ×575 × ×860	720 × ×1005 × ×1120	720 × ×1000 × ×1120
(8) Вес в кг	~ 300	~ 300	~ 700	~ 1500	~ 1200

Key: (1). Productivity at a maximum pressure in l/min. (2). Minimum productivity in l/min. (3). Pressure in kg/cm². (4). Number of revolutions per minute. (5). Driving/homing power in kW. (6). Volumetric efficiency. (7). Dimensions (lengths × width × height/altitude) in mm. (8). Weight in kg.

Page 292.

In the powerful/thick pumps for the displacement of unit auxiliary hydraulic cylinders extensively are used.

Fig. 268 shows the schematic of the extended device with the auxiliary hydraulic cylinder and lever control. Oil from booster pump (usually gear-type) comes into the channel of piston 1 and heads for cavity A or B by valve 2. The latter is moved by lever 3, connected with the pedal, or by control lever of press.

The piston of auxiliary cylinder is connected with the unit of pump. With the displacement of valve to the right oil from the pump through the channels in the valve comes into cavity A and moves piston and unit of pump connected with it in the same direction also to the same value. Cavity B in this case through the drilling in the valve is connected with the drain (into pump casing).

With the displacement of valve to the left oil from pump comes into the cavity 5 and moves piston in the opposite direction. Since with the work of pump its unit under the action of the forces, which affect on the plungers, approaches to move the center of rotor, in the housing of the pump there is specified balancing cylinders 4 and 5, whose cavities are connected with the working lines of pump (sucking in and plenum).

Fig. 269 shows the schematic of another device for the control of pump with the aid of the auxiliary hydraulic cylinder.

The displacement of unit is to the right accomplished/realized by auxiliary cylinder 1, controlled by valve 4.

The displacement of unit in the opposite direction is accomplished/realized by another cylinder 2 with the piston of smaller diameter. Cylinder 2 is constantly connected with the delivery line of booster pump. The rotation of valve 4 is accomplished/realized by lever 3. Valve has the helical spindles *a* and also *b*. During the rotation of lever in one direction cylinder 1 and is connected by groove with the plenum line of booster pump through the hole in the piston *b*. in this case the unit of pump is moved to the right until hole *b* leaves the compound with the groove *a*.

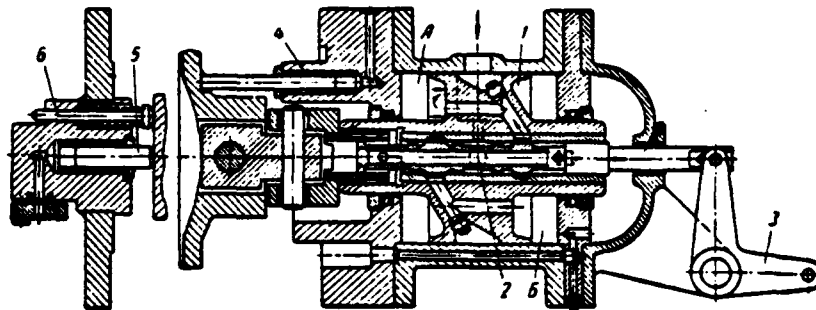

Fig. 268. The diagram of lever control of a rotational-plunger pump:
 1 - piston; 2 - valve; 3 - control lever; 4 and 5 - balancing
 cylinders; 6 - indicator of the eccentricity of pump.

Page 293.

During the rotation of lever in the opposite direction the cylinder through the same hole **B** is connected by groove **B** with the drain, and the unit of pump under the action of cylinder 2 is moved to the left until hole **B** leaves the compound with the groove **B**. Thus, by rotation to the specific angle of lever 3 is assigned the necessary displacement to the unit of pump.

In the neutral position of lever the cavities of pump are connected between themselves by hole 5, and supply by pump ceases even during the inaccurate installation/setting up of the eccentricity of pump to zero.

For the machines with the electrical control the pumps with the control with the aid of electromagnets (Fig. 270) are constructed.

Auxiliary cylinder 5 has two pistons, of which one is intended for the installation/setting up of the unit of pump in the center (zero eccentricity), another - for the displacement of unit to the right.

Cylinder 1 with the piston of smaller diameter is constantly connected with the delivery line of booster pump.

Control of cylinder 5 is accomplished/realized with the aid of valve 10, moving by lever 7, on which electromagnets 8 and 9 act.

Upon the inclusion of electromagnet 8 valve is set in end left position, connecting the chambers/cameras of pistons 2 and 3 with the drain, and the unit of pump under the action of cylinder 1 it is moved to the left.

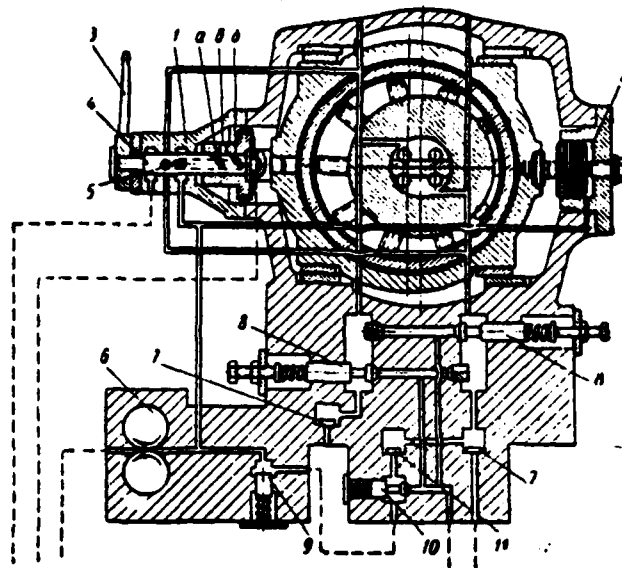

Fig. 269. Diagram of lever control or rotary - plunger pump with revolving valve; 1 and 2 - block displacement cylinders; 3 - control lever; 4 - control valve; 5 - opening which connects operating line of pump; 6 - gear - type pump; 7 - head valve; 8 and 10 - safety valves; 9 - head valve 11 - check valve.

Page 294.

With both de-energized electromagnets valve 10 is set in the mid-position, connecting the chamber/camera of piston 3 with the plenum line of booster pump and the chamber/camera of piston 2 with overflow, and the unit of pump is moved to the central position (zero eccentricity). Piston stroke 3 is limited to nut 6. The chamber/camera of piston 3 is connected with the right end chamber/camera of valve 4 and the left end chamber/camera of valve - with the chamber/camera of piston 2. At a pressure in the chamber/camera of piston 3 valve 4 is driven out to the left, connecting both cavities of pump how is removed the effect of an inaccuracy in the installation/setting up of eccentricity to the zero position. Upon the inclusion/connection of electromagnet 9 valve 10 is moved to the end right position, connecting the chambers/cameras of pistons 2 and 1 with the plenum line of booster pump, valve 4 by spring it is pulled to the right, and the cavity of pump they are disengaged.

In the hydraulic presses the pumps with the automatic feed control on the pressure in the working line received wide acceptance

also.

Fig. 271 shows the schematic of the simplest device, used for an automatic change in the supply in the pressure.

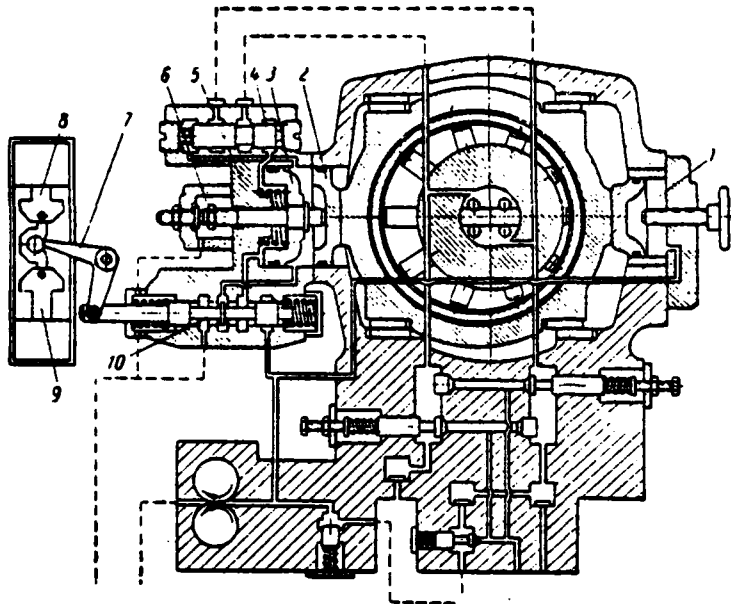

Fig. 270. The diagram of control of rotational-plunger pump with the aid of the electromagnets: 1 - cylinder of the displacement of unit; 2 and 3 - pistons; 4 - valve; 5 - cylinder of the displacement of unit; 6 - nut; 7 - control lever; 8 and 9 - electromagnets; 10 - valve of control.

Page 295.

Spring 1, placed in pump casing, acts on runner, moving it to the left to the detent into screw/propeller 2, with the aid of which the maximum supply of pump is set. From left side of pump in its housing is an auxiliary cylinder 3, connected with the working line. The plunger of cylinder abut against the unit of pump and is created

the effort/force, opposite to the direction of spring effect. Until the effort/force, created by auxiliary cylinder, exceeds the effort/force of the pretightening of spring, the supply of pump remains the constant, established/installed with the aid of screw/propeller 2.

With further pressure rise in the working line the plunger overcomes the effort/force of spring and moves the unit of pump to the right, in consequence of which the supply by pump is decreased.

In the extreme right position of unit the pump develops maximum pressure and minimum supply. If necessary of maintaining the maximum effort/force on the slider of press in its positive seat (for example, during the extrusion/pressing of plastics or the extrusion/pressing by rubber - at the end of the extrusion/pressing) minimum supply is set for the compensation of leaks/leakages from the hydraulic system.

The dependence of the supply of pump and its hydraulic power on the pressure is shown on Fig. 272 in the form of the curves W - for the supply and N - for the power, that correspond to the work of pump with the springs of different characteristics.

As can be seen from diagram, the supply of pump lags by constant

and maximum to specific pressure p_n , which corresponds to the pretightening of spring. To this value of pressure the power grows/rises according to the law of straight line. With further pressure rise the supply of pump begins to fall according to the law of straight line, whose inclination/slope depends on the characteristic of spring.

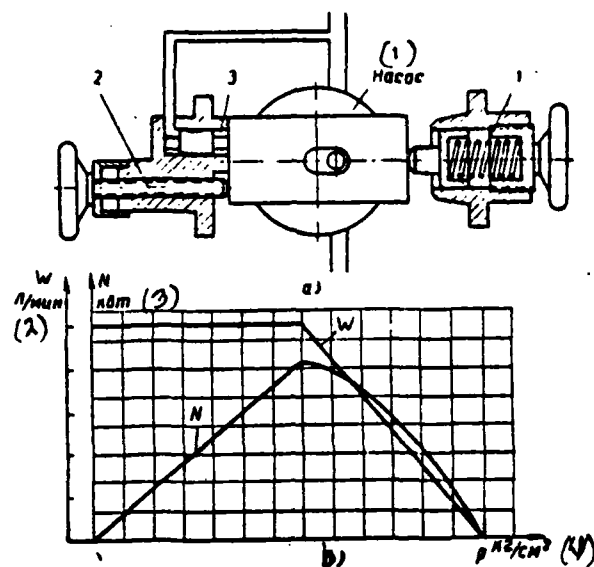

Fig. 271. The schematic diagram of the automatic feed control of rotational-plunger pump on the pressure in the hydraulic system: 1 - spring; 2 - screw/propeller; 3 - cylinder of the displacement of unit; a) the schematic of pump; b) fundamental pump performance.

Key: (1). Pump. (2). l/min. (3). kW. (4). kg/cm².

Page 296.

Lifting power from this point on, is determined by the product

$$N = \kappa \cdot W \cdot p,$$

where W in l/min and by p in kg/cm² - instantaneous variable/alternating/variable values;

k - scaling factor, depending on dimensionality.

If W - in l/min, p - in kg/cm², N - in kW, then

$$\kappa = \frac{1}{612}.$$

For the best use of power of engine in the case of low required pressure in the first period of stroke of press pressure/clamping device with two consecutively/serially effective springs (Fig. 273) frequently is applied.

Fig. 274 shows the schematic of the device, used for the powerful/thick pumps, in principle similar to that shown in Fig. 271, in which auxiliary cylinder 1 and spring 2 act on the unit of pump not directly, but through the follower (see Fig. 268), whose work is described earlier.

The low use of power of engine with the work of pump with the high pressure is a shortcoming in the described devices for an automatic change in the supply in the pressure in the system. If supply by pump at a maximum pressure is equal to zero (see Fig. 271), then the equation of the straight line, which characterizes supply in the function of pressure from the moment/torque of the beginning of a change in the supply, will take the form

$$W = W_{\max} \left(\frac{p_{\max} - p}{p_{\max} - p_n} \right),$$

where p_n - pressure, which corresponds to the beginning of a change in the supply.

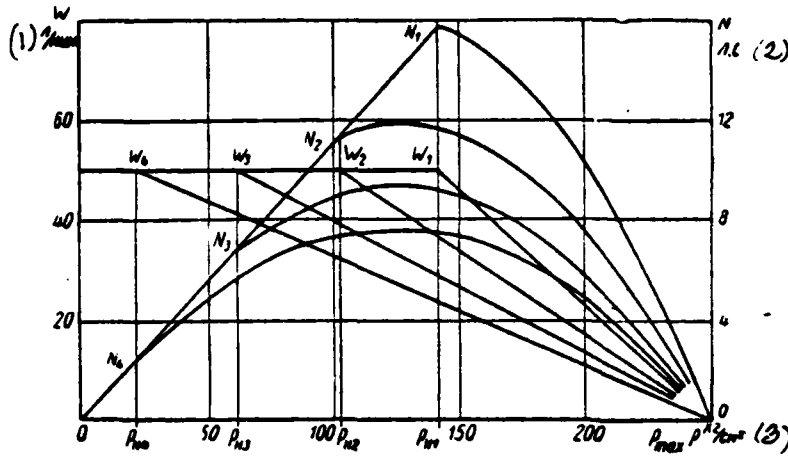

Fig. 272. Performance diagrams of rotational-plujernogo pump with the automatic feed control on the pressure in the hydraulic system.

Key: (1). l/min . (2). hp . (3). kg/cm^2 .

Page 297.

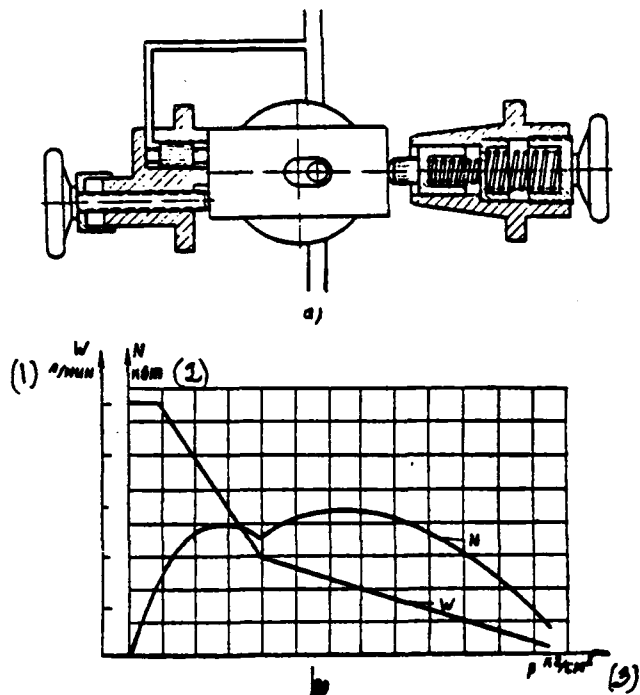

Fig. 273. Schematic diagram of the automatic feed control of rotational-plunger pump on the pressure in the hydraulic system: a) the schematic of pump; b) fundamental pump performance.

Key: (1). 1/min. (2). kW. (3). kg/cm².

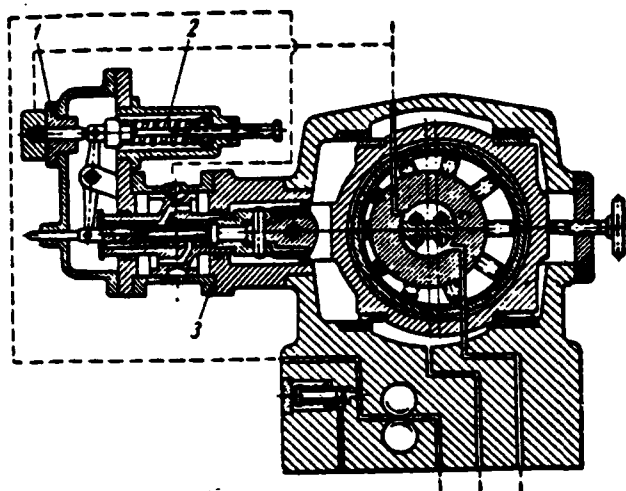

Fig. 274. The schematic diagram of the automatic feed control of powerful/thick rotational plunger pump on the pressure in the hydraulic system: 1 - cylinder; 2 - spring; 3 - hydraulic cylinder of the displacement of the unit of pump.

Page 298.

Respectively expression for the power, developed with pump in the section from p_N to p_{max} , will be written in the form

$$N = \kappa \cdot W_{max} \left(\frac{p_{max} p - p^2}{p_{max} - p_N} \right).$$

From the obtained expression it is possible to see that the maximum power coefficient corresponds to the pressure, equal to half of maximum, i.e., $p_{Nmax} = \frac{p_{max}}{2}$.

With the work of pump with the supply is less than the maximum

and at the pressure, greater than $p_{N_{max}}$, the power of engine is utilized incompletely.

In many instances, when press is intended for the specific technological process with the known graph of loads on the way of the crosshead, the load sharply growing/rising at the end of the working stroke, it is expedient to use an automatic change of supplying the pump in the dependence on the pressure in the system with the aid of the mechanism, which would provide the constancy of the power, developed with engine. For this it is necessary that the supply of pump depending on pressure would change according to the law

$$W = \frac{1}{\kappa} \cdot \frac{N}{p}.$$

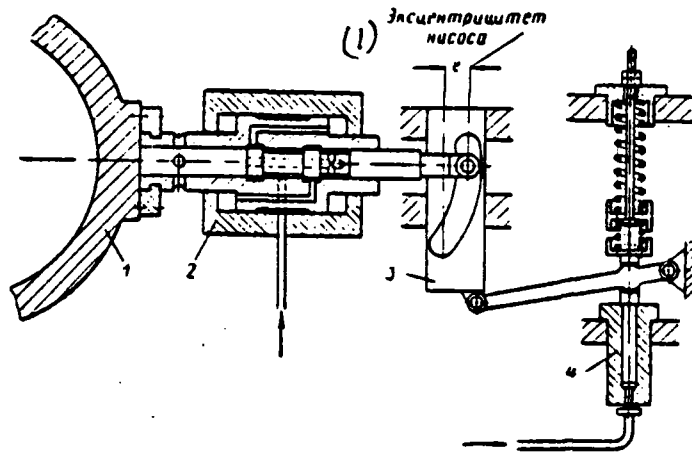

Fig. 275. The schematic diagram of automatic control of rotational-plunger pump of the constant power: 1- pump; 2 - servomotor; 3 - cam; 4 - auxiliary cylinder.

Key: (1). Eccentricity of pump.

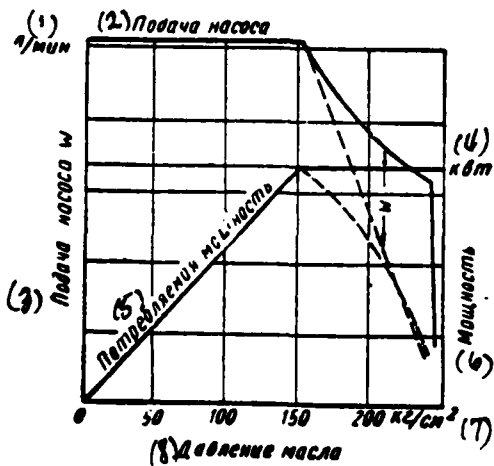

Fig. 276. Performance diagrams of rotational-plunger pump of constant power.

Key: (1). l/min. (2). Supply of pump. (3). Feed of pump W. (4). kW.
(5). Required power. (6). Power. (7). kg/cm². (8). Oil pressure.

Page 299.

This dependence can be obtained by the use/application of the cam gear, whose schematic is shown in Fig. 275. It is possible to obtain the pump performance, shown in Fig. 276, by the appropriate forming of cam.

On the diagram Fig. 276 ordinates designated the additional supply of pump at different pressures in the system, which the pump gives, if we use system on the diagram Fig. 275 instead of that shown in Fig. 271.

ROTATIONAL-PLUNGER PUMPS WITH AXIAL ARRANGEMENT OF PLUNGERS.

Rotational-plunger pumps with the axial arrangement of plungers (along the drive shaft) are constructed to the high pressures and the large supplies and have many structural/design varieties. The extended construction/design of this pump is shown in Fig. 277.

The displacement of plungers 1 in this pump is accomplished/realized as a result of the arrangement of cylinder

DOC = 83120714

PAGE

607

block 2 at angle to drive shaft 3. Cylinder block obtains rotation from the drive shaft through cardan shaft 4.

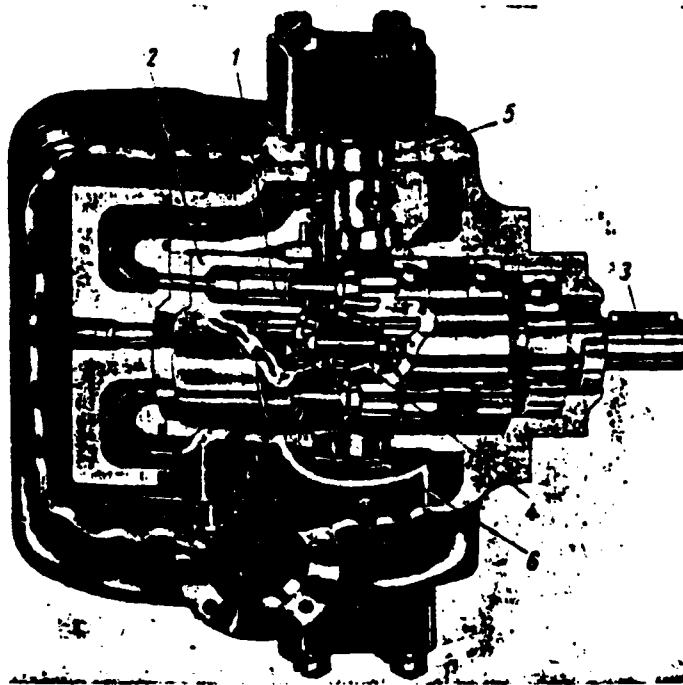

Fig. 277. Construction/design of rotational-plunger axial pump of variable/alternating/variable supply.

[Page 300] A change of supplying the pump is accomplished/realized by a change in the angle of the slope of cylinder block with respect to the drive shaft, which is accomplished/realized either by hand with the aid of the worm or gear mesh or by a hydraulic cylinder, and in this case a change of supplying the pump can be accomplished/realized automatically on the pressure in the hydraulic system. Pump does not have suction and plenum values, supply and branch/removal of oil in it are performed through the windows, drilled in pins/journals 5 and 6.

The basic parameters of such pumps are given in Table 26.

Other constructions/designs of pumps are shown in Figs. 278 and 279.

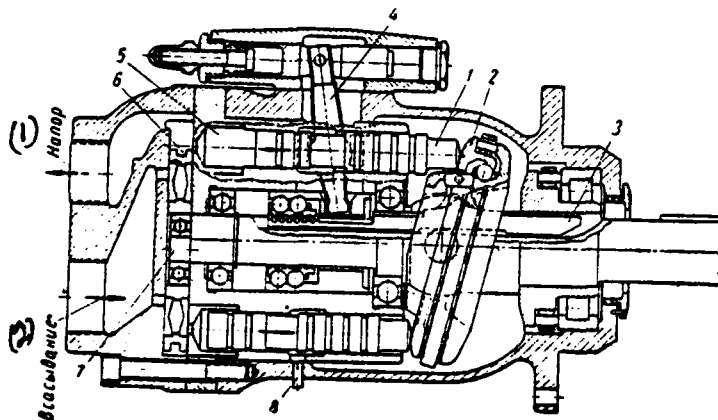

Fig. 278. Rotational-plunger axial pump of the variable/alternating/variable supply: 1 - plunger; 2 - supporting/reference rocking plate/slab; 3 - mobile key; 4 - lever of the control/check of the supply of pump; 5 - cylinder block; 6 - flat/plane distribution valve; 7 - cam of slide valve; 8 - attachment/connection to the pump of fine feed, that accomplishes/realizes backward motion of plungers.

Key: (1). Pressure. (2). Suction.

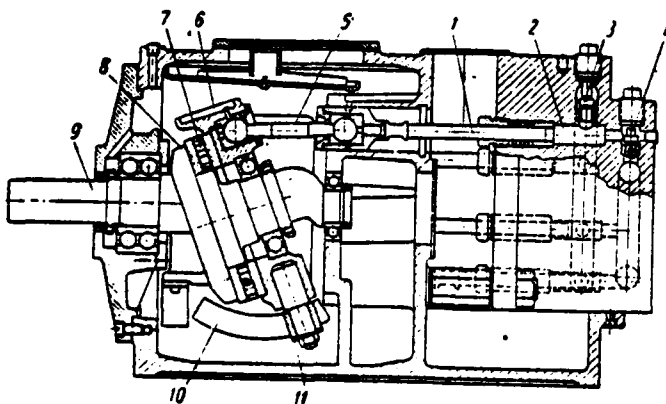

Fig. 279.

Fig. 279. Rotational-plunger axial pump of the constant supply: 1 - plunger; 2 - cylinder block; 3 - delivery valve; 4 - intake valve; 5 - connecting rod; 6 - base plate; 7 - supporting/reference roller bearing; 8 - supporting/reference shaft flange; 9 - drive shaft; 10 - guiding; 11 - slider of base plate.

Page 301.

Table 26. Basic parameters of rotational-plunger axial pumps to the pressure to 200 kg/cm² (firm Vikser, USA).

(1) Число оборотов в минуту	(2) Наибольшая подача в л/мин	(3) Наибольшая кратковременная мощность в кВт	① Число оборотов в минуту	② Наибольшая подача в л/мин	③ Наибольшая кратковременная мощность в кВт
1200	106	37	600	1510	514
1200	212	73.5	514	1890	661
1200	424	147	514	2840	955
900	644	220	450	4920	1690
720	760	257	400	8700	2940
600	870	294			

Key: (1). Number of revolutions per minute. (2). Greatest supply in l/min. (3). Greatest short-time rating in kW.

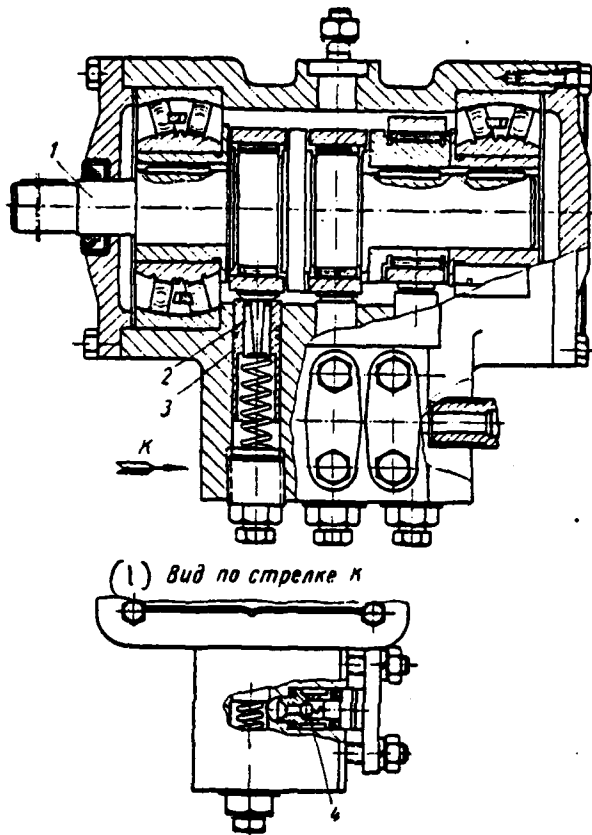

Fig. 280. Plunger eccentric pump: 1 - eccentric shaft; 2 - intake valve; 3 - plunger; 4 - delivery valve.

Key: (1). Form on arrow/pointer K.

Page 302.

PLUNGER ECCENTRIC PUMPS.

For the relatively small supplies won acceptance high-speed plunger eccentric pumps, which work on mineral oil. One of the

constructions/designs is shown in Fig. 280, and pump performance are given in Table 27.

The arrangement/position of intake valve 2 in hollow plunger 3 is design feature; with the forcing of oil the valve is moved together with the plunger.

Pump casing serves as reservoir for oil. The pumps of this construction/design successfully work on oil, which has viscosity/ductility/toughness of 3-5° according to Engler.

Table 27. Characteristics of plunger eccentric pumps.

(1) Параметры	(2) Марка насоса		
	Г-17-22А	Г-17-32	Г-17-33
(3) Максимальная подача в л	5	18	35
(4) Наибольшее давление в кг/см ²	200	300	300
(5) Потребляемая мощность в кВт	2,8	11,5	23,5
(6) Число оборотов вала в минуту	1500	1500	1500
(7) Объемный к. п. д.	0,75	0,9	0,9
(8) Эффективный к. п. д.	0,58	0,73	0,76
(9) Напор на всасывании в м	(10) От 0,5 до 1		
(11) Вес насоса в кг	13,5	42,9	45,6

Key: (1). Parameters. (2). Brand/mark of pump. (3). Maximum supply in l. (4). Greatest pressure in kg/cm². (5). Required power in kW. (6). Number of revolutions of shaft per minute. (7). Volumetric efficiency. (8). Effective efficiency. (9). Pressure during the suction m. (10). From 0.5 to 1. (11). Weight of pump in kg.

Page 303.

Chapter 6.

PUMP-AND-BATTERY STATIONS.

General information.

Pump-and-battery stations are intended for supply of presses with high-pressure liquid and consist of the storage battery/accumulator of liquid, pumps, devices of control, conduit/manifold and fittings.

Storage battery/accumulator stores high-pressure liquid during the pauses in the work of presses and in the periods of the lowered/reduced fluid flow rate and are loosened it at the moments/torques, when the consumption of liquid exceeds supply by pumps.

Early constructions/designs of storage batteries/accumulators they had very simple device and were made with the cylinders and the plungers. As the load in them (Figs 281 and 282) for high-pressure creation of liquid was applied the load (scrap of cast iron or

concrete) or the compressed air by pressure to 70 atm. (Fig. 283). Control of such storage batteries/accumulators very uncomplicatedly and is reduced to opening or closing of the idling valve of pump.

Their unwieldiness (high altitude, large loads on the foundation) is a shortcoming in these storage batteries/accumulators.

As a result of the presence in the cargo storage batteries/accumulators of the large moving/driving masses, during the abrupt deceleration of fluid flow, which goes from the storage battery/accumulator, appear the hydraulic impacts. The velocity of dropping plunger in such storage batteries/accumulators does not exceed 0.5 m/s at the operating speed of press, equal to approximately 100 mm/s.

Contemporary storage batteries/accumulators are constructed with the direct effect of air on the liquid (Figs 284 and 285). Representation about the overall dimensions of this storage battery/accumulator in the comparison with the overall dimensions of load storage battery/accumulator gives Fig. 286.

For the battery charging the compressor is set by compressed air at the station.

Storage batteries/accumulators are applied both for the unit ones and for the group press installations/settings up and are constructed with the pressure to 320 kg/cm². To the large pressures the storage batteries/accumulators are constructed rarely, since in this case it is difficult to ensure the density of hydraulic system, which is constantly located under the pressure.

Page 304.

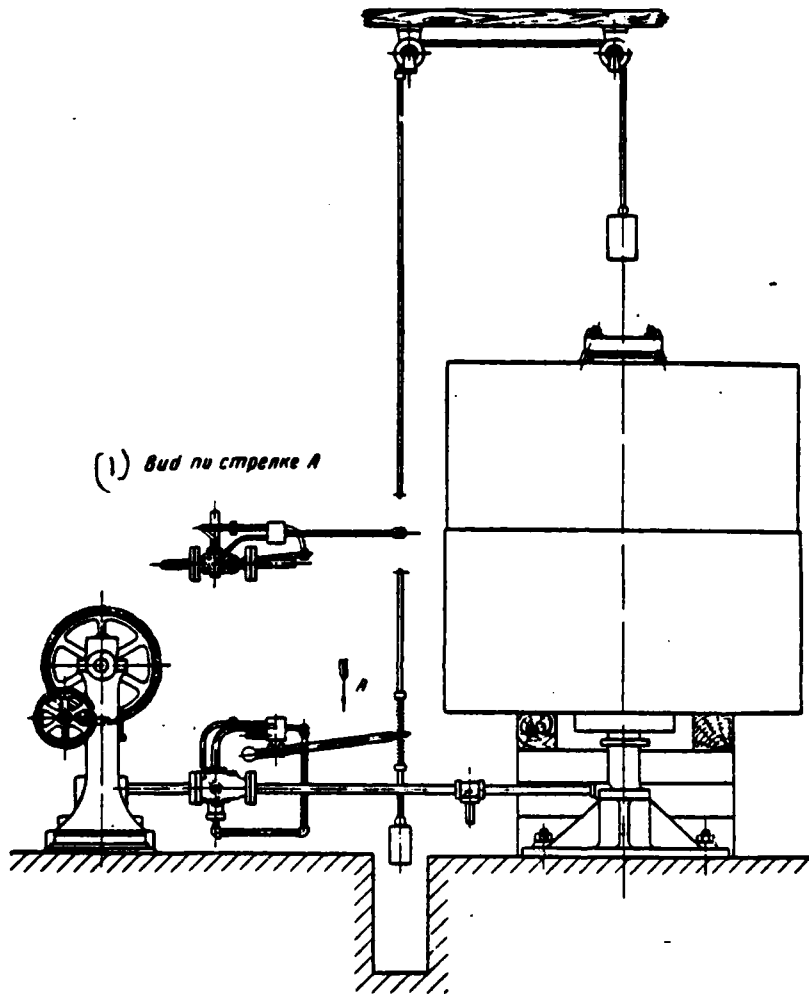

Fig. 281. Schematic of cargo storage battery/accumulator.

Key: (1). Form on arrow/pointer A.

Page 305.

In pumping-accumulator stations plunger crank pumps and relatively rarely multistage centrifugal are applied mainly. The use/application of the latter has the advantage that their dimensions are less; the maximum pressure, developed by them, completely definitely, which excludes the possibility of the overloading of storage battery/accumulator; the checking of the upper level of liquid in the storage battery/accumulator in this case is not required.

Their low efficiency is a shortcoming in the use/application of centrifugal pumps. The level of liquid in the storage battery/accumulator fluctuates between the upper maximum, on which all pumps run idle, and by the lower maximum level, at which the fluid flow rate from the storage battery/accumulator ceases. The volume of the working fluid, included between these levels, composes worker, or maneuvering, volume.

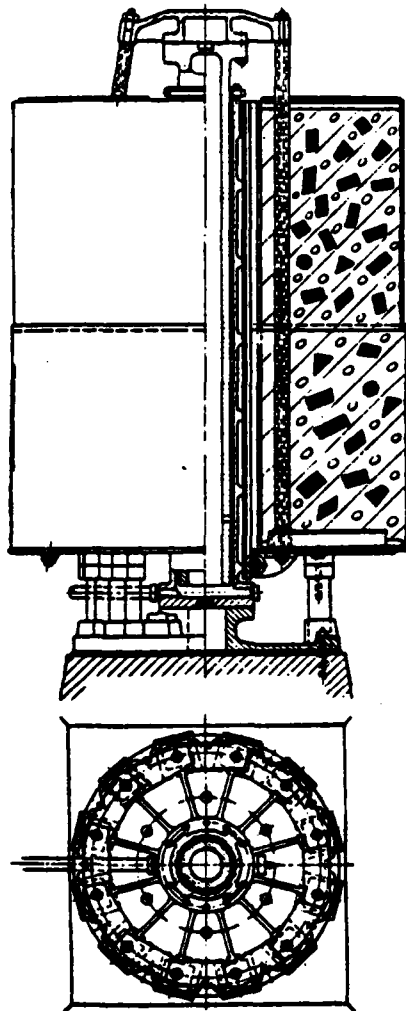

Fig. 282.

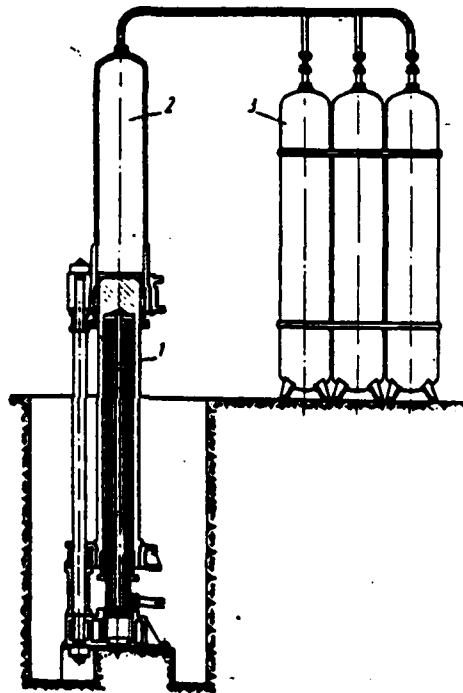

Fig. 283.

Fig. 282. Construction/design of cargo storage battery/accumulator.

Fig. 283. The schematic of plunger storage battery/accumulator with the pneumatic load: 1 - hydraulic cylinder; 2 - air cylinder; 3 - compressed air tanks.

Page 306.

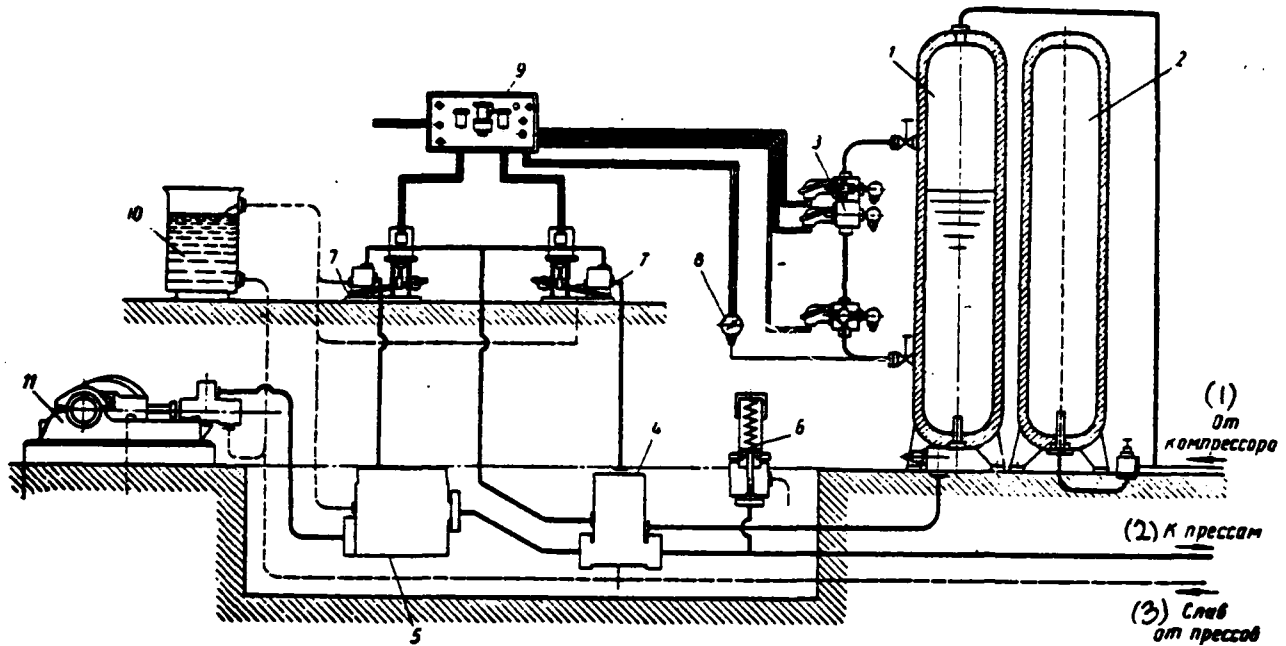

Fig. 284. The schematic diagram of pumping plant with the pneumatic storage battery/accumulator: 1 - water bottle; 2 - compressed air tank; 3 - apparatuses of the checking of the level of liquid; 4 - automatic check valve of minimum level; 5 - idling valve of pump; 6 - safety valve; 7 - auxiliary valve distributors; 8 - manometer; 9 - control panel; 10 - the pressure tank of pump; 11 - pump.

Key: (1). From the compressor. (2). To the presses. (3). Drain from the presses.

623

Page
307.
A

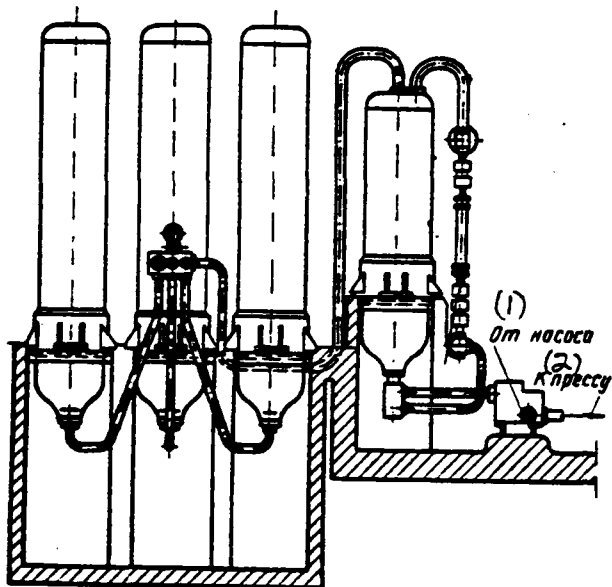

Fig. 385.

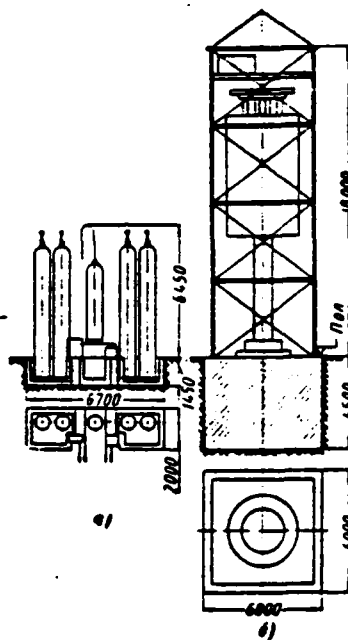

Fig. 286.

Fig. 285. Exemplary/approximate construction/design of pneumo-hydraulic storage battery/accumulator.

Key: (1). From the pump. (2). To the press.

Fig. 286. Comparison of the dimensions of the cargo and pneumatic storage batteries/accumulators with a capacity/capacitance of 1000 l with the pressure 200 kg/cm²: a) the pneumatic storage battery/accumulator with a weight of 30 t; b) the cargo storage battery/accumulator with a weight of 370 t.

Page 308.

For the conversion of pumps into the no-load operation into the moment/torque of full-stroke admission of storage battery/accumulator it is necessary either to set idling valves or to have a hoisting device of the intake valves of pumps.

For warning/preventing the complete emptying of storage battery/accumulator in the conduit/manifold, which goes to the presses, the automatically closing valve (valve of minimum level) is set.

Valve control is accomplished/realized with the aid of the apparatuses, which check the assigned levels of liquid in the storage battery/accumulator.

SUPPLY BY PUMPS AND THE WORKING VOLUME OF LIQUID IN THE STORAGE BATTERY/ACCUMULATOR.

The total supply of the pumps, adjusted on the station, must be equal to the sum of averages in the cycle of fluid flow rates by the presses, fed by the station:

$$W_n = \sum_{i=1}^{i=k} \frac{Q_i}{t_i \eta_0} \cdot 60 \text{ l/min}, \quad (274)$$

where Q_i - fluid flow rate by press per cycle of its work in l;

t_i - duration of one cycle of the work of press per second;

k - number of presses, fed by the pump-and-battery station;

η_0 - volumetric efficiency of hydraulic system.

During the determination of the amount of liquid consumed by press it is necessary to consider its compressibility.

The additional amount of liquid of high-pressure, which must be fed to the press, is equal to

$$\Delta Q'_n = Q'_n \frac{p_u - p_n}{E}, \quad (275)$$

where Q'_n - volume of liquid in the hydraulic system of press, pressure by which must be increased up to a pressure of storage battery/accumulator;

$p_u - p_n$ - pressure difference in the storage battery/accumulator and in the filler tank in kg/cm²;

E - modulus of elasticity of liquid; $E \approx 2 \cdot 10^4$ kg/cm².

The determination of the working volume of liquid in the storage battery/accumulator is most simply produced by the grapho-analytic method.

Let the graphs of fluid flow rate be prescribed/assigned by presses (Fig. 287). On these graphs is constructed the combined graph of flow rate by all presses for time t_{\max} (Fig. 288). Is further constructed the combined graph of fluid flow rate by presses at each moment of time and graph of the amount of liquid, subject by pumps (Fig. 289), on which is defined the necessary working volume of liquid in storage battery/accumulator Q_n , as the difference between the consumption of liquid by presses and by the supply of pumps.

On given graphs the fluid flow rates by presses in the various periods of their work were received as constants. In actuality these flow rates, as a rule, are variables. Rate of discharge set aside on the graphs is calculated as average/mean during this operating cycle of press (on the average speed).

627

Page 309.

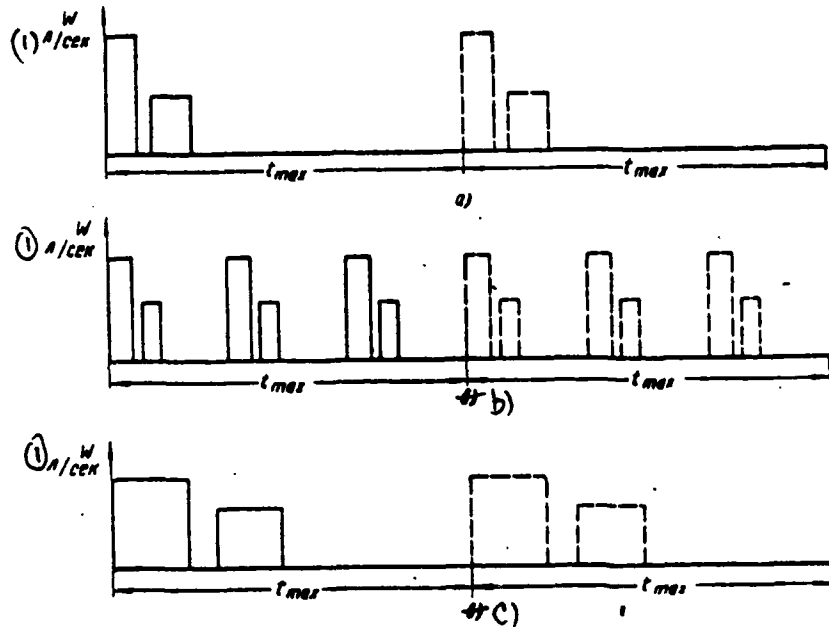

Fig. 287. Graphs of fluid flow rate by the presses: a) the 1st press; b) the 2nd press; c) the 3rd press.

Key: (1). 1/s.

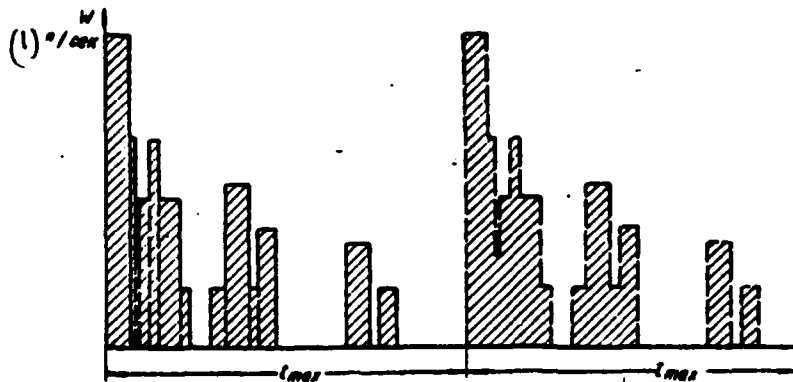

Fig. 288. Combined graph of fluid flow rate by presses.

Key: (1). 1/s.

Page 310.

For guaranteeing the uninterrupted feeding of presses and possibility to in proper time perform the repair of pumps without the stop of entire station is provided for, as a rule, one emergency pump.

The number of pumps adjustable on the station is equal

$$\frac{W_n}{w_n} + 1,$$

where w_n - supply by one pump in 1/min.

In order not to have large standby lifting power, usually in the stations they set not less than three working pumps. The total supply of pumps and a quantity of pumps must be refined after the selection of the sizes/dimensions of the water bottle of storage battery/accumulator and setting of the levels of inclusion/connection and disconnection of each pump, i.e., setting the duration of the work of each pump in the calculated cycle of the work of storage battery/accumulator. During the practical calculations, taking into account different duration of the work of pumps, quotient of the division $\frac{W_n}{w_n}$ they round to a whole larger number.

During the construction of the combined graph of fluid flow rate by presses, with a small quantity of presses (3-4), they accept, that the beginning of the work of presses coincides. When the real frequency of agreements is sufficiently great, this approach to the solution of assigned mission does not cause doubts. With a large quantity of presses probability and the frequency of such agreements is small and is expressed by the portions of the percentage of operating time.

Is given below the calculation method, developed by Prof. I. L. Perlin [24], who makes it possible to avoid the overestimate of the capacity/capacitance of storage battery/accumulator ¹.

FOOTNOTE ¹. The subsequent part about the calculation of the capacity/capacitance of storage battery/accumulator (to the section the "sizes/dimensions of water accumulator") is written by Prof. I. L. Perlin. ENDFOOTNOTE.

The essence of this method consists in the fact that the combined graph of the flow rate of water is constructed not for all presses of installation/setting up, but only for those most powerful/thickest of the number established/installed and for those, in which the maximum selection of water frequently coincides.

630

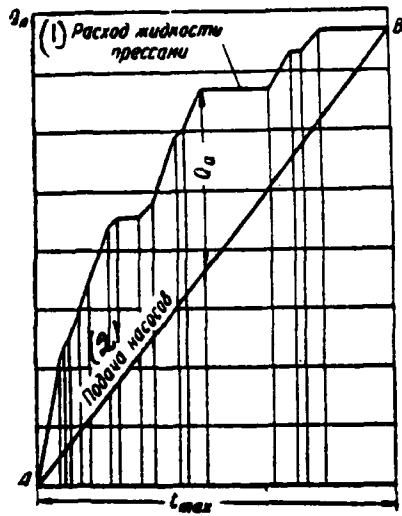

Fig. 289. Combined graph of liquid by presses and graph of liquid feed by pumps.

Key: (1). Liquid flow by presses; (2). Feed of pumps.

For setting of the value of the total selection of water by presses and frequency of the agreement of their maximum selections are utilized two basic condition/positions of the probability theory: a) the theorem of total probability and b) the theorem of compound probability. The first theorem is formulated as follows: "Probability that will occur either the event A or event B, it is equal to the sum of their probabilities", i.e.

$$\text{Prob. } \{ \text{either A or B} \} = \text{Prob. (A)} + \text{Prob. (B)}. \quad (276).$$

Events A and B are assumed to be incompatible.

The second theorem is formulated as follows: "Probability A and event B (i.e. simultaneously will occur both event A and event B), will occur it is equal to the product of their probabilities", i.e.

$$\text{Prob. } \{ \text{and A and B} \} = \text{Prob. (A)} \times \text{Prob. (B)}. \quad (277).$$

Proof of both theorems can be found in any management/manual on the probability theory.

In connection with the question in question the theorem of compound probability can be illustrated by the following example.

Let there be two presses with the durations of the selection of

water during the cycle with respect in t_1 and t_2 s., also, with durations of the complete cycles in T_1 and T_2 s. In this case:

probability that at any moment the selection of water is accomplished/realized by the first press, it will be

$$\omega_1 = \frac{t_1}{T_1}; \quad (278)$$

Probability that at any moment the selection of water is accomplished/realized by second press, will be

$$\omega_2 = \frac{t_2}{T_2}. \quad (279)$$

According to the theorem of compound probability, probability that at any moment the selection of water is accomplished/realized by both presses, will be

$$\omega_1 \omega_2 = \frac{t_1}{T_1} \cdot \frac{t_2}{T_2}. \quad (280)$$

Respectively with a larger quantity of presses (M) probability that at any moment the selection of water is accomplished/realized by all presses, will be

$$\omega = \omega_1 \cdot \omega_2 \cdot \omega_3 \cdot \dots \cdot \omega_M. \quad (281)$$

We now solve the following problem: in the shop are established/installed and work M identical presses with the duration of selection water t s. and the duration of the cycle of each T s. it is necessary to determine the portion of the time (or, which is the same, probability), during which the selection of water does not occur at all either it occurs only one or only two or three and so forth by presses, i.e., in the general case it is necessary to

determine the probability of the realization of the simultaneous selection of water K with a quantity of presses from M working (ω_M^K). They solve assigned mission with the aid of the following considerations.

Page 312.

Probability that at any moment this press accomplishes/realizes selection of water, will be

$$\omega_i = \frac{t}{T} = p. \quad (282)$$

Probability that at any moment this press does not accomplish/realize selection of water, will be

$$1 - \omega_i = 1 - p. \quad (283)$$

Probability that at any moment K of presses they select/take water, will be (according to the theorem of multiplication)

$$\omega_M^K = \underbrace{p \times p \times p \dots p}_K = p^K. \quad (284)$$

Probability that none of the remaining (M-K) presses at any moment selects/takes water, will be $(1-p)^{(M-K)}$.

Probability that at any moment from M of the working presses K they select/take water, and by rest (M-K) they do not select/take water, it will be, obviously,

$$p^K \cdot (1-p)^{(M-K)}. \quad (285)$$

For solving assigned mission it is unimportant, what precisely K

of presses from the workers M at the given moment/torque select/take water and what (M-K) they do not select/take. For example, if are established/installed 10 presses and we search for the probability of the simultaneous selection of water six by presses, then for obtaining the correct response/answer one should consider that water they can select/take presses in the different groupings. Thus, they select/take water of the press of the 1st, the 2nd, the 3rd, the 4th, the 5th and the 6th, and rest - from the 7th to the 10th - do not select/take, either they select/take water of the press of the 2nd, the 3rd, the 4th, the 5th, the 6th and the 7th, and the rest of the eighth, the 9th, the 10th and the 1st do not select/take, or they select/take water of the press of the 3rd, the 4th, the 5th, the 6th, the 7th and the eighth, and the rest of the 9th, the 10th, the 1st and the 2nd do not select/take and so forth. It is obvious that such groupings we will have in this case as much, as ones will contain a number of combinations of 10 on 6 (or of 10 on 4), or in the general case a number of such groupings will be determined by a number of combinations of M on K, i.e.

$$C_M^K = C_M^{(M-K)} = \frac{M!}{K!(M-K)!} \quad (286)$$

Taking into account that presented and applying the theorem of total probability, we obtain overall probability that at any moment any K presses from M working they simultaneously select/take water, and the rest M-K water do not select/take, then it will be

$$\omega_M^K = C_M^K p^K (1-p)^{(M-K)}. \quad (287)$$

Page 313.

Let us note that on Newton's binomial

$$\sum_{K=0}^{K=M} C_M^K \rho^K (1-\rho)^{M-K} = (\rho + 1 - \rho)^M = 1, \quad (288)$$

i.e. the sum of all portions of time, during which is accomplished/realized the selection of water 0, 1, 2, 3, 4 ... M by presses, is equal to one or 100%, which is completely logical, since otherwise it cannot be.

Let us determine according to formula (287) probability of the joint selection of water by three presses of five workers with $t=10$ s. and $T=130$ s.:

$$\begin{aligned} \omega_5^3 &= C_5^3 \left(\frac{1}{13}\right)^3 \left(\frac{12}{13}\right)^{5-3} = \\ &= \frac{1440}{371000} \approx 0,4\%. \end{aligned}$$

i.e. in 100 working hours three presses will select/take simultaneously water during 24 min. Since the duration of the selection of water per cycle is 10 s., the maximally possible number of complete agreements in the work of presses, i.e., when coincides both the time of beginning and the time of the termination of the selection of water, it will be $24 \cdot 60 / 10 = 144$. For the same case Fig. 290 gives the graph of these probabilities, and below complete calculation of probabilities for $K=0, 1, 2, 3, 4,$ and 5 presses, determined according to formula (287):

$$\omega_5^K = C_5^K \left(\frac{1}{13}\right)^K \left(\frac{12}{13}\right)^{5-K} = C_5^K \left(\frac{1}{13}\right)^K \cdot 12^{5-K}. \quad (289)$$

636

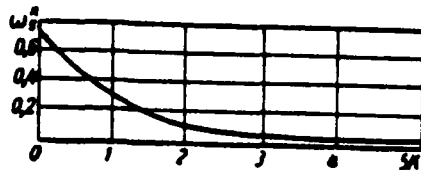

Fig. 290. Table and the graph of the probabilities of joint selection five by presses, which have $t=10$ s. and $T=130$ s.

K	0	1	2	3	4	5
C_5^K	1	5	10	10	5	1
$12^5 - K$	249 000	20 700	1 730	144	12	1
$C_5^K \cdot 12^5 - K$	249 000	103 700	17 280	1 440	60	1
$\omega_5^K^{(1)}$ в %	67	28	4,6	0,4	0,15	0,003
(2) Время совместной работы прессов за 100 рабочих часов в сек.	67·3600	28·3600	4,6·3600	0,4·3600	0,15·3600	0,003·3600
(3) Максимально-возможное количество полных сопадений на 100 рабочих часов	24 000	9 700	1650	144	50	1

Key: (1). in. (2). Time of the joint operation of presses in 100 working hours in s. (3). Most feasible number of complete agreements for 100 working hours.

Page 314.

On the basis of that presented, it is not difficult to solve the problem also in the more general view, i.e., when several presses with the different durations of the selection of water and cycles of work work.

Let us assume that there work M presses with the durations of the selection of water $t_1, t_2, t_3, \dots, t_M$ s. and by durations of the cycles of work $T_1, T_2, T_3, \dots, T_M$ s. Probability that at any moment the first press will select/take water, will be expressed by ratio $t_1/T_1=p_1$. Corresponding probabilities for the remaining presses will be expressed by values

$$\frac{t_2}{T_2} = p_2; \frac{t_3}{T_3} = p_3; \dots; \frac{t_M}{T_M} = p_M.$$

After selecting any group of presses, it is possible to determine the probability of the simultaneous selection of water by this group. For example, probability that at any moment the group of presses (the 2nd, the 3rd and the 5th) will simultaneously select/take water will be expressed by the product

faiths/beliefs.

and 5) = $\rho_2 \cdot \rho_3 \cdot \rho_6$.

(290)

After calculating, thus, probabilities for all possible combinations of presses, let us find that for some groups the probability of their joint selection of water will be expressed by ones and even tens of percent, and for some combinations - tenth, hundredth and with even smaller portions of percentage.

It is natural that the projected/designed or checked by calculation storage battery/accumulator must provide such combinations with water.

The probability of the joint selection of water is so great that the lack of high-pressure water at the moments of agreement can have a noticeable effect on production results.

It is possible to assume that all combinations of presses with the probability in 1% and more must be provided by water completely.

Certainly, this boundary index can have another value, which depends exclusively on specific conditions. The calculation of probabilities for all possible combinations of presses, especially with their large quantity (for example, 7 and more), is complicated by considerable technical difficulties.

These difficulties can be avoided as follows: let us number all established/installed or designed to the installation presses that so that the numbers of presses, beginning from the first, would increase in proportion to the decrease of the volumes of working pressure cylinders. Then we determine the probability of the joint selection of water by first three, then first four, then first five and so forth by presses. The obtained probabilities will be decreased. After obtaining the first probability less it is previously the boundary index (for example, 1%) accepted, we cease further determination of probabilities. Obtained thus first combination of presses with the probability of the simultaneous selection of the water smaller than the boundary index, can be considered that water absorbing group of presses, of which should be calculated the working volume of storage battery/accumulator.

Page 315.

Actually/really, all remaining combinations of presses during the simultaneous selection of water will have either smaller water-retaining capacity or their simultaneous selection of water will have a probability less water-retaining capacity, or their simultaneous selection of water will have a probability smaller than

the boundary index.

After establishing this water absorbing group of presses, we determine working volume necessary only for this group of the liquid of storage battery/accumulator, by graphic method indicated earlier.

For an example let us calculate the working capacity/capacitance of the storage battery/accumulator servicing eight bar-tube presses:

with the effort/force 3500 t ... of 1 pcs.

with the effort/force 1500 t ... of 1 pcs.

with the effort/force 600 t ... of 3 pcs.

with the effort/force 300 t ... of 3 pcs.

Of the durations of the molding cycles and selection of water by each press, accepted according to P. S. Istomin [11], we bring in Table 28.

We determine the probabilities of the joint consumption of water for the gradually increasing quantity of presses.

The probability of joint selection by two presses - by effort/force 3500 and 1500 t, since in the entire installation there is only one such press, obviously, will be expressed by the product

$$\text{faiths/beliefs. } (l_{3500} + l_{1500}) = p_{3500} \cdot p_{1500} = 0,21 \cdot 0,2 = 0,042.$$

The probability of joint selection by three presses - one by effort/force 3500 t, one by effort/force 1500 t and one by effort/force 500 t, of three that established/installed, will be expressed by the product

$$\text{faiths/beliefs. } (l_{3500} + l_{1500} + l_{500}) = p_{3500} \cdot p_{1500} \cdot \theta'_{(500).3}$$

Here $\theta'_{(500).3}$ is the probability, with which at any moment will select/take water at least one of the established/installed three presses with the effort/force on 500 t or, in other words, probability that at the given moment/torque select/take water the first, the second and the third of the presses in question and is eliminated only the probability of the time, with which the presses do not together select/take water.

Table 28. The summary table of the duration of the cycles of work and selection of water by the presses of installation (Fig. 291).

(1) Усилия прессы в т	(2) Длительность цикла прессования в сек.	(3) Длительность отбора воды за один цикл в сек.	(4) Вероятность отбора воды в любой момент
3500	161.4	34.2	$p_{3500} = 0.21$
1500	130.1	26.5	$p_{1500} = 0.20$
600	45	6	$p_{600} = 0.134$
300	30	5	$p_{300} = 0.165$

Key: (1). Effort/force of press in t. (2). Duration of molding cycle in s. (3). Duration of the selection of water per cycle in s. (4). Probability of the selection of water at any moment.

Page 316.

This probability is determined by the sum of the probabilities

$$\begin{aligned} \theta_{(600).3} &= \omega_{(600).3}^1 + \omega_{(600).3}^2 + \omega_{(600).3}^3 = 1 - \omega_{(600).3}^0 \dots \\ 1 - \omega_{(600).3}^0 &= 1 - C_3^0 \cdot p_{600}^0 (1 - p_{600}) = \\ &= 1 - (1 - 0.134)^3 = 0.35. \end{aligned}$$

Consequently, the unknown probability of joint selection by three presses will be equal to

$$\text{faiths/beliefs. } \{l_{3500} + l_{1500} + l_{600}\} = 0.21 \cdot 0.20 \cdot 0.35 = 0.0147.$$

The probability of joint selection four by presses - one by

effort/force 3500 t, one by effort/force 1500 t and two by effort/force on 600 t, of three they are established/installed, it will be expressed by the product

$$\text{faiths/beliefs. } (1_{3500} + 1_{1500} + 2_{600}) = p_{3500} \cdot p_{1500} \cdot \theta_{(600).3}^2,$$

where $\theta_{(600).3}^2$ is the probability, with which at any moment select/take water at least two of the established/installed three presses by effort/force by 600 t or, in other words, the probability, with which they select/take and the second, and the third of the established/installed presses, and it is eliminated only the probability, with which selects/takes only first press or there is no selection entirely. This probability on the basis of the theorem of the tracking of probabilities will be determined by the expression

$$\begin{aligned} \theta_{(600).3}^2 &= \omega_{(600).3}^2 + \omega_{(600).3}^3 = 1 - \omega_{(600).3} - \omega'_{(600).3} = \\ &= 1 - (1 - 0,134)^2 - C_3^1 p'_{600} (1 - p_{600})^2 = \\ &= 0,35 - 3 \cdot 0,134 (1 - 0,134)^2 = 1 - 0,65 - 0,3 = 0,05 \dots \end{aligned}$$

Consequently, the unknown probability of the joint selection of water four by presses will be equal to

$$\text{faiths/beliefs. } (1_{3500} + 1_{1500} + 2_{600}) = 0,21 \cdot 0,20 \cdot 0,05 = 0,0021.$$

By this expression the calculations of the probabilities of joint selection, obviously, can be finished, since probability into

0.0021 composes 0.21% only.

For the larger clarity the given calculations are given in Table 29.

As can be seen from Table 29, the probability of the joint selection of water by two presses by efforts/forces 3500 and 1500 t composes 4.2%, probability of the joint selection of water by three presses, i.e., by presses by efforts/forces 3500, 1500 and 600 t, composes 1.47%, and the probability of the joint selection of water four composes only 0.21% by presses. On the basis of the considerations presented about the maximum probability, for which should be designed the storage battery/accumulator (maximum probability we will consider equal to 1%), we accept, what with the water absorbing group of the frequently encountered combinations of presses is group of three first presses, i.e., effort/force 3500 t - 1 pcs, by effort/force 1500 t - 1 pcs and by effort/force 600 t - 1 pcs.

Page 317.

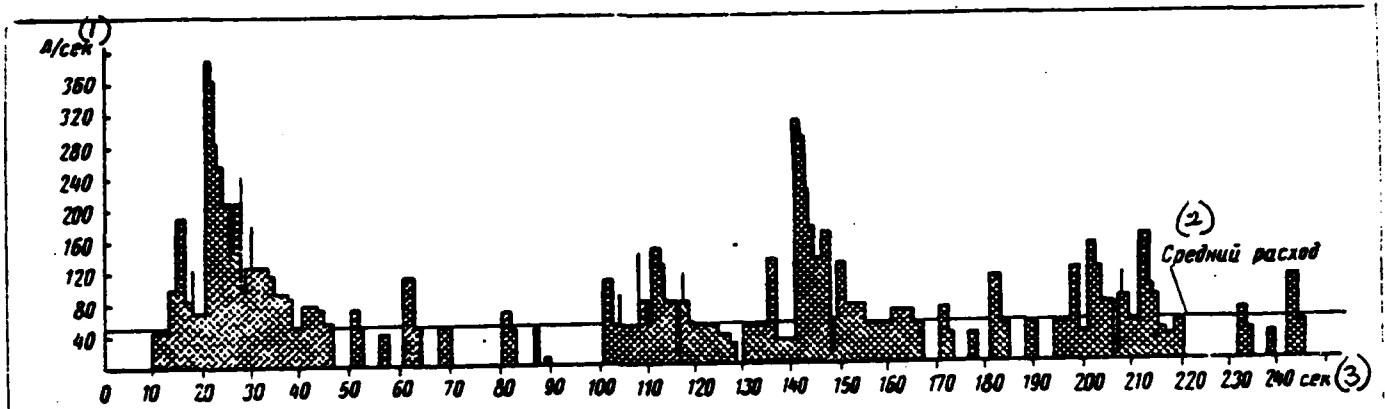

Fig. 291. Graph of the joint selection of high-pressure water by the installation, which is of the press effort/force 3500 t, press by effort/force 1500 t, three presses by effort/force on 600 t and three presses by effort/force on 300 t.

Key: (1). l/s. (2). Average/mean consumption. (3). s.

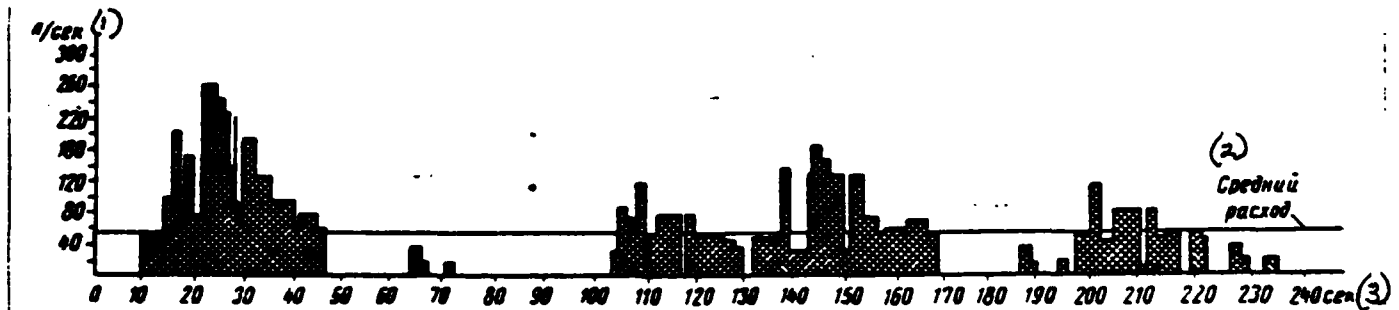

Fig. 292. Graph of the joint selection of high-pressure water by the installation, which is of the press effort/force 3500 t, press by effort/force 1500 t press by effort/force 600 t.

Key: (1). l/s. (2). Average/mean consumption. (3). s.

Page 318.

Only for this group of presses should be constructed the summary chart of the selection of water, combining time intervals with the greatest selection of water by each press. This graph is represented in Fig. 292. The working volume of storage battery/accumulator, determined according to this graph, is only 1240 l, i.e., to 625. it is less than on the graph Fig. 251. At the larger power of presses the difference as results could be even more considerable.

Dimensions of the Water Tank of Storage Battery

The volume of water bottle is composed of the working volume of liquid, loosened by storage battery/accumulator to presses, the lower emergency and upper standby of volumes (Fig. 293).

The lower emergency volume is necessary so that it would not occur the complete emptying of water bottle and breach/inrush of compressed air in the system of press in such a case, when on any by reason slowly operates/actuates equipment for control of station and

the valve of minimum level in time will not be closed.

The emergency volume of liquid must be such so that the time of the complete emptying of storage battery/accumulator from the moment/torque of including the lower emergency signal would be a sufficient for the manual inclusion/connection operator of the valve of minimum level and for its operation.

The upper reserve volume is provided for in that case, if equipment of the cutoff/disconnection of pumps with the filled bottle does not operate/actuate and this cutoff/disconnection it have to manufacture operator.

Table 29. Summary of the calculations of the probabilities of the joint selection of high-pressure water by presses.

(1) Одновременно отбирают воду прессы	(2) Расчетная вероятность в %
(3) Усилием 3000 т - 1 шт. 1500 т - 1 .	$0,21 \cdot 0,20 \cdot 100 = 4,2$
3000 т - 1 . 1500 т - 1 . 600 т - 1 .	$0,21 \cdot 0,20 (1 - \omega_{(600),3}^0) \cdot 100 = 1,47$
(4) 3000 т - 1 . 1500 т - 1 . 600 т - 2 .	$0,21 \cdot 0,20 (1 - \omega_{(600),3}^0 - \omega'_{(600),3}) \times 100 = 0,21$

Key: (1). They simultaneously select/take water of press. (2).
Calculated probability in %. (3). By effort/force ... t - 1 pcs. (4).
By effort/force ... t - 2 pcs.

Page 319.

The diameter of water bottle is determined by maximum fluid flow rate from the storage battery/accumulator and allowable speed of lowering the level of liquid in the storage battery/accumulator

$$D > 26 \sqrt{\frac{W_s}{\pi v}}, \quad (291)$$

where D - bore of water bottle in cm;

W_s - maximum fluid flow rate from the storage

battery/accumulator in l/min;

v - the allowable speed of lowering the level of liquid in the storage battery/accumulator in mm/s.

The height/altitude of working liquid column in the storage battery/accumulator in cm

$$H = \frac{4 \cdot 10^6 Q_a}{\pi D^3}, \quad (292)$$

where Q_a - the working volume of liquid in the storage battery/accumulator in l.

The velocity of lowering the level of liquid in the bottle (v) according to experimental data must not exceed 250 mm/s.

Equal to 3-5 s we accept the time (t_p) of manual inclusion/connection and operation of the valve of minimum level or bypass [castrated] valve of the pump.

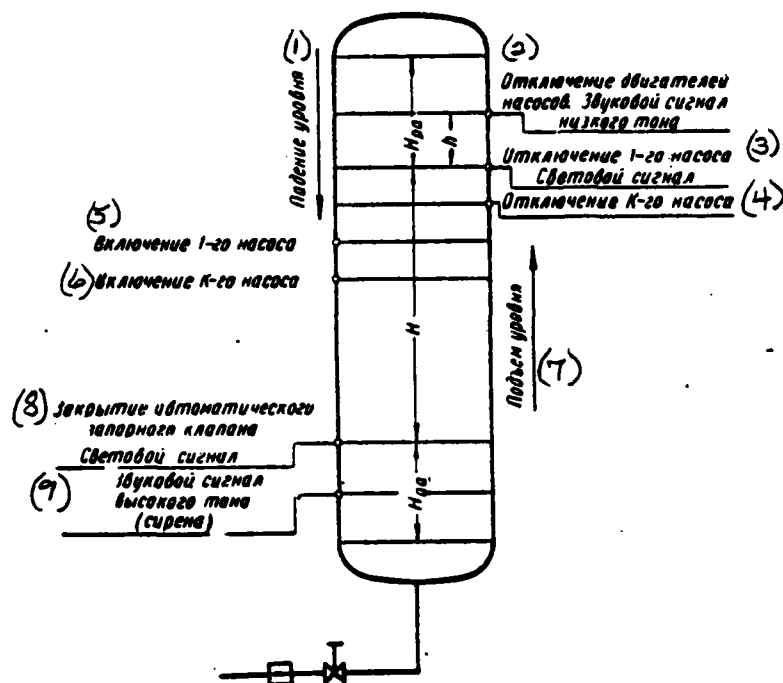

Fig. 293. Controlled/inspected levels of liquid in the storage battery/accumulator: H , $H_{ав}$ and $H_{ст}$ — respectively the height/altitude of working, emergency and standby liquid columns.

Key: (1). Drop in level. (2). Cutoff/disconnection of the engines of pumps. Sound signal of the bass tone. (3). Cutoff/disconnection of the 1st pump. Indicating light. (4). Cutoff/disconnection of the k pump. (5). Start of the 1st pump. (6). Start of the k pump. (7). Raising level. (8). Coverage of automatic check valve. Indicating light. (9). Sound signal of high tone (sirens).

The height/altitude of emergency liquid column in the storage battery/accumulator will be determined from the relationship/ratio

$$H_{aa} = \frac{v t_p}{10} \quad (293)$$

and the emergency volume of liquid is respectively equal to

$$Q_{aa} = \frac{\pi D^3}{4} H_{aa} \cdot 10^{-3} \text{ l.} \quad (294)$$

The height/altitude of the standby volume of storage battery/accumulator is determined from the relationship/ratio

$$H_{pa} = \frac{20 \cdot W_n}{D^3} t_p \text{ cm} \quad (295)$$

and the respectively reserve volume of the storage battery/accumulator

$$Q_{pa} = \frac{W_n \cdot t_p}{60} \text{ l.} \quad (296)$$

The overall height of the cylindrical part of the water bottle must be

$$H_{ob} > H + H_{aa} + H_{pa}. \quad (297)$$

During sizing of the storage battery/accumulator, which feeds the presses, which have the balancing cylinders, constantly connected to the storage battery/accumulator, it is necessary to consider that the working volume of storage battery/accumulator can be filled up to the moment/torque, when the crossheads of presses are located in the upper position. With the idling of presses the storage

battery/accumulator will be additionally filled with the liquid, displaced/superseded from the balancing cylinders, and its level will be built up above the level of the cutoff/disconnection of latter/last pump.

Total Volume of Bottles of Storage Battery

The volume of air in the storage battery/accumulator is determined on the pressure differential of working fluid adopted.

The expansion of air in the bottle occurs according to the polytropic law with the coefficient of politropic curve $n=1.3-1.35$.

$$p_{\max} Q_{\text{ex}}^n = p_{\min} Q_{\text{ex}}^n, \quad (298)$$

where Q_{ex} and Q_{ex} - respectively the volume, occupied by air in the beginning and at the end of the expenditure of liquid from the storage battery/accumulator;

$$Q_{\text{ex}} = Q_{\text{ex}} + Q_{\text{a}}, \quad (299)$$

where Q_{a} - maximum volume of liquid in the storage battery/accumulator in l.

Page 321.

Let us designate:

$$\frac{p_{\min}}{p_{\max}} = \alpha.$$

Then

$$\left(\frac{Q_{em}}{Q_{em} + Q_a}\right)^n = \alpha; \quad Q_{em} = Q_a \frac{\alpha^{\frac{1}{n}}}{1 - \alpha^{\frac{1}{n}}}$$

Relation $\frac{p_{min}}{p_{max}} = \alpha$ in the contemporary press installations is taken as the approximately equal to 0.9.

The total volume of the bottles of storage battery/accumulator will be equal to

$$Q = Q_a \left(1 + \frac{\alpha^{\frac{1}{n}}}{1 - \alpha^{\frac{1}{n}}}\right) + Q_{em} \quad (300)$$

where Q_{em} — emergency volume of liquid in the storage battery/accumulator, usually taken to approximately equal to
At the values accepted:

$$\alpha = 0,9; \quad n = 1,35 \quad \text{and} \quad Q_{em} = 0,3Q_a;$$

$$Q = 13,35Q_a + 0,3Q_a = 13,65Q_a \quad (301)$$

Power of Compressor for Battery Charging.

Battery charging is produced by compressed air after installation or repair of station.

During operation of station the compressor is utilized rarely, only for pumping of air, if there are its clearance losses in

connections of conduit/manifold, and also for the compensation of losses due to the dissolution of air in the working fluid. Compressor is selected of calculation of battery charging for the relatively long time - 2-3 days and more continuous operation. Under these conditions a quantity of atmospheric air, drawn in by compressor in the hour, is determined from the formula .

$$Q_k = \frac{Q_{air} p_{o, max}}{24 \cdot m} \quad (302)$$

where $p_{o, max}$ — maximum air pressure in the storage battery/accumulator in kg/cm².

m - calculated number of days of continuous operation of compressor.

Usually the power of the electric motor of the compressor of the pump-and-battery station is 5-25 kW. A lift of pressure in the storage battery/accumulator can be carried out also with the aid of the compressor, which develops pressure 6-8 kg/cm², and by the repeated charge of water bottle from the pump.

Page 322.

In this case the air and water bottles the battery chargings must be into the period divided by the well ground/wiped check valve.

Reference Levels of the Working Fluid of the Storage Battery

In the storage battery/accumulator are fixed/recorded the specific levels of liquid, on which the operation of the corresponding equipment for control of the pump-and-battery station occurs.

With the fluid flow rate from the storage battery/accumulator at the specific levels occurs the series connection of pumps to the supply to liquid into the line a press-storage battery/accumulator, which is accomplished/realized by closing the bypass valves of pumps.

At the level, which corresponds to the complete flow rate of the working volume of liquid from the storage battery/accumulator, the automatic check valve, which ceases further fluid flow rate, is switched on. This level precedes the level, at which is switched on the indicating light, which warns of operator about the fact that further fluid flow rate from the storage battery/accumulator will lead to the coverage of the automatic check valve of minimum level. With this signal the operator must arise in the knob/button of the manual closing of valve in order to avoid the possibility of the complete emptying of storage battery/accumulator, if on any reasons equipment for the automatic control of station does not operate/actuate.

It is lower than the level, at which the automatic check valve of minimum level operates/wears, is fixed/recorded the level, on reaching/achievement of which is supplied the sound signal (usually siren), which indicates that this valve did not operate/actuate, and the operator of station must rapidly close the check valve, established/installed on the line of the battery-press, but the operators of presses must stop presses.

Sometimes for decreasing the quantity of monitors indicating light is combined with the sonic.

During the supplying with the pumps of liquid into the storage battery/accumulator are fixed/recorded the levels, at which the consecutive switching of pumps to the no-load operation occurs.

Switching to the no-load operation of latter/last pump is accompanied by the supply of the light signal, which notifies the operator about the fact that the storage battery/accumulator is completely filled. In the case if for any reasons the translation/conversion of pumps into the no-load operation does not occur, for warning/preventing overfilling of storage battery/accumulator is fixed/recorded the upper emergency level, upon

reaching/achievement of which the electric motors of pumps are disconnected from the network/grid and sound signal (usually the bass tone) is supplied.

The levels of working fluid in the storage battery/accumulator are schematically shown in Fig. 293.

Lower is the most critical/heaviest-duty level, on which automatic check valve must be closed. Therefore when storage battery/accumulator has several water bottles, which work to one network/grid and disconnected by one check valve, for each water bottle must be provided for the independent apparatuses of the control/check of lower level, the giving impulses/momenta/pulses for covering the automatic check valve.

Page 323.

Conversion of Pumps into the No-Load Operation.

By the most widely used device, which uses for the translation/conversion of pump into the no-load operation, is the bypass (castrated) mechanically controlled valve. One of the constructions/designs of the bypass valve is shown in Fig. 294.

Valve is controlled by the auxiliary, two-valve (Fig. 295) or slide-valve distributors, made usually with electromagnet.

Cavity under the relief piston of the bypass valve with the aid of this distributor is connected either with the storage battery/accumulator, and then proves to be open and pump in this case runs idle, supplying liquid into the tank, from which it feeds or with the drain, and then valve is closed, and the pump feeds liquid into the storage battery.

The use/application of the valve indicated has the deficiency, that the engine of pump, and also pump itself are loaded and are unloaded almost instantly, giving rise to the impacts/shocks in the power networks/grids (electrical and hydraulic). Therefore in the powerful/thick pumps their translation/conversion into the no-load operation frequently is accomplished/realized with the aid of the consecutive positive opening of their intake valves.

For the valve lift the pneumatic cylinders (Fig. 296), controlled by three-way slide valves, which affect from the electromagnets (Fig. 297), are applied.

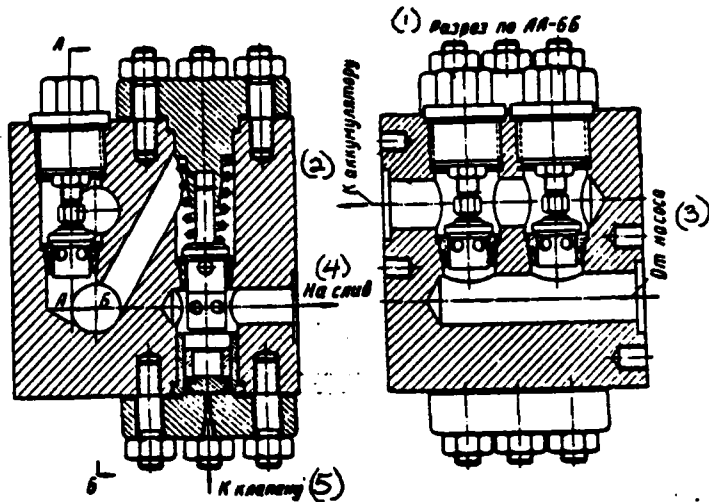

Fig. 294. Construction/design of the bypass valve of pump.

Key: (1). Section/cut on AA-BB. (2). to storage battery/accumulator.
 (3). From the pump. (4). To the drain. (5). To the valve.

Page 324.

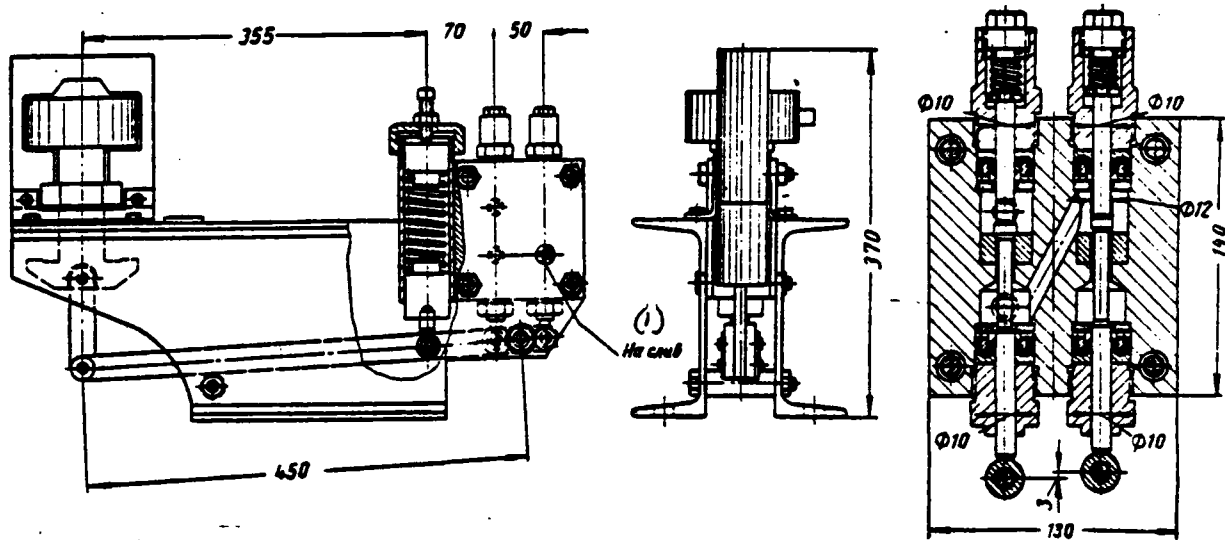

Fig. 295. Two-valve distributor, controlled by electromagnet.

Key: (1). To the drain.

Page 325.

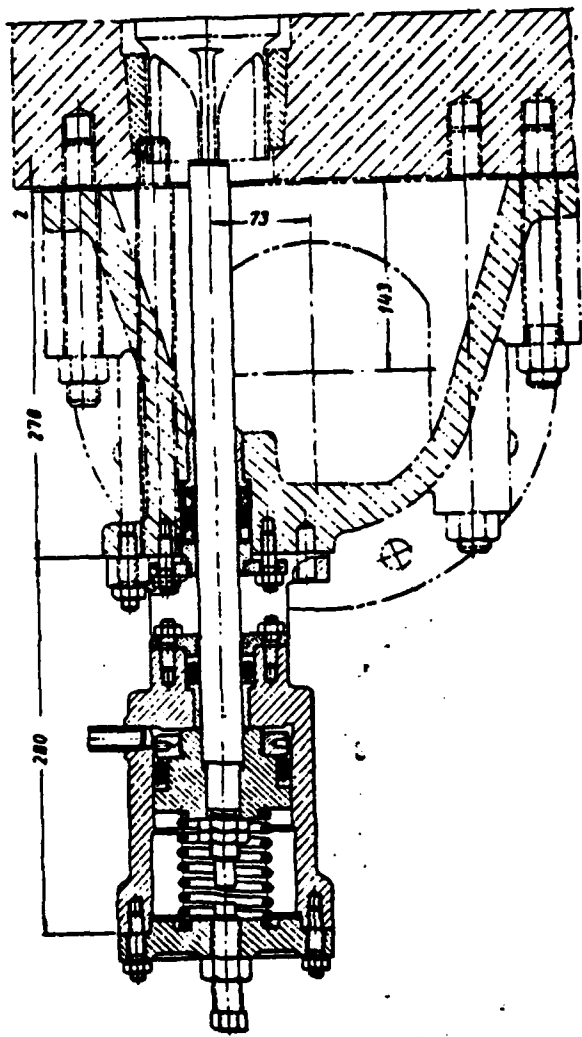

Fig. 296. Pneumatic cylinder for lifting the intake valves of pump.

Page 326.

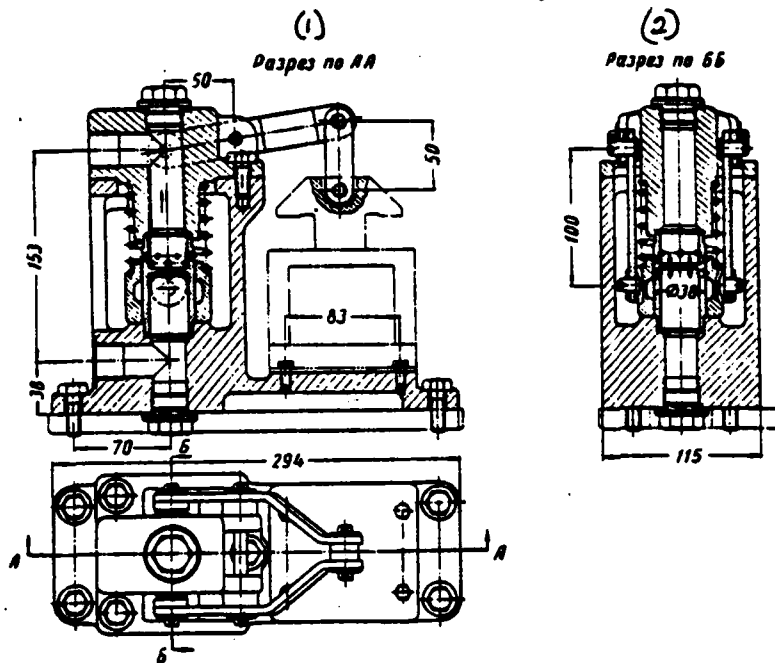

Fig. 297. Three-way the air valve, controlled by electromagnet.

Key: (1). Section/cut on AA. (2). Section/cut on BB.

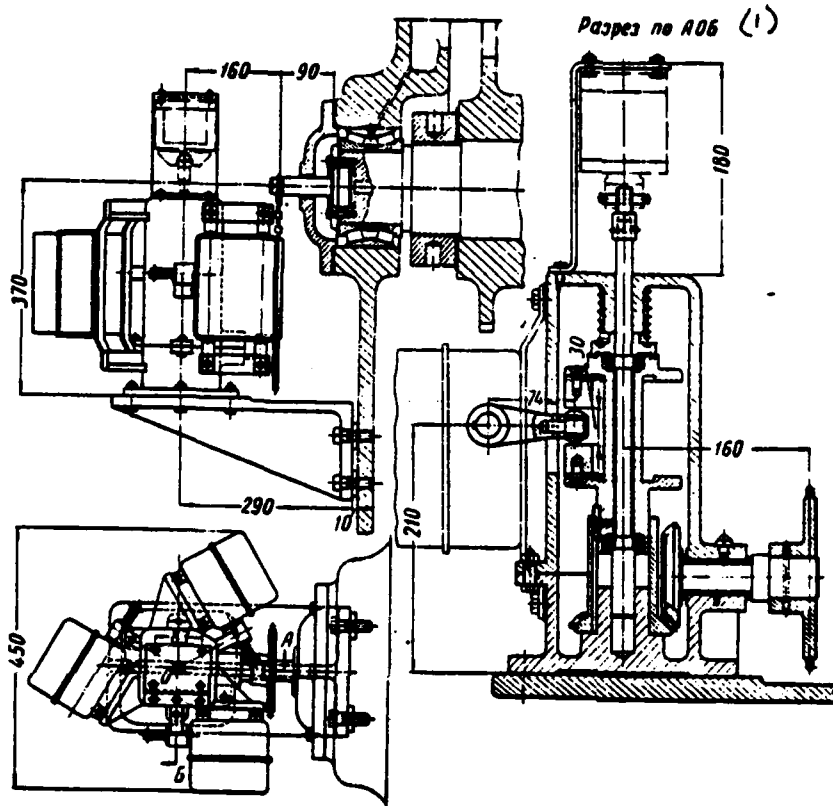

Fig. 298. Apparatus for the series connection of the valves, controlled by the pneumatic cylinder of the lift of the intake valves of pump.

Key: (1). Section/cut on AOB.

Page 327.

For the realization of consecutive opening and closing of valves

is applied the apparatus, whose construction/design is shown in Fig. 298. On the housing of apparatus the electrical contacts, whose number corresponds to a number of three-way air valves, are assembled. Contacts are alternately closed by the hammer/cam, which rotates from the crankshaft of pump. During the closing of contacts the electromagnet of the corresponding air valve is connected to the network/grid and are opened/disclosed it for the pass of air into the cylinder. This electromagnet is switched on from the apparatus of the checking of the levels of liquid in the bottle.

Designs of Automatic Check Valves Minimum Level.

The valve of minimum level, which warns the emptying of storage battery/accumulator, is the controlled check valve.

In the closed position it must pass liquid only in one direction - from the pump into the storage battery/accumulator.

Valve is the most critical/heaviest-duty apparatus of the pump-and-battery station and must quick-operating on the command/crew of the apparatus of the checking of the lower level of liquid in the bottle. The action of it must be absolutely reliable.

With the delay of the operation of this valve the compressed air

tanks of the storage battery/accumulator through the press can be connected with the filler low-pressure tank, which will lead to the explosion of the latter.

There are several constructions/designs of valves. The schematic of the valve of the simplest construction/design is shown in Fig. 299.

Its relatively low reliability is a shortcoming in this construction/design of valve, since in the case of breach/inrush or blockage of conduit/manifold, which connects over-valve cavity with the storage battery/accumulator, valve can not be closed.

The valves, which are opened/disclosed by the auxiliary cylinder (Fig. 300), are of a more fail-safe design, which is controlled by two-valve or slide-valve distributor.

With the connection of auxiliary cylinder with the drain the valve is closed under the spring effect and pressure, created by the flow, which affects on the valve.

The effort/force of auxiliary cylinder can be selected insignificant, designed only for holding of valve in the open position:

$$P_n = \frac{\pi d_n^4}{4} p_n = \xi \frac{v^2}{20g} \cdot \frac{\pi d_n^2}{4} + \Pi_n, \quad (303)$$

where ξ - drag coefficient of valve; $\xi=16-20$;

v - rate of flow of the liquid through the valve in m/s;

d_* - diameter of auxiliary cylinder;

d_v - diameter of valve;

Π_* - effort/force of the spring, which affects on the valve, in kg.

Page 328.

Valve opening in this case proceeds by the flow from the pump, which develops the pressure, somewhat greater than the pressure of liquid in the storage battery/accumulator.

This performance provides completely reliable operation of station, since valve cannot be opened, if pumps do not supply liquid into the storage battery/accumulator. A shortcoming in this performance is the fact that for valve opening in the beginning of operation of station is necessary launching/starting pump even when

water bottle is completely filled. During launching/starting of pump for valve opening and its subsequent then translation/conversion into the no-load operation additional equipment is necessary.

Therefore auxiliary cylinder frequently is relied on the effort/force, capable to open valve without the aid of pressure from the pump, i.e., the diameter of the plunger (or piston) of cylinder is taken with the greater diameter than the diameter of valve ($d_1 > d_2$).

Apparatuses of the Checking of the Level of Liquid in a Storage Battery

Designation/purpose of apparatuses - to impart at the specific levels of liquid in the water bottle, current pulses for switching of instruments and contacts of the electrical circuits of drive and control of station.

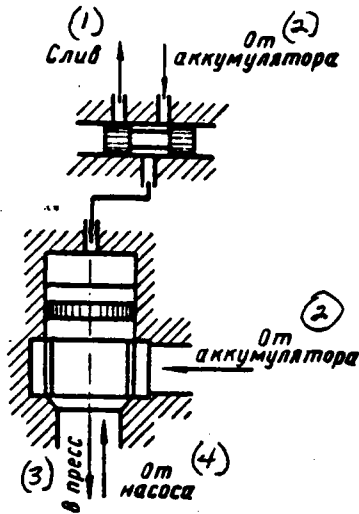

Fig. 299.

Fig. 299. Schematic of the automatic check valve of minimum level.

Key: (1). Drain. (2). From the storage battery/accumulator. (3). In the press. (4). From the pump.

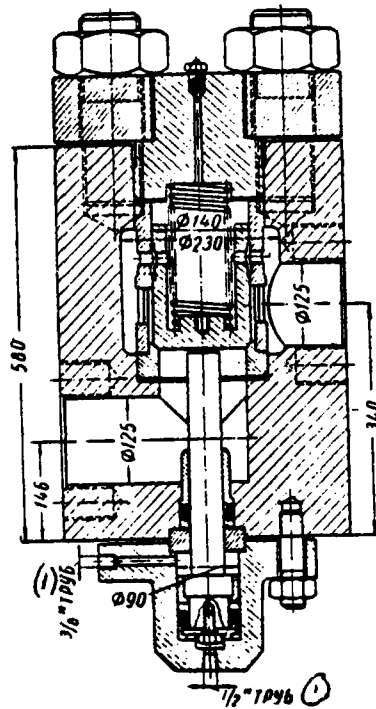
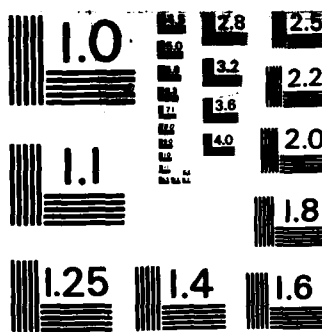

Fig. 300.

Fig. 300. Construction/design of the automatic check valve of minimum level.

Key: (1). ducts/tubes/pipes.



MICROCOPY RESOLUTION TEST CHART
NATIONAL BUREAU OF STANDARDS - 1963 - A

Page 329.

Apparatuses must be completely reliable and reliable in the work, since carelessness of their work or nonoperation in the necessary time can lead to the serious emergency, i.e., to the explosion of tanks or bottles, which consist the large volumes of air under the pressure.

Since the pressure of liquid in the bottle oscillates insignificantly, as the impulse/momentum/pulse for operating the apparatuses are utilized either moving level of liquid or pressure from the liquid column in the storage battery/accumulator.

The apparatuses, which operate/wear from a change of the pressure of liquid in the storage battery/accumulator, for example the contact manometers, apply rarely and mainly as the understudies.

There are many different constructions/designs of apparatuses, based on different operating principles. The most widely used apparatuses, which well recommended themselves in the work at the pump-and-battery stations, are described below.

Multi-float apparatus with permanent magnets (Fig. 301). The apparatus is the vertical steel housing 1 of extended form, within which longitudinal through channel and series/row of transverse ones are drilled. Housing is furnished next to the water bottle of storage battery/accumulator so that its horizontal cavities would be furnished against the levels, at which it is desirable to switch diagram. In each cavity is placed rocking horizontal lever 2, to one end of which is fastened/strengthened the float 3, opened from below, and at other end - U-shaped permanent magnet 4. The cover/cap, which hermetically closes cavity, has hollow extension, inserted inside the cavity and which is located between the ends of the horseshoe of magnet. Inside the extension from the side of atmospheric pressure is inserted the core, to which mercury switch 5 is fastened/strengthened. The housing of apparatus is connected with upper and lower ends of water bottle with the aid of the separate ducts/tubes/pipes. In this case the water in the apparatus is established/installed at the level of water in the bottle, as in the communicating vessels. With a change in the level in the bottle they begin to operate/wear separate floats in the housing of apparatus, as a result of which the permanent magnets connected with their levers are turned from one end position to another.

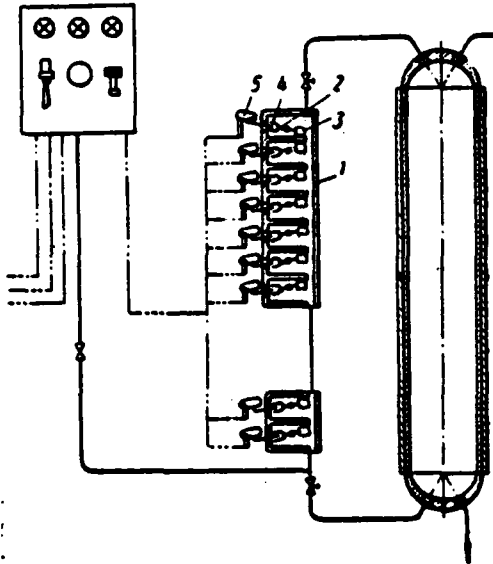

Fig. 301. Schematic of multi-float apparatus with the permanent magnets for the checking of the levels of liquid in the storage battery/accumulator.

Page 330.

This leads to switching of contacts in mercury switches and corresponding switching in operation of entire station.

The part of the floats, which correspond to the lower levels of switching, they are carried out into the separate housing, connected by connecting pipe with the upper part of the regulator.

Fig. 302 shows the construction/design of float with the magnet, while in Fig. 303 - the construction/design of the unit of the installation of float with the magnet in the housing of apparatus.

Fig. 304 shows the constructions/designs of the mercury contacts used: the contact (Fig. 304a), which is closed during the incidence/drop in the float and adjusted on the upper maximum level, at which are disconnected from the feeding the electric motors of pumps; the contact (Fig. 304b), which is closed during the lift of float and adjusted on all remaining levels.

Positive the special features/peculiarities of the described apparatus are: simplicity of device, small dimensions, explosion-proof character, reliability of action. The impossibility of changing the position of the levels, which are subject to checking, is a shortcoming in the apparatus.

Float apparatus with the photocell (Fig. 305). Apparatus consists of separate communicating chambers/cameras 1, within which there are floats 2.

The chambers/cameras assembled together are connected with the storage battery/accumulator: with its upper part, filled with air, and with the lower part, filled with water.

DOC = 83120715

PAGE

613

In two opposite chamber walls are windows, overlapped by armor-plate glass 3.

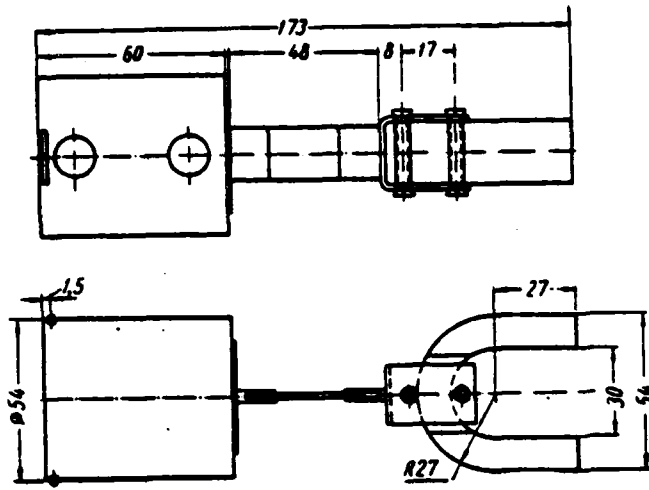

Fig. 302. Construction/design of float with the magnet, used in the apparatus of the checking of the level of liquid in the bottle of storage battery/accumulator.

Page 331.

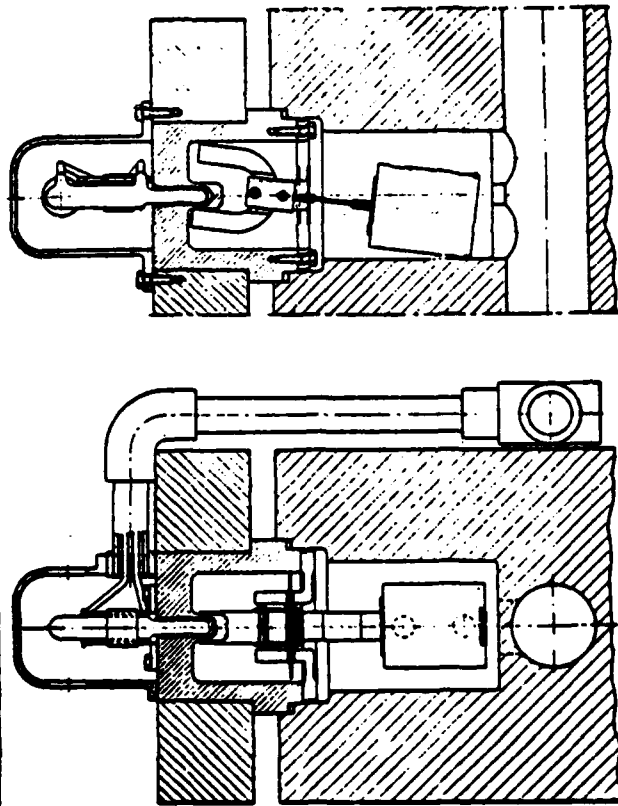

Fig. 303. Installation of float with the magnet in the housing of the apparatus of the checking of the level.

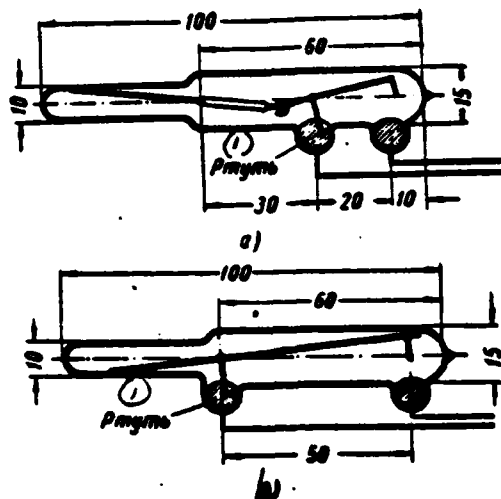

Fig. 304. Mercury contacts: a) the contact, which is closed with the lowering of float; b) the contact which is closed during the lift of float.

Key: (1). Mercury.

Page 332.

Against one window is established/installed photocell 4, while against another - tube 5. The work of apparatus is based on creation by the photocell of impulse/momentum/pulse in the direction to it of beam of light.

During lift and dropping of float together with water level in

the storage battery/accumulator, the float screens photocell from the light/world or are opened/disclosed it to the light/world and thus through the photocell it acts on the electrical control network of station.

Shortcomings in the apparatus are the rapid pollution/contamination (blackout) of glasses and the difficulty of the tight fit of glasses in the windows of chamber/camera, and also the impossibility of changing the position of the levels, which are subject to checking.

Mercury apparatus with the rotary ring (Fig. 306). the housing of apparatus is duct/tube/pipe 1, bent into the ring, which has an internal diametric cross-beam and supported in its center to the prism support 2. Duct/tube/pipe has within a partition/baffle 3, arranged/located across. Diametrically opposite to partition/baffle to the duct/tube/pipe is fastened load 4. The interior of duct/tube/pipe is filled to half with mercury 5. Between partition/baffle and surface of mercury from each side separate cavity is formed, thus.

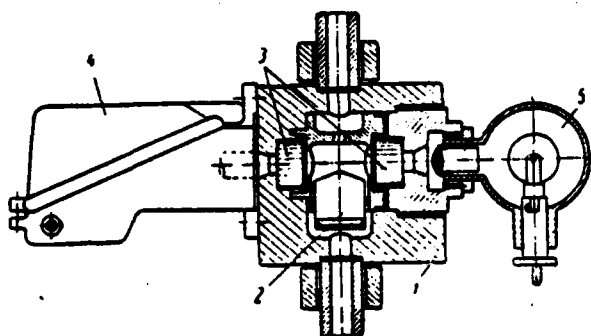

Fig. 305. Float apparatus with the photocell.

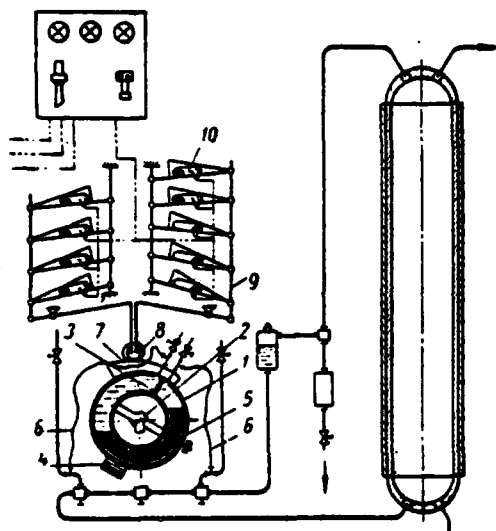

Fig. 306. Schematic of mercury apparatus with the rotary ring for the checking of the levels of liquid in the storage battery/accumulator.

Page 333.

Each of the cavities is connected with the aid of flexible hose 6 with the ducts/tubes/pipes, which lead to the lower and upper parts

of the water bottle of storage battery/accumulator. A change in the water level in the storage battery/accumulator leads to a change in the pressure on mercury, which is moved under the action of this pressure in the duct/tube/pipe of regulator in the direction of the cavity, connected with the upper part of the bottle. The displacement of mercury causes displacement with the upper part of the bottle. The displacement of mercury produces the center-of-gravity disturbance of ring and its rotation around the center, fastened/strengthened to the prism supports. During the rotation of ring the arm of the load, fastened to the rod in the lower part of the housing, increases. With the equality of moments/torques from mercury and from the constant load the ring comes into the state of equilibrium. To the upper part of the ring is fastened/strengthened shaped the cam 7, during the rotation of the rings affecting two rollers 8, which are fastened/strengthened to the ends of lever systems 9, with mercury switches and with fixed contacts 10. During the rotation of ring and hammer/cam connected with it the position of the level of mercury in the ampules of switches changes. In the specific position, established/installed for each switch, with respect to the level of liquid controlled/inspected by it in the bottle, occurs closing/shorting (or breaking) contacts in mercury switch, that also is impulse/momentum/pulse for changing the switchings in the electrical overhead electric transport power line of station.

The positive special features/peculiarities of the described apparatus are: the reliability of action, the possibility of a precise control and changes in the controlled/inspected levels, explosion-proof character and possibility of connection with recording instruments. The relative complexity of its construction/design and the need of applying the flexible hoses to the high pressure is a shortcoming in the apparatus.

Mercury apparatus with the rod contacts (Fig. 307). The apparatus is steel forged box 1 with two cylindrical cavities, connect/joined together on the schematic of the connecting vessels. The cavities of box are closed from above by massive covers/caps 2, which have sealings/packings/compactions. In the cover/cap of left cavity contact bars 3 with the platinum tips are inserted. Inside the box of regulator mercury 4 is filled in the specific quantity. The left cavity of apparatus is connected by duct/tube/pipe with the top of hydraulic bottle, and right cavity - with its bottom.

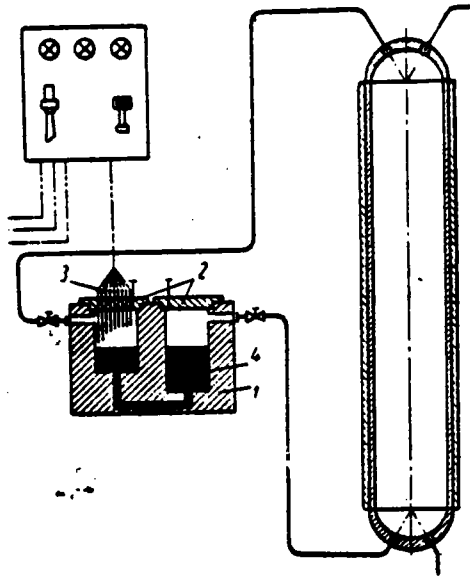

Fig. 307. Schematic of mercury apparatus with the rod contacts for the checking of the levels of liquid in the storage battery/accumulator.

Page 334.

During the adjustment of installation left cavity of the apparatus remains that filled with air, and right is filled above mercury with the working fluid of storage battery/accumulator. With raising the level in the storage battery/accumulator by the surface of mercury in the right cavity of apparatus it begins to press liquid column. As a result of this mercury begins to overflow into the left cavity to the onset of the equality of the pressures of excessive liquid column in

the bottle and the excessive column of mercury in the apparatus.

The relation of the heights/altitudes of these columns is equal to the relation of the specific gravity/weights of mercury and water. Thus, change in altitude of mercury column in the regulator will be approximately 13 times less than change in altitude liquid column in the storage battery/accumulator (during the calculation of the fluctuation of the level of mercury necessary to consider the weight of air column above mercury). With raising the level of mercury in the left cavity of apparatus the level meets contact row with the platinum tips, arranged/located on the levels, which correspond to the levels of liquids in the bottle, at which it is desirable to carry out one or the other switchings in the diagram of the control of the pump-and-battery station and to produce closing/shorting or breaking the auxiliary electrical circuits. The latter act on the contactors of electric diagram and they produce, thus, working switchings.

One of the constructions/designs of apparatus, developed TsNIITMASH [ЦНИИТМАШ - Central Scientific Research Institute of Technical Mechanical Engineering], it is shown in Fig. 308. The positive special features/peculiarities of this apparatus are: simplicity of device, compactness, reliability of action. Shortcomings in the apparatus include: the need of applying the

expensive platinum contacts, the danger of an explosion of oil vapors as a result of the possible sparking of contacts and need for the periodic surface cleaning of mercury.

Mercury apparatus with the induction float device (Fig. 309). The apparatus in question is in principle similar to the apparatus, shown in Fig. 307, and differs in terms of the fact that instead of the rods with the platinum contacts on the surface of mercury in the left cavity of apparatus is a float 1 with core 2 of soft iron. Core passes through induction coils 3.

With a change in the level of mercury in the apparatus the core is moved, changing electrical conductivity of coils, that also is initial impulse/momentum/pulse for the production of switchings in the electrical control circuit.

Figure 310 gives the working diagram of the pump-and-battery station, in which the apparatus, shown in Fig. 309, is used. The action of this apparatus in the assembly with others, used in this case occurs as follows. With a change in the level of liquid in the bottle of storage battery/accumulator the apparatus of 8 checkings of level imparts impulse/momentum/pulse to the indicator of 9 levels of liquid in the bottle. During the fluctuation of the level of liquid in the bottle level indicator acts on pneumatic controller 10.

Depending on the rotation of the axis/axle of indicator in the airline, which goes to pneumo-electrical contacts 2, the pressure, proportional to the height/altitude of liquid column in the storage battery/accumulator, is established. With the aid of these contacts the control of the mechanisms of the pump-and-battery station is accomplished/realized.

Page 335.

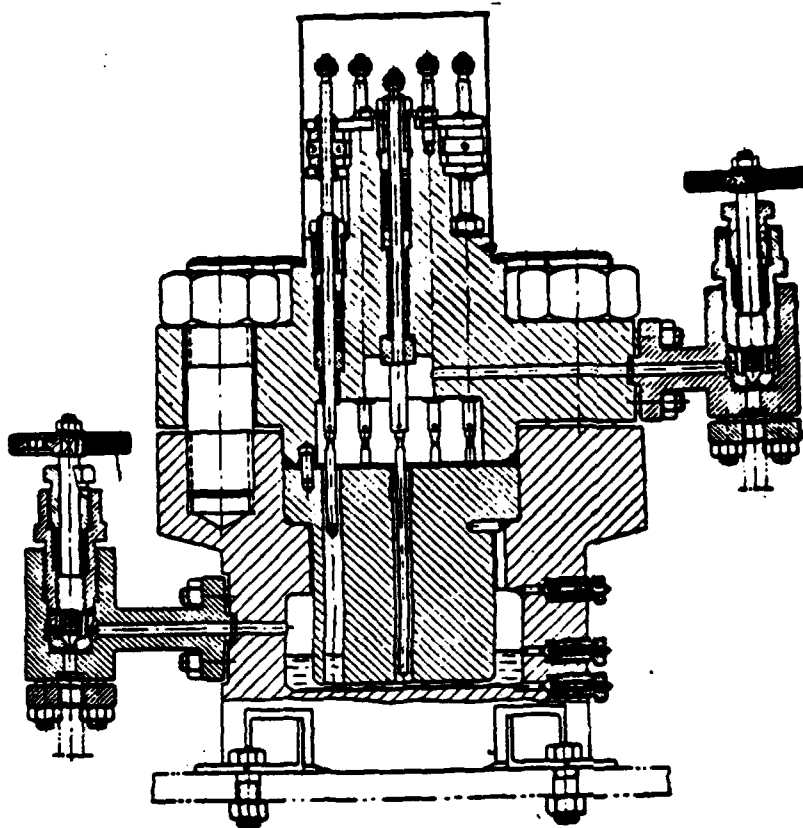

Fig. 308. Construction/design of mercury apparatus with the rod contacts for the checking of the levels of liquid in the storage battery/accumulator.

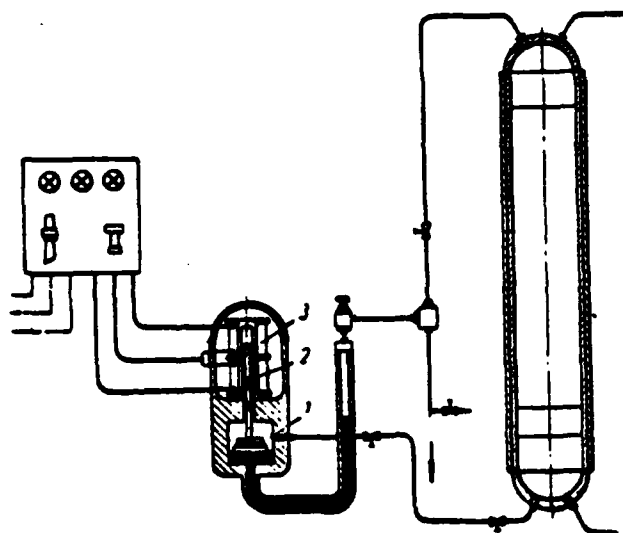

Fig. 309. Schematic of mercury with the induction float device apparatus for the checking of the levels of liquid in the storage battery/accumulator.

Page 336.

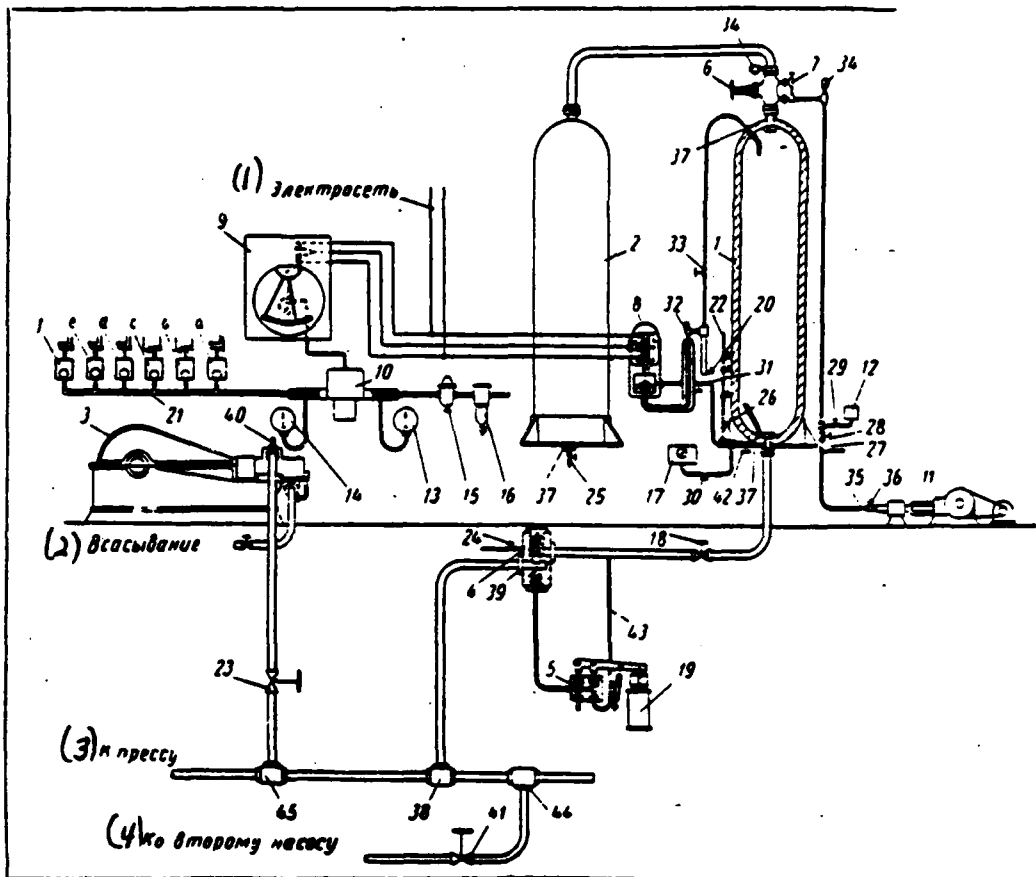

Fig. 310. The working diagram of the pump-and-battery station: 1 -
 2 - air cylinder;
 hydraulic bottle; 3 - horizontal three-plunger pump; 4 - automatic
 check valve of minimum level; 5 - two-valve distributor; 6 - check
 valve; 7 - check valve on the auxiliary line of valve 6; 8 -
 apparatus of the checking of the level of liquid; 9 - liquid level

gauge; 10 - pneumatic controller; 11 - compressor; 12 - electropneumatic switch for the self-catching of compressor; 13 - manometer for the checking of pressure, which enters from the network/grid of air; 14 - manometer for the checking of the air pressure, which enters pneumo-electrical contacts; 15 - pressure regulator of air; 16 - filter for air; 17 - the contact manometer for the cutoff/disconnection of electric motors with nonoperation of idling valve of pump; 18 - shutoff valve; 19 - electro-hydraulic apparatus for the valve lift of distributor; 20 - shutoff valve; 21 - pneumoelectric contacts; a - normally opened - idling of the first pump; b - normally closed - the inclusion of the first pump to the supply into the bottle; c - opened - normally holds automatic check valve in the closed position on the level of liquid in the bottle of that below minimally permitted; d - normally-closed - start of the second (in the diagram on it is shown) pump to the supply into the bottle; e - normally opened - inclusion/connection of indicating light with the work of pumps; f - normally opened - idling of the second pump; 22 - conduit/manifold with the valves/gates for the manual checking of the level of liquid in the bottle; 23-33 - shutoff valves; 34 - safety valve; 35 - check valve; 36 - safety valve of compressor; 37 - attachment/connection of the apparatus of the checking of the levels of liquid; 38 - tee; 39 - flange; 40 - safety valve of pump; 41 and 42 - shutoff valve; 43 - drain plug; " - tee.

Key: (1). Electric system. (2). Suction. (3). To the press. (4). To the second pump.

Page 337.

The diagram of pneumatic controller is shown in Fig. 311.

In the controller air along duct/tube/pipe 1 is fed and through throttle 2 and nozzle 3 it emerges in the atmosphere. Shutter/valve 4, which overlaps nozzle 3 or which throttles the air flow, which comes out from the nozzle, is connected with the axis/axle of level indicator and, thus, pressure in line 1, in the cavity of controller, it is set proportional to the height/altitude of liquid column in the storage battery/accumulator.

With the pressure increase in cavity 5 the membrane/diaphragm, fastened/strengthened to bellows 6, is moved. This membrane/diaphragm is connected with plate 8, which throttles the entry of air through nozzle 10 into cavity 7 of the output/yeild of air from this cavity through nozzle 9 in the atmosphere. With the displacement of the membrane/diaphragm down the pressure in cavity 7 is raised, and vice versa, with the displacement of the membrane/diaphragm upward (during the larger opening of nozzle 3 by shutter/valve 4) the pressure in cavity 7 falls. Cavity 7 is connected with pneumo-electrical

contacts, adjusted to the different pressure.

Mercury apparatus with floats, which directly affect the contacts (Fig. 312). This apparatus is similar to that shown in Fig. 309, but has the difference, that the floats, being moved with the level of mercury, close or they disconnect the mercury contacts, with the aid of which the corresponding switchings in the electric system of pumping-accumulator station occur.

Simplicity of its diagram is the advantage of apparatus; by shortcoming - relatively low sensitivity and complexity of testing the reasons for the malfunction of apparatus.

Apparatus with the float device (Fig. 313). Apparatus is small bottle 1 (or the group of bottles), connected with storage battery/accumulator 2 at two levels, situated on the small distance from each other. Bottle is connected with the compressed air tanks of storage battery/accumulator. In the bottle of apparatus float 3 with rod 4, released through the sealing/packing/compaction outside is located.

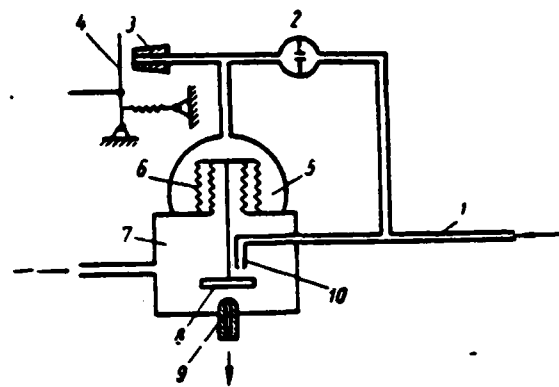

Fig. 311. Diagram of pneumatic controller.

Page 338.

To the end of the rod is fastened/strengthened the core, moving in the induction coils, which are arranged/located on the specific levels, which correspond to the controlled/inspected levels in the bottle. A change in electrical conductivity of coils in transit through them of core is utilized as the impulses/momenta/pulses for switchings of the apparatuses of station. The displacement of rod can be also used for the direct closing of contacts of the control of the storage battery/accumulator of station. When the level of liquid fluctuates between the ducts/tubes/pipes, which connect of storage battery/accumulator with the apparatus, the float of the latter is moved together with the level of liquid to the same value. After the liquid in the storage battery/accumulator will overlap upper tube,

float in the bottle will be moved to the considerably smaller value in the comparison with the value of a change in the level of liquid in the storage battery/accumulator. The displacement of float will be proportional to air compression in the bottle under the action of liquid column in the storage battery/accumulator.

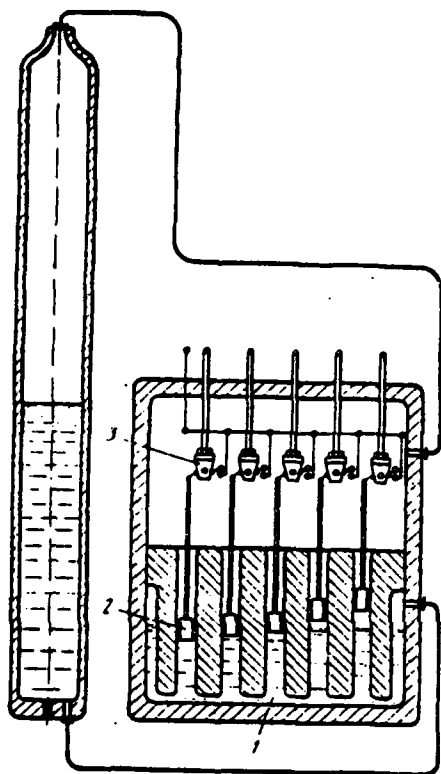

Fig. 312.

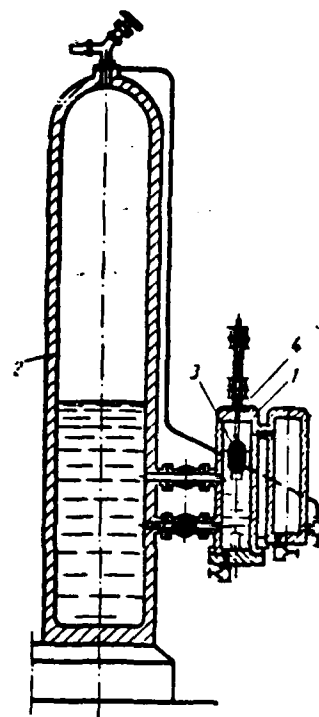

Fig. 313.

Fig. 312. The schematic of mercury apparatus with the floats, which directly affect the contacts: 1 - mercury; 2 - float; 3 - contact.

Fig. 313. Schematic of apparatus with the float device.

Page 339.

Assuming that the air compression in the bottle occurs on the isotherm, the displacement of float will be

$$pQ = (p + 0.1H)(Q - fh); \quad (304)$$

$$h = \frac{0.1 \cdot H \cdot Q}{p + 0.1H}.$$

where h - displacement of float;

p - initial air pressure in the storage battery/accumulator;

Q - initial volume of air in the apparatus up to the moment/torque of the filling with its liquid to the level of upper union pipe;

f - cross-sectional area of the hydraulic bottle of apparatus;

H - height/altitude of liquid column in the storage battery/accumulator, measured from the upper union pipe.

Its relative simplicity of device, explosion-proof character, precision/accuracy of readings/indications, possibility of the adjustment of apparatus to the checking of different levels are advantages of apparatus.

Shortcoming are complexity, accomplishings of sealing/packing/compaction of rod against leakages of air, taking into account that this sealing/packing/compaction must give minimum resistance.

Induction apparatus (Fig. 314) the housing of apparatus is stand pipe 1 of the nonmagnetic material, able to maintain/withstand high pressure. Duct/tube/pipe 1 by its ends is connected with the upper and lower part of the water bottle of storage battery/accumulator and is established/installed vertically, next to the latter. The level of liquid bottle and the housing of apparatus is set always even one horizontal plane, as in the communicating vessels. Within the housing of apparatus (duct/tube/pipe) float 2, which carries on itself core 3 of soft iron is placed, which is moved together with the float upward along the duct/tube/pipe in proportion to the elevation of the level of liquid in the bottle. From the face to the duct/tube/pipe of housing are put on induction coils 4, arranged/located on the levels, at which it is desirable to switch equipment. With the passage of the float through the level, on which the coil is arranged/located, a change in its electrical conductivity occurs, what is initial impulse/momentum/pulse for the production of different switchings in the network/grid of the control of the pump-and-battery station. The position of coils on the height/altitude easily can be changed. Construction/design and the sizes/dimensions of the float, used in

this apparatus, they are shown in Fig. 315.

The advantages of apparatus are: the reliability of action, small sizes/dimensions, explosion-proof character, possibility of changing the controlled/inspected levels.

BOTTLES OF PUMP-AND-BATTERY STATIONS.

The bottles of the pump-and-battery stations compose the significant part of entire assembly of the equipment for press installation/setting up.

The short description of different constructions/designs of bottles and methods of their manufacture is given below.

Forged bottles. Forging cylindrical shell on the diagram, shown in Fig. 316, is the first stage in the manufacture of bottle.

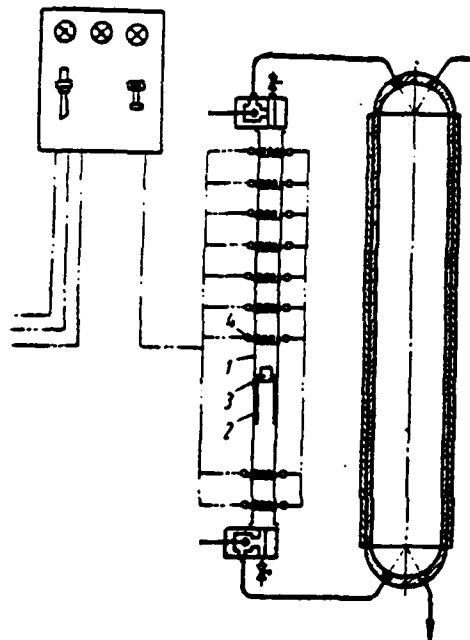

Fig. 314.

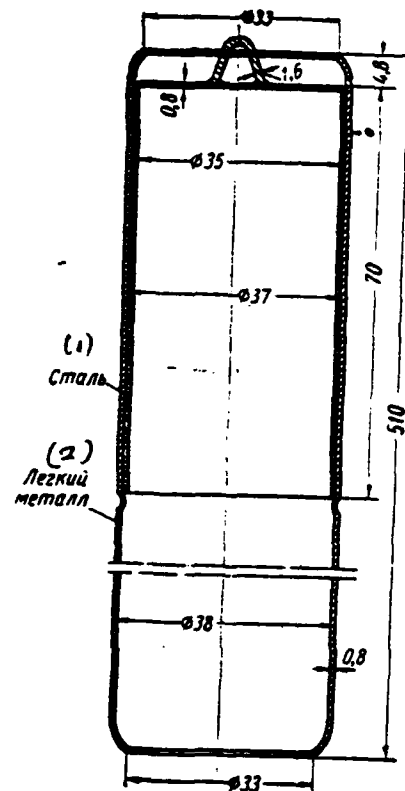

Fig. 315.

Fig. 314. Schematic of induction float apparatus for the checking of the levels of liquid in the storage battery/accumulator.

Fig. 315. Construction/design of the float of induction apparatus.

Key: (1). Steel. (2). Light metal.

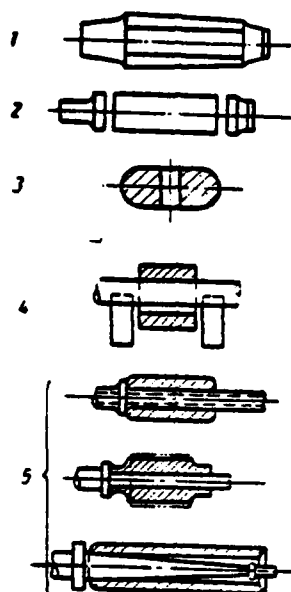

Fig. 316. The diagram of forging on the press of the cylindrical shell of the bottle: 1 - ingot; 2 - removal/distance of riser and pan/pallet; 3 - sediment/residue; 4 - upsetting on the mount/mandrel; 5 - drawing on the mount/mandrel.

Page 341.

The forged shell undergoes annealing or standardization and enters the machining.

After the machining is produced the pricking of the ends of the shell, which is produced either by common faces or faces, carried out

in form of finished cupola.

In the first case the shell is done with the thickened walls at the ends, whose pricking is produced by steps/stages. The surface of cupola in this case is uneven and it is necessary to additionally work it.

The pricking of ends in the special faces with the device, which ensures backwater and intermittent feed of shell into the die/stamp in the process of pricking (Fig. 317) is more advanced. This device relies on the axial force, which affects on the shell and the component approximately $\frac{1}{3}$, from the effort/force, developed with press. With this method of pricking the need for leaving thickening at the ends is eliminated, and the subsequent working of bottle after pricking also becomes excessive. Construction of the seamless-forged bottle, designed for pressure 320 kg/cm^2 , with the ends, begun to forge by this method, it is shown in Fig. 318.

The hammered bottles are manufactured also by welded with one transverse seam or with the welded bottoms (Fig. 319), moreover shell can be manufactured of two parts, welded with the transverse seam. This method of manufacture makes it possible to apply less powerful/thick equipment, gives less than wastes and is reduced machining. The ingots, which proceed with the manufacture of bottle,

have a considerably smaller weighing and therefore cases of the waste/reject of forgings on the defects/flaws of ingot are less frequent. The diagram of forging the bottom, welded for the shell, accepted by Uralmashzavod, it is shown in Fig. 320.

The manufacture of the bottles of ductile on the presses on the labor consumption, on the waste metal (to 50% from the ingot), on the cases of waste/reject, for reasons for the defect/flaw of ingot and in the duration of cycle (to 2 months) is least modern from the existing methods.

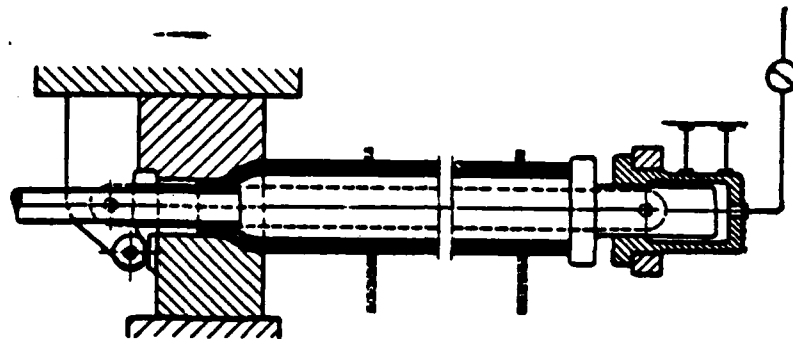

Fig. 317. Schematic of the pricking of bottle on the hydraulic press in the shaped faces.

Page 342.

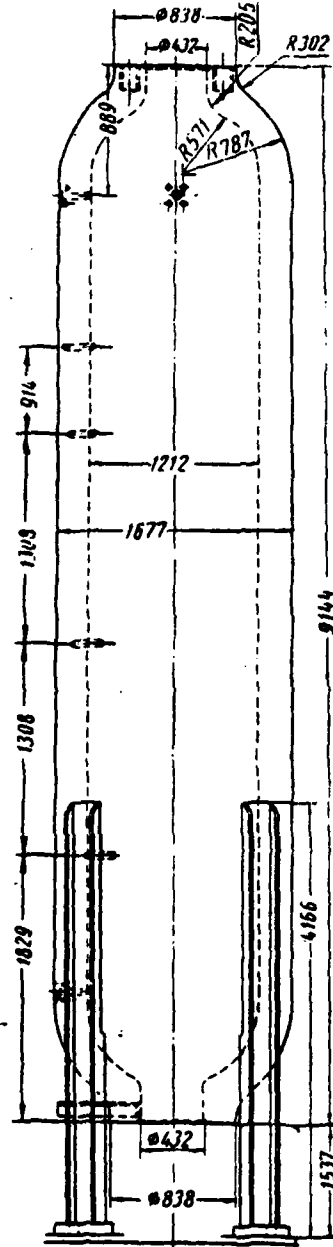

Fig. 318. Construction/design of the forged bottle, designed for pressures 320 kg/cm².

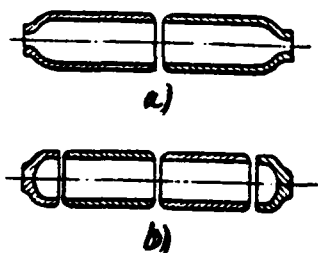

Fig. 319.

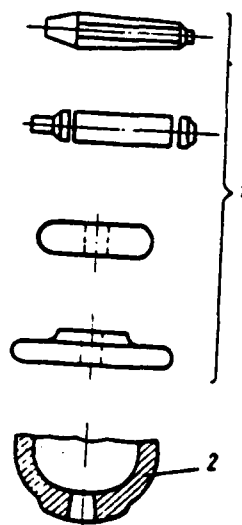

Fig. 320.

Fig. 319. Bottles: a) with the transverse seam; b) with the welded bottoms.

Fig. 320. The diagram of forging the bottom: 1 - operation of forging; 2 - bottom, obtained by stamping.

Page 343.

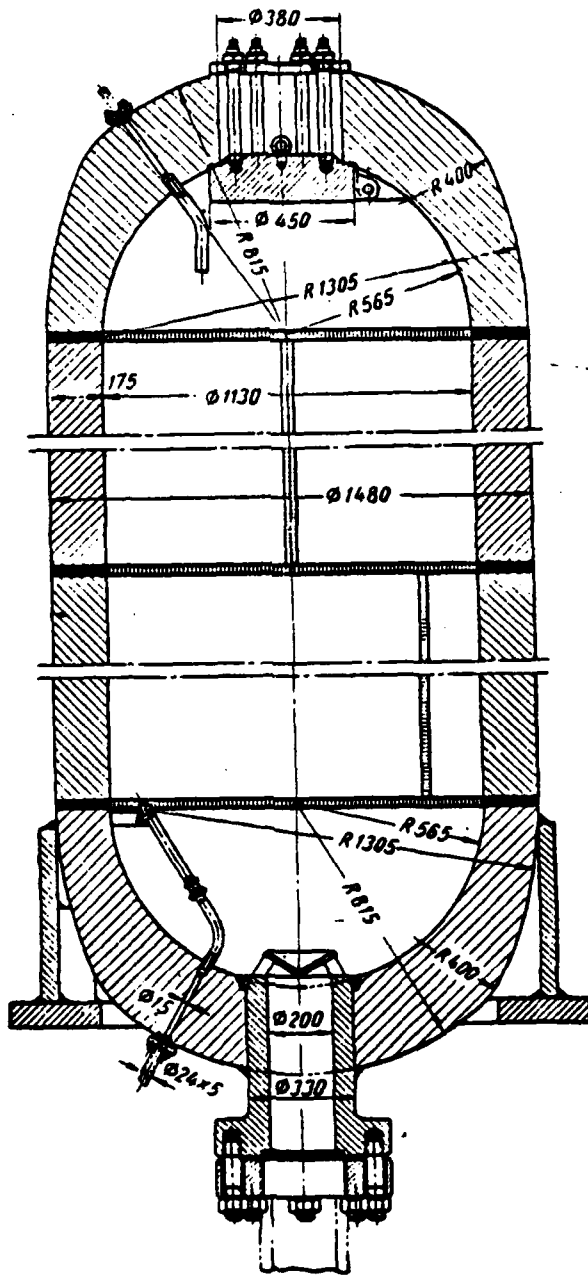

Fig. 321.

Fig. 321. Construction/design of welded bottle (from the shells, bent under the press).

Page 344.

Welded bottles from the rolled plates/slabs. Wide acceptance received the welded bottles, in which as the initial blanks for manufacturing the cylindrical shells rolled plates/slabs serve.

Thick-walled bottles. Shells from the plates/slabs by the thickness, equal to the calculated wall thickness of bottle, are manufactured either flexible on the rollers with the subsequent welding one longitudinal seam, or flexible on the hydraulic press two half-rims with their subsequent welding. The construction/design of this bottle is shown in Fig. 321.

These methods of manufacturing the bottles are more advanced in comparison with the ductile from the ingot, since waste metal considerably are reduced, is reduced by the minimum machining and cycle of manufacture shorter.

A shortcoming in the manufacture of bottles from thick plates/slabs is the need for having powerful/thick unique equipment - rollers or hydraulic press.

Multilayer bottles. Won acceptance two constructions/designs of the multilayer bottles: from the internal, relative to by the thick shell (designed for longitudinal stresses), to which were put on the short strengthened/hardened binding bands, collected from the thin-walled shells (Fig. 322), and with the cylindrical part, made from the thin-walled shells (Fig. 323).

For the production of multilayer bottles is not required unique equipment; they are manufactured great capacities (to 10 m³), which makes it possible to decrease the sizes/dimensions of pumping battery stations and simplifies their installation and maintenance/servicing.

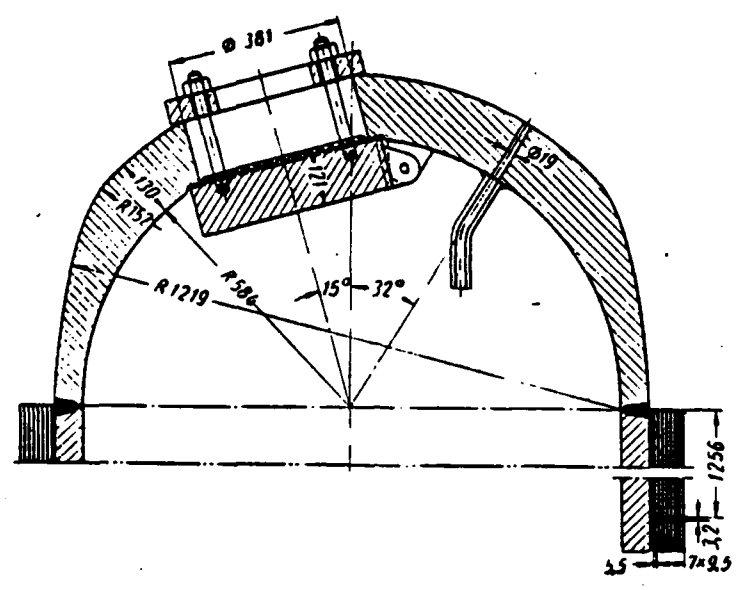

Fig. 322. Nose section of the multilayer welded bottle with the thick-walled internal shell.

Page 345.

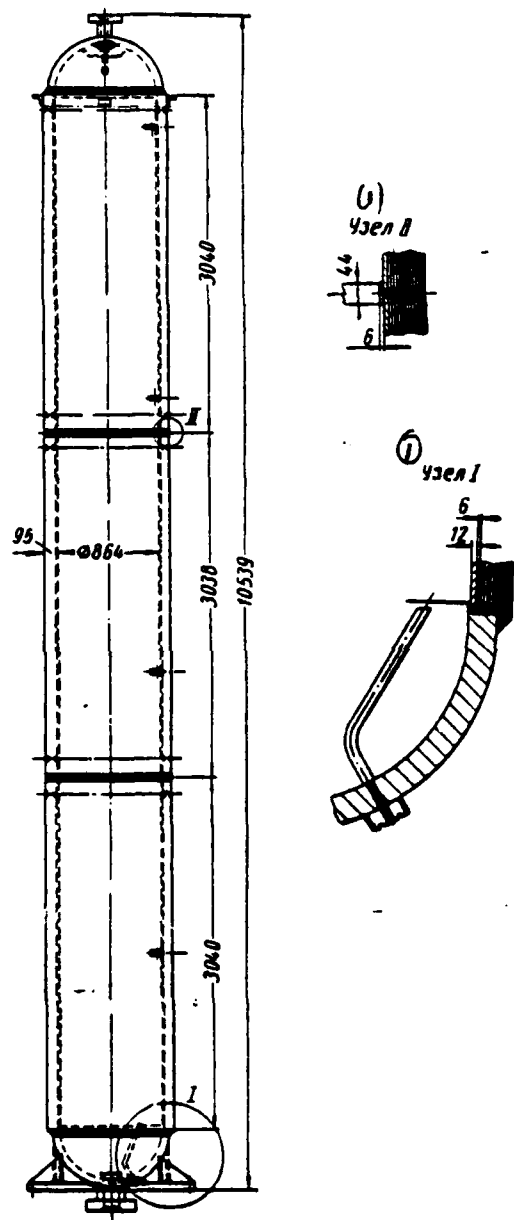

Fig. 323.

Fig. 323. Construction/design of multilayer welded bottle from the thin sheets.

Key: (1). Unit.

Page 346.

With labor consumption and cost/value of manufacture multilayer bottles are most economical in comparison with other constructions/designs and are more reliable, since to test the quality of the thin sheets it is easier than thick ones.

In the case of the emergency, caused by an excessive pressure increase, thick-walled bottle is destroyed instantly, giving a large quantity of fragments, whereas welded multilayer bottle is destroyed gradually, on separate "layers", without the formation of fragments.

Strengthened shells in these bottles are assembled without the interference and therefore bottles design just as common thick-walled.

Productive and by relatively economical is the manufacture of bottles the method of the piercing of blank with the subsequent broach through the series/row of rings and the pricking of its one

end on the special press.

The construction/design of the bottle, manufactured with this method, it is shown in Fig. 324.

A shortcoming in the method indicated is the need of applying the very powerful/thick specialized equipment. Therefore this method is applied for manufacturing the bottles of relatively small sizes/dimensions - with capacity/capacitance of up to 3.5 m³ and with an outside diameter of up to 1000 mm.

There is a method of manufacturing cylindrical shell from the poured and machined blank via its unrolling on the special mill, with the subsequent pricking of ends under the press.

This method did not thus far yet receive wide distribution as a result of the complexity of the rolling mill, relative to complicated technology of casting hollow billet and need for its machining before the unrolling.

The bottles of small amount of capacitance for the low-power pump-and-battery stations successfully are manufactured from the seamless thick-walled ducts/tubes/pipes, whose ends begin to forge on the hydraulic press or the hammer. The construction/design of storage

battery/accumulator with similar is shown by bottles in Fig. 325.

The entry of liquid into the neck of water bottle must be accomplished through special baffles for warning/preventing the formation of funnel/hopper in the liquid and fluctuations of its level.

The calculation of the flow area of neck is determined according to the equation of the continuity

$$f \cdot v = F \cdot v'$$

where f - flow passage cross-sectional area of neck;

v - velocity of liquid in the neck ($v=4-6$ m/s);

F - area of surface of liquid in the bottle;

v' - velocity of dropping liquid ($v=250$ mm/s).

The ducts/tubes/pipes of branch/removal for liquid and air, applied to equipment of the checking of the level, must be serviced directly into the bottle so that their ends would be located in the steady zone.

It is desirable to cover/coat the internal surface of bottle for warning/preventing the corrosion with asphalt.

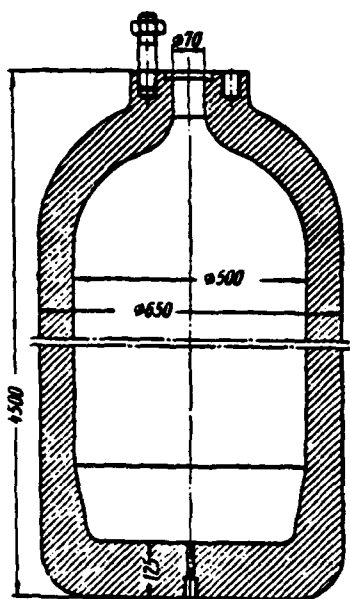

Fig. 324.

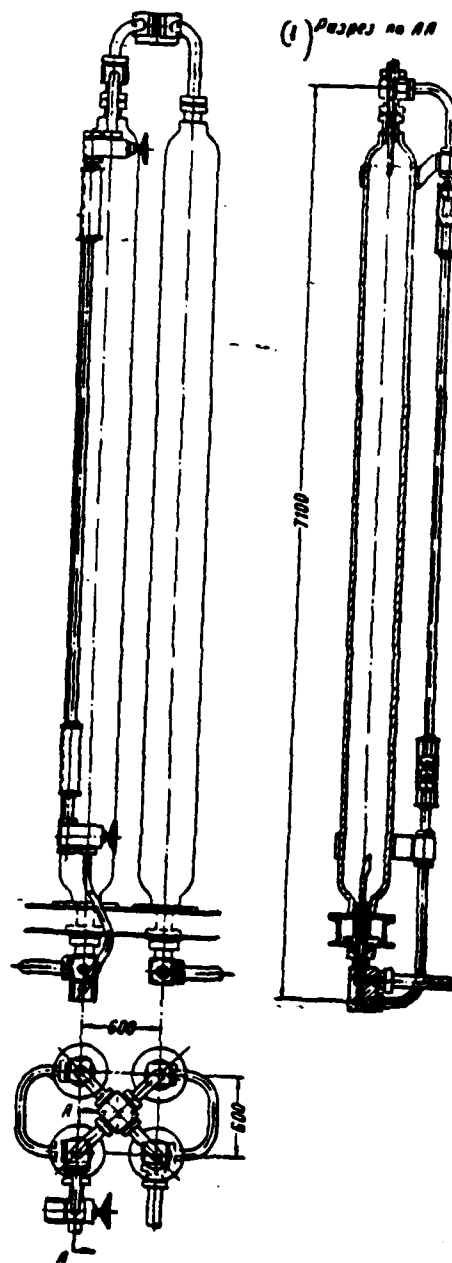

Fig. 325.

Fig. 324. Construction/design of the bottle, manufactured with the method of piercing and subsequent broach.

Fig. 325. Storage battery/accumulator, comprised of the drawn tubes.

Key: (1). Section through AA.

Page 348.

A good means, which prevents corrosion of the internal walls of water bottle, is the filling in it of oil a layer to 50 mm. With the displacement of the level the liquids in the bottle of the wall of the latter are covered/coated with oil and their corrosion is prevented/warned thus.

Welded bottles with a bore of more than 800 mm must have circular or oval accesses. Circular accesses must have a diameter not less than 400 mm, oval - the sizes/dimensions not less 300×400 mm.

Each bottle, adjusted on the station, must be equipped with the following equipment: by check valves for the cutoff/disconnection of bottle from the conduit/manifold, which supplies air or liquid; by

device for the output of the located in the bottle medium or forming in it condensate; by the operably effective manometer, equipped with adjuster next to it of the test pressure gauge, for example by three-way valve/gate; by the safety valve, adjusted to the maximally permissible operating pressure and by the equipped device, which does not make it possible for the service personnel to increase load.

The bottles of storage batteries/accumulators are manufactured from carbon or light-alloyed steel (with content of 1-1.5% of nickel). Steel must have elongation per unit length in the long samples/specimens δ_1 , not less than 1.6% and impact toughness not less than 5 kgm/cm².

The calculation of vessels is produced to the pressure according to Lame's formula. Allowable stress during the calculation is taken by equal or less than 80% of the yield point of the utilized material. For the pulled bottles with the flat bottom the wall thickness of the bottom must be 1.5-2 times of more than the wall thickness of the cylindrical part of the bottle. Finished bottles must undergo hydrostatic testing for test pressure, which exceeds working in 25%. Under test pressure the bottle must be located not less than 5 min., after which the pressure descends to the worker, with whom is produced the inspection of bottle, but for the welded bottles - knocking loose of welds by hammer with the weight of

0.5-1.5 kg the dependence of wall thickness. The lift of pressure to the test and its reduction/descent to the worker should be produced slowly. The pressure, equal to worker, is supported always, necessary for the inspection (usually to 4 hours).

Upon the appearance on the surface of the vessel of the "drops" of sweating or passage of water the bottle is recognized by that not maintained/withstood testing.

On each bottle, which works under the pressure, must it is located the metallic plate, tightly fastened on the visible place of its face side and which contains following data: 1) the designation of manufacturing plant; 2) factory serial number of vessel; 3) the year of issue; 4) the greatest permissible operating pressure; 5) the registration number of local boiler code committee.

Page 349.

Plant - producer must, furthermore, to hammer out on the thickest part of the vessel (on the branch, the flange, etc.) mark with following data:

- 1) name of manufacturing plant;

- 2) factory serial number of vessel;
- 3) the year of issue;
- 4) the greatest permissible operating pressure.

Bottles must be recorded in boiler code committee. To the statement about the recording the cord book of the established/installed sample/specimen with the recording in it of all necessary data, the log book of the bottle of plant-manufacture with the drawings of bottle and with the stress analysis of its elements/cells must be applied.

Sizes/dimensions of conduit/manifold, which connects the bottles of storage battery/accumulator..

For determining of the dimensions of the conduit/manifold, which connects air and water bottles, we will use the known formula

$$10^4 \frac{n}{n+1} \frac{p_1}{\gamma_1} \left[1 - \frac{p_2}{p_1} \frac{n+1}{n} \right] - \frac{2}{n} \cdot \frac{v_m^2}{2g} \ln \frac{p_1}{p_2} = \lambda \frac{L}{d} \cdot \frac{v_m^2}{2g}. \quad (305)$$

where p_1 and p_2 - pressures in the beginning and at the end of line in kg/cm^2 ;

v_m - average/mean rate of flow of air in the conduit/manifold in

m/s;

γ_1 - the specific gravity/weight of air at this pressure and temperature in kg/m³;

n - polytropic exponent;

L - length of conduit/manifold m;

d - bore of conduit/manifold m;

λ - drag coefficient of air flow along the duct/tube/pipe, during turbulent flow $\lambda = \frac{0.009407}{\sqrt{d}}$.

Second term on the left side of equation (305) at the common rates of flow of air (about 30-40 m/s) and small the pressure differentials is the low value, which can be disregarded/neglected.

Accepting the flow of gas the isothermal $n=1$, we will obtain

$$10^4 \frac{p_1}{2\gamma_1} \left[1 - \left(\frac{p_2}{p_1} \right)^2 \right] = \lambda \frac{L}{d} \cdot \frac{v_m^2}{2g}. \quad (306)$$

Entering the bottle air replaces the liquid, expended from the storage battery/accumulator:

$$d^2 v_m \frac{\gamma_1}{\gamma_2} = D^2 v, \quad (307)$$

where D - diameter of water bottle;

v - velocity of lowering the level of liquid in the storage battery/accumulator;

γ_1 - the specific gravity/weight of water at this pressure in kg/m^3 .

Page 350.

From equation (306), substituting in it value λ and v_m from equation (307), we find

$$d^{\frac{16}{3}} \approx \frac{0.009407LD^4v^2\gamma_1^2}{g \left[1 - \left(\frac{p_2}{p_1} \right)^2 \right] \rho_1 \gamma_1 \cdot 10^4}$$

Let us designate $p_2/p_1 = m$ and will substitute into this expression value of g ; we will obtain

$$d^{\frac{16}{3}} \approx \frac{0.00095LD^4v^2\gamma_1^2}{(1 - m^2) \rho_1 \gamma_1 \cdot 10^4} \quad (308)$$

During the computation of the bore of conduit/manifold according to this expression p_1 it can be accepted equal to the maximum pressure of liquid in storage battery/accumulator, and $m=0.95$.

Then for the pump-and-battery stations with the nominal pressure $p=200 \text{ kg/cm}^2$ and 10% drop in the pressure of liquid expression (308)

will take the form

$$d^{\frac{16}{3}} \approx 2L \cdot D^4 v^3 \cdot 10^{-6}. \quad (309)$$

For the pump-and-battery stations with nominal pressure $p = 320$ kg/cm² and 10% drop in the pressure of the liquid

$$d^{\frac{16}{3}} \approx 0,8L \cdot D^4 v^3 \cdot 10^{-6}. \quad (310)$$

Page 351.

Chapter 7.

HYDRAULIC SYSTEMS, DISTRIBUTORS AND EQUIPMENT.

Filler systems of presses.

General information.

For the filling with the liquid of working cylinders, during the idling of cross-beam, most frequently apply the accumulators of low pressure, called filler tanks.

In the filler tank it stored up working fluid they take as equal to 2-2.5 complete volumes of working cylinders.

The large reserve of liquid in the filler tank, in comparison with a maximally possible consumption by its press for one course, is justified by the fact that in this case is not required the checking of the level of liquid, since the tank cannot be emptied completely and, furthermore, with the large volume in the hydraulic system of liquid it not so intensely is heated, into therefore the cooling

installations they make low powers or they bypass completely without them.

The pressure of liquid in the tank, created by the compressed air, depending on the prescribed/assigned idling speed of movable cross-beam, is selected equal to 4-8 kg/cm². The greater the pressure of liquid in the filler tank, the less sizes/dimensions have filler valve and conduit/manifold, which connects tank with the cylinder. However, during the selection of pressure it is necessary to keep in mind that it affects the value of the effort/force of recurrent pressure cylinders, since the liquid of the working cylinders is squeezed out by pull-backs into the filler tank with the recurrent course of the crosshead. They take air pressure at the end of the period of the filling of working cylinder as the equal to 70-75% of the initial. The selection of pressure in the filler tank, and also the sizes/dimensions of filler conduit/manifold and valve is critical task during the design of press, since during the incorrect solution the most incomplete possible filling of cylinders for the lost motion time, which negatively affects the work of press.

Filler tanks place near the press or on its upper cross-beam.

During the arrangement of tank on the cross-beam filler conduit/manifold has small length, as a result of which the hydraulic flow resistance of liquid is small. In this case the tanks are frequently made opened, i.e., liquid in them is located under the atmospheric pressure.

The installation/setting up of tanks on the press causes an increase in its height/altitude, a higher arrangement of the center of gravity, as a result of which the stability deteriorates. This is a shortcoming in this mounting method of tank. Therefore this method is applied mainly for the slow presses with the pumping batteryless drive. The crosshead of press has the maximum velocity during the idling, when working cylinders are filled with low-pressure liquid from the filler tank. Filler conduit/manifold has considerably large cross sections in the comparison with the pressure piping, and therefore it is usually laid by separate branch for entire elongation/extent from the tank to the working cylinders.

Fittings of filler tank consists of the safety air valve, level indicator of working fluid in the tank (the gauge glass) and of shutoff valves on the feed lines and issue of the compressed air and working fluid.

On the line, which connects filler tank with the press, in the

case of repairing the latter are set the special check valves, which in the closed position work as check valves, i.e., they give the possibility of free pass of liquid from the press into the tank, which excludes possibility of designing of high-pressure in the filler line with the closed valve and the start in this case of press to the recurrent course.

The extended constructions/designs of such check valves it is shown in Fig. 326 and 327.

The hydraulic schematic of press can be constructed either with the circulation of liquid according to the closed conduit/manifold or with its breakage in the pressure tank, which feeds pumps.

In the first diagram the pumps take away/gather liquid from the filler tank and is supplied it into the press or storage battery/accumulator. Entire/all liquid from the press in this case is drawn off into the filler tank. This diagram is applicable mainly when press is given from the individual pumping or pump-and-battery station.

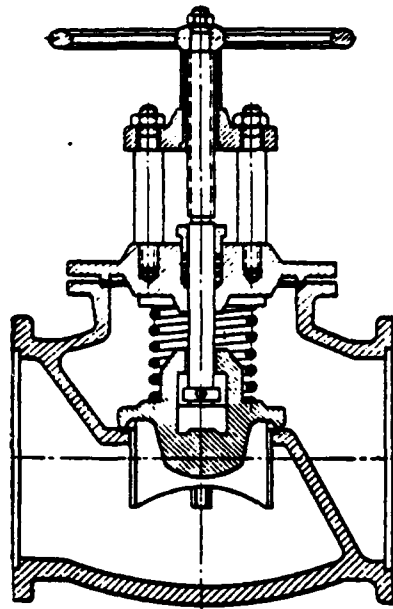

Fig. 326. Check valve with the spring.

Page 353.

Its use/application can prove to be advisable also when group-presses are serviced by one pumping plant, it is sufficient distant from them, but each press has the individual, closely spaced to it storage battery/accumulator. In this case the conduits/manifolds of filler tanks must be rung.

During the circulation of liquid on the closed conduit/manifold are unavoidable its losses from the system due to the leaks/leakages

in the controls, and also through the cylinder sealings/packings/compactions.

For completing/adding the leaks/leakages in the hydraulic system it is necessary to have a pump, which is included periodically for completing/adding the filler tank. In the presses with the batteryless pumping drive, which work on mineral oil, this tank usually is utilized for the collection of the leaks/leakages of oil through valves and valves of control.

Hydraulic diagrams with the pressure tank in the pumping plant received preferred propagation. On this diagram of bleedings from the cylinders, not consuming liquid from the filler tank, can be accomplished/realized into the pressure tank of pumping plant. Bleeding from master cylinders is produced only into the filler tank so that in it the fixed level would be supported. But since in each cycle of the work of press into the tank it is drawn off liquid large by the value, supplied with pumps or pump-and-battery station, by which from it it takes away/gathers, filler tank must be equipped with valve for jettisoning the excessive liquid into the tank of pumping plant. For the overflow of liquid are applied either the float valves, one of constructions/designs of which is shown to Fig. 328, or safety valves with the spring or cargo loading (Fig. 329). Safety float valves are more reliable and do not cause the

fluctuation of the level of liquid in the tank with the leaks/leakages from it of the compressed air.

In the presses of relatively low powers frequently instead of the filler tanks are applied the low-pressure pumps - gear, blade or centrifugal.

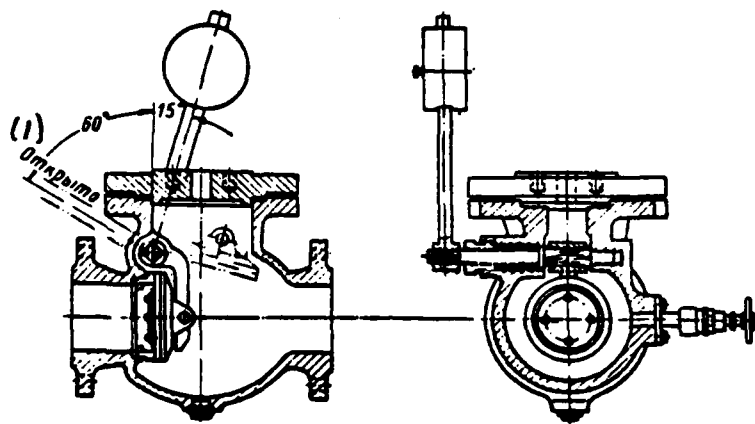

Fig. 327. Check valve with the load.

Key: (1). Opened.

Page 354.

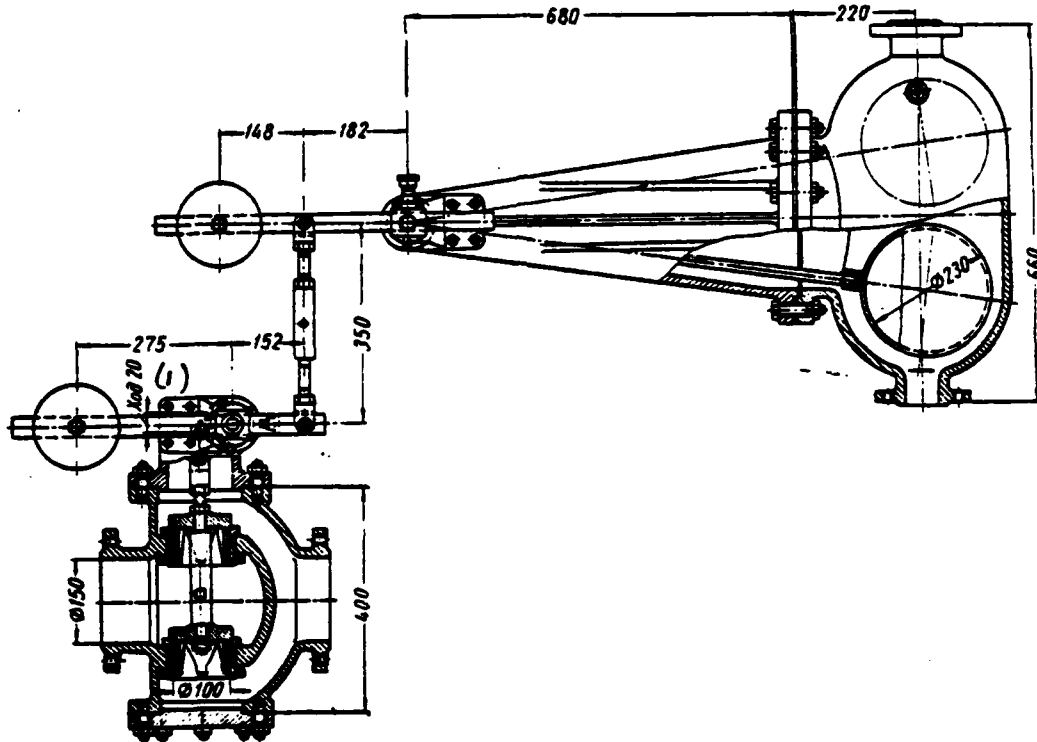

Fig. 328. Overflow float valve.

Key: (1). Course.

Page 355.

In this case in the line, which goes from the reverse/inverse cylinders, the support valve, designed for the pressure, which is created in the pull-backs from the weight of the moving elements of the press, is established. The schematic diagram of filler system of press with the pump-and-battery drive is shown in Fig. 330.

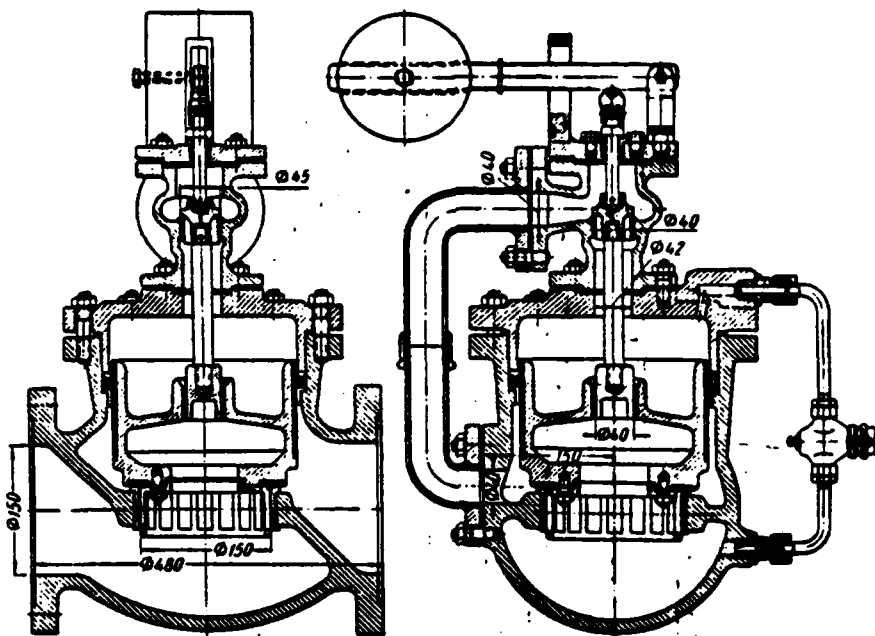

Fig. 329. Overflow valve with the cargo loading.

Determination of the capacity/capacitance of filler tank and diameter of filler conduit/manifold.

Accepting the incidence/drop in the air pressure in the tank according to the law of $pQ = \text{const}$, its volume we determine from the formula

$$Q > \frac{\left(\kappa + \frac{n}{1-n}\right) FS}{1000}, \quad (311)$$

where κ - ratio of the volume of liquid in the tank to the complete volume of working cylinders ($\kappa = 2-2.5$);

n - ratio of final pressure in the filler tank to initial pressure ($n=0.7-0.75$);

F - total area of working cylinders in cm^2 ;

S - complete course of working plungers in cm.

The section/cut of filler conduit/manifold is selected from the condition of obtaining in it the rate of flow of liquid 2.5-7 m/s, moreover high values are taken with the short conduits/manifolds.

filler tank - compensator; 4 - shutoff valve with the one-sided passage of liquid in the closed state; 5 - pet valves; 6 - locking air valves/gates; 7 - safety air valve; 8 - filler tank; 9 - shutoff valve; 10 - liquid level gauge; 11 - manometer; 12 - safety valve; 13 - overflow valve; 14 and 15 - catch; 15 - shutoff valve.

Key: (1). Air. (2). To the valve distributor. (3). Supply of liquid. (4). To the drain. (5). To the storage battery/accumulator. (6). Drain from the press. (7). In the pressure tank of pumping plant.

Page 357.

The selection of the low speed of liquid in the conduit/manifold is explained by the fact that with the sharp stop of the crosshead at the very beginning of its course, when in the cylinder is a relatively small amount of liquid, is feasible hydraulic impact.

In the case of the filler conduit/manifold of large length, to avoid the emergence of the hydraulic impact of large force, and also the appearances of negative pressure in the working cylinder, on the conduit/manifold install intermediate baths - the compensators, the part of volume of which is filled with the compressed air.

The capacity/capacitance of filler tank during the

installation/setting up on the filler conduit/manifold of compensator, and also the capacity/capacitance of compensator itself are determined by the following approximate computation (Fig. 331).

Required pressure p_* in the compensator at the end of the idling of the crosshead is determined from the equation of the steady motion, written for the conduit/manifold, which connects compensator with the working cylinder. Disregarding a difference in the levels of liquid in the compensator and the cylinder and assuming/setting pressure in the cylinder by equal to zero, we will have

$$10p_* \approx \frac{v_{m_1}^2}{2g} \left(1 + \lambda_1 \frac{L_{m_1}}{d_{m_1}} \cdot 10^3 \right), \quad (312)$$

where L_{m_1} - length of conduit/manifold m;

v_{m_1} - rate of flow of liquid in the filler conduit/manifold in the m/s²;

d_{m_1} - diameter of conduit/manifold in cm.

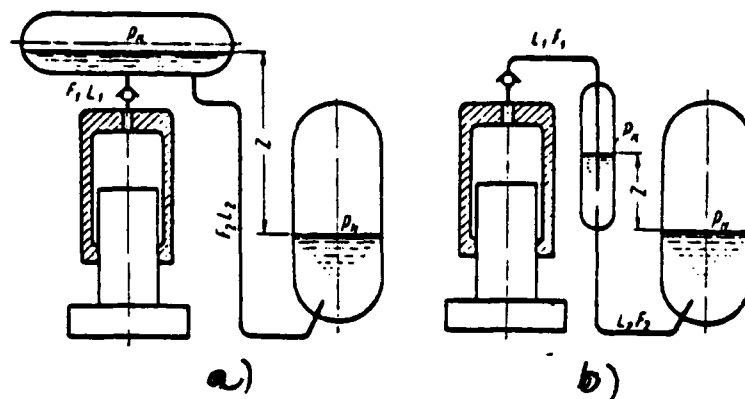

Fig. 331. Diagrams of the layout of the compensators: a) on the cylinder; b) on the conduit/manifold.

Page 358.

Pores to the equation of the continuity

$$v_{m_1} = \frac{D^2}{d_{m_1}^2} u \cdot 10^{-2},$$

where D - diameter of working cylinder in cm;

u - velocity of the crosshead in cm/s^2 .

Substituting expression v_{m_1} in equation (312), we will obtain

$$10p_n \approx \frac{10^{-4}}{2g} \cdot \frac{D^4}{d_{m_1}^4} \left(1 + \lambda_1 \frac{L_{m_1} \cdot 10^2}{d_{m_1}} \right) u^2. \quad (313)$$

Analogously is determined required pressure in the filler tank

at the end of the idling:

$$10p_n = 10p_k + Z + \frac{10^{-4}}{2g} \cdot \frac{D^4}{d_{m_1}^4} \left(1 + \lambda_2 \frac{L_{m_2}}{d_{m_1}} \right) u^3.$$

For simplification in the calculation we assume/set Z equal to an initial difference in the levels in the filler tank and the compensator.

For the state of rest in the beginning of the motion of mobile crosshead we have a relationship/ratio

$$\frac{p_n}{n} = \frac{p_k}{m} + \gamma Z, \quad (314)$$

where n and m - ratio of final pressure to the initial ones respectively in the filler tank and in the compensator.

From equation (314), having assigned the pressure differential in the filler tank, we determine value m.

Let us assign the initial volume of air in compensator Q_0^k . Then the maneuvering volume of the liquid of compensator composes

$$Q_{\Sigma}^k = Q_0^k \left(\frac{1-m}{m} \right) \quad (315)$$

and the total volume of compensator Q^k

$$Q^k > Q_{\Sigma}^k + Q_0^k = \frac{Q_0^k}{m}. \quad (316)$$

The maneuvering volume of liquid in filler tank Q_{Σ}^n will be determined from the expression

$$F \cdot S - Q_{\Sigma}^k = Q_{\Sigma}^n. \quad (317)$$

We further find the initial volume of air in filler tank Q_0^a :

$$Q_0^a = Q_x^a \left(\frac{n}{1-n} \right). \quad (318)$$

Filler valves.

The extended constructions/designs of the filler valves, used in the presses with pump-and-battery drive, are shown in Fig. 332 and 333.

Page 359.

Valves usually are installed on the working cylinders and only in the rare cases in one unit with the basic control valves of press. In the latter case the conduit/manifold in the section from the control unit of press to the working cylinders serves for the supply of the liquid both of high and low pressure, and therefore its section/cut is designed from the fluid flow rate during the idling, and wall thickness - to the high pressure.

In the forging presses with steam-air multiplier filler valve works relatively rarely, i.e., only if the solution/opening between the faces is changed or working stroke for several courses of multiplier is accomplished/realized, and therefore to more expediently install them near the filler tank.

In the presses with the pumping batteryless drive, which work on mineral oil, filler tanks and valves usually install directly on the working cylinders (filler valve within the tank).

One of the constructions/designs of filler valve for such presses is shown in Fig. 334.

For the opening of filler valves with the bleeding from the working cylinders into the filler tank during the recurrent course of the crosshead on the valve body the auxiliary cylinders, connected to the line, which feeds reverse/inverse cylinders, are installed.

For the purpose of the facilitation of valve opening, i.e., the decreases of sizes of auxiliary cylinder, filler valves supply with additional relief valves of small section/cut.

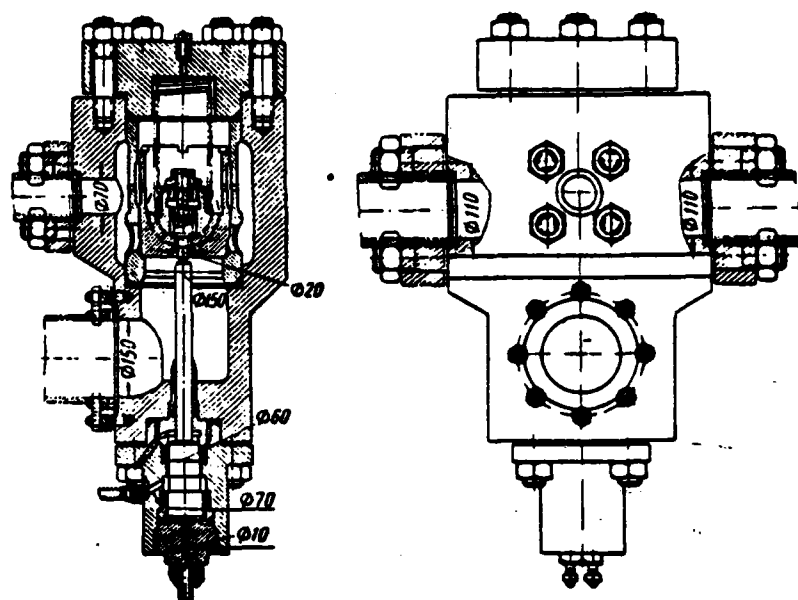

Fig. 332. Extended construction/design of filler valve.

Page 360.

The effort/force of auxiliary cylinder, and also flow areas in the valve (from the cylinder into the cavity above valve and from this cavity with the drain line through relief valve) must be calculated, accepting relatively small pressure in the cylinder, with which the bleeding on the filler conduit/manifold without a considerable increase in it in the pressure, which is spread from the working cylinders, is feasible.

When the motion of mobile crosshead during the idling is accomplished/realized by the auxiliary cylinder, fed from the pump, cross-beam quick-to-accelerate to maximum in the beginning of stroke, apply the valves, held opened by spring during the idle and return strokes of crosshead and closing under pressure of oil from the pump. The construction/design of this valve is shown in Fig. 335.

The flow area of valve they calculate according to the assigned idling speed of the crosshead and the rate of flow of liquid adopted in the filler valve:

$$f = F \frac{v_1}{v_2}$$

where f - flow area of filler valve;

F - area of the plunger of the cylinder, whose filling occurs through the designed valve;

v_1 - the maximum speed of mobile crosshead during the filling;

v_2 - rate of flow of the liquid through the valve, determined from the equation

$$v_2 = \varphi \sqrt{2gH}.$$

where H - maximum pressure in the filler tank in m H₂O;

φ - speed factor, taken for the filler valves to the approximately equal to 0.3.

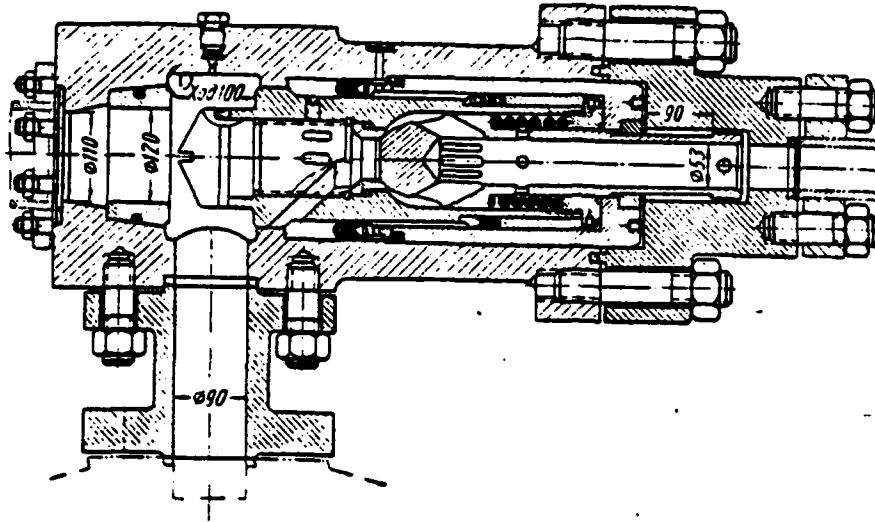

Fig. 333. Extended construction/design of filler horizontal valve.

Key: (1). Course.

Page 361.

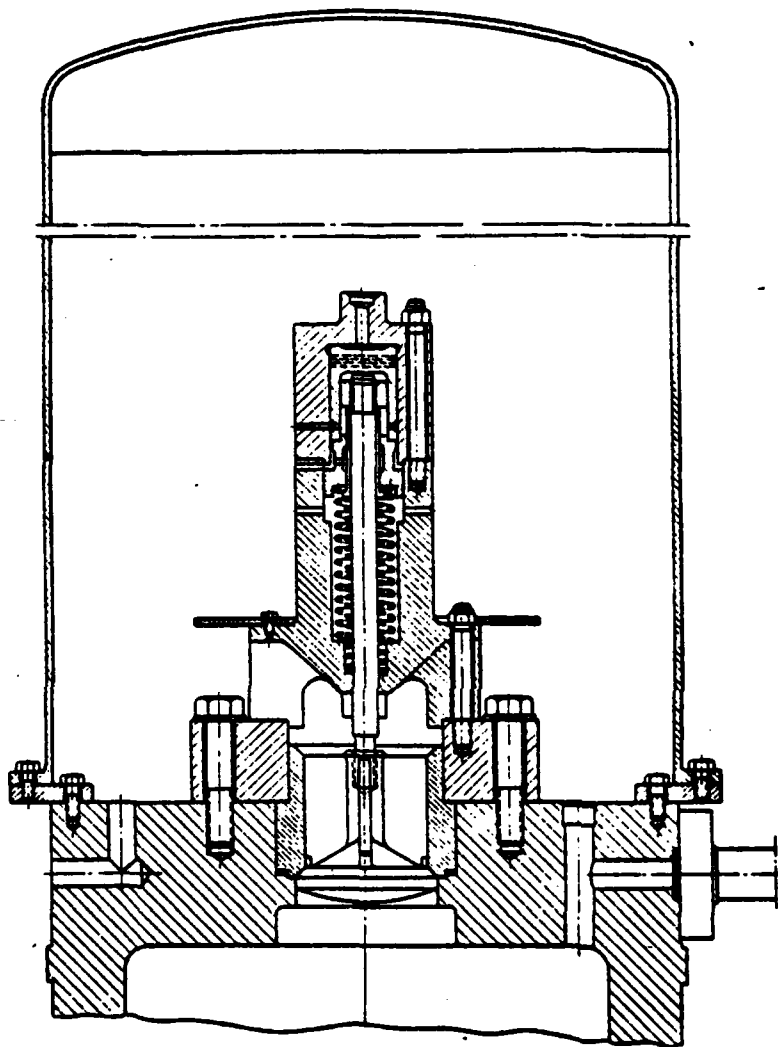

Fig. 334. Construction/design of filler valve for the press with the individual pumping drive.

Page 362.

Velocity v_1 is not recommended to accept more than 7 m/s. For the high-speed presses during the calculation of valves they use also relationship/ratio [27]:

$$f = 0.05F + 20 \begin{matrix} (1) \\ \text{при рабочем давлении } 400 \text{ кг/см}^2 \end{matrix}$$

$$f = 0.05F + 40 \begin{matrix} (2) \\ \text{при рабочем давлении } 200 \text{ кг/см}^2 \end{matrix}$$

Key: (1). at the operating pressure. (2). -kg/cm².

Over section/cut of valve determined thus is selected the section/cut of filler conduit/manifold.

The given calculations should be used during the first stage of the design, when the geometric dimensions of entire filler line are not yet determined. With its refinement it is necessary to manufacture the verifying calculation of the dynamics of the idling (see Chapter 4) and, if it proves to be necessary, to correct the sizes/dimensions of valve and conduit/manifold accepted.

The effort/force of auxiliary cylinder for the discovery/opening of filler valve is relied on the pressure, equal to 3-4—fold maximum pressure in the filler tank:

$$D = D_n \sqrt{\frac{(3+4) p_{\text{max}}}{p}}$$

where D - working diameter of the plunger (piston) of auxiliary cylinder;

D_v - diameter of filler valve;

$p_{v \max}$ - maximum pressure in the filler tank;

p - operating pressure in the line of pull-backs.

The flow passage cross-sectional area of relief valve f_1 (Fig. 332) must be somewhat more than the area of holes f_2 , which connect over-valve cavity with cylinder $f_2/f_1=0.8-0.85$.

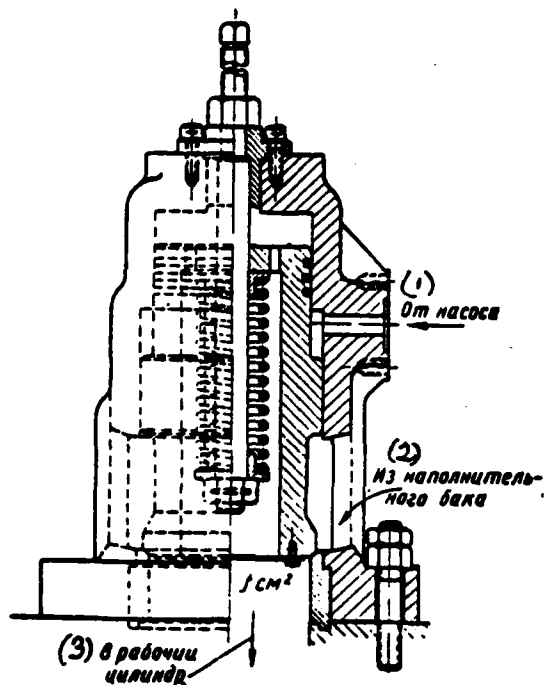

Fig. 335. Filler valve, which is closed by the oil pressure of the forcing line of working cylinder.

Key: (1). From the pump. (2). From the filler tank. (3). To working cylinder.

Page 363.

Calculation of overflow line.

Per cycle of the work of press an excessive quantity of working fluid, which enters the filler tank, is equal

$$\sum_{i=1}^{i=m} F_i S_i$$

where m - number of cylinders, from which the bleeding into the filler tank occurs;

$F_i S_i$ - volume of the liquid, which comes the cylinder from pump or pump-and-battery station per cycle of the work of press, cm^3 .

The drain of this amount of liquid from the filler tank must be produced for the time of one cycle of the work of press (T). For simplification in the calculations, and also for the larger reliability for the design pressure in the filler tank we accept its mean pressure in the cycle:

$$p = \frac{p_{\text{max}} + p_{\text{min}}}{2}.$$

It is possible to disregard the fluctuation of the level of liquid in the pressure tank of pumping plant and as the calculated to accept its upper level, calculating the latter from the lower level of liquid in filler tank H_{ns} .

The equation of the steady motion of liquid along the conduit/manifold, if we disregard/neglect velocity head, will take the form

$$10p - H_{\text{ns}} = \frac{100v^2}{2g} \cdot \frac{\lambda L}{d},$$

where L - length of overflow conduit/manifold m , including the length

of the duct/tube/pipe, the losses by which are equivalent to local losses on the line of overflow conduit/manifold;

d - bore of overflow conduit/manifold in cm;

v - rated speed of liquid in the overflow conduit/manifold in m/s;

λ - drag coefficient of line.

The second calculated equation will be

$$10^{-3} \sum_{i=1}^{i=m} F_i S_i = v \frac{\pi d^3}{4} T.$$

From these equations, knowing the reduced length of the overflow conduit/manifold L (its geometry and the characteristic of the fittings adjustable on it), we find the diameter of the overflow conduit/manifold:

$$d = \sqrt[3]{\frac{\left(\sum_{i=1}^{i=m} F_i S_i\right)^2 \lambda L \cdot 8}{10^3 (10p - H_{\text{red}}) T^2 \cdot g}} \quad (319)$$

Page 364.

HYDRAULIC SYSTEMS OF PRESSES WITH PUMPING BATTERYLESS DRIVE.

During the pumping batteryless drive the plunger pumps mainly

working on mineral oil are applied. The feeding of these pumps is expedient to accomplish/realize from the filler tank, in which oil is under pressure, since in this case their good filling during the suction is provided.

Use as the working fluid of mineral oil gives the possibility for the control of presses to apply distributors simple by the construction/design with the valves, for displacement of which small efforts are required. Flowed away oil from the system through pump and control devices must be assembled into the open (without the pressure) tanks, from which it periodically must be pumped over into the filler tank.

The hydraulic schematics of presses, depending on designation/purpose and power of the latter, have different performances. It is necessary to note the most general considerations, which must be considered during the construction of diagram. On the forcing line of pump, to the valves of control must be established/installed the reliably effective safety valve, whose throughput capacity at maximum pressure in the system must be equal to the complete supply of pumps.

Safety valve in the majority of the cases must be also placed on the line of pull-backs after the valve of control in order to

eliminate possibility of designing of high-pressure in them by the effort/force of working cylinders. Slide-valve distributors do not provide the dense overlap of lines, and therefore in the powerful/thick vertical presses on the conduit/manifold of pull-backs the controlled saddle-like valve frequently is established/installed, which overlaps conduit/manifold to the period of the stop of the crosshead in the upper position. In the presses of low power during the use/application for idle throw of plump of low-pressure, which feed working cylinders, or auxiliary cylinder, fed from the basic high-pressure pump, instead of the controlled valve check and support valves are established/installed. In this case the support valve, through which the oil drain from the pull-backs occurs, must be opened/disclosed at a pressure in the line, somewhat larger than the pressure, created by the weight of the moving elements of the press. In order to eliminate the propagation of pressure jump from the working cylinders on the discharge lead, during switching of press to the recurrent course, it is necessary on the conduit/manifold of working cylinders to establish/install relief valve with small flow area, which must be opened/disclosed and depressurize in the working cylinders to switching of valve on the recurrent course.

Opening and closing of control apparatuses of press must be accomplished/realized in such sequence that in the forcing line of pump would not be created the high pressure, when pump was not

connected with the cylinder.

Page 365.

In the time of pauses in the work of press must be provided the free pass of oil from the pump into the tank, from which it feeds. In the press it is necessary to provide for terminal switches for the cutoff/disconnection of pull-backs from the forcing line of pump in the end upper (and for the horizontal presses - rear) position of the crosshead. In delivery conduits it is necessary to establish/install manometers for the observation of a change of the pressure in the system. Rotary pumps can work only on pure/clean (not contaminated) oil and therefore it must constantly be filtered. Since mineral oils depending on temperature change their viscosity and have relatively low flash point, in the hydraulic system it is necessary to provide for coolers for maintaining the constant temperature of oil. The rate of flow of oil in the conduits/manifolds should be selected as far as possible low, not above 6 m/s in forcing lines and 4-4.5 m/s in the drain ones.

The hydraulic schematic of powerful/thick stamping machine, which includes the elements/cells indicated, it is shown in Fig. 336.

In the presses with several steps/stages of velocities and

efforts/forces, obtained due to the start of different number of cylinders, as the impulses/momenta/pulses for switching of press from one step/stage to another the pressure in the system is utilized. On the forcing line in this case by the pressure relay, which the valves, which consecutively/serially connect additional working cylinders, operate/wear are established/installed.

The simplest schematic of the three-cylinder press with the electric control, which works with two steps/stages of efforts/forces and velocities, it is shown in Fig. 337.

At first stage oil from pump 2 through valve 4 comes only into one pitch cylinder. Valve 8, which connects forcing line with the outer cylinders, is closed. Their feeding occurs from the prefiller. With the pressure increase in the pitch cylinder to the maximum the pressure relay 10, which affects valve 8, operates/wears. The latter is opened/disclosed, and oil from pump comes into all three cylinders. On the same diagram the presses with three steps/stages of efforts/forces and velocities can be constructed.

During the use of several pumps of different characteristics for the consecutive cutoff/disconnection of pumps from the working cylinders the valves or the valves, which operate/wear from the pressure in the forcing line, are applied.

In many instances it is necessary to support certain time pressure in the working pressure cylinder at the fixed plunger. This need is, for example, in the punch presses with several crossheads or sliders for the clamp of blank by vertical slider, with bending-under of the edges of sheet horizontal slider, in the presses for rubber-pad forming, in the presses for the extrusion/pressing of plastics and so forth, etc. During the use/application of rotational-plunger pumps with the adjustable supply the maintenance of pressure in the system can be accomplished/realized by an installation/setting up of the unit of pump to the supply, which compensates for leaks/leakages from the hydraulic system, only.

Page 366.

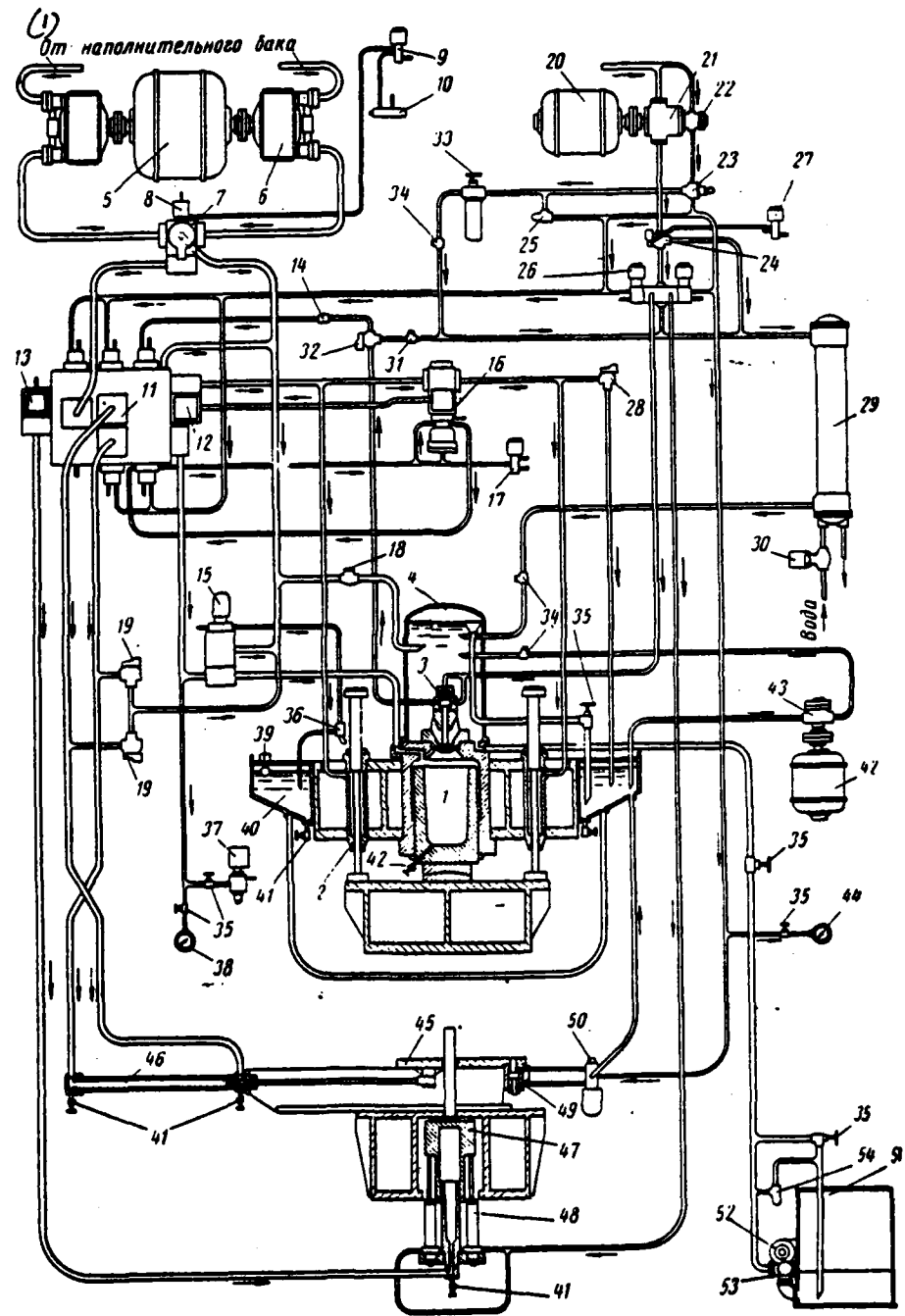

Fig. 336.

Fig. 336. The hydraulic schematic of press by effort/force 2000 t: 1 - working cylinder; 2 - cylinders of recurrent course; 3 - filler valve; 4 - filler tank; 5 - main electric motor with a power of 147 kW; 6 - Rotational-plunger pump with the supply 250 l/min, the pressure 200 kg/cm²; 7 - safety valve; 8 - valve, which gauges ultimate pressure in the system; 9 - auxiliary, controlled by electromagnet valve; 10 - the pilot valve, adjusted on the control panel for regulation of ultimate pressure in the system; 11 - slide-valve distributor; 12 and 13 - check valves; 14 - choke/throttle; 15 - relief valve; 16 - locking (saddle-like) valve of pull-backs; 17 - auxiliary, controlled by electromagnet drain valve; 18 - check valve; 19 - safety valves to the pressure 100 kg/cm²; 20 - electric motor with the power of 18.4 kW, auxiliary hydraulic system; 21 - rotary pump with the supply 116 l/min; 22 - rotary pump with the supply 35 l/min; 23 - safety valve to the pressure 31.5 kg/cm²; 24 - safety valve to the pressure 70 kg/cm²; 25 - safety valve to the pressure 35 kg/cm²; 26 - fourway valve with electromagnetic control; 27 - auxiliary drain valve electromagnetic; 28 - safety valve to the pressure 200 kg/cm²; 29 - cooler; 30 - check valve, controlled by thermostat; 31 - check valve; 32 - safety valve to the pressure 18 kg/cm²; 33 - filter for oil; 34 - check valves; 35 - shutoff valves; 36 - hydraulic terminal switch; 37 - pressure relay; 38 - pressure gauge; 39 - float switch for the checking of oil

level; 40 - tanks for the collection of the leaks/leakages of oil; 41 - drain valves; 42 - electric motor with a power of 3.6 kW; 43 - gear pump with the supply 470 l/min; 44 - manometer; 45 - extensible table; 46 - cylinder of extensible table; 47 - cylinder of knockout; 48 - the pull-backs of knockout; 49 - cylinder of the clamping fixture of table; 50 - valve of control of the clamping fixture of table; 51 - storage tank of oil; 52 - electric motor with a power of 7.3 kW; 53 - gear pump with the supply 378 l/min; 54 - safety valve.

Key: (1). from the filler tank.

Page 367.

However, this solution is irrational during the use/application of the powerful/thick pumps, leaks/leakages in which are sufficiently great.

For maintaining the pressure in the cylinder without the motion of plunger it is expedient to establish/install the additional pump of fine feed. The hydraulic schematic of punch press with booster pump of fine feed for maintaining the pressure in the working cylinders with the fixed cross-beam is shown in Fig. 338.

When press works without the holding of pressure in the working

cylinder, oil from booster pump 11 circulates without the pressure through the opened in this time valve 12. Upon the start of press to the work with the holding of pressure valve 12 is closed and booster pump together with the basis during the working stroke supplies pressure oil in the working cylinder. At the end of the working stroke of the crosshead, during the switching with the aid of the slide-valve distributor of 3 basic oil pumps into the horizontal cylinder, vertical cylinder continues to feed from one booster pump; in this case the excess of oil is thrown off through safety valve 12. The pressure, necessary for the clamp of blank, is regulated by safety valve and can be established/installed greater or smaller in comparison with the pressure, developed with basic pump.

In the punch presses with two crossheads (presses of double action) the pressure in the cylinders of external cross-beam can be supported with the aid of the auxiliary cylinders, whose plungers are fastened on the internal crosshead, and the throttle valve, set to the requiring pressure.

This hydraulic diagram is shown in Fig. 339.

Page 368.

With the work of several cylinders, which feed from one pump,

frequently it is necessary to ensure the specific sequence of moving the plungers. For example, in the press with the hydraulic diagram, shown in Fig. 338, it is necessary that the horizontal crosshead could not be connected during the motion of vertical cross-beam. This sequence of moving the cross-beams is accomplished/realized due to the use/application for the control of the vertical cylinder of slide-valve distributor 3 with the free pass of oil in the neutral position of valve and the connection of the passage channel of this distributor with the lead-in channel of slide-valve distributor 5, which controls horizontal cylinder.

With this connection of valves the possibility of oil feed into the horizontal cylinder during the motion of main cross-beam is eliminated.

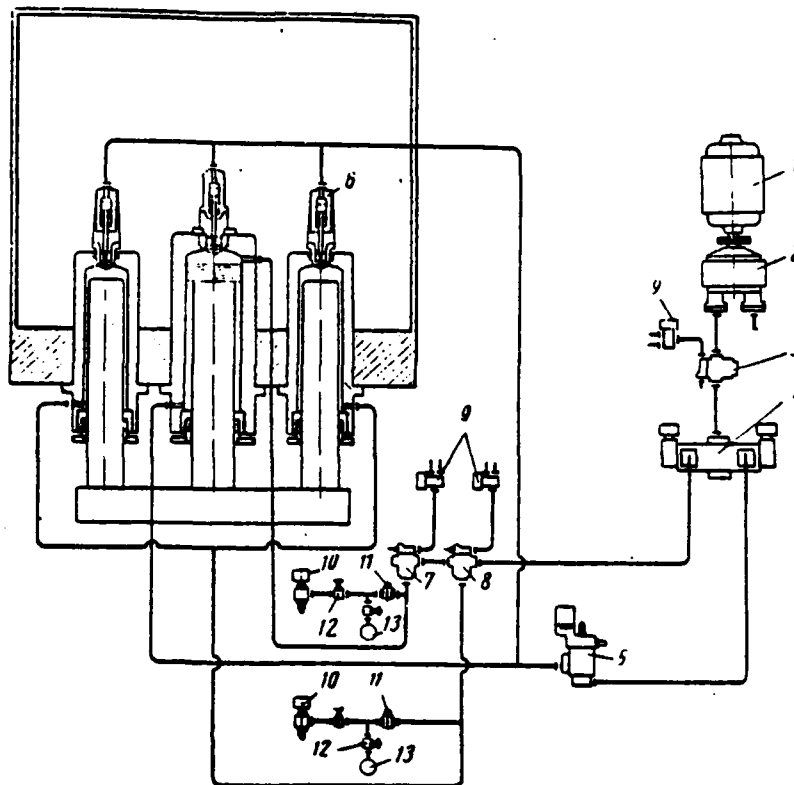

Fig. 337. The hydraulic schematic of three-cylinder press with two steps/stages of velocities and efforts/forces: 1 - electric motor; 2 - pump; 3 - safety valve; 4 - slide-valve of control; 5 - check valve of pull-backs; 6 - filler valves; 7 - valve of the start of pitch cylinder; 8 - valve of the start of extreme cylinders; 9 - auxiliary valves with the control from the electromagnet; 10 - pressure relay; 11 - check valves; 12 - shutoff valves; 13 - manometers.

Page 369.

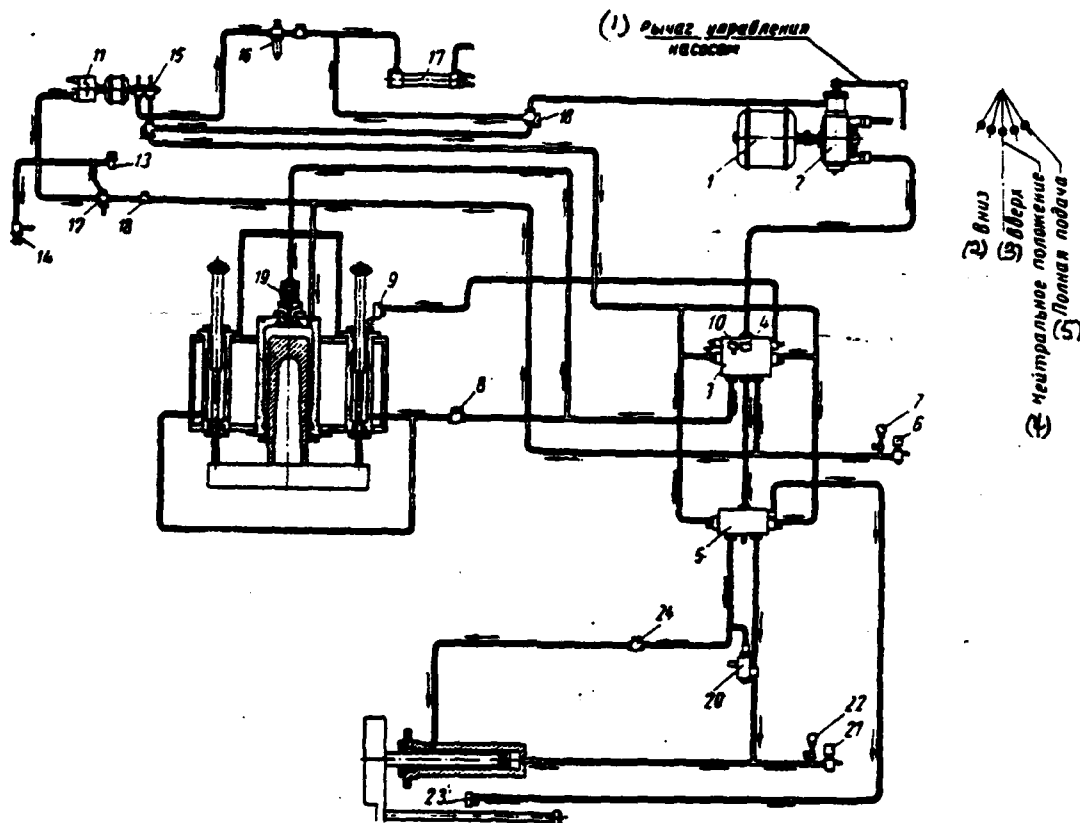

Fig. 338. The hydraulic schematic of punch press by effort/force 500 t: 1 - electric motor with the power of 110 kW; 2 - rotational-plunger pump with the supply 370 l/min; 3 - slide-valve distributor; 4 - check valve; 5 - slide-valve distributor of horizontal cylinder; 6 - pressure relay; 7 - manometer; 8 - check valves; 9 - hydraulic terminal switch; 10 - safety valve; 11 - booster pump with the supply 2 l/min and with the electric motor with

a power of 3.7 kW; 12 - safety relief valve; 13 - auxiliary valve with the electromagnet; 14 - valve of the control of ultimate pressure; 15 - pumps of auxiliary hydraulic system; 16 - filter for oil; 17 - cooler; 18 - safety valve; 19 - filler valve; 20 - drain valve; 21 - pressure relay; 22 - manometer; 23 - hydraulic terminal switch; 24 - choke/throttle.

Key: (1). Control lever of pump. (2). Down. (3). Upward. (4). Neutral position. (5). Complete supply.

Page 370.

In certain cases the feeding of pressure cylinders for the elongation/extent of entire course of their plungers, with the working and recurrent strokes, can be realized from the pump, i.e., is not required filler system and filler valve; in this case the speed of recurrent running must be several times of more than the velocity of working stroke. In order to reduce the sizes/dimensions of the valve of control, it is expedient in the conduit/manifold of the working cavity of cylinder to establish/install the drain valve, opening by pressure in the line of recurrent course.

In the stamping machines, and the work with the automatic and semiautomatic courses also in the presses of the general purpose

frequently is required.

In the electrical control system this is easily accomplished/realized by installation/setting up of the electrical contacts, which operate/wear from the hammer/cam, fastened/strengthened to the crosshead, and by an installation/setting up in the system of pressure relay with the electric contacts, with the aid of which the automatic return of cross-beam in the initial position or the start of different mechanisms can be realized.

Automatic of stroke of press can be obtained also during the manual control, with the aid of the hammer/cam, fastened/strengthened to the cross-beam and which affects the auxiliary valve of control.

In this case for the displacement of main valve in the small presses the pressure in delivery conduit of pump can be used.

the simplest schematic of this press is shown in Fig. 340.

Launching/starting and stop of press on this diagram are accomplished/realized by manual check valve 2 in the open position, which connects the forcing line of pump with the drain.

Pressure in the forcing line is constantly supported by valve 4, which is intended simultaneously and for warning/preventing the arbitrary dropping of plunger.

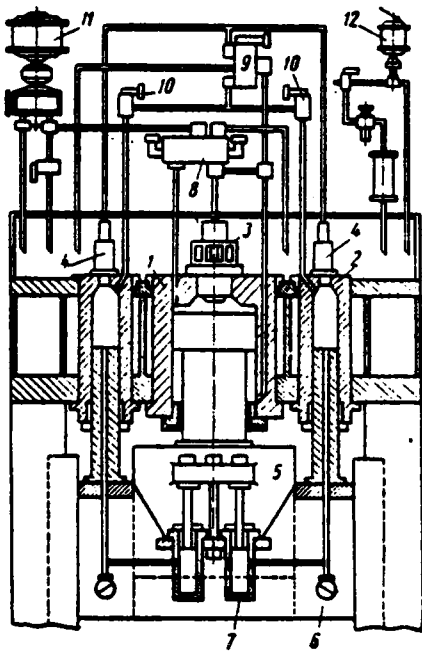

Fig. 339. The hydraulic schematic of double-action press: 1 - cylinder of internal crosshead; 2 - cylinders of external crosshead; 3 - filler valve of the cylinder of internal crosshead; 4 - filler valves of the cylinders of external cross-beam; 5 - internal crosshead; 6 - external crosshead; 7 - auxiliary cylinders, fastened/strengthened to the external cross-beam; the plungers of these cylinders are attached on the internal cross-beam; 8 - valve of control of the cylinder of internal cross-beam; 9 - valve of control of the cylinders of external cross-beam; 10 - combined - throttle and check valves; 11 - electric motor with the pump; 12 - system of filtration and oil cooling.

Page 371.

If press with the manual control must have self-catching in the upper position, then in the diagram of control the turning off/disconnecting valve, which operates/wears from the hammer/cam, fastened/strengthened to the cross-beam (Fig. 341), must be provided for.

The self-catching of cross-beam in the end position can be realized, also, without the auxiliary valve by a direct effect of hammer/cam on the main valve of control. The hydraulic schematic of press with this control is shown in Fig. 342.

For some presses, for example, blanking, correct, etc., is required the infinitely variable control and the control/check of the velocity of the motion of plunger. In this case rotational-plunger pump of variable/alternating/variable supply (Fig. 343) can be used. Pump has auxiliary cylinder for the displacement of its unit. The motion of unit is synchronized with the control handle.

AD-A139 822

HYDRAULIC PRESSES(U) FOREIGN TECHNOLOGY DIV
WRIGHT-PATTERSON AFB OH B V ROZANOV 09 MAR 84
FTD-ID(RS)T-1207-83

9/10

UNCLASSIFIED

F/G 13/9

NL

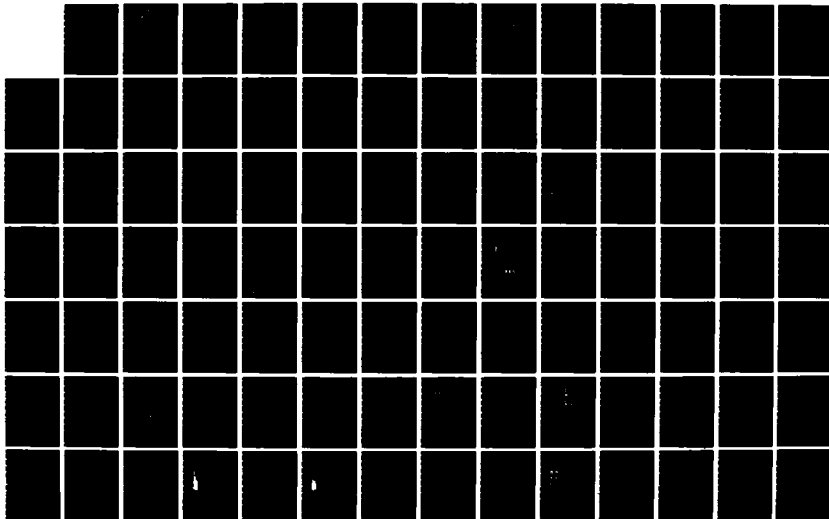

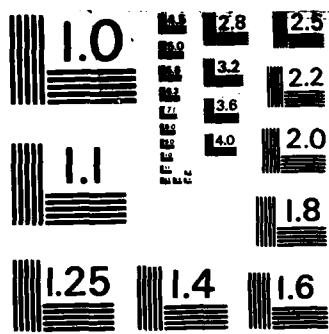

MICROCOPY RESOLUTION TEST CHART
NATIONAL BUREAU OF STANDARDS - 1963 - A

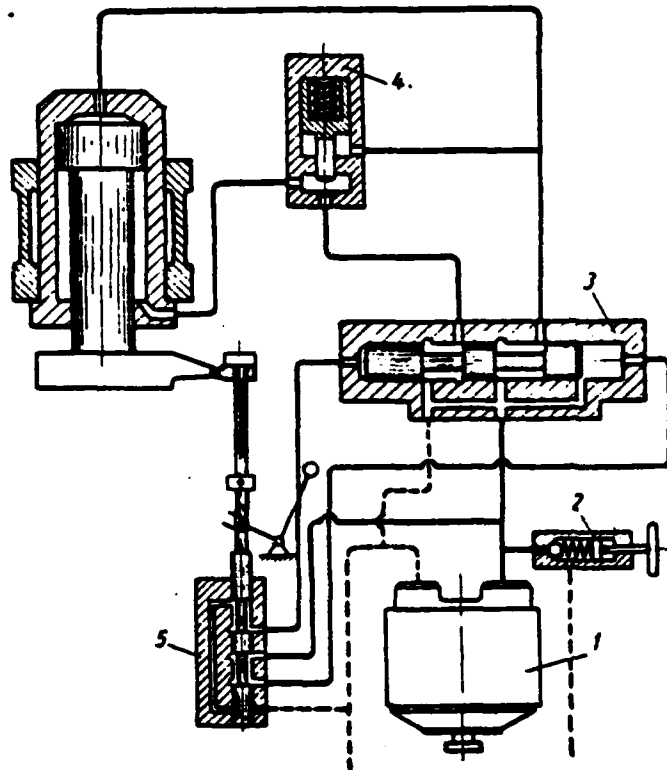

Fig. 340. The simplest schematic of the hydraulic system of press with the automatic courses: 1 - pump; 2 - valve, intended for launching/starting the press and simultaneously which fulfills the functions of safety; 3 - main valve of control; 4 - support valve; 5 - auxiliary valve.

Page 372.

Depending on the position of lever the necessary velocity of plungers is established/installed.

In this control system the effort/force on the lever is virtually constant and, thus, after pressure rise in the cylinder the operator must keep track of on the manometer. In the presses with rotational-plunger pumps of low power can be realized the sensitive control of the velocity of cross-beam by displacement of the unit of pump directly from the control handle. The schematic of press with this control is shown in Fig. 344.

Lever 1, after moving valve 2 ⁱⁿ the end position, in which the forcing line of pump is connected with the working cavity of cylinder, it comes into the contact with the stock/rod, which affects the spring 3 of pump 4. Spring in this case has small pretightening, and therefore, when the movable crosshead comes into contact with article and in the cylinder even insignificant pressure appears, the unit of the pump with auxiliary cylinder, connected with the delivery line, is established/installed in the zero position, and the motion of plunger ceases.

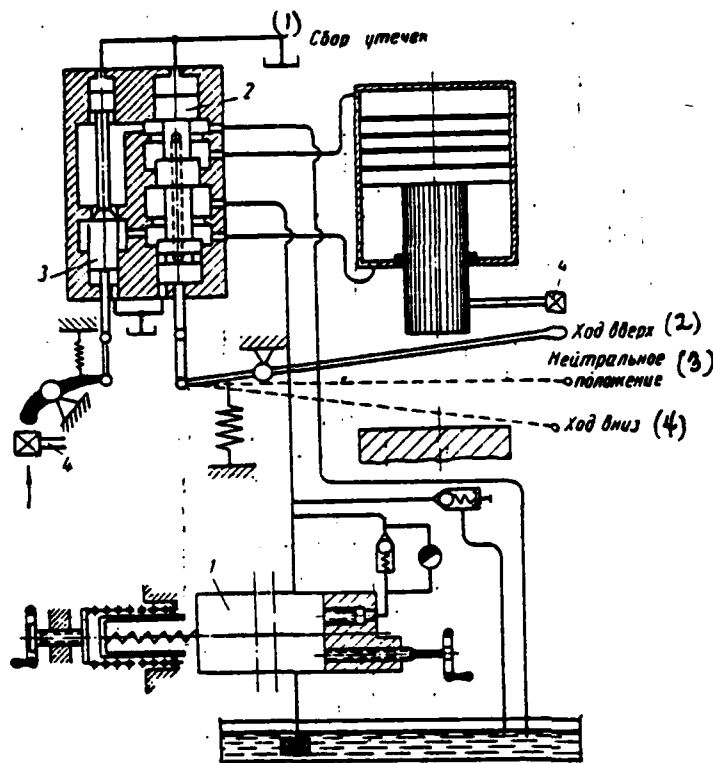

Fig. 341. The hydraulic schematic of press with the manual control, with the self-catching of the crosshead in the upper position (cross-beam in the upper position it is held by the friction of plunger against the sealing rings): 1 - pump of variable/alternating/variable supply with the automatic feed control on the pressure; 2 - valve with manual lever control; 3 - valve of the self-catching of cross-beam in the upper position; 4 - hammer/cam, fastened/strengthened to the cross-beam.

Key: (1). Collection of leaks/leakages. (2). Upstroke. (3). Neutral position. (4). Downstroke.

Page 373.

With further displacement of control handle the latter compresses the spring, under action of which the unit of pump is moved to the right. Pump begins to supply oil into the working cylinder. Pressure in it grows/rises. Under the action of this pressure the unit attempts to occupy zero position and, thus, is established a correspondence of pressure in the pressure cylinder to the position of control handle. The more the control lever displace to the right, the greater will be the pressure in the cylinder and respectively the effort/force, developed with press.

Operator, compressing the spring of pump, "feels" by hand the effort/force, developed with press.

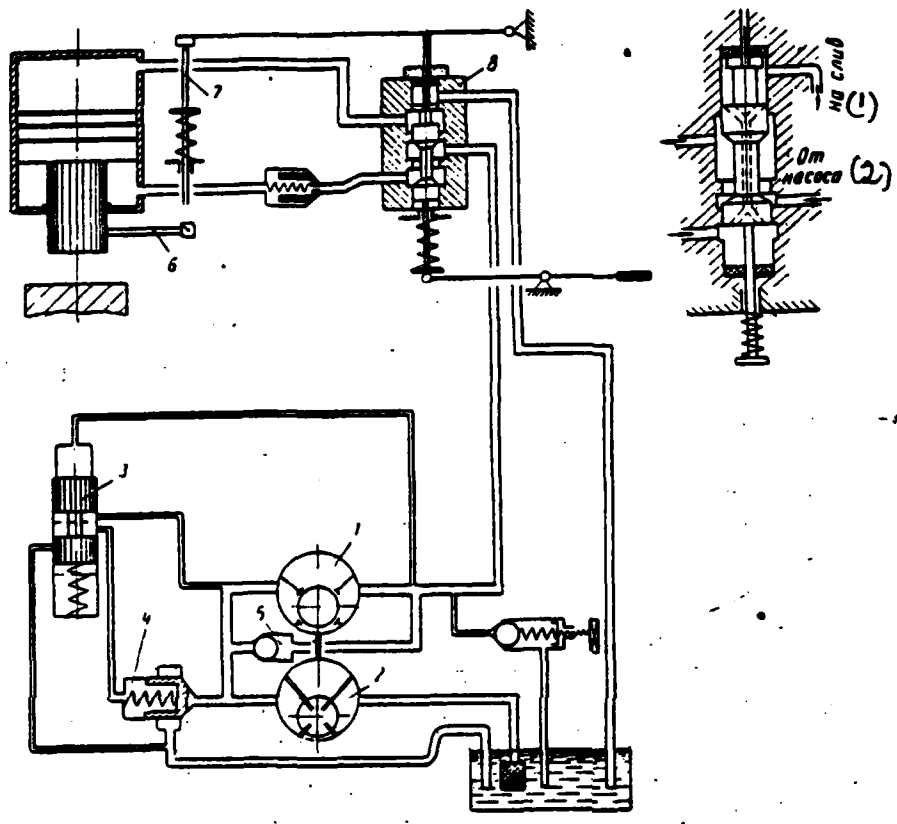

Fig. 342. The hydraulic schematic of press with two pumps of different characteristics, with the self-catching of cross-beam in the upper position: 1 - high-pressure pump; 2 - low-pressure pump; 3 - idling valve; 4 - support valve; 5 - check valve; 6 - cam; 7 - switching rod; 8 - valve of control.

Key: (1). To the drain. (2). From the pump.

Control of press with a "feeling of effort/force" on the control lever can be carried out also in such a case, when is applied the powerful/thick pump, whose supply changes with the aid of the auxiliary hydraulic cylinder. Control of press in this case can be constructed, for example, as follows.

On the line from booster pump, the feed roller, moving the unit of pump, the choke/throttle is established/installed. with the completely open choke/throttle oil from booster pump is passed into the tank. During the overlap of choke/throttle by control lever in the line appears the pressure, under action of which the spring of pump is compressed and pressure in the pressure cylinder respectively is raised. With an increase of the pressure in the auxiliary of drainage system increases the load on the choke/throttle, and through it and to the control lever.

The infinitely variable control of the velocity of cross-beam during the drive of press from the pump of constant supply, for example blade, can be obtained by the dropping of the part of the working flow to the drain. The schematic of straightening press with vane pump, in which, thus, is realized the control of the velocity of cross-beam, it is shown in Fig. 345.

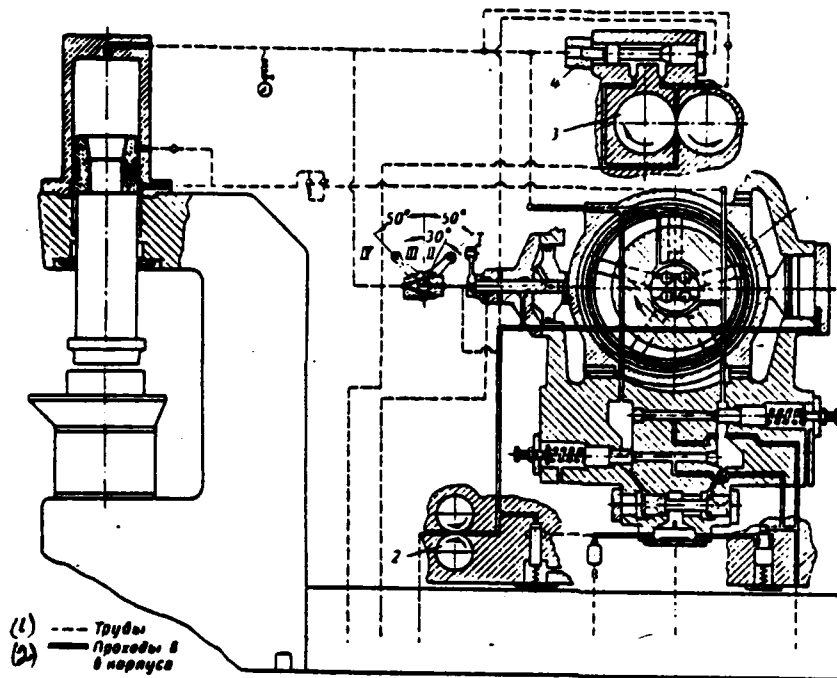

Fig. 343. The hydraulic schematic of straightening press with rotational-plunger pump of the variable/alternating/variable supply: 1 - rotational-plunger pump; 2 - auxiliary gear pump, feeder for displacing the unit of pump 1 and end cavity of the valve of control of press; 3 - gear pump for the filling of cylinder with the idling plunger; 4 - valve of control of press (translation/conversion into churning 3 with working piston stroke).

Key: (1). Ducts/tubes/pipes. (2). Passes in the housing.

At the specific pressure in the system, which corresponds to load on the cross-beam, jettisoning oil through valve 2 and respectively the velocity of transfer plunger they depend on the position of the control handle, determining the opening of choke/throttle 4, which is established/installed on the line, which connects the discharging cavity of valve 2 with the drain. With an increase in the load on the plunger, for maintaining its constant velocity, it is necessary to decrease the opening of choke/throttle, i.e., to transfer control handle into the new position (down).

With the completely closed choke/throttle the plunger is moved with the maximum speed, which corresponds to the supply of pump, if the pressure in the system, caused by load on the plunger, is less than the pressure, which corresponds to the tightening of the spring of dump valve 2.

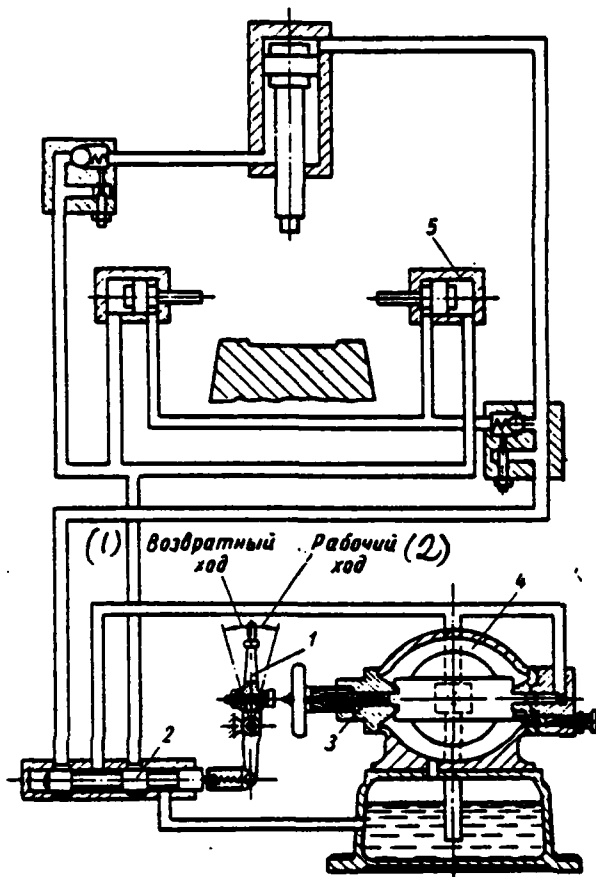

Fig. 344. The hydraulic schematic of straightening press with rotational-plunger pump: 1 - control lever; 2 - valve; 3 - spring of pump; 4 - rotational-plunger pump; 5 - cylinders for the clamp of article.

Key: (1). Recurrent course. (2). Working stroke.

Page 376.

In the given diagram and in the diagram Fig. 344, the operator "feels" by hand the increase of the effort/force, developed with press.

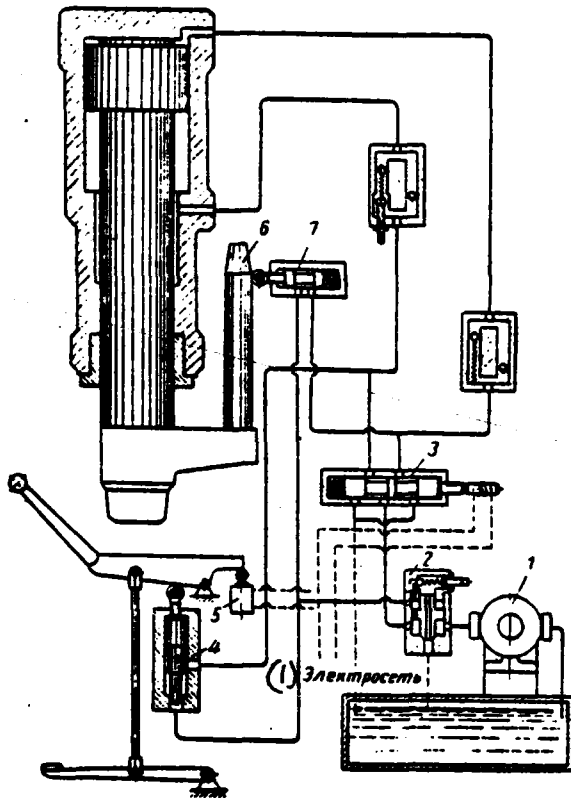

Fig. 345. The hydraulic schematic of straightening press with the rotary pump: 1 - rotary pump; 2 - dump valve; 3 - valve of control; 4 - choke/throttle; 5 - electrical switch (control of valve 3); 6 - cam for automatic stop of plunger in the upper position; 7 - valve for the connection of pump with the drain in the upper position of cross-beam.

Key: (1). Electric system.

HYDRAULIC SYSTEMS OF PRESSES WITH PUMP-AND-BATTERY DRIVE.

If we eliminate from the examination control of auxiliary mechanisms and of devices, then it is possible to establish/install the general/common/total elements of the construction of the hydraulic schematic of the press, given from the pump-and-battery station. For this purpose let us examine the simplest schematic of the vertical single-cylinder press of the general purpose, without the auxiliary mechanisms, and then let us note the special features/peculiarities of the construction of the presses of different types.

Page 377.

Fig. 346 shows the hydraulic schematic of single-cylinder press. High-pressure liquid is fed to the valve distributor of the press, with the aid of which it heads alternately for the working cylinder for the completion of working stroke and for the pull-backs for the return of the crosshead to the initial position.

Interaction of the valves of distributor is shown in Fig. 346. Filling of cylinder during the idling is accomplished/realized from the filler tank. High-pressure lines from storage battery/accumulator and from the filler tank are divided with filler valve.

The crosshead in the initial position is located in the upper position; the valves of distributor in this case, with exception of the drain valve of working cylinder, are closed. During the opening of the drain valve of return cylinders the liquid from the latter is drawn off into the filler or dump tank, and cross-beam begins to step down. Liquid from the filler tank through the filler valve enters working cylinder. With the contact of die/stamp with workpiece the pressure valve of working cylinder is opened/disclosed, connecting it with the line from the storage battery/accumulator.

With the pressure increase of liquid in the working cylinder higher than pressure in the filler tank filler valve is closed, and further motion of plunger occurs under the pressure of the liquid, which comes from the pump-and-battery station.

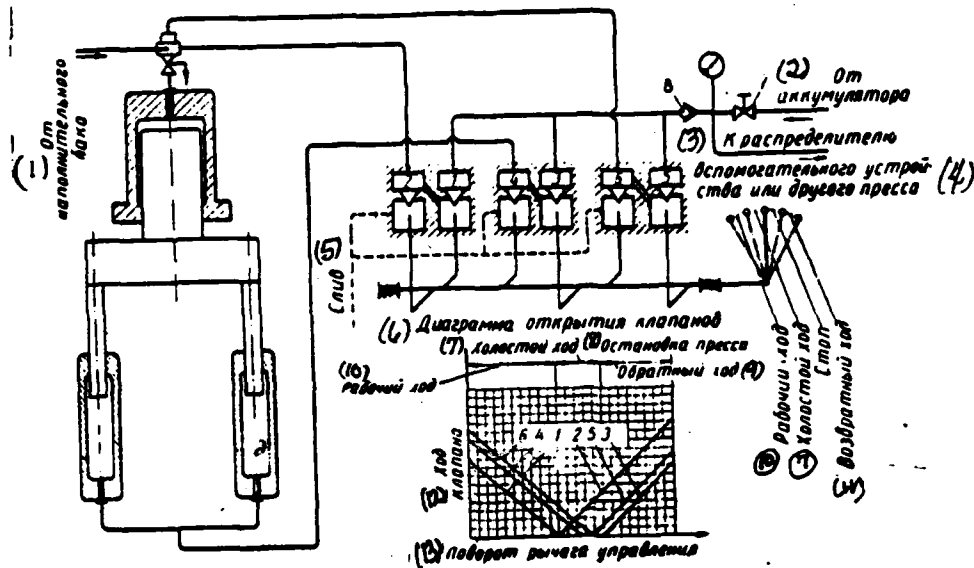

Fig. 346. The schematic hydraulic diagram ;of single-cylinder press with the pump-and-battery drive: 1 - pressure valve of working cylinder; 2- the drain valve of working cylinder; 3 - the pressure valve of pull-backs; 4 - the drain valve of pull-backs; 5 and 6 - control valves of the auxiliary cylinder of filler valve; 7 - shutoff valve; 8 - check valve.

Key: (1). From filling tank. (2). From the storage battery/accumulator. (3). To the distributor. (4) Auxiliary device or another press. (5). Drain. (6). Diagram of valve opening. (7). Idling. (8). Stop of press. (9). Back stroke. (10). Working stroke. (11). Recurrent course. (12). Valve travel. (13). Rotation of control lever.

Page 378.

At the termination of the working stroke of cross-beam the pressure valve of working cylinder and the drain valve of pull-backs are closed, and are opened the valves: drain working cylinder and forcing of pull-backs, and the cross-beam of press under the pressure of liquid from the pump-and-battery station, which affects on the plungers of pull-backs, begins to be moved upward.

Valve opening, through which high-pressure liquid enters auxiliary cylinder, precedes the opening of the pressure valve of pull-backs. Filler valve is opened/disclosed by the plunger of this cylinder, and bleeding from the working cylinder occurs through two valves: the drain valve of working cylinder and filler.

Valves for the control of the auxiliary cylinder of filler valve are applied in the powerful/thick presses with the heavy upper cross-beam and the crosshead for the smoother unloading of press.

Usually the auxiliary cylinder of filler valve does not have independent control and is connected to the line of pull-backs (Fig. 347).

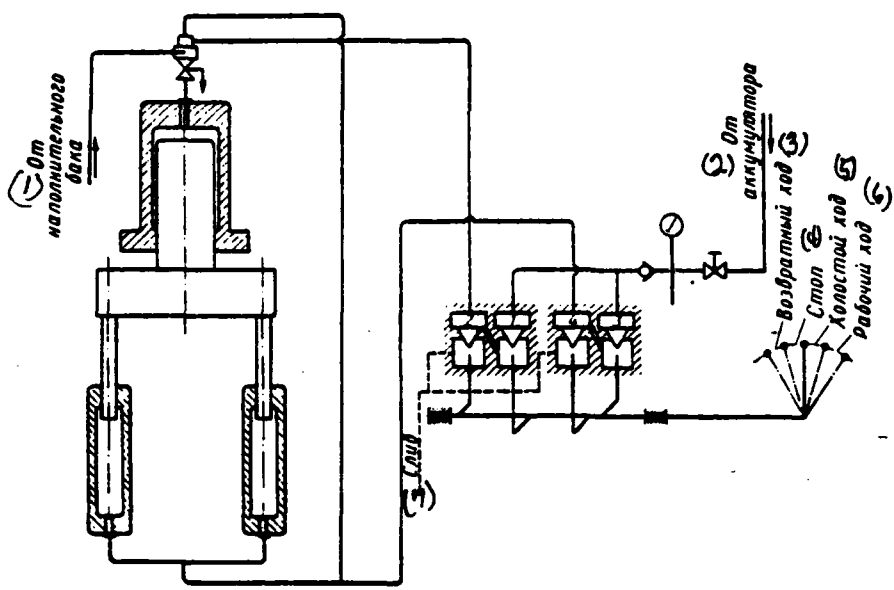

Fig. 347. The schematic hydraulic diagram of single-cylinder press with the pump-and-battery drive - attachment/connection of the auxiliary cylinder of filler valve to the line of the pull-backs: 1 - pressure valve of working cylinder; 2 - the drain valve of working cylinder; 3 - the pressure valve of pull-backs; 4 - the drain valve of pull-backs.

Key: (1). From the filler tank. (2). From the storage battery/accumulator. (3). Return stroke. (4). Stop. (5). Idling. (6). Working stroke. (7). Drain.

Are encountered the hydro-diagrams of the presses, in which the drain valve of working cylinders is absent. Unloading from the pressure of working cylinders in this case is accomplished/realized by the pilot valve (discharging), installed into the filler valve (Fig. 348). This performance of diagram cannot be recommended for the high-speed presses for following reasons. The arrangement/position of relief valve of the required sizes/dimensions in the filling valve is difficult and complicates its construction/design. With the bleeding of liquid under high pressure through relief valve of low diameter its rapid wear proceeds from the erosion and the cavitation. The repair of relief valve is hindered/hampered, since the filler valve usually is installed on upper crosshead of press (on the working cylinder).

In the hydraulic presses with the storage battery/accumulator of presses the liquid of constant pressure expends/consumes, and expenditure of energy, consumed by press for one course, does not depend on resistance on the die/stamp, but it depends on the value of working stroke.

For the purpose of the savings of working high-pressure fluid with the working stroke the presses frequently are constructed with several steps/stages of efforts/forces on the cross-beam. Several steps/stages of the efforts/forces easily to obtain, if to perform

press with several working cylinders.

Depending on the required effort/force working high-pressure fluid is supplied into the appropriate quantity of cylinders. The presses, which develop the large efforts/forces, are constructed multicylinder mainly, in upper cross-beam of which it is easy to place several cylinders.

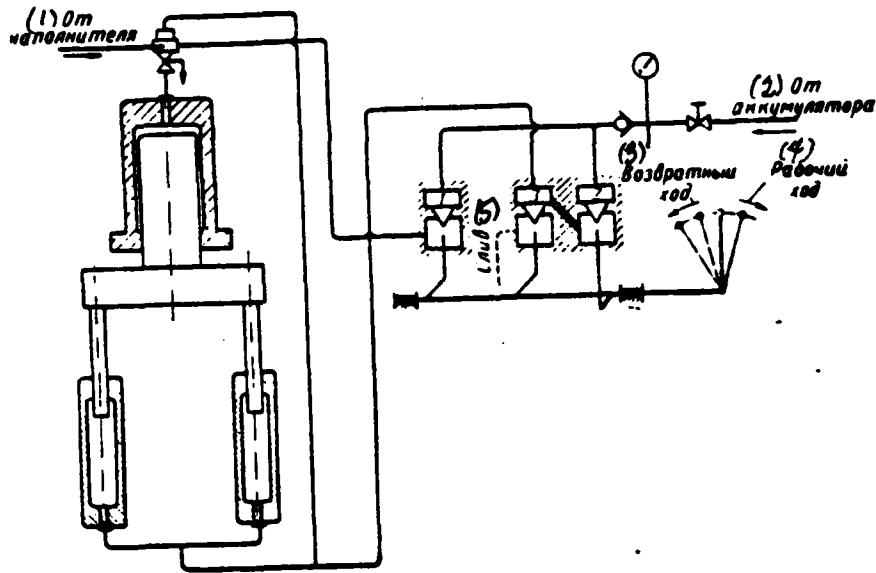

Fig. 348. The schematic hydraulic diagram of single-cylinder press with the pump-and-battery drive - bleeding from the working cylinder only through the filler valve: 1 - pressure valve of working cylinders; 2 - the pressure valve of pull-backs; 3 - the drain valve of pull-backs.

Key: (1). From the filler. (2). From the storage battery/accumulator. (3). Return stroke. (4). Working stroke. (5). Drain.

Page 380.

For the start of different number of cylinders is applied either additional valve distributor (Fig. 349), or mechanism for valve opening of basic valve distributor has a device, which ensures the specific sequence of the discovery/opening the corresponding valves for the start of different number of cylinders.

For the purpose of obtaining several steps/stages of the efforts/forces of press the multiplier, established/installed on the line between the press and the pump-and-battery stations also is applied and that raising the pressure of battery liquid several times usually 2 times).

Multiplier is included only if it is necessary to obtain complete effort/force. In the remaining time of presses it feeds by liquid directly from the battery station.

The schematic diagram of control of press with the multiplier on the working line is shown in Fig. 350.

In the powerful/thick presses the multiplier frequently is made with three high-pressures cylinder, which makes it possible to have three steps/stages of efforts/forces.

For the savings of working high-pressure fluid with the return stroke in the vertical presses the balancing cylinders, constantly connected with the battery station, apply, together with the driving/homing pull-backs.

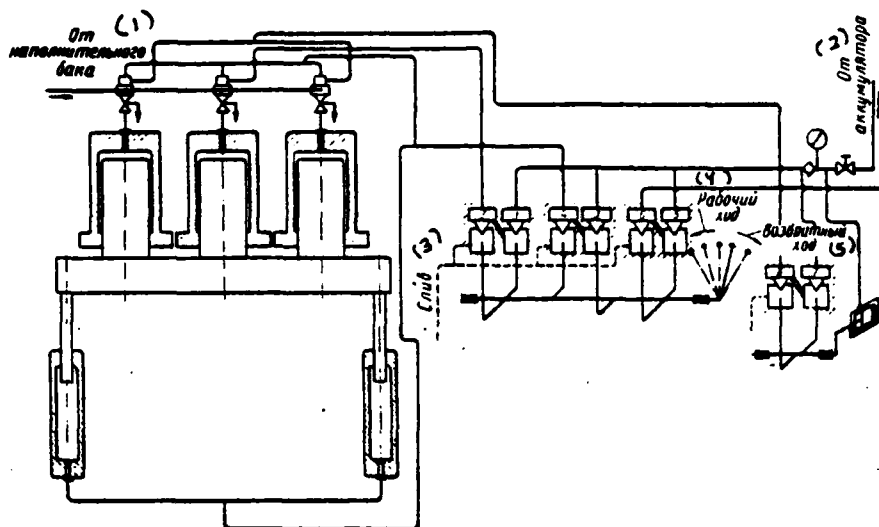

Fig. 349. The schematic hydraulic diagram of three-cylinder press with the additional valve distributor for the start of press to different steps/stages of the efforts/forces: 1 and 2 - filler and drain valves of pitch cylinder; 3 and 4 - forcing and drain valves of pull-backs; 5 and 6 - forcing and drain valves of servocylinder; 7 and 8 - forcing and drain valves of outer working cylinders.

Key: (1). From the filler tank. (2). From the storage battery/accumulator. (3). Drain. (4). Working stroke. (5). Return stroke.

Page 381.

The effort/force of the balancing cylinders is selected

depending on rapidity of press. With the considerable difference in the value of working and return strokes with the aid of the balancing cylinders the considerable savings of working high-pressure fluid can be obtained with the work of press.

Of the hydraulic presses with pump-and-battery drive the forging presses, which until a comparatively recent time were made with the drive from the steam-air multiplier, are highest-speed.

Of the forging presses large rapidity with the work is required by short, but frequent strokes during the exhaust operations and finishing of forgings (planishing), that the long time was obstruction to the use/application of more economical, in the comparison with the steam drive, pump-and-battery drive.

For guaranteeing high rapidity of press with its work at first (smallest) stage of effort/force the pull-backs must be found under the constant pressure from the pump-and-battery station, but the filler valves of the working cylinders (or one cylinder), which do not develop effort/force, must be opened for the free filling and the emptying of cylinders. Constant connection of pull-backs with the pump-and-battery station provides the rapid reversal of the crosshead, is shortened boost period.

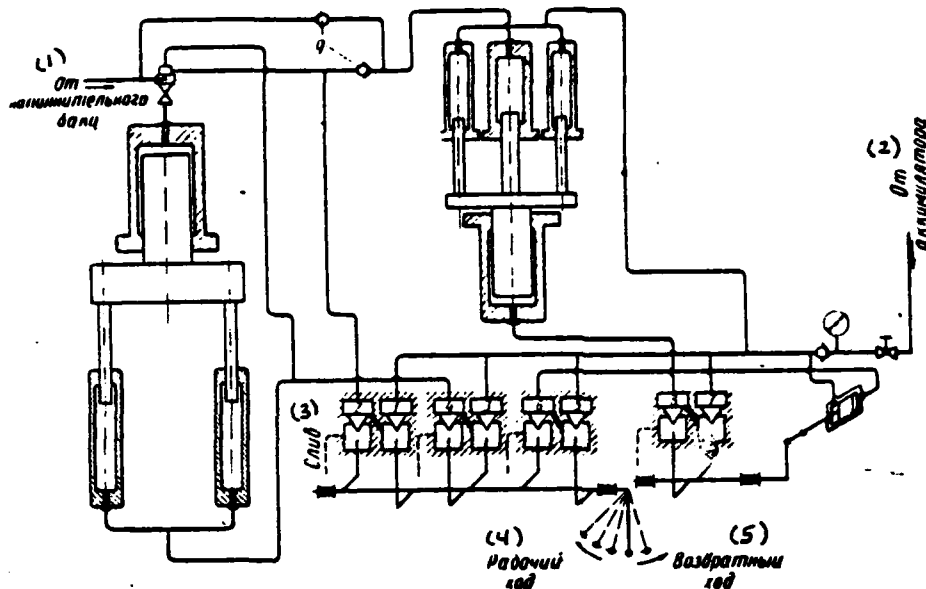

Fig. 350. The schematic hydraulic diagram of press with the multiplier: 1 and 2 - forcing and drain valves of working cylinder; 3 and 4 - forcing and drain valves of pull-backs; 5 and 6 - forcing and drain valves of servocylinder; 7 and 8 - forcing and drain valves of multiplier; 9 - check valves.

Key: (1). From the filler tank. (2). From the storage battery/accumulator. (3). Overflow. (4). Working stroke. (5). Return stroke.

Page 382.

Arrestment of the forcing and drain valves of pull-backs and part of

the filler valves simplifies control of press and is shortened the cycle time of its work.

The hydraulic schematic of contemporary forging press is shown in Fig. 351 (see insert). Auxiliary mechanisms (extensible table, knockout) and mechanisms for their control in the diagram are not shown. The diagram of valve opening of control of working and pull-backs is shown in Fig. 352.

For warning/preventing the excessive dropping of cross-beam valve 1 (Fig. 351), controlled by distributor with valves 15 and 16, is provided. With the normal operation the cavity above valve 1 is connected through open valve 15 with the forcing line from the storage battery/accumulator. When valve 15 is closed by the hammer/cam, fastened/strengthened to the cross-beam in its end lower position, and valve 16 is opened/disclosed, the cavity above valve 1 is connected with the drain and it surfaces, connecting working cylinder with overflow of forcing line from the storage battery/accumulator, and therefore it is not possible to recognize this solution as successful.

For the purpose of warning/prevention of the excessive dropping of cross-beam at a pressure in the working cylinders it is better to establish/install the locking controlled valve in the intake forcing

line of valve distributor.

With the pump-and-battery drive powerful/thick stamping multicylinder machines are manufactured.

The use of valve distributors with the remote control is the special feature/peculiarity of the hydraulic schematics of such presses, since for the passage of large fluid flows into the pressure cylinders and its drain of them it is necessary to apply valves large-diameter.

Examples of the hydraulic schematics of stamping machines are shown in Fig. 353 (see insert) and 354.

In the powerful/thick presses with a large quantity of working cylinders it is expedient to construct hydraulic diagram so that the press would work with a maximally possible number of steps/stages of effort/force.

For the more uniform load of working cylinders, obtaining of a larger number of steps/stages of effort/force, and also reduction/descent in the value of a maximum pressure differential between the storage battery/accumulator and the working cylinders for the powerful/thick press, which consumes a large quantity of working

fluid, it is expedient to apply the pump-and-battery station of two sections with different pressures. In this case since, as it was shown in the first chapter, energy losses to the compression of liquid were proportional to operating pressure in the cylinders, considerable savings can be obtained also during the operation of press at the intermediate steps/stages on the effort/force with the feeding of presses by the liquid of reduced pressure.

In the powerful/thick presses the moving elements of the press have considerable weight, and therefore during the construction of diagram must be provided for the smooth stop of cross-beam in its upper position with the return flow, and also smooth transition/transfer from the idling speed to the velocity of working stroke.

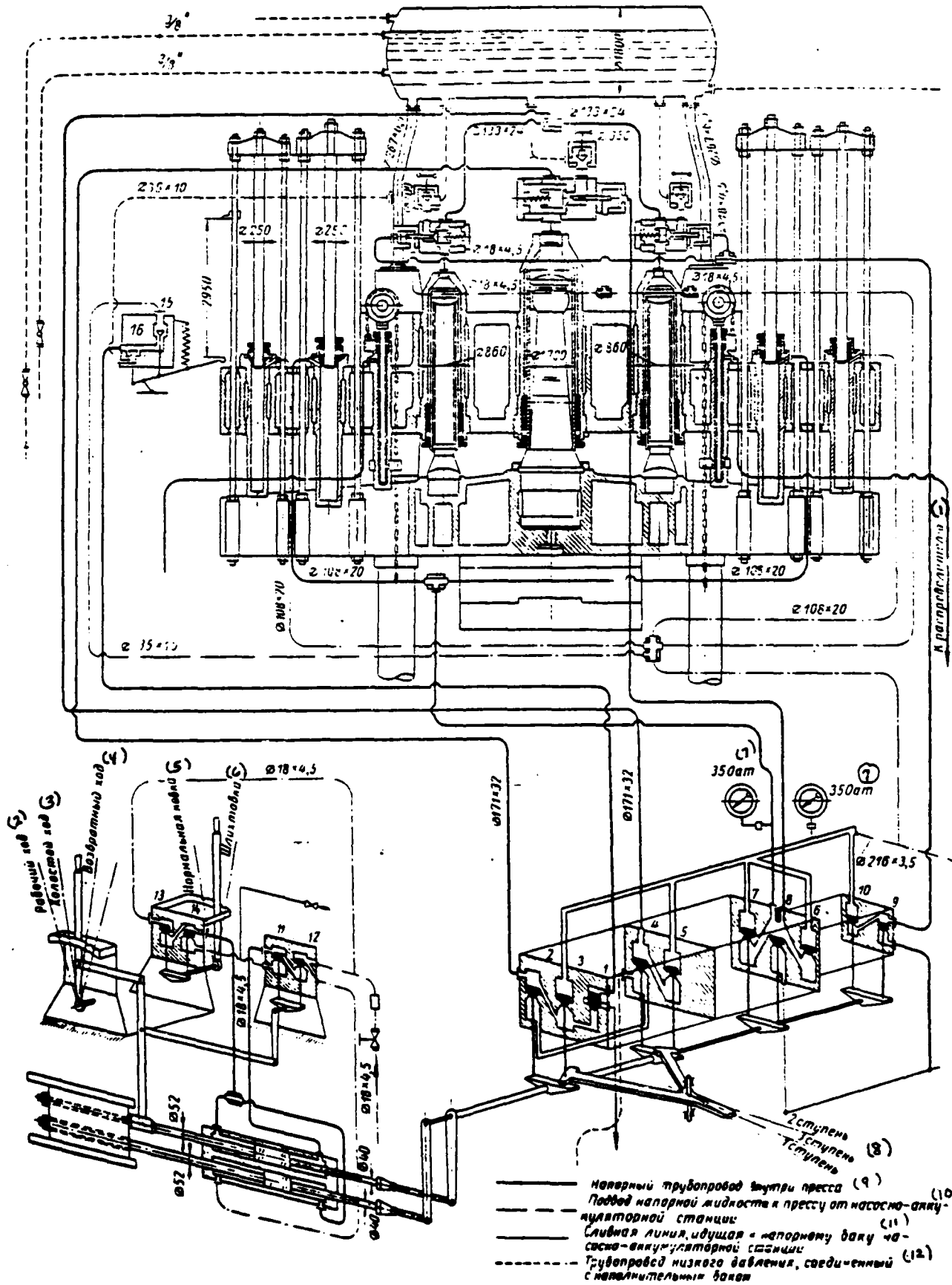

Fig. 351. The hydraulic diagram of control of the forging press: 1 - float valve of the emergency disconnection of working cylinders during the excessive dropping of the crosshead; 2 and 3 - drain and pressure valves of pitch working cylinder; 4 and 5 - drain and pressure valves of extreme working cylinders; 6 - safety valves of pull-backs; 7 and 8 - forcing and drain valves of pull-backs; 9 and 10 - drain and pressure valves of the auxiliary cylinders of filler valves; 11 and 12 - drain and forcing control valves of hydraulic device for the rotation by camshaft; 13 and 14 - forcing and drain control valves of the mechanism of rotation for valve opening of pull-backs and auxiliary cylinders of filler valves with the work of press by finishing courses; 15 and 16 - auxiliary control valves of float valve 1.

Key: (1). To distributor. (2). Working stroke. (3). Idling. (4). Normal forging. (6). Smoothing. (7). atm(tech). (8). step/stage. (9). Delivery conduit inside the press. (10). Supply of pressure fluid to the press from the pump-and-battery station. (11). Drain line, which goes to forcing tank of the pump-and-battery station. (12). Low-pressure conduit/manifold, connected from the filler ones by tank.

In the case of the powerful/thick recurrent and balancing pressure cylinders the use/application of a separate pump-and-battery station for their feeding can prove to be justified. In this case a drop/jump in the storage pressure of the storage battery/accumulator, which feeds pull-backs, can be accepted considerably greater in the comparison with the pressure differential in cylinders, from which working cylinders feed.

With a larger pressure differential the effort/force, developed with pull-backs, will more intensely descend during the motion of cross-beam upward and raised more intensely during the motion of it down. Thus, there can be obtained the necessary deceleration of the motion of cross-beam toward the end of the return and idling strokes. In the separate stations for the feeding of working and pull-backs the possibility, in the case of necessity, changes in the operating pressure of the pump-and-battery station appear. For example, if on the load of press it long time must work with the lowered/reduced force, pressure in the pump-and-battery station can be lowered, which will ensure the more economical operation of press. The speed of recurrent running of the crosshead can be regulated by a change of the pressure in the pump-and-battery station.

The majority of hydraulic presses manufactures with different auxiliary devices - extensible tables, knockouts; punch presses - with the pressing cross-beams; tube and bar presses - with the mechanisms for the displacement of container, supply of ingot into the container and so forth, etc. During the pump-and-battery drive manual control of valve distributors is applied mainly, but powerful/thick presses do not work with the strictly steady cycle on the time, and does not have the capability to utilize pressure in different drainage systems as the impulses/momenta/pulses for the series connection of mechanisms, as this is done in many presses with the pumping batteryless drive.

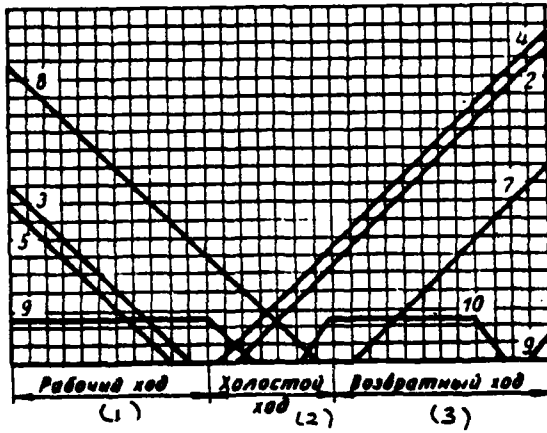

Fig. 352. Diagram of valve opening of forging press.

Key: (1). Working stroke. (2). Idling. (3). Return stroke.

Page 384.

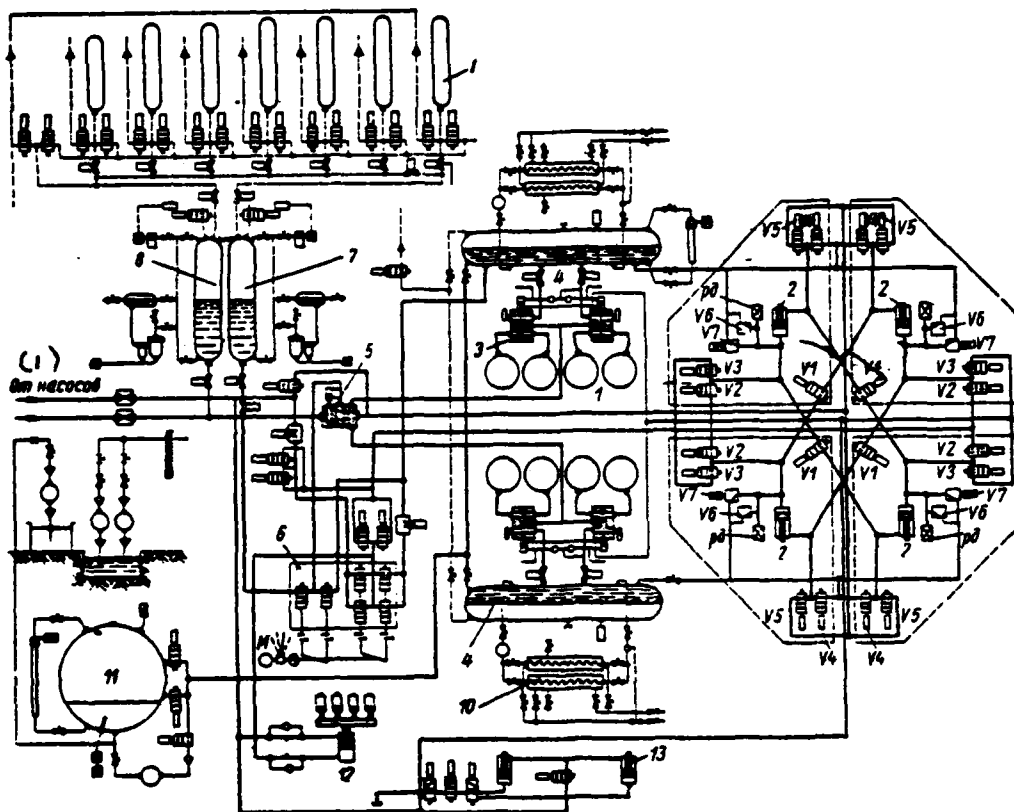

Fig. 354. The hydraulic schematic of stamping machine by effort/force 31500 t: 1 - master cylinders; 2 - recurrent and compensating cylinders; 3 - filler valves; 4 - filler tank; 5 - main bleeder; 6 - control valves; 7 - water bottles of pull-backs; 8 - water bottles of master cylinders; 9 - compressed air tanks; 10 - water cooler; 11 - receiver tank; 12 - servocontrol by filler valves; 13 - knockouts; V1 - valves for double-t joint of pull-backs; V2 - pressure valves of pull-backs; V3 - support valves; V4 - drain valves (from the upper

DOC = 83120718

PAGE

797

cavities of pull-backs); V5 - feed valves; V6 - safety valves; V7 -
pressurization valves; rd - pressure relay.

Key: (1). From the pumps.

Page 384a.

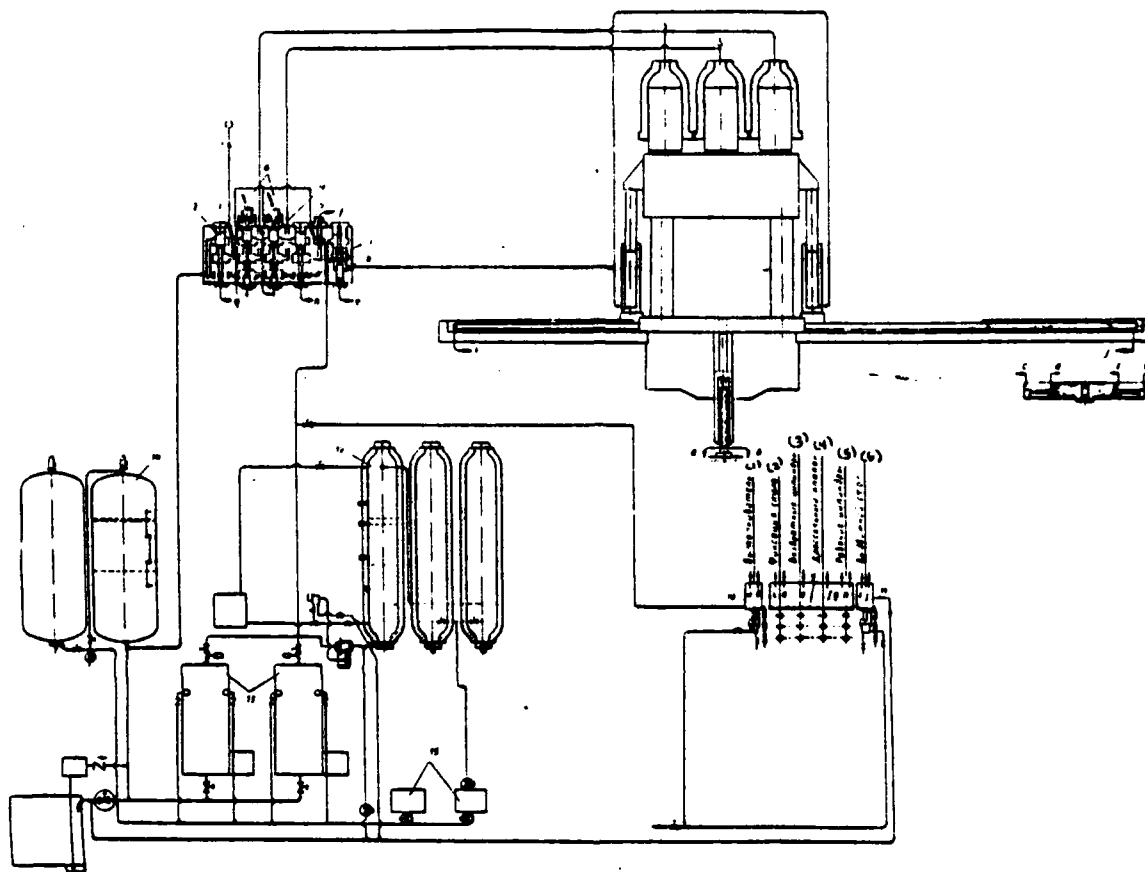

Fig. 353. The hydraulic schematic of stamping machine by effort/force 10000 t: 1 - press; 2 - drain valve; 3 - the pressure valve of outer cylinders; 4 - the pressure valve of pitch cylinder; 5 - pressure valve (exhaust); 6 - the pressure valve of reverse/inverse cylinders; 7 - the drain valve of reverse/inverse cylinders; 8 - valves of switching the steps/stages of effort/force; 9 - valve of control of press; 10 - valve distributor of control of knockout; 11 - valve

distributor of control of table; 12 - storage battery/accumulator; 13 - high-pressure pumps; 14 - filler tanks; 15 - compressors.

Key: (1). Knockout. (2). Fixation of table. (3). Pull-backs. (4). Throttle valve. (5). Working cylinders. (6). Extensible table.

Page 384b.

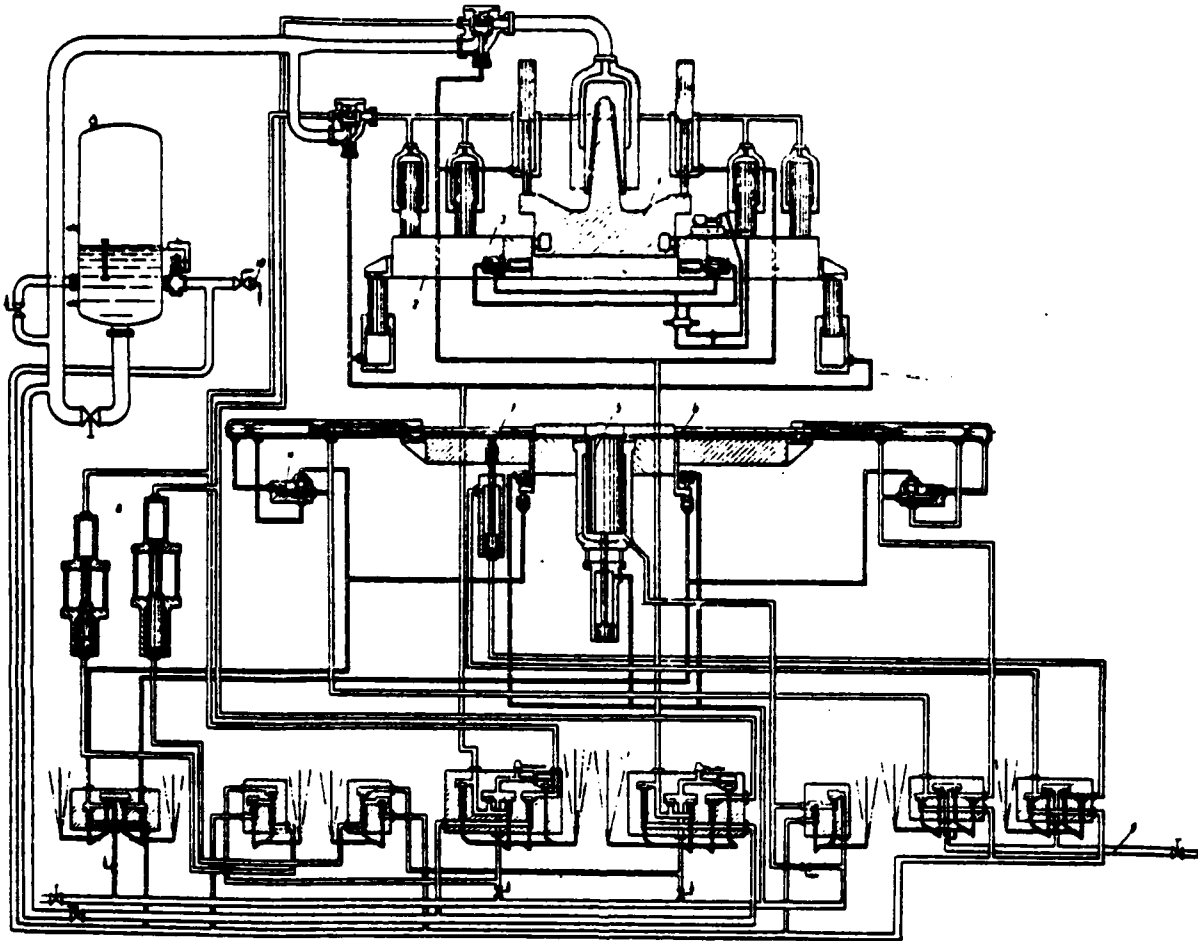

Fig. 355. The hydraulic schematic of blanking double-action press by effort/force 3000 t: 1 - exhaust slider; 2 - pressing slider; 3 - device for pairing of the motion of exhaust and clamping sliders; 4 - valve device for braking of table; 5 - clamping fixture of table; 6 - central knockout; 7 - side knockout; 8 - multipliers; 9 - forcing line; 10 - drain line.

Page 385.

Therefore in the presses with pump-and-battery control linkage of auxiliary mechanisms, as a rule, is accomplished/realized by the independently effective valve distributors. The hydraulic schematic of punch press is shown by the effort/force 3000 t of double action with a large number of different, separately controlled mechanisms in Fig. 355 (see insert).

In the powerful/thick presses with the extensible tables, which have large course, for shortening of cycle time the work of the press of the speed of the motion of table are received as those increased. For the avoidance of impacts/shocks with the stop of table the brake valves, which operate/wear from cams, fastened on the table, are applied. The hydro-diagram of the drive of extensible table with such valves is shown in Fig. 356.

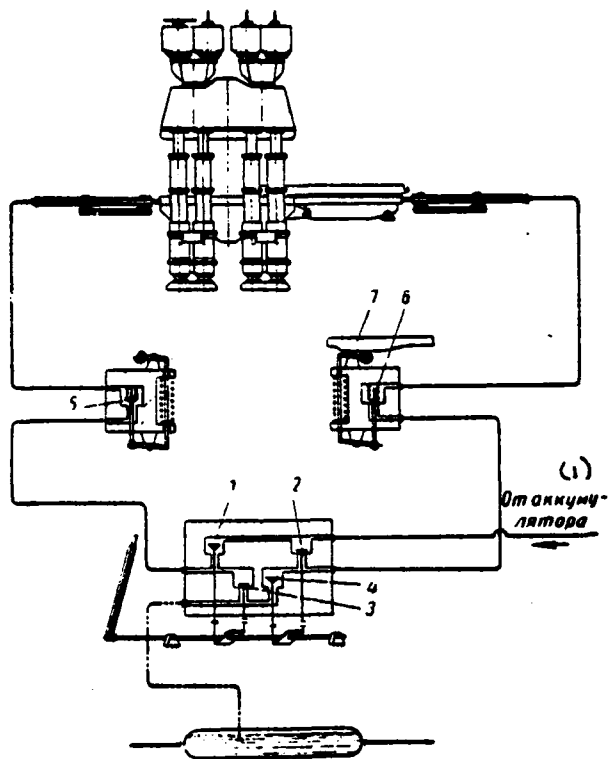

Fig. 356. The hydraulic schematic of the extensible table of stamping machine by effort/force 30000 t: 1 and 2 - pressure valves; 3 and 4 - drain valves; 5 and 6 - throttle (brake) valves; 7 - cams, fastened on roller table.

Key: (1). From the storage battery/accumulator.

Page 386.

The motion of the crosshead with the idling in vertical

hydraulic press is accomplished/realized under its own weight of cross-beam and partially under the pressure of liquid from the filler tank.

In the horizontal presses for the realization of the motion of cross-beam with the idling are established/installed the auxiliary cylinders of low power and in the rare cases (in the slow presses) the motion of cross-beam they are accomplished/realized by a liquid from the filler tank; in this case the pressure in the latter is selected somewhat increased (to 10 kg/cm²).

DISTRIBUTORS AND OTHER CONTROL EQUIPMENT.

Slide-valve distributors.

Slide-valve distributors (valves) are applied mainly in the presses with the batteryless pumping drive. Valves, depending on designation/purpose, are made two- or three-position ones with different number of passes for oil.

Fig. 357 shows the schematic diagrams of the valves, most frequently used in the hydropresses.

For the systems, which work on mineral oil, the

sealing/packing/compaction against the leaks/leakages of oil through the valve is accomplished/realized by an exact fit of valve in the housing with the aid of the grinding, which provides the clearance between the valve and the bushing not more than 0.02 mm to the diameter. For decreasing the friction the valves manufacture from steels, which allow/assume their quenching to the hardness of 50-55 units Rockwell. Into the housing of valve, with the relatively larger sizes/dimensions of the latter, the steel bushings are pressed, which are also subjected to quenching.

Fig. 358 shows the schematic of the valve, which slides in the bushing, pressed in the housing.

For the avoidance of the clamp of valve by one side to the housing, an oil supply to the valve must be accomplished/realized on the circular boring, and on the valve turned the ring grooves with the width of 0.5-0.75 mm and with the depth of 0.3-0.4 mm.

The leaks/leakages through the valve can be determined according to formula [21]

$$w = \frac{\pi p Z^3 d}{96 \mu \delta}, \quad (320)$$

where p - pressure of liquid in kg/cm^2 ;

μ - the absolute viscosity of liquid in $\text{kg}\cdot\text{s}/\text{cm}^2$;

δ - gap length along the axis of valve (overlap of valve) in cm;

d - nominal diameter of valve in cm;

Z - clearance between the valve and the bushing in cm ($d_1 - d_2$).

Absolute viscosity μ is determined according to the equation

$$\mu = \nu \frac{\gamma}{g},$$

where γ - specific gravity/weight in kg/cm³ (for oil $\gamma = 0,0009$ kg/cm³);

g - acceleration of gravity in cm/s²;

ν - kinematic viscosity in cm²/s.

Page 387.

Kinematic viscosity depending on the viscosity, expressed in the Engler degrees (E°), is determined from the formula

$$\nu = 0,0732E^\circ - \frac{0,0631}{E^\circ}.$$

Effort/force for the displacement of valve in the housing can be tentatively determined according to the formula

$$P = \kappa \cdot d \cdot l \cdot p \cdot f, \quad (321)$$

where d - nominal diameter of valve in cm;

l - maximum length of valve (in cm), at which the most one-sided possible high pressure of liquid to the valve;

p - maximum pressure in the hydraulic system in kg/cm^2 ;

f - coefficient of the friction of valve against the housing; $f=0.05$;

κ - coefficient, depending on the precision of manufacturing valve
 $\kappa=0.15-0.3$.

With the use of this formula it is necessary to keep in mind that the less d and l , the greater the value κ .

In the systems, which work on the water emulsions, the sealing/packing/compaction against the leaks/leakages of the emulsion through the valve is achieved by the use/application of sleeves (Fig. 359) or piston rings (Fig. 360).

Valves small over diameter for the presses, which do not require automatic control, are moved by lever manually (Fig. 361). For the

presses with the automatic or semiautomatic control the valves are made with the electromagnets, installed on the ends/faces of the housing of valve (Fig. 362).

For the displacement of large-size valves are applied either auxiliary hydraulic systems or is utilized the compressed air of shop network/grid. Fig. 363 shows the construction/design of the valve, moved by oil from the auxiliary hydraulic system.

The end cavities of valve are controlled by the two-position valves of low sizes/dimensions, by moving electric magnets.

In the auxiliary hydraulic system blade or gear low-pressure pumps are utilized. The forcing line of support system constantly is under pressure, supported by the safety valve, through which the complete supply of pump passes. The pump of support system frequently simultaneously is utilized for the forcing of oil into the filter and the cooler. The schematic of this support system is shown in Fig. 336.

The unproductive expenditure of energy is a shortcoming in this system, since the pump constantly supplies oil under the total pressure through the safety valve. In order to avoid this, into the line from the pump small spring storage battery/accumulator for the

discovery/opening of the idling valve of pumps (Fig. 364) can be connected.

For the displacement of large-size valves the piston storage batteries/accumulators, pressure in which is supported by the compressed air (Fig. 365), are applied also.

Pages 388-389.

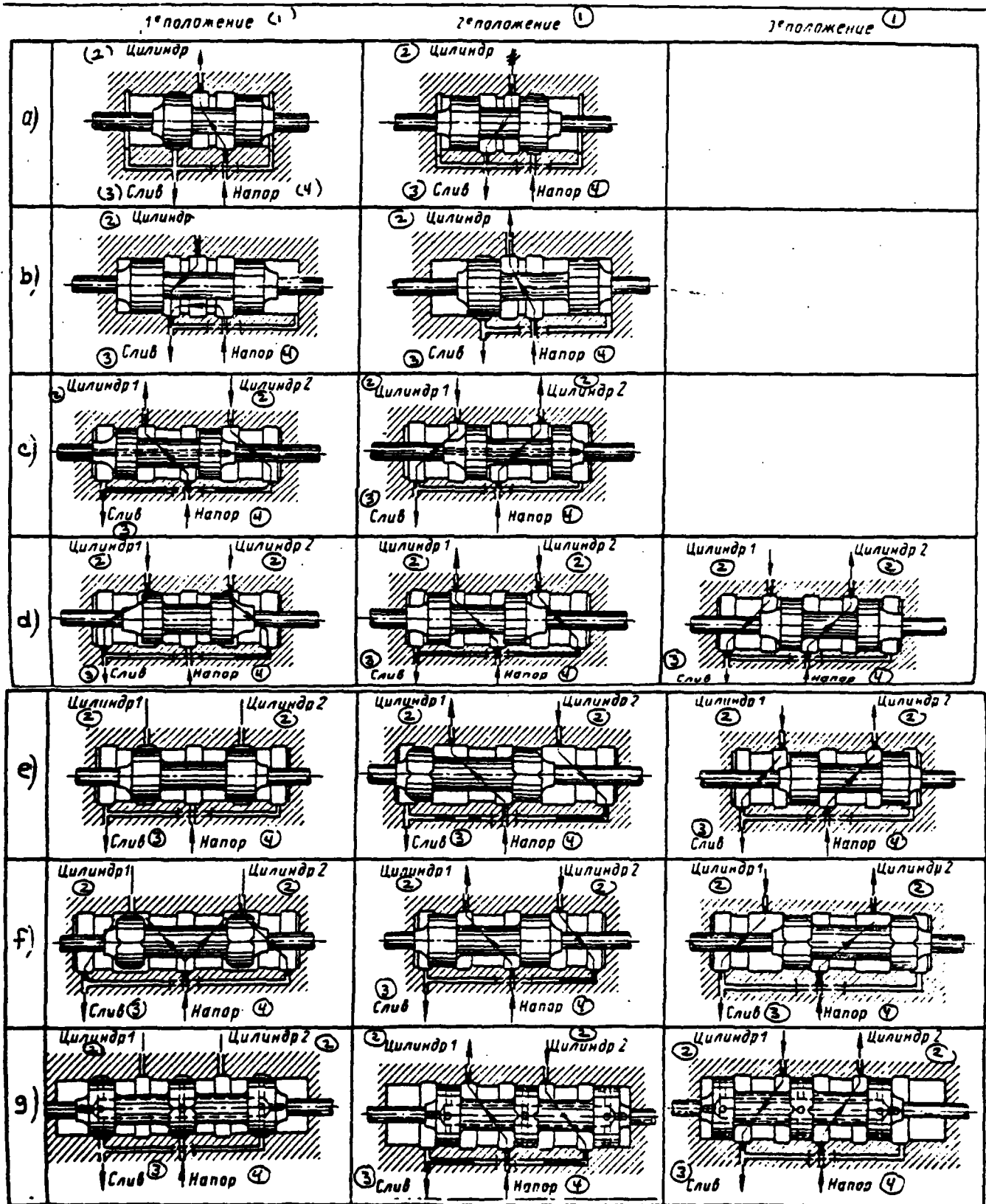

Fig. 357. Schematic diagrams of the valves, used in the hydropresses:
a) two-position, short-stroke with three passes, without the passage of pressure to the drain and without the fixation of operating mechanism; b) the same, but with the passage of pressure to the drain; c) two-position with four passes; d) three-position with four passes, without the passage of pressure to the drain, without fixation of working mechanism; e) three-position with four passes, without the passage of pressure to the drain, with the fixation of mechanism; f) the same, with the passage of pressure to the drain without the fixation of operating mechanism; g) the same, but with the fixation of operating mechanism.

Key: (1). position. (2). Cylinder. (3). Drain. (4). Pressure.

Page 390.

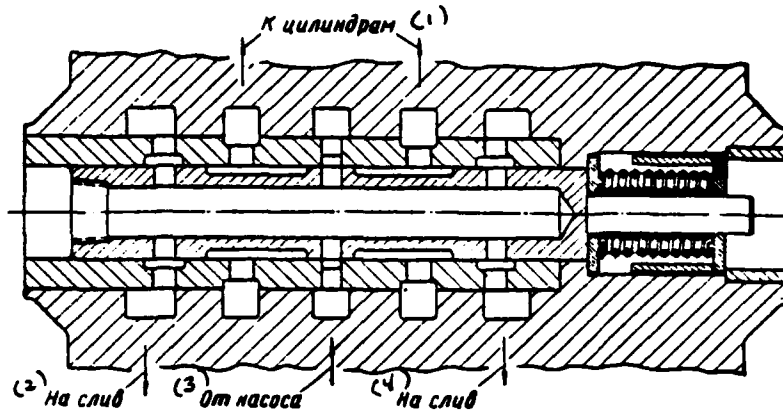

Fig. 358. The schematic of valve with pressfitted into the housing bushing.

Key: (1). To the cylinders. (2). To the drain. (3). From the pump. (4). To the drain.

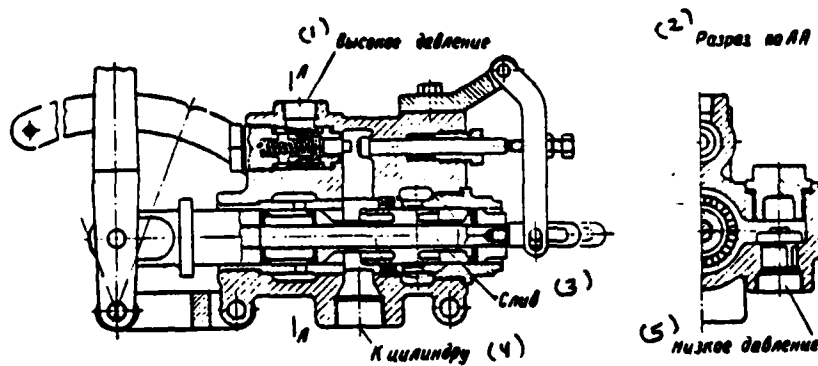

Fig. 359. Valve, packed by sleeves, for the hydraulic system, which works with two pressures. Maximum pressure 100 kg/cm².

Key: (1). High pressure. (2). Section AA. (3). Drain. (4). To the cylinder. (5). Low pressure.

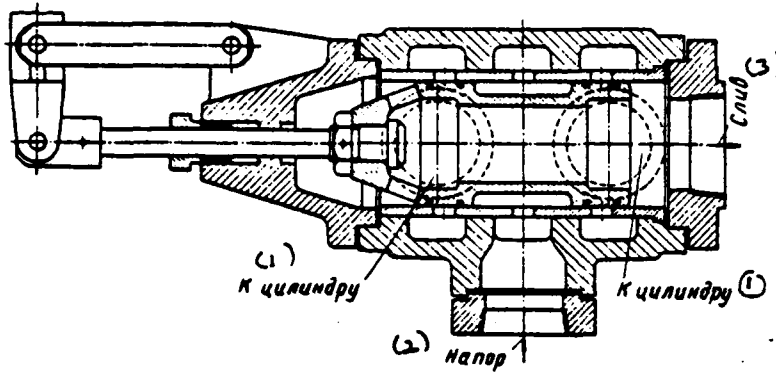

Fig. 360. Valve, packed by piston rings. Maximum pressure 20 kg/cm².

Key: (1). To the cylinder. (2). pressure. (3). drain.

Page 391.

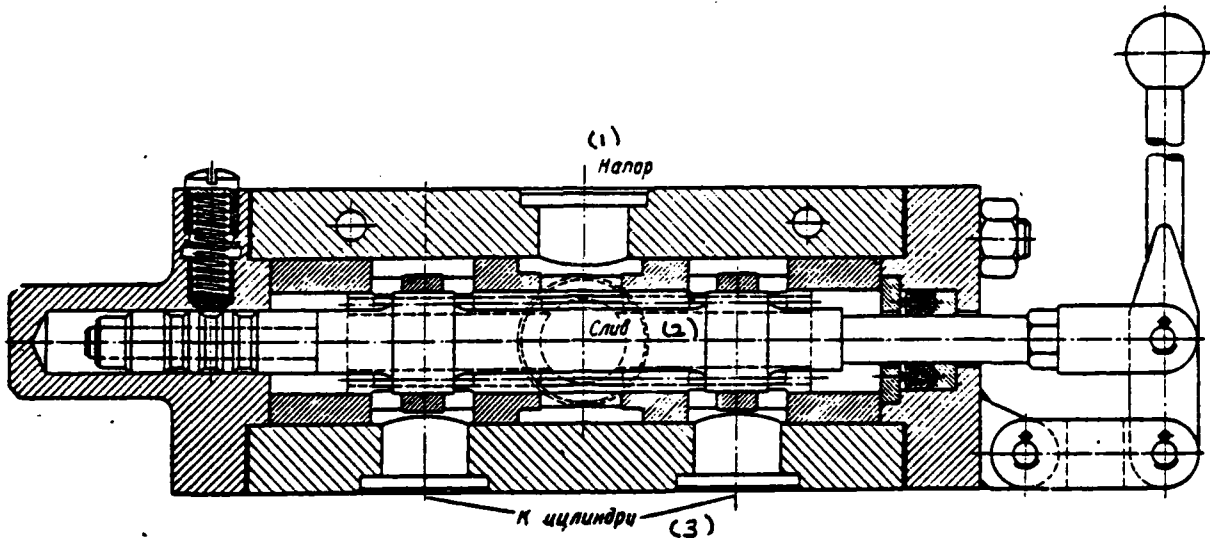

Fig. 361. Valve with the manual displacement.

Key: (1). Pressure. (2). Drain. (3). To the cylinder.

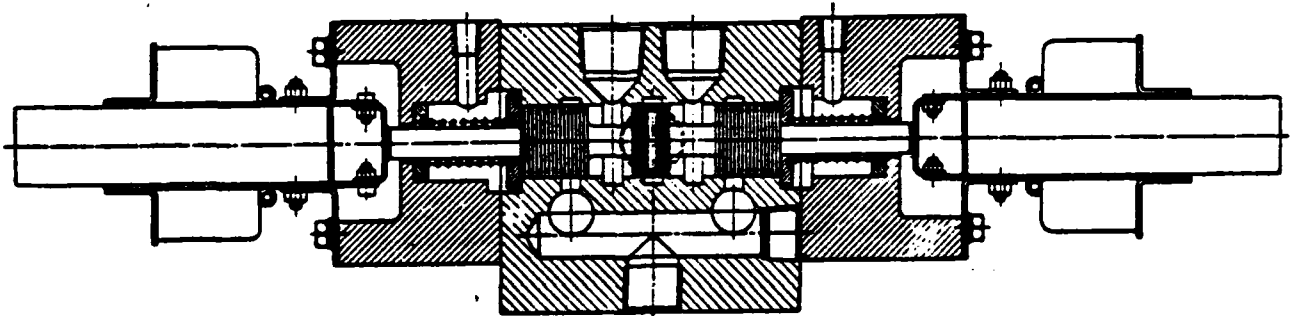

Fig. 362. Valve, moved by electromagnets.

Page 392.

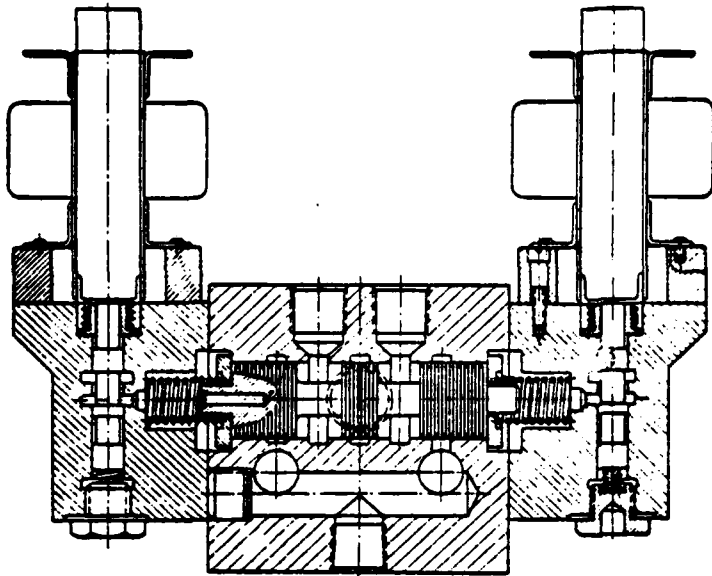

Fig. 363. Valve, moved by oil pressure from the auxiliary network/grid.

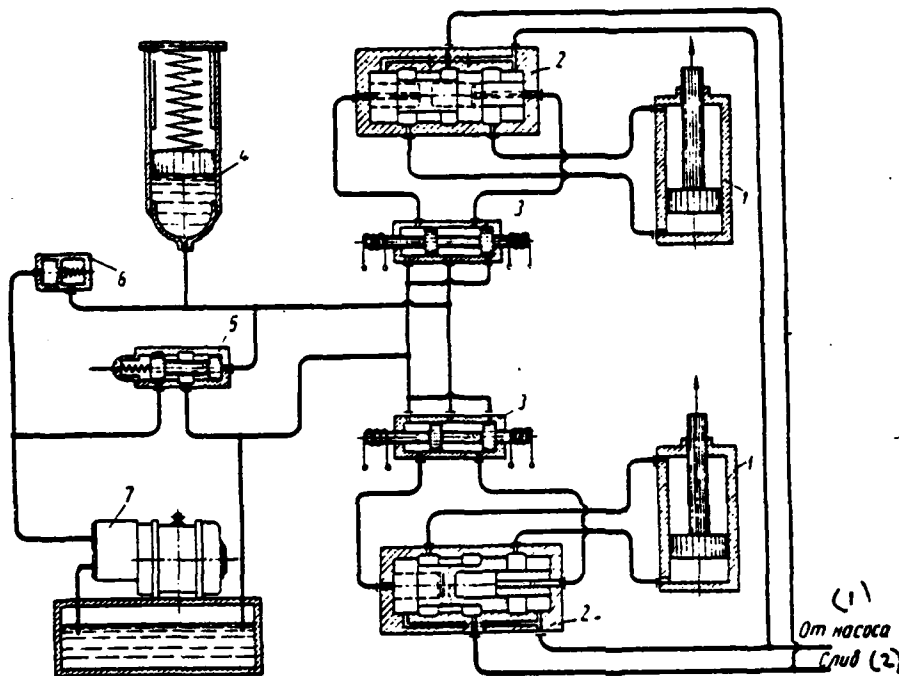

Fig. 364. The hydraulic diagram of control of valves with the use of the spring storage battery/accumulator: 1 - working cylinder; 2 - valve of control of working cylinder; 3 - auxiliary valve with electromagnetic control; 4 - spring accumulator; 5 - idling valve of pump; 6 - check valve; 7 - pump with the electric motor.

Key: (1). From the pump. (2). Drain.

Page 393.

For the displacement of the valves of small sizes/dimensions it

is expedient to utilize the compressed air, since usually the shops, where presses are established/installed, have a supply of air for the production needs. The use of the compressed air makes it possible to create flexible control of press. Auxiliary air equipment has low dimensions and easily it is placed on the control panel.

The construction/design of the valve, moved by the compressed air, it is shown in Fig. 366. To avoid the impacts/shocks of valve, at the end of the stroke against the housing, and also its sharp contact/start from the place, on the exhaust lines from the end cavities of housing installs chokes/throttles. Control of valve is accomplished/realized by an auxiliary valve or slide-valve air distributor.

Valves.

Valves are applied for the dense overlap of high-pressure lines. Sealing/packing/compaction in the valve is accomplished/realized by the flat/plane or conical band, ground/wiped on the saddle. Frequently the valves of one and the same construction/design fulfill different functions and respectively have different designations. In each hydraulic system of press for the purpose of its preservation from the overloading is provided for the valve, which limits the static pressure, for which it is designed.

897

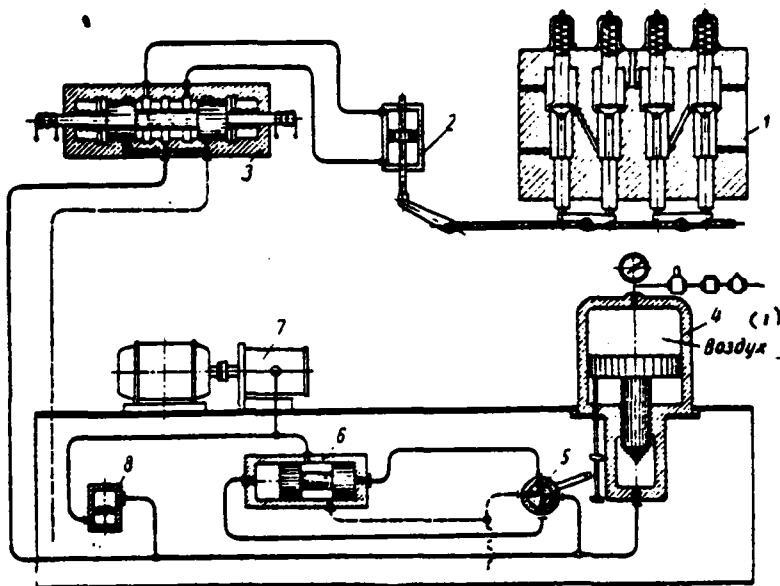

Fig. 365. The hydraulic diagram of control of the valve distributor of powerful/thick press with the use/application of the pneumatic storage battery/accumulator: 1 - valve distributor; 2 - cylinder of the rotation of the shaft of valve distributor; 3 - valve with electromagnetic control; 4 - pneumatic storage battery/accumulator; 5 - plug tap/crane; 6 - idling valve of pump; 7 - pump with the electric motor; 8 - check valve.

Key: (1). Air.

Page 394.

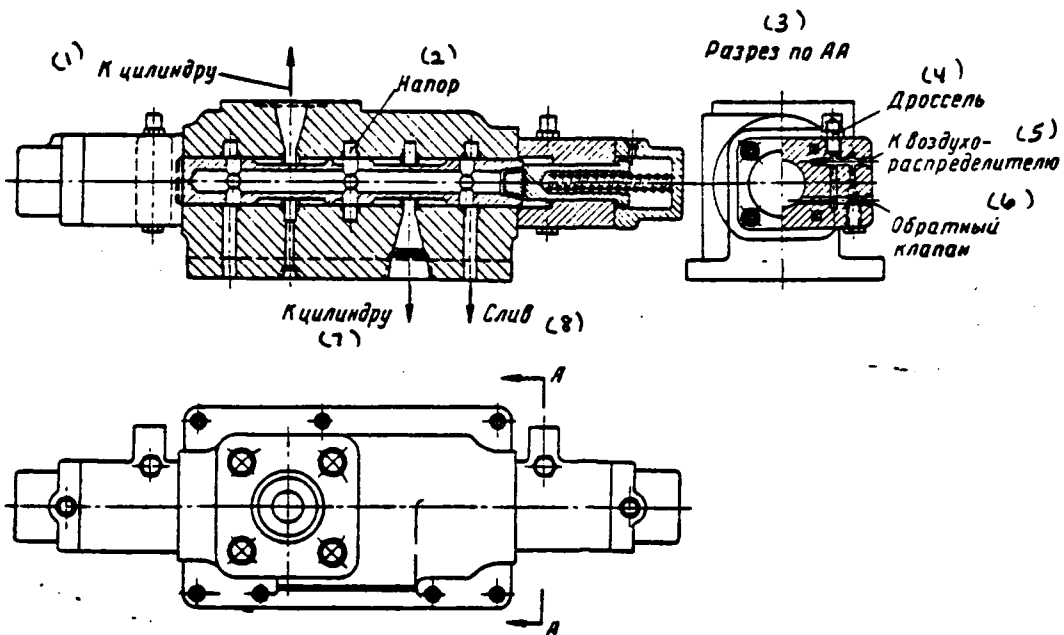

Fig. 366. Valve, moved by the compressed air.

Key: (1). To the cylinder. (2). Pressure. (3). Section AA. (4). Choke/throttle. (5). To the air distributor. (6). Check valve. (7). To the cylinder. (8). Drain.

Page 395.

Such valves, called safety, work short-term.

Sometimes the valves are intended for maintaining the assigned

pressure in the system relatively long time, for example, support valves, valves in the hydraulic systems of punch presses, presses for the extrusion/pressing of plastics, etc.

The action of such valves consists in the fact that at the specific pressure they are opened/disclosed, throwing off liquid to the drain, in this case holding in the system high pressure.

To these valves are presented the following requirements: 1) the density of the overlap of drain line; 2) the precision/accuracy of pressure regulation, i.e., the possibility of the sensitive adjustment of pressure, with which must be opened/disclosed the valve; 3) minimum fluctuation of pressure, during which is opened/disclosed the valve; 4) a minimum change of the pressure in the system depending on the flow rate through the valve; 5) the rapid response of valve, i.e., the quick response to a change of the pressure in the system; 6) the absence of the vibration of valve and noise, caused by this vibration.

The load on the valve, which prevents the course through it of liquid, in different constructions/designs is created differently. In the valves, designed for the small pressures and the flow rates, the load is created by direct effect on the valve of spring.

Ball bearing (Fig. 367) is the valve of this type simplest by the construction/design. The spring, which forces valve against saddle, is designed from the maximum pressure, which affects on the ball/sphere from below. Ball valves more frequently apply as safety ones. They are barely suitable for maintaining the constant pressure in the hydraulic system relatively long time, since it is difficult to adjust them to the specific assigned pressure.

Cylindrical (Fig. 368) or plate (Fig. 369) valves are more advanced. They work with the smaller noise than ball bearing, since they have a direction in the housing or the saddle, and also the cavity in the housing above the valve, filled with oil, which serves as shock absorber.

A shortcoming in the valves examined for the high pressure and the high flow rates is the need of using the strong springs; therefore such valves have limited use/application in the hydraulic systems of presses. The widest use in the presses, which work on oil, received the valves, whose construction/design was shown in Fig. 370.

The load on the valve (Fig. 370), i.e., pressing valve against the saddle, in this construction/design is created a pressure of oil in the cavity above the piston of valve, which is connected by small hole with the forcing line. The pressure, at which the valve is

opened/disclosed, is established by auxiliary ball valve, through which the cavity above the piston of basic valve at the prescribed/assigned pressure is connected with the drain.

Page 396.

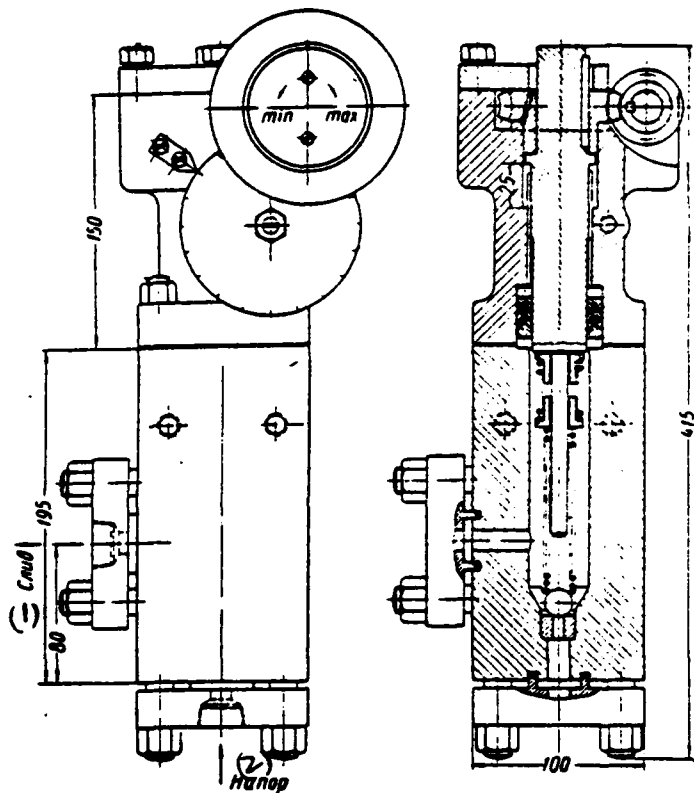

Fig. 367.

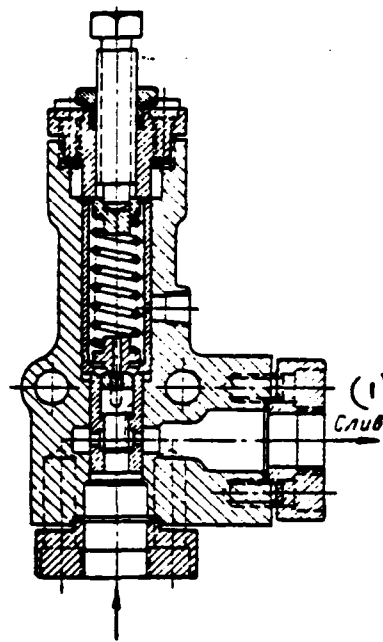

Fig. 368.

Fig. 367. Ball bearing safety valve to the pressure 220 kg/cm².

Key: (2). Drain. (2). Pressure.

Fig. 368. Safety cylindrical valve to the pressure 220 kg/cm².

Key: (1). Drain.

Page 397.

During the discovery/opening of ball valve in the cavity above the piston of basic valve is installed a pressure less in comparison with the pressure in the forcing line on the magnitude of losses of pressure with the course of the liquid within the hole in the piston of low section/cut. Valve is opened/disclosed by a difference in these pressures (under the piston and above the piston), throwing off the main flow of oil to the drain. The relatively larger sizes/dimensions of the piston of the valve provide its high sensitivity, i.e., the possibility of precise pressure adjustment, with which the valve operates/wears. Such valves have small sizes/dimensions, they work noiselessly; pressure in the system, equipped by them, is supported by strictly constant and is easily regulated by the rotation of the screw/propeller, which affects the spring of the auxiliary ball valve.

Jettisoning liquid from the cavity above the piston of valve, for the discovery/opening of the latter, can be accomplished/realized by different devices, which gives the possibility to utilize such

valves for different designations/purposes.

For pressure adjustment in the system during the installation/setting up of pipe valve, assembled on the crown, ball valve can be established/installed on the control panel of the press (Fig. 371a).

In combination with hydraulic terminal switch, one of constructions/designs of which is shown in Fig. 372, valve can serve for limiting the course of the cross-beam of press (Fig. 371b).

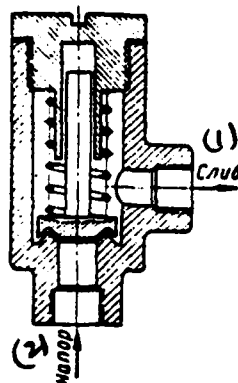

Fig. 369.

Fig. 369. Plate safety valve.

Key: (1). Drain. (2). Pressure.

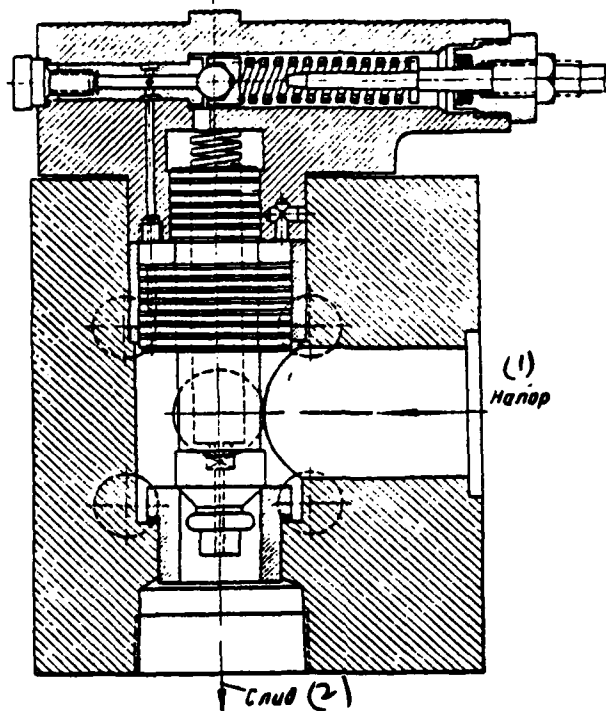

Fig. 370.

Fig. 370. Safety (bypass) valve.

Key: (1). Pressure. (2). Drain.

Page 398.

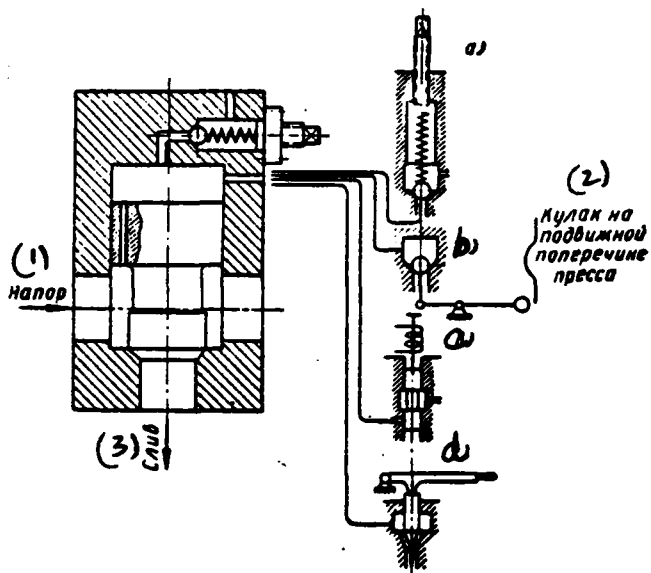

Fig. 371. Schematics of the use of a safety (bypass) valve.

Key: (1). Pressure. (2). Cam on the crosshead of press. (3). Drain.

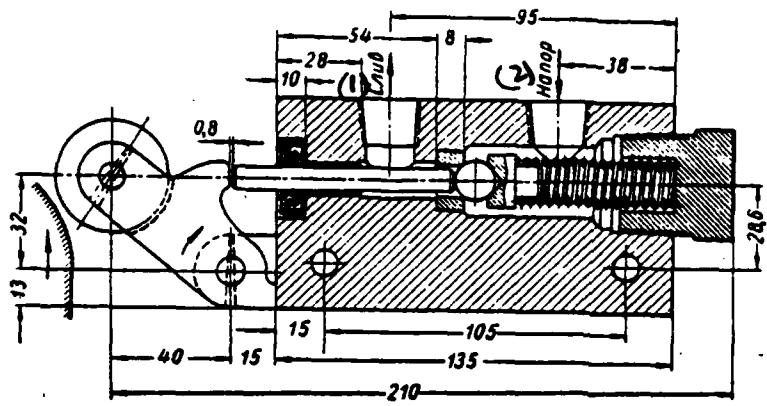

Fig. 372. Hydraulic terminal switch.

Key: (1). Drain. (2). Pressure.

pull-backs.

Page 400.

During the use/application of a valve (or a valve), moved by electromagnet (Fig. 371c), it is easy to carry out electrical valve control.

In combination with the auxiliary choke/throttle (Fig. 371d), valve it is possible to use for throttling/choking the fluid flow from the pump. Are possible many other cases of the use of the construction/design of valve examined. On the wide application of this valve in the hydraulic systems of presses it testifies, for example, the diagram, shown in Fig. 336, in which this valve is used on many lines (pos. 7, 19, 23, 24, 32, etc.).

On the same principle, that also the safety valve examined, design locking and relief valves. The construction/design of this relief valve, used in the hydro-diagram of press by effort/force 2000 t (Fig. 336, pos. 15), it is shown in Fig. 373.

The speed of the action of valve is installed by the appropriate selection of the section/cut of the hole, which connects sub-valve and over-valve cavities. The less this section/cut, the more rapidly

operates/wears the valve during unloading of system (junction of forcing cavity grey) and the slower - during the overlap of line to the drain.

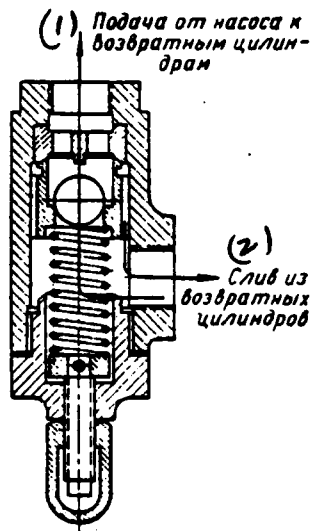

Fig. 375.

Fig. 375. The throttle valve of pull-backs.

Key: (1). Supply from the pump to the pull-backs. (2). Drain from the pull-backs.

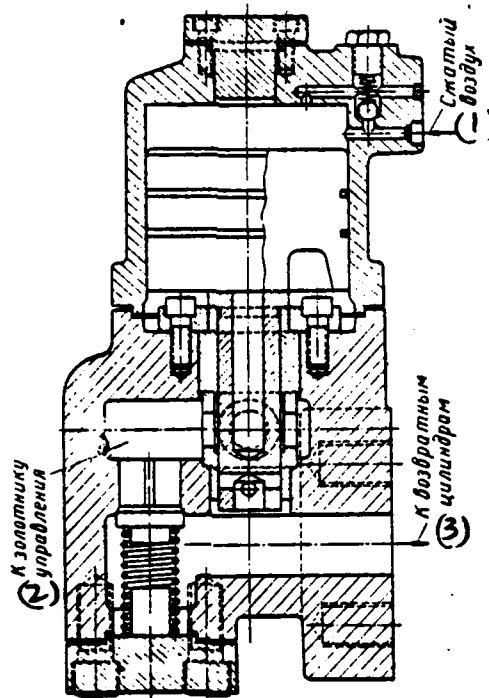

Fig. 376.

Fig. 376. Throttle with the pneumatic load valve for the pull-backs.

Key: (1). Compressed air. (2). To the valve of control. (3). To the pull-backs.

Page 401.

For the preservation from the arbitrary dropping of the crosshead, during the control of press by slide-valve distributors, for the dense overlap of line from the reverse/inverse cylinders to the drain apply plate or cylindrical valves; one of the constructions/designs of this valve is shown in Fig. 374.

For the retarded motion of cross-beam down with the idling are applied the combined valves with the free duct of oil, supplied with pump to the pull-backs during the course of cross-beam upward (during the low resistance) and throttling/choking of flow with the oil drain from the cylinders. Examples of the constructions/designs of such valves are shown in Fig. 375 and 376.

Pressure relay.

One of the positive special features/peculiarities of batteryless pumping drive is the possibility of using the pressure in the separate components/links of hydraulic system for switching of control of the press. For these purposes the pressure relay, in which moving working element/cell at the specific prescribed/assigned

pressure closes the electrical terminal switch, which affects the appropriate electrical apparatus in the hydraulic system, is applied. With the aid of the pressure relay in many presses the automatic changeover of press to the recurrent course, when pressure in the working cylinders reaches maximum, is accomplished/realized. In the presses with several steps/stages of the efforts/forces of pressure relay it is utilized for the automatic series connection of the control devices of cylinders; for example, in the three-cylinder press the start of two outer cylinders is accomplished/realized automatically on the impulse/momentum/pulse of pressure relay, supplied upon reaching/achievement of maximum pressure in the pitch cylinder. Are possible other most varied cases of use by pressure relay.

Examples of the constructions/designs of relay are shown in Fig. 377 and 378. In the construction/design Fig. 377 unbalanced valve 1 serves as mobile operating unit, which affects electrical terminal switch. The pressure, applied into the working cavity of relay, acting on the band of valve with the area $\pi/4(25^2-24^2)$, overcomes resistance of tightened spring 2, valve is moved and closes terminal switch 3.

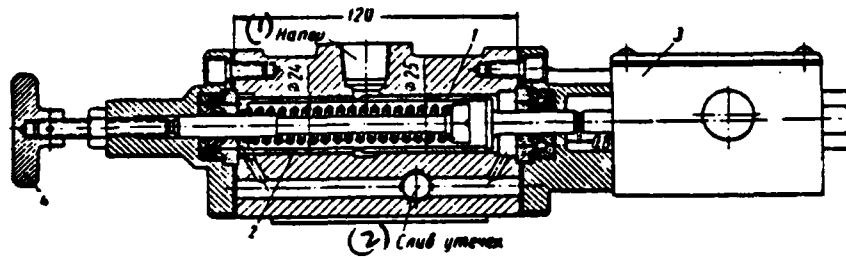

Fig. 377. Pressure relays with the stepped valve on the pressure 220 kg/cm² for the work on oil: 1 - valve; 2 - spring; 3 - terminal switch; 4 - adjusting wheel of pressure.

Key: (1). Pressure. (2). Drain of leaks/leakages.

Page 402.

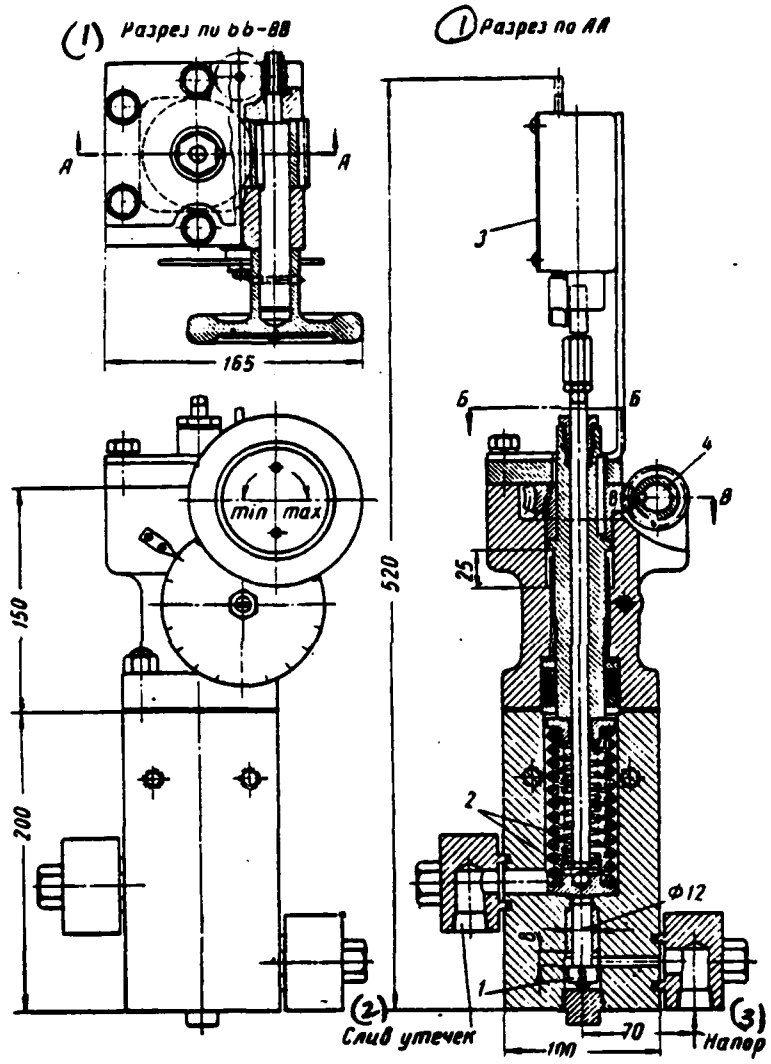

Fig. 378. Pressure relays with the plunger on the pressure 220 kg/cm² for the work on oil: 1 - plunger; 2 - load springs; 3 - terminal switch; 4 - mechanism for the tightening of springs.

Key: (1). Section/cut on (2). Drain of leaks/leakages. (3).
Pressure.

Page 403.

Pressure regulation, with which the relay operates/wears, is accomplished/realized by tightness of spring 2.

In the relay shown in Fig. 378, plunger 1 ground/wiped in the housing serves as working mobile organ/control.

Distributing valve devices.

When in system the storage battery/accumulator of high-pressure liquid is present, the line between the storage battery/accumulator and the press is found constantly under high pressure. The velocities of transfer plungers can be regulated only by a change of the resistance in the line storage battery/accumulator - press or, in other words, by throttling/choking working fluid flow. The special features/peculiarities of the pump-and-battery drive indicated cause those determined requirements to the elements of control of presses. Constant pressure in the distributor of press causes the need for the dense overlap of forcing line. Throttling/choking the flow of the working fluid of water causes the need of applying the noncorrosive

materials. For the control of presses with the pump-and-battery drive valve distributors are applied mainly. Slide-valve distributors during this drive are encountered very rarely (for the small flow areas).

In the distributors in the overwhelming majority saddle-like valves with the conical sealing band are applied. In certain cases for the control of the auxiliary mechanisms, which expend small amount of liquid, apply ball valves (Fig. 379). Such valves are simple in the manufacture, but they have a shortcoming - severe vibration and a noise with the work.

Depending on designation/purpose, and also rate of flow and pressure of liquid the valves are made different construction/design.

For the large flow passage cross sections the valves are made with the preliminary unloading from the effort/force to the valve, accomplished by the pilot valve of low section/cut, built in the housing of base. Frequently the valves are made by those balanced, i.e., such construction/design, during which high-pressure liquid in the cavity above the valve creates insignificant effort/force to the valve.

Fig. 380 shows the construction/design of the valve without the

unloading, used in the distributors with the small flow areas.

In the closed position the valve is clamped by the effort/force, which is created a pressure of liquid p_a on the valve and action of spring with the effort/force Π :

$$P = \frac{\pi d^2}{4} p_a + \Pi.$$

During the determination of the effort/force, necessary for the valve lift, should be considered the friction of valve stem against the packing gland.

Page 404.

If we accept the common gear ratio between the control handle and valve stem equal to 1:25 and to allow force on the control lever of 8 kg, then it is possible to determine the maximum valve diameter without the unloading.

Disregarding the force of spring and the friction of valve stem against the sleeve, we will have a relationship/ratio

$$\frac{\pi d^2}{4} p_a = 8 \cdot 25.$$

At a pressure of working fluid 200 kg/cm² the diameter of valve will be equal to

$$d = \sqrt{\frac{800}{3,14 \cdot 200}} = 1,1 \text{ cm.}$$

Thus, calculation shows that the valves without the unloading

can be used only for the auxiliary distributing valve devices with the small flow areas or for the distributors of the slow presses, when the larger gear ratio between valve stem and control lever can be accepted.

Fig. 381 shows the construction/design of valve with the preliminary unloading, accomplished by a pilot valve.

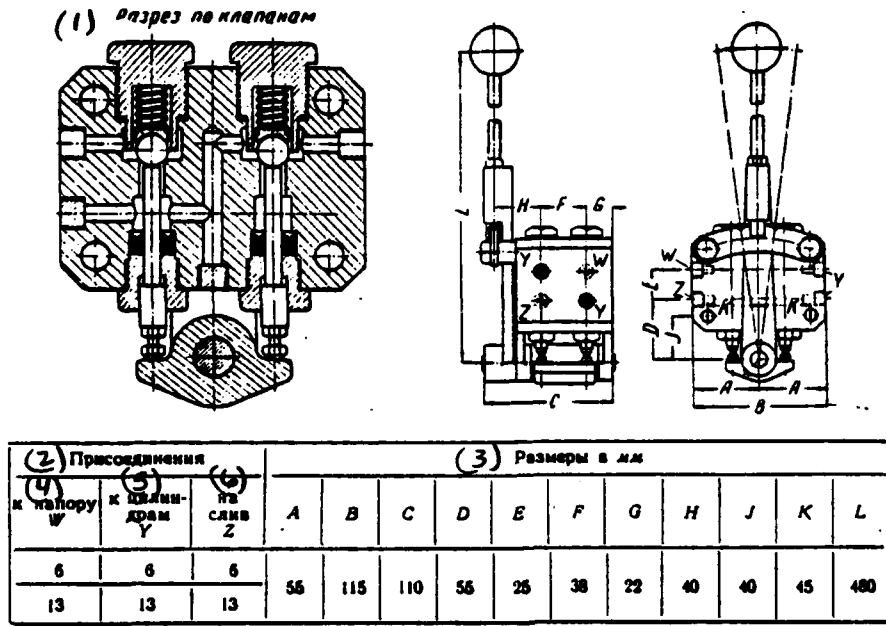

Fig. 379. Construction/design and the basic dimensions of distributor with ball valves.

Key: (1). Section/cut on the valves. (2). Attachments/connections. (3). Sizes/dimensions in mm. (4). to pressure W. (5). to cylinders Y. (6). to drain Z.

Page 405.

After the discovery/opening of pilot valve the pressure above the valve and under it is aligned, after which for lifting the basic valve the relatively small effort, equal to the effort/force,

necessary for compression of spring and overcoming of the friction of stock/rod in the sealing sleeve is required.

Fig. 382 shows another most widely used construction/design of valve with the preliminary unloading, in which the stock/rod of the lift of basic valve and pilot valve are carried out as one whole.

In this case the effort/force for the discovery/opening of pilot valve is equal

$$P = \frac{\pi}{4} (d^2 - d_1^2) \rho_s + T + \Pi,$$

where T - force of friction in the sleeve;

Π - effort/force of spring.

Expression $\pi/4(d^2 - d_1^2)$ must be equal to the area of the condensed band of pilot valve or, in other words, the diameter of stock/rod d_1 must be equal to the diameter of passage section/cut d_1 .

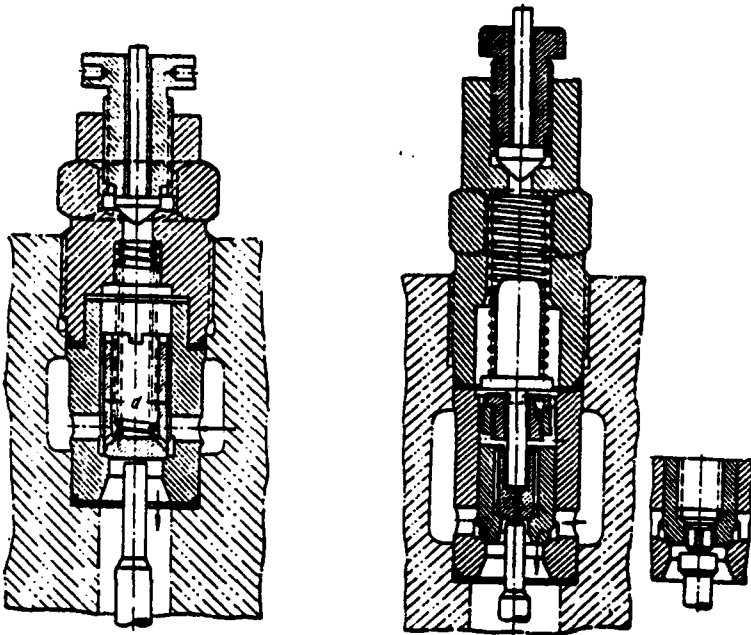

Fig. 380.

Fig. 381.

Fig. 380. Cylindrical valve without the preliminary unloading.

Fig. 381. Cylindrical valve with the preliminary unloading.

Page 406.

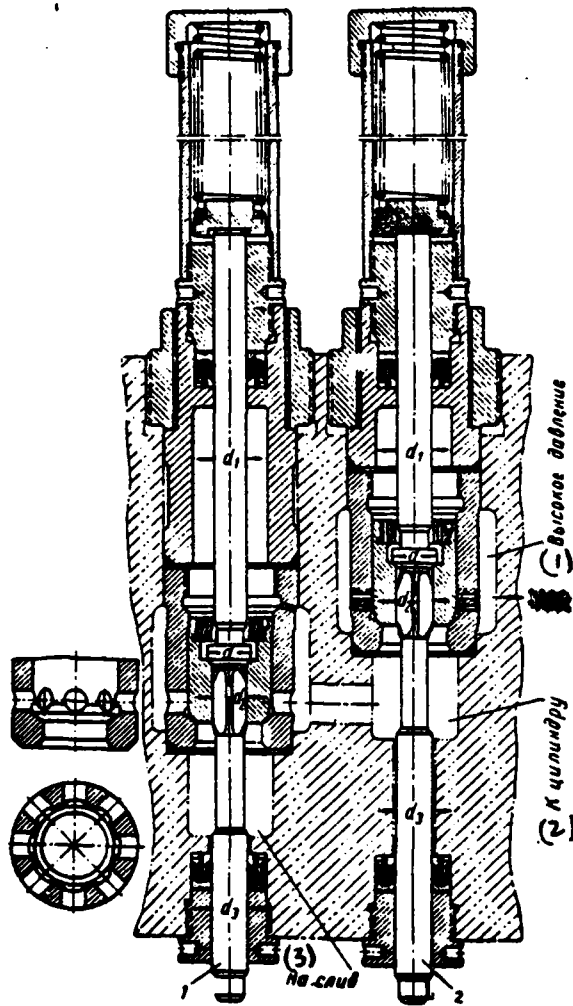

Fig. 382. The extended construction/design of valves with the preliminary unloading: 1 - drain valve; 2 - pressure valve.

Key: (1). High pressure. (2). To the cylinder. (3). To the drain.

Page 407.

In the case of accomplishing the stock/rod with the diameter, large how d_1 , can seem that it will move away valve from the saddle and pass liquid. The phenomenon indicated can be in such a case, when band is ground/wiped with "one line" at the apex of the cone, as shown in Fig. 383, and it will press to the condensed band from below liquid.

The necessary condition is also the equality of the diameters of the ends of the stock/rod, i.e., $d_1 = d_2$.

With accomplishing of the diameter of the end of stock/rod $d_1 < d_2$, the spring must be designed for the additional effort/force, equal to $\pi/4(d_2^2 - d_1^2) p_{cr}$ since in this case with the open valve the effort/force, which affects upward on the stock/rod will appear.

But if we accept $d_1 > d_2$, then with the open valve will appear the additional effort/force, which affects down on the stock/rod, for compensation for which additional force feel is necessary.

During the use/application of valves with the unloading is required for a while for the pressure balance under the valve and above it, which decreases rapidity of press. Therefore the valves of

powerful/thick presses with the large passage cross sections (from 50 mm and above) frequently are made with the dual unloading, i.e., they build in into the basic valve two pilot valves, which are opened consecutively/serially (Fig. 384).

The absence in their upper cavities of air release valves is a shortcoming in the construction/design of the valves with the unloading, shown in Fig. 382 and 384.

The construction/design of valve with the unloading, in which relief valve is carried out together with the stock/rod for the valve lift and in its upper sleeve/beaker is placed air release the valve, it is shown in Fig. 385.

A shortcoming in the construction/design of this valve is the fact that for its lift the effort is required, larger than in the preceding case, to the value, equal to $\frac{\pi d_i^2}{4} p_e$.

Fig. 386 shows the construction/design of equilibrated valve.

During this construction/design of equilibrated valve the effort/force for its lift is equal to the product of the area of sealing band to the pressure in the cavity above the valve, force of the pressure of spring and force of friction in the sealing sleeves.

The sizes/dimensions two- and four-valve distributors with the equilibrated valves with flow areas of 13-40 mm are shown in Fig. 387 and 388.

In the presses with the large efforts/forces frequently are applied the valves, whose construction/design is shown in Fig. 389.

In this case the valve lift is accomplished/realized by pressure of liquid on the end/face of the valve with a diameter of d_2 , and the clamp of valve to the saddle is accomplished/realized by pressure of liquid on its upper annulus, equal to $\pi/4(d_2^2 - d_1^2)$.

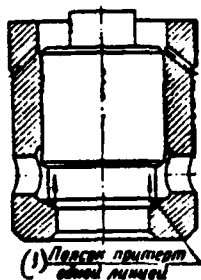

Fig. 383. Incorrect valve setting to the saddle.

Key: (1). Band is ground/wiped with one line.

Page 408.

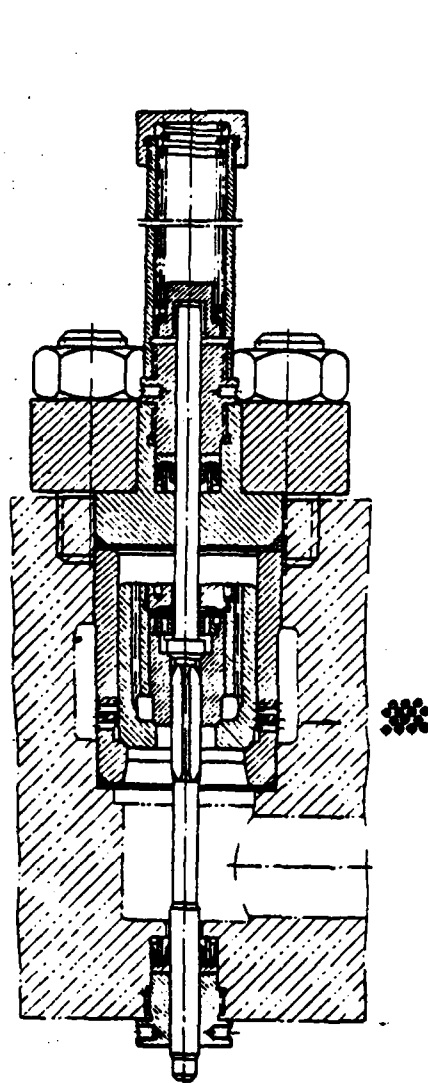

Fig. 384.

Fig. 384. Extended construction/design of valve with the dual unloading.

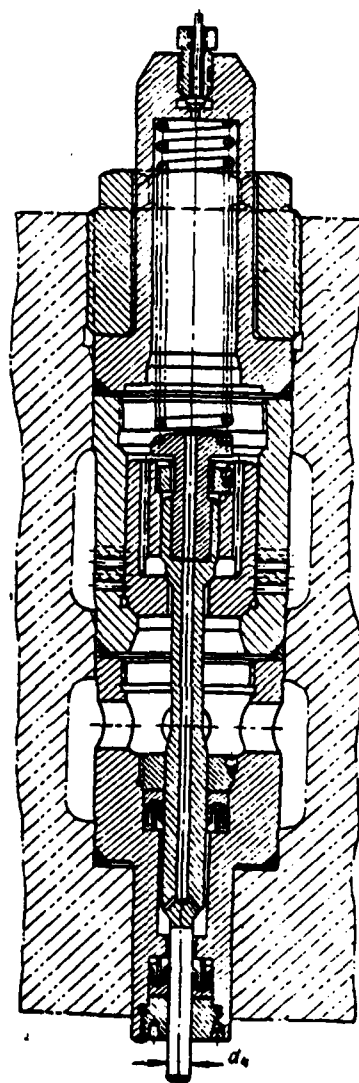

Fig. 385.

Fig. 385. Cylindrical valve with the unloading.

Page 409.

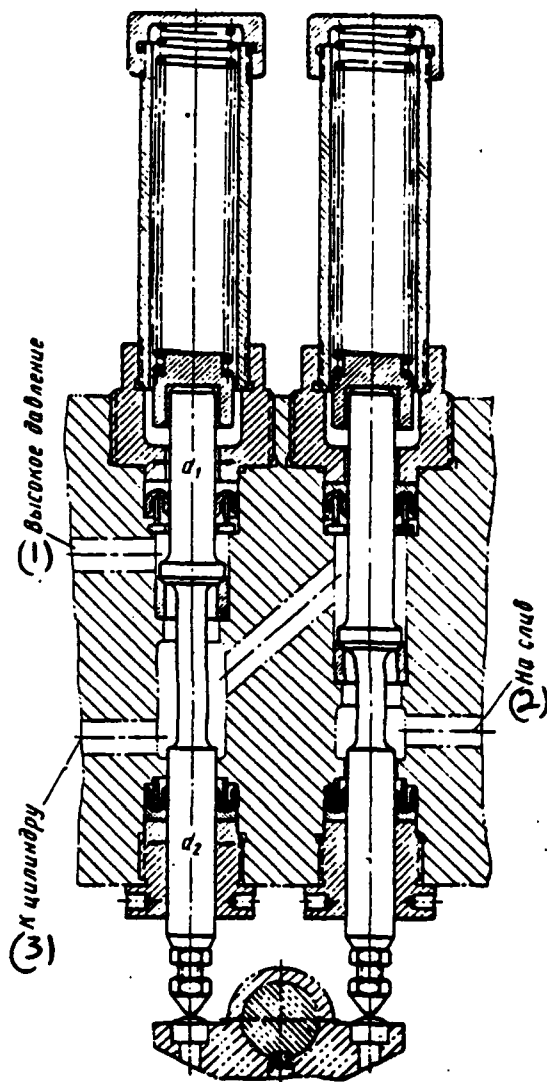
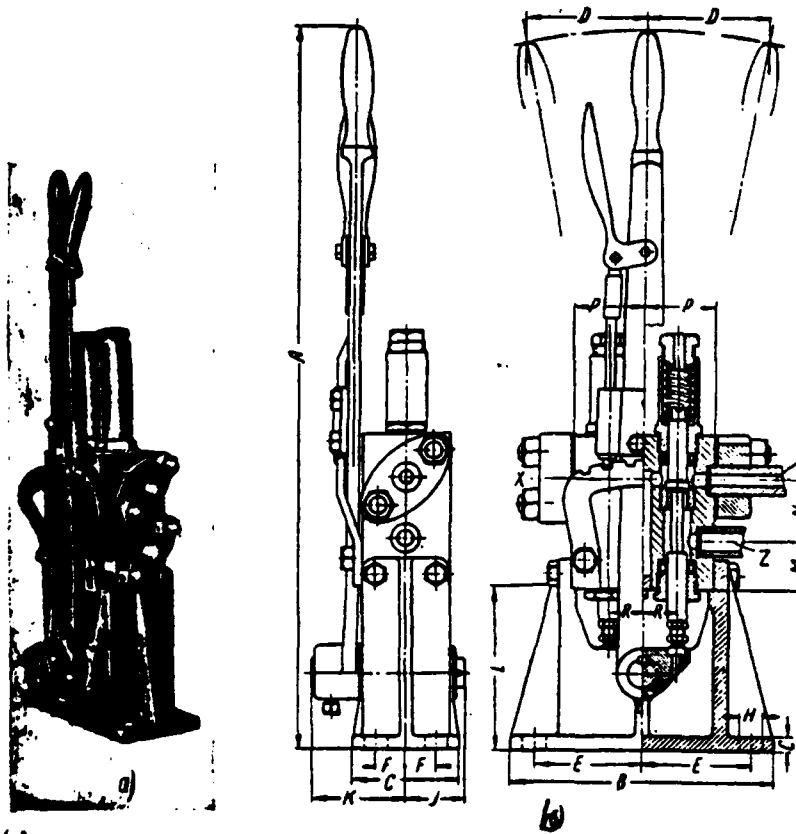

Fig. 386. Construction/design of equilibrated valves.

Key: (1). High pressure. (2). To the drain. (3). To the cylinder.

Page 410.



(1) Присоединение			(5) Максимальное давление в кг/см ²	(2) Размеры в мм.														
(3) к напору X	(4) к центру яндрю Y	(5) на слав Z		A	B	C	D	E	F	G	H	J	K	L	M	N	P	R
13	13	13	320	685	250	100	115	100	30	12	22	60	90	150	40	60	65	32
20	20	20	320	685	250	100	115	100	30	12	22	60	90	150	50	60	65	32
25	25	25	200	685	250	100	115	100	30	12	22	60	90	150	50	60	65	32
32	32	32	200	645	285	140	140	120	50	16	22	75	125	200	60	60	80	45
40	40	40	200	1000	325	180	140	140	65	18	25	75	130	200	65	65	100	55

Fig. 387. Exemplary/approximate construction/design and the sizes/dimensions of distributor with two equilibrated valves: a)

appearance; b) general view drawing.

Key: (1). Attachment/connection. (2). Sizes/dimensions in mm. (3). to pressure X. (4). to cylinder Y. (5). to drain Z. (6). Maximum pressure in kg/cm².

Page 411.

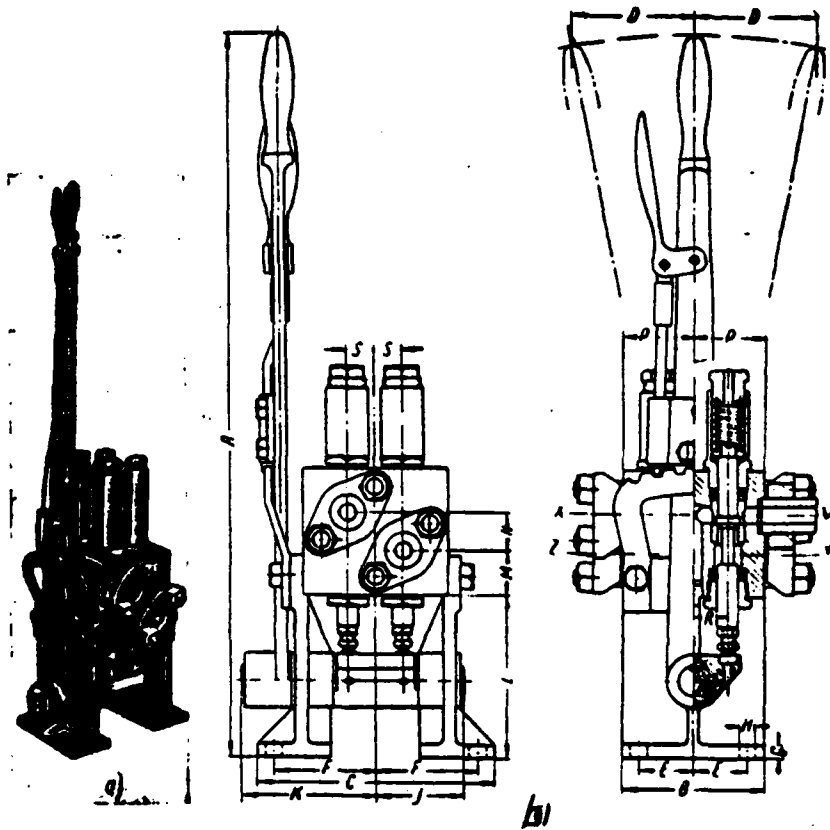

1) Присоединение					2) Размеры в мм																
к шарову W	к шарову X	к шарову Y	к шарову Z	Максимальное давление в кг/см²	A	B	C	D	E	F	G	H	J	K	L	M	N	P	R	S	
13	13	13	13	320	685	136	220	115	45	90	12	28	85	130	150	45	35	65	32	25	
25	25	25	25	320	845	136	220	150	45	90	12	20	85	170	150	45	35	65	32	25	
32	32	32	32	200	845	136	220	150	45	90	12	20	85	170	150	45	35	65	32	25	
40	40	40	40	200	1000	180	310	165	60	135	16	22	110	170	200	55	60	90	45	35	
50	50	50	50	200	1160	200	320	190	80	135	16	22	115	180	200	65	65	100	55	35	

Fig. 388. Exemplary/approximate construction/design and the sizes/dimensions of distributor with four equilibrated valves: a)

appearance; b) drawing of general view.

Key: (1). Attachment/connection. (2). Sizes/dimensions in mm. (3). to cylinder (4). to pressure X. (5). to drain Z. (6). Maximum pressure in kg/cm².

Page 412.

During this construction/design of valve it is necessary to have the following relationship/ratio of sizes/dimensions $(d^2, -d^2_1) < d^2;$ $d_1 > d_1.$

Control of these valves is accomplished/realized by the auxiliary distributors, frequently installed on the housing of basic distributor. Fig. 390 shows construction/design and are given the overall dimensions of distributors with similar valves, but with the spring load and with flow areas of 50-100 mm.

In the presses with the large efforts/forces received also propagation the so-called "floating" valves (Fig. 391). Basic valve with large passage cross section copes by the pilot valve, whose discovery/opening is accomplished/realized by a pusher. During the discovery/opening of pilot valve the cavity above the basic valve is connected with the drain, as a result of which it surfaces under the

effect of pressure, which affects from below on the unbalanced part of the valve. During the coverage of pilot valve the pressure in the cavity above the basic valve is built up, and it is set on its saddle.

Valves and their saddles are manufactured at not less than 30 kgf/mm² of solid stainless steel or from the solid bronze with compressive strength during contraction by ~20%.

The sealing edge of valve usually is made with angle of 45°; its width is determined from the permissible specific pressure, taken to the equal to 800-1000 kg/cm².

For the best sealing/packing/compaction against the leaks/leakages of liquid sometimes in the valve, designed for the pressure to 200 kg/cm², are applied soft ring from the skin or rubber (Fig. 392). In this case so that the ring very rapidly was not destroyed from the effect of fluid flow, valve stem is made with the band, which, going in the hole of valve seat, stops fluid flow, before soft ring it will sit down on the saddle.

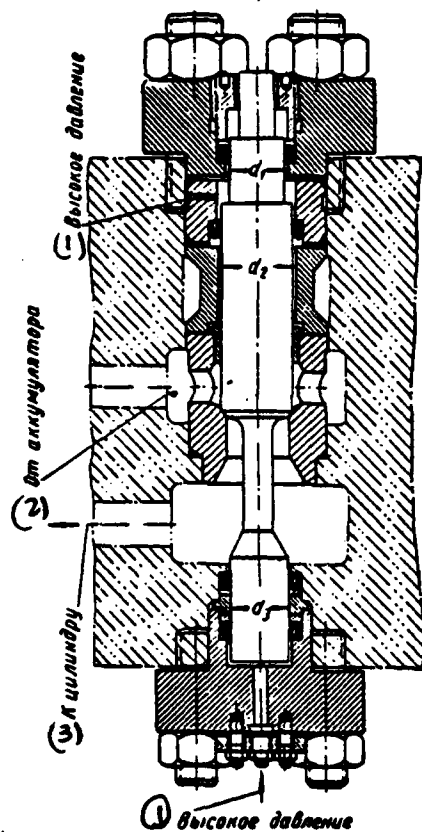

Fig. 389. Valve, which is opened/disclosed (closing) by the pressure of liquid.

Key: (1). High pressure. (2). From the storage battery/accumulator.
(3). To the cylinder.

Page 413.

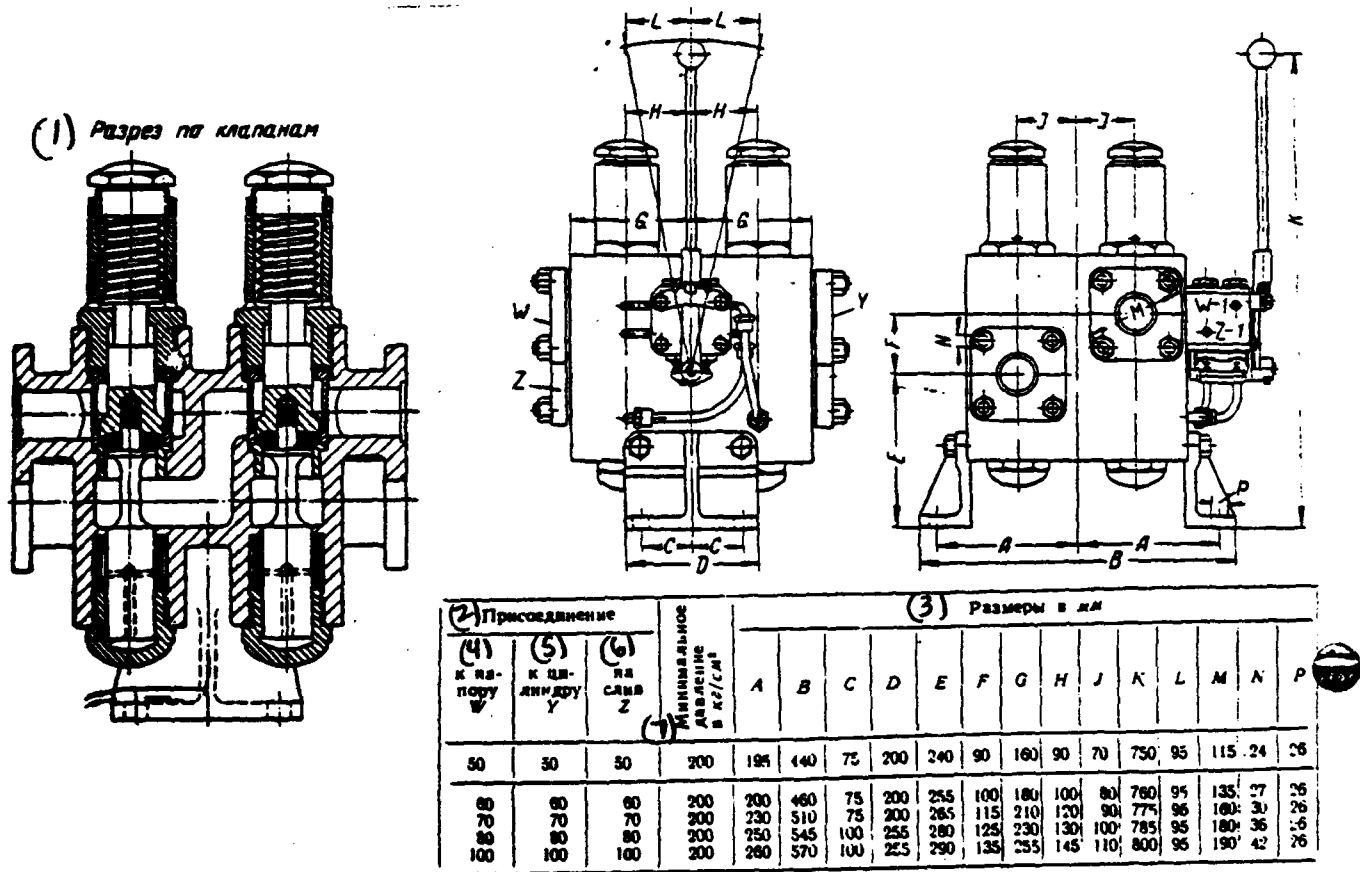

Fig. 390. Exemplary/approximate construction/design and the sizes/dimensions of four-valve distributors.

Key: (1). Section/cut on the valves. (2). Attachment/connection. (3). Sizes/dimensions in mm. (4). to pressure W. (5). to cylinder Y. (6). to drain Z. (7). Minimum pressure in kg/cm².

Page 414.

The value of valve lift can be calculated on relationship/ratio $h=0.3d$. With the high value of lift take place of valve against saddle and damage of the ground/wiped band on the valve and the saddle. The height/altitude of valve must be equal to not less $1.5d$. Not more than $0.05-0.1$ mm is accepted as the clearance between the valve and the guiding sleeve/beaker. Passage openings in the guiding sleeves/beakers of valves are selected depending on the designation/purpose of valve and velocity of the motion of transfer plunger. For the intake high-pressure valves these holes are usually selected by equal to $(0.75-0.8)f$ (where f - area of connecting conduit/manifold) and they furnish in 3-4 series/rows.

They usually furnish the holes of the sleeves/beakers of drain valves in one series/row and make with the large cross sections.

In order to have slow banking of valve, communication/report to forcing line with the cavity above the valve in the bleeder valves is accomplished/realized only through the clearance between the valve and the guiding sleeve/beaker; in the drain valves these cavities are imparted by means of the hole, drilled in the sleeve/beaker.

The valves usually are opened/disclosed with the aid of

stock-pushers, driven from camshaft, on which the hammers/cams or yokes/arms are installed. Camshaft is rotated with the aid of the lever, by hand or with the aid of the special mechanism, which facilitates the work of operator.

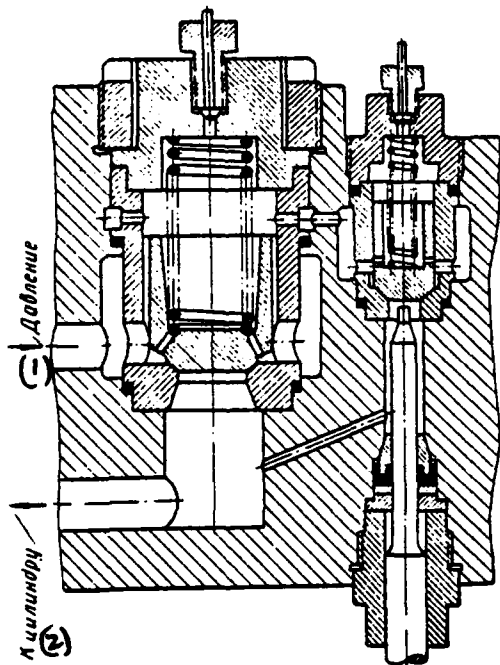

Fig. 391.

Fig. 391. Construction/design of the "floating" valve.

Key: (1). Pressure. (2). To the cylinder.

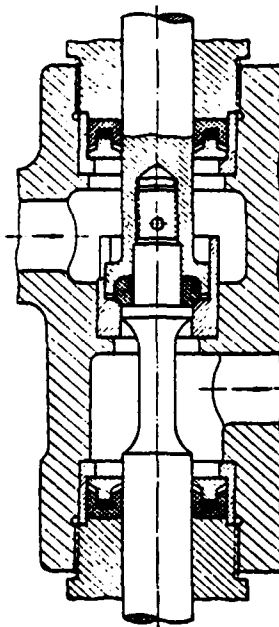

Fig. 392.

Fig. 392. Valve with soft ferrule.

Page 415.

The example to the constructions/designs of manual hoisting

device of valves is shown in Fig. 393. During hand reversing gear the effort/force to the lever must be as small as possible. The length of control lever is usually taken as the equal to 700-1000 mm. The cast or welded frame, on which the sector for the fixation of the specific positions of lever is fastened serves as support for camshaft and valve box.

For the powerful/thick and high-speed presses manual lever control of valves with the large efforts/forces on the lever and with the large angle of rotation of lever cannot ensure the necessary number of strokes of press. Therefore powerful/thick presses are supplied with auxiliary mechanisms for the rotation of the shaft of distributor or valve lift in them is accomplished/realized not by pushers, but by high-pressure liquid, as shown in Fig. 389.

As the auxiliary mechanisms pneumatic or hydraulic cylinders, rotational hydraulic motors with the feeding from rotary pump, etc are applied also.

Fig. 394 shows the construction/design of the distributor, in which the shaft is given from the pneumatic cylinder. Control of cylinder is accomplished/realized from rotary valve (Fig. 395).

AD-A139 822

HYDRAULIC PRESSES(U) FOREIGN TECHNOLOGY DIV
WRIGHT-PATTERSON AFB OH B V ROZANOV 09 MAR 84
FTD-ID(RS)T-1207-83

10/10

UNCLASSIFIED

F/G 13/9

NL



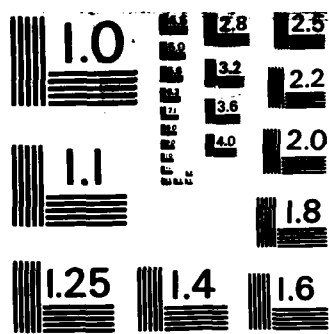

MICROCOPY RESOLUTION TEST CHART
NATIONAL BUREAU OF STANDARDS-1963-A

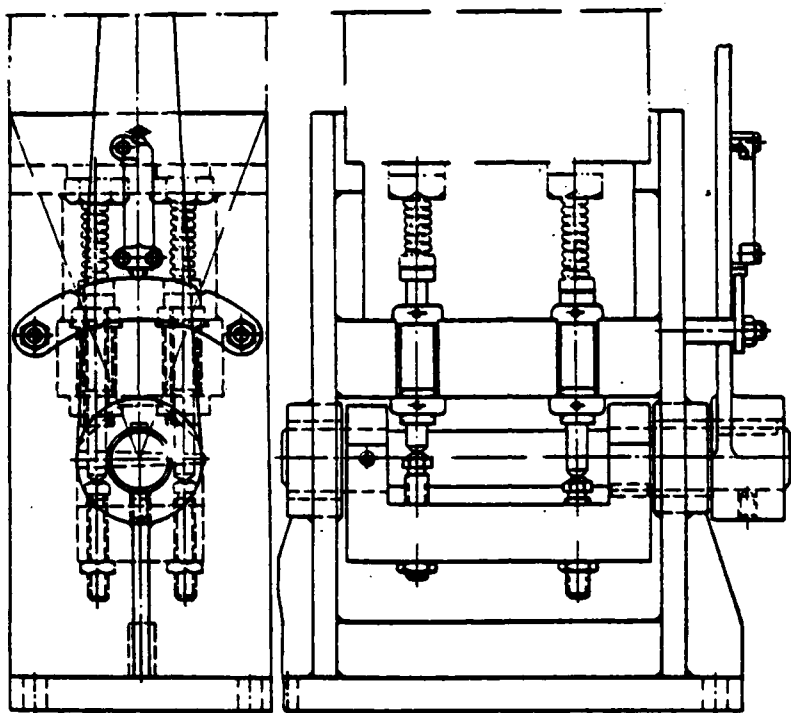

Fig. 393. Construction/design of hoisting device of valves.

Page 416.

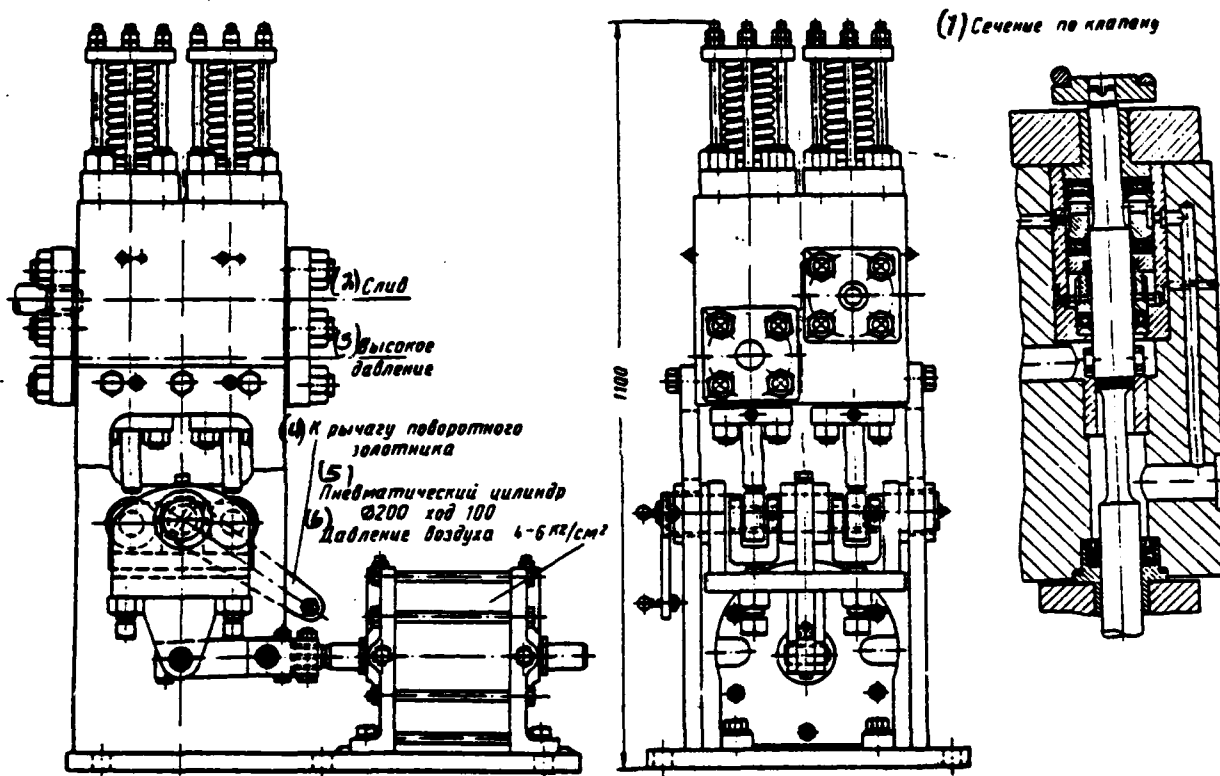
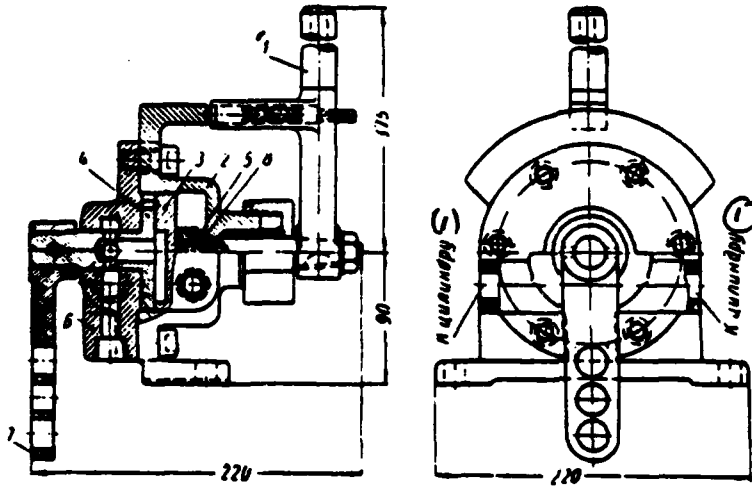

Fig. 394. Distributor with the pneumatic cylinder for valve lift.

Key: (1). Section/cut throughout the valve. (2). Drain. (3). High pressure. (4). To the lever of rotary valve. (5). Pneumatic cylinder $\phi 200$ course by 100. (6). Air pressure 4-6 kg/cm².

Page 417.

The rotation of the lever of this valve to the specific angle causes the necessary progressive/forward displacement of air piston. The work of rotary valve is accomplished/realized as follows. In housing 2 (Fig. 395a) slide valves 3 and 4 are built in. Valve 3 is connected with the aid of shaft 8 with the control handle 1, while valve 4, which rotates in the cover/cap of housing 6, is connected with lever 7, which, in turn, is connected with the shaft of distributor. In the initial position of lever the channels B and Γ (Fig. 395b) valve 4 are overlapped by valve 3, spring-loaded 5, and air, applied along channel m, proves to be in the closed cavity of housing 2. The cavities of housing, connected with the pneumatic cylinder, are also overlapped, since the channels K and Π are overlapped by valve 3.



a)



b)

Fig. 395. Pneumatic rotary valve.

Key: (1). to the cylinder.

Page 418.

During the rotation of lever 1 to any side, for example to itself, the channel B will partially overlap the channel Г of valve 4, in consequence of which the cavity of housing, filled with air, will be connected through the holes B, Г, Д with the cylinder, piston rod of which by rod/thrust is connected with lever 7. With the piston stroke lever 7 will be turned until valve 4 overlaps hole B.

Another cavity of cylinder during the rotation of lever 1 to itself will be connected through the holes K and B and further through valve 3 (slot A) and holes Д, E and Ж with the atmosphere.

Thus, to the specific position of lever 1 they will correspond to the specific displacement of piston and respectively valve opening of distributor.

Fig. 396 shows installation for rotating the shaft of distributor with the rotational hydraulic motor, given by blade oil pump. The construction/design of hydraulic motor is shown in Fig. 397. Hydraulic motor consists of dismountable housing with flanges 10 and 11, cylinder 13 and block 12, which divides the working cavities of motor.

In the housing of motor is a bushing 7, to which block 9 is fastened/strengthened. This block performs the role of piston. On bushing 7 from the end/face power lever 8 is fastened. Bushing 7 is connected with bushing 14, which has internal helical thread.

Valve 4 is rigidly connected with bolts 2 and 3 with the control lever 1 and has also helical thread 5, which enters into engagement with the thread of bushing 14. The installation of valve is produced so that the clearances between valve 4 and its bushing 6 would be equal to approximately $n \approx k \approx 1$ mm and $l \approx u \approx 0.75$ mm.

Oil from the pump is fed into the cavity A. Cavities B and Д are connected with the drain. Cavity Г is connected with the cavity M, while cavity Б is connected with the cavity of H.

In the free position of control lever 1 oil from pump comes into cavity a, whence it passes through clearances l and u in the cavity Г and Б are further through the clearances И and К it falls on drain.

During the translation/conversion of lever 1 into itself valve 4 will begin to be turned and, relying on helical thread 5, it will be

misaligned it will to the right and select clearances Π and u . After this oil from the pump it will pass from the cavity A through the increased clearance E into the cavity Γ and further into the cavity M , producing pressure on block 9. Block will begin to be turned together with bushing 7 and sitting on it power lever 8. In this case their cavity of hennas available in it oil will be extruded into the cavity B through the clearance K into the cavity B and to the drain.

With the stop of control lever 1 bushing 7 at the first moment/torque will continue its rotation, also, through engagement 5 move valve 4 until clearances Π and K are equalized.

The given construction/design makes it possible to develop considerable efforts/forces on lever 3, connected with the shaft of the distributing valve device of press, during the virtually identical rotations of this lever and control lever 1, for rotation of which it is not required large efforts/forces.

Page 419.

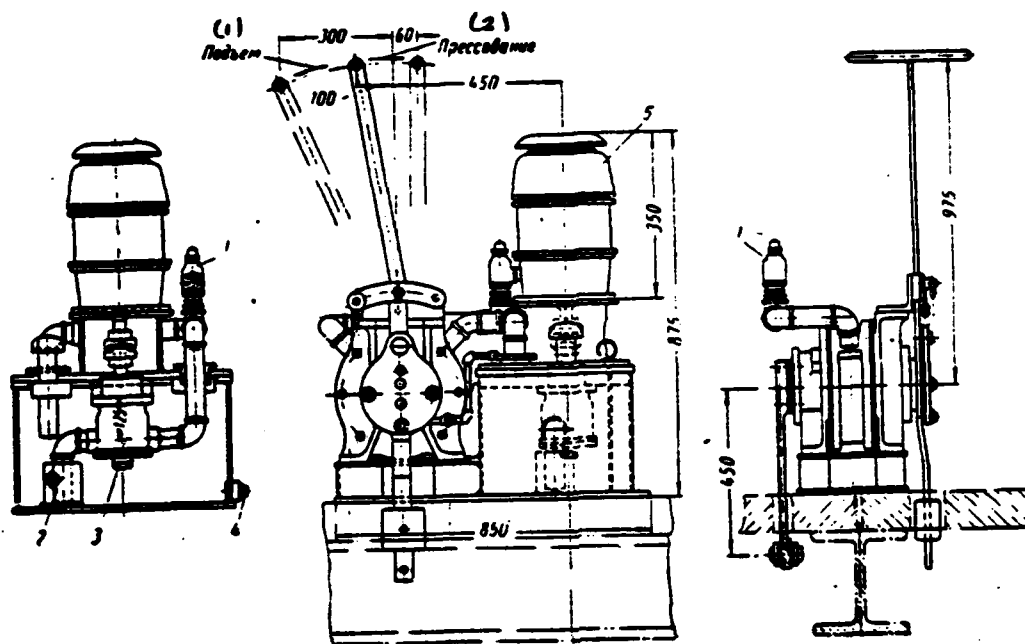

Fig. 396. Installation with the rotational hydraulic motor for rotating the shaft of the distributor: 1 - safety valve; 2 - filter; 3 - rotary pump with the supply 165 l/min to the pressure 6 kg/cm²; 4 - plug for the drain; 5 - electric motor with a power of 2 hp with 1140 r/min.

Key: (1). Lift. (2). Extrusion/pressing.

Page 420.

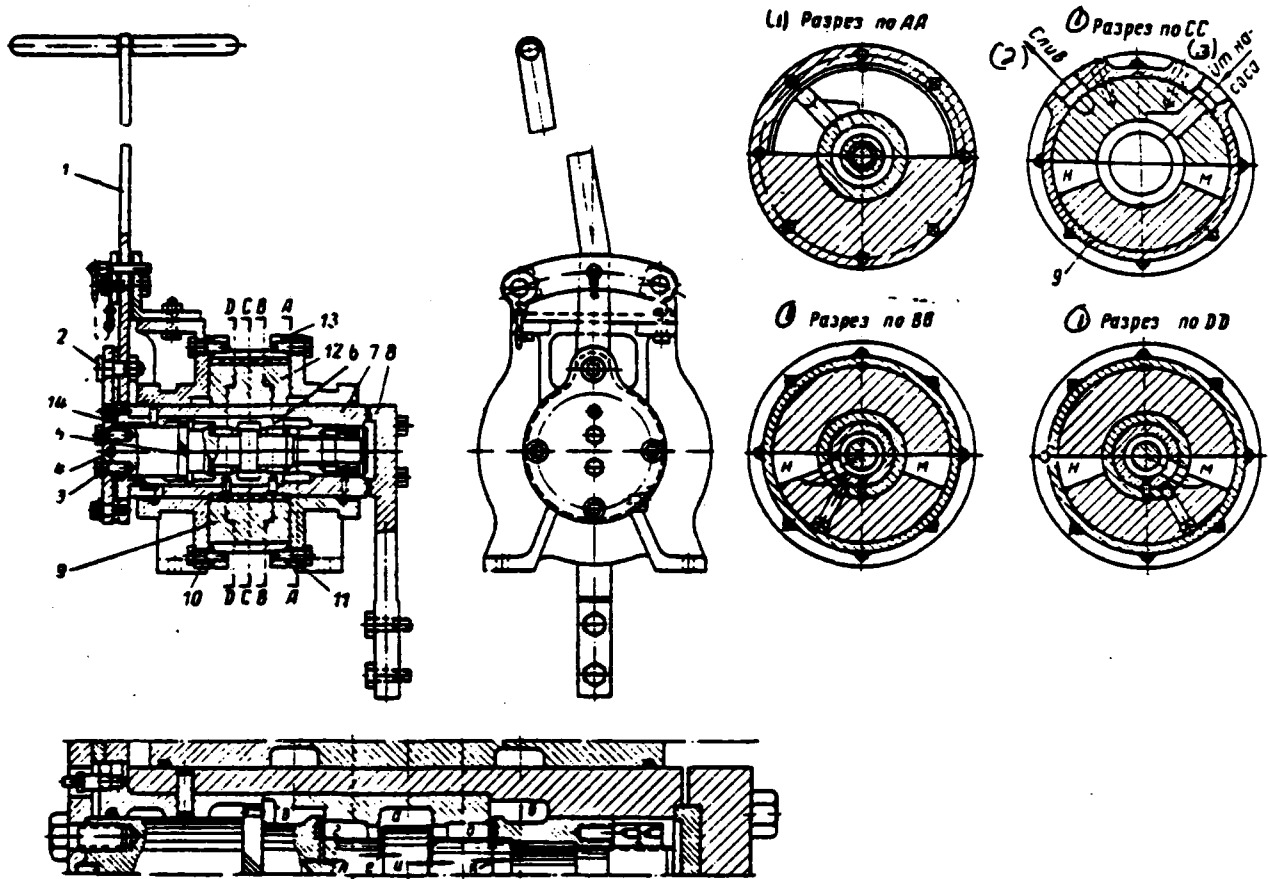

Fig. 397. Rotational hydraulic motor.

Key: (1). Section/cut.

Page 421.

For the powerful/thick hydraulic presses the mechanisms, fed by high-pressure liquid also are applied from the pump-and-battery station. The construction/design of this mechanism is shown in Fig. 398.

Mechanism consists of two cylinders of different diameters 1 and 2 plungers of which are connected to one general/common/total slider 3. Cylinder 1, which has a large diameter, by the control valves of distributor 4, while another cylinder directly coupled with the line from the pump-and-battery station.

The shaft of distributor 4 is connected with the control lever of 5 rods/thrusts through the lever, whose end is hinged connected with slider 3. On the shaft of the controlled distributor lever 6, which is turned during the motion of slider 3, is planted.

During the rotation of control lever of 5 one or another the valve of distributor 4 is opened/disclosed, and slider begins to be moved and to turn lever 6, planted to the shaft of distributor, simultaneously with this through the linkage to turn the shaft of distributor 4, returning its valves to the initial position.

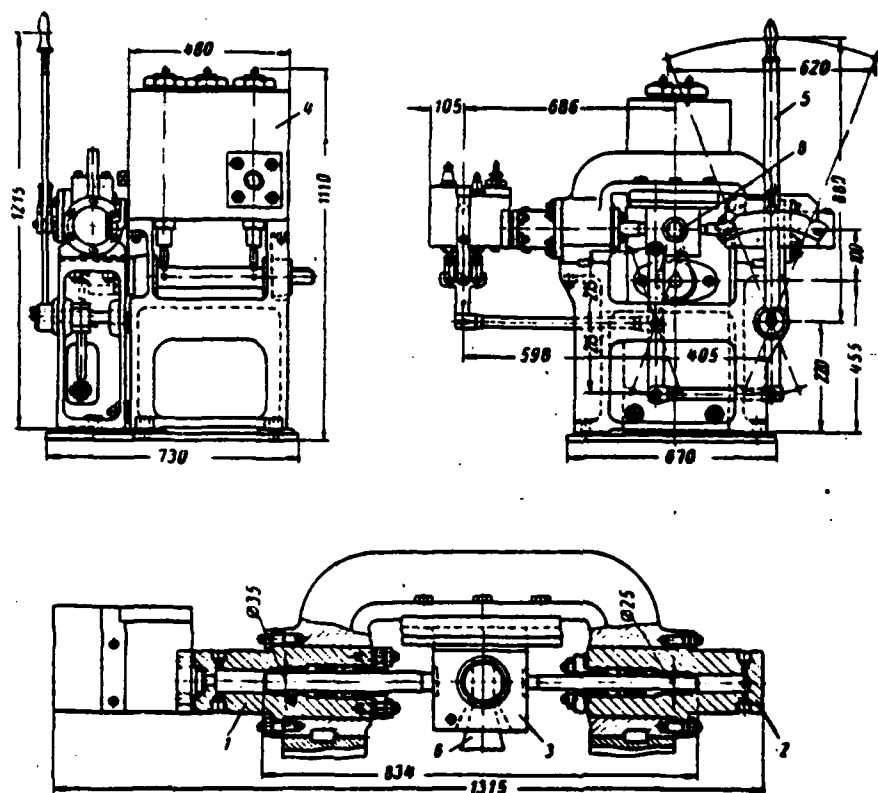

Fig. 398. Hydraulic mechanism of the rotation of the shaft of distributor.

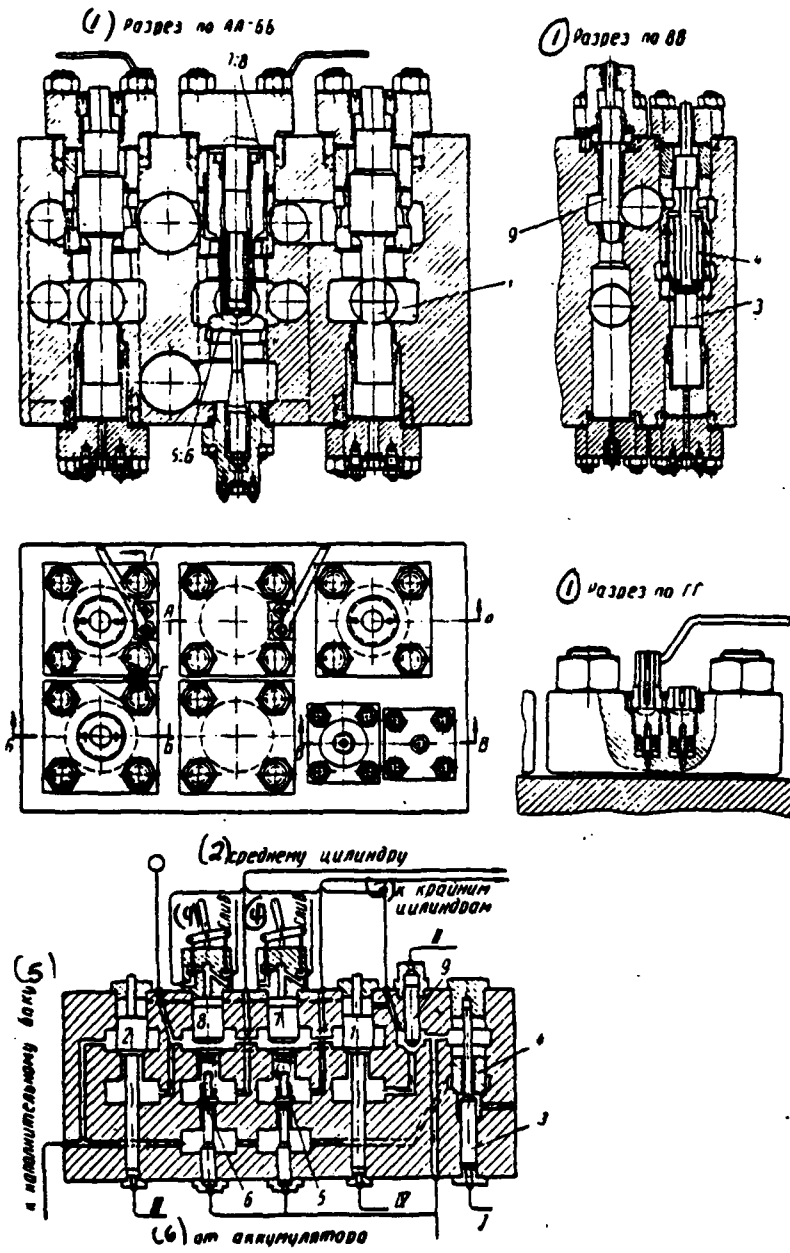

Fig. 399.

Fig. 399. Construction/design and the schematic of the valve distributor of stamping machine by effort/force 10000 m: 1 - pressure valve of working cylinders; 2 - the drain valve of working cylinders; 3 - the pressure valve of pull-backs; 4 - the drain valve of pull-backs; 5 - filler valve of outer working cylinders; 6 - filler valve of pitch working cylinder; 7 - valve of the start of outer working cylinders; 8 - valve of the start of pitch working cylinder; 9 - choke/throttle; I, II, III and IV - line of conduits/manifolds to the the auxiliary distributor.

Key: (1). Section/cut on. (2). to pitch cylinder. (3). to outer cylinder. (4). Drain. (5). to filler Baku.

Page 423.

Thus, the rotation of lever 6 corresponds to the rotation of control lever of press.

The described mechanism successfully is applied in the powerful/thick high-speed presses, in which for valve opening of distributors they are required more than effort/force.

In the distributors with the valves, opened directly by control lever, in the beginning of valve opening and before the complete

coverage its (i.e. usually at the moments of the retarded motion of control lever) clear area of valve is low in comparison with the section/cut of conduit/manifold, and the velocity of the passage of the liquid through the valve approaches in the critical.

The high velocity of liquid and respectively sharp lowering in the pressure in the slot of valve destructively act on the surface of valves and their saddles.

As has already been mentioned above, in the powerful/thick presses the valves, whose lift is accomplished/realized by pressure of liquid on their end/face from below, in the clamp of valve to the saddle - by pressure of liquid on its upper circular surface, are applied.

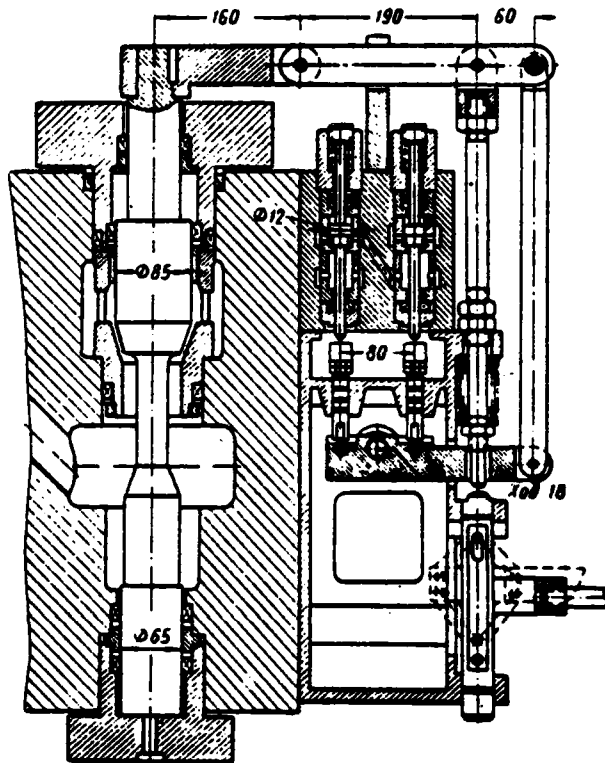

Fig. 400. Construction/design of the controlled choke/throttle.

Page 424.

Construction/design and schematic of distributor with such valves are shown in Fig. 399. Valves are opened/disclosed immediately in the total cross section (complete pass), and throttling/choking liquid, for the purpose of obtaining different velocities of the

motion of cross-beam, is accomplished/realized by a special throttle valve (Fig. 399, pos. 9).

A shortcoming in the design of this distributor is the absence of connection/communication between the throttle valve and the control lever press, which deprives of the possibility to regulate the velocity of the crosshead on its course.

The shortcoming indicated is removed in the construction/design of the controlled choke/throttle, shown in Fig. 400. In this construction/design the choke/throttle is controlled by two-valve distributor. Yoke/arm for valve opening of this distributor is connected with the lever/crank servo system with the choke/throttle and control lever of press.

The lever/crank servo system provides dependent on the control lever of press the displacement of choke/throttle and, thus, with the rotation of control handle is accomplished/realized the control of the velocity of the crosshead.

Pages 425-426.

REFERENCES

1. Сторожев М. В., Гидравлические прессы кузнечно-штамповочного производства, Энциклопедический справочник «Машиностроение», т. 8, Машгиз, 1948.
2. Сторожев М. В., К расчету чисто гидравлических ковочных прессов с аккумулятором, НИИМАШ, Госмашметиздат, 1932.
3. Сторожев М. В., Оптимальное использование гидравлических прессов, «Вестник машиностроения» № 12-13, 1936.
4. Михеев В. А., Гидравлические прессовые установки. Расчет, проектирование и эксплуатация, Машгиз, 1953.
5. Гидравлические прессы (исследование и элементы расчета), ЦНИИТМАШ, книга 54, Машгиз, 1963.
6. Мощные гидравлические прессы для штамповки крупногабаритных деталей. Обзор Б. В. Розанова и Ф. В. Щеглова. «Прикладная механика и машиностроение» № 5, Издательство иностранной литературы, 1963.
7. Розанов Б. В., Мощные гидравлические прессы (обзор иностранной литературы), «Вестник машиностроения» № 2, 1966.
8. Розанов Б. В., Гидравлические прессы специального технологического назначения, Энциклопедический справочник «Машиностроение», т. 8, Машгиз, 1948.
9. Шофман Л. А., Элементы теории холодной штамповки, Оборонгиз, 1962.
10. Мендлин М. А., Штамповка резиной, Оборонгиз, 1944.
11. Истомин П. С., Прессование металлов, Металлургиздат, 1944.
12. Васильев В. Л., Гидравлические установки для прессования цветных металлов, Машгиз, 1951.
13. Жолобов В. В., Прессование профилей в машиностроении. Прогрессивная технология кузнечно-штамповочного производства. Сборник статей под ред. доц. П. В. Камнева, Машгиз, 1963.
14. Жолобов В. В., Богоявленский К. Н., Зубцов М. Г., Ландихов А. Д., Лекаренко Е. М., Постников Н. Н., Обработка цветных металлов и их сплавов давлением, Metallurgizdat, 1965.
15. Агроскин И. И., Дмитриев Г. Т., Ивашов А. И., Пикалов Ф. И., Гидравлика, Госэнергоиздат, 1944.
16. Подвидз Л. Г. и Яньшин Б. И., Гидравлика, Справочник машиностроения, т. 2, гл. XVI.
17. Кривченко Г. И., Гидравлический удар и рациональные режимы регулирования турбин гидроэлектростанций, Госэнергоиздат, 1961.
18. Тимошенко С. П., Сопротивление материалов, ОГИЗ, 1946.
19. Суриц А. А., Гидравлический удар в водопроводах и борьба с ним, Государственное транспортное железнодорожное издательство, 1946.
20. Корифельд М., Упругость и прочность жидкостей, Государственное издательство технико-теоретической литературы, 1961.
21. Зайченко И. З., Гидравлическое оборудование современных металлорежущих станков, Машгиз, 1945.
22. Розанов Б. В., Насосы гидропрессовых установок, Энциклопедический справочник «Машиностроение», т. 8, Машгиз, 1948.
23. Жмудь Д. Е., Винтовые насосы с циклоидальным зацеплением, Машгиз, 1948.

24. Перлин И. Л., К расчету мощности аккумуляторной станции гидропрессовых установок, «Вестник инженеров и техников» № 1, 1950.
25. Унксов Е. П., Методика расчета объема аккумулятора для группы гидравлических прессов, НИИМАШ, Госмашиздат, 1932.
26. Розанов Б. В., Производство в США сварных баллонов и котлов высокого давления, «Вестник машиностроения» № 1, Машгиз, 1946.
27. Ernst Muller, Hydraulische Schmiedepressen und Kraftwasseranlagen, Berlin, 1952.
28. Alwey W. A., Modern A., Heavy Forging Plant Journal of the Iron and Steel Institute, vol. 161, part 2, February, 1949.
29. Stone M. D., Large Hydraulic Forging Presses Transaction of the ASME, July, vol. 70, № 25, 1948.
30. Product Engineering February, vol. 26, № 2, pp. 129—134, 1955.
31. Wheelon O. A., High pressure forming on Verson-wheelon Presses, machinery (L), Dec. 9, vol. 87, № 2247, 1955.

Pages 427-428 No typing.

END

FILMED

5-84

DTIC