

AD-A140 191

EFFECTS OF DOLOS BREAKAGE ON THE STABILITY OF
RUBBLE-MOUND BREASTWATER TRU. (U) COASTAL ENGINEERING
RESEARCH CENTER VICKSBURG MS D G MARKLE ET AL. DEC 83
CERC-TR-83-4

1/1

UNCLASSIFIED

F/G 13/13

NL

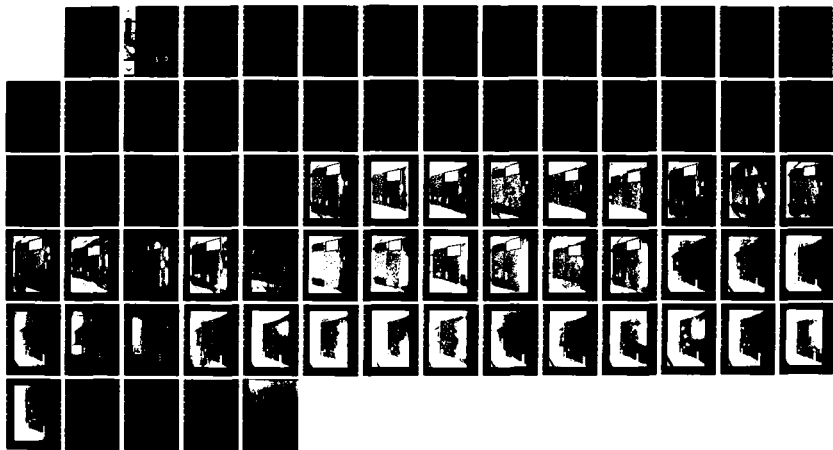

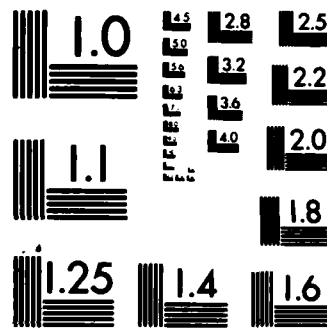

MICROCOPY RESOLUTION TEST CHART
NATIONAL BUREAU OF STANDARDS-1963-A



US Army Corps
of Engineers

ADA140191

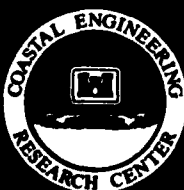

TECHNICAL REPORT CERC-83-4

12

EFFECTS OF DOLOS BREAKAGE ON THE STABILITY OF RUBBLE-MOUND BREAKWATER TRUNKS SUBJECTED TO BREAKING AND NONBREAKING WAVES WITH NO OVERTOPPING

by

Dennis G. Markle, D. Donald Davidson
Coastal Engineering Research Center
U. S. Army Engineer Waterways Experiment Station
P. O. Box 631, Vicksburg, Miss. 39180

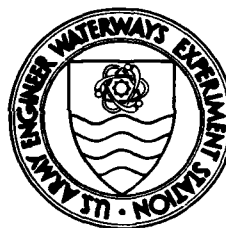

December 1983
Final Report

Approved For Public Release; Distribution Unlimited

DTIC FILE COPY

DTIC
ELECTE
APR 17 1984
S E D

Prepared for Office, Chief of Engineers, U. S. Army
Washington, D. C. 20314

Under Civil Works Work Unit 31563

84 04 17 003

**Destroy this report when no longer needed. Do not
return it to the originator.**

**The findings in this report are not to be construed as an
official Department of the Army position unless so
designated by other authorized documents.**

**The contents of this report are not to be used for
advertising, publication, or promotional purposes.
Citation of trade names does not constitute an
official endorsement or approval of the use of such
commercial products.**

Unclassified

SECURITY CLASSIFICATION OF THIS PAGE (When Data Entered)

REPORT DOCUMENTATION PAGE		READ INSTRUCTIONS BEFORE COMPLETING FORM	
1. REPORT NUMBER Technical Report CERC-83-4	2. GOVT ACCESSION NO. AD-A140191	3. RECIPIENT'S CATALOG NUMBER	
4. TITLE (and Subtitle) EFFECTS OF DOLOS BREAKAGE ON THE STABILITY OF RUBBLE-MOUND BREAKWATER TRUNKS SUBJECTED TO BREAKING AND NONBREAKING WAVES WITH NO OVER- TOPPING	5. TYPE OF REPORT & PERIOD COVERED Final report	6. PERFORMING ORG. REPORT NUMBER	
7. AUTHOR(s) Dennis G. Markle D. Donald Davidson	8. CONTRACT OR GRANT NUMBER(s)		
9. PERFORMING ORGANIZATION NAME AND ADDRESS U. S. Army Engineer Waterways Experiment Station Coastal Engineering Research Center P. O. Box 631, Vicksburg, Miss. 39180	10. PROGRAM ELEMENT, PROJECT, TASK AREA & WORK UNIT NUMBERS Civil Works Work Unit 31563		
11. CONTROLLING OFFICE NAME AND ADDRESS Office, Chief of Engineers U. S. Army Washington, D. C. 20314	12. REPORT DATE December 1983	13. NUMBER OF PAGES 68	
14. MONITORING AGENCY NAME & ADDRESS (if different from Controlling Office)	15. SECURITY CLASS. (of this report) Unclassified	15a. DECLASSIFICATION/DOWNGRADING SCHEDULE	
16. DISTRIBUTION STATEMENT (of this Report) Approved for public release; distribution unlimited.			
17. DISTRIBUTION STATEMENT (of the abstract entered in Block 20, if different from Report)			
18. SUPPLEMENTARY NOTES Available from National Technical Information Service, 5285 Port Royal Road, Springfield, Va. 22161			
19. KEY WORDS (Continue on reverse side if necessary and identify by block number) Breakwaters Dolosse Rubble-mound breakwaters Water waves			
20. ABSTRACT (Continue on reverse side if necessary and identify by block number) ➤ Experimental tests were conducted to determine the quantity and dis- tribution of broken dolosse that will cause a reduction in the stability of the dolos armor layers (1V-on-1.5H sloped, breakwater trunks) when subjected to their no-damage design, breaking or nonbreaking wave conditions with no overtopping. It was concluded that for the range of test conditions consid- ered: (a) if dolos breakage does not exceed 15 percent uniform breakage in the top layer, 15 percent uniform breakage in the bottom layer, 7.5 percent (Continued)			

Unclassified

SECURITY CLASSIFICATION OF THIS PAGE(When Data Entered)

20. ABSTRACT (Continued).

end > uniform breakage in both layers (7.5[%] percent in the top layer plus 7.5[%] percent in the bottom layer), or clusters of 5 broken dolosse, the overall stability of the dolos coverlayers will be very similar to the stability response of a dolos-armored structure with no breakage; and (b) when breakage levels exceed those specified in (a), a structure could either fail catastrophically, have areas of exposed underlayer, and/or have areas with only one layer of dolos armor. The high degree of dolos movement and displacement associated with larger amounts of dolos breakage could cause additional dolos breakage that could ultimately lead to failure of the dolos armor layers.

Unclassified

SECURITY CLASSIFICATION OF THIS PAGE(When Data Entered)

PREFACE

The study reported herein was authorized by the Office, Chief of Engineers (OCE), U. S. Army, under Civil Works Research Work Unit Number 31563, "Effect of Broken Armor Units on Breakwater Stability." Funds were provided through the Coastal Engineering Research Area under the field managership of the Coastal Engineering Research Center and OCE Technical Monitor, Mr. J. Lockhart.

The study was conducted at the U. S. Army Engineer Waterways Experiment Station (WES) during the period July 1978 to August 1982 under the general direction of Messrs. H. B. Simmons and F. A. Herrmann, Jr., Chief and Assistant Chief of the Hydraulics Laboratory, Dr. R. W. Whalin and Mr. C. E. Chatham, former and present Chiefs of the Wave Dynamics Division, and Mr. D. D. Davidson, Chief of the Wave Research Branch. The Wave Dynamics Division and its personnel were transferred to the Coastal Engineering Research Center (CERC) of WES on 1 July 1983 under the direction of Dr. R. W. Whalin, Chief of CERC. The study was conducted by Messrs. W. G. Dubose and C. R. Herrington, Engineering Technicians, under the supervision of Mr. D. G. Markle, Research Hydraulic Engineer. This report was prepared by Messrs. Markle and Davidson.

Commanders and Directors of WES during the conduct of this study and the preparation and publication of this report were COL John L. Cannon, CE, COL Nelson P. Conover, CE, and COL Tilford C. Creel, CE. Technical Director was Mr. F. R. Brown.

Accession For	
NTIS GRA&I	<input checked="" type="checkbox"/>
DTIC TAB	<input type="checkbox"/>
Unannounced	<input type="checkbox"/>
Justification	
By _____	
Distribution/	
Availability Codes	
Dist	Avail and/or Special
A-1	

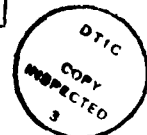

CONTENTS

	<u>Page</u>
PREFACE	1
CONVERSION FACTORS, U. S. CUSTOMARY TO METRIC (SI) UNITS OF MEASUREMENTS	3
PART I: INTRODUCTION	4
Background	4
Purpose of the Model Study	4
PART II: ANALYTICAL CONSIDERATION	5
Stability of Rubble-Mound Breakwaters	5
Cover-Layer Material Characteristics	5
Research Developments	7
PART III: THE MODEL	9
Scale-Effect Considerations	9
Test Facilities and Equipment	9
Flume Calibration	10
Methods of Constructing Test Sections	10
Methods of Determining Damage	11
PART IV: TESTS	13
Test Procedures	13
Selection of Test Conditions	13
Dolos Breakage Conditions Tested	14
PART V: TEST RESULTS	17
Nonbreaking Waves	17
Breaking Waves	20
PART VI: CONCLUSIONS	23
REFERENCES	24
TABLES 1-3	
PHOTOS 1-38	
PLATES 1-2	
APPENDIX A: NOTATION	

CONVERSION FACTORS, U. S. CUSTOMARY TO METRIC (SI)
UNITS OF MEASUREMENT

U. S. customary units of measurement used in this report can be converted to metric (SI) units as follows:

<u>Multiply</u>	<u>By</u>	<u>To Obtain</u>
cubic feet	0.02831685	cubic metres
feet	0.3048	metres
feet per second per second	0.3048	metres per second per second
inches	25.4	millimetres
pounds (force)	4.448222	newtons
pounds (force) per cubic foot	157.087467	newtons per cubic metre
square feet	0.09290304	square metres
tons (force)	8896.444	newtons

EFFECTS OF DOLOS BREAKAGE ON THE STABILITY OF RUBBLE-MOUND
BREAKWATER TRUNKS SUBJECTED TO BREAKING AND
NONBREAKING WAVES WITH NO OVERTOPPING

PART I: INTRODUCTION

Background

1. This experimental investigation was part of the effort conducted under the Corps of Engineers Research and Development Program, Coastal Engineering Field of Endeavor, entitled "Effect of Broken Armor Units on Breakwater Stability," to determine the effects of broken concrete armor units on breakwater stability and to establish criteria by which more definitive decisions can be made as to when maintenance and/or rehabilitation should be initiated. The research consisted of a prototype survey of existing Corps structures (Markle and Davidson, in preparation) protected with concrete armor units and experimental tests of dolos-armored, breakwater trunk sections (1V-on-1.5H slopes) subjected to both breaking and nonbreaking waves with no overtopping. Results of the experimental tests are reported herein.

Purpose of the Model Study

2. No specific criteria exist as to when rehabilitation or repair should be initiated on breakwaters with broken dolosse. The purpose of the experimental tests was to determine the quantity and distributions of broken dolosse that can exist and not cause a reduction in the stability of the dolos armor layers (1V-on-1.5H sloped, breakwater trunks) when subjected to their no-damage design, breaking or nonbreaking wave conditions with no overtopping. Results of these tests provide a reliable data base from which decisions can be made regarding whether or not repair of dolos-armored breakwater trunks should be initiated (as a function of the amount and distribution of broken armor units).

PART II: ANALYTICAL CONSIDERATIONS

Stability of Rubble-Mound Breakwaters

3. The derivation of the dimensionless term

$$\frac{(\gamma_a)^{1/3} H}{(S_a - 1)(W_a)^{1/3}} \quad (1)$$

where

γ_a = specific weight of armor unit, pcf*

H = incident wave height, ft

S_a = specific gravity of the armor unit relative to the water in which it is situated, i.e., $S_a = \gamma_a / \gamma_w$

γ_w = specific weight of water, pcf

W_a = weight of individual armor unit, lb

referred to as the stability number (N_s)** was presented by Hudson (1958) as a measure of the stability of armor units when exposed to wave attack. Based on the analytical considerations and data contained in that report, the following empirical stability equation (Hudson formula) was derived:

$$W_a = \frac{\gamma_a H^3}{K(S_a - 1)^3 \cot \alpha} \quad (2)$$

where

K = no-damage stability coefficient

α = angle the breakwater's sea-side slope makes with the horizontal, deg

Cover-Layer Material Characteristics

4. In order to design a rubble-mound breakwater, information is needed for determining the layer thicknesses and porosities of the various construction materials. These two characteristics are dependent on the shape, weight,

* A table of factors for converting U. S. customary units of measurement to metric (SI) units is presented on page 3.

** For convenience, symbols and unusual abbreviations are listed and defined in the Notation (Appendix A).

specific weight of the individual armor units or underlayer stone, and type of placement (either random, special, or pattern) that is used. The thickness of one or more layers is defined as

$$t = nk_{\Delta} \left(\frac{W_a}{Y_a} \right)^{1/3} \quad (3)$$

where

t = average layer thickness of the armor unit or underlayer material, ft

n = number of layers

k_{Δ} = coefficient that is a function of shape and method of placement of armor unit or underlayer stone

The in-place porosities of the various construction material layers can be determined from

$$P = \left(1 - \frac{NW_a}{Ay_a t} \right) 100 \quad (4)$$

where

P = porosity of material, percent

N = number of units or underlayer stone placed on a given surface area

A = surface area, ft²

The stability response of the primary cover-layer protection is a function of the number of armor units placed over a given area. Once a representative k_{Δ} and P have been experimentally established for a specific wave stability (K) of a given armor unit, the density of armor units (number of units per given area) needed to obtain this stability can be determined by

$$\frac{N}{A} = CV^{-2/3} \quad (5)$$

where

$$C = nk_{\Delta} \left(1 - \frac{P}{100} \right) \quad (6)$$

and

$$v = \left(\frac{W_a}{Y_a} \right)$$

Research Developments

5. Experimental tests of dolos-armored breakwater trunks (Figure 1) subjected to nonbreaking waves with no overtopping (Carver and Davidson 1977) and breaking waves with no overtopping (Carver, in preparation) have been conducted previously at the U. S. Army Engineer Waterways Experiment Station (WES). Both the breaking and nonbreaking wave tests covered a wide range of relative depths (d/L) and wave steepnesses (H/L) and the breaking wave tests also included a large range of relative wave heights (H/d). The nonbreaking wave tests were conducted with a flat bottom seaward of the test section, while the breaking wave tests incorporated a 1V-on-10H bathymetry seaward of the test section toe. Breakwater slopes of 1V on 1.5H, 1V on 2H, and 1V on 3H were constructed using two layers ($n = 2$) of random-placed dolosse. Data from these tests showed that for a density of units per given area equal to $0.83V^{-2/3}$, i.e. $n = 2$, $k_{\Delta} = 0.94$, and $P = 56$ percent:

- a. Nonbreaking wave dolos stability is not significantly affected by relative depth and wave steepness for the conditions tested and a stability coefficient (K) of 31 can be used for dolosse on breakwater trunks subjected to nonbreaking, nonovertopping waves.
- b. Breaking wave dolos stability is dependent upon relative depth, relative wave height, and wave steepness, and depending on the combination of these three parameters, the breaking wave stability coefficient for dolos trunks subjected to breaking waves with no overtopping can vary from 36 down to slightly less than 15.

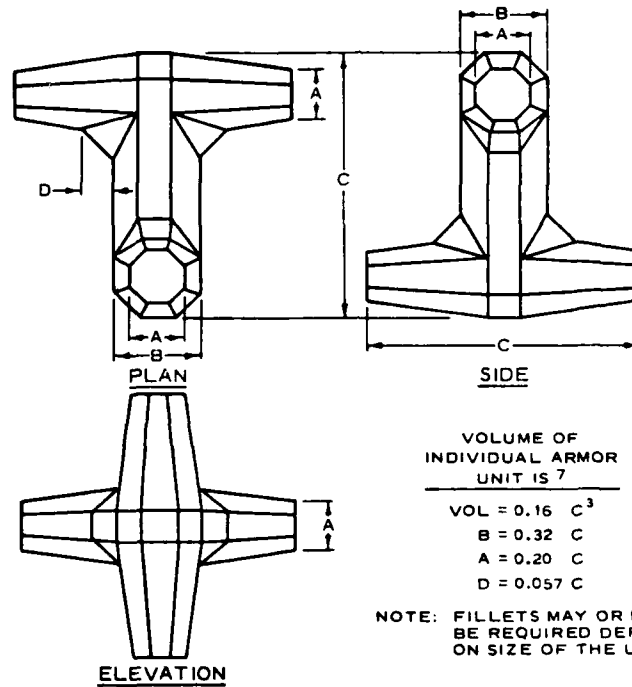

VOLUME OF INDIVIDUAL UNITS, CU FT											
	7.14	14.29	28.57	71.43	142.86	214.29	285.71	357.14	428.57	500.00	571.43
WEIGHT OF INDIVIDUAL ARMOR UNITS, TONS											
UNIT WEIGHT PCF	0.50	1.00	2.00	5.00	10.00	15.00	20.00	25.00	30.00	35.00	40.00
149.5	0.53	1.07	2.14	5.34	10.68	16.02	21.36	26.70	32.04	37.38	42.71
156.0	0.56	1.11	2.23	5.57	11.14	16.71	22.29	27.86	32.43	39.00	44.57
162.0	0.58	1.16	2.31	5.79	11.57	17.36	23.14	28.93	34.71	40.50	46.29
NUMBER OF RANDOMLY PLACED UNITS (N) PER 1000 SQ FT											
	223.0	140.5	88.5	48.1	30.3	23.1	19.1	16.4	14.6	13.1	12.0
THICKNESS OF TWO LAYERS (21) RANDOM PLACED, FT											
	3.8	4.6	5.7	7.8	9.8	11.2	12.4	13.3	14.2	14.9	15.6
DIMENSIONS OF ARMOR UNITS, FT											
SYMBOL	0.71	0.89	1.13	1.53	1.93	2.20	2.43	2.61	2.78	2.92	3.06
A	1.13	1.43	1.80	2.44	3.08	3.52	3.88	4.18	4.44	4.68	4.89
B	3.55	4.47	5.63	7.64	9.63	11.02	12.13	13.08	13.89	14.62	15.29
C	0.20	0.25	0.32	0.43	0.55	0.62	0.69	0.74	0.79	0.83	0.87
D											

NOTE: SHAPE AND DIMENSIONS OF UNIT WERE BASED ON THOSE USED IN MODEL TESTS. AT PRESENT TIME, INVENTOR RECOMMENDS B = 0.32C TO 0.36C, DEPENDING ON THE WEIGHT OF AN INDIVIDUAL UNIT.

Figure 1. Dolos specifications

PART III: THE MODEL

Scale-Effect Considerations

6. If the absolute sizes of experimental breakwater materials and/or experimental wave dimensions become too small, the flow regime around the breakwater armor approaches laminar and the induced drag forces on the armor units become highly dependent on Reynolds number (R_N). Under these conditions, full-scale stability is not accurately reproduced in the experiment and this condition is referred to as stability scale effects. Through the use of available data on full-scale and large- and small-scale breakwater structures, Hudson (1975) established a criterion by which experimental breakwater scale effects can be precluded, i.e. scale effects will be negligible if the Reynolds's stability number

$$R_N = \frac{g^{1/2} H^{1/2} \ell_a}{\nu} \quad (7)$$

where

g = acceleration due to gravity, ft/sec²

H = wave height, ft

ℓ_a = characteristic length of armor unit, ft

ν = kinematic viscosity of experimental fluid medium, ft²/sec

is equal to or greater than 3×10^4 . For all experimental tests reported herein, the armor and wave conditions were selected such that R_N was greater than 3×10^4 .

Test Facilities and Equipment

7. The nonbreaking wave tests were conducted in flat bottom concrete wave flumes, 5 and 6.75 ft wide, 4 ft deep, and 119 ft long. The test flumes shared a common vertical displacement generator that was located approximately 90 ft from the toe of the breakwater test sections.

8. The breaking wave tests were conducted in a 5-ft-wide, 4-ft-deep, and 119-ft-long concrete flume. The toe of the breakwater test section was located approximately 90 ft from a vertical displacement wave generator. The first 10 ft of flume bottom, immediately seaward of the test section, was

molded on a 1V-on-10H slope while the remaining 80 ft was flat.

Flume Calibration

9. Prior to installation of the experimental test sections, wave rods were installed in the test flumes at the points where the breakwaters' sea-side toes would be positioned and the flumes were calibrated for the wave heights, wave periods, and water depths selected for the test series. This is the most accurate method of calibrating to ensure that the defined test wave heights are not contaminated with reflected waves from the breakwater slope. This is analogous to full scale where the design conditions are determined by hindcasts or measurements prior to construction of the breakwater. Test waves (monochromatic) having the required periods and heights were produced in the experiment by varying the frequency and amplitude of the wave generator's plunger motion.

Methods of Constructing Test Sections

10. All experimental breakwater test sections were constructed to reproduce as closely as possible results of usual methods of constructing full-scale breakwaters. The core material was dumped by bucket or shovel into the flume and compacted with hand trowels to simulate natural consolidation that would occur as a result of wave action during a prototype construction season. Once the core material was compacted and smoothed to grade, the underlayer stone was added by shovel and smoothed to grade by hand or with trowels. No excessive pressure was applied to the underlayer during its placement and grading. The dolos armor and secondary armor stone were placed in a random manner corresponding to work performed by a general coastal contractor, i.e., they were individually placed but laid down without special orientation or fitting. After each completed test, the dolos armor units were removed and the underlayer stone and secondary armor (where applicable) were returned to original grade and the dolos cover layers were reconstructed in preparation for the next test. The sections used for the nonbreaking and breaking wave tests are shown in Plates 1 and 2, respectively. Dolos armor units with individual weights of 0.276 lb and a specific weight of 142.2 pcf were used on all the test sections. The remainder of the experimental construction material was comprised of various sizes of limestone rock with a specific weight of 165 pcf.

Methods of Determining Damage

11. In order to evaluate and compare breakwater stability test results, it is necessary to quantify the changes that have occurred on a given structure due to the attack of waves of specified characteristics. During the early 1950's, WES developed a method of measuring the percent damage incurred by a test section that is still used today. This damage-measurement technique requires that the cross-sectional area occupied by armor units be determined for each stability test section. Armor unit area is computed from elevations (soundings) taken at closely spaced grid point locations over the seaward face of the structure before the armor is placed on the underlayer, after the armor has been placed but before the section has been subjected to wave attack, and finally after wave attack. Elevations are obtained with a sounding rod equipped with a circular spirit level for plumbing, a scale graduated in thousandths of a foot, and a ball-and-socket foot for adjustment to the irregular surface of the breakwater slope. The diameter (diam) in inches of the circular foot of the sounding rod was related to the size of the material being sounded by the following equation:

$$\text{diam} = 13.7 \left(\frac{W_a}{Y_a} \right)^{1/3} \quad (8)$$

A series of sounding tests, in which both the weight of the dolosse and the diameter of the sounding foot were varied, indicated that the above relation would give a measured thickness which visually appeared to represent an acceptable two-layer thickness.

12. Sounding data for each test section were obtained as follows: after the underlayer was in place, soundings were taken on the sea-side slope of the structure along rows beginning at and parallel to the longitudinal center line of the structure and extending seaward in 0.25-ft horizontal increments. The entire sea-side slope of the breaking wave test sections was sounded, while the nonbreaking wave test section soundings stopped at the interface of the dolosse and secondary armor. Soundings were taken at 0.25-ft intervals along each parallel row, except for the outer 1 ft on each end of the parallel rows. The 1 ft of structure next to each wall was not considered because of the possibility of discontinuity effects between the armor units

and the flume walls. Soundings were taken at the same points once the armor was in place and again after the structure had been subjected to wave attack.

13. Sounding data from each stability test were reduced in the following manner. The individual sounding points obtained on each parallel row were averaged to yield an average elevation at the bottom of the armor layer before the armor stone was placed and then at the top of the armor layer before and after testing. From these values, the cross-sectional armor area before testing and the area from which armor units were displaced (either downslope or off the section) were calculated. Damage was then determined from the following relation:

$$\text{Percent damage} = \frac{A_2}{A_1} (100) \quad (9)$$

where

A_1 = area before testing, ft^2

A_2 = area from which armor units have been displaced, ft^2

The percentage given by this sounding technique is therefore a measurement of an end area which converts to a average volume of armor material that has been moved from its original location.

14. Along with percent damage measurements taken after testing, visual observations of activity occurring during a test and the condition of the test section at the end of the test were recorded by the operator. The following list of adjectives, in order of increasing severity, is used for recording experimental observations of armor unit activity and reporting test results for damage on each test section: (a) slight, (b) minor, (c) moderate, (d) significant, (e) major, and (f) extensive. Slight and minor are used to describe acceptable activities or results, moderate describes borderline acceptability, while significant to extensive describe unacceptable conditions of increasing severity. Use of these adjectives along with the percent damage measurements allows some quantification of the severity and/or amount of rocking in place, onslope displacement, offslope displacement, and resulting damage accrued by the breakwater armor layers and made it possible to analyze and compare the stability test results reported herein.

PART IV: TESTS

Test Procedures

15. Each of the test sections was constructed in the test flume, before-test photographs and soundings were taken, the flume was flooded to the appropriate water depth, and the test section was subjected to the selected shakedown and test wave conditions. Test time was accumulated in 30-sec cycles (i.e., the wave generator was started, run for 30 sec, and then stopped). After each cycle, sufficient time was provided for the test flume to still out before the next cycle was run. This procedure eliminated contamination of generated waves by rereflected waves from the wave generator. During stilling time between cycles, detailed observations of the structure's response to the previous cycle of test waves were recorded by the operator. These observations included movement occurring on the structure and a general statement of the structure's condition at that point in the test. Five to six shakedown wave cycles were run on newly constructed armor layers. The shakedown wave heights were equal to about one-half of the test wave heights and were used to simulate smaller amplitude waves that would normally occur during prototype construction. These waves provide some measure of consolidation and seating of the armor units prior to their exposure to the design, or test, wave conditions. Following the shakedown, the section was exposed to a sufficient duration of test wave cycles to assure that either all damage had abated or the amount of damage had exceeded an acceptable limit. At the conclusion of the test, the flume was drained, after-test soundings and photographs were taken, and the condition of the test section was summarized in the test notes. Each test section was rebuilt and the test was repeated. The purpose of the repeat test was to check consistency of results and assure that small variations in experimental construction were not critical to the stability of the structure. For the majority of the combined breakage and test conditions reported on herein, the original and repeat test results were very similar. Where minor differences in test results did occur, the test showing the higher degree of damage was selected for reporting.

Selection of Test Conditions

Nonbreaking wave tests

16. An experimental armor unit size and nonbreaking wave height were

selected that would produce a stability coefficient (K) of approximately 31 for two layers of random-placed dolosse on a 1V-on-1.5H slope. A range of wave periods were selected to cover a wide range of nonbreaking wave steepnesses (H/L) and relative depths (d/L). All tests were conducted with an experimental water depth of 2 ft. This ensured that the effects of bottom friction would be negligible and thus would not produce breaking wave conditions. The wave heights, wave periods, and water depth used were identical with a portion of those used by Carver and Davidson (1977). Table 1 presents a summary of the nonovertopping test conditions used for both the nonbreaking and breaking wave tests.

Breaking wave tests

17. Due to time and funding constraints imposed on this study and the wide range of breaking wave stability coefficients reported by Carver (in preparation) for dolosse, only the worst set of breaking wave test conditions was selected for this test series. The test condition selected (1.62-sec, 0.45-ft breaking waves with no overtopping in a water depth of 0.50 ft, Table 1) was one of the three conditions reported by Carver as producing the lowest dolos stability coefficient ($K \cong 15$). For this reason, it was felt that this test condition would produce the severest wave form relative to dolos stability on 1V-on-1.5H slopes. Thus dolos breakage conditions on 1V-on-1.5H slopes acceptable for this wave condition would most likely be acceptable for less severe breaking wave conditions.

18. Both the breaking and nonbreaking wave conditions were nonovertopping. By this it is meant that some minor splash of water could pass over the crown of the breakwater, but the crown height was constructed to an elevation that did not allow any solid water overtopping. The crown elevation needed to prevent overtopping was dependent upon the runup produced and the runup varied with the incident wave conditions. It was found that a crown elevation equal to approximately one wave height above the still-water level (swl) was sufficient to prevent solid water overtopping on both the breaking and nonbreaking wave test sections.

Dolos Breakage Conditions Tested

19. The following dolos breakage conditions were tested for both breaking and nonbreaking waves with no overtopping (Tables 2 and 3):

- a. Various percentages of the top layer of dolosse broken and uniformly distributed throughout the top layer (all uniform breakage conditions extended from the center line of the crown to the seaward extent of dolos coverage).
- b. Various percentages of the bottom layer of dolosse broken and uniformly distributed throughout the bottom layer.
- c. Various percentages of both layers of dolosse broken and uniformly distributed through both layers.
- d. Various size clusters of broken dolosse located above, at, and below the swl. Cluster breakage means all the dolosse in a given cluster are broken and the breakage extends through both layers of dolosse.

20. On the uniform breakage in the top layer test sections, the entire test section was initially built with whole dolosse. Once construction was completed, whole units were removed from the top layer and replaced with broken dolosse. Each broken dolos consisted of two pieces which when joined together would equal the size and weight of the whole dolos that it was replacing. The broken dolos pieces were placed with the same orientation as the whole dolosse had prior to their removal. During removal of whole dolosse and placement of broken dolosse, care was taken not to disturb surrounding armor units. The removal of whole dolosse and replacement with dolos pieces were carried out uniformly over the sea-side dolos armor and were continued until a predetermined percentage of the top layer of dolosse had been replaced with broken dolosse.

21. Placement of breakage in the bottom layer could not be carried out in the same manner as uniform breakage in the top layer, as this would have required the removal and replacement of several top layer dolosse which could have either increased or decreased the overall dolos stability relative to an undisturbed test section. For this reason, the number of broken dolosse to be placed in the bottom layer was established prior to construction, and the breakage was uniformly built into the bottom layer during the initial construction of the dolos armor layers. Care was taken to place the broken dolosse in a similar manner that whole dolosse would have been placed in the bottom layer.

22. Test sections with uniform dolos breakage in both layers were constructed using the techniques described in paragraphs 20 and 21 for placement of breakage in the top and bottom layers, respectively. For all of the uniform breakage tests, the number of broken dolosse placed was based on a

percentage of the number of dolosse in the top and/or bottom layer. Previous experience has shown that for a two-layer system of randomly placed dolosse, 55 percent of the total number of dolosse comprise the bottom layer and the remaining 45 percent make up the top layer. On all tests where the calculated number of broken dolosse needed to make up a certain percentage of either the top or bottom layer did not come out to be a whole number, the number was rounded up to the next whole number.

23. The cluster breakage test sections were initially constructed using whole dolosse. Once the construction was completed, a specified number of whole dolosse were removed and replaced with an equal number of broken dolosse. Care was taken to place the broken dolosse with the same configuration (as closely as possible) as the whole dolosse were in prior to their removal. In some cases, additional whole dolosse had to be removed from the top layer in order to place the required number of broken units in the bottom layer of the cluster. Where this was done, the whole dolosse were replaced with the same orientation as they had before being disturbed.

PART V: TEST RESULTS

Nonbreaking Waves

Uniform breakage in top layer

24. Tests were conducted with 15, 25, and 35 percent breakage in the top layer of dolosse using all three nonbreaking wave test conditions (Table 1). All three wave conditions produced minor to moderate damage on the 15 percent breakage test sections and moderate to significant damage on the 35 percent breakage test sections. The 25 percent breakage test sections accrued moderate damage when exposed to the 1.31- and 2.65-sec wave conditions and significant damage when exposed to the 1.89-sec test conditions. Armor unit movement consisted of in-place reorientation and downslope displacement of both whole dolosse and dolos pieces. No instances were observed (for the entire test series reported) where either whole dolosse or dolos pieces were displaced upslope and remained in this position. Some units would displace slightly upslope during the wave runup, but they would either fall back into their original position or be displaced downslope during the wave rundown. The test sections that sustained acceptable damage levels had only minor to moderate amounts of reorientation and rocking in place of whole and broken dolosse. Those sections that accrued unacceptable degrees of damage had moderate to significant amounts of in-place rocking and reorientation of armor units. Photos 1-3 show typical before-test conditions of 15, 25, and 35 percent breakage test sections, respectively. The dark units are the broken dolosse. Photos 4-6 show typical after-test acceptable damage level on the 15 percent breakage section and typical unacceptable damages accrued by the 25 and 35 percent breakage test sections, respectively. Results of tests are also shown in Table 2.

Uniform breakage in bottom layer

25. The 15 and 25 percent uniform breakage test sections were exposed to all of the nonbreaking wave test conditions. The 1.31- and 2.65-sec test waves produced acceptable degrees of damage on both the 15 and 25 percent breakage test sections (minor to moderate damage). The 1.89-sec nonbreaking waves produced acceptable damage (minor to moderate) on the 15 percent breakage sections and unacceptable damage (major) on the 25 percent breakage sections. Photos 7 and 8 show typical before-test conditions of 15 and

25 percent breakage test sections, respectively. A typical view of the acceptable damage accrued on the 15 percent breakage test section is shown in Photo 9. Photo 10 shows one example of the major damage accrued by the 25 percent breakage test section when exposed to the 1.89-sec nonbreaking waves. As well as the displacement evident in the after-test photographs, the test sections with acceptable levels of damage had minor amounts of in-place rocking and reorientation of whole dolosse, while those test sections which sustained unacceptable degrees of displacement also exhibited in-place rocking and reorientation of armor units that ranged from moderate to major (Table 2).

Uniform breakage in both layers

26. During testing of the uniform breakage in the top and bottom dolos layers, it was noted that the 1.89-sec wave conditions appeared to cause higher levels of damage and the 1.31- and 2.65-sec wave conditions produced very similar lower damage levels on identical test sections. For this reason, the initial tests conducted to define the acceptable combined breakage percentage for both layers of dolosse used only the 1.89-sec wave condition. Once this percentage was found, check tests were conducted using the 2.65-sec wave condition to give assurance that the dolos breakage percentage would also be acceptable for other nonbreaking wave conditions.

27. Combined dolos breakages of 15.0 percent in the top layer and 15.0 percent in the bottom layer, 10.0 percent in the top layer and 10 percent in the bottom layer, and 7.5 percent in the top layer and 7.5 percent in the bottom layer were subjected to the 1.89-sec nonbreaking wave conditions. The 15.0 and 10.0 percent breakage test sections sustained unacceptable damage that ranged from moderate to major. Downslope displacement of both whole and broken dolosse resulted in significant exposure of the underlayer stone. Along with the armor displacement, the sections also showed high degrees (moderate to major) of in-place rocking and reorientation of both whole and broken dolosse. The 7.5 percent breakage test sections accrued damage that ranged from slight to minor when exposed to the 1.89- and 2.65-sec nonbreaking waves. Some downslope displacement of both whole and broken dolosse occurred, but it was very slight compared with the displacement observed on the two higher percent breakage conditions. The 7.5 percent breakage test sections showed slight to very minor amounts of rocking in place and reorientation of whole and broken dolosse and no exposure of underlayer stone. Photos 11-13 show typical before-test conditions of the 7.5, 10.0, and 15.0 percent combined

breakage test sections, respectively. Photo 14 shows an after-test view of a 7.5 percent breakage test section. Photos 15 and 16 show typical after-test examples of the major damage sustained by the 10.0 and 15.0 percent breakage test sections (Table 2).

Cluster breakage

28. The cluster breakage tests consist of 10 and 5 broken units in a cluster with individual clusters located above, at, and below the swl. The 10-unit cluster test sections sustained significant to extensive damage when exposed to the 1.89-sec nonbreaking wave conditions. This damage included unraveling and displacement of the clusters of broken units as well as unkeying and displacement of large numbers of whole units surrounding the broken unit clusters, which exposed large areas of underlayer stone. Along with the large numbers of displaced units, significant levels of rocking in place and reorientation of both whole and broken units were observed. The 5-unit cluster test sections sustained only minor to moderate damage when exposed to either 1.89- or 2.65-sec nonbreaking waves. Slight to minor amounts of rocking in place and reorientation of both whole and broken dolosse were observed on the 5-unit cluster test sections. Before-test conditions of 5- and 10-unit cluster test sections are shown in Photos 17 and 18, respectively. Photos 19 and 20 show examples of the after-test conditions of the 5- and 10-unit cluster test sections, respectively.

29. Table 2 lists all the nonbreaking wave tests that were conducted and includes both original and repeat tests of the various dolos breakage conditions. The percent damages calculated using the WES damage measurement method described in paragraphs 11-13 are included in Table 2. The general criterion is that 0 to 5 percent is acceptable and above 5 percent is unacceptable damage. In some instances, however, the damage measurements were less than 5 percent, but based on visual observations the structures were ruled unacceptable. In many instances the structures were ruled unacceptable due to the high degrees of in-place rocking and reorientation of armor units. Even though these structures did not sustain large degrees of damage, they showed a high potential to accrue significant damage. In some cases, structures were ruled acceptable when the measured percent damage slightly exceeded 5 percent. This judgment was based on visual observations made throughout the conduct of the test that the structure had not shown a high degree of movement and that the larger percent damage calculated was most likely due to

the nesting in and consolidation of the broken armor unit pieces into the voids between whole dolos units.

Breaking Waves

Uniform breakage in top layer

30. Test sections with 25, 20, and 15 percent uniform breakage in the top layer (Photos 21-23, respectively, dark units are broken dolosse) were exposed to the 1.62-sec breaking wave conditions previously described in paragraph 17. Downslope displacement of whole dolosse and dolos pieces resulted in minor, moderate, and significant damage on the 15, 20, and 25 percent uniform breakage tests sections, respectively. The majority of the armor unit displacement occurred over an area that extended from just above the swl down to the sea-side toe. This was the area that received the majority of the impact of the breaking waves and the effects of rundown. The breaking waves did not produce a high runup, and the only water that overtopped the structure was in the form of "splashover" (no solid water passed over the crown). Armor unit displacement on the 25 percent breakage sections resulted in significant exposure of underlayer stone and several areas with one layer of dolos armor protection. The 20 and 25 percent breakage test sections showed minor to moderate and moderate to significant amounts, respectively, of in-place rocking and reorientation of whole and broken dolosse. The armor unit displacement caused moderate amounts of underlayer exposure on the 20 percent breakage sections. The 15 percent breakage test sections exhibited slight to minor amounts of in-place rocking and reorientation of whole dolosse and dolos pieces, but did not have any underlayer stone exposure. The degrees of damage (Table 3) sustained by the 15, 20, and 25 percent test sections were felt to be acceptable (Photo 24), marginal (Photo 25), and unacceptable (Photo 26), respectively.

Uniform breakage in bottom layer

31. The 20 and 15 percent bottom layer breakage test sections (Photos 27 and 28) were exposed to the 1.62-sec breaking wave conditions. Both breakage conditions accrued minor amounts of offslope displacement of whole armor units. The 20 percent breakage test sections had significant amounts of in-place rocking, onslope reorientation, and onslope displacement of whole dolos units. These activities resulted in both spot underlayer exposures and

small areas with one layer of dolos armor. The 15 percent breakage test sections exhibited minor to moderate amounts of in-place rocking and onslope reorientation of armor units, but this did not result in any underlayer stone exposures or areas with only one layer of dolos armor. Photos 29 and 30 are examples of the acceptable and unacceptable after-test damage levels accrued by the 15 and 20 percent breakage sections, respectively (Table 3).

Uniform breakage in both layers

32. Combined dolos breakages of 12.5 percent in the top layer and 12.5 percent in the bottom layer (Photo 31) and 7.5 percent in the top layer and 7.5 percent in the bottom layer (Photo 32) were exposed to the 1.62-sec breaking wave conditions. The 12.5 percent breakage sections showed moderate to significant dolos activity, including in-place rocking and reorientation and onslope displacement of both whole and broken dolosse. This activity was not confined to the top layer of dolosse. In some areas, displacement of top layer dolosse allowed some of the bottom layer dolosse to move, resulting in spot exposures of underlayer stone. The 12.5 percent breakage test sections also accrued enough dolos displacement to have obvious areas with only one layer of dolos protection. The 7.5 percent breakage test sections exhibited moderate amounts of in-place rocking and reorientation and minor to moderate onslope displacement of both whole and broken dolosse. The dolos activity was mainly in the top layer of units. By the end of the tests, the sections had accrued minor to moderate damage, but there were no underlayer stone exposures or areas with only one layer of dolos protection. After-test Photos 33 and 34 show the acceptable and unacceptable damage levels sustained by 7.5 and 12.5 percent breakage sections, respectively (Table 3).

Cluster breakage

33. The 10-unit cluster test sections (Photo 35) accrued moderate to significant damage during exposure to the breaking wave test conditions. The cluster located at the swl showed significant damage to both the cluster and surrounding whole dolosse. A large area on the upper side of this cluster had exposed underlayer, but this was covered when whole dolosse were displaced into the cluster. The remainder of the structure showed minor to moderate amounts of displacement, rocking in place, and reorientation of both whole and broken dolosse. The 5-unit cluster test sections (Photo 36) sustained minor to moderate damage when exposed to the 1.62-sec breaking wave conditions. The damage included minor amounts of both whole and broken armor unit displacement

and moderate degrees of in-place rocking and reorientation of whole and broken dolosse. The majority of armor unit activity occurred in or around the clusters and was distributed evenly over the three different clusters. Photos 37 and 38 show the acceptable and unacceptable after-test conditions of the 5- and 10-unit cluster test sections, respectively (Table 3).

PART VI: CONCLUSIONS

34. Based on the tests and results reported herein, it is concluded that for two layers of random-placed dolosse on 1V-on-1.5H breakwater trunks subjected to their no-damage, design wave heights (breaking or nonbreaking) with no overtopping:

- a. If the dolos breakage does not exceed 15 percent uniform breakage in the top layer, 15 percent uniform breakage in the bottom layer, 7.5 percent uniform breakage in both layers (7.5 percent in top layer plus 7.5 percent in the bottom layer), or clusters of 5 broken dolosse, the overall stability of the dolos cover layers will be very similar to the stability response of a dolos-armored structure with no breakage.
- b. When breakage levels exceed those specified above, a structure could either fail catastrophically, have areas of exposed under-layer stone, and/or have areas with only one layer of dolos armor. Further, larger amounts of dolos breakage can cause high degrees of dolos movement and displacement which could cause structural failure of individual units and ultimately lead to complete failure of the dolos protection.

REFERENCES

Carver, R. D., and Davidson, D. D. 1977 (Nov). "Dolos Armor Units Used on Rubble-Mound Breakwater Trunks Subjected to Nonbreaking Waves with No Overtopping," Technical Report H-77-19, U. S. Army Engineer Waterways Experiment Station, CE, Vicksburg, Miss.

Carver, R. D. "Stability of Stone- and Dolos-Armored, Rubble-Mound Breakwater Trunks Subjected to Breaking Waves with No Overtopping" (in preparation), U. S. Army Engineer Waterways Experiment Station, CE, Vicksburg, Miss.

Hudson, R. Y. 1975 (Jun). "Reliability of Rubble-Mound Breakwater Stability Models," Miscellaneous Paper H-75-5. U. S. Army Engineer Waterways Experiment Station, CE, Vicksburg, Miss.

_____. 1958 (Jul). "Design of Quarystone Cover Layers for Rubble-Mound Breakwaters," Research Report No. 2-2, U. S. Army Engineer Waterways Experiment Station, CE, Vicksburg, Miss.

Markle, D. G., and Davidson, D. D. 1983. "Breakage of Concrete Armor Units; Survey of Existing Corps Structures" (in preparation), U. S. Army Engineer Waterways Experiment Station, CE, Vicksburg, Miss.

Table 1

Nonovertopping Test Conditions for Stability Tests of Randomly Placed
Dolos Armor Units Containing Various Amounts and Distributions

of Armor Unit Breakage: $W_a = 0.276$ lb; $\gamma_a = 142.2$ pcf;

$k_{\Delta} = 0.94$; $P = 56$ percent; $W_1 = W_a/5$; $\text{Cot } \alpha = 1.5$

<u>Test*</u> <u>Conditions</u>	<u>d, ft</u>	<u>d/L</u>	<u>H/L</u>	<u>T, sec</u>	<u>$H_{D=0}$, ft</u>	<u>N_s</u>
<u>Nonbreaking Waves</u>						
A	2.0	0.10	0.031	2.65	0.57	3.57
B	2.0	0.15	0.044	1.89	0.57	3.57
C	2.0	0.25	0.075	1.31	0.57	3.57
<u>Breaking Waves</u>						
D	0.5	0.08	0.072	1.62	0.45	2.82

* Due to time and funding constraints, the test series was limited to the test conditions listed above.

Table 2
Percent Damage Measurements for Nonbreaking Wave Tests

<u>Test Conditions*</u>	<u>Breaking Condition</u>	<u>Percent Damage</u>	
		<u>First Test</u>	<u>Second Test</u>
<u>Uniform Breakage Top Layer</u>			
A	15.0**	2.6	1.3
B	15.0**	1.9	1.5
C	15.0**	4.5	3.0
A	25.0**	0.4	1.9
B	25.0**	4.7	5.5
C	25.0**	1.3	2.4
A	35.0**	1.1	4.6
B	35.0**	7.3	8.9
C	35.0**	2.6	6.3
<u>Uniform Breakage Bottom Layer</u>			
A	15.0**	1.2	3.4
B	15.0**	6.8	6.3
C	15.0**	1.8	4.6
A	25.0**	†	†
B	25.0**	>10.0††	>10.0††
<u>Uniform Breakage Both Layers</u>			
B	7.5**	1.3	3.1
C	7.5**	2.4	2.4
B	10.0**	9.2	4.8
B	15.0**	9.4	6.5
<u>Cluster Breakage</u>			
B	5.0‡	2.3	3.0
C	5.0‡	0.5	0.3
B	10.0‡	12.0	7.8

-
- * Refer to Table 1.
 - ** Percentage of broken dolosse per specified layer(s).
 - † Percent damage measurement not taken.
 - †† Estimated.
 - ‡ Number of broken dolosse in a cluster.

Table 3
Percent Damage Measurements for Breaking Wave Tests

<u>Test Condition*</u>	<u>Breakage Condition</u>	<u>Percent Damage</u>	
		<u>First Test</u>	<u>Second Test</u>
<u>Uniform Breakage Top Layer</u>			
D	15.0**	1.2	7.7
D	20.0**	6.9	3.3
D	25.0**	4.6	8.9
<u>Uniform Breakage Bottom Layer</u>			
D	15.0**	6.7	3.0
D	20.0**	4.6	6.8
<u>Uniform Breakage Both Layers</u>			
D	7.5**	4.2	8.3
D	12.5**	9.3	4.0
<u>Cluster Breakage</u>			
D	5.0†	4.9	4.9
D	10.0†	6.0	6.7

* Refer to Table 1.

** Percentage of broken dolosse per specified layer(s).

† Number of broken dolosse in a cluster.



Photo 1. Before testing, 15 percent uniform breakage in top layer, nonbreaking waves

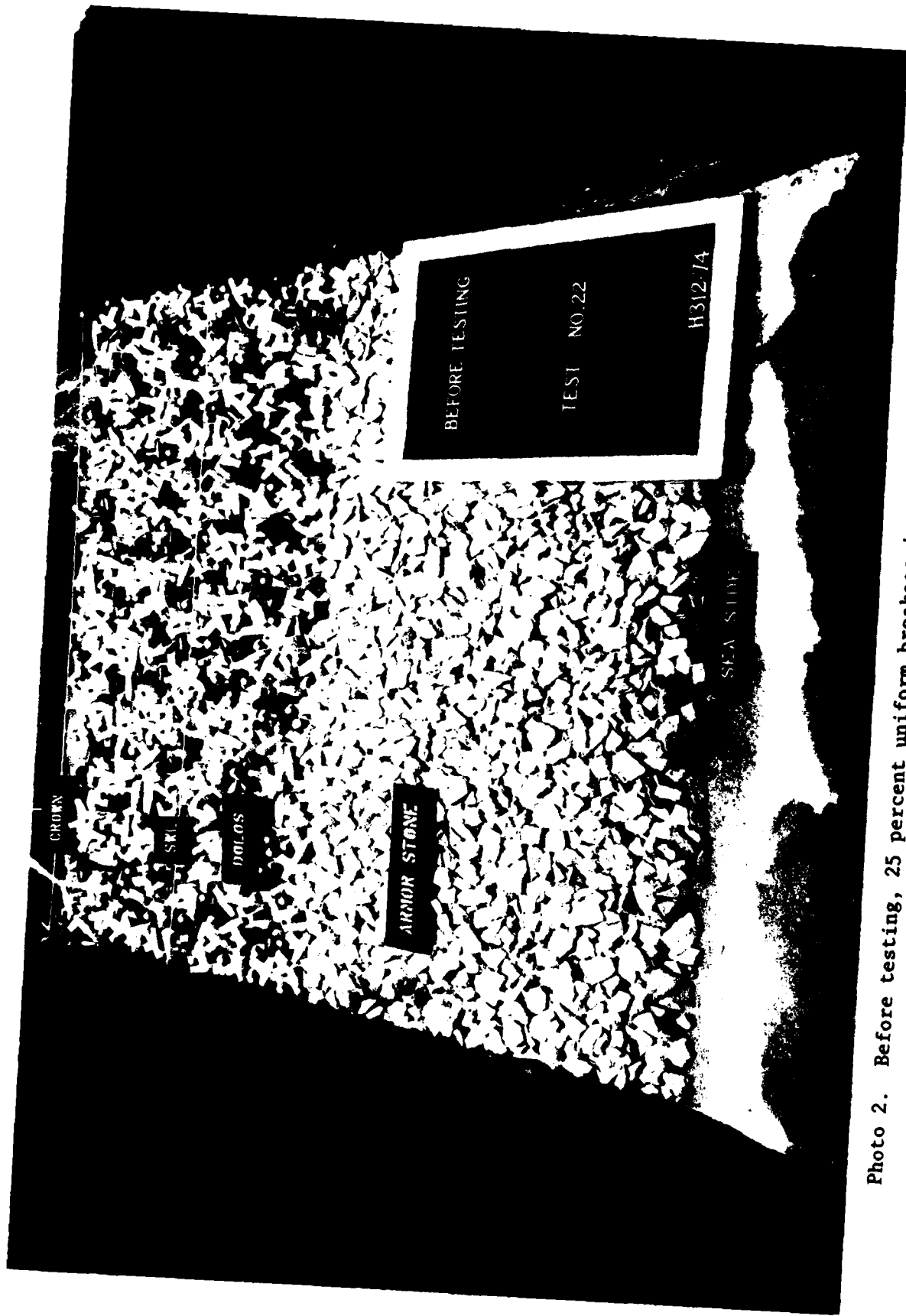

Photo 2. Before testing, 25 percent uniform breakage in top layer, nonbreaking waves



Photo 3. Before testing, 35 percent uniform breakage in top layer, nonbreaking waves



Photo 4. After testing, 15 percent uniform breakage in top layer, nonbreaking waves

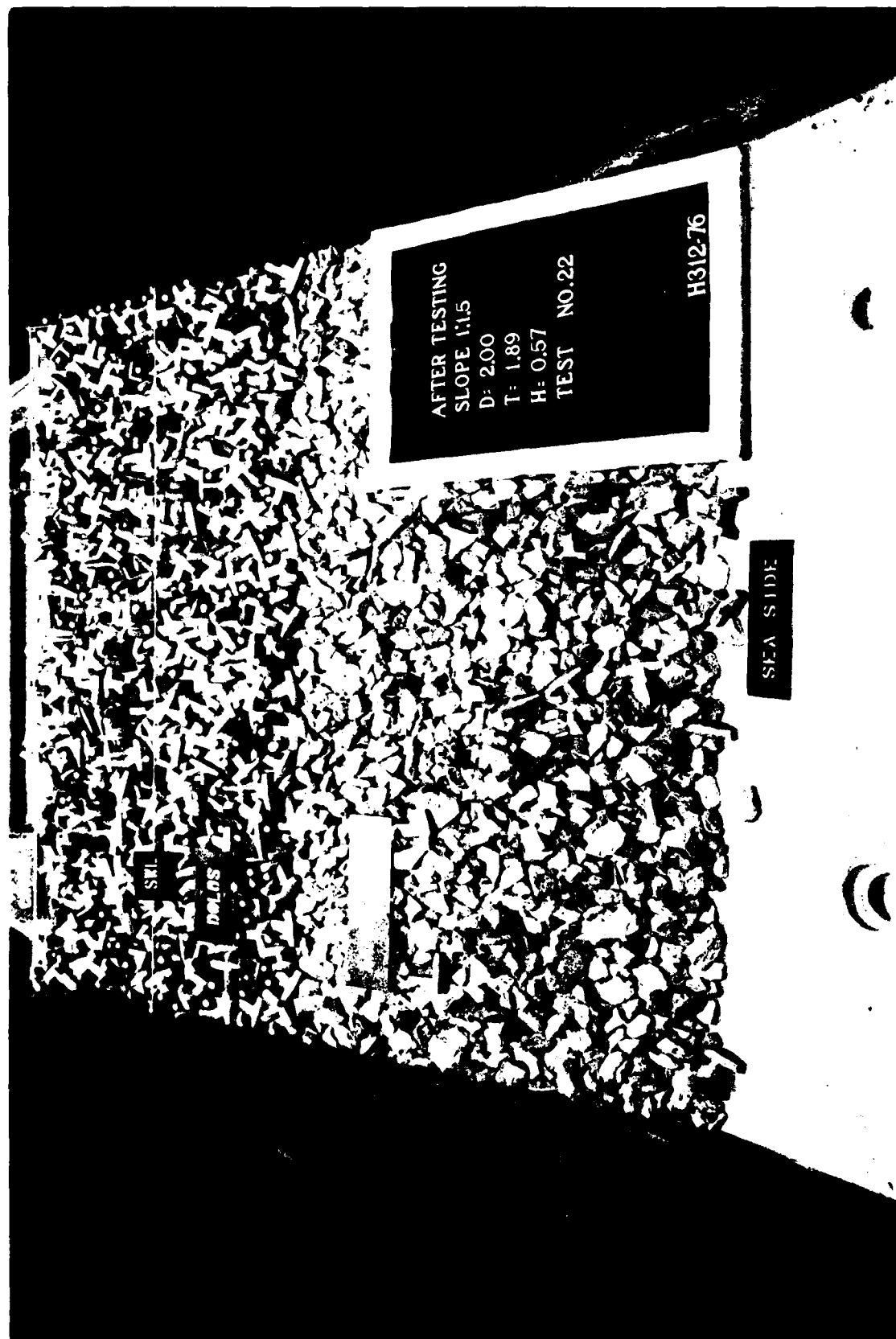

Photo 5. After testing, 25 percent uniform breakage in top layer, nonbreaking waves

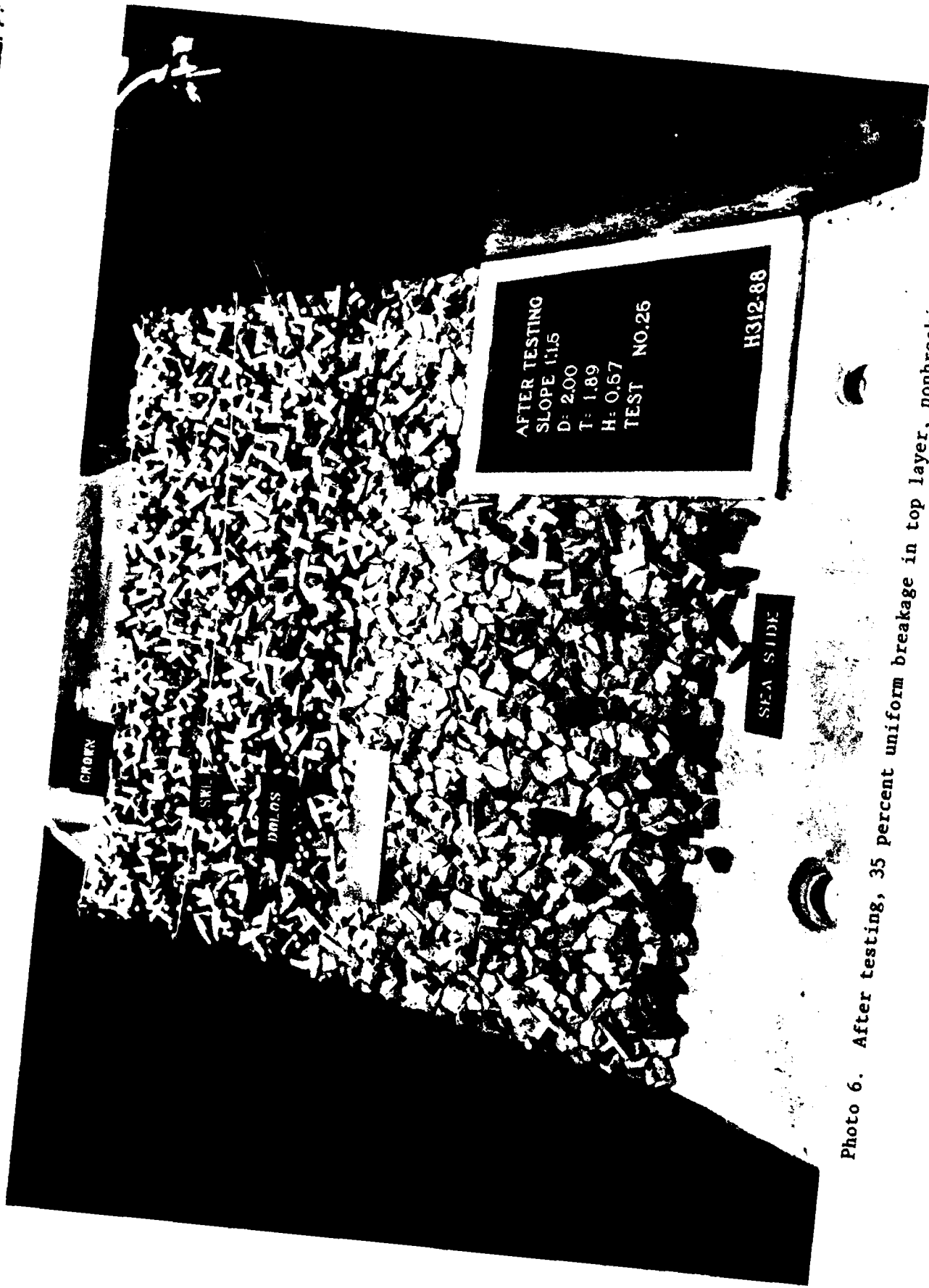

Photo 6. After testing, 35 percent uniform breakage in top layer, nonbreaking waves

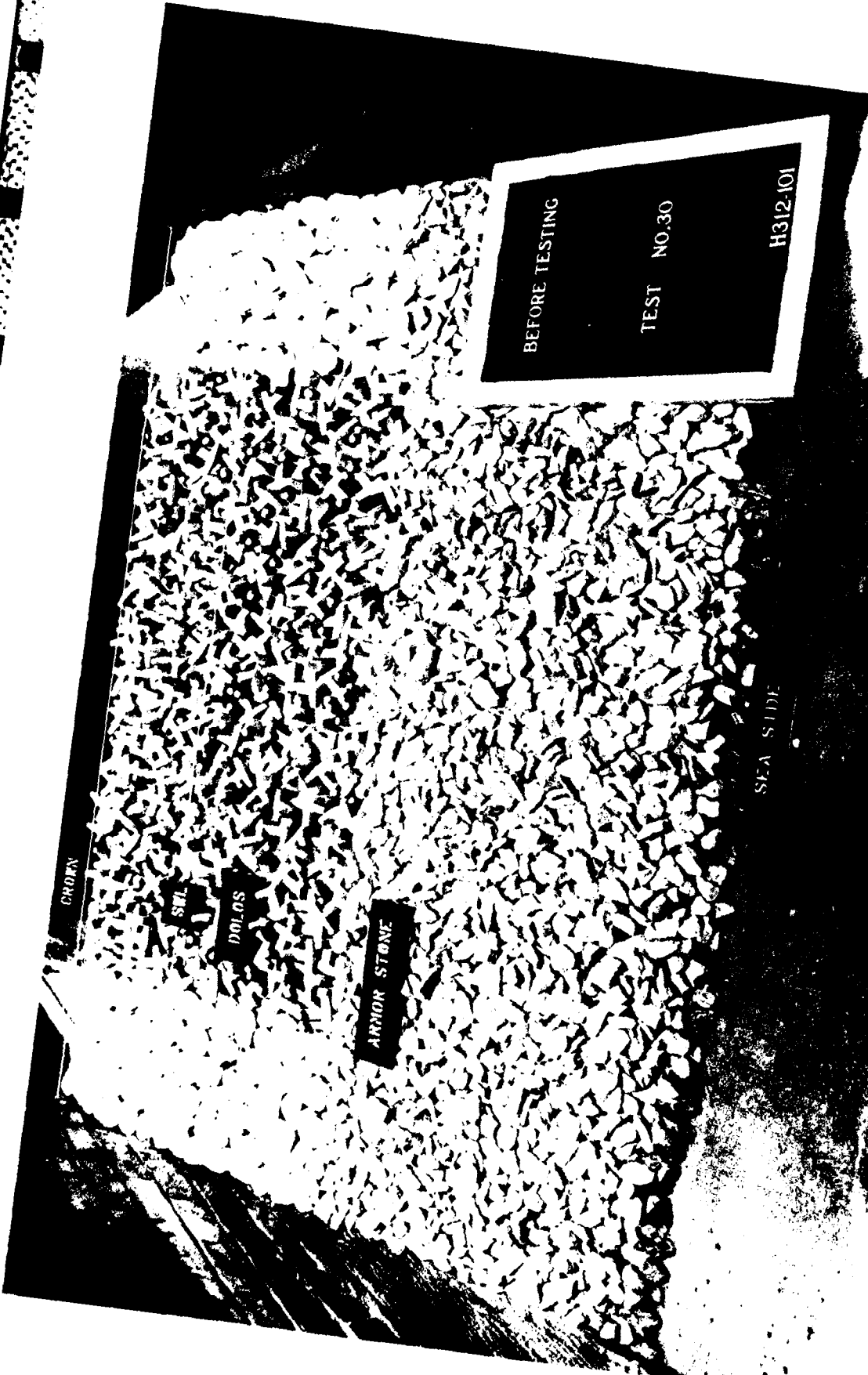

Photo 7. Before testing, 15 percent uniform breakage in bottom layer, nonbreaking waves

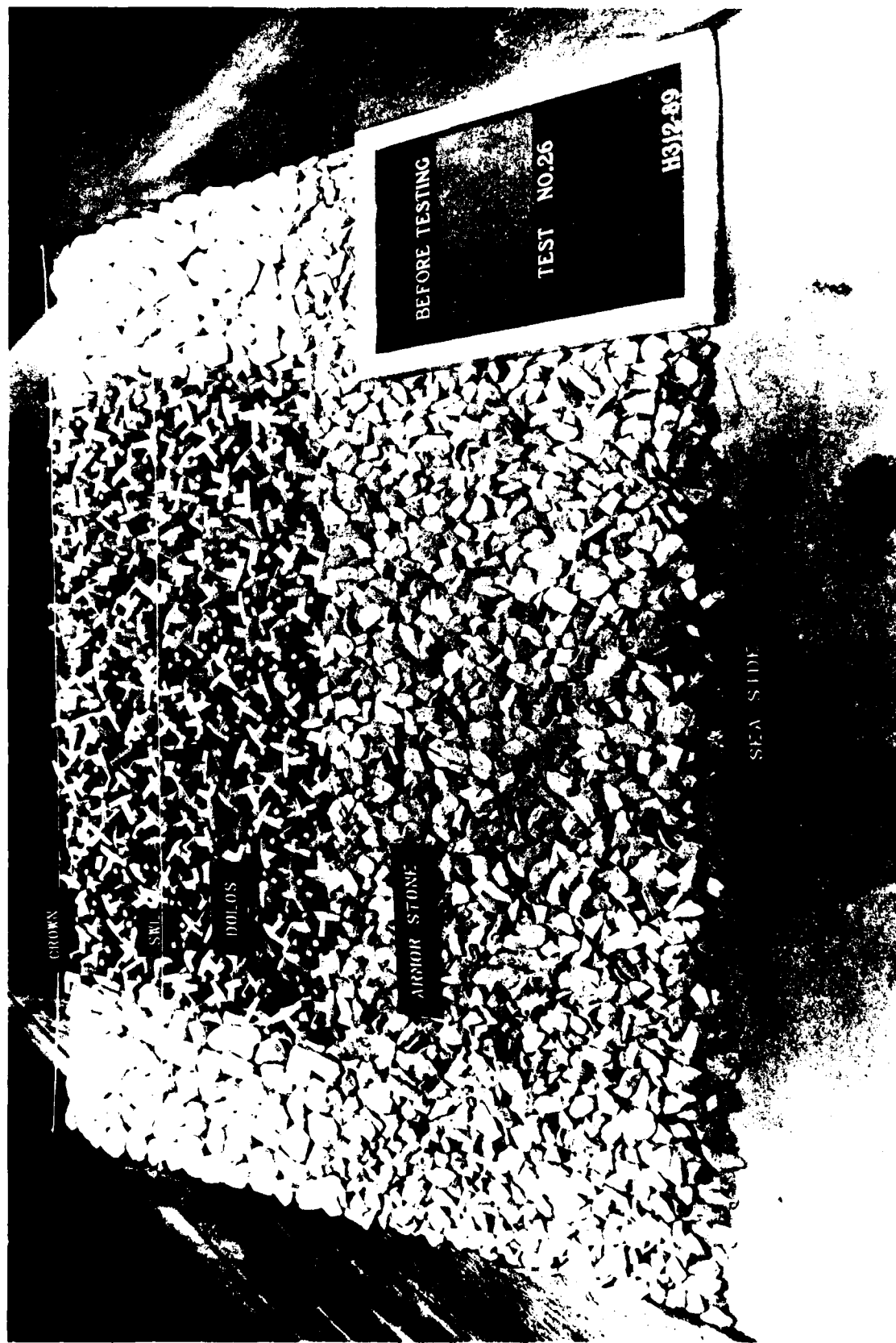

Photo 8. Before testing, 25 percent uniform breakage in bottom layer, nonbreaking waves



Photo 9. After testing, 15 percent uniform breakage in bottom layer, nonbreaking waves

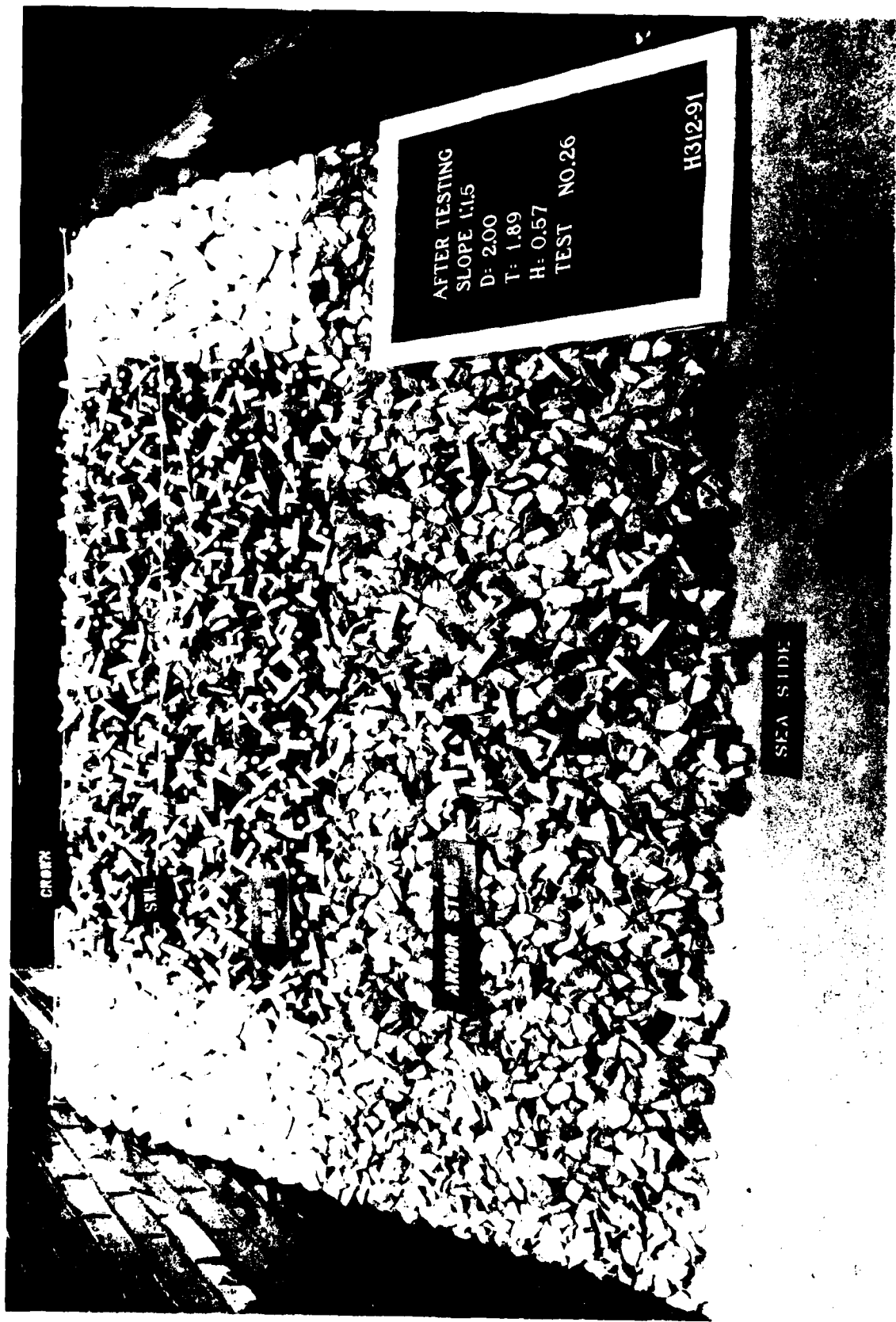

Photo 10. After testing, 25 percent uniform breakage in bottom layer, nonbreaking waves



Photo 11. Before testing, 7.5 percent uniform breakage in both layers, nonbreaking waves



Photo 12. Before testing, 10 percent uniform breakage in both layers, nonbreaking waves



Photo 13. Before testing, 15 percent uniform breakage in both layers, nonbreaking waves

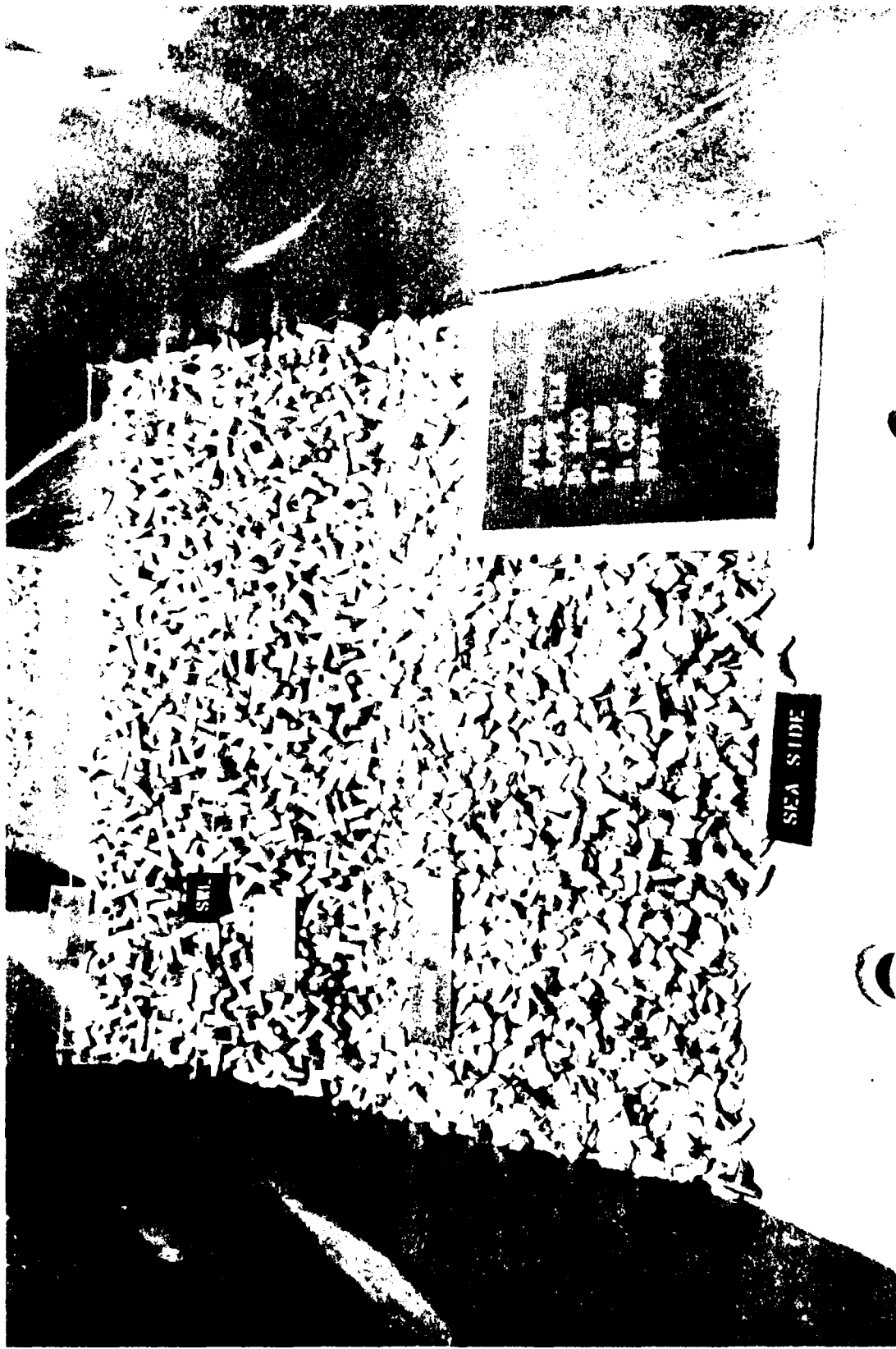

Photo 14. After testing, 7.5 percent uniform breakage in both layers, nonbreaking waves



Photo 15. After testing, 10 percent uniform breakage in both layers, nonbreaking waves

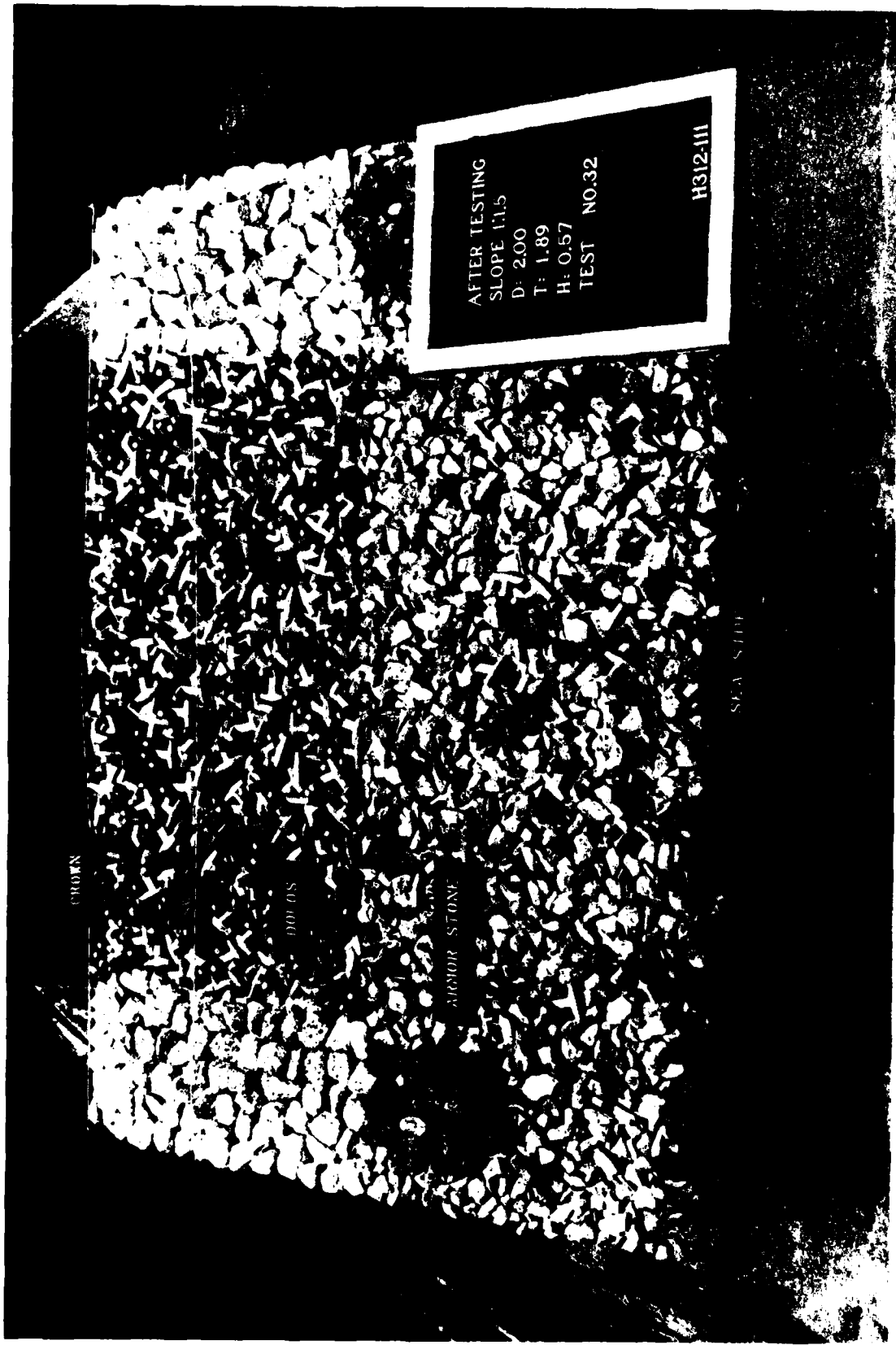

Photo 16. After testing, 15 percent uniform breakage in both layers, nonbreaking waves

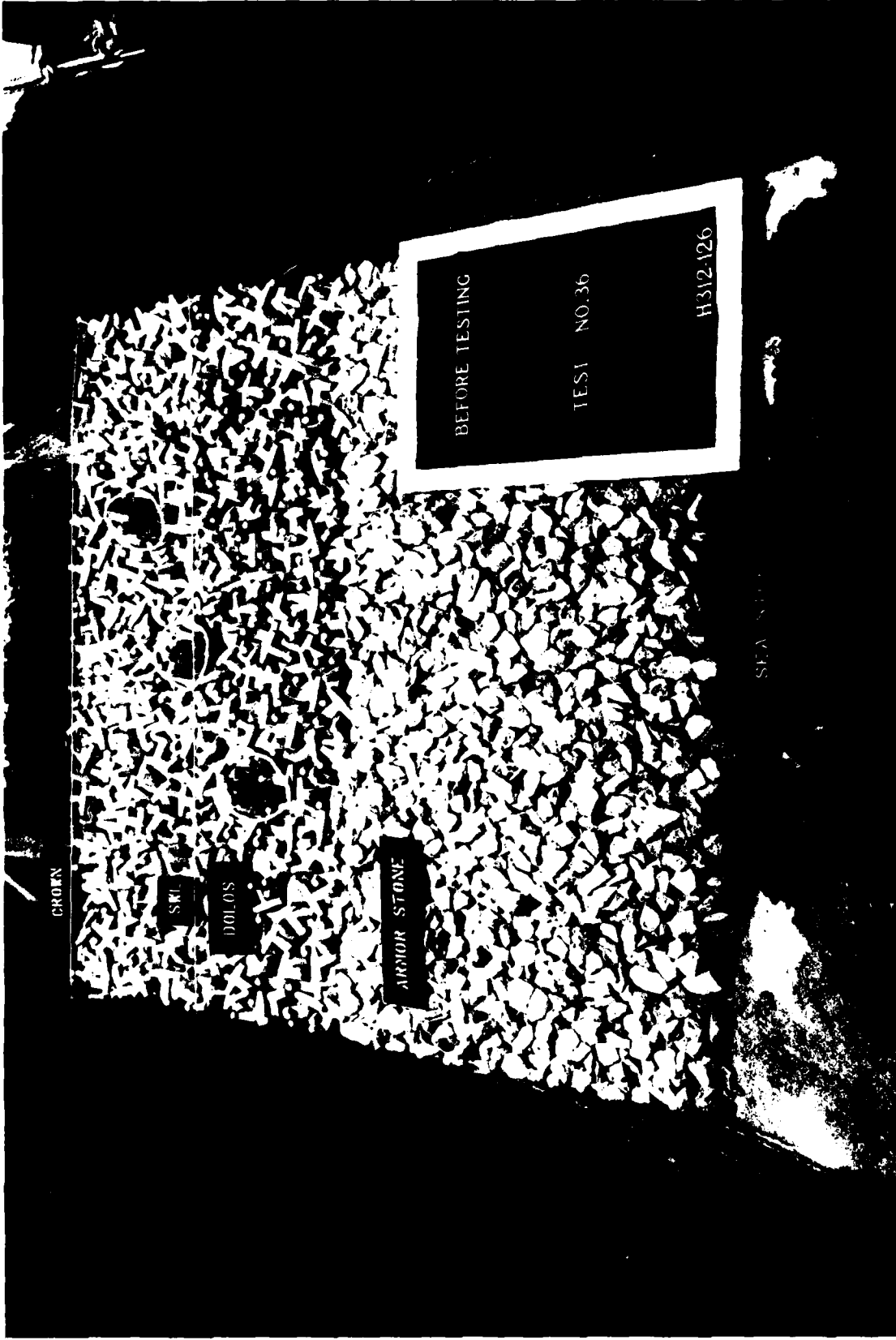

Photo 17. Before testing, 5-unit cluster breakage, nonbreaking waves



Photo 18. Before testing, 10-unit cluster breakage, nonbreaking waves

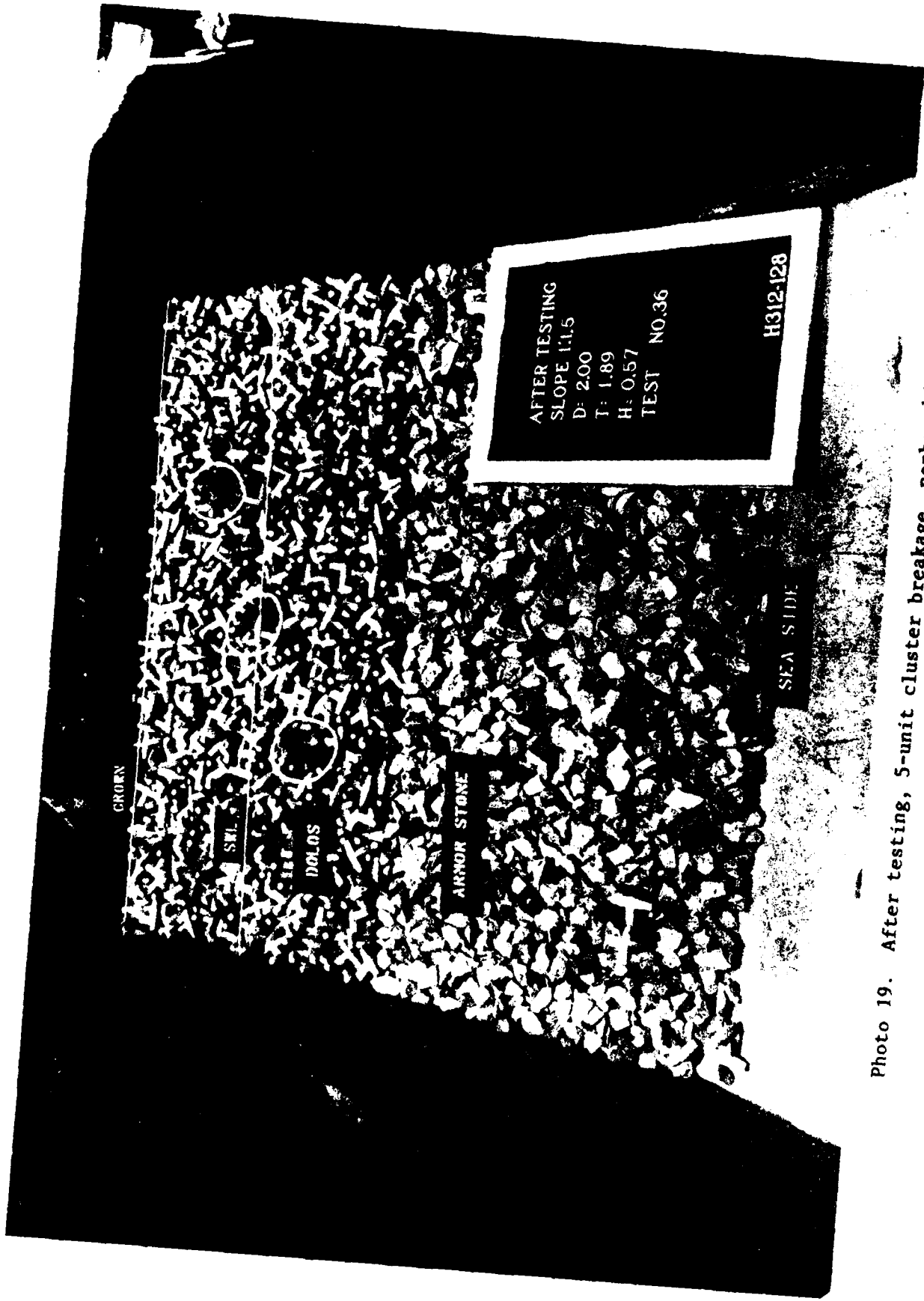

Photo 19. After testing, 5-unit cluster breakage, nonbreaking waves

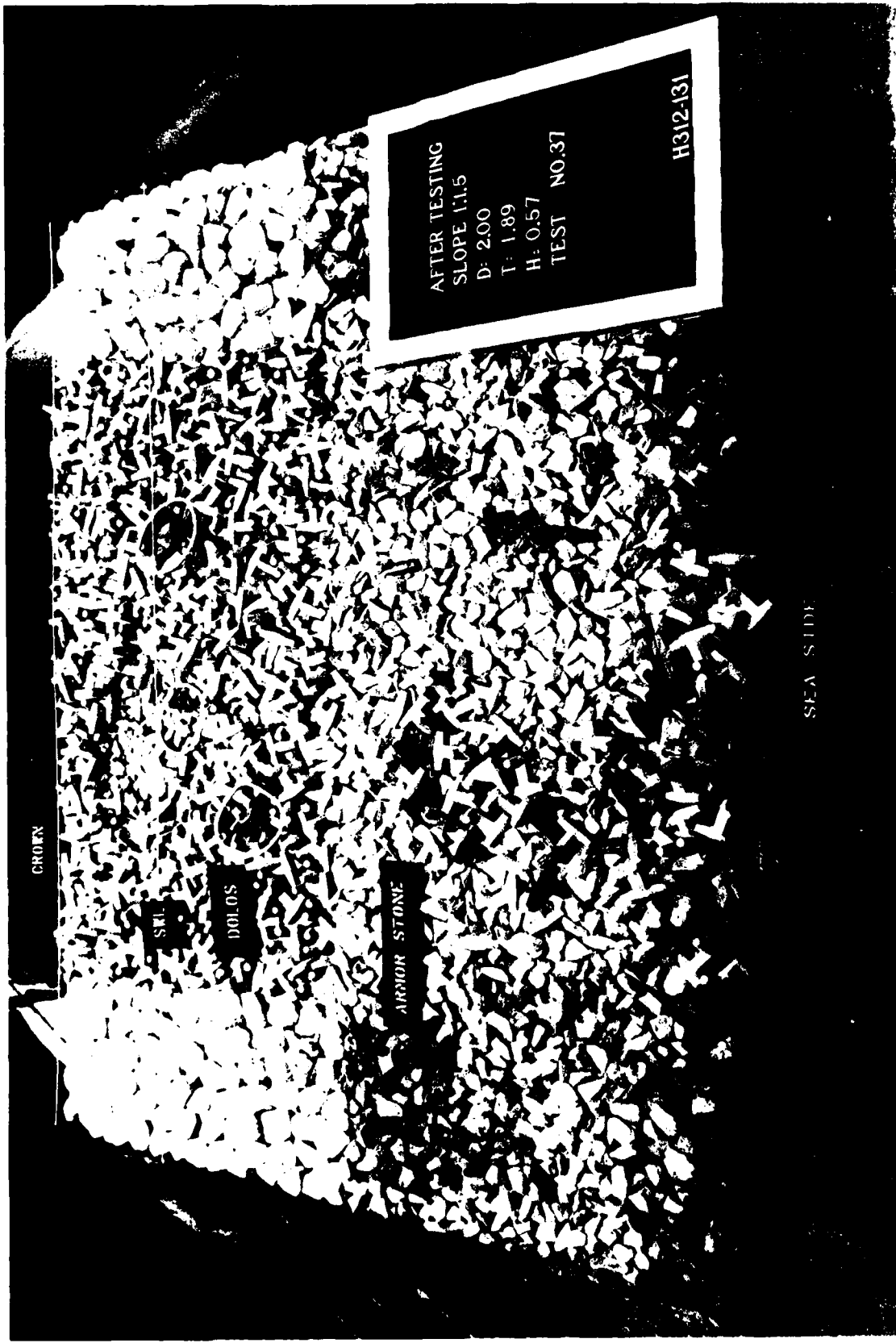

Photo 20. After testing, 10-unit cluster breakage, nonbreaking waves

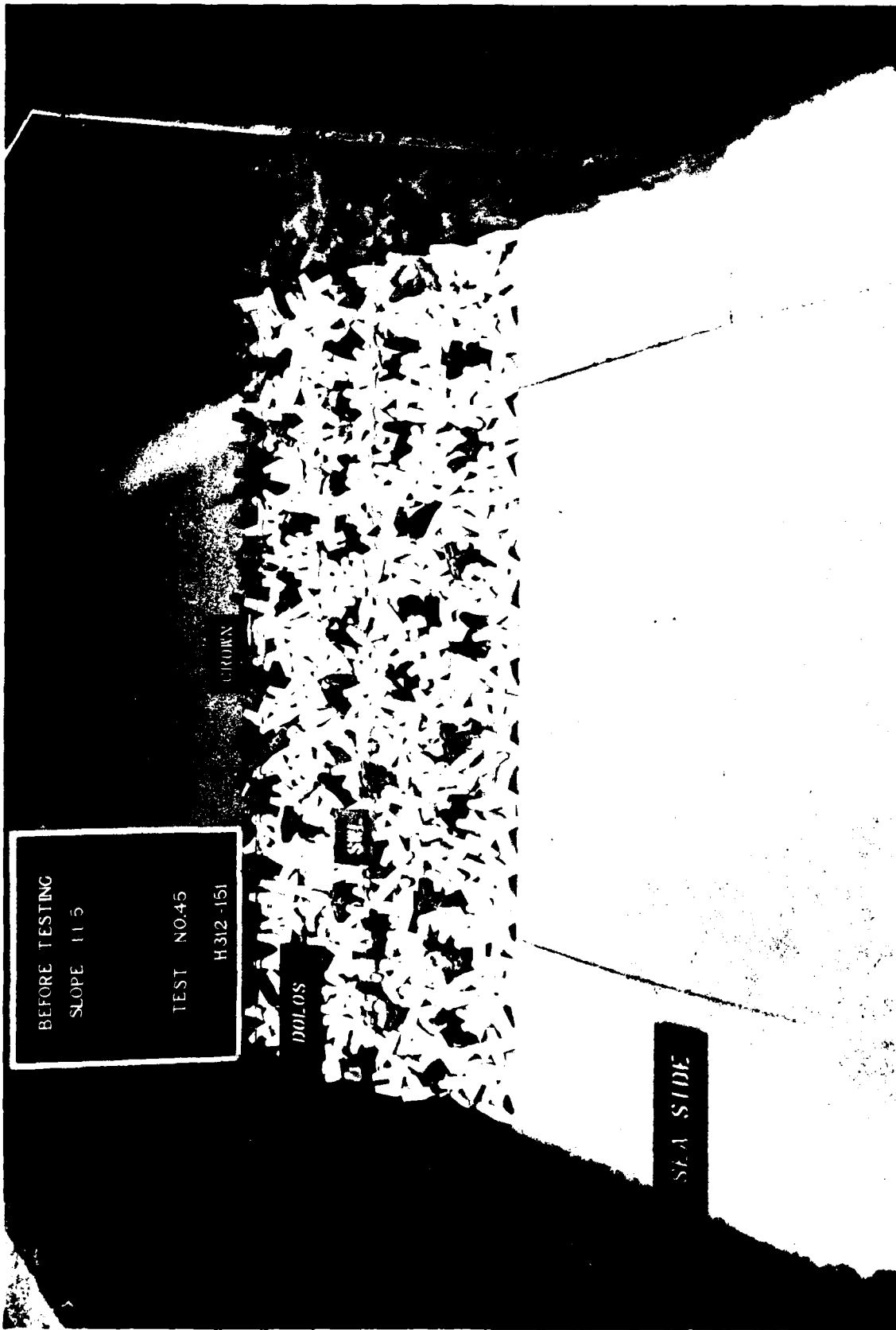

Photo 21. Before testing, 25 percent uniform breakage in top layer, breaking waves

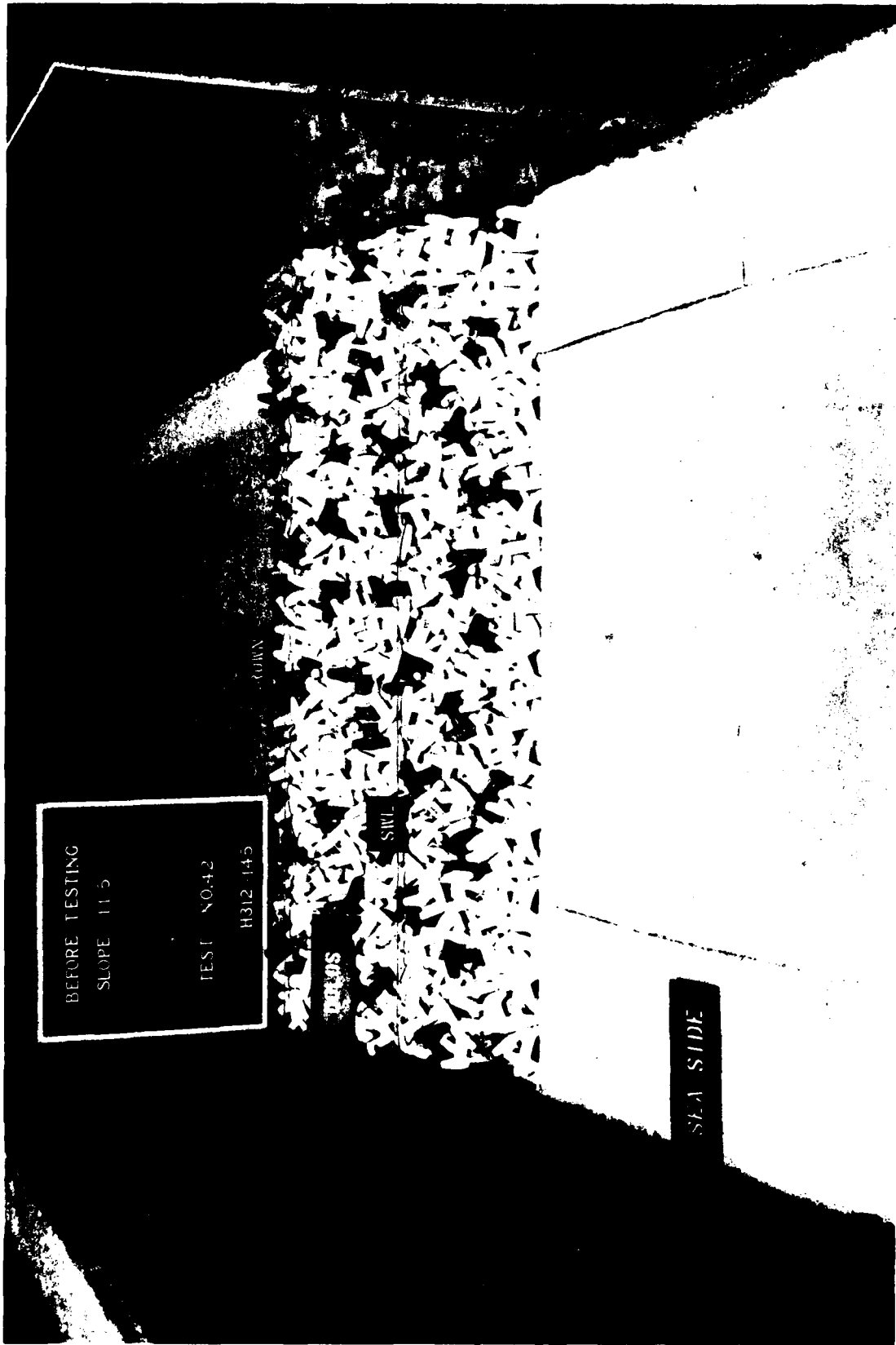

Photo 22. Before testing, 20 percent uniform breakage in top layer, breaking waves

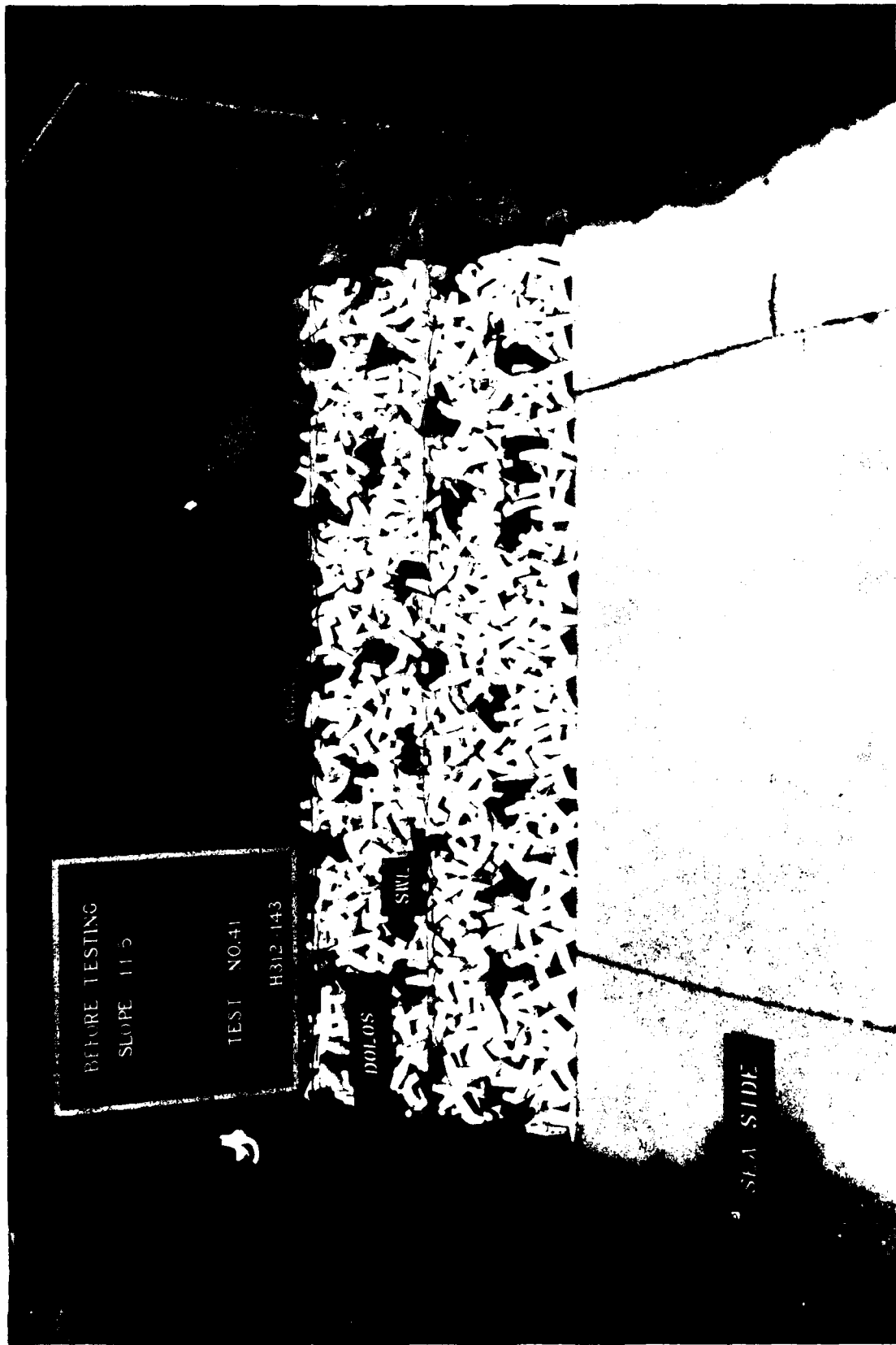

Photo 23. Before testing, 15 percent uniform breakage in top layer, breaking waves

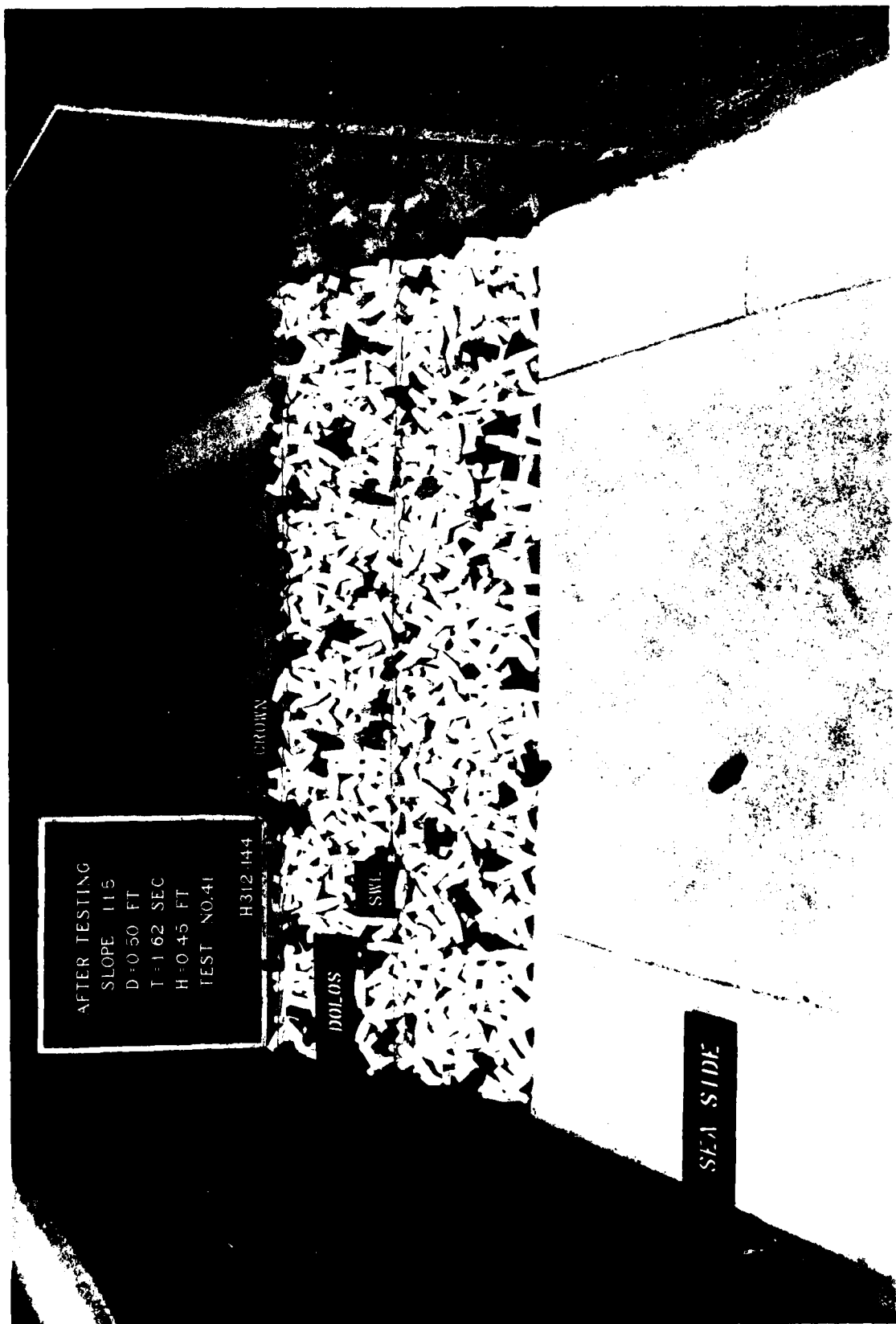

Photo 24. After testing, 15 percent uniform breakage in top layer, breaking waves

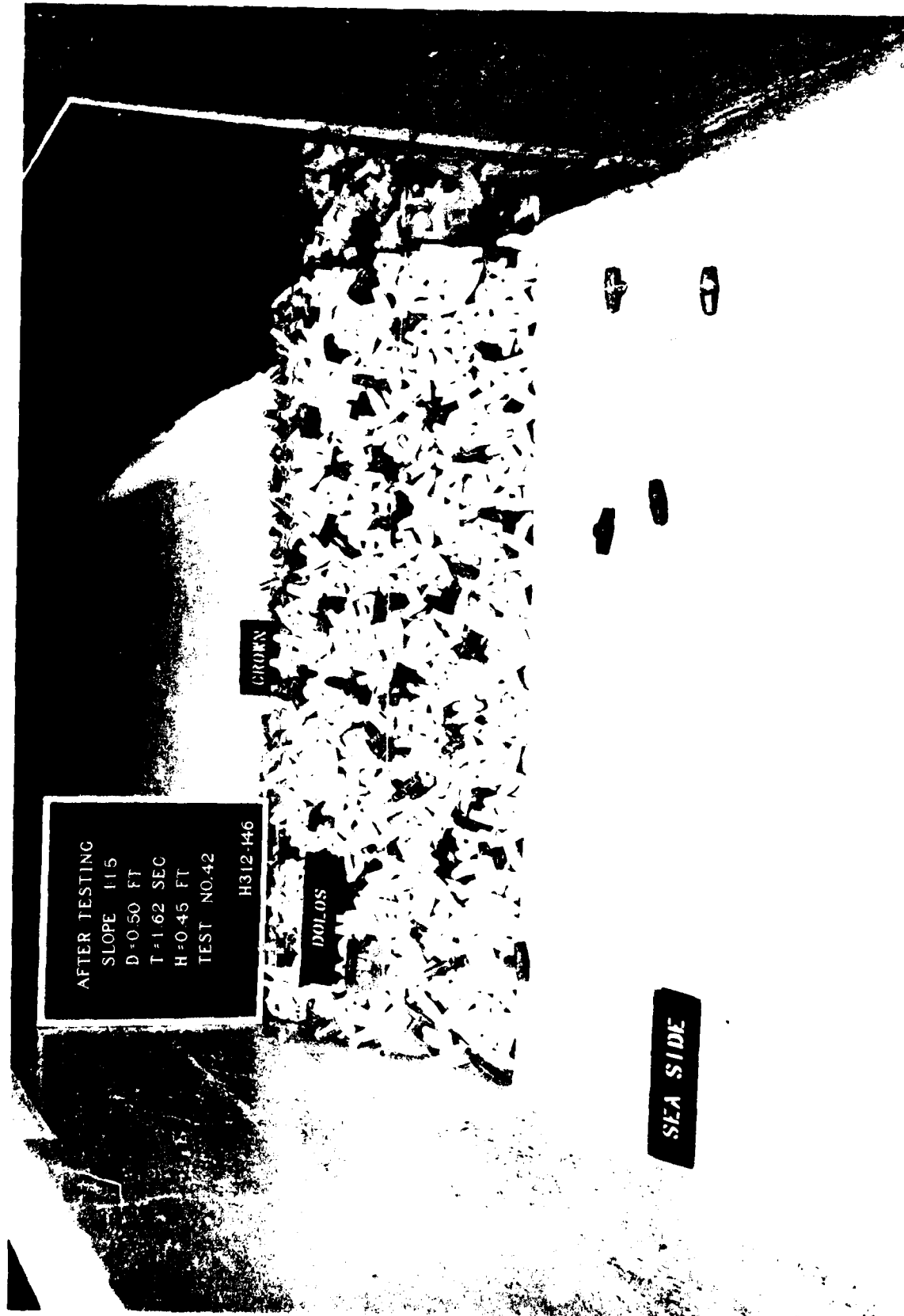

Photo 25. After testing, 20 percent uniform breakage in top layer, breaking waves

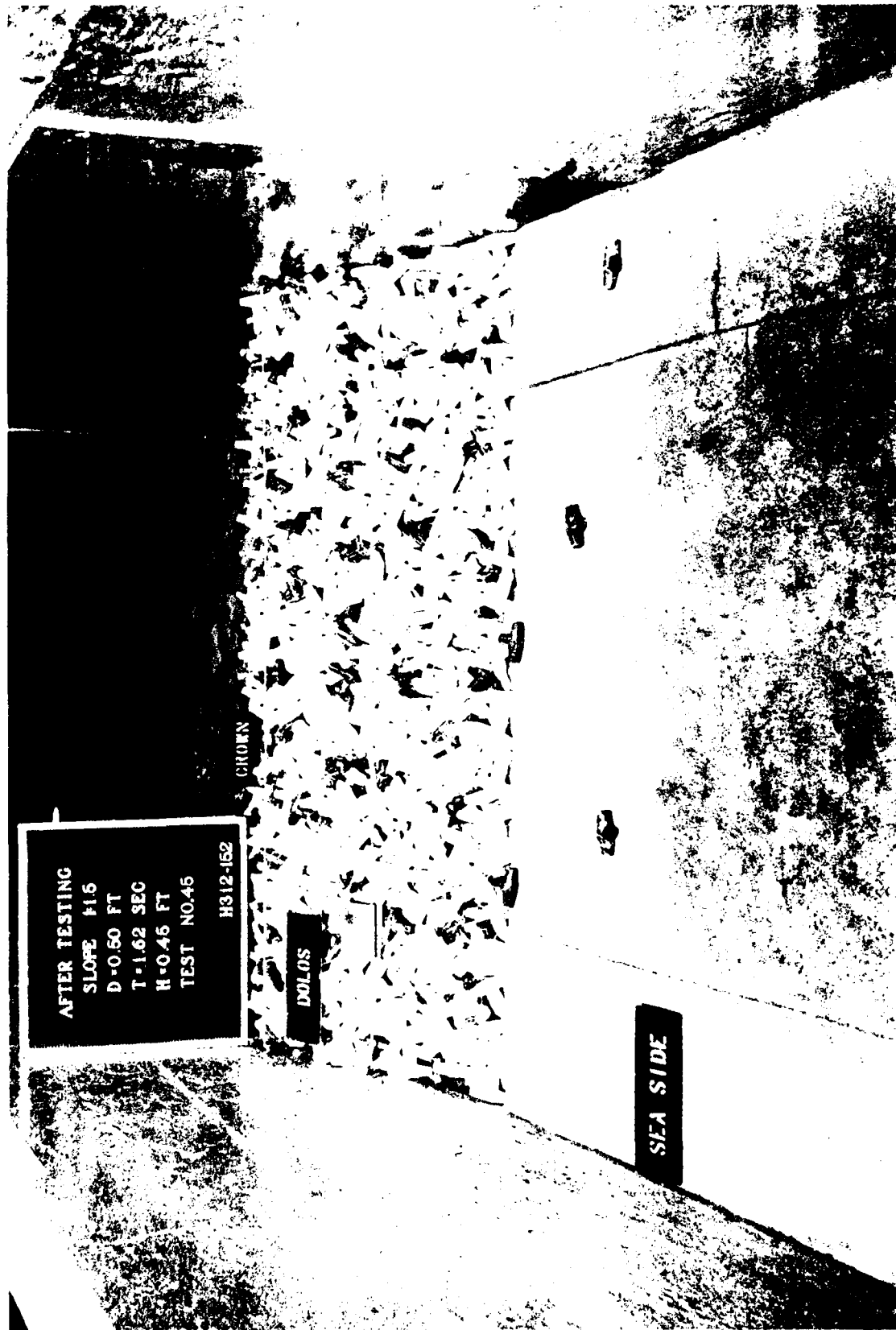

Photo 26. After testing, 25 percent uniform breakage in top layer, breaking waves



Photo 27. Before testing, 20 percent uniform breakage in bottom layer, breaking waves

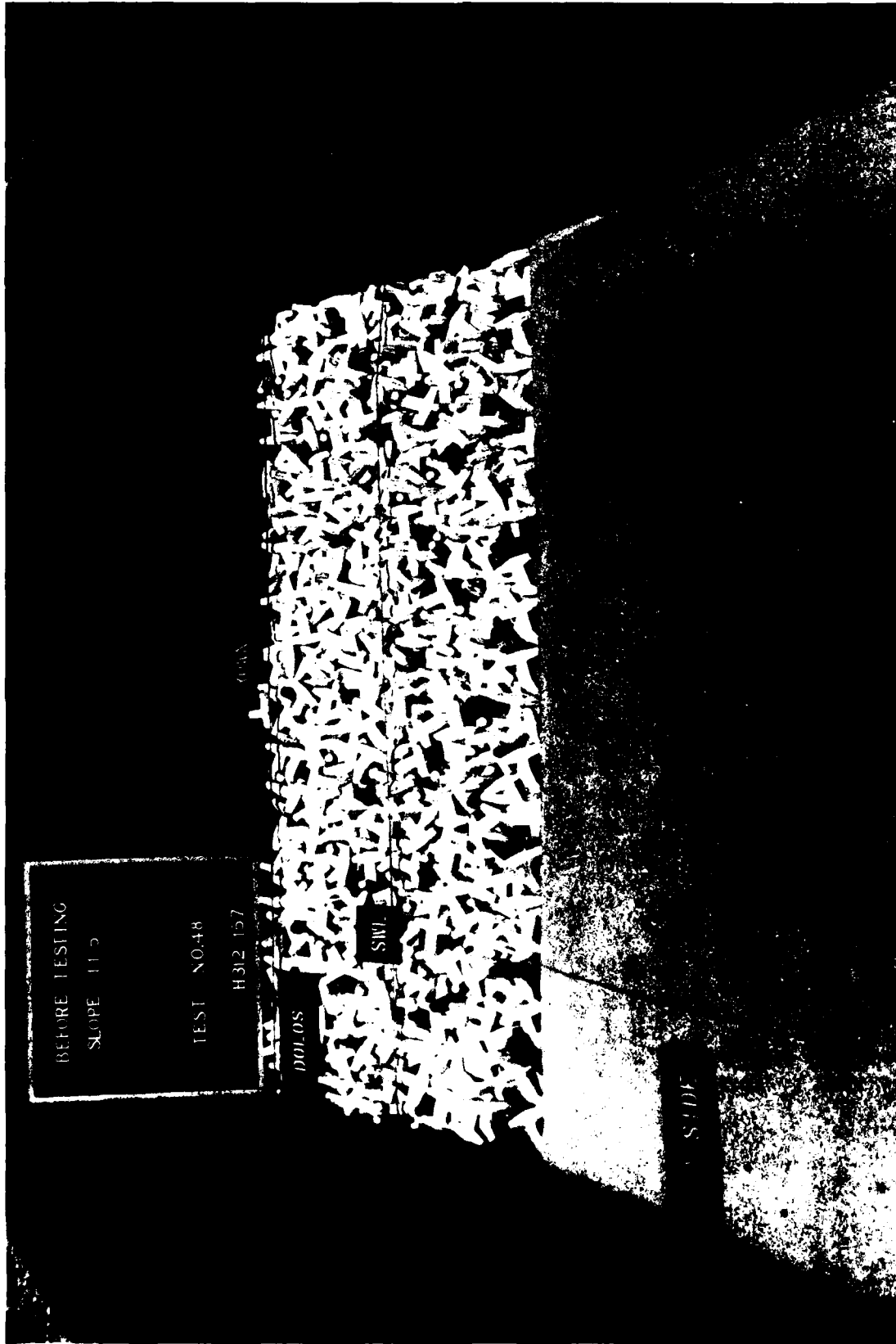

Photo 28. Before testing, 15 percent uniform breakage in bottom layer, breaking waves

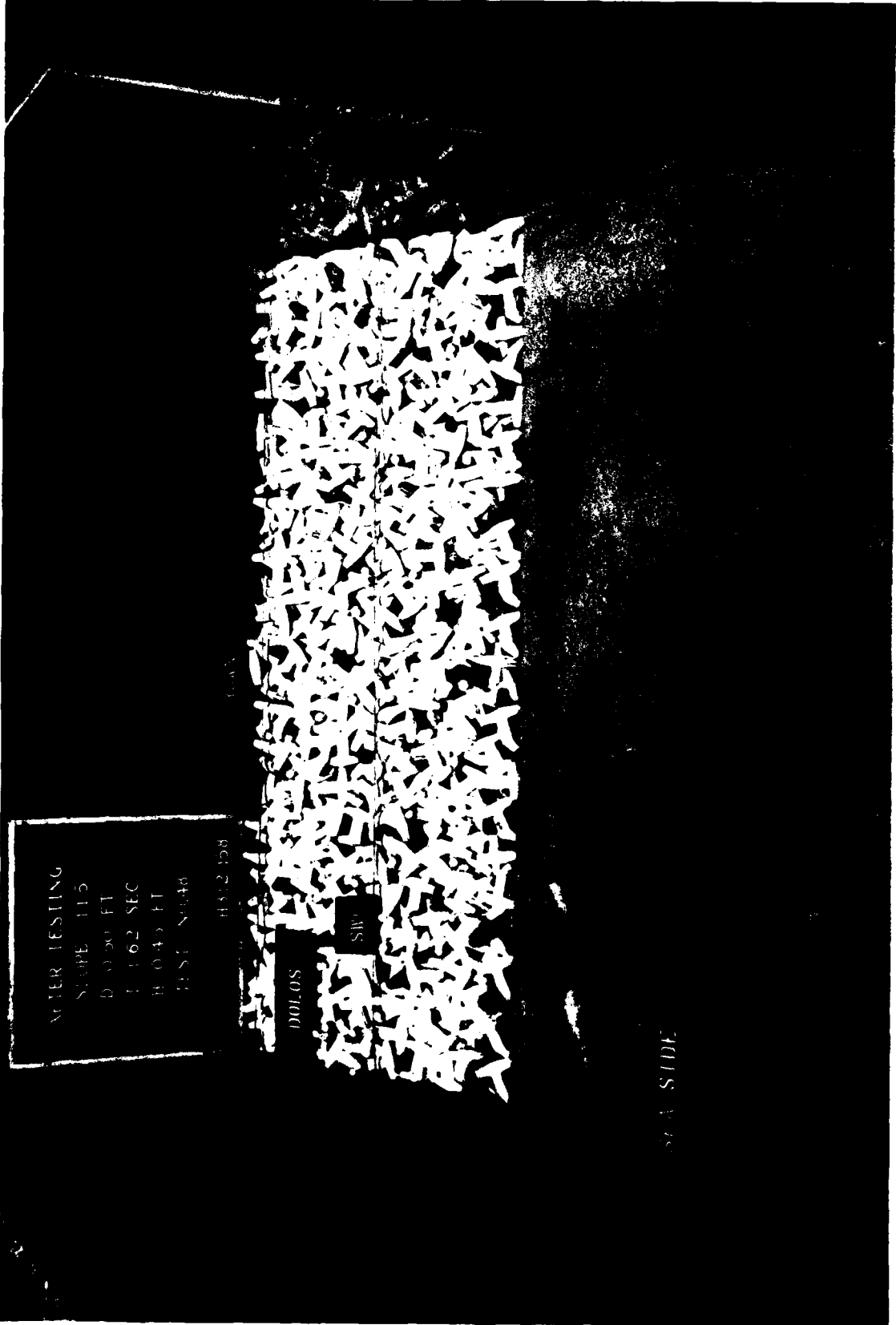

Photo 29. After testing, 15 percent uniform breakage in bottom layer, breaking waves



WATER TESTING
SECTION
0.000 ft
3.162 SEC
DUMOS
U.S. NAVY
8312-100

DUMOS

Photo 30. After testing, 20 percent uniform breakage in bottom layer, breaking waves

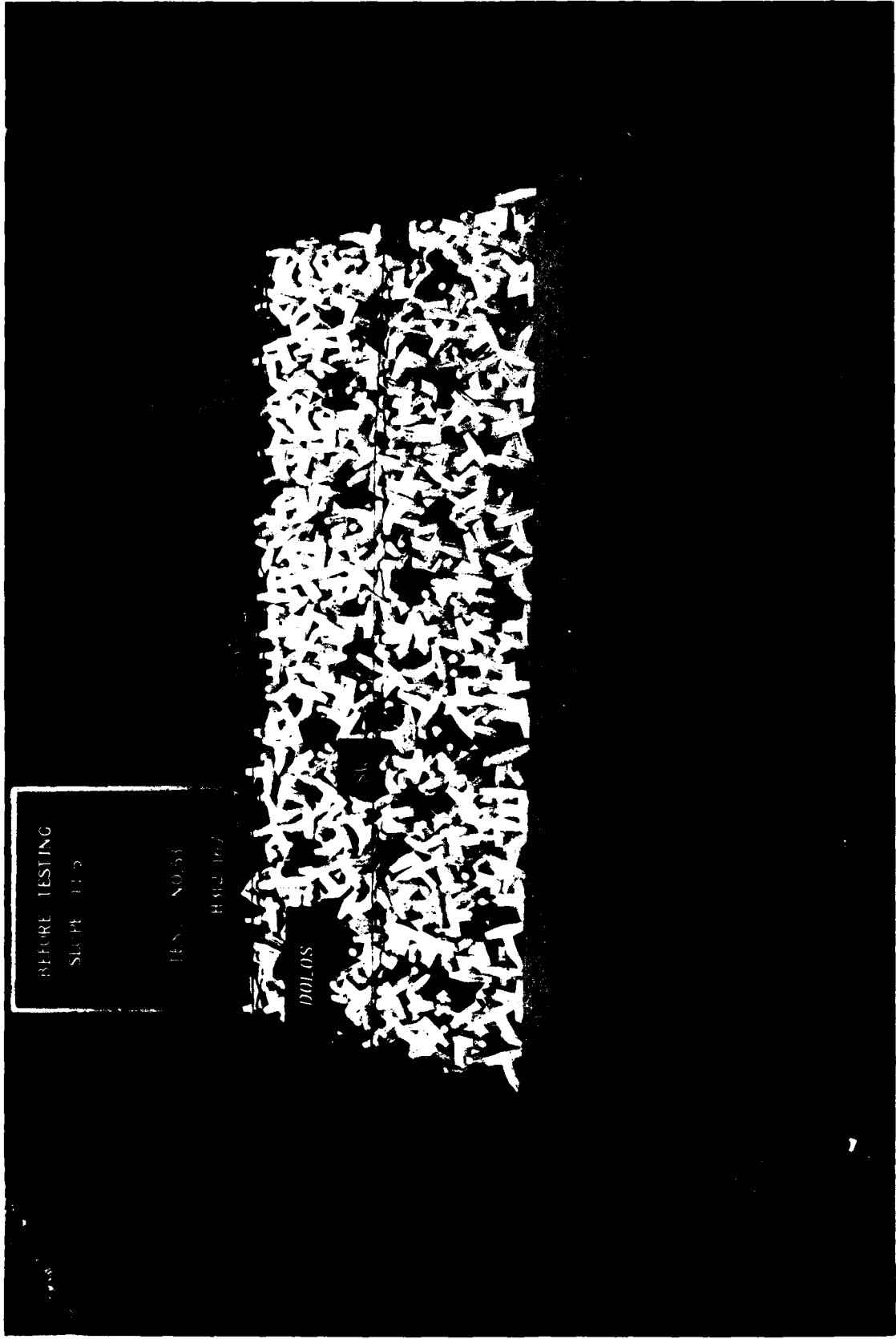

Photo 31. Before testing, 12.5 percent uniform breakage in both layers, breaking waves

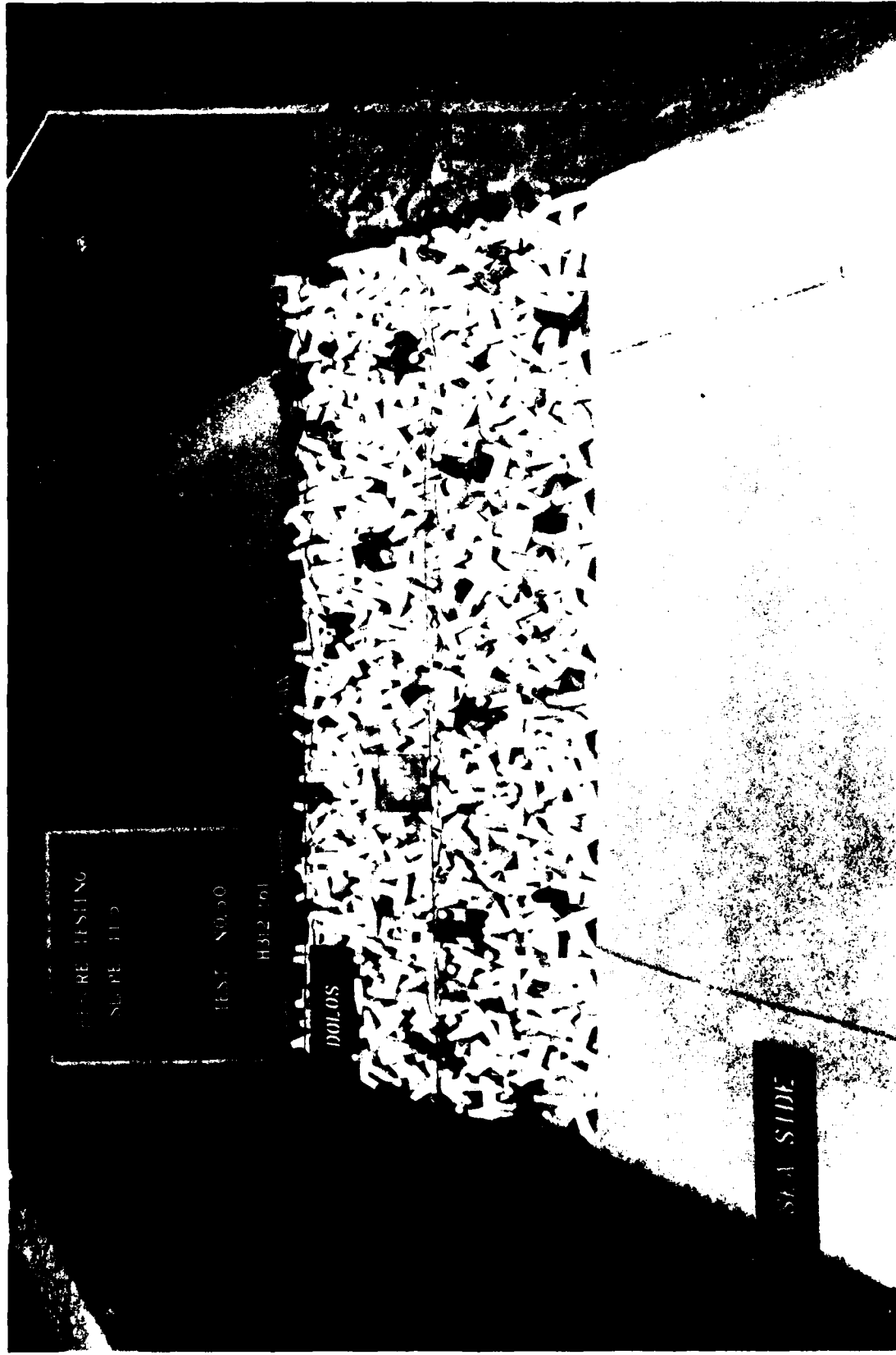

Photo 32. Before testing, 7.5 percent uniform breakage in both layers, breaking waves



AFTER TESTING
SLOPE 1:1.5
D: 0.50 FT
T: 1.62 SEC
H: 0.45 FT
TEST NO. 50
H 312-162

DOLLOS

SILL

SEA SIDE

Photo 33. After testing, 7.5 percent uniform breakage in both layers, breaking waves

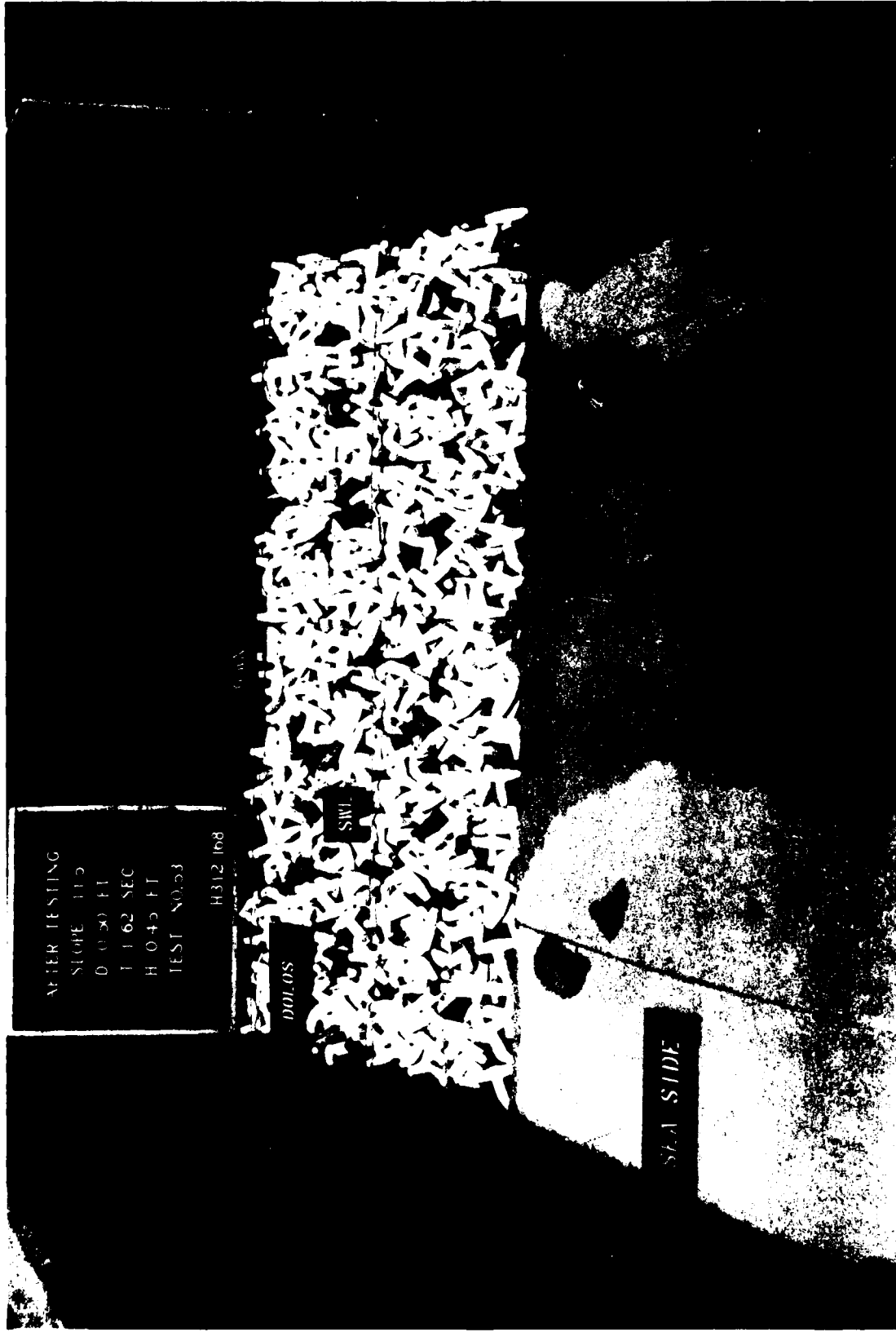

Photo 34. After testing, 12.5 percent uniform breakage in both layers, breaking waves

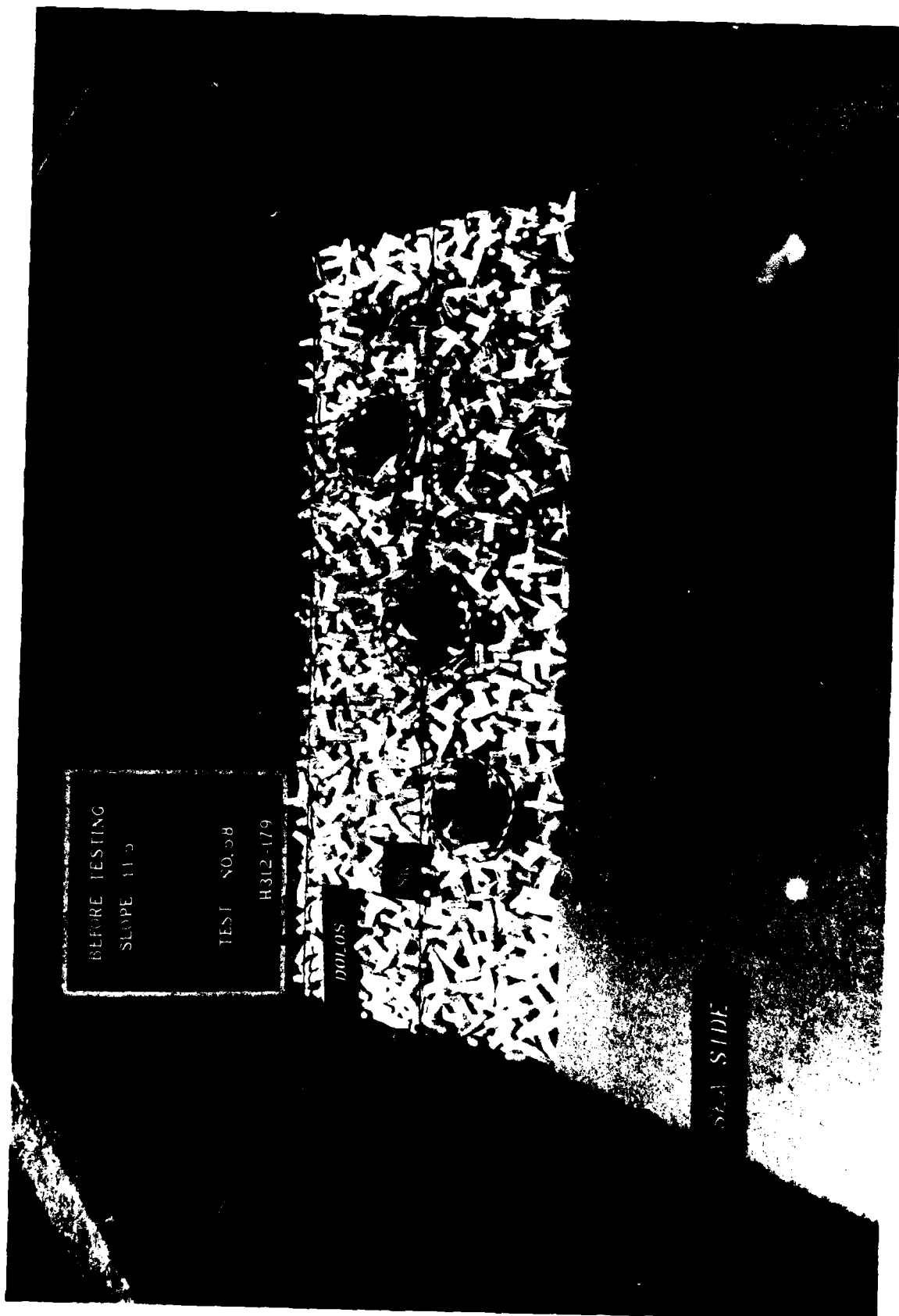
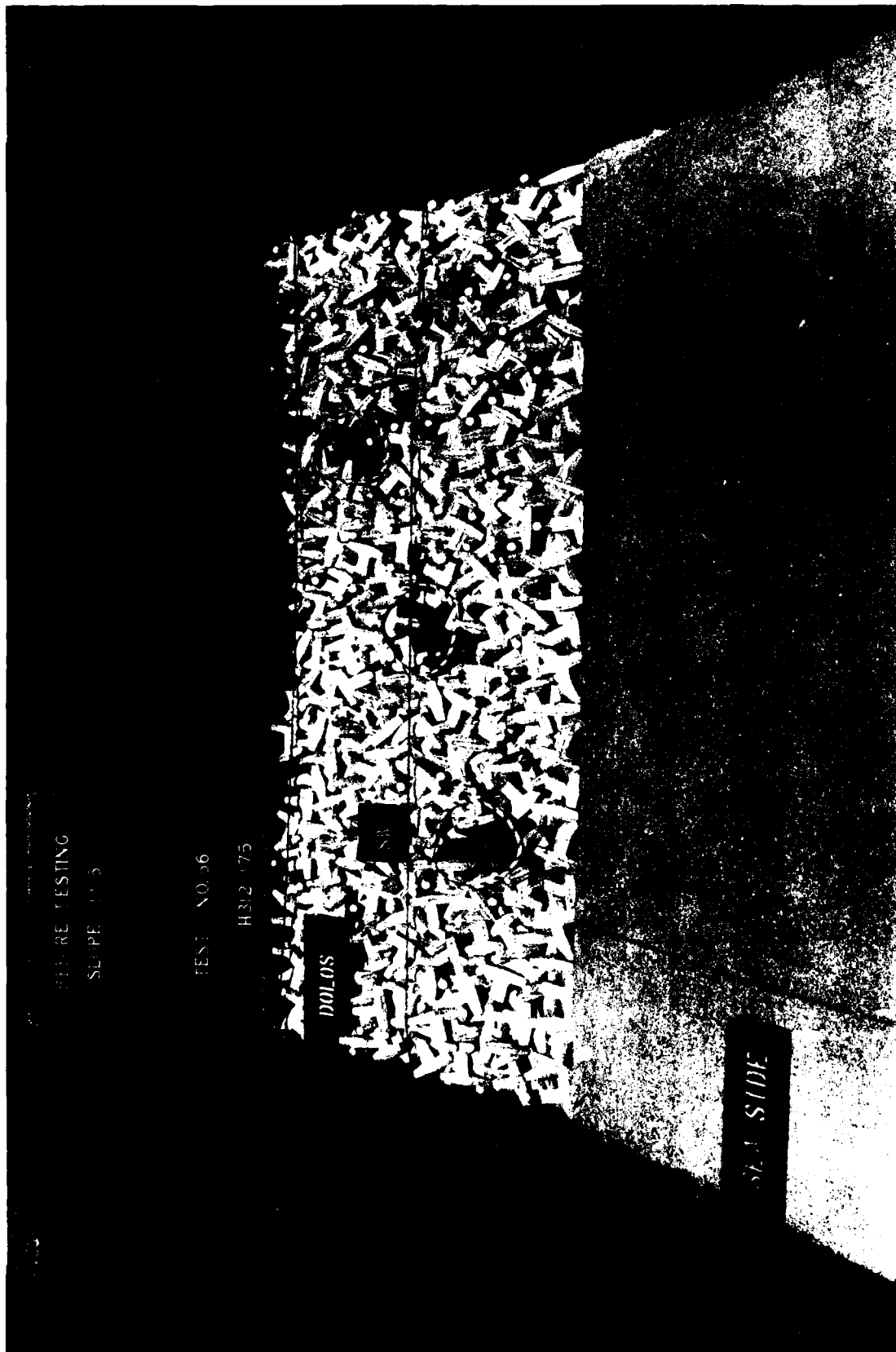

Photo 35. Before testing, 10-unit cluster breakage, breaking waves



PRESSURE TESTING
SLOPE 1:1.5

TEST NO. 36

H32-75

DOL

SEA SIDE

Photo 36. Before testing, 5-unit cluster breakage, breaking waves

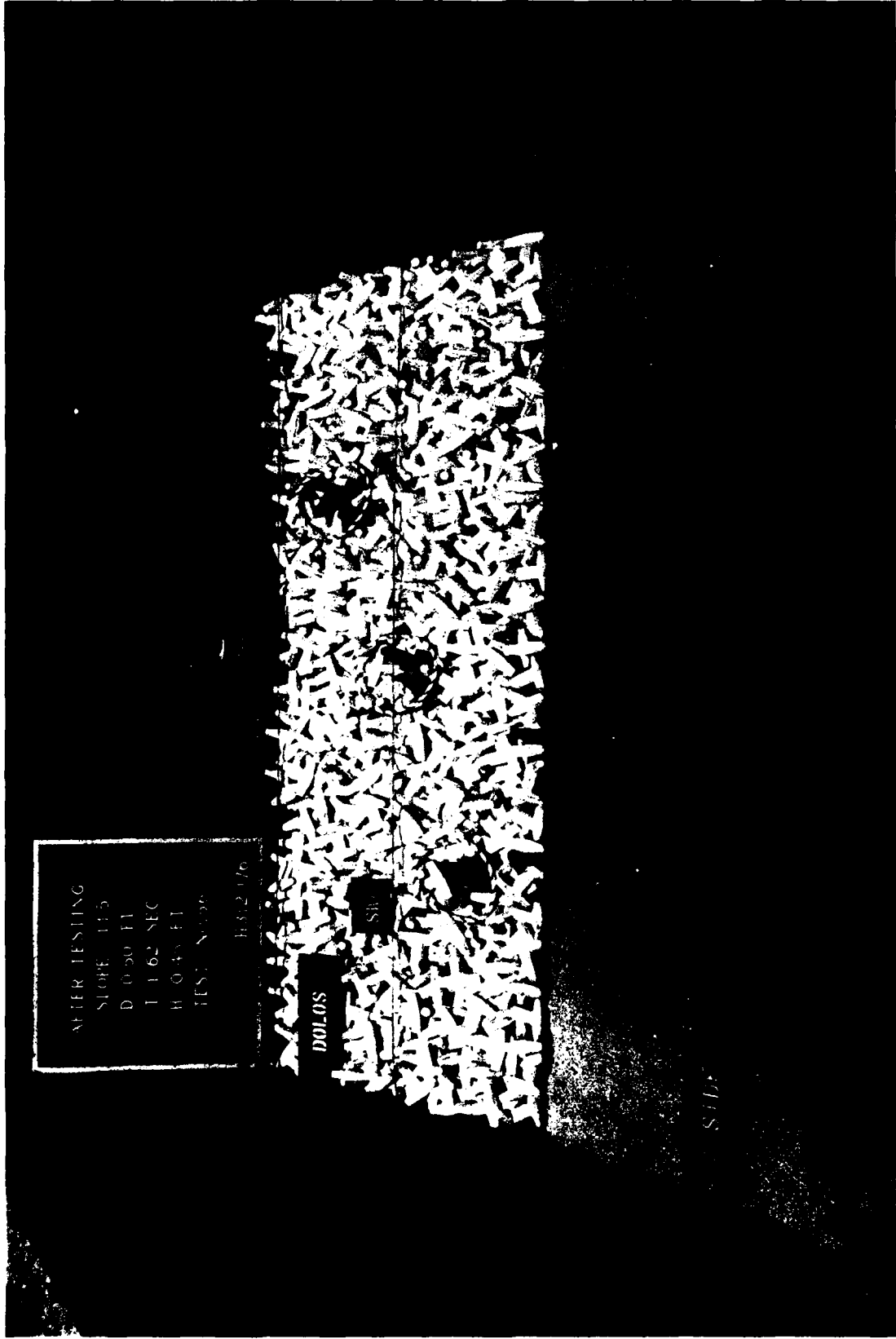

AFTR TESTING
SLOPE 115
D 0.50 FT
T 1.62 SEC
H 0.45 FT
TEST NUMBER
H32176

DOLDS

S117

Photo 37. After testing, 5-unit cluster breakage, breaking waves

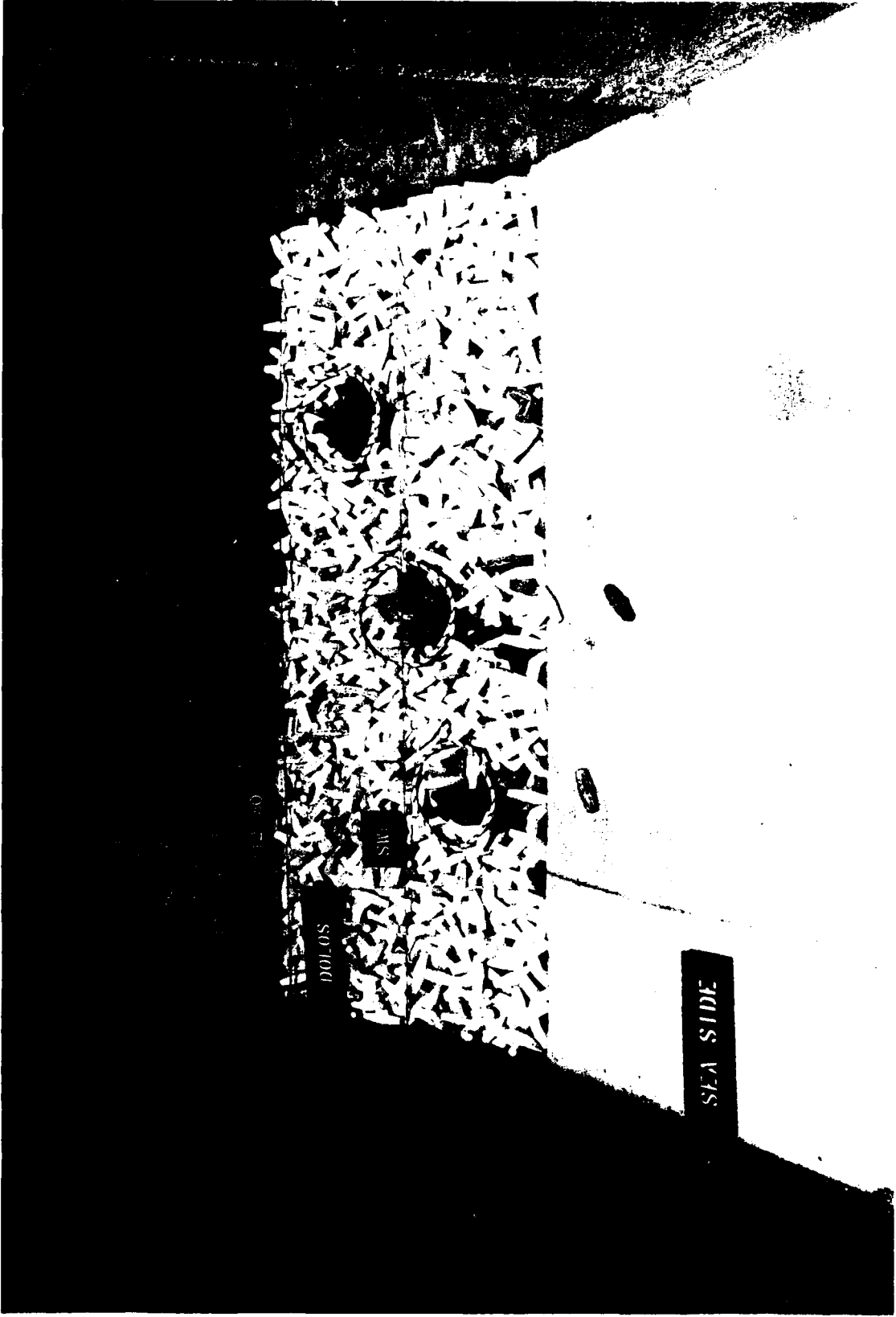
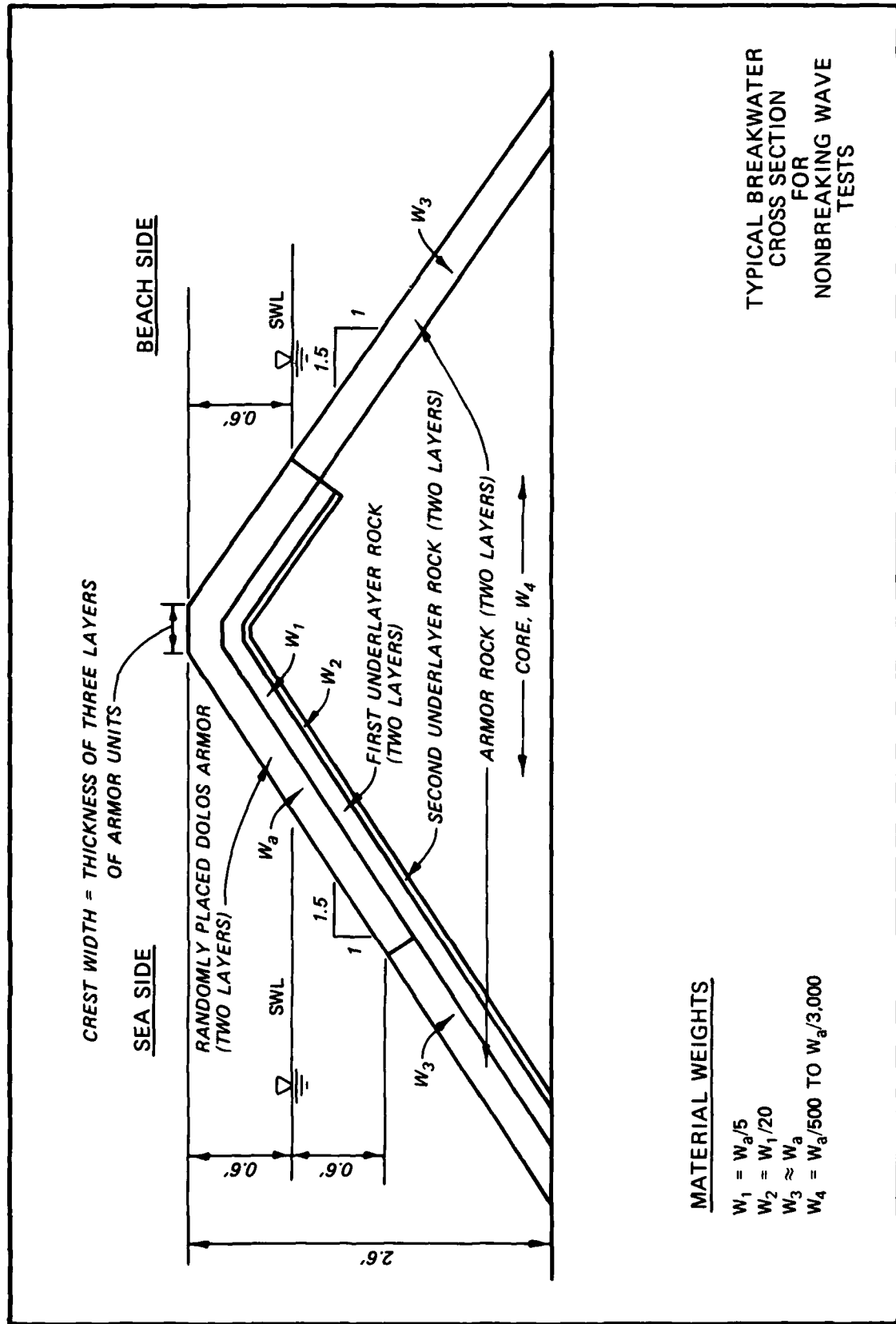

Photo 38. After testing, 10-unit cluster breakage, breaking waves



MATERIAL WEIGHTS

- $W_1 = W_a/5$
- $W_2 = W_1/20$
- $W_3 \approx W_a$
- $W_4 = W_a/500$ TO $W_a/3,000$

TYPICAL BREAKWATER
CROSS SECTION
FOR
NONBREAKING WAVE
TESTS

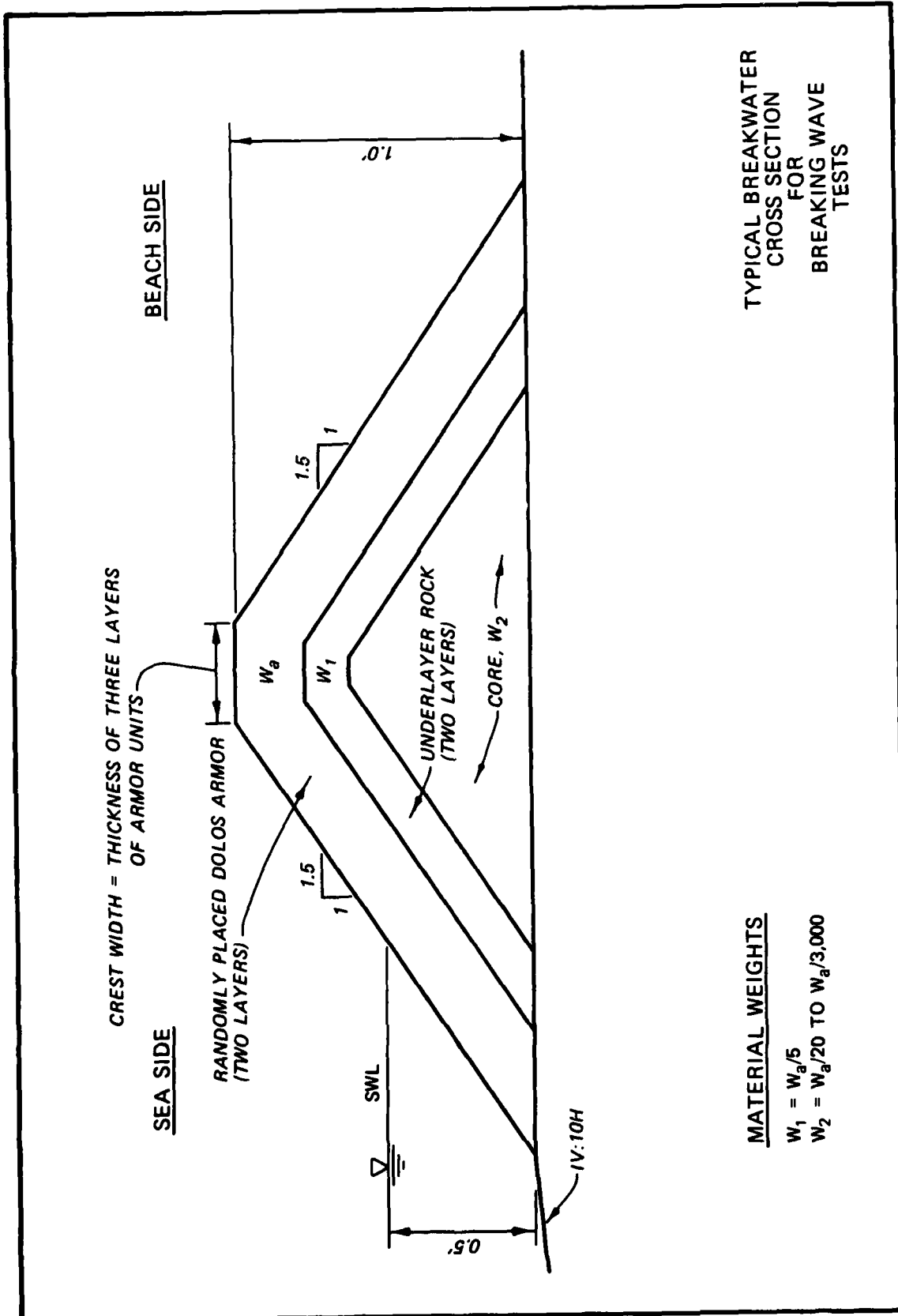

TYPICAL BREAKWATER
CROSS SECTION
FOR
BREAKING WAVE
TESTS

MATERIAL WEIGHTS
 $W_1 = W_a/5$
 $W_2 = W_a/20$ TO $W_a/3,000$

PLATE 2

APPENDIX A: NOTATION

A	Surface area, ft ²
C	Coefficient
d	Water depth, ft
d/L	Relative depth
diam	Diameter, in.
g	Acceleration due to gravity, ft/sec ²
H	Wave height, ft
H/d	Relative wave height
H/L	Wave steepness
k	Shape coefficient
K	No-damage stability coefficient
ℓ_a	Characteristic length of armor unit, ft
L	Wavelength, ft
n	Number of armor unit layers
N	Number of armor units
P	Porosity of breakwater material, percent
R_N	Reynolds stability number
swl	Still-water level
S	Specific gravity of armor unit relative to water in which it is placed
t	Layer thickness of armor unit, ft
T	Wave period, sec
V	Volume, ft ³
W	Weight, lb
α	Angle of breakwater slope, measured from horizontal, deg
γ	Specific weight, pcf
ν	Kinematic viscosity, ft ² per sec

Subscripts

a	Refers to armor unit
D	Refers to damage
w	Refers to water in which structure is located
Δ	Refers to armor unit shape
1-4	Refers to various breakwater material sizes

END

FILMED

6-34

DTIC