

AD-A140 321

EXPERIMENTAL PRESSURE DISTRIBUTIONS ON AXISYMMETRIC
FOREBODIES AT MACH 3 A. (U) ROYAL AIRCRAFT
ESTABLISHMENT FARNBOROUGH (ENGLAND) L C WARD NOV 83

1/1

UNCLASSIFIED

RAE-TN-AERO-1985 DRIC-BR-90954

F/G 20/4

NL

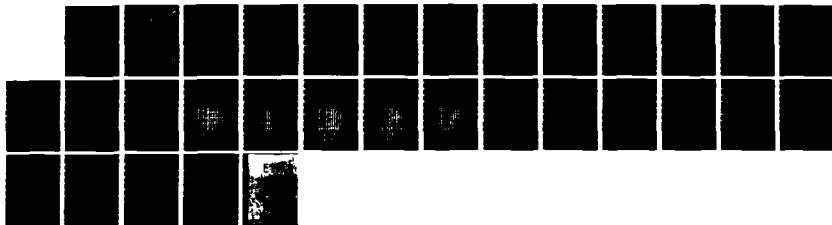

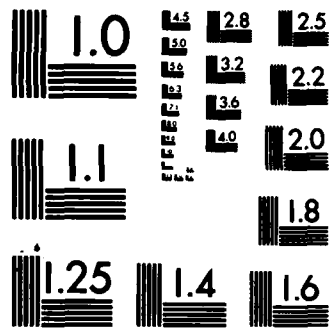

MICROCOPY RESOLUTION TEST CHART
 NATIONAL BUREAU OF STANDARDS-1963-A

TECH. MEMO
AERO 1985

BR90954.

TECH. MEMO
AERO 1985

3

ADA140321



ROYAL AIRCRAFT ESTABLISHMENT

EXPERIMENTAL PRESSURE DISTRIBUTIONS ON AXISYMMETRIC FOREBODIES
AT MACH 3 AND ANGLES OF ATTACK UP TO 17.5 DEGREES

by

L. C. Ward

November 1983

Copy available to DTIC does not
permit fully legible reproduction

DTIC FILE COPY

DTIC
ELECTE
APR 23 1984
S
A
E
D

Procurement Executive, Ministry of Defence
Farnborough, Hants

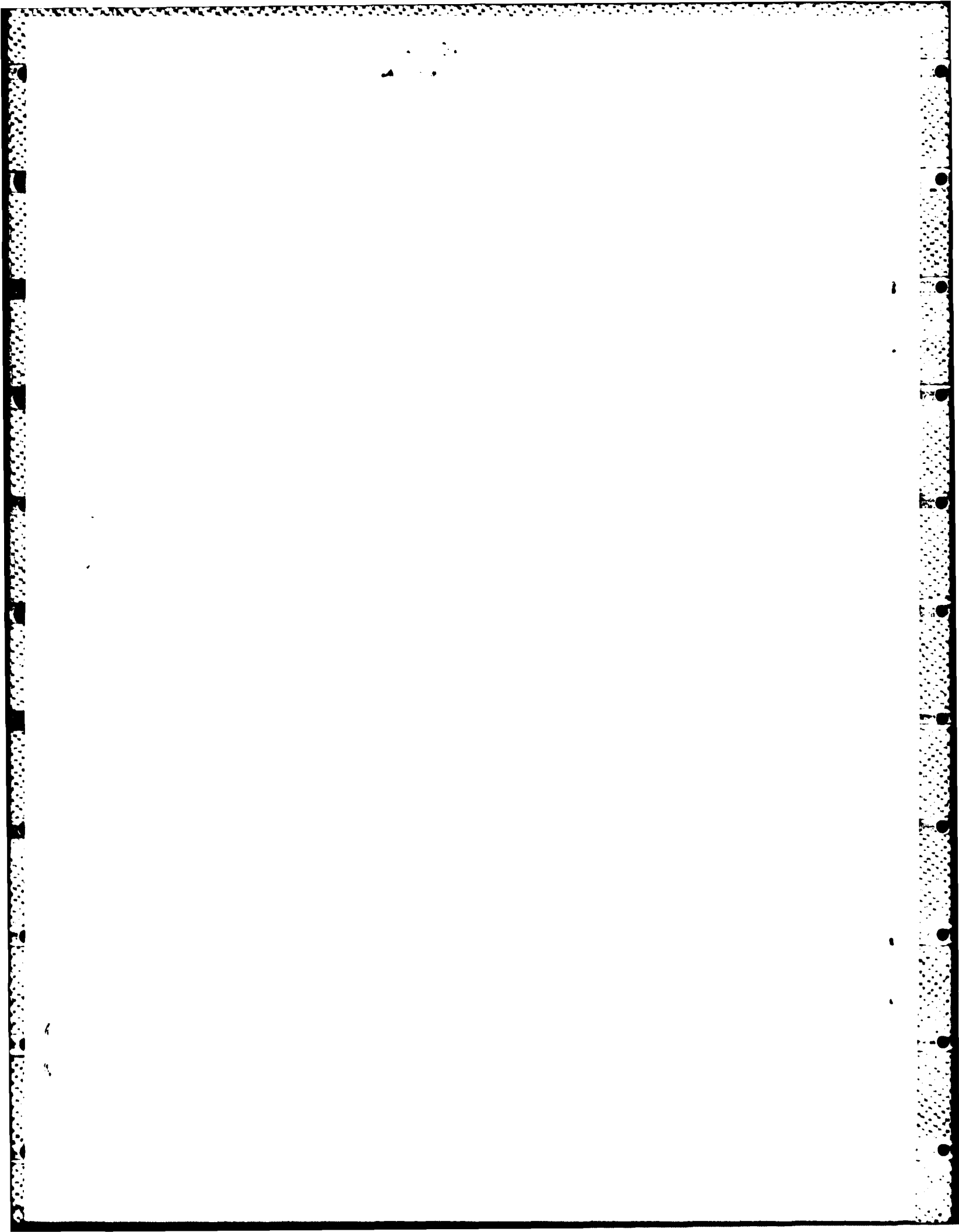

DISCLAIMER NOTICE

THIS DOCUMENT IS BEST QUALITY PRACTICABLE. THE COPY FURNISHED TO DTIC CONTAINED A SIGNIFICANT NUMBER OF PAGES WHICH DO NOT REPRODUCE LEGIBLY.

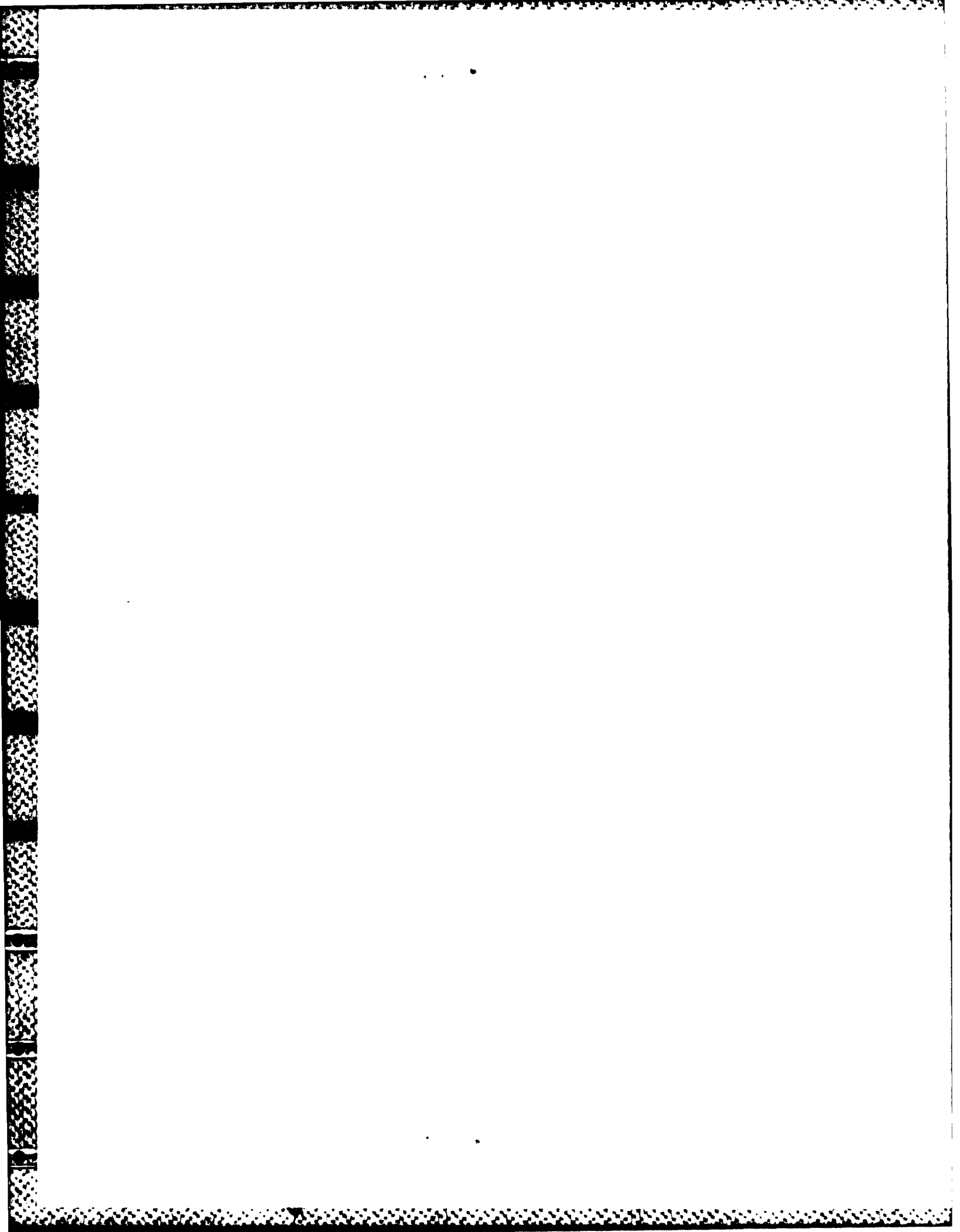

ROYAL AIRCRAFT ESTABLISHMENT

Technical Memorandum Aero 1985

Received for printing 17 November 1983

EXPERIMENTAL PRESSURE DISTRIBUTIONS ON AXISYMMETRIC FOREBODIES

AT MACH 3 AND ANGLES OF ATTACK UP TO 17.5 DEGREES

by

L. C. Ward

SUMMARY

→ Tabulations of experimental surface pressure distributions on both blunt and sharp axisymmetric forebodies are presented for a freestream Mach number of 3.0 and body angles of attack up to 17.5 degrees. The experimental details are described, but no analysis of the resultant data has been undertaken. ←

Copyright

©

Controller HMSO London
1983

LIST OF CONTENTS

	<u>Page</u>
1 INTRODUCTION	3
2 WIND TUNNEL, MODELS AND INSTRUMENTATION	3
3 PRESENTATION OF THE RESULTS	4
Tables 1 to 17	6
List of symbols	22
References	23
Illustrations	Figures 1&2
Report documentation page	inside back cover

Accession For	
NTIS GRA&I	<input checked="" type="checkbox"/>
DTIC TAB	<input type="checkbox"/>
Unannounced	<input type="checkbox"/>
Justification _____	
By _____	
Distribution/	
Availability Codes	
Dist	Avail and/or Special
A-1	23 CP



1 INTRODUCTION

Data are readily available relating to the surface pressure distributions and pressure drags of a variety of axisymmetric forebody profiles at both transonic and supersonic Mach numbers at zero angle of attack¹⁻⁶. This is not the case for non-zero angles of attack. Consequently it has been decided to publish surface pressure distributions obtained at a freestream Mach number of 3 for sixteen axisymmetric forebody profiles at angles of attack up to 17.5 degrees. A detailed analysis of the data for zero angle of attack extracted from the tests reported here has already been published⁷.

The forebody shapes investigated were spherically-blunted single and double cones, spherically-blunted tangent ogives, truncated cones and three-quarter power-law profiles. A description of the wind tunnel tests and tabulations of the measured pressure distributions are presented in this Memorandum. No analysis of the results has been undertaken.

2 WIND TUNNEL, MODELS AND INSTRUMENTATION

The models were tested during the period 1969 to 1971 in a 15 inch × 10 inch (0.38 metre × 0.25 metre) blowdown wind tunnel, the freestream Mach number at the model location being 3.00. The stagnation pressure was kept constant at $552 \times 10^3 \text{ N/m}^2$, giving a freestream Reynolds number per mm of 4.18×10^4 for all the models. No boundary layer transition fixing devices were used on any of the models.

The general arrangement of a model, adaptor and sting as mounted in the wind tunnel is shown in Fig 1, together with a cross-section through one model tube, the adaptor, and part of the sting. Seven tubes were accommodated within the sting, evenly spaced in roll, and with 'O' ring seals located at their ends at the sting-adaptor joint face.

By slackening the adaptor fixing screw, the adaptor and model could be rotated in steps of 51.43 degrees (one-seventh of a circle).

For each of the sixteen forebody profiles, two models were manufactured with differently positioned pressure tappings. The assigned model numbers and non-dimensional parameters of the forebody profiles are given in Table 1, the notation being defined in Fig 2 for the different types of forebody profile. As there are two definitions of the bluntness ratio in frequent use (*ie* $2r/D$ and d/D - see Fig 2), both ratios are tabulated. Drawings showing the actual model dimensions in millimeters are given with each table of results.

The pressure measuring holes were of diameter 0.5 mm, and were arranged in a spiral pattern around each model to minimise downstream interference effects between adjacent holes. All the tappings were inspected prior to the tunnel tests to ensure there were no burrs either inside the holes, or on the body surface around the holes.

The surface pressures were measured using a pressure transducer mounted in a pressure-stepping switch situated outside the wind tunnel. Pressure settling dwell times on the ports were determined from a number of initial 'shakedown' wind tunnel runs. Each port of the switch was 'O' ring sealed, with the transducer connected to vacuum between ports for the purpose of eliminating hysteresis effects. Known reference pressures were applied to the initial three ports of the switch, thus allowing the transducer to be

calibrated for each scan of the model pressures. The wind tunnel stagnation pressure was recorded for each pressure switch reading using a separate transducer mounted in a module complete with its own pressure calibration system.

The recording equipment consisted of a data-logger which switched the various transducer readings sequentially through an amplifier and analogue-to-digital converter. The resulting digital data were stored on paper tape ready for computer reduction to yield values of (p/p_0) .

The transducer excitation voltages and amplifier gain were set such that the overall pressure range of each transducer gave outputs in the order of 10000 counts. The observed repeatability of the readings derived from the reference pressures was approximately ± 2 counts. Applying this change to both transducers, the variation in (p/p_0) should be within ± 0.0001 to ± 0.0011 for the lowest to highest recorded values of p respectively.

The error in the setting of the model angle of attack (α) is not known, but is probably better than ± 0.1 degree. The location of the pressure holes in roll (ϕ) is probably within ± 0.5 degree.

3 PRESENTATION OF THE RESULTS

The surface pressures (p) have been divided by the freestream stagnation pressure (p_0), and are presented in Tables 2 to 17. Each table provides the complete results for one forebody profile (*i.e.* contains results from two nominally identical models as described in section 2), together with the forebody geometry and pressure hole locations. The forebody pressure drag coefficient at zero angle of attack ($C_{Dp(\alpha=0^\circ)}$) was obtained from integrations of the zero angle of attack pressure distribution as described in Ref 7. Model angles of attack (α) were varied from 0 to 17.5 degrees in 2.5 degree steps.

The models form two different groups: those with pressure tappings spaced 51.43 degrees apart in roll (model numbers 4 to 23), and those with pressure tappings spaced 45 degrees apart in roll (model numbers 24 to 35). For the first group, the model roll increment equals the spacing between the pressure tappings, and so there are only seven different values for the effective hole roll angle (ϕ) relative to the pitch plane, irrespective of the number of pressure tappings. Results for these models are shown in Tables 2 to 11. The differences in ϕ shown for models 4, 10 and 12 (in Tables 2, 5 and 6 respectively) are the result of mistakes made during model manufacture. Manufacturing errors were also responsible for the incorrect machining of models 10 and 11 (Table 5), the dimensions of neither model being quite as intended.

For the second group of models, the model roll increment does not equal the spacing between the pressure tappings, and so the number of values for the effective roll angle (ϕ) relative to the pitch plane of each forebody profile becomes 98 (two models, each with seven tappings and seven roll angles). Results for these models are shown in Tables 12 to 15, together with the variation in ϕ . Tables 16 and 17 give only zero angle of attack data since models 32 to 35 were not tested at any other angle of attack.

With the exception of models 32 to 35 (Tables 16 and 17), the zero angle of attack results are the average values of data taken at the seven model roll angles.

Table 1
SUMMARY OF BODY GEOMETRICAL PARAMETERS AND LIST OF TABLE NUMBERS

MODEL No.	f	2 π /D	d/D	θ_0°	θ_2°	R/D	TABLE No.	FOREBODY SHAPE
6 AND 7	0.163	0.133	0.390	70	/	/	3	SPHERICALLY-BLUNTED CONE
8 AND 9	0.441	0.198	0.280	45	/	/	4	" " "
12 AND 13	0.382	0.396	0.560	45	/	/	6	" " "
16 AND 17	3.125	0.198	0.200	7.5	/	/	8	" " "
20 AND 21	2.466	0.397	0.400	7.5	/	/	10	" " "
4 AND 5	0.182	0	0	70	/	/	2	SHARP CONE
10 AND 11	0.400	/	0.200	45	/	/	5	TRUNCATED CONE
14 AND 15	0.300	/	0.400	45	/	/	7	" " "
18 AND 19	3.038	/	0.200	7.5	/	/	9	" " "
22 AND 23	2.279	/	0.400	7.5	/	/	11	" " "
24 AND 25	3	0.098	0.100	10.95	6.94	/	12	SPHERICALLY-BLUNTED DOUBLE CONE
26 AND 27	2	0.121	0.125	14.36	11.01	/	13	" " "
28 AND 29	3	/	/	/	/	/	14	3/4 POWER LAW
30 AND 31	2	/	/	/	/	/	15	" " "
32 AND 33	2	0.279	0.300	/	/	5.214	16	SPHERICALLY-BLUNTED TANGENT OGIVE
34 AND 35	2	0.584	0.600	/	/	7.625	17	" " "

* RESULTS AT ZERO ANGLE OF ATTACK ONLY

Table 2
(p/p₀) FOR MODELS 4 AND 5

SHARP CONE - CYLINDER

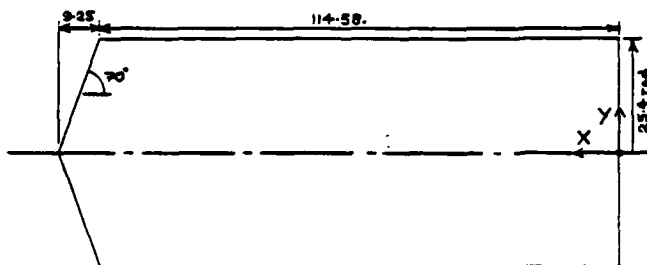

f	0.182
2r/D	0
d/D	0
g	70
g'	
R/D	

C_{Dp(α=σ)} = 1.4880

MODEL No.	4	5	4	5	4	5	4	5	4	5	4	5	4	5	
X	123.63	122.90	121.98	121.05	120.13	119.20	118.28	117.35	116.43	115.50	110.61	89.18	63.78	38.38	
Y	0	2.54	5.08	7.62	10.16	12.70	15.24	17.78	20.32	22.86	25.40	25.40	25.40	25.40	
α = 0°	0.3292	0.3242	0.3231	0.3180	0.3129	0.3070	0.3025	0.2928	0.2819	0.2591	0.0061	0.0200	0.0254	0.0261	
α = 2.5°	0.3255	0.3214	0.3149	0.3094	0.3040	0.3033	0.2986	0.2898	0.2751	0.2543	0.0048	0.0157	0.0229	0.0234	
Model No 4*	38.6	0.3248	0.3211	0.3183	0.3129	0.3095	0.2992	0.2964	0.2882	0.2793	0.2548	0.0050	0.0161	0.0227	0.0253
β = 0°, 51°, 103°, 103°, 154°, 154° (See Text)	90.0	0.3253	0.3212	0.3240	0.3158	0.3135	0.3073	0.3022	0.2880	0.2820	0.2537	0.0074	0.0205	0.0240	0.0253
	115.7	0.3245	0.3248	0.3228	0.3224	0.3129	0.3111	0.3013	0.2962	0.2815	0.2652	0.0072	0.0225	0.0271	0.0271
	141.4	0.3253	0.3240	0.3244	0.3207	0.3191	0.3101	0.3108	0.2954	0.2878	0.2626	0.0068	0.0231	0.0277	0.0273
	167.1	0.3284	0.3280	0.3239	0.3243	0.3173	0.3140	0.3051	0.3009	0.2859	0.2662	0.0077	0.0242	0.0274	0.0233
α = 5°	0.3202	0.3143	0.3097	0.3056	0.3002	0.2957	0.2888	0.2816	0.2681	0.2488	0.0039	0.0122	0.0202	0.0238	
*	38.6	0.3194	0.3135	0.3141	0.3057	0.3032	0.2941	0.2929	0.2839	0.2754	0.2467	0.0045	0.0129	0.0208	0.0239
β = 0°, 51°, 103°, 103°, 154°, 154°	64.3	0.3204	0.3161	0.3125	0.3091	0.3029	0.3000	0.2915	0.2864	0.2733	0.2557	0.0056	0.0189	0.0224	0.0230
	90.0	0.3209	0.3173	0.3157	0.3131	0.3116	0.2982	0.3012	0.2844	0.2815	0.2525	0.0076	0.0201	0.0241	0.0239
	115.7	0.3193	0.3242	0.3170	0.3179	0.3102	0.3103	0.3008	0.2983	0.2800	0.2640	0.0074	0.0259	0.0278	0.0234
	141.4	0.3206	0.3222	0.3241	0.3189	0.3193	0.3114	0.3114	0.2990	0.2920	0.2657	0.0085	0.0244	0.0282	0.0280
	167.1	0.3203	0.3244	0.3238	0.3233	0.3188	0.3186	0.3084	0.3044	0.2921	0.2714	0.0088	0.0296	0.0301	0.0292
α = 7.5°	0.3162	0.3103	0.3056	0.3006	0.2945	0.2895	0.2819	0.2753	0.2612	0.2433	0.0034	0.0098	0.0181	0.0223	
*	38.6	0.3158	0.3094	0.3101	0.3010	0.2983	0.2882	0.2878	0.2744	0.2685	0.2411	0.0039	0.0101	0.0191	0.0224
β = 0°, 51°, 103°, 103°, 154°, 154°	64.3	0.3158	0.3121	0.3083	0.3063	0.2981	0.2974	0.2870	0.2849	0.2669	0.2530	0.0048	0.0179	0.0210	0.0213
	90.0	0.3144	0.3127	0.3140	0.3082	0.3094	0.2959	0.2991	0.2826	0.2789	0.2512	0.0077	0.0197	0.0263	0.0224
	115.7	0.3145	0.3202	0.3144	0.3165	0.3079	0.3104	0.2985	0.2994	0.2790	0.2671	0.0076	0.0226	0.0283	0.0280
	141.4	0.3179	0.3199	0.3277	0.3179	0.3194	0.3177	0.3128	0.3008	0.2944	0.2684	0.0096	0.0306	0.0327	0.0290
	167.1	0.3164	0.3238	0.3244	0.3246	0.3207	0.3213	0.3120	0.3083	0.2963	0.2775	0.0099	0.0350	0.0337	0.0318
α = 10°	0.3127	0.3039	0.2987	0.2933	0.2870	0.2819	0.2747	0.2677	0.2545	0.2375	0.0031	0.0077	0.0154	0.0202	
*	38.6	0.3114	0.3036	0.3041	0.2941	0.2927	0.2814	0.2822	0.2670	0.2631	0.2352	0.0035	0.0078	0.0176	0.0201
β = 0°, 51°, 103°, 103°, 154°, 154°	64.3	0.3111	0.3084	0.3032	0.3029	0.2920	0.2934	0.2809	0.2805	0.2605	0.2505	0.0040	0.0175	0.0191	0.0193
	90.0	0.3112	0.3079	0.3120	0.3036	0.3067	0.2925	0.2966	0.2802	0.2775	0.2488	0.0078	0.0195	0.0262	0.0205
	115.7	0.3096	0.3183	0.3107	0.3142	0.3058	0.3083	0.2968	0.2993	0.2779	0.2695	0.0078	0.0333	0.0284	0.0285
	141.4	0.3126	0.3175	0.3219	0.3159	0.3192	0.3188	0.3148	0.3008	0.3008	0.2688	0.0109	0.0351	0.0353	0.0309
	167.1	0.3120	0.3232	0.3220	0.3242	0.3211	0.3218	0.3128	0.3128	0.3012	0.2830	0.0113	0.0411	0.0370	0.0351
α = 12.5°	0.3000	0.2956	0.2903	0.2852	0.2785	0.2744	0.2672	0.2611	0.2478	0.2313	0.0029	0.0063	0.0126	0.0176	
*	38.6	0.2986	0.2949	0.2960	0.2854	0.2845	0.2729	0.2744	0.2593	0.2553	0.2298	0.0031	0.0061	0.0162	0.0171
β = 0°, 51°, 103°, 103°, 154°, 154°	64.3	0.2988	0.2999	0.2950	0.2972	0.2841	0.2887	0.2740	0.2741	0.2545	0.2456	0.0035	0.0168	0.0174	0.0172
	90.0	0.2986	0.3009	0.3081	0.2981	0.3024	0.2876	0.2947	0.2755	0.2763	0.2448	0.0079	0.0198	0.0259	0.0187
	115.7	0.2974	0.3166	0.3077	0.3144	0.3041	0.3061	0.2953	0.2985	0.2783	0.2694	0.0081	0.0365	0.0286	0.0234
	141.4	0.3021	0.3159	0.3243	0.3152	0.3185	0.3091	0.3152	0.2992	0.3017	0.2684	0.0124	0.0395	0.0391	0.0320
	167.1	0.3024	0.3249	0.3234	0.3243	0.3194	0.3230	0.3169	0.3151	0.3048	0.2878	0.0129	0.0475	0.0408	0.0391
α = 15°	0.2879	0.2858	0.2808	0.2767	0.2698	0.2661	0.2594	0.2530	0.2413	0.2260	0.0029	0.0055	0.0105	0.0144	
*	38.6	0.2869	0.2847	0.2857	0.2759	0.2749	0.2639	0.2644	0.2518	0.2478	0.2242	0.0029	0.0052	0.0148	0.0140
β = 0°, 51°, 103°, 103°, 154°, 154°	64.3	0.2878	0.2896	0.2829	0.2884	0.2741	0.2813	0.2651	0.2652	0.2472	0.2411	0.0032	0.0190	0.0157	0.0155
	90.0	0.2847	0.2908	0.3061	0.2894	0.2958	0.2803	0.2809	0.2686	0.2751	0.2388	0.0081	0.0198	0.0255	0.0171
	115.7	0.2844	0.3096	0.3010	0.3119	0.3003	0.3071	0.2938	0.2983	0.2778	0.2680	0.0085	0.0406	0.0288	0.0309
	141.4	0.2876	0.3095	0.3214	0.3153	0.3205	0.3099	0.3151	0.3000	0.3052	0.2684	0.0142	0.0438	0.0426	0.0340
	167.1	0.2897	0.3202	0.3229	0.3279	0.3272	0.3227	0.3169	0.3158	0.3055	0.2918	0.0148	0.0541	0.0453	0.0441
α = 17.5°	0.2726	0.2726	0.2692	0.2655	0.2585	0.2561	0.2499	0.2441	0.2340	0.2202	0.0027	0.0048	0.0080	0.0116	
*	38.6	0.2713	0.2713	0.2728	0.2642	0.2647	0.2542	0.2549	0.2431	0.2390	0.2179	0.0027	0.0045	0.0132	0.0109
β = 0°, 51°, 103°, 103°, 154°, 154°	64.3	0.2720	0.2762	0.2638	0.2776	0.2630	0.2724	0.2549	0.2619	0.2389	0.2353	0.0031	0.0177	0.0138	0.0136
	90.0	0.2668	0.2772	0.2907	0.2780	0.2880	0.2708	0.2856	0.2607	0.2698	0.2320	0.0080	0.0206	0.0253	0.0157
	115.7	0.2673	0.3006	0.2909	0.3070	0.2924	0.3049	0.2877	0.2988	0.2717	0.2712	0.0082	0.0440	0.0292	0.0329
	141.4	0.2716	0.3018	0.3163	0.3109	0.3203	0.3095	0.3174	0.3015	0.3068	0.2729	0.0168	0.0478	0.0468	0.0369
	167.1	0.2757	0.3153	0.3175	0.3249	0.3238	0.3267	0.3207	0.3190	0.3072	0.2957	0.0183	0.0618	0.0511	0.0508

Table 3

(p/p₀) FOR MODELS 6 AND 7

SPHERICALLY-BLUNTED CONE-CYLINDER

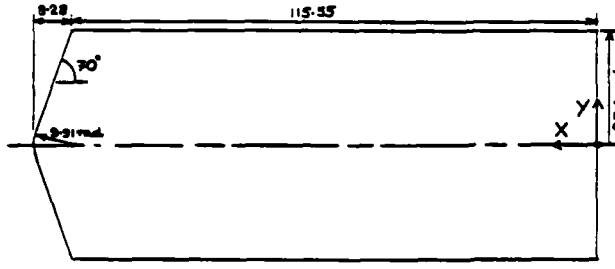

f	0.163
2πD	0.133
d/D	0.390
β	70
α	
R/D	

C_D(α=0°) = 1.4760

MODEL NO.	6	7	6	7	6	7	6	7	6	7	6	7		
X	123.78	123.49	122.94	122.02	121.09	120.17	119.24	118.32	117.39	116.47	115.576	90.15	64.75	39.35
Y	1.00	2.54	5.08	7.62	10.16	12.70	15.24	17.78	20.32	22.86	25.40	25.40	25.40	25.40

α = 0° 0.3250 0.3245 0.3187 0.3163 0.3100 0.3065 0.2995 0.2914 0.2782 0.2608 0.0062 0.0199 0.0252 0.0260

α	β	12.9°	38.6°	64.3°	90.0°	115.7°	141.4°	167.1°							
α = 2.5°	β = 12.9°	0.3199	0.3205	0.3153	0.3129	0.3051	0.3024	0.2915	0.2888	0.2717	0.2575	0.0047	0.0153	0.0221	0.0247
	β = 38.6°	0.3203	0.3208	0.3149	0.3128	0.3037	0.3013	0.2899	0.2857	0.2720	0.2547	0.0060	0.0160	0.0236	0.0248
	β = 64.3°	0.3257	0.3211	0.3156	0.3135	0.3042	0.3020	0.2896	0.2870	0.2765	0.2604	0.0057	0.0196	0.0279	0.0241
	β = 90.0°	0.3224	0.3219	0.3157	0.3123	0.3073	0.3013	0.2949	0.2860	0.2741	0.2568	0.0070	0.0201	0.0263	0.0251
	β = 115.7°	0.3231	0.3236	0.3174	0.3200	0.3141	0.3114	0.3013	0.2925	0.2834	0.2689	0.0075	0.0220	0.0267	0.0268
α = 5°	β = 12.9°	0.3179	0.3145	0.3116	0.3082	0.2920	0.2942	0.2854	0.2795	0.2657	0.2511	0.0084	0.0121	0.0198	0.0234
	β = 38.6°	0.3190	0.3148	0.3118	0.3082	0.3001	0.2959	0.2874	0.2807	0.2664	0.2488	0.0052	0.0128	0.0215	0.0237
	β = 64.3°	0.3194	0.3191	0.3127	0.3104	0.3023	0.2986	0.2904	0.2879	0.2733	0.2585	0.0058	0.0190	0.0216	0.0230
	β = 90.0°	0.3210	0.3188	0.3133	0.3097	0.3051	0.2996	0.2933	0.2850	0.2729	0.2552	0.0070	0.0196	0.0265	0.0236
	β = 115.7°	0.3211	0.3235	0.3163	0.3158	0.3133	0.3129	0.3008	0.2999	0.2858	0.2673	0.0075	0.0255	0.0275	0.0277
α = 7.5°	β = 12.9°	0.3147	0.3093	0.3028	0.3013	0.2879	0.2879	0.2729	0.2729	0.2590	0.2459	0.0082	0.0285	0.0177	0.0217
	β = 38.6°	0.3160	0.3104	0.3077	0.3001	0.2948	0.2888	0.2817	0.2749	0.2612	0.2428	0.0044	0.0102	0.0195	0.0221
	β = 64.3°	0.3168	0.3166	0.3091	0.3074	0.2983	0.2964	0.2859	0.2844	0.2688	0.2541	0.0054	0.0184	0.0204	0.0215
	β = 90.0°	0.3201	0.3166	0.3103	0.3077	0.3035	0.2973	0.2921	0.2837	0.2717	0.2541	0.0070	0.0193	0.0246	0.0217
	β = 115.7°	0.3186	0.3237	0.3154	0.3148	0.3113	0.3121	0.2990	0.2999	0.2808	0.2685	0.0079	0.0289	0.0283	0.0285
α = 10°	β = 12.9°	0.3082	0.3014	0.2951	0.2937	0.2844	0.2807	0.2714	0.2663	0.2526	0.2394	0.0031	0.0076	0.0147	0.0194
	β = 38.6°	0.3097	0.3031	0.3003	0.2926	0.2867	0.2812	0.2745	0.2655	0.2546	0.2368	0.0034	0.0081	0.0176	0.0202
	β = 64.3°	0.3121	0.3106	0.3022	0.3020	0.2921	0.2921	0.2807	0.2788	0.2639	0.2481	0.0030	0.0180	0.0191	0.0196
	β = 90.0°	0.3159	0.3127	0.3096	0.3060	0.3011	0.2932	0.2894	0.2804	0.2708	0.2522	0.0030	0.0191	0.0265	0.0197
	β = 115.7°	0.3176	0.3215	0.3133	0.3128	0.3096	0.3118	0.2971	0.2989	0.2795	0.2680	0.0081	0.0328	0.0287	0.0294
α = 12.5°	β = 12.9°	0.2990	0.2924	0.2867	0.2847	0.2772	0.2725	0.2637	0.2585	0.2458	0.2325	0.0029	0.0061	0.0119	0.0168
	β = 38.6°	0.3002	0.2927	0.2912	0.2834	0.2786	0.2727	0.2631	0.2573	0.2482	0.2305	0.0031	0.0066	0.0159	0.0177
	β = 64.3°	0.3034	0.3023	0.2940	0.2941	0.2851	0.2863	0.2744	0.2724	0.2578	0.2434	0.0047	0.0180	0.0177	0.0178
	β = 90.0°	0.3081	0.3046	0.3036	0.2961	0.2964	0.2870	0.2860	0.2738	0.2687	0.2476	0.0020	0.0191	0.0216	0.0176
	β = 115.7°	0.3095	0.3118	0.3085	0.3120	0.3084	0.3101	0.2963	0.2972	0.2780	0.2675	0.0083	0.0371	0.0290	0.0306
α = 15°	β = 12.9°	0.2895	0.2816	0.2775	0.2748	0.2681	0.2640	0.2554	0.2506	0.2390	0.2267	0.0028	0.0054	0.0097	0.0139
	β = 38.6°	0.2913	0.2817	0.2804	0.2730	0.2686	0.2634	0.2538	0.2494	0.2417	0.2245	0.0029	0.0056	0.0143	0.0142
	β = 64.3°	0.2937	0.2931	0.2851	0.2850	0.2757	0.2727	0.2645	0.2659	0.2516	0.2385	0.0043	0.0179	0.0163	0.0161
	β = 90.0°	0.2991	0.2947	0.2948	0.2864	0.2886	0.2790	0.2790	0.2696	0.2639	0.2426	0.0069	0.0204	0.0251	0.0160
	β = 115.7°	0.3020	0.3052	0.3021	0.3034	0.3040	0.3103	0.2944	0.2977	0.2796	0.2681	0.0090	0.0409	0.0293	0.0322
α = 17.5°	β = 12.9°	0.2744	0.2665	0.2653	0.2632	0.2570	0.2534	0.2461	0.2410	0.2322	0.2202	0.0027	0.0048	0.0081	0.0107
	β = 38.6°	0.2772	0.2668	0.2676	0.2609	0.2580	0.2530	0.2425	0.2408	0.2339	0.2218	0.0023	0.0049	0.0128	0.0115
	β = 64.3°	0.2827	0.2810	0.2736	0.2737	0.2666	0.2669	0.2571	0.2573	0.2435	0.2318	0.0041	0.0185	0.0146	0.0145
	β = 90.0°	0.2870	0.2816	0.2831	0.2754	0.2754	0.2680	0.2622	0.2617	0.2582	0.2466	0.0030	0.0204	0.0251	0.0144
	β = 115.7°	0.2924	0.2969	0.2944	0.3014	0.2974	0.3076	0.2900	0.2967	0.2765	0.2705	0.0095	0.0440	0.0290	0.0344
β = 141.4°	0.2941	0.3019	0.3140	0.3126	0.3180	0.3060	0.3128	0.3028	0.2979	0.2765	0.0134	0.0461	0.0464	0.0353	
β = 167.1°	0.3005	0.3073	0.3176	0.3229	0.3236	0.3251	0.3209	0.3187	0.3102	0.2996	0.0177	0.0602	0.0504	0.0509	

Table 4
(p/p₀) FOR MODELS 8 AND 9

SPHERICALLY-BLUNTED CONE-CYLINDER

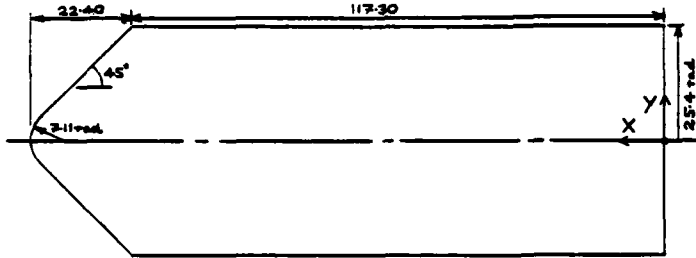

f	0.441
2r/b	0.198
d/D	0.280
β	45
θ	
R/D	

C_{0p(α=0°)} = 1.1520

MODEL NO.	8	9	8	9	8	9	8	9	8	9	8	9	8	9
X	139.70	139.23	137.62	135.08	132.54	130.00	127.46	124.92	122.38	119.84	113.33	91.90	66.50	41.10
Y	0	2.54	5.08	7.62	10.16	12.70	15.24	17.78	20.32	22.86	25.40	25.40	25.40	25.40

α = 0°	0.3307	0.2962	0.1963	0.2143	0.2170	0.2231	0.2226	0.2279	0.2208	0.2263	0.0180	0.0210	0.0241	0.0258
--------	--------	--------	--------	--------	--------	--------	--------	--------	--------	--------	--------	--------	--------	--------

α	β	12.9°	38.6°	64.3°	90.0°	115.7°	141.4°	167.1°							
α = 2.5°	β = 12.9°	0.3267	0.2918	0.1740	0.1989	0.2014	0.2035	0.2077	0.2105	0.2092	0.2176	0.0166	0.0287	0.0214	0.0248
	β = 38.6°	0.3314	0.2905	0.1792	0.2004	0.2048	0.2111	0.2110	0.2137	0.2086	0.2078	0.0169	0.0277	0.0224	0.0241
	β = 64.3°	0.3295	0.2875	0.1864	0.2030	0.2101	0.2133	0.2176	0.2190	0.2183	0.2163	0.0179	0.0200	0.0224	0.0238
	β = 90.0°	0.3288	0.2874	0.1997	0.2144	0.2161	0.2231	0.2247	0.2255	0.2194	0.2295	0.0177	0.0312	0.0251	0.0258
	β = 115.7°	0.3297	0.2863	0.2219	0.2233	0.2292	0.2350	0.2263	0.2304	0.0181	0.0221	0.0230			
α = 5°	β = 12.9°	0.3224	0.2490	0.1604	0.1801	0.1857	0.1935	0.1915	0.1947	0.1934	0.1896	0.0154	0.0154	0.0193	0.0238
	β = 38.6°	0.3259	0.2814	0.1674	0.1922	0.1938	0.1981	0.1993	0.2002	0.1973	0.2044	0.0160	0.0166	0.0208	0.0223
	β = 64.3°	0.3243	0.2785	0.1796	0.1964	0.2006	0.2130	0.2094	0.2136	0.2097	0.2213	0.0120	0.0184	0.0205	0.0219
	β = 90.0°	0.3246	0.2785	0.2020	0.2157	0.2165	0.2219	0.2237	0.2246	0.2199	0.2281	0.0136	0.0211	0.0251	0.0266
	β = 115.7°	0.3254	0.2773	0.2143	0.2244	0.2280	0.2356	0.2423	0.2317	0.2413	0.0183	0.0235	0.0260		
α = 7.5°	β = 12.9°	0.3209	0.2430	0.1466	0.1653	0.1702	0.1778	0.1737	0.1828	0.1732	0.1755	0.0142	0.0285	0.0171	0.0223
	β = 38.6°	0.3213	0.2749	0.1577	0.1829	0.1799	0.1862	0.1857	0.1874	0.1876	0.1895	0.0149	0.0144	0.0178	0.0200
	β = 64.3°	0.3216	0.2720	0.1728	0.1832	0.1921	0.2104	0.1990	0.2063	0.1990	0.2104	0.0158	0.0167	0.0188	0.0195
	β = 90.0°	0.3228	0.2924	0.2019	0.2213	0.2168	0.2190	0.2210	0.2210	0.2165	0.2233	0.0132	0.0276	0.0249	0.0230
	β = 115.7°	0.3237	0.2927	0.2277	0.2313	0.2321	0.2364	0.2444	0.2307	0.2390	0.0181	0.0250	0.0266		
α = 10°	β = 12.9°	0.3212	0.2359	0.1438	0.1520	0.1641	0.1623	0.1632	0.1624	0.1620	0.0129	0.0248	0.0151	0.0209	
	β = 38.6°	0.3211	0.2635	0.1482	0.1699	0.1639	0.1741	0.1731	0.1734	0.1748	0.0132	0.0137	0.0171	0.0170	
	β = 64.3°	0.3217	0.2617	0.1642	0.1723	0.1822	0.1986	0.1863	0.1944	0.1853	0.1928	0.0145	0.0157	0.0171	0.0168
	β = 90.0°	0.3223	0.2937	0.2083	0.2212	0.2138	0.2144	0.2147	0.2116	0.2166	0.0168	0.0208	0.0245	0.0213	
	β = 115.7°	0.3237	0.2926	0.2366	0.2348	0.2392	0.2420	0.2336	0.0181	0.0268	0.0271				
α = 12.5°	β = 12.9°	0.3136	0.2332	0.1190	0.1330	0.1366	0.1510	0.1473	0.1525	0.1486	0.1439	0.0115	0.0102	0.0137	0.0197
	β = 38.6°	0.3130	0.2562	0.1355	0.1530	0.1490	0.1579	0.1583	0.1587	0.1579	0.1621	0.0125	0.0114	0.0138	0.0136
	β = 64.3°	0.3158	0.2501	0.1574	0.1676	0.1699	0.1846	0.1731	0.1802	0.1703	0.1832	0.0135	0.0141	0.0152	0.0139
	β = 90.0°	0.3150	0.2981	0.2121	0.2253	0.2037	0.2070	0.2088	0.2058	0.2041	0.2069	0.0161	0.0208	0.0243	0.0198
	β = 115.7°	0.3133	0.2981	0.2361	0.2352	0.2304	0.2304	0.2305	0.2227	0.2285	0.0181	0.0286	0.0275		
α = 15°	β = 12.9°	0.3091	0.2227	0.1061	0.1201	0.1226	0.1344	0.1343	0.1388	0.1348	0.1408	0.0106	0.0248	0.0132	0.0185
	β = 38.6°	0.3092	0.2426	0.1234	0.1457	0.1361	0.1427	0.1429	0.1444	0.1454	0.1473	0.0114	0.0101	0.0120	0.0105
	β = 64.3°	0.3123	0.2402	0.1513	0.1570	0.1586	0.1710	0.1585	0.1658	0.1561	0.1684	0.0124	0.0131	0.0133	0.0117
	β = 90.0°	0.3082	0.2934	0.2101	0.2221	0.2013	0.1999	0.2037	0.1983	0.1968	0.1968	0.0161	0.0209	0.0238	0.0184
	β = 115.7°	0.3093	0.2405	0.2344	0.2335	0.2263	0.2369	0.2192	0.2257	0.0181	0.0321	0.0279			
α = 17.5°	β = 12.9°	0.2867	0.2048	0.0938	0.1081	0.1099	0.1231	0.1201	0.1235	0.1207	0.1256	0.0094	0.0234	0.0126	0.0177
	β = 38.6°	0.2963	0.2284	0.1136	0.1352	0.1235	0.1265	0.1237	0.1302	0.1305	0.1305	0.0101	0.0092	0.0100	0.0077
	β = 64.3°	0.2997	0.2246	0.1433	0.1443	0.1453	0.1547	0.1422	0.1498	0.1423	0.1423	0.0113	0.0120	0.0112	0.0094
	β = 90.0°	0.2945	0.2833	0.2063	0.2155	0.1918	0.1916	0.1953	0.1876	0.1876	0.1812	0.0153	0.0204	0.0235	0.0175
	β = 115.7°	0.2968	0.2408	0.2301	0.2305	0.2305	0.2218	0.2329	0.2144	0.2218	0.0183	0.0343	0.0283		

Table 5

(p/p₀) FOR MODELS 10 AND 11

TRUNCATED CONE-CYLINDER

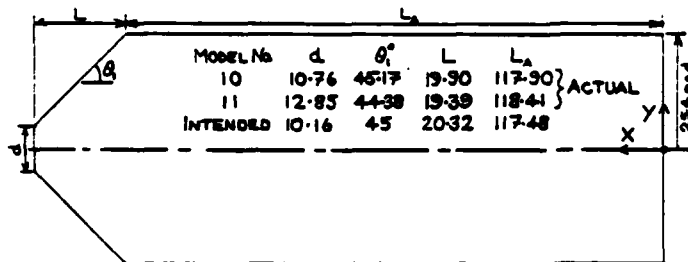

INTENDED

f	0.400
2r/D	
d/D	0.200
theta	45
theta_a	
R/D	

C_D(alpha=0) = 1.0520

Model No.	10	11	10	11	10	11	10	11	10	11	10	11	10	11
X	137.80	137.80	137.80	135.26	132.72	130.18	127.64	125.10	122.56	120.02	115.48	112.08	108.68	105.28
Y	0	2.54	5.08	7.62	10.16	12.70	15.24	17.78	20.32	22.86	25.40	25.40	25.40	25.40

alpha = 0°

	0.3322	0.3280	0.2644	0.1078	0.2134	0.2170	0.2209	0.2190	0.2260	0.2178	0.0206	0.0209	0.0242	0.0251
--	--------	--------	--------	--------	--------	--------	--------	--------	--------	--------	--------	--------	--------	--------

alpha	beta	Model No	10	11	10	11	10	11	10	11	10	11	10	11				
2.5°	*	12.9°	0.3302	0.3229	0.2549	0.0816	0.1943	0.2005	0.2094	0.2022	0.2084	0.2019	0.0190	0.0173	0.0219	0.0252		
		39.6°	0.3315	0.3243	0.2540	0.0984	0.1958	0.2055	0.2105	0.2060	0.2124	0.2059	0.0196	0.0185	0.0212	0.0236		
		64.3°	0.3314	0.3259	0.2593	0.1141	0.2044	0.2074	0.2188	0.2106	0.2187	0.2127	0.0202	0.0191	0.0235	0.0273		
		90.0°	0.3303	0.3267	0.2445	0.1194	0.2110	0.2139	0.2221	0.2197	0.2251	0.2180	0.0208	0.0219	0.0236	0.0251		
		115.7°	0.3280	0.3267	0.2490	0.1455	0.2225	0.2232	0.2316	0.2253	0.2358	0.2253	0.0213	0.0218	0.0240	0.0249		
		141.4°	0.3301	0.3315	0.2698	0.1437	0.2292	0.2292	0.2370	0.2321	0.2374	0.2297	0.0211	0.0244	0.0240	0.0246		
		167.1°	0.3297	0.3307	0.2697	0.1503	0.2334	0.2331	0.2421	0.2357	0.2408	0.2334	0.0214	0.0232	0.0232	0.0263		
		5°	*	12.9°	0.3250	0.3176	0.2491	0.0821	0.1796	0.1820	0.1938	0.1854	0.1924	0.1865	0.0174	0.0157	0.0195	0.0234
				39.6°	0.3291	0.3172	0.2492	0.0939	0.1793	0.1820	0.1945	0.1936	0.1978	0.1966	0.0180	0.0168	0.0187	0.0215
				64.3°	0.3250	0.3219	0.2534	0.0980	0.1801	0.1837	0.2128	0.2005	0.2130	0.2078	0.0194	0.0174	0.0221	0.0204
90.0°	0.3279			0.3263	0.2609	0.1394	0.2090	0.2168	0.2166	0.2200	0.2203	0.2192	0.0201	0.0227	0.0225	0.0244		
115.7°	0.3250			0.3243	0.2495	0.1444	0.2224	0.2231	0.2404	0.2379	0.2404	0.2256	0.0206	0.0229	0.0237	0.0244		
141.4°	0.3273			0.3243	0.2352	0.1534	0.2405	0.2427	0.2448	0.2447	0.2441	0.2399	0.0207	0.0239	0.0281	0.0283		
167.1°	0.3254			0.3252	0.2393	0.2001	0.2513	0.2443	0.2550	0.2471	0.2524	0.2428	0.0209	0.0234	0.0303	0.0302		
7.5°	*			12.9°	0.3231	0.3163	0.2453	0.0724	0.1620	0.1627	0.1732	0.1690	0.1790	0.1717	0.0158	0.0141	0.0170	0.0219
				39.6°	0.3272	0.3168	0.2457	0.0799	0.1648	0.1757	0.1810	0.1844	0.1856	0.0164	0.0150	0.0161	0.0189	
				64.3°	0.3229	0.3210	0.2508	0.0913	0.1737	0.1842	0.2047	0.1887	0.2058	0.1916	0.0187	0.0156	0.0206	0.0178
		90.0°	0.3258	0.3241	0.2407	0.1674	0.2049	0.2168	0.2135	0.2194	0.2139	0.2155	0.0190	0.0223	0.0214	0.0233		
		115.7°	0.3233	0.3225	0.2399	0.1880	0.2404	0.2287	0.2445	0.2238	0.2426	0.2237	0.0194	0.0238	0.0293	0.0240		
		141.4°	0.3240	0.3245	0.2397	0.2423	0.2504	0.2540	0.2505	0.2535	0.2479	0.2447	0.0198	0.0324	0.0301	0.0300		
		167.1°	0.3243	0.3230	0.2308	0.2445	0.2468	0.2584	0.2444	0.2557	0.2400	0.2484	0.0206	0.0317	0.0339	0.0302		
		10°	*	12.9°	0.3248	0.3148	0.2341	0.0654	0.1430	0.1442	0.1572	0.1487	0.1449	0.1584	0.0144	0.0143	0.0147	0.0202
				39.6°	0.3249	0.3154	0.2343	0.0733	0.1484	0.1614	0.1638	0.1679	0.1678	0.1805	0.0143	0.0133	0.0140	0.0158
				64.3°	0.3252	0.3210	0.2408	0.0913	0.1899	0.1916	0.1937	0.1749	0.1948	0.1751	0.0166	0.0139	0.0140	0.0150
90.0°	0.3286			0.3239	0.2355	0.1854	0.2004	0.2130	0.2085	0.2172	0.2052	0.2112	0.0175	0.0242	0.0203	0.0220		
115.7°	0.3241			0.3274	0.2327	0.2024	0.2488	0.2284	0.2473	0.2251	0.2445	0.2193	0.0190	0.0253	0.0309	0.0234		
141.4°	0.3283			0.3281	0.2321	0.2455	0.2576	0.2420	0.2591	0.2400	0.2499	0.2484	0.0198	0.0334	0.0319	0.0326		
167.1°	0.3241			0.3283	0.2342	0.2448	0.2502	0.2485	0.2572	0.2424	0.2465	0.2514	0.0213	0.0373	0.0355	0.0329		
12.5°	*			12.9°	0.3194	0.3081	0.2273	0.0548	0.1278	0.1294	0.1424	0.1338	0.1492	0.1403	0.0129	0.0140	0.0133	0.0192
				39.6°	0.3203	0.3103	0.2291	0.0631	0.1340	0.1488	0.1445	0.1527	0.1527	0.1563	0.0130	0.0122	0.0128	0.0124
				64.3°	0.3194	0.3141	0.2452	0.0884	0.1818	0.1588	0.1829	0.1611	0.1841	0.1618	0.0154	0.0124	0.0181	0.0121
		90.0°	0.3233	0.3187	0.2514	0.2030	0.1951	0.2124	0.1957	0.2140	0.1944	0.2073	0.0161	0.0255	0.0191	0.0211		
		115.7°	0.3202	0.3224	0.2303	0.2165	0.2352	0.2240	0.2483	0.2229	0.2412	0.2161	0.0186	0.0270	0.0323	0.0222		
		141.4°	0.3229	0.3247	0.2391	0.2817	0.2440	0.2679	0.2574	0.2657	0.2514	0.2591	0.0194	0.0424	0.0338	0.0357		
		167.1°	0.3212	0.3245	0.2304	0.2829	0.2319	0.2574	0.2622	0.2688	0.2575	0.2537	0.0224	0.0437	0.0421	0.0365		
		15°	*	12.9°	0.3175	0.3041	0.2183	0.0474	0.1121	0.1194	0.1284	0.1207	0.1345	0.1246	0.0115	0.0138	0.0129	0.0192
				39.6°	0.3184	0.3071	0.2228	0.0574	0.1214	0.1366	0.1322	0.1390	0.1364	0.1437	0.0118	0.0110	0.0121	0.0094
				64.3°	0.3178	0.3077	0.2345	0.0828	0.1732	0.1448	0.1731	0.1475	0.1726	0.1475	0.0138	0.0115	0.0167	0.0094
90.0°	0.3194			0.3167	0.2445	0.2128	0.1888	0.2083	0.1842	0.2094	0.1840	0.1994	0.0144	0.0266	0.0178	0.0206		
115.7°	0.3183			0.3199	0.2374	0.2248	0.2572	0.2215	0.2477	0.2149	0.2421	0.2204	0.0184	0.0289	0.0339	0.0224		
141.4°	0.3193			0.3242	0.2304	0.2948	0.2680	0.2730	0.2895	0.2685	0.2503	0.2573	0.0197	0.0459	0.0361	0.0393		
167.1°	0.3183			0.3247	0.2354	0.2961	0.2633	0.2815	0.2891	0.2727	0.2591	0.2574	0.0231	0.0487	0.0472	0.0429		
17.5°	*			12.9°	0.3084	0.2972	0.2084	0.0419	0.0974	0.1087	0.1138	0.1077	0.1195	0.1106	0.0103	0.0130	0.0126	0.0199
				39.6°	0.3093	0.2981	0.2121	0.0548	0.1087	0.1245	0.1164	0.1269	0.1197	0.1291	0.0101	0.0098	0.0118	0.0068
				64.3°	0.3098	0.3017	0.2229	0.0710	0.1461	0.1343	0.1597	0.1340	0.1592	0.1329	0.0123	0.0104	0.0150	0.0073
		90.0°	0.3112	0.3083	0.2427	0.2175	0.1814	0.2003	0.1744	0.2005	0.1708	0.1905	0.0132	0.0281	0.0167	0.0202		
		115.7°	0.3104	0.3163	0.2358	0.2291	0.2572	0.2174	0.2470	0.2112	0.2473	0.2208	0.0184	0.0299	0.0342	0.0223		
		141.4°	0.3110	0.3187	0.2307	0.3032	0.2709	0.2811	0.2405	0.2833	0.2499	0.2537	0.0203	0.0543	0.0389	0.0441		
		167.1°	0.3121	0.3219	0.2306	0.3060	0.3107	0.2825	0.2975	0.2789	0.2836	0.2601	0.0249	0.0543	0.0532	0.0441		

Table 6

(p/p₀) FOR MODELS 12 AND 13

SPHERICALLY-BLUNTED CONE-CYLINDER

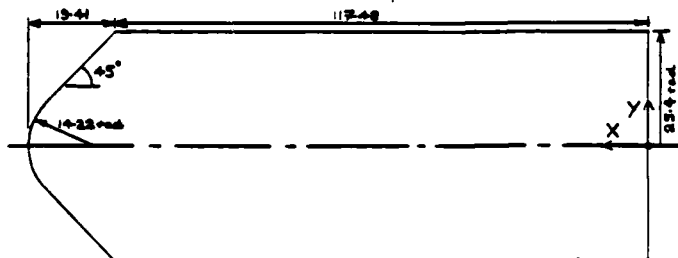

f	0.382
2r/D	0.396
d/D	0.560
β	4.5
β'	
R/D	

C_{Dp}(α=0°) = 1.0920

Model No.	12	13	12	13	12	13	12	13	12	13	12	13		
X	4.89	13.65	135.94	134.67	132.72	130.18	127.64	125.10	122.56	120.02	112.30	92.08	66.68	41.28
Y	0.40	2.54	5.08	7.62	10.16	12.70	15.24	17.78	20.32	22.86	25.40	25.40	25.40	25.40

α = 0°	0.3309	0.3215	0.2894	0.2355	0.1892	0.2077	0.2137	0.2186	0.2201	0.2192	0.0206	0.0199	0.0232	0.0250
--------	--------	--------	--------	--------	--------	--------	--------	--------	--------	--------	--------	--------	--------	--------

Model No. 12 β = 18°, 34°, 63°, 83°, 121°, 136°, 172° (See Text)	β*	α = 0°													
		†	†	†	†	†	†	†	†	†	†	†	†	†	
Model No. 12 β = 21°, 31°, 72°, 83°, 124°, 134°, 173° (See Text)	12.5°	0.3262	0.3141	0.2786	0.2236	0.1700	0.1884	0.1971	0.2028	0.2080	0.2089	0.0187	0.0174	0.0214	0.0248
	38.6°	0.3250	0.3143	0.2768	0.2235	0.1731	0.1945	0.1977	0.2066	0.2088	0.2076	0.0188	0.0181	0.0212	0.0234
	64.3°	0.3257	0.3179	0.2837	0.2280	0.1829	0.1983	0.1998	0.2137	0.2185	0.2148	0.0204	0.0187	0.0221	0.0226
	90.0°	0.3294	0.3209	0.2888	0.2383	0.1894	0.2079	0.2092	0.2168	0.2160	0.2168	0.0201	0.0205	0.0224	0.0248
	115.7°	0.3297	0.3210	0.2929	0.2413	0.1991	0.2133	0.2243	0.2261	0.2295	0.2276		0.0211	0.0248	0.0250
	141.4°	0.3307	0.3248	0.2947	0.2477	0.2044	0.2279	0.2245	0.2277	0.2334	0.2302	0.0215	0.0226	0.0257	0.0263
167.1°	0.3264	0.3233	0.2874	0.2482	0.2093	0.2231	0.2336	0.2348	0.2351	0.2342	0.0217	0.0224	0.0260	0.0263	
Model No. 12 β = 21°, 31°, 72°, 83°, 124°, 134°, 173° (See Text)	12.5°	0.3213	0.3075	0.2677	0.2148	0.1554	0.1713	0.1802	0.1802	0.1817	0.1887	0.0169	0.0156	0.0187	0.0229
	38.6°	0.3208	0.3098	0.2689	0.2148	0.1586	0.1728	0.1802	0.1932	0.1885	0.1963	0.0170	0.0167	0.0189	0.0213
	64.3°	0.3212	0.3122	0.2728	0.2219	0.1720	0.1898	0.1993	0.2051	0.2128	0.2065	0.0196	0.0177	0.0208	0.0206
	90.0°	0.3287	0.3189	0.2828	0.2353	0.1879	0.2102	0.2061	0.2180	0.2125	0.2155	0.0198	0.0206	0.0224	0.0238
	115.7°	0.3243	0.3195	0.2926	0.2444	0.2057	0.2239	0.2347	0.2310	0.2424	0.2323		0.0221	0.0264	0.0248
	141.4°	0.3242	0.3250	0.2985	0.2595	0.2196	0.2395	0.2359	0.2412	0.2406	0.2395	0.0214	0.0237	0.0285	0.0278
167.1°	0.3236	0.3236	0.2915	0.2626	0.2300	0.2443	0.2505	0.2491	0.2494	0.2430	0.0224	0.0262	0.0296	0.0283	
Model No. 12 β = 21°, 31°, 72°, 83°, 124°, 134°, 173° (See Text)	12.5°	0.3196	0.3047	0.2580	0.2009	0.1397	0.1525	0.1632	0.1614	0.1737	0.1726	0.0152	0.0144	0.0173	0.0209
	38.6°	0.3205	0.3055	0.2599	0.2093	0.1449	0.1659	0.1637	0.1801	0.1761	0.1833	0.0152	0.0152	0.0165	0.0190
	64.3°	0.3196	0.3106	0.2726	0.2164	0.1733	0.1813	0.1963	0.1949	0.2056	0.1957	0.0183	0.0158	0.0195	0.0181
	90.0°	0.3221	0.3117	0.2803	0.2342	0.1891	0.2117	0.2026	0.2170	0.2074	0.2128	0.0189	0.0209	0.0215	0.0228
	115.7°	0.3203	0.3174	0.2934	0.2489	0.2213	0.2280	0.2412	0.2323	0.2392	0.2266		0.0234	0.0280	0.0265
	141.4°	0.3212	0.3251	0.3028	0.2705	0.2344	0.2573	0.2440	0.2503	0.2420	0.2416	0.0213	0.0295	0.0302	0.0297
167.1°	0.3214	0.3226	0.3092	0.2767	0.2510	0.2593	0.2624	0.2600	0.2561	0.2485	0.0235	0.0307	0.0330	0.0306	
Model No. 12 β = 21°, 31°, 72°, 83°, 124°, 134°, 173° (See Text)	12.5°	0.3176	0.2942	0.2439	0.1904	0.1251	0.1341	0.1448	0.1429	0.1581	0.1550	0.0136	0.0137	0.0173	0.0192
	38.6°	0.3182	0.3006	0.2494	0.1991	0.1327	0.1532	0.1482	0.1675	0.1530	0.1633	0.0140	0.0137	0.0144	0.0160
	64.3°	0.3196	0.3030	0.2640	0.2093	0.1676	0.1842	0.1911	0.1831	0.1959	0.1813	0.0168	0.0142	0.0182	0.0152
	90.0°	0.3210	0.3129	0.2793	0.2387	0.1890	0.2120	0.1954	0.2134	0.1995	0.2088	0.0173	0.0213	0.0204	0.0216
	115.7°	0.3211	0.3198	0.2984	0.2549	0.2304	0.2392	0.2445	0.2306	0.2385	0.2226		0.0252	0.0298	0.0241
	141.4°	0.3221	0.3295	0.3105	0.2810	0.2473	0.2623	0.2483	0.2572	0.2429	0.2436	0.0225	0.0341	0.0320	0.0321
167.1°	0.3225	0.3290	0.3163	0.2896	0.2683	0.2742	0.2726	0.2685	0.2624	0.2537	0.0259	0.0362	0.0366	0.0336	
Model No. 12 β = 21°, 31°, 72°, 83°, 124°, 134°, 173° (See Text)	12.5°	0.3101	0.2829	0.2307	0.1791	0.1122	0.1182	0.1222	0.1281	0.1423	0.1396	0.0118	0.0129	0.0146	0.0185
	38.6°	0.3100	0.2922	0.2369	0.1872	0.1216	0.1447	0.1354	0.1531	0.1487	0.1539	0.0122	0.0124	0.0130	0.0128
	64.3°	0.3137	0.2936	0.2586	0.2001	0.1616	0.1644	0.1824	0.1697	0.1838	0.1670	0.0154	0.0130	0.0167	0.0127
	90.0°	0.3133	0.3087	0.2729	0.2387	0.1866	0.2090	0.1888	0.2087	0.1892	0.2000	0.0162	0.0219	0.0194	0.0206
	115.7°	0.3151	0.3139	0.2999	0.2591	0.2392	0.2399	0.2468	0.2288	0.2371	0.2137		0.0230	0.0314	0.0238
	141.4°	0.3171	0.3288	0.3132	0.2934	0.2584	0.2714	0.2618	0.2630	0.2448	0.2436	0.0236	0.0387	0.0340	0.0347
167.1°	0.3176	0.3274	0.3246	0.3046	0.2807	0.2817	0.2802	0.2746	0.2678	0.2571	0.0289	0.0422	0.0408	0.0372	
Model No. 12 β = 21°, 31°, 72°, 83°, 124°, 134°, 173° (See Text)	12.5°	0.3059	0.2715	0.2159	0.1615	0.1013	0.1055	0.1200	0.1159	0.1277	0.1235	0.0102	0.0119	0.0136	0.0185
	38.6°	0.3059	0.2825	0.2268	0.1743	0.1103	0.1361	0.1231	0.1394	0.1310	0.1399	0.0107	0.0111	0.0120	0.0097
	64.3°	0.3084	0.2852	0.2476	0.1917	0.1563	0.1573	0.1727	0.1544	0.1708	0.1538	0.0140	0.0118	0.0156	0.0103
	90.0°	0.3084	0.3042	0.2664	0.2352	0.1838	0.2050	0.1813	0.2052	0.1730	0.1928	0.0151	0.0226	0.0184	0.0198
	115.7°	0.3110	0.3076	0.2991	0.2605	0.2439	0.2313	0.2423	0.2260	0.2344	0.2140		0.0289	0.0327	0.0240
	141.4°	0.3112	0.3256	0.3116	0.3024	0.2667	0.2358	0.2550	0.2451	0.2445	0.2430	0.0246	0.0439	0.0361	0.0381
167.1°	0.3111	0.3238	0.3256	0.3092	0.2924	0.2916	0.2873	0.2801	0.2729	0.2609	0.0325	0.0484	0.0461	0.0414	
Model No. 12 β = 21°, 31°, 72°, 83°, 124°, 134°, 173° (See Text)	12.5°	0.2944	0.2590	0.1994	0.1445	0.0892	0.0943	0.1079	0.1018	0.1129	0.1121	0.0088	0.0109	0.0128	0.0186
	38.6°	0.2956	0.2677	0.2116	0.1616	0.0997	0.1244	0.1129	0.1285	0.1129	0.1255	0.0093	0.0096	0.0110	0.0073
	64.3°	0.2977	0.2730	0.2349	0.1836	0.1505	0.1444	0.1620	0.1422	0.1587	0.1394	0.0128	0.0106	0.0143	0.0082
	90.0°	0.2994	0.2937	0.2612	0.2287	0.1792	0.1997	0.1707	0.1962	0.1802	0.1844	0.0152	0.0234	0.0186	0.0192
	115.7°	0.3020	0.3004	0.2938	0.2593	0.2458	0.2280	0.2444	0.2228	0.2358	0.2090		0.0311	0.0341	0.0244
	141.4°	0.3036	0.3219	0.3145	0.3092	0.2723	0.2344	0.2581	0.2301	0.2482	0.2484	0.0260	0.0451	0.0381	0.0424
167.1°	0.3057	0.3232	0.3294	0.3164	0.3021	0.2982	0.2927	0.2810	0.2782	0.2652	0.0370	0.0558	0.0523	0.0470	

Table 7

(p/p₀) FOR MODELS 14 AND 15

TRUNCATED CONE-CYLINDER

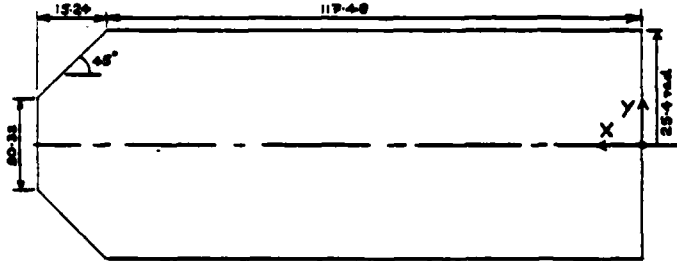

f	0.300
3σD	1
d/D	0.400
β	45
g	1
R/D	1

C_D(α=0°) = 1.0740

Model No.	14	15	14	15	14	15	14	15	14	15	14	15		
X	132.72	132.72	132.72	132.72	132.72	130.18	127.64	125.10	122.56	120.02	116.18	92.08	66.68	41.28
Y	0	2.54	5.08	7.62	9.50	12.70	15.24	17.78	20.32	22.86	25.40	25.40	25.40	25.40

α = 0° 0.3310 0.3292 0.3242 0.3083 0.2717 0.1699 0.2036 0.2101 0.2114 0.2150 0.0195 0.0207 0.0227 0.0248

α = 2.5°	β = 12.5°	0.3291	0.3227	0.3189	0.3007	0.2643	0.1460	0.1874	0.1897	0.1918	0.1944	0.0177	0.0190	0.0196	0.0240
	38.4°	0.3302	0.3228	0.3202	0.3039	0.2623	0.1498	0.1876	0.1968	0.1984	0.2090	0.0187	0.0195	0.0204	0.0228
	64.3°	0.3282	0.3276	0.3178	0.3057	0.2637	0.1508	0.1931	0.1984	0.1942	0.2055	0.0189	0.0196	0.0205	0.0237
	90.0°	0.3283	0.3267	0.3252	0.3081	0.2677	0.1607	0.2046	0.2145	0.2126	0.2198	0.0200	0.0210	0.0210	0.0243
	115.7°	0.3248	0.3284	0.3252	0.3118	0.2639	0.1793	0.2113	0.2167	0.2192	0.2209	0.0194	0.0224	0.0238	0.0255
	141.4°	0.3311	0.3309	0.3248	0.3120	0.2659	0.1976	0.2308	0.2280	0.2252	0.2285	0.0208	0.0225	0.0260	0.0240
167.1°	0.3294	0.3244	0.3292	0.3118	0.2697	0.2090	0.2292	0.2291	0.2292	0.2286	0.0211	0.0235	0.0261	0.0263	
α = 5°	β = 12.5°	0.3280	0.3193	0.3165	0.2971	0.2603	0.0940	0.1721	0.1717	0.1730	0.1833	0.0167	0.0182	0.0178	0.0218
	38.4°	0.3284	0.3203	0.3170	0.2997	0.2584	0.1421	0.1731	0.1835	0.1820	0.1934	0.0171	0.0181	0.0188	0.0202
	64.3°	0.3288	0.3209	0.3157	0.3034	0.2611	0.1443	0.1820	0.1872	0.1919	0.1973	0.0178	0.0186	0.0188	0.0217
	90.0°	0.3288	0.3238	0.3185	0.3034	0.2680	0.1788	0.2087	0.2138	0.2153	0.2187	0.0195	0.0208	0.0215	0.0234
	115.7°	0.3225	0.3234	0.3204	0.3072	0.2628	0.1943	0.2144	0.2214	0.2216	0.2272	0.0195	0.0228	0.0239	0.0254
	141.4°	0.3227	0.3298	0.3282	0.3123	0.2624	0.2395	0.2379	0.2387	0.2386	0.2369	0.0216	0.0240	0.0290	0.0274
167.1°	0.3259	0.3250	0.3238	0.3152	0.2634	0.2443	0.2396	0.2387	0.2413	0.2398	0.0220	0.0239	0.0292	0.0281	
α = 7.5°	β = 12.5°	0.3261	0.3184	0.3150	0.2958	0.2586	0.0920	0.1572	0.1567	0.1571	0.1645	0.0152	0.0162	0.0169	0.0200
	38.4°	0.3263	0.3198	0.3164	0.2981	0.2588	0.1400	0.1687	0.1794	0.1797	0.0162	0.0165	0.0175	0.0181	
	64.3°	0.3266	0.3184	0.3147	0.3000	0.2589	0.1424	0.1708	0.1788	0.1789	0.1877	0.0165	0.0170	0.0173	0.0191
	90.0°	0.3264	0.3214	0.3157	0.3044	0.2671	0.1923	0.2122	0.2137	0.2129	0.2153	0.0188	0.0212	0.0219	0.0221
	115.7°	0.3212	0.3204	0.3185	0.3031	0.2644	0.2172	0.2198	0.2235	0.2216	0.2224	0.0193	0.0207	0.0235	0.0252
	141.4°	0.3211	0.3244	0.3238	0.3135	0.2648	0.2398	0.2321	0.2381	0.2383	0.2413	0.0220	0.0244	0.0321	0.0292
167.1°	0.3220	0.3223	0.3228	0.3172	0.2601	0.2584	0.2535	0.2535	0.2594	0.2457	0.0224	0.0327	0.0327	0.0309	
α = 10°	β = 12.5°	0.3281	0.3191	0.3167	0.2984	0.2619	0.0934	0.1116	0.1094	0.1143	0.1184	0.0156	0.0163	0.0172	0.0186
	38.4°	0.3284	0.3202	0.3161	0.2919	0.2540	0.1131	0.1481	0.1547	0.1536	0.1628	0.0146	0.0146	0.0158	0.0157
	64.3°	0.3251	0.3199	0.3139	0.2992	0.2544	0.1314	0.1420	0.1688	0.1649	0.1747	0.0156	0.0162	0.0157	0.0160
	90.0°	0.3239	0.3247	0.3178	0.3045	0.2605	0.2044	0.2140	0.2128	0.2113	0.2122	0.0185	0.0215	0.0251	0.0209
	115.7°	0.3248	0.3240	0.3214	0.3080	0.2639	0.2304	0.2230	0.2244	0.2204	0.2203	0.0186	0.0223	0.0261	0.0248
	141.4°	0.3229	0.3235	0.3226	0.3163	0.2628	0.2495	0.2434	0.2414	0.2359	0.2453	0.0224	0.0351	0.0358	0.0312
167.1°	0.3247	0.3257	0.3229	0.3172	0.2644	0.2677	0.2652	0.2647	0.2691	0.2572	0.0227	0.0393	0.0368	0.0340	
α = 12.5°	β = 12.5°	0.3218	0.3134	0.3084	0.2870	0.2492	0.0901	0.1224	0.1311	0.1338	0.0120	0.0148	0.0172	0.0184	
	38.4°	0.3194	0.3159	0.3081	0.2851	0.2485	0.1051	0.1353	0.1434	0.1441	0.1473	0.0133	0.0124	0.0138	0.0130
	64.3°	0.3209	0.3164	0.3081	0.2938	0.2450	0.1204	0.1539	0.1584	0.1551	0.1623	0.0155	0.0139	0.0140	0.0130
	90.0°	0.3208	0.3207	0.3168	0.3013	0.2494	0.2135	0.2086	0.2100	0.2065	0.0175	0.0221	0.0253	0.0198	
	115.7°	0.3212	0.3211	0.3206	0.3011	0.2334	0.2337	0.2383	0.2243	0.2197	0.2196	0.0176	0.0293	0.0263	0.0249
	141.4°	0.3204	0.3257	0.3256	0.3214	0.2623	0.2337	0.2318	0.2124	0.2392	0.2492	0.0228	0.0401	0.0396	0.0341
167.1°	0.3208	0.3249	0.3224	0.3253	0.3074	0.2829	0.2794	0.2794	0.2632	0.2570	0.0230	0.0448	0.0406	0.0377	
α = 15°	β = 12.5°	0.3162	0.3083	0.2988	0.2755	0.2377	0.0873	0.0780	0.1061	0.1169	0.1217	0.0110	0.0131	0.0169	0.0186
	38.4°	0.3163	0.3115	0.3024	0.2814	0.2411	0.0932	0.1267	0.1334	0.1356	0.1353	0.0122	0.0107	0.0119	0.0105
	64.3°	0.3159	0.3123	0.3031	0.2867	0.2416	0.1096	0.1447	0.1451	0.1493	0.1518	0.0121	0.0113	0.0123	0.0108
	90.0°	0.3158	0.3170	0.3144	0.2948	0.2431	0.2088	0.2113	0.2044	0.2054	0.2004	0.0168	0.0228	0.0253	0.0189
	115.7°	0.3162	0.3183	0.3159	0.3009	0.2309	0.2374	0.2244	0.2267	0.2173	0.2184	0.0173	0.0314	0.0267	0.0253
	141.4°	0.3165	0.3232	0.3210	0.3224	0.3108	0.2813	0.2377	0.2448	0.2439	0.2514	0.0228	0.0458	0.0458	0.0373
167.1°	0.3167	0.3219	0.3242	0.3244	0.3158	0.2935	0.2817	0.2783	0.2683	0.2612	0.0230	0.0507	0.0444	0.0422	
α = 17.5°	β = 12.5°	0.3127	0.3024	0.2921	0.2674	0.2298	0.0884	0.0602	0.0887	0.1021	0.1098	0.0099	0.0119	0.0156	0.0186
	38.4°	0.3123	0.3085	0.2952	0.2745	0.2350	0.0783	0.1137	0.1213	0.1268	0.1229	0.0111	0.0092	0.0101	0.0087
	64.3°	0.3125	0.3053	0.2993	0.2793	0.2399	0.1007	0.1410	0.1401	0.1328	0.1403	0.0114	0.0115	0.0106	0.0088
	90.0°	0.3153	0.3125	0.3140	0.2977	0.2477	0.2051	0.2120	0.1984	0.2090	0.1919	0.0170	0.0231	0.0255	0.0183
	115.7°	0.3127	0.3129	0.3112	0.3009	0.2482	0.2373	0.2225	0.2225	0.2131	0.2134	0.0165	0.0341	0.0270	0.0262
	141.4°	0.3124	0.3200	0.3221	0.3193	0.3182	0.2886	0.2781	0.2719	0.2679	0.2537	0.0233	0.0454	0.0480	0.0414
167.1°	0.3124	0.3196	0.3219	0.3249	0.3175	0.3015	0.2903	0.2841	0.2735	0.2649	0.0238	0.0519	0.0501	0.0481	

Table 8
(p/p₀) FOR MODELS 16 AND 17

SPHERICALLY-BLUNTED CONE-CYLINDER

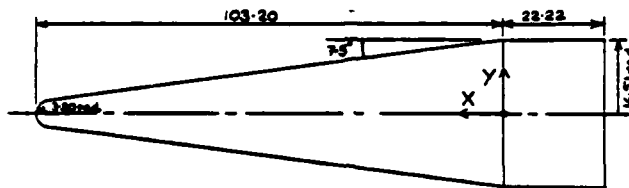

f	3-12.5
2r/b	0-198
d/D	0-200
g	7.5
G	
R/D	

C_{Dp(α=0°)} = 0.0600

Model No.	16	17	16	17	16	17	16	17	16	17	16
X	103.20	102.76	100.33	87.79	75.25	63.67	50.17	37.63	25.09	12.55	0
Y	0	1.65	3.30	4.95	6.60	8.19	9.91	11.56	13.21	14.86	16.51

α = 0°	0.3277	0.2629	0.0384	0.0333	0.0339	0.0339	0.0341	0.0340	0.0344	0.0343	0.0294
--------	--------	--------	--------	--------	--------	--------	--------	--------	--------	--------	--------

α	β	12.9°	38.4°	64.3°	90.0°	115.7°	141.4°	167.1°
α = 2.5°	β = 12.9°	0.3236	0.2519	0.0348	0.0306	0.0313	0.0311	0.0311
	β = 38.4°	0.3261	0.2308	0.0346	0.0315	0.0314	0.0309	0.0315
	β = 64.3°	0.3245	0.2385	0.0362	0.0322	0.0326	0.0326	0.0332
	β = 90.0°	0.3241	0.2339	0.0378	0.0331	0.0332	0.0331	0.0337
	β = 115.7°	0.3252	0.2469	0.0412	0.0352	0.0355	0.0355	0.0357
	β = 141.4°	0.3229	0.2492	0.0423	0.0353	0.0363	0.0369	0.0370
	β = 167.1°	0.3242	0.2729	0.0457	0.0390	0.0385	0.0374	0.0374
	α = 5°	β = 12.9°	0.3228	0.2420	0.0296	0.0284	0.0288	0.0290
β = 38.4°		0.3262	0.2441	0.0312	0.0288	0.0288	0.0284	0.0297
β = 64.3°		0.3239	0.2578	0.0344	0.0300	0.0304	0.0299	0.0311
β = 90.0°		0.3233	0.2587	0.0379	0.0331	0.0319	0.0320	0.0324
β = 115.7°		0.3241	0.2707	0.0434	0.0365	0.0364	0.0366	0.0367
β = 141.4°		0.3229	0.2759	0.0443	0.0388	0.0395	0.0401	0.0404
β = 167.1°		0.3240	0.2844	0.0482	0.0420	0.0424	0.0423	0.0429
α = 7.5°		β = 12.9°	0.3233	0.2292	0.0287	0.0262	0.0263	0.0274
	β = 38.4°	0.3234	0.2338	0.0286	0.0262	0.0259	0.0258	0.0269
	β = 64.3°	0.3233	0.2435	0.0323	0.0275	0.0274	0.0268	0.0273
	β = 90.0°	0.3231	0.2583	0.0381	0.0321	0.0301	0.0298	0.0303
	β = 115.7°	0.3240	0.2756	0.0455	0.0388	0.0378	0.0374	0.0371
	β = 141.4°	0.3232	0.2834	0.0512	0.0436	0.0438	0.0444	0.0444
	β = 167.1°	0.3238	0.2922	0.0555	0.0468	0.0486	0.0481	0.0490
	α = 10°	β = 12.9°	0.3195	0.2174	0.0226	0.0200	0.0203	0.0204
β = 38.4°		0.3192	0.2236	0.0252	0.0225	0.0228	0.0224	0.0227
β = 64.3°		0.3188	0.2407	0.0304	0.0248	0.0235	0.0222	0.0222
β = 90.0°		0.3188	0.2553	0.0380	0.0306	0.0277	0.0270	0.0273
β = 115.7°		0.3192	0.2740	0.0458	0.0402	0.0397	0.0389	0.0389
β = 141.4°		0.3182	0.2898	0.0534	0.0462	0.0467	0.0465	0.0461
β = 167.1°		0.3198	0.3000	0.0628	0.0536	0.0561	0.0557	0.0568
α = 12.5°		β = 12.9°	0.3189	0.2060	0.0188	0.0221	0.0224	0.0247
	β = 38.4°	0.3178	0.2136	0.0221	0.0208	0.0199	0.0208	0.0222
	β = 64.3°	0.3177	0.2395	0.0285	0.0218	0.0189	0.0174	0.0170
	β = 90.0°	0.3180	0.2453	0.0382	0.0291	0.0256	0.0230	0.0237
	β = 115.7°	0.3182	0.2825	0.0512	0.0421	0.0416	0.0413	0.0419
	β = 141.4°	0.3181	0.2917	0.0631	0.0527	0.0544	0.0533	0.0549
	β = 167.1°	0.3191	0.3097	0.0704	0.0614	0.0649	0.0630	0.0653
	α = 15°	β = 12.9°	0.3125	0.1885	0.0166	0.0201	0.0216	0.0215
β = 38.4°		0.3120	0.1992	0.0186	0.0187	0.0171	0.0171	0.0175
β = 64.3°		0.3105	0.2249	0.0267	0.0191	0.0157	0.0144	0.0141
β = 90.0°		0.3107	0.2453	0.0374	0.0295	0.0237	0.0224	0.0241
β = 115.7°		0.3119	0.2810	0.0544	0.0447	0.0488	0.0436	0.0444
β = 141.4°		0.3124	0.2994	0.0685	0.0588	0.0605	0.0594	0.0609
β = 167.1°		0.3130	0.3152	0.0815	0.0702	0.0745	0.0723	0.0748
α = 17.5°		β = 12.9°	0.3046	0.1723	0.0141	0.0174	0.0168	0.0153
	β = 38.4°	0.3040	0.1834	0.0171	0.0158	0.0135	0.0134	0.0143
	β = 64.3°	0.3023	0.2172	0.0257	0.0159	0.0129	0.0125	0.0123
	β = 90.0°	0.3023	0.2374	0.0373	0.0269	0.0222	0.0205	0.0215
	β = 115.7°	0.3034	0.2811	0.0572	0.0475	0.0469	0.0473	0.0479
	β = 141.4°	0.3044	0.3002	0.0754	0.0655	0.0676	0.0662	0.0679
	β = 167.1°	0.3050	0.3203	0.0931	0.0812	0.0852	0.0830	0.0847

Table 9

(p/p₀) FOR MODELS 18 AND 19

TRUNCATED CONE-CYLINDER

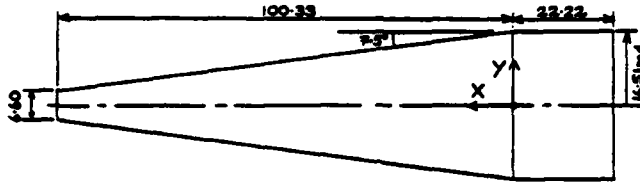

f	3.038
2-r/D	
d/D	0.200
β	7.5
g	
R/D	

C_D(α=0°) = 0.0940

Model No.	18	19	18	19	18	19	18	19	18	19	18	19	18
X	100.33	100.33	100.26	87.79	79.25	62.67	50.17	37.63	25.09	12.55	0		
Y	0	1.65	3.31	4.95	6.60	8.13	9.91	11.56	13.21	14.86	16.51		

α = 0°	0.3268	0.3219	0.0157	0.0340	0.0332	0.0332	0.0336	0.0335	0.0342	0.0340	0.0290		
--------	--------	--------	--------	--------	--------	--------	--------	--------	--------	--------	--------	--	--

α = 2.5° β =	12.5°	0.3229	0.3169	0.0163	0.0320	0.0306	0.0305	0.0310	0.0310	0.0315	0.0314	0.0249	
	38.5°	0.3248	0.3162	0.0161	0.0330	0.0304	0.0304	0.0318	0.0312	0.0323	0.0315	0.0280	
	64.5°	0.3229	0.3184	0.0156	0.0328	0.0321	0.0321	0.0328	0.0318	0.0322	0.0319	0.0273	
	90.0°	0.3258	0.3189	0.0150	0.0342	0.0324	0.0328	0.0329	0.0336	0.0343	0.0341	0.0294	
	115.7°	0.3234	0.3195	0.0155	0.0356	0.0346	0.0346	0.0350	0.0344	0.0356	0.0349	0.0299	
	141.4°	0.3241	0.3187	0.0151	0.0359	0.0350	0.0342	0.0348	0.0340	0.0371	0.0344	0.0309	
167.1°	0.3234	0.3222	0.0160	0.0371	0.0361	0.0366	0.0369	0.0369	0.0378	0.0371	0.0316		
α = 5° β =	12.5°	0.3231	0.3161	0.0165	0.0300	0.0283	0.0283	0.0290	0.0290	0.0293	0.0295	0.0254	
	38.5°	0.3251	0.3153	0.0156	0.0304	0.0283	0.0282	0.0295	0.0292	0.0300	0.0295	0.0256	
	64.5°	0.3236	0.3178	0.0146	0.0310	0.0302	0.0302	0.0304	0.0293	0.0296	0.0294	0.0249	
	90.0°	0.3241	0.3178	0.0145	0.0342	0.0313	0.0316	0.0317	0.0321	0.0328	0.0325	0.0277	
	115.7°	0.3248	0.3202	0.0152	0.0371	0.0351	0.0351	0.0362	0.0353	0.0365	0.0359	0.0306	
	141.4°	0.3242	0.3204	0.0161	0.0391	0.0376	0.0375	0.0389	0.0390	0.0403	0.0396	0.0333	
167.1°	0.3240	0.3244	0.0180	0.0414	0.0408	0.0414	0.0419	0.0414	0.0426	0.0416	0.0353		
α = 7.5° β =	12.5°	0.3238	0.3155	0.0154	0.0279	0.0264	0.0267	0.0274	0.0272	0.0274	0.0276	0.0237	
	38.5°	0.3242	0.3134	0.0146	0.0272	0.0260	0.0263	0.0273	0.0270	0.0278	0.0267	0.0229	
	64.5°	0.3242	0.3161	0.0138	0.0291	0.0283	0.0285	0.0288	0.0288	0.0290	0.0290	0.0244	
	90.0°	0.3237	0.3190	0.0133	0.0333	0.0303	0.0308	0.0304	0.0302	0.0305	0.0304	0.0255	
	115.7°	0.3234	0.3216	0.0187	0.0391	0.0369	0.0373	0.0374	0.0364	0.0375	0.0368	0.0310	
	141.4°	0.3244	0.3241	0.0184	0.0432	0.0422	0.0421	0.0438	0.0430	0.0443	0.0433	0.0362	
167.1°	0.3248	0.3234	0.0212	0.0468	0.0469	0.0477	0.0485	0.0471	0.0488	0.0474	0.0406		
α = 10° β =	12.5°	0.3213	0.3100	0.0128	0.0256	0.0253	0.0253	0.0259	0.0253	0.0256	0.0253	0.0219	
	38.5°	0.3236	0.3109	0.0125	0.0264	0.0263	0.0265	0.0268	0.0268	0.0270	0.0271	0.0234	
	64.5°	0.3224	0.3140	0.0112	0.0267	0.0257	0.0257	0.0265	0.0269	0.0272	0.0274	0.0237	
	90.0°	0.3212	0.3171	0.0123	0.0317	0.0291	0.0291	0.0294	0.0294	0.0295	0.0295	0.0255	
	115.7°	0.3207	0.3205	0.0167	0.0408	0.0389	0.0393	0.0394	0.0380	0.0393	0.0381	0.0320	
	141.4°	0.3221	0.3230	0.0218	0.0473	0.0474	0.0482	0.0489	0.0476	0.0488	0.0481	0.0401	
167.1°	0.3225	0.3232	0.0236	0.0540	0.0545	0.0562	0.0563	0.0566	0.0568	0.0568	0.0528		
α = 12.5° β =	12.5°	0.3220	0.3094	0.0107	0.0231	0.0242	0.0240	0.0237	0.0224	0.0223	0.0223	0.0185	
	38.5°	0.3236	0.3085	0.0102	0.0217	0.0215	0.0224	0.0221	0.0222	0.0226	0.0218	0.0187	
	64.5°	0.3220	0.3144	0.0099	0.0243	0.0251	0.0254	0.0264	0.0264	0.0266	0.0265	0.0229	
	90.0°	0.3222	0.3188	0.0119	0.0308	0.0290	0.0294	0.0296	0.0296	0.0296	0.0295	0.0257	
	115.7°	0.3230	0.3229	0.0180	0.0424	0.0416	0.0419	0.0422	0.0403	0.0416	0.0399	0.0336	
	141.4°	0.3224	0.3241	0.0214	0.0530	0.0531	0.0535	0.0549	0.0532	0.0546	0.0534	0.0468	
167.1°	0.3224	0.3321	0.0308	0.0646	0.0648	0.0646	0.0658	0.0677	0.0680	0.0676	0.0535		
α = 15° β =	12.5°	0.3224	0.3074	0.0098	0.0204	0.0232	0.0217	0.0203	0.0198	0.0192	0.0198	0.0158	
	38.5°	0.3211	0.3046	0.0095	0.0183	0.0181	0.0182	0.0187	0.0179	0.0179	0.0172	0.0154	
	64.5°	0.3198	0.3093	0.0091	0.0218	0.0213	0.0218	0.0210	0.0213	0.0219	0.0211	0.0171	
	90.0°	0.3181	0.3152	0.0119	0.0298	0.0285	0.0283	0.0283	0.0284	0.0289	0.0287	0.0241	
	115.7°	0.3189	0.3204	0.0209	0.0442	0.0440	0.0449	0.0453	0.0450	0.0442	0.0423	0.0354	
	141.4°	0.3189	0.3248	0.0321	0.0598	0.0585	0.0580	0.0607	0.0584	0.0606	0.0593	0.0491	
167.1°	0.3189	0.3307	0.0480	0.0788	0.0783	0.0788	0.0796	0.0772	0.0790	0.0780	0.0606		
α = 17.5° β =	12.5°	0.3149	0.2943	0.0088	0.0182	0.0209	0.0170	0.0163	0.0119	0.0152	0.0127	0.0100	
	38.5°	0.3157	0.2900	0.0085	0.0150	0.0140	0.0130	0.0130	0.0151	0.0155	0.0148	0.0130	
	64.5°	0.3151	0.3043	0.0086	0.0192	0.0194	0.0199	0.0196	0.0211	0.0216	0.0217	0.0209	
	90.0°	0.3141	0.3104	0.0118	0.0286	0.0282	0.0282	0.0289	0.0287	0.0283	0.0286	0.0236	
	115.7°	0.3144	0.3166	0.0239	0.0483	0.0477	0.0488	0.0488	0.0441	0.0472	0.0453	0.0379	
	141.4°	0.3140	0.3214	0.0404	0.0653	0.0652	0.0669	0.0669	0.0644	0.0679	0.0657	0.0544	
167.1°	0.3142	0.3286	0.0522	0.0833	0.0839	0.0840	0.0844	0.0817	0.0848	0.0810	0.0691		

Table 10
(p/p₀) FOR MODELS 20 AND 21

SPHERICALLY-BLUNTED CONE-CYLINDER

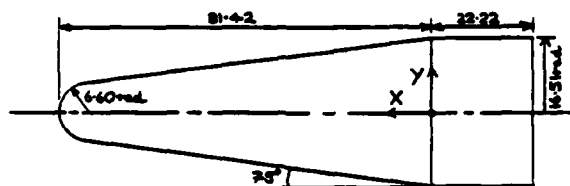

f	2.446
2r/D	0.397
d/D	0.400
β	7.5
α	
R/D	

C_{Dp(α=0°)} = 0.1600

Model No.	20	21	20	21	20	21	20	21	20	21	20
X	81.42	81.21	80.53	79.18	78.24	63.46	50.17	37.61	25.07	12.53	0
Y	0	1.65	3.30	4.95	6.60	8.13	9.91	11.56	13.21	14.86	16.51

α = 0°	0.3267	0.3116	0.2541	0.1530	0.0848	0.0340	0.0225	0.0226	0.0329	0.0334	0.0271
--------	--------	--------	--------	--------	--------	--------	--------	--------	--------	--------	--------

α = 2.5°	β =	12.5°	0.3231	0.3056	0.2444	0.1434	0.0768	0.0302	0.0299	0.0300	0.0300	0.0302	0.0258
		38.6°	0.3235	0.3099	0.2489	0.1438	0.0806	0.0308	0.0302	0.0301	0.0309	0.0315	0.0264
		64.3°	0.3248	0.3113	0.2493	0.1431	0.0827	0.0329	0.0317	0.0311	0.0312	0.0314	0.0262
		90.0°	0.3257	0.3123	0.2507	0.1428	0.0858	0.0339	0.0319	0.0331	0.0327	0.0342	0.0260
		115.7°	0.3262	0.3129	0.2530	0.1424	0.0884	0.0340	0.0344	0.0342	0.0341	0.0344	0.0262
		141.4°	0.3264	0.3146	0.2549	0.1413	0.0911	0.0347	0.0351	0.0353	0.0361	0.0363	0.0262
167.1°	0.3272	0.3173	0.2639	0.1440	0.0988	0.0392	0.0356	0.0362	0.0362	0.0368	0.0296		
α = 5°	β =	12.5°	0.3231	0.3059	0.2380	0.1312	0.0261	0.0275	0.0275	0.0274	0.0282	0.0284	0.0243
		38.6°	0.3263	0.3042	0.2395	0.1333	0.0278	0.0280	0.0279	0.0280	0.0292	0.0293	0.0245
		64.3°	0.3257	0.3083	0.2444	0.1420	0.0309	0.0312	0.0297	0.0288	0.0284	0.0294	0.0246
		90.0°	0.3273	0.3108	0.2542	0.1574	0.0334	0.0344	0.0311	0.0322	0.0321	0.0330	0.0272
		115.7°	0.3252	0.3162	0.2428	0.1442	0.0289	0.0321	0.0351	0.0353	0.0353	0.0358	0.0299
		141.4°	0.3255	0.3190	0.2504	0.1710	0.0441	0.0400	0.0381	0.0385	0.0380	0.0385	0.0319
167.1°	0.3256	0.3172	0.2340	0.1790	0.0441	0.0432	0.0404	0.0408	0.0409	0.0413	0.0336		
α = 7.5°	β =	12.5°	0.3230	0.2944	0.2217	0.1184	0.0224	0.0248	0.0254	0.0258	0.0263	0.0268	0.0232
		38.6°	0.3259	0.2990	0.2241	0.1223	0.0239	0.0254	0.0254	0.0255	0.0271	0.0270	0.0223
		64.3°	0.3258	0.3044	0.2388	0.1352	0.0292	0.0295	0.0284	0.0285	0.0284	0.0284	0.0218
		90.0°	0.3258	0.3088	0.2509	0.1423	0.0338	0.0323	0.0304	0.0309	0.0304	0.0308	0.0253
		115.7°	0.3259	0.3124	0.2448	0.1703	0.0412	0.0402	0.0385	0.0384	0.0367	0.0369	0.0309
		141.4°	0.3259	0.3229	0.2393	0.1819	0.0457	0.0444	0.0418	0.0424	0.0429	0.0434	0.0351
167.1°	0.3257	0.3216	0.2854	0.1907	0.0503	0.0491	0.0461	0.0463	0.0464	0.0470	0.0386		
α = 10°	β =	12.5°	0.3216	0.2834	0.2073	0.1061	0.0193	0.0223	0.0235	0.0244	0.0254	0.0253	0.0218
		38.6°	0.3204	0.2889	0.2123	0.1107	0.0210	0.0230	0.0231	0.0228	0.0241	0.0247	0.0199
		64.3°	0.3204	0.2939	0.2201	0.1297	0.0233	0.0234	0.0247	0.0230	0.0224	0.0216	0.0177
		90.0°	0.3210	0.3035	0.2446	0.1463	0.0295	0.0314	0.0293	0.0289	0.0283	0.0272	0.0232
		115.7°	0.3214	0.3138	0.2321	0.1757	0.0439	0.0425	0.0392	0.0388	0.0385	0.0384	0.0319
		141.4°	0.3212	0.3224	0.2444	0.1912	0.0510	0.0488	0.0463	0.0468	0.0477	0.0481	0.0391
167.1°	0.3208	0.3243	0.2941	0.2049	0.0567	0.0558	0.0529	0.0534	0.0538	0.0539	0.0448		
α = 12.5°	β =	12.5°	0.3144	0.2822	0.1941	0.0851	0.0165	0.0204	0.0217	0.0233	0.0243	0.0240	0.0205
		38.6°	0.3182	0.2754	0.2007	0.1013	0.0185	0.0209	0.0198	0.0198	0.0212	0.0223	0.0180
		64.3°	0.3124	0.2898	0.2213	0.1215	0.0258	0.0232	0.0216	0.0196	0.0185	0.0174	0.0140
		90.0°	0.3134	0.2942	0.2408	0.1443	0.0322	0.0309	0.0281	0.0272	0.0263	0.0248	0.0213
		115.7°	0.3135	0.3111	0.2322	0.1797	0.0444	0.0437	0.0411	0.0402	0.0404	0.0409	0.0333
		141.4°	0.3141	0.3201	0.2385	0.1984	0.0514	0.0514	0.0517	0.0522	0.0532	0.0532	0.0434
167.1°	0.3131	0.3248	0.3042	0.2174	0.0640	0.0628	0.0608	0.0612	0.0621	0.0624	0.0513		
α = 15°	β =	12.5°	0.3049	0.2413	0.1818	0.0854	0.0143	0.0189	0.0200	0.0222	0.0230	0.0222	0.0184
		38.6°	0.3068	0.2451	0.1884	0.0923	0.0165	0.0182	0.0169	0.0162	0.0174	0.0181	0.0140
		64.3°	0.3053	0.2817	0.2140	0.1149	0.0242	0.0236	0.0219	0.0164	0.0153	0.0143	0.0116
		90.0°	0.3076	0.2897	0.2347	0.1409	0.0319	0.0298	0.0268	0.0257	0.0250	0.0238	0.0202
		115.7°	0.3063	0.3044	0.2316	0.1838	0.0481	0.0492	0.0484	0.0482	0.0472	0.0451	0.0352
		141.4°	0.3045	0.3149	0.2394	0.2081	0.0643	0.0572	0.0535	0.0580	0.0588	0.0593	0.0487
167.1°	0.3049	0.3237	0.3084	0.2293	0.0723	0.0708	0.0695	0.0704	0.0711	0.0714	0.0584		
α = 17.5°	β =	12.5°	0.2988	0.2489	0.1159	0.0734	0.0120	0.0168	0.0189	0.0215	0.0199	0.0172	0.0147
		38.6°	0.2985	0.2528	0.1390	0.0833	0.0145	0.0163	0.0134	0.0128	0.0128	0.0129	0.0116
		64.3°	0.2973	0.2710	0.2045	0.1059	0.0224	0.0212	0.0163	0.0141	0.0128	0.0122	0.0100
		90.0°	0.2985	0.2811	0.2278	0.1347	0.0316	0.0291	0.0257	0.0244	0.0239	0.0230	0.0195
		115.7°	0.2979	0.3013	0.2303	0.1823	0.0521	0.0490	0.0444	0.0445	0.0441	0.0443	0.0379
		141.4°	0.2990	0.3130	0.2920	0.2133	0.0672	0.0640	0.0644	0.0651	0.0645	0.0641	0.0528
167.1°	0.2984	0.3209	0.3135	0.2399	0.0821	0.0804	0.0808	0.0813	0.0818	0.0816	0.0667		

Table 11
 (p/p_0) FOR MODELS 22 AND 23

TRUNCATED CONE-CYLINDER

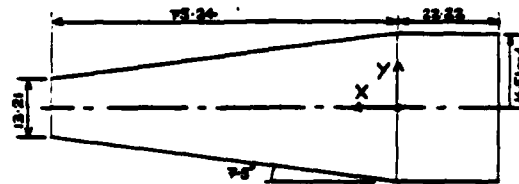

f	2.279
2v/D	
d/D	0.400
β	7.5
δ	
R/D	

$C_{p_{(x=0)}} = 0.2780$

Model No.	22	23	22	23	22	23	22	23	22	23	22	23
X	75.24	75.24	75.24	75.24	75.17	69.66	50.15	37.61	25.07	12.53	0	0
Y	0	1.65	3.30	4.95	6.61	8.13	9.91	11.56	13.31	14.86	16.51	

$\alpha = 0^\circ$ 0.3274 0.3250 0.3206 0.3080 0.0142 0.0345 0.0540 0.0733 0.0926 0.0325 0.0283

$\alpha = 2.5^\circ$	$\beta =$	12.5	0.3212	0.3241	0.3194	0.3074	0.0131	0.0322	0.0510	0.0697	0.0299	0.0296	0.0252
		39.4	0.3249	0.3262	0.3222	0.3043	0.0230	0.0327	0.0517	0.0702	0.0305	0.0305	0.0268
		64.5	0.3282	0.3256	0.3212	0.3062	0.0128	0.0337	0.0523	0.0706	0.0309	0.0308	0.0268
		90.0	0.3212	0.3253	0.3194	0.3115	0.0124	0.0335	0.0532	0.0725	0.0324	0.0333	0.0284
		115.7	0.3249	0.3232	0.3219	0.3097	0.0124	0.0339	0.0544	0.0735	0.0337	0.0334	0.0295
		141.4	0.3245	0.3247	0.3220	0.3022	0.0135	0.0343	0.0555	0.0744	0.0338	0.0331	0.0303
167.1	0.3271	0.3240	0.3219	0.3087	0.0134	0.0349	0.0562	0.0753	0.0339	0.0337	0.0308		
$\alpha = 5^\circ$	$\beta =$	12.5	0.3235	0.3250	0.3135	0.3031	0.0125	0.0378	0.0571	0.0757	0.0338	0.0337	0.0243
		39.4	0.3282	0.3244	0.3192	0.3031	0.0124	0.0338	0.0537	0.0732	0.0339	0.0334	0.0247
		64.5	0.3282	0.3242	0.3210	0.3050	0.0120	0.0340	0.0538	0.0737	0.0339	0.0330	0.0248
		90.0	0.3214	0.3273	0.3204	0.3102	0.0113	0.0334	0.0526	0.0717	0.0315	0.0324	0.0233
		115.7	0.3273	0.3239	0.3226	0.3100	0.0113	0.0343	0.0538	0.0749	0.0331	0.0332	0.0246
		141.4	0.3253	0.3233	0.3245	0.3151	0.0129	0.0343	0.0539	0.0738	0.0339	0.0333	0.0239
167.1	0.3282	0.3212	0.3239	0.3140	0.0132	0.0342	0.0546	0.0741	0.0343	0.0341	0.0251		
$\alpha = 7.5^\circ$	$\beta =$	12.5	0.3231	0.3279	0.3153	0.2981	0.0118	0.0373	0.0573	0.0764	0.0344	0.0343	0.0240
		39.4	0.3282	0.3242	0.3147	0.2980	0.0119	0.0336	0.0534	0.0741	0.0339	0.0344	0.0244
		64.5	0.3281	0.3249	0.3211	0.3064	0.0108	0.0330	0.0526	0.0733	0.0341	0.0337	0.0244
		90.0	0.3237	0.3248	0.3183	0.3082	0.0104	0.0335	0.0524	0.0708	0.0339	0.0335	0.0253
		115.7	0.3281	0.3239	0.3253	0.3111	0.0114	0.0348	0.0537	0.0744	0.0346	0.0338	0.0242
		141.4	0.3253	0.3235	0.3235	0.3153	0.0136	0.0348	0.0538	0.0738	0.0339	0.0332	0.0244
167.1	0.3238	0.3235	0.3234	0.3159	0.0151	0.0373	0.0543	0.0749	0.0344	0.0340	0.0247		
$\alpha = 10^\circ$	$\beta =$	12.5	0.3245	0.3186	0.3102	0.2913	0.0101	0.0373	0.0574	0.0761	0.0331	0.0338	0.0218
		39.4	0.3253	0.3204	0.3085	0.2921	0.0100	0.0373	0.0565	0.0741	0.0348	0.0343	0.0228
		64.5	0.3233	0.3279	0.3187	0.3034	0.0098	0.0338	0.0532	0.0735	0.0324	0.0324	0.0186
		90.0	0.3254	0.3213	0.3157	0.3044	0.0088	0.0333	0.0513	0.0721	0.0280	0.0278	0.0233
		115.7	0.3245	0.3232	0.3219	0.3148	0.0124	0.0343	0.0539	0.0744	0.0336	0.0337	0.0239
		141.4	0.3224	0.3248	0.3242	0.3139	0.0142	0.0331	0.0534	0.0744	0.0343	0.0340	0.0248
167.1	0.3242	0.3241	0.3235	0.3234	0.0182	0.0332	0.0534	0.0732	0.0339	0.0337	0.0247		
$\alpha = 12.5^\circ$	$\beta =$	12.5	0.3203	0.3143	0.3034	0.2857	0.0083	0.0373	0.0573	0.0763	0.0338	0.0338	0.0204
		39.4	0.3223	0.3144	0.3037	0.2872	0.0085	0.0316	0.0512	0.0716	0.0226	0.0224	0.0182
		64.5	0.3224	0.3179	0.3133	0.2976	0.0078	0.0335	0.0523	0.0734	0.0225	0.0210	0.0145
		90.0	0.3223	0.3182	0.3120	0.3013	0.0081	0.0338	0.0505	0.0737	0.0244	0.0233	0.0218
		115.7	0.3202	0.3245	0.3251	0.3148	0.0142	0.0346	0.0492	0.0705	0.0280	0.0289	0.0251
		141.4	0.3183	0.3273	0.3256	0.3188	0.0156	0.0373	0.0530	0.0726	0.0246	0.0241	0.0240
167.1	0.3200	0.3233	0.3304	0.3253	0.0216	0.0451	0.0620	0.0617	0.0630	0.0628	0.0333		
$\alpha = 15^\circ$	$\beta =$	12.5	0.3154	0.3083	0.2986	0.2797	0.0078	0.0394	0.0589	0.0779	0.0273	0.0274	0.0186
		39.4	0.3180	0.3102	0.2981	0.2816	0.0074	0.0208	0.0180	0.0185	0.0199	0.0191	0.0144
		64.5	0.3190	0.3176	0.3082	0.2924	0.0064	0.0279	0.0212	0.0178	0.0160	0.0153	0.0119
		90.0	0.3182	0.3139	0.3074	0.2979	0.0074	0.0354	0.0294	0.0244	0.0257	0.0253	0.0211
		115.7	0.3164	0.3206	0.3220	0.3131	0.0158	0.0311	0.0249	0.0232	0.0237	0.0249	0.0233
		141.4	0.3145	0.3198	0.3224	0.3193	0.0131	0.0424	0.0356	0.0339	0.0412	0.0398	0.0344
167.1	0.3161	0.3210	0.3281	0.3277	0.0200	0.0333	0.0313	0.0314	0.0332	0.0323	0.0430		
$\alpha = 17.5^\circ$	$\beta =$	12.5	0.3110	0.3034	0.2924	0.2734	0.0070	0.0373	0.0573	0.0763	0.0282	0.0283	0.0182
		39.4	0.3127	0.3045	0.2930	0.2758	0.0068	0.0184	0.0143	0.0152	0.0150	0.0132	0.0120
		64.5	0.3140	0.3139	0.3029	0.2867	0.0059	0.0215	0.0189	0.0152	0.0134	0.0120	0.0104
		90.0	0.3114	0.3092	0.3031	0.2934	0.0059	0.0351	0.0286	0.0254	0.0243	0.0238	0.0209
		115.7	0.3114	0.3162	0.3178	0.3095	0.0134	0.0340	0.0281	0.0245	0.0245	0.0246	0.2022
		141.4	0.3102	0.3183	0.3194	0.3142	0.0203	0.0432	0.0373	0.0425	0.0421	0.0424	0.0371
167.1	0.3109	0.3172	0.3250	0.3212	0.0230	0.0451	0.0444	0.0435	0.0443	0.0430	0.0371		

Table 12

(p/p₀) FOR MODELS 24 AND 25

SPHERICALLY-BLUNTED DOUBLE CONE

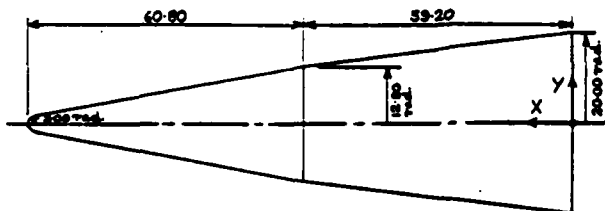

f	3
2r/b	0.099
d/D	0.100
δ	10.35
δ'	6.94
R/D	

C_{0, (δ=0)} = 0.0614

MODEL No.	25	24	25	24	25	24	25	24	25	24	25	24	25	24
X	118.87	118.32	112.84	101.89	79.99	74.51	66.30	63.56	60.83	57.53	49.31	32.87	20.55	8.22
Y	1.90	2.00	3.00	5.00	9.00	10.00	11.50	12.00	12.50	13.00	14.00	16.00	17.50	19.00

α = 0° 0.0552 0.0422 0.0293 0.0401 0.0415 0.0444 0.0419 0.0418 0.0408 0.0333 0.0334 0.0333 0.0339 0.0340

α =	2.5°	5°	7.5°	10°	12.5°	15°	17.5°	20°	22.5°	25°	27.5°	30°	32.5°	35°	37.5°	40°	42.5°	45°	47.5°	50°	52.5°	55°	57.5°	60°	62.5°	65°	67.5°	70°	72.5°	75°	77.5°	80°	82.5°	85°	87.5°	90°
β =	2.5°	5°	7.5°	10°	12.5°	15°	17.5°	20°	22.5°	25°	27.5°	30°	32.5°	35°	37.5°	40°	42.5°	45°	47.5°	50°	52.5°	55°	57.5°	60°	62.5°	65°	67.5°	70°	72.5°	75°	77.5°	80°	82.5°	85°	87.5°	90°
γ =	2.5°	5°	7.5°	10°	12.5°	15°	17.5°	20°	22.5°	25°	27.5°	30°	32.5°	35°	37.5°	40°	42.5°	45°	47.5°	50°	52.5°	55°	57.5°	60°	62.5°	65°	67.5°	70°	72.5°	75°	77.5°	80°	82.5°	85°	87.5°	90°

Table 13

(p/p₀) FOR MODELS 26 AND 27

SPHERICALLY-BLUNTED DOUBLE CONE

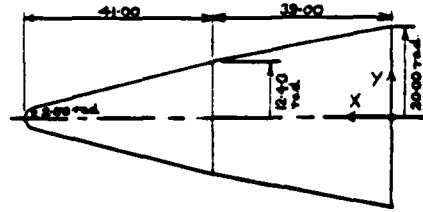

f	2
2r/b	0.121
d/D	0.125
δ	14.36
δ'	11.01
R/D	

C_{0, (4-δ)} = 0.1232

MODEL No.	26	27	26	27	26	27	26	27	26	27	26	27		
X	79.80	79.60	75.77	67.96	52.33	48.43	42.57	40.61	38.53	35.98	30.84	20.56	12.85	5.14
Y	1.00	2.23	3.00	5.00	9.00	10.00	11.50	12.00	12.50	13.00	14.00	16.00	17.50	19.00

α = 0° 0.3014 0.0734 0.0503 0.0504 0.0524 0.0522 0.0530 0.0518 0.0486 0.0443 0.0431 0.0420 0.0429 0.0442

α	11.1°	9.2°	14.6°	23.0°	1.7°	3.7°	21.0°	15.6°	11.1°	16.6°	8.2°	2.7°	24.0°	23.0°
2.5°	0.2980	0.0653	0.0444	0.0445	0.044	0.0461	0.0470	0.0465	0.0433	0.0391	0.0370	0.0370	0.0375	0.0391
5°	0.2980	0.0574	0.0400	0.0400	0.0415	0.0411	0.0428	0.0417	0.0387	0.0349	0.0348	0.0333	0.0343	0.0354
7.5°	0.2861	0.0513	0.0383	0.0385	0.0387	0.0384	0.0382	0.0378	0.0350	0.0317	0.0314	0.0305	0.0308	0.0318
10°	0.2769	0.0455	0.0363	0.0372	0.0361	0.0361	0.0364	0.0367	0.0320	0.0289	0.0287	0.0279	0.0278	0.0285
12.5°	0.2622	0.0406	0.0283	0.0299	0.0318	0.0318	0.0328	0.0317	0.0295	0.0261	0.0261	0.0250	0.0254	0.0254
15°	0.2526	0.0352	0.0253	0.0271	0.0302	0.0299	0.0279	0.0293	0.0272	0.0238	0.0244	0.0227	0.0226	0.0226
17.5°	0.2431	0.0311	0.0227	0.0249	0.0281	0.0281	0.0253	0.0271	0.0251	0.0217	0.0224	0.0207	0.0203	0.0203
θ	40.3°	42.3°	34.9°	28.4°	49.7°	47.7°	30.4°	35.9°	40.3°	34.9°	43.3°	48.7°	27.4°	28.4°
2.5°	0.2985	0.0690	0.0457	0.0455	0.0482	0.0478	0.0473	0.0463	0.0449	0.0402	0.0384	0.0389	0.0394	0.0398
5°	0.2918	0.0632	0.0413	0.0410	0.0438	0.0433	0.0422	0.0415	0.0412	0.0364	0.0358	0.0353	0.0353	0.0359
7.5°	0.2850	0.0564	0.0373	0.0371	0.0399	0.0391	0.0384	0.0384	0.0368	0.0324	0.0316	0.0316	0.0316	0.0324
10°	0.2781	0.0515	0.0344	0.0344	0.0369	0.0369	0.0367	0.0363	0.0323	0.0287	0.0279	0.0278	0.0278	0.0288
12.5°	0.2691	0.0469	0.0309	0.0302	0.0328	0.0328	0.0320	0.0321	0.0287	0.0249	0.0239	0.0235	0.0235	0.0238
15°	0.2617	0.0431	0.0280	0.0274	0.0299	0.0291	0.0281	0.0282	0.0247	0.0212	0.0201	0.0198	0.0198	0.0202
17.5°	0.2526	0.0389	0.0251	0.0246	0.0274	0.0274	0.0271	0.0267	0.0237	0.0201	0.0189	0.0189	0.0189	0.0193
θ	62.5°	60.6°	66.0°	74.4°	53.2°	55.1°	72.4°	67.0°	62.5°	68.0°	59.4°	54.2°	75.4°	74.4°
2.5°	0.0687	0.0477	0.0490	0.0485	0.0483	0.0483	0.0526	0.0526	0.0410	0.0408	0.0390	0.0412	0.0438	0.0438
5°	0.0656	0.0456	0.0449	0.0446	0.0445	0.0445	0.0474	0.0474	0.0385	0.0383	0.0358	0.0386	0.0415	0.0415
7.5°	0.0644	0.0444	0.0440	0.0441	0.0441	0.0441	0.0439	0.0439	0.0363	0.0363	0.0320	0.0320	0.0326	0.0326
10°	0.0531	0.0411	0.0419	0.0412	0.0413	0.0413	0.0399	0.0399	0.0331	0.0306	0.0280	0.0282	0.0282	0.0282
12.5°	0.0531	0.0392	0.0396	0.0311	0.0311	0.0311	0.0351	0.0351	0.0296	0.0265	0.0233	0.0232	0.0232	0.0231
15°	0.0501	0.0374	0.0372	0.0259	0.0259	0.0259	0.0308	0.0308	0.0263	0.0224	0.0189	0.0189	0.0189	0.0189
17.5°	0.0440	0.0350	0.0348	0.0201	0.0212	0.0212	0.0274	0.0274	0.0239	0.0190	0.0148	0.0148	0.0148	0.0148
θ	31.7°	33.7°	38.3°	79.9°	101.1°	93.2°	81.9°	87.3°	91.7°	86.3°	94.7°	100.1°	38.9°	39.9°
2.5°	0.3010	0.0753	0.0509	0.0487	0.0530	0.0540	0.0513	0.0507	0.0505	0.0442	0.0420	0.0432	0.0423	0.0443
5°	0.3003	0.0710	0.0501	0.0474	0.0533	0.0541	0.0518	0.0518	0.0512	0.0436	0.0433	0.0441	0.0428	0.0437
7.5°	0.2933	0.0665	0.0495	0.0458	0.0530	0.0543	0.0513	0.0491	0.0480	0.0419	0.0427	0.0444	0.0384	0.0389
10°	0.2937	0.0629	0.0485	0.0438	0.0513	0.0539	0.0491	0.0470	0.0476	0.0403	0.0421	0.0445	0.0353	0.0371
12.5°	0.2923	0.0579	0.0485	0.0412	0.0516	0.0533	0.0481	0.0458	0.0444	0.0384	0.0416	0.0448	0.0323	0.0340
15°	0.2876	0.0530	0.0473	0.0389	0.0511	0.0529	0.0468	0.0449	0.0438	0.0370	0.0408	0.0430	0.0306	0.0314
17.5°	0.2812	0.0477	0.0448	0.0365	0.0517	0.0528	0.0436	0.0428	0.0419	0.0357	0.0404	0.0425	0.0284	0.0292
θ	114.0°	112.0°	117.4°	125.9°	104.6°	106.4°	123.9°	118.4°	114.0°	119.4°	111.0°	105.6°	124.9°	125.9°
2.5°	0.3046	0.0749	0.0530	0.0530	0.0539	0.0539	0.0578	0.0578	0.0520	0.0471	0.0450	0.0472	0.0441	0.0480
5°	0.3057	0.0717	0.0512	0.0492	0.0539	0.0538	0.0519	0.0512	0.0519	0.0500	0.0465	0.0443	0.0491	0.0516
7.5°	0.3067	0.0682	0.0493	0.0472	0.0532	0.0531	0.0513	0.0513	0.0500	0.0479	0.0447	0.0451	0.0457	0.0465
10°	0.3054	0.0633	0.0483	0.0463	0.0534	0.0534	0.0515	0.0515	0.0500	0.0479	0.0447	0.0451	0.0457	0.0465
12.5°	0.3038	0.0583	0.0474	0.0454	0.0535	0.0535	0.0516	0.0516	0.0500	0.0479	0.0447	0.0451	0.0457	0.0465
15°	0.2990	0.0539	0.0465	0.0445	0.0536	0.0536	0.0517	0.0517	0.0500	0.0479	0.0447	0.0451	0.0457	0.0465
17.5°	0.2955	0.0489	0.0460	0.0440	0.0537	0.0537	0.0518	0.0518	0.0500	0.0479	0.0447	0.0451	0.0457	0.0465
θ	143.2°	145.1°	139.7°	131.3°	152.4°	150.4°	133.3°	138.7°	143.2°	137.7°	146.1°	151.6°	130.7°	131.3°
2.5°	0.3053	0.0797	0.0553	0.0550	0.0598	0.0578	0.0580	0.0580	0.0580	0.0487	0.0473	0.0476	0.0443	0.0478
5°	0.3082	0.0763	0.0542	0.0538	0.0599	0.0579	0.0580	0.0580	0.0580	0.0532	0.0528	0.0538	0.0499	0.0519
7.5°	0.3117	0.0734	0.0533	0.0533	0.0599	0.0579	0.0580	0.0580	0.0580	0.0532	0.0528	0.0538	0.0499	0.0519
10°	0.3108	0.0699	0.0524	0.0524	0.0599	0.0579	0.0580	0.0580	0.0580	0.0532	0.0528	0.0538	0.0499	0.0519
12.5°	0.3142	0.0659	0.0515	0.0515	0.0599	0.0579	0.0580	0.0580	0.0580	0.0532	0.0528	0.0538	0.0499	0.0519
15°	0.3164	0.0619	0.0506	0.0506	0.0599	0.0579	0.0580	0.0580	0.0580	0.0532	0.0528	0.0538	0.0499	0.0519
17.5°	0.3157	0.0579	0.0497	0.0497	0.0599	0.0579	0.0580	0.0580	0.0580	0.0532	0.0528	0.0538	0.0499	0.0519
θ	165.4°	163.4°	168.9°	177.3°	154.0°	158.0°	135.3°	149.9°	145.4°	170.9°	162.4°	157.0°	138.3°	177.3°
2.5°	0.3081	0.0807	0.0560	0.0560	0.0618	0.0577	0.0605	0.0585	0.0570	0.0505	0.0491	0.0499	0.0507	0.0507
5°	0.3133	0.0781	0.0549	0.0549	0.0618	0.0618	0.0630	0.0630	0.0631	0.0574	0.0561	0.0564	0.0573	0.0573
7.5°	0.3175	0.0763	0.0536	0.0536	0.0618	0.0618	0.0630	0.0630	0.0631	0.0574	0.0561	0.0564	0.0573	0.0573
10°	0.3166	0.0744	0.0525	0.0525	0.0618	0.0618	0.0630	0.0630	0.0631	0.0574	0.0561	0.0564	0.0573	0.0573
12.5°	0.3199	0.0724	0.0514	0.0514	0.0618	0.0618	0.0630	0.0630	0.0631	0.0574	0.0561	0.0564	0.0573	0.0573
15°	0.3229	0.0704	0.0503	0.0503	0.0618	0.0618	0.0630	0.0630	0.0631	0.0574	0.0561	0.0564	0.0573	0.0573
17.5°	0.3234	0.0684	0.0492	0.0492	0.0618	0.0618	0.0630	0.0630	0.0631	0.0574	0.0561	0.0564	0.0573	0.0573

Table 14
(p/p₀) FOR MODELS 28 AND 29

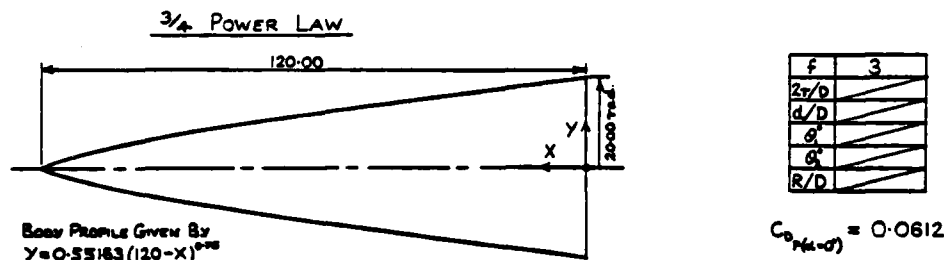

MODEL No.	29	28	29	28	29	28	29	28	29	28	29	28	29	28
X	117.79	114.43	110.44	101.10	78.62	72.38	62.62	59.27	53.98	52.43	45.42	30.88	19.57	7.93
Y	1.00	2.00	3.00	5.00	9.00	10.00	11.50	12.00	12.50	13.00	14.00	16.00	17.50	19.00

$\alpha = 0^\circ$	0.0458	0.0540	0.0508	0.0441	0.0403	0.0380	0.0366	0.0372	0.0368	0.0363	0.0359	0.0349	0.0359	0.0351
--------------------	--------	--------	--------	--------	--------	--------	--------	--------	--------	--------	--------	--------	--------	--------

$\alpha = 2.5^\circ$	0.0581	0.0472	0.0393	0.0343	0.0340	0.0332	0.0332	0.0328	0.0329	0.0318	0.0314	0.0314	0.0314	0.0314
5	0.0534	0.0431	0.0353	0.0327	0.0318	0.0304	0.0312	0.0307	0.0302	0.0290	0.0287	0.0287	0.0287	0.0287
7.5	0.0477	0.0386	0.0314	0.0300	0.0289	0.0280	0.0284	0.0282	0.0280	0.0268	0.0264	0.0264	0.0264	0.0264
10	0.0432	0.0351	0.0280	0.0278	0.0266	0.0261	0.0263	0.0263	0.0260	0.0248	0.0244	0.0244	0.0244	0.0244
12.5	0.0389	0.0317	0.0252	0.0253	0.0247	0.0244	0.0242	0.0245	0.0243	0.0232	0.0228	0.0228	0.0228	0.0228
15	0.0357	0.0290	0.0229	0.0238	0.0231	0.0227	0.0217	0.0228	0.0225	0.0217	0.0217	0.0217	0.0217	0.0217
17.5	0.0337	0.0279	0.0183	0.0212	0.0193	0.0211	0.0184	0.0216	0.0205	0.0210	0.0210	0.0210	0.0210	0.0210
$\alpha = 2.5^\circ$	48.8	42.3	28.4	34.8	35.7	38.9	47.7	41.3	34.8	47.7	42.3	29.5	28.4	28.4
5	0.0601	0.0487	0.0389	0.0341	0.0348	0.0341	0.0349	0.0339	0.0339	0.0333	0.0316	0.0316	0.0316	0.0316
7.5	0.0551	0.0457	0.0360	0.0329	0.0315	0.0311	0.0315	0.0306	0.0308	0.0298	0.0290	0.0290	0.0290	0.0290
10	0.0515	0.0411	0.0320	0.0292	0.0281	0.0276	0.0281	0.0272	0.0273	0.0267	0.0253	0.0253	0.0253	0.0253
12.5	0.0482	0.0369	0.0281	0.0256	0.0247	0.0239	0.0245	0.0241	0.0235	0.0231	0.0228	0.0228	0.0228	0.0228
15	0.0452	0.0321	0.0241	0.0219	0.0210	0.0203	0.0207	0.0210	0.0200	0.0190	0.0216	0.0216	0.0216	0.0216
17.5	0.0432	0.0294	0.0182	0.0213	0.0193	0.0213	0.0188	0.0213	0.0201	0.0214	0.0214	0.0214	0.0214	0.0214
$\alpha = 2.5^\circ$	54.1	46.5	34.5	48.0	47.0	47.0	55.2	46.6	48.0	55.2	46.5	34.5	34.5	34.5
5	0.0603	0.0484	0.0384	0.0349	0.0348	0.0343	0.0357	0.0349	0.0348	0.0339	0.0314	0.0314	0.0314	0.0314
7.5	0.0558	0.0446	0.0353	0.0322	0.0311	0.0303	0.0309	0.0301	0.0302	0.0291	0.0282	0.0282	0.0282	0.0282
10	0.0528	0.0429	0.0347	0.0323	0.0311	0.0303	0.0309	0.0299	0.0299	0.0288	0.0279	0.0279	0.0279	0.0279
12.5	0.0494	0.0397	0.0320	0.0295	0.0283	0.0275	0.0281	0.0271	0.0271	0.0260	0.0251	0.0251	0.0251	0.0251
15	0.0461	0.0333	0.0257	0.0246	0.0238	0.0230	0.0236	0.0226	0.0226	0.0214	0.0217	0.0217	0.0217	0.0217
17.5	0.0436	0.0298	0.0228	0.0219	0.0211	0.0203	0.0209	0.0200	0.0200	0.0189	0.0204	0.0204	0.0204	0.0204
$\alpha = 2.5^\circ$	100.2	93.8	79.8	84.3	87.3	87.3	99.1	92.7	84.3	99.1	93.8	80.9	79.8	79.8
5	0.0670	0.0537	0.0480	0.0440	0.0395	0.0384	0.0389	0.0380	0.0381	0.0376	0.0351	0.0339	0.0347	0.0350
7.5	0.0627	0.0513	0.0441	0.0426	0.0388	0.0382	0.0356	0.0365	0.0363	0.0347	0.0344	0.0339	0.0329	0.0327
10	0.0589	0.0498	0.0424	0.0408	0.0368	0.0362	0.0332	0.0342	0.0339	0.0328	0.0320	0.0318	0.0312	0.0316
12.5	0.0552	0.0463	0.0389	0.0374	0.0333	0.0327	0.0297	0.0307	0.0304	0.0293	0.0284	0.0284	0.0273	0.0283
15	0.0522	0.0433	0.0359	0.0344	0.0303	0.0297	0.0267	0.0277	0.0274	0.0263	0.0254	0.0254	0.0243	0.0254
17.5	0.0494	0.0405	0.0331	0.0316	0.0275	0.0269	0.0239	0.0249	0.0246	0.0235	0.0226	0.0226	0.0215	0.0226
$\alpha = 2.5^\circ$	109.5	112.0	123.9	119.5	118.4	118.4	126.6	113.0	119.5	126.6	112.0	124.8	125.9	125.9
5	0.0684	0.0559	0.0533	0.0492	0.0442	0.0412	0.0391	0.0389	0.0378	0.0380	0.0380	0.0380	0.0380	0.0380
7.5	0.0638	0.0527	0.0453	0.0438	0.0398	0.0392	0.0362	0.0371	0.0369	0.0358	0.0351	0.0351	0.0341	0.0348
10	0.0599	0.0508	0.0434	0.0419	0.0379	0.0373	0.0343	0.0352	0.0350	0.0339	0.0330	0.0330	0.0320	0.0327
12.5	0.0561	0.0470	0.0396	0.0381	0.0341	0.0335	0.0305	0.0314	0.0312	0.0301	0.0292	0.0292	0.0282	0.0291
15	0.0529	0.0438	0.0364	0.0349	0.0309	0.0303	0.0273	0.0282	0.0280	0.0269	0.0260	0.0260	0.0250	0.0259
17.5	0.0497	0.0406	0.0332	0.0317	0.0277	0.0271	0.0241	0.0250	0.0248	0.0237	0.0228	0.0228	0.0218	0.0227
$\alpha = 2.5^\circ$	151.6	145.2	131.3	137.7	138.8	138.8	150.5	144.1	137.7	150.5	145.2	132.3	131.3	131.3
5	0.0732	0.0617	0.0543	0.0528	0.0488	0.0472	0.0442	0.0440	0.0439	0.0428	0.0419	0.0419	0.0419	0.0419
7.5	0.0687	0.0572	0.0498	0.0483	0.0443	0.0437	0.0407	0.0416	0.0414	0.0403	0.0394	0.0394	0.0384	0.0391
10	0.0642	0.0527	0.0453	0.0438	0.0398	0.0392	0.0362	0.0371	0.0369	0.0358	0.0351	0.0351	0.0341	0.0348
12.5	0.0603	0.0488	0.0414	0.0399	0.0359	0.0353	0.0323	0.0332	0.0330	0.0319	0.0310	0.0310	0.0300	0.0307
15	0.0564	0.0449	0.0375	0.0360	0.0320	0.0314	0.0284	0.0293	0.0291	0.0280	0.0271	0.0271	0.0261	0.0269
17.5	0.0525	0.0410	0.0336	0.0321	0.0281	0.0275	0.0245	0.0254	0.0252	0.0241	0.0232	0.0232	0.0222	0.0231
$\alpha = 2.5^\circ$	157.0	162.4	177.3	170.9	169.8	169.8	184.0	164.5	170.9	184.0	162.4	173.4	177.3	177.3
5	0.0810	0.0695	0.0621	0.0606	0.0566	0.0550	0.0520	0.0519	0.0518	0.0507	0.0498	0.0498	0.0498	0.0498
7.5	0.0765	0.0650	0.0576	0.0561	0.0521	0.0515	0.0485	0.0494	0.0492	0.0481	0.0472	0.0472	0.0462	0.0471
10	0.0720	0.0605	0.0531	0.0516	0.0476	0.0470	0.0440	0.0449	0.0447	0.0436	0.0427	0.0427	0.0417	0.0426
12.5	0.0675	0.0560	0.0486	0.0471	0.0431	0.0425	0.0395	0.0404	0.0402	0.0391	0.0382	0.0382	0.0372	0.0381
15	0.0630	0.0515	0.0441	0.0426	0.0386	0.0380	0.0350	0.0359	0.0357	0.0346	0.0337	0.0337	0.0327	0.0336
17.5	0.0585	0.0470	0.0396	0.0381	0.0341	0.0335	0.0305	0.0314	0.0312	0.0301	0.0292	0.0292	0.0282	0.0291
$\alpha = 2.5^\circ$	162.4	162.4	177.3	170.9	169.8	169.8	184.0	164.5	170.9	184.0	162.4	173.4	177.3	177.3
5	0.0810	0.0695	0.0621	0.0606	0.0566	0.0550	0.0520	0.0519	0.0518	0.0507	0.0498	0.0498	0.0498	0.0498
7.5	0.0765	0.0650	0.0576	0.0561	0.0521	0.0515	0.0485	0.0494	0.0492	0.0481	0.0472	0.0472	0.0462	0.0471
10	0.0720	0.0605	0.0531	0.0516	0.0476	0.0470	0.0440	0.0449	0.0447	0.0436	0.0427	0.0427	0.0417	0.0426
12.5	0.0675	0.0560	0.0486	0.0471	0.0431	0.0425	0.0395	0.0404	0.0402	0.0391	0.0382	0.0382	0.0372	0.0381
15	0.0630	0.0515	0.0441	0.0426	0.0386	0.0380	0.0350	0.0359	0.0357	0.0346	0.0337	0.0337	0.0327	0.0336
17.5	0.0585	0.0470	0.0396	0.0381	0.0341	0.0335	0.0305	0.0314	0.0312	0.0301	0.0292	0.0292	0.0282	0.0291

Table 15

(p/p_0) FOR MODELS 30 AND 31

3/4 POWER LAW

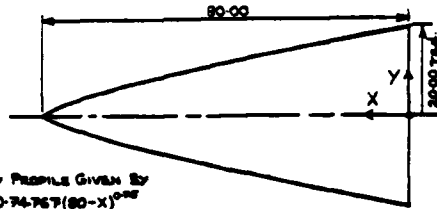

BODY PROFILE GIVEN BY
 $Y = 0.74767(80-X)^{3/4}$

F	2
2r/D	
d/D	
g	
g'	
R/D	

$C_{D_{(M=0)}} = 0.1226$

MODEL No.	30	31	30	31	30	31	30	31	30	31	30	31	30	31
X	78.57	75.66	73.62	67.40	52.41	48.25	41.75	39.52	37.25	34.96	30.28	28.59	18.05	5.29
Y	1.00	2.25	3.00	5.00	9.00	10.00	11.50	12.00	12.50	13.00	14.00	16.00	17.50	19.00

$\alpha = 0^\circ$	0.1172	0.0786	0.0717	0.0532	0.0310	0.0428	0.0471	0.0469	0.0462	0.0467	0.0454	0.0442	0.0434	0.0431
--------------------	--------	--------	--------	--------	--------	--------	--------	--------	--------	--------	--------	--------	--------	--------

$\alpha =$	θ	15.5°	10.2°	10.2°	22.0°	2.7°	2.7°	16.6°	16.6°	15.5°	15.5°	3.8°	3.8°	23.0°	22.0°
2.5°	0.1037	0.0687	0.0635	0.0524	0.0454	0.0442	0.0417	0.0412	0.0392	0.0415	0.0398	0.0393	0.0389	0.0381	0.0381
5°	0.0921	0.0621	0.0564	0.0445	0.0403	0.0393	0.0374	0.0372	0.0356	0.0372	0.0358	0.0351	0.0347	0.0344	0.0344
7.5°	0.0813	0.0548	0.0496	0.0408	0.0357	0.0350	0.0334	0.0332	0.0320	0.0332	0.0326	0.0315	0.0310	0.0310	0.0310
10°	0.0724	0.0486	0.0440	0.0367	0.0320	0.0317	0.0301	0.0300	0.0290	0.0299	0.0294	0.0287	0.0278	0.0280	0.0280
12.5°	0.0650	0.0431	0.0390	0.0323	0.0284	0.0286	0.0271	0.0273	0.0262	0.0270	0.0267	0.0265	0.0248	0.0252	0.0252
15°	0.0585	0.0382	0.0348	0.0287	0.0253	0.0263	0.0247	0.0249	0.0242	0.0247	0.0248	0.0247	0.0224	0.0229	0.0229
17.5°	0.0520	0.0340	0.0311	0.0254	0.0223	0.0235	0.0223	0.0229	0.0222	0.0226	0.0230	0.0231	0.0199	0.0235	0.0235
θ	33.9°	41.3°	41.3°	29.5°	48.8°	48.8°	34.8°	34.8°	35.9°	35.9°	47.7°	47.7°	28.4°	29.5°	
2.5°	0.1048	0.0720	0.0651	0.0530	0.0471	0.0460	0.0425	0.0421	0.0407	0.0426	0.0418	0.0416	0.0395	0.0399	0.0399
5°	0.0964	0.0656	0.0590	0.0480	0.0433	0.0422	0.0380	0.0380	0.0368	0.0383	0.0383	0.0383	0.0360	0.0364	0.0364
7.5°	0.0883	0.0598	0.0530	0.0421	0.0398	0.0398	0.0342	0.0339	0.0329	0.0342	0.0344	0.0342	0.0325	0.0329	0.0329
10°	0.0824	0.0533	0.0465	0.0352	0.0333	0.0334	0.0276	0.0276	0.0261	0.0271	0.0274	0.0274	0.0253	0.0257	0.0257
12.5°	0.0763	0.0467	0.0403	0.0292	0.0273	0.0273	0.0218	0.0218	0.0203	0.0214	0.0216	0.0216	0.0192	0.0196	0.0196
15°	0.0702	0.0402	0.0339	0.0228	0.0211	0.0211	0.0156	0.0156	0.0141	0.0152	0.0154	0.0154	0.0130	0.0134	0.0134
17.5°	0.0649	0.0337	0.0274	0.0163	0.0147	0.0147	0.0092	0.0092	0.0077	0.0088	0.0090	0.0090	0.0066	0.0070	0.0070
θ	67.0°	61.6°	61.6°	73.4°	54.1°	54.1°	68.0°	68.0°	67.0°	67.0°	55.2°	55.2°	74.5°	73.4°	
2.5°	0.1127	0.0732	0.0670	0.0562	0.0472	0.0463	0.0415	0.0415	0.0403	0.0412	0.0412	0.0412	0.0389	0.0393	0.0393
5°	0.1046	0.0662	0.0608	0.0508	0.0439	0.0424	0.0421	0.0421	0.0407	0.0416	0.0416	0.0416	0.0395	0.0399	0.0399
7.5°	0.0966	0.0601	0.0547	0.0447	0.0399	0.0390	0.0388	0.0388	0.0372	0.0384	0.0384	0.0384	0.0363	0.0367	0.0367
10°	0.0924	0.0533	0.0479	0.0379	0.0331	0.0324	0.0314	0.0314	0.0302	0.0314	0.0314	0.0314	0.0293	0.0297	0.0297
12.5°	0.0858	0.0467	0.0413	0.0313	0.0265	0.0258	0.0248	0.0248	0.0236	0.0248	0.0248	0.0248	0.0227	0.0231	0.0231
15°	0.0792	0.0402	0.0348	0.0248	0.0200	0.0193	0.0183	0.0183	0.0171	0.0183	0.0183	0.0183	0.0162	0.0166	0.0166
17.5°	0.0730	0.0340	0.0286	0.0186	0.0138	0.0131	0.0121	0.0121	0.0109	0.0121	0.0121	0.0121	0.0100	0.0104	0.0104
θ	87.3°	92.7°	92.7°	80.9°	100.7°	100.7°	86.3°	86.3°	87.3°	87.3°	99.1°	99.1°	79.9°	80.9°	
2.5°	0.1170	0.0798	0.0737	0.0586	0.0525	0.0512	0.0474	0.0469	0.0445	0.0459	0.0456	0.0453	0.0444	0.0444	0.0444
5°	0.1177	0.0790	0.0731	0.0563	0.0534	0.0512	0.0451	0.0457	0.0437	0.0448	0.0445	0.0444	0.0419	0.0419	0.0419
7.5°	0.1167	0.0780	0.0721	0.0545	0.0541	0.0517	0.0444	0.0444	0.0424	0.0432	0.0435	0.0432	0.0407	0.0407	0.0407
10°	0.1143	0.0753	0.0694	0.0520	0.0513	0.0485	0.0425	0.0425	0.0408	0.0413	0.0413	0.0413	0.0388	0.0388	0.0388
12.5°	0.1119	0.0745	0.0686	0.0495	0.0487	0.0459	0.0402	0.0402	0.0381	0.0395	0.0395	0.0395	0.0370	0.0370	0.0370
15°	0.1095	0.0734	0.0675	0.0479	0.0471	0.0443	0.0388	0.0388	0.0373	0.0377	0.0377	0.0377	0.0352	0.0352	0.0352
17.5°	0.1061	0.0738	0.0679	0.0463	0.0455	0.0427	0.0372	0.0372	0.0357	0.0361	0.0361	0.0361	0.0336	0.0336	0.0336
θ	118.4°	113.0°	113.0°	124.8°	105.5°	105.5°	119.5°	119.5°	118.4°	118.4°	110.6°	110.6°	125.9°	124.8°	
2.5°	0.1232	0.0815	0.0750	0.0624	0.0529	0.0512	0.0482	0.0486	0.0466	0.0467	0.0466	0.0466	0.0443	0.0443	0.0443
5°	0.1290	0.0837	0.0780	0.0667	0.0543	0.0523	0.0492	0.0496	0.0476	0.0477	0.0476	0.0476	0.0453	0.0453	0.0453
7.5°	0.1352	0.0861	0.0806	0.0722	0.0542	0.0534	0.0504	0.0508	0.0488	0.0489	0.0488	0.0488	0.0465	0.0465	0.0465
10°	0.1401	0.0884	0.0834	0.0767	0.0550	0.0542	0.0512	0.0516	0.0496	0.0497	0.0496	0.0496	0.0473	0.0473	0.0473
12.5°	0.1433	0.0915	0.0869	0.0809	0.0557	0.0558	0.0527	0.0531	0.0511	0.0512	0.0511	0.0511	0.0488	0.0488	0.0488
15°	0.1454	0.0935	0.0891	0.0859	0.0562	0.0563	0.0532	0.0536	0.0516	0.0517	0.0516	0.0516	0.0493	0.0493	0.0493
17.5°	0.1468	0.0944	0.0924	0.0914	0.0565	0.0569	0.0534	0.0538	0.0518	0.0519	0.0518	0.0518	0.0495	0.0495	0.0495
θ	138.8°	144.1°	144.1°	132.3°	151.6°	151.6°	137.7°	137.7°	138.8°	138.8°	150.5°	150.5°	131.3°	132.3°	
2.5°	0.1274	0.0844	0.0789	0.0644	0.0539	0.0529	0.0496	0.0496	0.0476	0.0477	0.0476	0.0476	0.0453	0.0453	0.0453
5°	0.1385	0.0935	0.0881	0.0701	0.0563	0.0562	0.0531	0.0531	0.0511	0.0512	0.0511	0.0511	0.0488	0.0488	0.0488
7.5°	0.1489	0.1013	0.0923	0.0745	0.0598	0.0597	0.0566	0.0566	0.0546	0.0547	0.0546	0.0546	0.0523	0.0523	0.0523
10°	0.1573	0.1101	0.1000	0.0796	0.0597	0.0597	0.0566	0.0566	0.0546	0.0547	0.0546	0.0546	0.0523	0.0523	0.0523
12.5°	0.1657	0.1203	0.1083	0.0855	0.0645	0.0645	0.0614	0.0614	0.0594	0.0595	0.0594	0.0594	0.0571	0.0571	0.0571
15°	0.1732	0.1304	0.1174	0.0915	0.0655	0.0655	0.0624	0.0624	0.0604	0.0605	0.0604	0.0604	0.0581	0.0581	0.0581
17.5°	0.1804	0.1400	0.1273	0.0982	0.0665	0.0665	0.0634	0.0634	0.0614	0.0615	0.0614	0.0614	0.0591	0.0591	0.0591
θ	149.8°	144.5°	144.5°	117.6°	157.0°	157.0°	170.9°	170.9°	149.8°	149.8°	158.0°	158.0°	177.3°	177.3°	
2.5°	0.1294	0.0874	0.0811	0.0645	0.0568	0.0558	0.0540	0.0540	0.0524	0.0523	0.0523	0.0523	0.0500	0.0500	0.0500
5°	0.1439	0.0954	0.0898	0.0732	0.0634	0.0624	0.0608	0.0608	0.0592	0.0591	0.0591	0.0591	0.0568	0.0568	0.0568
7.5°	0.1538	0.1037	0.0985	0.084	0.0711	0.0702	0.0692	0.0692	0.0676	0.0675	0.0675	0.0675	0.0652	0.0652	0.0652
10°	0.1634	0.1119	0.1090	0.094	0.0736	0.0727	0.0717	0.0717	0.0701	0.0700	0.0700	0.0700	0.0677	0.0677	0.0677
12.5°	0.1813	0.1298	0.1208	0.1064	0.0886	0.0874	0.0869	0.0869	0.0853	0.0852	0.0852	0.0852	0.0829	0.0829	0.0829
15°	0.1924	0.1422	0.1324	0.1181	0.0980	0.0966	0.0960	0.0960	0.0944	0.0943	0.0943	0.0943	0.0920	0.0920	0.0920
17.5°	0.2015	0.1500	0.1471	0.1308	0.1080	0.1074	0.1113	0.1113	0.1086	0.1085	0.1085	0.1085	0.1062	0.1062	0.1062

Table 16

(p/p₀) FOR MODELS 32 AND 33 AT ZERO ANGLE OF ATTACK ALONE

SPHERICALLY-BLUNTED TANGENT OGIVE

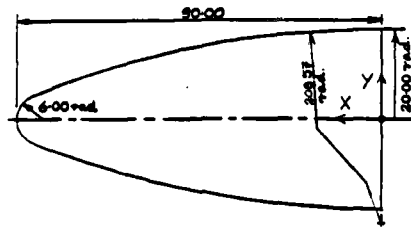

f	2
2r/D	0.279
d/D	0.300
θ'	
θ''	
R/D	5.214

$C_{D_{P(4-\sigma)}} = 0.1625$

MODEL No.	33	32	33	32	33	32	33	32	33	32	33	32	33	32
X	79.54	79.15	77.26	66.79	63.75	58.95	57.16	55.43	53.53	49.66	40.60	32.14	20.28	10.18
Y	2.21	2.96	4.95	8.96	9.94	11.45	11.93	12.44	12.92	13.93	15.95	17.47	18.95	19.73
$\alpha = 0^\circ$	0.2142	0.2131	0.1097	0.0614	0.0608	0.0522	0.0532	0.0548	0.0519	0.0472	0.0418	0.0364	0.0303	0.0259

Table 17.

(p/p₀) FOR MODELS 34 AND 35 AT ZERO ANGLE OF ATTACK ALONE

SPHERICALLY-BLUNTED TANGENT OGIVE

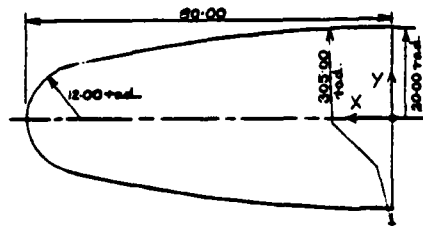

f	2
2r/D	0.584
d/D	0.600
θ'	
θ''	
R/D	7.625

$C_{D_{P(4-\sigma)}} = 0.2920$

MODEL No.	35	34	35	34	35	34	35	34	35	34	35	34	35	34
X	79.75	79.60	78.90	76.03	74.70	71.48	69.44	67.24	65.06	60.25	49.12	38.94	24.69	12.53
Y	2.28	2.96	5.08	8.96	9.97	11.43	11.94	12.40	12.93	13.95	15.97	17.44	18.95	19.73
$\alpha = 0^\circ$	0.2144	0.2155	0.2144	0.1558	0.1084	0.0534	0.0454	0.0448	0.0423	0.0357	0.0327	0.0274	0.0246	

LIST OF SYMBOLS

$C_{Dp}(\alpha=0^\circ)$	forebody pressure drag coefficient at zero angle of attack. Pressure drag/ $(q\pi D^2/4)$
D	maximum body diameter
d	diameter of nose blunting (see Fig 2)
f	forebody fineness ratio L/D
L	overall forebody length
p	surface pressure
P_0	freestream stagnation pressure
q	dynamic pressure
R	radius of tangent ogive profile (see Fig 2)
r	body radius at junction between spherical nose blunting and forebody profile (see Fig 2)
X	axial distance along body centre line (positive upstream)
Y	radial distance of body surface from X axis
α	body angle of attack to freestream
θ_1 and θ_2	angles between conical sections and X axis (see Fig 2)
ϕ	effective pressure hole roll angle. Set in range of 0 to 90 degrees as model and pressure symmetry either side of pitch plane assumed. $\phi = 0$ is most leeward generator on model surface as α increases positively.

REFERENCES

- | <u>No.</u> | <u>Author</u> | <u>Title, etc</u> |
|------------|---------------|--|
| 1 | - | Foredrag of spherically blunted cones in supersonic flow.
Engineering Sciences Data Unit Item 68021 (1968) |
| 2 | - | Forebodies of fineness ratio 1.0, 1.5 and 2.0, having low values of wave drag coefficient at transonic speeds.
Engineering Sciences Data Unit Item 79004 (1979) |
| 3 | - | Axial pressure coefficient distributions for forebodies of fineness ratio 1.0, 1.5 and 2.0 at zero incidence in transonic flow.
Engineering Sciences Data Unit Item 80008 (1980) |
| 4 | - | Pressure drag of blunt forebodies at zero incidence for Mach numbers up to 4.
Engineering Sciences Data Unit Item 80021 (1980) |
| 5 | - | The pressure distribution at zero incidence over selected families of blunt axisymmetric forebodies.
Engineering Sciences Data Unit Item 82018 (1982) |
| 6 | - | Pressure drag of spherically-blunted conical forebodies at zero incidence for Mach numbers of 3 and above.
Engineering Sciences Data Unit Item 82028 (1982) |
| 7 | L.C. Ward | Measurements of pressure distributions and pressure drags at zero incidence on both blunt and sharp axisymmetric forebodies at a Mach number of 3.
ARC Reports and Memoranda No.3849 (1976) |

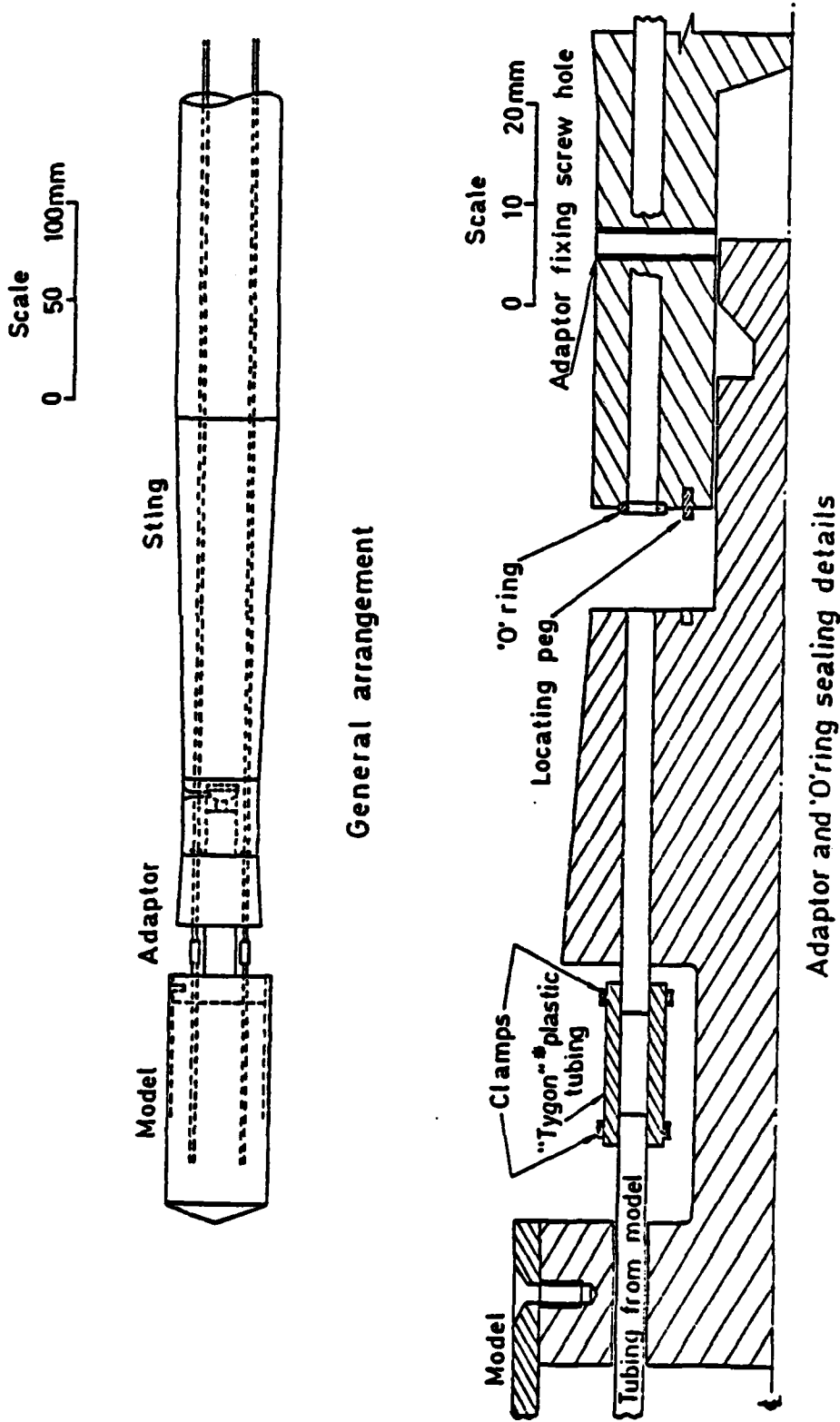

General arrangement

Adaptor and O'ring sealing details

* Proprietary trade name - formulation R3603

Fig 1 General arrangement of model mounting on the wind-tunnel sting, and details of 'O' ring adaptor

Fig 2

Spherically blunted single cone

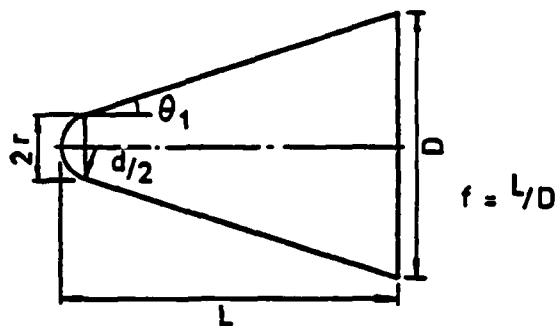

Spherically blunted double cone

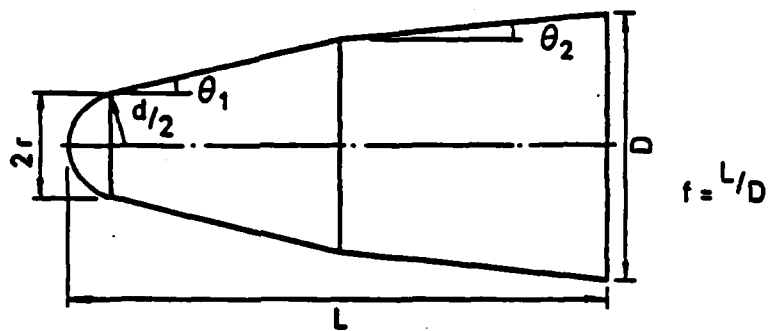

Truncated cone

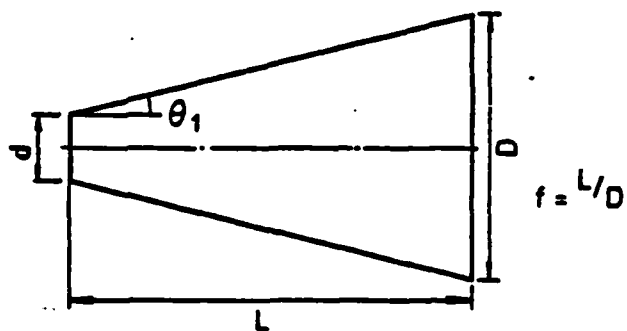

Spherically blunted tangent ogive

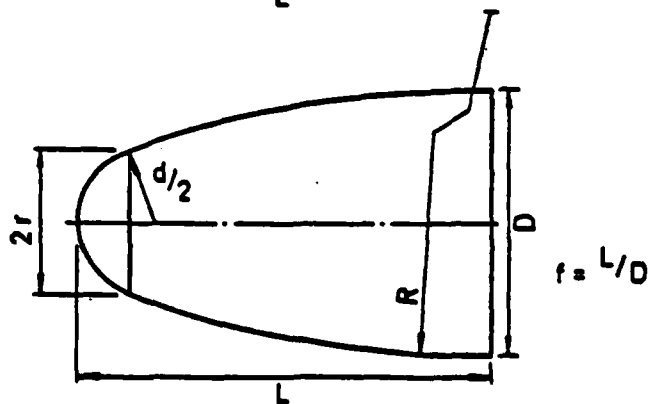

Fig 2 Geometrical nomenclature used for the forebodies. Cylindrical afterbodies are not shown

REPORT DOCUMENTATION PAGE

Overall security classification of this page

UNLIMITED

As far as possible this page should contain only unclassified information. If it is necessary to enter classified information, the box above must be marked to indicate the classification, e.g. Restricted, Confidential or Secret.

1. DRIC Reference (to be added by DRIC)	2. Originator's Reference RAE TM Aero 1985	3. Agency Reference N/A	4. Report Security Classification/Marking UNLIMITED	
5. DRIC Code for Originator 7673000W		6. Originator (Corporate Author) Name and Location Royal Aircraft Establishment, Farnborough, Hants, UK		
5a. Sponsoring Agency's Code N/A		6a. Sponsoring Agency (Contract Authority) Name and Location N/A		
7. Title Experimental pressure distributions on axisymmetric forebodies at Mach 3 and angles of attack up to 17.5 degrees				
7a. (For Translations) Title in Foreign Language				
7b. (For Conference Papers) Title, Place and Date of Conference				
8. Author 1. Surname, Initials Ward, L.C.	9a. Author 2	9b. Authors 3, 4	10. Date November 1983	Pages Refs. 25 7
11. Contract Number N/A	12. Period N/A	13. Project	14. Other Reference Nos.	
15. Distribution statement (a) Controlled by – Head of Aerodynamics Department, RAE (b) Special limitations (if any) –				
16. Descriptors (Keywords) (Descriptors marked * are selected from TEST) Blunt bodies*. Bodies of revolution*. Pressure measurement*. Supersonic flow*.				
17. Abstract Tabulations of experimental surface pressure distributions on both blunt and sharp axisymmetric forebodies are presented for a freestream Mach number of 3.0 and body angles of attack up to 17.5 degrees. The experimental details are described, but no analysis of the resultant data has been undertaken.				

1/0165

END

FILMED

6-84

DTIC