

AD-A140 568

AN IMPROVED MSK GENERATOR DIAGNOSTIC UNIT(U) IIT
RESEARCH INST CHICAGO IL G L NICHOLAS JAN 84
IITRI-E06549-2 N00039-84-C-0070

1/1

UNCLASSIFIED

F/G 14/2

NL

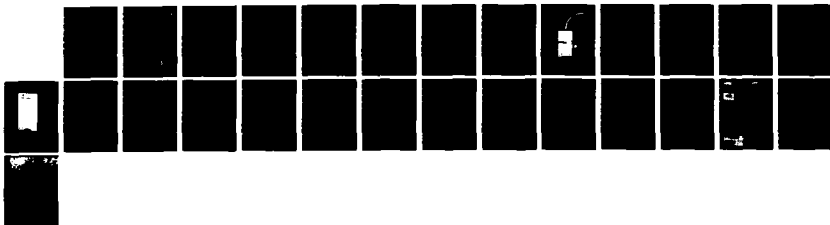

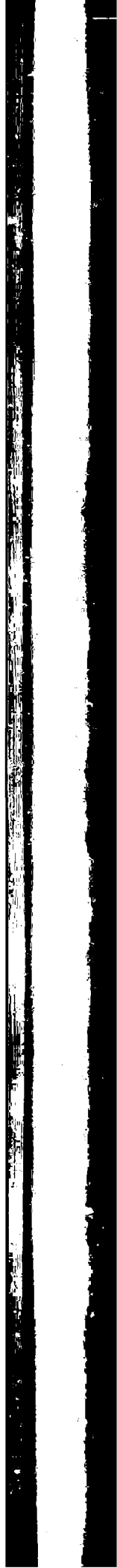

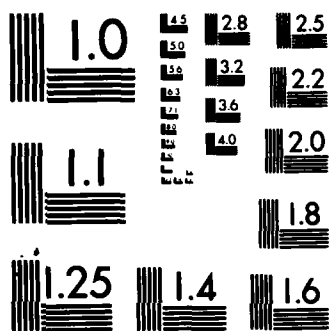

MICROCOPY RESOLUTION TEST CHART
NATIONAL BUREAU OF STANDARDS-1963-A

AD-A140 568

①

IITR

Technical Report E06549-2
Contract No. N00039-84-C-0070

AN IMPROVED MSK GENERATOR DIAGNOSTIC UNIT

G. L. Nicholas

January 1984

Prepared for:

U.S. Naval Electronic Systems Command
Washington, D.C. 20360

DTIC FILE COPY

Submitted by:

IIT Research Institute
10 West 35th Street
Chicago, Illinois 60616

DTIC
ELECTRONIC
S APR 27 1984
A

This document has been approved
for public release and sale; its
distribution is unlimited.

84 04 26 041

Unclassified

SECURITY CLASSIFICATION OF THIS PAGE (When Data Entered)

REPORT DOCUMENTATION PAGE		READ INSTRUCTIONS BEFORE COMPLETING FORM
1. REPORT NUMBER	2. GOVT ACCESSION NO. AD-A140 568	3. RECIPIENT'S CATALOG NUMBER
4. TITLE (and Subtitle) An Improved MSK Generator Diagnostic Unit	5. TYPE OF REPORT & PERIOD COVERED Technical 1983-1984	6. PERFORMING ORG. REPORT NUMBER E06549-2
		8. CONTRACT OR GRANT NUMBER(s) N00039-84-C-0070
7. AUTHOR(s) G.L. Nicholas	9. PERFORMING ORGANIZATION NAME AND ADDRESS IIT Research Institute 10 West 35th Street Chicago, Illinois 60616	10. PROGRAM ELEMENT, PROJECT, TASK AREA & WORK UNIT NUMBERS
11. CONTROLLING OFFICE NAME AND ADDRESS Naval Electronic Systems Command Washington, D.C. 20360	12. REPORT DATE March 1984	15. SECURITY CLASS. (of this report) Unclassified
	13. NUMBER OF PAGES 35	
14. MONITORING AGENCY NAME & ADDRESS (if different from Controlling Office)	16. DISTRIBUTION STATEMENT (of this Report) Unlimited Distribution	
17. DISTRIBUTION STATEMENT (of the abstract entered in Block 20, if different from Report)		
18. SUPPLEMENTARY NOTES		
19. KEY WORDS (Continue on reverse side if necessary and identify by block number) Extremely Low Frequency Test Equipment MSK		
20. ABSTRACT (Continue on reverse side if necessary and identify by block number) The intended use, system design characteristics and operating instructions for a diagnostic unit used with specific MSK Generators are described. The device is intended to allow the MSK Generator user the ability to monitor the output frequency of the generator as well as monitor the several internal frequencies and time intervals on which the output frequency is based. The unit is portable; all power and signal requirements are supplied by the MSK Generator under evaluation.		

DD FORM 1 JAN 73 1473

EDITION OF 1 NOV 65 IS OBSOLETE

Unclassified

SECURITY CLASSIFICATION OF THIS PAGE (When Data Entered)

FOREWORD

The design and methods of use of an improved second generation MSK Generator Diagnostic Unit are presented in this document. The diagnostic unit described herein is designed to remedy the previous unit's shortcomings while maintaining all of its advantages. The main areas of improvement are: ability to measure the actual generated MSK frequency, ability to measure internal time base and VCO frequencies, elimination of internal battery, reduced power consumption, simplified operation and handling, and greatly improved fault isolation techniques.

The design, fabrication, and testing activities were performed by J. R. Gauger and G. L. Nicholas.

Respectfully submitted,
IIT RESEARCH INSTITUTE

G. L. Nicholas
G. L. Nicholas
Assistant Engineer

APPROVED:

R. D. Carlson

R. D. Carlson
Program Manager

A. R. Valentino

A. R. Valentino
Manager, Electromagnetic
and Environmental Effects

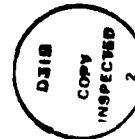

Administrative stamp area with a grid and handwritten initials 'A-1'.

IIT RESEARCH INSTITUTE

CONTENTS

1. INTRODUCTION.....	1
1.1 Background.....	1
1.2 Overview.....	1
2. OPERATION OF THE DIAGNOSTIC UNIT.....	2
2.1 Review of MSK Generator Operation.....	2
2.2 Diagnostic Unit.....	2
2.3 Control Settings.....	4
2.3.1 Function Switch at VCO Setting.....	4
2.3.2 Function Switch at TB Setting.....	4
2.3.3 Function Switch at MSK Setting.....	5
2.3.4 Function Switch at K Setting.....	5
3. MSK GENERATOR SET-UP.....	6
3.1 General Information.....	6
3.2 Initial Set-Up Conditions.....	6
3.3 Generator Testing.....	9
3.4 Optional Diagnostic Testing.....	10
References.....	12
Appendix A. Circuit Description	
Appendix B. Data Sheets	

FIGURES AND TABLES

<u>Figure</u>	<u>Page</u>
1 Diagnostic Unit photograph.....	3
2 MSK Generator face plate.....	8

Tables

1 Typical MSK Generator Settings.....	8
---------------------------------------	---

AN IMPROVED MSK GENERATOR DIAGNOSTIC UNIT

Technical Report E06549-2
Contract No. N00039-84-C-0070

1. INTRODUCTION

1.1 Background

The MSK Generator Diagnostic Unit¹ is a support device for the IITRI designed and built MSK Generator. The MSK Generator fills a need in the ELF biological/ecological test program for a means of generating a signal that emulates the Extremely Low Frequency (ELF) communications system signal, and can do so in a laboratory environment. This signal source must operate properly to ensure the success of the laboratory experiment.

The original method of ensuring proper operation of the MSK Generator required a storage oscilloscope, frequency counter, and AC voltmeter. The first generation MSK Generator Diagnostic Unit eliminated the need for a storage oscilloscope; however, a frequency counter was still needed to ensure that the output frequency was correct. Fault isolation, while enhanced, was still difficult with this first unit.

To remedy these and other shortcomings the second generation MSK Generator Diagnostic Unit was conceived and fabricated. The MSK K counter portion of the original device was retained. The ability to measure the MSK generator output frequency, as well as other critical internal frequencies, was incorporated into the design. Concurrent modifications to the MSK Generators were investigated and implemented.

1.2 Overview

The objective of this report is to describe the modifications to the MSK Generator Diagnostic Unit and to present operating instructions for the resulting improved unit. This device is intended to assist in the initial check-out, set-up, operation, and fault isolation of the MSK Generators.

The improvements in the diagnostic unit include:

- (1) Ability to measure actual MSK Generator output frequency
- (2) Ability to measure the internal time base and VCO frequencies of the MSK Generator

IIT RESEARCH INSTITUTE

- (3) Elimination of internal battery
- (4) Reduced Power consumption
- (5) Simplified operation and handling
- (6) Enhanced MSK Generator fault isolation.

2. OPERATION OF THE DIAGNOSTIC UNIT

2.1 Review of MSK Generator Operation

The characteristics of the MSK signal have been reported previously.² Reviewing briefly, the signal is basically defined by its low frequency, f_l , its high frequency, f_h , and the modulation frequency or chip rate, f_c , the rate at which the signal switches between f_l and f_h . An important feature of the MSK signal is that the number of quarter cycles of the waveform that occurs during a modulation or chip interval is either a unique whole number or an integer multiple of that number. A counter string is used in the MSK Generator to maintain the proper number of quarter cycles in a chip interval.

Section 3.1 of Ref. 2 lists a check-out procedure that is used to verify the proper operation of the counter string. This procedure requires the use of a dual trace storage oscilloscope to view the sum of the MSK output signal and the modulation signal of the MSK Generator. Using this method, the number of quarter cycles in a chip period may be visually counted from the stored trace on the oscilloscope display.

Experience in the field has shown, however, that storage oscilloscopes are frequently difficult to obtain or are often unavailable to perform this check-out at biological research test facilities. The MSK Generator Diagnostic Unit was designed and constructed to solve this problem by eliminating the need for a storage oscilloscope and to aid in the initial set-up, monitoring, general trouble shooting, repair, and maintenance of the MSK Generators.

2.2 Diagnostic Unit

The second generation MSK Generator Diagnostic Unit has been developed with both the operator/laboratory technician and the repair technician in mind. A photograph of the diagnostic unit is shown in Figure 1. This instrument, which is portable and self-contained, may be used in place of a storage

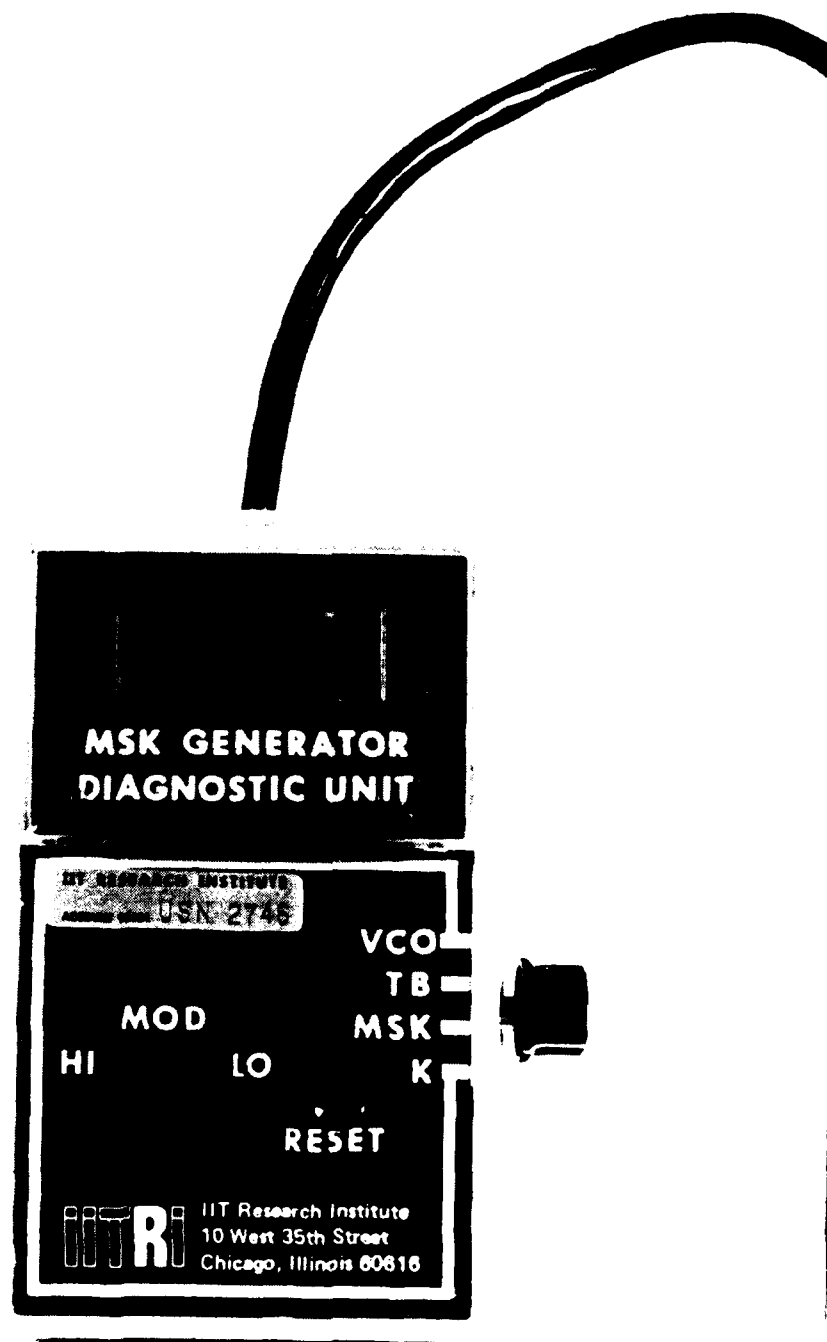

Figure 1. Diagnostic unit photograph.

IIT RESEARCH INSTITUTE

oscilloscope and a frequency counter to perform the operational and periodic check-out of an MSK generator, as well as aid in fault isolation. It connects to the generator via a two-foot long cable, the end of which plugs into the MSK Generator front panel. All power and signal requirements are provided by the MSK Generator under test. The only other device required for the initial MSK Generator set-up and quality monitoring is an RMS AC voltmeter to set the signal output levels. The user-operated portions of the device are two front panel mounted switches and a side mounted function switch. An LCD counter provides the display.

2.3 Control Settings

The following is a brief description of the control settings of the diagnostic unit switches and the resulting display. A complete circuit description can be found in Appendix A of this report.

The function switch located on the right side of the unit is used to select the signal to be measured. There are four positions on this switch, labeled VCO, TB, MSK, and K. These switch positions allow the user to measure the output of the voltage controlled oscillator (VCO), the time base generator (TB), the MSK output frequency (MSK), and the chip interval counter string (K).

2.3.1 Function Switch at VCO Setting

In this position the diagnostic unit measures the frequency of the MSK Generator Voltage Controlled Oscillator. The final output MSK frequency is dependent upon this stage of the generator. The reading obtained on the diagnostic unit display is read directly in kHz and is found by the formula:

$$f_{VCO} = \frac{1024}{N} \times 2(K, K+2) \quad \text{kHz}$$

For this test the MSK Generator Modulation Switch should be in the "HI" (K+2) or "LO" (K) position. The parameters N and K are defined in Section 3.2 below.

2.3.2 Function Switch at TB Setting

In this position the diagnostic unit measures the frequency of the generator's crystal controlled Time Base oscillator. The Time Base oscillator

determines the chip rate of the generator. The indicated frequency is read in Hz and is found by the formula:

$$f_{TB} = \frac{1024 \times 10^3}{N} \quad \text{Hz}$$

2.3.3 Function Switch at MSK Setting

In this position the diagnostic unit measures the MSK Generator output frequency. The output frequency is dependent upon the setting of the MSK generator "N SELECT," "K SELECT," and "MODULATION" switches. The displayed frequency is read in Hz.

Of particular note is the effect of the "MODULATION" switch on this reading. When the "MODULATION" switch is in the "LO" position the MSK frequency produced is the low or space frequency and is found as shown below:

$$f_{out_l} = \frac{1024 \times 10^3}{N} \times \frac{2K}{4 \times 127} \quad \text{Hz}$$

When the "MODULATION" switch is in the "HI" position the frequency produced is the high or mark frequency and is found as shown below:

$$f_{out_h} = \frac{1024 \times 10^3}{N} \times \frac{2(K + 2)}{4 \times 127} \quad \text{Hz}$$

With the MSK "MODULATION" switch in the MSK position:

$$f_{out_{ave}} = \frac{f_{out_l} + f_{out_h}}{2} \quad \text{Hz}$$

2.3.4 Function Switch at K Setting

In this position the diagnostic unit will measure the output of the counter string, which maintains the proper chip interval.

The two switches (MOD & RESET) on the front of the diagnostic unit are used in conjunction with this function switch setting. The results of this

check are dependent upon the MSK Generator "K SELECT" setting. The generator output must be modulated for this test.

With the function switch in the "K" position, place the "MOD" switch to the "LO" setting and press and release the reset switch; the display will indicate the value of the MSK Generator "K SELECT" setting, or an integer multiple of that value (i.e., K or 2K, 3K, etc).

Change the "MOD" switch to the "HI" position; once again press and release the reset switch. The value obtained will be the sum of the "K SELECT" setting plus two, or an integer multiple of that number (i.e., K+2, 2(K+2), 3(K+2), etc.)

3. MSK GENERATOR SET-UP

3.1 General Information

This section describes the utilization of the diagnostic unit with an MSK generator. The steps listed below must be performed:

- when initially activating an MSK Generator
- when any MSK Generator setting is changed
- at periodic intervals to assure proper generator operation.

It is recommended that the readings obtained be recorded along with the date, time, and name of the person making the check.

Table 1 lists examples for several values of "N SELECT" and "K SELECT" settings and the corresponding readouts. Failure of one or more of the below listed tests indicates a generator failure and corrective action should be taken.

3.2 Initial Set-Up Conditions

Figure 2 is a photograph of the MSK Generator face plate. Prior to analyzing the performance of an MSK Generator with the diagnostic unit the following conditions must be met:

- (1) Select a chip and center frequency for use. The values of "N SELECT" and "K SELECT" may be calculated as follows:

TABLE 1. TYPICAL MSK GENERATOR SETTINGS

N SELECT	K SELECT	MODULATION			VCO ¹	TB	MSK ¹	K ²	
		LO	MSK	HI				HI	LO
1008	1 0		X		≈22.35	1015	≈44	12	10
1008	1 0	X			20.31	1015	40	-	-
1008	1 0			X	24.37	1015	48	-	-
1075	1 1		X		≈22.86	952	≈44	13	11
1075	1 1	X			20.94	952	41	-	-
1075	1 1			X	24.75	952	49	-	-
1075	1 9		X		≈38.10	952	≈75	21	19
1075	1 9	X			36.18	952	71	-	-
1075	1 9			X	39.98	952	79	-	-
1008	1 8		X		≈38.60	1015	≈76	20	18
1008	1 8	X			36.55	1015	72	-	-
1008	1 8			X	40.61	1015	80	-	-
2015	3 4		X		≈35.56	508	≈71	36	34
2015	3 4	X			34.54	508	68	-	-
2015	3 4			X	36.57	508	72	-	-
2015	2 4		X		≈25.40	508	≈50	26	24
2015	2 4	X			24.38	508	48	-	-
2015	2 4			X	26.41	508	52	-	-

¹ When the MSK Generator "MODULATION" switch is in the "MSK" position, both the VCO and the MSK output frequencies are shifting between the high and low values at the chip rate and cannot be accurately measured. The value seen on the diagnostic unit display is approximated above.

² Values of "K" (Hi or Lo) can only be obtained when the MSK Generator "MODULATION" switch is in the MSK position.

$$N = \frac{16,125.984}{f_c}$$

$$K = \frac{4f_o}{f_c} - 1$$

where f_c and f_o are the chip and center frequencies in hertz. Some manipulation of f_c and f_o may be necessary to give integer values of "N" and "K." Set these values into the thumbwheel switches on the MSK Generator front panel.

- (2) Plug the MSK Generator into a grounded AC outlet.
- (3) Place the "MODULATION" switch to the "MSK" (center) position.
- (4) Place the "POWER" switch to the "ON" position.

IIT RESEARCH INSTITUTE

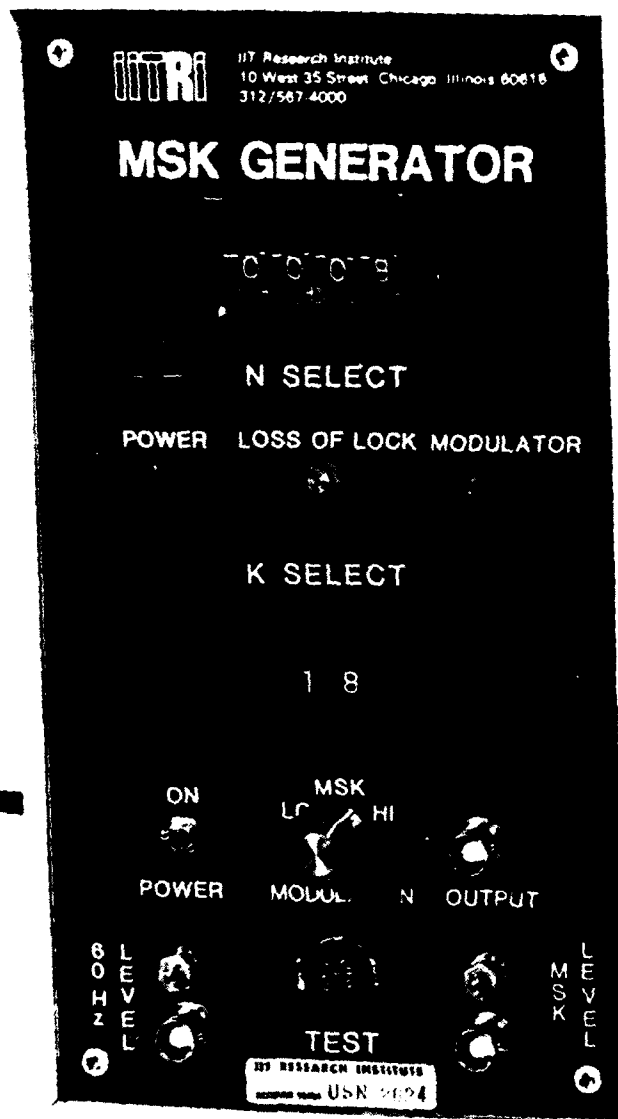

Figure 2. MSK Generator faceplate.

IIT RESEARCH INSTITUTE

(5) Observe that:

- the "POWER" indicator (red) lamp is lighted
- the "LOSS OF LOCK" (yellow) lamp is not lighted
- the "MODULATION" (green) lamp is blinking in a psuedo-random manner.

3.3 Generator Testing

Having met all the above conditions:

- (1) Insert the Diagnostic Unit plug into the "TEST" jack of the MSK Generator. Place the Diagnostic Unit function switch to the "TB" position and observe the time base frequency. Check that the frequency is that expected:

$$f_{TB} = \frac{1024 \times 10^3}{N} \text{ Hz}$$

- (2) Change the Diagnostic Unit function switch to the "MSK" position. Place the MSK Generator "MODULATION" switch to the "LO" position (Note: The "MODULATION" (green) light will not be lighted in this step.) Observe the output space or low frequency:

$$f_{out_l} = f_{TB} \times \frac{2K}{508}$$

- (3) Change the MSK Generator "MODULATION" switch to the "HI" position (Note: the "MODULATION" (green) light will be on while the "MODULATION" switch is in this position). Observe the output mark or high frequency:

$$f_{out_h} = f_{TB} \times \frac{2(K+2)}{508} \text{ Hz}$$

- (4) Place the MSK generator "MODULATION" switch to the "MSK" position (Note: the "MODULATION" (green) light will blink on/off in a psuedorandom manner with the "MODULATION" switch in this position). Observe the output MSK signal frequency:

$$f_{out_{MSK}} = \frac{f_{out_l} + f_{out_h}}{2} \text{ Hz}$$

- (5) Next, change the Diagnostic Unit function switch to the "K" position, and the "MOD" switch to the "LO" setting. Push and release the "RESET" switch; observe the reading, which should be the value of the MSK generator "K SELECT"

IIT RESEARCH INSTITUTE

setting or an integer multiple of that setting (e.g., "K SELECT" set to 13, read 13, 26, 39, etc.).

- (6) Shift the diagnostic unit "MOD" switch to the "HI" position and press and release the "RESET" switch. The value on the display should be that of the "K SELECT" setting plus two (e.g., "K SELECT" set to 13, read 15, 30, 45, etc.).
- (7) Check the adjustment of the signal output. An RMS AC voltmeter is required. Adjustments of both the 60 Hz and MSK signal level are made on the front panel of the MSK Generator. The 60 Hz signal jack (BNC) and level adjustment control are located in the lower left corner of the generator; the MSK on the right. The combined, amplified signals (60 Hz and MSK) are available at the BNC connector labeled "OUTPUT." The combined output is amplified by a factor of 2.2 (e.g., a 1.3 volt level at either the 60 Hz or the MSK signal jack will equal 2.86 volts at the "OUTPUT" connector). Set the signal level at the required level. Caution: The maximum signal level from the MSK Generator is 6.5 volts rms. Signal distortion due to clipping will be experienced if this level is exceeded.

This completes the operational checkout of the MSK Generator. If all the above conditions are met, the unit is ready to use.

3.4 Optional Diagnostic Testing

A final feature of the diagnostic unit is the "VCO" setting of the function switch. Note: this step is only required for fault isolation in the event of a generator failure.

- (1) Set up the MSK Generator and Diagnostic Unit as described in Sections 3.2 and 3.3 (1).
- (2) Place the Diagnostic Unit function switch in the "VCO" position. Place the MSK Generator "MODULATION" switch in the "LO" position; observe that the output frequency on the Diagnostic Unit display is:

$$f_{VCO_L} = \frac{1024}{N} \times 2K \quad \text{kHz}$$

Change the MSK Generator "MODULATION" switch to the "HI" position, observe that the "MODULATION" (green) light is lighted and the output frequency is:

$$f_{VCO_H} = \frac{1024}{N} \times 2(K+2) \quad \text{kHz}$$

IIT RESEARCH INSTITUTE

Place the MSK Generator "MODULATION" switch to the "MSK" position and observe the "MODULATION" (green) light blinking on/off in a pseudorandom manner and that the frequency displayed is:

$$f_{VCO_{MSK}} = \frac{f_{VCO_l} + f_{VCO_h}}{2} \quad \text{kHz}$$

Should any of these conditions not be met refer to Appendix B of Ref. 2.

4. CONCLUSION

In the above, the operation of a new MSK generator diagnostic unit is described. The unit was developed to provide users of Navy MSK Signal generators with a tool for experiment set-up and for periodic monitoring of the function of these generators. Additional details regarding the design of the diagnostic unit are provided in the Appendixes which follow.

REFERENCES

1. J. R. Gauger. "MSK Generator Diagnostic Unit." IITRI Memorandum to PME 117-214, March 1978.
2. V. C. Formanek and J. R. Gauger. Design and Operation of a Minimum Shift Keying (MSK) Signal Generator. IITRI Technical Report E06249-1 (Rev.), May 1977.

APPENDIX A
CIRCUIT DESCRIPTION

IIT RESEARCH INSTITUTE

1. UNIT DESCRIPTION

The MSK Generator Diagnostic Unit is a self-contained, portable device made of one major printed circuit board with seven C/MOS integrated circuits (ICs) and a display unit containing two C/MOS ICs.

Caution: C/MOS circuitry is extremely sensitive to electro-static discharge damage. Steps must be taken to remove all static build-up in the work area and on personnel handling these devices.

The Diagnostic Unit Block Diagram (Figure A-1) outlines five major functional units: a divide by two counter, a divide by 10 counter; a clipper/limiter, the MSK "K" counter and the counter/display device.

2. CIRCUIT OPERATION

Refer to the Diagnostic Unit Schematic Diagram (Figure A-2).and Parts List (Table A-1).

2.1 Counter/Display

The counter/display unit is a prepackaged device with minor IITRI wiring modifications. These modifications provide access to an overflow indicator and a decimal point indicator. Signal conditioning and timing circuits were also required to utilize this device in the diagnostic unit: a divide by two counter stage, a buffer device, and a time base.

(1) Divide by two Counter (IC-4)

The counter/display unit input section was designed to trigger on both the leading and trailing edge of an input signal, hence the inclusion in the Diagnostic Unit of the divide by two counter stage. This counter, which is one half of a 4027 dual J-K flip-flop, is used to halve the signals from the voltage controlled oscillator (VCO), time base (TB), and MSK clipper/limiter so that the proper frequency will be displayed.

(2) Buffer (IC-5)

The counter/display unit requires a 5 volt DC logic level compared to the 12 volt DC logic level of the MSK generator; therefore, a 4050 hex buffer device is used to change the input signal (S-2) and the reset signal (S-1) from the 12 volt logic to a 5 volt logic level.

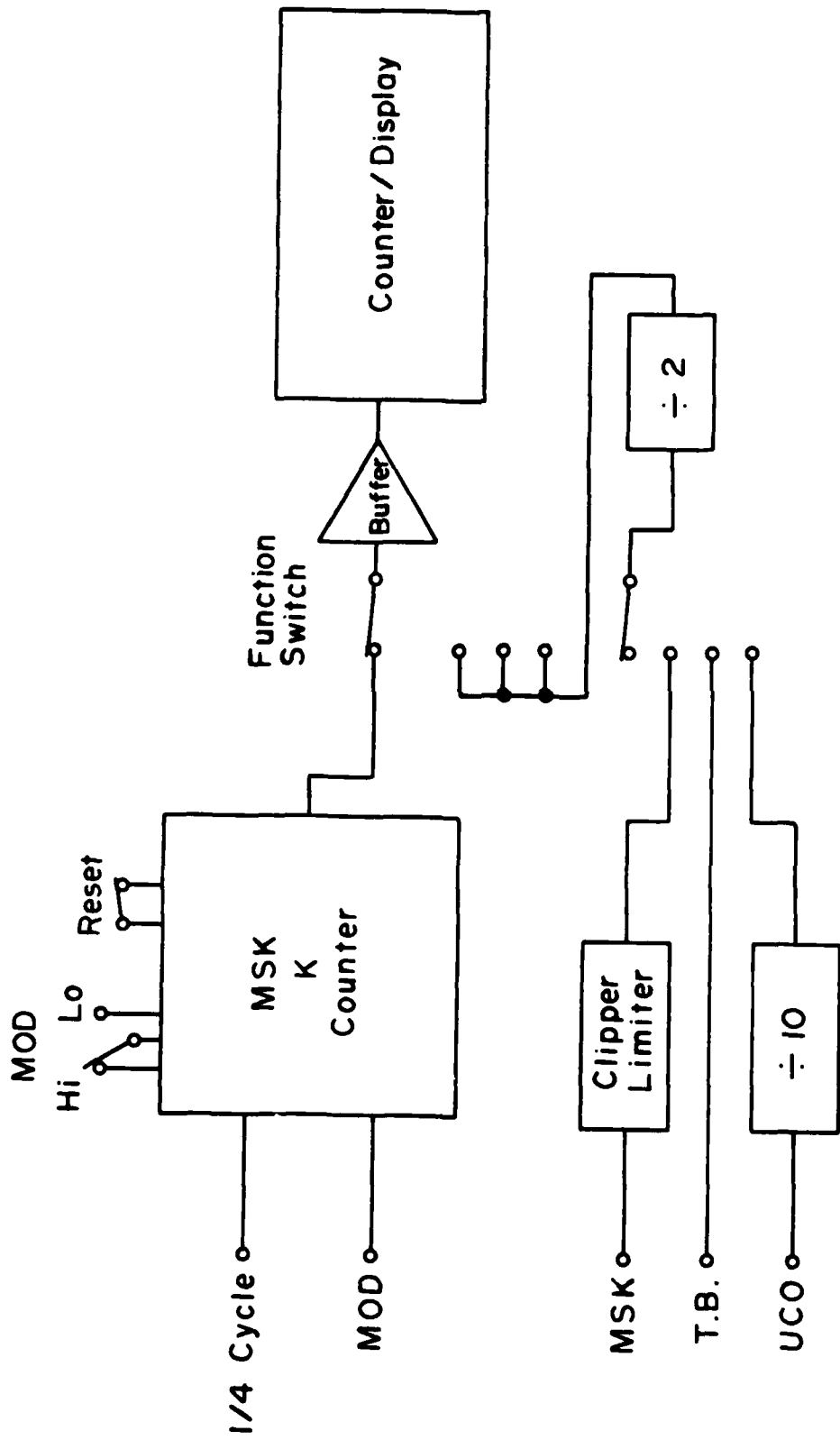

Fig.A1 MSK GENERATOR DIAGNOSTIC UNIT BLOCK DIAGRAM

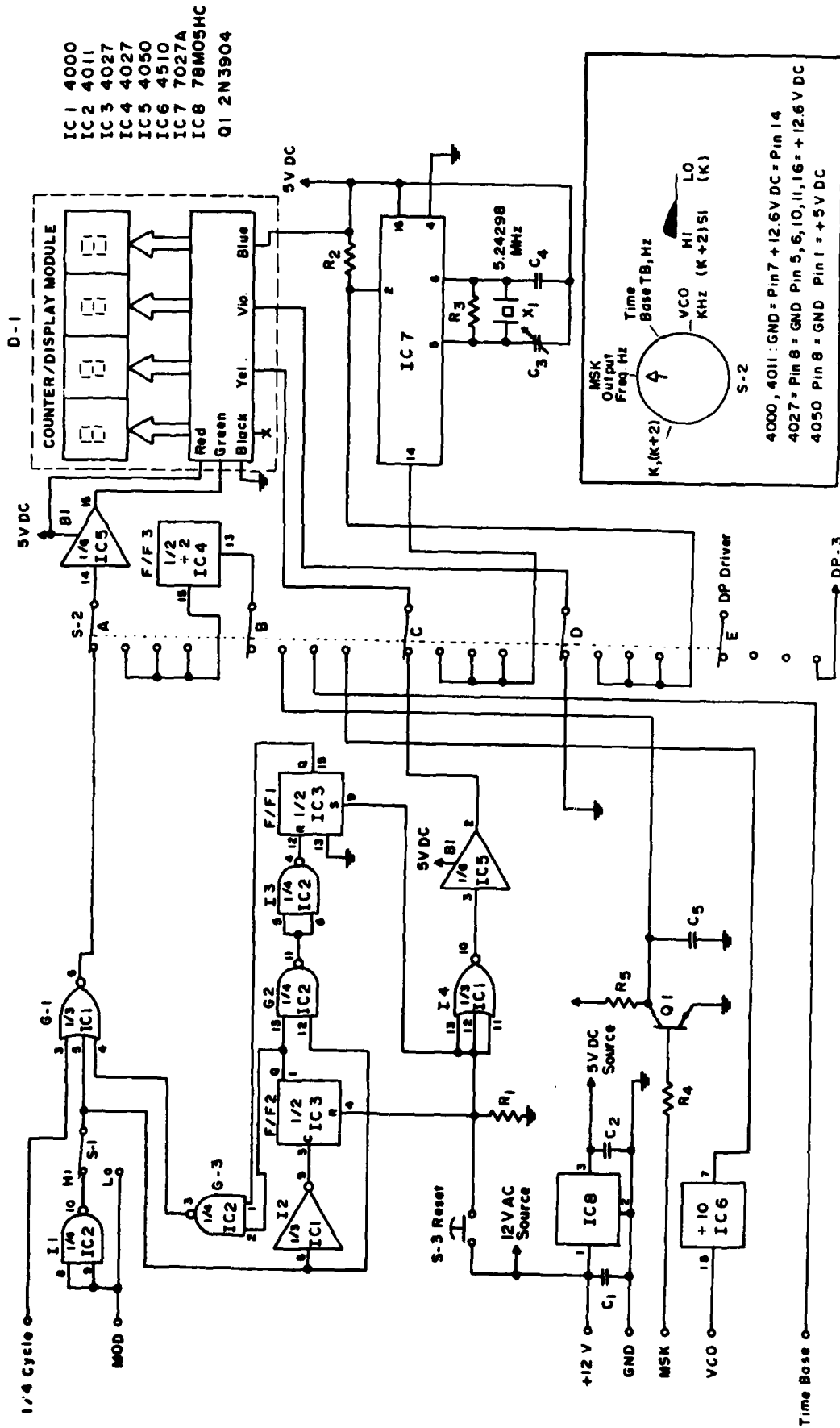

Fig. A2 MSK GENERATOR DIAGNOSTIC UNIT SCHEMATIC DIAGRAM

TABLE A-1. PARTS LIST

Symbol	Manufacturer	Part No.	Description
R-1, R-2 R-4, R-5	A - B	RC05GF1031	10K 10% 1/8 Watt Resistor
R-3	A - B	RC05GF1061	10M 10% 1/8 Watt Resistor
C-1, C-2	Sprague	1500105X9035A21MF350	1 uf 35 VDC
C-3	Erie	538-011D-9-35	9-35 pf Variable Cap
C-4	Sprague	225P10292XD3	22 pfd 35 VDC Capacitor
C-5	Sprague	225P27391WD3	270 pfd 35 VDC Capacitor
D-1	International Microtronics	M522000	Counter Display Module
IC-1	RCA	CD4000UBE	C/MOS Dual 3 Input NOR Gate
IC-2	RCA	CD4011UB	C/MOS Quad 2 Input NAND Gate
IC-3, IC-5	Motorola	MC14027	C/MOS Dual J-K Flip-Flop
IC-4	Motorola	MC14510B	C/MOS BCD Up/ Down Counter
IC-6	Intersil	ICM7207AEU/Kit	Frequency counter time base
IC-7	RCA	CD4050B	C/MOS HEX Buffer
IC-8	Fairchild	78M05HC	5 V 500 mA Regulator
Q-1	Motorola	2N3904	PNP Transistor
S-1	Eaton	MR2-123	SPDT Rocker Switch
S-2	Greyhill	71ASF36-03-2-4N	PC Mount 4 Pole 4 Throw Switch
S-3	Alco	MPS103F-PC	PC Mount Push Button Switch
X-1	Pantec	Crystal 5.24288 MHz Model HP-CT	Part of IC-6 Kit Enclosure

IIT RESEARCH INSTITUTE

(3) Time Base (IC-7)

An ICM 7207A frequency counter time base IC used with a 5.24298 MHz crystal provides the proper reset and strobe signals to enable the display unit to function as a counter.

2.2 Divide by 10 Counter (IC-6)

The divide by 10 counter stage is a single 4510 BCD/up-down frequency counter used to scale the VCO frequency down to the range of the other frequencies (TB and MSK) for the counter/display unit. This down scaling is then offset on the display by the placement of a decimal point in the third DP position to produce a reading in kHz.

2.3 "K" Counter (IC-1,2,83)

The MSK "K" counter stage is made up of three C/MOS ICs, a 4000 dual three input NOR gate (IC-1), a 4011 quad two input NAND gate (IC-2), and a 4027 dual J-K flip-flop (IC-3).

(1) Operation

The "K" counter stage is initialized when the "RESET" switch (S-3) is pressed. This action causes flip-flop f/f2 to be reset with a logic 0 at pin 1 and f/f1 to be set with a logic 1 at pin 15. These opposing levels at pins 1 and 2 of IC-2 (G-3) lock this device to a logic 1 output, which disables the NOR gate (G-1) of the 4000. The first "MOD" pulse into the diagnostic unit toggles f/f2, enabling the NOR gate (G-1), which then passes the string of 1/4 cycle pulses through to the counter/ display. The next MOD pulse reverse toggles f/f2, which in turn toggles f/f1, disabling the NOR gate, G-1, and disabling the flip-flops from further state changes from all following MOD pulses. Pushing and releasing the reset button reinitializes the circuit for another count. The diagnostic unit "MOD" ("HI" or "LO") switch inverts the MOD pulse via I1 of IC-2, enabling a 1/4 cycle count during either the "HI" or "LO" modulator state.

2.4 Voltage Regulator (IC-8)

A 78M05HC voltage regulator and two capacitor filters regulate the 12 VDC provided by the MSK Generator to the 5 VDC level required by the counter/ display unit.

APPENDIX B
DATA SHEETS

IIT RESEARCH INSTITUTE

FLAT PACK LOW POWER 4 DIGIT LCD COUNTER

MODEL 522

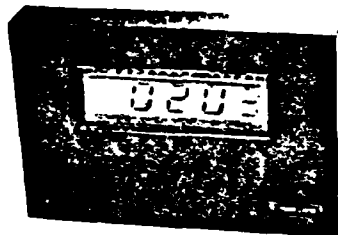

MICRO POWER

FEATURES

- TTL/CMOS Compatible
- 100µA at 5Vdc Power
- High Contrast LCD
- Water Proof Front Panel
- No Panel Cut-Out Required
- Latched Overflow Indication

APPLICATIONS

Low Power, Portable or Remote Applications Such as Counting, Timing, Where Very Low Power and Bright Display in High Ambient Light is Required.

DESCRIPTION

Any counting application where reliability, low power is required in high ambient light environments.

The 522 consists of single LSI chip, an integral 4 digit LCD display and few discrete components.

It increments the count on the negative edge of the pulse, the input has a Schmitt trigger for better noise immunity and it is diode protected.

CONTROL inputs such as reset, count hold, store and leading, zero blanking as well as overflow make it ideal for batch counting, timing, frequency, RPM, etc.

POWER can be from any 5Vdc source capable of supplying 100µA. A9V transistor battery can be used in series with a 3V zener, giving a minimum of 900 hours of uninterrupted operation.

SPECIFICATIONS

- Display 0.35" 9999
- Overflow: Latched and indicated by arrow on MSD
- Power: 5Vdc ± 20% @ 100µA
- Inputs: TTL/CMOS Compatible
- Toggle Rate: 15MHz Minimum
- Operating Temperature: - 10 to + 55°C
- Storage Temperature: - 20 to + 60°C
- Decimal Point: Factory Selected

Note: SEALED UNITS AVAILABLE
IMPORTANT MOUNTING INFORMATION SEE PAGE 29.

CONNECTION COLOR CODE

- RED 5Vdc ± 20%
- BLACK Return and signal common
- GREEN Signal input (-0.3 Vdc. minimum, Vdc maximum)
- YELLOW Reset. Normally open for counting. Connect to BLACK momentarily for reset.
- VIOLET Display hold. Normally connect to BLACK. Open to hold display but continue counting.
- BLUE Counter hold. Normally connected to BLACK. *OPEN* Open to stop count. *BLK*
- ORANGE Leading zero blanking. Normally connected to BLACK. Open to blank out leading zeros.

ORDERING INFORMATION

MODEL 522 X X X

DECIMAL POINT	POWER
0 ... None	0 None (Svd)
1XXXX	1 Open Frame
2 ... X.XXX	2 Power Pack
3 ... XX.XX	
4 ... XXX.X	
	0 Standard
	1 Sealed

See page 29 for Mechanical Information.
Page 26 for XDCRS and page 29 for Power Packs.

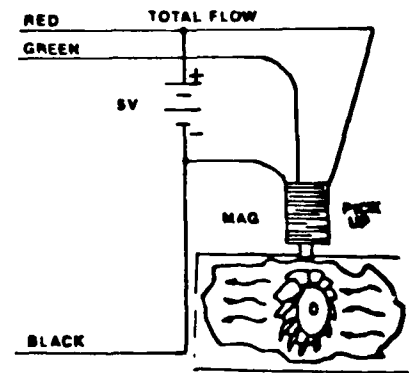
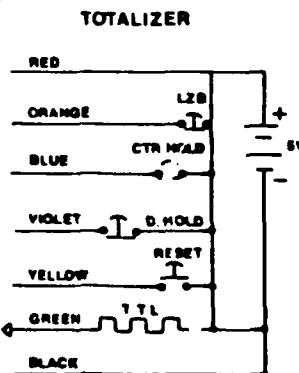
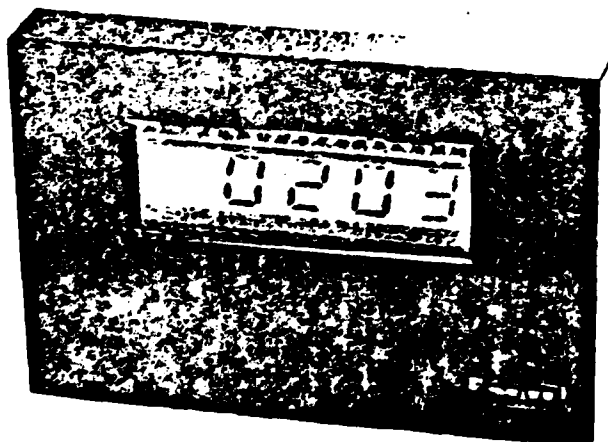

END

FILMED

6-1-54

DTIC





