

12

AD-A140 752



CR 84.019

NAVAL CIVIL ENGINEERING LABORATORY  
Port Hueneme, California

Sponsored by  
NAVAL FACILITIES ENGINEERING COMMAND

**NAVY ELECTROPLATING POLLUTION CONTROL  
TECHNOLOGY ASSESSMENT MANUAL**

February 1984

An Investigation Conducted by  
CENTEC Corporation  
11260 Roger Bacon Drive  
Reston, VA 22090

F08635-81-C-0258

DTIC FILE COPY

DTIC  
ELECTE  
MAY 03 1984  
S D  
E

Approved for public release; distribution is unlimited.

84 04 30 067

METRIC CONVERSION FACTORS

Approximate Conversions to Metric Measures				Approximate Conversions from Metric Measures			
Symbol	When You Know	Multiply by	To Find	Symbol	When You Know	Multiply by	To Find
in ft yd mi	inches feet yards miles	LENGTH *2.5 30 0.9 1.6	centimeters	mm	millimeters	0.04	inches
			centimeters	cm	centimeters	0.4	inches
			meters	m	meters	3.3	feet
			kilometers	km	meters	1.1	yards
in <sup>2</sup> ft <sup>2</sup> yd <sup>2</sup> mi <sup>2</sup>	square inches square feet square yards square miles acres	AREA 6.5 0.09 0.8 2.6 0.4	square centimeters	cm <sup>2</sup>	square centimeters	0.16	square inches
			square meters	m <sup>2</sup>	square meters	1.2	square yards
			square kilometers	km <sup>2</sup>	square kilometers	0.4	square miles
			hectares	ha	hectares (10,000 m <sup>2</sup> )	2.5	acres
oz lb	ounces pounds short tons (2,000 lb)	MASS (weight) 28 0.45 0.9	grams	g	grams	0.035	ounces
			kilograms	kg	kilograms	2.2	pounds
			tonnes	t	tonnes (1,000 kg)	1.1	short tons
tsp Tbsp fl oz c pt qt gal ft <sup>3</sup> yd <sup>3</sup>	teaspoons tablespoons fluid ounces cups pints quarts gallons cubic feet cubic yards	VOLUME 5 15 30 0.24 0.47 0.95 3.8 0.03 0.76	milliliters	ml	milliliters	0.03	fluid ounces
			milliliters	ml	liters	2.1	pints
			milliliters	ml	liters	1.06	quarts
			liters	l	liters	0.26	gallons
			liters	l	cubic meters	35	cubic feet
			liters	l	cubic meters	1.3	cubic yards
			cubic meters	m <sup>3</sup>			
°F	Fahrenheit temperature	TEMPERATURE (exact) 5/9 (after subtracting 32)	Celsius temperature	°C	Celsius temperature	9/5 (then add 32)	Fahrenheit temperature

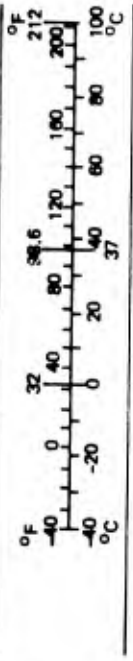
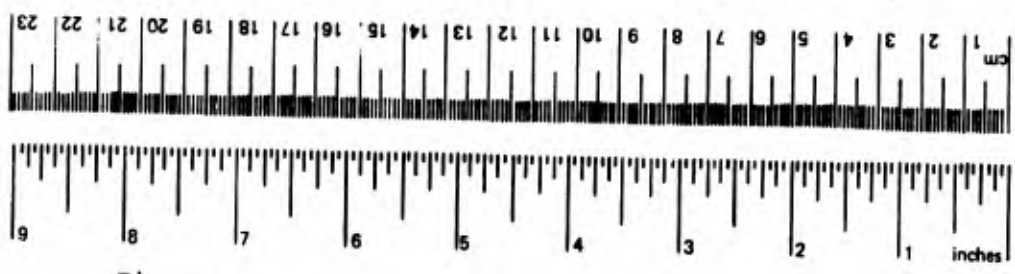

\*1 in = 2.54 (exactly). For other exact conversions and more detailed tables, see NBS Misc. Publ. 286, Units of Weights and Measures, Price \$2.25, SD Catalog No. C13.10-286.

Unclassified

SECURITY CLASSIFICATION OF THIS PAGE (When Data Entered)

REPORT DOCUMENTATION PAGE		READ INSTRUCTIONS BEFORE COMPLETING FORM
1 REPORT NUMBER CR 84.019	2 GOVT ACCESSION NO. AD-A140752	3 RECIPIENT'S CATALOG NUMBER
4 TITLE (and Subtitle) Navy Electroplating Pollution Control Technology Assessment Manual	5 TYPE OF REPORT & PERIOD COVERED Final Feb 1983 - Aug 1983	
	6 PERFORMING ORG REPORT NUMBER	
7 AUTHOR(s) George C. Cushnie, Jr.	8 CONTRACT OR GRANT NUMBER(s) F08635-81-C-0258	
9 PERFORMING ORGANIZATION NAME AND ADDRESS CENTEC Corporation 11260 Roger Bacon Drive Reston, VA 22090	10 PROGRAM ELEMENT PROJECT, TASK AREA & WORK UNIT NUMBERS PE63721N, Y0817 YF65.559.091.01.271	
11 CONTROLLING OFFICE NAME AND ADDRESS Naval Civil Engineering Laboratory Port Hueneme, CA 93043	12 REPORT DATE February 1984	
	13 NUMBER OF PAGES 239	
14 MONITORING AGENCY NAME & ADDRESS (if different from Controlling Office) Naval Facilities Engineering Command 200 Stovall Street Alexandria, VA 22332	15 SECURITY CLASS (of this report) Unclassified	
	15a DECLASSIFICATION DOWNGRADING SCHEDULE	
16 DISTRIBUTION STATEMENT (of this Report) Approved for public release; distribution is unlimited.		
17 DISTRIBUTION STATEMENT (of the abstract entered in Block 20, if different from Report)		
18 SUPPLEMENTARY NOTES		
19 KEY WORDS (Continue on reverse side if necessary and identify by block number) Pollution, electroplating wastewaters, conventional wastewater treatment, resource recovery, material recovery, plating bath technology		
20 ABSTRACT (Continue on reverse side if necessary and identify by block number) The report provides information on more than 27 separate technologies encompassing conventional treatment, alternate treatment, material recovery techniques and processes and new plating bath formulations. In addition, the incorporation of a section on in-plant process changes enhances the usefulness of the product in that it highlights noncapital-intensive		

DD FORM 1473 1 JAN 73 EDITION OF 1 NOV 65 IS OBSOLETE

Unclassified

SECURITY CLASSIFICATION OF THIS PAGE (When Data Entered)

Unclassified

SECURITY CLASSIFICATION OF THIS PAGE(When Data Entered)

changes to current practices and/or processes that may have significant bearing on reducing overall chemical and water usage costs as well as consequent wastewater treatment needs and disposal costs. This document was prepared as a joint Air Force-Navy effort. It is intended to serve as a guide for technical personnel making decisions on an appropriate means of meeting effluent limits. The selection of any of the described technologies should be done only after a rigorous identification of site requirements has been performed.

Unclassified

SECURITY CLASSIFICATION OF THIS PAGE(When Data Entered)

PREFACE

This document was prepared by CENTEC Corporation, Reston, Virginia, under Contract No. 086-35-81-C-0258 for the Air Force Engineering and Services Center Air Force Engineering and Services Laboratory (RDVA) and the Naval Civil Engineering Laboratory (NCEL).

This manual presents design and cost information for pollution control technologies that may have application to wastewaters generated by Naval and Air Force electroplating operations. It is intended to serve as a guide for technical personnel making decisions on the appropriate means of meeting effluent limits. Selection of any of the described technologies should be done only after a rigorous identification of the site requirements has been performed.

1st Lieutenant James Aldrich was the AFESC RDA Project Officer and Nicholas Olah was the NCEL Project Officer.

<b>Accession For</b>	
NTIS GRA&I	<input checked="" type="checkbox"/>
DTIC TAB	<input type="checkbox"/>
Unannounced	<input type="checkbox"/>
Justification	
By _____	
Distribution/	
Availability Codes	
Dist	Avail and/or Special
A-1	

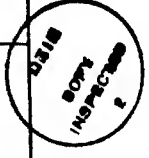

(The reverse of this page is blank.)

## TABLE OF CONTENTS

	<u>Page</u>
<b>SECTION I INTRODUCTION</b>	
A. Purpose of Manual . . . . .	1
B. Enabling Regulations . . . . .	1
C. Technology Overview . . . . .	6
D. Design Basis . . . . .	9
<b>SECTION II IN-PLANT PROCESS CHANGES</b>	
A. Overview . . . . .	10
B. Pollution Sources and Characteristics . . . . .	10
C. Minimizing Water Use . . . . .	12
D. Reducing Drag-Out Loss . . . . .	17
E. Plating Bath Purification . . . . .	27
F. Operation and Maintenance Demands and System Performance . . . . .	28
<b>SECTION III CONVENTIONAL TREATMENT TECHNOLOGIES</b>	
A. Overview . . . . .	30
B. Hexavalent Chromium Reduction--Sulfur Compound Reduction . . . . .	32
C. Cyanide Oxidation--Alkaline Chlorination . . . . .	40
D. Metal Hydroxide Precipitation . . . . .	48
E. Flocculation/Clarification . . . . .	55
F. Sludge Dewatering . . . . .	62
<b>SECTION IV SUBSTITUTE TREATMENT TECHNOLOGIES</b>	
A. Overview . . . . .	80
B. Sulfide Precipitation . . . . .	84
C. Ion Exchange . . . . .	96
D. Sodium Borohydride . . . . .	112
E. Ozone Oxidation . . . . .	116
F. Thermal Oxidation . . . . .	120
G. Freeze Crystallization . . . . .	124
H. Insoluble Starch Xanthate . . . . .	130
I. Sacrificial Iron Anodes . . . . .	136
J. Ultrafiltration and Microfiltration . . . . .	139
K. Ferrous Sulfate Reduction . . . . .	143
L. Integrated Treatment . . . . .	148
<b>SECTION V MATERIAL RECOVERY TECHNOLOGIES</b>	
A. Overview . . . . .	152
B. Evaporation . . . . .	157
C. Coupled Transport Membranes . . . . .	176
D. Electrodialysis . . . . .	181
E. Reverse Osmosis . . . . .	185
F. Electrolytic Cell Processes . . . . .	200
G. Donnan Dialysis . . . . .	210
H. Ion Transfer Membranes . . . . .	214

TABLE OF CONTENTS (Continued)

	<u>Page</u>
SECTION IV PLATING BATH SUBSTITUTION	
A. Overview . . . . .	220
B. Zinc Plating Baths . . . . .	220
C. Nickel Plating Baths . . . . .	227

## LIST OF FIGURES

	<u>Page</u>
1. Technology/Application Matrix . . . . .	7
2. Rinse Water Rates Required and Effluent Concentration for Counterflow Rinse Systems . . . . .	14
3. Estimating Rinse Ratios Based on Drag-out and Final Rinse Concentration for Multiple-Tank Rinse Systems . . . . .	15
4. Surface Evaporation Rate from Aerated Plating Baths . . . . .	20
5. Surface Evaporation Rate from Plating Baths with No Aeration . . . . .	21
6. Heat Load Resulting from Aeration of Plating Baths . . . . .	22
7. Rinse-and-Recycle Drag-Out Recovery . . . . .	24
8. Percent Drag-Out Recovery with Rinse-and-Recycle System . . . . .	25
9. Electroplating Industry Conventional Wastewater Treatment . . . . .	31
10. Effect of pH on Chromium Reduction Rate (From Patterson (Reference 7) . . . . .	34
11. Chromium Reduction Treatment Unit . . . . .	35
12. Effect of pH on ORP Control Set-Point for Chromate Reduction . . . . .	36
13. Two-Stage Cyanide Oxidation System . . . . .	41
14. Reaction Tower-Type Two-Stage Cyanide Oxidation System . . . . .	43
15. Response Curves of Available Electrodes for Cyanide to Cyanide Oxidation . . . . .	44
16. Installed Cost of Two-Stage Cyanide Oxidation Unit . . . . .	47
17. Single-Stage Neutralizer . . . . .	50
18. Cost of Neutralization/Hydroxide Precipitation Unit . . . . .	54
19. Rectangular Clarifier Basin . . . . .	57

LIST OF FIGURES  
(Continued)

	<u>Page</u>
20. Solids Contact Clarifier with Sludge Blanket Filtration . . . . .	59
21. Inclined Plate Settler . . . . .	60
22. Cross Section of Mixer/Clarifier . . . . .	61
23. Installed Cost of Clarifiers . . . . .	63
24. Plate-and-Frame Filter Press . . . . .	65
25. Rotary Vacuum Filter . . . . .	65
26. Basket Centrifuge . . . . .	69
27. Pressure Belt Filter . . . . .	70
28. Recessed Plate Filter Press Unit and Auxiliaries Needed for Sludge Dewatering . . . . .	75
29. Soluble Sulfide Treatment System . . . . .	86
30. Insoluble Sulfide Treatment Process Components . . . . .	88
31. Typical Ion Exchange Resin Column . . . . .	100
32. Ion Exchange Wastewater Purification and Recycle System . . . . .	102
33. Cost for Wastewater Deionization Units . . . . .	104
34. Ion Exchange Systems: (a) Polishing, (b) End-of Pipe Treatment . . . . .	106
35. Metals Removal Data: (a) Nickel and (b) Copper . . . . .	107
36. Unit Cost of Dual Column Resin Systems . . . . .	110
37. Chromic Acid Recovery RFIE Systems (a) Hardware Components, (b) Operating Cycle . . . . .	111
38. Diagram of Ozone Treatment System at San Diego Plating . . . . .	117
39. Process Flowsheet - Pressurized Thermal Destruction of Cyanides . . . . .	121

LIST OF FIGURES  
(Continued)

	<u>Page</u>
40. Process Flowsheet - Atmospheric Still for Thermal Decomposition of Cyanides . . . . .	123
41. Freeze Crystallization Process Flow Diagram . . . . .	126
42. Use of ISX as a Filter Precoat . . . . .	132
43. Sacrificial Iron Anode Process . . . . .	138
44. Installation Cost of an Electrochemical Chromium Reduction Unit . . . . .	140
45. Chromium Reduction Treatment Unit . . . . .	145
46. Redox Potential Control Set Point for $\text{FeSO}_4$ Chromium Reduction . . . . .	146
47. Integrated Treatment for Cyanide Plating Rinse Water . . . . .	149
48. Summary of Recovery Technology Applications . . . . .	153
49. Recovery Systems: (a) Closed Loop, (b) Open Loop . . . . .	155
50. Recovery Potential for a Two-Stage Counterflow Rinse . . . . .	156
51. Closed-Loop Evaporative Recovery of Plating Chemicals from Drag-Out . . . . .	158
52. Rising Film Evaporation for Chemical Recovery . . . . .	160
53. Flash Evaporation for Chemical Recovery . . . . .	161
54. Submerged Tube Evaporation for Chemical Recovery . . . . .	163
55. Atmospheric Evaporation for Chemical Recovery . . . . .	165
56. Utility Requirements for Single-Effect Evaporation . . . . .	167
57. Double-Effect Evaporation for Chemical Recovery . . . . .	168
58. Utility Requirements for Double-Effect Evaporation . . . . .	169
59. Mechanical Vapor Recompression Evaporation for Chemical Recovery . . . . .	171

LIST OF FIGURES  
(Continued)

	<u>Page</u>
60. Utility Requirements for Mechanical Vapor Recompression Units . . . . .	172
61. Open-Loop Evaporative Recovery of Plating Chemicals from Drag-Out . . . . .	174
62. Rinse Water Dilution vs. Rinse Ratio for Multitank Countercurrent Rinsing . . . . .	176
63. Capital Cost of Single-Effect Rising Film Evaporators . . . . .	177
64. Chromate Recovery, Co-Transport . . . . .	179
65. Metal Cation Recovery--Counter Transport . . . . .	180
66. Electrodialysis Unit Flow Schematic . . . . .	182
67. Electrodialysis Unit for Plating Drag-Out Recovery . . . . .	184
68. Plating Drag-Out Recovery Using Reverse Osmosis . . . . .	190
69. Mixed Wastewater Recycle via Reverse Osmosis . . . . .	196
70. Reverse Osmosis System Capital Cost vs. Membrane Surface Area . . . . .	198
71. Annual Savings from Nickel Plating Drag-Out Recovery . . . . .	199
72. Drag-Out Recovery from a Recirculated Rinse . . . . .	203
73. Cadmium and Cyanide Concentration (mg/l) in Recirculated Rinse vs. Time (min) . . . . .	206
74. Maximum Current Density for Copper Electrowinning . . . . .	208
75. Copper Deposition Rate as a Function of Current Density and Temperature . . . . .	209
76. Chromium Recovery by Ion Transfer Membrane Process . . . . .	216

LIST OF TABLES

	<u>Page</u>
1. Existing Pretreatment Standards for Job Shops and Printed Circuit Board Manufacturers . . . . .	3
2. Best Practical Technology and Best Available Technology for Integrated Facilities . . . . .	4
3. RCRA Hazardous Wastes Generated by Naval Electroplating Operations . . . . .	5
4. RCRA Hazardous Criteria for Evaluating Solid Wastes . . . . .	6
5. Waste Stream Design Characteristics . . . . .	9
6. Economic Penalty for Losses of Plating Chemicals . . . . .	18
7. Estimated Capital Costs for Purification Systems . . . . .	29
8. Summary of Treatment Levels Reported for Hexavalent Chromium Wastes . . . . .	37
9. Chromium Reduction Unit Cost . . . . .	38
10. Chemical Cost Factors for Chromium Reduction . . . . .	39
11. Treatment Levels for Cyanide Wastewaters . . . . .	45
12. Cyanide Oxidation Unit Cost . . . . .	46
13. Treatment Cost Factors . . . . .	48
14. Metal Solubility as a Function of pH . . . . .	52
15. Neutralization/Hydroxide Precipitation Unit Cost . . . . .	53
16. Dewatering Equipment for Electroplating Sludge: Typical Performance Characteristics . . . . .	72
17. Performance of Dewatering Equipment for Electroplating Sludge . . . . .	73
18. Comparative Total Investment and Annual Operating Costs for Sludge Dewatering . . . . .	78
19. Sludge Disposal Under Four Dewatering Alternatives: Analysis of Annual Costs . . . . .	79

LIST OF TABLES  
(Continued)

	<u>Page</u>
20. Pollutant Removal by Insoluble Sulfide Precipitation Treatment System . . . . .	91
21. Sulfide Precipitation of Cadmium, Zinc, and Mercury . . . . .	92
22. Removal of Complexed Copper and Other Metals from Electroplating Wastewater . . . . .	92
23. Installed Cost of Insoluble Sulfide Precipitation Treatment Systems . . . . .	93
24. Wastewater Characteristics and Treatment Process Parameters for Insoluble Sulfide Systems . . . . .	94
25. Removal of Zinc and Cadmium from Wastewater by Weak Acid Cation Resin . . . . .	108
26. Level of Sodium Borohydride Theoretically Required for Reduction of Various Metal Cations . . . . .	114
27. Estimated Installed Investment Costs for Sodium Borohydride Treatment System . . . . .	115
28. Estimated Variable Operating Costs for End-of-Pipe Treatment . . . . .	115
29. Performance of Ozone Treatment System at San Diego Plating . . . . .	118
30. Estimated Installed Investment Costs for Ozone Treatment System . . . . .	119
31. Estimated Variable Operating Costs . . . . .	119
32. Cyanide Removal from Alkaline Descaler at 477°F and 600 lb/in <sup>2</sup> Gauge . . . . .	122
33. Pilot Plant Results from Plating Rinsewater . . . . .	127
34. Estimated Installed Investment Costs for Two-Stage Freeze Crystallization Systems Designed for End-of-Pipe Treatment . . . . .	128
35. Estimated Variable Operating Costs for End-of-Pipe Treatment . . . . .	128

LIST OF TABLES  
(Continued)

	<u>Page</u>
36. Estimated Installed Investment Costs for Two-Stage Freeze Crystallization Systems for Chromium Recovery . . . . .	129
37. Estimated Variable Operating Costs for Two-Stage Cadmium Recovery System . . . . .	129
38. Removal of Heavy Metal Cations from Single Metal Solutions Using ISX . . . . .	134
39. Removal of Heavy Metal Cations from Mixed Metal Solutions Using ISX . . . . .	135
40. Metal Removal Results Using ISX as a Filter Precoat . . . . .	135
41. Evaluation of Electrodialysis Recovery for Cadmium Cyanide Plating . . . . .	186
42. Commercially Available Membrane Materials . . . . .	188
43. Evaluation of EPA-Supported and Private Reverse Osmosis Tests . . . . .	191
44. Existing Demonstrated Commercial Applications of Reverse Osmosis in the Metal Finishing Industry . . .	193
45. Economics of Reverse Osmosis System for Nickel Salt Recovery, Operating 4,000 h/yr . . . . .	201
46. Electrolytic Recovery Unit for Acid Copper Plating .	211
47. Evaluation of High-Surface-Area Electrolytic Recovery Unit for Cadmium Cyanide Plating . . . . .	212
48. Cost-Benefit Analysis of Ion Transfer Chromium Recovery Unit . . . . .	219
49. Characteristics of Conventional Zinc Cyanide Plating Baths . . . . .	223
50. Alkaline Zinc Baths: Typical Electroplating Solutions and Associated Operating Conditions . . . .	224
51. Neutral and Acid Zinc Baths: Typical Electroplating Solutions and Associated Operating Conditions . . . .	225
52. Typical Formation of Watts Nickel Bath . . . . .	229
53. Typical Formulations of Hypophosphite Type Electroless Nickel Plating Baths . . . . .	232

(The reverse of this page is blank.)

SECTION I  
INTRODUCTION

A. PURPOSE

This manual presents design and cost information for pollution control technologies that may have potential for adaptation in Naval or Air Force electroplating facilities. It is intended to serve as a guide for technical personnel who must choose appropriate means of meeting effluent limits. The manual presents information on conventional technologies for end-of-pipe treatment, as well as on substitute treatment technologies that may offer cost savings. Information is also presented on recovery technologies, water conservation techniques, and methods of reducing pollution by controlling or altering the electroplating operation.

B. ENABLING REGULATIONS

1. Wastewater

Wastewater discharges from electroplating/metal finishing operations are regulated under the Clean Water Act of 1977 (Public Law 95-217). The specific limits vary according to whether an industrial operation discharges directly to a waterway or indirectly through a sewage treatment facility. Wastewater treatment before indirect discharge is called pretreatment and the associated regulations are referred to as pretreatment standards.

The U.S. Environmental Protection Agency (EPA) published its proposed new regulations for wastewater discharge from electroplating/metal finishing industries on August 31, 1982 (Reference 1). These proposed regulations will be promulgated as final rules on June 30, 1983. They reflect some variations from the original regulations (Reference 2) and are the results of law suits and settlements reached with the industry groups. The salient features of the proposed regulations are:

- o A new category is created--Metal Finishing--and most large electroplaters are shifted to this new category.

- o The new category covers 45 unit operations, of which electroplating is one. These operations generate wastewater that falls into five waste groups: toxic metals, cyanide, toxic organics, oils, and conventional pollutants.
- o A new parameter, total toxic organics (TTO), is included for control, and it relates to 111 chemical compounds listed in the Federal Register.

EPA has divided the electroplating industry into two major sectors: job shops and captive facilities. The job shops are firms that finish metals as a service and do not own the materials they process. Captive facilities own the material they process. Captives are further divided by two definitions: (1) integrated plants are firms that, before discharge, combine electroplating waste streams with significant process waste streams from other operations; (2) nonintegrated facilities are those having significant wastewater discharges only from operations addressed by the electroplating category. Integrated facilities make up the new Metal Finishing category along with all direct dischargers.

By April 27, 1984, electroplating job shops are required to meet pretreatment standards given in Table 1. By June 30, 1984, integrated facilities (Metal Finishing category) are required to meet the same standards. By February 15, 1986, integrated facilities must meet the standards in Table 2.

The discharge of effluents to the navigable waters is regulated by NPDES permit issued to the industrial plant. NPDES permits are issued case-by-case by the authorized State agency or EPA, and the concentration limits specified in the permit are based on best practical technology (BPT) and best available technology (BAT) regulations, flow rate and quality of receiving waters, and pollutant concentration of industrial discharge.

Pretreatment standards are enforced on a local level. Municipalities must develop a pretreatment program that includes standards at least as stringent as the Federal standards. The programs are approved by the States, if the States have been authorized by EPA, otherwise they are approved by the EPA Regional Office.

Local authorities also can use removal credits established by EPA to allow higher pollutant concentrations than specified in pretreatment regulations if the publicly owned treatment works (POTWs) are configured to provide adequate treatment.

## 2. Hazardous Waste Regulations

Regulations governing hazardous wastes are a result of the Resource Conservation and Recovery Act (RCRA) of 1976

TABLE 1. EXISTING PRETREATMENT STANDARDS FOR JOB SHOPS AND PRINTED CIRCUIT BOARD MANUFACTURERS

Pollutants	Plants Discharging >10,000 gal/d		Plants Discharging <10,000 gal/d	
	Daily Maximum (mg/l)	4-Day Average (mg/l)	Daily Maximum (mg/l)	4-Day Average (mg/l)
Cadmium	1.2	0.7	1.2	0.7
Chromium, total	7.0	4.0	NR	NR
Copper	4.5	2.7	NR	NR
Nickel	4.1	2.6	NR	NR
Lead	0.6	0.4	0.6	0.4
Silver	1.2	0.7	NR	NR
Zinc	4.2	2.6	NR	NR
Total regulated metals (Cr, Cu, Ni, Zn)	10.5	6.8	NR	NR
Cyanide	1.9 <sup>a</sup>	1.0 <sup>a</sup>	5.0 <sup>b</sup>	2.7 <sup>b</sup>

<sup>a</sup>Total cyanide.

<sup>b</sup>Cyanide amenable to chlorination.

NOTE: NR = not regulated.

TABLE 2. BEST PRACTICAL TECHNOLOGY AND BEST AVAILABLE TECHNOLOGY FOR INTEGRATED FACILITIES

Pollutants	Pretreatment and Effluent Guidelines (mg/l)	
	Daily Maximum	30-Day Average
Cadmium	1.29 (0.064) <sup>a</sup>	0.27 (0.018) <sup>a</sup>
Chromium, total	2.87	0.80
Copper	3.72	1.09
Nickel	3.51	1.26
Lead	0.67	0.23
Silver	0.44	0.13
Zinc	2.64	0.80
Cyanide, total	1.30	0.28
Total toxic organics	0.58	0.58
Oil and grease <sup>b</sup>	42.0	17.0
Total suspended solids <sup>b</sup>	61.0	22.9

<sup>a</sup>Cadmium limit for new sources.

<sup>b</sup>Applies only to effluent guidelines for direct dischargers. pH limit for direct dischargers is 6.0-9.0.

NOTE: The compliance date for indirect dischargers (to POTW) is February 15, 1986; for direct dischargers the date is July 1, 1984.

(Public Law 94-580). RCRA hazardous waste regulations are designed to manage and control the country's hazardous wastes from generation to final disposal.

The RCRA regulations differ from those concerned with water pollution in that water regulations vary according to the specific industry (for example, metal finishing) to which they are directed, whereas all industries that generate, store, haul, or dispose of hazardous waste must comply with the same set of rules.

Under RCRA, the EPA has set strict definitions for hazardous waste (Reference 3). Some wastes, such as electroplating wastewater treatment sludge, are specifically listed as hazardous wastes (Table 3). For wastes not specifically listed, EPA has established a set of criteria that the waste generator must apply to determine if the waste is hazardous (Table 4). If a waste is listed as hazardous or is judged hazardous using the criteria in Table 4, it must be stored, transported, and disposed of in accordance with RCRA hazardous waste regulations.

---

TABLE 3. RCRA HAZARDOUS WASTES GENERATED BY NAVAL  
ELECTROPLATING OPERATIONS

---

EPA Hazardous Waste Number	Hazardous Waste
F006	Wastewater treatment sludges from electroplating operations
F007	Spent plating bath solutions from electroplating operations
F008	Plating bath sludges from the bottom of plating baths from electroplating operations
F009	Spent stripping and cleaning bath solutions from electroplating operations

---

If wastes listed by EPA as hazardous do not possess hazardous characteristics the generator can petition EPA (or an authorized state) to delist the waste. If successful in the delisting process the generator can dispose of the waste in a less costly manner. Some electroplating operations have been successful in delisting their wastewater treatment sludges (Reference 4).

TABLE 4. RCRA HAZARDOUS CRITERIA FOR EVALUATING SOLID WASTES

Criterion	Characteristics <sup>a</sup>
Ignitability	Waste is liquid with a flash point less than 140°F. Waste is solid that burns vigorously and persistently when ignited. Waste is ignitable compressed gas.
Corrosivity	pH is less than or equal to 2. pH is greater than or equal to 12.5. Waste is highly corrosive to steel.
Reactivity	Substance is unstable and readily undergoes violent changes without detonating. Substance reacts violently in water. Waste forms potentially explosive mixtures with water. Material generates toxic gases when mixed with water. Waste contains cyanide or sulfide.
Toxicity	Waste fails the Extraction Procedure (EP) test for toxicity.

<sup>a</sup>A detailed set of characteristics is contained in 40 CFR 261.

### C. TECHNOLOGY OVERVIEW

The wastewater treatment technologies presented in this manual have been categorized as follows:

- Pollution/Water Reduction
- Conventional Treatment
- Substitute Treatment
- Material Recovery
- Plating Bath Substitution

Each category of technologies is discussed in a separate section of the manual. In some cases a technology falls in two categories, such as substitute treatment and metal recovery; however, in the manual, such a technology appears only in one section, under the category of its primary application, where the secondary application is also discussed. Figure 1 summarizes the scheme by which the technologies are categorized.

TECHNOLOGY CATEGORIES

TECHNOLOGIES	POLLUTION/WATER REDUCTION	CONVENTIONAL TREATMENT	SUBSTITUTE TREATMENT	MATERIAL RECOVERY
CHROMIUM REDUCTION (sulfur dioxide reduction)		●		
COUPLED TREATMENT MEMBRANES	○			●
CYANIDE OXIDATION (alkali chlorination)		●		
DONNAN DIALYSIS	○			●
ELECTRODIALYSIS	○			●
ELECTROLYTIC	○			●
EVAPORATIVE RECOVERY	○			●
FERROUS SULFATE			●	
FLOCCULATION/CLARIFICATION		●		
FREEZING			●	
HYDROXIDE PRECIPITATION		●		
INSOLUBLE STARCH XANTHATE			●	
INTEGRATED WASTEWATER TREATMENT			●	
ION EXCHANGE	○		●	○
ION TRANSFER MEMBRANES				●
KASTONE			●	
MINIMIZING WATER USE	●			
OZONE			●	
PLATING BATH PURIFICATION	●			
PLATING BATH SUBSTITUTION	●			●
REDUCING DRAG-OUT LOSS	●			
REVERSE OSMOSIS	○			●
SACRIFICIAL Fe ANODES			●	
SLUDGE DEWATERING		●		
SODIUM BOROHYDRIDE			●	
SULFIDE PRECIPITATION			●	
THERMAL OXIDATION			●	
ULTRAFILTRATION	○		●	

LEGEND:

- PRIMARY APPLICATION
- SECONDARY APPLICATION

Figure 1. Technology/Application Matrix

The methods discussed in the section on Pollution/Water Reduction are control techniques that involve changes to current methods of rinsing and related plating processes. These techniques, which are generally non-capital-intensive, can have the overall effect of reducing:

- Chemical purchases
- Water use (resulting in lower water and sewer costs)
- Wastewater treatment needs and disposal costs

Often termed in-plant changes, these methods are the first step an electroplating facility should take to comply with either wastewater or RCRA regulations. In addition to providing chemical savings and reducing water use costs, in-plant changes provide a basis for a pollution control system design. Waste treatment equipment needs--whether wastewater concentrating techniques, such as ion exchange, or conventional end-of-pipe treatment systems--often will be reduced significantly by in-plant changes.

Conventional treatment technologies are those pollution control processes that are widely used and have become the standard to which other technologies are compared. Conventional treatment was used by EPA as a basis for developing the Federal effluent regulations (Reference 1). The conventional treatment processes consist of (1) hexavalent chromium reduction using sulfur dioxide, (2) cyanide oxidation by alkali chlorination, (3) hydroxide precipitation, (4) flocculation/clarification, and (5) solids separation.

Substitute treatment technologies are processes that can be used in place of one or more of the conventional technologies. Although less widely used, most of these processes offer some advantages over conventional treatment, for example, lower capital or operating costs or reduced sludge generation. As a rule, these advantages are gained at the expense of other benefits. Such trade-offs are often site-specific and must be evaluated case by case.

Material recovery technologies include processes that reclaim plating chemicals for reuse. Their development and application derives from the rising costs of replacing and treating plating chemicals. These processes operate mostly on the same basic principle; they concentrate the drag-out plating solution contained in the rinse water to the degree that the solution can be returned to the plating bath.

Plating bath substitution can have a significant effect on the pollutant loading of a treatment system. The use of new solutions, such as noncyanide zinc and low-concentration nickel baths, reduces the need for treatment chemicals and results in

less sludge generated. Several of the new processes have limited application, however, or they can reduce the quality of the deposit. The trade-offs must be carefully analyzed when such processes are considered for use.

#### D. DESIGN BASIS

One purpose of this manual is to provide sufficient information for comparison of the various technologies. To meet this objective, a standard has been defined for design flow rate and waste composition. For each technology, a process design has been prepared and capital and operating costs have been estimated, based on the design waste flows and characteristics.

Because the size of Navy and Air Force electroplating operations varies widely, two design flow rates have been selected--30 gal/min and 100 gal/min. It has been assumed that these flows are composed of three segregated waste streams, chromium, cyanide, and acid alkali, of equal flow with characteristics shown in Table 5:

TABLE 5. WASTE STREAM DESIGN CHARACTERISTICS

Pollutant	Waste Stream		
	Chromium (mg/l)	Cyanide (mg/l)	Acid/Alkali (mg/l)
Chromium (+6)	12	0	0
Chromium (total)	18	0	0
Cadmium	0	12	0
Copper	3	6	3
Nickel	3	0	3
Zinc	0	0	3
Lead	0	0	3
Iron	36	0	36
Cyanide	0	15	0

Such segregation is typical of plating waste streams, because preliminary treatment of chromium- and cyanide-bearing wastes is performed during conventional treatment before these wastes are combined with the remaining acid/alkali waste stream.

Also, waste stream characteristics vary widely among electroplating operations. Some facilities use innovative rinsing that concentrates the pollutants. Other facilities are less prudent with water use and, as a result, have very dilute wastes. The concentration of pollutants has a significant effect on the operating costs of treatment (e.g., treatment chemical costs and sludge disposal costs) and also affects the process design for certain metal recovery technologies.

## SECTION II

### IN-PLANT PROCESS CHANGES

#### A. OVERVIEW

Metal finishing operations in the United States are subject to a variety of changing conditions. Two of the most significant factors are (1) the increasing costs of materials, such as plating chemicals and process water and (2) environmental considerations, which include the need to control the discharge of effluent waste streams and the disposal of hazardous wastes. The future effectiveness of many metal finishing operations will depend on how well they deal with the impact of these changes and requirements.

The basic plating operation involves immersing parts in a process solution, then rinsing off the clinging film of plating chemicals known as drag-out. If performed inefficiently, this operation wastes several pounds per day of expensive plating chemicals and creates thousands of gallons per day of contaminated rinse water. Inefficient operation, therefore, significantly affects the interrelated factors of material costs and pollution control.

Because of rising prices, it is necessary to reevaluate water pollution control techniques and costs and to examine methods for improving raw material yields. In many cases, changing the manufacturing process can significantly alter chemical losses and water flow rates. These in-plant changes usually involve techniques for reducing both the drag-out from process solutions and the amount of water used in the rinsing process.

In-plant changes should be the first step in developing a pollution control system. In addition to saving chemicals and reducing water use costs, in-plant changes can significantly reduce end-of-pipe treatment requirements and provide a savings in process equipment.

#### B. POLLUTION SOURCES AND CHARACTERISTICS

Contaminants in the effluent from electroplating shops originate in several ways. The most obvious source of pollution is the drag-out of various processing baths into subsequent rinses. The amount of pollutants contributed by drag-out is a function of such factors as the design of the racks or barrels carrying the parts to be plated, the shape of the parts, plating procedures, and several interrelated parameters of the process solution, including concentration of toxic chemicals, temperature, viscosity, and surface tension.

With conventional rinsing techniques, drag-out losses from process solutions result in large volumes of rinse water contaminated with relatively dilute concentrations of cyanide and metals. Rinse waters that follow plating solutions typically contain 15 mg/l to 100 mg/l of the metal being plated.

Most military plating shops operate several plating lines containing different types of cleaning and electroplating baths, such as zinc, copper, nickel, cadmium, and chromium. The combined rinse waters dilute the concentrations of individual metals, usually to less than 25 mg/l.

Discarded process solutions are another source of effluent contamination. These solutions are primarily spent alkaline and acid cleaners used for surface preparation of parts before electroplating. The solutions are not usually made up of metals; however, a few cleaners contain cyanide. Plating baths and other process solutions containing high metal concentrations, such as chromate solutions, are rarely discarded. However, some shops do discard such solutions on a regular basis.

The amount of pollutants contributed to the total pollution load by discarded cleaning solutions varies considerably among plating shops. It is not uncommon for these solutions to be contaminated by cyanide and heavy metals in concentrations of several thousand milligrams per liter. This contamination is caused by drag-in from previous process cycles and attack of the base metals by the chemicals in the cleaning solutions.

Accidental spills, leaks, and drips of process solutions also can contribute significantly to effluent contamination. The plating room usually is laid out so that the entire area drains from the floor, which is only an extension of the sewer system leaving the facility. Although it is unusual for a tank to spring a leak that would allow the entire solution to leak away undetected, a slow leak losing from 10 to 20 gal/d could go undetected for months in many shops. Also, it is not unusual to compensate for evaporation losses in a process tank by adding water to a process solution with an unattended hose that causes overflow of the solution to the floor drains (Reference 5).

In some shops, the dripping of plated parts is a significant source of pollution. Process solution tanks and rinse tanks are often separated by several feet. Carrying the racks of parts between tanks will cause plating solution or drag-out to drip on the floor and enter the drain system.

Other sources of contaminants from electroplating shops include sludges from the bottoms of plating baths generated during chemical purification, backwash from plating tank filter systems, and stripping solutions. These sources, however, are not as common as those described in the preceding paragraphs.

The percentage that each pollution source contributes to the pollutant concentration of the final effluent can vary substantially among electroplating shops. For shops whose primary process is the decorative chrome plate, drag-out will usually be the major cause of metal loss. For shops that perform mostly hard chromium plating, the ventilation system exhaust will usually exceed losses due to drag-out. Similarly, at facilities that engage in large nickel plating operations, more nickel is lost from the operation of chemical purification filters and through sludge bottom dumps after purification than through drag-out. The main contribution to effluent metal concentration in zinc or cadmium plating is often the zinc or cadmium that is either stripped off the danglers or rack tips in the acid dip step of the cleaning cycle or removed from the work in dichromating.

Although some shops may have a higher contribution of pollutants from other sources, in almost every case, the most significant pollution problem is drag-out and the resultant contaminated rinse water. The size and cost of pollution control equipment depend primarily on wastewater volumetric flow rate. Because the volumes of rinse water are overwhelmingly larger than the volumes of all other waste sources, it follows that contaminated rinse water is the major source of pollution.

Electroplating shops should concentrate on drag-out and rinse waters during the planning stages of pollution control. Therefore, this section emphasizes the reduction of drag-out and rinse water use. To provide a comprehensive approach to in-plant control, however, other sources of contamination, such as discarded process solutions, will be addressed.

### C. MINIMIZING WATER USE

The major demand for water (as much as 90 percent) is in the rinse tanks that follow the different plating process steps. Consequently, the greatest potential for reducing wastewater flow rates is in these tanks. Rinsing is used to dilute the concentration of contaminants adhering to the surface of a workpiece to an acceptable level before the workpiece passes on to the next step in the plating operation. The amount of water needed to dilute the rinse solution depends on the quantity of chemical drag-in from the upstream rinse or plating tank, the allowable concentration of chemicals in the rinse water, and the efficiency of contact between the workpiece and the water.

Various techniques are used in the electroplating industry to reduce the volume of water needed to achieve the required dilution, including:

- Installing multiple rinse tanks after a processing bath to reduce the required rinse rate radically

- Using conductivity cells to control water addition to rinse tanks and avoid excessive dilution of the rinse water
- Installing flow regulators on rinse water feed lines to control the addition rate at the minimum amount required
- Reusing contaminated rinse water where feasible

#### 1. Multiple-Rinse Tanks

If multiple-rinse tanks are installed after the process bath, with the rinse flowing in a direction counter to that in which the parts move (Figure 2), the quantity of chemicals entering the final rinse will be significantly reduced compared with that entering a single-tank rinse system. The amount of rinse water required for dilution will be reduced by the same degree; the volume can be predicted for each rinse step by the use of a model that assumes complete rinsing of the workpiece. The ratio,  $r$ , of rinse water volume to drag-out volume is approximated by:

$$r = (C_p/C_n)^{1/n}$$

where

$C_p$  = concentration in process solution

$C_n$  = required concentration in last rinse tank

$n$  = number of rinse tanks

This model does not predict required rinse rates accurately when the value of  $r$  falls below 10. Also, complete rinsing will not be achieved unless there is sufficient residence time and agitation in the rinse tank.

Figure 3 shows the volume of rinse water required as a function of initial concentration in the plating bath, required concentration in the final rinse tank, and number of rinse tanks. For example, a typical Watts-type nickel plating solution contains 270,000 mg/l of total dissolved solids. Assuming the final rinse must contain no more than 37 mg/l of dissolved solids, the ratio of  $C_p$  to  $C_n$  is 7,300, and approximately 7,300 gallons of rinse water are required for each gallon of process solution drag-in with a single-tank rinse system. Installing a two-stage rinse system reduces water requirements to 86 gallons of water per gallon of process solution drag-in. The same degree of dilution is obtained in the final rinse, and the rinse water consumption is reduced by 99 percent. The mass flow of pollutants from the rinse system remains constant.

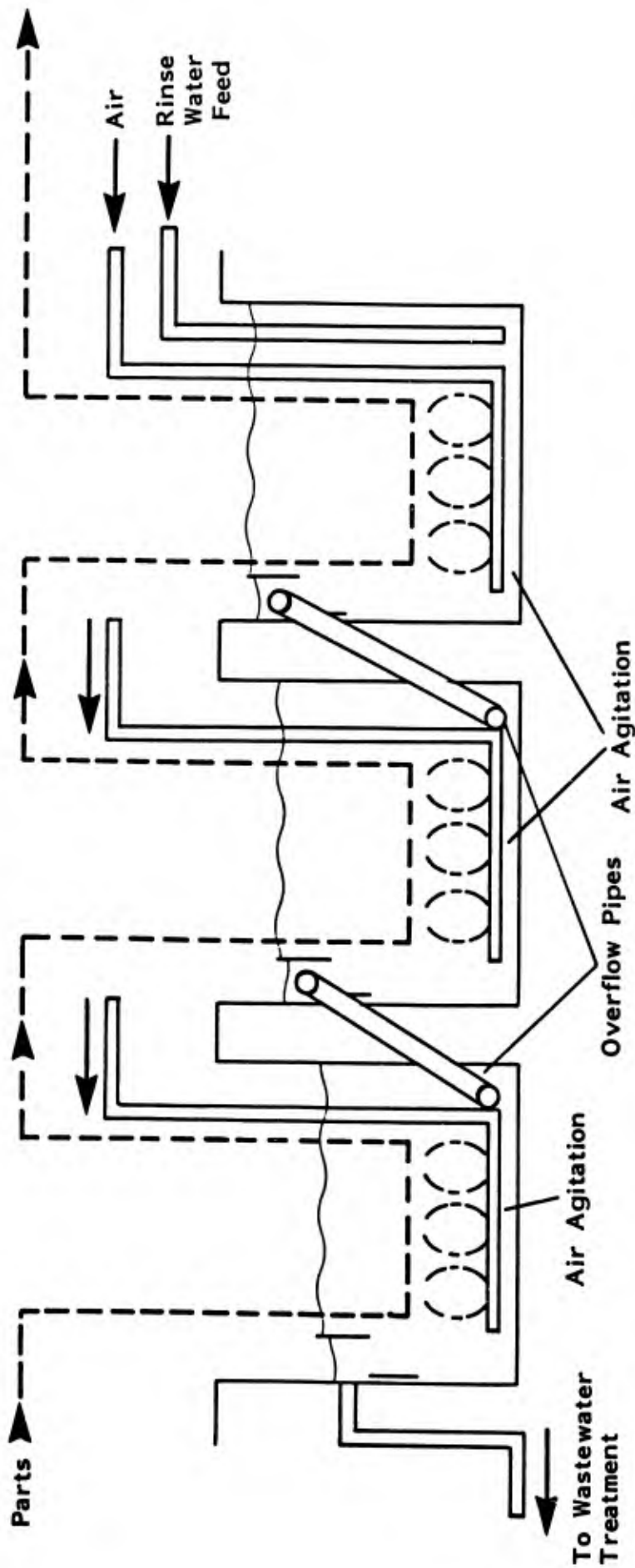

No. of Rinse Stages	Rinse Ratio <sup>a</sup>	Spent Rinse Water Concentration (mg/l)
1	1,000	37
2	100	370
3	10	3,700
4	6	6,170

NOTE: Three-stage counter-current rinse with onboard arrangement.

<sup>a</sup> Required to Maintain Concentration in Final Rinse at 37 mg/l in the Drag-Out Concentration Equals 37,000 mg/l.

Figure 2 . Rinse Water Rates Required and Effluent Concentration for Counterflow Rinse Systems

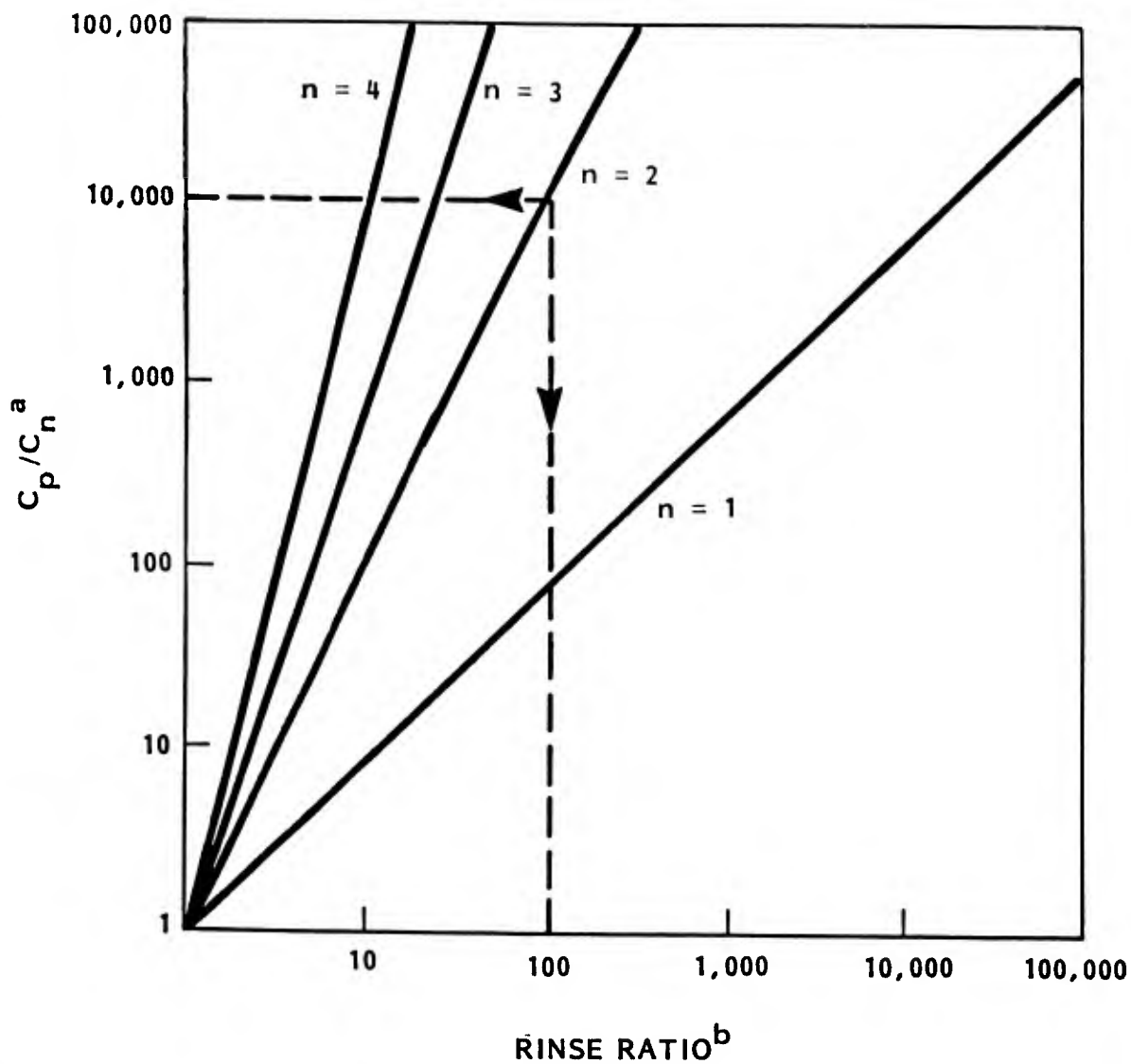

<sup>a</sup> $C_n$  = concentration in final rinse:  $C_p$  = concentration in process bath;  
 $n$  = number of rinse tanks.

<sup>b</sup>Rinse ratio = gal rinse water/gal drag-out.

NOTE: The graph shows rinse ratios for countercurrent rinse systems. For parallel rinse systems, multiply the rinse ratio for a countercurrent arrangement with the same number of tanks by the number of tanks, e.g., two-stage countercurrent rinse with  $C_p/C_n = 10^4$  has a rinse ratio of 100 gal/gal, but with the two-stage series the required rinse is  $100 \times 2 = 200$  (gal rinse water/gal drag-out).

Figure 3. Estimating Rinse Ratios Based on Drag-Out and Final Rinse Concentration for Multiple-Tank Rinse Systems

If this bath had a drag-out rate of 0.5 gal/h, the single rinse tank would require 3,650 gal/h of rinse water (0.5 x 7,300). A three-stage countercurrent rinse arrangement would reduce water consumption from 3,650 gal/h to 10 gal/h (0.5 x 20). The resulting cost benefits would include reducing water use and sewer fees by \$7.20/h (based on \$2/1,000 gallons combined water use and sewer fees) and reducing the size of the required waste treatment systems, which are designed on the basis of volumetric flow rate (Reference 5).

The investment cost to add two additional rinse tanks is highly site-specific; for manual plating operations, the major factor affecting cost would be the availability of space in the process area. For automatic plating machines, the cost of modifying the unit to add additional stations may be as high as \$20,000 per station. The cost, excluding installation, is in the range of \$1,000 to \$1,500, depending on surface area required for the workpiece (Reference 5).

A parallel rinse arrangement also can be used with multiple-rinse tanks. In this case, each rinse tank receives a fresh water feed and discharges the overflow to waste treatment. The rinse ratio required for a series rinse arrangement is defined by

$$r = n(C_p/C_n)^{1/n}$$

If the rate given in Figure 2 for a countercurrent rinse system with the same number of rinse tanks is multiplied by the number of rinse tanks, the series rinse water rate can be estimated. Rinse water rates are significantly higher for series rinsing.

## 2. Conductivity Cells

A conductivity cell or probe is another water-saving device widely used in rinsing systems. Except on highly automated plating machines, the frequency of rinse dips generally varies considerably. Because the fresh rinse water is usually fed continuously, there are periods of excess dilution and, consequently, of excess water use. A conductivity cell measures the level of dissolved solids in the rinse water. When the level reaches a preset minimum, it shuts a valve, interrupting the fresh water feed. When the concentration of dissolved solids reaches the maximum allowable level, the cell opens the valve. Thousands of these units are used throughout industry and in military operations because of their reasonable cost. A complete unit, including a probe, controller, and automatic 1-inch valve can be purchased and installed for \$200 to \$1,000 (Reference 5).

However, reliability problems have been observed at most installations using conductivity probes. Often the controller is packaged in a metal box which is subject to corrosion. The probes have also presented maintenance problems. When these systems do not function properly, platers may override the system and water use rates are no longer reduced.

### 3. Flow Regulators

Flow regulators can be used as a water conservation step to control the fresh water feed within a narrow range despite variations in line pressure. These devices eliminate the need to reset the flow each time the valve is closed. They have also been designed to act as syphon breakers and aerators (by the venturi effect), and are provided in a wide range of flow settings. The units cost approximately \$10 to \$30.

### 4. Water Reuse

Reusing rinse water will reduce water use. In critical or final rinsing operations, the level of contaminants remaining on the workpiece must be extremely low; however, for some intermediate rinse steps the level of contaminants can be higher. Water consumption can be reduced by reuse of the contaminated overflow from the critical rinse in a rinse for which water specifications are less critical. Water also can be reused if the contaminants left in rinse water after a processing step do not detract from the rinse water quality at another rinsing station. For example, the overflow from the rinse that follows an acid dip can be reused as the feed to rinse that follows an alkaline dip. Choosing the optimum configuration requires analyzing the particular rinse water needs. Interconnections between rinsing systems might make operations more complicated, but the cost advantage they represent justifies the extra attention they require.

#### D. REDUCING DRAG-OUT LOSS

As a workpiece emerges from a plating bath, it carries over a volume of plating solution into the rinse system. This carry-over, known as drag-out, is usually the major source of pollutants in an electroplater's waste stream. Table 6 shows the economic penalty suffered for each pound of assorted plating chemicals lost to the waste stream. The cost of replacing the raw materials and treating and disposing of the waste is high; consequently, the cost effectiveness of modifications to minimize drag-out is very attractive.

Generally, one of two approaches can be used:

- Drag-out can be reduced before rinsing
- Rinse water can be recycled to the plating bath

TABLE 6. ECONOMIC PENALTY FOR LOSSES OF PLATING CHEMICALS

Chemical	Cost (\$/lb)			Total
	Replacement	Treatment <sup>a</sup>	Disposal <sup>b</sup>	
Nickel:				
As NiSO <sub>4</sub>	0.76	0.28	0.17	1.21
As NiCl <sub>2</sub>	1.04	0.29	0.24	1.57
Zinc cyanide as Zn(CN) <sub>2</sub> :				
Using Cl <sub>2</sub> for cyanide oxidation	1.41	0.72	0.25	2.38
Using NaOCl for cyanide oxidation	1.41	1.53	0.25	3.19
Chromic acid as H <sub>2</sub> CrO <sub>4</sub> :				
Using SO <sub>2</sub> for chromium reduction	0.78	0.48	0.32	1.58
Using NaHSO <sub>3</sub> for chromium reduction	0.78	0.69	0.32	1.79
Copper cyanide as Cu(CN) <sub>2</sub> :				
Using Cl <sub>2</sub> for cyanide oxidation	1.95	0.72	0.25	2.92
Using NaOCl for cyanide oxidation	1.95	1.53	0.25	3.73
Copper sulfate as CuSO <sub>4</sub>	0.56	0.28	0.17	1.01

<sup>a</sup>Based on treatment at a concentration of 100 mg/L in wastewater.

<sup>b</sup>Based on disposal at 4% solids and \$0.10/gal.

Various recovery percentages are achievable depending on the number of rinse tanks in the rinsing system, the concentration of pollutants permissible in the final rinse tank, and the volume of rinse water that can be recycled to the plating tanks. To assess the potential economy of drag-out recovery, the quantity of plating solution lost to the rinse system must be determined. A first approximation of this quantity can be derived by multiplying the quantity of plating chemicals added to the bath by an assumed loss factor. The loss factors for plating baths are typically between 50 and 90 percent.

#### 1. Drag-Out Recovery from Rinse Tanks

The drag-out loss from the plating bath can be reduced significantly by recycling modifications, which are usually low cost, after rinsing modifications are completed. As a rule, these modifications are applicable to baths that have a considerable amount of surface evaporation. The rinse water containing dragged-out plating chemicals can be returned to the plating bath from the rinse tanks to make up for water lost by surface evaporation.

Low temperature baths have minimum surface evaporation and their temperature cannot be increased without degrading heat-sensitive additives. Recently, new additives, which are not as readily heat degraded, have been developed for many of these plating baths. These additives might make it possible to operate the plating bath at higher temperatures, facilitating recycle techniques for drag-out recovery. Usually, the value of the recovered chemicals is much greater than the increased energy cost associated with operating the bath at a higher temperature.

The evaporation rate determines the total volume of rinse water that can be recycled to the plating tanks. The quantity of the plating chemicals in the recycled rinse water represents the savings of plating chemicals previously lost to the pollution control system. If the required rinse water rate can be matched to the evaporation rate, no rinse water is discharged to waste treatment and the plating bath is operated as a closed-loop system.

The rate of surface evaporation for plating tanks with air agitation is shown in Figure 4; the rate for those without air agitation (surface evaporation only) is shown in Figure 5. If air agitation significantly increases the evaporation rate, it also will significantly increase the heat loss from a plating tank and the energy cost to keep the bath at its operating temperature. Figure 6 shows the heat needed to compensate for heat loss resulting from the use of air agitation. The heat loss caused by surface evaporation in a plating bath without air agitation can be calculated from: Heat load (Btu/h) = surface evaporation (gal/h) x 8,300 (Btu/gal).

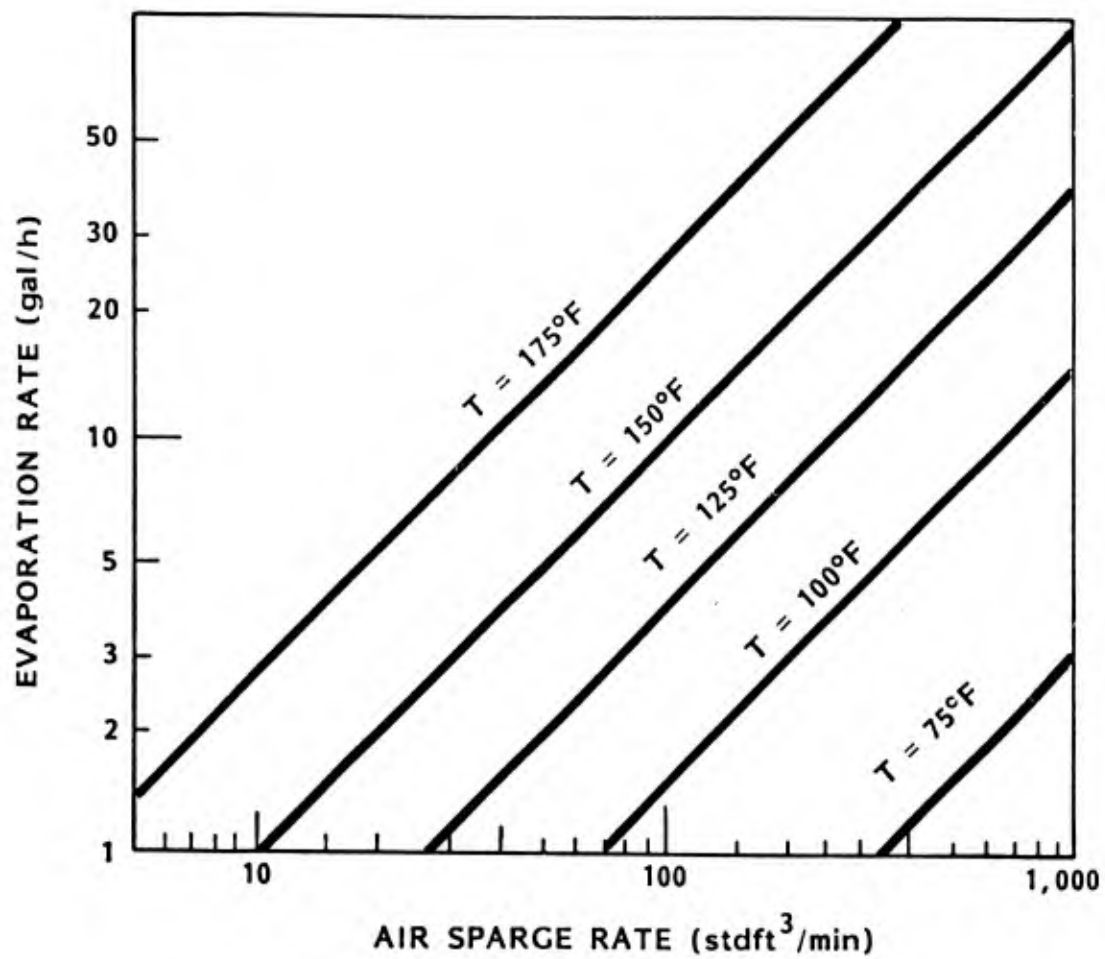

NOTES: Supply air at 75°F, 75% relative humidity. Plating solution is 95% mole fraction H<sub>2</sub>O. T = plating bath temperature.

Figure 4. Surface Evaporation Rate from Aerated Plating Baths

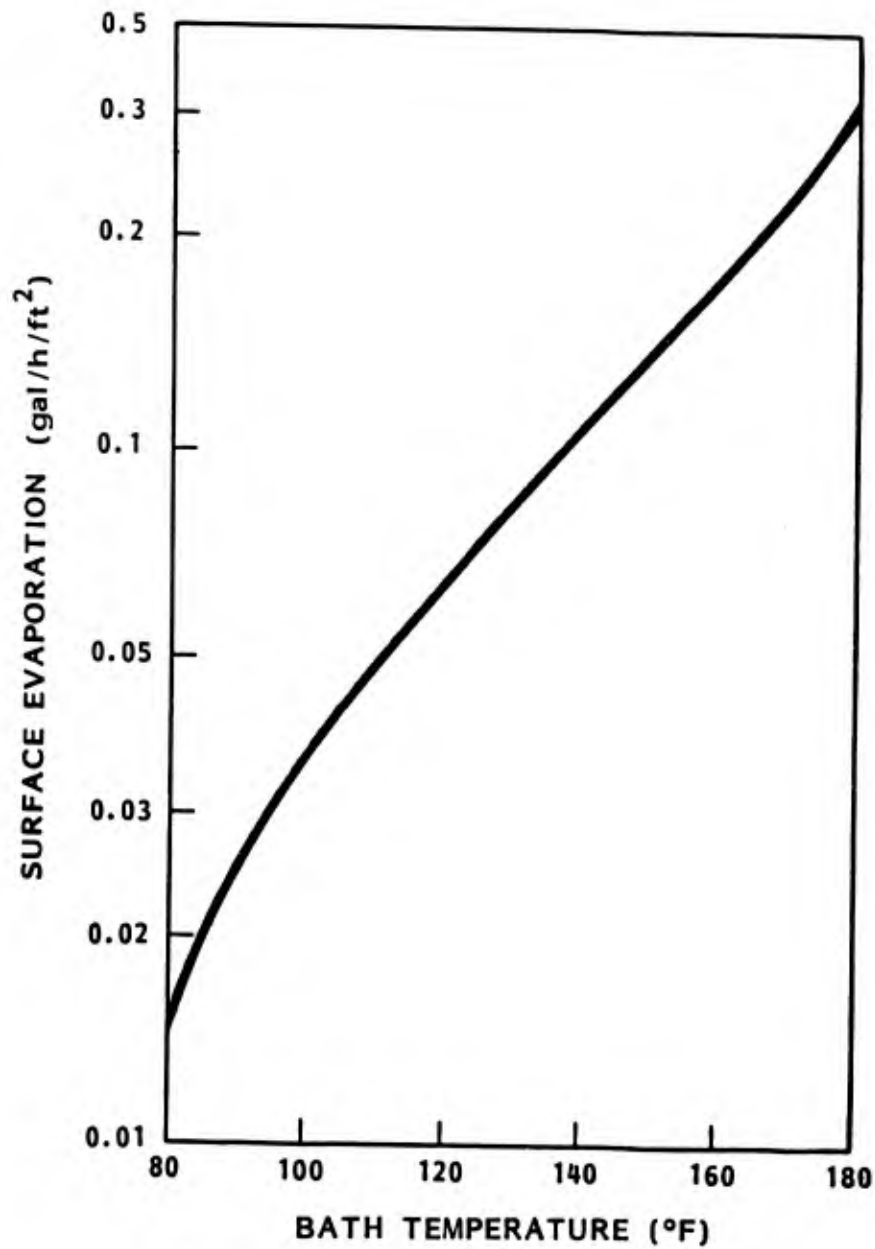

NOTES: Ambient conditions are 75°F, 75% relative humidity.  
Plating solution is 95% mole fraction H<sub>2</sub>O.

Figure 5. Surface Evaporation Rate from Plating Baths with No Aeration

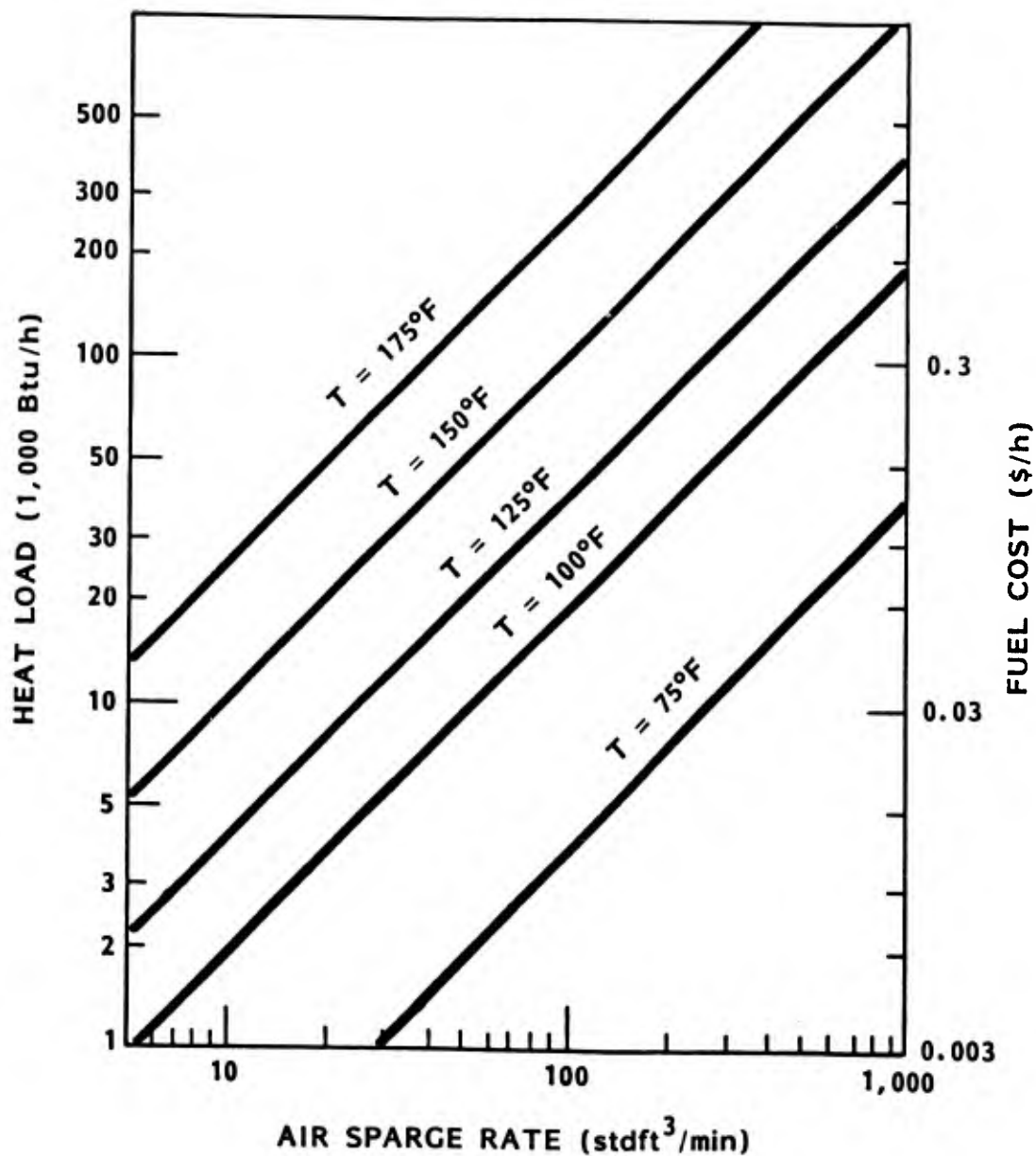

NOTE: Supply air at 75°F, 75% relative humidity. Plating solution is 95% mole fraction H<sub>2</sub>O. Fuel cost to supply heat load based on energy supply at \$3/10<sup>6</sup> Btu. T = Plating bath temperature.

Figure 6. Heat Load Resulting from Aeration of Plating Baths

For example, two plating tanks, each with a 30 ft<sup>2</sup> surface area, are operated at 150°F. One uses 100 stdft<sup>3</sup>/min air agitation, and the second operates without air agitation. The surface evaporation rates would be 9.8 gal/h and 4.2 gal/h, respectively. The heat inputs required would be 107,500 and 34,860 Btu/h, respectively. Using indirect steam heating to compensate for the heat loss would cost \$0.32/h for the air-agitated bath compared to \$0.10/h for the bath without air agitation, based on an energy cost of \$3/10<sup>6</sup> Btu.

Significant drag-out recovery can be achieved for each plating tank by use of a multistage rinse system and return of the concentrated rinse water to the bath to compensate for the evaporation losses. If the required rinse water rate were equal to the evaporation rate, the entire volume of rinse water could be returned to the plating bath. For this case, the following formula compares the recovery of drag-out with an operation with no recycle:

$$\text{Percent recovery of drag-out} = [1 - (C_n/C_p)] \times 100\%$$

where:

$C_p$  = concentrations in plating bath

$C_n$  = concentrations in final rinse tank

The only loss is drag-out from the last rinse tank, which has a dilute concentration of plating chemicals (References 5 and 6).

When a low final-rinse concentration is required, excessive drag-out occurs, or surface evaporation is minimal, a closed-loop, countercurrent rinse-and-recycle system will probably be impractical because of the large number of rinse stages required.

When the final rinse in a multiple-tank system is operated as a free rinse and the upstream tanks are used as a countercurrent rinse-and-recycle system, significant drag-out recovery can still be realized while rinsing quality is maintained. Figure 7 shows such a system, and Figure 8 shows the percent recovery of drag-out as a function of recycle ratio, which is the volume of recycled rinse divided by the volume of drag-out. The recycle rinse rate in the recovery rinse tanks is equal to the evaporation rate. The data in Figure 3 can be used to determine the required water rates for the final rinse once the concentration in the recovery rinse is known.

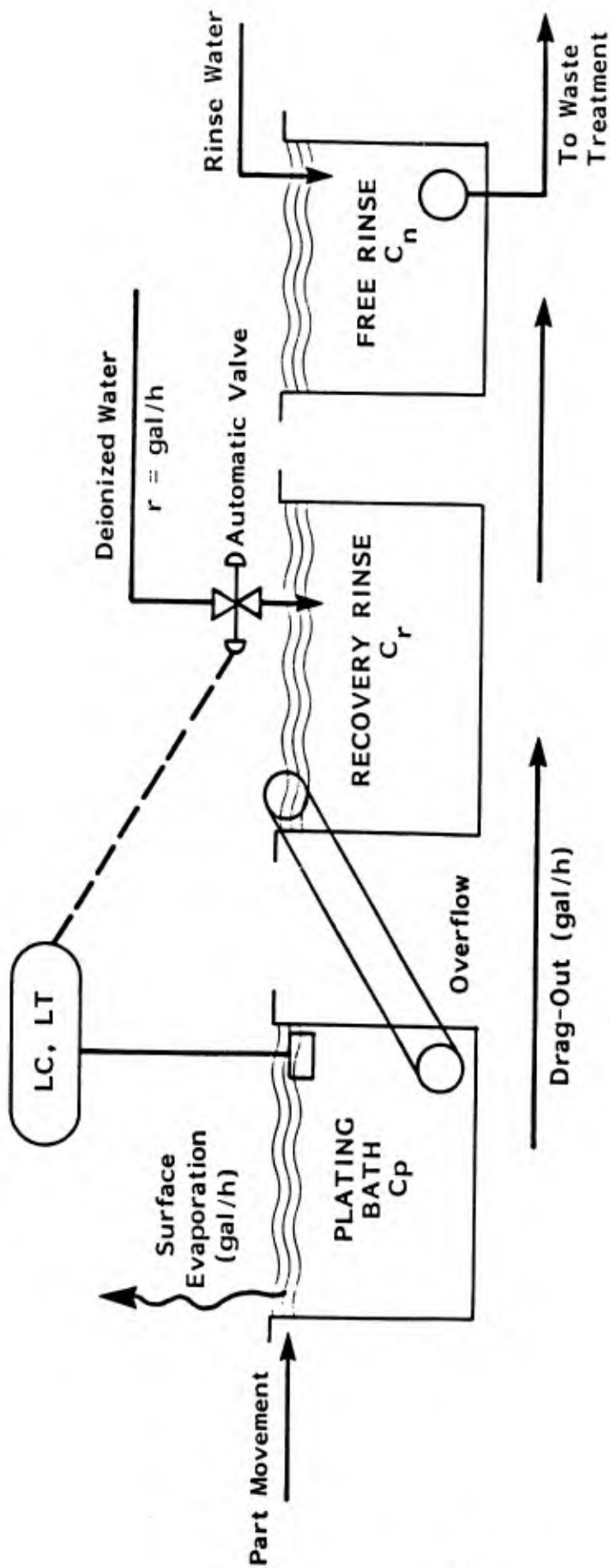

NOTE:  $C_p$  = Concentration in plating bath.  $C_r$  = concentration in final stage recovery.  
 $C_n$  = Concentration in final rinse. LC, LT = level controller and transmitter.

Figure 7. Rinse-and-Recycle Drag-Out Recovery

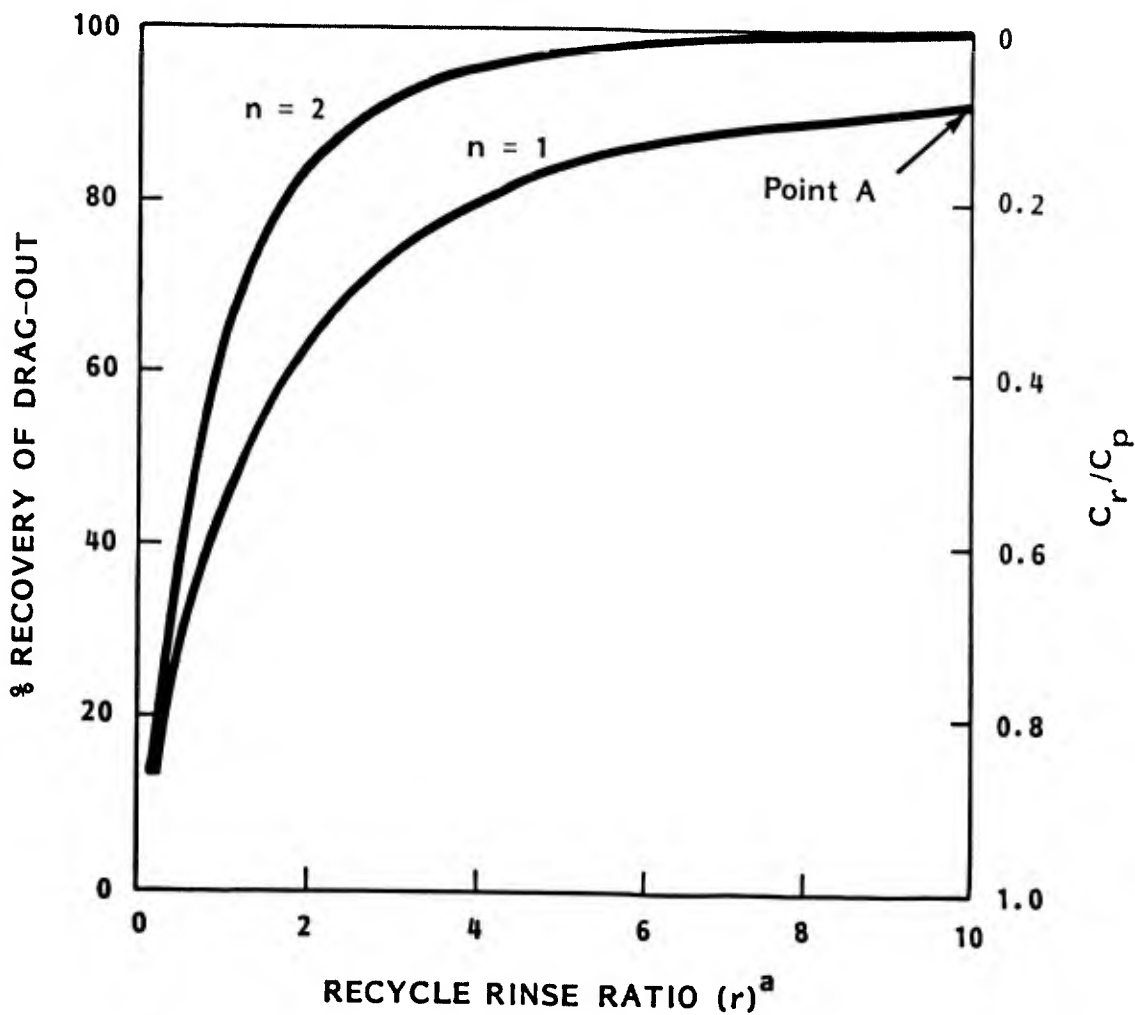

$a_r$  = Recycle rinse (gal/h)/drag-out (gal/h).

NOTE:  $r$  (recycle rinse flow) = surface evaporation from bath.  
 $n$  = number of counterflow rinse tanks in recovery use.

Figure 8. Percent Drag-Out Recovery with Rinse-and-Recycle System

As an example, a nickel plating operation has these operating characteristics: a drag-out rate of 0.5 gal/h, a surface evaporation rate of 5 gal/h, and a final rinse concentration of 40 mg/l. Therefore, the recycle ratio could be set at 10. From Figure 5, a one-stage recovery rinse and recycle system would reclaim 90 percent of the drag-out (point A). At this recovery rate, the concentration ratio is 0.10. Assuming an initial plating tank concentration of 270,000 mg/l, the concentration entering the final rinse is  $0.10 \times 270,000$ , or 27,000 mg/l. The water requirements in the final rinse would be reduced by the same level as drag-out losses, when compared with the required rinse rates for a single-tank rinse system. Calculated using Figure 3, 337 gal/h is the rinse water requirement in the final rinse tank.

## 2. Reducing Drag-Out from Plating Tanks

Spray rinses and air knives are two effective methods of reducing the concentration or volume of plating solution lost from the plating tanks.

Spray rinses are ideal for reducing drag-out from the plating tank on automated lines. As the workpiece is withdrawn mechanically from the plating solution, a spray of water automatically washes the part, draining as much as 75 percent of the chemicals back into the plate tank. Again, the volume of spray rinse cannot exceed the volume of surface evaporation from the plate tank. Spray rinsing is best suited for flat parts, but will reduce drag-out effectively on any part plated.

The savings are calculated in terms of the concentration change in the drag-out. For example, if the concentration of the drag-out were 100,000 mg/l and a spray rinse reduced the concentration to 50,000 mg/l, the chemical losses would be reduced by 50 percent.

Hard chromium plating, a major process at most military shops, is unique in that the parts are plated for hours or days rather than minutes like most plating processes. The hard chromium baths provide an excellent opportunity for spray rinsing since the evaporation rates usually far exceed drag-out rates. Many platers simply hose down parts after removal from the process while the parts are suspended over the bath and recover nearly all of the drag-out. After spray rinsing the parts can be dipped into a still rinse for final rinsing; however, many private industry platers skip the final rinse and have zero-discharge from hard chromium plating.

An air knife can be used to reduce drag-out in much the same way as can a spray rinse, particularly when the surface evaporation rate in the plating bath is low. The savings in operating costs are equal to the percent reduction in volume of drag-out adhering to the workpiece. The concentration of the dragged-out solution remains the same.

## E. PLATING BATH PURIFICATION

Batch dumps of spent electroplating solutions are a major source of pollution from some military plating shops. Although the volumes of spent solutions are small compared with rinse water flows, the concentration of metals in the baths is extremely high. Typically, the spent solutions are placed in drums and are contractor-hauled to treatment/disposal areas. A few military facilities bleed the concentrated wastes into their treatment systems. In either case, the cost of disposal is high. The solutions present a high demand for treatment reagents and generate large volumes of sludge. Combined with the replacement costs for the plating solution, the disposal of spent solutions ranges from \$4 to \$12 per gallon. Therefore, there is a substantial incentive to purify solutions and avoid disposal.

The methods of conventional bath purification can be divided into preventive and curative (or restorative) categories. Some methods fall into both categories. The technologies have been in use for several decades, but applications have been extended to more types of baths in recent years. Because any plating bath may be unique in its application and composition, consultation with the technical service department of chemical and equipment suppliers is the first step in deciding the most effective way of maintaining a bath or of restoring it to operating condition.

To aid in determining what purification method to use and to prevent bath misuse a log of bath use is important. Horror stories exist about baths that had to be dumped repeatedly until some unsuspected use factor was finally identified. Today, baths can be sent to a reclaimer instead of being dumped. For example, chromium plating baths can be sent to a facility where the chromic acid is recovered for resale. Approved shipping containers or tank trucks must be used to conform to State and Federal regulations for transportation of hazardous materials.

The five basic purification techniques are filtration, chemical treatment, carbon treatment, physical/chemical treatment, and electrolytic treatment ("dummying"). Continuous filtration is recommended for most plating baths to remove solid particles that can cause roughness or other plating defects. This applies to chromium, nickel, copper (acid and cyanide), cadmium, zinc, and electroless nickel baths. Filtration is also used as a routine batch treatment, together with chemical or carbon treatment. Carbon treatment is used to remove organic compounds. Frequently, brighteners in plating baths break down with continued operation and, before replacement brighteners are added, the bath is treated with activated carbon in bulk or is pumped through a carbon chamber.

Chemical treatments include peroxide or permanganate oxidation of organics in a bath. An example is the "stripping"

of brighteners from a bath so that correct concentrations can be established by addition of a new complement of brighteners. Calcium or barium hydroxide, barium cyanide, or calcium sulfate can be added to a cyanide bath to precipitate potassium carbonate. Sodium carbonate can be precipitated by freezing, then removed by filtration. Carbonates reduce the efficiency of cyanide plating baths and may affect deposit quality.

Dummying is used on nickel, copper, and chromium plating baths. For nickel and copper baths, the objective of this electrolytic purification is removal of trace metals that affect plate quality. Dummying of chromium baths is used in the special case where high cathode-to-anode area ratio has resulted in build up of trivalent chromium ( $\text{Cr}^{+3}$ ). Dummying with a high anode-to-cathode area ratio can be used to reoxidize the trivalent to hexavalent chromium ( $\text{Cr}^{+6}$ ). Proper scheduling of work can avoid the problem in many instances.

Replacement of older types of electroless nickel baths with newer, maintainable baths avoids batch dumps of depleted baths. Also, provision of an auxiliary tank and pumps will allow these baths to be saved when autocatalytic deposition on the working tank occurs.

The specific combination of treatment sequences and temperatures should be worked out with materials and equipment suppliers for each type of bath and use. In most instances, a Hull cell test will be invaluable as a control or troubleshooting tool. Results from Hull cell tests can inform a bath operator of incipient trouble before there is significant work loss.

#### F. OPERATION AND MAINTENANCE DEMANDS AND SYSTEM PERFORMANCE

Bath purification at the preventive level may appear to represent a significant commitment of time and resources. The objective, however, is the ability to operate a plating shop without unscheduled interruptions. As an example, with filtration, some hard chromium baths have been operating for 15 years; formerly the baths were cleaned out and dumped about twice a year.

##### 1. Residuals Generated

Residuals generated from bath purification methods include: solids composed primarily of filter aid, but containing metallic compounds that may require handling as hazardous waste; from activated carbon treatment, spent carbon that will have mostly organic contaminants; sodium, calcium, or barium carbonate containing cyanide; chlorine gas generated by dummying a bath to remove excess chloride; metal cathodes used for dummying baths.

## 2. Cost Factors

The Capital costs for bath purification will be for pumps and filters. Operating costs will be for electricity, activated carbon, filter aid, replacement filters, and chemicals (hydrogen peroxide, potassium permanganate). Table 7 gives estimated capital costs for bright nickel, electroless nickel, and hard chromium purification systems.

TABLE 7. ESTIMATED CAPITAL COSTS<sup>a</sup> FOR PURIFICATION SYSTEMS

System	Amount (\$)
Bright nickel or cadmium bath (2 turnovers/h): In-tank filter with pump and 1/3-horsepower Motor for continuous filtration	640 <sup>b</sup>
Periodic carbon treatment using suspended carbon, pump with 1/3-horsepower motor, and 35 pound granulated carbon	1,520
Total	2,160 <sup>b,c</sup>
Electroless nickel (5 turnovers/h): Vertical, in-tank, bearing-free pump with 1-horsepower motor and bag filter at \$60-\$70 per tube	1,155
Hard chromium (2 turnovers/h): In-tank filter with pump and 1/3-horsepower motor for continuous filtration	640 <sup>c</sup>

<sup>a</sup>Based on a 250-gallon bath.

<sup>b</sup>For high-chloride bath at elevated temperatures, out-of-tank unit with magnetic drive would be used. Unit cost would be \$895 and total would be \$2,415.

<sup>c</sup>Does not include filter tubes at \$2.50-\$3.50 each.

## SECTION III

### CONVENTIONAL TREATMENT TECHNOLOGIES

#### A. OVERVIEW

The pollutant discharge levels called for in the pretreatment regulations are based on the performance of numerous electroplating treatment systems employing conventional treatment. Conventional treatment is a series of unit processes used extensively by industry that have provided reliable treatment for many electroplating operations. Figure 9 is a schematic of a conventional treatment facility for electroplating wastes containing chromium and cyanides in addition to other heavy metals, acids, and alkalis.

The configuration of conventional treatment is relatively standard. It consists generally of the following unit processes:

- Chromium reduction (if needed) of segregated chromium waste streams to reduce the chromium from its hexavalent form to the trivalent state, which then can be precipitated as chromium hydroxide by alkali neutralization
- Cyanide oxidation (if needed) of segregated cyanide-bearing waste streams to oxidize the toxic cyanides to harmless carbon and nitrogen compounds
- pH adjustment of the combined metal-bearing wastewaters, strong chemical dumps, and the effluent from the cyanide and chromium treatment systems to precipitate the dissolved heavy metals as metal hydroxides
- Clarification with flocculation/coagulation to promote the initial settling of the precipitated metal hydroxides
- Gravity thickening over extended time to increase solids content of sludge before disposal
- Sludge dewatering using a mechanical device to further increase the solids content of the sludge

These unit processes provide effective, reliable treatment for most electroplating waste streams. That is not to say, however, that such treatment is suitable for all applications

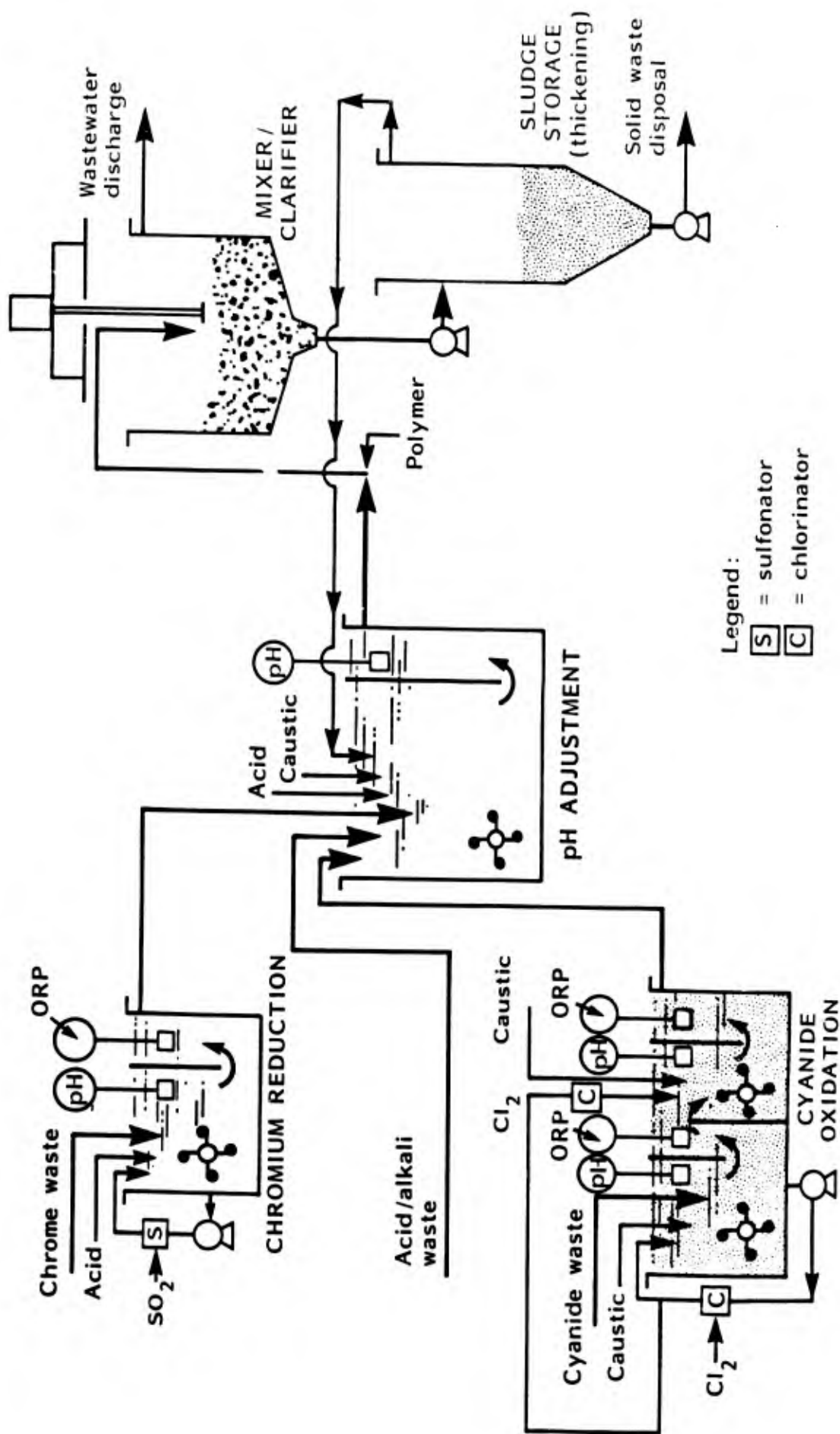

Figure 9. Electroplating Industry Conventional Wastewater Treatment

or that the "normal" design parameters (retention time, reagent dosage, and so forth) will provide effective pollutant removal for the wastewater of every individual plating operation. Treatability studies are needed to assess the applicability of a treatment process to a specific wastewater.

The costs presented in this section assume all components of the individual systems must be purchased. Costs can be reduced by use of existing pumps, tanks, and instrumentation. Higher installation costs, however, can result from site-specific costs for wastewater collection systems, new building space, structural modifications, or relocation of existing equipment.

Flow rate is a major factor in determining equipment cost, and pollutant loading and flow rate are both significant in determining the operating cost of the system. Estimates for both equipment and operating cost are provided for each unit process, based on the assumptions presented in Section I.

## B. HEXAVALENT CHROMIUM REDUCTION--SULFUR COMPOUND REDUCTION

### 1. Summary and State of Technology Development

Use of chemical reducing agents--such as sulfur dioxide ( $\text{SO}_2$ ), sodium bisulfite ( $\text{NaHSO}_3$ ), or sodium metabisulfite ( $\text{Na}_2\text{S}_2\text{O}_5$ )--is the most widely practiced treatment method for reducing hexavalent chromium ( $\text{Cr}^{6+}$ ) to the trivalent form ( $\text{Cr}^{3+}$ ). After reduction, the chromium can be removed from the wastewater as chromium hydroxide ( $\text{Cr}(\text{OH})_3$ ) by an increase in the wastewater pH to above 8.0. Normally, segregated chromium wastes are treated to reduce the hexavalent chromium, then mixed with the rest of the plating wastewater in the pH adjustment/precipitation step to separate the chromium hydroxide.

Performance of chemical reducing systems has proven reliable in countless operations; it is common to reduce the level of hexavalent chromium to below the detection limit (0.05 ppm) of atomic adsorption analyzers.

The main disadvantage of the system is the need to reduce the wastewater pH to approximately 2.5 to realize a rapid reduction reaction rate. The wastewater must then be neutralized before discharge. These steps not only consume considerable amounts of acid and base but--with the conventional practice of using sulfuric acid ( $\text{H}_2\text{SO}_4$ ) and lime ( $\text{Ca}(\text{OH})_2$ )--calcium sulfate, unreacted lime, and other precipitants add significantly to the volume of sludge generated. Also the process has a tendency to release gases having a noxious odor, which can be an annoyance in indoor treatment systems.

### 2. Process Description

Wastewater from chromium plating, chromating, and chromic acid anodizing contains chromium in both the hexavalent

and trivalent form. Although most heavy metals are precipitated readily as insoluble hydroxides by pH adjustment in the neutralizer, hexavalent chromium first must be reduced to trivalent chromium. Reduction usually is done by reaction with gaseous sulfur dioxide or a solution of sodium bisulfite. The net reaction using sulfur dioxide is:

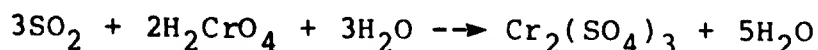

Because the reaction proceeds rapidly at low pH (Figure 10), acid is added to control the wastewater pH between 2.0 and 3.0. Figure 11 diagrams a conventional stirred-tank reactor chromium reduction system. Sulfuric acid is added to maintain the pH at the desired level and sodium bisulfite is added based on the oxidation reduction potential (ORP) control set point.

The ORP control set point is strongly influenced by the pH maintained in the reaction vessel. The control set point varies by approximately 150 millivolts (mV) per change in pH unit (Figure 12); pH control is significant in minimizing variation.

Also, the reaction end point is more distinct at lower pH. Consumption of reducing chemicals will normally average 50 to 100 percent of stoichiometric requirements. Atmospheric oxygen will consume a significant part of the reducing agent, particularly if the reaction vessel is open to the air.

### 3. Operation and Maintenance Demands and System Performance

Operation and maintenance of sulfur dioxide (or metabisulfite) reduction systems require no skills beyond those normally associated with wastewater treatment operator training. Routine activities include:

- Maintaining reagent supply
- Performing scheduled cleaning and calibration of pH and ORP probes
- Regular collecting and analysis of treated samples to verify system performance
- Regularly scheduled maintenance on pumps and mixers

The systems have generally proven reliable if well maintained. Again, the interrelationship between solution pH and ORP set point warrants calibration checks at least once per shift.

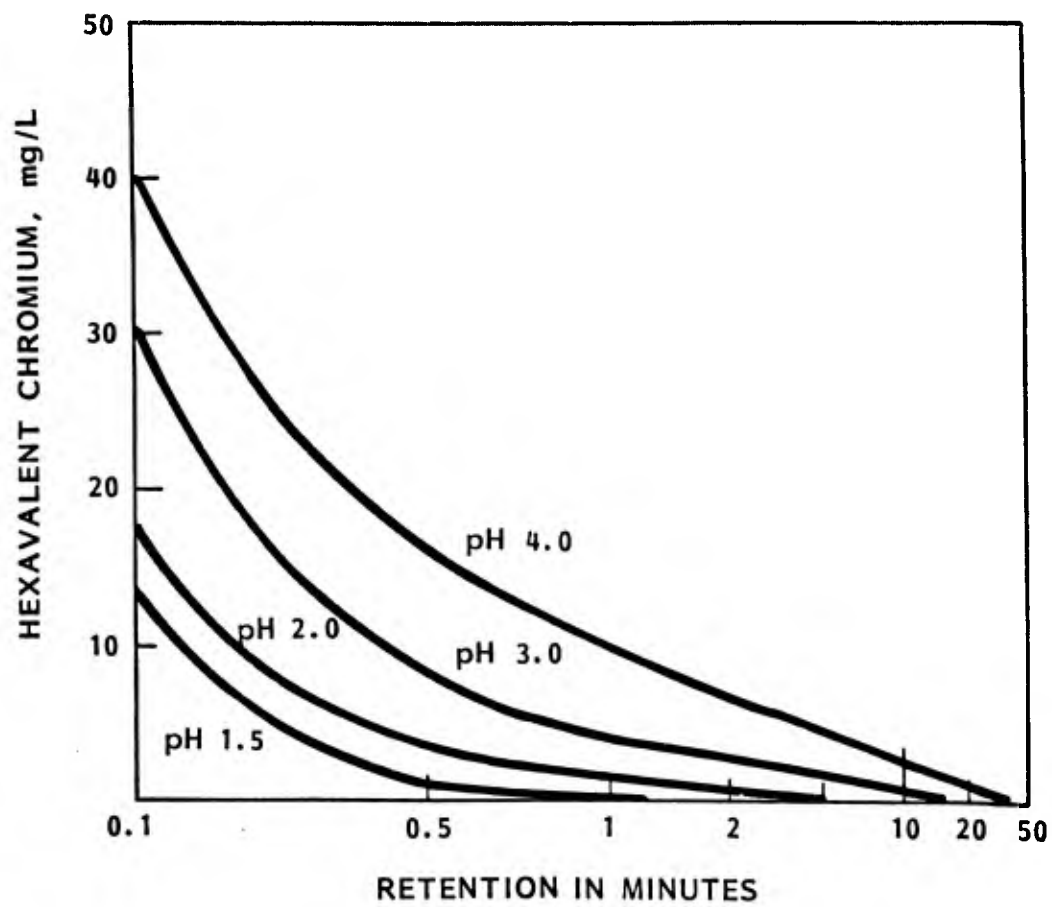

Figure 10. Effect of pH on Chromium Reduction Rate (From Patterson, Reference 7)

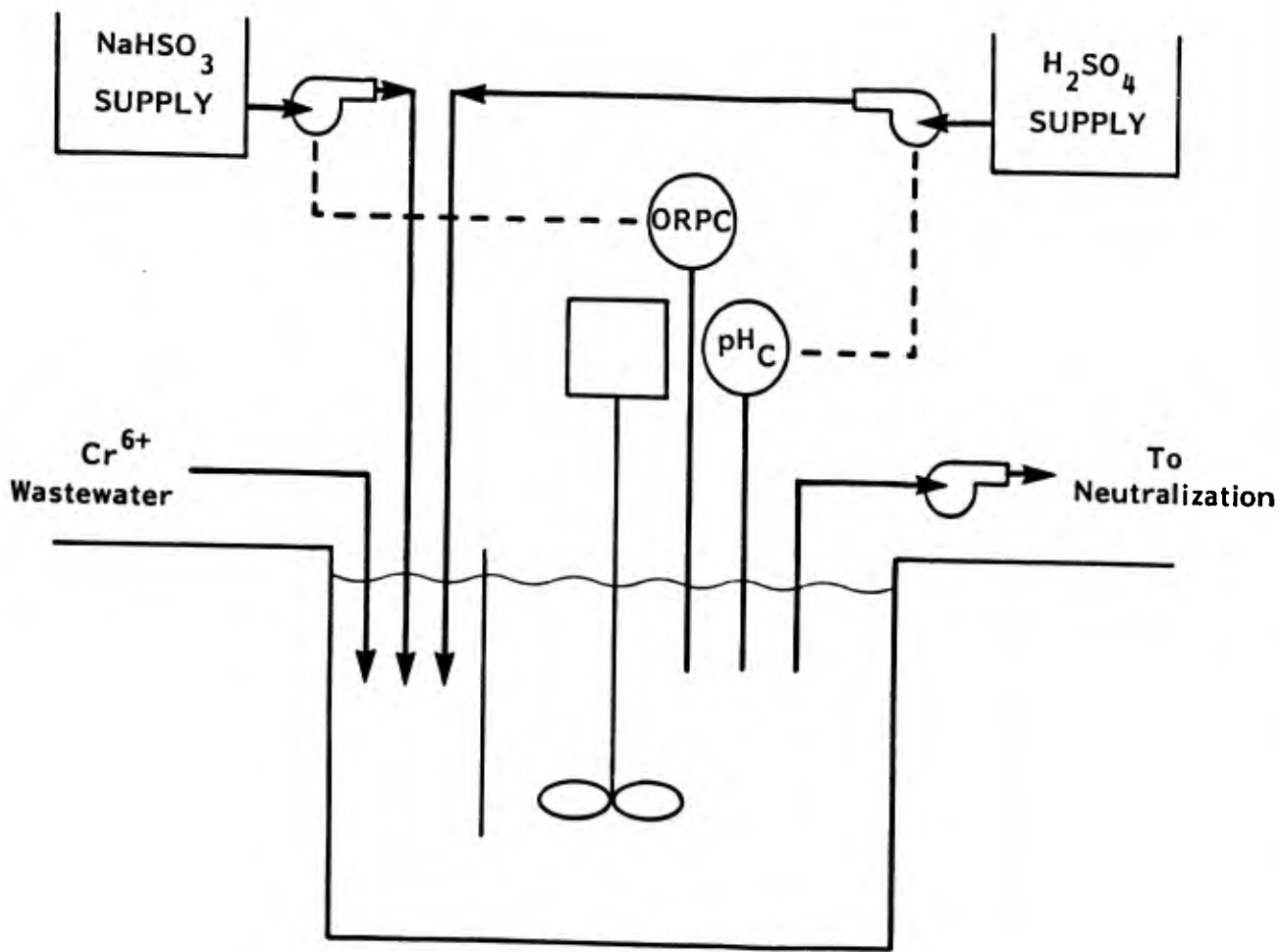

Figure 11. Chromium Reducation Treatment Unit

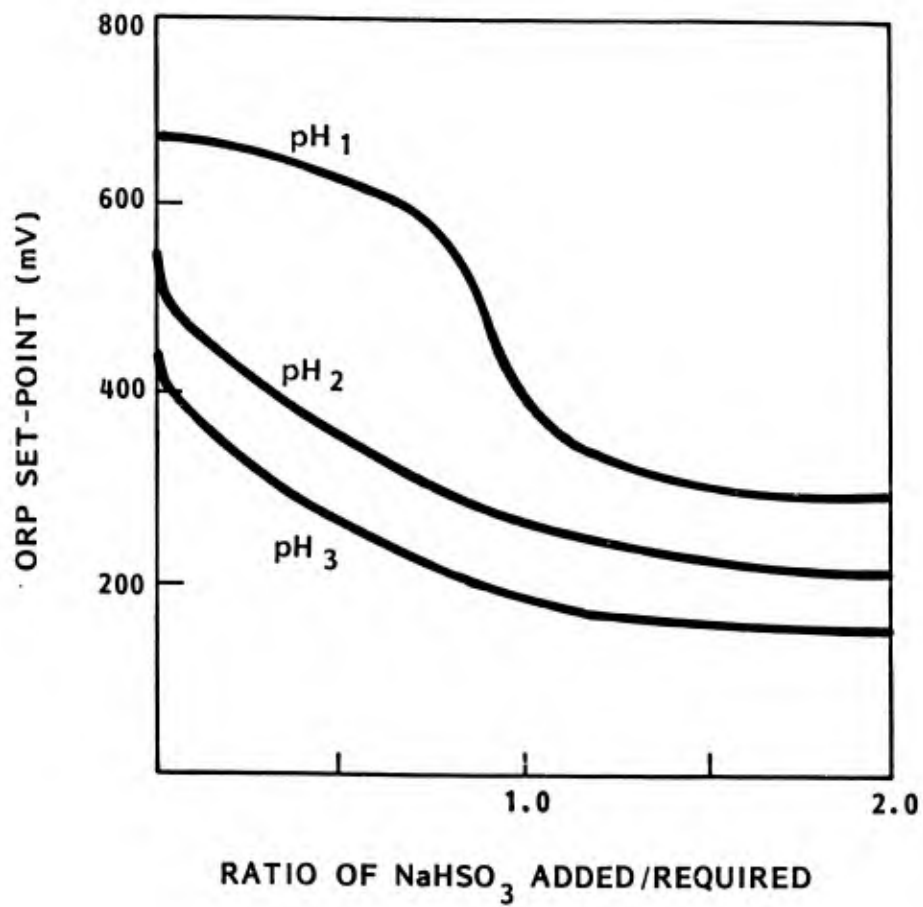

Figure 12. Effect of pH on ORP Control Set-Point for Chromate Reduction

Hach (or equivalent) sample analysis kits provide an inexpensive, easy-to-use method of verifying treatment system performance. Kits are available for analyzing chromium, as well as most other elements of interest in wastewater treatment systems.

System performance is usually more than adequate to meet effluent limitations if the unit is maintained and properly controlled. Table 8 gives some typical performance levels reported in the literature.

TABLE 8. SUMMARY OF TREATMENT LEVELS REPORTED FOR HEXAVALENT CHROMIUM WASTES

Reduction	Chromium <sup>+6</sup> Concentration (mg/l)	
	Initial	Final
Sulfur dioxide	--	0.3-1.3
Sulfur dioxide	1,300	1.0
Sulfur dioxide	--	0
Sulfur dioxide	--	0.01
Sulfur dioxide	--	0.05
Sulfur dioxide	0.23-1.5	0.1
Bisulfite	140	0.7-1.0
Bisulfite	--	0.05-0.1
Bisulfite plus hydrazine	8-20.5	0.1
Metabisulfite	70	0.5
Metabisulfite	--	0.025-0.05
Metabisulfite	--	0.1
Metabisulfite	--	0.001-0.4

Source - Reference 7

#### 4. Residuals Generated

The chemical reduction of hexavalent chromium to the trivalent form does not in itself produce any solid waste residue, but the standard method of precipitating the trivalent chromium as chromic hydroxide, a subsequent process step, contributes to the sludge volume.

#### 5. Cost Factors

Investment costs for chromium reduction units using sodium bisulfite are primarily a function of the volumetric flow rate of the wastewater. Table 9 gives cost estimates for systems designed to process 10 and 33 gal/min, based on the system shown in Figure 11. The reaction vessel is sized for 30

minutes residence time with a safety factor of 25 percent. This residence time should be sufficient to allow an operating pH between 2.5 and 3.0. The costs in Table 9 exclude those for building space and water segregation and collection. Particularly for the smaller system, pre-engineered package systems may be available at investment costs lower than those given in Table 9 (Reference 8).

TABLE 9. CHROMIUM REDUCTION UNIT COST

Item	Installed Cost (\$) <sup>a</sup>	
	10 gal/min	33 gal/min
Treatment tank (FRP)	2,400	4,800
Reagent storage tanks (FRP)	2,000	3,000
Agitators (3)	2,000	4,000
Pumps (3)	3,600	4,500
pH controller/probe	1,000	1,000
ORP controller/probe	1,200	1,200
Piping and valves	1,200	1,800
Electrical wiring	1,800	1,800
Total	15,200	22,100
Contingency (25%)	3,800	5,500
Total installed cost	19,000	27,600

<sup>a</sup>Includes field labor, equipment installation, support and shipping.

Many plants do not segregate chromium waste streams from the rest of the wastewater and, consequently, must process all waste streams (except for cyanide waste streams) through the chemical reduction system. This approach has three direct disadvantages:

- Higher waste treatment equipment costs
- Significantly higher consumption of treatment reagents
- Significantly higher volume of sludge generated (mainly with lime systems)

The practice is not recommended unless waste segregation is not feasible. Fixed operating costs are primarily for electricity, operating labor, and maintenance materials and labor. Major variable operating costs are for chemical reagents

and for disposal of solid waste generated. Table 10 gives a basis for calculating the chemical cost for a system using sulfur dioxide or sodium bisulfite as the reducing agent. Assuming a concentration of 12 mg/l of hexavalent chromium, the treatment costs would be \$0.05 and \$0.15 per 1000 gallons for sulfur dioxide and sodium bisulfite, respectively.

TABLE 10. CHEMICAL COST FACTORS FOR CHROMIUM REDUCTION

Item	Amount
Reagent cost:	
Sulfur dioxide (gas cylinders)	\$0.10/lb
Sodium bisulfite (100-lb bags)	\$0.25/lb
Sulfuric acid (carboys)	\$0.06/lb
Reagent consumption: <sup>a</sup>	
Sulfur dioxide reduction:	
Sulfur dioxide	2.8 lb SO <sub>2</sub> /lb Cr <sup>+6</sup>
Sulfuric acid	0.4 lb H <sub>2</sub> /SO <sub>4</sub> /1,000 gal
Sodium bisulfite reduction:	
Sodium bisulfite	4.4 lb NaHSO <sub>3</sub> /lb Cr <sup>+6</sup>
Sulfuric acid	2.1 lb H <sub>2</sub> SO <sub>4</sub> /lb Cr <sup>+6</sup>
Sulfuric acid	0.4 lb H <sub>2</sub> SO <sub>4</sub> /1,000 gal
Reduction Cost at 12 mg/l Cr <sup>+6</sup> :	
Sulfur dioxide	\$0.05/1,000 gal
Sodium bisulfite	\$0.15/1,000 gal

<sup>a</sup>Based on 50 per cent above stoichiometric excess of reducing compound.

## C. CYANIDE OXIDATION--ALKALINE CHLORINATION

### 1. Summary and State of Technology Development

Virtually all treatment of dilute cyanide waste streams is accomplished by alkaline chlorination. The process has been in commercial use for over 25 years. If properly designed and maintained, the process will oxidize cyanides, which are amenable to chlorination, to less than 1 ppm.

### 2. Process Description

Destruction of cyanide by chlorination can be accomplished by direct addition of sodium hypochlorite ( $\text{NaOCl}$ ), or by addition of chlorine gas plus sodium hydroxide ( $\text{NaOH}$ ) to the waste. Sodium hydroxide reacts with the chlorine to form sodium hypochlorite. Selection between the two methods is based on economics and safety. The chemical costs for chlorine gas treatment are about half those of direct hypochlorite addition, but handling is more dangerous and equipment costs are higher (Reference 8).

The hypochlorite oxidizes cyanide to cyanate. This reaction is accomplished most completely and rapidly under alkaline conditions at pH 10 or higher. An oxidation period of 30 minutes to 1 hour is usually allowed. To avoid producing solid cyanide precipitates, which may resist chlorination, the wastewater should be continuously mixed during treatment.

The resulting cyanate is much less toxic than cyanide, but regulations require that it be further oxidized to carbon dioxide and nitrogen, which can be accomplished by additional chlorination.

Complete cyanide oxidation to carbon dioxide and nitrogen can be accomplished in a single-stage unit, provided the close pH control is maintained. After initial oxidation to cyanate, further oxidation to yield carbon dioxide and nitrogen will occur slowly over several hours at pH 10 or above.

The second stage of the reaction is usually accomplished in a separate reaction vessel. When the first stage is operated at a pH of 10.0 and the second stage at 8.5, the overall reaction rate is increased. Further, a potential hazard of oxidizing cyanide at a pH below 10 is the release of toxic cyanogen chloride ( $\text{CNCl}$ ). Cyanogen chloride is the intermediate product of the oxidation of cyanide to cyanate. It breaks down very rapidly at pH 10 or above and temperatures above  $20^{\circ}\text{C}$ . At lower pH or temperature, however, excess chlorine is needed to speed the breakdown.

Figure 13 shows a conventional stirred tank, two-stage cyanide oxidation system. The system features separate pH-controlled addition of sodium hydroxide and ORP-controlled

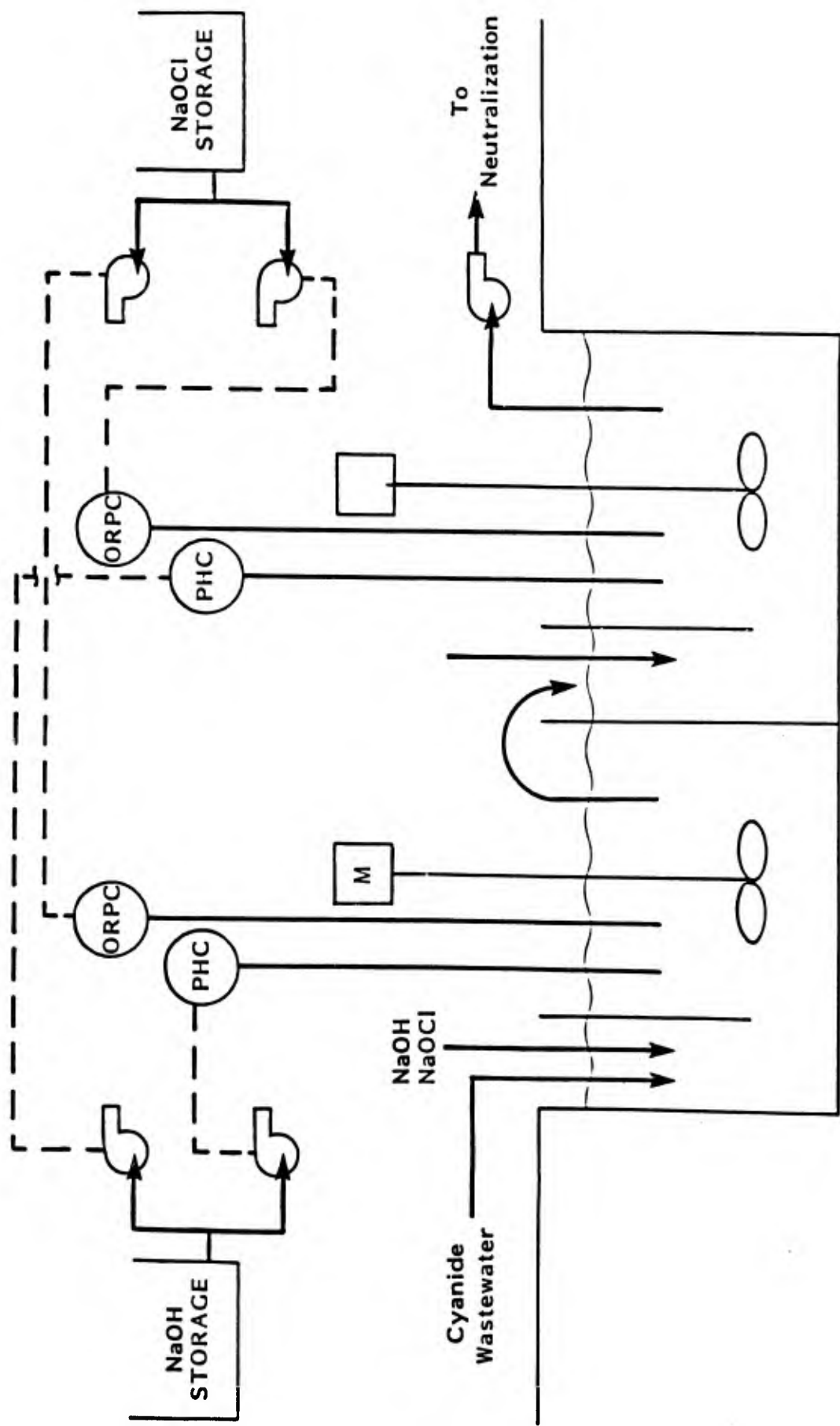
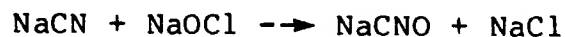

Figure 13. Two-Stage Cyanide Oxidation System

addition of sodium hypochlorite to each stage. Each stage should be designed to provide approximately 1-hour retention volume.

When sodium hypochlorite is used, the reaction in the first stage is:



and in the second stage,

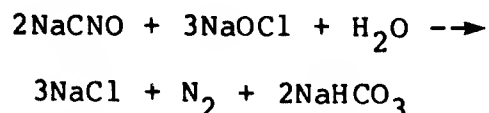

Sodium hypochlorite consumption is usually 25 to 100 percent greater than stoichiometric requirements. The excess is consumed by oxidation of organics and raising the valences of metals in the wastewater.

Use of chlorine gas for cyanide oxidation in a mixed tank reactor requires a chlorinator, unless there is a reaction tower in which the waste can make contact with the chlorine gas. (Reference 7) A two-stage system using this principle is shown in Figure 14.

### 3. Operation and Maintenance Demands and System Performance

Routine operation and maintenance activities include:

- Maintaining reagent supply
- Performing scheduled cleaning and calibration of pH and ORP probes
- Collection and analysis of treated samples to verify oxidation reaction completion
- Scheduled maintenance on pumps and mixers

The systems have generally proven reliable if well maintained. Use of a well-designed ORP control system is highly recommended. Most problems with the system focus on failures of this element. Figure 15 shows the response of various electrodes to the cyanide-to-cyanate reaction end point. The figure shows that the goldplated electrode, although more expensive, gives much better reagent addition control.

Operator training does not require learning of any sophisticated skills. Most procedures are routine and the tasks can be learned, even if not fully understood, by repetition.

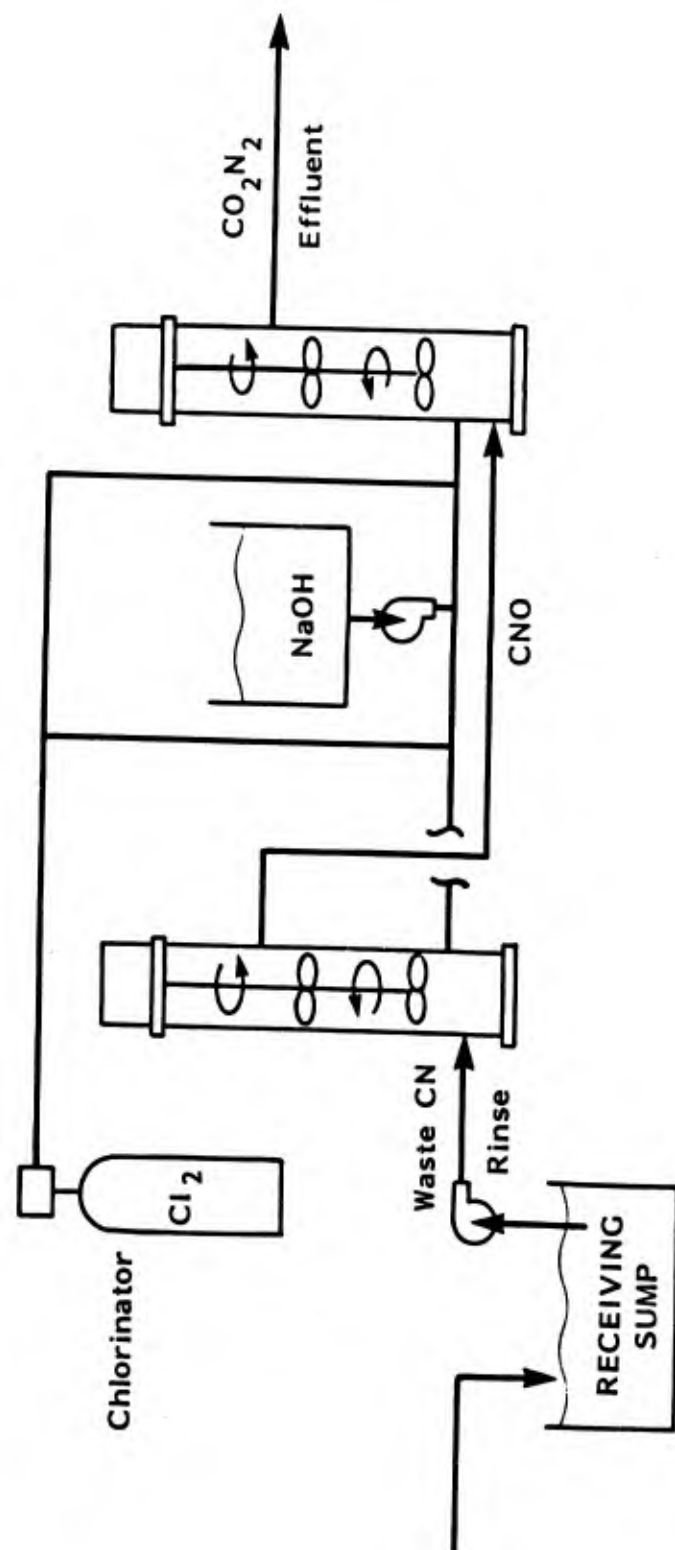

Figure 14. Reaction Tower-Type Two Stage Cyanide Oxidation System

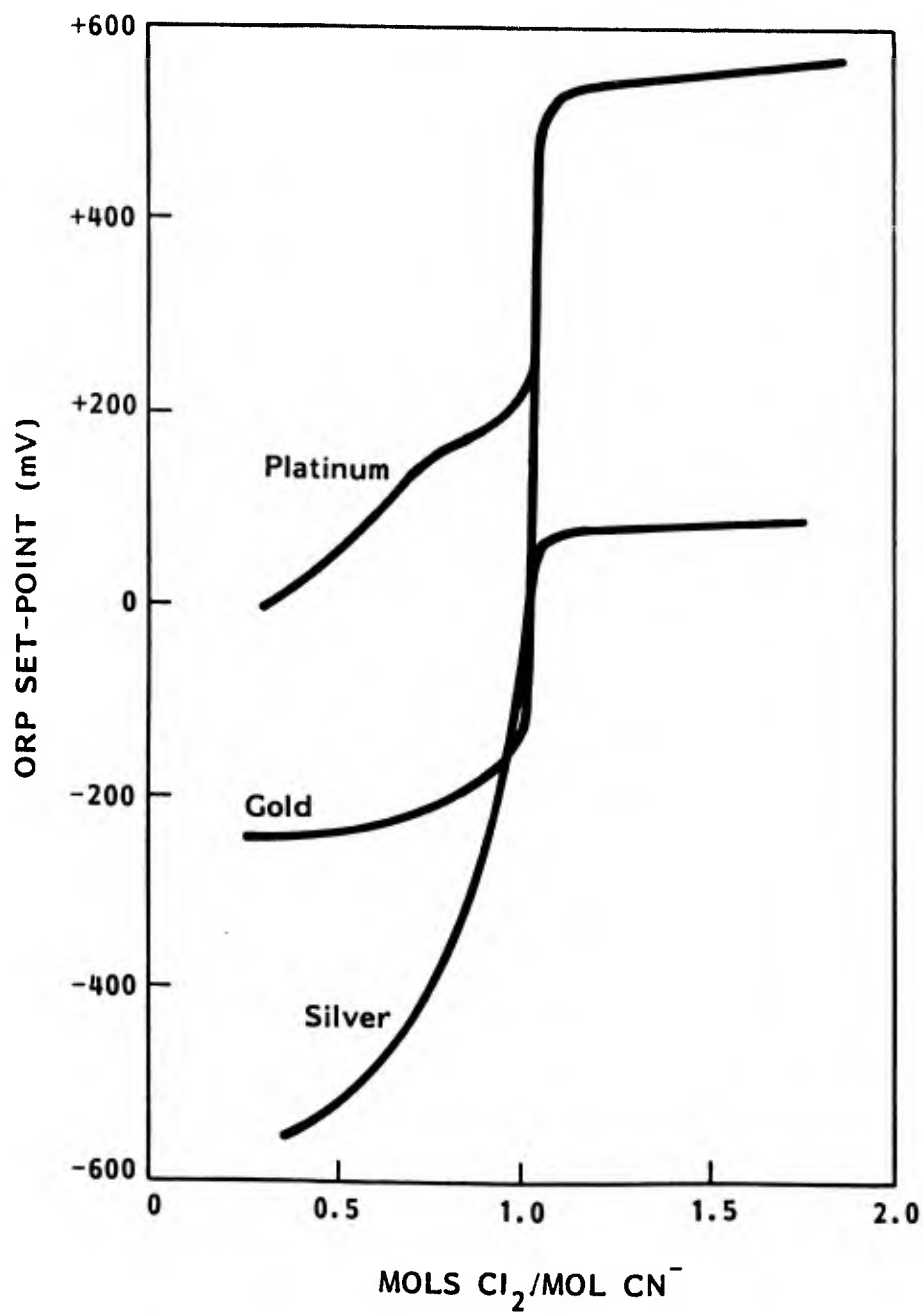

Figure 15. Response Curves of Available Electrodes for Cyanide to Cyanide Oxidation

Table 11 gives the performance of alkaline chlorination systems as reported in the literature for oxidation of cyanides. The low residual levels in the treated effluents suggests that the wastes did not contain stable ferrocyanide or other cyanide complexes not amenable to chlorination.

TABLE 11. TREATMENT LEVELS FOR CYANIDE WASTEWATERS

Treatment Process	Cyanide Concentration (mg/l)		Percent Removal
	Initial	Final	
Alkaline chlorination <sup>a</sup>	--	1.7	--
Alkaline chlorination <sup>a</sup>	--	0.1	--
Alkaline chlorination <sup>b</sup>	--	0.4	--
Alkaline chlorination <sup>b</sup>	700	0.0	100
Alkaline chlorination	32.5	0.0	100
Alkaline chlorination	5.1	0.1	98

<sup>a</sup>Single-stage chlorination.

<sup>b</sup>Two-stage chlorination.

Alkaline chlorination cannot oxidize stable cyanide complexes such as ferrocyanides. As most cyanide discharge limits are based on total cyanide levels (rather than cyanide amenable to chlorination), contamination of the cyanide wastewater with iron- or nickel-bearing wastes should be avoided. It should be noted that the only treatment process that has reported any success with oxidation of ferrocyanides requires the combination of ultraviolet light and a chemical oxidant to initiate the decomposition (Reference 9).

#### 4. Residuals Generated

Alkaline chlorination of cyanides either to cyanates in a one-stage reaction or to CO<sub>2</sub> and N<sub>2</sub> in the two-stage reaction does not influence the solid waste generation of the treatment system. The use of either sodium hypochlorite or chlorine results in soluble gaseous reaction products. The treatment, however, will add to the dissolved solids content of the treated effluent.

## 5. Cost Factors

Investment cost for alkaline chlorination two-stage cyanide oxidation treatment systems relates primarily to the volumetric flow rate of the wastewater that must be processed. Table 12 gives the cost for 10 and 33 gal/min systems. The reaction vessels were sized for 1-hour retention volume in each stage with a 25-percent safety factor. The cost, which excludes any cost for building space and collection of waste streams, is essentially for the system shown in Figure 13. The investment cost is given for a system using hypochlorite as the treatment reagent. For the smaller unit (10 gal/min) a pre-engineered package unit may represent a less expensive alternative. Figure 16 shows the installed cost of systems over a range of flow rates.

TABLE 12. CYANIDE OXIDATION UNIT COST

Item	Installed Cost <sup>a</sup>	
	10 gal/min	33 gal/min
Treatment tank (FRP)	6,000	10,000
Reagent storage tanks (2) (FRP)	2,000	3,000
Agitators (4)	2,000	3,000
Pumps (5)	6,000	7,500
pH controller/probes (2)	2,000	2,000
ORP controller/probes (2)	2,400	2,400
Piping and valves	2,400	3,600
Electrical	3,000	3,000
<b>Total</b>	<b>25,800</b>	<b>34,500</b>
Contingency (25%)	<u>6,500</u>	<u>8,600</u>
<b>Total installed cost</b>	<b>32,300</b>	<b>43,100</b>

<sup>a</sup>Includes field labor, equipment installation, and support and shipping.

Source: Vendor Quotes

Fixed operating costs are primarily for electricity, operating labor, maintenance items, and maintenance labor. The major variable operating cost is for reagent consumption, which is primarily a function of the mass flow rate of cyanide in the wastewater. Table 13 gives the reagent costs and consumption factors for treatment systems based on hypochlorite and chlorine. Assuming a cyanide concentration of 15 ppm in the wastewater, the reagent cost would be \$0.50 and \$0.20 per 1,000 gallons for sodium hypochlorite and chlorine, respectively.

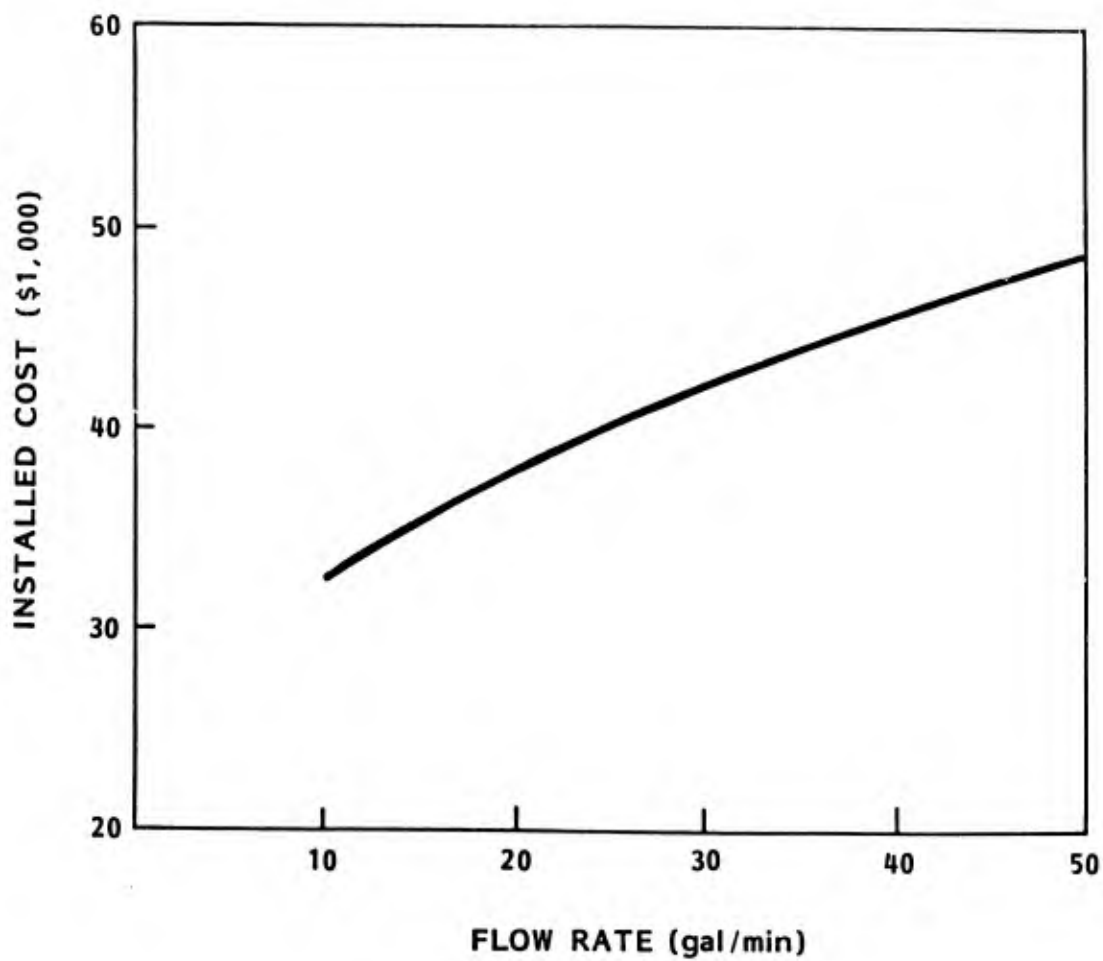

**NOTE:** Includes field labor, equipment installation, and support and shipping.

Figure 16. Installed Cost of Two- Stage Cyanide Oxidation Unit

TABLE 13. TREATMENT COST FACTORS

Item	Amount
Reagent Costs <sup>a</sup>	
Chlorine (gas cylinders)	0.10/lb
Sodium hydroxide (carboys, 50% NaOH)	0.09/lb
Sodium hypochlorite (15% NaOCl, 1,000-gal increments)	0.40/lb
Consumption factors <sup>b</sup>	
Chlorine	10 lb Cl <sub>2</sub> /lb CN
Hypochlorite	7 lb NaOH/lb CN 10 lb NaOCl/lb CN
Cost factors	
Chlorine	\$1.63/lb CN
Hypochlorite	\$4/lb CN

<sup>a</sup>\$/lb of active ingredient.

<sup>b</sup>Based on 50% excess oxidizing reagent required.

#### D. METAL HYDROXIDE PRECIPITATION

##### 1. Summary and State of Technology Development

Hydroxide precipitation is the standard method of removing heavy metals from wastewater. The process allows both neutralization of wastewater to within the range acceptable for discharge (pH 6 to 9) and reduction of the solubility of any metals present.

Either of two alkalies is used, sodium hydroxide (NaOH) or lime (Ca(OH)<sub>2</sub>). Each has advantages and disadvantages and both are used extensively. The sophistication of the pH control required depends on how narrow the pH range is for acceptable metal removal and how variable the incoming wastewater demand is for alkali. The pH control can be enhanced by use of two separate stirred tank reactors in series (two-stage system) or by use of more sophisticated control loops on the reagent feed system.

The following are limitations of hydroxide precipitation (Reference 10):

- The process cannot precipitate metals to low levels of solubility in the presence of chelating compounds.

- The metal hydroxide sludge resulting from treatment of electroplating wastewater has been generally classified as toxic and hazardous and must be disposed of under the provisions of RCRA.
- Different metal hydroxides are amphoteric; that is, solubility is at a minimum at a specified pH and increases if pH is higher or lower. The solubility minimum for different metals occurs at different pH levels.

In many cases, the limitations of the process can be accommodated by proper waste management or by use of chemical additions.

## 2. Process Description

Wastewater from metal finishing operations is composed of three waste streams: wastes containing cyanides; wastes containing hexavalent chromium; and wastes that contain acid, bases, metal salts, and other compounds. Cyanide wastes are segregated from other waste streams and pretreated to oxidize the cyanide content. Chromate wastes may be segregated and pretreated, but often the preponderance of chromate-containing wastes makes this practice difficult. In such cases, all non-cyanide wastes are pretreated to reduce the hexavalent chromium ( $\text{Cr}^{+6}$ ) to the trivalent state ( $\text{Cr}^{+3}$ ). After the required pretreatment, all wastewaters are mixed together in a common neutralization-precipitation unit, which maintains the pH at the level that yields the minimum solubility of the metals present.

Most combined waste streams are acidic before neutralization. Consequently, many facilities do not even provide for acid addition to lower the pH. The primary reagent is the base, and both caustic soda and hydrated lime are used extensively.

Hydrated lime has the advantage of lower cost per unit of neutralizing capacity, and the metal hydroxide precipitants, because of co-precipitation of calcium solids, have much faster settling rates. The settled sludge from lime treatment is higher in solids content and much more amenable to dewatering. On the other hand, lime takes longer to react in the neutralizer than caustic soda, has a more complicated feed system and, most significant, generates a considerably higher mass of sludge solids (Reference 8). Figure 17 shows the process schematic of a single-stage neutralizer with provisions for adding both acid and base. With a single-stage system, proportional control for reagent addition is required to maintain a reasonably constant effluent pH. The elevation of the reagent storage and gravity feeding through a proportioning valve is one mode of control. Use of variable speed pumps will achieve the same level of control. If incoming wastes are subject to wide swings in

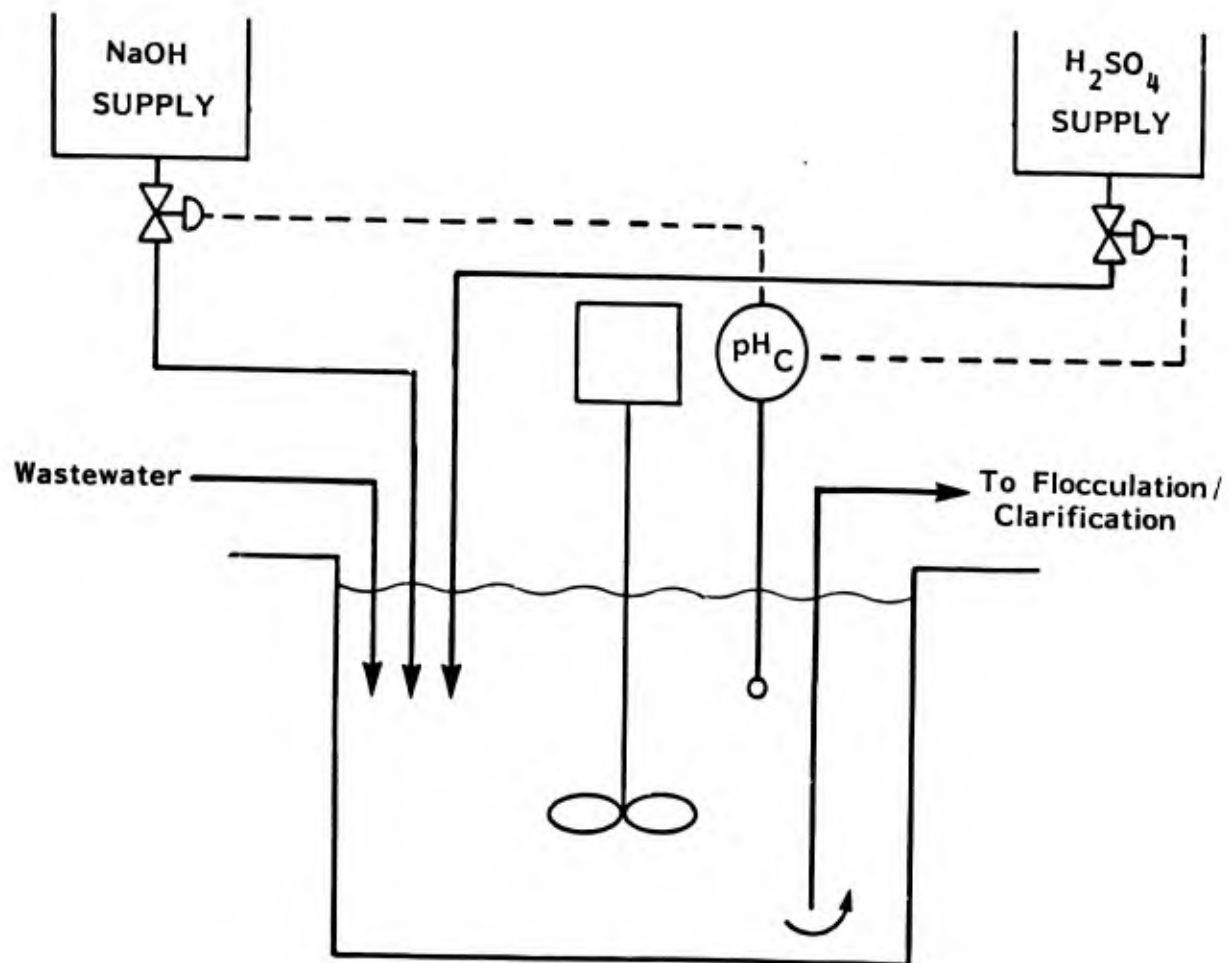

Figure 17. Single-Stage Neutralizer

reagent demand, a two-stage neutralization system should be used. The first stage would control at a pH of approximately 6 to 7.

Required residence volume in the neutralizer depends on reagent. A minimum of 15 minutes residence volume is required for sodium hydroxide; with lime as the alkali, a minimum of 30 minutes is required (Reference 5).

### 3. Operation and Maintenance Demands and System Performance

Operation and maintenance of a metal hydroxide precipitation/neutralization system requires no skills beyond those normally associated with wastewater treatment operator training. Routine activities include:

- Maintaining acid and base reagent supply
- Performing scheduled cleaning and calibration of pH probes
- Collection of samples and sample analysis to verify system performance
- Scheduled maintenance on pumps, mixers, and so forth.

Hach (or equivalent) sample analysis kits provide an inexpensive, easy-to-use method of verifying treatment system performance. For the metal precipitation part of the process, a sample of neutralizer effluent should be filtered and then tested for the level of metals present.

The level of residual dissolved metals after pH adjustment depends on the pH control set-point, the mixture of metals in the wastewater, and whether any compounds are present that interfere with metal hydroxide precipitation. Common metal complexing compounds, which will cause interference, include ammonia, electroless plating additives, and cyanides.

The removal efficiency of metal hydroxide precipitation is given in Table 14. The data are from tests on contrived wastewater neutralized with lime. The wastewater had a "normal" background concentration of nonmetal ions. At pH values of 8.4, 8.8, and 9.2 the level of dissolved metals was uniformly low. Because of this uniformity, the optimum pH for this wastewater was determined by the ability to flocculate and settle the precipitation solids. The polymer flocculant used in these tests gave superior performance at a pH of 9.2.

### 4. Residuals Generated

Precipitation of metals as hydroxides generates a sludge generally classified as hazardous by RCRA regulations.

The quantity of sludge generated depends to a great degree on whether lime or sodium hydroxide is used as the neutralizing reagent. The raw wastewater described in Table 14 was neutralized with both NaOH and Ca(OH)<sub>2</sub> to a pH of 9.2. For NaOH, the precipitation resulted in 230 mg/l of dry solids of wastewater treated. The corresponding number for Ca(OH)<sub>2</sub> was 1,370 mg/l (Reference 11).

TABLE 14. METAL SOLUBILITY AS A FUNCTION OF pH

Metal	Dissolved Metal Concentration (mg/l)			
	Raw Wastewater	pH 8.4	pH 8.8	pH 9.2
Chromium (total)	45.0	0.1	0.11	0.1
Cadmium	1.0	0.02	0.02	0.02
Copper	25.0	0.02	0.03	0.03
Nickel	10.0	0.20	0.20	0.20
Iron	20.0	NM	NM	NM

NOTE: NM = not measured.

Source: Reference 11

The lime treatment generated approximately six times the amount of solids. The floc formed during the treatment was also significantly different; the NaOH precipitants formed a light, fluffy floc that compacted poorly and was easily disturbed. The Ca(OH)<sub>2</sub> floc settled well to form a relatively dense sludge layer. In fact, despite the lower solids generation rate, the volume of the NaOH precipitants was three times that of the Ca(OH)<sub>2</sub> precipitants after 30 minutes of settling (Reference 11).

#### 5. Cost Factors

Investment costs for a neutralization/metal hydroxide precipitation unit will depend on:

- Volume of wastewater treated
- Sophistication of control system, for example, multistage system, proportional reagent control
- Neutralizing reagent chosen

Table 15 gives the cost for systems designed to treat 30 and 100 gal/min. Each system is a two-stage unit using lime, with the capability to add either acid or base in the second

stage. Each stage has 15 minutes retention volume with a safety factor of 25 percent. The cost for a 30-gal/min system is \$20,000; a 100-gal/min unit would cost \$30,000. By comparison, vendor quotes for a pre-engineered package system employing a single-stage reactor, with sulfuric acid and sodium hydroxide reagent addition, were \$9,000 for a 20-gal/min unit and \$16,000 for a 100-gal/min unit. The systems are modular and are designed for 15 minutes retention volume. Figure 18 shows the cost for both systems over a range of flowrates.

TABLE 15. NEUTRALIZATION/HYDROXIDE PRECIPITATION UNIT COST

Item	Installed Cost <sup>a</sup>	
	30 gal/min	100 gal/min
Two-stage treatment tank (FRP)	4,000	8,000
Lime feed (includes tank, agitator and 2 automatic control valves)	2,000	3,000
Acid feed (includes tank, agitator and automatic control valves)	1,500	1,500
Agitators (2)	2,500	4,000
pH controller/probes (2)	2,000	2,000
Sump Pumps (2)	2,000	3,000
Piping and Valves	1,000	1,500
Electrical	<u>1,000</u>	<u>1,000</u>
Total	16,000	24,000
Contingency (25%)	<u>4,000</u>	<u>6,000</u>
Total installed cost	20,000	30,000

<sup>a</sup>Includes field labor, equipment installation and support, and shipping.

Source: Vendor Quotes

Operating costs are primarily for labor and reagents. If the system is well designed, 1 hour of operator attention per shift should be adequate. Reagent demand for neutralization is highly variable, depending on plating processes, water hardness, pretreatment systems, and other site-specific factors. Except in unusual circumstances, the chemical cost to operate a hydroxide neutralization/precipitation system ranges from \$0.15 to \$0.50 per 1,000 gallons for NaOH and is approximately half that for lime systems (Reference 5).

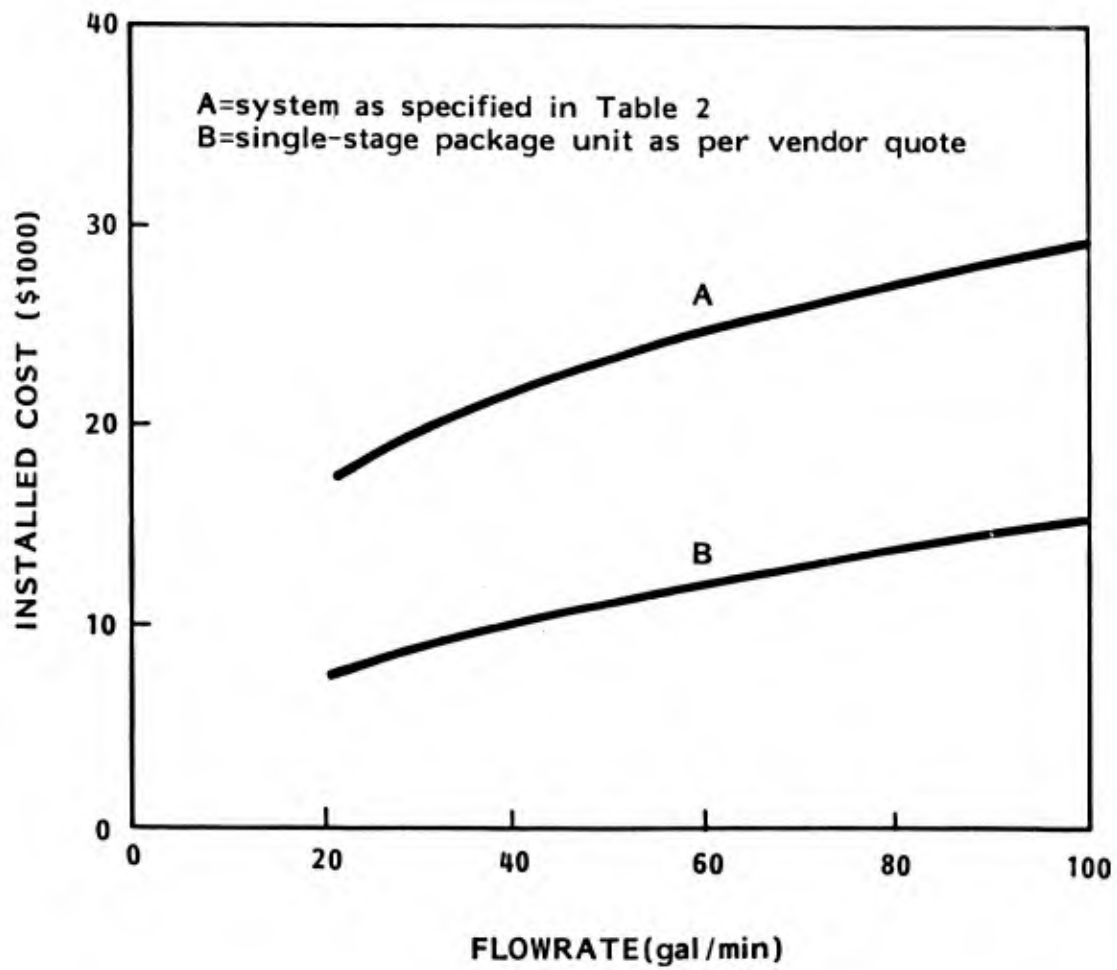

Figure 18. Cost of Neutralization/Hydroxide Precipitation Unit

## E. FLOCCULATION/CLARIFICATION

### 1. Summary and State of Technology Development

Removal of solids by gravity settling (clarification) is the most common method of separating insoluble particles from a waste stream before discharge. Clarification is a relatively simple process that relies on a density difference between the particles and water and the presence of gravity. However, it is often the unit operation of the waste treatment process most subject to upsets. With effluent limits placing strict control on the level of suspended solids in the wastewater, many modifications to the original circular clarifier have resulted from research and development activities. The two most successful approaches include the sludge blanket clarifier and the plate settler. In the sludge blanket unit, the clarifier inlet first passes through a sludge blanket of agglomerated particules. The mixing tends to promote particle growth and reduce the concentration of slow-settling particle fines. The plate settler relies on a series of inclined plates between which the wastewater flows in an upward direction. In essence, the particles must only settle a few inches before impinging on the plate surface. The particles then slide down the plate surface to the base of the separator. In a chamber of equal size, plate settlers can provide considerably greater effective settling volume than a conventional clarifier.

Much research and development also have been devoted to manufacturing chemical aids to foster particle growth before the wastewater enters the clarifier. By adding coagulating/flocculating agents in slow-mix reactors, the solids in a wastewater can be agglomerated into sturdy, fast-settling particles easily separated in the clarifier. Coagulants/flocculants in broad commercial use include inorganic chemicals such as alum and ferrous sulfate and a highly diverse range of organic polyelectrolytes with varying characteristics suitable for different wastewaters.

### 2. Process Description

Numerous process variations have been used in solids removal by gravity settling. Basically, they employ either some or all of the following steps:

- Coagulation chemicals are inorganic chemicals added in solution to the wastewater before precipitation of metals; generally alum, lime, or ferrous sulfate is used.
- Flocculation and coagulation both refer to the gentle mixing of water containing suspended particles to promote particle growth. Coagulation normally refers to the transition from small, nonsettling particle to suspended

solids that will gravity settle; flocculation refers to the growth of large, dense particle flocs that have rapid settling characteristics.

- Flocculants used today for metal hydroxide wastewater precipitants are almost exclusively organic polyelectrolytes. They are superior to inorganic compounds because both the charge density and valence have been synthetically introduced to the large polymer molecule. The length of the polymer also allows the particles to "knit" together. Normally, the appropriate polyelectrolyte is selected by testing a range of different polymers and observing settling behavior after mixing.
- Sludge recycle is the practice of gently mixing the wastewater with a slurry of previously settled sludge solids to promote particle growth. The recycle solids present a dense concentration of nucleation sites for any particle fines that might be present. The mixing can be accomplished in a separate stirred tank before the clarifier or by passing the wastewater through the sludge blanket maintained in the clarifier.
- Settling chamber (clarification) refers to a quiescent flow condition with a hydraulic flow velocity sufficiently low to allow particles with some minimum settling velocity to separate from the water overflow. The solids collect in the base of the chamber.

Coagulants are used primarily for waste streams having dilute concentrations of constituents that precipitate during neutralization. The disadvantage is that coagulants add to the quantity of sludge generated by the wastewater treatment. If lime is used for neutralization, the resulting precipitation of calcium salts provides the coagulating effect.

Polyelectrolyte flocculants are added to the wastewater after neutralization and before clarification. A certain degree of mixing is required after addition of the polyelectrolyte before clarification. Depending on the type of clarifier used, a separate mixing zone may be required to flocculate the wastewater precipitants.

Clarifiers used for metal finishing come in three basic types (Reference 6):

- Basic settling chambers (Figure 19) are usually rectangular units where the feed is evenly distributed at one end and overflows at

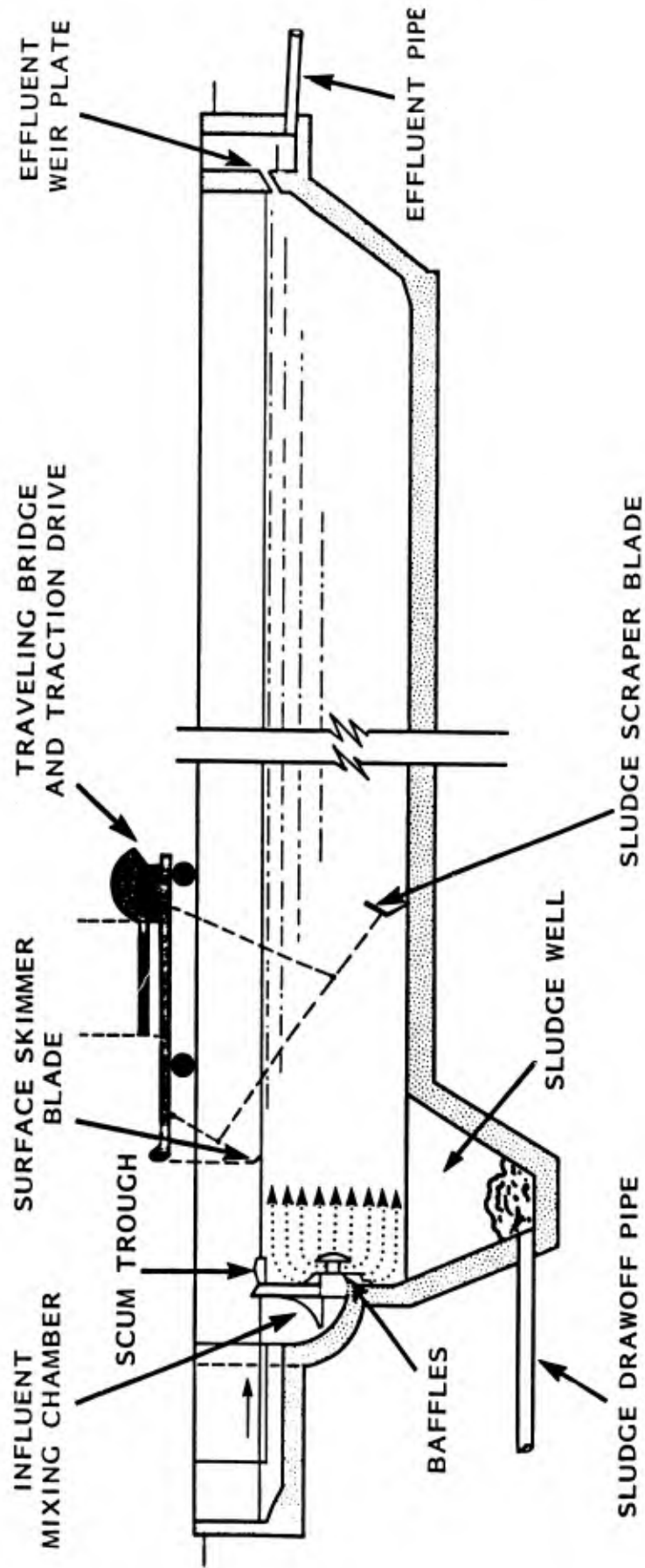

Figure 19. Rectangular Clarifier Basin

the other end. The solids, owing to their higher density, settle and are collected at the base of the unit. Normally, a rake or suction device is used to remove the collected solids. This type of unit is the most basic, and will often require a mixing zone to flocculate the particles before clarification. Circular units are also available in this type.

- Mixer clarifiers (Figure 20) provide a mixing chamber where the incoming feed is intimately mixed with the sludge blanket maintained in the unit. The unit is basically a flocculating chamber with sludge back-mixing and a settling chamber.
- Plate settlers (Figure 21) are based on the principle that if the path of the settling particle is shortened and the bottom of the container is brought close to it, the settling and separation of the particle will be accelerated. This design allows a significant reduction in equipment size because of the inclined plates that reduce the distance particles must fall to be removed. These units are often well suited for plating waste treatment applications because the space available to house the equipment is limited. Figure 22 illustrates a unit that employs both sludge blanket mixing and a plate settler.

### 3. Operation and Maintenance Requirements and System Performance

Maintaining clarifier performance usually starts with good waste management. Many things can interfere with the settling properties of the particle flocs, particularly if the system uses NaOH for neutralization. Oil and contaminants that generate gases are the most common causes of problems. The waste treatment operator should develop an operational history of the unit and relate cause and effect to clarifier upsets. Once a problem is explained, steps can be taken to avoid future occurrences.

Other operator duties depend on the mechanical complexity of the flocculation/clarification system. Preparation of polyelectrolyte solutions and maintenance of the mechanical equipment are common to all systems. Maintaining a sludge blanket (where appropriate) and properly scheduling sludge withdrawals from the unit are part of the operator duties.

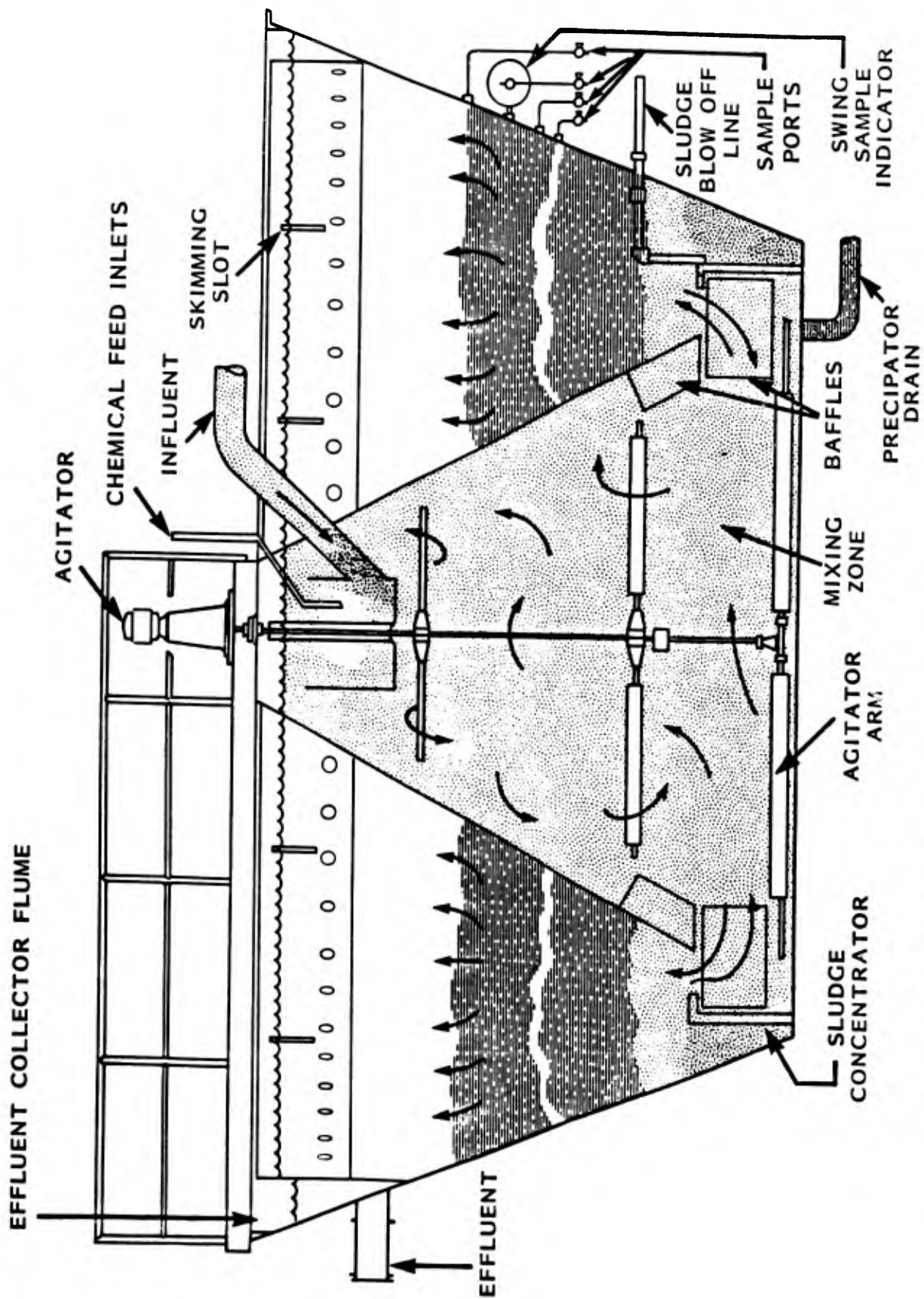

Figure 20. Solids Contact Clarifier with Sludge Blanket Filtration  
 (Courtesy of the Permutit Co.)

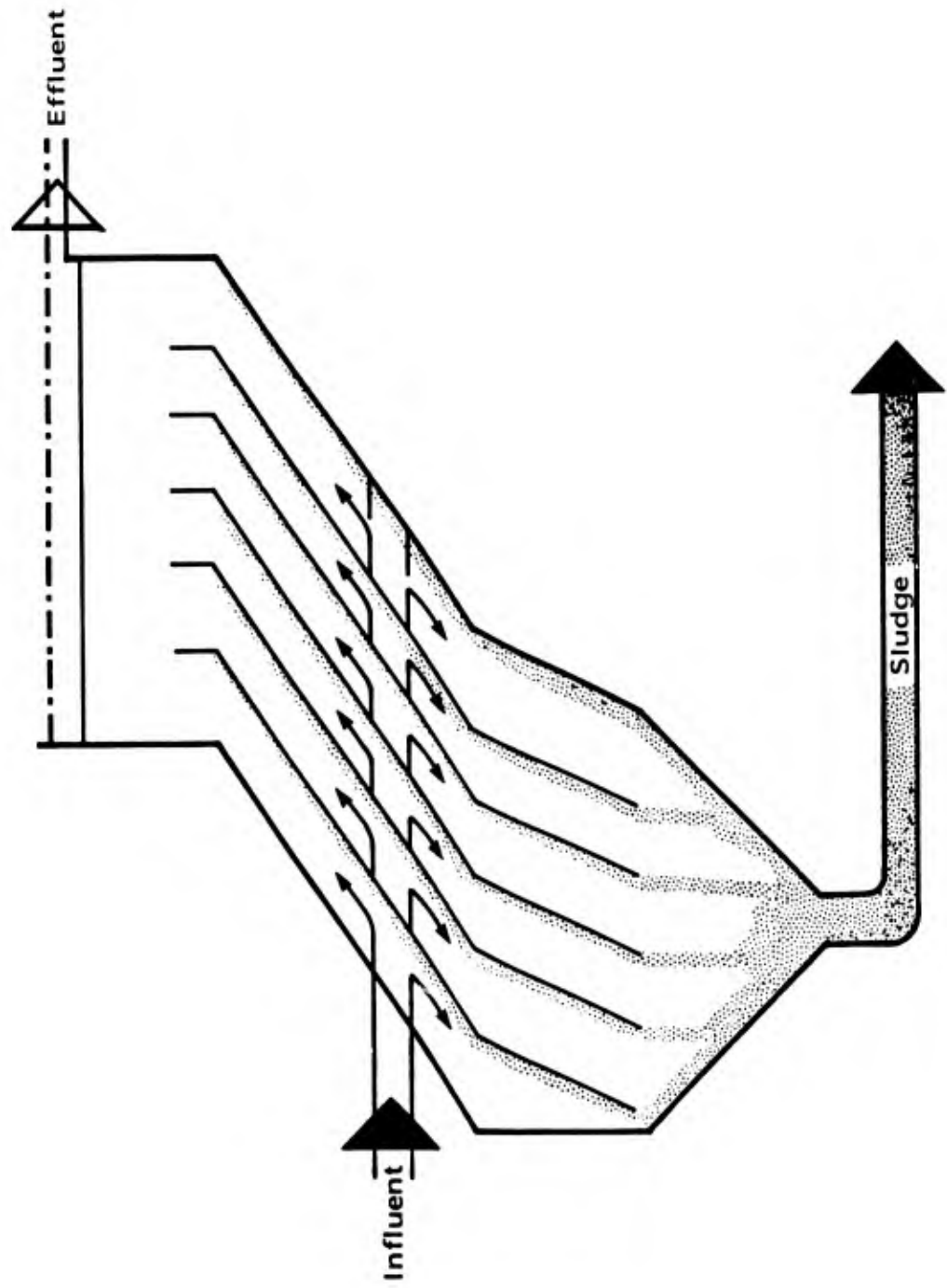
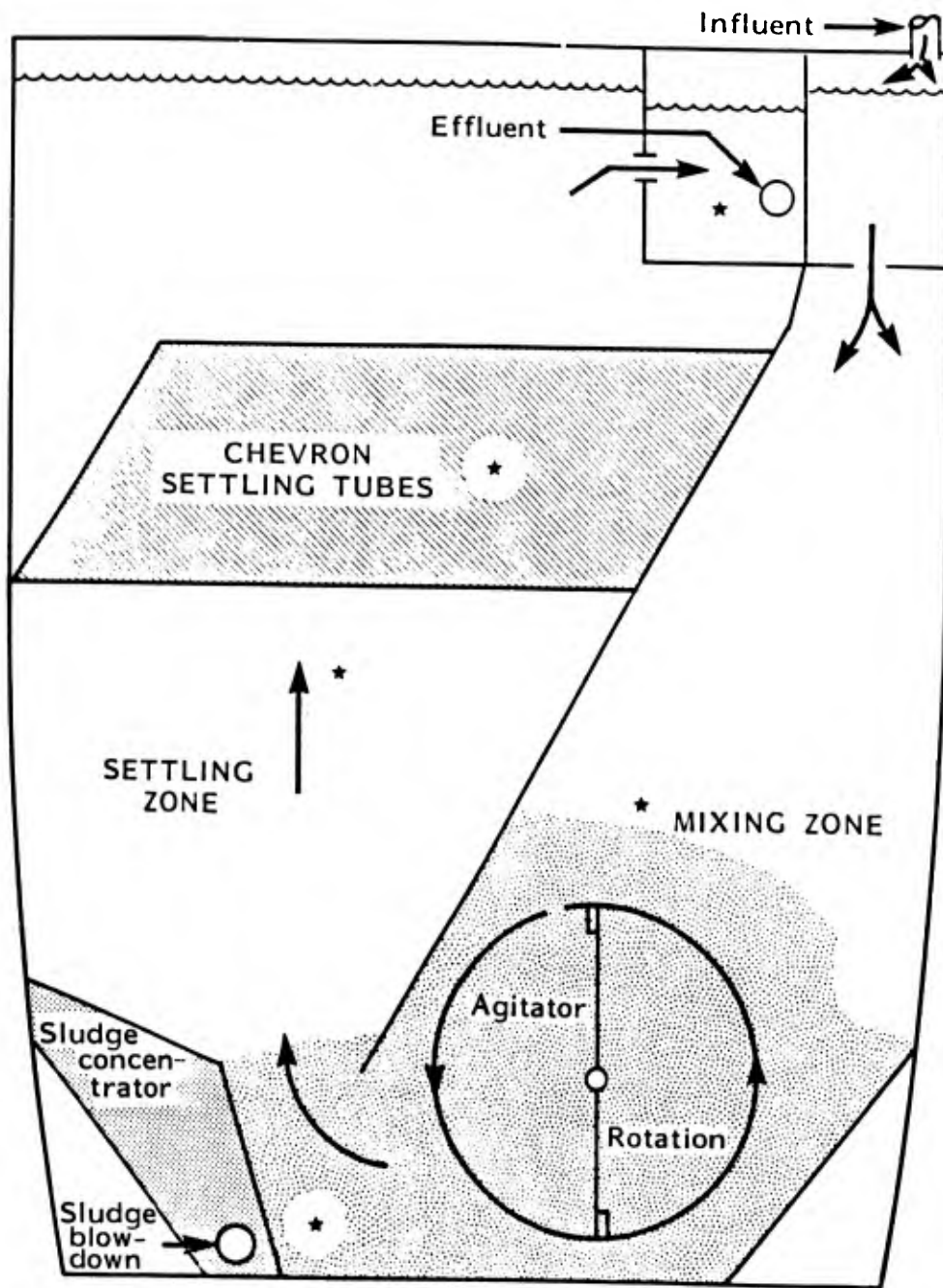

Figure 21. Inclined Plate Settler



LEGEND:  
 ★ = sampling port

Figure 22. Cross Section of Mixer/Clarifier  
 (Courtesy of Permutit, Co.)

Performance of clarifiers varies significantly depending on the type of waste, the design of upstream components, and the design of the clarifier itself. A well-operated clarifier will have 5 to 50 ppm of suspended solids in the overflow. Frequently, turbidity in the overflow contributes to the metal content of the discharge and makes strict pollutant guidelines difficult to meet. Consequently, many advanced waste treatment systems employ a polishing filter that uses a sand bed or mixed media filter to remove suspended solids not effectively removed by clarification.

#### 4. Residuals Generated

Flocculation/clarification does not in itself generate any residual. It is an agglomeration/separation process that separates solids generated by earlier unit processes. The underflow from a clarifier will contain the collected solids in a pumpable slurry with a solids concentration of 0.5 to 3.0 percent by weight. Normally the sludge drains into a sump and is dewatered before final disposal (Reference 13).

#### 5. Cost Factors

The design and complexity of the different units strongly influences the cost of the unit. Figure 23 shows the unit cost, as a function of the flow rate, of two types of units frequently used by plating facilities. The total cost of a solids separation system must also include the polyelectrolyte feed system, the flocculation equipment, the sludge receiving/storage volume, and any necessary pumps (Reference 8).

### F. SLUDGE DEWATERING

#### 1. Summary and State of Technology Development

Mechanical dewatering of dilute industrial waste treatment sludge is routinely practiced today. The justification for purchase of the dewatering equipment resides in either the cost saving for sludge disposal realized by the volume reduction of the waste or the unwillingness of local disposal sites to accept liquid wastes (Reference 13).

Metal finishing waste treatment sludge is generally classified as a hazardous waste in the RCRA regulations because of the metal content in the sludge and the potential for the sludge to leach the toxic metals if the sludge is disposed in an acid environment. Owing to the stringent requirements for hauling and disposal of hazardous wastes set forth in the regulations, the cost of disposal is significant. Chemical landfills charge in the range of \$0.25 to \$1 per gallon of waste they accept for disposal (Reference 13). Hauling costs can also be significant because of the scarcity of disposal sites; often wastes must be shipped a significant distance to a disposal site that is licensed to accept the waste. Also, many hazardous

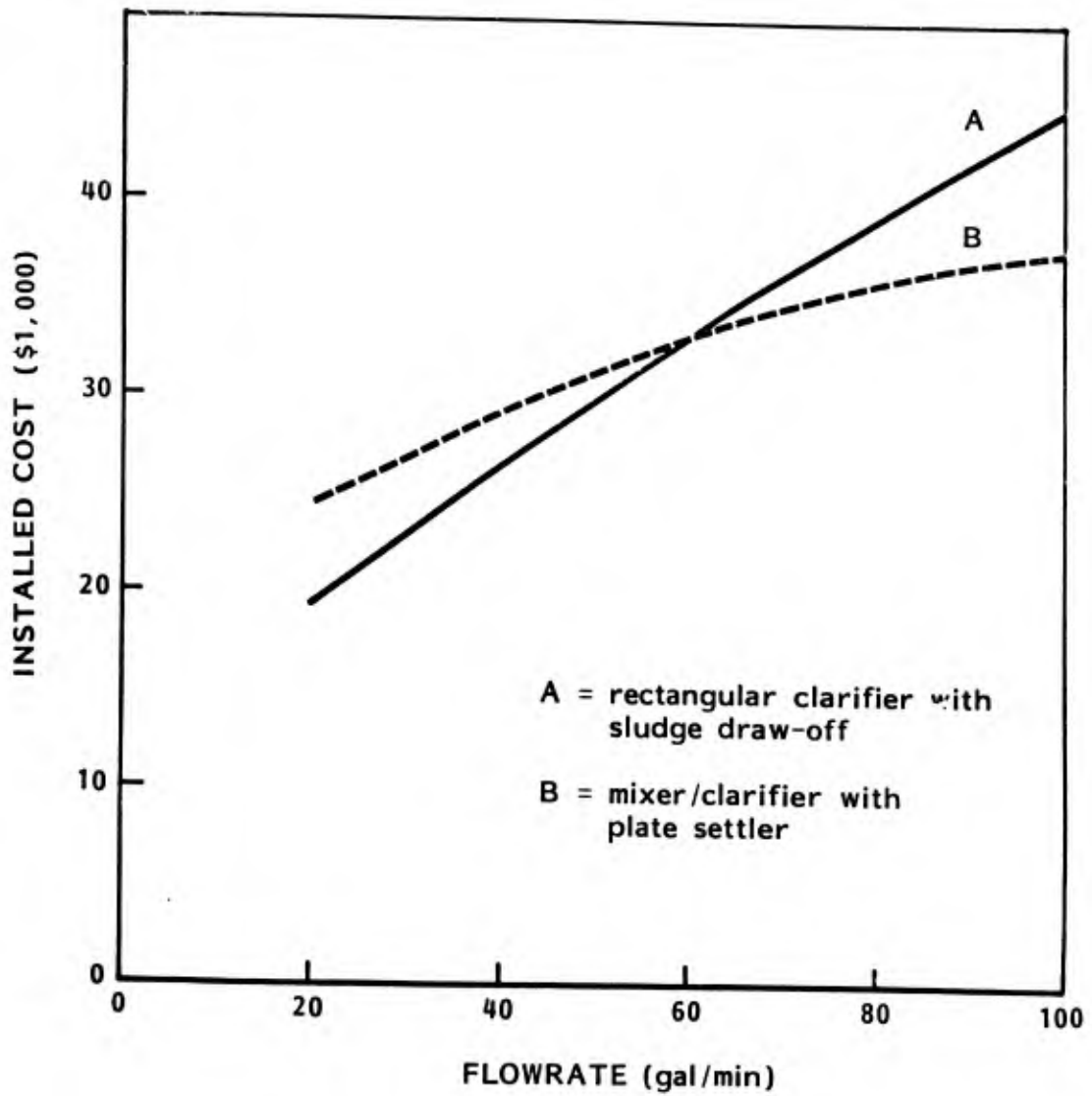

Figure 23. Installed Cost of Clarifiers

waste disposal sites will not accept or are prohibited the disposal of liquid sludges because of the potential for leachate formation. Consequently, firms use mechanical dewatering either to save money or make the waste suitable for disposal.

Of the types of dewatering equipment available, filter presses are usually the least expensive to install. Filter presses have further advantages in their mechanical simplicity and in their ability to achieve higher cake solids concentrations than other dewatering equipment types. Good performance with a filter press requires a sludge with good filtration characteristics. Sludges that have highly compressible, delicate particles or that tend to blind the media are not well suited for equipment of this type.

Poor-filtering sludges can be dewatered by centrifuges, pressure belt filters, or vacuum filters that use a precoat filter aid. These devices are more mechanically sophisticated than filter presses and usually cost more. Their automation, however, often reduces the need for operating labor.

## 2. Process Description

Mechanical dewatering devices are used to achieve a higher sludge solids concentration than can be obtained by gravity thickening. The following types of equipment can be used for mechanical dewatering of electroplating sludges:

- Filter presses
- Vacuum filters
- Centrifuges
- Compression filters

Criteria for selecting one of the foregoing devices for a specific application include:

- Sludge properties (solids concentration, particle size, compressibility)
- Volume of sludge to be dewatered
- Local disposal requirements

### a. Filter Presses

Filter presses come in two basic types: recessed plate and plate and frame. In both cases, the press is a series of parallel plates pressed together by a hydraulic ram, with cavities between the plates. The plates are recessed on each side to form the cavities in the recessed plate press. A frame of equal dimension is placed between flat plates in the plate-and-frame press (Figure 24). The plates come in a variety of

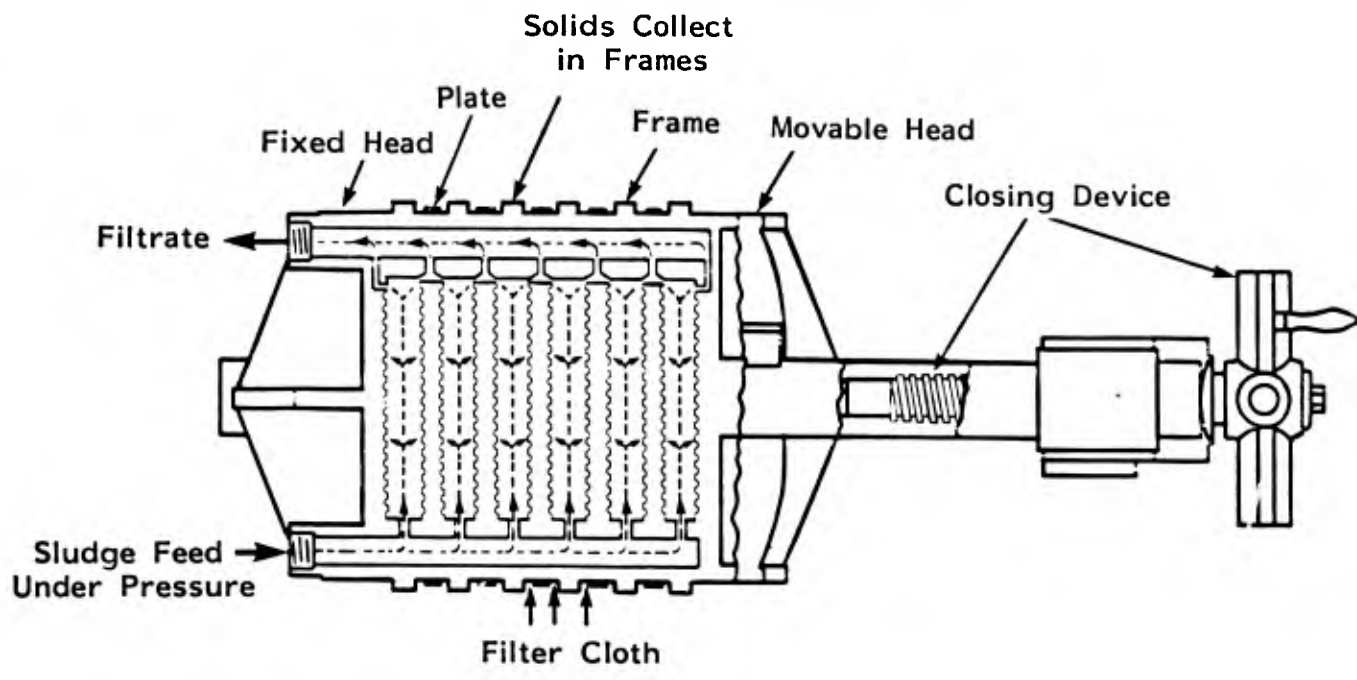

Figure 24. Plate-and-Frame Filter Press

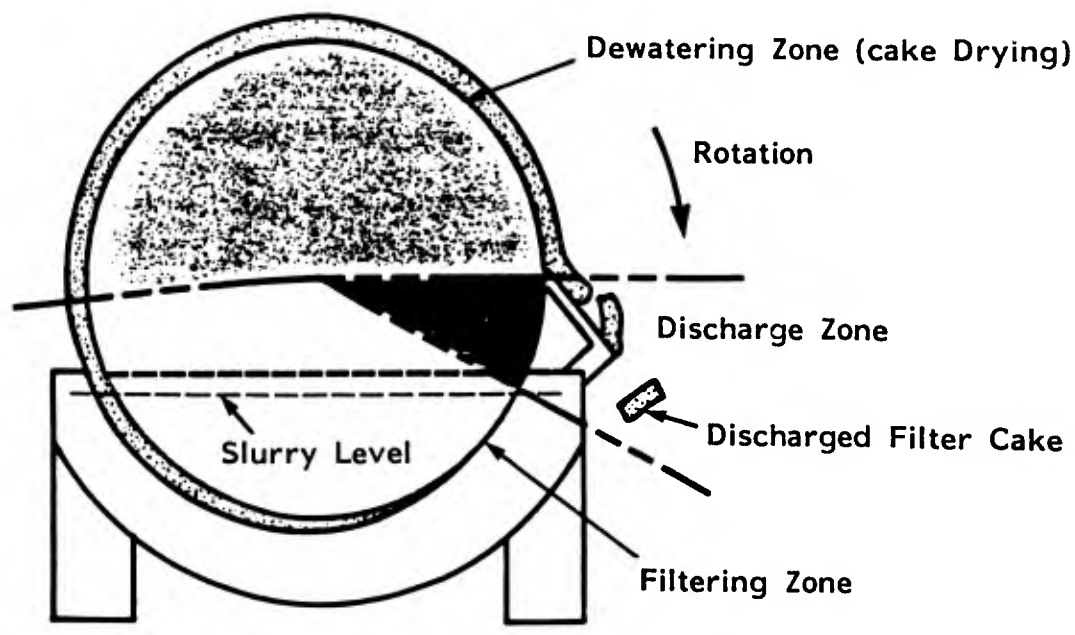

Figure 25. Rotary Vacuum Filter

materials; originally they were fashioned from wood, later from steel or ductile iron. Plates in predominant use today are made of light weight, chemically durable polypropylene or fiber-reinforced polyester.

A filter press is a batch unit. At the start of the cycle, slurry is pumped into the cavities through a port that runs through the bank of plates. When the cavities are full, the pressure forces the filtrate through the filter media, along the drainage surface of the plates, into orifices that are located in the corners of the plates and connected to the filtrate port. The process continues until the cake solids in the cavities thicken to a degree such that, at the pressure limit of the press, only a small volume of filtrate is being produced. The pump is shut off at this point, the ram is withdrawn, and each cavity is emptied individually. The press is then closed and the cycle begins again. Usually the filter cakes are dropped into a hopper under the press or are transported to a hopper by a screw conveyor, which also breaks up the cakes.

The filter press has a number of advantages over other filtration equipment. Filter presses can operate well at variable or low feed solids concentrations. They can produce a very dry cake because of the high pressure differential they can exert on the sludge. Some commercial units are designed with a pressure limit of 225 lb/in<sup>2</sup> gauge and produce sludge cakes with solids content in the range of 50 to 70 percent by weight. Filter presses are mechanically reliable; the hydraulic ram and the plate shifting mechanism (which facilitates cake discharge on the larger units) are the only moving parts. Power consumption is low; the only significant power use is for feed pump operation (2 to 20 hp).

The disadvantages of the filter press include its batch operating cycle, the labor associated with removing the cakes from the press, and the downtime associated with finding and replacing worn or damaged filter cloths. At the end of each filtration cycle, about 30 minutes of operator labor will normally be needed to empty the press and start a new cycle. A filter press is usually sized to operate on a 4- to 8-hour cycle.

#### b. Vacuum Filters

The rotary drum (Figure 25) is the most common type of vacuum filter. The drum is positioned horizontally and rotates partly submerged in a vat filled with a slurry.

The surface of the drum, which is covered by a filter medium, consists of a series of horizontal panels. Vacuum is applied independently to each panel by pipes inside the drum; the pipes connect to a common vacuum source, usually provided by a vacuum pump.

The filter has three basic operating zones: filtration, cake drying (dewatering), and cake discharge. In the first zone, vacuum is applied as a section of the drum submerges in the slurry. A cake forms on the filter medium as the solids are captured, and the filtrate is drawn to the vacuum source. The vacuum is maintained as the drum section rotates out of the slurry into the second zone. The vacuum removes additional water and draws air through the cake to promote further drying. In the last zone, the cake is discharged when the vacuum is replaced with a blast of air that separates the cake from the medium.

Other means have been developed to facilitate discharge of the filter cake. In one variation, a series of parallel strings, tied around the drum, separates from the drum in a tangential plane at the discharge point, lifting the filter cake from the medium. The strings pass around a roller and the cake separates from the strings and is discharged. In another variation, the medium is separated from the drum, passes over a roller where the cake is discharged, and is washed before being directed back to the filter drum by another roller. These variations were developed to make the rotary filter more versatile--able to handle slurries forming gelatinous cakes that are difficult to discharge and, consequently, that foul the filter medium.

A third variation of the rotary drum filter uses a precoat, usually diatomaceous earth, that acts as the filter medium. As the drum rotates past a scraper, a thin portion of the precoat cake is removed along with the collected solids, resulting in a clean, unfouled surface each time a section of the drum enters the slurry. Precoat filtration provides excellent filtrate quality and can remove slimy solids that are difficult to filter and that would rapidly foul a permanent filter medium.

Precoat filtration is generally used to dewater dilute sludges because it offers a high filtration rate per unit of filter area. Precoat consumption usually ranges from 5 to 20 pounds for each 100 pounds of sludge solids (\$0.50-\$2/100 pounds of sludge solids) (Reference 13). The precoat does add to the quantity of solids for disposal, but often precoat filtration yields a cake with higher solids content than does standard vacuum filtration.

### c. Basket Centrifuges

Centrifuges dewater sludge in a manner similar to gravity thickening, but by rapidly rotating the sludge they create an apparent gravity thousands of times more powerful than normal. The centrifugal force thus created speeds up settling and magnifies the compaction effect, making centrifuges most suitable for compressive sludges that settle well. Several centrifuge types are available commercially, including basket, scroll, and disk centrifuges. Only the basket centrifuge is used to any degree to dewater plating sludge.

The basket centrifuge (Figure 26) is a vertical rotating bowl that has a lip extending inward at the top. Sludge is introduced into the bottom of the unit and the solids, owing to their greater density, are thrown against the inner wall of the basket. When the basket becomes full, clarified liquid (or centrate) is decanted over the inner lip and removed from the unit.

The rotating basket comprises two zones: against the outer wall of the basket is the solids retention zone, which contains the accumulated sludge solids; the rest of the basket constitutes the clarification zone, which separates the solids from the incoming feed. As the cycle continues, the volume of accumulated solids increases and reduces the capacity of the clarification zone until the residence time of the fresh feed in the clarification zone is insufficient to settle out the suspended solids. At this point, the level of solids in the centrate increases dramatically. This change, or "breakover," is detected by a monitor. The feed is cut off and a skimmer is run into the basket to remove excess water from the cake surface. The basket then decelerates from operating speed (anywhere from 1,000 to 3,000 rpm) to approximately 75 rpm. A plow enters the basket and pushes the cake out at the bottom of the centrifuge. As the plow retracts, the basket is accelerated and the feed is resumed.

The time required for the phases of the operating cycle when the unit is not receiving feed usually varies from 6 to 8 minutes. A unit of this type has a feed rate up to 60 gal/min, with solids recovery of 50 to 95 percent. It can produce a sludge cake ranging from 10 to 25 percent solids concentration.

#### d. Pressure Belt Filter

The pressure belt filter (Figure 27) is finding increased application because it offers certain advantages over other commonly used dewatering devices. This filter is especially suitable for dewatering the large, highly compressible particle floc characteristic of polymer-treated sludges. A common problem with such sludges is that, when subjected to a pressure gradient, the solid particles collapse against the filter medium and block the transport of water through the medium. The belt press eliminates this problem by using gravity to remove most of the water. Then, as the belt travels through successive regions, a gradual increase in pressure forces additional water from the sludge.

In the first stage of unit operation, the polymer-dosed sludge is spread over a slow-moving filter cloth belt and any free water drains off. To be suitable for further processing, the sludge should form a cohesive, continuous blanket in this region. The sludge blanket leaves the drainage section and enters the mild compression zone. Here, it is

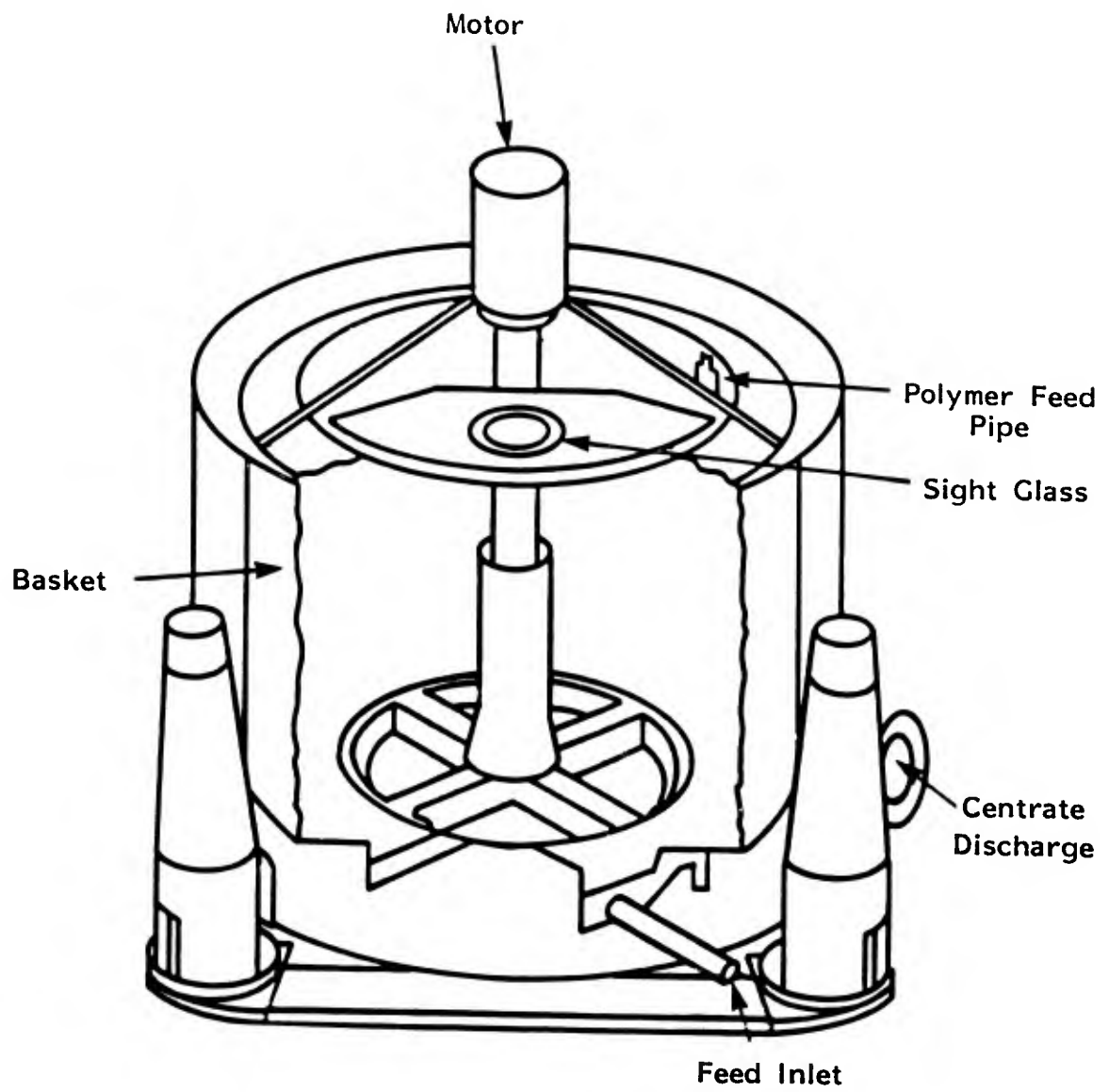

Figure 26. Basket Centrifuge

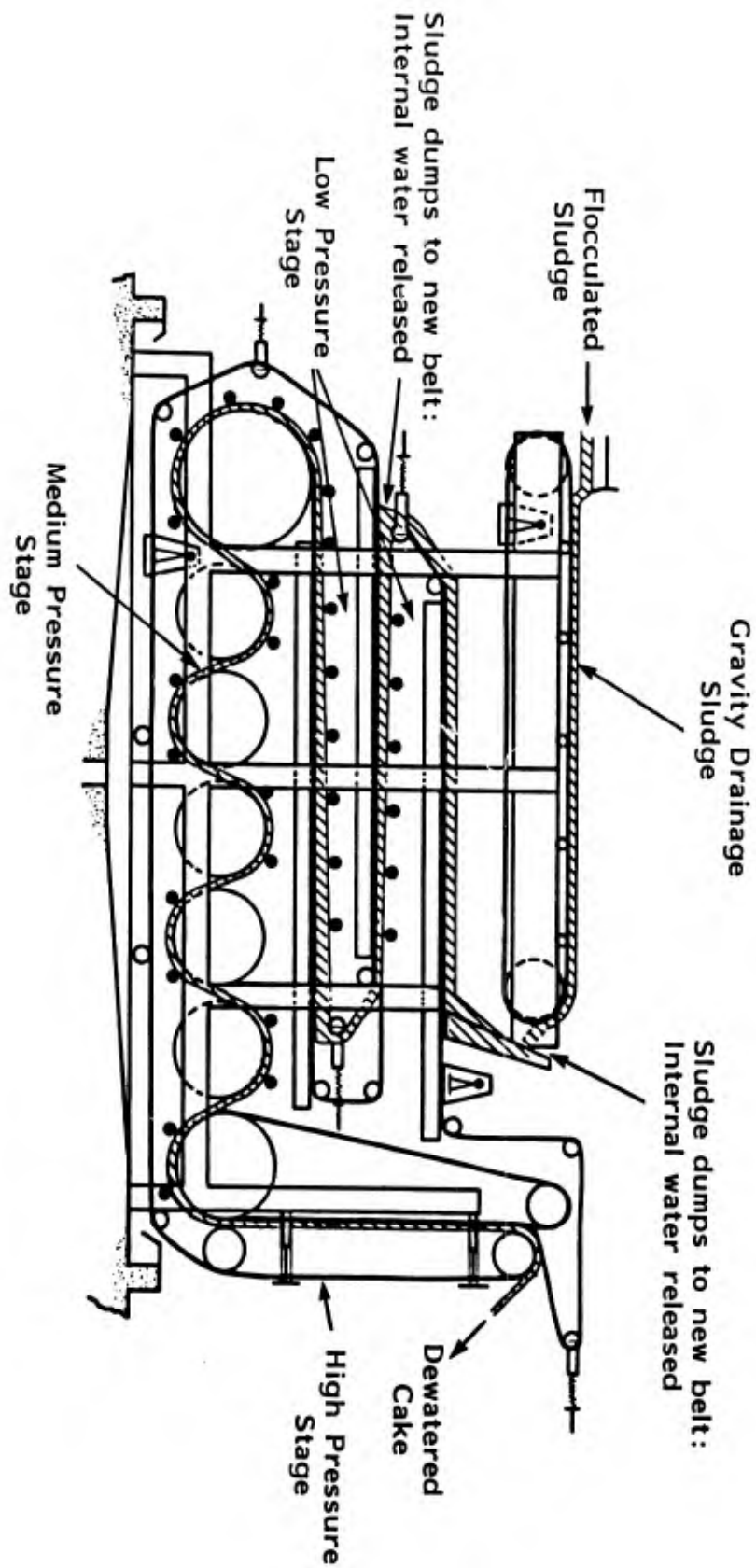

Figure 27. Pressure Belt Filter

compressed between water-permeable membranes, more water is forced out, and the sludge layer becomes a more nearly solid mass. The more cohesive the sludge layer becomes, the more compressive force it can absorb without extruding through the filter medium or being forced from between the belts. The compressive force gradually increases as the sludge layer travels through the unit--some models have compressive limits as high as 100 lb/in<sup>2</sup>. Sludge properties, cake thickness, time under compression, and the magnitude of the compressive force all influence the cake dryness.

The capacity of a belt press is determined by belt width and belt speed. Belt width depends on the model selected, and ranges from 1 to 10 feet. Belt speed sets the time the sludge will travel through the press. Unit capacity can be increased by adjusting the belt speed to compensate for a higher feed rate, but only to a limited degree. The major criterion for good filter operation is formation of a cohesive, solid sludge blanket in the gravity drainage zone. When feed rate increases, the belt speed will normally be lowered to allow additional drainage time; however, as with other filtration equipment, cake dryness will usually fall off as feed rate increases. For greater flexibility in meeting changing feed conditions, some units have separate filter belts and speed controls for the gravity dewatering and compression zones. This design also permits the use in each zone of a filter medium designed specifically for that zone.

### 3. Operation and Maintenance Requirements and System Performance

As with much mechanical equipment, there is a trade-off with dewatering equipment between operating labor requirements and mechanical sophistication. Of dewatering equipment types, filter presses are mechanically simple, with the feed pump often the only moving part. A filter press is a batch unit, however, and the filter cakes must be removed manually from each press chamber at the end of the cycle. Operation generally consists of low-skill duties. Filter presses are mechanically reliable owing to their operating simplicity.

Vacuum filters, centrifuges, and pressure belt filters are more automated and should require less operator labor, but they have more sophisticated maintenance requirements. Centrifuges, especially, have developed a poor reputation for dewatering sludge solids. The high rotation speed of the unit requires close tolerances and a degree of equipment care not common in waste treatment facilities. All three devices probably will require the attention of a skilled machanic to maintain reliable operation.

Table 16 compares some of the characteristics of the different equipment types. Table 17 summarizes the performance of different dewatering systems for metal finishing sludges in industrial applications.

TABLE 16. DEWATERING EQUIPMENT FOR ELECTROPLATING SLUDGE: TYPICAL PERFORMANCE CHARACTERISTICS

Equipment	Feed		Solids Retention (% by weight) <sup>a</sup>	Cake Solids Concentration (% by weight)	Installed Cost (\$1,000) <sup>b</sup>
	Rate (gal/min)	Solids (% by weight)			
Filter press	2-250	1-5	95-99	20-50	20-200
Vacuum filter	1-250	3-10	50-99	15-40	30-150
Precoat vacuum filter	1-250	0.5-3	95-99	20-50	30-150
Basket centrifuge	2-60	2-5	50-95	5-25	20-175
Pressure belt filter	5-200	2-6	90-95	20-40	40-200

<sup>a</sup>Feed solids in sludge cake.

<sup>b</sup>1981 dollars. Includes auxiliary equipment.

TABLE 17. PERFORMANCE OF DEWATERING EQUIPMENT FOR ELECTROPLATING SLUDGE

Equipment Type and Unit Size	Sludge Feed Rate (gal/h)	Solids (% by weight)		Comments
		Feed	Cake	
Recessed <sub>3</sub> plate filter press:				
8.5-ft <sup>3</sup> sludge-holding capacity	95	3	30	NA
10-ft <sup>3</sup> sludge-holding capacity	300	1-2	30	Plastic-plating lime sludge
12.5-ft <sup>3</sup> sludge-holding capacity	NA	NA	40	Chromium hydroxide dewatering
12-ft <sup>3</sup> sludge-holding capacity	825	5	35-40	Operating labor - 2-hour per shift; unit cleaned every 6-8 weeks
260-ft <sup>3</sup> sludge-holding capacity	12,000	3-6	30	with recirculated 50% HCL Heat-treated zinc hydroxide sludge
Vacuum filter <sup>a</sup>	NA	3-5	70-75	Metal oxide waste treatment sludge
Rotary precoat vacuum filter:				
9.4-ft <sup>2</sup> filtration area	100-150	NA	15	Low maintenance
37.7-ft <sup>2</sup> filtration area	330	1-5	30	Cloth life 1 year; repairs at \$200/year
Basket centrifuge:				
1-gal bowl capacity	120	3	12-20	Satisfactory performance: low maintenance
4-gal bowl capacity	120-150	5	18	High maintenance
Pressure belt filter: 9.8-ft-wide sludge-holding capacity	800	2-6	NA	Aluminum hydroxide sludge

<sup>a</sup>Unit size not available.

NOTE: NA = not available.

The data in Table 17 indicate that centrifugation will normally achieve solids concentration in the range of 12 to 20 percent by weight. Both precoat vacuum filtration and pressure filtration can achieve 30-percent cake solids by weight if the sludge has good filtration properties.

The one data point given for vacuum filtration (without precoat) shows that the equipment achieved 70- to 75-percent cake solids by weight. This high cake concentration resulted because the sludge was composed of metal oxides rather than metal hydroxides. The metal oxide precipitants can be dewatered to higher solids content than can hydroxides.

Only one data point is given for a belt filter press; this equipment has been used to a limited degree for metal finishing waste sludge. Its higher cost usually restricts its use to applications where other equipment types cannot provide satisfactory operation.

#### 4. Cost Factors

The cost of sludge disposal will depend primarily on volume. The volume of sludge can be reduced significantly by mechanical dewatering equipment.

Normally the clarifier underflow will contain between 0.5 and 3 percent solids by weight. Allowing the clarifier underflow to settle in a thickener tank will increase the solids content to between 2 and 5 percent by weight.

Vacuum filters, filter presses, pressure leaf filters, belt filters, and centrifuges have been applied successfully for mechanical dewatering of metal hydroxide sludges. The properties of individual sludges vary widely, however, and some pilot evaluations are necessary to determine whether a particular type of dewatering equipment is suitable. As a rule, equipment vendors will provide testing, if supplied with a sample of the sludge.

Four features are common to sludge dewatering systems (Figure 28):

- A solids collection sump
- One or more feed pumps
- Elevation of the dewatering device
- Filtrate return upstream

The solids collection sump receives the dilute clarifier underflow and provides a reservoir of feed solution so that the mechanical dewatering device can be fed continuously.

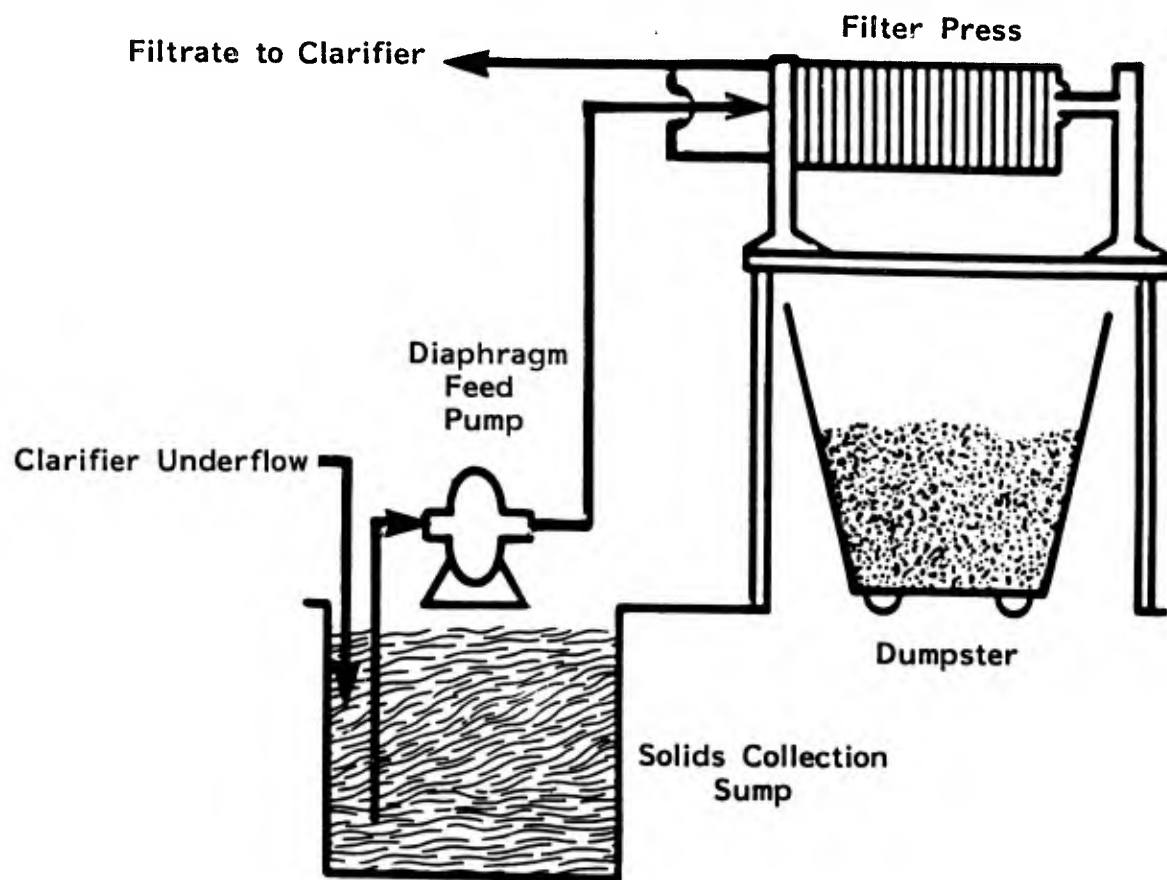

SOURCE: U.S. Environmental Protection Agency, Environmental Regulations and Technology: The Electroplating Industry, EPA 625/10-80-001, Aug. 1980

Figure 28. Recessed Plate Filter Press Unit and Auxiliaries Needed for Sludge Dewatering

The feed pump delivers the sludge to the dewatering device. Pump type depends on the physical properties and viscosity of the sludge, and on the type of dewatering device. Specially designed centrifugal, diaphragm, and progressive cavity pumps are suitable for handling slurries (Reference 5).

Elevating the dewatering device facilities handling dewatered sludge. Ideally, the dewatered sludge should be discharged directly into a hopper--the transport medium to the disposal site. If this approach is impractical, a straight run of conveyors can be used to transport the sludge to a point over the hopper.

Filtrate is returned to the clarifier or other upstream process vessel. Usually the level of suspended solids is too high to allow direct discharge.

Determining the capacity needed in the dewatering system requires testing. If a treatment system is already in place, capacity can be determined easily by measurement of the clarifier underflow volume and suspended solids concentration. Lacking a treatment system, a representative wastewater sample should be treated in a manner similar to that employed in the proposed treatment system. After treatment and settling, the volume of sludge generated per unit volume of water treated can be visually determined. A sample of the settled sludge can be analyzed for suspended solids content.

Vacuum filters, filter presses, centrifuges, and belt presses have all found application for dewatering sludge from metal finishing waste treatment. It is not usually necessary, however, to evaluate each alternative before selecting a dewatering system. Some general guidelines follow.

If disposal costs are less than \$15,000/year, it is unlikely that dewatering equipment would be justified economically. Many landfill sites can solidify or dewater dilute sludge, and their capabilities should be used.

The lowest cost alternatives in terms of capital investment are filter presses and small manual basket centrifuges. Minimum size versions of both systems can be installed for under \$30,000.

The small filter press system, although equal in cost to the centrifuge, will usually have more capacity. At low-feed rates, the cost per unit of capacity is lowest for the filter press. The low capacity per cycle of the basket centrifuge will require significant operating labor at flowrates above 10 to 15 gal, 1.

Poor-filtering sludges can usually be dewatered by precoat vacuum filtration. With polyelectrolyte conditioning, most sludges can be dewatered effectively with a centrifuge or belt filter.

Table 18 compares the investment and annual operating costs of the four equipment alternatives for flows ranging from 50 to 300 gal/h. At all levels, the filter press was least costly in general; however, at the higher range of flows the cost advantage was less significant.

In Table 19, the operating cost of disposing of 50 gal/h of clarifier underflow without dewatering is compared with the operating cost using dewatering equipment. In all cases, the investment in dewatering equipment had an excellent payback.

The filter press proves the best choice, mainly because of the low investment and manpower requirements. The 5-ft<sup>3</sup> cake volume of the press would only need dumping every 6 hours. A larger press could be selected to reduce labor, but the investment would be greater. Of course, if pilot testing indicated a sludge with poor filtration properties, either the properties would have to be modified or different equipment would have to be selected.

TABLE 18. COMPARATIVE TOTAL INVESTMENT AND ANNUAL OPERATING COSTS FOR SLUDGE DEWATERING

Feed Sludge Volume <sup>a</sup> (gal/h)	Costs (\$)							
	Filter Press		Precoat Rotary Vacuum Filter		Basket Centrifuge		Pressure Belt Filter	
	Installed Investment <sup>b</sup>	Annual <sup>c</sup>	Installed Investment <sup>b</sup>	Annual <sup>c</sup>	Installed Investment <sup>b</sup>	Annual <sup>c</sup>	Installed Investment <sup>b</sup>	Annual <sup>c</sup>
50	29,900	23,000	73,000	24,000	34,000	37,000	104,400	31,000
100	39,100	37,000	73,000	39,000	34,000	70,000	104,400	50,000
150	39,100	51,000	73,000	55,000	48,000	85,000	104,400	69,400
200	51,700	63,000	78,000	68,000	174,000	89,000	104,400	88,000
250	51,700	76,000	78,000	80,000	174,000	102,000	104,400	107,000
300	51,700	89,000	78,000	93,000	174,000	115,000	125,400	126,000

<sup>a</sup>Assumed at 3 percent solids by weight.

<sup>b</sup>Includes all system auxiliaries.

<sup>c</sup>Includes equipment operating, fixed, and sludge disposal costs.

NOTE: 1981 dollars.

TABLE 19. SLUDGE DISPOSAL UNDER FOUR DEWATERING ALTERNATIVES: ANALYSIS OF ANNUAL COSTS

Item	Present Conditions	With Installed Modifications			
		Filter Press <sup>a</sup>	Precoat Rotary Vacuum Filter <sup>b</sup>	Basket Centrifuge <sup>c</sup>	Pressure Belt Filter <sup>d</sup>
Disposal solids concentration (% by weight)	3	25	25	20	20
Cost of modifications (\$)	—	29,900	73,200	34,000	104,400
Annual cost of modifications (\$):					
Fixed	—	3,100	8,900	4,000	12,500
Operating	—	7,600	2,900	16,400 <sup>e</sup>	2,500
Annual sludge disposal cost (\$)	103,000	12,300	12,300	16,600	16,000
Total annual cost (\$)	103,000	23,000	24,100	37,000	31,000
Annual savings (\$)	—	80,000	78,900	60,200	68,200
Average return on investment (%) <sup>f</sup>	—	147	59	97	36
Investment payback (yr) <sup>g</sup>	—	0.6	1.5	0.9	2.2

<sup>a</sup>5-ft<sup>3</sup> filter capacity, 4-h cycle time.

<sup>b</sup>19-ft<sup>2</sup> filter area.

<sup>c</sup>Batch solid bowl centrifuge with 2-gal basket.

<sup>d</sup>1-ft-wide belt.

<sup>e</sup>Does not include cost of polymer treatment, which may be required.

<sup>f</sup>(Annual savings X 0.55)/total investment (0.55 based on a 45% tax rate).

<sup>g</sup>Total investment/(annual savings X 0.55 + depreciation.)

NOTE: 1981 dollars, 50 gal/h clarifier underflow.

## SECTION IV

### SUBSTITUTE TREATMENT TECHNOLOGIES

#### A. OVERVIEW

Substitute treatment technologies are processes that can be used in place of one or more of the conventional technologies. The development of substitute technologies has been prompted by a need to reduce the costs associated with waste treatment or to overcome the problems encountered in treating many waste streams in the conventional manner.

Conventional treatment presents a major problem that has been given repeated attention: the inability of the conventional precipitation process to reduce the solubility of dissolved metals to levels required for discharge of the waste stream. Two frequent situations have occurred. First, some local jurisdictions have adopted discharge standards much more stringent than the Federal regulations. Because the Federal regulations are based on the technical capabilities of conventional treatment, these processes are unable to achieve the lower concentration limits. Second, plating wastewaters often contain compounds that interact with dissolved metals and interfere with their precipitation as metal hydroxides. Such compounds as ammonia, phosphates, tartrates, and ethylenediaminetetraacetic acid (EDTA) are commonly used in plating operations and consequently find their way into the wastewater. These compounds, called chelates, combine with the dissolved metal ion to form a complexed ion that is relatively soluble in neutral or slightly alkaline solutions. In many cases, waste streams containing chelates cannot be treated with conventional precipitation to the level required by Federal regulations.

The generation of large volumes of sludge has also been cited as a problem with conventional treatment. Metal finishing sludges have been classified as hazardous by EPA. Disposal areas for hazardous wastes are unavailable in many parts of the country and waste generators may be forced to transport hazardous wastes long distances. The transportation costs combined with high disposal fees have made sludge disposal a significant part of the overall treatment costs.

A frequent problem in wastewater treatment is that, in some cases metal discharge requirements are not being met, even though the level of dissolved metals in the effluent is low. In cases of this kind, the solids separation component of the process is allowing too much suspended matter, including precipitated metals, to pass into the discharge. This condition can

result from overloaded clarifiers, ineffective conditioning (coagulation or flocculation) of the clarifier feed, or poor pH control.

A further problem in conventional treatment has been the alkaline chlorination process for cyanide destruction. The treatment reagents used in this process are either sodium hypochlorite or chlorine gas plus sodium hydroxide. Chlorine gas, which is stored in pressurized cylinders, presents a safety problem. Both sodium hypochlorite and chlorine gas are expensive and usually contribute significantly to treatment costs.

The alkaline chlorination process cannot oxidize stable cyanide complexes such as ferrocyanides. Therefore, some treatment systems that use this process are unable to meet discharge standards. Also, when chlorine is used, an occasional problem is the formation of toxic chlorinated organic compounds.

The substitute technologies discussed in this section offer solutions to the technical problems encountered with conventional treatment or, in some cases, offer cost savings through a reduction in equipment requirements or operating expenses such as chemical reagent purchases. In all cases, however, substitute technologies offer a trade-off. Their advantages are gained at the expense of other benefits. Such trade-offs are often site-specific and must be evaluated case by case.

The following substitute technologies have been included in this report:

- Sulfide precipitation
- Ion exchange
- Sodium borohydride
- Ozone oxidation
- Thermal oxidation
- Freeze crystallization
- Insoluble starch xanthate
- Sacrificial iron anodes
- Ultrafiltration and microfiltration
- Ferrous sulfate reduction
- Integrated treatment

Sulfide precipitation, which precipitates metals as sulfides instead of hydroxides, has been found capable of achieving low levels of metal solubility in highly chelated

waste streams. The process has been proven as an alternative to hydroxide precipitation or as a method for further reducing the dissolved metal concentration in the effluent from a hydroxide precipitation system. Two processes are used for sulfide precipitation: the soluble sulfide process uses sodium sulfide as the treatment reagent, and the insoluble sulfide process uses ferrous sulfide. Both processes generate metal sulfide sludge and the sludge may be more difficult to dispose of safely because of the sulfide's potential reactivity. In addition, a drawback of the insoluble sulfide precipitation process is that it generates a significantly larger volume of sludge compared with conventional treatment. The large sludge volume is caused by the liberation of ferrous ions from the treatment reagent; these ions are converted to ferrous hydroxide and add to the sludge volume.

Insoluble starch xanthate (ISX) precipitation can remove heavy metal cations from wastewaters. The ISX acts as an ion exchange material that removes heavy metal ions and replaces them with sodium or magnesium ions. Currently, it is applied as an alternative to hydroxide precipitation or to "polish" treated wastewater to lower the residual metal concentration. Because it is insoluble in water and its precipitation reaction rate is rapid, ISX is used either as a slurry with the stream to be treated or as a precoat on a filter.

Sodium borohydride precipitation can also be substituted for hydroxide precipitation to achieve lower effluent concentrations. Sodium borohydride is a strong reducing agent, capable of precipitating many heavy metals in their elemental form. Compared with conventional treatment, this process offers the additional advantage of producing a low volume of sludge. A drawback is the high cost of the sodium borohydride reagent.

Ion exchange, using resins that have a strong selectivity for heavy metal ions (rather than for the calcium and sodium ions normally present in the wastewater), has been proven effective in lowering the metal concentration in the wastewater discharge. Heavy metal selective resins have been used both as stand-alone treatment systems and as a means of polishing wastewater after conventional treatment. Ion exchange has proved to be one of the few treatment processes capable of removing copper and nickel from the highly complexed wastewater associated with electroless plating.

Ozone oxidation of cyanides has been practiced as a substitute technology for alkaline chlorination. It is effective in destroying cyanide to the levels required by EPA. The advantage of using ozone lies in reduced operating costs. Ozone is generated onsite and is less expensive than chlorine or sodium hypochlorite. The equipment cost is significantly higher, however, owing to the expense of an ozone generator. In addition to cost, a further advantage of ozone oxidation is the absence of chlorine that can combine with organics present in the wastewater to produce toxic compounds.

Thermal oxidation is another substitute technology for alkaline chlorination. The process involves the use of a heated reactor where cyanides are destroyed without the addition of chemicals. The process is energy-intensive; however, it can be cost effective for concentrated cyanide solutions such as spent baths, cleaners, strippers, or concentrated rinse water.

Freeze crystallization is a substitute technology for conventional treatment that has not progressed past the development stages. The process separates water from contaminants by forming water ice crystals. The process is energy intensive and is not applicable to the large waste volumes encountered at most plating facilities.

Sacrificial iron anodes are a substitute technology for the conventional sulfur compound chromium reduction process. This technology makes use of an electrochemical reaction in which an electrical current is applied to consumable iron electrodes. The process has the advantage of being able to reduce chromes at neutral pH. A drawback is that the process produces ferric hydroxides, which increase the quantity of sludge.

Ultrafiltration and microfiltration are substitute technologies for conventional clarification. These technologies use a porous structure to filter particulates from a liquid phase. Previous applications were limited to effluent polishing, following conventional clarification. New advances in design, however, allow for direct filtering of flocculated wastewater. The advantages of ultrafiltration and microfiltration and that the solids content of the effluent is lower than with conventional clarification. These units are more expensive than clarifiers, posing an economic disadvantage.

Ferrous sulfate reduction has been used to reduce chromate in an acid environment for a number of years. The primary advantage for many facilities was an inexpensive, abundant supply of ferrous sulfate, which is a waste product from steel pickling. The disadvantage of the process is the considerable increase in sludge generation owing to the precipitation of ferric hydroxide in the neutralization phase of the treatment. Recently, pilot evaluations of alkaline ferrous sulfate reduction of chromate have shown promising results. The process still has unfavorable sludge generation characteristics, but the reduction can be accomplished in the same reaction vessel as neutralization.

Integrated treatment means integrating the treatment process into the plating operation. The rinse tank following a plating bath contains treatment chemicals instead of water; the plated parts are rinsed in the chemical solutions and the pollutant carryover is neutralized. Integrated treatment is used primarily for cyanide and chromate plating and can eliminate the need to install conventional treatment processes for these pollutants.

## B. SULFIDE PRECIPITATION

### 1. Summary and State of Technology Development

Sulfide precipitation of heavy metals has been commercially demonstrated using two distinctly different processes. The main difference is in the reagent used to supply the sulfide ion. Soluble sulfide precipitation uses a water-soluble sulfide reagent such as sodium sulfide ( $\text{Na}_2\text{S}$ ) or sodium hydrosulfide ( $\text{NaHS}$ ). A more recently developed process adds a slightly soluble ferrous sulfide ( $\text{FeS}$ ) slurry to supply the sulfide ions needed to precipitate the heavy metals. The advantages of both sulfide processes include the high reactivity of the sulfide ions with heavy metal ions, the insolubility of heavy metal sulfides over broad pH ranges, and the lower solubility of metal sulfides compared with metal hydroxides. Sulfide precipitation can also achieve low metal solubilities in the presence of certain metal complexing agents (Reference 14).

The soluble sulfide process, although long recognized as a metal removal method, had minimal application for wastewater treatment owing to operational difficulties. Technological advances have resolved many of these. Recent developments in specific ion electrodes have provided a probe for controlling the addition of sulfide reagent to match demand. Formulation of polyelectrolyte conditioners that effectively flocculate the fine metal sulfide particles has eliminated the difficulty in separating the precipitants from the discharge.

The insoluble sulfide process was developed and patented by the Permutit Company under the trade name Sulfex® in the late 1970s. An early demonstration of the process, partially funded by EPA, was at Holly Carburetor in Paris, Tennessee. A number of systems were installed in plating facilities, and the systems proved reliable in achieving lower concentrations of dissolved metals in wastewater effluent than those achieved by conventional hydroxide precipitation systems. The insoluble sulfide process also is advantageous in that it will reduce hexavalent chromium and precipitate chromium hydroxide, eliminating the need for a separate chromium reduction unit. Further, the process can precipitate metals to low levels in the presence of complexing compounds (Reference 14). These advantages led to the belief that the process would supplant the use of hydroxide precipitation in many facilities.

Despite advantages compared with hydroxide precipitation, neither sulfide process has gained significant commercial success because of the concerns about residual (sludge) disposal that came about as a result of the RCRA legislation. The sulfide process generates a metal sulfide sludge that, according to RCRA, might be classified as reactive in addition

to toxic. The potential sludge disposal problem has virtually eliminated any demand for the processes, even though they were shown to be effective in removing metals from plating waste streams.

The Sulfex® system relies on a ferrous sulfide slurry to provide the source of the sulfide ions; consequently, the iron associated with the sulfide precipitates as the hydroxide and adds considerably to the sludge volume. The process requires greater than stoichiometric amounts of ferrous sulfide, which also adds to the sludge volume. Consequently, the process generates considerably more sludge than conventional treatment (Reference 14). The current high cost of sludge disposal makes this disadvantage significant.

## 2. Process Description

### a. Insoluble Sulfide

The insoluble sulfide process has the same basic components as a hydroxide precipitation system except that a mixer/clarifier is necessary to mix the wastewater and the ferrous sulfide slurry. Figure 29 shows components and process flow of a commercial system.

The key elements of the system are:

- pH control
- Mixer/clarifier
- Reagent addition to mixer/clarifier
- FeS feed rate control
- Sand filter

For effective metal removal by sulfide or hydroxide precipitation, the pH of the wastewater must be controlled within the neutral to slightly alkaline range. Although the dependence of metal solubility on pH is not critical for sulfide precipitation systems, it still affects metal removal. Control of pH is needed to eliminate the danger of the FeS slurry coming into contact with acidic wastewater; FeS is soluble in acidic solutions, and mixing it with low pH wastewater would result in the emission of toxic H<sub>2</sub>S fumes in the work area.

The mixer/clarifier provides contact between the wastewater and the FeS slurry--the solid-liquid contact is necessary to maintain the wastewater sulfide ion concentration at its saturation point. It also clarifies the effluent of suspended solids.

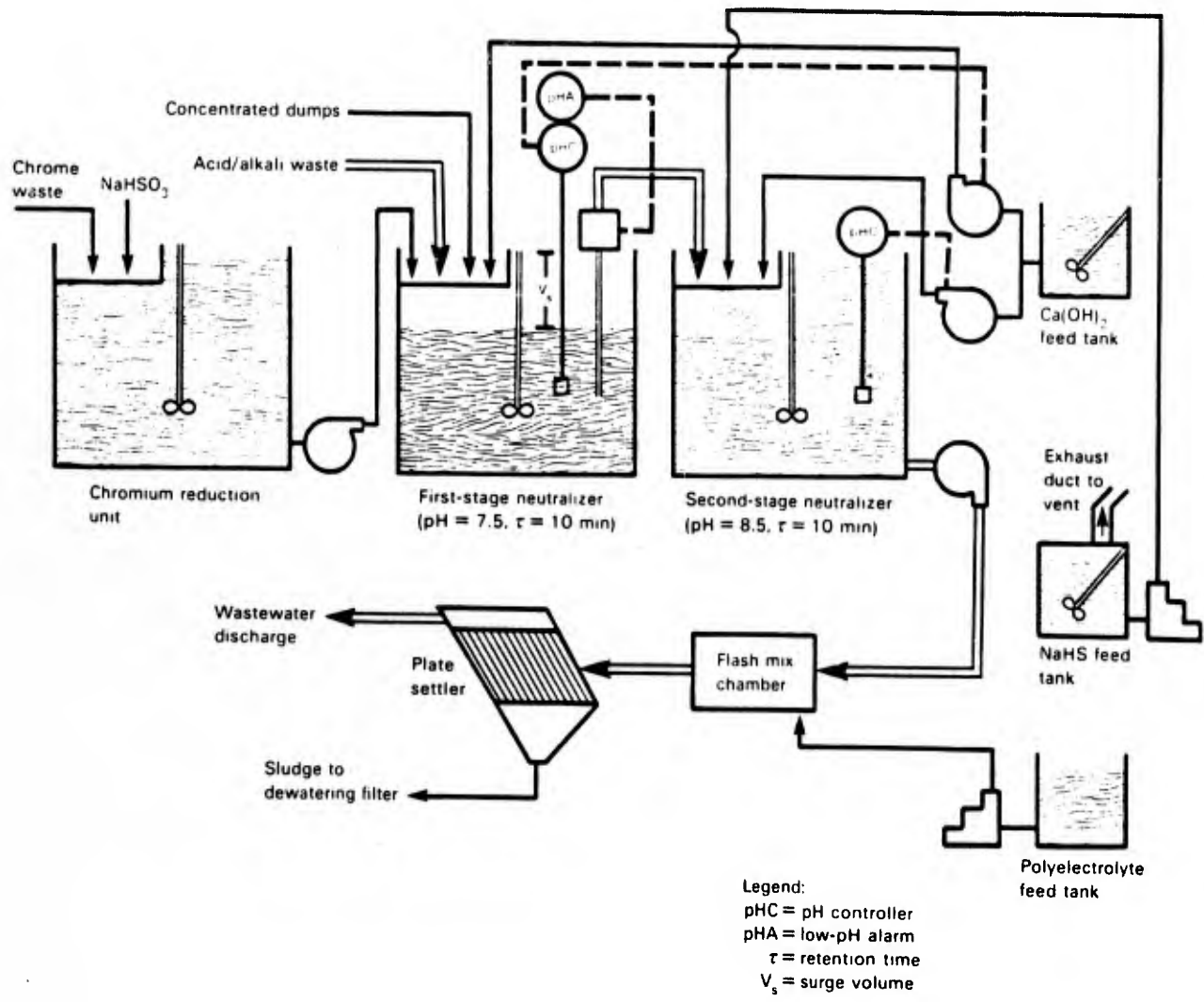

Figure 29. Soluble Sulfide Treatment System

Reagent addition to the mixer/clarifier is controlled by a flow-measuring device that monitors the feed to the mixer/clarifier and sends a signal to a counter, which computes the cumulative flow. The additions of fresh FeS and polymer are controlled to provide a set quantity of each when the counter records a set volume going through the system. The dosage rate is determined for both reagents through a series of jar tests.

The amount of reagent added is set manually, based on the results of the jar tests. The inability to adjust the FeS reagent dosage automatically in response to changes in reagent demand complicates operation of insoluble sulfide treatment systems. To compensate for the lack of automatic control, two features must be considered in design of the system:

- FeS reagent demand averaging
- Maintaining an inventory of unreacted FeS in the mixer/clarifier

Reagent demand averaging requires the elimination of sharp deviations in wastewater flow rate and pollutant concentration entering the treatment system.

There should be unreacted FeS in the mixer/clarifier to provide sulfide reagent when reagent demand exceeds supply. Because demand fluctuations are inevitable, an inventory of reagent is essential for consistent maximum removal of metals. FeS is stored in the mixer/clarifier in a quantity proportional to the quantity of solids maintained in the unit, and to the concentration of FeS in those solids.

A sand filter is included in the system to ensure a minimum concentration of suspended solids in the wastewater discharge. To meet strict metal discharge requirements, the level of all metals, dissolved and insoluble, in the effluent discharge must be reduced to a minimum. For both sulfide and hydroxide precipitation systems, a sand filter ensures that upsets in the treatment system causing turbidity in the clarifier overflow will not jeopardize effluent quality.

#### b. Soluble Sulfide

The soluble sulfide process is identical to conventional hydroxide neutralization/clarification, except that a sodium sulfide solution is added to the wastewater in the neutralizer. Figure 30 shows a commercial treatment process that uses lime and sodium sulfide.

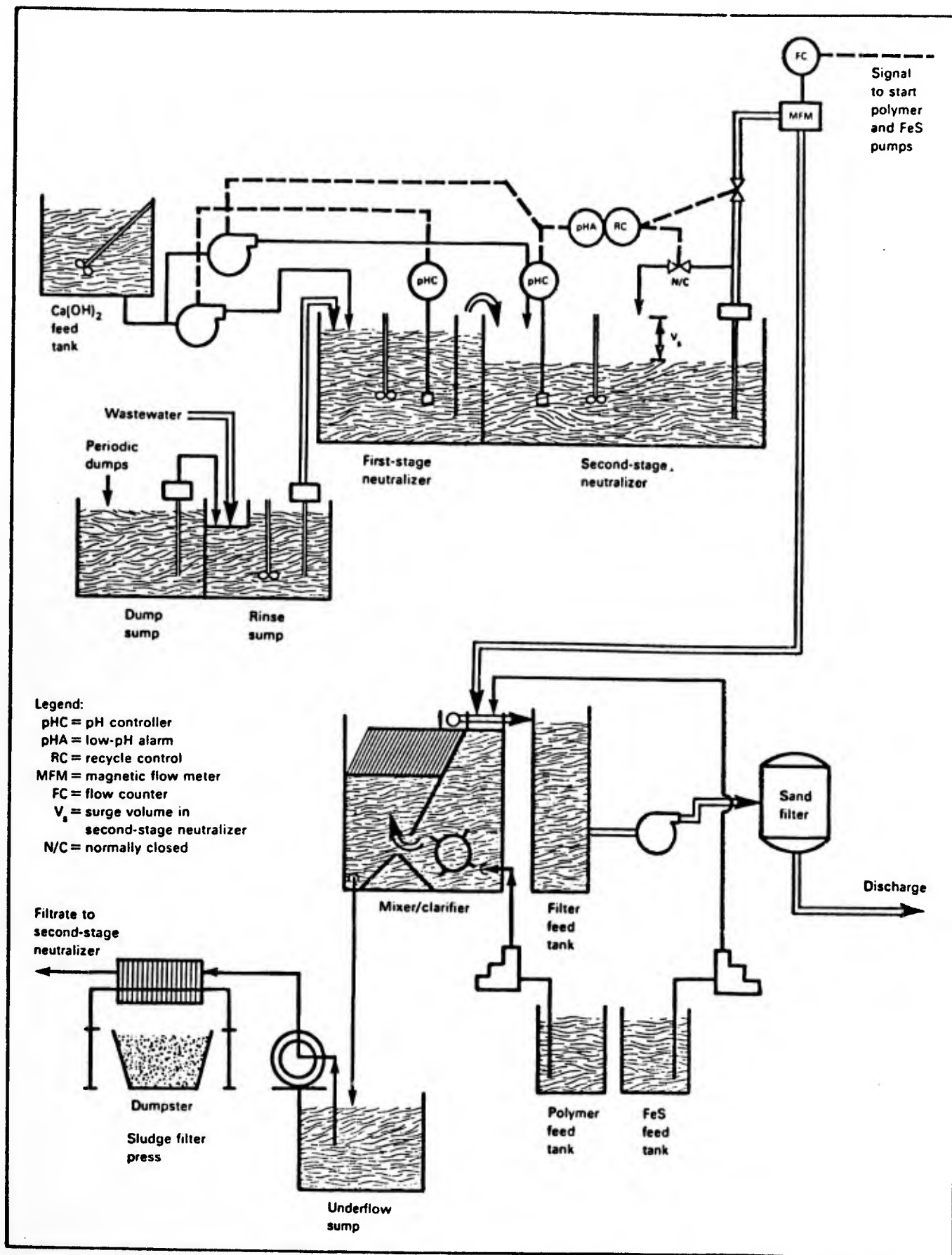

Figure 30. Insoluble Sulfide Treatment Process Components

The system shown in Figure 30 sets the sulfide reagent addition at a constant rate to provide an excess over the average reagent demand determined by testing. As there is no direct control of reagent addition, there is generally a residual of sulfide in the wastewater. Because of this residual concentration, all treatment tanks have had to be covered and ventilated to avoid odor problems in the work area.

Recent development of a sulfide-specific ion probe should provide a means of controlling the residual sulfide level below 1 ppm and eliminate the need to cover treatment tanks. The probe has been used successfully in pilot evaluations, but not in the rigorous demands of a commercial treatment system.

### 3. Operation and Maintenance Requirements and System Performance

For both sulfide treatment processes, as with conventional hydroxide treatment systems, routine operational requirements focus on maintaining reagent supply, calibrating instrumentation, operation of sludge dewatering filter, sample collection, and periodic back-flushing of the sandfilter. Sulfide systems currently in commercial use are reasonably new and, therefore, have the necessary sensors and instrumentation to notify the operator if any action is required.

With the insoluble sulfide process, jar tests must be conducted to determine ferrous sulfide reagent requirement and the sludge blanket density must be monitored.

Jar tests are conducted on approximately four samples to determine the lowest FeS dosage that will provide optimum metal removal. Because polyelectrolyte should be added in proportion to the demand for FeS, it is fed at a constant rate in that proportion. Jar tests normally are conducted once or twice per shift to determine the proper addition rate.

Based on the jar test results, the control for FeS and polymer addition is set to feed the needed quantity of reagents each time a set feed increment has entered the mixer/clarifier.

The level of solids in the mixer/clarifier is monitored periodically (normally every 1 to 2 hours) through a settling test performed on samples removed from the mixing zone of the mixer/clarifier. The sludge blow-down rate is adjusted to maintain the maximum solids concentration compatible with low levels of turbidity in the clarified effluent.

The system shown in Figure 29 needed a full-time operator during one shift, and approximately 2 to 4 hours of operator attention during other shifts. The staffing requirements for a sulfide precipitation system are approximately equal to conventional hydroxide treatment systems; however, the

operator must perform testing that demands a skill more sophisticated than that associated with operating a hydroxide system. Consequently, more operator training is necessary.

The performance of the insoluble sulfide treatment systems for removing metals and reducing chromates has proven superior to that of hydroxide treatment systems. Table 20 gives the raw and treated wastewater analysis for a plant using the system.

Tables 21 and 22 give performance data for soluble sulfide precipitation at two commercial facilities. Both applications were to wastewater containing metal complexing agents. In Table 21, the hydroxide solubilities of cadmium, zinc, and mercury are shown, along with the effect of increasing sulfide additions. For this dilute waste stream, 5 to 10 mg/l of sulfide provided the optimum treatment.

#### 5. Residuals Generated

A major drawback of sulfide precipitation processes is that they generate a sludge that is a mixture of metal hydroxides and metal sulfides. The concern over disposal of metal sulfide sludge lies in the hazard that could result if the sludge is exposed to an acidic environment. The sludge would then react to release toxic hydrogen sulfide fumes. This concern could make disposal of the residual more difficult and costly. As a further drawback, the insoluble process generates significantly larger volume of sludge than conventional processes.

#### 6. Cost Factors

The costs of soluble sulfide treatment systems are comparable to those of equivalent hydroxide systems. The additional cost for a sulfide specific ion probe and a ventilated reagent feed tank and pump should be between \$6,000 to \$10,000. The reagent cost for 1,000 gallons of wastewater treated by sodium sulfide should range from \$0.20 for wastewater containing 50 ppm heavy metals to \$0.40 for wastewater containing 100 ppm of heavy metals. Cost for neutralization and flocculation chemicals should be equal to a hydroxide system.

Investment cost for an insoluble sulfide treatment system relates primarily to the volumetric flow rate of wastewater that must be processed. Table 23 gives the cost of three systems with flow rates ranging from 15 to 40 gal/min, excluding any cost for building space and collection of waste streams. The cost is essentially for the components shown in Figure 29.

Operating costs are a function of wastewater flow rate and pollutant concentration. Table 24 gives the individual operating costs for the same three plants. Chemical costs ranged from \$1.77 to \$2.58 per 1,000 gallons of wastewater

TABLE 20. POLLUTANT REMOVAL BY INSOLUBLE SULFIDE  
PRECIPITATION TREATMENT SYSTEM

Item	Wastewater Analysis		
	Influent	Effluent	Permit Requirements <sup>a</sup>
pH	2.9	8.5	6.0-9.5
Phosphorus (mg/l)	289	0.3	<1.2
Total suspended solids (mg/l)	320	6	<23
Total chromium (mg/l)	8	<0.10	<0.6
Hexavalent chromium (mg/l)	0.07	<0.02	<0.06
Nickel (mg/l)	0.77	<0.1	<0.6
Zinc (mg/l)	24	0.12	<0.6
Iron (mg/l)	127	0.60	<1.2

<sup>a</sup>Monthly average of daily composite samples.

TABLE 21. SULFIDE PRECIPITATION OF CADMIUM, ZINC, AND MERCURY

Metal (mg/l)	Raw Waste	Hydroxide Solubility at pH of 8.5	Supernatant <sup>a</sup>		
			Sulfide Addition (mg/l)		
			1	5	10
Cadmium	2.1	2.0	1.6	0.39	0.06
Zinc	3.0	2.25	1.8	1.5	1.1
Mercury	0.006	0.0027	0.0013	0.001	0.0008

<sup>a</sup>Polyelectrolyte dose = 1 mg/l; settling time of 2 hours.

NOTE: Stoichiometric sulfide requirement to precipitate mixture given is 2.1 mg/l of sulfide based on raw waste composition.

TABLE 22. REMOVAL OF COMPLEXED COPPER AND OTHER METALS FROM ELECTROPLATING WASTEWATER

Metal (mg/l)	Untreated Wastewater	Filtrate
Copper	17	0.4
Nickel	0.3	<0.2
Lead	1.85	<0.2
Zinc	0.86	0.4
Tin	4.29	<1.0

NOTE: Batch treatment sequence: lime added to pH of 11; NaHS added to equivalent sulfide ion concentration of 20 mg/l (stoichiometric requirement = 10 mg/l); filtered through diatomaceous earth filter; final pH adjustment to 8 before discharge.

TABLE 23. INSTALLED COST OF INSOLUBLE SULFIDE  
PRECIPITATION TREATMENT SYSTEMS

Cost component	ISP system cost (\$1,000)		
	Plant A	Plant B	Plant C
Installation costs:			
Process equipment	175	92	NA
Underground tanks	36	48	NA
Shipping and installation	29	22	NA
Additional building space	20	NA	NA
Startup expenses	3	NA	NA
Engineering	NA	17	NA
Other	NA	1	NA
Total	263 <sup>a</sup>	180 <sup>b</sup>	155 <sup>c</sup>
Current installation costs <sup>d</sup>	303	195	169

<sup>a</sup>ISP system design flow = 40 gal/min; installed in September 1977.

<sup>b</sup>ISP polishing system design flow = 35 gal/min; installed in April 1978.

<sup>c</sup>ISP polishing system design flow = 15 gal/min; installed in March 1978.

<sup>d</sup>Costs escalated to March 1979 based on Chemical Engineering Plant Cost Index.

NOTE: NA = not available.

TABLE 24. WASTEWATER CHARACTERISTICS AND TREATMENT PROCESS PARAMETERS FOR INSOLUBLE SULFIDE SYSTEMS

Characteristic	Value		
	Plant A	Plant B	Plant C
<b>Wastewater:</b>			
Average flow rate (gal/min)	39	21	16
<b>pH:</b>			
Feed	2.0-4.0	4.5-6.0	2.5-3.0
Effluent	9.0-10.0	8.5-9.5	7.5-8.5
<b>Average feed concentration (ppm):</b>			
Nickel	31	NA	NA
Copper	28	NA	NA
Hexavalent chromium	76	27	0.07
Total chromium	88	39	8
Zinc	NA	48	24
Iron	NA	1.4	127
Phosphorus	NA	NA	289
<b>Treatment chemicals:</b>			
<b>Lime:<sup>b</sup></b>			
lb/h	8.8	2.0	8.1
\$/h	0.28	0.06	0.60
<b>Calcium chloride (for phosphate removal):<sup>b</sup></b>			
lb/h	NA	NA	17.0
\$/h	NA	NA	1.70
<b>Cationic polymer:<sup>b</sup></b>			
lb/h	0.1	0.17	0.02
\$/h	0.14	0.23	0.04
<b>Anionic polymer:<sup>b</sup></b>			
lb/h	NA	NA	0.01
\$/h	NA	NA	0.03
<b>Ferrous sulfide:</b>			
lb/h	12.5 <sup>c</sup>	4.5 <sup>d</sup>	0.30 <sup>b</sup>
\$/h	5.37 <sup>c</sup>	1.94 <sup>d</sup>	0.11 <sup>b</sup>

TABLE 24. WASTEWATER CHARACTERISTICS AND TREATMENT PROCESS PARAMETERS FOR INSOLUBLE SULFIDE SYSTEMS (Continued)

Characteristic	Value		
	Plant A	Plant B	Plant C
Total chemicals (\$/h)	5.78	2.23	2.48
Chemical cost (\$/1,000 gal)	2.47	1.77	2.58 <sup>e</sup>
Sludge generation factors:			
Dry solids generation:			
lb/h	23.7	7.2	16.4
First stage	NA	NA	16
Second stage	NA	NA	0.4
lb/1,000 gal wastewater	10.1	5.7	17 <sup>e</sup>
Underflow volume			
(gal/h at 0.75% solids)	380	114	262
Filter cake volume			
(gal/h at 30% solids)	7.9	2.4	5.3

<sup>a</sup>All three plants use an ISP process to remove metals from wastewater, but Plant C uses ISP as a polishing system.

<sup>b</sup>Observed rates.

<sup>c</sup>Based on 3 times the stoichiometric requirement.

<sup>d</sup>Based on 4 times the stoichiometric requirement.

<sup>e</sup>Without the presence of phosphates, treatment cost equals \$0.81/1,000 gal, solids generation equals 6.4 lb/1,000 gal.

NOTE: 1979 cost basis, NA = not applicable.

treated. Sludge disposal cost varies considerably, depending on distance to site, volume of sludge generated, and disposal method; this cost was not available. Using a base disposal cost of \$0.50 per gallon, the cost of sludge disposal ranged from \$0.95 per 1,000 gallons of wastewater for Plant B to \$2.76 per 1,000 gallons for Plant C. The high cost for Plant C stemmed primarily from the high phosphate content of the wastewater and did not result from insoluble sulfide treatment.

Operating cost for staffing and electricity would be in addition to the costs in Table 24.

### C. ION EXCHANGE

#### 1. Summary and State of Technology Development

Ion exchange is a versatile separation process with potential for broad application in the metal finishing industry. The ion exchange process has been commercially available for many years, but has been used primarily for water deionization or softening. Widespread interest in the process for metal finishing pollution control and water or raw material recovery has developed only recently. The main impetus for this application of ion exchange is the broad range of resins currently available. With proper resin selection, ion exchange can provide an effective, economical means of meeting water pollution control requirements.

Specific applications of ion exchange in the metal finishing industry include (Reference 15):

- Wastewater purification and recycle
- "Polishing" of treated wastewater for further reduction in the level of heavy metal pollutants
- Removal of metal pollutants from wastewater before discharge
- Chromic acid recovery from rinse water
- Nickel salt recovery from rinse water
- Removal of cationic impurities from chromic acid process baths
- Purification of acid solutions to remove metal ions

Each of these applications has proved reliable in commercial applications. Depending on the specific application, however, the need for pretreatment of the wastewater prior to the ion exchange system should be evaluated. Pretreatment requirements and choice of a suitable resin can dramatically effect the system performance.

Ion exchange materials either exist naturally as inorganic zeolites, or are synthetically produced organic resins. The synthetic resins are the predominant type used today because their characteristics can be tailored to specific applications. The resins are broadly classified as cation exchangers, which exchange positively charged ions (for example,  $\text{Ni}^{+2}$ ,  $\text{Na}^{+}$ ), or anion exchangers, which exchange negatively charged ions (for example,  $\text{SO}_4^{-2}$ ,  $\text{OH}^{-}$ ). Within both groups there are strongly and weakly ionized resins that describe the bond strength between the exchangeable ion and the organic radical to which it is attached.

Recently, a new breed of resins has been made available commercially. These resins are distinctive in having a strong preference, or selectivity, for specific ions over other ions of similar charge. The ion selective resins, often called chelate resins, can be used to separate and concentrate a specific ion (for example,  $\text{UO}_2(\text{SO}_3)_2^{-4}$ ,  $\text{Cu}^{2+}$ ) from a solution containing high levels of other dissolved compounds (Reference 15).

Another recent development is the use of liquid ion exchange solvents. In this process, the exchangeable ion is attached to an organic radical in solution. The process has many potential advantages over conventional resin techniques, but because of the current state of development, liquid ion exchange will not be covered in this report.

## 2. Process Description

### a. Basic Concepts

Ion exchange is a reversible chemical reaction wherein an ion (an atom or molecule that has lost or gained an electron and thus acquired an electrical charge) from solution is exchanged for a similarly charged ion attached to an immobile solid particle.

An organic ion exchange resin is composed of high-molecular-weight polyelectrolytes that can exchange their mobile ions for ions of similar charge from the surrounding medium. Each resin has a distinct number of mobile ion sites that set the maximum quantity of exchanges per unit of resin.

Ion exchange reactions are stoichiometric and reversible, and in that way they are similar to other solution phase reactions. A resin with hydrogen ions available for exchange will exchange those ions for nickel ions from solution. The reaction can be written as follows:

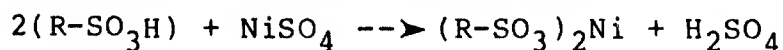

R indicates the organic portion of the resin and  $\text{SO}_3$  is the immobile portion of the ion active group. Two resin sites are needed for nickel ions with a plus 2 valence ( $\text{Ni}^{+2}$ ). Trivalent ferric ( $\text{Fe}^{+3}$ ) ions would require three resin sites.

The resin can be converted back to the hydrogen form by contact with a concentrated acid solution:

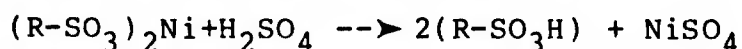

This step is known as regeneration. Ion exchange resins are classified as cation exchangers, which have positively charged mobile ions available for exchange, and anion exchangers, whose exchangeable ions are negatively charged. Both anion and cation resins are produced from the same basic organic polymers. They differ in the ionizable group attached to the hydrocarbon network. It is this functional group that determines the chemical behavior of the resin. Resins can be broadly classified as strong or weak acid cation exchangers or strong or weak base anion exchangers.

Strong acid resins are so named because their chemical behavior is similar to that of a strong acid. The resins are highly ionized in both the acid ( $\text{R-SO}_3\text{H}$ ) and salt ( $\text{R-SO}_3\text{Na}$ ) form. In a weak acid resin, the ionizable group is a carboxylic acid ( $\text{COOH}$ ) rather than the sulfonic acid group ( $\text{SO}_3\text{H}$ ) used in strong acid resins. These resins behave similarly to weak organic acids that are weakly dissociated. Because weak acid resins have an affinity for hydrogen ions, they have a limited exchange capacity when used to treat solutions with a pH below 6.0.

Like strong acid resins, strong base resins are highly ionized and can be used over the entire pH range. Weak base resins are like weak acid resins, in that the degree of ionization is strongly influenced by pH. Consequently, weak base resins exhibit minimum exchange capacity above a pH of 7.0.

A major advantage of both weak acid and weak base resins is that they can be regenerated much more efficiently than the strong acid and strong base resins. Weakly ionized resins can be regenerated with slightly greater than the stoichiometric reagent requirement.

Many specialty resins are now in commercial use. A chelating resin that exhibits a high selectivity for metal cations over other cations in solution has been used in metal finishing.

Chelating resins are analogous to chelating compounds found in metal finishing wastewater; that is, they tend to form stable complexes with the heavy metals. In fact, the functional group used in these resins is an EDTA compound.

Most industrial applications of ion exchange used fixed-bed column systems, the basic component of which is the resin column (Figure 31). The column must:

- Contain and support the ion exchange resin
- Uniformly distribute the service and regeneration flow through the resin bed
- Provide space to fluidize the resin during backwash
- Include the piping, valves, and instruments needed to regulate flow of feed, regenerant, and backwash solutions

After the feed solution is processed to the extent that the resin becomes exhausted and cannot accomplish any further ion exchange, the resin must be regenerated. Resin capacity is usually expressed in terms of equivalents per liter (eq/l) of resin. An equivalent is the molecular weight in grams of the compound divided by its electrical charge, or valence. For example, a resin with an exchange capacity of 1 eq/l could remove 37.5 gram of divalent zinc ( $Zn^{+2}$ , molecular weight of 65) from solution.

#### b. Wastewater Purification/Recycle Systems

In usual practice, metal finishing wastewater is treated and then discharged to a river or sewer system; as an alternative, the wastewater can be deionized by ion exchange and reused in the plating process. Wastewater deionization will significantly reduce water consumption and the volume of wastewater requiring treatment, with the following primary economic advantages:

- Water use and sewer fees are reduced.
- Although treatment of pollutants is not eliminated, the size and cost of the pollution control system is significantly reduced.

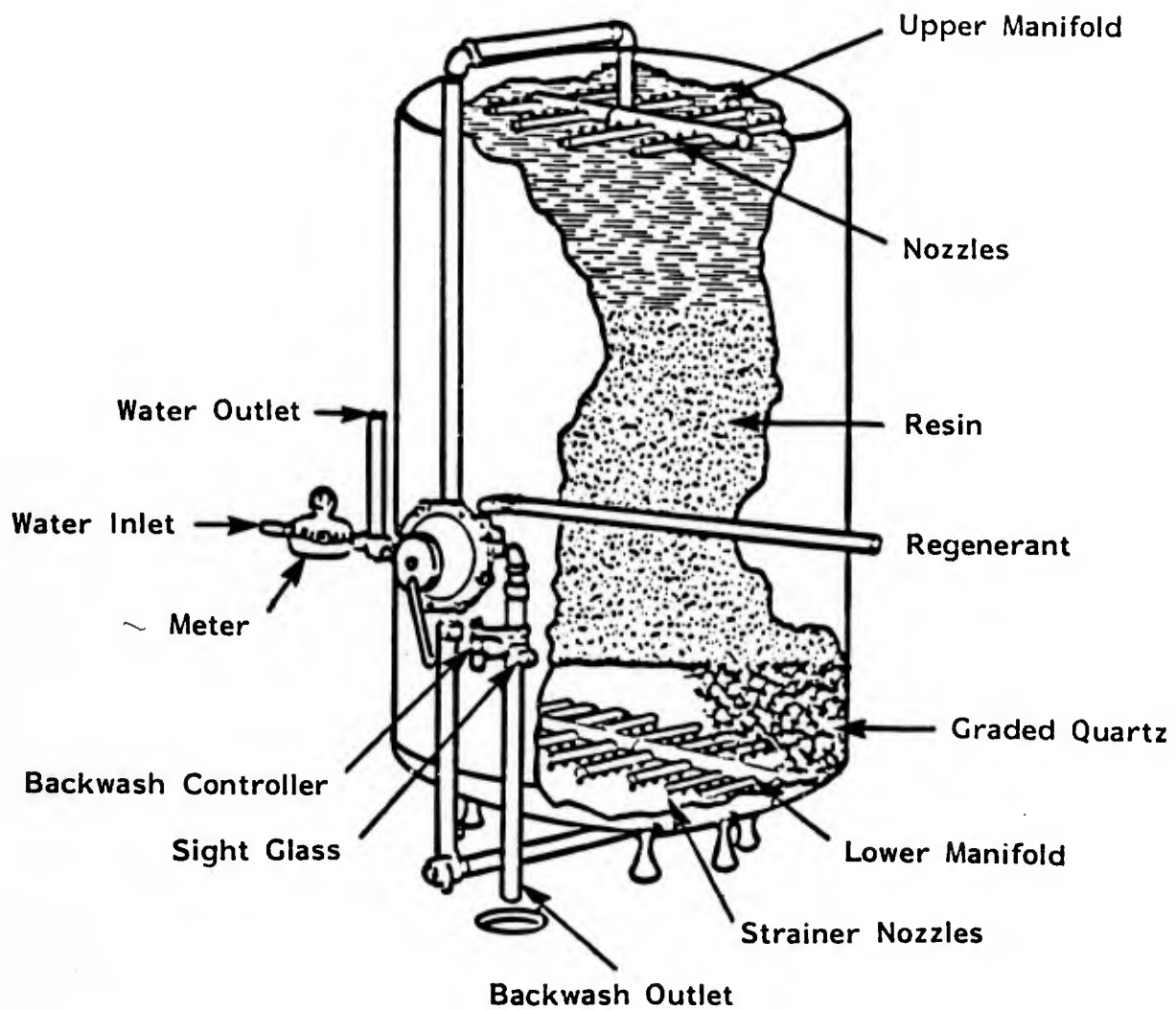

Source: Kunin, R. "Ion Exchange for the Metal Products Finishers," (3 pts) Products Finishing, April-May-June 1959

Figure 31. Typical Ion Exchange Resin Column

Inorganic plating chemicals such as acids, bases, and metal salts are ionized in water solutions and can be removed from process waters by ion exchange. Some dissolved organic compounds, oils, and free chlorine are typically present in mixed wastewaters and their presence constitutes a potential for fouling or deterioration of the ion exchange resin. Electroplating facilities using ion exchange on mixed wastewaters have found the resins to be operable and stable when the recycle system incorporates wastewater pretreatment to remove constituents that degrade the resins (Reference 15).

The usual ion exchange sequence is cationic exchange followed by anionic exchange. The reverse sequence is avoided because passing the solution first through an anion exchange column would increase pH and could precipitate heavy metal hydroxides.

An ion exchange wastewater recycle system is shown in Figure 32. The major process components include:

- Wastewater storage
- Prefilters
- Ion exchange columns
- Regeneration system
- Batch treatment for regenerant solutions
- Deionized water storage

In the most common column configuration, wastewater passes in series through a strong acid cation resin column and then through either a strong or weak base anion resin column. Weak base resins have higher exchange capacities and require less regenerant than do strong base resins. On the other hand, weak base resins are not effective in removing weakly ionized bicarbonates, borates, and silicates, nor can they operate effectively at high pH values. These limitations may not be a concern for metal finishing wastewaters, and weak base resins are recommended. If these anions are present in significant amounts, an anion bed containing both strong and weak base resins can be used. A bed of this kind will approach the higher exchange capacity and regeneration efficiency of a weak base system but provide complete deionization (Reference 15).

To provide uninterrupted system operation when column regeneration is required, two sets of columns are frequently installed. When one set has been exhausted, flow is switched to the off-stream set and the spent columns are regenerated.

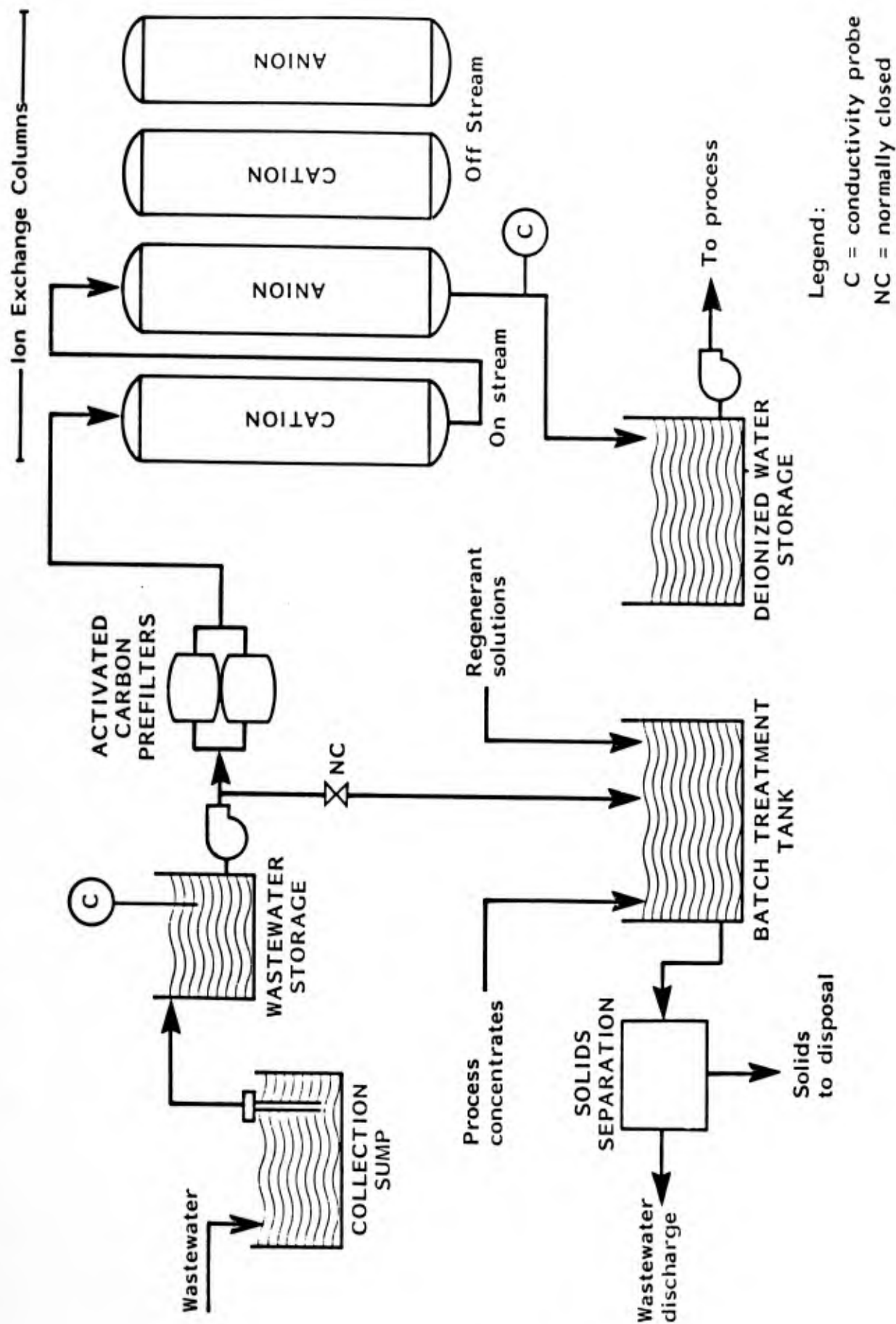

Figure 32. Ion Exchange Wastewater Purification and Recycle System

The pollutants removed by the ion exchange system will be concentrated in the regenerant and wash solutions. These solutions must undergo conventional treatment before being discharged. The type of pollutants present ( $\text{Cr}^{+6}$  and heavy metals would be most common) dictates the treatment sequence that would be required.

A storage tank is used to provide an inventory of water for process needs. The effluent from the ion exchange column should be monitored with a conductivity probe to provide a relative index of the level of dissolved solids in the treated water. When the water conductivity increases to a certain level, the columns are switched and the spent columns are regenerated. Because complete water deionization is not needed for most process applications, the columns are loaded until the maximum allowable level of impurity is reached before they are regenerated; regeneration frequency and system operating costs are thus reduced.

Columns are usually sized as a function of the ratio of wastewater volume to resin volume. Recommended rates vary depending on the application but as a rule range from 2 to 4 gal/min-ft<sup>3</sup> of resin. Higher rates will usually result in higher leakage, but will not affect the quantity of ionic compounds the resin bed can exchange.

Figure 33 shows the cost of the four-column ion exchange system illustrated in Figure 32. The cost is for a skid-mounted unit including columns, resin charge, acid and base regenerant storage, and all interface piping and valves. The columns are normally sized based on a feed rate of 4 gal/min-ft<sup>3</sup> of resin. Ion exchange units for 30 and 100 gal/min would cost \$30,000 and \$64,000, respectively. The cost for a complete system such as that in Figure 32 would be considerably higher. The system could handle all wastewater, with the exception of cyanide wastes. Cyanides should be oxidized before passage through the exchangers. Strong dumps should be sent directly to the batch treatment system.

Operating costs for an ion exchange purification system to treat wastewater containing a variety of heavy metals will include:

- Chemicals for column regeneration
- Destruct chemicals for treatment of concentrated regenerant solutions and purged wash water
- Disposal of the treatment residue
- Labor for column regeneration and operation of the batch treatment system
- Maintenance

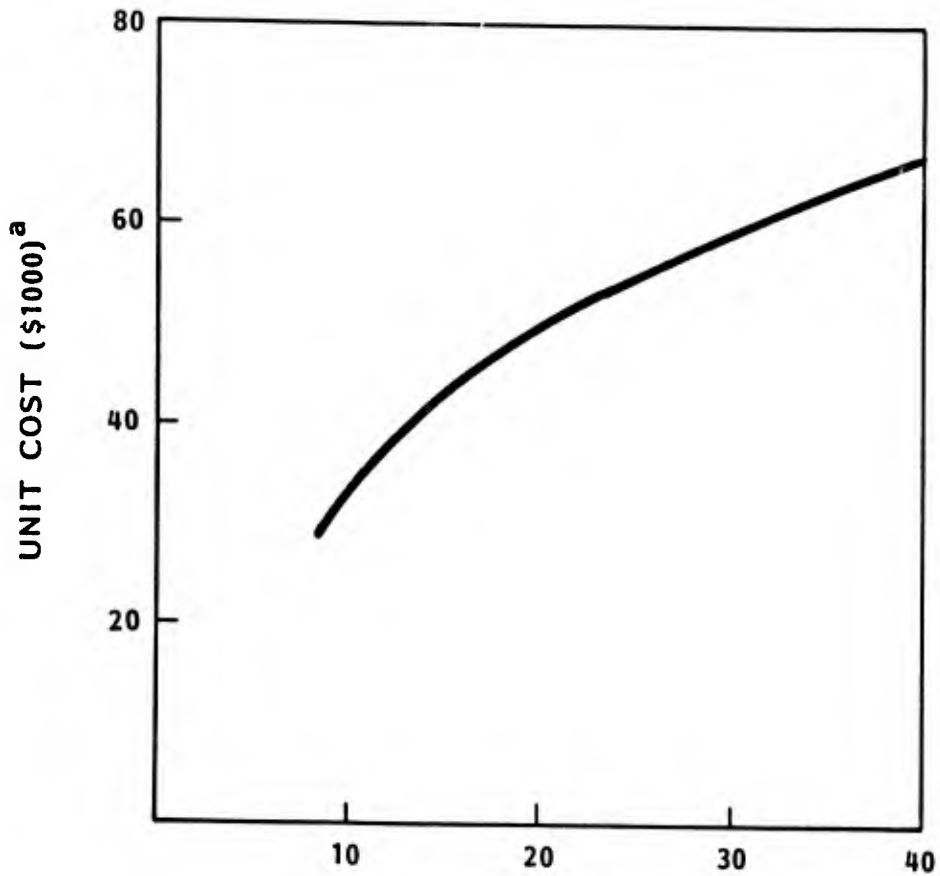

<sup>a</sup>1983 Dollars

Note: Cost is for skid-mounted, preengineered package unit, includes acid and base regenerant storage and all internal piping and valves.

Figure 33. Cost for Wastewater Deionization Units

- Resin and activated carbon replacement
- Utilities

c. End-of-Pipe Systems

Ion exchange can be used in two different ways for end-of-pipe pollution control. The process has been demonstrated as a means of polishing the effluent from conventional hydroxide precipitation to lower the heavy metal concentration further, and it has been used to process untreated wastewaters directly for removal of heavy metals and other regulated pollutants. The two process approaches are shown in Figure 34.

The development of special chelating resins made ion exchange feasible for selective removal of trace heavy metals from a water solution containing a high concentration of similarly charged, nontoxic ions. These resins exhibit a strong selectivity, or preference, for heavy metal ions over sodium, calcium, or magnesium ions. Weak acid cation resins also display a significant preference for heavy metal ions, and, in some applications, they are superior to the chelating resins in performance characteristics.

In both end-of-pipe systems, wastewater pretreatment requirements consist of pH adjustment to ensure that pH is within the operating range of the resin, and filtration to remove suspended solids that would foul the resin bed. In a polishing system, the upstream treatment process provides the pretreatment. The pollutants removed from the wastewater are concentrated in the ion exchange regenerant solution.

In the ion exchange is a polishing system (Figure 34a), the regenerants can be treated in the conventional hydroxide treatment system. If the ion exchange is used for total pollutant removal (Figure 34b), the regenerants can be treated in a small batch treatment system using conventional processes.

Figure 35 shows the performance of a chelating resin for removal of nickel and copper. The data were derived from an EPA-sponsored pilot study of ion exchange polishing. The resin column treated approximately 900 bed volumes (bv) of wastewater before its exchange capacity was exceeded, which translates to each cubic foot of resin treating approximately 7,000 gallons of wastewater before regeneration.

Performance of a weak acid cation resin for removal of zinc and cadmium is given in Table 25. The column feed treated in this example is more typical of untreated wastewater. Zinc breakthrough occurred in this example after approximately 1,500 gallons has been treated per cubic foot of resin.

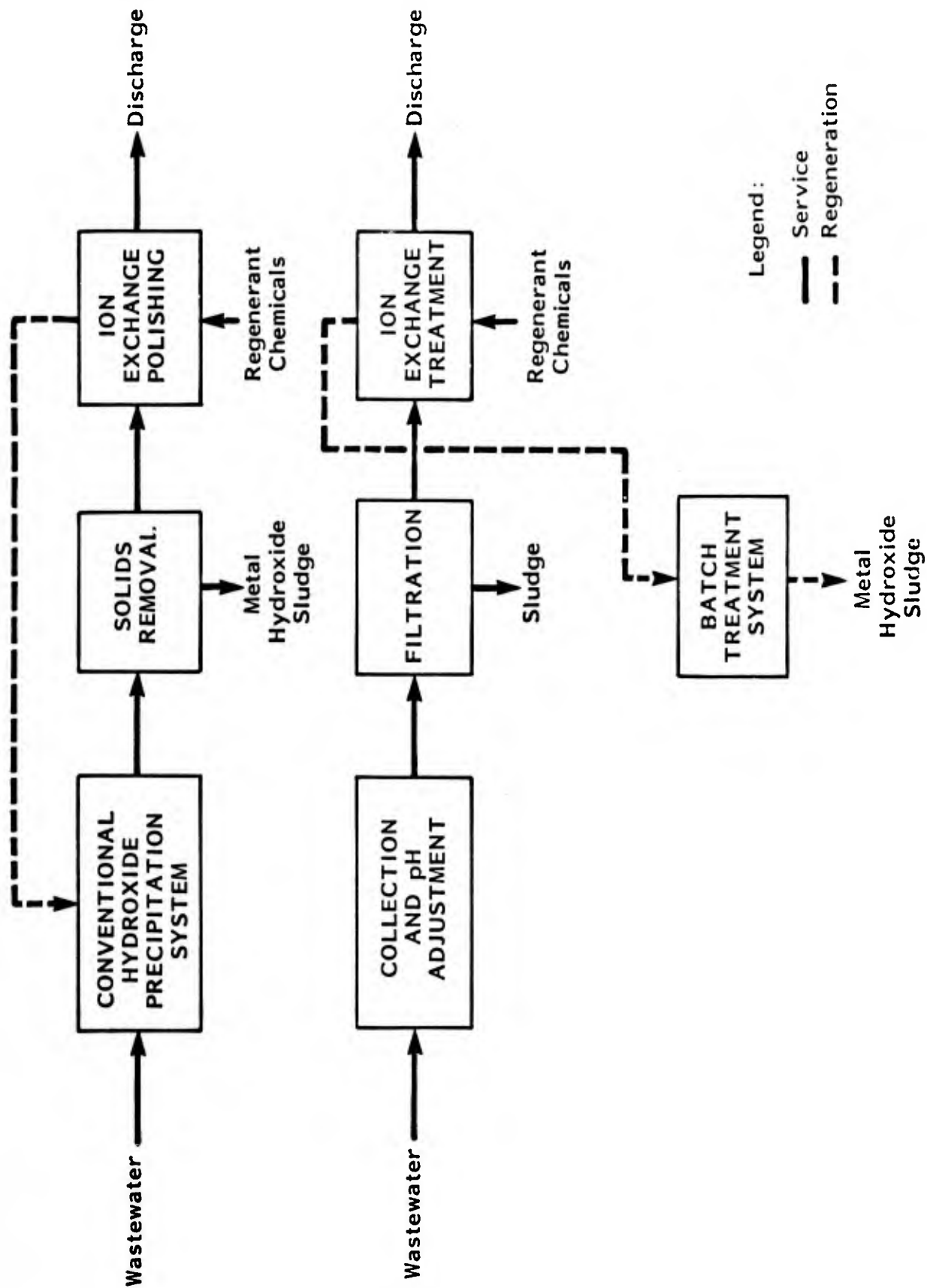
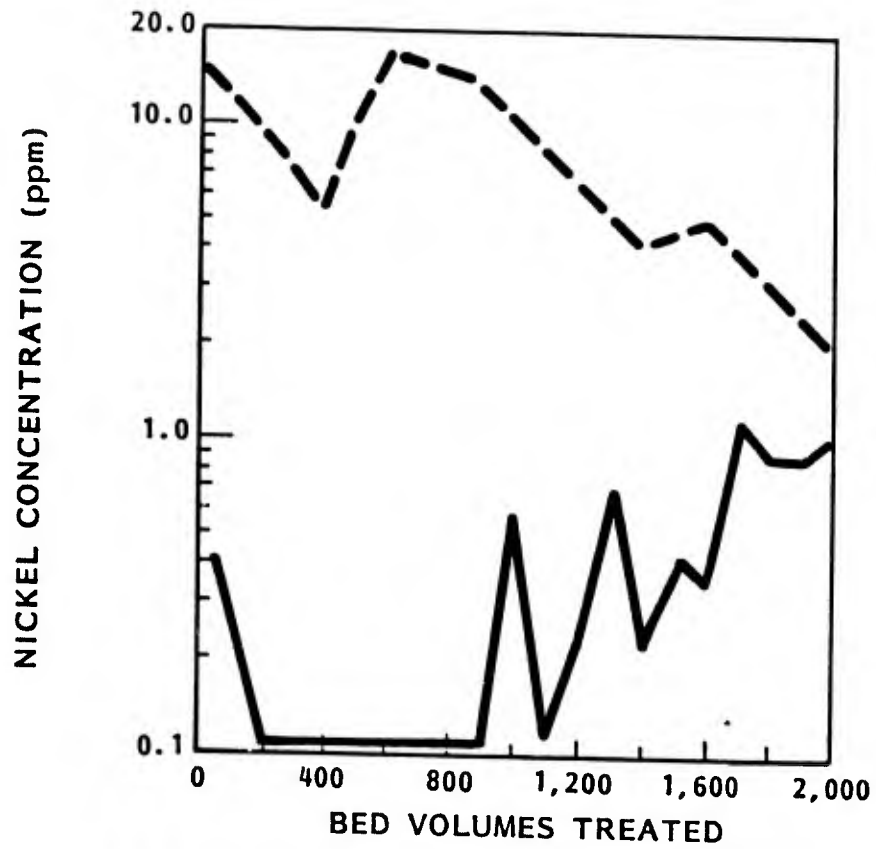
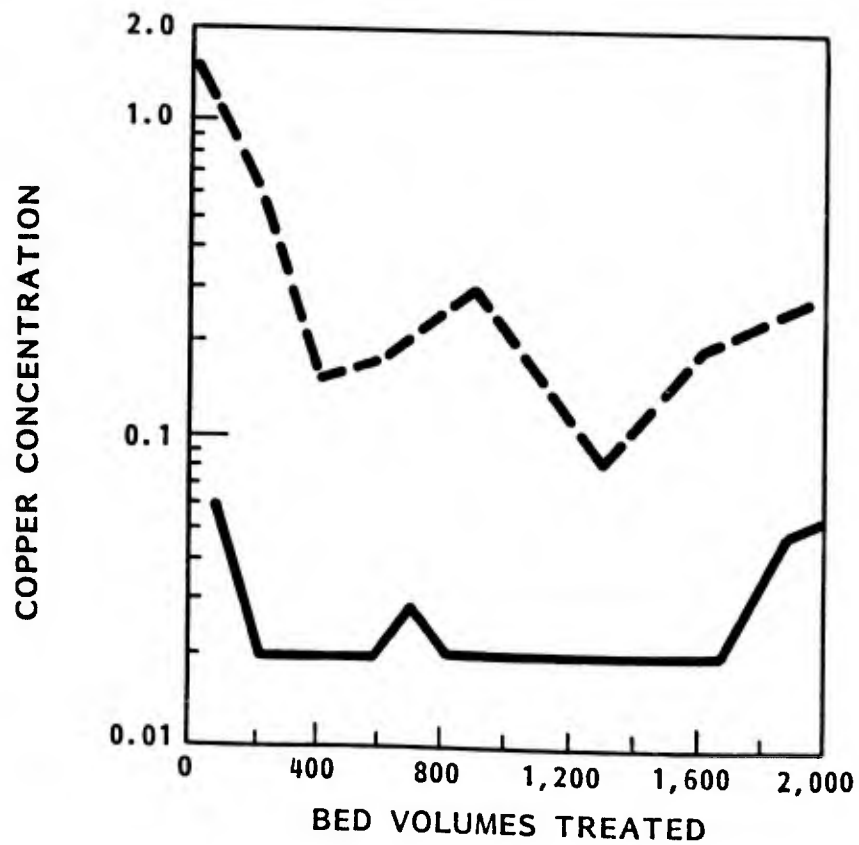

Figure 34. Ion Exchange Systems: (a) Polishing, (b) End-of-Pipe Treatment

(a)



(b)



Note: Feed conditions (average): 0.1 ppm Cr, 275 ppm Ca, 2,200 ppm Na, 0.05 ppm Zn 80 ppm  $\text{NH}_4$ , pH = 8.4, 8bv/h.

Figure 35. Metals Removal Data: (a) Nickel and (b) Cooper

TABLE 25. REMOVAL OF ZINC AND CADMIUM FROM WASTEWATER BY WEAK ACID CATION RESIN

Bed volume sampled	Total loading (gal/ft <sup>3</sup> resin)	pH	Leakage (ppm)		
			Zinc	Cadmium	Calcium
10.....	75	10.1	0.01	0.01	1
25.....	190	10.1	0.01	0.01	3
35.....	260	8.3	0.01	0.01	53
55.....	410	7.2	0.01	0.01	303
70.....	520	6.0	0.16	0.01	338
100.....	750	7.0	0.1	0.01	385
150.....	1,120	6.9	0.13	0.01	404
160.....	1,200	6.8	0.25	0.01	405
185.....	1,230	6.8	0.37	0.01	407
175.....	1,300	6.7	0.56	0.01	404
190.....	1,420	6.8	0.64	0.01	395
200.....	1,500	6.8	1.3	0.01	394
225.....	1,680	6.8	6	0.01	395

\*Na form.

Note.—Feed characteristics: 391 ppm Ca, 91 ppm Zn, 0.12 ppm Cd, 350 ppm Mg, 57 ppm Na, 3.5 ppm Mn, 0.12 ppm Ni; pH = 4.7; 8-bv/h (1-gal/min/ft<sup>2</sup>) flowrate.

SOURCE: Rohm and Haas Company, "Ion Exchange in Heavy Metals Removal and Recovery," Amber Hilite No. 162, Philadelphia PA, Rohm and Haas Company, 1979.

The cost of the ion exchange system, whether for polishing or total treatment, will depend on the required resin volume.

In polishing applications, the metal concentration in the column feed is generally so low that hydraulic limitations determine minimum column size. A maximum loading of 5 gal/min-ft<sup>3</sup> of resin is a reasonable basis for design. For total treatment, column size is often specified so as to have a reasonable regeneration frequency.

Figure 36 shows the cost of dual column systems for either application. Again, the price is strickly for the columns, resin charge, and the acid and base regenerant systems. The cost of any auxiliary equipment (e.g., prefilters, batch treatment system) would increase the total cost of the process.

#### d. Metal Recovery Systems

Ion exchange has been used for recovery of metal salts and chromates for rinse waters following plating baths. The Reciprocating Flow Ion Exchanger (RFIE) is the kind of ion exchange system most widely used for chemical recovery from plating rinses (Reference 15). This proprietary unit was especially developed for purifying the bleed stream of a large volume solution such as the overflow from a plating rinse tank. It operates on the principle that, for the short period of time the unit goes off stream for regeneration, the buildup of contaminants in the rinse system is negligible.

The RFIE units are more attractive than fixed-bed systems for plating chemical recovery because the columns use smaller resin volumes and, therefore, capital costs and space requirements are usually lower. The units incorporate regenerant chemical reuse techniques to reduce operating costs and yield higher product concentration for recycle. They are sold as skid-mounted package units, which are automated to minimize operating labor requirements. Two kinds of basic units are available for drag-out recovery: one for chromic acid recovery and one for metal salt recovery. Figure 37 describes the components of a chromic acid unit and shows its operating cycle.

RFIE units are recovering plating drag-out from nickel, copper, zinc, tin, and cobalt plating rinses. The major area of application is for nickel plating baths. Two basic units are used for metal recovery. One employs a cation bed to reclaim the metal ions and an anion bed to remove the counterions; the deionized water is recycled to the rinse station. For applications where only the metal is to be recovered, the anion bed is eliminated and the metal-free water is discharged. The operating cycle of the unit is essentially the same as the chromate recovery system.

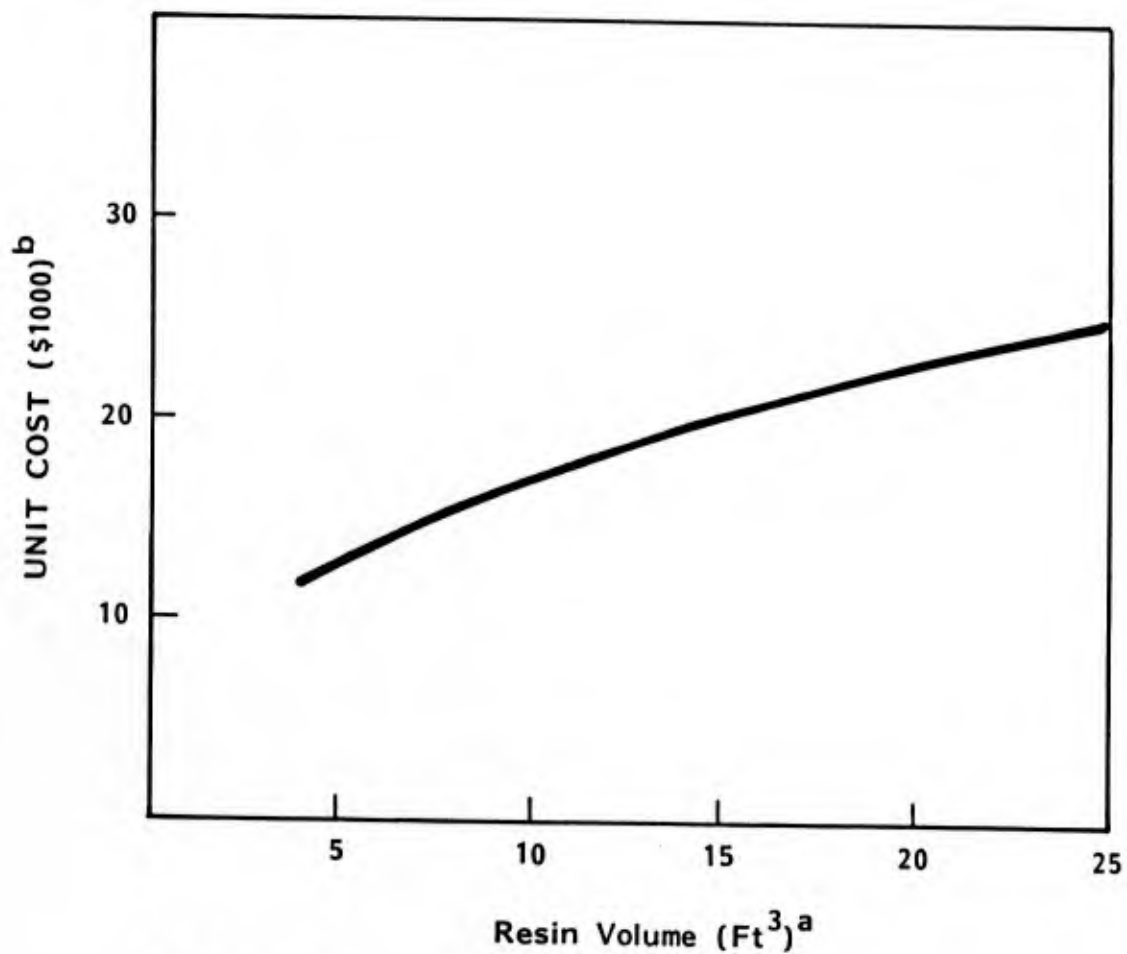

<sup>a</sup>Per Column

<sup>b</sup>Skid-mounted unit with weak acid cation resin acid and base regenerant system and all internal piping and valves, 1983 dollars.

Figure 36. Unit Cost of Dual Column Resin System

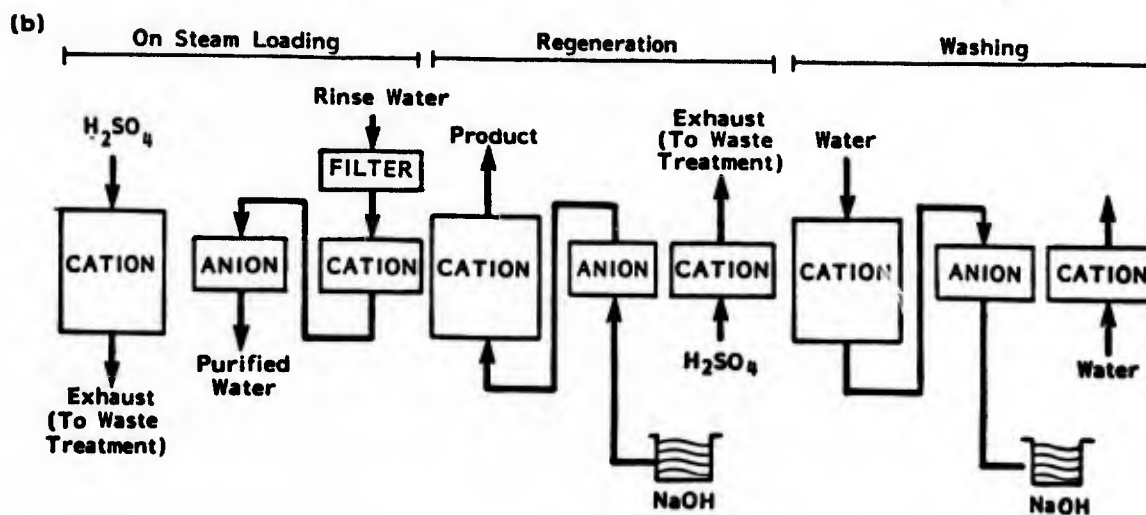
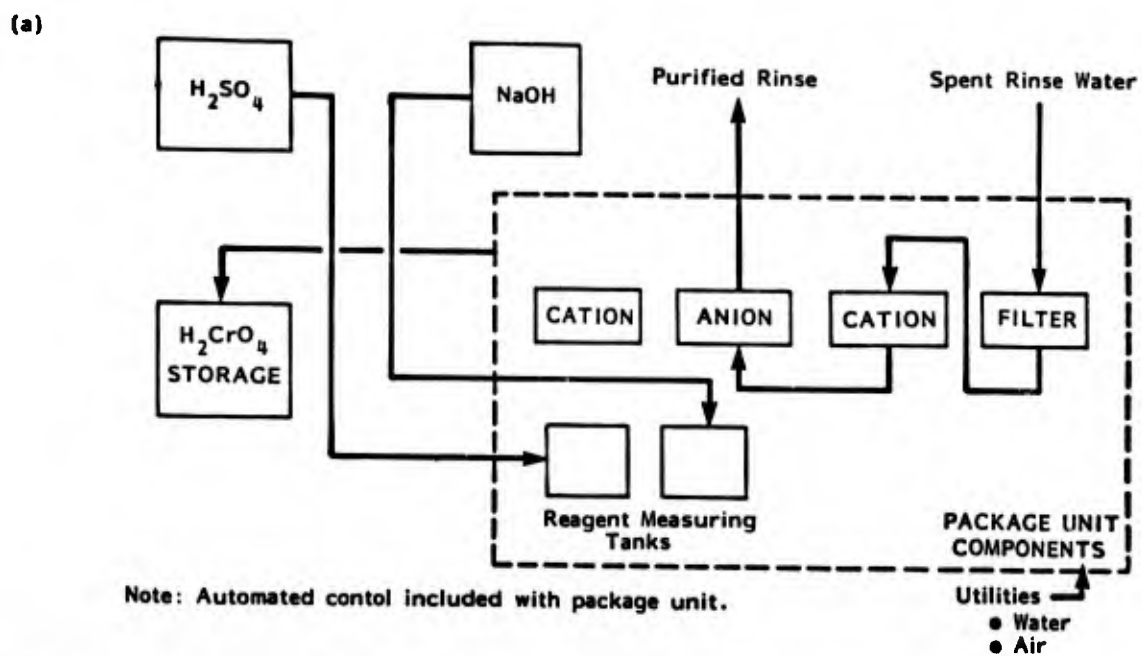

Figure 37. Chromic Acid Recovery RFIE Systems  
 (a) Hardware Components, (b) Operating Cycle

The cost of the skid-mounted RFIE units ranges from \$25,000 to \$50,000 for chromic acid recovery. These units have a capacity for recovering between 2 and 10 lb/h of  $\text{CrO}_3$ . The metal salt recovery units cost between \$20,000 and \$40,000, depending on capacity needed. Their capacity ranges from 5 to 25 lb/h of nickel sulfate recovery.

### 3. Operation and Maintenance Demands

Ion exchange must be considered a more sophisticated treatment process than conventional techniques. The resins used are highly specialized organic chemicals, they are costly, and if they are fouled they lose their effectiveness. Ion exchange is not recommended as a black-box add-on technology. Frequent failures of the process have occurred where proper screening of the application did not precede the installation. Ion exchange is a versatile process and can provide treatment capabilities more efficiently than competing technologies. Its application, however, requires access to someone with a background in chemistry and engineering to ensure reliable operation.

## D. SODIUM BOROHYDRIDE

### 1. Summary and State of Technology Development

Sodium borohydride ( $\text{NaBH}_4$ ) was discovered by H. I. Schlesinger, H. C. Brown, and co-workers at the University of Chicago in 1943. Commercial production was pioneered by Ventron Corporation, Beverly, Massachusetts (then known as Metal Hydrides Incorporated) in the late 1960's. The substance has since found numerous applications in organic and inorganic chemical processing.

Sodium borohydride (often called SBH) is a strong reducing agent that can precipitate many heavy metals in their elemental form from an alkaline solution. Treatment of a plating waste stream containing only one metal can produce a precipitated metal suitable for reclaiming or recycling to the process. For treating wastewater that contains mixed metals, SBH precipitation offers the advantage of producing a very low volume of sludge compared with conventional hydroxide precipitation. In addition, the process can remove metals to lower concentrations than can conventional treatment (Reference 16).

SBH treatment has been successfully applied to the heavy metal removal and recovery at several full-scale plants. E. I. DuPont de Nemours and Company uses the process to reduce pollution and recover lead in its tetraalkyl lead production facilities at Deepwater, New Jersey, and Antioch, California. International Mineral and Chemicals recovers and recycles mercury from its chlorine and caustic production facility at Orrington, Maine. Powers Chemco, Inc., a large manufacturer of lithographic film, removes cadmium and silver from wastewater at

its Glen Cove, Long Island plant. Silver is recovered in the process. Although no specific applications have been noted for wastewater treatment in the electroplating industry, the process has been shown to be effective in removing most heavy metals.

Sodium borohydride is manufactured by Thiocol Corporation, Ventron Division, 150 Andover Street, Danvers, Massachusetts 01923.

## 2. Process Description

Sodium borohydride is available as a 98 percent free-flowing powder or as a stabilized water solution (SWS) of 12 percent sodium borohydride in caustic soda. The SWS form is more commonly used because it is easy to handle.

In treatment of wastewater from plating operations, the pH is first adjusted to 8-11, then SBH is added to the agitated solution. A reaction time of 30 minutes is necessary to ensure complete reduction of the metals. Because hydrogen is evolved during the reaction, the reaction vessel must be vented. A second agitated vessel with 30 minutes retention must be provided to lower the pH to about 8 by the addition of acid. This operation serves to destroy the unreacted SBH and lower the pH to a level suitable for discharge to the sewer system. Additional hydrogen evolves in this step. The reaction with SBH is followed by conventional clarification and solids removal operations.

Chromates in the wastewater are reduced by SBH to the trivalent state ( $\text{Cr}^{+3}$ ), then precipitate as the metallic hydroxide (Reference 16). Owing to the relatively high cost of SBH reduction, however, the alternative method is segregation of the chromates and pretreatment with sodium metabisulfite before the SBH treatment.

## 3. Operation and Maintenance Requirements and System Performance

Operational requirements of a well-designed SBH treatment system consist primarily of maintaining a sufficient supply of treatment chemicals. Maintenance requirements are those commonly associated with mechanical components such as pumps and agitators. Routine cleaning of pH measuring probes is also necessary. No unusual maintenance problems are associated with the SBH process.

#### 4. Residuals Generated

The sludge from the SBH process consists of a mixture of elemental metals and metallic hydroxides. The composition of the wastewater determines how the quantity of sludge compares with that produced by conventional hydroxide precipitation. It is therefore necessary to review all parameters carefully before designing an SBH treatment system. Laboratory treatability tests of wastewater samples are highly recommended.

#### 5. Cost Factors

The theoretical level of SBH needed to reduce the soluble metal ion to the base metal is given in Table 26. The treatment level is given for both 97 percent active powder and a stabilized water solution of 12 percent SBH and caustic soda. The actual SBH dose may vary depending on actual reduction conditions and possible side reactions. It is generally desirable to maintain an excess of SBH through the separation step to prevent reoxidation of the reduced metal.

TABLE 26. LEVEL OF SODIUM BOROHYDRIDE THEORETICALLY REQUIRED FOR REDUCTION OF VARIOUS METAL CATIONS

Metal	Oxidation State	Sodium Borohydride (g NaBH <sub>4</sub> /kg metal)	SWS (mL SWS/kg Metal)
Cobalt	Co <sup>+2</sup>	167	1,000
Copper	Cu <sup>+2</sup>	143	850
Gold	Au <sup>+3</sup>	72	430
Iridium	Ir <sup>+4</sup>	100	600
Lead	Pb <sup>+2</sup>	46	270
Mercury	Hg <sup>+2</sup>	48	280
Nickel	Ni <sup>+2</sup>	167	1,000
Palladium	Pd <sup>+2</sup>	91	540
Platinum	Pt <sup>+4</sup>	100	600
Rhodium	Rh <sup>+3</sup>	143	850
Silver	Ag <sup>+</sup>	43	260

Table 27 gives the investment costs for 30-gal/min and 100-gal/min end-of-pipe systems. Table 28 gives estimated operating costs.

TABLE 27. ESTIMATED INSTALLED INVESTMENT COSTS  
FOR SODIUM BOROHYDRIDE TREATMENT SYSTEM

Unit Capacity (gal/min)	Estimated Installed Cost <sup>a</sup>
30	\$105,300
100	\$145,275

<sup>a</sup>Assumes chromium reduction and cyanide oxidation are completed before sodium borohydride treatment.

TABLE 28. ESTIMATED VARIABLE OPERATING COSTS<sup>a</sup>  
FOR END-OF-PIPE TREATMENT

Item	Cost per Unit	Annual Quantity		Annual Cost (\$)	
		30-gal/min Capacity	100-gal/min Capacity	30-gal/min Capacity	100-gal/min Capacity
Labor	\$15/h	750 h	1,000 h	11,250	15,000
Maintenance at 4% of investment)				4,200	5,800
Electricity	\$0.05/kWh	29,840 kWh	44,760 kWh	1,492	2,238
Chemicals				<u>2,207</u>	<u>7,355</u>
Total				19,149	30,393

<sup>a</sup>Costs do not include those incurred for disposal of the resulting sludge, for cyanide destruction, or for chromium reduction.

NOTE: Operating two shifts per day, 250 days per year.

## E. OZONE OXIDATION

### 1. Summary and State of Technology Development

Ozone has been used for many years as a strong oxidizing agent in the biological treatment of wastewater. Its application for the oxidation of cyanides in wastewater was demonstrated on a plant scale in two instances. Ozodyne Corporation, San Diego, California, operated an ozone system at San Diego Plating Co., a shop that recycles automotive bumpers. PCI Ozone Corporation demonstrated cyanide destruction with ozone at Sealectro Corporation, Mamaroneck, New York, under funding from EPA's R&D branch in Cincinnati.

### 2. Process Description

Figure 38 illustrates the process employed at San Diego Plating. Plant wastewaters are collected in a holding tank from which the treatment system is fed. Rinse waters that contain hexavalent chromium ( $\text{Cr}^{+6}$ ) are pretreated with sodium bisulfite to reduce the chromium to the trivalent state ( $\text{Cr}^{+3}$ ) before the waters are discharged to the holding tank. The solution from the holding tank is pumped into an agitated mixing tank where calcium oxide ( $\text{CaO}$ ) is automatically added to raise the pH to 10.5-11.5. The resulting calcium hydroxide reacts with the heavy metal cations in solution to form metal hydroxides that are insoluble in the alkaline environment.

The wastewater containing suspended heavy metal hydroxides and cyanides is then pumped to the ozone reactor system. Ozone gas under negative pressure is drawn into the waste stream with an eductor. Immediately following this mixing, the wastewater, containing dissolved ozone and ozone gas, enters a reactor. The wastewater is injected tangentially into the rim of a small, spinning stainless steel bowl similar to a centrifuge. Rim speeds can be as high as 40,000 r/min. The wastewater is shattered into a cloud or mist, thereby enormously increasing the surface area of contact between the ozone and the wastewater. From the reactor, the wastewater is pumped to a rotary vacuum filter where the waste stream is dewatered. Solids are collected for disposal while the filtered effluent is sent to the sewer (Reference 17).

The treatment system at Sealectro was similar, with the exception of the ozone reaction tank. In this instance the ozone reaction tank consisted of two compartments: the lower, larger compartment where the wastewater is treated by ozone, and the upper, smaller compartment where the spent ozone is diffused into the incoming cyanide waste. The upper compartment serves to remove unreacted ozone from the off-gas to ensure that the ozone is consumed completely and to prevent it from escaping through the vent to the outside atmosphere.

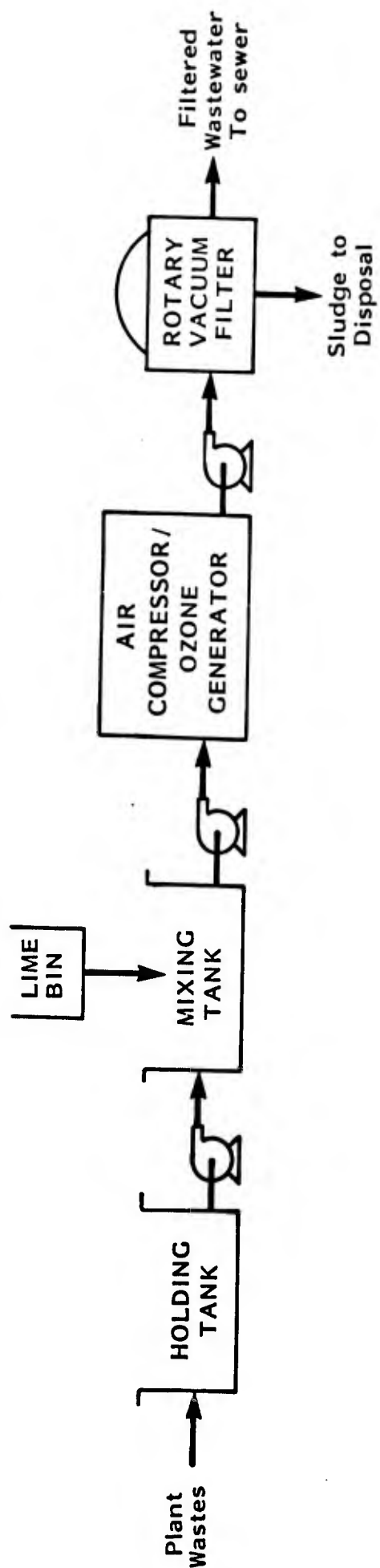

Figure 38.. Diagram of Ozone Treatment System at San Diego Plating

### 3. Residuals Generated

Experience at San Diego Plating suggests that metal oxides are produced, rather than metallic hydroxides, which would account for the relatively low sludge volume. The vacuum filter used for dewatering produces sludge with 75 percent solids--a much higher percentage than that achievable with sludge from conventional precipitation (Reference 17). To date, no tests have been performed on the sludge to determine its leachability. It must therefore be considered hazardous until proven otherwise.

### 4. Operation and Maintenance Requirements and System Performance

The operation and maintenance requirements of the ozone systems are similar to those of conventional systems. About 1 hour operator time is needed for application of the filter aid, adjustment of the scraper blade on the filter, and startup of the air compressor and pumps. Routine collection and removal of the solids is necessary.

Table 29 summarizes the performance of the San Diego Plating installation.

TABLE 29. PERFORMANCE OF OZONE TREATMENT SYSTEM AT SAN DIEGO PLATING

Parameter	Influent (mg/l) <sup>a</sup>		Effluent (mg/l) <sup>a</sup>		Average % Removal
	Range	Average	Range	Average	
Cyanide	3.75-0.05	1.02	0.87-<0.02	0.08	>92.5
Total chrome	6.62-0.82	1.41	1.55-0.05	0.40	>71.6
Copper	33.0-5.05	9.45	1.32-0.04	0.05	99.5
Nickel	60.0-10.20	20.32	0.37-<0.10	0.13	>99.4
TSS	559-35.0	135	93-<1	11.6	>91.5
pH	12.2- 3.40	6.4 <sup>b</sup>	12.4-5.8	8.4 <sup>b</sup>	--

<sup>a</sup>Except pH.

<sup>b</sup>Median.

NOTE: Average solids content of sludge = 74 percent.

### 5. Cost Factors of Treatment

Table 30 gives the investment costs for a 30-gal/min (10-gal/min cyanide stream at 15 mg/l CN) and a 100-gal/min (33-gal/min cyanide stream at 15 mg/l CN). Table 31 gives estimated operating costs.

TABLE 30. ESTIMATED INSTALLED INVESTMENT COSTS  
FOR OZONE TREATMENT SYSTEM

Unit Capacity <sup>a</sup> (gal/min)	Estimated Installed Cost (\$)
30	79,000
100	95,000

<sup>a</sup>Cyanide waste streams are assumed to be 10-gal/min for a 30-gal/min system and 33-gal/min for 100-gal/min capacity.

TABLE 31. ESTIMATED VARIABLE OPERATING COSTS<sup>a</sup>

Item	Cost per Unit	Annual Quantity		Annual Cost (\$)	
		30 gal/min Capacity	100 gal/min Capacity	30 gal/min Capacity	100 gal/min Capacity
Labor	\$15/h	260 h	390 h	3,900	5,850
Maintenance (at 4% of investment)				3,172	3,807
Electricity	\$0.05/kWh	10,350 kWh	34,500 kWh	518	1,725
Total				7,590	11,382

<sup>a</sup>Costs do not include those incurred for disposal of the resulting sludge or chromium reduction.

NOTE: Operating two shifts per day, 250 days per year.

## F. THERMAL OXIDATION

### 1. Summary and State of Technology Development

Of the variety of processes developed for the treatment of cyanide-bearing wastes, alkaline chlorination has been the accepted method for about 20 years. In this process, cyanides are first oxidized to cyanates and then to carbon dioxide and water.

Cyanides are relatively unstable compounds that decompose at elevated temperatures. Cyanide plating baths are conventionally maintained at ambient temperature to prevent this decomposition. Likewise, evaporative recovery stills are designed to operate under vacuum so that the solutions boil at about 105°F, limiting decomposition to a minimum. Attempts have been made to exploit the instability of cyanides for use in treatment of concentrated waste solutions. Laboratory tests (Reference 18) have proven that cyanides can be completely destroyed by thermal decomposition. Where the pH is 11 or more, the treated effluent contains neither cyanide nor a residual oxidizing agent. In conventional chlorine treatment, residual Cl<sub>2</sub> in the effluent is toxic to fish. In addition, toxic cyanogen chloride cannot be evolved by thermal decomposition, as is possible with chlorination.

In late 1977, the Ontario Research Foundation conducted a series of tests on thermal treatment of cyanides as a method for complete cyanide destruction without the use of expensive chemicals (Reference 19). It was found that cyanides could be destroyed completely when heated under pressure to temperatures higher than 400°F for 2 hours.

As a followup to the laboratory program, the American Electroplaters' Society (AES) funded a commercial demonstration of the batch treatment for high strength cyanides at Whyco Chromium's plant at Thomaston, Connecticut. Complete results of the project have not yet been published.

### 2. Process Description

The thermal process involves heating the cyanide solution to an elevated temperature until the complete destruction is accomplished. A process (Figure 39) based on the AES research is designed to destroy the solutions in 55-gallon drums. The pressurized system involves the placing of a 55-gallon drum of strong (50,000 mg/l) cyanide solution into a specially designed reactor and heating it under pressure to 527°F for 2 hours. The reactor is then cooled to 212°F by flashing off water from the system at the end of the reaction. The cool-down process takes approximately 30-60 minutes. Table 32 gives laboratory results on which the design was based.

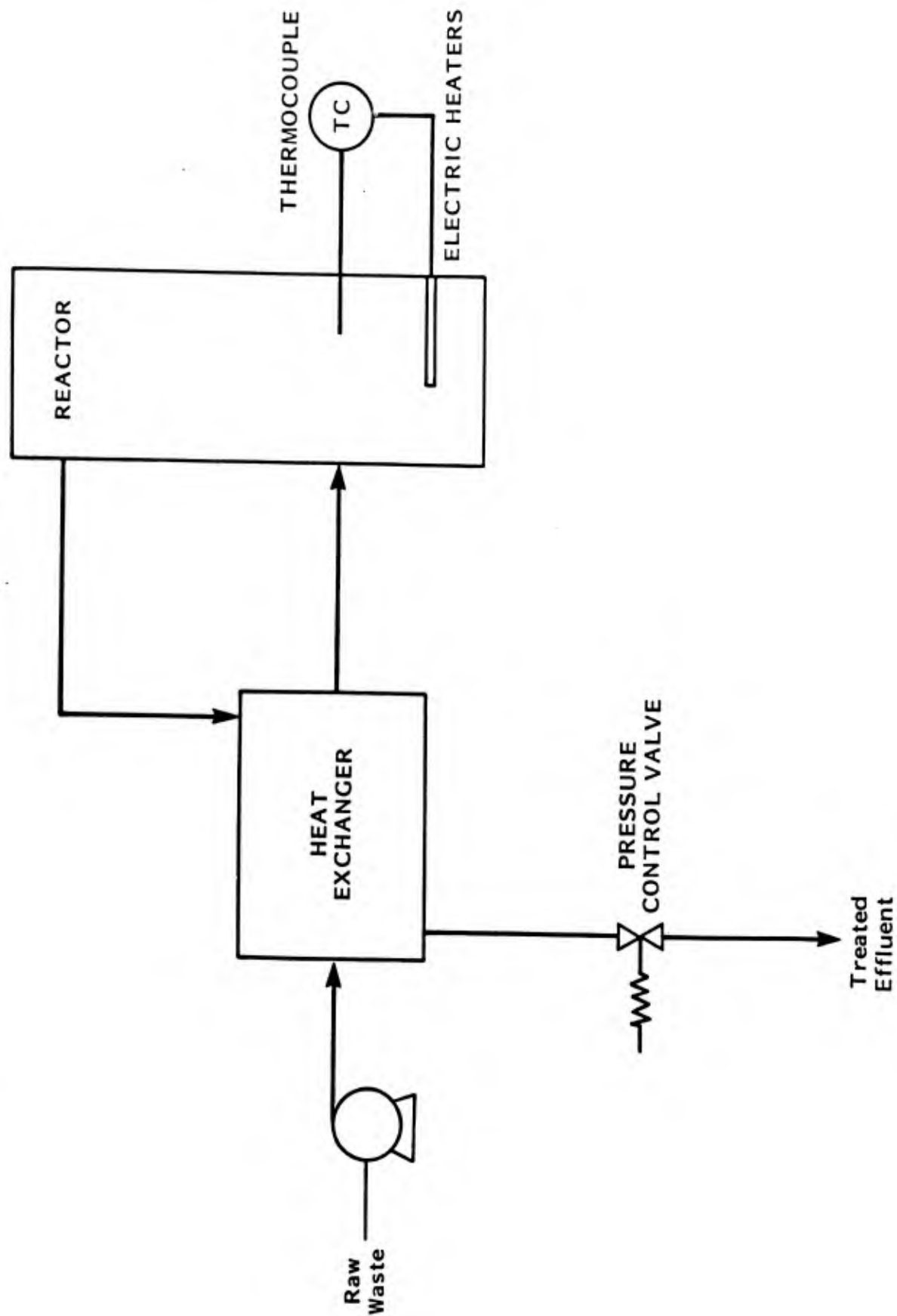

Figure 39. Process Flowsheet - Pressurized Thermal Destruction of Cyanides

TABLE 32. CYANIDE REMOVAL FROM ALKALINE DESCALER  
AT 477°F AND 600 lb/in<sup>2</sup> GAUGE

Item	Total Cyanide Concentrations (mg/l)	
	Batch Process	Continuous Process
Feed	50,000	300
Reactor residence time (min):		
0	12,000	300
15	2,300	60
30	450	15
60	15	0.5
90	0.6	0.02
120	0.02	--

The process is promising for use in the destruction of concentrated cyanide solution. Energy requirements of the system, however, make its application for treatment of dilute rinsewater questionable.

Another process suitable for dilute waste solutions is shown in Figure 40. This process features an atmospheric still, operating under total reflux until the cyanide decomposition is complete.

### 3. Operation and Maintenance Requirements and System Performance

The only operational requirement established to date is the consumption of 675,000 Btu to process 150 gallons of wastes in the drum treatment system. The reactor is designed to be heated electrically with a 54 kW heater.

Because both systems are based on laboratory results, maintenance requirements and system performance have not yet been established.

### 4. Residuals Generated

The heavy metals remaining after treatment of cyanide wastes in the reactor must be removed by sulfide or hydroxide precipitation. No quantitative data are available at this time.

### 5. Cost Factors

Research performed thus far has not addressed the capital cost associated with a thermal decomposition reactor. Operating costs for treatment of concentrated cyanide wastes should be significantly lower than the equivalent chemical treatment costs and on a par with those of electrolytic decomposition.

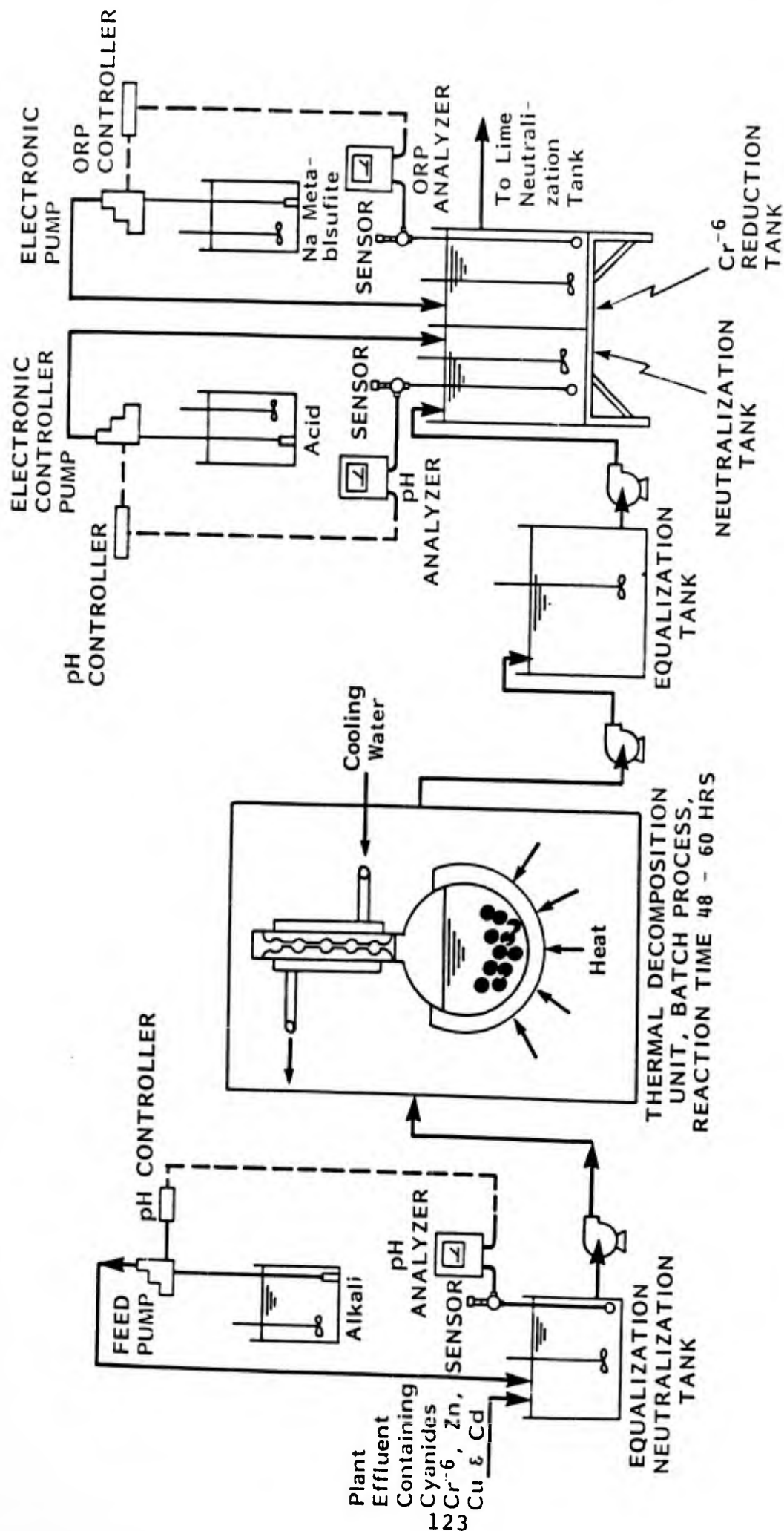

Figure 40. Process Flowsheet - Atmospheric Still for Thermal Decomposition of Cyanides

## G. FREEZE CRYSTALLIZATION

### 1. Summary and State of Technology Development

Freeze crystallization was first investigated as a means of desalinating water. The research and development program was initiated in 1952 by several U.S. companies, including Carrier, Colt, Struthers, Koppers, Rocketdyne, and AVCO. The earliest work concluded that the process was uneconomical. Subsequently, AVCO adapted the idea to treat industrial wastes and patented the Crystalex® process.

The principle underlying freeze crystallization is that, when an aqueous solution containing dissolved contaminants is frozen, ice crystals are formed from uncontaminated water, leaving the contaminants concentrated in the remaining solution. The ice crystals can then be separated from the solution by mechanical means, washed, and melted to yield fresh water. The concentrated contaminant solution can be reused in some manner or can be discarded (Reference 20).

Problems with the process include handling and separating the ice-contaminant slurry and washing the ice crystals free of contaminants. However, the use of direct-contact heat exchange and low operating temperatures minimizes the problems of scale formation and corrosion that are typical of processes such as evaporation (Reference 21).

AVCO has conducted small-scale experiments using its laboratory freeze unit on various industrial wastes. To make the process more effective, a second-stage freezer (the Concentrex Process) was added, and eutectic freezing was proposed. Metal finishing wastes containing heavy metals were among the wastes treated by AVCO with some degree of success (Reference 22).

According to AVCO representatives, their company dropped development of the process in 1978, and the license for the technology was sold to a group of AVCO researchers who left and formed their own company.

To date, no known freeze crystallization processes are employed at electroplating facilities.

### 2. Process Description

Freeze crystallization of electroplating waste streams involves the following steps:

- Heat exchange
- Freezing

- Washing
- Melting
- Refrigerant or energy recovery

There are basically two forms of the freezing process (Reference 23):

- Vacuum flash/vapor compression (VFVC), in which water itself is the refrigerant
- Secondary refrigerant freezing (SRF), in which butane or a halogenated hydrocarbon such as Freon® is the refrigerant

In the SRF process, metal-laden rinse water is pumped through a heat exchanger, as illustrated in Figure 41. The rinse water is cooled by melted product water and pumped into a freezer. An immiscible refrigerant, such as Freon®, is mixed with the rinse water. As the refrigerant evaporates, the solution is cooled and a slurry is formed of ice and concentrated metal-laden solution. The refrigerant vapor is pumped out of the freezer with a compressor. The slurry is pumped from the freezer to a counterwasher, where the concentrated solution adhering to the ice crystals is removed (Reference 24).

The counterwasher is a vertical vessel in which the ice slurry forms a bed of moving crystals that is counter-currently washed by the fresh water product, yielding contaminant-free ice. The clean ice is then melted, using the heat of condensation of the compressed refrigerant. This system can be designed with multiple-stage crystallization to improve the purity of the crystals and to gain economic advantages (Reference 25).

Because of incomplete heat exchange and a number of other factors, more refrigerant is vaporized than can be condensed by the melting ice. Thus, a heat removal system is needed to maintain thermal equilibrium. Such a system consists of a compressor that raises the temperature and pressure of the excess vapor so that it will condense on contact with ambient cooling water (Reference 26).

### 3. Operation and Maintenance Requirements and System Performance

The freeze crystallization process offers several advantages over some other treatment technologies. For example, because to be concentrated, the water is frozen in direct contact with the refrigerant, there are no heat transfer surfaces of membranes to be fouled by the concentrate or other contaminants. Suspended solids will not affect the freezing process and need be removed only as required by the end use intended for the recovered products (Reference 27).

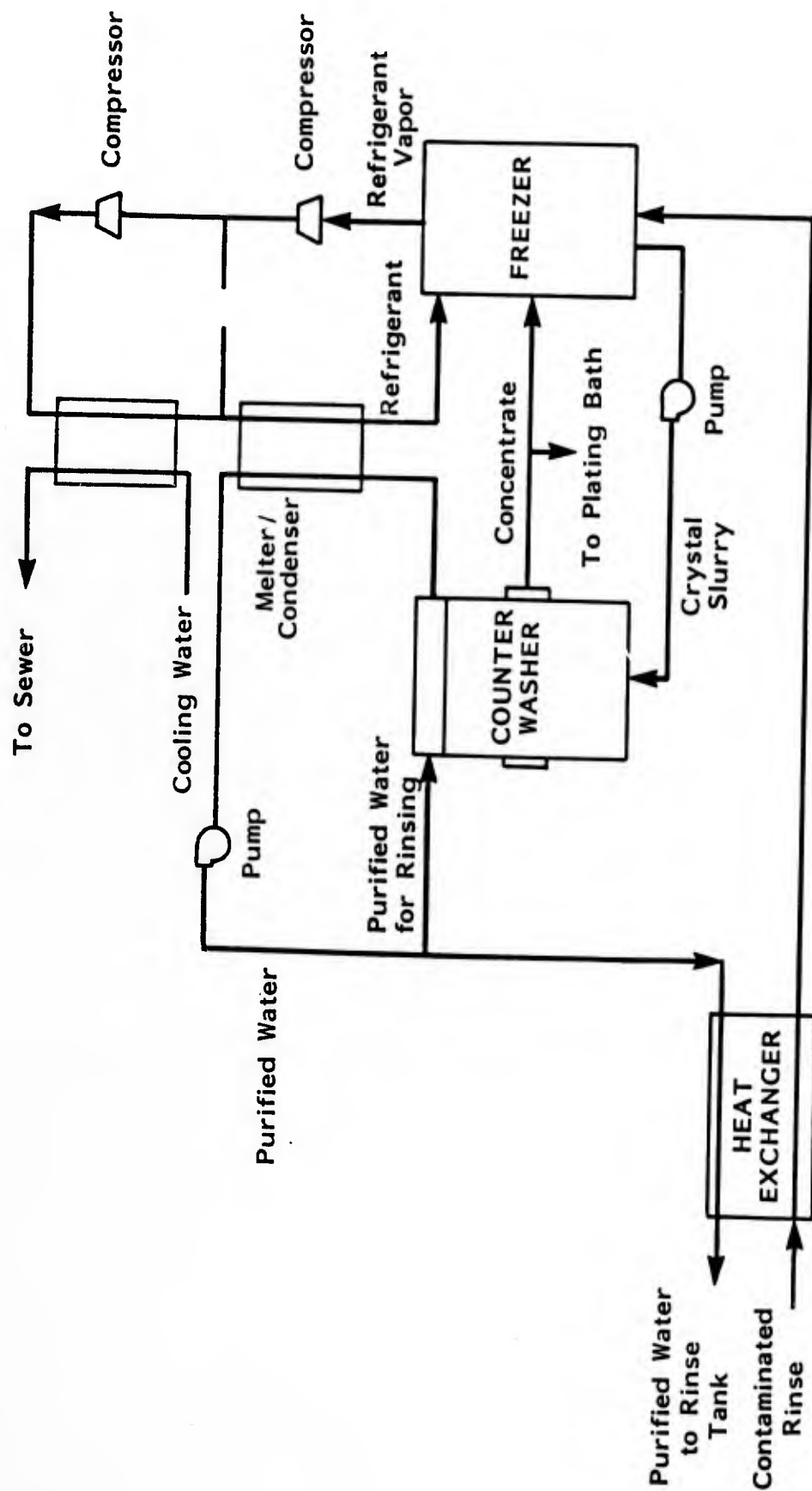

Source: Campbell, R.J., and D.K. Emmerman, "Freezing and Recycling of Plating Rinsewater," *Industrial Waste Engineering*, V. 9, No. 4:39, July 1972.

Figure 41. Freeze Crystallization Process Flow Diagram

Pilot plant results obtained from treatment of plating rinse water are given in Table 33 (Reference 29). Performance of the system is marginal for achieving the effluent limitations required by Federal regulations. Whereas the feedwater concentration shown in the table is high relative to that of many plating facilities, the capability to remove the contaminants to a sufficiently low level may require additional crystal-washing stages or additional treatment steps that would adversely affect the economics of the system.

TABLE 33. PILOT PLANT RESULTS FROM PLATING RinSEWATER

Contaminant	Concentration (mg/l)		% Removal
	Feed Water	Product Water	
Nickel	105	0.44	99.58
Cadmium	105	0.40	99.62
Chromium	110	0.225	99.80
Zinc	100	0.34	99.66
NaCl	30,000	120.00	99.60

NOTE: Capacity of pilot plant = 2,500 gal/d.

SOURCE: Campbell, R.J., and D.K. Emmerman, "Freezing and Recycling of Plating Rinsewater," Industrial Water Engineering, V. 9, N. 2, July 1972, p. 39.

#### 4. Residuals Generated

The generation of residuals will depend upon how the freeze crystallization technology is employed. The most practical application is for recovering metals from single-metal rinse waters and recycling the concentrate to the plating bath. In this application, the purified water can be recycled to the rinse or discharged to the local POTW. As in any closed-loop system, there would be a buildup of impurities in the recycled streams; thus a blowdown would be needed to maintain the impurities at a level that would not harm the plating operations. Treatment of the blowdown stream would result in sludge formation. The amount of sludge formed by treatment of the blowdown, however, would be very small compared with the amount that would be generated if no recovery were practiced and conventional treatment were employed.

Freeze crystallization also can be employed as an end-of-pipe treatment for the concentration of metal contaminants; however, the economics would most likely be unfavorable, because subsequent treatment would be needed to remove the metals from the concentrate. This additional step would result in the generation of a significant quantity of sludge.

## 5. Cost Factors

Table 34 gives the investment costs for 30-gal/min and 100-gal/min end-of-pipe systems. Table 35 gives estimated operating costs for these systems. Tables 36 and 37 give investment and operating costs for a freeze crystallization chromium recovery unit. Both the investment and operating costs are functions of the total water flow rate and, to a limited extent, functions of the initial waste concentrations in the feed stream (Reference 30). Thus, countercurrent rinsing and other water conservation techniques should be used to keep the size and cost of the required treatment system to a minimum.

TABLE 34. ESTIMATED INSTALLED INVESTMENT COSTS<sup>a</sup> FOR TWO-STAGE FREEZE CRYSTALLIZATION SYSTEMS DESIGNED FOR END-OF-PIPE TREATMENT

Unit Capacity (gal/min)	Estimated Installed Investment Cost (\$)
30	605,000
100	2,016,000

<sup>a</sup>Costs do not include those for facilities for further treatment of the resulting concentrate, or for cyanide destruction.

TABLE 35. ESTIMATED VARIABLE OPERATING COSTS<sup>a</sup> FOR END-OF-PIPE TREATMENT

Item	Cost per Unit	Annual Quantity		Annual Cost (\$)	
		30-gal/min Capacity	100-gal/min Capacity	30-gal/min Capacity	100-gal/min Capacity
Labor	\$15/h	4,000 h	8,000 h	60,000	120,000
Maintenance (at 4% of investment)				24,000	81,000
Electricity	\$0.05/kWh	5.4x10 <sup>5</sup> kWh	1.8x10 <sup>6</sup> kWh	27,000	90,000
Cooling water	\$2.00/ 1,000 gal	7.2x10 <sup>6</sup> gal	2.4x10 <sup>7</sup> gal	14,000	48,000
Chemicals				1,000	3,000
Total				126,000	342,000

<sup>a</sup>Costs do not include those incurred for further treatment of the resulting concentrate, or for cyanide destruction.

NOTE: Operating 2 shifts per day, 250 days per year.

TABLE 36. ESTIMATED INSTALLED INVESTMENT COSTS  
FOR TWO-STAGE FREEZE CRYSTALLIZATION  
SYSTEMS FOR CHROMIUM RECOVERY

<u>Unit Capacity (gal/min)</u>	<u>Installed Cost (\$)</u>
10	202,000
34	685,000

TABLE 37. ESTIMATED VARIABLE OPERATING COSTS FOR TWO-STAGE  
CADMIUM RECOVERY SYSTEM

<u>Item</u>	<u>Cost per Unit</u>	<u>Annual Quantity</u>		<u>Annual Cost (\$)</u>	
		<u>10 gal/min Capacity</u>	<u>34 gal/min Capacity</u>	<u>10 gal/min Capacity</u>	<u>34 gal/min Capacity</u>
Labor	\$15/h	2,000 h	4,000 h	30,000	60,000
Maintenance (at 4% of investment)				8,000	27,000
Electricity	\$0.05/kWh	1.8x10 <sup>5</sup> kWh	6.1x10 <sup>5</sup> kWh	9,000	31,000
Cooling Water	\$2.00/ 1,000 gal	2.4x10 <sup>6</sup> gal	8.2x10 <sup>6</sup> gal	5,000	16,000
Chemicals				<u>500</u>	<u>1,000</u>
Total				52,500	135,000

NOTE: Operating two shifts per day, 250 days per year.

## H. INSOLUBLE STARCH XANTHATE

### 1. Summary and State of Technology Development

The insoluble starch xanthate (ISX) process was originally developed at the U.S. Department of Agriculture, Northern Regional Research Center, Peoria, Illinois, under a grant from the Environmental Protection Agency (EPA) (Reference 31). The initial research and development (R&D) efforts demonstrated that relatively inexpensive, chemically cross-linked, natural starch compounds (insoluble in water) can be xanthated to form an anionic polymer capable of removing heavy metal ions from solution by forming insoluble products. Xanthation is the process of forming a salt by replacing the hydrogen attached to the sulfur in xanthic acid with a metal such as sodium or magnesium. The ISX process can be used with conventional treatment steps, or as a precoat on filters to remove metals from the filtrate. The process has been demonstrated to be capable of producing an effluent with very low residual metal concentrations. The resulting ISX-metal sludge is said to dewater to 50-90 percent solids because it is nongelatinous (Reference 32). In addition, claims indicate that metal can be recovered from the ISX-metal sludge by acidification or incineration of the sludge (Reference 33).

Problems with use of this technology stemmed primarily from a lack of commercially available ISX, and the limited stability of ISX in liquid form. Even in solid form, however, ISX degrades relatively fast and loses its ability to remove metal ions from solution (Reference 32).

After internal product R&D, Pollution Technology Systems, Inc., of Garland, Texas, announced formula changes that allow for mass production of ISX with optimum heavy metal uptake capacity, solving many of the shelf life stability problems. Pollution Technology Systems first made ISX commercially available in January of 1980, and the active customer list has grown considerably. To date, approximately 100 electroplating and printed circuit board manufacturing facilities use the process (Reference 34).

### 2. Process Description

Used in conjunction with conventional treatment, ISX powder is slurried with water, then metered into the treatment system before or following pH adjustment. It is effective over a pH range of 3 to 11, but optimum performance is achieved at pH 9. ISX acts as an ion exchange liquid, bonding with heavy metal ions in exchange for sodium and magnesium ions, which it releases to the solution. The ISX-metal combination is insoluble and settles by gravity separation (Reference 34). Dewatering is generally performed on a filter precoated with diatomaceous earth. Because the ISX-metal sludge is nongelatinous, it is said to be dewaterable to 30-90 percent solids by filtration or centrifugation (Reference 32).

When employed as a polishing technology, ISX can be used as a precoat on a rotary drum vacuum filter to remove remaining heavy metal ions from solution as the sludge is dewatered. This technique is illustrated by an application at an electroplating facility in Connecticut (Figure 42).

At the Connecticut facility, copper, chrome, and nickel plating are performed. All the plating processes have individual dead rinses followed by two counterflow rinses. The wastewaters from the rinses are segregated to allow for cyanide oxidation using hypochlorite, and the reduction of hexavalent chromium using metabisulfite. The combined flow of all rinses, totaling 110 gal/min, flows to a common sump for pH neutralization. In the sump the pH is adjusted to 9.0 using caustic. The neutralized wastewater is then pumped to a 12,000-gallon holding tank. The sludge slurry is continuously pumped from the bottom of the holding tank to a precoated filter for dewatering of the sludge and removal of the metal ions remaining in solution (Reference 31).

ISX acts as an ion exchange medium, removing heavy metal ions and replacing them with sodium and magnesium ions. The filtrate is recirculated to the holding tank and 90 percent of the decant from the holding tank is recirculated to the rinse tanks. The ISX precoat is generally changed once a week (Reference 31).

As illustrated by this system, very little equipment is required beyond that needed for a conventional treatment system.

### 3. Operation and Maintenance Requirements and System Performance

For an ISX system used in conjunction with conventional treatment steps, routine operational and maintenance tasks would involve maintaining an inventory of properly stored ISX, preparing the ISX slurry daily, and calibration and maintenance of the ISX metering system. The remaining requirements would be the same as for conventional treatment.

ISX, as purchased from Pollution Technology Systems, is a yellow powder with a light pungent odor (Reference 36). When the powder particles are dry, their size is 20 $\mu$ m; in aqueous solution they swell so that 90 percent of them are larger than 40 $\mu$ m.

Pollution Technology Systems, sells ISX in 25- and 250-pound net units. Approximate prices for one unit are \$4.20/lb and \$2.45/lb, respectively. The ISX is shipped under refrigeration and must be stored under refrigeration at the plant to maintain a reasonable shelf life. ISX has a shelf life of approximately 6 months when stored at 45°F. If the powder is stored at 70°F, approximately 3 percent of the xanthate sulfur will be reduced in 7 days, decreasing the effectiveness of the ISX (Reference 36).

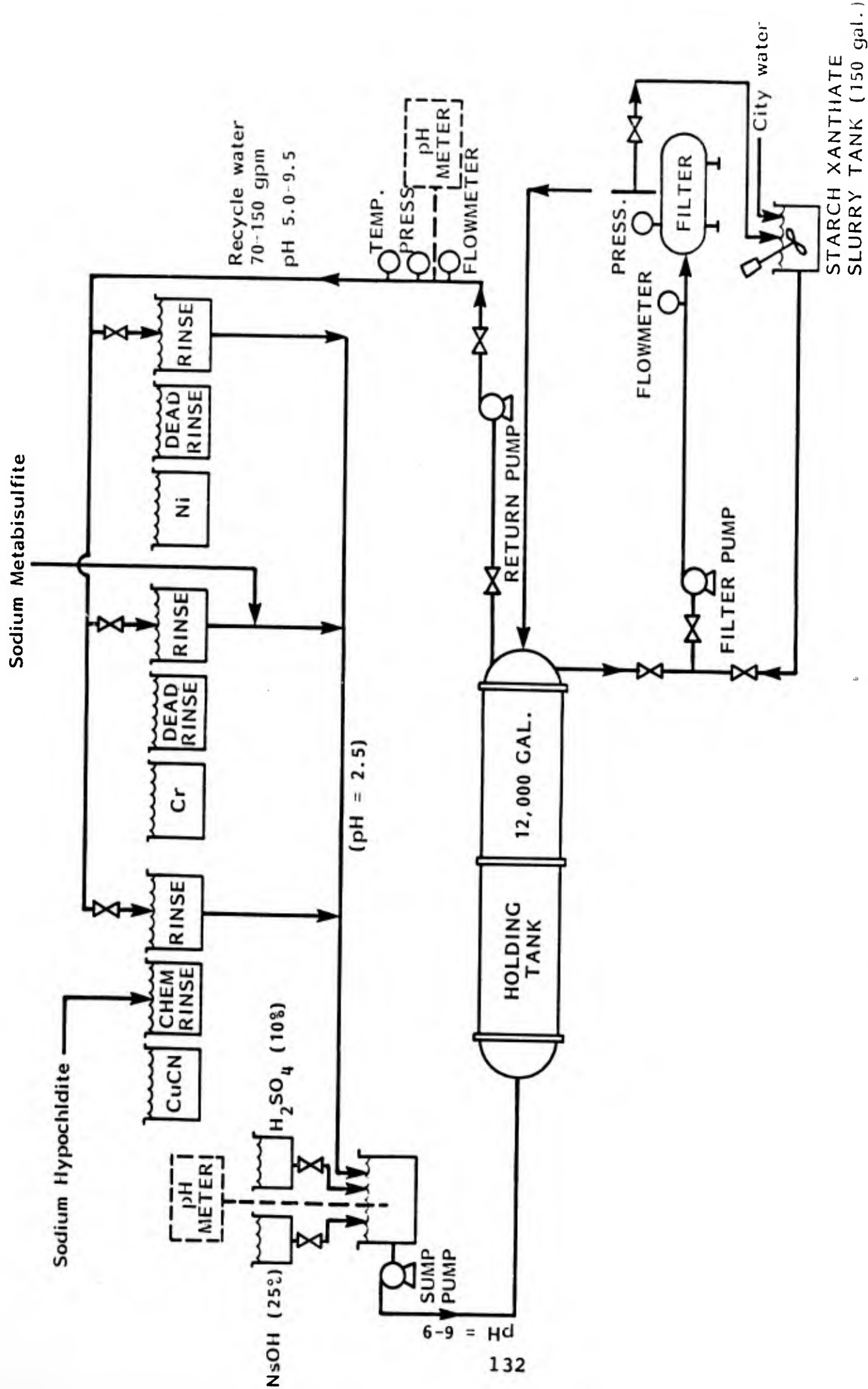

Figure 42. Use of ISX as a Filter Precoat

Because moisture content of the ISX is critical to its stability, the storage area must be dry. ISX samples decompose more quickly in direct light and, if left in the open, will absorb water and decompose. Decomposed ISX samples will exhibit a pink-orange color and have a strong pungent odor (Reference 33).

Daily preparation of the ISX slurry would involve mixing predetermined amounts of ISX powder and water in a chemical feed tank. The slurry should be prepared at the ratio of approximately 2 pounds of ISX per gallon of water.

ISX dosage is determined from laboratory testing. Calibration of the metering system involves monitoring the flow rate and adjusting the control system to deliver slurry in the required amount. The average capacity of ISX is in the range of 1.1 to 1.5 milliequivalents of metal ion per gram ISX. Thus, for a divalent nickel ion, one gram of ISX would remove 32 to 43 mg of nickel ions from solution (Reference 32). Maintenance of this system involves periodic flushing of the lines to prevent build-up of ISX and restriction of the lines, and periodic checks of the metering system calibration.

Laboratory tests indicate that ISX is capable of approaching a 99-percent metal removal effectiveness when used in conjunction with conventional treatment steps. The results of laboratory tests using single-metal solutions and mixed-metal solutions are given in Tables 38 and 39.

Table 40 gives case study results from an electroplating facility using ISX as a filter precoat to polish the effluent.

#### 4. Residuals Generated

In conjunction with conventional treatment steps, using ISX as an additional treatment reagent will cause some increase in the weight of solids generated during treatment. In addition, the increased metal removal efficiency of the system means that metals that would otherwise be present in the effluent will be present in the sludge. This increase in weight of the solids may not increase disposal costs, however, because the ISX-metal sludge is said to dewater more easily than ordinary hydroxide sludge (Reference 37). A potential, therefore, exists for reducing both the weight and the volume of the sludge to be disposed of. Laboratory tests should be conducted with actual wastewaters to determine the total effect of the technology on the sludge at a particular site.

In addition, disposal costs may be reduced through use of the ISX technology if the resulting sludge can be delisted and disposed of in an ordinary industrial waste landfill rather than in a hazardous waste landfill. It is reported that, as determined by the Extraction Procedure (EP) test, the sludge resulting from ISX treatment of metal-laden wastewaters is nonhazardous (Reference 38).

TABLE 38. REMOVAL OF HEAVY METAL CATIONS FROM SINGLE METAL SOLUTIONS USING ISX<sup>a</sup>

Metal	Initial Concentration (mg/l)	Weight of ISX Used (g)	Metal Concentration in Effluent (mg/l)
AU <sup>+1</sup>	53.94	0.32	0.016
AU <sup>+3</sup>	30.00	0.50	0.010
Cd <sup>+2</sup>	56.20	0.64	0.012
Co <sup>+2</sup>	29.48	0.64	0.090
Cr <sup>+3</sup>	26.00	0.64	0.024
Cu <sup>+2</sup>	31.77	0.32	0.008
Fe <sup>+2</sup>	27.92	0.32	0.015
Hg <sup>+2</sup>	100.00	0.64	0.001
Mn <sup>+2</sup>	27.47	0.64	0.015
Ni <sup>+2</sup>	29.35	0.64	0.160
Pb <sup>+2</sup>	103.60	0.64	0.035
Zn <sup>+2</sup>	32.69	0.32	0.029

<sup>a</sup>Synthetic single-metal process wastewaters with the indicated initial concentrations were treated with the indicated amount of ISX at an initial pH of 3.7. After thorough mixing, the pH was adjusted to 9.0 and the solution was filtered.

SOURCE: Pollution Technology Systems, Inc., "Insoluble Starch Xanthate", Bulletin PTS 1-83, Garland, Texas.

TABLE 39. REMOVAL OF HEAVY METAL CATIONS FROM MIXED METAL SOLUTIONS USING ISX<sup>a</sup>

Metal	Initial Concentration (mg/l)	Metal Concentration in Effluent (mg/l)
Cd <sup>+2</sup>	5.62	0.001
Co <sup>+2</sup>	2.95	0.010
Cr <sup>+3</sup>	2.60	0.026
Cu <sup>+2</sup>	3.18	0.005
Fe <sup>+2</sup>	2.79	0.001
Hg <sup>+2</sup>	10.00	0.0007
Mn <sup>+2</sup>	2.75	0.010
Ni <sup>+2</sup>	2.93	0.050
Pb <sup>+2</sup>	10.36	0.031

<sup>a</sup>Synthetic process wastewaters with the indicated metals were treated with 320 g of ISX at an initial pH of 4.6. After thorough mixing, the pH was adjusted to 8.9 and the solution was filtered.

SOURCE: Pollution Technology Systems, Inc., "Insoluble Starch Xanthate", Bulletin PTS 1-83, Garland, Texas.

TABLE 40. METAL REMOVAL RESULTS USING ISX AS A FILTER PRECOAT

Metal	Initial Concentration <sup>a</sup> mg/l	ISX Treated Conc., mg/l
Cr <sup>+3</sup>	0.8	0.02
Cu <sup>+2</sup>	7.0	0.02
Ni <sup>+2</sup>	2.5	0.10

<sup>a</sup>Before ISX treatment.

SOURCE: Wing, R. E., and D. W. McFeeters, Insoluble Starch Xanthate Aids the Metal Finishing Industry in Meeting Heavy Metal Discharge Criteria, Northern Regional Research Center, Agricultural Research Service, U.S. Department of Agriculture, Peoria, Illinois, p. 11.

Sludge disposal costs associated with the use of ISX as a filter precoat are likely to be greater than conventional treatment disposal cost since the filter precoat will add to the weight and volume of sludge.

## 5. Cost Factors

Because the cost of ISX for metal removal is in the range of \$70 per pound of metal, it is only applicable to polishing of waste streams previously treated by conventional processes or for treatment of highly dilute waste streams. The cost of the mechanical equipment depends on the method chosen for bringing the wastewater in contact with the ISX.

A filter using a precoat of diatomaceous earth and ISX has the advantage of achieving the reagent/wastewater contact and solids removal in a single process unit. Minimum installed cost is approximately \$50,000 for a precoat filter with 40 ft<sup>2</sup> of filter area. This size unit should handle waste flows in the range of 20 to 40 gal/min. Larger units sized for flows in the range of 100 gal/min would cost approximately \$80,000 installed.

### I. SACRIFICIAL IRON ANODES

#### 1. Summary and State of Technology Development

The sacrificial iron anode process involves an electrochemical reaction in which an electrical current is applied to consumable iron anodes. The anodes release ferrous ions into solution; these ions react with hexavalent chromium (Cr<sup>+6</sup>) and reduce it to the trivalent state (Cr<sup>+3</sup>) (Reference 39).

Two equipment types are currently marketed. The first commercial product houses the anodes in a stirred reactor and achieves intimate contact between the wastewater and the anodes. The second commercial unit houses the anodes in a separate chamber where a concentrate of ferrous ions is generated. The concentrate is added to the wastewater in a stirred-tank reactor. Currently there are approximately 30 of these units in commercial operation. Several are used in electroplating plants (Reference 40). The primary advantage is that the reduction reactor proceeds rapidly at neutral pH, eliminating the need to acidify the chromate wastewater.

The electroplating industry has not made more use of this technology because electroplating wastewater regulations require that the trivalent chromium be removed from solution. This step is generally accomplished by treatment with caustic or lime to produce insoluble chromium hydroxide. The use of sacrificial iron anodes generates three ferrous ions for every hexavalent chromium ion that is reduced. As a result, when the solution is treated with caustic or lime, insoluble ferric hydroxides are produced which increase the quantity of sludge produced. Owing to high sludge disposal costs, the sacrificial iron anode process is seldom employed for chromium reduction at electroplating facilities.

## 2. Process Description

Electrochemical reduction units (Figure 43) are being marketed to compete with chromium reduction systems that use chemical reducing compounds. The process uses consumable iron electrodes and an electrical current to generate ferrous ions that react with hexavalent chromium to produce trivalent chromium as follows:

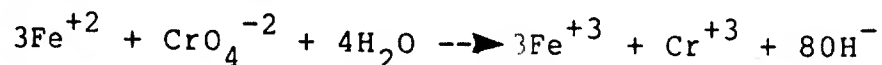

The reaction occurs rapidly and requires minimum retention time. Hexavalent chromium in the effluent can be reduced to less than 0.05 ppm. Because hydroxide ions are generated, the pH of the stream usually increases from 0.5 to 1 pH unit. If the pH of the chromium wastewater is maintained between 6 and 9, the ferric and trivalent chromium ions will precipitate as hydroxides. At lower pH values, the chromium wastewater is treated in the neutralizer. Because ferrous ions are introduced into the wastewater, additional solids will be generated.

The process is effective within acidic to slightly alkaline pH ranges. The effectiveness eliminates the necessity to acidify chromate wastewaters before reduction as in conventional sulfur compound reduction.

## 3. Operation and Maintenance Requirements and System Performance

Routine operating requirements focus on washing the electrode surfaces for 10-15 minutes daily, and replacing the electrodes, normally every two weeks (Reference 41). Other operating or maintenance requirements simply entail ensuring that the mechanical components of the system perform normally. This system requires less operator attention than needed for conventional sulfur dioxide or sodium metabisulfite systems.

The sacrificial iron anode system process, if properly designed, has been demonstrated to be capable of removing hexavalent chromium from wastewater to less than 0.05 mg/l.

## 4. Residuals Generated

The major disadvantage of the iron anode reduction system is that it results in an increased quantity of sludge; the additional sludge results from the precipitated iron hydroxide. For treatment of wastewater with dilute chromate concentrations, however, the additional sludge generated may be less than that associated with conventional reduction with sulfur compounds. In conventional reduction the need to acidify the wastewater and the subsequent neutralization adds considerable non-heavy-metal precipitants to the solid waste.

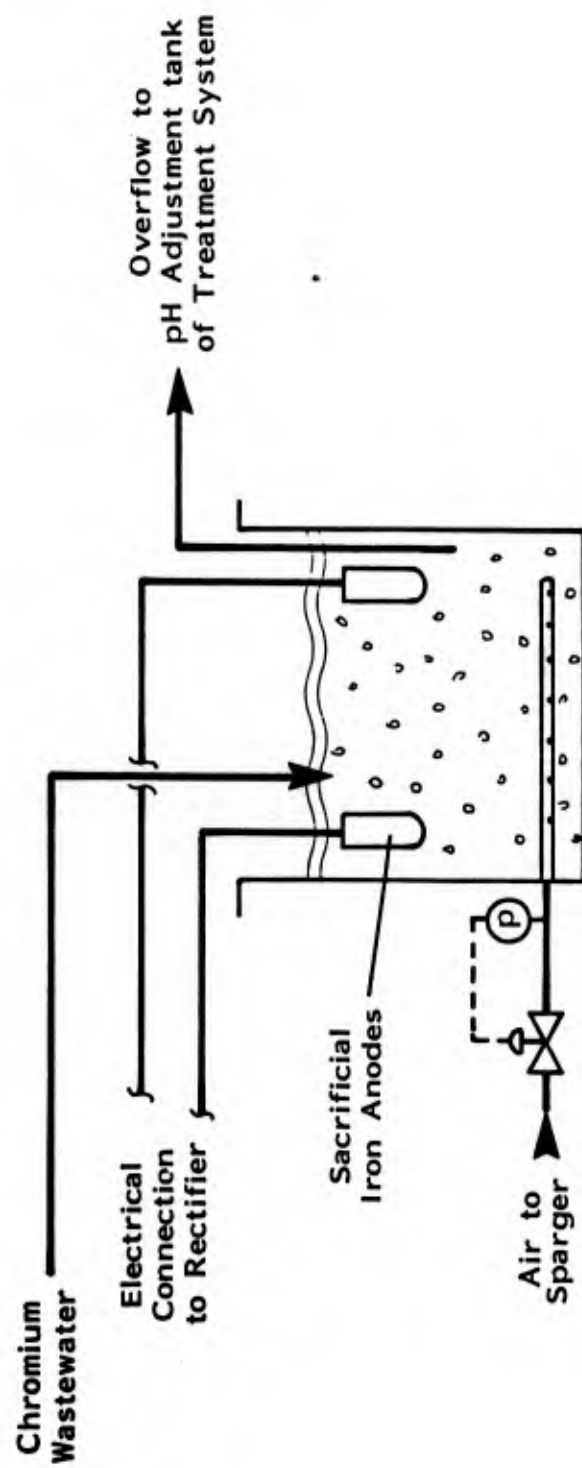

Figure 43. Sacrificial Iron Anode Process

## 5. Cost Factors

The investment cost and size of a sacrificial iron anode reduction system is a function of the mass flow rate of the hexavalent chromium entering the unit. Figure 44 gives the installed costs for an electrochemical reduction system. Given a volumetric flow rate of 40 gal/min and a hexavalent chromium concentration of 20 ppm, the total installed cost for the electrochemical unit is \$54,000.

Operating costs for the process are primarily for electricity and replacement of the iron anodes. Costs are typically lower for this process than for conventional reduction to treat dilute wastewaters containing less than 20 ppm of chromate.

## J. ULTRAFILTRATION AND MICROFILTRATION

### 1. Summary and State of Technology Development

For a given chemical precipitation process, the efficiency of metal removal depends greatly on the use of a suitable solid/liquid separation system. The types of separation systems in use for conventional treatment involve gravity separation (for example, by clarifiers) or filtration (for example, by multimedia or sand filters used for polishing). An alternative to conventional separation systems is ultrafiltration or microfiltration. Ultrafiltration and microfiltration use a porous structure to filter particulates from a liquid phase. The technology can be applied for primary separation of solids or as a polishing technique for further removal of the suspended solids from a clarifier effluent. The most promising application for plating wastewater treatment is at locations where effluent limits are very stringent--below the technical capabilities of conventional separation techniques. The colloidal particles that escape conventional clarifiers and sand filters could be removed by either ultrafiltration or microfiltration.

Ultrafiltration has been used as a pollution control technology for more than 10 years. Until recently, applications in the metal finishing industry were limited to oil-water separation and electrocoat paint rejuvenation. With new advances in membranes and system design, commercial units are now available for use with metal hydroxide precipitation systems.

Microfiltration is a relatively new technology that has had only limited application to metal-bearing wastewaters. An EPA research and development study investigated the application of microfiltration to battery manufacturing wastewaters. Since that study, a number of firms are marketing the technology to a variety of industries, including the metal finishing industry.

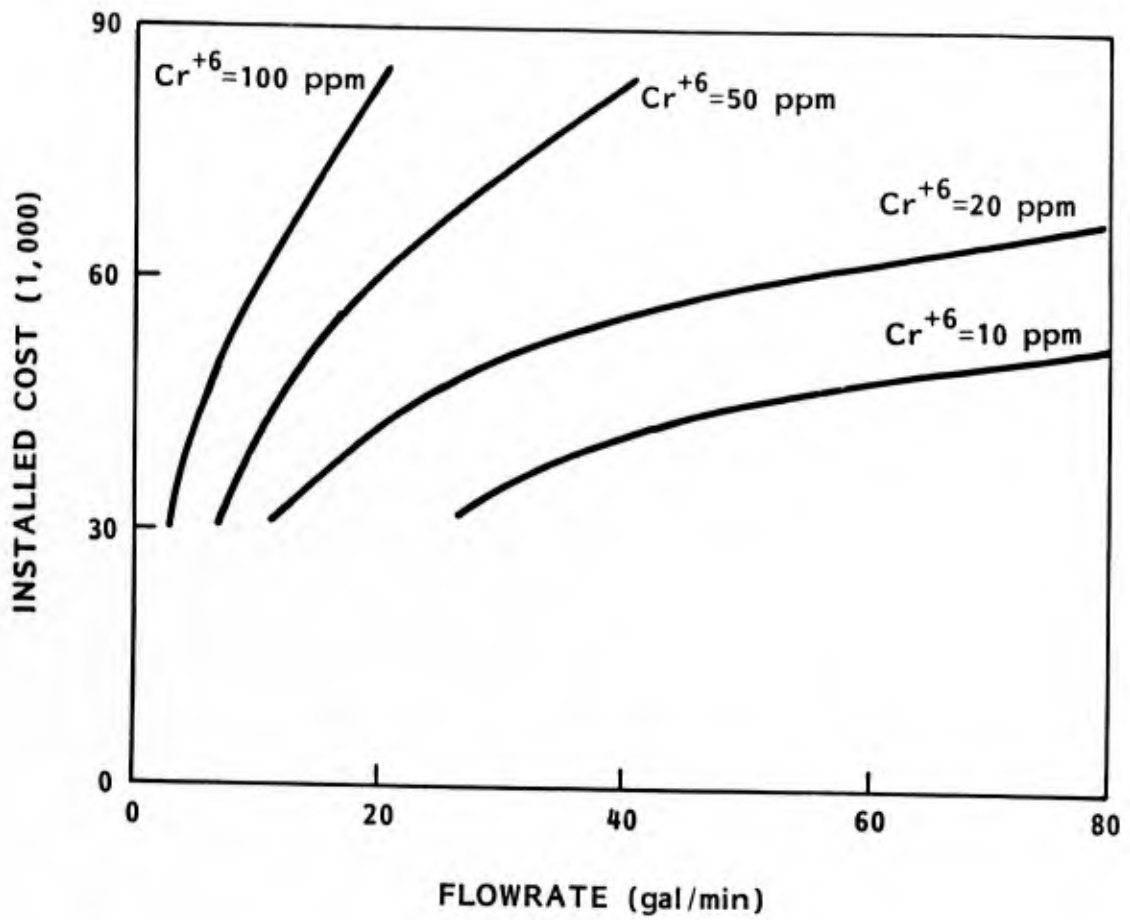

Figure 44. Installation Cost of an Electrochemical Chromium Reduction unit

## 2. Process Description

Wastewater containing particulate solids is passed through a tubular or flat channel that has porous walls. The pore size may be 0.001 to 5  $\mu\text{m}$  diameter, depending on the specific application. Pore sizes in the 0.001- to 0.01- $\mu\text{m}$  range are used for ultrafiltration membranes. These pores are an order of magnitude larger in diameter than those found in reverse osmosis membranes. Colloidal particles can be removed by ultrafiltration, but the low fluxes (200 to 600 gal/day-ft<sup>2</sup>) make this technology expensive for removal of larger particulates. At least one U.S. company, Romicon, supplies ultrafiltration systems for removal of solid particles.

The next step up in pore size is microporous membrane filtration with pore diameters in the 0.1 $\mu\text{m}$  range. In this technology, emphasis is on high sludge solids (15-20 percent) and specialized chemical precipitation systems. Memtek has developed systems based on membranes with these pore sizes. The systems employ a reduction-based process that produces a low volume of solids. One application removes copper in chelated copper printed-circuit-board rinse waters as elemental copper in suspension.

At the high end of the pore diameter scale is microfiltration using porous plastic tubing (not membranes). The pore diameters are 1 to 5 $\mu\text{m}$ , and fluxes of 1,000 gal/day-ft<sup>2</sup> are attained with pressures of 30-50 lb/in<sup>2</sup> gauge. Turbulent flow is a must for this and the other two types of systems. The solids must not build up on the porous surface or the flux is sharply reduced. The use of microfiltration was developed by Hydronautics, Inc., and is now marketed by Neptune Microfloc under the Hydroperm tradename.

## 3. Operation and Maintenance Demands and System Performance

Operation and maintenance of ultrafiltration and microfiltration systems may require specialized training. Even though the systems do not operate at high pressure, inlet and outlet pressures and effluent flow must be monitored to ensure that the system is operating properly. Pressure loss can indicate leaks and interruption of permeate flow can indicate blockage of the pores. All three systems require occasional chemical or physical cleaning. Frequency depends on the specific wastewater, and especially on the content of organics. The skill level for operators will depend on how extensively the system is automated.

At the one commercial installation of ultrafiltration, a Romicon unit has been used as a polishing filter for porcelain enameling wastewater. The mill room wastewater is fed to a sump and the overflow from the sump is combined with the metal preparation wastewater in a 5,000-gallon holding tank. Mill room wastewater contains mostly solid frit particles; the metal

preparation stream contains mainly dissolved nickel and iron. The pH is raised to 8.5-10 with sodium hydroxide (caustic) in the holding tank. The effluent from the holding tank is pumped to a 2,500-gallon working tank, from which the effluent is pumped into the ultrafiltration unit in a batch treatment operation. A bag filter is inserted between the pump and the ultrafiltration modules. The concentrate from the ultrafiltration unit containing the suspended solids is returned to the working tank. After cycling is complete (that is, volume of working tank is reduced to the desired level), the ultrafiltration unit is turned off. Permeate rate drops to about one-third<sup>2</sup> of its original value at the end of the batch run. The 15 ft<sup>2</sup> of membrane area produces 6 gal/min at the beginning of the run. Analysis of the permeate reveals TSS <1 mg/l; Ni = 0.02 to 2.3 mg/l; Fe = 0.22 to 46 mg/l. The higher values of nickel and iron were obtained with a pH of 9.4 in the permeate. Although the performance meets the requirements of the indirect discharger operating this system, the wide range of concentrations in the permeate suggests the need for further evaluation of the performance of this unit.

#### 4. Residuals Generated

The volume of residuals generated depends on the particular system used and the type of wastewater treated. The ultrafiltration system used at the porcelain enameling plant produces about 1 gallon of concentrated sludge for each 10 gallons of wastewater treated. Membrane microfiltration systems are designed to produce up to 20 percent solids without filter presses. Manufacturer's literature claims that 1 gallon of sludge for each 1,000 gallons of wastewater treated as typical. Such systems are designed for each specific wastewater stream and would necessitate segregation of the streams according to the selected treatment scheme. If the streams are segregated throughout the treatment, different solids concentrations would result, depending on the specific metal being removed and the chemical treatment selected.

Organic components of metal finishing baths (that is, antifoamers and surfactants) foul the membranes. An in-place cleaning system is used to flush the tubes on a regular schedule. The used cleaning solution is a residual also requiring disposal. For the Memtek system, cleaning requires 2 hours and is normally accomplished once a week, according to manufacturer's literature.

For the operating ultrafiltration system, a cleaning tank is included with the unit. A proprietary soap solution is added to water in the cleaning tank and the solution is recirculated through the system for 1/2 to 3/4 hour. The cleaning can be automatic or manual. A fresh soap solution is used for each cleaning. The used cleaning solution is added to the holding tank, and does not add to the volume of residuals to be contract-hauled.

The porous tubing microfilter system produces a concentrated residual stream bearing about 1-1/2 to 3 percent solids. Thus the volume of the residuals stream is about 10 times the volume obtained with microporous membranes for the same wastewater.

## 5. Cost Factors

All three of these filtration technologies are expected to have greater capital costs per unit of capacity than more traditional systems, such as multimedia filtration. Therefore, significant savings in cost of a system can be realized by segregation of wastewaters for specific end-of-pipe treatment and by use of water conservation measures. Reducing wastewater flows will reduce equipment costs as well as costs for treatment chemicals costs.

The ultrafiltration system in use at the porcelain enameling plant is an HF6 modular by Romicon. The skid-mounted unit has a 7-1/2 horsepower motor to circulate 180 gal/min through the unit at 25 lb/in<sup>2</sup> gauge. The cost of the unit, which can treat 2,000 gallons in an 8-hour period, is about \$35,000. The use of caustic instead of lime increases precipitation costs but reduces the volume of solids generated and hauled.

## K. FERROUS SULFATE REDUCTION

### 1. Summary and State of Technology Development

The use of ferrous sulfate ( $\text{FeSO}_4$ ) to reduce hexavalent chromium to the trivalent state in an acidic solution has been proven reliable for meeting pollution control guidelines. An abundant, inexpensive supply of ferrous sulfate, which is a waste product from the sulfuric acid pickling of steel, made it the reagent of choice for many facilities. In terms of reaction rate and control strategy, the process is similar to the conventional approach of using a sulfur-based reducing compound. Ferrous sulfate reduction also requires the pH of the chromate waste stream to be controlled between 2.0 and 3.0 to achieve a rapid reduction reaction rate. A disadvantage of the process is that 3 equivalents (eq) of ferrous ions are required per equivalent of chromate ion; the ferrous ions (plus 2 valence) are converted to ferric ions (plus 3 valence) in the oxidation/reduction reaction. In the subsequent neutralization step, the ferric ions precipitate as hydroxides along with the chromium. Consequently, the volume of sludge produced is significantly greater than that associated with sulfur-compound-based reduction processes.

A recently developed process using ferrous sulfate to reduce chromate in an alkaline solution showed some promising results in pilot evaluations. The main advantage of this process over conventional reduction is that the wastewater pH

need not be reduced to between 2.0 and 3.0 to achieve fast and complete reduction. In this process, the pH is maintained between 7.0 and 10.0. Consequently, the reduction can be accomplished in the same reactor as neutralization/precipitation. This approach represents a saving in acid and base reagents and requires less process equipment than conventional reduction.

Alkaline reduction still requires three ferrous ions per chromate ion, and the process will generate significantly greater sludge volumes per equivalent of chromium than conventional process. For treatment of dilute chromate wastes, however, the amount of sludge generated will not be a significant concern. One deficiency revealed during the pilot evaluation is lack of a fast, accurate method of controlling the ferrous sulfate additions to the wastewater. The pilot study used an in-line colormetric instrument to determine chromate concentration. This instrument had significant lag time (1 minute) and this type of control instrument is not widely used in industry.

## 2. Process Description

The use of ferrous sulfate for acid reduction of chromate is essentially identical to conventional sulfur-based systems in terms of process equipment. The only significant difference is that sodium metabisulfite is replaced with a solution of ferrous sulfate. Figure 45 shows the necessary equipment.

The hexavalent chromium is reduced to the trivalent form by reaction with ferrous ions as follows:

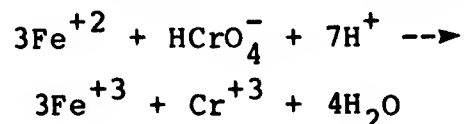

The trivalent ferric and chromium ions are precipitated as hydroxides in the neutralizer.

Sulfuric acid is added to the reduction unit to maintain the pH between 2.0 and 3.0 for a rapid reduction rate. Ferrous sulfate is added to maintain the ORP control set point. As shown in Figure 46, the completion of the reduction reaction has a distinct end point in an acidic environment.

The use of alkaline ferrous ion reduction of chromate has been studied through grants from the U.S. Air Force to Arizona State University (Reference 42). The Air Force felt that a process that reduced chromate ions at a pH near that at which chromium is precipitated as a hydroxide would be advantageous in avoiding the acidification and subsequent neutralization associated with conventional techniques.

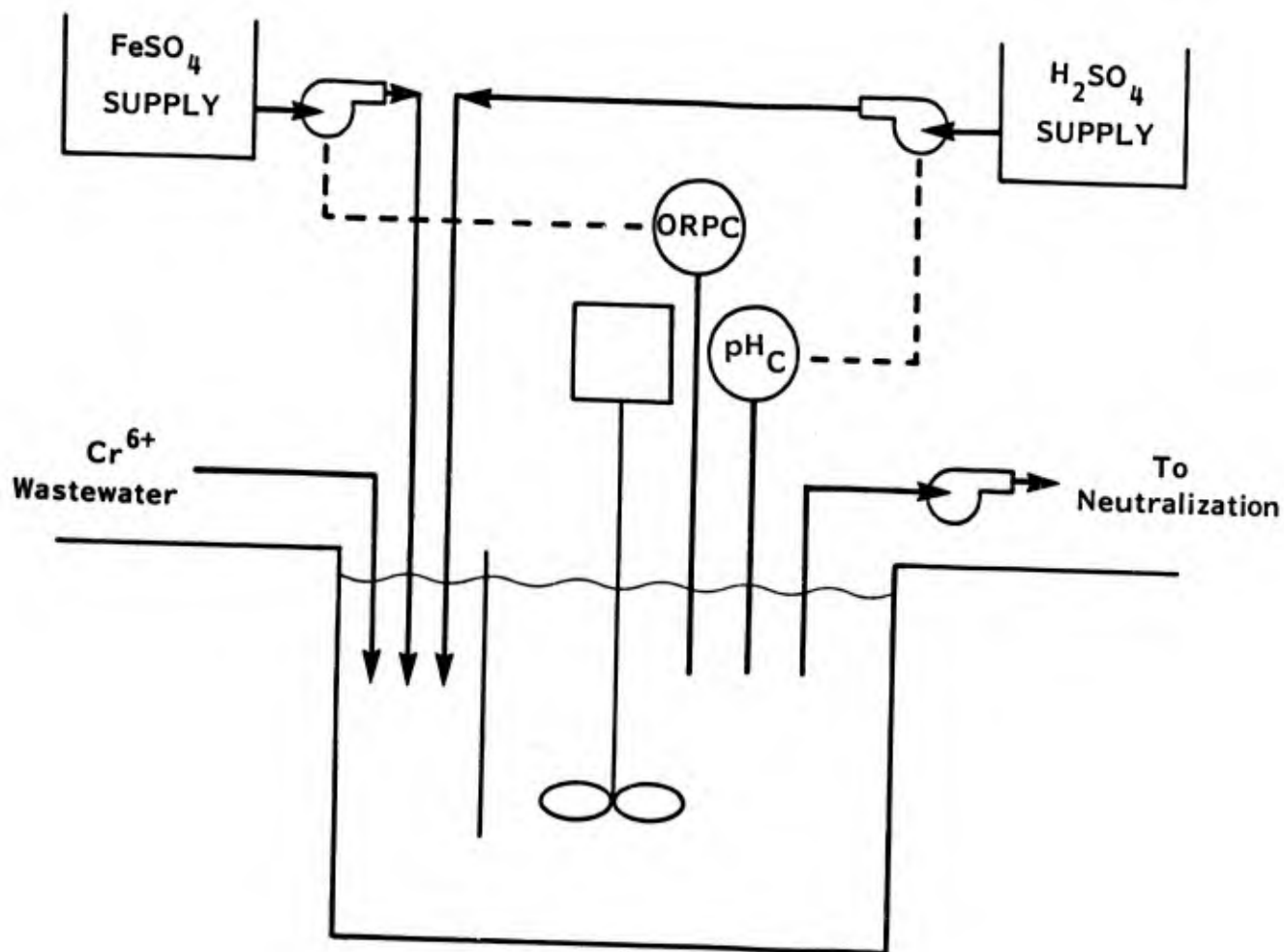

Figure 45. Chromium Reduction Treatment Unit

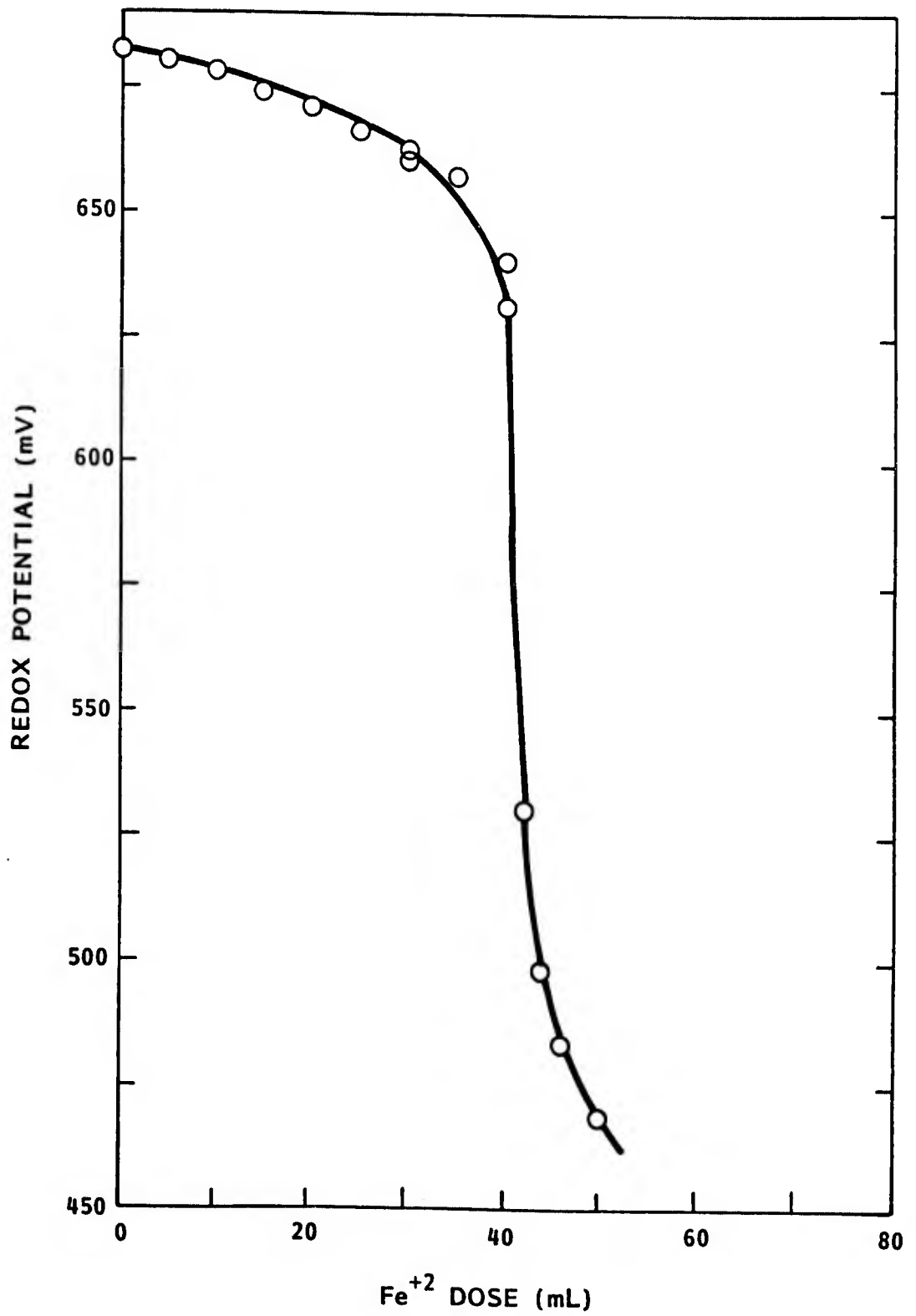

Figure 46. Redox Potential Control Set Point for FeSO<sub>4</sub> Chromium Reduction

The pilot evaluation showed encouraging results in achieving a rapid reduction of chromate at pH levels between 8.0 and 10.0 with only slightly greater than stoichiometric doses of ferrous sulfate. The resulting precipitants could be separated from the wastewater by flocculation and clarification/filtration.

The only shortcoming of the pilot process evaluated in the study was the control method for adding the ferrous sulfate. An on-line colorimetric analyzer was used to measure the chromate concentration in the mixing tank. This instrument had a lag time approaching 1 minute, which is considerable for an in-line control loop. Methods of compensating for this limitation should be evaluated in any full scale application.

### 3. Operation and Maintenance Demands and System Performance

Operation and maintenance of either the acid or alkaline reduction systems require no skills beyond those normally associated with wastewater treatment operator training.

System performance for both acid and alkaline processes is adequate to meet pollution control guidelines. Residual hexavalent chromium concentrations of 0.05 ppm were consistently achieved for both processes.

### 4. Residuals Generated

The use of ferrous ions for chromate reduction results in 3 eq of ferric ions per equivalent of chromate ion treated. Consequently, 3 eq of ferric hydroxide are precipitated for each equivalent of chromic hydroxide removed. The excess sludge produced has limited the application of the acidic reduction process to waste streams containing dilute concentrations of hexavalent chromium.

The alkaline reduction process may produce less sludge than conventional sulfur reduction because it is not necessary to neutralize the chromium reduction process effluent. Lime added to neutralize before discharge will add significantly to the mass of solid waste generated.

### 5. Cost Factors

The cost for an acid-based ferrous sulfate reduction unit should be identical to the cost given for the sulfide precipitation process. Cost was \$19,000 for a 10 gal/min unit and \$28,000 for a 33 gal/min unit. Reagent costs for ferrous sulfate should be slightly lower than for sodium metabisulfite, but this saving should not be significant.

The advantage of the alkaline process approach is that a chromium reduction system need not be purchased. Reduction would be accomplished in the same stirred-tank reactor used for neutralization.

## L. INTERGRATED TREATMENT

### 1. Summary and State of Technology Development

Integrated treatment has been used for a number of years for pollution control, primarily to treat specific pollutants that required pretreatment before being discharged to the common wastewater treatment system. EPA funded an early investigation of the process, the results of which were published in 1973.

The term integrated treatment is used literally, in that the pollutant treatment is integrated into the actual plating sequence. The rinse station immediately following a plating bath contains a chemical rinse. The plated parts emerge from the plating bath and are rinsed in the chemical solution. The plating bath film dissipates into solution and the pollutants are chemically neutralized. The parts emerge from the integrated treatment rinse and are rinsed with water in the conventional manner. The rinse water, however, does not now contain the pollutants that were present in the plating bath.

Integrated treatment is used primarily for cyanide oxidation and chromium reduction because wastewater containing these pollutants would otherwise require pretreatment. With integrated treatment, the rinse water from these plating processes can be sent directly to the neutralization/precipitation system.

That integrated treatment is a part of the plating process is the major deterrent to its application. Although such treatment may be cost effective, because it adds another variable to plating quality, its use is resisted.

### 2. Process Description

Figure 47 shows the components of a typical integrated treatment process, including:

- Chemical rinse in the plating line
- Recirculation pump
- Treatment chemical reservoir

One treatment reservoir/recirculation pump can serve several plating baths that contain the same pollutant that the chemical rinse is designed to treat. The treatment reservoir should be designed to allow any precipitants to settle and be

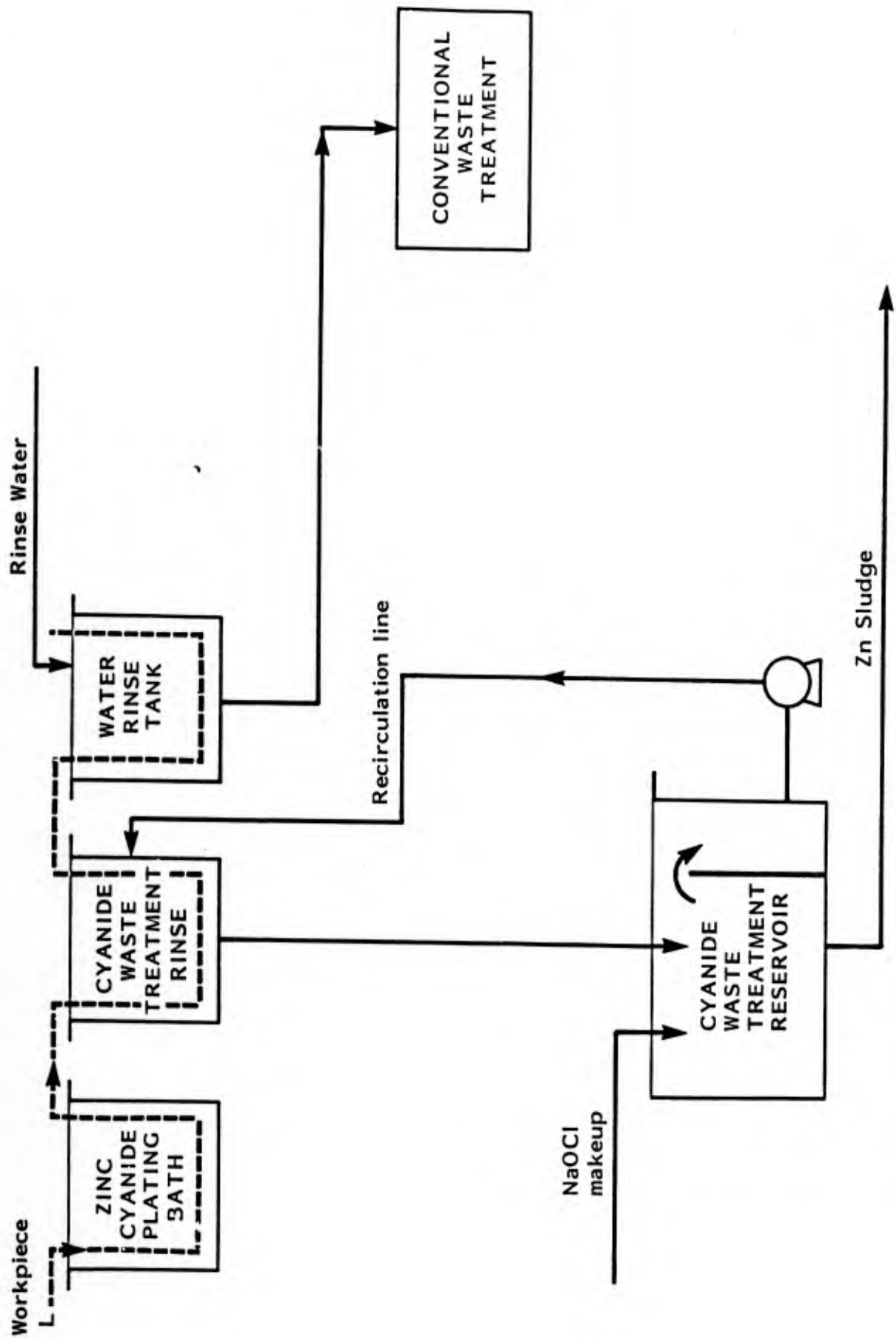

Figure 47. Integrated Treatment for Cyanide Plating Rinse Water

removed from the recirculated chemical rinse. Consequently, sludge that accumulates in the settling chamber must be removed periodically.

Chemical additions to the treatment reservoir can be made daily. Relatively simple tests can be used to determine the amount of chemicals required.

The main advantage of integrated treatment is that it eliminates the need to install sophisticated wastewater treatment systems. Particularly for manual plating operations, the cost to install an integrated system should be minimal. For automated plating operations, the plating line must have rinse stations that can be dedicated to chemical rinsing in order to make integrated treatment feasible. Another major advantage is that integrated treatment requires no automatic controls because an excess of treatment reagents is maintained in the chemical rinse.

The primary application of integrated treatment is for cyanide oxidation. Integrated treatment eliminates the need to purchase an expensive automated cyanide oxidation system.

The process has also been demonstrated for chromium reduction; the multiple origins of chromate wastes in a plating shop tend to make this application less attractive.

The disadvantages of integrated treatment include:

- Plating quality may suffer ill effects.
- Provisions must be made to treat floor spills of plating solution.
- Additional rinse tanks may be needed.
- The metal finisher must dedicate his attention to waste treatment, because the process is part of the plating operation.

The concern about plating quality stems primarily from the lack of data defining the range of chemical concentrations in the treatment rinse that will provide effective treatment without degrading the metal finish. As an example, the formulation necessary for a copper cyanide finish may differ from that for a brass cyanide finish. Literature on the subject does not provide any details on acceptable chemical content.

### 3. Operation and Maintenance Requirements and System Performance

Operator duties for an integrated treatment system include:

- Daily testing to determine need for addition of makeup chemicals.

- Periodic removal of any sludge that accumulates in the treatment reservoir.
- Scheduled maintenance of chemical pumps.

Generally, because the treatment is part of the plating process, the plater assumes responsibility for maintaining the correct chemical concentrations within the rinse. Chemical testing is not sophisticated; for a cyanide system it requires testing for pH and chlorine content. Occasionally, part of the chemical rinse should be discharged to control the buildup of dissolved solids.

Integrated treatment should be superior to conventional treatment for both cyanide oxidation and chromium reduction. The process has inherent advantages in that a significant excess of the treatment chemicals is maintained in the reservoir and the residence time of the pollutants is much greater. Further, for cyanide oxidation with integrated treatment, there is much less chance of forming complexes that are not amenable to chlorination.

#### 4. Residuals Generated

Integrated treatment employs basically the same chemical treatment as conventional approaches; so, ultimately, it generates the same forms of waste. An advantage, however, exists in that it allows certain wastes to be segregated. As an example, if the drag-out from a cadmium cyanide plating process had a dedicated integrated treatment system, the cadmium sludge would accumulate in the treatment reservoir, with two potential advantages. For one, the cadmium would not cause the rest of the waste treatment sludge to be toxic because of cadmium leaching; for the other, the cadmium may be suitable for recovery from the sludge if it is the only metal present.

#### 5. Cost Factors

An integrated treatment unit can be installed for as little as the cost of a chemical rinse station for dipping the plated parts in a manual plating line, or for the cost of a treatment reservoir, supply pump, piping and valves, and return piping for an automated system. The cost could be as low as \$500 or, if the system serves a number of plating baths, as high as \$20,000. Normally, as an option to a continuous, automated pretreatment system, the integrated approach will provide a cost savings.

Integrated treatment systems generally use treatment chemicals more efficiently because they do not treat large volumes of water. Consequently, loss stemming from residual content of the wastewater is avoided and the likelihood of reagent consumption by water contaminants is minimal.

## SECTION V

### MATERIAL RECOVERY TECHNOLOGIES

#### A. OVERVIEW

Pollution control legislation has affected electroplating operations by increasing the economic penalty associated with inefficient use of raw materials. For example, loss of a raw material in the wastewater can result in three distinct cost items: replacement of the material, removal of the material from the wastewater before discharge, and disposal of the residue. Similar cost items exist for process water: replacement of water (no longer inexpensive to purchase) used in processing, processing the water in the wastewater treatment system, and processing the water by the local sewer authority after discharge into a sewer system.

In response to the increased cost of raw material losses, industrial plating shops are applying various separation processes that reclaim plating chemicals from rinse waters, enabling both the raw material and the water to be reused. The effect of resource recovery and pollutant load reduction modifications on waste treatment and solid waste disposal costs must be measured if these modifications are to be evaluated for use by the military.

Recovery processes applicable to electroplating waste streams include the following:

- Evaporation
- Coupled transport membranes
- Electrodialysis
- Reverse osmosis
- Electrolytic cell processes
- Donnan dialysis
- Ion exchange
- Ion transfer membranes

Each technology is applicable to a limited number of specific wastestreams. Figure 48 summarizes the application of the above technologies.

RECOVERY TECHNOLOGY	PLATING BATH									
	DECORATIVE CHROMIUM	HARD CHROMIUM <sup>b</sup>	NICKEL	ELECTROLESS NICKEL <sup>b</sup>	CADMIUM (CN)	ZINC (CN)	ZINC (CI)	COPPER (CN)	TIN (BF <sub>4</sub> )	SILVER
EVAPORATION	●		●		●	●	●	●	●	●
ELECTRODIALYSIS			●		●	●	●	●	●	●
REVERSE OSMOSIS			●			●		●		
ION EXCHANGE	●		●	●						●
ELECTROLYTIC					●	●	●	●	●	●
DONNAN DIALYSIS										
ION TRANSFER MEMBRANES	●	●								
COUPLED TRANSPORT MEMBRANES	●									

<sup>a</sup> Indicates applications that have been commercially demonstrated or proven successful on full-scale pilot system.

<sup>b</sup> Low drag-out rate has limited applications of recovery technologies.

Figure 48. Summary of Recovery Technology Applications<sup>a</sup>

The foregoing processes all operate on the same basic principle; they concentrate the dragged out plating solution contained in the rinse water to the degree that the solution can be returned to the plating bath. Their use can result in an essentially closed system around a plating bath; no plating chemicals are consumed other than those plated on the ware, and no rinse water is sent to waste treatment. Except in the case of purge streams from the recovery unit, a recovery system (Figure 49a) can achieve zero effluent discharge.

Using a recovery unit requires reducing the volume of rinse water to a quantity that can be processed economically. The use of a multistage counterflow rinse system (see Figure 3) is therefore recommended. A bath purification system is needed to eliminate the buildup of contaminants in the closed-loop system resulting from return of the drag-out to the process bath. The drag-out formerly acted as a bleed stream and served to control the buildup of contaminants. The type of purification system required depends on the type of plating chemicals being recovered.

One objection to recovery systems is that the quality of the rinse operation may be compromised. Rinsing quality can be ensured by segregating the final rinse from the recovery process (Figure 49b), but this approach results in a rinse water flow to waste treatment.

The chemical recovery potential for a recovery system is shown as a function of rinse ratio in Figure 50. The curve is the same as that developed for the recovery potential of a two-stage rinse-and-recycle system. The major difference is that now the recovery rinse ratio is determined by the processing capability of the recovery unit, not the surface evaporation rate of the plating bath. Recovery processes should be considered for those baths for which rinse-and-recycle modifications are not applicable. If a plater can reclaim 90 percent of his drag-out losses by low-cost modifications to the plate line, then it would not be economical to install a recovery system.

When the rinse waters following a plating operation require a separate waste treatment system (chromium and cyanide are examples), closing the loop around the plating operation with a recovery system can avert the need for the treatment system. If a treatment system has not yet been built, the capital savings resulting from eliminating the treatment hardware will make the investment in recovery units more attractive.

In general, recovery is only cost effective for plating operations that are heavily used. The best application is with automatic plating machines that have a high drag-out rate. Most military plating operations are used intermittently and cannot provide the economic justification for recovery.

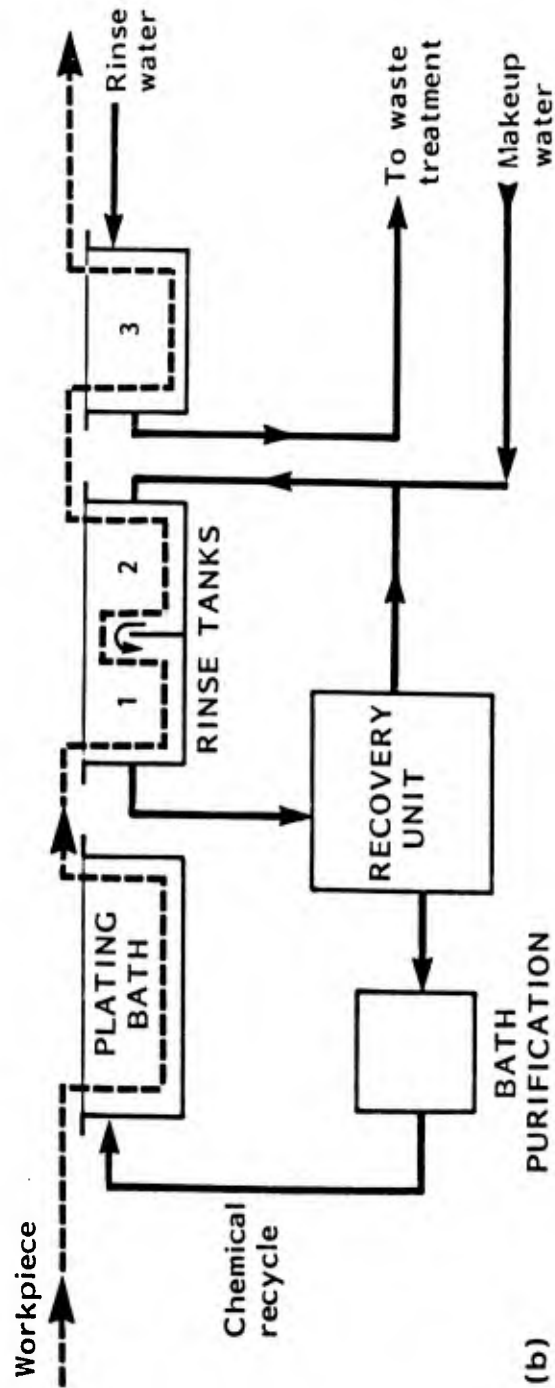
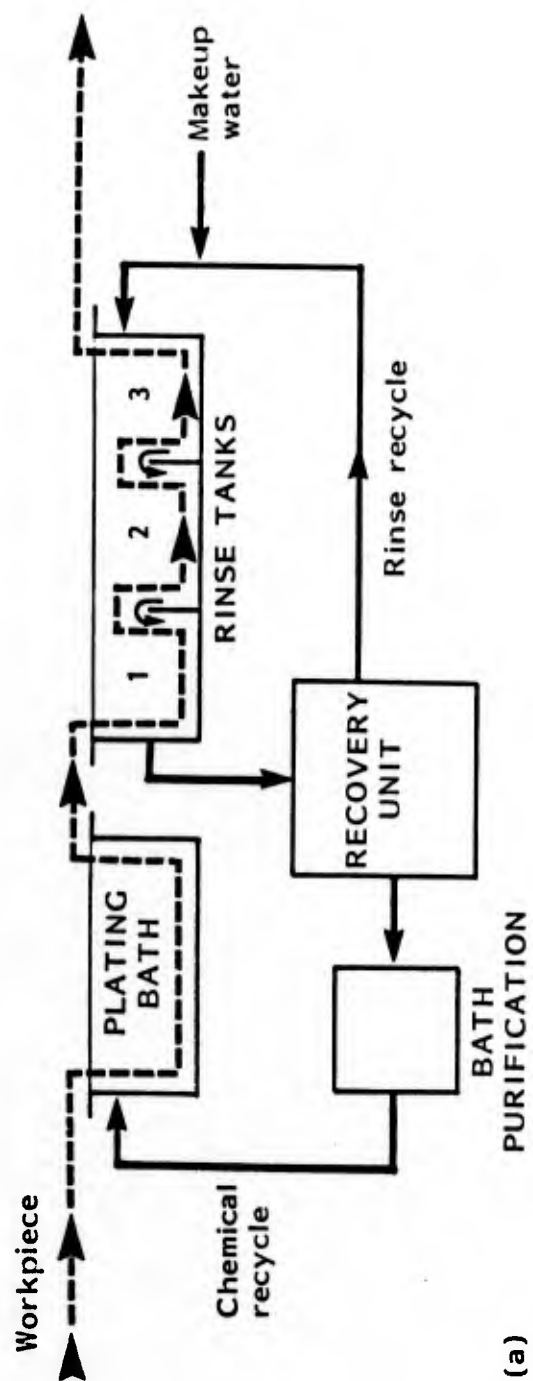
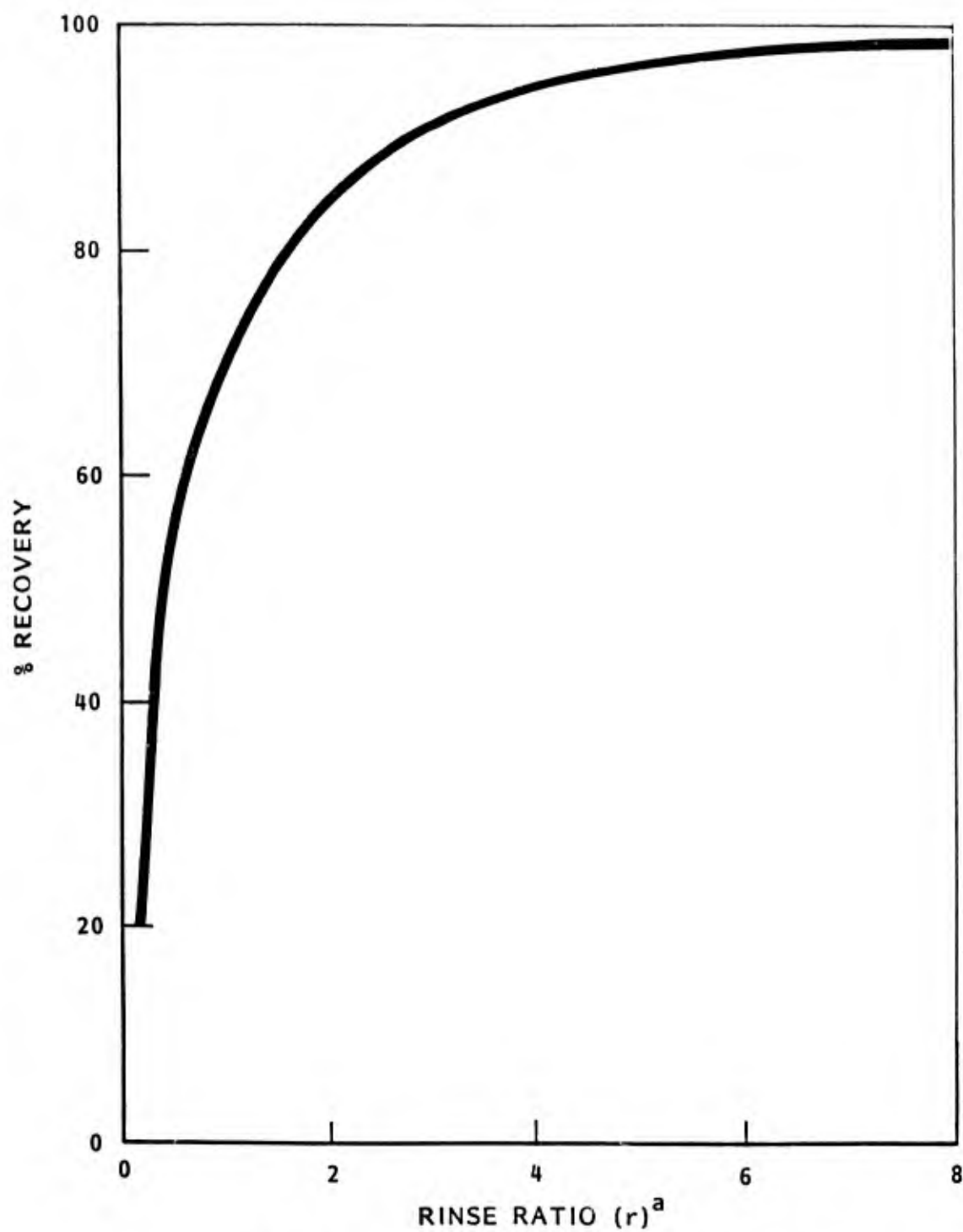

Figure 49. Recovery Systems: (a) Closed Loop, (b) Open Loop



<sup>a</sup> $r$ =recovery rinse (gal/h)/drag-out (gal/h).

Figure 50. Recovery Potential for a Two-Stage Counterflow Rinse

This section will examine the operating parameters, cost factors, and reliability of the different recovery systems used in the electroplating industry. The information will enable the electroplater, after an assessment of specific loss factors, to determine the economy that could be realized by installation of recovery units.

## B. EVAPORATION

### 1. Summary and State of Technology Development

Rising costs of plating chemicals and the potential savings resulting from their recovery from wastewaters were the primary incentive for purchase and installation of the first evaporative recovery systems; preventing pollution was secondary. The Pfaudler Company reports installation of its first evaporator in 1951 at a General Motors plant. Since that time many systems have been installed and operated successfully on a variety of plating solutions.

Evaporation is probably the most simple recovery technology in terms of the principle involved. It achieves recovery by distilling the plating wastewater until there is a sufficient concentration of plating chemicals to allow reuse in the plating bath. Because of the costs to operate them, thermal energy evaporators are not usually considered for recovery of plating chemicals from dilute wastewater. Installation of countercurrent rinse systems, however, increases chemical concentrations in wastewater to a level where evaporative recovery can be considered.

Evaporation can offer favorable returns on investment and can reduce the pollutant loading requiring treatment. The technology is proven and its application is expanding. The evaporation system shown in Figure 51 can be used to recover plating chemicals contained in the effluent from a three-stage countercurrent rinse. The feed to the evaporator is the discharge from the first rinse tank. The plating chemicals are concentrated in the evaporator and returned to the plating bath. The water vapor is condensed and returned to the rinse tanks.

Four types of evaporators are used throughout the electroplating industry (Reference 41):

- Rising film evaporators
- Flash evaporators using waste heat
- Submerged tube evaporators
- Atmospheric evaporators

Site-specific conditions and the mode of operation determine construction materials and influence the selection of one system over another.

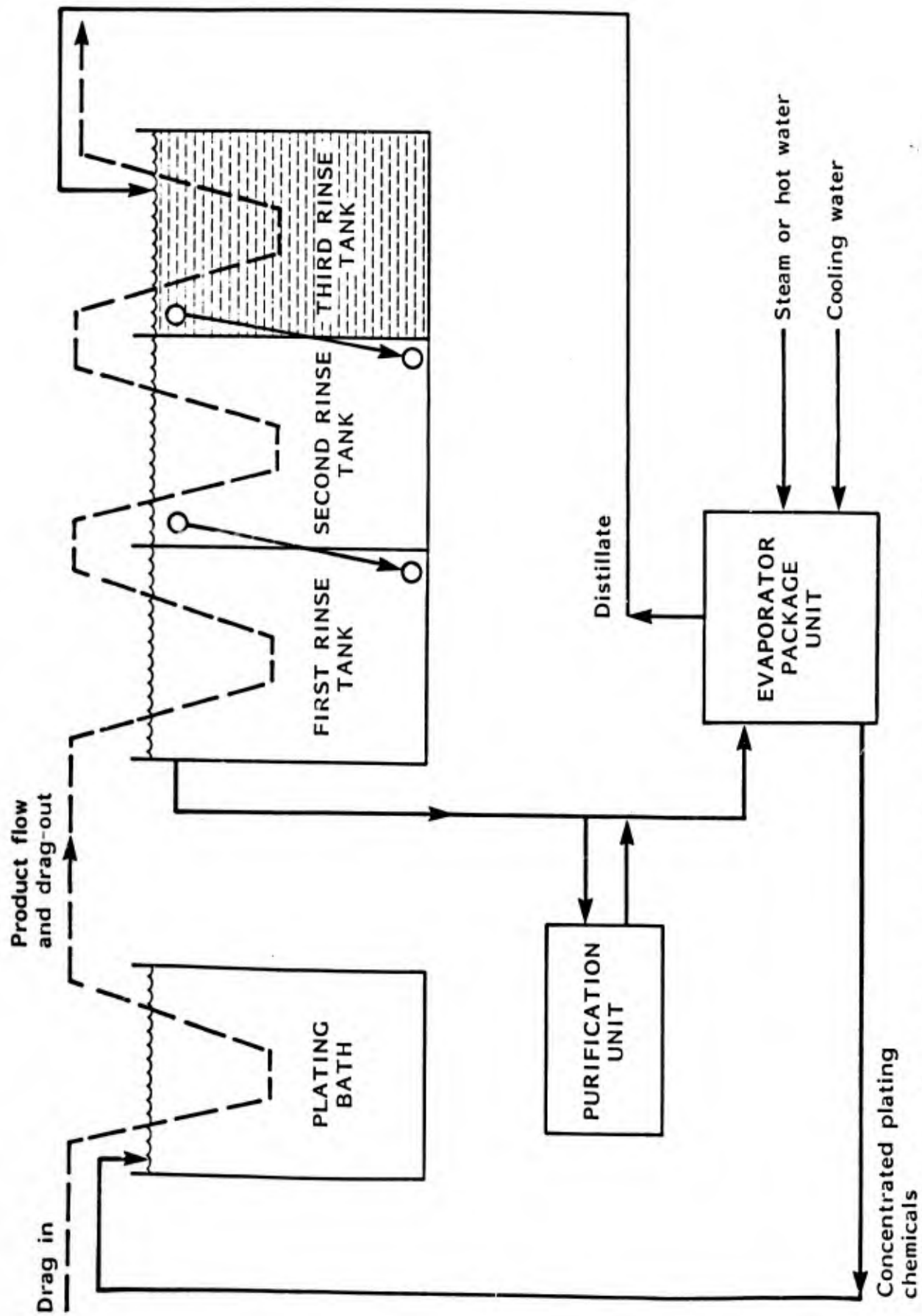

Figure 51. Closed-Loop Evaporative Recovery of Plating Chemicals from Drag-Out

## 2. Types of Evaporators

Rising film evaporators are built so that the evaporative heating surface is covered by a wastewater film and does not lie in a pool of boiling wastewater. A complete unit usually consists of a reboiler, separator, and condenser, as shown in Figure 52. The reboiler is a shell-and-tube heat exchanger in which the heat from low pressure steam--5 to 15 lb/in<sup>2</sup> gauge--or hot water is transferred to the wastewater. The wastewater can be circulated naturally or forced through the tubes, or it may be a rising film on the outside of the tubes. Because some plating chemicals are susceptible to degradation at high temperatures, evaporation is accomplished at pressures of 1.3 to 7.5 lb/in<sup>2</sup> absolute, thereby lowering the boiling point to 110°-180°F. The operating pressure varies with manufacturers and the type of plating chemicals being handled. Reduced wall temperatures of the heat transfer surface will reduce scale and thermal breakdown of plating chemicals. The wastewater leaves the reboiler as a vapor/droplet mixture and enters the separator.

The separator serves two functions: . it separates the water vapor from the heavier plating solution and it provides a reservoir for the concentrated plating solution to collect until it is returned to the bath. One manufacturer employs a separate concentration tank to serve the same function as the reservoir in the separator. The water vapor exits through the top of the separator. A recirculation loop continuously recirculates the separated plating solution through the reboiler and separator until the concentration increases to a preset level. At this point, the wastewater flow is momentarily valved off, allowing the concentrated plating solution to return to the bath or holding tank. This step takes only a few minutes, then the wastewater flow to the reboiler is resumed. Some systems operate with a continuous return and do not require this valve cycling.

The vapor leaving the separator is condensed in a shell-and-tube heat exchanger and the distillate is returned to the rinse tanks or for other plant uses. Cooling water is supplied by cooling towers or reservoirs. Once-through process water is also used.

Flash evaporators, as shown in Figure 53, are of the same basic design as the rising film evaporators. The main difference is that plating solution from the bath is recirculated continuously through the evaporator. This recirculation reduces overall energy requirements for evaporation and cools the bath solution as well.

During the plating operation, the temperature of the plating bath increases because of the electrolytic process. Cooling coils are installed to maintain the bath temperature.

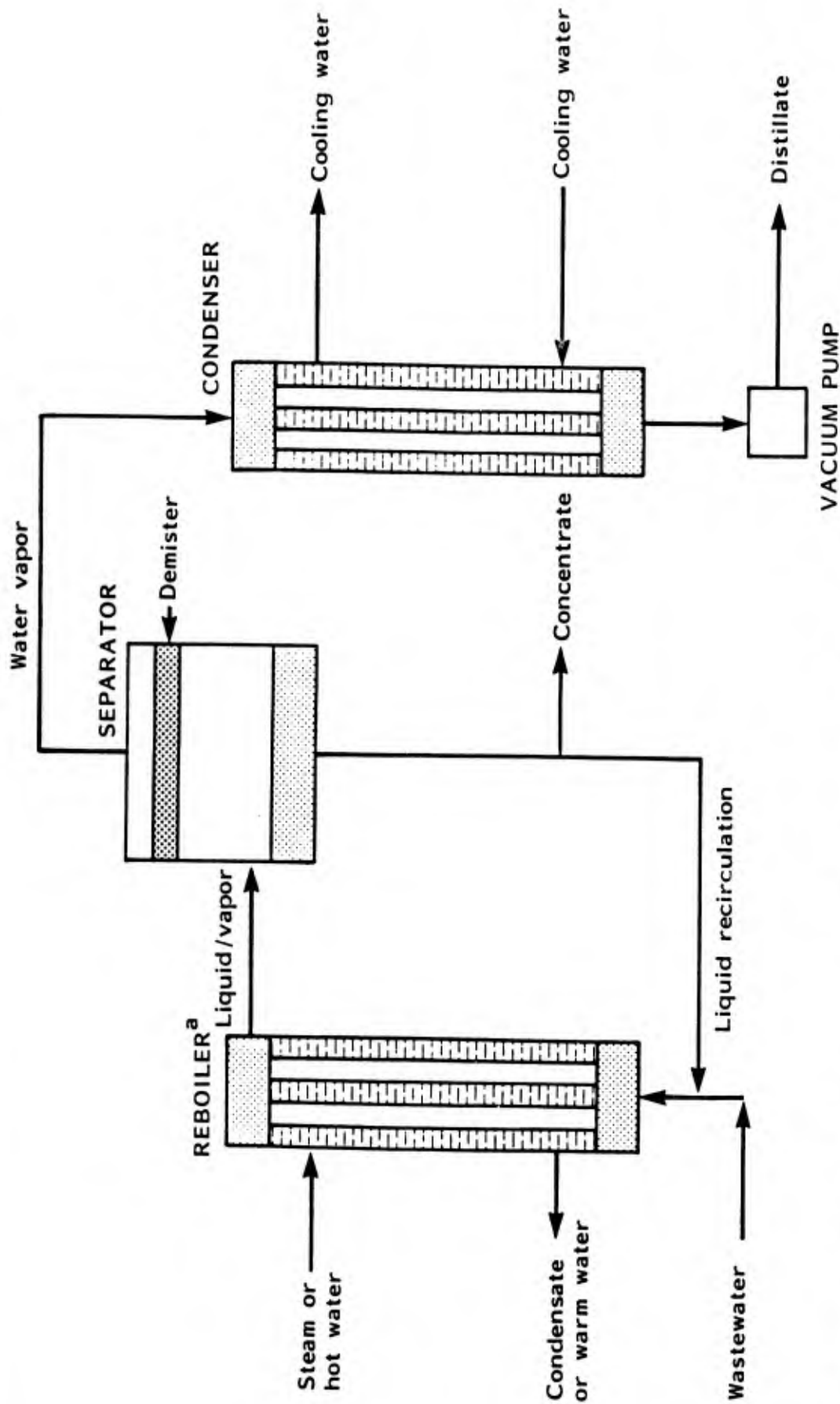

<sup>a</sup>The heating medium and wastewater may be interchanged in the shell and tubes, depending on the manufacturer.

Figure 52. Rising Film Evaporation for Chemical Recovery

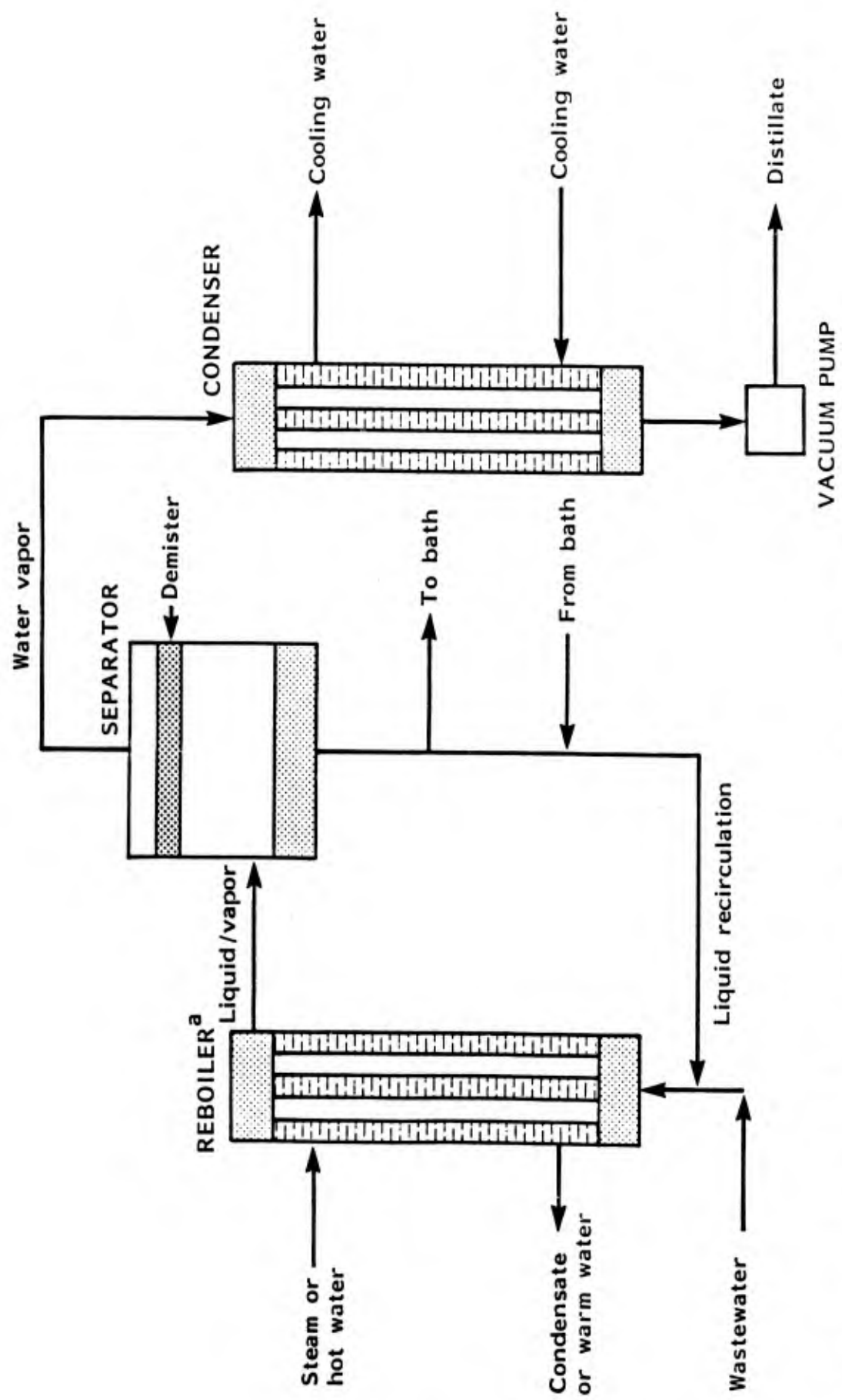

<sup>a</sup>The heating medium and wastewater may be interchanged in the shell and tubes, depending on the manufacturer.

Figure 53. Flash Evaporation for Chemical Recovery

An alternative approach for cooling high temperature baths is to withdraw a part of the plating solution for feed to flash evaporators. The plating solution from the bath is at a temperature above its boiling point at the pressure maintained in the evaporator. A small part of the plating solution, therefore, vaporizes in the separator, and thus reduces the temperature of the solution and provides heat to the wastewater being evaporated. If the evaporator is operating at a pressure of 1.3 lb/in<sup>2</sup> absolute and the temperature of plating bath is 135°F, the plating solution will flash cool to 110°F. The 110°F plating solution is recycled to the plating bath to maintain the bath temperature at 135°F.

To save 1 pound of steam in the flash evaporator, approximately 5 gallons of plating solution must be flash cooled by 25°F in the evaporator. If a rising film evaporator required 1,000 lb/hour of steam, a flash evaporator could achieve the same concentration rate using 800 lb/hour of steam if 1,000 gal/hour--based on 5 gal/lb-steam x 200 lb-steam/hour--of plating solution is fed to the unit. The amount of heat removed from the bath cannot exceed the cooling duty. Therefore, the plating bath cooling requirements are at least 200,000 Btu/hour--200 lb-steam/hour x 1,000 Btu/lb-steam. Because the quantity of heat provided by the flash cooling of the plating bath solution is small compared with the latent heat provided by steam heating, flash evaporation usually is limited to large, high-temperature plating installations.

Submerged tube evaporators operate on a slightly different principle from that of film or flash evaporators for supplying thermal energy to the wastewater. As shown in Figure 54, steam, at 5 to 15 lb/in<sup>2</sup> gauge, or hot water, at approximately 160°F, is supplied to heating coils that are immersed in the boiling wastewater. A single-effect unit consists of one vessel that includes internal heating coils for evaporation, a moisture separator, and cooling coils for condensing water vapor. The boiling wastewater is not recirculated, as it is in rising film and flash evaporators.

Submerged tube units are designed to operate under a vacuum as low as 0.7 to 1.3 lb/in<sup>2</sup> absolute. The vacuum is created by diverting part of the cooling water through an eductor external to the unit. The distillate is recycled to the rinse tanks or for other plant uses. The plating solution is recycled to the plating tanks after the desired concentration is reached.

The cost for submerged tube evaporators is usually lower than that for rising film or flash units, primarily because of the integrated evaporation/condensation single-unit design. The steam or thermal demand is the same as that for rising film evaporators.

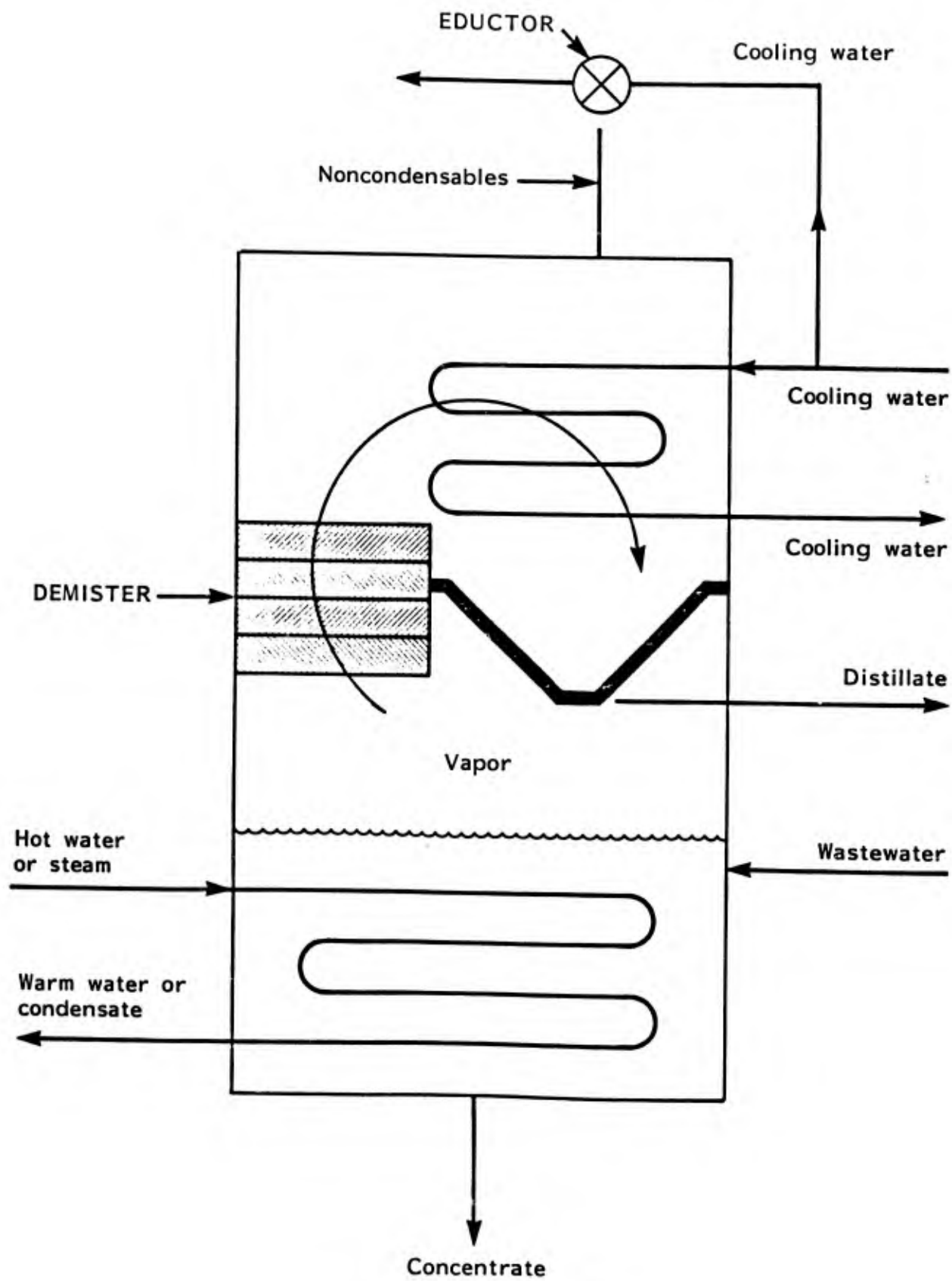

Figure 54. Submerged Tube Evaporation for Chemical Recovery

Atmospheric evaporators, as shown in Figure 55, do not recover the distillate for reuse and do not operate under a vacuum. Wastewater is evaporated by using it to humidify air flowing through a packed tower. The humidified air is exhausted to the atmosphere; this procedure eliminates the need for cooling water and a condenser. The concentrate from the reservoir is circulated continuously through the packed tower at a rate of approximately 50 gal/min. Contaminated rinse water enters the system and mixes with the concentrate in the reservoir. The wastewater is recirculated through the shell-and-tube heat exchanger, where steam is used to raise the temperature of the solution to approximately 160° to 170°F. Ambient air is drawn in through the packed tower, where it becomes saturated with water vapor and is exhausted to the atmosphere. Because the exhaust air removes some of the heat supplied by the wastewater heat exchanger, this type of unit requires approximately 20 percent more steam than do evaporators of other designs.

Deionized water is added to the rinse tanks to make up for all of the water lost to the humidified air. Deionized water is required to minimize the scale deposit from evaporation and to prevent mineral buildup in the plating tanks via the returned solutions.

### 3. Operating and Maintenance Requirements and System Performance

The major operating costs for evaporators include operating labor, maintenance, and utilities. The utility requirements include steam or hot water, cooling water, and electricity. Instrumentation and controls may be electrical or pneumatic; if pneumatic, an air supply will be required.

Evaporators usually are trouble-free systems that require, typically, less than one-half hour per shift of operator attention. Evaporator operation may be manual or automatic (Reference 41).

A manual system is started up by opening the steam supply and the wastewater inlet valves and starting the recirculation, vacuum, and cooling water pumps. In some systems, the vacuum pump and distillate pump are the same; in others, the cooling water pump also creates the vacuum through an eductor. The system is shut down by closing the wastewater inlet and steam supply valves.

Some automatically controlled systems are equipped with concentration sensor/controllers that monitor the plating concentration. When the desired concentration is reached, the automatic controls close the wastewater inlet valve and return the concentrate to the plating bath or holding tank. The systems are sized so that the return of the plating chemicals to the bath occurs approximately once per shift. Other systems are designed to operate continuously with no interruption to the wastewater feed.

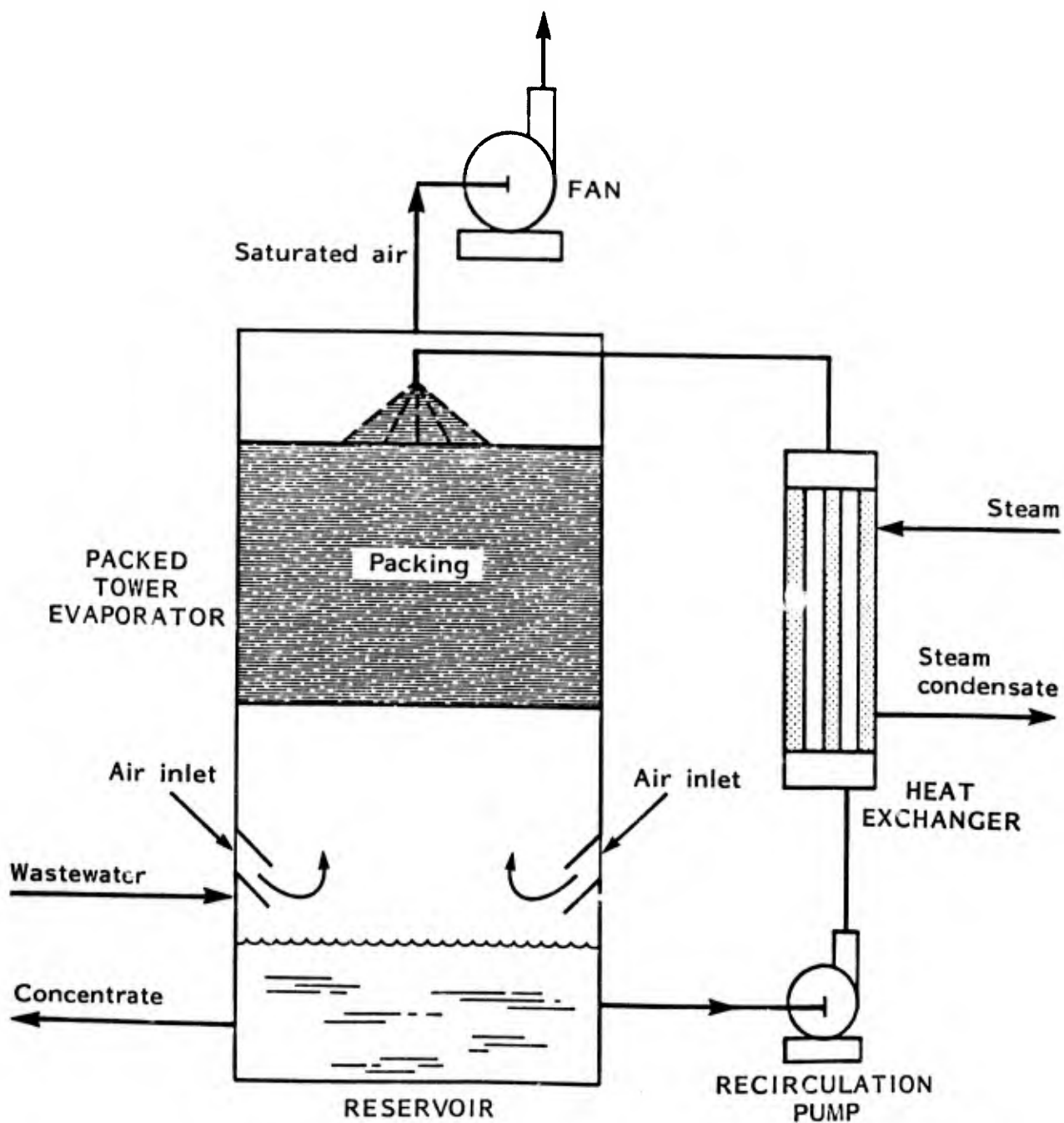

Figure 55. Atmospheric Evaporation for Chemical Recovery

Most evaporators used in the plating industry are single-effect units. Single-effect evaporators operate with one reboiler or evaporator section. The water vapor is condensed or exhausted to the atmosphere. Approximately 1.1 pound of steam is consumed in evaporating each pound of water from the plating solution. Various methods can be employed for reusing the thermal energy of the water vapor to reduce the thermal energy demand; however, additional capital investment is required.

Figure 56 shows the utility requirements for single-effect evaporators as a function of wastewater flow rates to the evaporator. Because the typical application requires evaporation of over 98 percent of the water, the evaporator ratings are based on wastewater flow rates. Changes in concentration of the plating chemicals do not affect the utility demand significantly if the flow rate remains constant; however, the plating chemical concentration will have a significant effect on the economics and cost savings.

The electrical demand is associated with power requirements for the vacuum pump, recirculation pump, and feed pump. As a rule, the cooling water rates are based on a temperature rise of 25°F across the condenser.

For example, from Figure 56, if the wastewater flow rate to the evaporator is 80 gal/hour, the steam rate is 730 lb/hour for 15 lb/in<sup>2</sup> gauge steam. The electrical demand is 2.9 kWh and the cooling water rate is 56 gal/min. For atmospheric evaporators where no cooling water is used, the steam rate would be at least 20 percent higher.

#### 4. Methods for Reducing Steam Rates

Two techniques have been applied successfully to reduce steam demand for evaporation, both involve reusing the heat value contained in the vapor from the separator.

The most common technique is to use a double-effect evaporator, as shown in Figure 57. In this system, approximately 50 percent of the wastewater is concentrated in the first effect using steam. The vapor from the separator of the first effect enters the second-effect reboiler and condenses to provide the thermal energy required to reach the final concentration of the plating solution. Rising film, flash, and submerged tube evaporators can be employed in this manner; however, the capital costs are significantly increased because of the need for an additional reboiler and separator. The steam and cooling water rates for the double-effect unit (Figure 58) are approximately 50 percent of those required for the single-effect unit (see Figure 56).

Some platers using double-effect units achieve an additional benefit by recovering two different plating baths

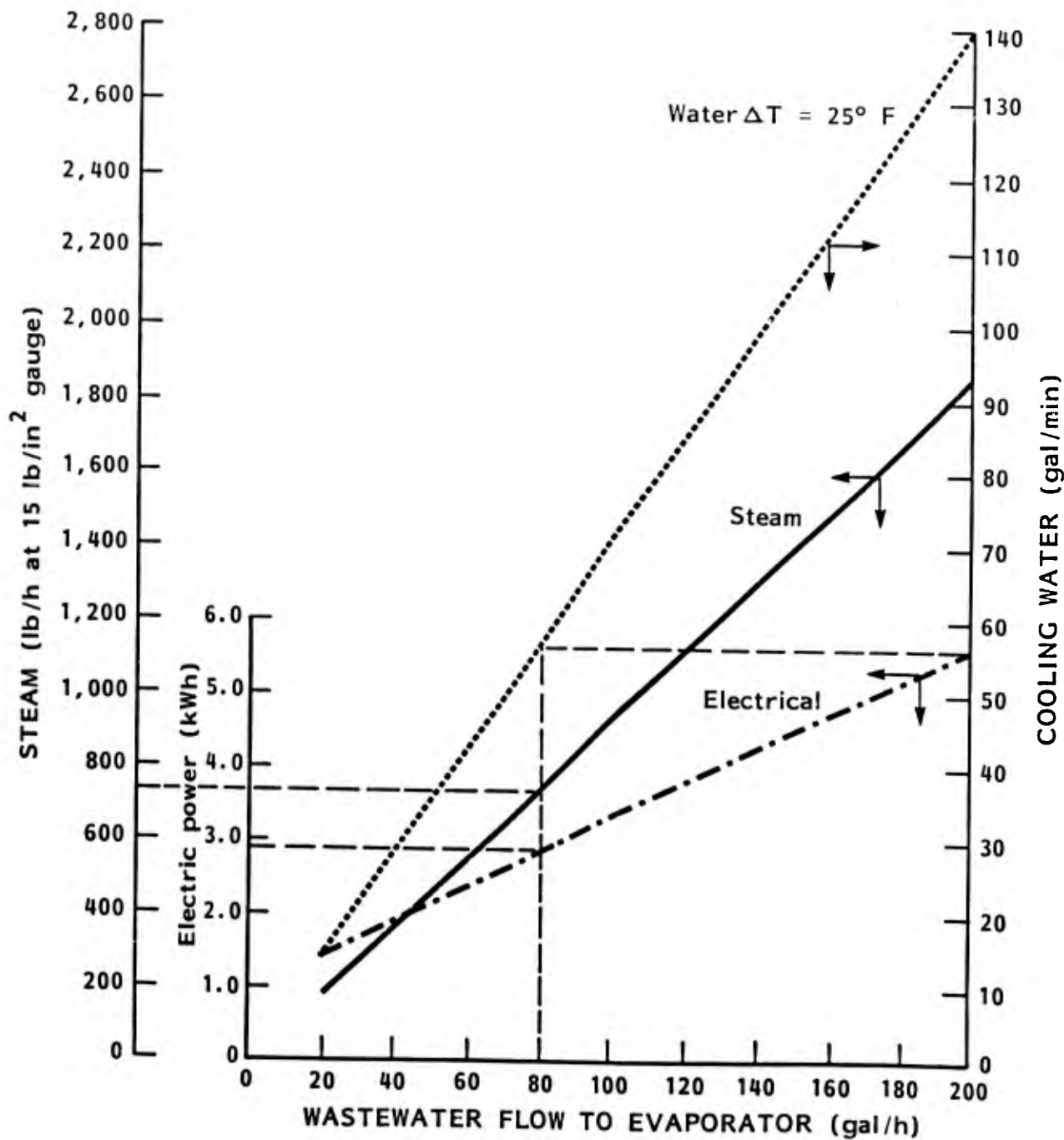

Notes.—Evaporation at 1.3 lb/in<sup>2</sup> absolute. Wastewater feed at 100° F. Cooling water supply at 70° F. Steam supply at 15 lb/in<sup>2</sup> gauge. Rising film or submerged tube. Example: A single effect evaporator boiling 80 gal/h of wastewater at 1.3 lb/in<sup>2</sup> absolute pressure has the following utility requirements: steam (15 lb/in<sup>2</sup> gauge). 730 lb/h; electric power, 2.9 kWh; cooling H<sub>2</sub>O at T = 25° F, 56 gal/min.

Figure 56. Utility Requirements for Single-Effect Evaporation

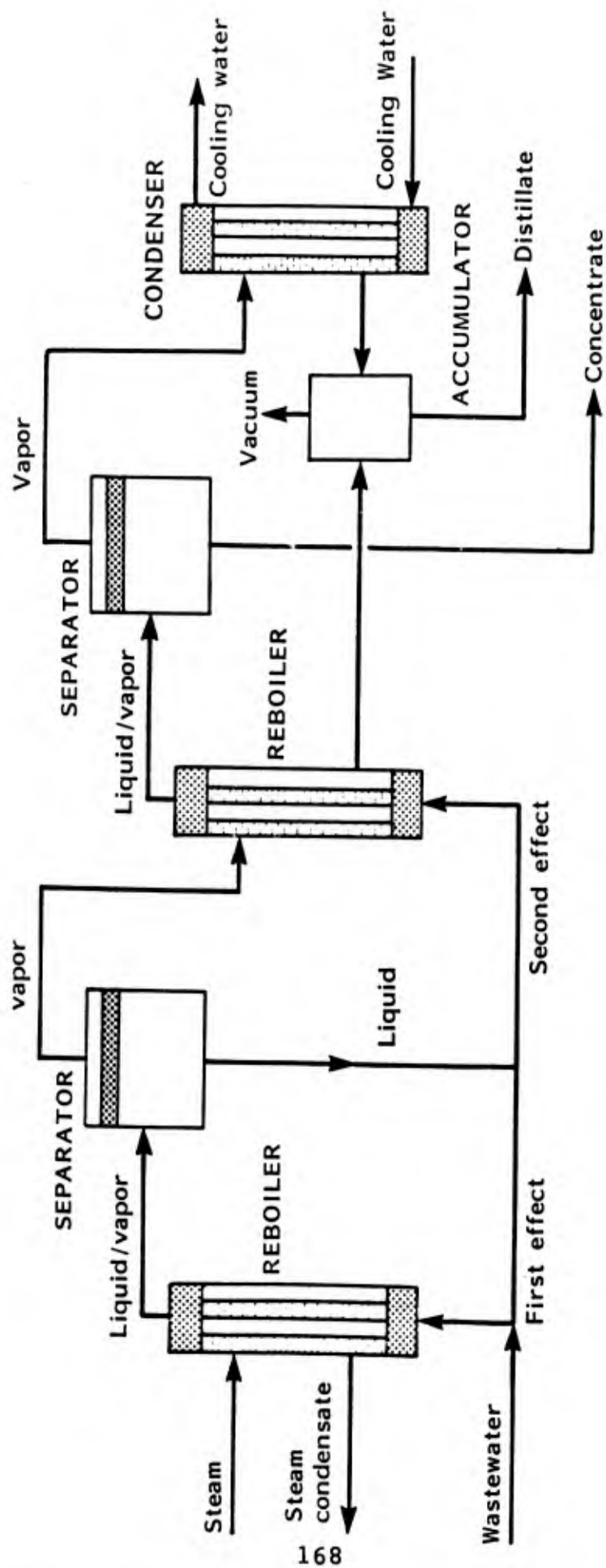
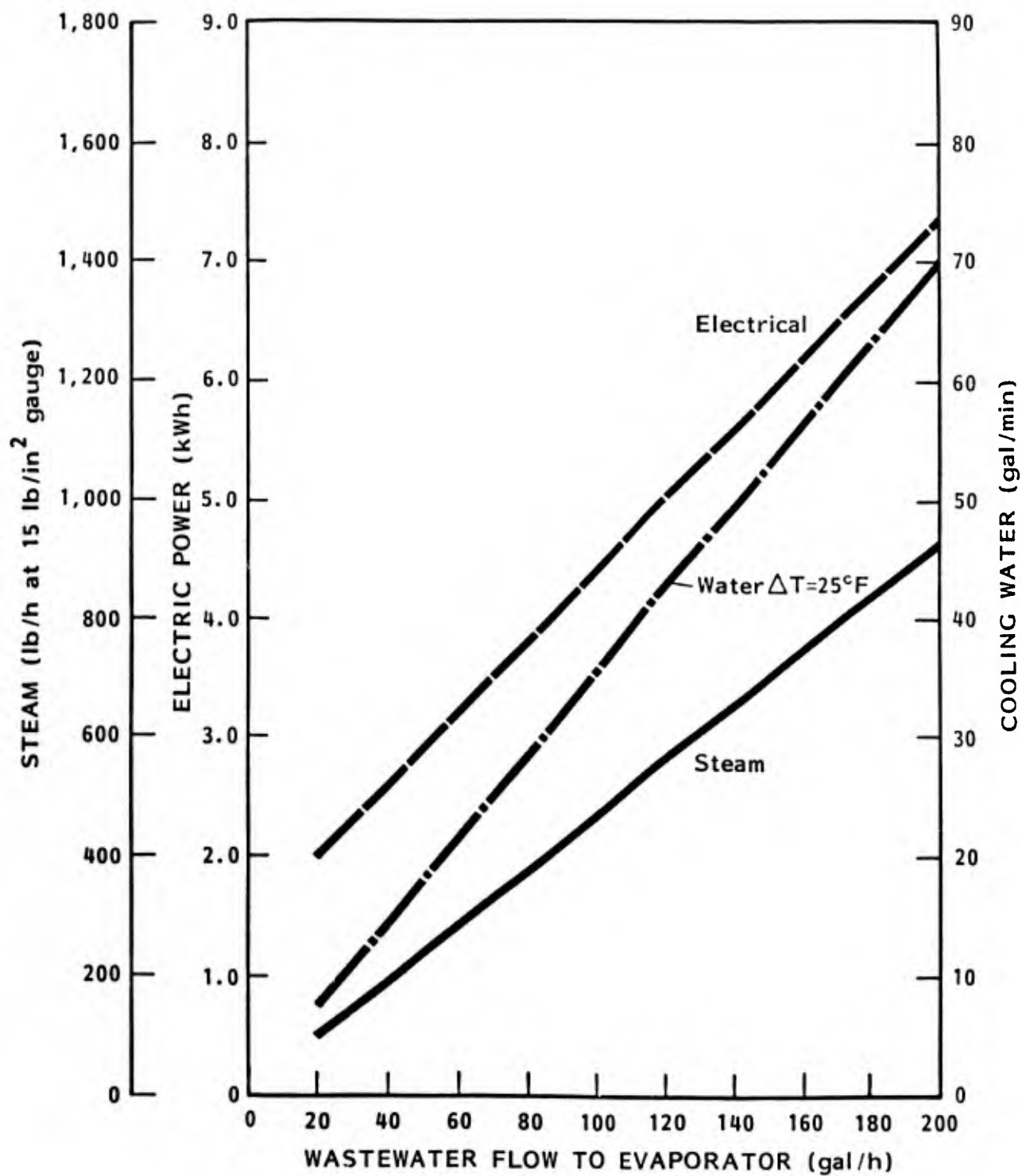

Figure 57. Double-Effect Evaporation for Chemical Recovery



Notes.—Wastewater feed at 100° F. Cooling water supply at 70° F. Steam supply at 15 lb/in<sup>2</sup> gauge.

Figure 58. Utility Requirements for Double-Effect Evaporation

simultaneously. Care must be taken in employing this arrangement, however, because there is a possibility of cross-contaminating baths.

The second technique is to use a mechanical compressor (Figure 59). The water vapor from the separator enters the suction of the compressor where its temperature and pressure are increased. The vapor is then desuperheated and enters the reboiler. The mechanical vapor recompression system requires only electricity (no external steam or cooling water); this characteristic eliminates the need for capital investment in boilers and cooling towers. Currently the application of this system is limited to alkaline plating solutions because acid carryover can cause corrosion damage to the compressors.

The initial investment cost for mechanical vapor recompression is the highest among equivalent capacity single- and double-effect units; however, this technique has the lowest operating cost (Reference 41).

Figure 60 shows the electric utility requirements for mechanical vapor recompression units as a function of capacity.

The application of mechanical vapor recompression and multiple-effect evaporators should be considered when the additional investment costs can be economically justified by the reduced operating costs.

The capacity of the evaporator will depend on the rinse flow rates and the level of recovery desired. The mass flow rate of the plating chemicals entering the rinse tank is based on drag-out. This rate sets the total raw material savings. The concentration of the plating chemicals entering the evaporator will depend on the rinse ratio and the number of rinse tanks for a fixed dragout concentration and rate. Because the utility requirements and evaporator capacity are primarily a function of rinse water flow rate, it is important to reduce the flow rate to the evaporator by using multiple rinse tanks, thereby increasing the concentration of plating chemicals. An optimum closed-loop or open-loop system can be developed to reduce the costs for evaporation.

If three or more rinse tanks are used, the rinse ratio usually will be low enough to make closed-loop recovery economical. The closed-loop system allows maximum recovery of plating chemicals. For example, if a plant operating a chromium plating bath at a concentration of 45 oz/gal and having a three-tank rinse system maintains the final rinse concentration at 0.002 oz/gal, the required rinse ratio would be 28. If the drag-out rate were 1 gal/hour, then a closed-loop evaporator system would require a minimum capacity of 28 gal/hour. Recovery of 99 percent of the drag-out would be possible.

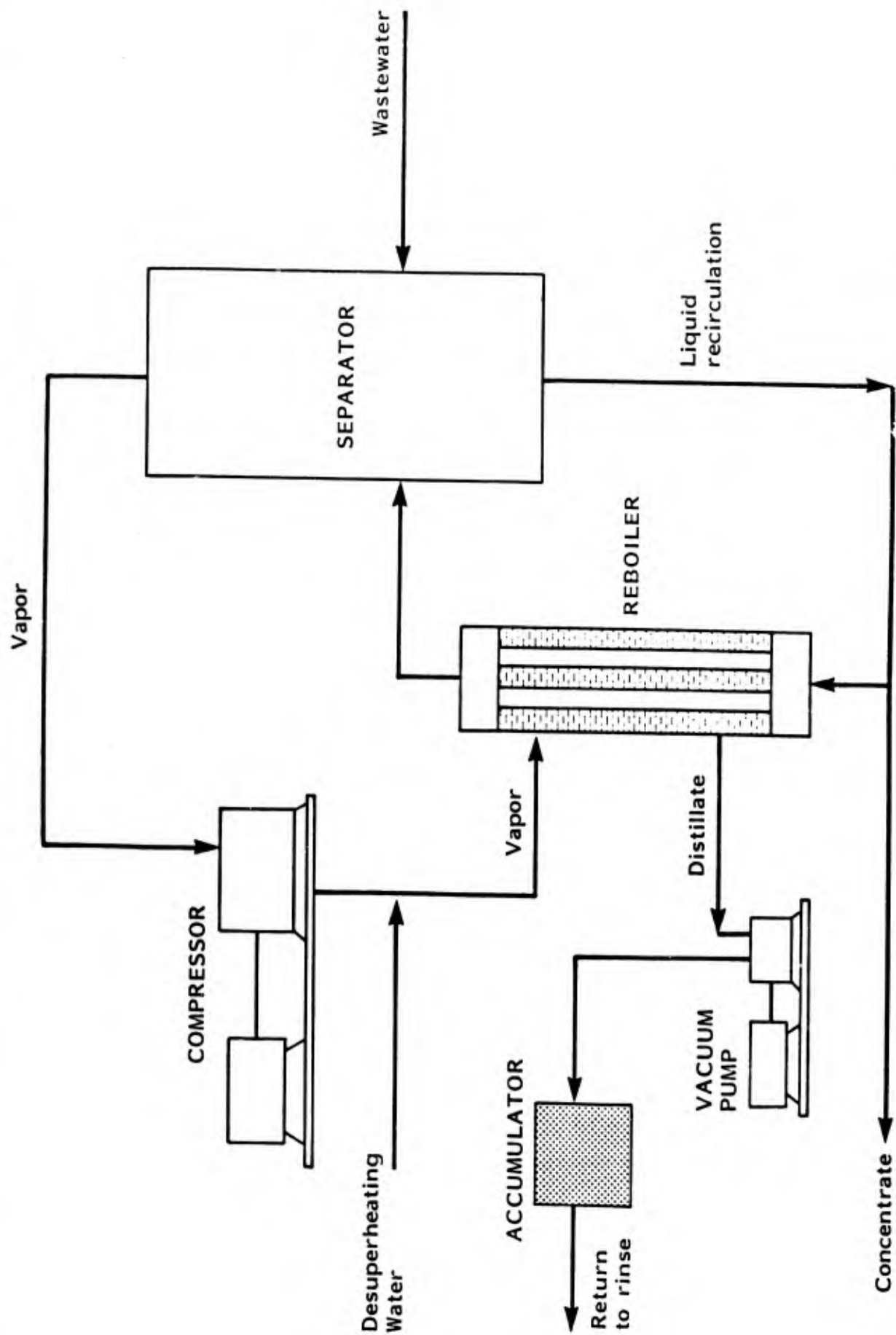
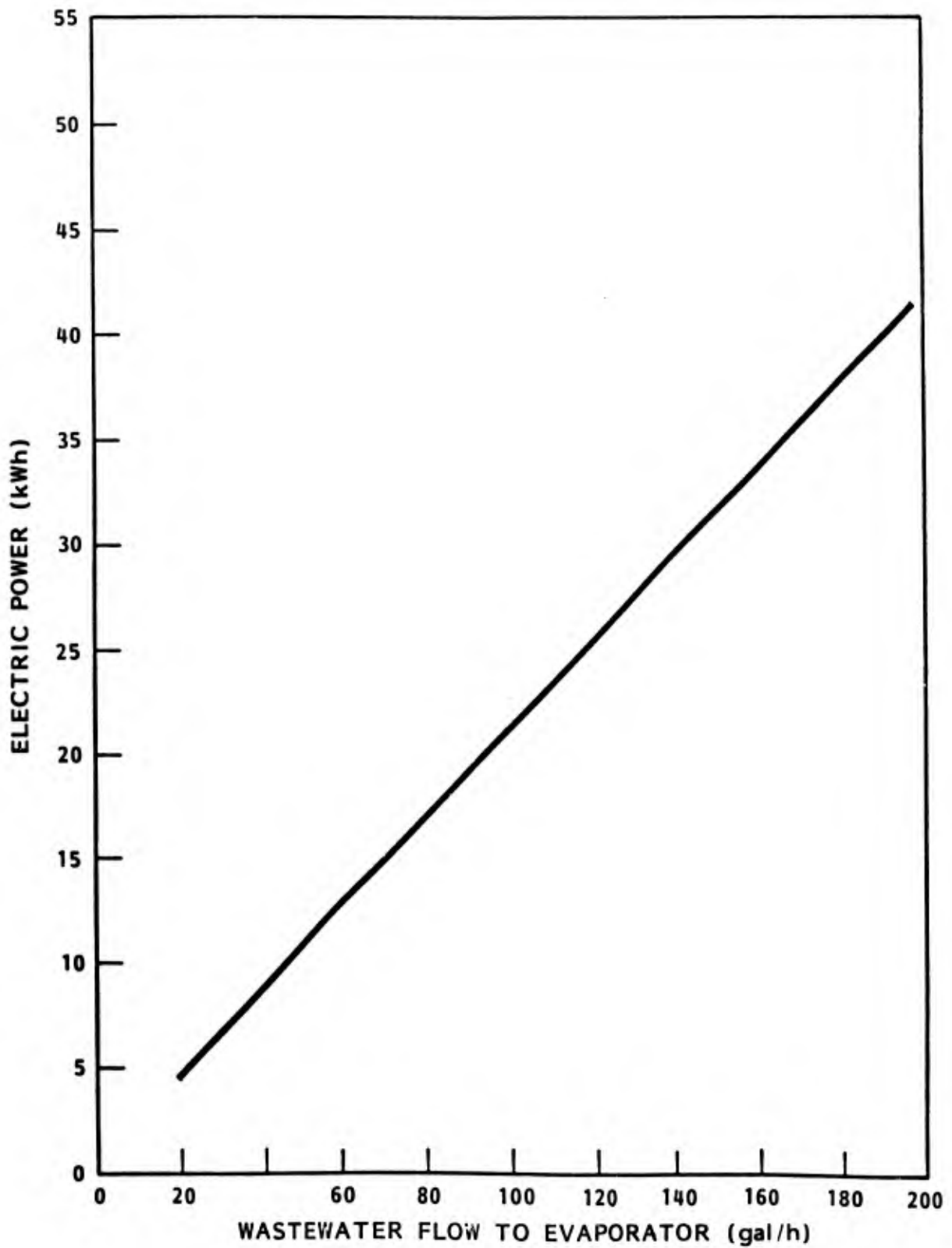

Figure 59. Mechanical Vapor Recompression Evaporation for Chemical Recovery



Note.—Compression ratio, 2:1. Compressor efficiency, 66%.  
 Distillate pump not included. Suction pressure, 1.3 lb/in<sup>2</sup> absolute.  
 Discharge pressure, 2.6 lb/in<sup>2</sup> absolute.

Figure 60. Utility Requirements for Mechanical Vapor Recompression Units

A similar plant having the same plating bath and final rinse tank concentrations, but having only two rinse tanks, would require a rinse ratio of 150 (Figure 61). At the drag-out rate of 1 gal/hour, the minimum evaporator capacity would be 150 gal/hour, or a little greater than five times the capacity of a three-tank rinse system. The same 99 percent plating recovery would result.

The plant with the two-stage rinse system would have two alternatives: it could install another rinse tank or it could operate the two rinse tanks as an open-loop recovery system (Figure 62). The disadvantage of an open-loop system is that the rinse water rate of the final rinse tank (which requires chemical treatment) will increase considerably. The overall recovery of the two-stage system, however, will be only slightly lower than that achievable with the three-tank rinse system.

At a rinse ratio of 28 in the first rinse tank, there is 96.5 percent recovery of plating chemicals from drag-out. The rinse ratio for the second tank is set to maintain the final rinse concentration of 0.002 oz/gal. This rate is calculated by determining the concentration in the first rinse tank, which, at a rinse ratio of 28 and a plating bath concentration of 45 oz/gal, is 1.6 oz/gal. Figure 62 will give the rinse ratio required in the second tank to achieve a dilution ratio of 800 ( $C_p/C_n=800$ ). If the drag-out rate were 1 gal/hour, the rinse water flow rate needed in the second tank to achieve the final discharge concentration of 0.002 oz/gal would be 800 gal/hour.

If an open-loop system with a two-stage rinse is used, the volume of wastewater processed by the evaporator is the same as the volume processed in a three-stage closed-loop system--28 gal/hour. Although the utility requirements are the same for evaporation, the open-loop system will result in slightly less chemical recovery and in increased rinse water and chemical treatment costs.

For plants that cannot reduce the rinsing rates, open-loop systems provide the opportunity to use evaporative recovery in an economically feasible manner. As a rule, the most economical approach is to add additional rinse tanks to minimize the rinse rate required in a recovery rinse and in a free rinse, where chemical treatment of the rinse water is required.

## 5. Cost Factors

The investment costs for evaporators depend on the capacity, design, and materials of construction. For each type of evaporator, the major difference in investment costs depends on the materials of construction. Most evaporators are supplied as package units and only require the hook up of utilities before startup.

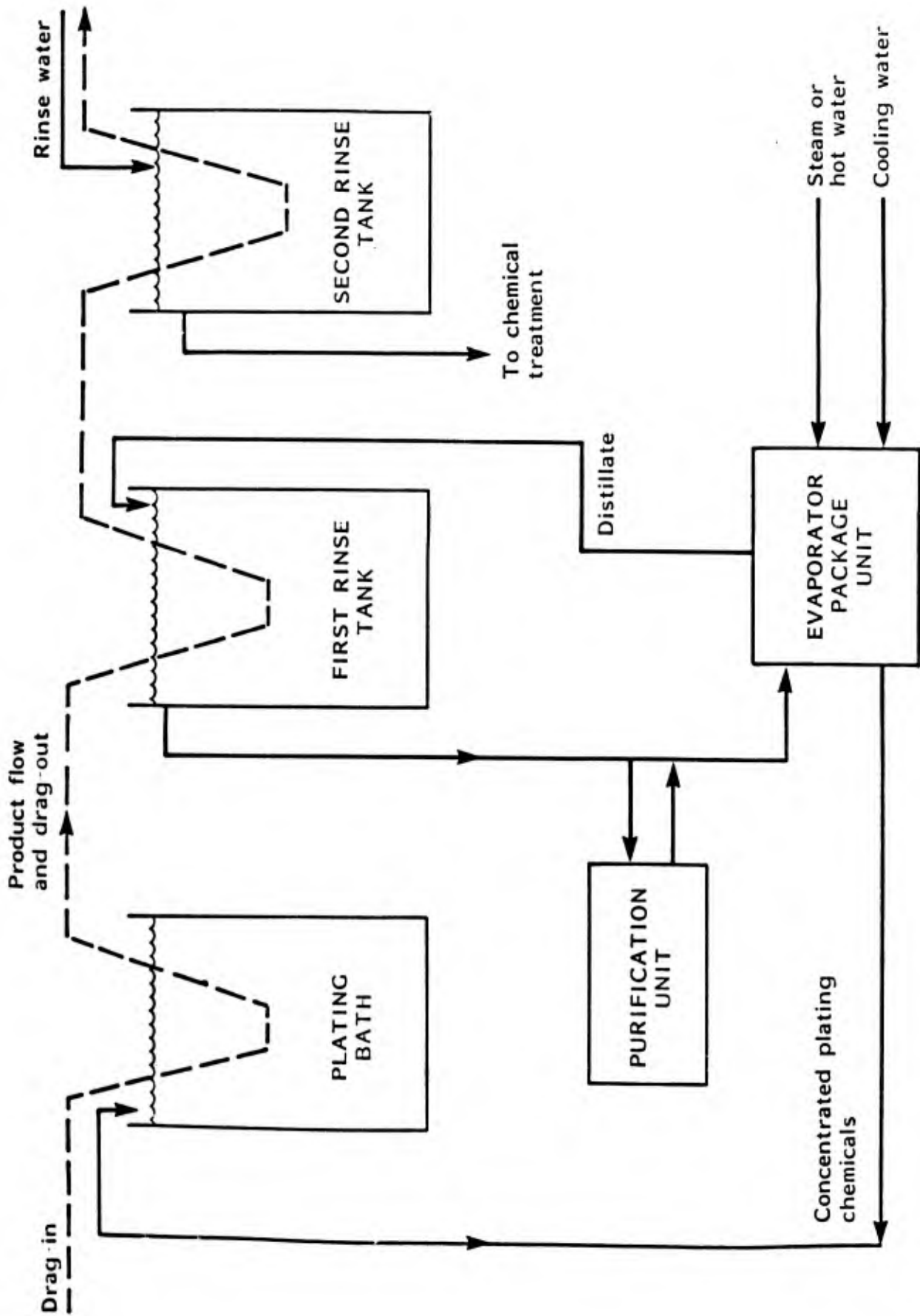

Figure 61. Open-Loop Evaporative Recovery of Plating Chemicals from Drag-Out

Evaporators currently are marketed with a wide range of construction materials to resist the corrosiveness of many of the plating chemicals. The more popular materials include titanium, tantalum, borosilicate glass, fiberglass-reinforced plastic (FRP), stainless steel, and polyvinyl chloride (PVC). Carbon steel can be used for recovery of alkaline cyanide solutions. Carbon steel is also used for condensers when there is no chance for rust contamination of the distillate.

Figure 63 shows the approximate installed costs for complete package, single-effect, rising film evaporators excluding a bath purification system. The investment costs for submerged tube evaporators are approximately 30 percent lower, primarily because of the integrated evaporator/condensation single-unit construction.

For rising film evaporator capacities above 100 gal/h, the investment costs for double-effect units will be approximately 30 percent higher than for single-effect systems. The investment costs for mechanical vapor recompression evaporators are approximately 50 percent higher than for single-effect units. Maintenance costs also are higher for mechanical vapor recompression units. The costs for installation of package evaporators range from 10 to 25 percent of the hardware costs. Installation costs for larger evaporators will be a lower percentage of the hardware costs because essentially the same utility hook-ups are required and only line sizes will change. The economics for evaporative recovery systems depend primarily on savings in plating chemicals and wastewater treatment costs.

## 6. Residuals Generated

Evaporative recovery offers the decided advantage that no residuals are generated. In fact the system can be completely close looped; that is, all the rinse waters are distilled and sent back for reuse in rinsing. The recovered chemicals are returned to the plating bath; and no effluent from the system exists.

## C. COUPLED TRANSPORT MEMBRANES

### 1. Summary and State of Technology Development

The use of coupled transport membranes has progressed to the stage of pilot evaluations of prototype units in actual industrial applications. The technology has not yet reached commercialization to the degree that a pre-engineered system is available for purchase.

The process of coupled transport is based on the use of specially constructed microporous membranes. These membranes are saturated with a water immiscible organic solvent and then

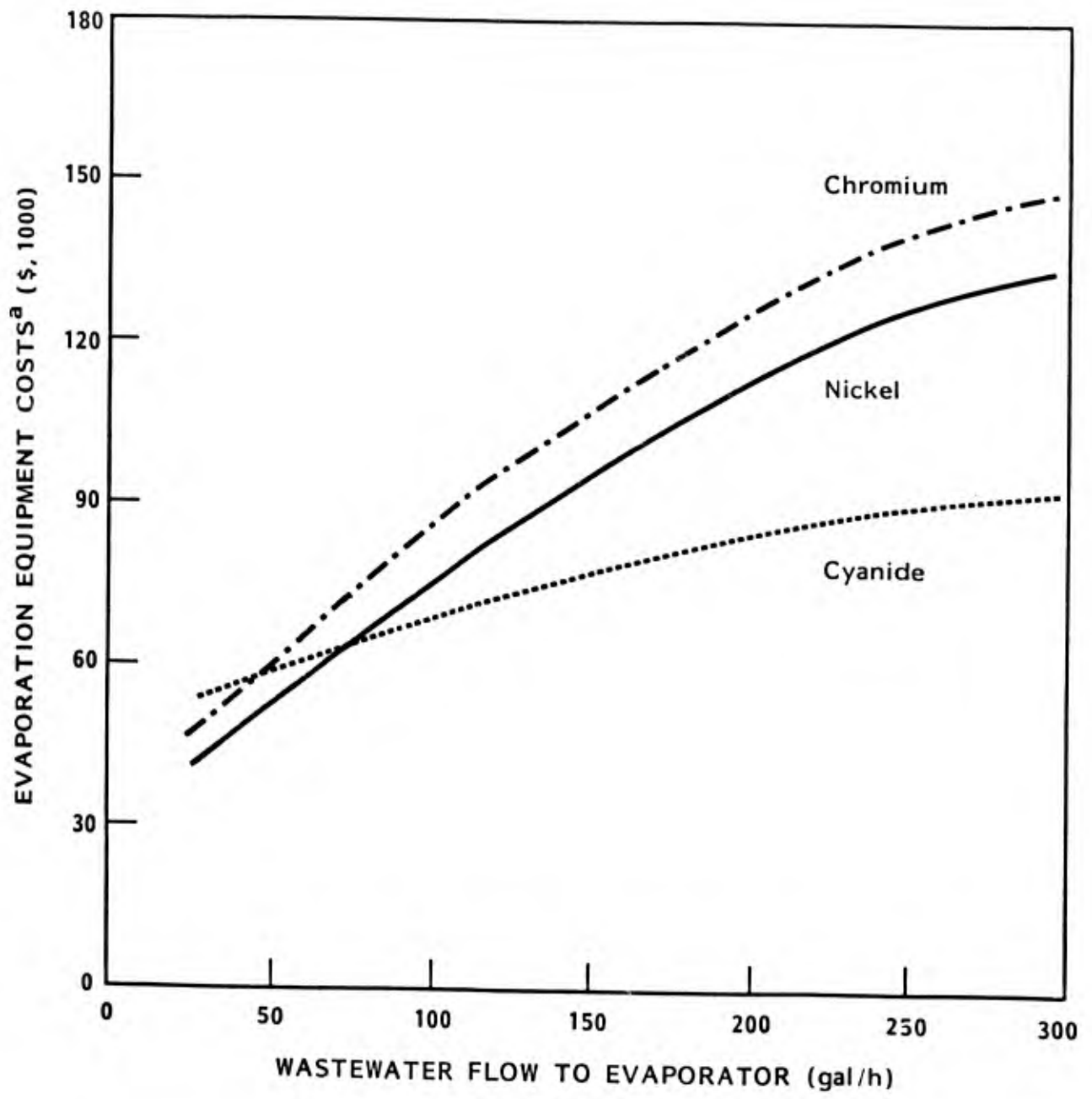

Figure 63. Capital Cost of Single-Effect Rising Film Evaporators

encased in a support structure. When the membranes are placed between two water solutions, the solvent will form a complex with a metal ion at one interface. In response to the concentration gradient that exists within the membrane, the complex will diffuse across the membrane (Reference 44).

Many potential applications are envisioned for coupled transport membrane systems. Copper, nickel, chromate, and other metals have been recovered from rinse solutions. The ability to extract the metal contained in fouled plating baths also has potential. Much of the development work has been performed and the results have been patented by Bend Research Corporation of Bend, Oregon. The EPA has subsidized research projects using the technology to control pollution from metal finishing processes.

## 2. Process Description

Coupled transport is a process for exchanging ions of interest from one aqueous solution into another. The exchange is coupled with the exchange of a second ion in the reverse direction. Consider the case of a coupled transport membrane separating chromate ions from a dilute aqueous solution of chromic acid at low pH and transporting them to a less acidic solution of sodium chromate. The microporous membrane contains an organic complexing agent for chromates, R. The mechanism is shown in Figure 64. At the chromic acid interface, the complexing agent forms a neutral complex with the chromate ( $(RH)_2 CrO_4$ ). This complex is soluble only in the organic solvent. It will then diffuse across the membrane to the other interface. When exposed to the higher pH of this interface, the complex will dissociate, freeing the chromate to the aqueous phase. The neutral organic complex, R, will then diffuse back across the membrane. Diffusion in both directions is powered by internal concentration gradients.

Such a process could be used to recover the chromate content of spent chromic acid solutions by enriching virgin chromate supplies. This particular reaction is co-transport, because no ion is being transferred across the membrane in the opposite direction to the chromate. The driving force of the reaction is the hydrogen ion gradient across the membrane.

In countertransport, shown in Figure 65, metal cations are removed from a dilute solution to a concentrated solution and the transport is balanced by a flow of hydrogen ions in the opposite direction.

The two examples show the potential for application of the process to enrich plating solutions. The process can extract metals across a concentration gradient of over a 1,000 to 1. The main areas of application in metal finishing appear to be chromate, copper, and nickel recovery.

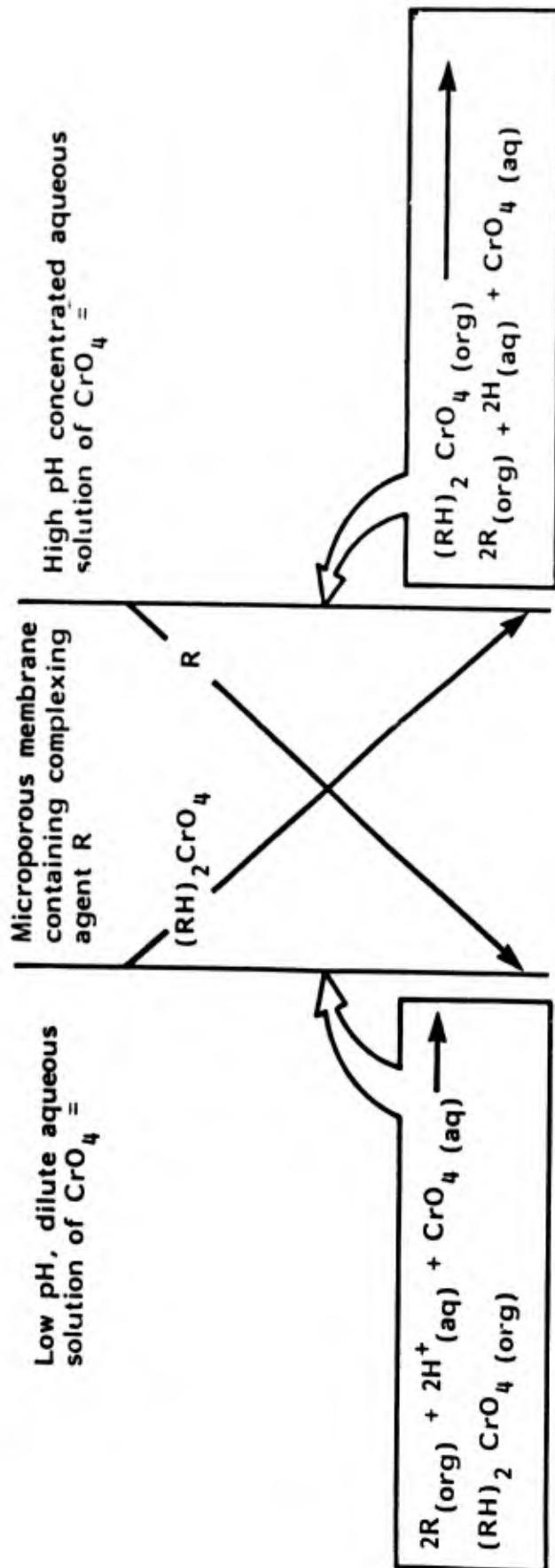

Figure 64. Chromate Recovery, Co-Transport

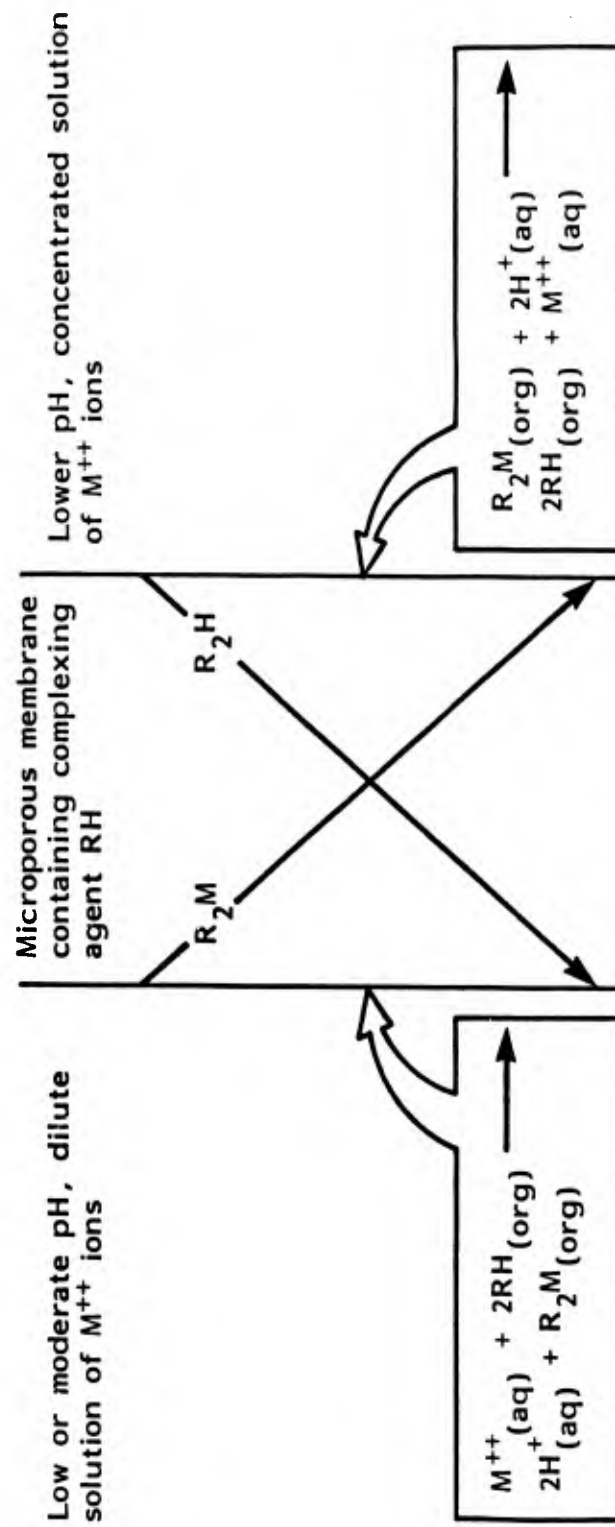

Figure 65. Metal Cation Recovery--Counter Transport

No cost data or operating requirements are available at this time. Applications of the process seem favorable because of the relative simplicity of the operation; that is, the process is driven by solution chemistry and needs no auxiliary utilities.

#### D. ELECTRODIALYSIS

##### 1. Summary and State of Technology Development

Electrodialysis is one of the more recent technologies applied to the recovery of plating chemicals from rinse solutions. Although the phenomenon was observed in the 1800s, it did not achieve any commercial application until durable, ion-selective membranes were developed in the 1950s. The first applications were for desalination of brackish water. The ion-selective membranes are essentially the same structure as ion exchange resins, except in sheet form. They are either anion-permeable or cation-permeable membranes.

In 1975, the first attempts were made to use electro-dialysis to reclaim plating chemicals from rinse solutions after plating baths. There are now more than 100 applications of the process on a variety of plating solutions. Three vendors are currently manufacturing systems. Cyanide baths (gold, cadmium, silver, and zinc) and nickel plating baths are the major areas of application. Other baths with successful applications of electro-dialysis are tin fluoroborate, tin-lead fluoroborate, and trivalent chromium baths. The application to hexavalent chromium plating is questioned because the oxidizing characteristic of the solution may degrade the membranes (Reference 45).

The units are sold as package systems and have been tested over sufficient time to have conquered most of the problems of an emerging technology. Still, as with any membrane technology, the potential exists to foul the membrane by solids in the unit feed or by precipitation of compounds within the cell.

##### 2. Process Description

Electrodialysis (ED) is a membrane process that can be used to remove ions from solution. This result is accomplished through ion exchange membranes under the influence of an electrical potential applied across the membrane. Cation membranes allow only cations, such as copper, nickel, and zinc, to pass through. Anion membranes allow only anions, such as sulfates, chlorides, or cyanides, to pass through. By alternately stacking these different membranes along with spacers to provide hydraulic channels, alternate concentrating and diluting channels can be created (Figure 66). The electrical potential will cause any ionizable compounds in the diluting cell to

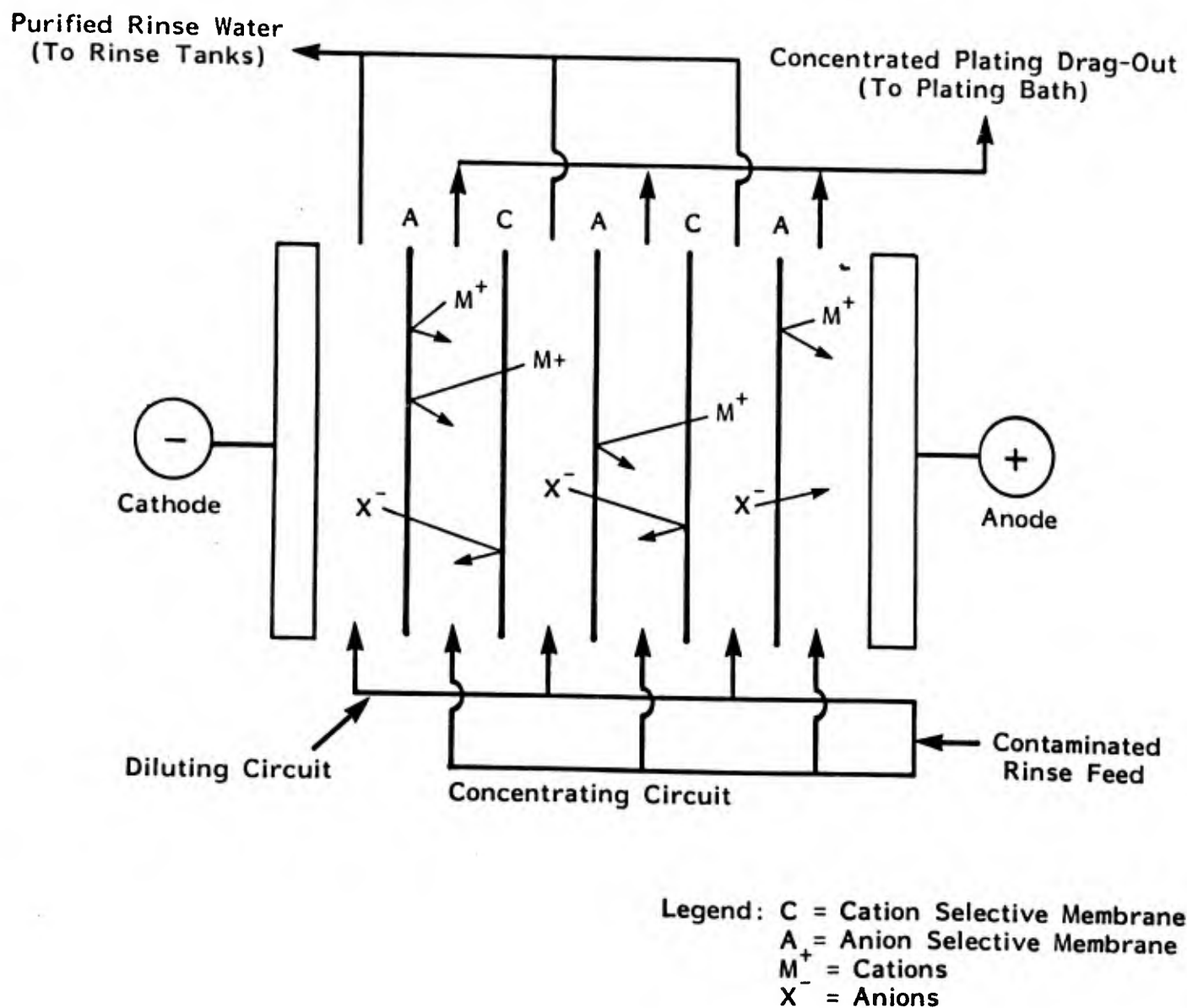

Figure 66. Electrolysis Unit Flow Schematic

migrate into the concentrating circuit. On the other hand, the membranes will not allow ions to leave the concentrating cell.

In a plating chemical recovery application, ED is used on a stagnant rinse, as in Figure 67. Solution from the stagnant rinse is continually pumped through the dilution circuit. The solution is pumped through the unit at a high rate to maintain turbulent flow in the cell. In this kind of configuration, the ion removal for each pass is in the range of 20 to 30 percent. The percent recovery of drag-out will be in the range of 90 to 95 percent.

The solution in the concentrating circuit can be either plating solution or a carrier solution that is blended back into the plating bath. Again, it is important to maintain turbulent flow conditions in the cell. A significant advantage of electro dialysis is that there is no maximum concentration limit on the solution in the concentrating cell. The only limit is based on the solubility of the compounds in the solution. This advantage over reverse osmosis and ion exchange is particularly significant in room temperature plating solution where surface evaporation does not provide opportunities to add solution to the baths.

There are further advantages of electro dialysis:

- The units operate continuously (ion exchange without regeneration).
- The only utility required for operation is a DC power source.
- The units are compact.
- Operating cost is low; electrical power consumption averages \$0.25/hour.

Disadvantages of the process vary, depending on application. All ionic species are nonselectively recovered. Consequently, bath impurities will also be recovered. Organic brighteners, wetting agents, and other nonionized compounds will accumulate in the stagnant rinse.

A potential problem with any application is in the possibility of exceeding the maximum voltage set by the solution conductivity at the membrane boundary layer. The consequence of this condition is electrolysis of water to hydrogen and hydroxide ions. The subsequent migration of hydrogen ions will raise the pH and precipitate metal hydroxides, which will foul the membranes (Reference 45). Vendor data are unclear as to whether safeguards are available to avoid this condition.

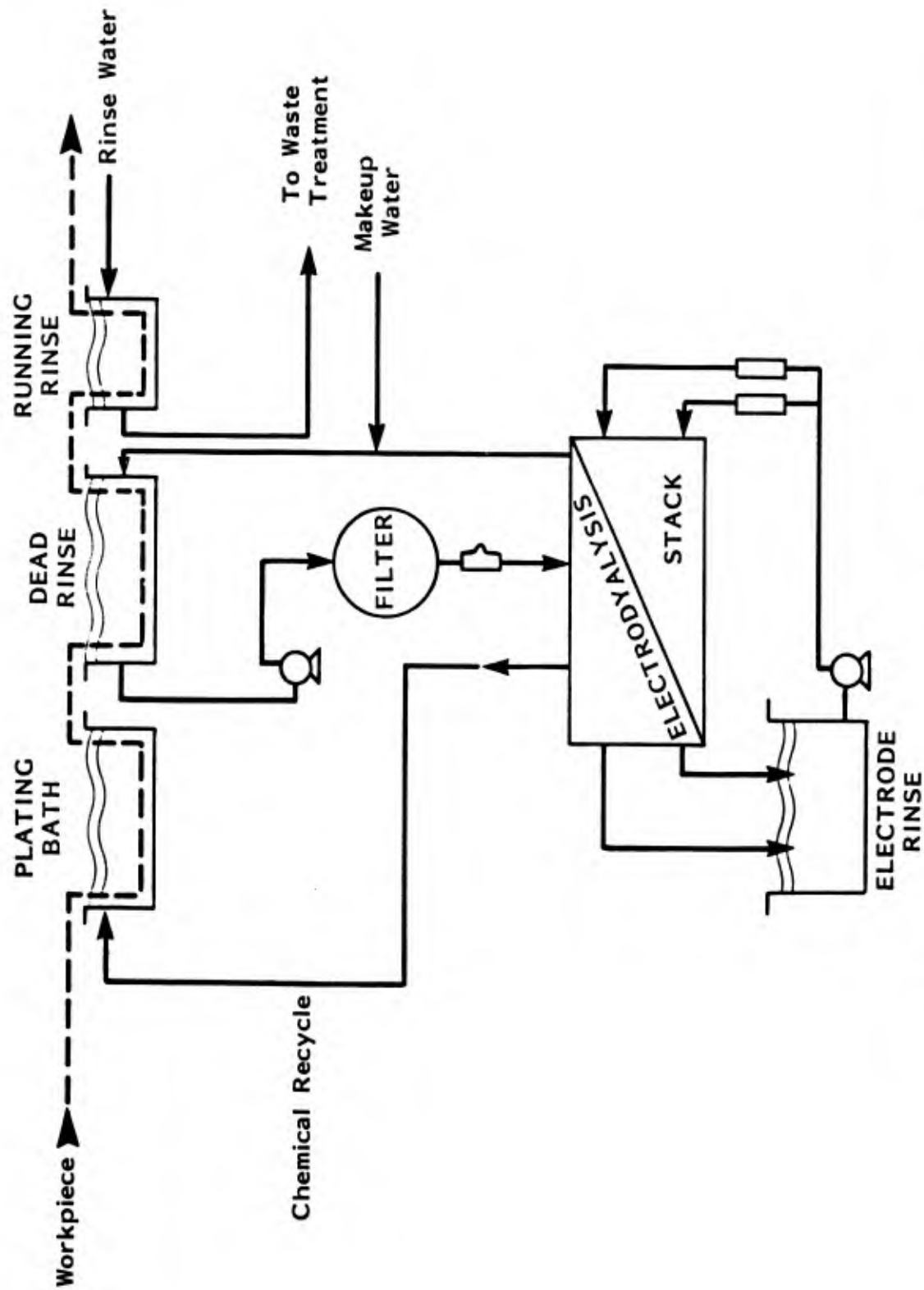

Figure 67. Electrodiagnosis Unit for Plating Drag-Out Recovery

### 3. Operation and Maintenance Requirements

The ED units, being continuous and requiring electricity as the only utility, should need minimum operator attention. It is important to screen any potential application thoroughly and ensure that required feed pretreatment is maintained rigorously to improve the probability of a trouble-free operation. In successful applications, ED has performed reliably over long periods of time.

Because ED will return contaminants to the plating bath, it will be necessary to implement scheduled plating bath purification treatments.

### 4. Residuals Generated

ED is applied solely as a plating chemical recovery process. The two effluents from the unit are a stream concentrated in the ionic compounds from the plating bath and partly purified rinse water. Both streams should be recycled.

### 5. Cost Factors

Costs for package system ED units range from \$30,000 to \$45,000. Each unit is complete with all internal pumps, piping, valves and necessary feed pretreatment. For any given application, unit cost depends upon the number of cell pairs in the ED stack. A cell pair is an anion selective/cation selective membrane pair. Units are available with from 10 to 100 cell pairs.

The justification for investment in the recovery unit is savings in costs of plating chemicals and waste treatment and reduction in costs of sludge disposal. Table 41 gives a cost-benefit analysis of the application of the unit to a cadmium cyanide plating process.

## E. REVERSE OSMOSIS

### 1. Summary and State of Technology Development

Reverse osmosis (RO) technology has been employed in the metal finishing industry to recover plating chemical from rinse water as well as to purify mixed wastewater for reuse. In plating chemical recovery applications, RO units separate the valuable metal salts from rinse solutions, yielding a concentrated metal solution that can be recycled to the plating bath, and water of sufficient purity for use in rinsing.

The attractive features of RO systems include: relatively low initial and operating costs compared with alternative separation processes, capability for continuous operation, simplicity of operation and maintenance, and minimal floor space requirements for system installation.

TABLE 41. EVALUATION OF ELECTRODIALYSIS RECOVERY FOR CADMIUM CYANIDE PLATING<sup>a</sup>

Item	Amount
Performance factors:	
Rinse tanks needed	2 (1 dead, 1 running)
Dead tank cadmium concentration (mg/l)	480
% recovery:	
Cadmium	96
Cyanide	96
Rinse rate (l/min):	
Dead tank	NA
Running	10
Running rinse cadmium concentration (mg/l)	15.
Cost factors:	
Unit cost (\$)	38,000
Installation cost (\$)	3,000
Operating cost (\$/yr) <sup>b</sup>	1,400
Cost savings (\$/yr):	
Cadmium	9,200
Cyanide	6,100
Treatment and solid waste savings	28,600
Annual operating saving (\$/yr) <sup>c</sup>	42,500
Return on investment (%) <sup>b</sup>	103
General:	
Return of impurities	Yes
Effluent cadmium in mixed wastewater at 100 l/min (mg/l)	1.5

<sup>a</sup>Drag-out is 20 l/hour at 12,000 mg Cd/l, 48,000 mg CN/l; 4,000 hour/yr.

<sup>b</sup>Does not include maintenance, labor, or membrane module replacement.

<sup>c</sup>Does not include costs for depreciation, labor, etc.

NOTE: NA = not applicable.

The RO process is designed to operate continuously. The RO membrane is enclosed in a pressure vessel and the feed stream enters the vessel under pressure, 400-800 lb/in<sup>2</sup> gauge, where it is separated into a purified permeate stream and a concentrate stream by selective permeation.

Three important parameters describe the performance of the RO process: recovery, flux, and rejection. Recovery is defined as the percentage of the feed that is converted to permeate. Flux is the rate at which the permeate passes through the membrane per unit of membrane surface area. Rejection is the ability of the membrane to restrict the passage of dissolved salts into the permeate, and is related to particular salt species.

Three types of RO membrane configurations are used in commercially available units: tubular, spiral wound, and hollow fiber. Tubular modules require considerable floor space and have relatively high capital costs. They are, therefore, not economically competitive with the other systems for most industrial applications. The spiral-wound and hollow-fiber modules have virtually identical cost-to-capacity ratios. Hollow-fiber modules require less space, while spiral-wound units are less easily plugged by suspended solids (Reference 46).

Three types of commercially available semipermeable membrane materials can be used in RO units operating in the electroplating and metal finishing industries. The membranes differ mainly in their chemical resistance. Each has specific advantages and disadvantages and is suitable for certain plating chemical recovery applications. The range of application is most frequently limited by the pH of the solution to be treated (Reference 46). Table 42 summarizes the characteristics of commercially available membranes.

One of the most significant operating problems common to all the membranes is gradual reduction in performance because of plugging by suspended solids. Another potential problem is associated with the precipitation of dissolved solids in the feed solution as it is concentrated in the RO unit. These problems underline the need for full investigation of any potential RO applications. With proper pretreatment (suspended solids filtration, oxidation, pH adjustment, and so forth), performance can be trouble-free and the RO units easily maintained. The membrane materials now available significantly increase the range of potential applications. Still, because of failures early in the technology development, the only area of significant application in the metal finishing industry is for concentration and recovery of drag-out from Watts nickel plating baths.

Table 42. Commercially Available Membrane Materials

Type	Description	Source	Allowable pH Range	Typical Operating Pressure (lb/in <sup>2</sup> gauge)	Flux Rate (gal/ft <sup>2</sup> -d) at 77°F & 400 lb/in <sup>2</sup>	Typical Flux Per Module (L/gal-d)	Module Replacement Cost (\$)
Hollow fiber	Hollow fine fiber asymmetric membranes or aromatic polyamide	E. I. DuPont Wilmington, DE	4-11	400-800	1.8	1,000	750
Spiral-wound cellulose acetate	Flat sheet composite membrane of cellulose acetate with mesh spacers, rolled into cartridge	Osmonics, Inc. Fluid Systems, Div. of UOP, Inc. Dow Chemical USA	2.5-7	400-800	28	1,500	350
RC-100	Flat sheet composite membrane of poly-ether/amide on polysulfone, rolled into cartridge	Fluid Systems, Div. of UOP, Inc.	1-12	400-800	13	1,000	1,000

## 2. Process Description and Performance Evaluation

### a. Plating Drag-Out Recovery Process

Separation of plating chemical drag-out from rinse solutions is well established and applied mainly to mild-pH nickel rinses. The initial membrane made commercially available, the cellulose acetate membrane, is well suited for this application.

More recent membrane developments widen the range of commercial applications. The polyamide membrane is durable up to a pH of 11.0 and is suitable for use on cyanide baths with a solution pH in this range. The polyether/amide membrane was offered commercially in 1977. It is reputed to be durable over a broad pH range (1-12), but the limited industrial applications thus far have not severely tested its durability. However, the membrane could significantly enhance the versatility of the RO process.

Advantages of RO over evaporation and ion exchange for chemical drag-out recovery include its lower operating cost and that electricity is the only utility needed for operation. The application of RO is limited because of the degree of metal salt concentration it can achieve and the level of permeate purity associated with treating concentrated feed streams.

Figure 68 shows a RO recovery system using a single RO module. Flow rates and concentrations in the figure are based on data compiled for the process during EPA-sponsored pilot evaluations. The system shown is termed "open-loop chemical recovery"; it does not totally eliminate the wastewater generated by this process (Stream 5, Figure 68).

The Walden Division of Abcor, Inc., conducted a series of experiments, sponsored by the Industrial Environmental Research Laboratory (IERL) of the U.S. Environmental Protection Agency (EPA), to evaluate the application of RO to plating chemical recovery. These experiments examined the performance and life of membranes that were commercially available at the time, as well as advanced membranes with promising applicability. Table 43 summarizes the tests that used commercially available membranes.

Table 44 gives a composite of case histories for applications of RO treatment of rinse water wastes. As the histories show, such systems are operating successfully on segregated rinses following plating baths such as bright nickel, Watts nickel, acid copper, copper cyanide, and acid zinc, in addition to purifying the mixed wastewater effluent from a

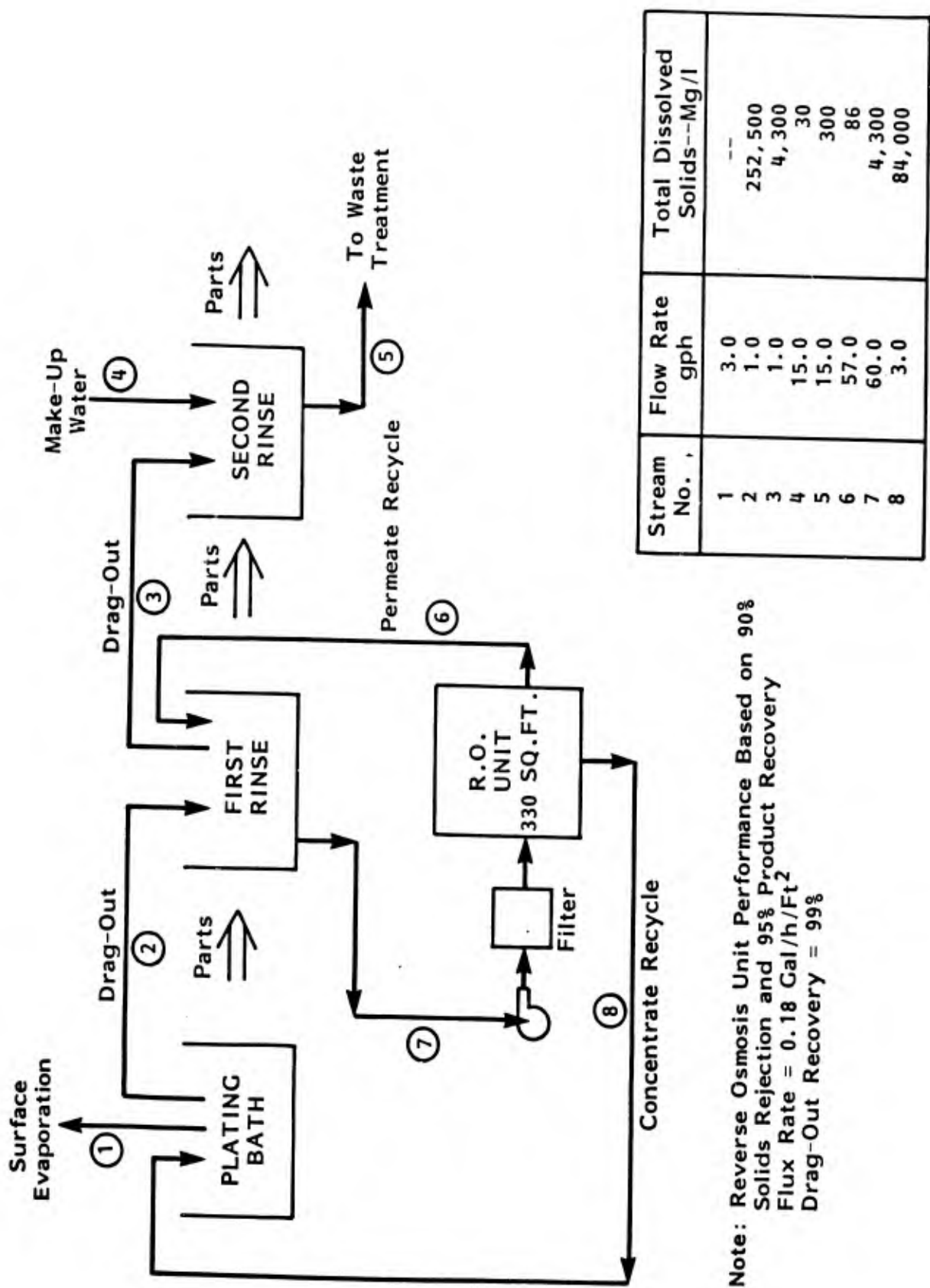

Note: Reverse Osmosis Unit Performance Based on 90%  
 Solids Rejection and 95% Product Recovery  
 Flux Rate = 0.18 Gal/h/Ft<sup>2</sup>  
 Drag-Out Recovery = 99%

Figure 68. Plating Dragout Recovery Using Reverse Osmosis

TABLE 43. EVALUATION OF EPA-SUPPORTED AND PRIVATE REVERSE OSMOSIS TESTS

Material	Type of Test		Overall Performance (good G, acceptable A, unacceptable U)
	Bath Chemical	Limitations	
Polyether/amide (PA-3000)	Copper cyanide	Laboratory performance & life test (500 h)	G
	Zinc cyanide	"	G
	Acid copper	"	A
	Chromic acid Zinc cyanide	" Field performance test (100 h)	G G
Polyamide (B-9)	Copper cyanide	"	A
	Zinc cyanide	"	A
Copper pyrophosphate		Short-term laboratory performance tests	G
Nickel sulfamate		"	G
Nickel fluoborate		"	A
Zinc chloride		"	A
Cadmium cyanide		"	G

TABLE 43. EVALUATION OF EPA-SUPPORTED AND PRIVATE REVERSE OSMOSIS TESTS  
(CONTINUED)

Material	Bath Chemical	Type of Test	Limitations	Details	Overall Performance (good G, acceptable A, unacceptable U)
	Zinc cyanide		pH must be <11.0 Need evaporation to close loop	"	G
	Copper cyanide Zinc cyanide		pH must be <11.0 pH must be <11.0 Need evaporation to close loop	" 800-h life test	G G
	Watts nickel		Boric acid selectively permeates membrane	Field performance test (1,190 h)	G
	Copper cyanide		pH must be <11.0	Field performance test (1,130 h)	G
	Copper cyanide			Field performance test	G
Cellulose acetate (tubular)	Acid copper		pH must be >2.5	Laboratory performance & life test (500 h)	U
"	Chromic acid		pH must be >2.5	"	U
(Spiral wound)	Copper pyrophosphate		pH must be >2.5	Short-term laboratory performance test	G
"	Nickel sulfamate		Boric acid selectively permeates membrane	"	G
(Tubular)	Nickel fluoborate		"	"	G
(Spiral wound)	Zinc chloride		pH must be >2.5 Need evaporation to close loop	"	A

**Table 44. Existing Demonstrated Commercial Application of Reverse Osmosis in the Metal Finishing Industry**

Plating Bath Chemical	Membrane Type-- Configuration	Application Operation Criteria	Operating Experience and Recommendations
Bright nickel	Cellulose acetate/ spiral wound	Closed-loop drag-out chemical recovery and purified rinse water recycle, feed water pretreatment consisting of prefiltration with diatomaceous earth precoat filter and/or micron cartridge filters. Conductivity, flowrates, pressure are monitored; pH (5-6) not adjusted before feed. Surface evaporation makeup with demineralized water. Plant startup November 1977.	Membrane life was a minimum of 18 months. Despite regular backflushing, there is a gradual fouling of membrane. Experienced corrosion inside carbon steel shell of pressure vessel. Vessel should be stainless steel, plastic, or fibreglass.
Watts nickel	Cellulose acetate/ spiral wound	Closed-loop drag-out chemical recovery and purified rinse water recycle, feed water pretreatment consisting of prefiltration with 10-15 $\mu$ m cartridge filters, pH adjustment to 4.0; conductivity, flowrates, pressure are monitored, water to replace surface evaporation losses is supplied by separate RO unit. Plant startup September 1979.	No sign of membrane fouling so far. Normal operating time is 15-24 h/d. Cumulative operating time since startup is 736 h. Replaces prefilters every 3-4 days. No problem of algae growth in rinse tanks
Acid copper	Polyamide/ hollow fiber	Open-loop purification of rinse water overflow from several combined rinses and recycle of rinse water to plating operation, concentrate is further treated for metal precipitation with lime. Pretreatment of feed consisting of prefiltration with 10 $\mu$ m cartridge filter followed by sand filter and 5 $\mu$ m cartridge filter. pH of feed adjusted to 3.0-3.5, flowrate, conductivity and pressure are monitored.	Experiencing approximately 12-18 months membrane life. Using citric acid buffered ammonium hydroxide to wash each stage once a week, further backflushing is done on each module every month. Average operating time is about 13 h/d. Maximum temperature is 95°F.
Acid zinc	Polyamide/ hollow fiber	Same as acid copper except pretreatment includes pH adjustment to 6.0 and addition of bactericide. Plant startup 1976.	Average operating time about 22 h/d.
Copper cyanide	Polyamide/ hollow fiber	Closed-loop drag-out chemical recovery and purified rinse water recycle, feed water pretreatment consisting of filtration with 10 $\mu$ m bag-type filter plus 1.2 $\mu$ m & 0.45 $\mu$ m cartridge filters in series, no pH adjustment required (pH=10.0-10.5), surface evaporation makeup with DI water. Plant startup November 1974.	Approximate membrane life is 5-1/2 yr. No backflushing done at all. Replaces pre-filters once per week on the average. Average operation 8 h/d, 5 d/w.
Bright nickel	Polyamide/ hollow fiber	Closed-loop drag-out chemical recovery and purified rinse water recycle, pretreatment is the same as copper cyanide unit above, no pH adjustment (pH=7.0), surface evaporation makeup with DI water. Plant startup March 1975.	Membrane life approximately 5 yrs. No back-flushing done. Replaces prefilters once per week. Average operation 8 h/d, 5 d/w.

Table 44. Existing Demonstrated Commercial Application of Reverse Osmosis in the Metal Finishing Industry (Continued)

Plating Bath Chemical	Membrane Type-- Configuration	Application Operation Criteria	Operating Experience and Recommendations
Acid copper	Polyamide/ hollow fiber	Open-loop purification of mixed rinse water overflow and recycle of purified rinse water to plating operations; reject containing mixed metal salts is further concentrated in solar evaporation ponds. Pretreatment of feed water consisting of filtration with diatomaceous earth filter followed by 5 $\mu$ m and 0.5 $\mu$ m cartridge filters. Ultra-violet sterilization and chemical pretreatment limits algae. pH adjustment before RO to 4.5-5.0. Flowrate, conductivity, pressure are monitored. Surface evaporation makeup is demineralized city water. Startup 1976.	Operation 11 h/d maximum. Bacteria and algae growth is a problem. Cleaning with formaldehyde is done daily to prevent fouling with bacteria or algae. Hypochlorite solution used every 2-3 months to control further algae growth.
Mixed waste heavy metals (Cu, Cr, etc.)	Cellulose acetate/ spiral wound	Purification of mixed wastewater effluent from primary treatment system and recycle of rinse water to plating operation. Reject is further concentrated in solar evaporation ponds. Pretreatment of feed water consisting of filtration in gravity filters, vacuum DE filters and 5 $\mu$ m cartridge filter, pH adjustment to 5-6 before RO feed. Designed for zero discharge to sewer. Plant startup March 1977.	Membrane life approximately 3 yr. Normal operation 16 h/d, 5 d/w, operation by one engineer per shift plus one laborer; no major problems.

conventional treatment process. Some units have been in operation since 1976. Typical membrane life has been reported as from 1 to 5 years, with 18 months being average.

#### b. Wastewater Purification/Recycle System

Reverse osmosis development was spurred by a need for a low-cost way of obtaining relatively pure water from brackish or saline water. Despite the similarity of applications, RO has not been significantly used to purify wastewater for reuse because the membrane durability was questionable. The potential for high acidity in metal finishing wastewater made this wastewater unsuitable for RO systems employing either a cellulose acetate or polyamide membrane. The polyether/amide membrane, however, is sufficiently durable and could lead to widespread use of the technology.

The advantages of RO for this application are clear. Low operating cost, continuous operation, and ease of installation make it attractive compared with ion exchange water purification systems. The economic incentives for water recycle systems are a reduction in water and sewer use fees and in the volume of waste that must be processed by conventional end-of-pipe treatment. Similarly, platers that can reduce the volume of water going into Publicly Owned Treatment Works (POTW) to less than 10,000 gal/d may be regulated only on the concentration of cadmium, lead, and cyanide in the discharge.

The major concern associated with mixed wastewater purification is fouling of the membranes by precipitation products or suspended solids. Effective removal of suspended solids in the feed stream can be achieved by adequate upstream filtration. The danger of precipitation of salts in the concentrate stream must also be considered. With a variable composition typical of mixed wastes, pretreatment may be required to ensure that all solids remain soluble during concentration.

Figure 69 shows an RO mixed wastewater recycle system including the process elements and performance parameters. Data from EPA-sponsored testing were used to specify equipment size and define the unit's performance. Purification and recycle of water does not eliminate the need for waste treatment. As Figure 69 shows, however, the volume of waste is sufficiently reduced to make the use of a small batch waste treatment system feasible.

### 3. Operating and Maintenance Requirements

The attractive feature about RO systems, if the application is well suited, is their inherent simplicity. The

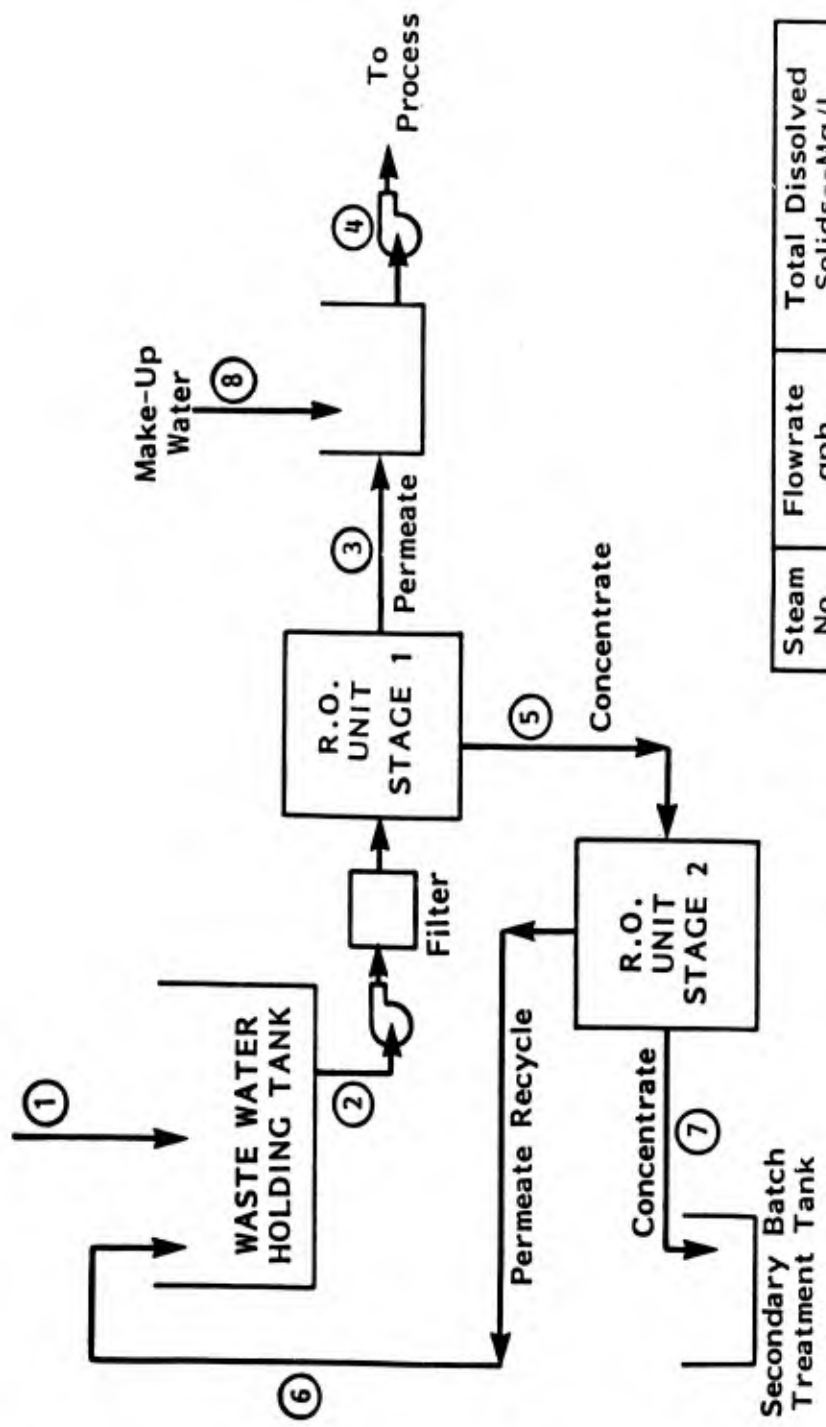

Notes: Stage 1 R.O. Unit--Solids Rejection = 95%  
 Product Recovery = 90%  
 Stage 2 R.O. Unit--Solids Rejection = 90%  
 Product Recovery = 90%  
 Purified Rinse Water Savings = 1365 Gal/h  
 Based on 99% Recycle

Steam No.	Flowrate gph	Total Dissolved Solids--Mg/l
1	1365	1,004.5
2	1500	1,000
3	1350	50
4	1365	50
5	150	9,550
6	135	955
7	15	86,900
8	15	30

Figure 69. Mixed Waste Water Recycle Via Reverse Osmosis

unit is plugged in and turned on; the only utility needed is electricity. If the application is not well suited, however, poor performance, low throughput, and high levels of solids in the permeate can render a system useless.

Regularly scheduled maintenance may include periodic changing of prefilter cartridges and periodic backflushing and chemical cleaning of the RO membranes. No sophisticated skills are required for these functions.

#### 4. Cost Factors

Capital costs for RO systems are primarily a function of the membrane surface area needed to satisfy the flow requirements of the particular application. The preengineered, package RO systems contain a set number of membrane modules along with a feed pump, prefilters, and other necessary auxiliaries sized for that application. Because the membranes are supplied in modules, they are easily replaced in the event of failure and the system can be expanded if processing requirements increase. Installation costs are minimal because the units are normally skid-mounted and require only utility connections. Figure 70 illustrates the relationship between equipment cost and membrane surface area for a design using spiral-wound cellulose acetate membranes.

The operating cost of an RO system is one of the most attractive features of the technology. The only utility needed to power the system is electricity and the feed pumps generally draw less than 1 kilowatt of power. Also, the units are automated and should only require attention for scheduled maintenance. Additional costs may be incurred, however, for membrane replacement and feed pretreatment (for example, filter cartridges, diatomaceous earth, and treatment chemicals).

#### 5. Cost/Benefit Analysis for Chemical Recovery Applications

The justification for installing RO systems to reclaim plating chemical drag-out includes: reduced cost for plating chemicals and water, reduced costs for wastewater treatment, and reduced volumes of solid waste for disposal. In addition, the installation of chemical recovery systems can significantly reduce the volume of wastewater that requires end-of-pipe treatment. Consequently, a smaller, less expensive end-of-pipe system is required.

The major factor in the justification of a drag-out recovery system, whether that system uses RO, evaporation, or other competing processes, is the quantity of chemical drag-out that can be recovered. Figure 71 relates the potential savings to the drag-out rate for a Watts nickel plating bath.

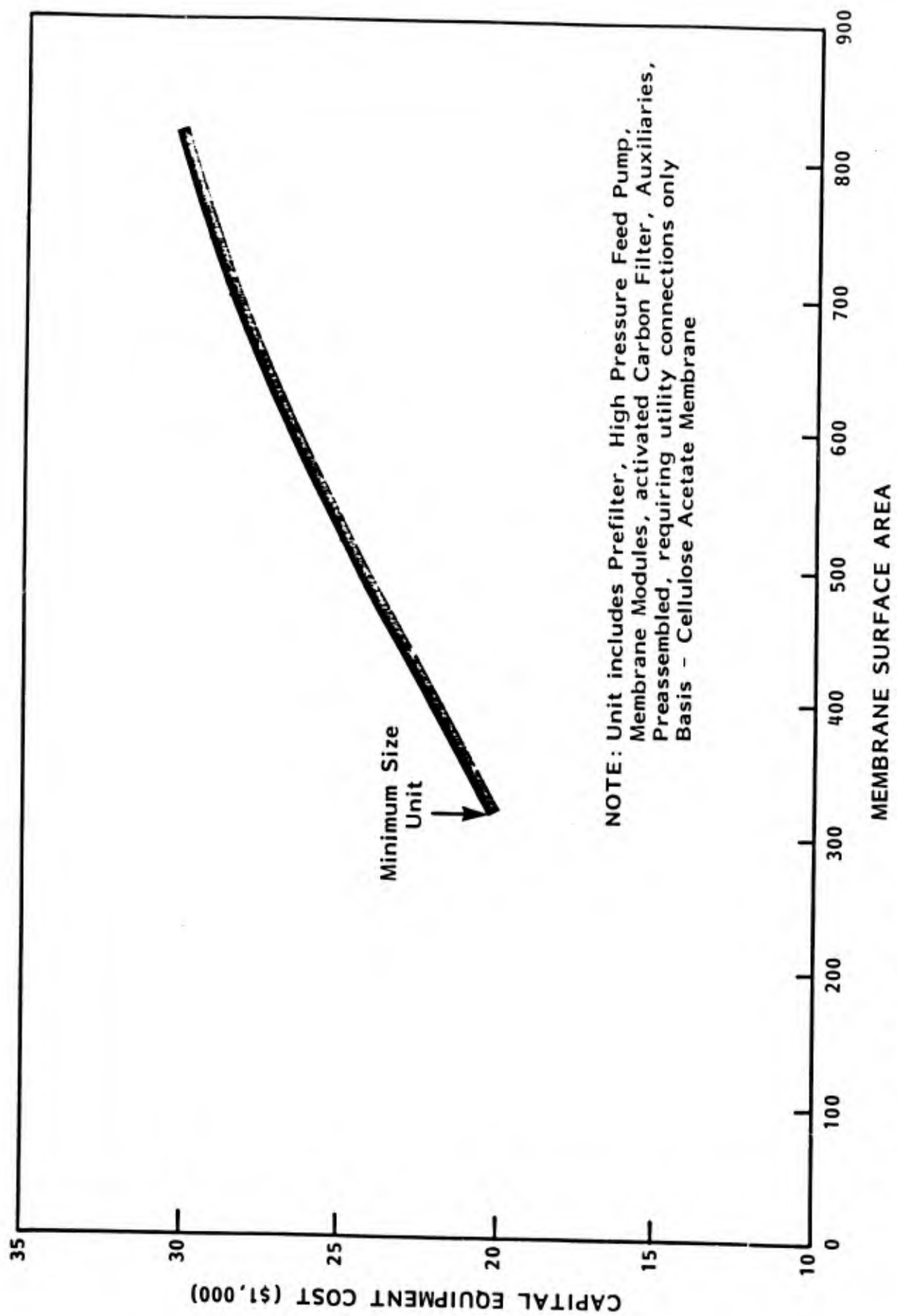
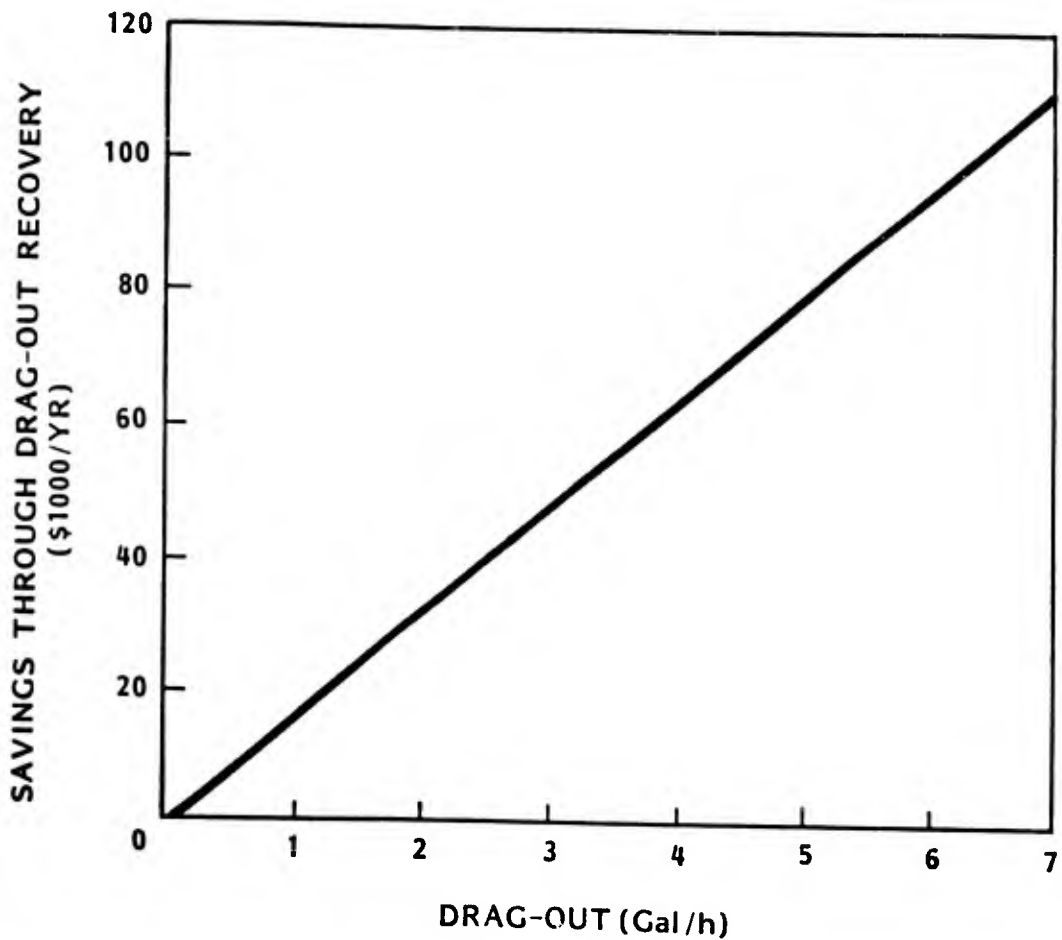

Figure 70 . Reverse Osmosis System Capital Cost vs. Membrane Surface Area



**Basis: 4000 hours per year Operation on Watts Nickel Plating line Rinse Tank**  
**Assume 90% Overall Drag-Out Recovery; Savings Based on Chemical Recovery Plus Reduced Pollution Control Costs.**

Bath Composition--	NiSO <sub>4</sub>	44 oz/gal	@	\$1.30/lb
	NiCl <sub>2</sub>	6 oz/gal	@	\$1.75/lb
	H <sub>3</sub> BO <sub>3</sub>	5 oz/gal	@	\$0.45/lb

**Figure 71. Annual Savings from Nickel Plating Drag-Out Recovery**

The value of the chemicals shown in Figure 71 includes their replacement cost plus the cost for removal from the wastewater and disposal of the solid waste. As an example, purchasing anhydrous nickel sulfate at \$0.80 plus removing it from the wastewater and disposing of the resulting sludge, assumed at \$0.50/pound, would mean \$1.30 saved for each pound of nickel sulfate drag-out recovered.

An analysis of the economics of an RO installation for drag-out recovery from the rinse tanks at an actual bright nickel plating line is given in Table 45. Current costs (1983) were used for the equipment originally installed at this shop. The life of the membrane modules was assumed to be 2 years.

Operating costs included labor and maintenance, plant overhead, raw material replacement costs and electricity (at \$0.045/kWh). Annual savings were based on reported plating chemical savings of 4 lb/h nickel salts and 1.5 oz/h of brightener, and water and sewer charge savings of \$0.80 per 1,000 gallons.

Depreciation of equipment was assumed to be straight line over a 10-year equipment life. As shown in Table 45, the average return on investment is 27 percent and the payback period is 2.7 years.

## F. ELECTROLYTIC CELL PROCESSES

### 1. Summary and State of Technology Development

The electrolytic cell is the basic device used in the electroplating of metals and has been so used since the birth of the plating industry. Recently, with the advent of pollution control and emphasis on material conservation, it has found other uses in the plating shop. This section will deal with electrolytic cells that do not use a membrane; electrodialysis and ion transport membranes are systems that combine an electric potential and membranes to effect a separation. The use of electrolytic cells has been demonstrated for (Reference 47):

- Plating of metals from a plating rinse onto a conventional metal cathode (electrowinning)
- Treatment of cyanide plating rinse with simultaneous plating of metals onto a cathode and oxidation of cyanide at the anode
- Oxidation of cyanide contained in waste process solutions (electrolysis)

TABLE 45. ECONOMICS OF REVERSE OSMOSIS SYSTEM FOR NICKEL SALT RECOVERY, OPERATING 4,000 h/yr

Item	Amount
Installed cost, 550-Ft <sup>2</sup> unit (\$):	
Equipment:	
RO system including 25- $\mu$ m filter, pump less 10 membrane units	17,000
Activated carbon filter	2,000
Auxiliaries, piping, and miscellaneous	3,000
Subtotal	<u>22,000</u>
Installation, labor and material	3,000
Total installed cost	<u>25,000</u>
Annual operating cost (\$/yr):	
Labor and maintenance at \$10/h	1,600
General plant overhead	1,000
Raw materials:	
Module replacement, 2-yr life (10 x \$350/module) x 0.5 yr	1,800
Resin for carbon filter	500
Prefilter element (25- $\mu$ m)	700
Electricity costs (\$0.45/kWh)	<u>1,100</u>
Total operating cost	6,700
Annual fixed costs (\$/yr):	
Depreciation, 10% of investment	2,500
Taxes and insurance, 2% of investment	500
Total fixed costs	<u>3,000</u>
Total cost of operation	9,700
Annual savings (\$/yr):	
Plating chemicals:	
4 lb/h nickel-salt at \$1/lb	16,000
1.5 oz/h brightener at \$0.10/oz	600
Water and sewer charges: saving 270 gal/h at \$0.80/1,000 gal	900
Total gross annual savings	<u>17,500</u>
Net savings = annual savings (operating cost + fixed cost) (\$/yr)	7,800
Net savings after taxes, 45% tax rate, $7,800 \times 0.55 + 2,500^a$ (\$/yr)	6,800
Average ROI = net savings after taxes/total installed investment x 100 (%)	27
Cash flow from investment = net savings after taxes + depreciation (\$/yr)	9,300
Payback period = total installed investment/cash flow (yr)	<u>2.7</u>

<sup>a</sup>10% investment tax credit = \$2,500 (or 0.10 x 25,000).

- Recovery of metal content from spent plating solutions

Various types of equipment are used in electrolytic recovery systems. The basic type of unit employs flat plate cathodes and anodes in an agitated tank. The metal in solution plates onto the cathode and the deposit is removed as a strip when it reaches a certain thickness. The strip is usually sold to a metal reclaimer.

High surface area cathodes are used in a patented device by HSA Reactors. The firm employs a fiber cathode that provides a large surface area per unit volume; the metal is removed from the cathode by reversal of the current or rinsing of the cathode with a stripping solution. The concentrated stripping solution can be returned to the plating bath. The high surface area makes recovery of metals from dilute solutions more feasible.

The most significant way in which electrolytic processes differ from other recovery schemes is that they recover only the metal; all other separation processes recover some other compounds in addition to the metal. Depending on the application, this difference can be viewed as either an advantage or disadvantage.

## 2. Process Description

a. Electrowinning. Conventional electrolytic cells have been used to recover metals from rinse solutions by use of a recirculated rinse that washes the drag-out from the workpiece and provides the feed to the recovery unit. The system is illustrated in Figure 72. The metal is plated on to the standard plate cathodes (usually stainless steel) and stripped off when it reaches a certain thickness.

Factors that influence the rate of metal deposition are (Reference 47):

- Cathode area
- Agitation rate
- Solution chemistry
- Temperature

The cathode surface area depends on the size and number of the cathodes employed in the unit. The agitation rate, average metal concentration in the rinse solution, solution conductivity and temperature all influence the current

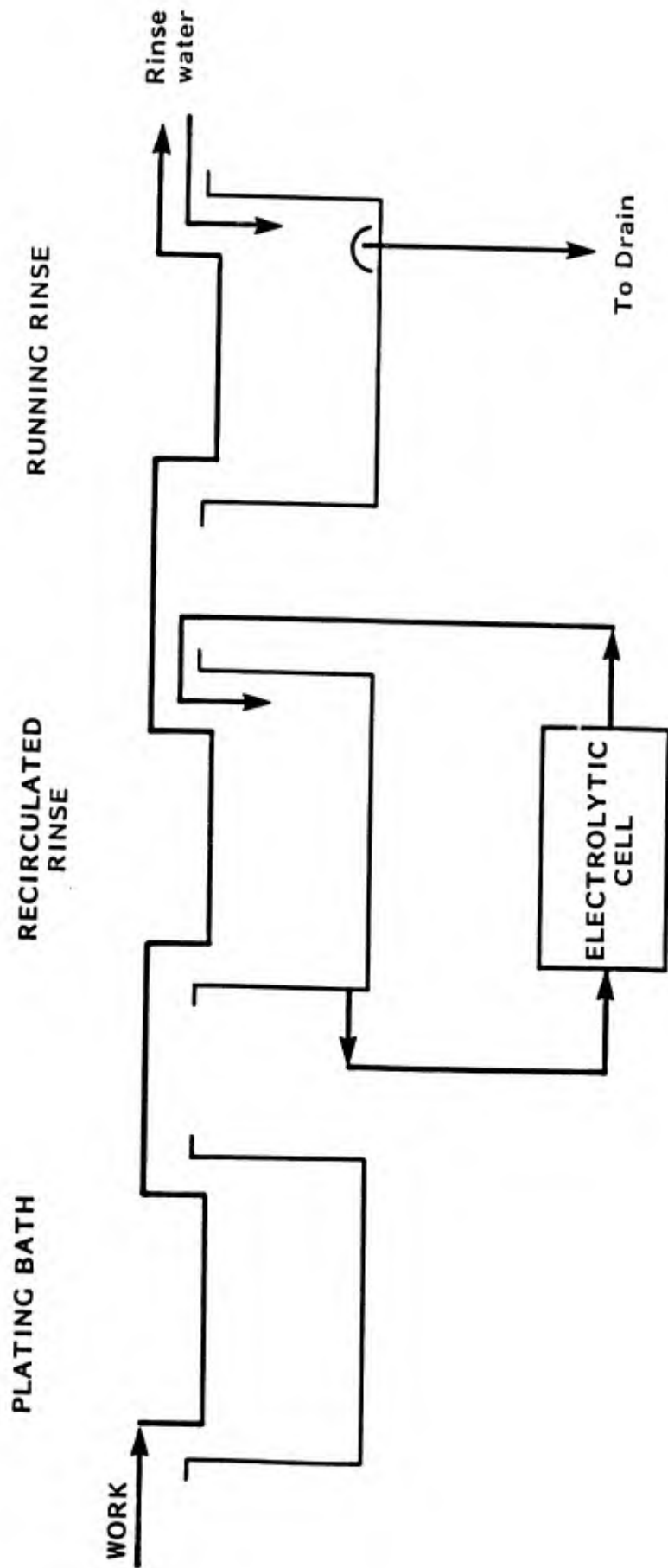

Figure 72. Drag-out Recovery From a Recirculated Rinse

density that can be maintained and still result in an even, homogeneous metal deposit on the cathode. The higher the current density allowed, the higher the rate of metal deposition per unit area of cathode.

Commercially available package units are available employing from 1 ft<sup>2</sup> to 100 ft<sup>2</sup> of cathode surface area. Use of a recirculated rinse, as shown in Figure 72, allows the conductivity of the solution to be controlled by the addition of electrolytes. The recirculated solution can also be maintained at a higher temperature in an efficient manner.

The more noble the metal in solution, the more amenable it is to electrowinning from solution. The early applications of the process were for gold and silver recovery. With adequate agitation, solution conductivity, and temperature, gold can be removed from solution to as low as 10 ppm. With less noble metals, such as copper and tin, a concentration in the range of 2 to 10 g/L is required for a homogenous metal deposit. Applications of electrowinning that have been successfully demonstrated in commercial operations include (Reference 45):

- Recovery of gold from acid and alkaline plating rinse solutions
- Recovery of silver from cyanide and thiosulfate plating rinse solutions
- Recovery of tin from plating rinses following alkaline, sulfate, and fluoro-borate plating
- Recovery of copper from plating rinses following acid copper plating baths and recovery of copper from copper etch and pickling solutions

b. High Surface Area Cathodes. The limitation of the amount of cathode surface area that could be economically justified in standard, flat-plate cathodes units lead to the development of electrolytic cells that employ a metal fiber cathode. These units have demonstrated the ability to remove less noble metals, such as copper and cadmium, from recirculated rinses to concentrations in the range of 10 to 50 mg/l. These concentrations are orders of magnitude lower than the 2 to 5 g/l equilibrium concentration achieved by standard flat-plate units. The advantage of the lower equilibrium concentration maintained is two fold; first the percentage of material recovery is

increased and, second, the free rinse after the recovery rinse (refer to Figure 72) is normally sufficiently dilute to be sewered without treatment.

The high-surface area unit commercially available is a patented device developed by HSA Reactors. Its application has thus far been limited to cyanide plating rinses after cadmium, copper, zinc, and brass plating baths. The unit removes the metal to low concentrations and also oxidizes the cyanide in the rinse water. It uses a standard flat plate anode. Cyanide oxidation is accomplished primarily by the addition of sodium chloride electrolyte to the rinse; the chloride ions are oxidized to chlorine at the anode and react with cyanide in the rinse. The performance of the unit in terms of both cadmium recovery and cyanide oxidation is shown in Figure 73. The cyclical variation in concentrations is a result of the work flow through the rinse. The cadmium concentration is reduced from 12,000 mg/l in the plating bath to an average of 30 mg/l in the rinse. The cyanide content is reduced from 65,000 mg/l in the plating bath to 3,500 mg/l in the rinse. Although this concentration represents a 95 percent removal, it could still result in cyanide contamination of rinse water in the free rinse. This problem could be eliminated by addition of a low rate of sodium hypochlorite to the rinse solution.

The fiber cathode is regenerated by passage of a strip solution through the unit and reversal of the current. Often plating solution can be used as the strip solution and, after being enriched, returned to the plating bath. The use of plating solution for stripping is advantageous for cyanide baths that are operated at room temperature and do not lose volume owing to surface evaporation.

c. Electrolysis of Cyanides. The use of electrolysis to oxidize concentrated cyanide solutions is a common practice and is less expensive than conventional alkaline chlorination at concentrations above 500 mg/l. Normally, the spent cyanide solutions used for stripping, descaling, and other surface treatments are treated in a bath by anodic oxidation over a 1- or 2-day period.

The temperature of the bath is usually maintained above 125°F and sodium chloride is added to speed up the reaction and improve current efficiency. When the residual cyanide content is reduced to 200 to 500 mg/l, the solution is sewered to alkaline chlorination treatment.

### 3. Operation and Maintenance Requirements and System Performance

Among other attractive features of electrolytic units, basically they constitute a plating process and, therefore, are understood by persons in a plating facility; moreover electricity is the only utility needed. The systems come complete with

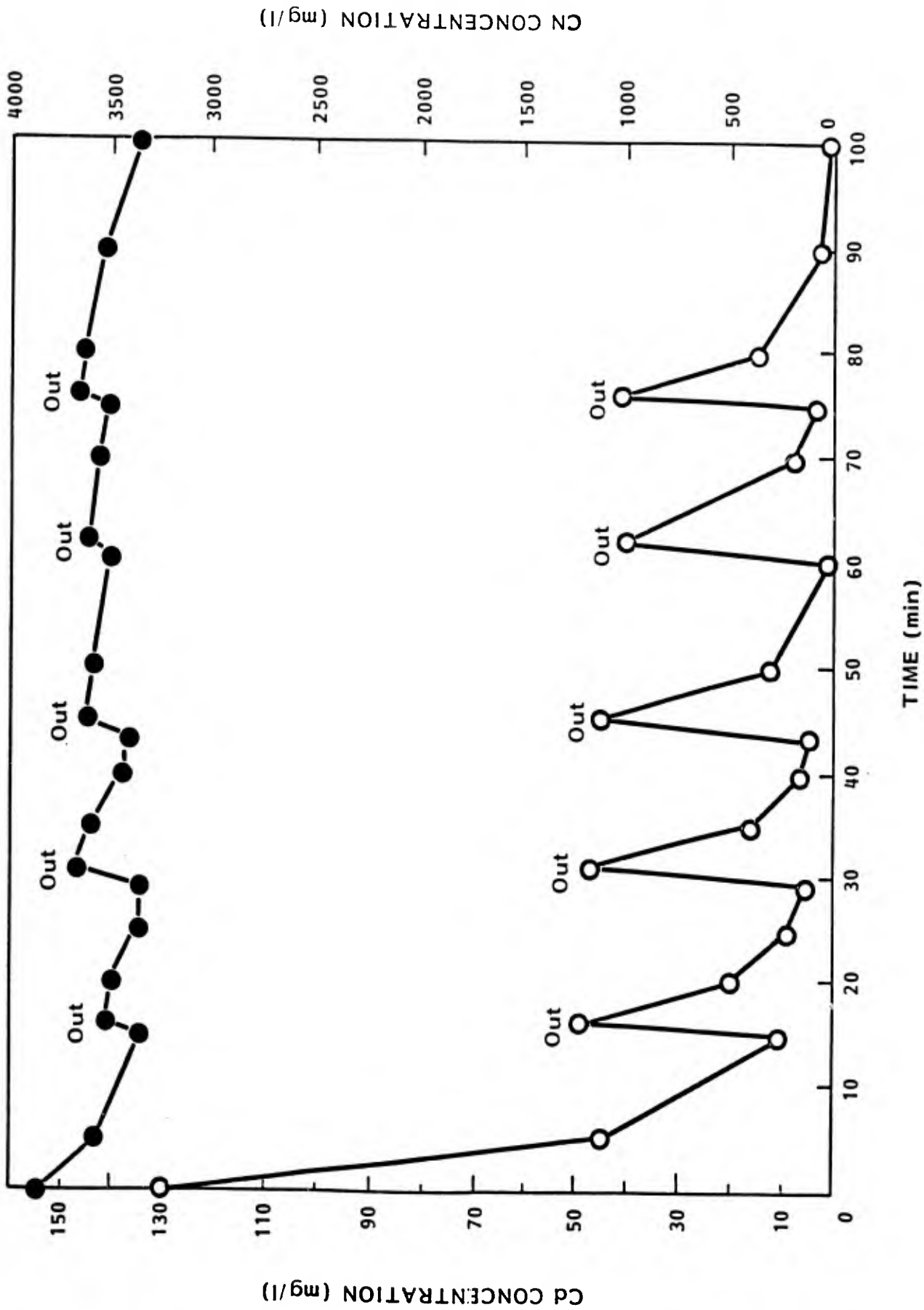

Figure 73. Cadmium and Cyanide Concentration (mg/l) in Recirculated Rinse vs. Time (min)

pumps, filters, rectifiers, and current density controllers that must be maintained by the operating personnel.

In a standard electrowinning recovery unit, the system is operated until the metal deposit thickness reaches approximately 1/4 to 1/2 inch. At this time the cathodes are removed from the recovery tank, the metal deposits are removed and the cathodes are replaced in the unit.

The high-surface-area units marketed by HSA Reactors come equipped with a microprocessor control/monitor logic package. Besides monitoring the unit for any abnormal conditions, the controller automatically initiates regeneration of the cathode after a preset operating cycle time.

Information from facilities using both types of electrolytic recovery units indicated the units are mechanically reliable, achieve rated capacity, and require minimal operator attention.

#### 4. Residuals Generated

The standard, flat-plate cathode electrolytic system recovers metals in the form of metal strips 1/4 to 1/2 inch thick. These strips can be either recycled internally if a melt foundry is used to fabricate parts or sold to a metal reclaimer.

The high-surface area unit regenerates a strip solution that can be recycled to the plating bath. The only limitation on the concentration strength of the recovered solution is the solubility limit of the metal in the strip solution.

#### 5. Cost Factors

Standard electrowinning units are available in package units with from 1 ft<sup>2</sup> to 100 ft<sup>2</sup> of cathode surface area. Larger, special order units are also available. The package units come complete with reactor tank, copper bussing, cathodes, anodes, recirculation pump, current controller, and rectifier. All internal piping and valves are also provided. The costs range from approximately \$5,000 for a 1 ft<sup>2</sup> unit to \$60,000 for a 100 ft<sup>2</sup> unit.

The capacity requirement depends on the amount of metal to be recovered. An example of the sizing calculation can be given based on data provided for copper recovery with the ERC/Lancy recovery unit. Figure 74 shows the maximum current density that can be used as a function of copper concentration over a range of solution temperatures; for example, at 10 g/l of copper and 140°F temperature, the maximum current density is 25 A/ft<sup>2</sup>. Figure 75 shows the cathode deposition rate as a function of current density; at 25 A/ft<sup>2</sup>, the deposition rate is 0.06 lb/hour-ft<sup>2</sup>. Drag-out recovery from a plating bath at 90 g/L of copper would equal 88 percent if the recovery rinse

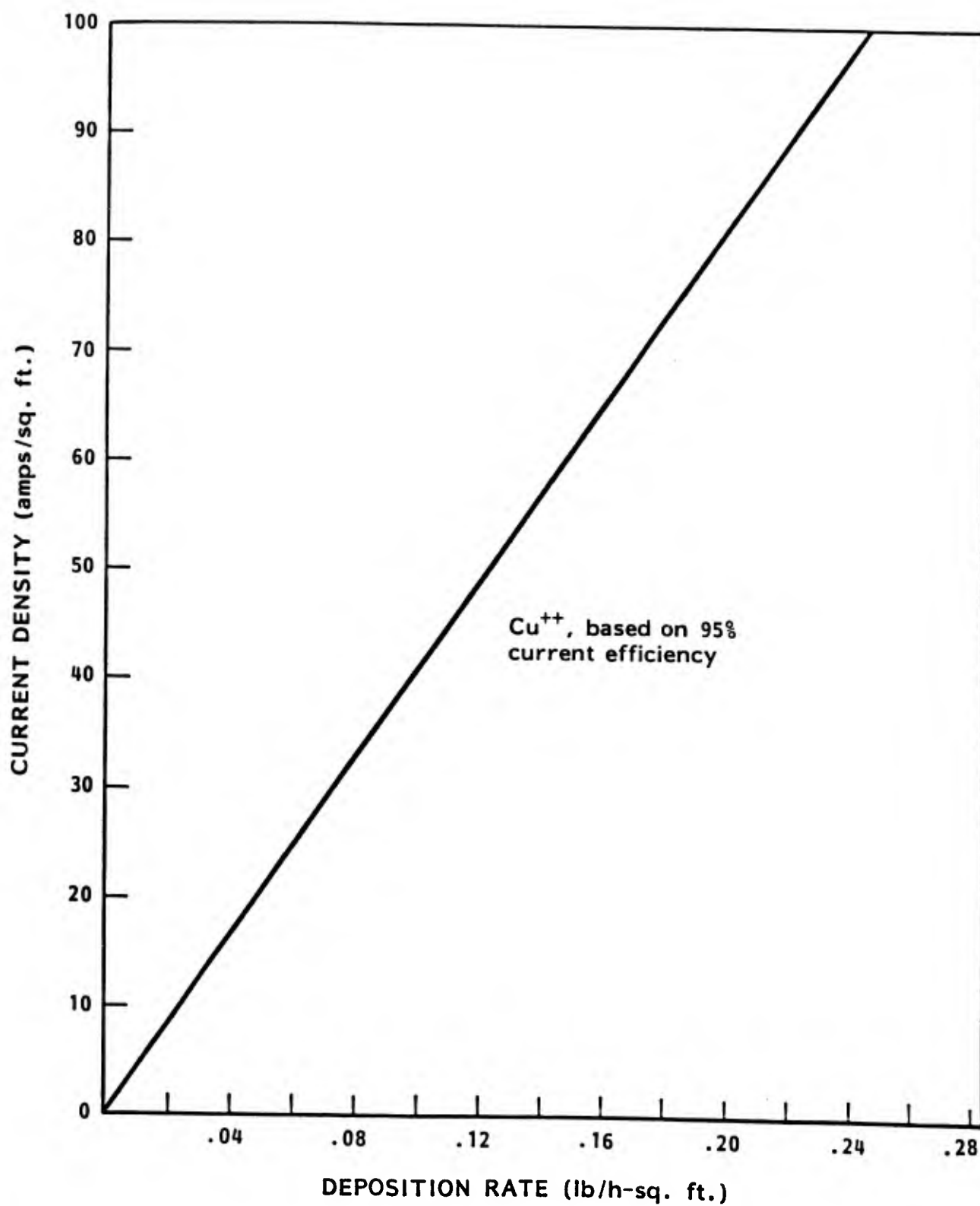

Courtesy of ERC/LANCY

Figure 74. Maximum Current Density for Copper Electrowinning

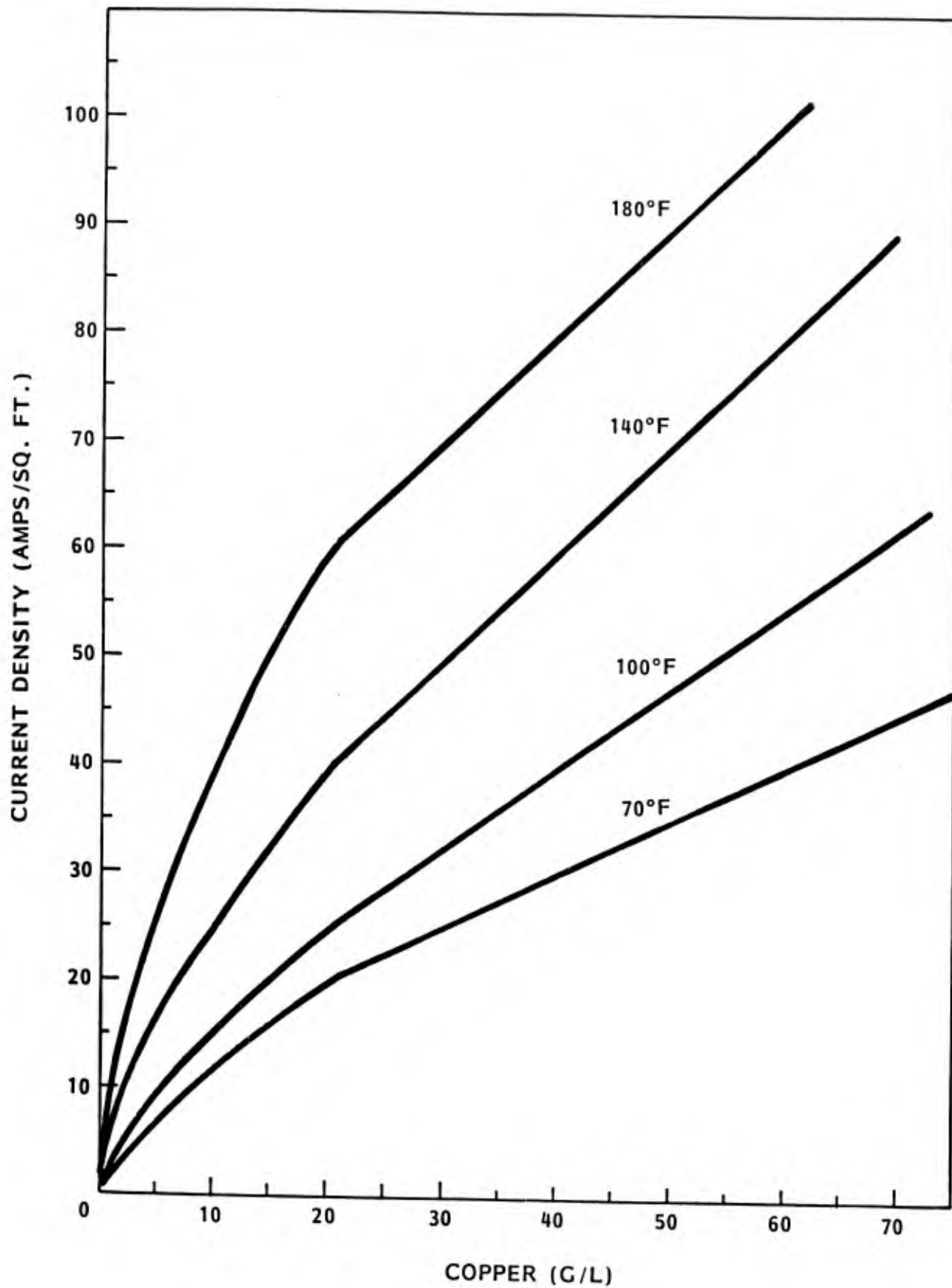

Courtesy of ERC/LANCY

Figure 75. Copper Deposition Rate as a Function of Current Density and Temperature

were maintained at 10 g/l. If the drag-out rate is 1 lb/hour of copper, the required cathode surface area would be  $(0.88 \text{ lb/hour}) / (0.06 \text{ lb/hour-ft}^2)$ , or equal to 15 ft<sup>2</sup>.

Table 46 gives an analysis of the recovery system in terms of installation and operating costs, economic benefits, and return on investment for the foregoing example. In the case of this application, the value of the copper is not sufficient to provide clear justification for the investment.

The high surface area electrode systems also come in modular units with from one to four electrode modules per unit. Total installed costs for the units are: one module, \$49,000; two modules, \$67,000; four modules, \$98,000.

The only utility costs are for electricity; operating and maintenance labor costs should be minor because the units are automatic with microprocessor-based controllers.

The capacity of the reactors is based on depositing 5 pounds of metal per module before it is necessary to regenerate. Regeneration takes approximately 2 hours, during which time the metal concentration builds up in the recovery rinse. Normally, the recovery rinse has a large enough volume that no significant loss of metal is experienced. The minimum (on-stream plus regeneration) cycle time is 6 hours. Based on these data, a plating process with a drag-out rate of 1 lb/hour of metal would drag-out 6 pounds during a 6-hour cycle; this process would require 1.2 modules if each module would recover 5 pounds of metal per cycle. In actual practice, the 2-module unit would be specified and the unit would be operated on an 8-10-hour cycle.

Buildup of metal in the recovery rinse during regeneration can also be determined. Assuming the recovery rinse had a volume of 800 gallons, and the concentration at the onset of regeneration was 30 mg/l cadmium. During the 2-hour regeneration cycle, 2 pounds of cadmium would be added to the rinse solution. The cadmium concentration would rise from 30 mg/l to 330 mg/l. Still, as the normal plating bath cadmium concentration is 12,000 mg/l, recovery would have declined from above 99 to 97 percent at the end of the regeneration. Table 47 gives the cost evaluation of this application based on an 8-hour cycle.

## G. DONNAN DIALYSIS

### 1. Summary and State of Technology Development

Donnan dialysis is an ion exchange membrane technology that relies on concentration gradients rather than pressure to transport ionic species across the membrane. Research reports have described cation exchange membranes to remove metal ions and anion exchange membranes to remove metal cyanide complex

TABLE 46. ELECTROLYTIC RECOVERY UNIT FOR  
ACID COPPER PLATING

Item	Amount
<b>Performance factors:</b>	
Rinse tanks needed	2 (1 dead, 1 running)
Dead tank copper concentration (mg/l)	10
% copper recovery	88
Running rinse copper concentration (mg/l)	100
Running rinse rate (l/min)	8
<b>Cost factors:</b>	
Unit cost (\$)	21,000
Installation cost (\$)	3,000
Operating cost (\$/yr) <sup>a</sup>	2,000
<b>Benefits:</b>	
Chemical savings (\$/yr) <sup>b</sup>	2,000
Waste treatment savings (\$/yr) <sup>c</sup>	3,000
Net Annual savings (\$/yr)	3,000
Return on investment (%)	12.5

<sup>a</sup>Does not include maintenance or operating labor.

<sup>b</sup>Copper at \$1/lb., drag-out at 1 lb Cu/h.

<sup>c</sup>Based on treatment and disposal at \$3/lb copper.

TABLE 47. EVALUATION OF HIGH-SURFACE AREA ELECTROLYTIC RECOVERY UNIT FOR CADMIUM CYANIDE PLATING

Item	Amount
Performance factors:	
Rinse tanks needed	2 (1 dead, 1 running)
Dead tank cadmium concentration (mg/l) <sup>a</sup>	34
% recovery:	
Cadmium	99+
Cyanide	0
Dead tank rinse rate (l/min)	140
Running rinse cadmium concentration (mg/l)	5
Running rinse rate (l/min)	4.4
Cost factors:	
Unit cost (\$)	61,000
Installation (\$)	6,000
Operation (\$/yr) <sup>b</sup>	2,000
Chemical savings (\$/yr):	
Cadmium	9,200
Cyanide	0
Treatment and solid waste savings (\$/yr) <sup>c</sup>	28,000
Annual operating savings (\$/yr) <sup>d</sup>	32,200
Return on investment (%)	53
General:	
Return on impurities	No
Effluent cadmium in mixed wastewater at 100 l/min <u>(mg/l)</u>	0.22

<sup>a</sup>Average concentration.

<sup>b</sup>Does not include maintenance or operating labor.

<sup>c</sup>Based on waste treatment and disposal cost of \$18/lb cadmium.

<sup>d</sup>Does not include costs for depreciation, labor, etc.

NOTE: Drag-out = 1 lb/h Cd at \$12,000 mg/l Cd and 4 lb/h CN at 4,800 mg/l CN. Operating 8 h/day, 250 days/yr.

ions from wastewater streams. The cation exchange membrane was field tested in 1979 for removal of nickel ions from nickel plating wastewater. Although the results appeared to be encouraging for further development, no additional work on that system has been reported. Anion exchange membranes were successfully used in laboratory studies to remove metal cyanide complex ions from solutions. Planned evaluation of a prototype unit has been delayed, however, because of difficulty in reproducing the anion membrane stable above pH 8.

The potential advantages of a Donnan dialysis system over other membrane technologies is that no pressure or electrical driving force is needed.

## 2. Process Description

The Donnan dialysis method is based on the Donnan membrane equation, which combines the requirement that each of two solutions separated by a membrane must remain electrically neutral, despite the driving force created between two solutions having different concentrations of the same ion. If two solutions with different concentrations of nickel ions are separated by a cation exchange membrane in its hydrogen ion form, nickel ions from the high concentration solution (I) will displace the hydrogen ions from the ion exchange sites. If, at the same time, the hydrogen ion concentration is maintained at a high level in the solution with low nickel ion concentration (II), nickel ions will be replaced by hydrogen ions on Side II of the membrane. The net effect is transport of nickel ions across the membrane from I to II, and transport of hydrogen ions from II to I. Anions cannot penetrate a nonporous cation exchange membrane, which therefore acts as a cation permeable valve. Because no anions are transported, to maintain electrical neutrality in both I and II, two hydrogen ions ( $2H^+$ ) must move from II to I when one nickel ion ( $Ni^{++}$ ) moves from I to II. If the hydrogen ion concentration is very low in I, and in II is initially much higher than the nickel ion concentration in I, the transport of hydrogen ion from II to I, and of nickel ion from I to II, will continue even after the nickel ion concentration in II exceeds that in I. Eventually an equilibrium concentration is reached when the ratios of cations on the two sides of the membrane satisfy the Donnan equilibrium conditions,

$$\frac{[H^+]_I}{[H^+]_{II}} = \frac{[Ni^{++}]_I}{[Ni^{++}]_{II}}^{\frac{1}{2}}$$

where ( $H^+$ ) and ( $Ni^{++}$ ) are hydrogen and nickel ion concentrations, respectively; I and II are the two solutions separated by the membrane; and the exponent 1/2 is obtained because the nickel ion has a valence of 2. The general form of the ratios is,

$$\frac{[\text{Me}^{+z}] \text{ I}^{\frac{1}{2}}}{[\text{Me}^{+z}] \text{ II}}$$

where  $\text{Me}^{+z}$  represents any metal ion with valence  $+z$ .

### 3. Process Description

In practice, a rinse water containing metal ions is passed thru a tubular cation exchange membrane, bathed on the outside with an acid solution (for example, 1 molar hydrochloric acid). Or a flat membrane may be clamped between two chambers. The solutions on both sides must be agitated sufficiently to keep the cation concentration gradient at a minimum in the immediate vicinity of the membrane. In the experiments with anion exchange membranes, sodium chloride solutions were used for stripping--the chloride ion providing the driving force to remove metal cyanide complex ions from the simulated rinse water stream. For cation and anion exchange membranes, concentration ratios (final concentration in stripping solution/initial concentration in simulated rinse water) were 17 to 20, and removals from the simulated rinse water were greater than 99 percent.

### 4. Operation and Maintenance Requirements and System Performance

No information is available because no pilot or prototype systems are under active evaluation.

### 5. Residuals Generated

Donnan dialysis systems would produce a concentrated solution of the ions removed. The treated stream from which metal ions were removed will have an increased concentration of the cations or anions used to generate the driving force (for example, hydrogen ions, or chloride ions in the cases discussed).

### 6. Cost Factors

No cost factors are available because of the absence of operating Donnan dialysis systems.

## H. ION TRANSFER MEMBRANES

### 1. Summary and State of Technology Development

Ion transfer membranes, as they are termed by their sole manufacturer (Innova Technology, Inc.), are the basis for two recovery systems dedicated to chromium plating operations. The first system developed was for recovery of chromate ions

from rinse solutions following the plating bath. It features an anode contained within a membrane module that selectively extracts chromate and other anions from the rinse solution. The membrane is not anion or cation selective, the anion selectivity is a result of the electrical driving force. The membranes are approximately 1/2-inch thick, and rigid; they are made of materials durable to the oxidizing effects of concentrated chromic acid. Ion passage is by capillary action and, by virtue of the membrane thickness, can operate against a significant concentration gradient (Reference 48).

The second unit developed was to extract cation impurities selectively from chromic acid solutions. The basic principle is the same as that for the first system, but a cathode is within the membrane compartment. The membrane for this application is constructed of different materials that are more suited to this application.

The units have been operating for chromate recovery since 1980; the chromic acid purification units have been operating since 1982. Both systems come with a guarantee against membrane failure for 2 years. Other applications based on use of the membranes are under development.

## 2. Process Description

The Innova chrome recovery unit (Chrome Napper<sup>R</sup>) is designed to take advantage of the significant amount of surface evaporation that normally occurs in chromium plating baths operating between 115°F and 125°F. By using countercurrent recycle of rinse water through multiple-rinse tanks and a chromium recovery unit on the final, clean rinse, the chromium plating process becomes a closed-loop operation. Such a system is shown in Figure 76. The closed-loop operation requires that the rinse solution be either manually or automatically recycled back to the plating bath.

The required capacity of the recovery unit is a function of the quantity of chromate available for recovery. The unit is designed based on individual membrane modules, and up to 12 modules can be housed in an individual recovery tank. The capacity of the module is influenced by solution conductivity to a limited degree. Module capacity varies from 25 gal/d to 50 gal/d of chromic acid, based on operation over 24 hours. The solution in the recovery cell can be concentrated up to 150 g/l of chromic acid.

The system shown in Figure 76 is a closed-loop system. Consequently, even though the recovery unit selectively recovers chromate and other anions, all cationic impurities will also be recycled. This problem can be avoided if the final rinse is dumped at the start of the shift (when chromate concentration is lowest) and the solution is replaced with fresh water.

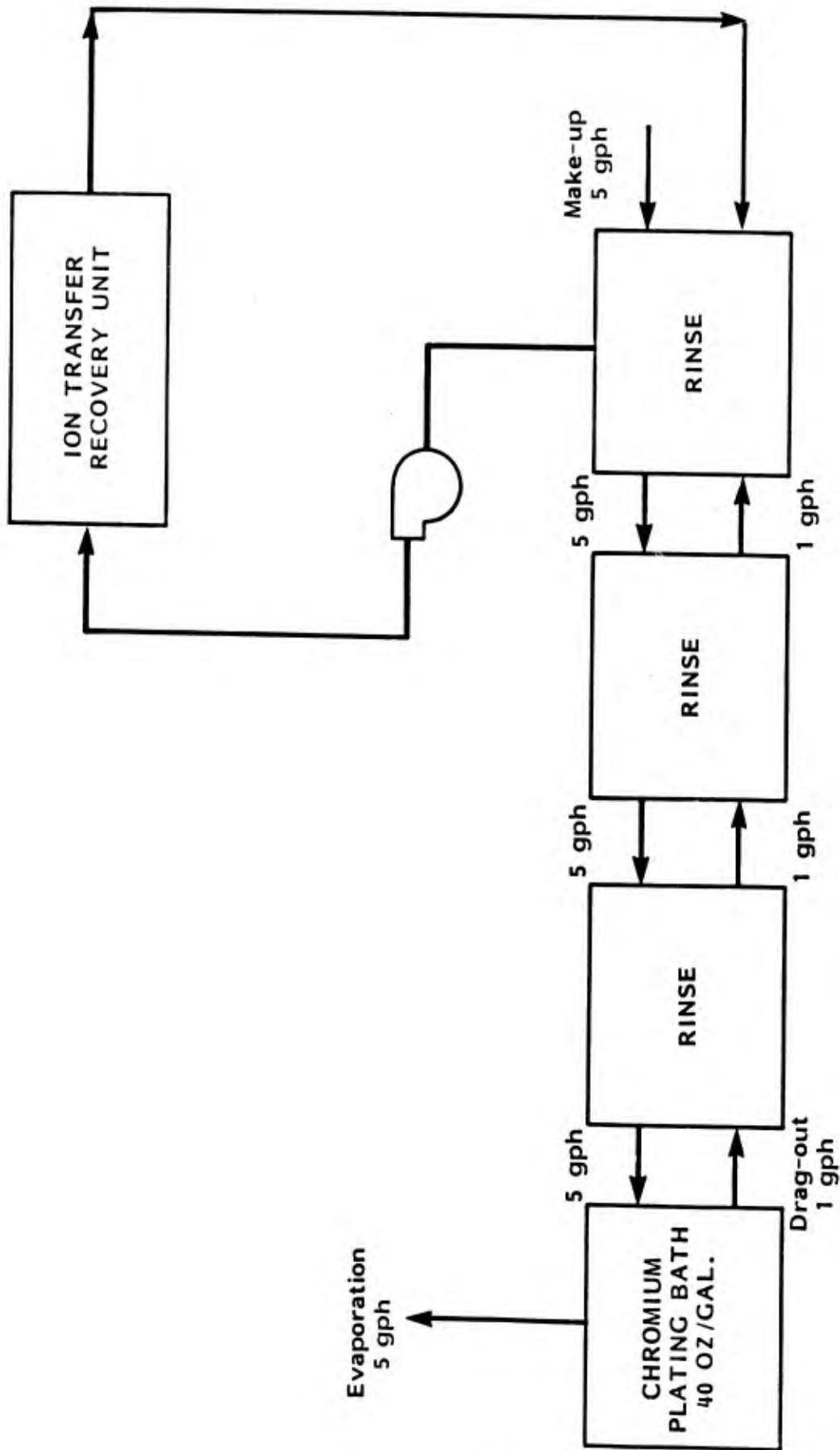

Figure 76 . Chromium Recovery by Ion Transfer Membrane Process

To deal with the problem of cation impurities, the manufacturer developed a similar unit but placed a cathode within the membrane compartment. The chromium plating solution circulates around the module, which will selectively extract cationic impurities. The solution--collected in the membrane compartment, which contains iron, trivalent chromium, and other cation impurities--is discharged to waste treatment for pH adjustment and metal removal. This unit is a significant advance over the conventional method of removing cation impurities by cationic ion exchange. Again, the capacity of the unit depends upon the number of membrane modules; normally, cation buildup in the bath does not occur at a high rate. The manufacturer has developed an inexpensive unit consisting of a single module that is placed directly in the bath. No data on capacity were available from the manufacturer.

### 3. Operation and Maintenance Requirements and System Performance

The main duty of the operator is to drain the solution periodically from the membrane compartments. A gauge on the unit indicates current flow, which is proportional to conductivity; when solution conductivity reaches a certain level, the unit should be drained. If the unit is a chromate recovery system, the solution is drained into a carboy and returned to the plating bath. If the unit is a bath purification system, the solution is sent to waste treatment.

Other operator duties include scheduled maintenance on pumps and blowers and routine checks on the unit's operation. The only utility needed is electricity.

The performance of the chrome recovery units operating in commercial applications has been reliable and has resulted in savings in both chromate drag-out and rinse water use. Little data exist on the performance of bath purification units.

### 4. Residuals Generated

The chrome recovery unit selectively recovers anions from the rinse solutions. The only residual is the recovered solution, which should be returned to the plating bath.

The bath purification unit selectively removes cations from the plating bath; the concentrate contains cationic metal impurities and should be discharged to the common waste treatment system to precipitate the metals.

### 5. Cost Factors

The basic recovery unit is equipped with the recovery tank, return pump, blower, control panel, rectifier, and all internal piping, valves, and auxiliary equipment, and its cost is \$16,000.

The modular membrane cells cost \$1,500 each; an individual tank can hold up to 12 modules. The only installation costs are for piping connection between the rinse tank and recovery unit and for a support structure for the unit's elevated installation.

A bath purification unit, with one membrane module suitable for submerging in the bath, costs \$750. The unit must be provided with a 25-volt DC power supply. No capacity data are available.

Table 48 gives an operating cost and chemical savings analysis for a unit. The basis for the savings is derived from the savings in chromium plus the cost avoided for waste treatment chemicals, solid waste disposal, and water and sewer charges. The analysis is merely an example; each individual case must be evaluated in terms of the factors defined in the analysis.

TABLE 48. COST-BENEFIT ANALYSIS OF ION TRANSFER  
CHROMIUM RECOVERY UNIT

Item	Amount (\$)
Investment costs:	
Chrome recovery unit, 12 modules <sup>a</sup>	34,000
Bath purification unit	1,000
Installation	2,000
Total installed cost	<u>37,000</u>
Annual operating cost:	
Labor (1/2 hour/shift at \$8/hour)	1,000
Maintenance	500
Electrical costs <sup>b</sup>	3,300
Membrane replacement <sup>c</sup>	2,400
Equipment depreciation <sup>d</sup>	1,600
Annual operating cost	<u>7,500</u>
Annual Savings	
Water and sewer fees <sup>e</sup>	300
Waste treatment chemicals	3,000
Sludge disposal (5 percent solid, \$0.50/gal)	5,400
Chromic acid recovery (5,000 lb/year) <sup>f</sup>	4,500
Total annual savings	<u>13,200</u>
Net savings	5,700
Basic return on investment (%)	15

- <sup>a</sup> Based on recovery of 38 g/d per module.  
<sup>b</sup> Operates 24 hour/day at \$0.07/kWh.  
<sup>c</sup> Membranes replaced every 3 years at \$600 per membrane.  
<sup>d</sup> 10 year life; no membrane depreciation.  
<sup>e</sup> Free rinse formerly 1 gal/min.  
<sup>f</sup> \$0.90/lb H<sub>2</sub>CrO<sub>4</sub>.

NOTE: Plating line operates 2,000 h/yr. Drag-out = 1 gal/hour at 40 oz H<sub>2</sub>CrO<sub>4</sub>. Surface evaporation = 5 gal/h. 3-tank rinse as in Figure 1. Water and Sewer fees at \$2.50/ 1,000 gallons. Chromic acid recovery 95% by rinse cycle, 5% by recovery unit.

## SECTION VI

### PLATING BATH SUBSTITUTION

#### A. OVERVIEW

Chemical manufacturers and suppliers have become concerned with the pollution control problems of their clients--the platers. As a result, research and development efforts by the chemical manufacturers have produced more environmentally sound plating solutions.

Cyanide plating baths have been a major target of the chemical manufacturers. The conventional cyanide bath has been preferred for many plating applications, such as zinc and cadmium. Because of stricter effluent limitations on cyanide, however, an alternative to high-concentration cyanide baths is being sought. The chemical manufacturers have experimented and, in some cases, have developed alkaline noncyanide or low-cyanide baths and acid baths including neutral chlorine solutions.

Platers should investigate and evaluate the various advantages and disadvantages of the new chemical solutions. As a rule, the acid bath substitutes do not offer the ease of control or the overall satisfactory operating conditions and deposit quality that are available from the cyanide bath. For zinc, cadmium, brass, and precious metals, the cyanide plating bath continues to be the most commonly used solution.

Most of the substitute solutions are limited in application. For instance, a trivalent chromium solution is now being marketed which can significantly decrease wastewater treatment needs. However, the bath is only applicable to decorative chromium plating and cannot be used for hard chromium processes operated by the military.

In this section the most current information is provided for substitute solutions most applicable to military plating. The discussion centers on zinc and nickel plating baths and noncyanide stripper solutions.

#### B. ZINC PLATING BATHS

##### 1. Summary and State of Technology Development

Conventional zinc cyanide baths have historically been preferred for general zinc plating owing to characteristics of good throwing power, ease of process control, a wide range of

satisfactory operating conditions, and experience with use of the bath. The high cyanide content of this bath, however, presents a waste disposal problem (Reference 49). Alternative baths, containing little or no cyanide, have been available since as early as the 1930s, but their use was limited by their poor throwing power and their inability to produce bright deposits (Reference 49). With increasing concern over the environmental effects of cyanide in the 1960s and 1970s, accompanied by the promulgation of strict effluent limitations, research efforts were directed toward improving the characteristics of alternative zinc plating baths. As a result, several useful alternative zinc baths have become available to electroplaters in the last decade. The alternative baths include low cyanide baths, an alkaline cyanide free bath, a proprietary neutral chloride bath, and a number of acid baths based on sulfate, chloride, and fluoborate (Reference 49).

Low cyanide baths minimize the amount of cyanide present in the bath and, hence, in the effluent. Cyanide is, however, still present in the effluent in sufficient quantities to require treatment. Conventional cyanide baths typically have a sodium cyanide concentration of 5-15 oz/gal, whereas low cyanide baths have sodium cyanide concentrations on the order of 1-4 oz/gal (Reference 50).

The proprietary neutral chloride bath contains no cyanide. This bath relies on ammonium ions for complexing the zinc. Sometimes proprietary chelating agents are used for stronger complexing of the zinc. This type of bath depends on additives to achieve the brightness necessary for satisfactory use in general plating applications. Although the neutral chloride bath contains no cyanide, the strong chelating agents themselves are a problem. These complexing agents make the removal of zinc from the effluent very difficult (Reference 49).

Acid zinc baths also contain no cyanide. Until the late 1960s, acid baths were confined to use with high production and purely protective applications, such as conduit and continuous steel wire and strip plating. In these particular applications, the high plating speed and operating costs were advantageous, and the poor throwing power and lack of fully bright deposits were not of serious concern. Now, with the development of new additives, acid zinc baths are capable of producing bright deposits and are competitive with the alkaline baths for general plating applications (Reference 49).

The most commonly used acid zinc bath is based on zinc sulfate. Other acid zinc baths are formulated with chloride and fluoborate. The acidity of the various baths may differ considerably. Perchlorate and sulfonate baths are also possible alternatives, but are seldom used (Reference 49).

Zinc sulfate or chloride can be purchased or zinc metal can be dissolved in sulfuric or hydrochloric acid to prepare the bath. Chlorides and sulfates, such as those of

sodium, ammonium, and aluminum, can be added to increase the conductivity of the bath. Free acid can also be used to increase the conductivity. Additives are needed for the production of smooth deposits; those commonly used for this purpose are dextrin, licorice, glucose, and gelatin. One distinct advantage of the acid bath is that it enables direct plating on cast iron and carbonitrided steel parts without a prior strike (Reference 49).

The selection of the proper bath for a given application ultimately depends on the specific characteristics desired of the bath. The characteristics of the various types of zinc plating baths are given in Table 49.

## 2. Process Description

Conventional zinc cyanide baths, by virtue of the bath composition, exhibit a slight degree of cleaning action. For this reason, prior cleaning steps, while recommended, are not as critical as for the alternative baths. Typical cleaning steps would include an alkaline cleaner followed by a rinse, an electrochemical cleaner followed by a rinse, and an acid dip followed by a rinse.

Other differences in the processes associated with each of the baths involve their composition and, hence, their operating conditions. These characteristics of the processes are given in Tables 50 and 51.

All types of zinc plating processes are susceptible to metallic impurities. To prevent the buildup of metallic impurities in the baths, a small excess of sulfide or polysulfide ions is generally maintained to cause lead, cadmium, or other metallic impurities to form insoluble sulfides and precipitate from the bath (Reference 49).

For conventional zinc cyanide baths the effective operating temperature range is rather wide. Temperatures at the low end of the range will usually provide greater stability of the addition agents and minimize the rate of decomposition of the cyanide. Higher temperatures, however, may increase plating speed and allow the use of more dilute baths, enhancing waste treatment economy.

Low cyanide and other alkaline baths have operating characteristics similar to conventional cyanide baths; however, the control of the operating characteristics is more critical, requiring more operator attention.

With acid zinc baths the pH should be controlled within the ranges specified for each type of bath. These baths are also sensitive to metallic impurities, but because of the lower pH, the sulfide precipitation used for conventional baths will not work for the acid baths. Acid baths are best purified

TABLE 49. CHARACTERISTICS OF CONVENTIONAL ZINC CYANIDE PLATING BATHS

Advantages	Disadvantages
Baths have a history of use in a wide variety of applications.	Some formulations can give higher throwing power than others, but the cathode efficiency is not very good.
Baths will always deposit a zinc film (except on some cast iron and carbonitrided iron parts) regardless of neglect in cleaning or bath composition.	The presence of cyanide requires treatment of the effluent.
Brightener systems yield a bright deposit over a wide range of current density.	
Cleaning before electroplating is not as critical as with other zinc plating systems.	
Control of the electroplating bath is easy.	
Coverage is good.	
Rate of deposit is rapid.	

SOURCE: Marce, Roger E., Zinc Plating, Metal Finishing Guidebook and Directory Issue '82, Metals and Plastics Publications, Inc., 1982, pp. 354-356.

TABLE 50. ALKALINE ZINC BATHS: TYPICAL ELECTROPLATING SOLUTIONS AND ASSOCIATED OPERATING CONDITIONS

Item	Conventional Cyanide	Low Cyanide	Alkaline No Cyanide	Pyrophosphate
Zinc (oz/gal)	3.5-6	1-3	1-2	3-4
Sodium cyanide (oz/gal)	5-14	1-4	--	--
Total cyanide (oz/gal)	12.3	--	--	--
Sodium hydroxide (oz/gal)	5-15	10-14	9-20	--
Sodium carbonate (oz/gal)	6	--	--	--
Potassium pyrophosphate (oz/gal)	--	--	--	40
Addition agent (oz/gal)	As needed	As needed	As needed	As needed
Temperature (°F)	75-95	Room	Room	110-125
Current density A/ft <sup>2</sup>	2-80	20-80	20-80	2-10

NOTE: Zinc anodes of 99.99% purity are recommended for all baths.

SOURCE: Marce, Roger E., Zinc Plating, Metal Finishing Guidebook and Directory Issue '82, Metals and Plastics Publications, 1982.

TABLE 51. NEUTRAL AND ACID ZINC BATHS: TYPICAL ELECTROPLATING SOLUTIONS AND ASSOCIATED OPERATING CONDITIONS

Item	Conventional Cyanide	Low Cyanide	Alkaline, No Cyanide	Pyrophosphate
Zinc (oz/gal)	3.5-7	9-14	1-5	18
Zinc chloride (oz/gal)	--	--	6	--
Zinc fluoborate (oz/gal)	--	30-50	--	--
Zinc sulfate (oz/gal)	--	--	--	50
Total chloride (oz/gal)	14-22	--	20-77	--
Ammonium fluoborate (oz/gal)	--	4-6	--	--
Ammonium chloride (oz/gal)	--	--	30	1-3
Boric acid (oz/gal)	3.5-4	--	--	--
Addition agent (oz/gal)	As needed	As needed	As needed	As needed
Temperature (°F)	75-100	Room	65-85	85-125
pH	7-7.7	35.-1	3-6	3-4
Current density A/ft <sup>2</sup>	2-80	20-60	10-150	10-60

NOTE: Zinc anodes of 99.99% purity are recommended for all baths.

SOURCE: Marce, Roger E., Zinc Plating, Metal Finishing Guidebook and Directory Issue '82, Metals and Plastics Publications, 1982.

by the addition of zinc dust. This dust poses a fire hazard and should be handled accordingly. If the zinc dust is not used, the impurities may tend to plate out by immersion on the zinc anodes (Reference 49).

### 3. Operation and Maintenance Requirements and System Performance

Routine operational requirements are generally greater with alternative zinc electroplating baths because of the greater degree of control necessary. Equipment maintenance should not vary greatly between the alternatives, provided that suitable materials of construction are used for the equipment.

The performance of the bath types differs greatly and cannot be generalized in terms of one bath being superior to another bath. The best bath to use will depend largely on the specific parts to be plated, and the significance of the cyanide waste treatment problem at the given facility.

If zinc cyanide plating baths are the only sources of cyanide at the facility, there would be a substantial financial incentive, in terms of eliminating the need for cyanide waste treatment equipment, to employ noncyanide plating baths. As is the case at many facilities, however, other cyanide sources are present, and either all must be eliminated, or the equipment will still be needed. The use of low-cyanide or noncyanide baths may, however, still reduce treatment costs.

### 4. Residuals Generated

The presence of cyanide itself does not result in the production of any sludge. The quantity of sludge produced will depend on the concentration of zinc in the effluent to be treated. Thus, the alternative baths with lower concentrations of zinc will reduce the quantity of sludge produced by treatment of the effluent.

The presence of chelating agents in alternative baths should be considered, however. These chelating agents make removal of the zinc more difficult and may result in an increase in sludge because of overaddition of treatment chemicals such as lime.

### 5. Cost Factors

The relative costs of the baths cannot be presented in general terms. Table 48 indicates those baths that initially cost more or less than conventional baths, but many other site specific factors would affect the economics of using a particular alternative bath. A list of factors to be considered in evaluation of the cost associated with using a particular alternative bath at a particular site follows:

- o Initial cost of bath

- Operating cost change associated with alternative bath (labor)
- Cost of support chemicals (additives)
- Cost of any equipment changes to allow the use of more corrosive chemicals
- Increase or decrease in production rate
- Savings resulting from decrease in treatment operating costs for reduced levels of cyanide
- Savings resulting from reduced investment cost if cyanide is totally eliminated
- Treatment operating cost change resulting from presence of chelating agents in effluent

## C. NICKEL PLATING BATHS

### 1. Summary and State of Technology Development

Nickel is perhaps the most versatile of all the metals used in electroplating. Because nickel plating accounts for a significant part of the total market for the metal, and because of all the plating metals nickel is the most sensitive to the effects of additives in the bath, much work has been done in the field of nickel plating (Reference 51).

Many varied types of nickel baths are available commercially. Selection of the proper bath depends for the most part on the intended application. This discussion focuses on two types of nickel baths likely to be applicable to Navy plating facilities: the Watts bath and the electroless or autocatalytic bath.

The Watts bath, named for its inventor, was first publicized in 1916. Over the years, performance of the bath has been improved by the use of additives, slightly higher concentrations, and improved anode compositions. Today the Watts nickel bath remains the most widely used bath in nickel plating operations (Reference 51).

Electroless nickel plating involves applying a nickel coating to a substrate without the use of an outside source of electric current. There are other methods, such as contact plating and immersion coating, for applying metallic coatings without outside electric currents, but these are deemed to be less applicable to the use of nickel.

Electroless plating was first discovered in 1946 during an investigation of chemical additives for nickel plating. One of the additives tested, sodium hypophosphite, resulted in a

cathode efficiency in excess of 100 percent, leading to the conclusion that chemical reduction was occurring. Investigations of chemical reductive plating have resulted in several practical techniques for the plating of nickel as well as other metals. A key to the process, however, is that the metal or alloy being deposited must catalyze the chemical reduction. Thus, not all metals can be deposited by this method. With metals that are suitable to the process, there is theoretically no limit to the thickness of deposits that can be produced (Reference 51).

Because of the expense of the chemical reducing agents required for electroless nickel plating, the process is not cost effective in applications where conventional electroplating techniques can be used. Electroless plating does, however, have a unique combination of characteristics that make it useful in many applications:

- The throwing power is essentially perfect; deposits are laid down on any surface to which the solution has free access, and no excessive buildup occurs on projections or edges.
- The deposits are frequently less porous than electro deposits, affording greater protection of the substrate.
- The process does not require power supplies, electric contacts, bus bars, or electrical measuring instruments.
- With appropriate pretreatment, deposits can be produced on nonconductors.
- Some deposits possess unique chemical, mechanical, or magnetic properties.

## 2. Process Description

The primary constituents of a Watts bath are nickel sulfate, nickel chloride, and boric acid. Table 52 gives a typical formulation for a Watts bath.

Nickel sulfate provides most of the nickel ions for the Watts bath. It is the least expensive nickel salt with a stable anion that is neither reduced at the cathode nor oxidized at the anode and that is nonvolatile. One change from the original Watts formulation has been to increase the nickel sulfate concentration. This change allows the use of a higher current density, resulting in better plate distribution and faster plating rates (Reference 52).

Nickel chloride serves as the source of chloride ions. These ions are required to prevent anode passivity. In addition, they increase the conductivity of the bath, and

improve the throwing power. Nickel chloride is preferred over other chloride compounds because the other compounds would contribute extraneous cations such as sodium, potassium, or ammonium to the bath. Unlike other metal deposits, nickel is sensitive to the presence of these cations and they would be detrimental to the nickel plating process (Reference 51).

TABLE 52. TYPICAL FORMATION OF WATTS NICKEL BATH

Item	Range	Nominal Value
Nickel sulfate (oz/gal) (NiSO <sub>4</sub> ·6H <sub>2</sub> O)	30-50	44
Nickel chloride (oz/gal) (NiCl <sub>2</sub> ·6H <sub>2</sub> O)	4-8	6
Boric acid (oz/gal) (H <sub>3</sub> BO <sub>3</sub> )	4-5.3	5
Temperature (°F)	110-150	140
pH	1.5-4.5	3-4
Current density (A/ft <sup>2</sup> )	25-100	50

SOURCE: Mazia, Joseph, ed., Metal Finishing: Guidebook and Directory Issue '82, Metals and Plastics Publications, Inc., NJ, 1982, p. 278.

The boric acid acts as a weak buffer, controlling the pH at the cathode. Its use produces whiter, smoother, and more ductile deposits. Boric acid is available commercially in pure form and is relatively inexpensive, stable, and nonvolatile (Reference 51).

The use of anionic antipitting or wetting agents is generally required with Watts baths. Pitting is caused by hydrogen bubbles that form and cling on the cathode during the plating process. Wetting agents prevent pitting by reducing the surface tension of the bath, which reduces the tendency of the bubbles to cling to the cathode. Sodium lauryl sulfate, in concentrations of 0.013 to 0.067 oz/gal, is commonly used as a wetting agent. Other proprietary wetting agents are commercially available for use with air-agitated baths.

Although hydrogen peroxide is also effective in controlling pitting, it requires careful concentration control

to ensure that it does not reach concentrations that are sufficiently high to degrade the properties of the nickel deposit (Reference 51).

In general, increasing the temperature within the range shown in Table 1 permits higher operating current densities with lower tank voltage, and results in a decrease in deposit hardness and an increase in ductility. Operation at the lower end of the pH range permits higher current densities, and improves the bath conductivity and throwing power. This approach, however, causes a decrease in cathode efficiency (Reference 51).

Agitation of the bath is recommended. This technique tends to increase the maximum current density limit for producing good deposits and prevents stratification of the bath in terms of concentration and temperature (Reference 53).

The structure and mechanical properties of nickel deposits from the Watts bath are very sensitive to the operating conditions; particularly the pH, temperature, and current density. An important aspect of the deposit is the internal stress. The following are general guidelines on how the operating conditions affect internal stress (Reference 53):

- Tensile stress increases as the chloride content of the bath increases.
- Temperature of deposition has variable effects, depending principally on the chloride content and current density.
- The effect of pH varies with bath composition; it is advisable to maintain pH below 5.0 in the Watts bath.
- Current density in the range of 100 to 500 A/m<sup>2</sup> has only a slight effect, usually in the direction of increasing tensile stress as current density increases.
- Superimposed alternating current can reduce stress.
- Agitation has little effect if the bath is pure; in brightplating baths decreased agitation will decrease stress.
- Many impurities and additives act to increase stress markedly. These include hydrogen peroxide; inorganics such as lead, zinc, iron, chromium, aluminum, and phosphate ion; organic impurities including sizing from anode bags, amines from insufficiently cured rubber linings, and excessive concentrations of certain brighteners.

The primary constituents of electroless nickel baths are a nickel salt, a reducing agent (most commonly sodium hypophosphite), and a compound (usually a salt of an organic acid) that serves both as a buffer and as a complexing agent for nickel.

There are essentially two types of electroless nickel baths in use today: acid baths and ammoniacal, or alkaline, baths. The acid baths, which are operated within a pH range of 4-7, have been of more commercial significance than the alkaline baths, which operate in a pH range of 8-10. Electroless nickel deposits from hypophosphate baths are not pure nickel. Typically, the deposits contain between 3 and 15 percent phosphorus, depending on the bath composition and operating conditions employed. The acid baths generally produce deposits with a phosphorus content of 7-12 percent by weight and are thus more popular for engineering applications owing to their high hardness values, superior wear characteristics, and superior corrosion resistance as compared with unalloyed electrodeposited nickel. In addition, the deposits from the acid baths are generally nonmagnetic (Reference 53).

The alkaline electroless baths generally produce deposits with less than 50 percent phosphorus, which are accordingly not as hard or resistant to corrosion as the acid deposits. The alkaline deposits are, however, more suitable to applications requiring good solderability or low electrical resistivity, or if magnetic properties are desired.

Table 53 gives typical formulations for acid and alkaline electroless nickel baths. In the acid bath the hydroxyacetate (glycolate) performs several functions; it acts as a buffer and a complexing agent for nickel, and it serves to increase the plating rate. In the alkaline bath, the complexing action required to prevent precipitation of nickel hydroxide is provided by the citrate ions and ammonium ions, which are derived from the sodium citrate and ammonium chloride, respectively.

### 3. Operation and Maintenance Requirements and System Performance

The electroless baths present corrosion problems similar to the conventional Watts bath. They require no electrical system, however, and thus eliminate maintenance requirements associated with that system.

Variation of operating conditions and the use of additives can markedly affect performance of the electroless nickel baths. Temperature, in particular, is a very critical factor. Thus, the electroless baths require somewhat stricter control of operating conditions than do conventional nickel electroplating baths. This requirement may increase the need for operator attention or necessitate some form of automatic controls, particularly to maintain the proper bath temperature.

TABLE 53. TYPICAL FORMULATIONS OF HYPOPHOSPHITE TYPE ELECTROLESS NICKEL PLATING BATHS

Item	Acid Bath	Alkaline Bath
Nickel chloride (oz/gal) ( $\text{NiCl}_2 \cdot 6\text{H}_2\text{O}$ )	3.9	3.9
Sodium hypophosphite (oz/gal) ( $\text{NaH}_2\text{PO}_2 \cdot \text{H}_2\text{O}$ )	1.3	1.3
Sodium hydroxyacetate (oz/gal) ( $\text{HOCH}_2\text{COONa}$ )	6.5	--
Sodium citrate (oz/gal) ( $\text{Na}_3\text{C}_6\text{H}_5\text{O}_7 \cdot 2\text{H}_2\text{O}$ )	--	10.9
Ammonium chloride (oz/gal) ( $\text{NH}_4\text{Cl}$ )	--	6.5
pH	4-6	8-10
Temperature ( $^{\circ}\text{F}$ )	194	194
Plating rate, nm/h	15	6

SOURCE: Lowenheim, Frederick A., Electroplating, McGraw-Hill Book Co., NY, 1978.

Although the operating requirements differ for each bath type, the determinant criteria for selecting the bath type are likely, in most cases, to be the characteristics of the metal deposit, as described earlier.

#### 4. Residuals Generated

A typical Watts nickel bath contains approximately 11 times as much nickel as an electroless nickel bath. For this reason, if drag-out amounts are assumed to be equal from either type of bath, the Watts bath is likely to result in the generation of 11 times as much sludge as the electroless bath during treatment. In addition, the Watts bath is operated at a slightly lower pH than the acid electroless bath, and at a much lower pH than the alkaline electroless bath. Thus, the Watts bath will require the largest amount of neutralizing reagent to precipitate the nickel as a hydroxide, which will result in a larger amount of sludge if lime is the neutralizing reagent. Likewise, considering the initial pH difference, the acid electroless bath may result in the generation of a slightly larger amount of sludge than the alkaline electroless bath.

## REFERENCES

1. Federal Register Volume 47, Number 169, August 31, 1982, pp. 38462-38478.
2. Federal Register Volume 44, Number 175, September 7, 1979, pp. 52590-52629.
3. 40 CFR261
4. Federal Register Volume 46, Number 151, August 6, 1981, pp. 40154-40163.
5. U.S. Environmental Protection Agency. Environmental Pollution Control Alternatives: Economics of Wastewater Treatment Alternatives for the Electroplating Industry. EPA 625/5-79-016. June 1979.
6. U.S. Environmental Protection Agency, EPA 625/8-82-008. Summary Report: Control and Treatment Technology for the Metal Finishing Industry--In-Plant Changes. EPA 625/8-82-008. January 1982.
7. Patterson, James W., Wastewater Treatment Technology, Ann Arbor Science Publishers Inc., 1978.
8. Economics of Wastewater Treatment Alternatives for the Electroplating Industry, USEPA Publication, EPA 625/5-79-016, June 1979.
9. Environmental Regulations and Technology - The Electroplating Industry - USEPA Publication, EPA 625/10-80-0001, August 1980.
10. Control and Treatment Technology for the Metal Finishing Industry - Sulfide Precipitation, USEPA Publication, EPA 625/8-80-003, April 1980.
11. An Investigation of Technologies for Hazardous Sludge Reduction of AFLC Industrial Waste Treatment Plants, Draft Report, April 28, 1983.
12. Controlling Pollution from the Manufacturing and Coating of Metal Products, USEPA Publication, EPA-625/3-77-009, May 1977.
13. Sludge Handling, Dewatering and Disposal Alternatives for the Metal Finishing Industry, USEPA Publication, EPA 625/5-82-018,

14. Control and Treatment Technology for the Metal Finishing Industry - Sulfide Precipitation, USEPA Publication, EPA 625/8-80-003, April 1980.
15. Control and Treatment Technology for the Metal Finishing Industry - Ion Exchange, USEPA Publication, EPA 625/8-80-007, June 1981.
16. An Investigation of Technologies for Hazardous Sludge Reduction of AFLC Industrial Waste Treatment Plants, Draft Report, April 28, 1983, Contract No. 086-35-81-C-0258.
17. Assessment of Emerging Technologies for Metal Finishing Pollution Control: Three Case Studies, NTIS PB-81-244485, October 1981.
18. Moussavi, M., and S. Shanmuga Sundaram, "Thermal Decomposition of Cyanide Waste," Plating and Surface Finishing, July 1982, pp. 67-71.
19. American Electroplaters' Society, Batch Hydrolysis System for the Destruction of Cyanides in Electroplating Effluents, EPA 600/2-51-070, 1982.
20. Tratnyek, Joseph P., Freeze Crystallization, Physical, Chemical, and Biological Treatment Techniques for Industrial Wastes, Arthur D. Little, Inc., Cambridge, MA, November 1976, pp. 25-2, 25-3.
21. Ibid., p. 25-3.
22. Idem.
23. Ibid., p. 25-4.
24. Sittig, Marshall, Electroplating and Related Metal Finishing Pollutant and Toxic Materials Control, Noyes Data Corporation, Park Ridge, NJ, 1978, p. 324.
25. Tratnyek, Freeze Crystallization, p. 25-6.
26. Sittig, Electroplating, p. 326.
27. Idem.
28. Idem.
29. Tratnyek, Freeze Crystallization, p. 25-13.
30. Ibid., p. 25-19.
31. Wing, R. E., and D. W. McFeeters, Insoluble Starch Xanthate Aids the Metal Finishing Industry in Meeting Heavy Metal Discharge Criteria, Northern Regional Research Center, Agricultural Research Center, U.S. Department of Agriculture.

32. Wing, R. E., "Processes for Heavy Metal Removal from Plating Wastewaters," First Annual Conference on Advanced Pollution Control for the Metal Finishing Industry, U.S. Environmental Protection Agency, Washington, D.C., EPA-600/8-78-010, May 1980.
33. Wing, R. E., et. al., Removal of Heavy Metals from Industrial Wastewaters Using Insoluble Starch Xanthate, U.S. Environmental Protection Agency, Washington, D.C., EPA-600/2-78-085, May 1978.
34. McFeeters, D. W., personal communication, April 1983.
35. Pollution Technology Systems, "Insoluble Starch Xanthate," Bulletin PTS 1-83, Pollution Technology Systems, Garland, Texas.
36. Pollution Technology Systems, Inc., "Technical Data Sheet," Garland, Texas.
37. Wing, R. E., "Corn Starch Compound Recovers Metals from Water," Industrial Wastes, January/February, 1975, p. 27.
38. Personal communication with R. W. Wing, Northern Regional Research Laboratory, Agriculture Research Service, U.S. Department of Agriculture, Peoria, Illinois, March 25, 1983.
39. Cherry, Kenneth F., Plating Waste Treatment, Ann Arbor Science, Ann Arbor, Michigan, 1982, p. 68.
40. Sittig, Marshall, Electroplating and Related Metal Finishing Pollutant and Toxic Materials Control, Noyes Data Corporation, Park Ridge, New Jersey, 1978, p. 251.
41. Cherry, Plating, p. 38.
42. Treatment of Electroplating Wastewater by Alkaline Ferrous Reduction of Chromium and Sulfide Precipitation, USAF Contract No. FO 8635-82-K-0089, May 1983.
43. Control and Treatment Technology for the Metal Finishing Industry - Evaporators, USEPA Publication, EPA 625/8-79-002, June 1979.
44. Coupled Transport Systems for Control of Heavy Metal Pollutants, USEPA Publication, EPA 600/2-79-181, August 1979.
45. Jain, C. D., "Electrodialysis and Its Applications," American Laboratory, October 1979, pp. 65-76.
46. Crampton, P. and R. Wilmoth, "Reverse Osmosis in the Metal Finishing Industry," Metal Finishing, March 1982, pp. 21-27.
47. "Electrolytic Wastewater Treatment," AES Illustrated Lectures, American Electroplaters' Society, 1980.

48. "Ion Transfer Recovers Chrome, Two Job Shops Reduce Chromium with Closed-Loop System," Industrial Finishing, March 1981.
49. Lowenheim, Frederick A., Electroplating, McGraw-Hill, Inc., 1978, pp. 175-180.
50. Marce, Roger E., "Zinc Plating," Metal Finishing Guidebook and Directory Issue '82, Metals and Plastics Publications, Inc., 1982, p. 354.
51. Lowenheim, Frederick A., Electroplating, McGraw-Hill, Inc., 1978, pp. 211-212, 390.
52. Major, Joseph, ed., Metal Finishing: Guidebook and Directory Issue '81, Metals and Plastics Publications, Inc., NJ, 1981, p. 278.
53. Major, Joseph, Metal Finishing: Guidebook and Directory Issue '82, Metals and Plastics Publications, Inc., NJ, 1982, p. 518.

## INDEX

<u>Subject</u>	<u>Page</u>
Centrifuge . . . . .	64, 67-68
Chelating compounds . . . . .	80, 81
Chromium reduction . . . . .	30, 31, 32-39, 83, 132-139, 143-147
Conventional method . . . . .	30, 31, 32-39
Ferrous sulfate . . . . .	143-147
Sacrificial iron anodes . . . . .	83, 136-139
Clarification . . . . .	55-62
Clean Water Act of 1977 . . . . .	1-5
Compression filter . . . . .	64, 68-71, 74
Conventional technologies . . . . .	6-8, 30-79
Chromium reduction . . . . .	30, 31, 32-39, 216
Cyanide oxidation . . . . .	30, 31
Flocculation/clarification . . . . .	30, 31
Precipitation . . . . .	31, 32
Sludge dewatering . . . . .	32
Coupled transport membranes . . . . .	153, 176-181
Cyanide oxidation . . . . .	30, 40-48, 80, 81, 148
Conventional method . . . . .	40-48, 80, 81
Ozone oxidation . . . . .	82, 83, 116-119
Thermal oxidation . . . . .	83, 120-122
Direct discharge . . . . .	1
Donnan Dialysis . . . . .	153, 210-214
Drag-out . . . . .	8, 10, 12, 17-26
Air knives . . . . .	26
Recovery rinsing . . . . .	17-26
Spray rinses . . . . .	26
Electrodialysis . . . . .	154, 181-186
Electrolytic . . . . .	154, 200-211
Evaporators . . . . .	154, 157-176
Atmospheric . . . . .	164
Chromium recovery . . . . .	170
Flash film . . . . .	159-162
Rising film . . . . .	157, 158-159
Submerged tube . . . . .	162
Ferrous sulfate reduction . . . . .	83, 143-148
Filter press . . . . .	64-66, 71, 74, 77
Freeze crystallization . . . . .	124-129
Flocculation . . . . .	55-62
Hazardous waste regulations . . . . .	2, 5
Electroplating wastes . . . . .	5
Hazardous criteria . . . . .	6
Resource Conservation and Recovery Act (RCRA) . . . . .	2, 5
Insoluble starch xanthate . . . . .	130-136

INDEX (continued)

<u>Subject</u>	<u>Page</u>
Indirect discharge . . . . .	.1
In-plant changes . . . . .	8, 10-29
Integrated treatment . . . . .	.83, 148-151
Ion exchange . . . . .	.82, 96-112, 153
Chelating resins . . . . .	99, 105, 109
End-of-pipe . . . . .	.103, 105, 109
Metals recovery . . . . .	.96, 109-112
Polishing . . . . .	.96, 103, 105, 109
Strong base resins . . . . .	98
Strong acid resins . . . . .	98
Wastewater purification . . . . .	96, 99-103
Ion transfer membranes . . . . .	153, 214-219
Materials recovery . . . . .	8, 96, 152-219
Metals recovery . . . . .	8, 96, 152-219
Cadmium . . . . .	.158, 181, 205
Chromium . . . . .	.26, 96, 153, 176, 178
Copper . . . . .	.153, 176, 207
Gold . . . . .	.181
Nickel . . . . .	96, 153, 176, 178, 214
Silver . . . . .	153, 181
Tin . . . . .	204
Zinc . . . . .	153, 181
Oxidation reduction potential . . . . .	33, 38, 41, 42, 45
Ozone oxidation . . . . .	.82, 83, 116-119
pH control . . . . .	.30, 32, 33-36, 38, 40, 42, 51, 85, 87
Plating bath purification . . . . .	27-29, 96, 154
Plating bath substitution . . . . .	8
Pollution sources . . . . .	10-12, 27
Pollution/water use reduction . . . . .	8, 10-29
Polyelectrolytes . . . . .	.55-62, 84
Polishing filter . . . . .	62, 87
Precipitation . . . . .	30-33, 48-62
Conventional method . . . . .	30-33, 48-62
Sodium borohydride . . . . .	.82, 112-115
Sulfide . . . . .	.82, 84-95
Pretreatment standards . . . . .	1-4
Reverse Osmosis . . . . .	153, 185-201
Types . . . . .	187, 188
Membrane materials . . . . .	187-189
Rinsing . . . . .	10-26, 152
Conductivity cells . . . . .	13, 16
Countercurrent . . . . .	.13, 16, 23, 152
Flow regulators . . . . .	13, 17
Hard chromium . . . . .	26
Parallel . . . . .	16, 17
Spray . . . . .	26
Recovery . . . . .	17-26, 154, 155

INDEX (continued)

<u>Subject</u>	<u>Page</u>
Sacrificial iron anodes . . . . .	.83, 136-140
Sludge . . . . .	5, 30, 32, 51, 62-79, 84, 85
Dewatering . . . . .	32, 62
Disposal . . . . .	62, 85
Generation . . . . .	.48, 49, 51, 52, 80, 79, 114
Regulations . . . . .	.5, 63, 80, 79
Thickening . . . . .	32
Sodium borohydride treatment . . . . .	82, 112-115
Substitute treatment . . . . .	.6, 8, 9, 80-151
Sulfide precipitation . . . . .	.82, 84-95
Thermal oxidation . . . . .	.120-122
Treatment chemicals	
Chlorine (Cl <sub>2</sub> ) . . . . .	18, 40, 81
Ferrous sulfate . . . . .	.143-148
Lime (Ca(OH) <sub>2</sub> ) . . . . .	32, 48
Ozone (O <sub>3</sub> ) . . . . .	.112-119
Sodium bisulfite (NaHSO <sub>3</sub> ) . . . . .	32, 37, 39
Sodium borohydride (NaBH <sub>4</sub> ) . . . . .	.82, 112-115
Sodium hydroxide (NaOH) . . . . .	40, 48
Sodium hypochlorite (NaOCl) . . . . .	18, 40, 81
Sodium metabisulfite . . . . .	32, 37, 39
Sodium sulfide (Na <sub>2</sub> S) . . . . .	84
Sodium hydrosulfide (NaHS) . . . . .	84
Sulfur dioxide (SO <sub>2</sub> ) . . . . .	18, 32, 33, 37, 39
Sulfuric acid (H <sub>2</sub> SO <sub>4</sub> ) . . . . .	18, 32, 33, 39
Ultrafiltration . . . . .	.83, 139-143
Waste segregation . . . . .	.9, 38, 39, 49
Water pollution regulations . . . . .	.1-4
Best available treatment (BAT) . . . . .	2, 4
Best practical treatment (BPT) . . . . .	2, 4
Pretreatment standards . . . . .	1-4
Water reduction . . . . .	12-17
Water reuse . . . . .	12, 17
Zero discharge . . . . .	26, 154

## DISTRIBUTION LIST

ARMY Fal Engr, Letterkenny Army Depot, Chambersburg, PA  
AF AERO DEF COM HQS/DEE (T. Hein), Colorado Springs CO  
AF HQ LEEH (J Stanton) Washington, DC  
AFB (AFIT/LDE), Wright Patterson OH; AF Tech Office (Mgt & Ops), Tyndall, FL; AFESC/TST, Tyndall FL;  
CESCH, Wright-Patterson; HQ MAC/DEEE, Scott, Il; SAMSO/MNND, Norton AFB CA; Scol of Engrng  
(AFIT/DET); Stinfo Library, Offutt NE  
NATL ACADEMY OF ENG. Alexandria, VA  
ARMY ARRADCOM, Dover, NJ; BMDSC-RE (H. McClellan) Huntsville AL; DAEN-CWE-M, Washington  
DC; DAEN-MPE-D Washington DC; DAEN-MPU, Washington DC; ERADCOM Tech Supp Dir.  
(DELSD-L) Ft. Monmouth, NJ; Engr District (Memphis) Library, Memphis TN; HQDA (DAEN-FEE-A);  
Tech. Ref. Div., Fort Huachuca, AZ  
ARMY - CERL Library, Champaign IL  
ARMY AMMUNITION PLANT Sarhw - FEM Hawthorne, NY  
ARMY CORPS OF ENGINEERS MRD-Eng. Div., Omaha NE; Seattle Dist. Library, Seattle WA  
ARMY ENG DIV HNDED-CS, Huntsville AL; HNDED-FD, Huntsville, AL  
ARMY ENG WATERWAYS EXP STA Library, Vicksburg MS  
ARMY ENVIRON. HYGIENE AGCY HSE-EW Water Qual Eng Div Aberdeen Prov Grnd MD  
ARMY MATERIALS & MECHANICS RESEARCH CENTER Dr. Lenoe, Watertown MA  
ARMY-DEPOT SYS COMMAND DRSDS-AI Chambersburg, PA  
ARMY-MERADCOM CFLO Engr Fort Belvoir VA; DRDME-WC Ft Belvoir VA  
ADMINSUPU PWO, BAHRIAN  
CINCPAC Fac Engrng Div (J44) Makalapa, HI  
CINCUSNAVEUR Fleet Civil Engr, London, England  
CNAVRES Code 13 (Dir. Facilities) New Orleans, LA  
CNM NMAT - 044, Washington DC  
CNO Code NOP-964, Washington DC; OP-411F, Wash DC; OP987J, Washington, DC  
COMFAIRMED SCE, Code N55, Naples IT  
COMFAIRWESTPAC Security Offr, Misawa Japan  
COMFLEACT, OKINAWA SCE, Yokosuka Japan  
DOD Staff Spec. Chem. Tech. Washington DC  
DTIC Defense Technical Info Ctr/Alexandria, VA  
DTNSRDC Anna Lab (Code 4120) Annapolis MD; Code 284 (A. Rufolo), Annapolis MD  
DTNSRDC Code 4111 (R. Gierich), Bethesda MD; Code 42, Bethesda MD  
DTNSRDC Code 522 (Library), Annapolis MD  
ENVIRONMENTAL PROTECTION AGENCY Reg. III Library, Philadelphia PA; Reg. VIII, 8M-ASL,  
Denver CO  
GIDEP OIC, Corona, CA  
GSA Assist Comm Des & Cnst (FAIA) D R Dibner Washington, DC  
LIBRARY OF CONGRESS Washington, DC (Sciences & Tech Div)  
MARINE CORPS BASE Code 406, Camp Lejeune, NC; M & R Division, Camp Lejeune NC; Maint Off Camp  
Pendleton, CA; PWD - Maint. Control Div. Camp Butler, Kawasaki, Japan; PWO Camp Lejeune NC;  
PWO, Camp Pendleton CA  
MARINE CORPS HQS Code LFF-2, Washington DC  
MCAS Facil. Engr. Div. Cherry Point NC; CO, Kaneohe Bay HI; Code S4, Quantico VA; Facs Maint Dept -  
Operations Div, Cherry Point; PWD - Utilities Div, Iwakuni, Japan; PWO, Iwakuni, Japan; PWO, Yuma  
AZ  
MCDEC M&L Div Quantico VA  
MCLB B520, Barstow CA  
NAF PWO, Atsugi Japan  
NARF Code 612, Jax, FL; Code 640, Pensacola FL; SCE Norfolk, VA; Security Officer, (Code 011), Norfolk,  
VA  
NAS Code 114, Alameda CA; Code 183 (Fac. Plan BR MGR); Code 18700, Brunswick ME; Code 70, Atlanta,  
Marietta GA; Code 8E, Patuxent Riv., MD; Dir of Engrng, PWD, Corpus Christi, TX; PW (J. Maguire),  
Corpus Christi TX; PWD - Engr Div Dir, Millington, TN; PWD - Engr Div, Gtmo, Cuba; PWD - Engr Div,  
Oak Harbor, WA; PWD - Maint. Control Dir, Millington, TN; PWD Maint. Div., New Orleans, Belle  
Chasse LA; PWD, Code 1821H (Pfankuch) Miramar, SD CA; PWD, Willow Grove PA; PWO (Code 18.2),  
Bermuda; PWO Belle Chasse, LA; PWO Key West FL; PWO Lakehurst, NJ; PWO Patuxent River MD;  
PWO Whiting Fld, Milton FL; PWO, Cecil Field FL; PWO, Dallas TX; PWO, Glenview IL; PWO, Kingsville  
TX; PWO, Millington TN; PWO, Miramar, San Diego CA; PWO, Oceana, Virginia Bch VA; PWO, So.  
Weymouth MA; PWO., Moffett Field CA; SCE Norfolk, VA  
NATL RESEARCH COUNCIL Naval Studies Board, Washington DC  
NAVAIRDEVCCEN PWD, Engr Div Mgr, Warminster, PA

NAVAIRPROPTSTCEN CO, Trenton, NJ  
 NAVAVIONICFAC PW Div Indianapolis, IN  
 NAVAVNWPNSFAC Wpns Offr, St. Mawgan, England  
 NAVCOASTSYSCEN Code 423 Panama City, FL; Library Panama City, FL; PWO Panama City, FL  
 NAVCOMMAREAMSTRSTA SCE Unit 1 Naples Italy; SCE, Guam  
 NAVEDTRAPRODEVCCEN Technical Library, Pensacola, FL  
 NAVEDUTRACEN Engr Dept (Code 42) Newport, RI  
 NAVENVIRHLTHCEN CO, NAVSTA Norfolk, VA  
 NAVEODTECHCEN Code 605, Indian Head MD  
 NAVFAC M & O Officer Bermuda; PWO, Point Sur, Big Sur CA  
 NAVFACENGCOM Alexandria, VA; Code 0454B Alexandria, VA; Code 04A1 Alexandria, VA; Code 051A  
 Alexandria, VA; Code 09M54, Tech Lib, Alexandria, VA; Code 1113, Alexandria, VA; code 08T  
 Alexandria, VA  
 NAVFACENGCOM - CHES DIV. Code 405 Wash, DC; Code 406 Washington DC; Library, Washington, D.C.  
 NAVFACENGCOM - LANT DIV. Code 403, Norfolk, VA; Code 405 Civil Engr BR Norfolk VA; Eur. BR  
 Deputy Dir, Naples Italy; Library, Norfolk, VA; RDT&ELO 102A, Norfolk, VA  
 NAVFACENGCOM - NORTH DIV. (Boretsky) Philadelphia, PA; CO; Code 04AL, Philadelphia PA; Code  
 09P Philadelphia PA; Code 111 Philadelphia, PA; Code 114 (A. Rhoads)  
 NAVFACENGCOM - PAC DIV. CODE 09P PEARL HARBOR HI; Code 402, RDT&E, Pearl Harbor HI;  
 Library, Pearl Harbor, HI  
 NAVFACENGCOM - SOUTH DIV. Code 406 Charleston, SC; Code 90, RDT&ELO, Charleston SC; Library,  
 Charleston, SC  
 NAVFACENGCOM - WEST DIV. Code 04B San Bruno, CA; Code 101.6 San Bruno, CA; Code 114C, San  
 Diego CA; Code 405 San Bruno, CA; Library, San Bruno, CA; 09P/20 San Bruno, CA; RDT&ELO San  
 Bruno, CA; Security Offr, San Diego CA  
 NAVFACENGCOM CONTRACTS AROICC, Quantico, VA  
 NAVFORCARIB Commander (N42), Puerto Rico  
 NAVMAG SCE, Subic Bay, R.P.  
 NAVOCEANO Library Bay St. Louis, MS  
 NAVOCEANSYSCEN Code 4473B (Tech Lib) San Diego, CA  
 NAVORDSTA PWO, Louisville KY  
 NAVPHIBASE Code S3T, Norfolk VA; PWO Norfolk, VA  
 NAVREGMEDCEN PWO, Okinawa, Japan  
 NAVREGMEDCEN SCE; SCE, Camp Pendleton CA; SCE, Oakland CA  
 NAVSCOLCECOFF C35 Port Hueneme, CA; CO, Code C44A Port Hueneme, CA  
 NAVSEASYSKOM Code SEA OOC Washington, DC; SEA 04E (L Kess) Washington, DC  
 NAVSECGRUACT PWO Winter Harbor ME; PWO, Edzell Scotland; PWO, Puerto Rico  
 NAVSHIPPREPFAC SCE, Yokosuka Japan  
 NAVSHIPYD Bremerton, WA (Carr Inlet Acoustic Range); Code 202.5 (Library) Puget Sound, Bremerton  
 WA; Code 380, Portsmouth, VA; Code 400, Puget Sound; Code 410, Mare Is., Vallejo CA; Code 440  
 Portsmouth NH; Code 440, Norfolk; Code 440, Puget Sound, Bremerton WA; Code 457 (Maint. Supr.)  
 Mare Island, Vallejo CA; L.D. Vivian; Library, Portsmouth NH; PW Dept, Long Beach, CA; PWD (Code  
 420) Dir Portsmouth, VA; PWD (Code 450-HD) Portsmouth, VA; PWD - Utilities Supt, Code 903, Long  
 Beach, CA; PWO, Bremerton, WA; PWO, Mare Is.; PWO, Puget Sound; SCE, Pearl Harbor HI; Tech  
 Library, Vallejo, CA  
 NAVSTA CO Roosevelt Roads P.R. Puerto Rico; Dir Engr Div, PWD, Mayport FL; Dir Mech Engr 37WC93  
 Norfolk, VA; Engr. Dir., Rota Spain; Long Beach, CA; PWD (LTJG.P.M. Motolenich), Puerto Rico; PWD  
 - Engr Dept, Adak, AK; PWD - Engr Div, Midway Is.; PWO, Keflavik Iceland; PWO, Mayport FL; SCE,  
 Guam; SCE, Subic Bay, R.P.; Utilities Engr Off. Rota Spain  
 NAVSUPPACT PWO Naples Italy  
 NAVSUPPFAC PWD - Maint. Control Div, Thurmont, MD  
 NAVSUPPO Security Offr, Sardinia  
 NAVSURFWPNCEN PWO, White Oak, Silver Spring, MD  
 NAVTECHTRACEN SCE, Pensacola FL  
 NAVWARCOL Dir. of Facil., Newport RI  
 NAVWPNCEN Code 2636 China Lake; PWO (Code 266) China Lake, CA  
 NAVWPNSTA Code 092, Colts Neck NJ; Code 092, Concord CA; Engrng Div, PWD Yorktown, VA; Maint.  
 Control Dir., Yorktown VA  
 NAVWPNSTA PW Office Yorktown, VA  
 NAVWPNSTA PWD - Maint Control Div, Charleston, SC; PWD - Maint. Control Div., Concord, CA; PWD -  
 Supr Gen Engr, Seal Beach, CA; PWO Colts Neck, NJ; PWO, Charleston, SC; PWO, Seal Beach CA  
 NAVWPNSUPPCEN Code 09 Crane IN  
 NCBC Code 10 Davisville, RI; Code 400, Gulfport MS; Code 430 (PW Engrng) Gulfport, MS; Code 470.2,  
 Gulfport, MS; Library, Davisville, RI; NEESA Code 252 (P Winters) Port Hueneme, CA; PWO (Code 80)  
 Port Hueneme, CA; PWO, Gulfport, MS; Technical Library, Gulfport, MS  
 NCR 20, Code R70

NOAA Library Rockville, MD  
NORDA Code 410 Bay St. Louis, MS  
NSC Code 54.1 Norfolk, VA; Code 700 Norfolk, VA; SCE Norfolk, VA; SCE, Charleston, SC  
NSD SCE, Subic Bay, R.P.  
NUSC DET Code 5202 (S. Schady) New London, CT; Code EA123 (R.S. Munn), New London CT; Code SB 331 (Brown), Newport RI  
ONR Code 481, Bay St. Louis, MS; Code 700F Arlington VA  
PWC CO, (Code 10), Oakland, CA; Code 10, Great Lakes, IL; Code 105 Oakland, CA; Code 110, Oakland, CA; Code 120, Oakland CA; Code 128, Guam; Code 154 (Library), Great Lakes, IL; Code 200, Guam; Code 30V, Norfolk, VA; Code 400, Great Lakes, IL; Code 400, Pearl Harbor, HI; Code 400, San Diego, CA; Code 420, Oakland, CA; Code 424, Norfolk, VA; Code 500, Great Lakes, IL; Code 500, Oakland, CA; Code 600, Great Lakes, IL; Code 610, San Diego Ca; Code 700, Great Lakes, IL; Library, Code 120C, San Diego, CA; Library, Guam; Library, Norfolk, VA; Library, Pearl Harbor, HI; Library, Pensacola, FL; Library, Subic Bay, R.P.; Library, Yokosuka JA; Production Officer, Norfolk, VA; Util Dept (R Pascua) Pearl Harbor, HI; Utilities Officer, Guam  
SPCC PWO (Code 120) Mechanicsburg PA  
U.S. MERCHANT MARINE ACADEMY Kings Point, NY (Reprint Custodian)  
US NATIONAL MARINE FISHERIES SERVICE Highlands NY (Sandy Hook Lab-Library)  
USCG G-EOE-4 (T Dowd), Washington, DC; Library Hqs Washington, DC  
USCG R&D CENTER CO Groton, CT; D. Motherway, Groton CT; Library New London, CT  
USDA Forest Service, Bowers, Atlanta, GA  
USNA ENGRNG Div, PWD, Annapolis MD; Energy-Environ Study Grp, Annapolis, MD; Environ. Prot. R&D Prog. (J. Williams), Annapolis MD; PWO Annapolis MD; USNA/SYS ENG DEPT ANNAPOLIS MD  
BERKELEY PW Engr Div, Harrison, Berkeley, CA  
CALIFORNIA INSTITUTE OF TECHNOLOGY Pasadena CA (Keck Ref. Rm)  
CORNELL UNIVERSITY Ithaca NY (Serials Dept, Engr Lib.)  
KEENE STATE COLLEGE Keene NH (Cunningham)  
LEHIGH UNIVERSITY Bethlehem PA (Linderman Lib. No.30, Flecksteiner)  
MIT Cambridge MA; Cambridge MA (Rm 10-500, Tech. Reports, Engr. Lib.)  
NY CITY COMMUNITY COLLEGE BROOKLYN, NY (LIBRARY)  
PURDUE UNIVERSITY Lafayette, IN (CE Engr. Lib)  
STATE UNIV. OF NEW YORK Buffalo, NY; Fort Schuyler, NY (Longobardi)  
UNIVERSITY OF CALIFORNIA Berkeley CA (E. Pearson); LIVERMORE, CA (LAWRENCE LIVERMORE LAB, TOKARZ)  
UNIVERSITY OF HAWAII HONOLULU, HI (SCIENCE AND TECH. DIV.)  
UNIVERSITY OF ILLINOIS Metz Ref Rm, Urbana IL; URBANA, IL (LIBRARY)  
UNIVERSITY OF WASHINGTON (FH-10, D. Carlson) Seattle, WA; SEATTLE, WA (OCEAN ENG RSCH LAB, GRAY)  
UNIVERSITY OF WISCONSIN Milwaukee WI (Ctr of Great Lakes Studies)  
VENTURA COUNTY PWA (Brownie) Ventura, CA  
VIRGINIA INST. OF MARINE SCI. Gloucester Point VA (Library)  
BRITISH EMBASSY M A Wilkins (Sci & Tech Dept) Washington, DC  
GRUMMAN AEROSPACE CORP. Bethpage NY (Tech. Info. Ctr)  
NEWPORT NEWS SHIPBLDG & DRYDOCK CO. Newport News VA (Tech. Lib.)  
TEXTRON INC BUFFALO, NY (RESEARCH CENTER LIB.)  
UNITED KINGDOM LNO, USA Meradcom, Fort Belvoir, VA  
UNITED TECHNOLOGIES Windsor Locks CT (Hamilton Std Div., Library)  
WESTINGHOUSE ELECTRIC CORP. Library, Pittsburgh PA  
WM CLAPP LABS - BATTELLE DUXBURY, MA (LIBRARY)