

AD-A140 812

MULTITECHNIQUE STUDIES ON FRETTING FATIGUE: INFLUENCE OF SURFACE TREATMENT(U) BUNDESANSTALT FUER MATERIALPRUEFUNG BERLIN (GERMANY F R) H SANDER JAN 84 1/1

UNCLASSIFIED

DAJA45-83-C-0019

F/G 11/6

NL



END
DATE
FILMED
1983 JAN 11
DTIC

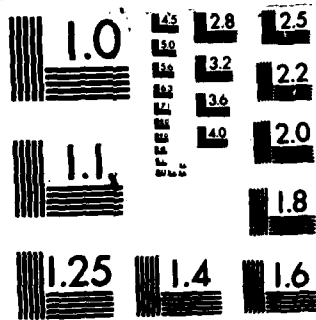

MICROCOPY RESOLUTION TEST CHART
NATIONAL BUREAU OF STANDARDS-1963-A

12

AD R+D 4058-AN

Multitechnique Studies on Fretting Fatigue:
Influence of Surface Treatment

AD-A140 812

Annual Technical Report

by

Harro Sander

January 1984

United States Army

EUROPEAN RESEARCH OFFICE OF THE U.S. ARMY

London England

Contract Number DAJA 45-83-C-0019

DTIC FILE COPY

DTIC
ELECTRONIC
MAY 04 1984
S E D

Bundesanstalt für Materialprüfung Berlin (BAM)

Approved for Public Release; distribution unlimited

84 05 03 005

unclassified

SECURITY CLASSIFICATION OF THIS PAGE (When Data Entered)

REPORT DOCUMENTATION PAGE		READ INSTRUCTIONS BEFORE COMPLETING FORM
1. REPORT NUMBER	2. GOVT ACCESSION NO. AD-A140 812	3. RECIPIENT'S CATALOG NUMBER
4. TITLE (and Subtitle) MULTITECHNIQUE STUDIES ON FRETTING FATIGUE; INFLUENCE OF SURFACE TREATMENT		5. TYPE OF REPORT & PERIOD COVERED Annual. Jan.-Dez. 1983
		6. PERFORMING ORG. REPORT NUMBER
7. AUTHOR(s) Harro Sander		8. CONTRACT OR GRANT NUMBER(s) DAJA 45-83-C-0019
9. PERFORMING ORGANIZATION NAME AND ADDRESS Bundesanstalt für Materialprüfung (BAM) Unter den Eichen 87 D - 1000 Berlin 45		10. PROGRAM ELEMENT, PROJECT, TASK AREA & WORK UNIT NUMBERS
11. CONTROLLING OFFICE NAME AND ADDRESS		12. REPORT DATE January 1984
		13. NUMBER OF PAGES 10
14. MONITORING AGENCY NAME & ADDRESS (if different from Controlling Office)		15. SECURITY CLASS. (of this report) unclassified
		15a. DECLASSIFICATION/DOWNGRADING SCHEDULE
16. DISTRIBUTION STATEMENT (of this Report)		
17. DISTRIBUTION STATEMENT (of the abstract entered in Block 20, if different from Report)		
18. SUPPLEMENTARY NOTES		
19. KEY WORDS (Continue on reverse side if necessary and identify by block number) fretting fatigue, surface treatment, surface roughness, steel, fatigue cracks, grinding, polishing, contact resistance, magnetic induction.		
20. ABSTRACT (Continue on reverse side if necessary and identify by block number) The problem of fretting fatigue is becoming more acute as in- creasing demands are placed on materials. As the conditions of contacting surfaces are of great influence for the fretting fatigue process, a project has been initiated to investigate the influence of mechanical surface treatments on the fretting fa- tigue behaviour of steel specimens. One of the initial steps taken has been the development of an experimental apparatus and t.s.p.		

DD FORM 1 JAN 73 1473 EDITION OF 1 NOV 68 IS OBSOLETE

unclassified

SECURITY CLASSIFICATION OF THIS PAGE (When Data Entered)

unclassified

SECURITY CLASSIFICATION OF THIS PAGE(When Data Entered)

cont. of 20.

a test technique that allows the fretting and fatigue process to occur simultaneously. The experimental program and the apparatus needed for investigating the effect of mechanical surface treatments on fretting fatigue is described.

Accession For	
NTIS GRA&I	<input checked="" type="checkbox"/>
DTIC TAB	<input type="checkbox"/>
Unannounced	<input type="checkbox"/>
Justification	
By _____	
Distribution/	
Availability Codes	
Dist	Avail and/or Special
A1	



unclassified

SECURITY CLASSIFICATION OF THIS PAGE(When Data Entered)

Abstract

The problem of fretting fatigue is becoming more acute as increasing demands are placed on materials. As the conditions of contacting surfaces are of great influence on the fretting fatigue process, a project has been initiated to investigate the influence of mechanical surface treatments on the fretting fatigue behaviour of steel specimens. One of the initial steps taken has been the development of an experimental apparatus and a test technique that allows the fretting and fatigue process to occur simultaneously. The experimental program and the apparatus needed for investigating the effect of mechanical surface treatments on fretting fatigue is described.

Keywords: fretting fatigue, surface treatment, surface roughness, steel, fatigue cracks, grinding, polishing, contact resistance, magnetic induction.

Table of Contents

	<u>page</u>
1. Introduction	1
2. Experimental objectives	2
3. Experimental approach	3
4. Specimens	4
5. Test apparatus	5
6. Control of experiments and data acquisition	8
7. Conclusion	9

List of Illustrations

Fig. 1 - Schematic diagram of fretting fatigue test setup	3
Fig. 2 - Test specimen	4
Fig. 3 - Fretting pad	5
Fig. 4 - Schematic diagram of test apparatus	7

1. Introduction

Fretting occurs where there is repeated movement between metallic surfaces in contact. Its effect on fatigue is to speed up the initiation of fatigue cracks and it can be extremely damaging. This phenomenon is called fretting fatigue. Failures due to fretting fatigue have become increasingly numerous. Fretting fatigue in technical systems is recognized as a major source of failure in establishing and maintaining structural integrity. It frequently leads to high maintenance and inspection costs, increasing loss time and excessive retrofit requirements. Thus, durability and safety considerations relate to the presence of fretting fatigue. The reasons for the increasing incidence of such failures are the greater demands placed on components, closer tolerances, and the scaling up of existing plant to a point where movement at mating surfaces exceeds the critical amplitude for fretting.

Though intensive research activity will certainly clear up many problems concerning fretting fatigue in the near future, one practical question which will still be asked by engineers, remains: 'Can fretting fatigue be entirely eliminated by careful design?'

The opinion of Waterhouse /1/ is, that like fatigue it will be impossible to avoid fretting fatigue but its effects can be minimized.

As the conditions of the contacting surfaces has been recognized as an important factor in the fretting fatigue process, a research program was started to provide information regarding the effects of surface conditions caused by mechanical surface treatments and fretting fatigue behaviour. The primary purpose of this research is to determine the effect of different surface treatments of steel specimens on their fatigue and fretting fatigue behaviour.

The initial phase of the research investigation was consumed in the development of an experimental apparatus for the study of fretting fatigue. The following sections describe the projected test method and the main components and functioning of the experimental apparatus.

/1/ R.B. Waterhouse, Fretting Fatigue, Materials Science and Engineering, 25 (1976) 201-296

2. Experimental objectives

The behaviour of two surfaces in contact under load, i.e. whether they behave elastically or plastically, depends to some extent on the surface roughness and stress state. These surface conditions are changed by surface treatments. As mating surfaces of structural parts are treated in a certain way, it is important for service life whether the surface treatment decreases or increases the resistance against fretting fatigue initiated damage. In the projected investigation, specimens of steel should be tested in a comparative manner under both uniaxial fatigue loading and uniaxial fatigue loading with superimposed fretting. Particular attention should be paid to those processes which lead to a nucleation of fatigue cracks, whereas the process of crack propagation is considered to be of minor interest because the state of surface is of less influence on crack propagation. Through variation of parameters of the mechanical surface treatment (grinding, polishing) information should be gained which are of high interest for the field of practice as they indicate steps to reduce damage by fretting fatigue.

In addition to the standard methods to measure normal and tangential forces, stresses, displacements etc. the effects should be studied by electric, magnetic and thermal measuring technics. It is believed that additional insight could be achieved with regard to the fretting fatigue process from these special measurements. The magnetic and electric measuring methods should be utilized for the nondestructive and continuous detection of the damaging processes. Thus the given possibility of the early detection of a stress induced damage of material should permit the experimental detection of the elementary processes which leads to fretting fatigue damage by further methods of investigation. As the behaviour of two surfaces in contact under load depends to some extent on the surface topography or the surface roughness, the surface topography and its change caused by cyclic stressing should be investigated by means of light and scanning electron microscope and roughness measurements. Determinations of surface hardness according to different numbers of loading cycles inform about the state of strain hardening.

3. Experimental approach

To investigate the influence of surface treatments on fretting fatigue, the fretting fatigue conditions occurring in practice were simulated in laboratory testing by model tests. This method is a more economical way to be successful than the method of cost and time expensive direct tests (test of practice). The model test is concentrated on the phenomenon 'fretting fatigue'. Thus the elementary damaging processes should be directly accessible by experiment.

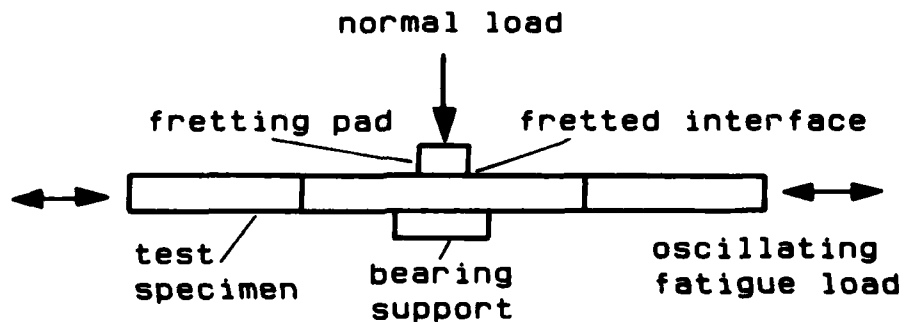

Fig. 1 - Schematic diagram of fretting fatigue test setup

Figure 1 shows diagrammatically a typical fretting fatigue situation, in this case the test setup used for the experiments. This configuration simulates a structural joint in which members represented by the test specimen and the fretting pad are attached by mechanical fasteners. The normal load gives a contact pressure at the fretted interface representing what would be created by the fasteners. In such a situation the fretting accelerates fatigue crack initiation and also the early stages of crack growth.

4. Specimens

A basic objective of the experimental work is to use materials and test conditions similar to those found in practice. Thus ferromagnetic steel should be selected for both the axially loaded test specimens and the fretting pads which touch the flat specimen on one side. The practical system which should be simulated by model tests are the systems gear flange/shaft and bearing race/shaft. Thus it is chosen as material for specimen the shaft steel German Standard W.No.1.6582 which has no AISI equivalent. The gear steel German Standard W.No.1.5752 (AISI 9314) and the bearing steel German Standard W.No.1.3505 (AISI 52 100) are selected as material for fretting pads.

The heat treatment of the materials should be the same as in practice. The contact surfaces of specimens and pads should be polished so that pads and specimens will have the same surface roughness.

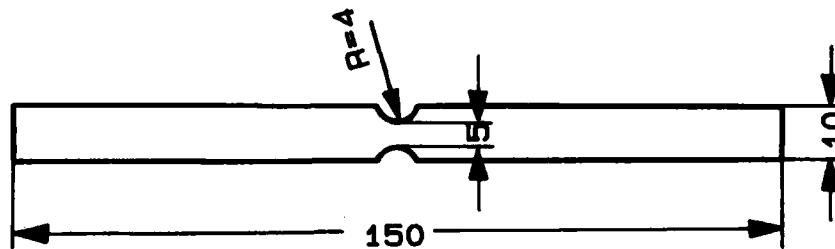

Fig. 2 - Test specimen. 5 mm thick. (dimensions in mm)

The temporary specimen geometry is shown in Fig. 2, the fretting pad in Fig. 3. The cylindrical fretting pad touches the specimen with its shell along a line contact. Comparative tests without fretting should be also conducted on specimens of the same design.

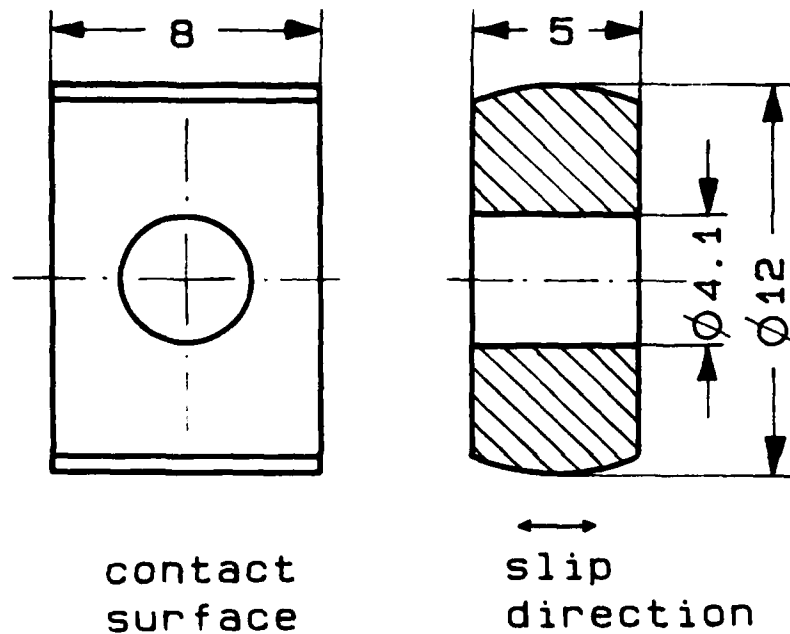

Fig. 3 - Fretting pad (dimensions in mm)

5. Test apparatus

The fretting fatigue machine was developed to meet the following requirements:

1. The fatigue load would be applied axially.
2. The mean load, alternating load, normal load, relative surface displacements, friction load, and frequency would be controllable and monitored throughout each test.

It was decided that the basic fatigue unit should be an electrohydraulic servocontrolled unit to provide the greatest versatility and sensitivity. Consequently, a servo hydraulic testing machine under closed loop control is used to apply axial loads to the specimen. The peak load of the testing machine is 40 kN. The frequency of the push pull loading ranges from 0 Hz to 150 Hz. The load unit assembly consists of a two-column load frame, a servo-hydraulic actuator, and a strain gage load cell. The strain gage load cell is mounted on the crosshead to sense load and produces an electrical signal for readout and switchable feedback in the servo control loop. Hydraulically actuated grips provide self-aligning of the specimens with rapid specimen insertion. Chucks with insulating layers allow to isolate the gripped specimen from the testing machine. This is advantageous for the measurement of the electrical contact resistance of the fretting system.

In order to induce fretting in addition to the axial fatigue loads applied by the hydraulic actuator a fretting arrangement was designed which is shown in Fig. 4.

This arrangement is based on the bridge principle with one foot of the bridge anchored on the upper specimen grip so that all the movement occurs at the other foot. The unfixed lower end of the bridge carries the cylindrical fretting pad, which touches the midsection of the specimens frontside. The midsection of the specimen is supported from the backside by a PTFE block to prevent bending and fretting on the backside of the fatigue specimen. The clamping load is applied to the bridge at its end by a proving ring (not described in Fig. 4). The friction parameters - normal and tangential force and the wear rate - were measured by the strain gauge technique. The slip amplitude is changeable by variation of the length of the fretting bridge by means of distance rings mounted between the ring fastener and the grip on the fixed side of the bridge. A direct measurement of slip amplitude is provided for by capacitance gauge technique.

It is possible to insert a coil system into the fretting device for the nondestructive detection of damage (cracks) in an early stage by means of magnetic induction.

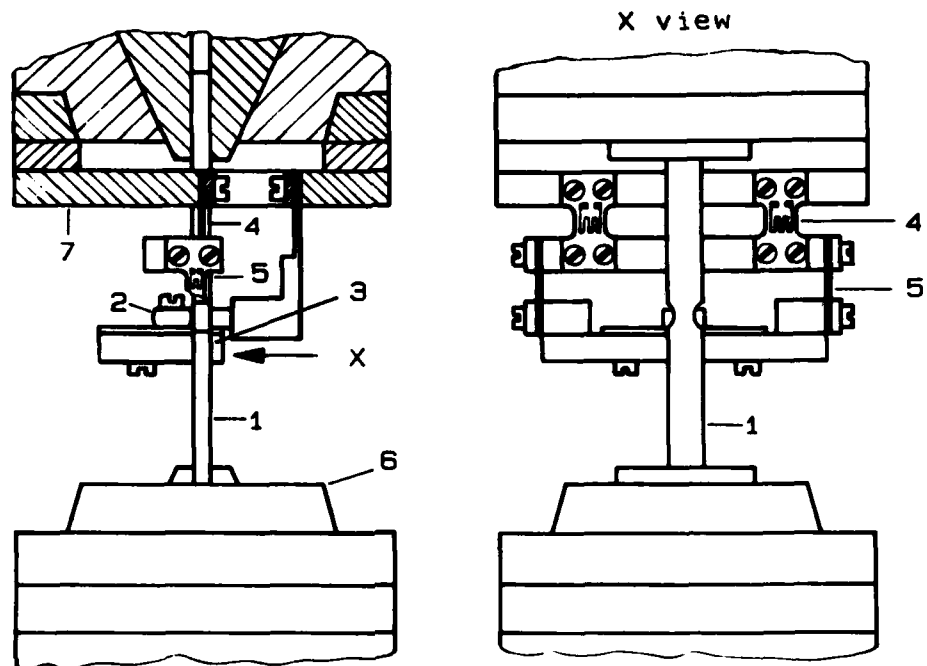

Fig. 4 - Schematic diagram of test apparatus
 1 specimen, 2 fretting pad, 3 support bearing,
 4 guide springs with strain gauges for measurement of linear abrasion, 5 guide springs with strain gauges for measurement of tangential force, 6 hydraulically actuated grips of the servo hydraulic testing machine, 7 ring fastener for the fretting device

6. Control of experiments and data acquisition

The process of damage due to fretting fatigue is influenced by a large number of variables. To investigate the damaging processes by experiments numerous adjustments of test parameters and single measurements of various variables are necessary. This task of measurement is performed most effectively by a largely automatic control of the experimental arrangements by computer. Some of the benefits that can be provided by computerized testing are:

- Improved accuracy
The repeatability of the tests is increased because the test is controlled by a computer program and not by an operator, thus eliminating many human errors.
- Improved efficiency
Less time is required for test monitoring and data reduction. Fewer tests are required, for they are run right the first time and the significant data are properly recorded.
- More versatility
Instead of separate equipment being required for specific tasks the computerized system can be used. When testing requirements change, only the computer program is to change, and not the hardware.
- Increased capability
With a computer in the system, the ability is given to complete tests that may be impossible to perform with reasonable accuracy in any other way.

Considering these facts the control of experiments and data acquisition is mastered by an automatic data acquisition system. The instrumentation side of the system provides a multiplexing scanner. Analog inputs switched by the scanner are connected to a voltmeter for measurement and conversion to a digital signal. Two voltmeters

are provided for in the system to cover a wide range of measurement, speed, accuracy, and resolution. The central control unit is the programmable desk top computer HP 9825 T. This computer controls the experiments and measurements being made, processes the acquired data, and outputs the results in a suitable format. A thermal printer and a graphics plotter belong to the peripheral side of the data acquisition system.

7. Conclusion

The first year of the projected investigations was consumed to design an experimental arrangement suitable for the study of fretting fatigue. A tribological loading system with measuring device to determine the mechanical standard parameters was developed. Computer programs were made for fretting fatigue tests to measure the mechanical parameters characterizing the pad-specimen system after predetermined numbers of loading cycles. Preliminary tests run satisfactory. The next steps are to insert the possibility of crack indication by the magnetic induction method and the measurement of the electrical resistance into the experimental program. To get information about the thermal conditions of the interface region the application of infrared microscope and thermocouple elements should be proved.

Acknowledgments

The author acknowledges the continuing support of the European Research Office of the U.S. Army (ERO) and expresses appreciation to Dr. Robert C. Bill of the Lewis Research Center for his interest and advices. Thanks are also given to Milka Javor for her work due to solve material problems and Lothar Scherpinski for his assistance in constructing the entire system.

