

AD-A140 941

U.S. Department  
of Transportation  
**United States  
Coast Guard**



---

# MARINE CASUALTY REPORT

## SS OGDEN WILLAMETTE: MAJOR ENGINE ROOM FLOODING

IN THE CARIBBEAN SEA,

OFF OF THE SOUTHEAST COAST OF JAMAICA

ON 16 JUNE 1982

WITH PERSONNEL INJURY

DTIC  
SELECTED  
MAY 9 1984

U. S. COAST GUARD

A

MARINE BOARD OF INVESTIGATION REPORT

AND

COMMANDANT'S ACTION

REPORT NO. USCG 16732/0210

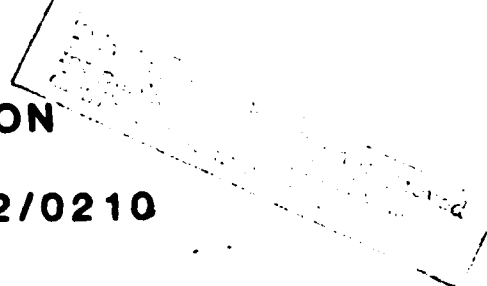

DTIC FILE COPY

84 05 08 001



TECHNICAL REPORT STANDARD TITLE PAGE

1. Report No. USCG 16732/0210	2. Government Accession No. AD-A140941	3. Recipient's Catalog No.	
4. Title and Subtitle Marine Casualty Report SS OGDEN WILLAMETTE, O.N. 518738; major engine room flooding in the Caribbean Sea, off the southeast coast of Jamaica, on 16 June 1982, with personnel injury		5. Report Date 10 May 1983	6. Performing Organization Code G-MMI-1/14
		8. Performing Organization Report No. 16732/0210	
7. Author(s)		10. Work Unit No.	
9. Performing Organization Name and Address U. S. Coast Guard Washington, D. C. 20593		11. Contract or Grant No.	
		13. Type of Report and Period Covered Marine Casualty Report 16 June 1982	
12. Sponsoring Agency Name and Address Commandant (G-MMI-1/14) U. S. Coast Guard Washington, D. C. 20593		14. Sponsoring Agency Code	
		15. Supplementary Notes	
<p>16. Abstract</p> <p>At or about 0200 on 16 June 1982, the SS OGDEN WILLAMETTE, on a loaded voyage, suffered major engine room flooding approximately 47 miles southeast of Morant Point, Jamaica in the Caribbean Sea. With the vessel sinking and the possibility of a boiler explosion, the master ordered abandon ship. Within an hour the entire crew was rescued by the Chilean freighter COPIAPO. At daylight on 16 June 1982, the OGDEN WILLAMETTE remained afloat with her stern awash. It was towed to an anchorage ½ mile off of the southwestern tip of Little Cayman Island. There, the engine room was dewatered and the cargo was lightered to the tankship ESSO ZURICH (Panama). Finally it was towed to New Orleans, LA where repairs were made.</p> <p>This report contains the U. S. Coast Guard Marine Board of Investigation Report and the Action taken by the Commandant to determine the proximate cause of the casualty and the recommendations to prevent recurrence.</p> <p>The Commandant has concurred with the Marine Board that the proximate cause of the casualty was that the low sea suction non-metallic expansion joint failed. The Coast Guard is preparing specific guidance regarding the inspection of expansion joints.</p>			
17. Key Words Expansion joint, sinking, stability, non-metallic, circulating pumps, sea suction, overboard, discharge, flooding rupture, auxiliary condenser, neoprene, engine room		18. Distribution Statement This document is available to the public through the National Technical Information Service, Springfield, Virginia 22121	
19. Security Classif. (of this report) UNCLASSIFIED	20. Security Classif. (of this page) UNCLASSIFIED	21. No. of Pages	22. Price



16732/OGDEN WILLAMETTE

10 MAY 1983

Commandant's Action

on

The Marine Board of Investigation convened to investigate major engine room flooding on the SS OGDEN WILLAMETTE in the Caribbean Sea, off of the southeast coast of Jamaica, on 16 June 1982, with personnel injury

The report of the Marine Board of Investigation convened to investigate the subject casualty has been reviewed; and the record, including the findings of fact, conclusions and recommendations, is approved subject to the following comments:

COMMENTS ON CONCLUSIONS

1. Conclusion 12: This conclusion is not concurred with. As indicated in findings of fact 34, circulating water in the auxiliary condenser was "lined up as standard operating procedure" and this in itself was not a failure to follow proper procedures. If the valve is left open, then the system it services should be routinely checked as stated in conclusion 14.
2. Conclusion 13: This conclusion is concurred with in principle. Diligence or good engineering practice in this case should have included routine checks of the operating machinery including the main and auxiliary condensers and of the bilges by both the midnight to 0400 oiler and watch engineer prior to relieving the watch. However, calculations of the approximate rate of flooding render questionable whether leakage could have been detected by the oiler when he made his rounds between 2350 and 0010.

ACTION ON RECOMMENDATIONS

1. Recommendation 1 is concurred with. A copy of this report will be provided to the U. S. Maritime Administration.
2. Recommendation 2 is concurred with. A suitable article detailing the particulars of this incident will be prepared by the Marine Investigation Division for publication in the Proceedings of the Marine Safety Council.

10 MAY 1983

3. Recommendation 3 is not concurred with. This type of casualty does not appear to be common in the industry. Industry operating guidelines should provide for the maintenance or replacement of expansion joints when necessary. Improved inspection procedures as noted in the comments to recommendation 4 should provide for early detection of potential expansion joint failures.

4. Recommendation 4 is concurred with. The Marine Inspection Division is preparing specific guidance regarding the inspection of expansion joints which will be promulgated as a change to the Marine Safety Manual, CG-495. The Marine Safety Manual change will include the list of items to be looked for during the routine visual examination of expansion joints as contained in Appendix I to the casualty report or similar information.

5. Recommendation 5 is concurred with in part. A copy of this report will be provided to OGDEN MARINE, INC. for their consideration of initiating a training program for its engineering personnel on watchstanding.

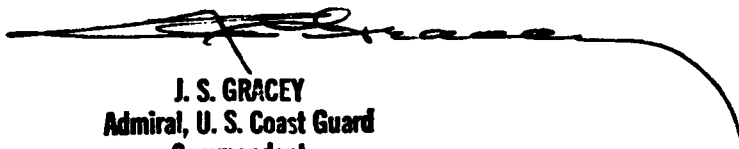

**J. S. GRACEY**  
Admiral, U. S. Coast Guard  
Commandant



DEPARTMENT OF TRANSPORTATION  
UNITED STATES COAST GUARD

U. S. Coast Guard  
Washington, D.C. 20593

16732/SS OGDEN WILLAMETTE  
.15 December 1982

From: Marine Board of Investigation  
• To: Commandant (G-MMI)

Subj: SS OGDEN WILLAMETTE, O.N. 518738; major engine room flooding in the Caribbean Sea, off of the southeast coast of Jamaica, on 16 June 1982, with personnel injury

Findings of Fact

1. At or about 0200 (all times are +4 zone description and are based on a 24 hour clock) on 16 June 1982, the U. S. tankship OGDEN WILLAMETTE, on a loaded voyage, suffered major engine room flooding approximately 47 miles southeast of Morant Point, Jamaica in the Caribbean Sea. With the vessel sinking and the possibility of a boiler explosion, the master ordered abandon ship. Within an hour the entire crew was rescued by the Chilean freighter COPIAPO. At daylight on 16 June 1982, the OGDEN WILLAMETTE remained afloat with her stern awash. In an attempt to salvage the vessel, nine crewmen from the COPIAPO went to the OGDEN WILLAMETTE to make up towing lines. All lines subsequently parted. On 18 June 1982, the vessel was again taken in tow, this time by the MV SMIT SALVOR (Netherlands), a salvage tug. It was towed to an anchorage 1/2 mile off of the southwestern tip of Little Cayman Island. There the engine room was dewatered and the cargo was lightered to the tankship ESSO ZURICH (Panama). Finally it was towed to New Orleans, LA where it is currently undergoing major repairs to the engine room. One personnel injury, no loss of life, and no significant incidence of pollution resulted from this casualty.

2. Vessel data:

Name	OGDEN WILLAMETTE
Official Number	518738
Service	Bulk oil carrier
Gross Tons	20,884
Net Tons	16,422
Dead Weight Tons	37,853
Length Overall	660.17 feet
Length (between perpendiculars)	632.3 feet
Breadth (molded)	90.0 feet
Depth (molded)	48.86 feet
Propulsion	Steam turbo-reduction
Horsepower	15,000 shaft horsepower
Homeport	Wilmington, DE
Owner	Ogden Willamette Transport, Inc. 100 W. 10th St. Wilmington, DE 19801
Operator	Ogden Marine, Inc. 280 Park Ave. New York, NY 10017



It's a law we  
can live with.

**Date Built** 1969  
**Where Built** Sparrows Point, MD  
**Built by** Bethlehem Steel Corporation  
**Master** Jack Ferguson  
2714 Fern Forest  
Houston, TX 77044  
**Licensed as** Master, steam and motor vessels, any gross  
tons, upon Oceans, and radar observer  
**License Number** 495337, issue 4-6  
**MMD Number** 1032639-D1

**Certificate and Inspection Data:**

**Last Certificate of Inspection**

**Date of Issue** 20 March 1982  
**Place of Issue** Jacksonville, FL  
**Date of Expiration** 20 March 1984

**US Coast Guard Cargo Ship Safety Equipment Certificate**

**Date of Issue** 20 March 1982  
**Place of Issue** Jacksonville, FL  
**Date of Expiration** 20 March 1984

**Last Credit Drydock** 20 March 1982  
**Port** Jacksonville, FL

**3. Vessel description:**

The OGDEN WILLAMETTE is of steel construction and has a typical tankship configuration with an after deck house containing the navigating bridge, radio room, and quarters for the entire complement of crew. These quarters are located directly over the machinery spaces. The ship is divided longitudinally into five cargo sections. Each of the five sections has a center tank with port and starboard wing tanks for a total of fifteen individual cargo tanks. There is additional subdivision in the form of peak tanks, forward deep tank, fuel oil tanks, pumproom, and engine room.

4. a. The engine room is located from frame 30 to frame 48, and has eight levels, one at the main deck, three above the main deck, and four below the main deck. The bilges of the engine room are directly over the double bottom tanks. These tanks are 6 feet 6 inches in height. They were originally designed for the carriage of fuel oil but have been empty for the past six to eight years. Directly above the bilges is the lower level where various machinery is located. On the starboard side forward are the: #1 and #2 main circulating water pumps, air conditioning cooling water pump, #1 and #2 salt water service pumps, #1 and #3 main cargo pumps, and #1 cargo stripping pump. On the port side forward are the: #1 and #2 main condensate pumps, #1 and #2 fresh water drain transfer pumps, fire and tank cleaning (Butterworth) pump, #2 and #4 main cargo pumps, and #2 cargo stripping pump. On the starboard side aft are the: #1 and #2 lube oil service pumps, lube oil purifier, emergency lube oil pump, and bilge pump. On the port side aft are the: #1 and #2 fuel oil service pumps, fuel oil transfer pump, and #1 and #2 main feed pumps. There are also numerous motor controllers for the associated pumps throughout the lower level.

b. Above the lower level is the generator flat. It is 14 feet 6 inches above the tank tops. The #1 and #2 600-kilowatt turbo-generators are located on the starboard side and the distilling plant is located on the port side. Two air compressors are along the after bulkhead. The operating platform is on the next level. This flat is 24 feet above the tank tops. Located there is the central control board, the main switchboard, the emergency batteries, and numerous power panels. The next flat is 33 feet above the tank tops, and directly above that is the upper deck, which is in line with the main deck. Above the main deck level is the poop deck, the boat deck, and the bridge deck, respectively.

5. The main propulsion plant of the OGDEN WILLAMETTE is semi-automated. The main boilers were manufactured by Foster Wheeler Corporation and have a 700 psi maximum allowable working pressure. The #2 turbo-generator is the main generator. It exhausts, under vacuum, directly into the main condenser. The #1 turbo-generator is the standby generator. It exhausts into the auxiliary condenser which is an atmospheric exhaust condenser.

6. In the main circulating water piping system, there are ten valves associated with the main and auxiliary condensers. They are:

Main Condenser	Valve Size (in inches)
Main Circulating Pumps Low Sea Suction (butterfly valve - gear operated)	26
Main Circulating Pumps High Sea Suction (butterfly valve - gear operated)	26
Main Condenser Overboard Discharge (butterfly valve - gear operated)	24
#1 Main Circulating Pump Suction (wafer type butterfly valve - gear operated)	20
#2 Main Circulating Pump Suction (wafer type butterfly valve - gear operated)	20
#1 Main Circulating Pump Discharge (wafer type butterfly valve - gear operated)	18
#2 Main Circulating Pump Discharge (wafer type butterfly valve - gear operated)	18
Main Bilge Suction Valve (stop-check valve)	18
Auxiliary Condenser	
Circulating Water to Auxiliary Condenser (wafer type butterfly valve - gear operated)	12
Auxiliary Condenser Overboard Discharge (butterfly valve - gear operated)	12

7. The auxiliary condenser is positioned athwartships, at frame 46, 12 feet above the tank tops, on the centerline. The main condenser and reduction gear are located aft of the auxiliary condenser. The main bilge suction valve is located immediately aft of and connected to the suction piping of the #2 main circulating pump. The sea chest for the low main sea suction is located at frame 46, 9 feet 6 inches above the keel on the starboard side. The low main sea suction valve is just in-board of the sea chest followed by a waster piece and a non-metallic expansion joint.

The high main sea suction piping branches into the line at that point, and has the same components. From there the line branches off again, one section to each main circulating pump. Each pump has non-metallic expansion joints, in line, immediately to either side. The main condenser overboard discharge valve is located at frame 40, 18 feet above the keel on the starboard side. The circulating water to the auxiliary condenser flows through a 12 inch branch line off of the main condenser circulating water piping. This branch begins between the #1 main circulating pump and its associated discharge valve. The auxiliary condenser inlet valve is in line and located in the vicinity of the #2 main circulating pump. The auxiliary condenser overboard discharge valve is located on the port side at frame 45, 14 feet 6 inches above the keel.

8. A Class-2 (sliding) watertight door is located in the aft watertight bulkhead of the engine room on the starboard side, lower level. This door connects the shaft alley and the engine room and is operable locally, by handgear, from either side or, remotely by handgear, from a station located outside the crew's mess, four decks above. All three stations are geared mechanically to the door with no hydraulic assist. This door is normally kept open while the vessel is underway. The emergency fire pump is located in the shaft alley. This pump also functions as a bilge pump to take a suction on the shaft alley bilges and/or the engine room bilges. In the after end of the shaft alley is the emergency escape. It leads up to the after steering gear compartment and from there to the fantail on the main deck. At the time of the casualty the vessel was manned by a crew of thirty-four (34) including the Master.

9. Person injured:

As a result of this casualty the following individual sustained injury in excess of 72 hours:

Name	Edsel Sholar
Position on Vessel	Third Assistant Engineer
License Number	527582

PII Redacted

10. Cargo data:

On 11 June 1982, the vessel completed loading a cargo of Alaskan crude oil (Alaskan North Slop Crude) at Puerto Armuelles, Panama, South America. 264,007 net barrels were loaded at a temperature of 78 degrees Fahrenheit for the charter party Exxon, USA.

The cargo tanks were loaded with the following ullages:

Tank	<u>Port</u>			<u>Center</u>			<u>Starboard</u>		
	<u>ft.</u>	<u>in.</u>	<u>bbls.</u>	<u>ft.</u>	<u>in.</u>	<u>bbls</u>	<u>ft.</u>	<u>in.</u>	<u>bbls</u>
1	3	11-1/4	12,703	19	1-1/2	24,088	3	11-1/2	12,697
2	3	11-3/4	16,744	6	0-1/2	33,475	3	11	16,877

Tank	Port			Center			Starboard		
	ft.	in.	bbls.	ft.	in.	bbls.	ft.	in.	bbls.
3		Empty		14	9	27,197		Empty	
4	4	10	16,955	4	11-3/4	34,186	3	11	16,925
5	3	11-3/4	15,280	4	9	28,012	3	11-1/4	15,292

Note: No. 3 port and starboard wing tanks are segregated ballast tanks.

11. Last voyage:

After completing cargo loading operations in Panama, the draft readings were: 36 feet 6 inches forward, and 37 feet 6 inches aft. The vessel got underway from the anchorage in Balboa, at 0240, 14 June 1982. At 1454 on 14 June 1982, the vessel departed the Panama Canal, and proceeded at full speed (15.55 knots), bound for Bayway, NJ. The voyage continued uneventfully for approximately 33 hours until midnight on 15 June 1982. The existing weather conditions at that time were: winds easterly at 22-27 knots, seas easterly at a height of 6 to 8 feet, with moderate swells. The vessel was occasionally taking seas over the starboard side amidships. There were scattered clouds and good visibility. The barometric pressure was 29.89 inches and rising. The air temperature was 80 degrees Fahrenheit. The sea water temperature was 81 degrees Fahrenheit.

12. a. The engine room watch crew consists of two men, an assistant engineer and an oiler. On 15 June, the 2000 to midnight watch was Third Assistant Engineer Edsel Sholar and Oiler Joseph Arch. According to the oiler, the machinery in operation at the time he went off watch that evening was:

- #1 Main Condensate Pump
- #1 Drain Tank Pump
- #2 Evaporator Feed Water Pump
- #1 Main Feed Pump
- #2 Fuel Oil Service Pump
- #1 Main Lube Oil Pump
- #1 Main Circulating Pump
- #2 Main Circulating Pump
- #1 Salt Water Service Pump
- Air Conditioning Cooling Water Pump
- #2 Ship's Service Turbo-Generator
- #1 Main Propulsion Boiler
- #2 Main Propulsion Boiler
- #1 Lube Oil Cooler

The main condenser was taking its suction from the main high sea suction and discharging through the overboard discharge. Both engineer and oiler conducted their normal engine room watch.

b. There are four bilge suction lines in the engine room, and one in the shaft alley, all of which feed into the bilge pump. At 2300, the oiler operated the engine room bilge pump. It was common practice for the oiler to pump the bilges down to as low a level as possible before completing a watch. At the time, there were four to five inches of water in the bilges which he was able to get down to

two or three inches before the level went below that of the suction intake. The oiler then secured the pump and the suction line, finished his round, and returned to the operating platform. The remaining water was located in the forward part of the bilges due to the fact that the vessel was very nearly on even keel. At about 2335 the third assistant made the last round of the engine room for his watch. He inspected the bilges and noted nothing unusual.

13. The casualty:

At approximately 2345, the watch engineer was relieved by Third Assistant Engineer Jesse Melton. Sholar told the relieving engineer that he had had no problems. At the same time, Andrew Lewis, the midnight to 0400 oiler, relieved Arch. Arch told Lewis that everything was under control. At approximately 2350, the midnight to 0400 oiler commenced his engine room rounds. He checked the generator, the fuel oil temperature, and the lube oil purifier. He also checked the temperature on the main condenser overboard discharge and examined with a flashlight the bilge area in the vicinity of the cargo pumps on the starboard side. Two to three inches of water were observed in the bilges under the cargo pumps. This was considered to be from leakage which normally occurred in the engine room. He then checked the feed pumps and the fuel oil service pump on the lower level, the evaporator on the generator flat, and then made his way back to the operating platform via the port side aft ladder. The time was approximately 0010, 16 June 1982.

14. Immediately thereafter, the watch engineer commenced his normal engineering rounds. He went down to the generator flat to check the generator oil pressure and bearing temperatures. Next he descended the ladder to the lower level. It was at this time he noticed the first indication of a problem. He saw water almost over the top of the cargo pumps and immediately returned to the operating platform and instructed the oiler to start the bilge pump. He then called First Assistant Engineer Timothy Manning on the phone and informed him of the situation. The first assistant instructed him to call Chief Engineer Ronald Schwartz and apprise him of the situation.

15. The oiler came down the starboard ladder aft to the lower level and saw water halfway up the cargo pumps, a height of approximately three feet above the double bottom tank tops. He opened the starboard side after bilge suction valve and energized the pump. He then crossed over to the port side aft and opened that bilge suction valve. From there he moved forward on the port side to where the forward port and starboard bilge suction valves are located. He was unable to open the starboard valve without a wrench. It was at about that time he heard the General Alarm sound. Fearing that the lights would go out, he ran up to get a flashlight. He returned and was able to complete opening the suction valve on the port side but not the one on the starboard side. Next he heard the Chief Engineer yell, "Everybody get out of the engine room ", and left immediately.

16. The chief engineer recalled that he received the call from the third assistant at 0015 and was in the engine room by 0016. Immediately he went down to the generator flat and had started down to the lower level when he saw the water. He estimated it to be three to four feet deep. The water was entering the motors on the main circulating pumps. He returned to the operating platform and ordered all stop. The first, second and third assistant engineers had been right behind the chief in reaching the engine room. The first assistant sounded the General Alarm as the two third assistants cut out the inboard burner to each boiler.

17. Many of the electrical motors in operation down below were suddenly shorting out due to the rapidly rising water. The generator had numerous grounds and was surging; it was purposely tripped off the line. When this occurred, fires were lost in both boilers and steam pressure began to drop. The emergency diesel generator automatically came on line to provide emergency lighting and power. After the chief engineer ordered everyone out of the engine room, he proceeded to the lower level. Water was surging back and forth with the roll of the vessel and he could not find anything indicating the source of this flooding. He checked the low main sea suction to see if it was closed, which it was. He secured the high main sea suction valve and the main condenser overboard discharge valve. He believed that if the problem was in this main system, closing those valves would stop the influx of water. The main circulating pump motors had shorted out. He did not attempt to open the main bilge suction valve. He then went to the shaft alley door and began to close it with the local handwheel but:

By this time the smoke from the burning insulation and so forth was getting to me to the point where I thought it would be wise to get out before I stayed there permanently.

18. He left with the door in the open position, having closed it only a few inches. While he was there, water was beginning to enter the shaft alley over the threshold of that door. He went up to where the crew was gathered, in the crew's passageway, and instructed Oiler Paul Adams to get another man and finish securing the shaft alley watertight door from the remote station. He also instructed the first assistant to obtain help and enter the shaft alley by the emergency escape route to place the emergency fire and bilge pump on the line. Adams went to the starboard side second deck with Arch and Lewis to secure the shaft alley door. According to Adams, there were no problems experienced closing the door, and as far as he could tell, it was completely secured. He then went aft to the fantail where the first assistant instructed him to go down and put the emergency fire pump on the bilge system to the engine room. Adams and Carlos Weekley, the second pumpman, went through the steering gear compartment and down through the emergency escape into the shaft alley.

19. The chief engineer at this time went up to inform the master of the rising water and their attempts to stop it. The Chief Mate, Michael Staikoff, with the assistance of the boatswain and two other crewmembers, checked compartments and spaces throughout the vessel to further ensure watertight integrity. They examined the following spaces and found them to be secure: the fore and aft peak tanks (empty), all of the cargo tanks, and the cargo pumproom. They did detect the sound of slight leakage into the cargo pumproom.

20. In the shaft alley the water had risen above the level of the deck plates to a point where it was entering into the fire pump motor. The oiler attempted to start the pump by lining up the valves and pushing the start button on the controller. When this did not work, the first assistant instructed Sholar to use the reset switch located outside the main deck entrance to the steering gear compartment. This method also failed. During this time, the oiler and the second pumpman observed water coming into the shaft alley from the vicinity of the watertight door. From the shaft alley, the door appeared to be ajar along the leading edge of the upper lefthand corner. A steady flow of water was coming in from this apparent opening. Shortly thereafter, Sholar began experiencing sudden chest pains and shortness of breath; the chief mate and second assistant administered oxygen and

the other third assistant gave him some glycerin tablets. When his condition did not improve, it was feared that he had suffered a heart attack.

21. Attempts to start the emergency fire pump proved unsuccessful and the first assistant ordered the oiler and second pumpman to leave the shaft alley. The chief engineer again went to speak with the master and informed him of their unsuccessful efforts to control the ingress of water. The master made the decision to send off a distress message. During this time, the second assistant engineer volunteered to go into the engine room with an air pack to determine the height of the water. He descended to the generator flat where he determined that the water now appeared to be about eight feet above the tank tops. In the radio room, the radio officer transmitted the S.O.S. on 500kHz and activated the auto alarm. The initial broadcast was received by U. S. Coast Guard Radio Station Miami and communications were established. The tanker MORMACSTAR (US) also received the broadcast, but was at least three hours steaming time from the reported position.

22. The first assistant went to the emergency generator room where the chief engineer also arrived, moments later. The diesel was surging, so the first began to clear the switchboard of all non-vital electrical equipment. When the circuit breaker to the emergency fire pump was tripped, the generator ran normally. The first then went down to check the level of water in the engine room. He was standing about 20 feet above the operating platform and observed the water to be about even with the deck of the generator flat.

23. Shortly thereafter the chief mate, chief engineer, and first assistant engineer met in the crew's passageway to confer with the master. He was again apprised of the availability of ship's power, the rising water in the engine room, and now the possibility of explosion if seawater came in contact with the boilers. At that time he made the decision to abandon ship. The four senior officers agreed that they would remain aboard. At about 0140 the master went to the bridge to make distress calls on Channel 16 VHF-FM and was able to make contact with the MV COPIAPO. He radioed his position as 17 degrees, 18 minutes North, 75 degrees and 33 minutes West. The COPIAPO, a general cargo freighter, had sailed from the Panama Canal ahead of the OGDEN WILLAMETTE. It was now about 20 miles to the north and upon receiving the distress message, immediately set course, at full speed, for the radioed position. Her estimated time of arrival was within one hour and twenty minutes. The COPIAPO's master, Captain Chander Gorowara, requested Captain Ferguson to keep in contact every 5 or 10 minutes until he was on scene. In the meantime he called out his crew to prepare for rescue and possible search for survivors.

24. At 0200 the chief engineer and first assistant checked the level of the water in the engine room. It was five to six feet below the bottom of the boilers. They could see the boiler pressure gauge and it appeared that about 200 pounds of steam pressure remained in the boilers. At 0205 Captain Ferguson commenced abandoning the ship, less than two hours after the initial flooding was discovered.

25. The chief mate readied the lifeboats and muster was taken. Due to the wind and sea conditions, the master ordered the crew to abandon the vessel in the #2 lifeboat. He had already ordered the #1 lifeboat lowered to the water in the event that those remaining on board needed an emergency escape. Unfortunately, after the #1 lifeboat was in the water, the forward fall somehow disconnected from its hook. This left it riding on the sea painter and the after fall. In the opinion of the master, the situation rendered this boat unusable if it was needed in an emergency.

26. Third Assistant Engineer Sholar was placed in a litter and, with the assistance of several crewmembers, lifted into the #2 lifeboat at the embarkation deck. The lifeboat was then lowered to the water and the embarkation ladder was used to debark the remaining crew. Captain Ferguson, after discussing the situation with Captain Gorowara, decided that all would leave and that he would return in the morning if possible. The master and chief engineer were the last to leave. The evacuation was orderly and took approximately 25 minutes. The lifeboat was away at 0230.

27. At 0309, the COPIAPO was about 1,000 feet away from the OGDEN WILLAMETTE. The lifeboat was sighted and at 0321, it was alongside the COPIAPO. The entire crew was safely taken aboard. The tanker NIAHOL (Norway) had picked up the MAYDAY and was steaming to the scene. At 0400, the NIAHOL and the MORMACSTAR were informed that the crew had been rescued by the COPIAPO and that they could continue their voyage. The Jamaican Defense Force (JDF) had been put on alert and their assistance was requested to medevac the ailing third assistant. The COPIAPO was subsequently notified that a JDF helicopter was on its way.

28. At daylight on 16 June 1982, the now abandoned OGDEN WILLAMETTE remained afloat, drifting in the Caribbean Sea with her stern awash and the COPIAPO standing by. Her #2 lifeboat had been damaged as it was brought aboard the COPIAPO and the OGDEN's master and chief engineer did not want to risk a transit back to their vessel in it. They approached Captain Gorowara and requested to be returned in a COPIAPO lifeboat. After taking into account the wind and sea conditions, and a radio conversation with his superiors, he denied the request. At 0818 a JDF helicopter expertly landed on the #1 hatch of the COPIAPO from which the ailing third assistant engineer was airlifted to a hospital in Kingston, Jamaica. He was subsequently flown back to the United States and examined by a private physician in his hometown. He was hospitalized for a condition which was diagnosed as a heart attack.

29. At 0940, the COPIAPO lowered away her #2 lifeboat with nine COPIAPO crewmen aboard. Their intent was to take the OGDEN WILLAMETTE in tow for salvage purposes. The crewmen managed to make fast along the port quarter. They used two mooring lines from the COPIAPO and two mooring lines from the OGDEN WILLAMETTE for towing hawsers. These lines were led from the bow of the OGDEN WILLAMETTE to the stern of the COPIAPO. The U. S. Coast Guard Cutter DALLAS (WHEC-716), with USCG helicopter No. 1407 aboard, had arrived on scene and was monitoring the operation. Due to the wave action at the stern of the OGDEN WILLAMETTE, the COPIAPO's lifeboat flooded and became unusable. After securing the towing lines, the crewmen returned to their vessel using the 8 man liferaft from the foredeck of the OGDEN WILLAMETTE. Captain Gorowara then attempted to tow the OGDEN WILLAMETTE in an easterly direction because she was being set towards the Jamaican coast. At 1640, 16 June 1982 one of the towing lines parted. At about 1700 the OGDEN's #1 lifeboat completely broke away from her starboard side. The DALLAS attempted to retrieve the lifeboat but it became swamped, was left awash, and eventually sank. At 2320, another towing line parted and a third towing line parted 5 minutes later. At 0012 on 17 June 1982, the last towing line parted and the vessel was again adrift. Captain Gorowara was then instructed by his superiors to resume his original voyage to Newport News, VA with the survivors. The DALLAS received permission from the Jamaican government to monitor and assist within the Jamaican 12 nautical mile territorial limit if the vessel began to drift toward Jamaica.

30. A Jamaican tug, the PORT ANTONIO, arrived later with the JDF Coast Guard Cutter FORT CHARLES. The tug also attempted to take the vessel in tow. Two men from the

tug were sent to the OGDEN WILLAMETTE to make up towing hawsers. They became stranded aboard when the hawsers became fouled in the tug's screw. Both men were subsequently transferred onto the FORT CHARLES by USCG helicopter No. 1407. Also around this time, the vessel began drifting north and was in no apparent danger of grounding on the Jamaican coast.

31. At 1700 18 June, the MV SMIT SALVOR (Netherlands) arrived on scene. She is a 61.83 meter, 6,000 shaft horsepower, twin screw diesel salvage tug. She secured a tow line on the OGDEN WILLAMETTE and awaited instructions from the vessel's owners. The owners had originally negotiated with the Jamaican government to enter Jamaican waters, but because of the prohibitive cost of the Jamaican government's security bond requirement, the vessel owners decided against it. It was then towed to the Cayman Islands by the SMIT SALVOR accompanied by the MV SMIT LONDON (Netherlands). They arrived and anchored at 1400 on 24 June 1982, 1/2 mile off of the southwestern tip of Little Cayman Island. The vessel was riding high by the bow and had about 1 - 2 feet of freeboard at the stern. She was then boarded by a survey party who noted that the engine room had flooded to a depth of approximately 45 feet, and that the pumproom had flooded to a depth of approximately 5 feet. Divers surveyed the underwater hull in the vicinity of the engine room and discovered two areas that had a surging motion through the hull. These two areas, the main sea chest and the overboard discharge for the auxiliary condenser, were sealed off with temporary patches of polypropylene plastic attached to wooden frames with hook bolts. No other problems were discovered externally.

32. At 0900 on 26 June the salvors commenced dewatering the engine room. This was completed at about 1800 on 29 June. During this operation, the patch on the overboard discharge for the auxiliary condenser apparently broke loose and the water level in the engine room began to rise. One of the salvage crew went down to the overboard discharge valve for auxiliary condenser, saw that it was open, and closed it. This action appeared to stop the water from rising in the engine room. The salvage crew also opened the shaft alley watertight door to facilitate dewatering the shaft alley. After the water level was reduced to a minimum, the survey party descended to the lower level of the engine room. A member of the salvage crew reopened the auxiliary condenser overboard discharge valve and water was heard coming into the engine room from the vicinity of the starboard side main sea chest (see diagram below). Inspection of the piping in that area revealed an approximate eight inch opening in the low main sea suction rubber expansion joint. No other sources of flooding were discovered in the engine room. On 29 June the SS ESSO ZURICH (Panama) was alongside to commence lightering operations. This operation was completed on 4 July 1982, and arrangements were made to tow the SS OGDEN WILLAMETTE to New Orleans, LA. She arrived in the port of New Orleans on 10 July 1982.

33. On 11 July 1982 the Marine Board of Investigation visited the vessel at her berth. The ruptured rubber expansion joint was examined in place by all members of the Board. It was located just above the bilges in an area in which it was difficult to conduct a complete and thorough visual inspection. The rupture, or crack, was on the underside of the joint along the circumference of the arch. The Board also observed that the vessel had received extensive water damage to the main and auxiliary equipment in the engine room. The expansion joint was removed from the vessel to a shoreside facility on 13 July 1982 where it was again examined by the Marine Board. The rupture measured seventeen inches in length and was complete from interior to exterior. The joint generally felt firm except along the arch in way of the crack. This area felt spongy and provided no support for the arch.

Examination of the joint's interior revealed that the tube had delaminated from the carcass. The entire joint was covered with a red substance.

34. From testimony taken by the Marine Board in New Orleans on 12-13 July 1982, it was learned that water was circulating through the auxiliary condenser at the time of the casualty. The standby ship's service turbo-generator, the four main cargo pumps and both cargo stripping pumps exhaust into this condenser. None of the above mentioned equipment was in operation at the time of the casualty. The circulating water was, however, lined up as standard operating procedure. This was done in the event that if there was a sudden failure of the main generator, the watch engineer could simply start up the standby generator without having to line up the circulating water to the auxiliary condenser. The condensate drain back to the drain tank was also left lined up. This, in effect, was considered to be a safeguard. The company had experienced problems in the past when watchstanding personnel inadvertently forgot to line up the circulating water to the auxiliary condenser before putting the generator and/or pumps on the line. Exhaust steam would then enter the condenser without a condensing medium. After the omission was discovered, and the condenser cooling system activated, the condenser would be chill-shocked. As a result, this condenser has had to be retubed several times.

35. An inspection for certification on the SS OGDEN WILLAMETTE was completed on 20 March 1982 in Jacksonville, FL. In conjunction with this inspection, a credit drydock examination was also completed on that date. The hull was inspected externally and internally. During that shipyard period, the American Bureau of Shipping (ABS) was also conducting a survey. The ABS survey included the examination of non-metallic expansion joints. According to the attending ABS surveyor and Coast Guard inspector, the testing of expansion joints consists of using a flashlight and a test hammer to examine flanges, studs, and rubber, for evidence of spongy spots on the surface and leakage and/or deterioration of either the rubber or the flanges. The use of non-metallic expansion joints is permitted by Coast Guard regulations, but there are no written guidelines regarding their inspection, repair, maintenance, or replacement.

36. On 24 March 1982, the OGDEN WILLAMETTE had suffered a malfunction of her rudder assembly. This occurred shortly after departing the shipyard in Jacksonville, FL where work had been completed on the rudder. As a result the vessel was towed to Curacao, Netherland Antilles and drydocked on 2 April 1982. During this drydocking, the vessel had to be refloated on the drydock to facilitate the departure of another vessel that was also in the drydock. She was then redrydocked and repairs to the rudder were completed on 12 April 1982. No other repairs were accomplished during this drydocking.

37. There are sixteen non-metallic joints in the engine room of the OGDEN WILLAMETTE. During the inspection for certification, it was determined that six of them would be required to be renewed. Of the six, only two, the overboard discharge for the auxiliary condenser, and the overboard discharge for the bilge pump, were on the skin of the ship. This low main sea suction expansion joint was examined by the attending Coast Guard marine inspector and ABS surveyor, the port engineer, and the chief engineer. None of them made a determination that it was a potential failure. The joint was manufactured by the Goodall Rubber Company in June of 1968. As far as can be determined, it was original equipment. It was manufactured with red neoprene cover, a black neoprene tube, cotton fabric and a .035 inch x 15 strand x 7/16 inch wide steel bead wire that had a liquor finish.

38. The OGDEN WILLAMETTE is presently berthed at Avondale Shipyard in New Orleans, LA awaiting permanent repairs to the entire engine room under the cognizance of the Officer in Charge, Marine Inspection, New Orleans. Form CG-2752A has been submitted.

1. Main Circ. Pumps Low Sea Suction Valve
2. Low Main Sea Suction Expansion Joint
3. Main Circ. High Sea Suction Valve
4. High Main Sea Suction Expansion Joint
5. Main Condenser Overboard Discharge Valve
6. Main Condenser Overboard Discharge Exp. Joint
7. Main Circ. Pumps Suction Valves
8. Main Circ. Pumps Discharge Valves
9. Circ. Water to Lube Oil Cooler
10. Main Bilge Suction Valve
11. Circ. Water to Aux. Condenser Valve
12. Aux. Condenser Overboard Discharge Valve

A. Other Rubber Expansion Joints in System

Figure 1. Diagram showing the flow of water when the rupture in the low main sea suction expansion joint was discovered by the survey party on 29 June 1982. With the exception of the main bilge suction valve, all numbered valves were open at the time of the casualty.

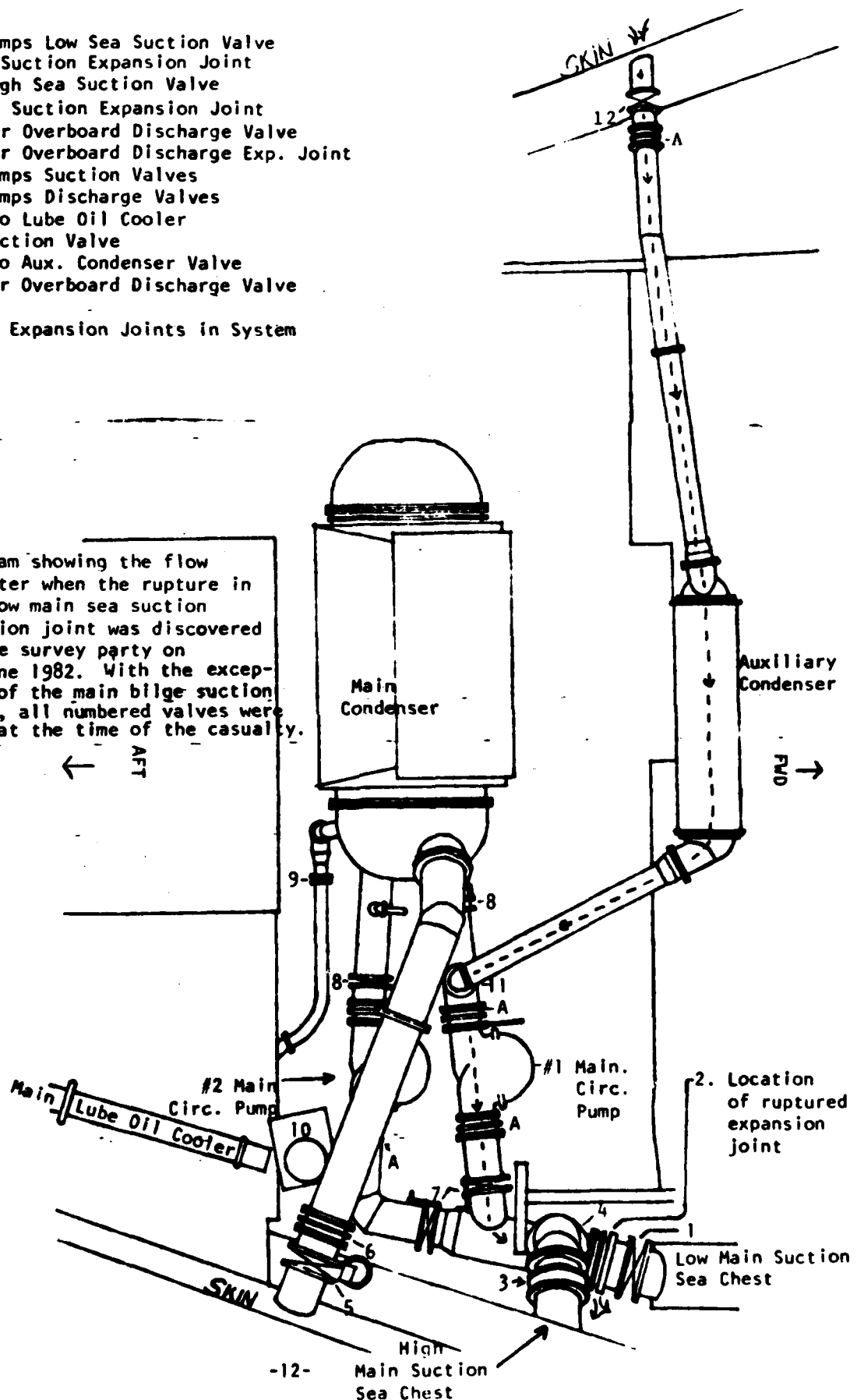

The following pictures show the condition of the low main sea suction non-metallic expansion joint from the SS OGDEN WILLAMETTE sometime after the casualty occurred on 16 June 1982.

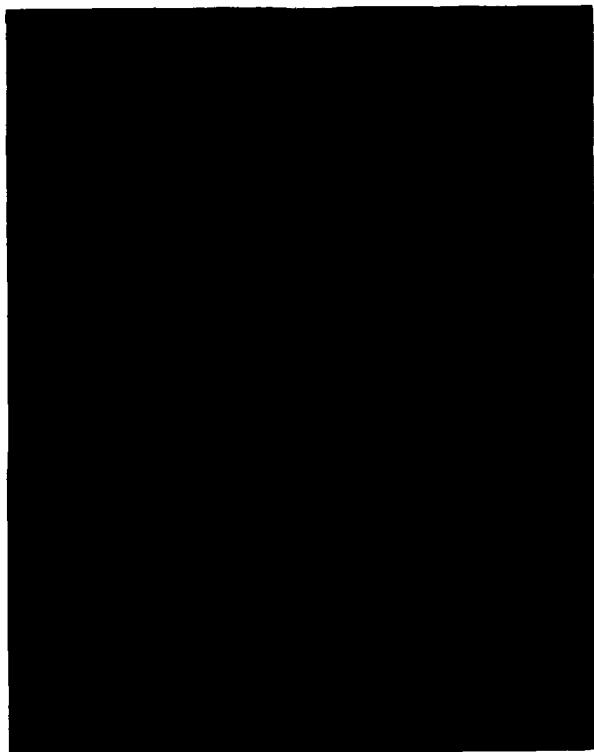

1. Taken in New Orleans on 11 July 1982 while the joint was still in place. Residual water in the system can be seen leaking out of the joint as it flows into the engine room bilges.



2. After the joint was removed to a shore-side facility on 13 July 1982, the Marine Board conducted a thorough examination. The joint measured 26 inches (inside diameter) by 10 inches (flange to flange).

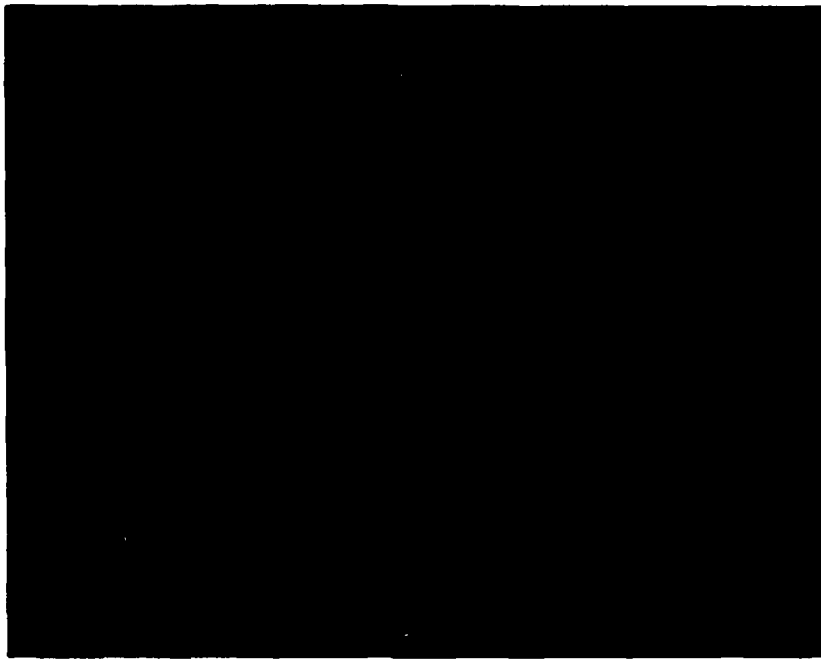

3. The rupture measured 17 inches in length.

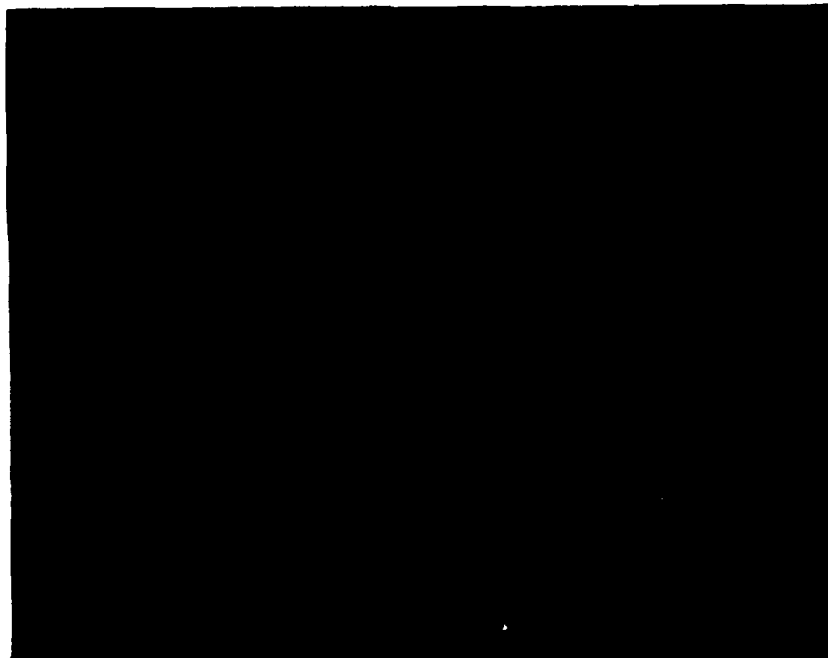

4. From inside, the joint is shown here 180° from its installed position. It can be seen that the tube had delaminated from the carcass.

## Conclusions

1. That the proximate cause of the casualty was that the low sea suction non-metallic expansion joint failed. This caused the normal flow of circulating water from the high sea suction to the main circulating pumps to begin flooding the engine room bilges through the rupture in this joint. The chief engineer subsequently attempted to isolate the main condenser by securing the high sea suction and overboard discharge and by ensuring that the low sea suction was also secured. At this time he was unaware of what was causing the flooding. His actions, which occurred shortly after the initial flooding was discovered, stopped the ingress of water coming from the high sea suction. It is estimated that the level of water in the engine room had already reached 5 - 6 feet.
2. That contributing greatly to the flooding of the engine room was that the auxiliary condenser circulating water inlet and overboard discharge valves were open. The main condenser had been isolated and both main circulating pump motors had shorted out. This then allowed seawater to backflow from the auxiliary condenser overboard discharge, through the auxiliary condenser and #1 main circulating pump, out the rupture in the expansion joint, and into the engine room.
3. That the cause of the partial flooding of the cargo pumproom to a depth of approximately 5 feet, was due to leakage through the watertight bulkhead separating the engine room from the cargo pumproom. This leakage occurred through the shaft packing glands of the 4 main cargo pumps and 2 cargo stripping pumps.
4. That the exact time that this joint failed is unknown. It most probably occurred at or about the completion of the midnight to 0400 oiler's first round at 0010 16 June 1982.
5. That the cause of the rupture of the non-metallic expansion joint was most probably due to natural deterioration. There is no evidence that any of the work completed in either of the two most recent shipyards periods contributing to the casualty.
6. That present procedures concerning the inspection of non-metallic expansion joints did not bring about discovery of the potential failure of this joint does not, in itself, show the inadequacy of such procedures, especially in view of the contributing factors. It does, however, point out the need for better guidelines for inspection and testing and possibly a need for requiring periodic replacement of such joints. The recommendations made by the joint manufacturer concerning the maintenance and inspection of non-metallic expansion joints are a good basis for the guidelines to be followed by the various agencies involved in the inspection of U. S. merchant vessels.
7. That the exact cause of the shaft alley watertight door not completely closing after it was remotely secured cannot be determined. While dewatering operations were being undertaken on 29 June 1982, the salvage crew opened this door without inspecting it, to facilitate dewatering the shaft alley. The most probable cause was that, as water began flowing into the shaft alley from the engine room, solid debris on or beneath the surface of the water became wedged in the doorway as it was being secured, preventing it from closing completely.
8. That the cause of the forward fall unhooking from the #1 lifeboat and the cause of the #1 lifeboat eventually breaking away from the OGDEN WILLAMETTE, cannot be determined due to the fact that the lifeboat sunk before it could be recovered and examined.

9. That the cause of Third Assistant Engineer Sholar's chest pains and shortness of breath was due to the fact that he had suffered a heart attack.

10. That the vessel did not sink was primarily due to the reserve buoyancy provided by the following tanks which were completely empty or slack:

The Fore Peak Tank  
No. 1 Center Tank  
No. 3 Center Tank  
No. 3 Port and Starboard Wing Tanks  
The Engine Room Double Bottoms  
The After Peak Tank

11. That the rescue efforts of the MV COPIAPO are considered to be most commendable and in the best interest and highest tradition of the sea.

12. That this casualty exemplifies the possible problems that can result when proper operating procedures are not followed. The flooding would have been substantially reduced had the auxiliary condenser circulating water not been lined up at a time when the auxiliary condenser was not in use. The safety factor of having an overboard discharge valve on the auxiliary condenser was negated by the fact that this valve was always left open. The watertight integrity of the engine room was reduced by this factor and its results are evident.

13. That this casualty exemplifies the need for more diligent engineering rounds by watchstanding personnel aboard a vessel. Had this been done, the source of this flooding might have been detected before the flooding reached catastrophic proportions.

14. That operating personnel should be aware of the number and location of all skin valves that are in the open position. If the auxiliary condenser overboard discharge valve had been closed by the chief engineer, the ingress of water would have been stopped and the total flooding of the engine room would have been prevented. The proper training of engineering and watchstanding personnel and a thorough knowledge of shipboard engineering systems are a necessary part of the job of the vessel operators and engineering officers aboard a vessel.

15. That if another engineer had remained below to assist the chief engineer, the open valves on the auxiliary condenser may have been detected.

16. That the master's testimony as to the usefulness of the #1 lifeboat after the forward fall disconnected is not concurred with. This lifeboat could have been used if the situation required.

17. That there is no evidence of negligence, misconduct, inattention to duty, or willful violation of law or regulation on the part of any licensed or documented personnel which would warrant further action under the provisions of R. S. 4450.

18. That there is no evidence that any personnel of the Coast Guard or any other government agency caused or contributed to the cause of this casualty.

## Recommendations

1. That a copy of this report be provided to the U. S. Maritime Administration, the government agency having the primary statutory authority for the training of maritime personnel.
2. That this report be widely disseminated for the use of other persons and organizations involved in the training of maritime personnel.
3. That the Commandant consider the feasibility of requiring periodic replacement of non-metallic expansion joints near the skin of the ship. Joints such as these should be required to be renewed after ten years of service.
4. That the Commandant should develop specific guidelines for Coast Guard marine inspectors concerning the use, inspection, testing, maintenance, repair, and/or replacement of non-metallic expansion joints near the skin of the ship. This can be accomplished through the use of existing Coast Guard instructions and/or publications. In particular, as a beginning, the maintenance and inspection guidelines of the manufacturer of this joint, as described in Appendix 1, should be followed.
5. That Ogden Marine, Inc. initiate a training program for its engineering personnel on watchstanding and the proper operation of auxiliary condensers aboard its vessels.

## Appendix I

1. The manufacturer was asked to make recommendations for normal maintenance and inspection. These are given below:

a. Leaks at the flanges - Check that retaining ring splits are as close together as possible and that flat steel washers are used on the bolts over the splits. Bolts should be tightened uniformly by moving alternately around the flange from bolt to bolt. Bolts should be tightened until the rubber on the joint flange bulges slightly and uniformly between the steel retaining rings and the piping flanges.

b. Cracks at base of arch and/or flanges - This is caused by unexpected pipe movements which puts excessive stress on the joint. If cracks are severe enough to interfere with the integrity of the joint, the joint must be replaced after the cause of the damage has been corrected. Most common reasons for cracking are: initial misalignment at time of installation, excessive pipe movement, improper anchorage, neglecting to use control rods.

c. Ballooned or otherwise deformed arches - This indicates interior displacement of reinforcing rings or wire. Usually because of higher than recommended pressures. Joint must be replaced after complete working conditions have been checked and proper recommendations have been made.

d. Loose outer body fabric - Feeling the arch softness or looseness near the surface will indicate a loss of adhesion between fabric plies. If plies have separated, joint must be replaced.

e. Spongy feeling of joint body - This is caused by moisture penetration and deterioration of the fabric usually the result of loose bolts and/or deterioration of or physical damage to the hole sealant. Check out operating conditions and replace joint.

f. Hardness and cracking of the cover - Caused by exposure to extreme heat, chemical fumes, ozone and other elements in the service conditions. Examine the interior of the joint and if hardness and cracking is present, the joint must be replaced after the cause of the failure has been determined and the proper joint specified.

g. Cuts and gouges in the cover - Caused by careless handling or damage from tools. If the damage is no deeper than one ply, recommend repairs with a self-vulcanizing material.

2. The Naval Ship's Technical Manual was also consulted and in Chapter 505 (old chapter 9480) section 9480.21 titled "Piping Systems", it states:

b. Rubber expansion joints in normally unmanned spaces shall be replaced at periods not to exceed six years.

c. Rubber expansion joints in manned spaces shall be replaced at periods not exceeding 10 years and shall be checked internally for cuts, gouges, etc. during each 5 year period. For small diameter joints, this will require removing the expansion joint from the system. Large diameter joints, such as those found in condenser piping can frequently be checked from inside the condenser heads.

*R. T. Hess*

R. T. HESS

Captain, U. S. Coast Guard  
Chairman

*R. C. Yazbek*

R. C. YAZBEK

Lieutenant (junior grade), U. S. Coast Guard  
Member and Recorder