

AD-A142 186

21ST STREET PUMPING STATION BETTENDORF IOWA HYDRAULIC  
MODEL INVESTIGATION(U) ARMY ENGINEER WATERWAYS  
EXPERIMENT STATION VICKSBURG MS HYDRA... R R COPELAND  
APR 84 WES/TR/HL-84-5 F/G 13/2

1/1

UNCLASSIFIED

NL

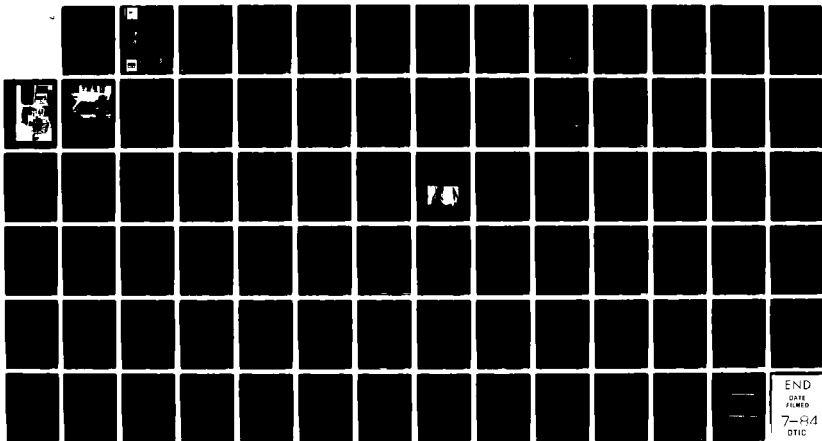

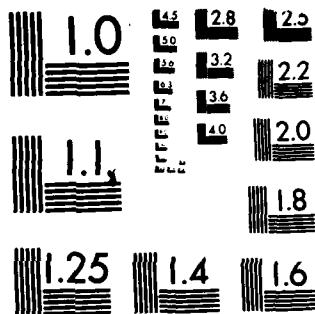

MICROCOPY RESOLUTION TEST CHART  
NATIONAL BUREAU OF STANDARDS-1963-A



US Army Corps  
of Engineers

AD-A142 186



TECHNICAL REPORT HL-84-5

12

# 21st STREET PUMPING STATION, BETTENDORF, IOWA

## HYDRAULIC MODEL INVESTIGATION

by

Ronald R. Copeland

Hydraulics Laboratory

U. S. Army Engineer Waterways Experiment Station  
P. O. Box 631, Vicksburg, Miss. 39180



April 1984

Final Report

Approved For Public Release: Distribution Unlimited

DTIC FILE COPY

DTIC  
ELECTE  
S JUN 19 1984  
A

Prepared for U. S. Army Engineer District, Rock Island  
Rock Island, Ill. 61201

84 06 18 051

Destroy this report when no longer needed. Do not  
return it to the originator.

The findings in this report are not to be construed as an  
official Department of the Army position unless so  
designated by other authorized documents.

The contents of this report are not to be used for  
advertising, publication, or promotional purposes.  
Citation of trade names does not constitute an  
official endorsement or approval of the use of such  
commercial products.

Unclassified

SECURITY CLASSIFICATION OF THIS PAGE (When Data Entered)

REPORT DOCUMENTATION PAGE		READ INSTRUCTIONS BEFORE COMPLETING FORM
1. REPORT NUMBER Technical Report HL-84-5	2. GPO accession NO. AD-A142186	3. RECIPIENT'S CATALOG NUMBER
4. TITLE (and Subtitle) 21st STREET PUMPING STATION, BETTENDORF, IOWA; Hydraulic Model Investigation	5. TYPE OF REPORT & PERIOD COVERED Final report	
7. AUTHOR(s) Ronald R. Copeland	6. PERFORMING ORG. REPORT NUMBER	
9. PERFORMING ORGANIZATION NAME AND ADDRESS U. S. Army Engineer Waterways Experiment Station Hydraulics Laboratory P. O. Box 631, Vicksburg, Miss. 39180	8. CONTRACT OR GRANT NUMBER(s)	
11. CONTROLLING OFFICE NAME AND ADDRESS U. S. Army Engineer District, Rock Island Clock Tower Building Rock Island, Ill. 61201	10. PROGRAM ELEMENT, PROJECT, TASK AREA & WORK UNIT NUMBERS	
14. MONITORING AGENCY NAME & ADDRESS (if different from Controlling Office)	12. REPORT DATE April 1984	13. NUMBER OF PAGES 77
	15. SECURITY CLASS. (of this report) Unclassified	
	15a. DECLASSIFICATION/DOWNGRADING SCHEDULE	
16. DISTRIBUTION STATEMENT (of this Report)  Approved for public release; distribution unlimited.		
17. DISTRIBUTION STATEMENT (of the abstract entered in Block 20, if different from Report)		
18. SUPPLEMENTARY NOTES  Available from National Technical Information Service, 5285 Port Royal Road, Springfield, Va. 22161		
19. KEY WORDS (Continue on reverse side if necessary and identify by block number) Pumping stations--Iowa. (LC) Hydraulic models. (LC) Hydraulic machinery. (LC) Pumping machinery--Models. (LC)		
20. ABSTRACT (Continue on reverse side if necessary and identify by block number)  A hydraulic model was used to evaluate the hydraulic performance of the 21st Street Pumping Station Sump for the Bettendorf, Iowa, Local Flood Protec- tion Plan. The proposed pumping station consisted of five individual pump bays oriented perpendicular to a box culvert that will provide inflow from two di- rections. The performance of the original design was characterized by surface and submerged vortices. Surface vortices were eliminated by lowering the sump  (Continued)		

DD FORM 1 JAN 73 1473 EDITION OF 1 NOV 65 IS OBSOLETE

Unclassified

SECURITY CLASSIFICATION OF THIS PAGE (When Data Entered)

Unclassified

SECURITY CLASSIFICATION OF THIS PAGE(When Data Entered)

20. ABSTRACT (Continued).

floor elevation which increased submergence on the pump. Submerged vortices were no longer observed when surface roughness was added to the sump floors and walls. The forebay in the original design was eliminated which provided for considerable economic savings. The design developed as a result of the model investigation operated satisfactorily at different sump water-surface elevations and with various combinations of pumps operating.

Unclassified

SECURITY CLASSIFICATION OF THIS PAGE(When Data Entered)

PREFACE

The model investigation of the 21st Street Pumping Station reported herein was authorized by the Office, Chief of Engineers (OCE), U. S. Army, in September 1981, at the request of the U. S. Army Engineer District, Rock Island (NCR).

This investigation was conducted during the period October 1981 to August 1982, in the Hydraulics Laboratory of the U. S. Army Engineer Waterways Experiment Station (WES), under the direction of Messrs. H. B. Simmons, Chief of the Hydraulics Laboratory, J. L. Grace, Jr., Chief of the Hydraulic Structures Division, and under the general supervision of N. R. Oswalt, Chief of the Spillways and Channels Branch. Project engineers for the model study were Messrs. R. R. Copeland and S. T. Maynard, assisted by E. L. Jefferson. Mr. B. F. Stanfield is acknowledged for his work in constructing the model. This report was prepared by Mr. Copeland.

During the course of the study, Messrs. Sam Doak, Don Logsdon, S. K. Nanda, and Rex Beach of NCR, and John S. Robertson of OCE visited WES to discuss the program of model tests, observe the model in operation, and correlate test results with concurrent design work.

Commander and Director of WES during the course of this investigation and the preparation and publication of this report was COL Tilford C. Creel, CE. Technical Director was Mr. F. R. Brown.

Section For	
DATE	
BY	
DISTRICT	
OFFICE	
PROJECT	
SUBJECT	
DISTRIBUTION	
REVISIONS	
APPROVED	
DATE	
BY	
DISTRICT	
OFFICE	
PROJECT	
SUBJECT	
DISTRIBUTION	
REVISIONS	
APPROVED	
DATE	
BY	
DISTRICT	
OFFICE	
PROJECT	
SUBJECT	
DISTRIBUTION	
REVISIONS	
APPROVED	
DATE	
BY	
DISTRICT	
OFFICE	
PROJECT	
SUBJECT	
DISTRIBUTION	
REVISIONS	
APPROVED	
DATE	
BY	
DISTRICT	
OFFICE	
PROJECT	
SUBJECT	
DISTRIBUTION	
REVISIONS	
APPROVED	
DATE	
BY	
DISTRICT	
OFFICE	
PROJECT	
SUBJECT	
DISTRIBUTION	
REVISIONS	
APPROVED	
DATE	
BY	
DISTRICT	
OFFICE	
PROJECT	
SUBJECT	
DISTRIBUTION	
REVISIONS	
APPROVED	
DATE	
BY	
DISTRICT	
OFFICE	
PROJECT	
SUBJECT	
DISTRIBUTION	
REVISIONS	
APPROVED	
DATE	
BY	
DISTRICT	
OFFICE	
PROJECT	
SUBJECT	
DISTRIBUTION	
REVISIONS	
APPROVED	
DATE	
BY	
DISTRICT	
OFFICE	
PROJECT	
SUBJECT	
DISTRIBUTION	
REVISIONS	
APPROVED	
DATE	
BY	
DISTRICT	
OFFICE	
PROJECT	
SUBJECT	
DISTRIBUTION	
REVISIONS	
APPROVED	
DATE	
BY	
DISTRICT	
OFFICE	
PROJECT	
SUBJECT	
DISTRIBUTION	
REVISIONS	
APPROVED	
DATE	
BY	
DISTRICT	
OFFICE	
PROJECT	
SUBJECT	
DISTRIBUTION	
REVISIONS	
APPROVED	
DATE	
BY	
DISTRICT	
OFFICE	
PROJECT	
SUBJECT	
DISTRIBUTION	
REVISIONS	
APPROVED	
DATE	
BY	
DISTRICT	
OFFICE	
PROJECT	
SUBJECT	
DISTRIBUTION	
REVISIONS	
APPROVED	
DATE	
BY	
DISTRICT	
OFFICE	
PROJECT	
SUBJECT	
DISTRIBUTION	
REVISIONS	
APPROVED	
DATE	
BY	
DISTRICT	
OFFICE	
PROJECT	
SUBJECT	
DISTRIBUTION	
REVISIONS	
APPROVED	
DATE	
BY	
DISTRICT	
OFFICE	
PROJECT	
SUBJECT	
DISTRIBUTION	
REVISIONS	
APPROVED	
DATE	
BY	
DISTRICT	
OFFICE	
PROJECT	
SUBJECT	
DISTRIBUTION	
REVISIONS	
APPROVED	
DATE	
BY	
DISTRICT	
OFFICE	
PROJECT	
SUBJECT	
DISTRIBUTION	
REVISIONS	
APPROVED	
DATE	
BY	
DISTRICT	
OFFICE	
PROJECT	
SUBJECT	
DISTRIBUTION	
REVISIONS	
APPROVED	
DATE	
BY	
DISTRICT	
OFFICE	
PROJECT	
SUBJECT	
DISTRIBUTION	
REVISIONS	
APPROVED	
DATE	
BY	
DISTRICT	
OFFICE	
PROJECT	
SUBJECT	
DISTRIBUTION	
REVISIONS	
APPROVED	
DATE	
BY	
DISTRICT	
OFFICE	
PROJECT	
SUBJECT	
DISTRIBUTION	
REVISIONS	
APPROVED	
DATE	
BY	
DISTRICT	
OFFICE	
PROJECT	
SUBJECT	
DISTRIBUTION	
REVISIONS	
APPROVED	
DATE	
BY	
DISTRICT	
OFFICE	
PROJECT	
SUBJECT	
DISTRIBUTION	
REVISIONS	
APPROVED	
DATE	
BY	
DISTRICT	
OFFICE	
PROJECT	
SUBJECT	
DISTRIBUTION	
REVISIONS	
APPROVED	
DATE	
BY	
DISTRICT	
OFFICE	
PROJECT	
SUBJECT	
DISTRIBUTION	
REVISIONS	
APPROVED	
DATE	
BY	
DISTRICT	
OFFICE	
PROJECT	
SUBJECT	
DISTRIBUTION	
REVISIONS	
APPROVED	
DATE	
BY	
DISTRICT	
OFFICE	
PROJECT	
SUBJECT	
DISTRIBUTION	
REVISIONS	
APPROVED	
DATE	
BY	
DISTRICT	
OFFICE	
PROJECT	
SUBJECT	
DISTRIBUTION	
REVISIONS	
APPROVED	
DATE	
BY	
DISTRICT	
OFFICE	
PROJECT	
SUBJECT	
DISTRIBUTION	
REVISIONS	
APPROVED	
DATE	
BY	
DISTRICT	
OFFICE	
PROJECT	
SUBJECT	
DISTRIBUTION	
REVISIONS	
APPROVED	
DATE	
BY	
DISTRICT	
OFFICE	
PROJECT	
SUBJECT	
DISTRIBUTION	
REVISIONS	
APPROVED	
DATE	
BY	
DISTRICT	
OFFICE	
PROJECT	
SUBJECT	
DISTRIBUTION	
REVISIONS	
APPROVED	
DATE	
BY	
DISTRICT	
OFFICE	
PROJECT	
SUBJECT	
DISTRIBUTION	
REVISIONS	
APPROVED	
DATE	
BY	
DISTRICT	
OFFICE	
PROJECT	
SUBJECT	
DISTRIBUTION	
REVISIONS	
APPROVED	
DATE	
BY	
DISTRICT	
OFFICE	
PROJECT	
SUBJECT	
DISTRIBUTION	
REVISIONS	
APPROVED	
DATE	
BY	
DISTRICT	
OFFICE	
PROJECT	
SUBJECT	
DISTRIBUTION	
REVISIONS	
APPROVED	
DATE	
BY	
DISTRICT	
OFFICE	
PROJECT	
SUBJECT	
DISTRIBUTION	
REVISIONS	
APPROVED	
DATE	
BY	
DISTRICT	
OFFICE	
PROJECT	
SUBJECT	
DISTRIBUTION	
REVISIONS	
APPROVED	
DATE	
BY	
DISTRICT	
OFFICE	
PROJECT	
SUBJECT	
DISTRIBUTION	
REVISIONS	
APPROVED	
DATE	
BY	
DISTRICT	
OFFICE	
PROJECT	
SUBJECT	
DISTRIBUTION	
REVISIONS	
APPROVED	
DATE	
BY	
DISTRICT	
OFFICE	
PROJECT	
SUBJECT	
DISTRIBUTION	
REVISIONS	
APPROVED	
DATE	
BY	
DISTRICT	
OFFICE	
PROJECT	
SUBJECT	
DISTRIBUTION	
REVISIONS	
APPROVED	
DATE	
BY	
DISTRICT	
OFFICE	
PROJECT	
SUBJECT	
DISTRIBUTION	
REVISIONS	
APPROVED	
DATE	
BY	
DISTRICT	
OFFICE	
PROJECT	
SUBJECT	
DISTRIBUTION	
REVISIONS	
APPROVED	
DATE	
BY	
DISTRICT	
OFFICE	
PROJECT	
SUBJECT	
DISTRIBUTION	
REVISIONS	
APPROVED	
DATE	
BY	
DISTRICT	
OFFICE	
PROJECT	
SUBJECT	
DISTRIBUTION	
REVISIONS	
APPROVED	
DATE	
BY	
DISTRICT	
OFFICE	
PROJECT	
SUBJECT	
DISTRIBUTION	
REVISIONS	
APPROVED	
DATE	
BY	
DISTRICT	
OFFICE	
PROJECT	
SUBJECT	
DISTRIBUTION	
REVISIONS	
APPROVED	
DATE	
BY	
DISTRICT	
OFFICE	
PROJECT	
SUBJECT	
DISTRIBUTION	
REVISIONS	
APPROVED	
DATE	
BY	
DISTRICT	
OFFICE	
PROJECT	
SUBJECT	
DISTRIBUTION	
REVISIONS	
APPROVED	
DATE	
BY	
DISTRICT	
OFFICE	
PROJECT	
SUBJECT	
DISTRIBUTION	
REVISIONS	
APPROVED	
DATE	
BY	
DISTRICT	
OFFICE	
PROJECT	
SUBJECT	
DISTRIBUTION	
REVISIONS	
APPROVED	
DATE	
BY	
DISTRICT	
OFFICE	
PROJECT	
SUBJECT	
DISTRIBUTION	
REVISIONS	
APPROVED	
DATE	
BY	
DISTRICT	
OFFICE	
PROJECT	
SUBJECT	
DISTRIBUTION	
REVISIONS	
APPROVED	
DATE	
BY	
DISTRICT	
OFFICE	
PROJECT	
SUBJECT	
DISTRIBUTION	
REVISIONS	
APPROVED	
DATE	
BY	
DISTRICT	
OFFICE	
PROJECT	
SUBJECT	
DISTRIBUTION	
REVISIONS	
APPROVED	
DATE	
BY	
DISTRICT	
OFFICE	
PROJECT	
SUBJECT	
DISTRIBUTION	
REVISIONS	
APPROVED	
DATE	
BY	
DISTRICT	
OFFICE	
PROJECT	
SUBJECT	
DISTRIBUTION	
REVISIONS	
APPROVED	
DATE	
BY	
DISTRICT	
OFFICE	
PROJECT	
SUBJECT	
DISTRIBUTION	
REVISIONS	
APPROVED	
DATE	
BY	
DISTRICT	
OFFICE	
PROJECT	
SUBJECT	
DISTRIBUTION	
REVISIONS	
APPROVED	
DATE	
BY	
DISTRICT	
OFFICE	
PROJECT	
SUBJECT	
DISTRIBUTION	
REVISIONS	
APPROVED	
DATE	
BY	
DISTRICT	
OFFICE	
PROJECT	
SUBJECT	
DISTRIBUTION	
REVISIONS	
APPROVED	
DATE	
BY	
DISTRICT	
OFFICE	
PROJECT	
SUBJECT	
DISTRIBUTION	
REVISIONS	
APPROVED	
DATE	
BY	
DISTRICT	
OFFICE	
PROJECT	
SUBJECT	
DISTRIBUTION	
REVISIONS	
APPROVED	
DATE	
BY	
DISTRICT	
OFFICE	
PROJECT	
SUBJECT	
DISTRIBUTION	
REVISIONS	
APPROVED	
DATE	
BY	
DISTRICT	
OFFICE	
PROJECT	
SUBJECT	
DISTRIBUTION	
REVISIONS	
APPROVED	
DATE	
BY	
DISTRICT	
OFFICE	
PROJECT	
SUBJECT	
DISTRIBUTION	
REVISIONS	
APPROVED	
DATE	
BY	
DISTRICT	
OFFICE	
PROJECT	
SUBJECT	
DISTRIBUTION	
REVISIONS	
APPROVED	
DATE	
BY	
DISTRICT	
OFFICE	
PROJECT	
SUBJECT	
DISTRIBUTION	
REVISIONS	
APPROVED	
DATE	
BY	
DISTRICT	
OFFICE	
PROJECT	
SUBJECT	
DISTRIBUTION	
REVISIONS	
APPROVED	
DATE	
BY	
DISTRICT	
OFFICE	
PROJECT	
SUBJECT	
DISTRIBUTION	
REVISIONS	
APPROVED	
DATE	
BY	
DISTRICT	
OFFICE	
PROJECT	
SUBJECT	
DISTRIBUTION	
REVISIONS	
APPROVED	
DATE	
BY	
DISTRICT	
OFFICE	
PROJECT	
SUBJECT	
DISTRIBUTION	
REVISIONS	
APPROVED	
DATE	
BY	
DISTRICT	
OFFICE	
PROJECT	
SUBJECT	
DISTRIBUTION	
REVISIONS	
APPROVED	
DATE	
BY	
DISTRICT	
OFFICE	
PROJECT	
SUBJECT	
DISTRIBUTION	
REVISIONS	
APPROVED	
DATE	
BY	
DISTRICT	
OFFICE	
PROJECT	
SUBJECT	
DISTRIBUTION	
REVISIONS	
APPROVED	
DATE	
BY	
DISTRICT	
OFFICE	
PROJECT	
SUBJECT	
DISTRIBUTION	
REVISIONS	
APPROVED	
DATE	
BY	
DISTRICT	
OFFICE	
PROJECT	
SUBJECT	
DISTRIBUTION	
REVISIONS	
APPROVED	
DATE	
BY	
DISTRICT	
OFFICE	
PROJECT	
SUBJECT	
DISTRIBUTION	
REVISIONS	
APPROVED	
DATE	
BY	
DISTRICT	
OFFICE	
PROJECT	
SUBJECT	
DISTRIBUTION	
REVISIONS	
APPROVED	
DATE	
BY	
DISTRICT	
OFFICE	
PROJECT	
SUBJECT	
DISTRIBUTION	
REVISIONS	
APPROVED	
DATE	
BY	
DISTRICT	
OFFICE	
PROJECT	
SUBJECT	
DISTRIBUTION	
REVISIONS	
APPROVED	
DATE	
BY	
DISTRICT	
OFFICE	
PROJECT	
SUBJECT	
DISTRIBUTION	
REVISIONS	
APPROVED	
DATE	
BY	
DISTRICT	
OFFICE	
PROJECT	
SUBJECT	
DISTRIBUTION	
REVISIONS	
APPROVED	
DATE	
BY	
DISTRICT	
OFFICE	
PROJECT	
SUBJECT	
DISTRIBUTION	
REVISIONS	
APPROVED	
DATE	
BY	
DISTRICT	
OFFICE	
PROJECT	
SUBJECT	
DISTRIBUTION	
REVISIONS	
APPROVED	
DATE	
BY	
DISTRICT	
OFFICE	
PROJECT	
SUBJECT	
DISTRIBUTION	
REVISIONS	
APPROVED	
DATE	
BY	
DISTRICT	
OFFICE	
PROJECT	
SUBJECT	
DISTRIBUTION	
REVISIONS	
APPROVED	
DATE	
BY	
DISTRICT	
OFFICE	
PROJECT	
SUBJECT	
DISTRIBUTION	
REVISIONS	
APPROVED	
DATE	
BY	
DISTRICT	
OFFICE	
PROJECT	
SUBJECT	
DISTRIBUTION	
REVISIONS	
APPROVED	
DATE	
BY	
DISTRICT	
OFFICE	
PROJECT	
SUBJECT	
DISTRIBUTION	
REVISIONS	
APPROVED</	

CONTENTS

	<u>Page</u>
PREFACE . . . . .	1
CONVERSION FACTORS, U. S. CUSTOMARY TO METRIC (SI) UNITS OF MEASUREMENT . . . . .	3
PART I: INTRODUCTION . . . . .	5
The Prototype . . . . .	5
Purpose of the Model Study . . . . .	6
PART II: THE MODEL . . . . .	8
Description . . . . .	8
Interpretation of Model Results . . . . .	8
PART III: TEST RESULTS . . . . .	15
Method of Operation . . . . .	15
Original Sump Design . . . . .	15
Modifications to Type 1 Design Sump . . . . .	17
Type 2 Design Sump . . . . .	26
Type 3 Design Sump . . . . .	31
PART IV: CONCLUSIONS . . . . .	35
REFERENCES . . . . .	37
TABLES 1-31	
PLATES 1-6	

CONVERSION FACTORS, U. S. CUSTOMARY TO METRIC (SI)  
UNITS OF MEASUREMENT

U. S. customary units of measurement used in this report can be converted to metric (SI) units as follows:

<u>Multiply</u>	<u>By</u>	<u>To Obtain</u>
acres	0.4047	hectares
cubic feet per second	0.02831685	cubic metres per second
Fahrenheit degrees	*	Celsius or Kelvins
feet	0.3048	metres
feet of water	0.03048	kilograms per square centimetre
feet per second	0.3048	metres per second
gallons per minute	3.785412	cubic decimetres per minute
inches	25.4	millimetres
miles (U. S. statute)	1.609344	kilometres

---

\* To obtain Celsius (C) temperature readings from Fahrenheit (F) readings, use the following formula:  $C = (5/9)(F - 32)$ . To obtain Kelvin (K) readings, use:  $K = (5/9)(F - 32) + 273.15$ .

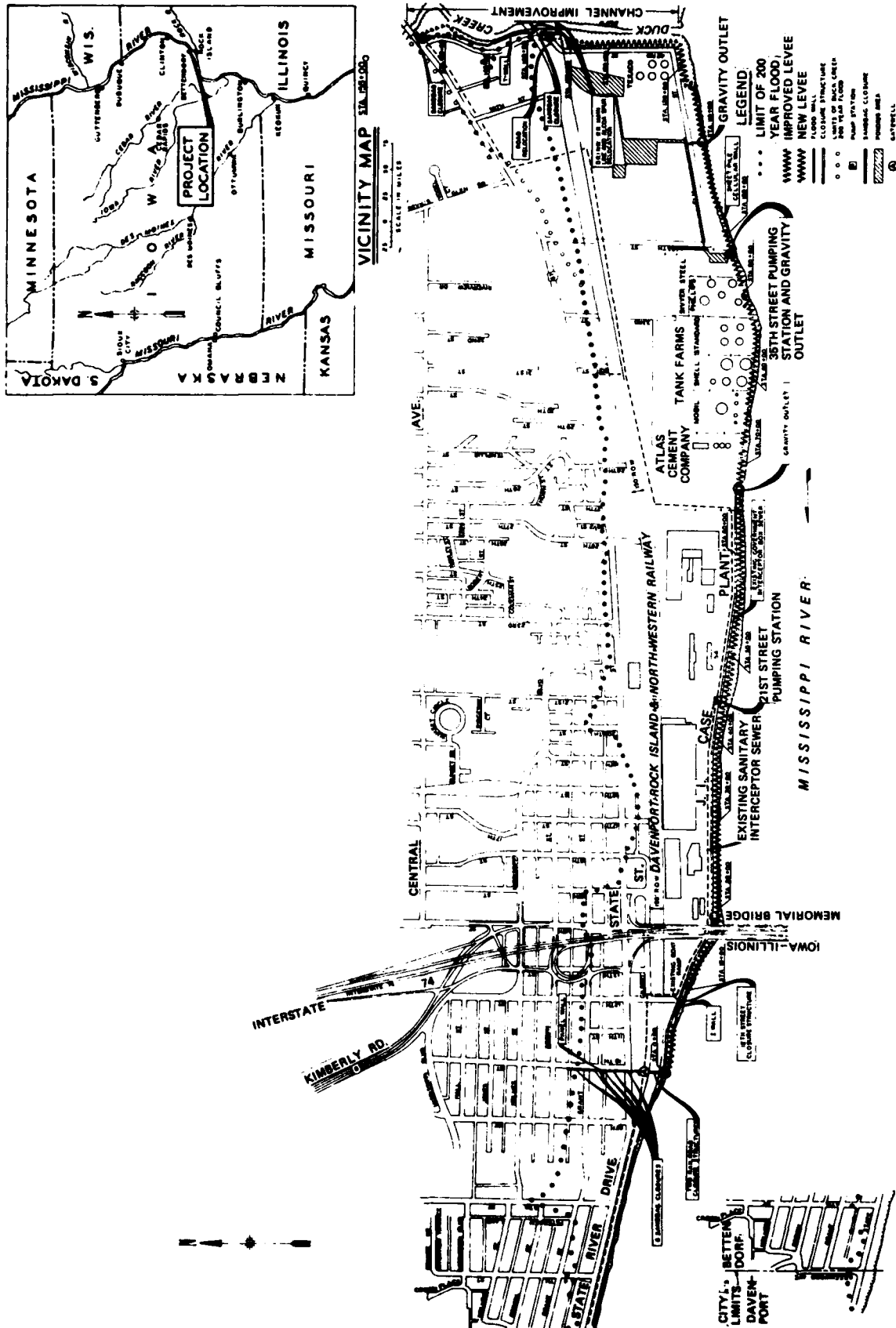

Figure 1. Location map

21st STREET PUMPING STATION, BETTENDORF, IOWA

Hydraulic Model Investigation

PART I: INTRODUCTION

The Prototype

1. The city of Bettendorf, Iowa, is located on the Mississippi River approximately 3 miles\* upstream from Lock and Dam 15. The city of Davenport, Iowa, borders Bettendorf on the west (downstream) and the cities of Rock Island and Moline are located across the river in Illinois. These cities are regionally known as the Quad Cities and are important industrial and commercial centers for a large and prosperous agricultural area. Bettendorf's location is shown on the vicinity map in Figure 1.

2. Bettendorf is protected from floods on the Mississippi River by levees, but the city is subject to flooding from local interior runoff that collects behind the river levee. The flood problem area consists of about 330 acres of extensively developed industrial, commercial, and residential property traversed by an important railroad and highway. The city's main business district is located in the floodplain. Due to relatively high water levels in Pool 15, which is adjacent to the city, gravity drainage into the Mississippi River is usually impractical. Currently, local drainage in the cities of Bettendorf and Davenport is diverted to the government sewer, which parallels the levee and discharges into the river below Lock and Dam 15. The sewer is inadequate to handle the runoff from significant local rainfalls.

3. The local flood protection plan for Bettendorf consists of a series of earth levees, floodwalls, gated closure structures, drainage structures, pumping stations, and channel improvements as shown in Figure 1. The 21st Street Pumping Station is one of two pumping stations proposed in the plan and will be located on the existing government sewer. The plan calls for closing the government sewer at the Bettendorf-Davenport city boundary when the sewer reaches capacity. This will relieve pressure on the drainage

---

\* A table of factors for converting U. S. customary units of measurements to metric (SI) units is presented on page 3.

structure through the city of Davenport by eliminating rainfall runoff from Bettendorf. The Bettendorf runoff collected in the sewer would be discharged into the Mississippi River through the 21st Street Pumping Station.

4. The 21st Street Pumping Station will have five 36-in. pumps with a combined pumping capacity of 150,000 gpm. The pumps, which will discharge directly into the Mississippi River through 36-in.-diam discharge lines equipped with flap gates, will be located in individual pump bays. Sidewalls will have a 1:4 convergence such that there will be a 0.75-in. clearance between the walls and the 60-in.-diam suction bell. The floor clearance will be 2.5 ft. The original design sump provided a minimum submergence of 2.4 ft on the suction bell. The pump bays will be located perpendicular to the government sewer, which is 7.5 ft high and 5.5 ft wide at the site. The station will draw flow from both directions of the sewer in approximately equal quantities. Operating water-surface elevations will vary between 558.5\* and 564.5. Sump dimensions and flow rates are often related to the suction bell diameter for comparison purposes. In these terms, characteristics of the original design of the 21st Street Pumping Station are:

Length (to pump center line)	3.7D
Width	1.8D
Floor clearance	0.50D
Wall clearance	0.012D
Minimum suction bell submergence	0.48D
$Q/D^{5/2}$ **	1.20

#### Purpose of the Model Study

5. Pump performance can be adversely affected by unfavorable flow conditions at the pump intake caused by low submergence of the pump impeller and by unequal flow distribution entering the sump. Air entrainment, vortex action, prerotation of flow (swirl) into the pump column, and pressure fluctuations can occur and may result in cavitation, vibration, and uneven stresses on the pump. Although, generalized studies are being conducted by the U. S.

---

\* All elevations (el) cited herein are in feet referenced to the National Geodetic Vertical Datum (NGVD).

\*\* Flow parameter, where Q = discharge in cubic feet per second and D = suction bell diameter in feet.

Army Engineer Waterways Experiment Station (WES) as part of the Electrical and Mechanical R&D Program to improve pumping station inflow-discharge hydraulics and eliminate or reduce these adverse effects, these studies have not yet produced sufficient information to develop design criteria needed for pump sumps with conduit approaches.

6. The 21st Street Pumping Station has unique features that are not adequately covered by existing design criteria. Flow approaches the station perpendicular to the pump bays, a condition that could cause adverse circulation in the sump and poor flow distribution in the pump bays. Suction bell submergence is considerably lower than most general criteria recommend. The location of the converging sidewalls is such that the suction bell clearance is much less than that generally recommended. The model study was conducted to provide an assessment of the sump's hydraulic performance for a range of anticipated operating conditions. The investigation was also intended to develop practical modifications that would improve performance of the pumping station and/or reduce construction costs.

## PART II: THE MODEL

### Description

7. The model of the 21st Street Pumping Station was constructed to an undistorted linear scale ratio of 1:8 and of transparent plastic to allow observation of submerged flow conditions. A scale was attached to the backwall of the type 1 original design sump and to the backwall of the government sewer in subsequent design sumps to indicate water-surface elevations. The government sewer was simulated for lengths of 80 ft in both directions from the sump and was also constructed of transparent plastic. The model as originally designed is shown in Figure 2.

8. Flow through the model was recirculated by centrifugal pumps. Each pump column had its own separate pump to permit simulation of various flow rates and selective operation of the pumps. Water levels were adjusted in the model by adding or draining water. Flow from each pump was measured by paddle-wheel flowmeters and displayed electronically. The flow rates were controlled by automatic valves. Flow from each of the five pumps fed into a manifold where it could flow to either of two headbays located at upstream ends of the model. Flow to the headbays was measured by paddle-wheel flowmeters, controlled by automatic valves, and displayed electronically. Flow rates through the pumps and into the headbays were controlled and monitored at a console located adjacent to the model.

9. Various instruments and methods were used to measure the factors that affect pump sump performance. Confetti and dye were used to observe and photograph flow patterns in the sump. Velocities approaching the pump column were measured with a paddle-wheel velocity meter. Visual observations were used to determine vortex activity. Prerotation of flow (swirl) into the pump column was measured by counting revolutions of a freewheeling vortimeter with four zero-pitched blades mounted in the pump column (Figure 3). Electronic pressure transducers were placed beneath the pump suction bells to measure instantaneous pressure fluctuations (Figure 3); a time-history was recorded on strip charts.

### Interpretation of Model Results

10. The principle of dynamic similarity, which requires that ratios of

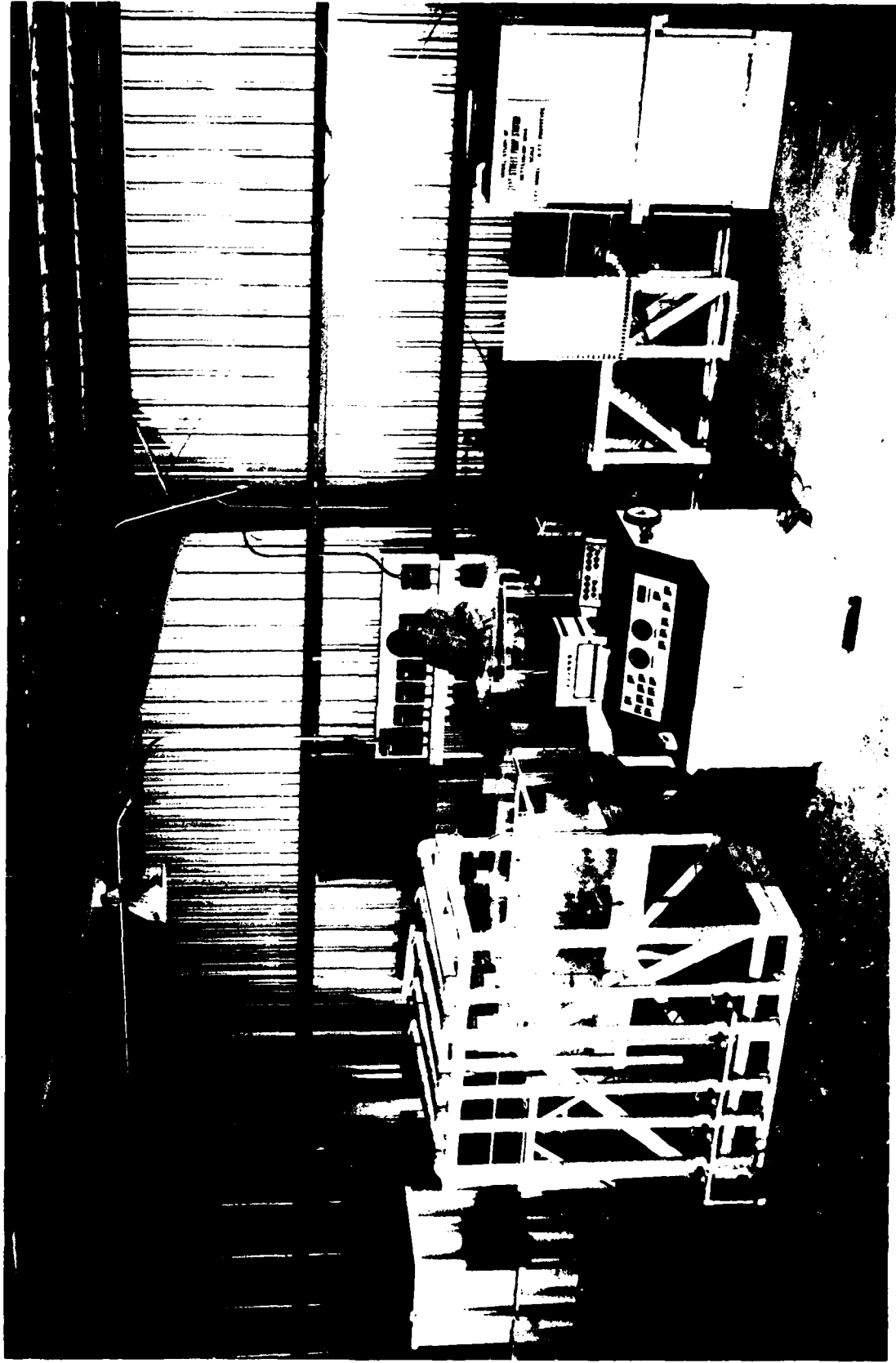

Figure 2. 1:8-scale model, type 1 design sump

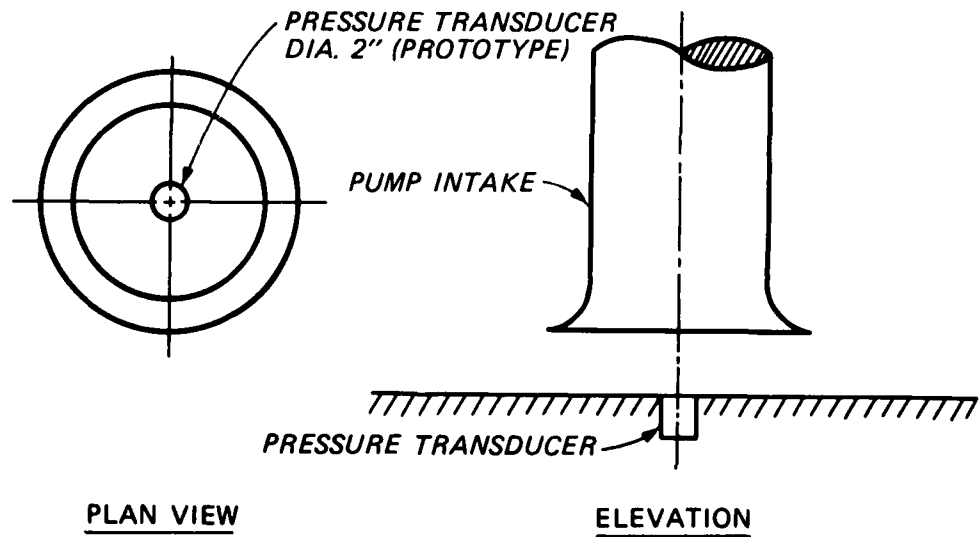
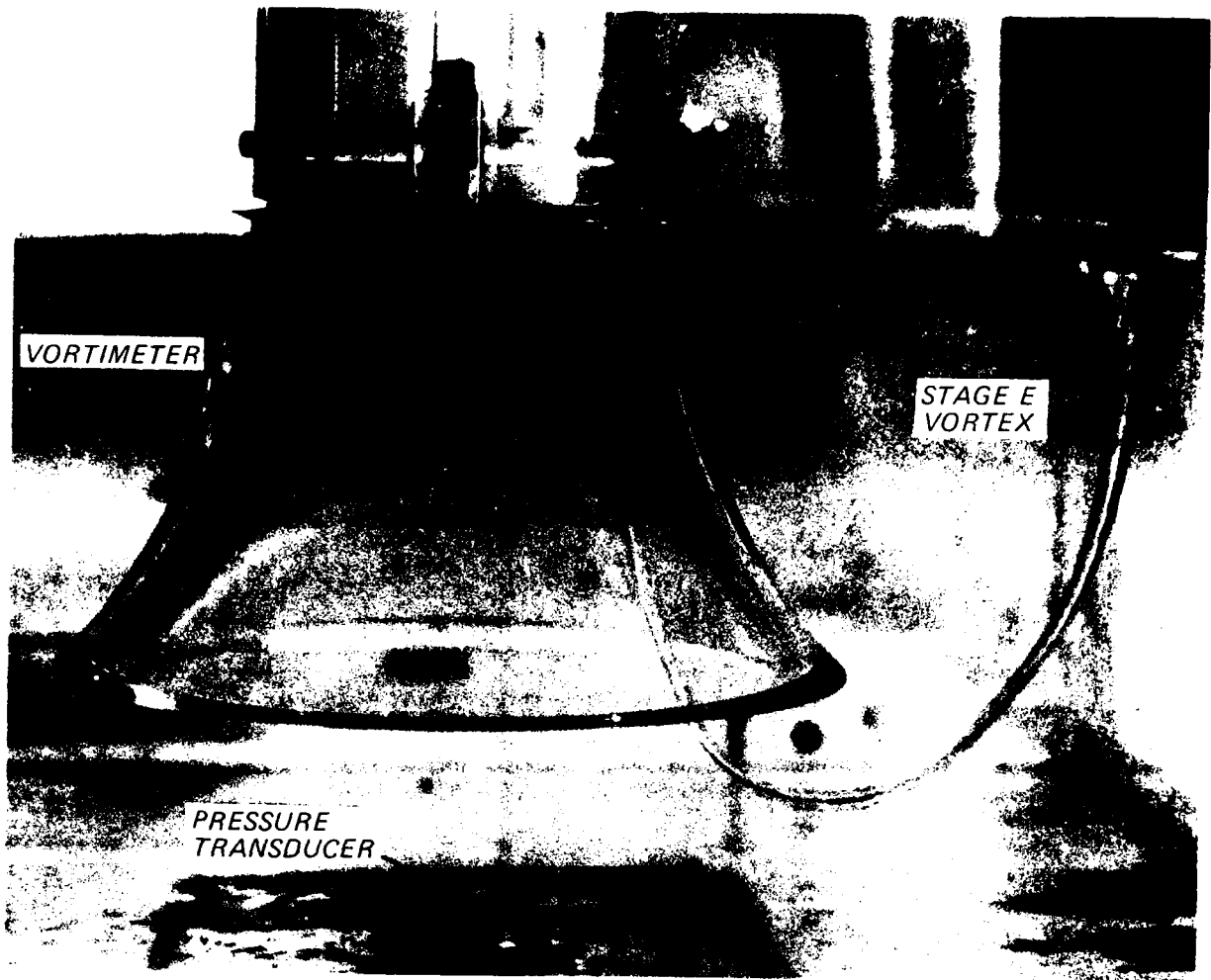

Figure 3. Flow condition monitors used in model investigation

forces be the same in model and prototype, is the basis for the design of models and the interpretation of results. Models involving a free surface are scaled to the prototype using the Froudian criteria because the flow phenomena are determined primarily by gravitational and inertial forces. The general relations expressed in terms of model scale or length ratio are as follows:

<u>Dimension</u>	<u>Ratio</u>	<u>Scale Relation</u>
Length	$L_r = L$	1:8
Velocity	$V_r = L^{1/2}$	1:2.83
Time	$T_r = L^{1/2}$	1:2.83
Discharge	$Q_r = L^{5/2}$	1:181
Pressure	$P_r = L$	1:8

Values for length, velocity, time, discharge, and pressure fluctuation can be transferred quantitatively from model to prototype by means of the scale relations above. Unless otherwise noted, all results reported herein will be given in prototype units.

11. Viscous effects can also influence flow patterns and formation of vortices. Daggett and Keulegan (1974) conducted vortex similarity tests using drain vortices in cylindrical tanks and defined a limiting Reynolds number

$$R = \frac{Q}{Av}$$

where

R = Reynolds number

Q = discharge

A = orifice radius

v = kinematic viscosity

which must be greater than  $5(10)^4$  to yield viscous effects negligible. The Reynolds number by this definition for the 21st Street model varies between  $8.4 \times 10^4$  and  $1.6 \times 10^5$  depending on temperature, thus indicating minimal viscous effects in the model. The work of Anwar and Amphlett (1980) with inverted pipe intakes shows that surface tension and viscosity effects become negligible when the radial Reynolds number

$$R_r = \frac{Q}{vh}$$

(where  $h$  equals submergence above bottom of intake pipe) is greater than  $3(10)^4$ . Using this definition for Reynolds number, it was determined the 21st Street model ( $R_r = 1.0 \times 10^4 - 1.7 \times 10^5$ ) was free of viscous and surface tension effects at water-surface elevations below 563.0 and where the temperature was greater than 65° F. Hecker (1981) reviewed available model-prototype comparisons of free surface vortices and found 16 projects where model flows were scaled by the Froudian criteria. Fourteen of these projects had model and prototype vortices essentially equal and five of the projects had vortices weaker in the model than in the prototype. Hecker concludes from the model-prototype comparisons that designs that were developed from Froude-scale model tests to be vortex-free were indeed vortex-free in the prototype, and those having weak vortices in the model had weak vortices in the prototype. No cases were found where a weak model vortex corresponded to a strong prototype vortex resulting in operating problems.

12. There are currently insufficient data to establish definite acceptable limits of uneven flow distribution, vortex activity, and pressure fluctuation; however, general guidelines have been considered and are used at WES to develop satisfactory sump designs. The flow distribution approaching the pump column should be fairly uniform because uneven distributions usually cause excessive levels of the other indicators. In this model investigation, velocities were measured at a depth halfway between the floor and the bottom of the suction bell. Every attempt is made to eliminate surface and submerged vortices. The types of vortex formations and the stages of surface vortex development observed in this study are shown and defined in Figure 4. The severity of swirl is expressed as a dimensionalized rotational flow indicator,  $R_i$ . The rotational flow indicator is the ratio of the tangential velocity at the tip of the vortimeter blade to the average axial velocity in the pump column, and is equal to the tangent of the indicated swirl angle as used by many investigators. The rotational flow indicator is computed using the following formula:

$$R_i = \frac{u}{V_a}$$

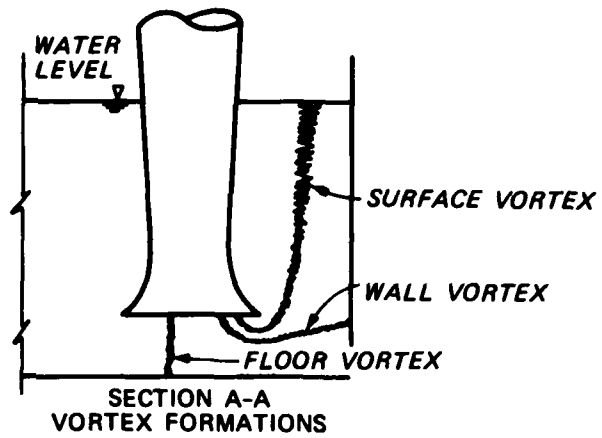

SURFACE DIMPLE WITH NO AIR ENTRAINMENT



SURFACE DEPRESSION BECOMES DEEPER

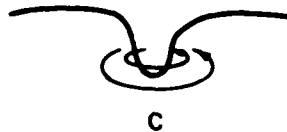

A TAIL DEVELOPS WHICH MAY HAVE A ROTATING WATER CORE BENEATH IT, DETECTABLE BY DYE

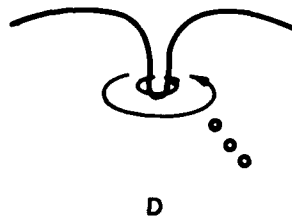

AIR ENTRAINMENT OCCURS IN THE FORM OF AIR BUBBLES DRAWN INTO THE SUCTION BELL

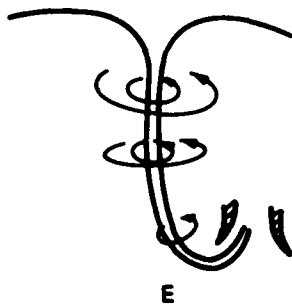

FULLY DEVELOPED VORTEX WITH OPEN AIR CORE INTO THE SUCTION BELL

STAGES OF SURFACE  
VORTEX DEVELOPMENT

Figure 4. Vortex formations

where

$$u = \pi n \ell / 60$$

$n$  = angular velocity of vortimeter, rpm

$\ell$  = length of vortimeter blade (pump column diameter), ft

$V_a$  = average axial velocity in pump column, fps

The rotational flow indicator has the same value in model and prototype and may be used to compare performance of sumps with different sizes and discharges. To ensure satisfactory sump performance, WES recommends that the rotational flow indicator be less than 0.09, which is equivalent to an indicated swirl angle of 5 deg. Maximum pressure fluctuations, measured as feet of water, represent turbulence and/or the passage of low-pressure cores across the pressure transducer located directly beneath the center line of the pump. In the model investigation, pressures were recorded for a minimum of 7 min (prototype). WES considers recorded pressure fluctuations greater than 4 ft of water as excessive. Using these guidelines, it is believed that acceptable pump sump design can be accomplished through the model investigation procedure.

### PART III: TEST RESULTS

#### Method of Operation

13. The proposed pumping station consists of five pumps designed to operate between water-surface elevations 558.5 and 564.5. The range of sump water-surface elevations at which various numbers of pumps would be operating is shown below:

<u>Number of Pumps Operating</u>	<u>Sump Water-Surface Elevation</u>	
	<u>Minimum</u>	<u>Maximum</u>
1	558.5	560.75
2	559.5	562.0
3	560.75	562.5
4	561.5	563.0
5	562.0	564.5

Due to the large number of possible combinations of pumps operating at various sump water-surface elevations, a few operating conditions were chosen to compare various modifications. These were generally pump 5 operating between el 558.5 and 561.5, and all five pumps operating between el 562.0 and 564.5. Tests were usually conducted at 1-ft intervals within this range. The original and final designs were tested with several additional operating conditions. The tests were conducted with a discharge of 67 cfs per pump. Flow entered the sump in equal quantities from both directions of the government sewer.

#### Original Sump Design

14. Flow from the government sewer entered the forebay of the type 1 (original) design sump (Figure 5) through three 10-ft wide by 5-ft-high gate openings. Flow through the center opening was deflected by the two type 1 (original) design baffles. The five pump bays were 21.08 ft long and 9 ft wide and were oriented perpendicular to the government sewer. The sidewalls converged toward the 5-ft-diam pump suction bell at an angle of 14 deg such that the clearance between the suction bell and the walls was 0.75 in. (0.012D). The backwall clearance was also 0.75 in.

15. The hydraulic performance of the type 1 design sump was found to be

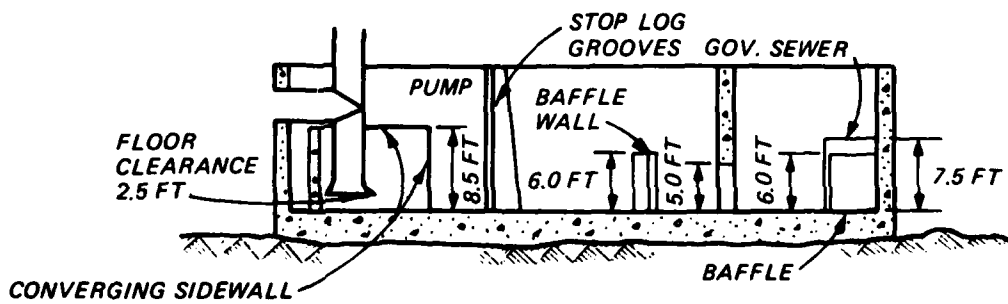
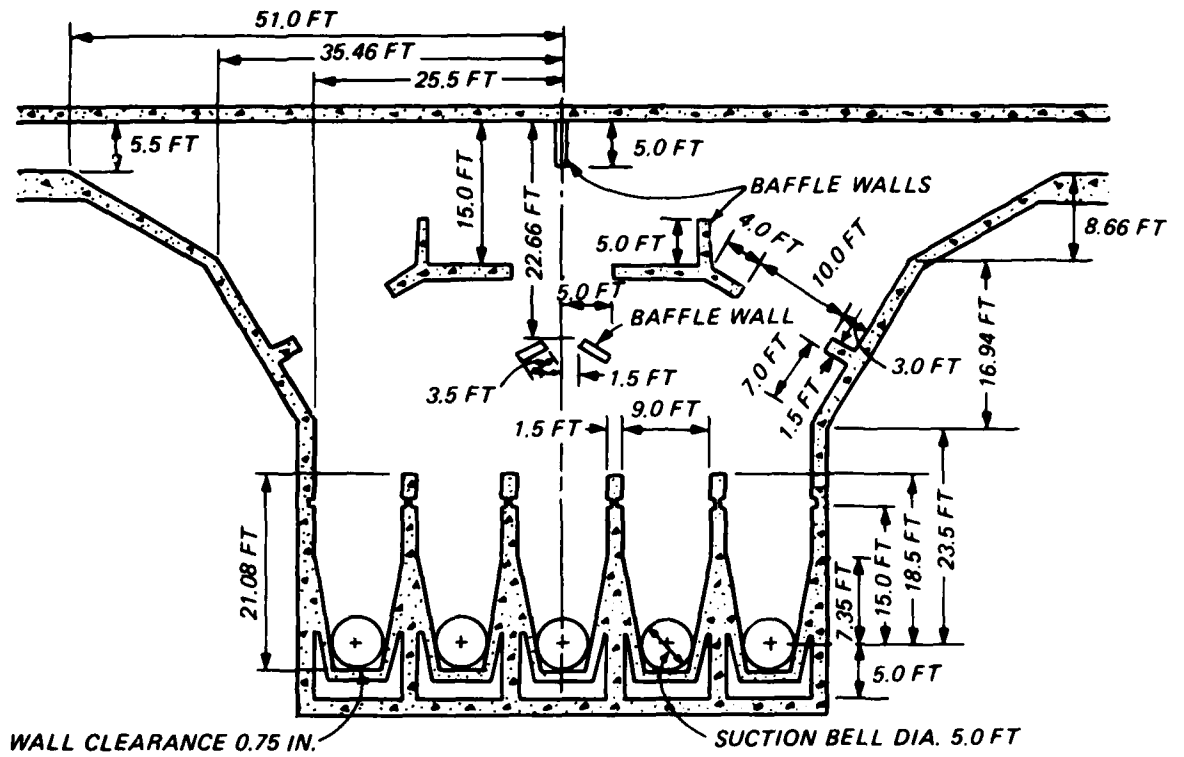

Figure 5. Type 1 design sump

unsatisfactory. Surface vortices were observed at low sump water-surface elevations. Submerged vortices were observed off the floor and sidewalls when more than one pump was operating. Eddies occurred in the pump bays because the flow did not enter uniformly. Swirl and pressure fluctuations were within acceptable limits for most of the operating conditions tested. The generally acceptable level of swirl is apparently attributed to the closeness of the converging sidewalls to the suction bell. The occurrence of submerged vortices may also be partially attributed to the sidewall's location. Test results with various combinations of pumps operating and a range of sump water-surface elevations are shown in Tables 1-4. Measured velocities and flow patterns in the pump bays for three operating conditions are shown in Plate 1.

#### Modifications to Type 1 Design Sump

16. Baffles were provided in the type 1 design sump to improve flow distribution entering the individual pump bays. The type 1 (original) design baffles were removed and the type 2 design baffles, consisting of two rows of vertical baffles, were placed in the sump as shown in Figure 6. When all five pumps were operating, flow distribution in the individual sump bays was improved and swirl was reduced, but submerged vortices continued to occur. For test conditions with one or three pumps operating, flow distributions in the

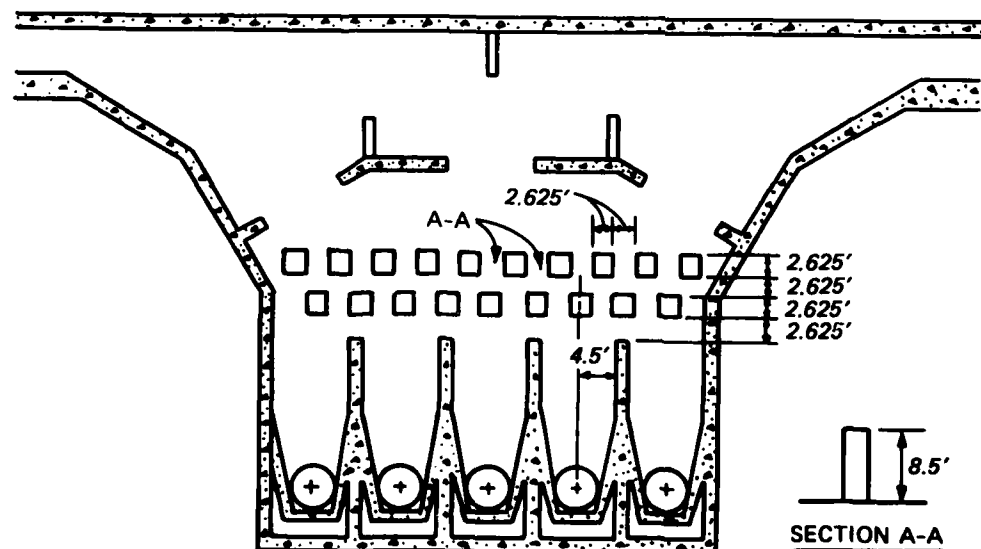

Figure 6. Type 2 design baffles

individual pump bays were not improved. Swirl increased and in some cases the severity of surface vortices increased. Submerged vortices continued to occur. Test results for one, three, and five pumps operating are shown in Table 5; measured velocities and flow patterns are shown in Plate 2.

17. Tests were conducted to determine if rounded pier noses in combination with the type 2 design baffles would improve the flow distribution and sump performance for single pump operations. Two pier noses were tested (Figure 7). The type 2 design pier nose was semicircular with a diameter equal to the sump divider wall thickness. The type 3 design pier nose had a diameter twice the sump divider wall thickness. The pier noses were tested with one pump operating in pump bay 5; results are shown in Tables 6 and 7. Swirl was slightly improved with the type 3 design pier nose, but surface and submerged vortices continued to occur. The rounded pier noses did not significantly improve hydraulic conditions in the sump.

18. An attempt was made with the type 3 design baffles to direct more flow down the center of the pump bays by moving the baffle rows closer to the pump bays and interchanging the baffles with the baffle spacings as shown in

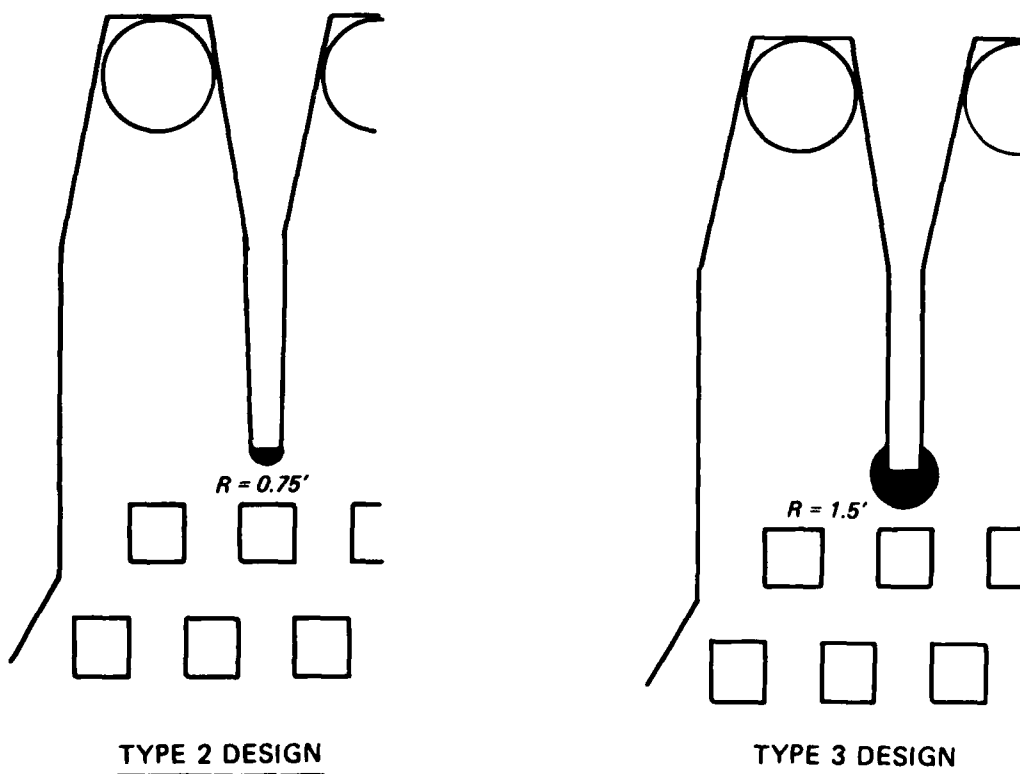

Figure 7. Type 2 and 3 design pier noses with type 2 design baffles

Figure 8. This design was tested with pump 5 operating alone and with five pumps operating; results are shown in Table 8 and Plate 3. This design provided no improvement over the type 1 (original) design sump when one pump was operating and was less effective than the type 2 design baffles when all five pumps were operating.

19. Guide vanes (or divider walls) were tested to determine if flow distribution could be improved. The type 3 design baffles were removed and the type 1 design guide vane (Figure 9) was placed in pump bay 5 and tested with one and five pumps operating. Swirl was significantly lower with the guide vane for single pump operations, but surface vortices were just as severe as without the guide vane. In addition, submerged vortices were observed with the guide vanes that were not observed with the original design. Insufficient data were taken to make reliable comparisons for five pumps operating, but the type 1 design guide vane had excessive swirl and surface and submerged vortices with the sump water surface at el 562.0. Results of these tests are presented in Table 9 and Plate 4.

20. Converging sidewalls similar to those in the 21st Street Pumping Station were concurrently tested at WES as part of the generalized pumping station research program. These tests were made in a straight approach channel, so that the flow distribution approaching the pump was uniform. The 21st Street Pumping Station's type 1 (original) design sidewalls had a minimum

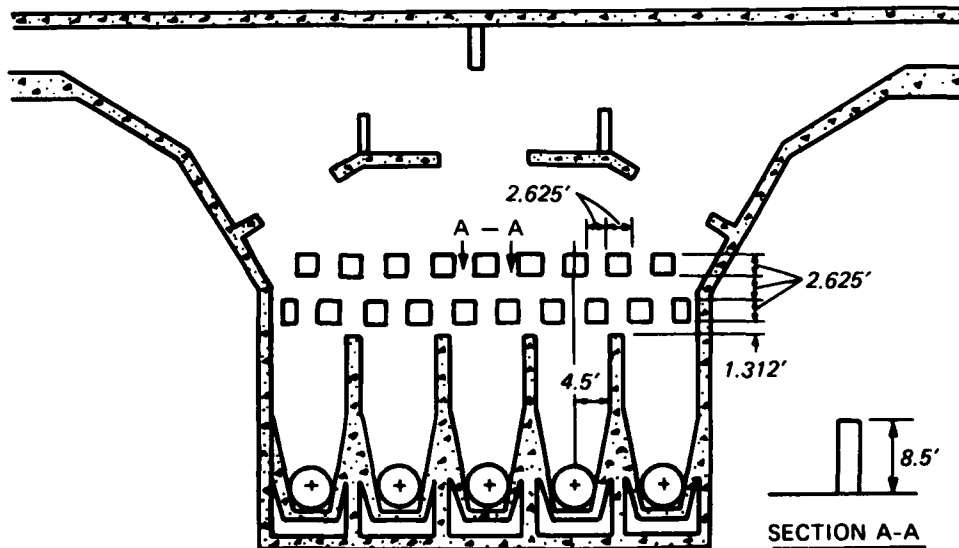

Figure 8. Type 3 design baffles

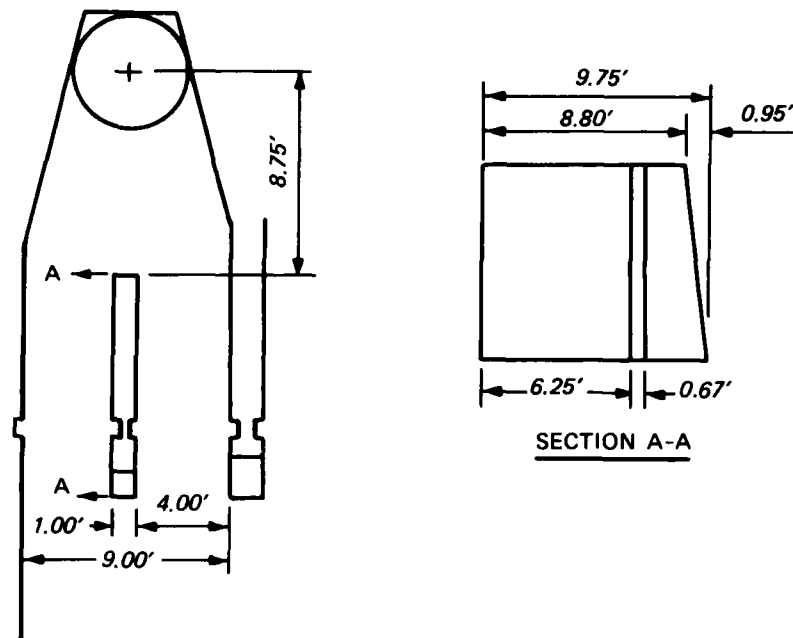

Figure 9. Type 1 design guide vane

clearance of  $0.012D$ , where  $D$  is the suction bell diameter. Sidewall clearances of  $0.05D$ ,  $0.08D$ , and  $0.17D$  were tested in the generalized model. Tests conducted at appropriately scaled flow rates and submergences in the generalized model demonstrated that submerged vortices would occur when the sidewall clearance was  $0.05D$ . When the sidewall clearance was  $0.08D$  no submerged vortices were observed at flow rates comparable to those expected at the 21st Street Pumping Station. The tests in the generalized model demonstrated that even with uniform flow distribution, submerged vortices would occur in the 21st Street Pumping Station sump with the type 1 (original) design converging sidewalls with only a clearance of  $0.012D$ . It was concluded that the sidewall clearance should be increased.

21. The sidewall clearance was increased to  $0.10D$  (0.5 ft) with the type 2 design sidewalls (Figure 10). This design was tested in pump bay 5 in combination with the type 1 design guide vane for one and five pumps operating; results are shown in Table 10. The type 2 design sidewalls were not successful in eliminating submerged vortices. This failure is attributed to the continued poor flow distribution in the pump bay. Swirl increased significantly, well beyond recommended limits, but surface vortex development was essentially the same. Pressure fluctuations also became excessive with five pumps operating. Although hydraulic performance deteriorated with the type 2 design

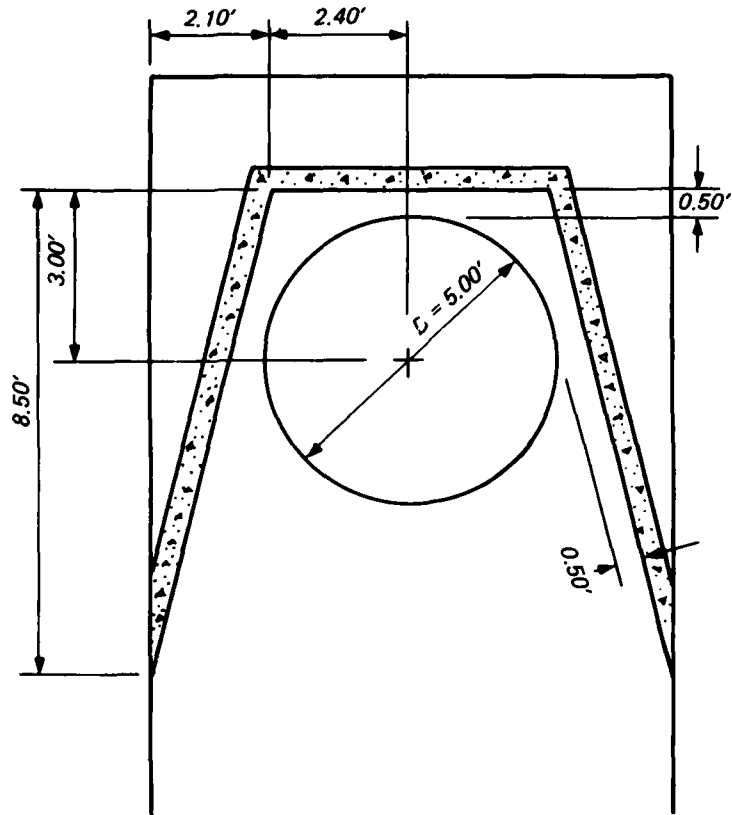

Figure 10. Type 2 design sidewalls

sidewalls, it was felt that a minimum wall clearance of  $0.10D$  would be necessary for eventual elimination of submerged vortices. The type 2 design sidewalls were therefore retained and further attempts to improve flow distribution were made.

22. The type 1 design guide vane was removed from pump bay 5 and a double guide vane (Figure 11) was installed. This type 2 design guide vane was tested in combination with the type 2 design sidewalls for one and five pumps operating (Table 11 and Plate 4). The type 2 design guide vane did not provide any significant improvement over the type 1 design guide vane. One guide wall would be easier to construct than two, so the type 1 design guide vane was put back into the model.

23. Horizontal vortex suppressor beams were added to pump bay 5 in combination with the type 1 design guide vane and the type 2 design sidewalls in an attempt to reduce surface vortices. Location and sizing of the beams (Figure 12) were based on a design from the generalized pumping station research program at WES. The type 1 design vortex beams were tested for one and

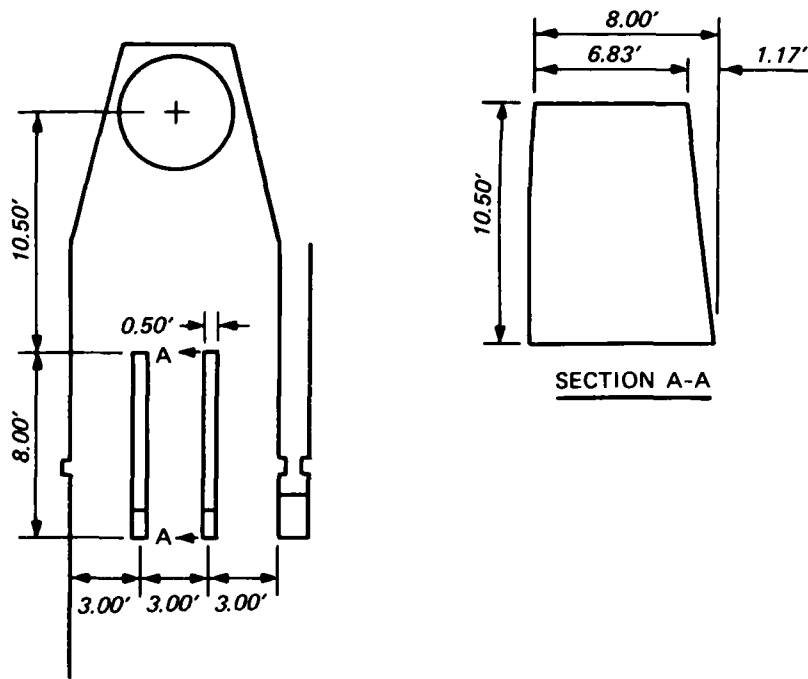

Figure 11. Type 2 design guide vane

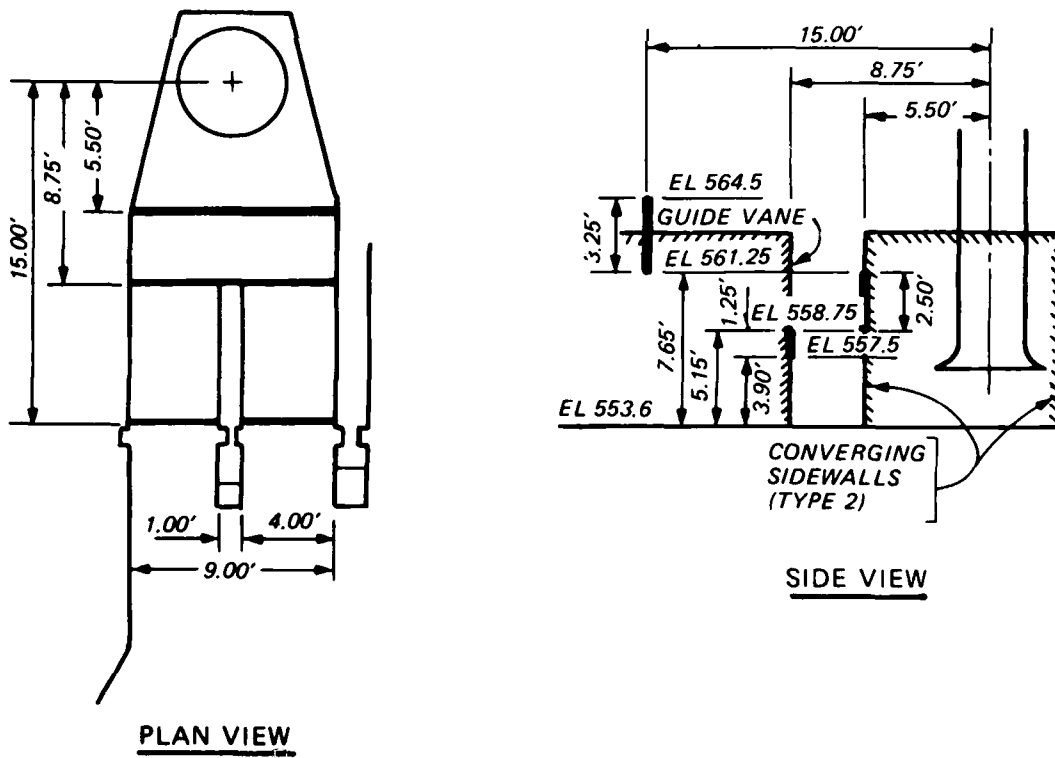

Figure 12. Type 1 design vortex suppressor beams with type 1 design guide vane and type 2 design sidewalls

five pumps operating; results are shown in Table 12. The addition of the vortex beams to the type 1 design guide vane and the type 2 design sidewalls reduced surface vortices significantly; stage C vortices were only observed at the minimum sump elevation of 558.5. Swirl was also significantly reduced, although it remained excessive for five pumps operating. Pressure fluctuations were reduced but were still excessive when five pumps were operating with a sump water surface at el 564.5. Submerged vortices continued to occur for all conditions tested.

24. The type 2 design vortex suppressor beams (Figure 13) were tested in pump bay 5 in combination with the type 1 design guide vane and the type 2 design sidewalls for one and five pumps operating. This design was based on a design developed in the Pointe Coupee Pumping Station model study conducted at WES (Copeland 1983). Results of these tests are shown in Table 13 and Plate 4. The type 2 design vortex suppressor beams eliminated surface vortices when five pumps were operating, but stage C vortices continued to occur at the minimum sump elevation of 558.5. Swirl was reduced slightly. Submerged vortices remained a problem. The type 2 design vortex beams were deemed a slight

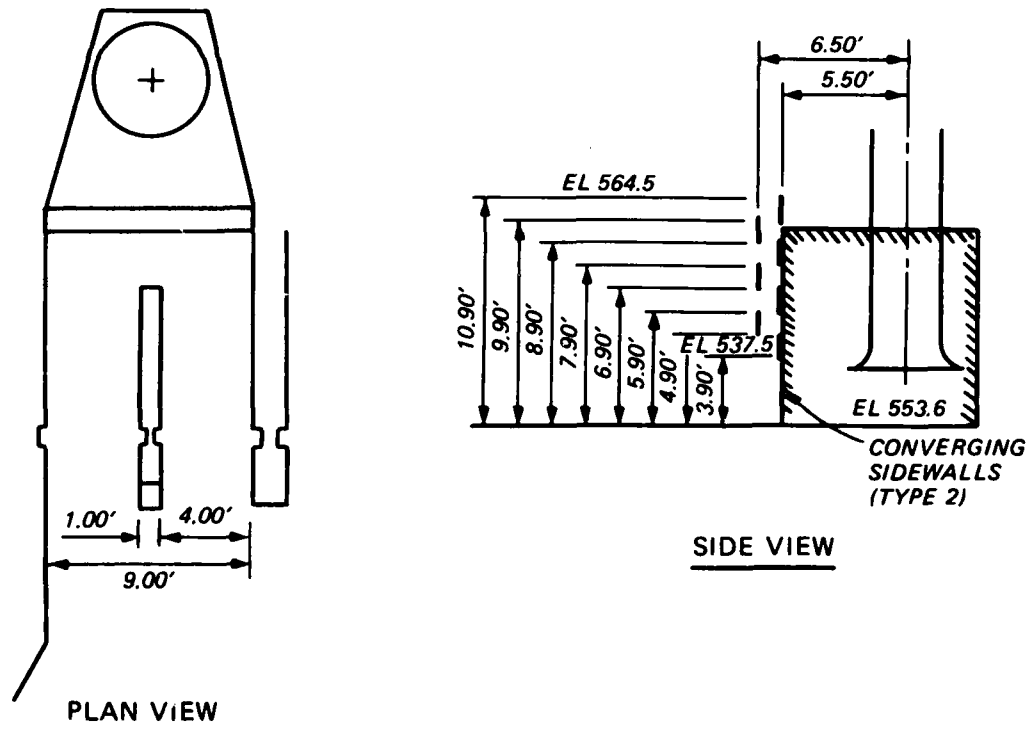

Figure 13. Type 2 design vortex suppressor beams with type 1 design guide vane and type 2 design sidewalls

improvement over the type 1 design vortex beams.

25. The effect of lengthening the pump bay by extending the divider wall was tested in pump bay 5 for one and five pumps operating (Table 14). The type 1 design wall extension (Figure 14) was tested in combination with the type 1 design guide vane, the type 2 design vortex suppressor beams, and the type 2 design sidewalls. The divider wall did not provide for any significant improvement in sump performance.

26. A sump design without converging sidewalls was developed at WES as part of the pumping station research program for sumps with uniform flow distribution approaching the pump. This design (type 51 pump bay), shown in Figure 15, was tested in pump bay 1 for single pump operations and with five pumps operating (Table 15). The type 51 design pump bay did not perform satisfactorily with the poor flow distribution that occurs in the 21st Street Pumping Station.

27. The type 4 design baffle was located in front of one of the two side gate openings (Figure 16) and was intended to deflect flow away from the side pump bay in order to improve overall flow distribution in the sump. The effect of this design on the type 51 design pump bay is shown by comparing Tables 15 and 16. When all five pumps were operating at a water-surface elevation of 562.0, the baffles were successful in significantly improving flow distribution into the side bays. However, as the water level increased to el 564.5 the baffles became less and less effective. Apparently,

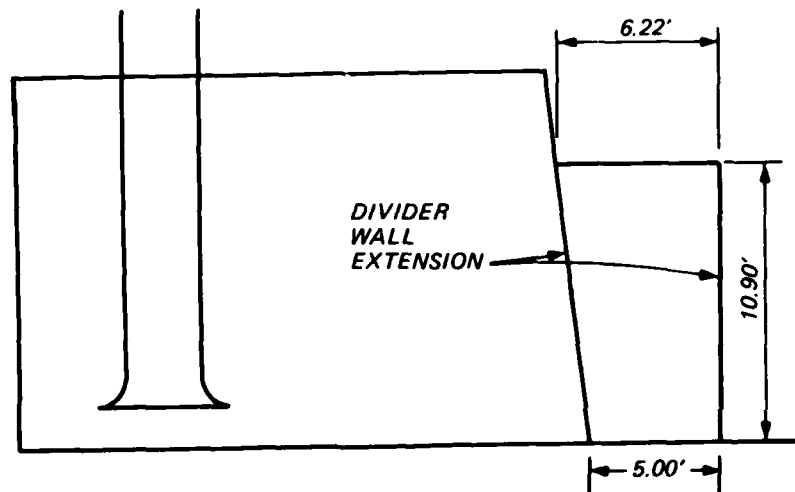

Figure 14. Type 1 divider wall extension

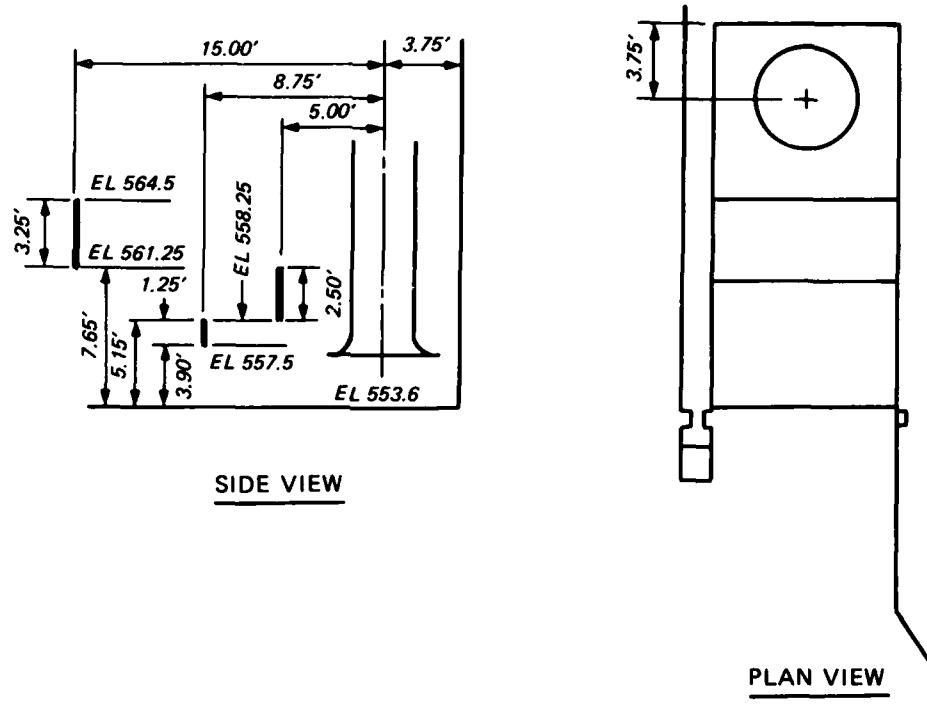

Figure 15. Type 51 design pump bay

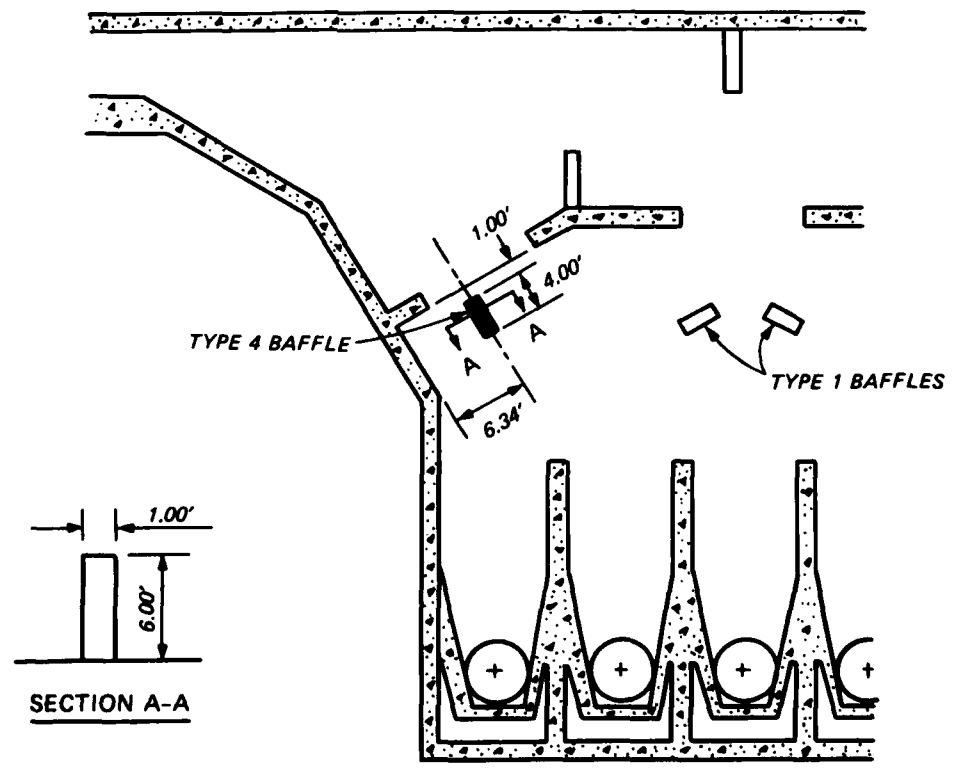

Figure 16. Type 4 design baffle

deflector-type baffles would require different configurations for each operating condition, making their use impractical.

28. The tests conducted on the type 1 (original) design sump with various modifications were unable to develop a sump design with satisfactory hydraulic performance. Features that provided for significant improvement in the sump's performance were the type 1 design guide vane and the type 2 design vortex suppressor beams. Results from the generalized pumping station research program at WES indicated that type 2 design sidewalls were also desirable. After viewing the model in operation and discussing test results of the type 1 design sump, engineers from the U. S. Army Engineer District, Rock Island, decided to discontinue attempts to improve this design so that testing could proceed on a revised sump design that would be more economical to construct.

#### Type 2 Design Sump

29. The type 2 design sump, designed by the Rock Island District, would be more economical to construct and was similar to an existing prototype pumping station at Marshalltown, Iowa, which has operated satisfactorily since construction. The type 2 design sump had no forebay so that each pump bay was connected directly to the government sewer and had individual gates (Figure 17). The type 2 design sump had the type 1 (original) design sidewalls with a suction bell clearance of  $0.012D$ . The type 1 (original) design gates were 5 ft high by 5 ft wide and were located 13.35 ft upstream from the pump center line. The total length of the individual pump bays was 22.65 ft. Results of testing this design are shown in Table 17; measured velocities and flow patterns are shown in Plate 5.

30. For single pump operations, the type 1 design sump performed slightly better than the type 2 design sump. Surface vortices occurred because of the low sump water-surface elevations. Submerged vortices occurred with the type 2 design sump but were not observed in the type 1 design sump. Swirl was within recommended limits for the type 1 design sump but exceeded acceptable values during one test with the type 2 design sump. Pressure fluctuations were within acceptable limits for both designs. The similarity in performance of the two designs for single pump operations is attributed to the relatively low velocities in the government sewer so that adverse eddies are not set up when flow enters the pump bay.

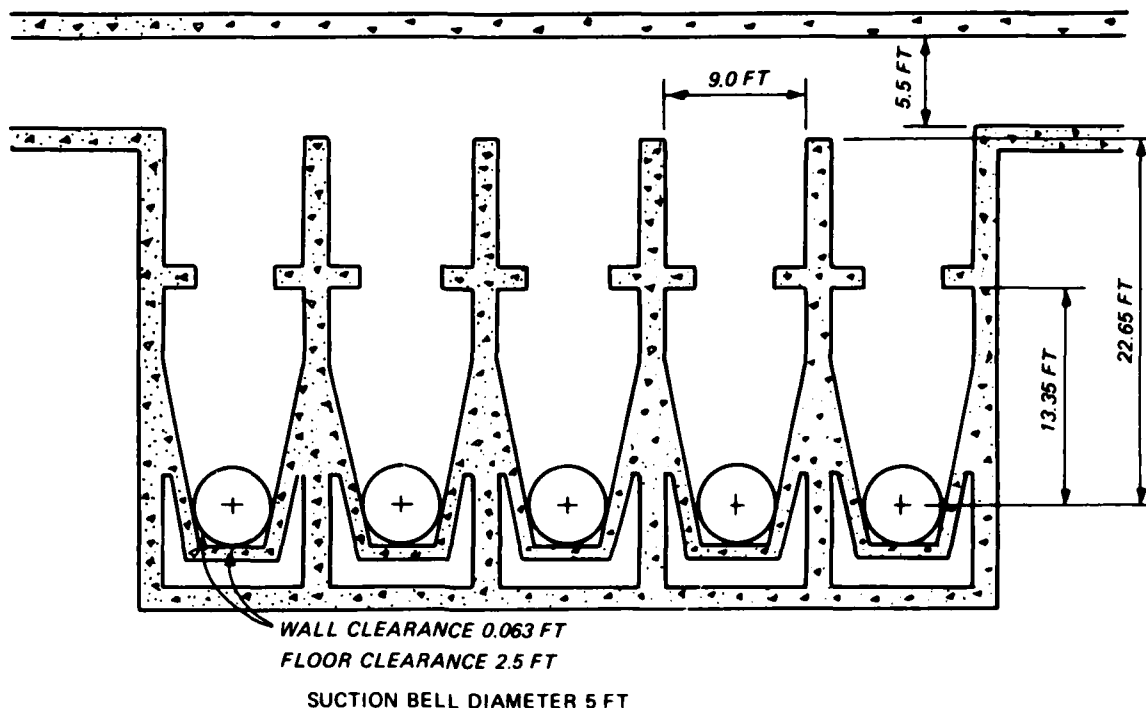

Figure 17. Type 2 design sump

31. The hydraulic performance of the type 2 design sump was much worse than the type 1 design sump for three and five pumps operating. Stage C vortices occurred in the type 2 design sump at water-surface elevations where only surface dimples had occurred in the type 1 design sump. Where swirl had been within acceptable limits with the type 1 design sump, swirl was outside these limits in every test with the type 2 design sump. With the type 2 design sump, the maximum rotational flow indicator with three pumps operating was 0.27 (three times the recommended limit); and with five pumps operating, the maximum rotational flow indicator was 0.66 (more than seven times the recommended limit). Pressure fluctuations were also much higher with the type 2 design sump exceeding recommended limits in at least one pump bay in every test. The poor performance of the type 2 design sump with multiple pump operations is attributed to the poor flow distribution entering the pump bays due to high velocities and turbulence in the government sewer.

32. Submerged sills were tested in the type 2 design sump in an attempt to straighten and equalize flow into the pump bays. Two sills were tested;

the type 1 design sill was 2.5 ft high and the type 2 design sill was 1.67 ft high. The type 1 design sill was placed in all five bays and tested for one and five pumps operating (Table 18). The type 2 design sill was placed only in pump bay 1 and tested for one and five pumps operating (Table 19). Sill location is shown in Figure 18. The type 1 design sill with five pumps operating provided for some improvement in flow distribution and swirl at high sump water-surface elevations. However, at the lower sump water-surface elevations and single pump operations, turbulence, surface vortex activity, and swirl increased. Decreasing the height of the sill to 1.67 ft (type 2 design sill) resulted in no significant difference in hydraulic performance.

33. Baffles were placed between the submerged sills and the slide gates (Figure 19) in an attempt to improve flow distribution in the pump bays. The type 5 design baffles increased turbulence and vortimeter revolutions were rapid, indicating excessive swirl in the pump column. Based on these

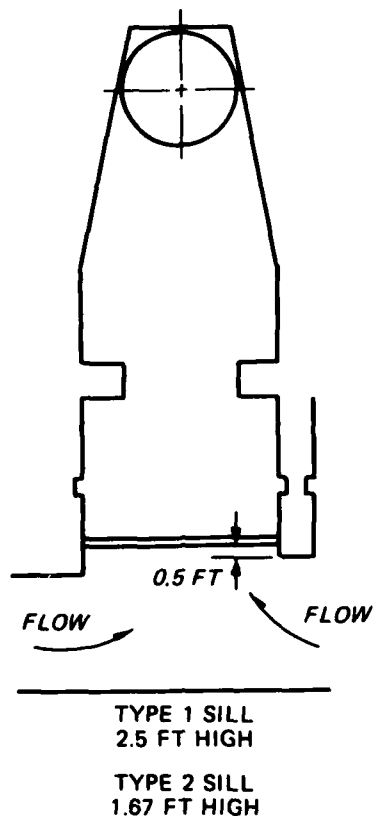

Figure 18. Type 1 and 2 design sills

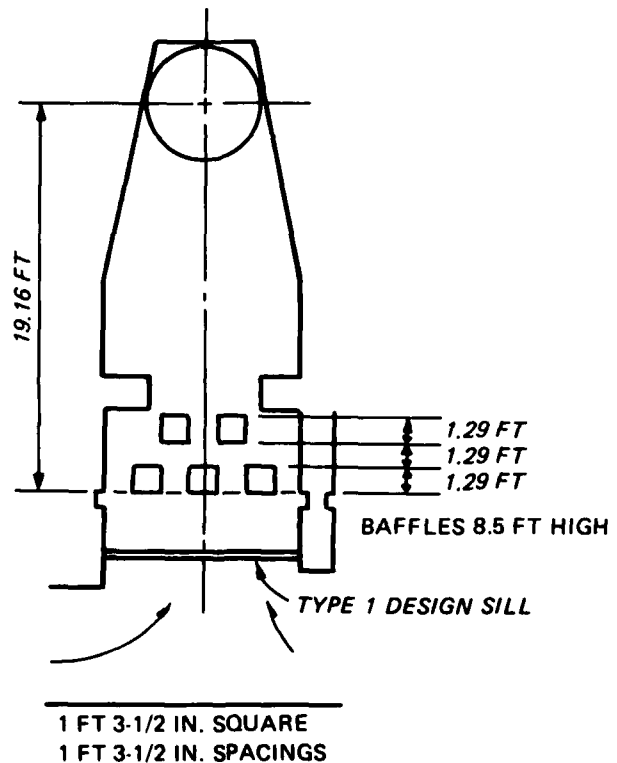

Figure 19. Type 5 design baffles

observations, this design was deemed inadequate and testing was discontinued.

34. An attempt was made to correct adverse flow patterns by placing baffles in the channel upstream from the pump bays. The type 6 design baffles (Figure 20) caused a deterioration of hydraulic performance for single-pump operations and a slight improvement with five pumps operating (Table 20).

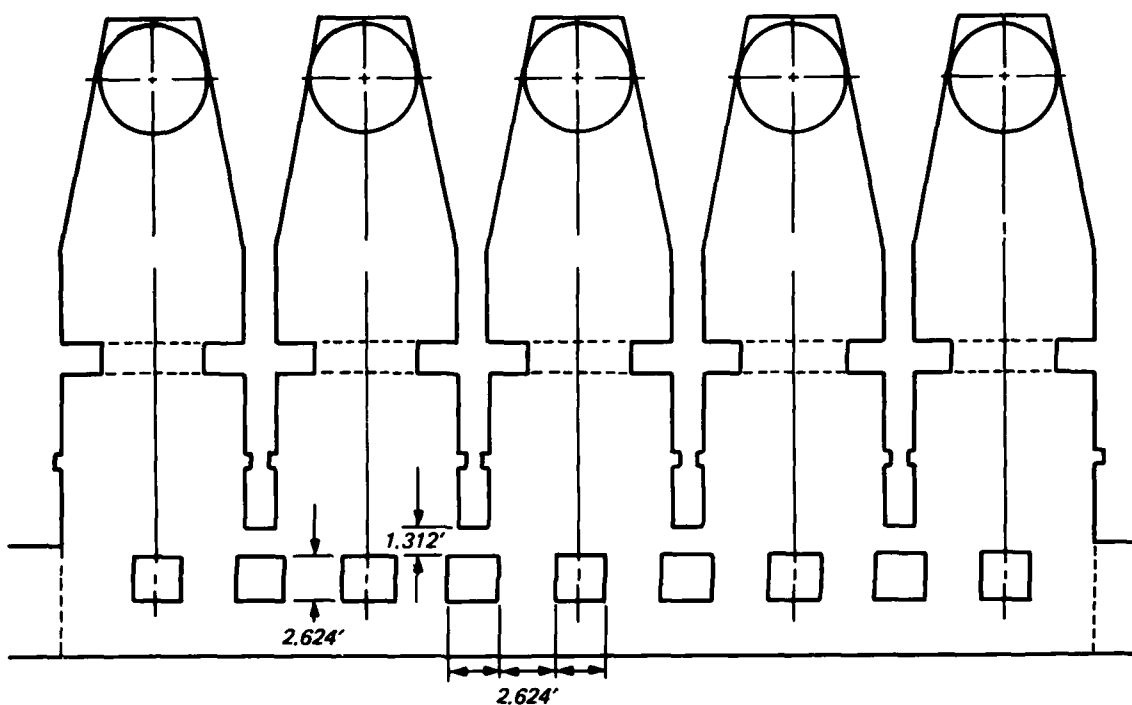

Figure 20. Type 6 design baffles

35. In order to provide a greater distance for the asymmetric flow distribution to straighten, the gates were moved to the front of the pump bays. The type 2 design gate (Figure 21) was tested for single and five pumps operating (Table 21). This design caused a slight deterioration in hydraulic performance with single pump operations, but resulted in a considerable improvement in swirl with five pumps operating. However, swirl was still above acceptable limits.

36. An attempt was made to eliminate submerged vortices by increasing the wall and floor roughness in the vicinity of the pump. The type 3 design sidewalls had vertical grooves 1 in. deep, 1 in. wide, with 1-in. separations. The vertical grooves were also placed on the backwall. Grooves with the same dimensions were placed on the sump floor perpendicular to the flow direction.

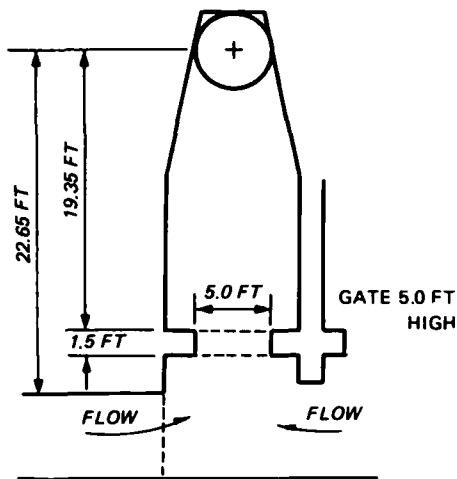

Figure 21. Type 2 design gates

The grooved floor and walls extended 6 ft upstream from the backwall (Figure 22). The type 3 design sidewalls were tested in pump bay 5 for single and five pumps operating with the type 2 design gates (Table 22). There were no observed submerged vortices; however, swirling low-pressure zones were still present and became visible when accumulated air bubbles were periodically pulled off the walls and floor. The additional boundary turbulence created by the increased surface roughness is apparently beneficial in breaking up submerged vortices.

37. Modifications to the type 2 design sump were not successful in providing anything close to satisfactory sump performance. The type 3 design sidewalls were found to be beneficial in eliminating submerged vortices and the type 2 design gate located at the front of the pump bay provided for some improvement in



Figure 22. Type 3 design sidewalls

hydraulic performance. However, surface vortices still occurred at low sump water-surface elevations and both swirl and pressure fluctuations were excessive for five pumps operating.

### Type 3 Design Sump

38. The sump floor was lowered 2 ft to el 551.6 in the type 3 design sump. The type 3 design sidewalls and the type 2 design gates were included in the type 3 design sump (Figure 23). The type 3 design sump was tested with one, three, and five pumps operating. Performance in pump bay 5 is shown in Table 23. The type 3 design sump was free from surface and submerged vortices. Increasing minimum bell submergence to 0.88D eliminated the surface vortices, and the wall and floor roughness grooves prevented submerged vortices from forming; however, swirl remained extremely high.

39. Trashracks, 8 in. deep, were added to the front of each pump bay to straighten flow and prevent trash from entering the sump. The prototype equivalents of the bars in the model were 0.40 in. wide with 3.17-in. spacings, simulating the obstructed area of a trashrack with bars 0.38 in. wide and 3.0-in. spacings (commonly used by the Rock Island District). The trashracks were effective in reducing swirl (Table 24).

40. The gates were moved from the top of the vertical drop closer to the pump. This modification made the elevation of the top of the gate opening 2 ft lower so that flow was forced closer to the pump bay floor. This helped to straighten flow and decrease swirl. Tests were conducted in pump bay 5 to optimize gate size and location. Sixteen different combinations of gate sizes and locations were tested. Surface and submerged vortices were not observed with any of the gate designs. Swirl was still excessive for many of the gate configurations as shown in Table 25. Gates 8 ft wide and either 3.75, 4.0, or 4.5 ft high (type 10-18 design gates) provided the lowest level of swirl. For these gate sizes, swirl was highest when the gate was located 3.0 ft downstream from the vertical drop, and generally decreased as the gate was moved upstream. Maximum pressure fluctuations for the type 10-18 design gates (Table 26) are generally within recommended limits, with a tendency to increase as the gate moved closer to the vertical drop. A gate location 2.25 ft downstream from the vertical drop was chosen to achieve the most favorable swirl and pressure fluctuation conditions. The 4.0- and 3.75-ft-high gates

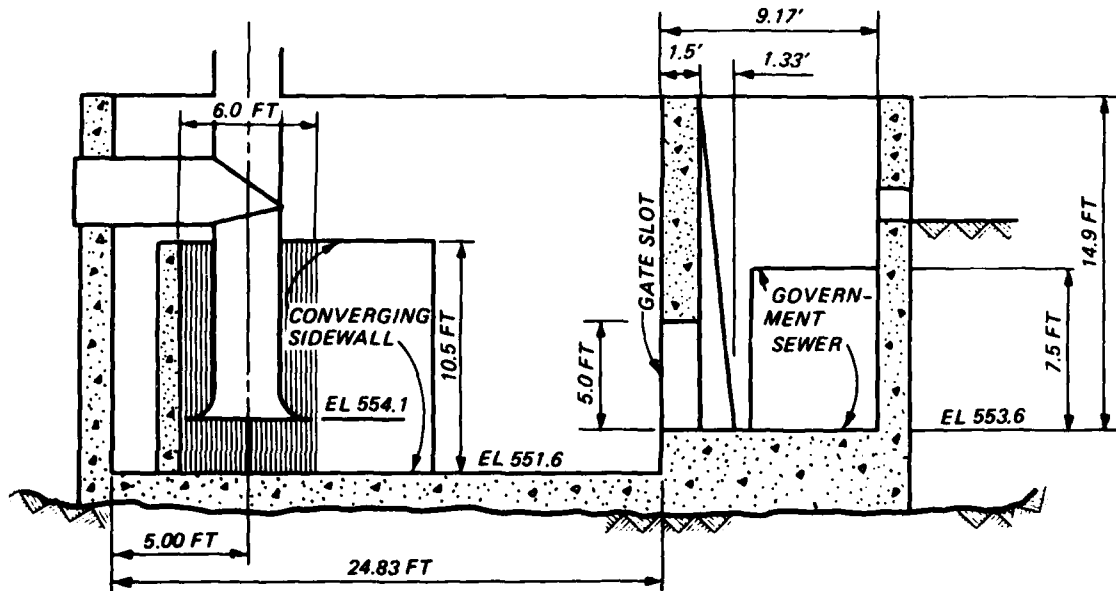
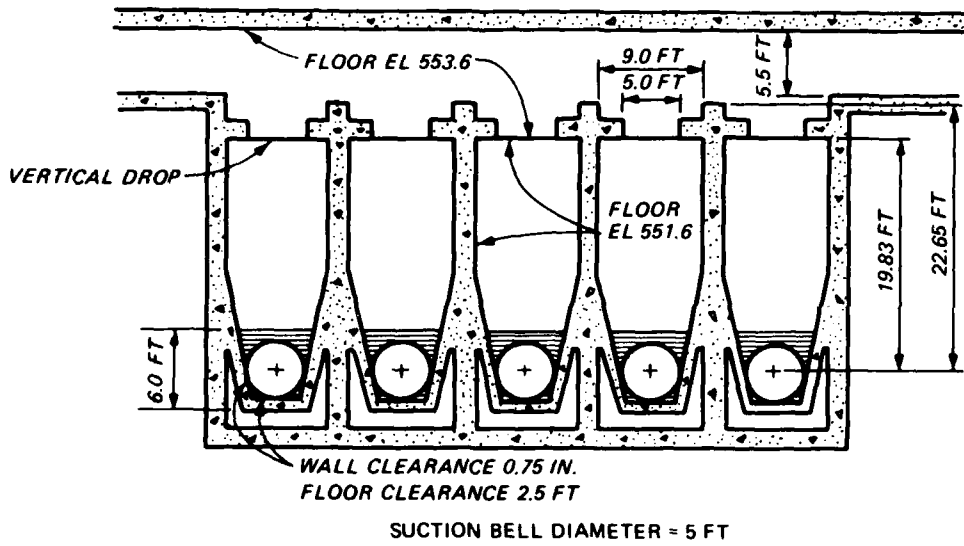

Figure 23. Type 3 design sump

(type 15 and 18 design gates, respectively) had the lowest level of swirl at this location, with the 4.5-ft-high gate (type 11 design gate) slightly higher. Recommended levels of swirl were exceeded in at least one test of each gate design. Hydraulic performance was judged to be essentially equal for the type 11, 15, and 18 design gates. For structural reasons, engineers from the Rock Island District preferred the 4.5-ft-high gate (type 11 design gate) which was thereby chosen for more extensive testing.

41. Several combinations of pumps operating and sump water-surface elevations were tested with the type 3 design sump equipped with trashracks and the type 11 design gates (Figure 24). Results of these tests are shown in Tables 27-31. Velocity measurements are shown in Plate 6. There were no surface or submerged vortices observed in any of these tests. In several tests, swirl was greater than that normally recommended by WES; that is, the rotational flow indicator was greater than 0.09 which is equivalent to having an indicated swirl angle greater than 5 deg. Maximum pressure fluctuations were within the recommended limit of 4 ft of water in all tests. The type 3 design sump with trashracks and the type 11 design gates was deemed to have adequate hydraulic performance by engineers from the Rock Island District and was the final design adopted for construction.

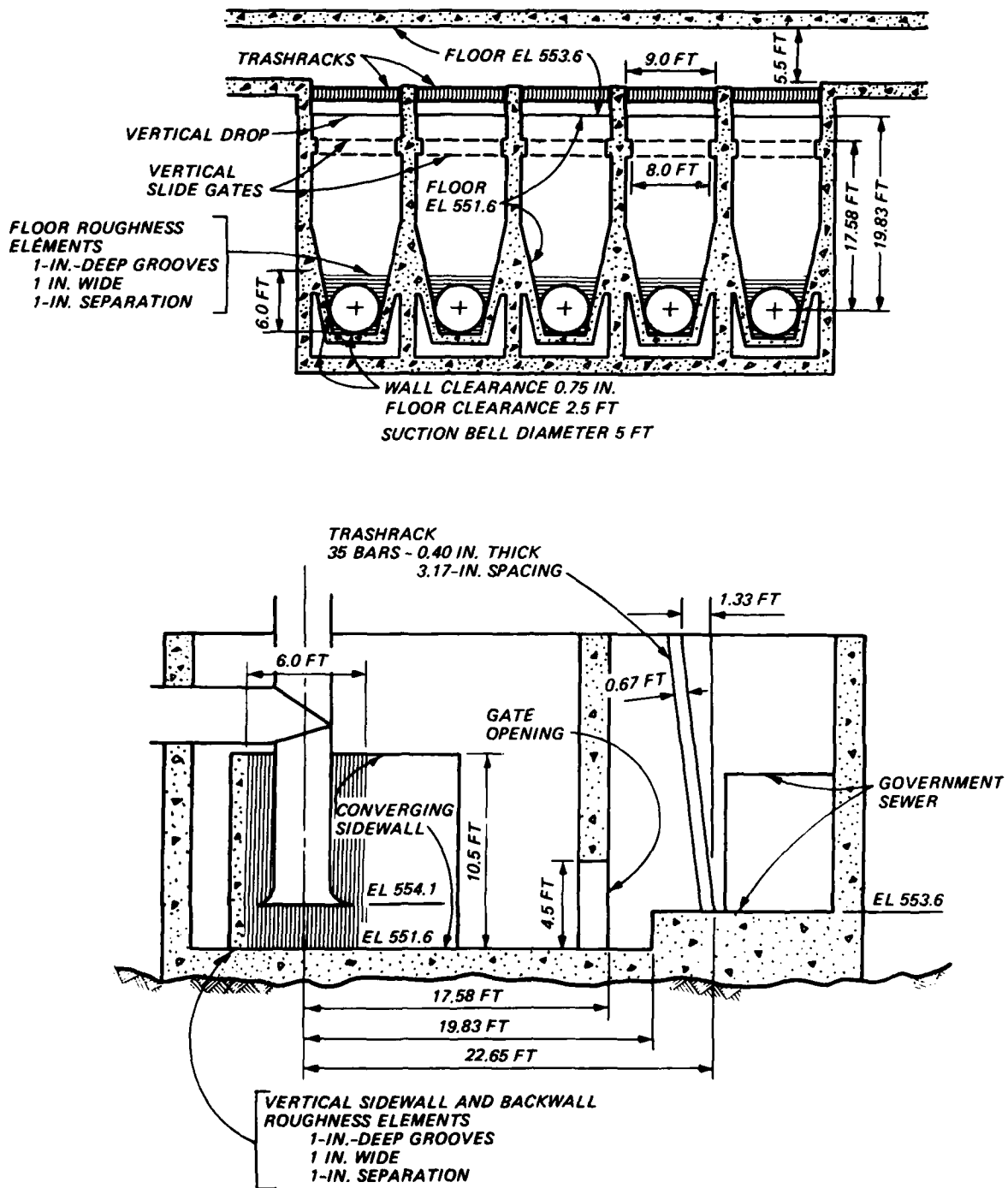

Figure 24. Type 3 design sump with trashracks and type 11 design gates

#### PART IV: CONCLUSIONS

42. Satisfactory hydraulic performance of a pump sump with flow into the pump bays perpendicular to the approach flow can be achieved with appropriate appurtenances. Converging sidewalls located such that the suction bell clearance was  $0.012D$  reduced swirl in the pump column. Trashracks with 8-in.-deep bars were effective in reducing swirl in the 9-ft-wide pump bay. Submerged vortices may be eliminated by adding roughness to the floor and walls. In this model study, vertical grooves 1 in. deep, 1 in. wide, with 1-in. separations were used on the sidewalls and backwalls; grooves with the same dimensions were located perpendicular to the flow on the floor. The additional boundary turbulence created by the increased surface roughness is apparently beneficial in breaking up submerged vortices; however, swirling low pressure zones were still present in the model and became visible when accumulated air bubbles were periodically pulled off the walls and floor. Surface vortices can be eliminated in the sump bay by providing adequate suction bell submergence. In this model study (with a flow parameter of  $Q/D^{2.5}$  equal to 1.2), a minimum suction bell submergence of  $0.88D$  eliminated surface vortices. This level of submergence was achieved by lowering the sump floor by 2 ft. Gate size and location are important in providing for the best possible hydraulic performance. Gates at or near the upstream ends of the pump bays serve to force flow toward the sump floor, helping to straighten flow and decrease swirl. A combination of these features provided for satisfactory hydraulic performance with the adopted (type 3) design sump for the 21st Street Pumping Station.

43. Other features were found to improve flow conditions in the sump but were not used in the final design. The large forebay in the type 1 design sump was more effective in distributing flow into the pump bays than were the type 2 and 3 design sumps. Swirl was much less severe with the large forebay. This feature was not included in the final design for economic reasons. Vortex suppressor beams were found to be effective in reducing swirl and surface vortices by forcing flow toward the sump floor and by creating surface turbulence which helps break up surface vortex activity. Vortex suppressors were not used in the final design because the type 11 design gate served to force the flow toward the floor, reducing swirl; and the increased submergence in the type 3 design sump was more effective in eliminating surface vortices.

Guide vanes were found to improve flow distribution in the sump, but relatively deep trashracks served the same function and were chosen for the final design. Forebays, vortex suppressor beams, and guide vanes may provide for improved hydraulic performance in future sump designs and may be useful in improving existing sumps with poor performance.

44. Several baffle configurations, rounded pier noses, increased sidewall clearance, a divider wall extension, and submerged sills were tested but they provided no significant improvement in hydraulic performance. These modifications have been shown to be successful in other pumping station sumps, but were not effective in the 21st Street Pumping Station sump where the pump bays were perpendicular to the approach flow.

## REFERENCES

- Anwar, H. O., and Amphlett, M. B. 1980. "Vortices at Vertically Inverted Intake," Journal of Hydraulic Research 18, No. 2.
- Copeland, Ronald R. 1983 (Mar). "Pointe Coupee Pumping Station Sump and Outlet Structure, Upper Pointe Coupee Loop Area, Louisiana; Hydraulic Model Investigation," Technical Report HL-83-3, U. S. Army Engineer Waterways Experiment Station, CE, Vicksburg, Miss.
- Daggett, L. L., and Keulegan, G. H. 1974 (Nov). "Similitude in Free-Surface Vortex Formations," Journal, Hydraulics Division, American Society of Civil Engineers, No. HY11.
- Hecker, G. 1981 (Oct). "Model Prototype Comparison of Free Surface Vortices," Journal, Hydraulics Division, American Society of Civil Engineers, Vol 107, No. HY10.

Table 1  
Sump Performance, Type 1 Design Sump, One Pump Operating

Sump El ft NGVD	Pumps Operating	Pump Bay No.	Surface Vortex		Submerged Vortex	Swirl-Rotational Flow Indicator	Maximum Pressure Fluctuation Feet of Water
			Stage*	Percent**			
558.5	1	1	B	50	0	+0.03	0.3
			C	17			
559.5	1	1	B	17	0	±0.03	3.6
560.75	1	1	A	56	0	±0.03	1.9
558.5	1	2	B	32	0	-0.04	--
			C	7			
559.5	1	2	A	33	0	±0.05	--
560.75	1	2	A	48	0	-0.05	--
			B	12			
558.5	1	3	A	30	0	+0.04	0.2
			B	47			
559.5	1	3	A	9	0	+0.09	0.2
			B	26			
560.75	1	3	A	13	0	+0.08	--
			B	4			
558.5	1	4	B	34	0	+0.06	0.5
			C	19			
559.5	1	4	B	14	0	+0.03	0.5
560.75	1	4	A	11	0	+0.03	0.3
			B	5			
558.5	1	5	B	37	0	+0.02	0.6
			C	16			
559.5	1	5	A	23	0	+0.05	0.6
560.75	1	5	A	31	0	+0.03	0.6

Note: + = clockwise rotation; - = counterclockwise rotation; and ± = alternating rotation.  
 Water temperature = 56°-67° F; air temperature = 57°-66° F.

\* See Figure 4, page 13, for explanation of vortex stages.

\*\* Percent duration of vortex type during period of observation.

Table 2  
Sump Performance, Type 1 Design Sump, Two Pumps Operating

Sump El ft NGVD	Pumps Operating	Pump Bay No.	Surface Vortex		Submerged Vortex	Swirl-Rotational Flow Indicator	Maximum Pressure Fluctuation Feet of Water	
			Stage*	Percent**				
559.5	2	1	A	15	IFV+IWV	+0.02	2.4	
			B	7				
	2	2	B	19	IFV+IWV	-0.10	0.2	
			C	25				
560.5	2	1	O	38	IFV+IWV	+0.02	2.0	
			A	12	IFV+IWV	-0.10		
	2	2	A	37	IFV	+0.01	1.2	
			A	40	IFV+IWV	-0.08		
562.0	2	1	O		--	+0.02	1.6	
			O		IFV	-0.09		
559.5	2	1	B	15	0	±0.02	1.6	
			5	B	23	0		±0.06
				C	3			
560.5	2	1	A	50	0	+0.03	1.2	
			5	53	0	+0.03		
561.5	2	1	A	28	0	±0.02	2.4	
			5	A	32	0		±0.03
				1	35	0		±0.02
562.0	2	5	A	40	0	+0.03	0.8	

Note: IFV = intermittent submerged vortex on floor; IWV = intermittent submerged vortex on wall; + = clockwise rotation; - = counterclockwise rotation; and ± = alternating rotation.  
 Water temperature = 55°-61° F; air temperature = 52°-59° F.

\* See Figure 4, page 13, for explanation of vortex stages.

\*\* Percent duration of vortex type during period of observation.

Table 3  
Sump Performance, Type 1 Design Sump, Three and Four Pumps Operating

Sump E1 ft NGVD	Pumps Operating	Pump Bay No.	Surface Vortex		Submerged Vortex	Swirl-Rotational Flow Indicator	Maximum Pressure Fluctuation Feet of Water
			Stage*	Percent**			
560.75	3	1	A	37	IFV-IWV	+0.02	2.8
		2	A	23	IFV-IWV	-0.07	0.2
		3	A	32	IFV-IWV	+0.03	0.8
561.5	3	1	0		IFV-IWV	±0.02	5.2
		2	0		IFV-IWV	-0.09	0.4
		3	0		IFV-IWV	-0.03	0.6
562.0	3	1	0		IFV-IWV	+0.03	1.6
		2	A	8	IFV-IWV	-0.06	0.6
		3	0		IFV-IWV	-0.03	0.6
561.5	4	1	A	40	IFV-IWV	±0.02	3.2
		2	A	35	IFV-IWV	±0.04	0.3
		3	A	30	IFV-IWV	±0.03	0.6
		4	A	50	IFV-IWV	-0.10	0.8
562.5	4	1	0		IFV-IWV	±0.04	2.0
		2	0		IFV-IWV	-0.04	0.2
		3	0		IFV-IWV	-0.03	0.8
		4	0		IFV-IWV	-0.05	0.6
563.0	4	1	0		IFV-IWV	±0.03	1.6
		2	0		IFV-IWV	-0.04	0.2
		3	0		IFV-IWV	-0.04	0.8
		4	0		IFV-IWV	-0.05	0.8

Note: IFV = intermittent submerged vortex on floor; IWV = intermittent submerged vortex on wall; + = clockwise rotation; - = counterclockwise rotation; and ± = alternating rotation.

\* Water temperature = 60°-70° F; air temperature = 54°-64° F.

\*\* See Figure 4, page 13, for explanation of vortex stages.

\*\* Percent duration of vortex type during period of observation.

Table 4  
Sump Performance, Type 1 Design Sump, Five Pumps Operating

<u>Sump El ft. NGVD</u>	<u>Pumps Operating</u>	<u>Pump Bay No.</u>	<u>Surface Vortex</u>	<u>Submerged Vortex</u>	<u>Swirl-Rotational Flow Indicator</u>	<u>Maximum Pressure Fluctuation Feet of Water</u>
563.0	5	1	0	IFV-WV	+0.04	2.0
		2	0	IFV-WV	+0.02	0.2
		3	0	IFV-WV	+0.06	5.2
		4	0	WV	±0.03	0.8
		5	0	WV	±0.02	0.6
564.0	5	1	0	WV	-0.06	2.0
		2	0	IFV	+0.04	0.2
		3	0	IFV-IWV	±0.05	1.2
		4	0	IWV	-0.03	0.6
		5	0	IWV	+0.07	0.8
564.5	5	1	0	IFV	±0.06	2.0
		2	0	IFV	±0.02	0.2
		3	0	IFV	±0.03	2.4
		4	0	IFV	±0.02	1.2
		5	0	IFV	±0.08	0.8

**Note:** WV = submerged vortex on wall; IFV = intermittent submerged vortex on floor; IWV = intermittent submerged vortex on wall; + = clockwise rotation; - = counterclockwise rotation; and ± = alternating rotation.  
 Water temperature = 62°-76° F; air temperature = 52°-60° F.

Table 5  
Sump Performance, Type 1 Design Sump, Type 2 Design Baffles

Sump El ft NGVD	Pumps Operating	Pump Bay No.	Surface Vortex Stage*	Surface Vortex Percent**	Submerged Vortex	Swirl-Rotational Flow Indicator	Maximum Pressure Fluctuation Feet of Water
558.5	1	5	B	9	0	+0.19	1.0
			C	15			
559.5	1	5	B	14	IFV-IWV	+0.09	1.0
			C	6			
560.5	1	5	0	0	0	+0.07	0.8
561.5	1	5	0	0	0	+0.04	0.8
560.5	3	3	B	33	IFV-IWV	+0.12	1.6
			B	30	IFV-IWV	+0.02	1.6
			C	35	IFV-IWV	+0.08	2.8
561.5	3	3	0	0	IFV-IWV	+0.07	0.8
			0	0	IFV-IWV	+0.01	1.2
			C	21	IFV-IWV	+0.07	1.2
562.5	3	3	0	0	0	+0.07	0.6
			0	0	0	+0.07	0.6
			0	0	0	+0.01	2.0
562.0	5	1	0	0	WV	+0.06	2.0
			0	0	FV-WV	+0.02	2.4
			0	0	FV-WV	+0.06	1.2
			0	0	FV-WV	+0.01	1.6
			C	8	WV	+0.02	4.8
564.5	5	1	0	0	0	+0.03	4.0
			0	0	0	-0.02	0.5
			0	0	0	-0.01	1.2
			0	0	0	+0.03	0.8
			0	0	0	-0.02	2.4

Note: FV = submerged vortex on floor; WV = submerged vortex on wall; IFV = intermittent submerged vortex on floor; IWV = intermittent submerged vortex on wall; + = clockwise rotation; and - = counterclockwise rotation.

\* Water temperature = 58°-87° F; air temperature = 52°-79° F.

\*\* See Figure 4, page 13, for explanation of vortex stages.

\*\* Percent duration of vortex type during period of observation.

Table 6  
Sump Performance, Type 1 Design Sump, Type 2 Design Pier Nose--Type 2 Design Baffles

<u>Sump El ft NGVD</u>	<u>Pumps Operating</u>	<u>Pump Bay No.</u>	<u>Surface Vortex Stage*</u>	<u>Percent**</u>	<u>Submerged Vortex</u>	<u>Swirl-Rotational Flow Indicator</u>	<u>Maximum Pressure Fluctuation Feet of Water</u>
558.5	1	5	B	25	IFV	+0.12	1.0
			C	15			
559.5	1	5	B	30	IFV	+0.12	1.3
			C	8			
560.5	1	5	A	27	IFV	+0.05	1.0
561.5	1	5	A	30	IFV	+0.02	2.0

Note: IFV = intermittent submerged vortex on floor; and + = clockwise rotation.  
 Water temperature = 60°-64° F; air temperature = 59°-72° F.  
 \* See Figure 4, page 13, for explanation of vortex stages.  
 \*\* Percent duration of vortex type during period of observation.

Table 7  
Sump Performance, Type 1 Design Sump, Type 3 Design Pier Nose--Type 2 Design Baffles

Sump El ft NGVD	Pumps Operating	Pump Bay No.	Surface Vortex		Submerged Vortex	Swirl-Rotational Flow Indicator	Maximum Pressure Fluctuation Feet of Water
			Stage*	Percent**			
558.5	1	5	B	23	IFV	+0.09	0.9
			C	17			
559.5	1	5	B	13	IFV	+0.03	1.0
560.5	1	5	A	10	0	+0.02	1.1
561.5	1	5	0	0	0	-0.02	1.1

Note: IFV = intermittent submerged vortex on floor; + = clockwise rotation; and - = counterclockwise rotation.  
 Water temperature = 65°-66° F; air temperature = 70°-74° F.

\* See Figure 4, page 13, for explanation of vortex stages.

\*\* Percent duration of vortex type during period of observation.

Table 8  
Sump Performance, Type 1 Design Sump, Type 3 Design Baffles

Sump El ft NGVD	Pumps Operating	Pump Bay No.	Surface Vortex		Submerged Vortex	Swirl-Rotational Flow Indicator	Maximum Pressure Fluctuation Feet of Water
			Stage*	Percent**			
558.5	1	5	C	23	IFV-IWV	+0.11	1.0
559.5	1	5	B	15	IFV-IWV	+0.11	1.6
			C	20			
560.5	1	5	A	8	0	+0.06	0.8
			B	10			
561.5	1	5	A	8	0	+0.02	1.2
562.0	5	1	B	20	IFV-IWV	±0.04	3.6
			C	17			
			A	13			
			A	20			
			C	20			
564.5	5	1	0	0	IFV-IWV	+0.08	1.6
			0	0			
			0	0			
			0	0			
			0	0			

Note: IFV = intermittent submerged vortex on floor; IWV = intermittent submerged vortex on wall; + = clockwise rotation; - = counterclockwise rotation; and ± = alternating rotation.  
Water temperature = 69°-98° F; air temperature = 75°-87° F.

\* See Figure 4, page 13, for explanation of vortex stages.

\*\* Percent duration of vortex type during period of observation.

Table 9  
Sump Performance, Type 1 Design Sump, Type 1 Design Guide Vane

Sump El ft NGVD	Pumps Operating	Pump Bay No.	Surface Vortex		Submerged Vortex	Swirl-Rotational Flow Indicator	Maximum Pressure Fluctuation Feet of Water
			Stage*	Percent**			
558.5	1	5	B	25	IWV	+0.01	0.8
			C	5			
559.5	1	5	A	38	IWV	+0.01	1.1
			B	7			
560.5	1	5	A	40	0	+0.01	3.2
			B	12			
561.5	1	5	A	37	0	+0.01	1.6
			B	17			
562.0	5	5	B	10	IFV-IWV	+0.12	1.2
			C	17			
			0	0			
564.5	5	5	0	0	0	+0.04	2.0

Note: IFV = intermittent submerged vortex on floor; IWV = intermittent submerged vortex on wall; and + = clockwise rotation.

Water temperature = 66°-83° F; air temperature = 64°-77° F.

\* See Figure 4, page 13, for explanation of vortex stages.

\*\* Percent duration of vortex type during period of observation.

Table 10

## Sump Performance, Type 1 Design Sump, Type 1 Design Guide Vane, Type 2 Design Sidewalls

Sump El ft NGVD	Pumps Operating	Pump Bay No.	Surface Vortex Stage*	Surface Vortex Percent**	Submerged Vortex	Swirl-Rotational Flow Indicator	Maximum Pressure Fluctuation Feet of Water
558.5	1	5	B C	5 11	IWV	+0.01	1.1
559.5	1	5	B C	23 17	IFV	+0.23	1.4
560.5	1	5	A B	38 20	IFV	+0.16	1.3
561.5	1	5	A	45	0	+0.15	0.8
562.0	5	5	B C	21 18	FV-IWV	+0.38	10.8
563.0	5	5	A B	13 5	IFV-IWV	+0.48	12.0
564.5	5	5	0		FV-IWV	-0.16	3.2

Note: FV = submerged vortex on floor; IFV = intermittent submerged vortex on floor; IWV = intermittent submerged vortex on wall; + = clockwise rotation; and - = counterclockwise rotation.

\* Water temperature = 70°-80° F; air temperature = 73°-76° F.

\*\* See Figure 4, page 13, for explanation of vortex stages.  
\*\* Percent duration of vortex type during period of observation.

Table 11  
Sump Performance, Type 1 Design Sump, Type 2 Design Guide Vanes, Type 2 Design Sidewalls

Sump El ft NGVD	Pumps Operating	Pump Bay No.	Surface Vortex		Submerged Vortex	Swirl-Rotational Flow Indicator	Maximum Pressure Fluctuation Feet of Water
			Stage*	Percent**			
558.5	1	5	B	38	IFV	+0.23	0.6
			C	20			
559.5	1	5	A	23	IFV	+0.14	0.8
			B	28			
560.5	1	5	A	55	IFV	+0.14	1.0
			B	20			
561.5	1	5	A	25	0	+0.19	1.0
			B	10			
562.0	5	5	B	10	IFV-IWV	+0.60	11.2
			C	11			
563.0	5	5	0	0	IFV-IWV	-0.50	8.8
			0	0			
564.5	5	5	0	0	IFV	-0.14	8.0
			0	0			

Note: IFV = intermittent submerged vortex on floor; IWV = intermittent submerged vortex on wall; + = clockwise rotation; and - = counterclockwise rotation.

Water temperature = 70°-84° F; air temperature = 65°-83° F.

\* See Figure 4, page 13, for explanation of vortex stages.

\*\* Percent duration of vortex type during period of observation.

Table 12  
Sump Performance, Type 1 Design Sump, Type 1 Design Guide Vane,  
Type 2 Design Sidewalls, Type 1 Design Vortex Beams

Sump El ft NGVD	Pumps Operating	Pump Bay No.	Surface Vortex		Submerged Vortex	Swirl-Rotational Flow Indicator	Maximum Pressure Fluctuation Feet of Water
			Stage*	Percent**			
558.5	1	5	B C	18 5	IWV	-0.02	1.2
559.5	1	5	0		IWV	-0.2	1.2
560.5	1	5	A	27	IWV	0.00	1.2
561.5	1	5	0		IWV	0.00	1.0
562.0	5	5	A B	25 11	IFV-IWV	+0.15	1.2
563.0	5	5	0		IFV-IWV	+0.17	2.0
564.5	5	5	0		IFV-IWV	+0.11	6.0

Note: IFV = intermittent submerged vortex on floor; IWV = intermittent submerged vortex on wall; + = clockwise rotation; and - = counterclockwise rotation.

Water temperature = 68°-80° F; air temperature = 69°-85° F.

\* See Figure 4, page 13, for explanation of vortex stages.

\*\* Percent duration of vortex type during period of observation.

Table 13  
Sump Performance, Type 1 Design Sump, Type 1 Design Guide Vane,  
Type 2 Design Sidewalls, Type 2 Design Vortex Suppressor Beams

<u>Sump El</u> <u>ft NGVD</u>	<u>Pumps</u> <u>Operating</u>	<u>Pump</u> <u>Bay No.</u>	<u>Surface Vortex</u> <u>Stage*</u>	<u>Percent**</u>	<u>Submerged</u> <u>Vortex</u>	<u>Swirl-Rotational</u> <u>Flow Indicator</u>	<u>Maximum Pressure</u> <u>Fluctuation</u> <u>Feet of Water</u>
558.5	1	5	B	7	IWV	+0.01	1.3
			C	13			
559.5	1	5	A	20	IWV	+0.01	1.0
			B	5			
560.5	1	5	0		IWV	0.00	1.2
561.5	1	5	0		IWV	+0.01	1.2
562.0	5	5	0		IFV-IWV	+0.07	1.2
563.0	5	5	0		IWV	+0.13	1.6

Note: IFV = intermittent submerged vortex on floor; IWV = intermittent submerged vortex on wall; and + = clockwise rotation.

Water temperature = 65°-88° F; air temperature = 69°-79° F.

\* See Figure 4, page 13, for explanation of vortex stages.

\*\* Percent duration of vortex type during period of observation.

Table 14  
Sump Performance, Type 1 Design Sump, Type 1 Design Guide Vane, Type 2 Design Sidewalls,  
Type 2 Design Vortex Suppressor Beams, Type 1 Design Wall Extension

Sump El ft NGVD	Pumps Operating	Pump Bay No.	Surface Vortex		Submerged Vortex	Swirl-Rotational Flow Indicator	Maximum Pressure Fluctuation Feet of Water
			Stage*	Percent**			
558.5	1	5	B	6	WV	+0.01	1.0
			C	4			
559.5	1	5	A	44	WV	+0.02	1.3
			C	1			
560.5	1	5	A	7	WV	+0.01	1.1
561.5	1	5	A	22	WV	+0.01	1.3
562.0	5	5	0		IFV-IWV	+0.06	1.2
563.0	5	5	0		IFV-IWV	+0.08	2.0
564.5	5	5	0		WV-IFV	±0.01	1.8

Note: WV = submerged vortex on wall; IFV = intermittent submerged vortex on floor; IWV = intermittent submerged vortex on wall; + = clockwise rotation; and ± = alternating rotation.

Water temperature = 64°-75° F; air temperature = 50°-71° F.

\* See Figure 4, page 13, for explanation of vortex stages.

\*\* Percent duration of vortex type during period of observation.

Table 15  
Sump Performance, Type 1 Design Sump, Type 51 Design Pump Bay

<u>Sump El ft NGVD</u>	<u>Pumps Operating</u>	<u>Pump Bay No.</u>	<u>Surface Vortex Stage*</u>	<u>Surface Vortex Percent**</u>	<u>Submerged Vortex</u>	<u>Swirl-Rotational Flow Indicator</u>	<u>Maximum Pressure Fluctuation Feet of Water</u>
558.5	1	1	B C	35 6	IFV	+0.08	2.8
559.5	1	1	B C	22 6	IFV	+0.12	1.2
560.5	1	1	A	8	0	+0.09	1.2
561.5	1	1	A	12	0	+0.10	1.2
562.0	5	1	A	4	IFV	-0.06	8.4
563.0	5	1	B C	7 12	IFV-IWV	-0.14	9.0
564.5	5	1	0		IFV	+0.20	9.6

Note: IFV = intermittent submerged vortex on floor; IWV = intermittent submerged vortex on wall; + = clockwise rotation; and - = counterclockwise rotation.

Water temperature = 70°-84° F; air temperature = 65°-82° F.

\* See Figure 4, page 13, for explanation of vortex stages.

\*\* Percent duration of vortex type during period of observation.

Table 16  
 Sump Performance, Type 1 Design Sump, Type 51 Design Pump Bay, Type 4 Design Baffle

Sump E1 ft NGVD	Pumps Operating	Pump Bay No.	Surface Vortex		Submerged Vortex	Swirl-Rotational Flow Indicator	Maximum Pressure Fluctuation Feet of Water
			Stage*	Percent**			
558.5	1	1	B C	35 14	IFV	+0.10	4.2
559.5	1	1	0	0	IWV	+0.07	1.1
560.5	1	1	0	0	IFV-IWV	+0.12	1.0
561.5	1	1	0	0	IWV	+0.26	0.8
562.0	5	1	A	12	0	+0.02	0.8
563.0	5	1	A B	30 15	IFV	+0.04	10.4
564.5	5	1	0	0	IFV-IWV	+0.29	11.2

Note: IFV = intermittent submerged vortex on floor; IWV = intermittent submerged vortex on wall; and + = clockwise rotation.

Water temperature = 85°-89° F; air temperature = 83°-89° F.

\* See Figure 4, page 13, for explanation of vortex stages.

\*\* Percent duration of vortex type during period of observation.

Table 17  
Sump Performance, Type 2 Design Sump

Sump El ft NGVD	Pumps Operating	Pump Bay No.	Surface Vortex		Submerged Vortex	Swirl-Rotational Flow Indicator	Maximum Pressure Fluctuation Feet of Water																																																																		
			Stage*	Percent**																																																																					
558.5	1	5	B	12	IFV	+0.02	1.2																																																																		
			C	13				559.5	1	5	B	11	IFV	+0.05	1.6	C	6	560.5	1	5	A	5	0	+0.13	2.0	561.5	1	5	O		0	+0.07	1.6	560.5	3	1	B	19	FV	-0.23	4.8	C	10	B	20	FV+IWV	C	5	B	25	FV	C	27	561.5	3	1	B	30	FV	-0.21	5.6	C	7	O		IFV+IWV	B	15	FV	C	7		
559.5	1	5	B	11	IFV	+0.05	1.6																																																																		
			C	6				560.5	1	5	A	5	0	+0.13	2.0	561.5	1	5	O		0	+0.07	1.6	560.5	3	1	B	19	FV	-0.23	4.8	C	10				B	20				FV+IWV	C	5	B		25	FV	C	27		561.5	3				1	B				30	FV	-0.21	5.6		C	7		O		IFV+IWV	B
560.5	1	5	A	5	0	+0.13	2.0																																																																		
561.5	1	5	O		0	+0.07	1.6																																																																		
560.5	3	1	B	19	FV	-0.23	4.8																																																																		
			C	10																																																																					
			B	20				FV+IWV																																																																	
			C	5																																																																					
			B	25					FV																																																																
			C	27																																																																					
561.5	3	1	B	30	FV	-0.21	5.6																																																																		
			C	7																																																																					
			O					IFV+IWV																																																																	
			B	15						FV																																																															
C	7																																																																								

(Continued)

Note: FV = submerged vortex on floor; WV = submerged vortex on wall; IFV = intermittent submerged vortex on floor; IWV = intermittent submerged vortex on wall; + = clockwise rotation; and - = counterclockwise rotation.

Water temperature = 80°-101° F; air temperature = 75°-87° F.

\* See Figure 4, page 13, for explanation of vortex stages.

\*\* Percent duration of vortex type during period of observation.

Table 17 (Concluded)

Sump El ft NGVD	Pumps Operating	Pump Bay No.	Surface Vortex		Submerged Vortex	Swirl-Rotational Flow Indicator	Maximum Pressure Fluctuation Feet of Water
			Stage	Percent			
562.5	3	1	0		FV+IWV	-0.27	6.0
		2	0		FV+IWV	+0.18	2.0
		3	0		FV+IWV	-0.12	10.8
562.0	5	1	0		FV+IWV	-0.48	5.2
		2	B	1	FV+IWV	-0.50	4.0
		3	0		FV+IWV	+0.47	5.2
		4	B	1	FV+IWV	+0.58	--
		5	0		FV+IWV	+0.58	4.8
563.0	5	1	0		FV+IWV	-0.48	7.2
		2	0		FV+IWV	-0.66	5.2
		3	0		FV+IWV	+0.58	6.0
		4	0		FV+IWV	+0.58	--
		5	0		FV+IWV	+0.58	6.8
564.5	5	1	0		FV+IWV	+0.42	1.2
		2	0		FV+IWV	0.32	0.8
		3	0		FV+WV	+0.55	6.0
		4	0		FV+WV	+0.40	--
		5	0		FV+WV	+0.20	1.2

Table 18

Sump Performance, Type 2 Design Sump, Type 1 Design Sill

Sump El ft NGVD	Pumps Operating	Pump Bay No.	Surface Vortex Stage*	Percent**	Submerged Vortex	Swirl-Rotational Flow Indicator	Maximum Pressure Fluctuation Feet of Water
558.5	1	5	D	26	IFV+IWV	+0.08	1.0
559.5	1	5	D	15	IFV+IWV	+0.12	1.1
560.5	1	5	B	5	0	+0.10	1.1
561.5	1	5	A	28	IFV	-0.12	1.1
562.0	5	1	C	2	FV+IWV	-0.53	6.0
		2	B	3	IFV+IWV	-0.26	--
		3	B	2	IFV+IWV	±0.29	4.8
		4	B	3	IFV+IWV	+0.12	2.0
		5	C	5	FV+IWV	+0.39	8.4
563.0	5	1	0		FV+IWV	-0.52	4.4
		2	0		IFV+IWV	-0.25	2.0
		3	0		IFV	±0.26	5.6
		4	0		IFV	+0.30	1.6
		5	0		FV	+0.70	4.8
564.5	5	1	0		IFV	-0.09	1.2
		2	0		IFV	-0.12	0.8
		3	0		IFV+IWV	±0.24	0.8
		4	0		IFV	+0.25	0.8
		5	0		IFV	+0.14	0.8

Note: FV = submerged vortex on floor; IFV = intermittent submerged vortex on floor; IWV = intermittent submerged vortex on wall; + = clockwise rotation; - = counterclockwise rotation; and ± = alternating rotation.  
Water temperature = 67°-87° F; air temperature = 69°-84° F.

\* See Figure 4, page 13, for explanation of vortex stages.

\*\* Percent duration of vortex type during period of observation.

Table 19  
Sump Performance, Type 2 Design Sump, Type 2 Design Sill

Sump El ft NGVD	Pumps Operating	Pump Bay No.	Surface Vortex Stage*	Surface Vortex Percent**	Submerged Vortex	Swirl-Rotational Flow Indicator	Maximum Pressure Fluctuation Feet of Water
558.5	1	1	C D	5 17	0	+0.06	0.8
559.5	1	1	C D	20 5	0	+0.08	0.8
560.5	1	1	0		IFV	+0.35	1.1
561.5	1	1	0		IFV	+0.44	3.4
562.0	5	1	B C	19 27	FV	-0.25	7.2
563.0	5	1	0		FV	-0.58	6.8
564.5	5	1	0		FV	-0.58	6.8

Note: FV = submerged vortex on floor; IFV = intermittent submerged vortex on floor; + = clockwise rotation; and - = counterclockwise rotation.

Water temperature = 82°-104° F; air temperature = 72°-82° F.

\* See Figure 4, page 13, for explanation of vortex stages.

\*\* Percent duration of vortex type during period of observation.

Table 20

## Sump Performance, Type 2 Design Sump, Type 6 Design Baffles

Sump El ft NGVD	Pumps Operating	Pump Bay No.	Surface Vortex		Submerged Vortex	Swirl-Rotational Flow Indicator	Maximum Pressure Fluctuation Feet of Water
			Stage*	Percent**			
558.5	1	5	D	24	IFV	+0.19	1.3
559.5	1	5	B	24	IFV	+0.18	1.9
560.5	1	5	B	4	IFV	+0.19	2.1
561.5	1	5	0	0	IFV	+0.14	1.6
562.0	5	1	0	0	FV+IWV	+0.21	1.6
		2	0	0	FV+IWV	-0.37	5.2
		3	0	0	IFV+IWV	+0.19	5.2
		4	0	0	FV+IWV	+0.29	8.0
		5	0	0	FV+IWV	-0.17	3.2
563.0	5	1	0	0	FV+IWV	+0.26	6.8
		2	0	0	FV+IWV	-0.46	5.2
		3	0	0	IFV+IWV	+0.34	4.4
		4	0	0	FV+IWV	+0.42	3.6
		5	0	0	IFV+IWV	-0.24	3.6
564.5	5	1	0	0	FV+IWV	+0.38	8.8
		2	0	0	FV+IWV	-0.46	1.0
		3	0	0	IFV+IWV	+0.17	3.6
		4	0	0	FV+IWV	+0.51	4.0
		5	0	0	IFV+IWV	-0.11	1.6

Note: FV = submerged vortex on floor; IFV = intermittent submerged vortex on floor; IWV = intermittent submerged vortex on wall; + = clockwise rotation; and - = counterclockwise rotation.

Water temperature = 73°-83° F; air temperature = 70°-90° F.

\* See Figure 4, page 13, for explanation of vortex stages.

\*\* Percent duration of vortex type during period of observation.

Table 21  
 Sump Performance, Type 2 Design Sump, Type 2 Design Gates

Sump El ft NGVD	Pumps Operating	Pump Bay No.	Surface Vortex		Submerged Vortex	Swirl-Rotational Flow Indicator	Maximum Pressure Fluctuation Feet of Water																																																																																																										
			Stage*	Percent**																																																																																																													
558.5	1	5	C	10	IFV-IWV	+0.19	2.3																																																																																																										
			D	18				559.5	1	5	C	6	IFV	+0.05	2.2	D	4	560.5	1	5	B	4	IFV	+0.10	1.6	C	2	561.5	1	5	0		IFV	+0.38	3.5	562.0	5	1	0		IFV+IWV	+0.27	1.2	0		IFV+IWV	+0.41	3.6	0		IFV+IWV	±0.06	1.6	0		IFV+IWV	-0.36	6.0	0		IFV+IWV	-0.29	2.8	563.0	5	1	0		IFV+IWV	-0.23	2.4	0		IFV+IWV	+0.44	4.8	0		IFV+IWV	+0.06	5.2	0		IFV+IWV	+0.20	6.0	0		IFV+IWV	-0.17	2.8	564.5	5	1	0		IFV+IWV	+0.44	3.4	0		IFV+IWV	+0.12	3.6	0		IFV+IWV	±0.12	2.4	0		IFV+IWV	+0.10
559.5	1	5	C	6	IFV	+0.05	2.2																																																																																																										
			D	4				560.5	1	5	B	4	IFV	+0.10	1.6	C	2	561.5	1	5	0		IFV	+0.38	3.5	562.0	5	1	0		IFV+IWV	+0.27	1.2	0					IFV+IWV	+0.41	3.6	0		IFV+IWV	±0.06	1.6	0		IFV+IWV	-0.36	6.0	0		IFV+IWV	-0.29	2.8	563.0	5	1	0		IFV+IWV	-0.23				2.4	0		IFV+IWV	+0.44	4.8	0		IFV+IWV	+0.06	5.2	0		IFV+IWV	+0.20	6.0	0		IFV+IWV	-0.17	2.8	564.5	5	1	0					IFV+IWV	+0.44	3.4	0		IFV+IWV	+0.12	3.6	0		IFV+IWV	±0.12	2.4	0		IFV+IWV	+0.10	0.8
560.5	1	5	B	4	IFV	+0.10	1.6																																																																																																										
			C	2				561.5	1	5	0		IFV	+0.38	3.5	562.0	5	1	0		IFV+IWV	+0.27	1.2	0					IFV+IWV	+0.41	3.6	0		IFV+IWV	±0.06				1.6	0		IFV+IWV	-0.36	6.0	0		IFV+IWV	-0.29	2.8	563.0	5	1	0		IFV+IWV	-0.23				2.4	0		IFV+IWV				+0.44	4.8	0		IFV+IWV	+0.06	5.2	0		IFV+IWV	+0.20	6.0	0		IFV+IWV	-0.17	2.8	564.5	5	1	0								IFV+IWV	+0.44	3.4	0		IFV+IWV	+0.12	3.6	0		IFV+IWV	±0.12	2.4	0		IFV+IWV	+0.10	0.8	0
561.5	1	5	0		IFV	+0.38	3.5																																																																																																										
562.0	5	1	0		IFV+IWV	+0.27	1.2																																																																																																										
			0		IFV+IWV	+0.41	3.6																																																																																																										
			0		IFV+IWV	±0.06	1.6																																																																																																										
			0		IFV+IWV	-0.36	6.0																																																																																																										
			0		IFV+IWV	-0.29	2.8																																																																																																										
563.0	5	1	0		IFV+IWV	-0.23	2.4																																																																																																										
			0		IFV+IWV	+0.44	4.8																																																																																																										
			0		IFV+IWV	+0.06	5.2																																																																																																										
			0		IFV+IWV	+0.20	6.0																																																																																																										
			0		IFV+IWV	-0.17	2.8																																																																																																										
564.5	5	1	0		IFV+IWV	+0.44	3.4																																																																																																										
			0		IFV+IWV	+0.12	3.6																																																																																																										
			0		IFV+IWV	±0.12	2.4																																																																																																										
			0		IFV+IWV	+0.10	0.8																																																																																																										
			0		FV	-0.13	3.6																																																																																																										

Note: FV = submerged vortex on floor; IFV = intermittent submerged vortex on floor; IWV = intermittent submerged vortex on wall; + = clockwise rotation; - = counterclockwise rotation; and ± = alternating rotation.  
 Water temperature = 78°-92° F; air temperature = 71°-82° F.  
 \* See Figure 4, page 13, for explanation of vortex stages.  
 \*\* Percent duration of vortex type during period of observation.

Table 22

## Sump Performance, Type 2 Design Sump, Type 3 Design Sidewalls, Type 2 Design Gates

Sump El ft NGVD	Pumps Operating	Pump Bay No.	Surface Vortex		Submerged Vortex	Swirl-Rotational Flow Indicator	Maximum Pressure Fluctuation Feet of Water
			Stage*	Percent**			
558.5	1	5	C	10	0	±0.04	1.4
			D	2			
559.5	1	5	C	3	0	+0.06	1.4
			D	1			
560.5	1	5	B	3	0	±0.07	1.4
			C	15			
561.5	1	5	0	0	0	+0.27	1.2
562.0	5	5	0	0	0	+0.11	1.2
563.0	5	5	0	0	0	-0.06	1.2
564.5	5	5	0	0	0	±0.10	3.4

Note: + = clockwise rotation; - = counterclockwise rotation; and ± = alternating rotation.

Water temperature = 73°-82° F; air temperature = 83°-93° F.

\* See Figure 4, page 13, for explanation of vortex stages.

\*\* Percent duration of vortex type during period of observation.

Table 23  
Sump Performance, Type 3 Design Sump

Sump El ft NGVD	Pumps Operating	Pump Bay No.	Surface Vortex	Submerged Vortex	Swirl-Rotational Flow Indicator	Maximum Pressure Fluctuation Feet of Water
558.5	1	5	0	0	+0.16	1.8
559.5	1	5	0	0	+0.26	1.3
560.5	1	5	0	0	+0.14	1.3
561.5	1	5	0	0	+0.12	2.1
560.5	3	5	0	0	-0.29	1.1
561.5	3	5	0	0	-0.21	1.2
562.5	3	5	0	0	-0.15	1.8
562.0	5	5	0	0	-0.45	3.0
563.0	5	5	0	0	-0.31	2.8
564.5	5	5	0	0	-0.23	1.2

Note: + = clockwise rotation; and - = counterclockwise rotation.  
 Water temperature = 80°-104° F; air temperature = 75°-93° F.

Table 24  
Sump Performance, Type 3 Design Sump with Trash Racks

<u>Sump El ft NGVD</u>	<u>Pumps Operating</u>	<u>Pump Bay No.</u>	<u>Surface Vortex</u>	<u>Submerged Vortex</u>	<u>Swirl-Rotational Flow Indicator</u>	<u>Maximum Pressure Fluctuation Feet of Water</u>
558.5	1	5	0	0	+0.08	1.2
559.5	1	5	0	0	+0.10	0.6
560.5	1	5	0	0	+0.12	0.8
561.5	1	5	0	0	+0.03	1.2
560.5	3	5	0	0	+0.08	1.2
561.5	3	5	0	0	-0.15	1.0
562.5	3	5	0	0	+0.27	1.6
562.0	5	5	0	0	+0.25	1.6
563.0	5	5	0	0	+0.19	1.6
564.5	5	5	0	0	+0.01	1.2

Note: + = clockwise rotation; and - = counterclockwise rotation.  
 Water temperature = 87°-104° F; air temperature = 82°-95° F.

Table 25  
Swirl in Pump Bay 5, Type 3 Design Sump with Trashracks, Type 3-18 Design Gates

Sump El ft NGVD	Pumps Operating	Swirl--Rotational Flow Indicator															
		Type 3	Type 4	Type 5	Type 6	Type 7	Type 8	Type 9	Type 10	Type 11	Type 12	Type 13	Type 14	Type 15	Type 16	Type 17	Type 18
		5 x 7* 2.25 ft**	5 x 8 2.25 ft	5 x 8 1.42 ft	5 x 8 0.67 ft	6 x 8 0.67 ft	3.5 x 9 2.25 ft	No Gates	4.5 x 8 3.0 ft	4.5 x 8* 2.25 ft**	4.5 x 8 1.42 ft	4 x 8 3.0 ft	4 x 8 2.5 ft	4 x 8 1.83 ft	4 x 8 2.25 ft	3.75 x 8 3.0 ft	3.75 x 8 2.25 ft
558.5	1	0.03	0.06	0.06	0.05	0.05	0.10	0.01	0.08								
559.5	1	0.06	0.04	0.03	0.03	0.04	0.01	0.02	0.05								
560.5	1	0.02	0.05	0.03	0.02	0.05	0.04	0.02	0.04								
561.5	1	0.04	0.03	0.03	0.03	0.05	0.01	0.01	0.02								
560.5	3†	0.13	0.12	0.14	0.17	0.16	0.11	0.04	0.13								
561.5	3†	0.14	0.11	0.12	0.14	0.14	0.01	0.15	0.12								
562.5	3†	0.06	0.06	0.10	0.13	0.10	0.13	0.18	0.15								
562.0	5	0.14	0.11	0.07	0.12	0.07	0.09	0.12	0.09								
563.0	5	0.09	0.05	0.06	0.02	0.13	0.10	0.22	0.08								
564.5	5	0.11	0.13	0.13	0.09	0.08	0.10	0.18	0.06								
558.5	1	0.11	0.06	0.04	0.08	0.10	0.10	0.04	0.04								
559.5	1	0.10	0.05	0.03	0.06	0.07	0.07	0.07	0.02								
560.5	1	0.04	0.04	0.02	0.03	0.02	0.03	0.03	0.01								
561.5	1	0.04	0.02	0.00	0.03	0.03	0.04	0.01	0.01								
560.5	3†	0.10	0.12	0.12	0.08	0.09	0.07	0.16	0.08								
561.5	3†	0.10	0.06	0.09	0.08	0.06	0.04	0.07	0.04								
562.5	3†	0.05	0.05	0.20	0.06	0.04	0.03	0.06	0.08								
562.0	5	0.07	0.02	0.07	0.06	0.01	0.02	0.12	0.08								
563.0	5	0.05	0.03	0.08	0.07	0.02	0.03	0.03	0.06								
564.5	5	0.07	0.06	0.05	0.03	0.02	0.02	0.02	0.10								

\* Gate opening, ft.

\*\* Gate location--distance from vertical drop to upstream face of gate, ft.

† Pumps 3, 4, and 5 operating.

Table 26  
Maximum Pressure Fluctuations in Pump Bay 5, Type 3 Design Sump with Trashracks  
Type 10-18 Design Gates

Sump EI ft NGVD	Pumps Operating	Maximum Pressure Fluctuation, Feet of Water									
		Type 10 4.5 x 8* 3.0 ft**	Type 11 4.5 x 8 2.25 ft	Type 12 4.5 x 8 1.42 ft	Type 13 4 x 8 3.0 ft	Type 14 4 x 8 2.5 ft	Type 15 4 x 8 2.25 ft	Type 16 4 x 8 1.83 ft	Type 17 3.75 x 8 3.0 ft	Type 18 3.75 x 8 2.25 ft	
558.5	1	0.8	1.2	2.2	2.4	1.6	1.0	1.4	4.0	2.0	
559.5	1	2.2	1.2	3.0	1.0	1.6	1.0	1.6	1.6	1.4	
560.5	1	2.0	1.6	2.2	1.2	1.0	1.6	1.2	2.8	1.6	
561.5	1	1.6	1.2	2.0	1.0	1.6	1.6	1.6	2.2	1.8	
560.5	3†	0.8	1.2	3.2	1.0	1.2	2.6	4.0	0.8	2.6	
561.5	3†	1.6	1.2	2.0	2.0	1.2	1.0	1.2	1.6	1.8	
562.5	3†	2.0	1.6	2.4	1.4	1.6	1.8	2.0	1.2	2.8	
562.0	5	1.4	1.2	1.2	1.2	1.2	2.6	2.0	1.2	1.2	
563.0	5	1.2	1.2	4.2	1.0	3.2	1.6	1.2	1.8	2.2	
564.5	5	1.2	1.2	2.0	1.2	1.0	0.8	1.2	1.6	1.4	

\* Gate opening, ft.  
 \*\* Gate location--distance from vertical drop to upstream face of gate, ft.  
 † Pumps 3, 4, and 5 operating.

Table 27  
Sump Performance, Type 3 Design Sump with Trashracks,  
Type 11 Design Gates, 1 Pump Operating

<u>Sump El ft NGVD</u>	<u>Pump Bay No.</u>	<u>Surface Vortex</u>	<u>Submerged Vortex</u>	<u>Swirl-Rotational Flow Indicator</u>	<u>Maximum Pressure Fluctuation Feet of Water</u>
558.5	5	0	0	+0.08	2.0
559.5	5	0	0	+0.03	2.4
560.5	5	0	0	+0.05	2.2
561.5	5	0	0	+0.02	2.0
558.5	4	0	0	+0.10	0.6
559.5	4	0	0	+0.06	0.6
560.5	4	0	0	+0.05	0.4
561.5	4	0	0	+0.04	0.4
558.5	3	0	0	+0.08	0.6
559.5	3	0	0	+0.04	0.8
560.5	3	0	0	+0.02	0.8
561.5	3	0	0	+0.01	0.6

---

Note: + = clockwise rotation.  
 Water temperature = 85°-90° F; air temperature = 80°-87° F.

Table 28  
Sump Performance, Type 3 Design Sump with Trashracks,  
Type 11 Design Gates, 2 Pumps Operating

<u>Sump El ft NGVD</u>	<u>Pump Bay No.</u>	<u>Surface Vortex</u>	<u>Submerged Vortex</u>	<u>Swirl-Rotational Flow Indicator</u>	<u>Maximum Pressure Fluctuation Feet of Water</u>
559.5	4	0	0	-0.08	0.8
	5	0	0	+0.12	2.2
560.5	4	0	0	-0.08	0.4
	5	0	0	+0.14	1.2
561.5	4	0	0	-0.02	0.4
	5	0	0	+0.06	2.4
562.5	4	0	0	-0.04	0.4
	5	0	0	+0.08	3.2
559.5	3	0	0	-0.06	0.4
	5	0	0	+0.13	1.2
560.5	3	0	0	-0.04	0.4
	5	0	0	+0.13	1.6
561.5	3	0	0	-0.04	0.4
	5	0	0	+0.08	3.6
562.5	3	0	0	-0.04	0.4
	5	0	0	+0.05	3.6
599.5	1	0	0	-0.15	2.0
	5	0	0	+0.12	2.0
560.5	1	0	0	-0.12	1.2
	5	0	0	+0.13	2.0
561.5	1	0	0	-0.13	1.2
	5	0	0	+0.09	3.2
562.5	1	0	0	-0.12	1.2
	5	0	0	+0.05	4.0
559.5	2	0	0	-0.09	0.4
	4	0	0	+0.20	0.4
560.5	2	0	0	-0.05	0.4
	4	0	0	+0.13	0.4
561.5	2	0	0	-0.06	0.4
	4	0	0	+0.12	0.4

(Continued)

Note: + = clockwise rotation; and - = counterclockwise rotation.  
 Water temperature = 79°-103° F; air temperature = 76°-96° F.

Table 28 (Concluded)

<u>Sump El ft NGVD</u>	<u>Pump Bay No.</u>	<u>Surface Vortex</u>	<u>Submerged Vortex</u>	<u>Swirl-Rotational Flow Indicator</u>	<u>Maximum Pressure Fluctuation Feet of Water</u>
562.5	2	0	0	-0.05	0.4
	4	0	0	+0.11	0.4
559.5	3	0	0	-0.09	0.4
	4	0	0	+0.20	0.4
560.5	3	0	0	-0.05	0.4
	4	0	0	+0.13	0.4
561.5	3	0	0	-0.05	0.4
	4	0	0	+0.10	0.4
562.5	3	0	0	-0.04	0.6
	4	0	0	+0.10	0.4

Table 29  
Sump Performance, Type 3 Design Sump with Trashracks,  
Type 11 Design Gates, 3 Pumps Operating

Sump El ft NGVD	Pump Bay No.	Surface Vortex	Submerged Vortex	Swirl-Rotational Flow Indicator	Maximum Pressure Fluctuation Feet of Water
560.5	3	0	0	-0.05	0.8
	4	0	0	+0.04	0.8
	5	0	0	+0.08	2.4
561.5	3	0	0	-0.05	0.5
	4	0	0	+0.02	1.4
	5	0	0	+0.08	2.6
562.5	3	0	0	-0.06	0.4
	4	0	0	+0.06	0.6
	5	0	0	+0.05	2.2
563.5	3	0	0	-0.05	0.6
	4	0	0	+0.05	0.4
	5	0	0	+0.05	2.4
560.5	2	0	0	-0.11	0.4
	4	0	0	+0.02	0.8
	5	0	0	+0.07	1.4
561.5	2	0	0	-0.08	1.4
	4	0	0	+0.01	1.4
	5	0	0	-0.04	3.4
562.5	2	0	0	+0.11	0.4
	4	0	0	+0.03	0.4
	5	0	0	+0.04	2.0
563.5	2	0	0	-0.12	0.4
	4	0	0	-0.05	0.4
	5	0	0	+0.04	2.4
560.5	1	0	0	-0.11	1.4
	4	0	0	+0.05	2.6
	5	0	0	+0.08	2.0
561.5	1	0	0	-0.08	1.4
	4	0	0	+0.04	1.6
	5	0	0	+0.08	3.6
562.5	1	0	0	-0.04	1.2
	4	0	0	+0.05	0.6
	5	0	0	+0.05	4.0

(Continued)

Note: + = clockwise rotation; and - = counterclockwise rotation.  
 Water temperature = 84°-105° F; air temperature = 76°-97° F.

Table 29 (Concluded)

<u>Sump El ft NGVD</u>	<u>Pump Bay No.</u>	<u>Surface Vortex</u>	<u>Submerged Vortex</u>	<u>Swirl-Rotational Flow Indicator</u>	<u>Maximum Pressure Fluctuation Feet of Water</u>
563.5	1	0	0	-0.12	0.8
	4	0	0	+0.07	0.4
	5	0	0	+0.04	3.6
560.5	2	0	0	-0.11	0.4
	3	0	0	+0.09	1.4
	4	0	0	+0.16	0.6
561.5	2	0	0	-0.08	0.8
	3	0	0	+0.03	0.4
	4	0	0	+0.12	0.8
562.5	2	0	0	-0.09	0.4
	3	0	0	-0.02	0.8
	4	0	0	+0.14	0.6
563.5	2	0	0	-0.10	0.4
	3	0	0	-0.02	0.8
	4	0	0	+0.16	0.6

Table 30  
Sump Performance, Type 3 Design Sump with Trashracks,  
Type 11 Design Gates, 4 Pumps Operating

<u>Sump El ft NGVD</u>	<u>Pump Bay No.</u>	<u>Surface Vortex</u>	<u>Submerged Vortex</u>	<u>Swirl-Rotational Flow Indicator</u>	<u>Maximum Pressure Fluctuation Feet of Water</u>
561.5	2	0	0	-0.08	0.4
	3	0	0	-0.03	2.0
	4	0	0	+0.03	1.2
	5	0	0	+0.06	2.8
562.5	2	0	0	-0.13	0.4
	3	0	0	-0.03	1.6
	4	0	0	+0.08	0.6
	5	0	0	+0.05	2.8
563.5	2	0	0	-0.13	0.4
	3	0	0	+0.02	0.4
	4	0	0	+0.08	0.5
	5	0	0	+0.05	2.0
561.5	1	0	0	-0.09	1.2
	3	0	0	-0.02	0.6
	4	0	0	+0.02	0.8
	5	0	0	+0.10	1.6
562.5	1	0	0	-0.09	1.2
	3	0	0	-0.04	0.6
	4	0	0	+0.08	0.6
	5	0	0	+0.04	2.4
563.5	1	0	0	-0.12	1.0
	3	0	0	-0.05	0.8
	4	0	0	+0.09	0.6
	5	0	0	+0.05	2.0
561.5	1	0	0	-0.08	1.6
	2	0	0	-0.02	0.4
	4	0	0	+0.05	0.6
	5	0	0	+0.10	2.8
562.5	1	0	0	-0.09	2.0
	2	0	0	-0.02	0.4
	4	0	0	+0.07	0.6
	5	0	0	+0.04	2.0
563.5	1	0	0	-0.14	0.8
	2	0	0	±0.01	0.4
	4	0	0	+0.05	0.4
	5	0	0	+0.04	3.8

Note: + = clockwise rotation; - = counterclockwise rotation; and ± = alternating rotation.

Water temperature = 94°-105° F; air temperature = 80°-94° F.

Table 31  
Sump Performance, Type 3 Design Sump with Trashracks,  
Type 11 Design Gates, 5 Pumps Operating

<u>Sump El ft NGVD</u>	<u>Pump Bay No.</u>	<u>Surface Vortex</u>	<u>Submerged Vortex</u>	<u>Swirl-Rotational Flow Indicator</u>	<u>Maximum Pressure Fluctuation Feet of Water</u>
562.5	1	0	0	-0.07	1.2
	2	0	0	-0.05	0.4
	3	0	0	±0.01	0.6
	4	0	0	+0.04	1.0
	5	0	0	+0.08	1.2
563.5	1	0	0	-0.12	1.0
	2	0	0	+0.02	0.8
	3	0	0	-0.03	1.0
	4	0	0	+0.08	0.4
	5	0	0	+0.08	1.2
564.5	1	0	0	-0.11	1.2
	2	0	0	+0.05	0.4
	3	0	0	+0.02	0.6
	4	0	0	+0.03	0.8
	5	0	0	+0.04	1.2

Note: + = clockwise rotation; - = counterclockwise rotation; and ± = alternating rotation.  
 Water temperature = 89°-96° F; air temperature = 86°-91° F.

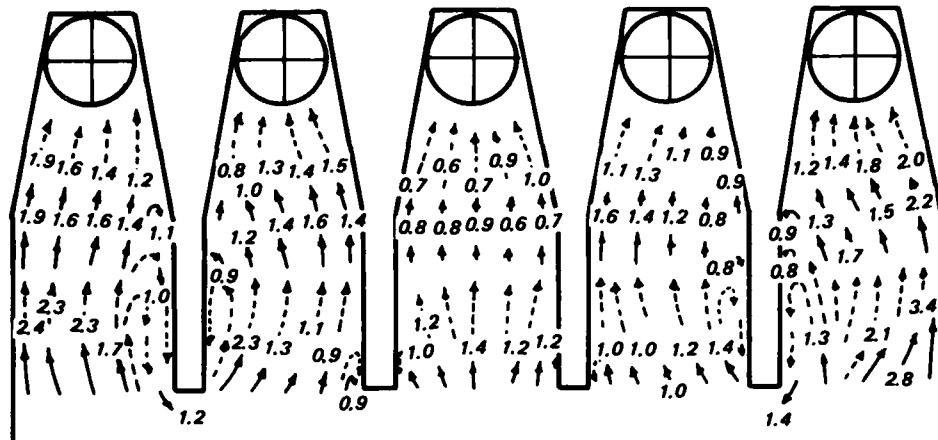

SUMP WATER-SURFACE EL 562.0 FT  
5 PUMPS OPERATING

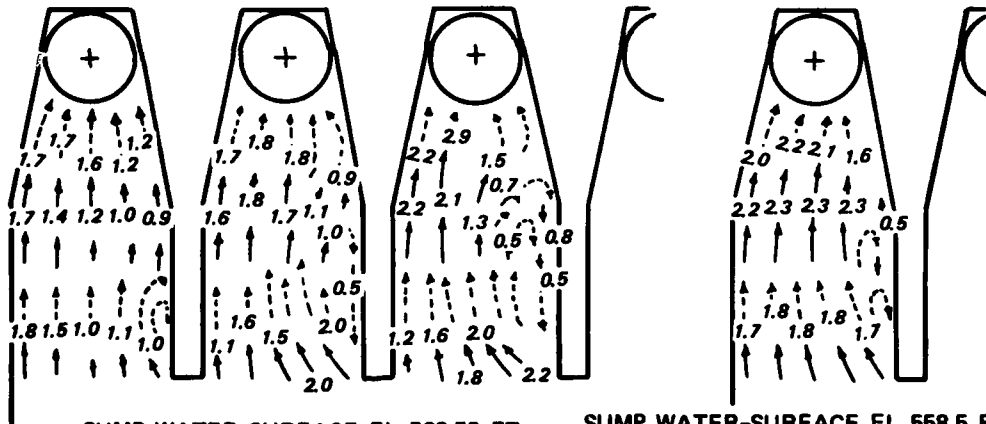

SUMP WATER-SURFACE EL 560.75 FT  
3 PUMPS OPERATING

SUMP WATER-SURFACE EL 558.5 FT  
1 PUMP OPERATING

**LEGEND**  
 ———→ MEASURED VELOCITY, FPS  
 - - - - -→ FLOW DIRECTION BASED ON DYE INJECTION

**TYPE 1 (ORIGINAL) DESIGN SUMP  
 VELOCITY MEASUREMENTS  
 1.25 FT FROM FLOOR**

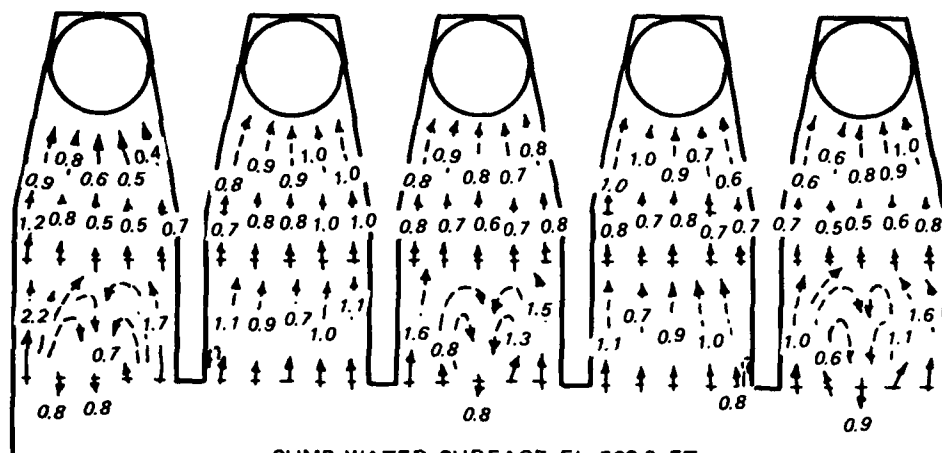

SUMP WATER-SURFACE EL 562.0 FT  
5 PUMPS OPERATING

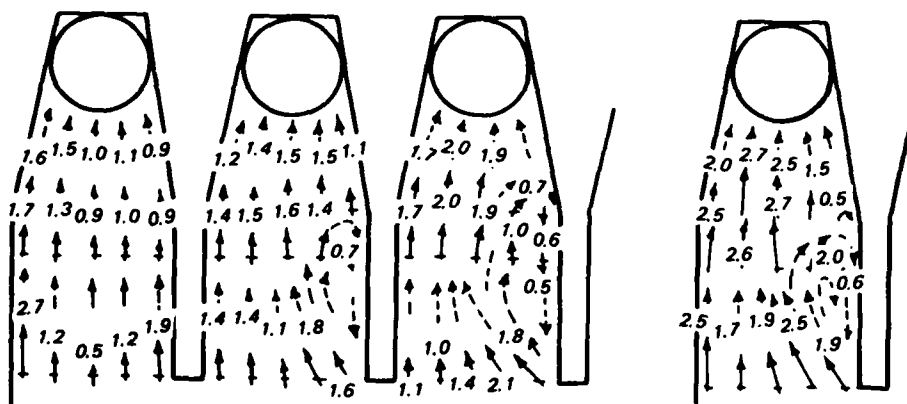

SUMP WATER-SURFACE EL 560.75 FT  
3 PUMPS OPERATING

SUMP WATER-SURFACE EL 558.5 FT  
1 PUMP OPERATING

**LEGEND**

- MEASURED VELOCITY, FPS
- - - FLOW DIRECTION BASED ON DYE INJECTION

**TYPE 2 DESIGN BAFFLES**  
VELOCITY MEASUREMENTS  
1.25 FT FROM FLOOR

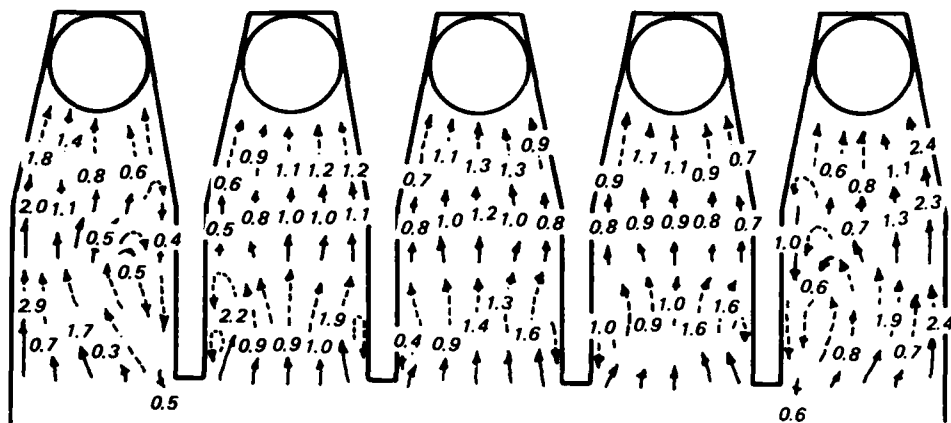

SUMP WATER-SURFACE EL 562.0 FT  
5 PUMPS OPERATING

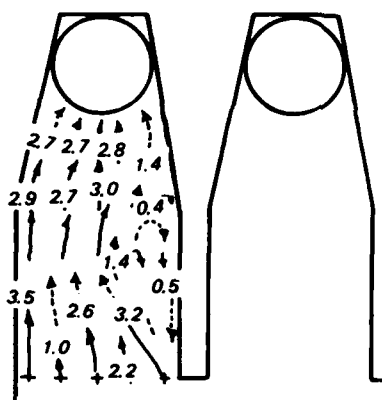

SUMP WATER-SURFACE EL 558.5 FT  
PUMP 5 OPERATING

**LEGEND**

- MEASURED VELOCITY, FPS
- - -→ FLOW DIRECTION BASED ON DYE INJECTION

**TYPE 3 DESIGN BAFFLES  
VELOCITY MEASUREMENTS  
1.25 FT FROM FLOOR**

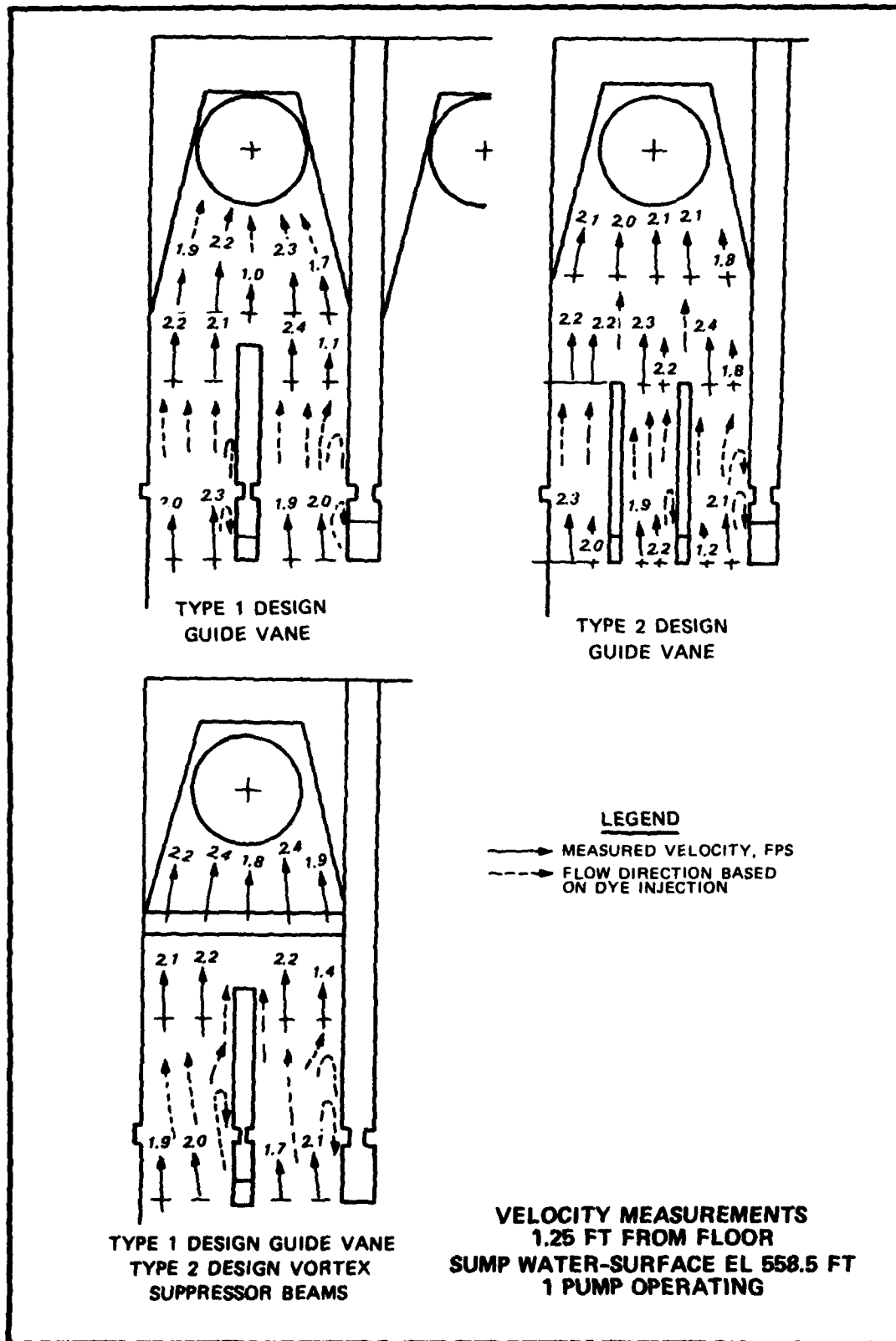
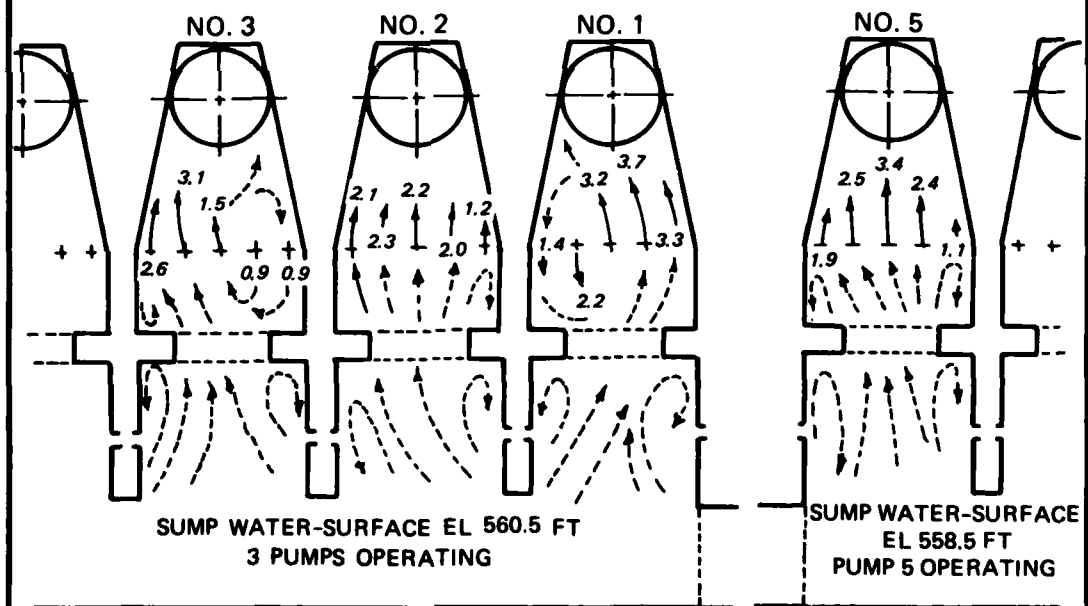
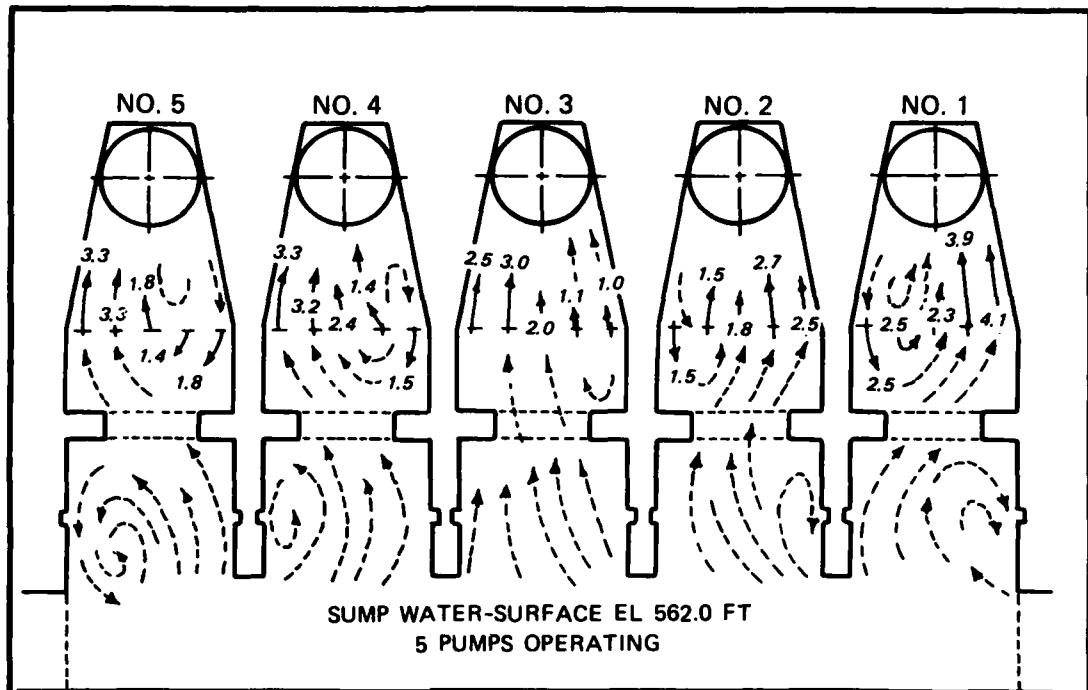

PLATE 4



**LEGEND**

- MEASURED VELOCITY, FPS
- - -→ FLOW DIRECTION BASED ON DYE INJECTION

**TYPE 2 DESIGN SUMP  
VELOCITY MEASUREMENTS  
1.25 FT FROM FLOOR**

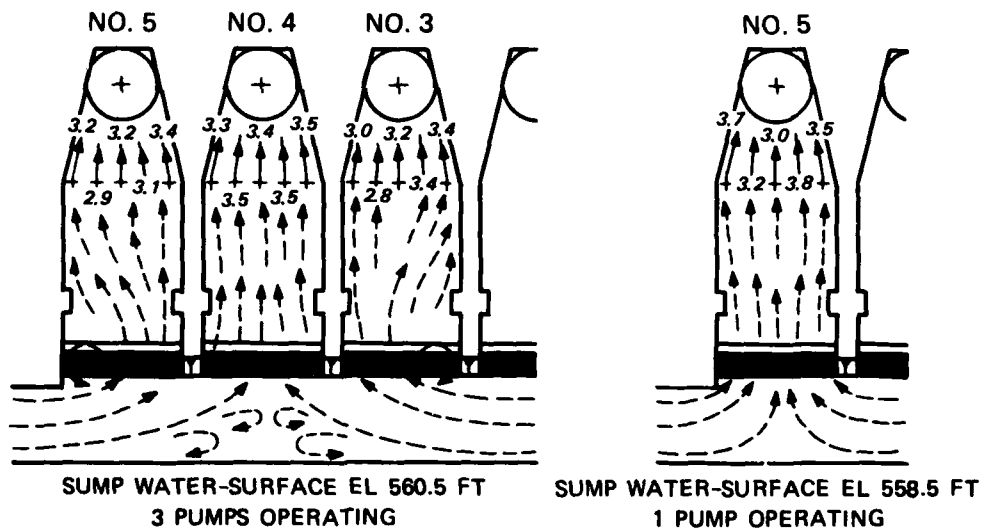
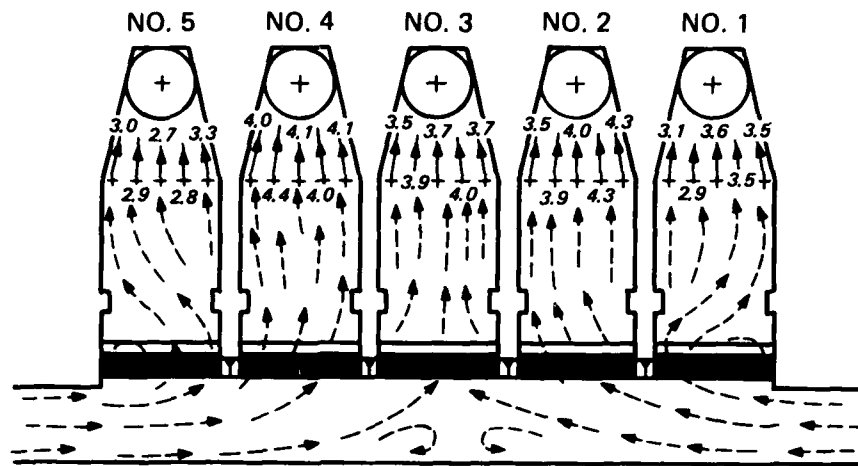

**LEGEND**

- MEASURED VELOCITY, FPS
- - -→ FLOW DIRECTION BASED ON DYE INJECTION

**TYPE 3 DESIGN SUMP  
WITH TRASHRACKS AND TYPE 11 DESIGN GATE  
VELOCITY MEASUREMENTS  
1.25 FT FROM FLOOR**

**IN  
DATE  
ILME**