



EARLY TRAINING ESTIMATION SYSTEM (ETES)  
FINAL REPORT  
APPENDIX G: USER'S GUIDE: SYSTEM DESCRIPTION TECHNOLOGY

Lawrence H. O'Brien and Robert Kistler  
Dynamics Research Corporation

Charles Jorgensen, Contracting Officer's Representative

Submitted by

Michael H. Strub, Chief  
ARI FIELD UNIT AT FORT BLISS, TEXAS

and

Jerrold M. Levine, Director  
SYSTEMS RESEARCH LABORATORY

**DTIC**  
**ELECTE**  
JUN 28 1984  
**S** **D**  
A



U. S. Army

Research Institute for the Behavioral and Social Sciences

June 1984

Approved for public release; distribution unlimited.

This report, as submitted by the contractor, has been cleared for release to Defense Technical Information Center (DTIC) to comply with regulatory requirements. It has been given no primary distribution other than to DTIC and will be available only through DTIC or other reference services such as the National Technical Information Service (NTIS). The views, opinions, and/or findings contained in this report are those of the author(s) and should not be construed as an official Department of the Army position, policy, or decision, unless so designated by other official documentation.

AD-A142 750  
DTIC FILE COPY

REPORT DOCUMENTATION PAGE		READ INSTRUCTIONS BEFORE COMPLETING FORM										
1. REPORT NUMBER Research Note 84-80	2. GOVT ACCESSION NO. A142 750	3. RECIPIENT'S CATALOG NUMBER										
4. TITLE (and Subtitle)  EARLY TRAINING ESTIMATION SYSTEM: FINAL REPORT APPENDIX G: USER'S GUIDE: SYSTEM DESCRIPTION TECHNOLOGY	5. TYPE OF REPORT & PERIOD COVERED  FINAL											
	6. PERFORMING ORG. REPORT NUMBER											
7. AUTHOR(s)  Lawrence H. O'Brien and Robert Kistler	8. CONTRACT OR GRANT NUMBER(s)  MDA-903-80-C-0525											
9. PERFORMING ORGANIZATION NAME AND ADDRESS  DYNAMICS RESEARCH CORPORATION 60 Concord Street Wilmington, Massachusetts 01887	10. PROGRAM ELEMENT, PROJECT, TASK AREA & WORK UNIT NUMBERS  2Q162722A791											
11. CONTROLLING OFFICE NAME AND ADDRESS  Army Research Institute 5001 Eisenhower Avenue Alexandria, Virginia 22333	12. REPORT DATE  June 1984											
	13. NUMBER OF PAGES  378											
14. MONITORING AGENCY NAME & ADDRESS (if different from Controlling Office)  US Army Research Institute for the Behavioral and Social Sciences Fort Bliss Field Unit, P.O. Box 6057 Fort Bliss, TX 79916	15. SECURITY CLASS. (of this report)  UNCLASSIFIED											
	15a. DECLASSIFICATION/DOWNGRADING SCHEDULE											
16. DISTRIBUTION STATEMENT (of this Report)  Approved for public release; distribution unlimited												
17. DISTRIBUTION STATEMENT (of the abstract entered in Block 20, if different from Report)												
18. SUPPLEMENTARY NOTES  Charles Jorgensen, Contracting Officers Representative												
19. KEY WORDS (Continue on reverse side if necessary and identify by block number)  <table border="0"> <tr> <td>Training</td> <td>Training Estimation</td> </tr> <tr> <td>Instructional System Development</td> <td>Simulation</td> </tr> <tr> <td>Data Base Management</td> <td>Training Effectiveness</td> </tr> <tr> <td>Task Analysis</td> <td>Training Effectiveness Analysis</td> </tr> <tr> <td></td> <td>Front End Analysis</td> </tr> </table>			Training	Training Estimation	Instructional System Development	Simulation	Data Base Management	Training Effectiveness	Task Analysis	Training Effectiveness Analysis		Front End Analysis
Training	Training Estimation											
Instructional System Development	Simulation											
Data Base Management	Training Effectiveness											
Task Analysis	Training Effectiveness Analysis											
	Front End Analysis											
20. ABSTRACT (Continue on reverse side if necessary and identify by block number)  <p>&gt; This report describes the research and development activities conducted under the Early Training Estimation System (ETES) development project. The Early Training Estimation System (ETES) is an integrated set of procedures and automated tools for estimating training requirements during the earliest phases of the weapon system acquisition process. The ETES has three major components; a System Description Technology (SDT), Early Training Estimation Aids and Procedures (TEAP), and Evaluative Technology. The SDT is a data base management system for storing and tracking task and training-related</p>												

PREFACE

This user's guide is part of the Early Training Estimation System (ETES). Development of the ETES was sponsored by the Army Research Institute (ARI) under contract No. MDA-903-80-C-0525. Dynamics Research Corporation (DRC) of Wilmington, Massachusetts was the contractor. The contract monitor for the project was Dr. Charles Jorgensen. The conceptual framework for the System Description Technology was developed by Dr. Lawrence O'Brien and Mr. Robert Kistler. Mr. Kistler developed the software for the System Description Technology (SDT).



Accession For	
GRA&I	<input checked="" type="checkbox"/>
TAB	<input type="checkbox"/>
Unpublished	<input type="checkbox"/>
Classification	
Distribution/	
Availability Codes	
Dist	Special
A1	

## TABLE OF CONTENTS

	Page
1. INTRODUCTION	1-1
1.1 Objectives	1-1
1.2 Potential Users	1-2
1.3 Conceptual Overview	1-2
1.4 Guidelines for Using this Guide	1-8
2. SDT EXAMPLE	2-1
3. SDT OPERATIONAL PROCEDURES	3-1
3.1 SDT Hardware	3-1
3.2 SDT Software Requirements	3-2
3.3 Using SDT Menus	3-7
3.4 SDT Help Aids	3-9
3.5 SDT Output Reports	3-9
4. SETTING UP AN SDT DATA BASE	4-1
5. INITIAL SDT MENUS AND FRAMES	5-1
5.1 SDT Introduction (SDT-1)	5-4
5.2 Select System (SDT-2)	5-6
5.3 System Description (SDT-3)	5-8
5.4 SDT Mode Select (SDT-4)	5-10

## TABLE OF CONTENTS (continued)

	Page
6. AUDIT/UPDATE MODE	6-1
6.1 Select Audit/Update Option (AU-1)	6-4
6.2 Enter Password (AU-2)	6-6
6.3 Action Completed Message (AU-3)	6-8
6.4 Select Screening Option (AU-4)	6-10
6.5 Select Audit Trail Items (AU-5)	6-12
6.6 Item Description (AU-6)	6-14
6.7 Select Entity Type (AU-7)	6-16
6.8 Enter Audit Trail Description (AU-8)	6-18
7. INPUT MODE	7-1
7.1 Select Input Entity (I-1)	7-4
7.2 Select Input Mode (I-2)	7-6
7.3 Select Attributes (I-3)	7-10
7.4 Select Level (I-4)	7-14
7.5 Select Specific Entities (I-3)	7-18
7.6 Enter Attributes (I-6)	7-20
7.7 Select Format (I-7)	7-28
8. CORRECT MODE	8-1
8.1 Select Correct Entity (C-1)	8-4
8.2 Select Specific Entity (C-2)	8-6
8.3 Select Attribute (C-3)	8-6
8.4 Modify Attribute (C-4)	8-10
8.5 Correct System Attribute (C-5)	8-14

TABLE OF CONTENTS (continued)

	Page
9. OUTPUT MODE	9-1
9.1 Select Output Entity (O-1)	9-4
9.2 Select Output Device (O-2)	9-6
9.3 Select Output Format (O-3)	9-8
9.4 Select Attribute (O-4)	9-10
9.5 Design Format (O-5)	9-12
9.6 Enter Column Heading (O-6)	9-20
9.7 Enter Output Heading (O-7)	9-22
9.8 Enter Report Name (O-8)	9-24
9.9 Select Specific Entities (O-9)	9-26
9.10 Select Level (O-10)	9-28
9.11 Output (O-11)	9-32
10. SAVE/RESTORE MODE	10-1
10.1 Select Save or Restore Option (RS-1)	10-4
10.2 Insert Backup Diskette (RS-2)	10-6
10.3 Saving (RS-3)	10-8
10.4 Restoring (RS-4)	10-10
11. APPLICATION MODE	11-1
12. AUXILIARY MODE	12-1
13. GUIDELINES FOR ENTERING DATA INTO THE SDT	13-1
A. Appendix A: SDT Structure	A-1
B. Appendix B: SDT Standard Output Reports	B-1

## LIST OF TABLES

Table		Page
1-1	SDT Data Elements	1-3
3-1	Standard SDT Output Formats	3-11
4-1	Worksheet for Setting up SDT Data Base	4-2
9-1	Acceptable Output Report Formats	9-14
9-2	Standard SDT Output Format	9-17
13-1	Guidelines for Entering SDT Data	13-2
13-2	Types of Acceptable Reports Involving Two or More Entities	13-28
A-1	SDT Data Dictionary	A-3
B-1	Standard SDT Output Formats	B-2
B-2	List of Output Reports	B-5

## LIST OF FIGURES

Figure		Page
1-1	SDT Architecture	1-5
1-2	Guidelines for Using SDT Users Guide	1-10
2-1	Inserting a Diskette	2-3
2-2	SDT Introduction (SDT-1)	2-5
2-3	System Selection	2-7
2-4	System Description (SDT-3)	2-9
2-5	Mode Select (SDT-4)	2-11
2-6	Select Output Entity (O-1)	2-13
2-7	Select Device (O-2)	2-15
2-8	Select Output Format (O-3)	2-17
2-9	Select Specific Entities (O-9)	2-19
2-10	Output (O-11)	2-21
2-11	Select Entity to be Output (O-1)	2-23
2-12	SDT Mode (SDT-4)	2-25
2-13	Select Correct Entity (C-1)	2-27
2-14	Select Specific Entities (C-2)	2-29
2-15	Select Attribute (C-3)	2-31
2-16	Modify Course Attribute (C-4)	2-33
3-1	The Apple III Keyboard	3-3
3-2	Inserting a Diskette	3-5
3-3	Typical SDT Menu	3-8
3-4	SDT Help Aids	3-10
5-1	Overview of Logic of Initial SDT Frames	5-2
5-2	SDT Introduction (SDT-1)	5-5
5-3	Select System (SDT-2)	5-7

## LIST OF FIGURES (continued)

Figure		Page
5-4	System Description (SDT-3)	5-9
5-5	SDT Mode Select (SDT-4)	5-11
6-1	Overview of Audit/Update Mode Logic	6-3
6-2	Select Audit/Update (AU-1)	6-5
6-3	Enter Password (AU-2)	6-7
6-4	Action Taken Message (AU-3)	6-9
6-5	Select Screening Option (AU-4)	6-11
6-6	Select Audit Trail Items (AU-5)	6-13
6-7	Item Description (AU-6)	6-15
6-8	Select Entity Type (AU-7)	6-17
6-9	Enter Audit Trail Description (AU-8)	6-19
7-1	Overview of Input Mode Logic	7-3
7-2	Select Input Entity (I-1)	7-5
7-3	Select Input Mode (I-2)	7-7
7-4	Select Attributes (I-3)	7-11
7-5	Select Level - Highest Level (I-4)	7-15
7-6	Select Level - Lowest Level (I-4)	7-16
7-7	Select Specific Entities (I-5)	7-19
7-8	Enter Attributes (I-6)	7-21
7-9	Enter Attributes (I-6)	7-22
7-10	Enter Attributes (I-6)	7-23
7-11	Enter Attributes (I-6)	7-24
7-12	Enter Attributes (I-6)	7-26
7-13	Select Format (I-7)	7-29

LIST OF FIGURES (continued)

Figure		Page
8-1	Overview of Correct Mode Logic	8-3
8-2	Select Correct Entity (C-1)	8-5
8-3	Select Specific Entity (C-2)	8-7
8-4	Select Attributes (C-3)	8-9
8-5	Modify Attributes (C-4)	8-11
8-6	Modify Attributes (C-4)	8-12
8-7	Correct System Attribute (C-5)	8-15
9-1	Overview of Output Mode Logic	9-3
9-2	Select Output Entity (O-1)	9-5
9-3	Select Output Device (O-2)	9-7
9-4	Select Output Format (O-3)	9-9
9-5	Select Attribute (O-4)	9-11
9-6	Design Format (O-5)	9-13
9-7	Enter Column Heading (O-6)	9-21
9-8	Enter Output Heading (O-7)	9-23
9-9	Enter Report Name (O-8)	9-25
9-10	Select Specific Entities (O-9)	9-27
9-11	Select Level - Highest Level (O-10)	9-29
9-12	Select Level - Lowest Level (O-10)	9-30
9-13	Output (O-11)	9-33
10-1	Overview of Save/Restore Mode Logic	10-2
10-2	Select Save or Restore Option (RS-1)	10-5
10-3	Input Diskette (RS-2)	10-7
10-4	Saving (RS-3)	10-9
10-5	Restoring (RS-4)	10-11

LIST OF FIGURES (continued)

Figure		Page
11-1	Select Applications Program (SDT-5)	11-2
12-1	Auxiliary Program Options	12-2
13-1	Overview of Hierarchical Relationships Among SDT Entities	13-26
A-1	Overview of Hierarchical Relationships Among SDT Elements	A-2

## SECTION 1- INTRODUCTION

### 1.1 Objectives

*from 1473* This user's guide provides detailed instructions on how to use the System Description Technology (SDT). The SDT is a microcomputer-based data base management system for: (1) describing actual and projected system elements including system functional requirements, system hardware and software concepts, tasks, skills, and training program elements and their associated resource and cost requirements, (2) storing the above information, (3) changing and updating this information, and (4) transmitting the information among all of the participants in the acquisition process. The SDT data base management system is designed to allow training developers to keep track of the many system changes which occur during the early phases of the acquisition process. In addition, it provides a centralized data base, thus eliminating the redundant data collection efforts which typically take place among the numerous training development organizations within the Army. ←

The techniques described in this guide are part of the Early Training Estimation System (ETES). An overview of the other components of ETES is provided in the ETES User's Guide. The ETES User's Guide describes how to develop the data which goes into the SDT. Users should examine this guide before using the SDT.

## 1.2 Potential Users

The SDT has been designed to be used by Army technical analysis who are directly concerned with training development for new Army Weapon Systems. The primary user organizations are expected to be: (1) the training developers in the Army schools associated with development of new systems (2) Program Manager's Office for new systems, particularly those individuals concerned with training development of Integrated Logistics Support, (3) the TRADOC System Manager (TSM), (4) other Army organizations concerned with training development such as the TRADOC Systems Analysis Activity (TRASANA) and PM TRADE, and (5) contractors who must develop training requirements for new systems. It is assumed that SDT users are familiar with the basic Army training development terminology and processes.

## 1.3 Conceptual Overview

To provide an effective communication vehicle for training developers and other participants in the acquisition process, the SDT has been designed to describe the following system elements: (1) functions, (2) missions, (3) hardware and software, (4) courses, (5) tasks, (6) personnel (duty positions), and (7) training media. A list of these system elements is provided in Table 1-1. More detailed breakdowns are provided in Appendix A.

### o SDT Architecture

The SDT may be used in either an independent or distributed processing mode. In the distributed processing mode, a

Table 1-1. SDT Data Elements.

Functional Requirements	Equipments	Duty Positions	Missions
<ul style="list-style-type: none"> <li>● System Performance Measures</li> <li>● Environmental Impacts</li> <li>● Threat Impacts</li> <li>● Function Sequence Information</li> </ul>	<ul style="list-style-type: none"> <li>● Equipment Breakdown Structure</li> <li>● Generic Family Reliability Data</li> <li>● Number Supported at Each Maintenance Level</li> <li>● Equipment Costs</li> <li>● System Information Flow</li> <li>● Software Requirements</li> </ul>	<ul style="list-style-type: none"> <li>● Occupational Specialties</li> <li>● Manpower Requirements (By Year)</li> <li>● Salary Requirements</li> <li>● Location in Organizational Structure</li> </ul>	<ul style="list-style-type: none"> <li>● Percent Operating Time</li> <li>● Annual Number</li> <li>● Annual Operating Days</li> </ul>
<p>Tasks</p> <ul style="list-style-type: none"> <li>● Task Element</li> <li>● Task Condition</li> <li>● Task Standard</li> <li>● Initiating Cues</li> <li>● Terminating Cues</li> <li>● Tools/Test Equipment</li> <li>● Failure Modes</li> <li>● Learning Objectives</li> <li>● Performance Measures</li> <li>● Skills and Knowledges</li> <li>● Training Emphasis Scales</li> </ul>	<p>Courses</p> <ul style="list-style-type: none"> <li>● Prerequisite Courses</li> <li>● Follow-On Courses</li> <li>● Course Costs</li> <li>● Student Input Requirements (By Year)</li> <li>● Modules <ul style="list-style-type: none"> <li>- Methods</li> <li>- Student/Instructor Ratios</li> </ul> </li> </ul>	<p>Media</p> <ul style="list-style-type: none"> <li>● Costs</li> <li>● Issue Rate</li> <li>● Type of Media</li> <li>● Training Assignments</li> </ul>	

centralized data base for each weapon system (or weapon system alternative) is stored on a mainframe computer (See Figure 1-1). At periodic intervals, users transfer a copy of the data base from the mainframe to a local micro-computer. Once on the micro, users perform standard data base management functions (input, output, modify). Thus, all major data base management functions can be performed independently on the microcomputer. Once users have completed their activities with the data base, they can transfer the updated version to the mainframe. A detailed "audit trail" is kept for each weapon system so that users can systematically track and assess system changes.

In the independent mode, a single user (or set of users) can develop and maintain the entire data base on a microcomputer (without interfacing with the mainframe).

#### o SECURITY

The SDT also has built-in security features which allow the SDT data base director to limit data input, modify, and output capabilities to a restricted set of users.

#### o SDT OPERATION

To provide a user-friendly interface, the SDT uses menu selection techniques for data item and command selection, and data output; and form-filling and question-and-answer dialogue techniques for data input.

Menu selection on the SDT is achieved by allowing users to move a highlighter up and down the screen in one of two ways: (1) by pressing the up or down arrow keys on the

# SYSTEM CONCEPTS

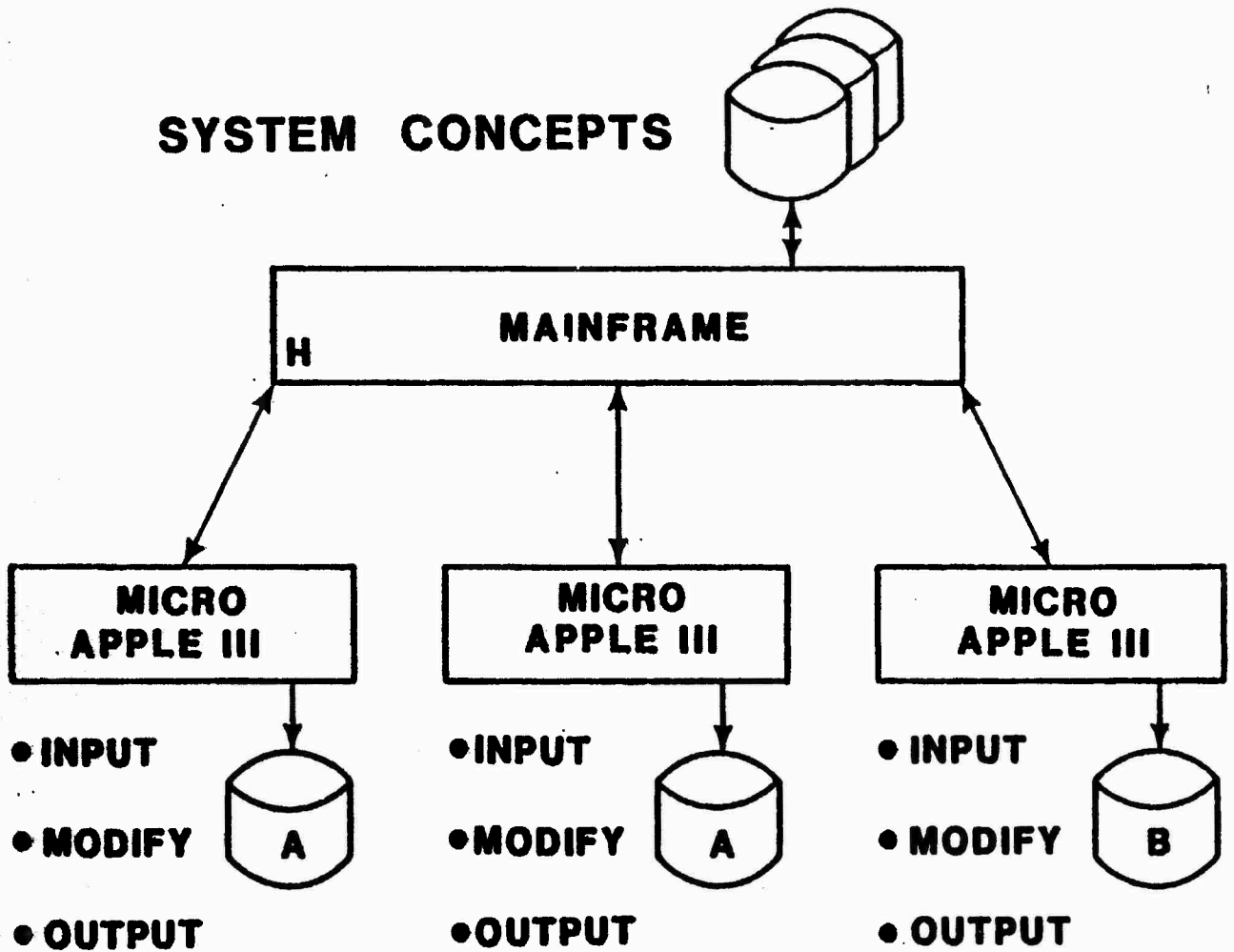

Figure 1-1. SDT Architecture.

APPLE III terminal, or (2) by moving the joystick on a paddle up or down. If the menu contains more items than can fit on a screen, users may use scrolling techniques (again activated by the up/down keys or the joystick) to "run" up or down the menu until the desired item has been located. When users have finished with that item, they can press the return key on the terminal (or the button on the joystick) and another frame of the data will appear on the screen. Dashed lines are used to indicate the maximum width of data input fields. If users attempt to enter characters which are not appropriate for the variable type (alphanumeric, or numeric) the system will refuse to accept this input and will produce an appropriate error message.

o **MODES OF OPERATION**

The SDT has seven major modes of operation:

- o **Audit/Update Trait** - This mode permits users to receive and transmit data to the mainframe and to examine the system audit trail stored on the mainframe.
- o **Input Data** - This mode is used to input data.
- o **Correct Data** - This mode is used when modifications to a small number of data attributes are required.
- o **Output Data** - This mode is used to obtain and create output reports.

- o Save/Restore - This mode is used to copy the SDT data base to a floppy diskette or to copy the data base from a floppy diskette to the micro-computer. The Save/Restore mode permits users to maintain a local copy of the data base.
- o Applications - This mode allows users to select and use the applications programs which use SDT data.
- o Auxiliary - This mode is used to set up an SDT data base and to modify SDT software. This mode is not available to the typical user. (The option for this mode will not appear on the screen unless you have been designated to manage SDT software).

o CHARACTERISTICS OF SDT DATA BASE

Data base management systems such as the SDT use a specialized "language" to describe the relationships among data elements. Unlike many other data base management systems, the SDT does not require the user to explicitly use or even know about this specialized data language. In the SDT, the data language is made "invisible" to the user through "user-friendly" human-computer dialogue techniques such as menu-selection and question-and-answering.

There are four major types of variables in the SDT data language:

- o Entities - Major system elements. Entities are roughly equivalent to nouns in the English language. The entities in the SDT are functional requirements, system missions, equipment, tasks, courses, training media, and personnel.
- o Subentities - Lower level system elements. Subentities are linked to entities in a hierarchical fashion. For example, "task conditions" are subentities of tasks.
- o Attributes - Descriptors that delimit or specify important properties or entities. Each attribute has associated with it a set of values. Attributes are used to describe both entities and subentities. For example, one attribute for the entity task is "task frequency".
- o Pointer Variables - Variables used to specify the relationships which exist between different entities, between entities and subentities, and between entities, subentities, and attributes. The relationships specified by the pointer variables determine the SDT data structure.

#### 1.4 Guidelines for Using this Guide

There are twelve remaining sections in this user guide. Section 2 contains an example application of the SDT. This example is designed to provide first-time users with a "feeling" for the SDT menus and frames. No experience is required to run this exercise. Section 3 describes basic

operational procedures for using the SDT and the hardware/software requirements for using the SDT. Section 4 describes procedures for initially setting up an SDT data base. Sections 5 thru 12 describe the menus and frames in the seven modes of operation (audit/update, input, correct, output, save/restore, applications programs, and auxiliary programs) as well as the initial frames which allow you to select modes. Section 13 contains guidelines for entering data into the SDT. This is an important section since it describes the best sequence for entering data into the SDT. It also describes the relationships between the data elements and specific procedures and worksheets in the ETES User's Guide. The ETES User's Guide describes how to develop the data elements which go into the SDT.

Figure 1-2 provides guidelines for helping the reader select the appropriate section of the SDT user's guide. If you are not familiar with SDT operational procedures you should read Section 3 (Basic Operational Procedures) and Section 14 (Guidelines for Entering Data) before attempting to read any of the other sections or attempting to use the SDT. If you are a first time user and have not seen the SDT in operation, you probably should start by reading and applying the example application in Section 2.

If you are not using an existing data base and want to set up a new data base on the SDT, you should read Section 4 (Setting Up an SDT Data Base) before continuing.

If you are using an existing data base, you must get the data base onto your computer. There are two ways to do this: (1) copy it from the SDT mainframe computer, and (2) copy it from floppy diskettes. Procedures for copying it

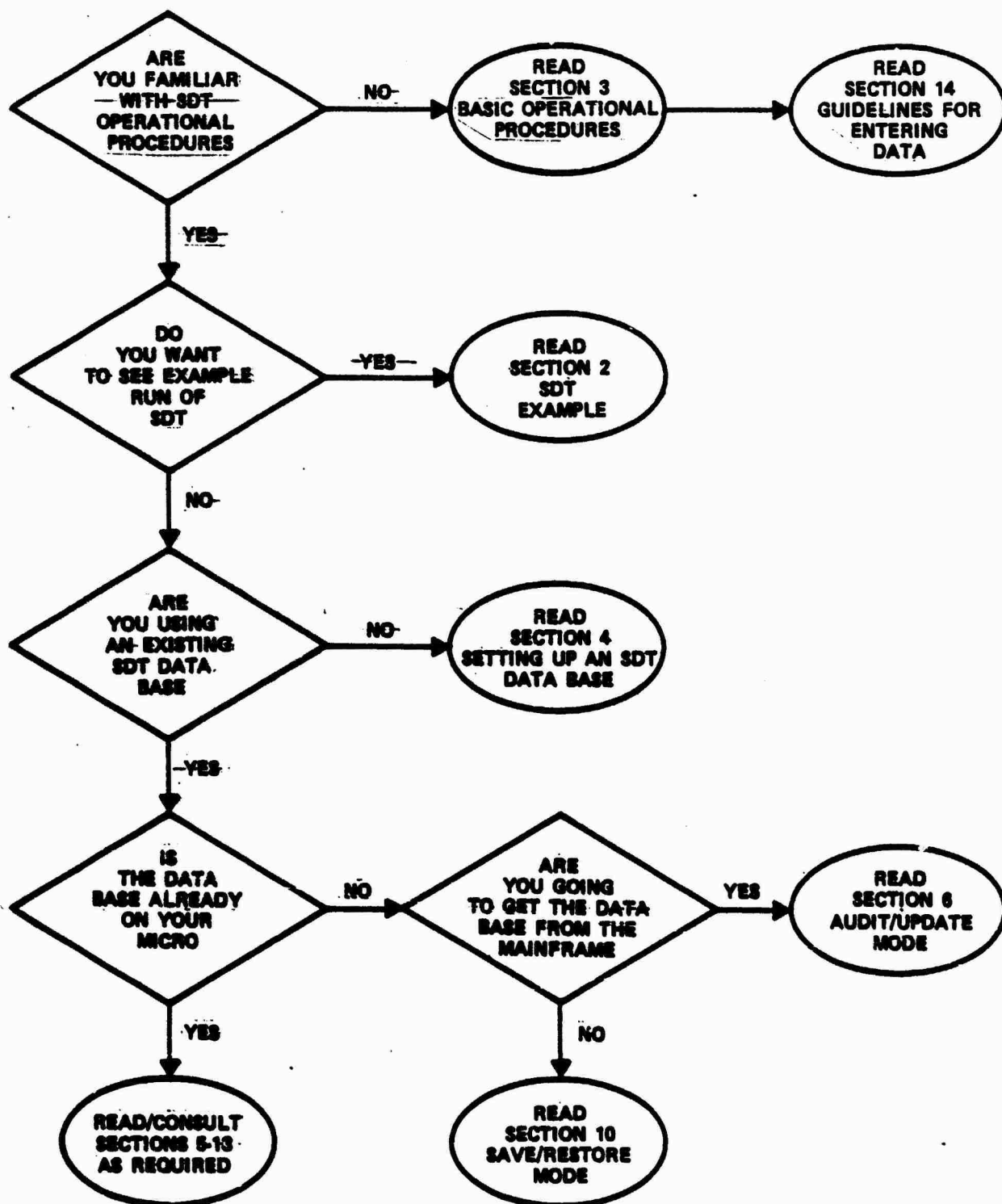

Figure 1-2 Guidelines for Using SDT User's Guide

from a mainframe are described in Section 6 (Audit/Update Mode) and procedures for copying it from a floppy diskette are described in Section 10.

Once you have a data base on your computer and you are familiar with SDT procedures you are ready to use the SDT to input, modify, and output data. However, you will still probably have questions about the SDT menus and frames. Detailed descriptions of these menus and frames are presented in Sections 5 thru 13.

Throughout this guide, actual frames and menus from the SDT will be displayed. Since it is not possible to highlight items in print, items that are highlighted in the SDT menus and frames are underlined in this guide.

**THIS PAGE INTENTIONALLY LEFT BLANK**

## SECTION 2 - SDT EXAMPLE

This section provides detailed step-by-step guidance for running an example application of the SDT. The exercise will allow you to (1) get a description of a hypothetical course which is stored in the example data base, and (2) change the current value of the course's length. The example will allow you to use the Output and Correct modes of the SDT. Before beginning you should read Section 3 (Basic Operational Procedures).

Procedures for running the example are listed in the pages which follow. Each page describes one of the specific actions you must take in an SDT menu or frame. Each page contains a verbal description of the action which you must take along with a listing of the relevant menu or frame.

### Action 1: Insert SDT Boot Diskette

The example data base is contained on your SDT Boot Diskette. You must insert the diskette into the built-in disk drive on your APPLE III. To insert the diskette, open the disk drive and slip the diskette into the slot with the label facing upward as shown in Figure 2-1. Gently push the diskette into the drive and close the door. Turn off your Apple and then turn it on again, using the switch at the back left of the Apple. You will see Apple III SOS copyright information on the screen. After a few seconds, the first SDT frame should appear on the screen. This frame contains the letters "SDT" on the right hand side.

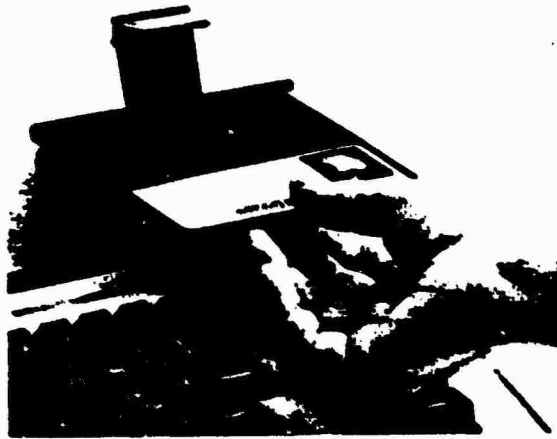

**Figure 2-1. Inserting a Diskette.**

**Action 2: Examine SDT Introduction Frame**

The SDT introductory frame (see Figure 2-2 below) will appear on the screen. The frame will describe instructions for using SDT menus. Read the instructions and use what you have learned to move to the next frame. More specifically, move the cursor up and down until you get to the option Skip to Start of Program, then hit Return.

WELCOME TO THE  
SYSTEM DESCRIPTION TECHNOLOGY  
(SDT)

Whenever the right arrow appears, press the up or down arrow keys on the keyboard or use the joystick until the desired menu action is highlighted. Then press the RETURN key on the keyboard or push the joystick button.

For a further explanation at any time, hold down the escape key (upper left hand corner) or toggle the auxiliary switch on the joystick. The explanation will remain on the screen for as long as the key or button is held down.

More instructions

Skip to start of program

Wait until later time

Figure 2-2. SDT Introduction (SDT-1).

**Action 3: Select System**

A menu will appear on the screen asking you to select the system to be examined. (See Figure 2-3) Move the cursor to SDT Example and hit Return.

## SYSTEM SELECTION

Select system for this session.

- SDT Example
- ARI Example

Figure 2-3. System Selection.

**Action 4: Examine System Description**

A description of the data base created for this example will appear on the screen (Figure 2-4). Read the description, then move the cursor to Continue and hit Return.

System Selected:

SDT EXAMPLE

DESCRIPTION GOES HERE.

UP TO 10 LINES

-ABORT SDT EXAMPLE-  
CONTINUE

Figure 2-4. System Description (SDT-3).

**Action 5: Select SDT Mode of Operation**

A menu will appear on the screen asking you to select one of the seven SDT modes of operation (see Figure 2-5). Move the cursor to Output and hit Return.

## SDT MODE SELECTION

SELECT SDT OPERATION MODE:

-EXIT SDT-	(Terminate the Program)
-AUDIT/UPDATE-	(Examine Audit Trail/Update on Honeywell at DRC)
-INPUT DATA-	(Add Tabular Data into the SDT data files)
-CORRECT DATA-	(Change Specific Attribute for a Particular Entity)
<u>-OUTPUT DATA-</u>	<u>(Display or Print Existing Data)</u>
-SAVE/RESTORE-	(Copy this system to or from diskette)
-APPLICATIONS-	(Execute the Applications Programs)
-AUXILIARY-	(Execute Auxiliary SDT Programs)

Figure 2-5. Mode Select (SDT-4).

**Action 6: Select Output Entity**

A menu will appear on the screen, asking you to select which of the seven SDT entities you want to obtain output for (see Figure 2-6). Move the cursor to Courses and hit Return.

SDT OUTPUT MODE

SELECT ENTITY TO OUTPUT FROM LIST BELOW:

-EXIT SDT-

-EXIT OUTPUT ENTITY MODE-

FUNCTION

EQUIPMENT

TASK

COURSE

MISSION

MEDIA

DUTY POSITION

Figure 2-6. Select Output Entity (0-1).

**Action 7: Select Output Device**

A menu will appear on the screen asking you to indicate where you want your data output (see Figure 2-7). Move the cursor to CRT SCREEN and hit Return.

Select Output Device:

-ABORT-  
-CRT SCREEN-  
-PRINTER-

Figure 2-7. Select Device (0-2).

**Action 8: Select Output Format**

A menu will appear on the screen requesting the selection of an output format (See Figure 2-8). Move the screen to Course Description and hit Return.

Select Output Device:

-ABORT-  
CRT SCREEN  
PRINTER

Select Output Format:

-ABORT-  
-CREATE YOUR OWN-  
COURSE LISTING  
COURSE DESCRIPTION  
COURSE SCENARIO AND RESOURCE INFORMATION  
YEARLY STUDENT INPUTS-LOCATION ONE  
COURSE COSTS - PART 1  
COURSE COSTS - PART 2  
COURSE OUTLINE  
TASKS BY COURSE  
MEDIA BY COURSE MODULE

Figure 2-8. Select Output Format (0-3).

### Action 9: Select Courses

A menu will appear asking you to indicate which of the courses in the data base you would like to obtain data for (see Figure 2-9). Move the cursor to All Courses and hit Return.

Select COURSE(s):

-ABORT-

-SELECT ALL COURSES-

SINGARS OPERATOR

SINGARS MAINTENANCE

M-1 OPERATOR'S COURSE

Figure 2-9. Select Specific Entities (0-9).

**Action 10: Examine Output**

The information contained in the Course Description output report for the two courses in the example data base will appear on the screen (see Figure 2-10). After examining the output, move the cursor to the option Abort Course Output and hit Return.

<u>COURSE DESCRIPTION</u>	
COURSE NUMBER:	042-13M10
TITLE:	SINGARS OPERATOR COURSE
COURSE LENGTH:	16
TYPE:	INDIVIDUAL
ALTERNATIVE:	NORDEN
STATUS:	MODIFIED
COMPARABLE COURSE:	AN/TSQ-38 OPERATOR COURSE
COMPARABLE NUMBER:	068-79V10
<hr/>	
COURSE NUMBER:	078-79J10
TITLE:	SINGARS MAINTENANCE COURSE
COURSE LENGTH:	26
TYPE:	INDIVIDUAL
ALTERNATIVE:	NORDEN
STATUS:	MODIFIED
COMPARABLE COURSE:	AN/TSQ-38 MAINTENANCE COURSE
COMPARABLE NUMBER:	091-23R10

-ABORT COURSE OUTPUT  
~~-CONTINUE-~~

Figure 2-10. Output (0-11).

**Action 11: Exit Output Mode**

You will now return to the menu which allowed you to select entities (for example, courses) for output (see Figure 2-11). Move the cursor to Exit Output Mode and hit Return.

SDT OUTPUT ENTITY MODE

SELECT ENTITY TO OUTPUT FROM LIST BELOW:

-EXIT SDT-

-EXIT OUTPUT ENTITY MODE

FUNCTION

EQUIPMENT

TASK

COURSE

MISSION

MEDIA

DUTY POSITION

Figure 2-11. Select Entity to be Output (0-1).

**Action 12: Select Correct Mode**

You are now at the menu which allows you to select SDT modes of operation (see Figure 2-12). Move the cursor to Select Correct Mode and hit Return.

This mode will allow you to change the attributes of the courses you examined in the Output Mode.

SDT MODE SELECTION

SELECT SDT OPERATION MODE:

-EXIT SDT-	(Terminate the Program)
-AUDIT/UPDATE-	(Examine Audit Trail/Update on Honeywell at DRC)
-INPUT DATA-	(Add Tabular Data into the SDT data files)
<u>-CORRECT DATA-</u>	<u>(Change Specific Attribute for a Particular Entity)</u>
-OUTPUT DATA-	(Display or Print Existing data)
-SAVE/RESTORE-	(Copy this system to or from diskette)
-APPLICATIONS-	(Execute the Applications Programs)
-AUXILIARY-	(Execute Auxiliary SDT Programs)

Figure 2-12. SDT Mode (SDT-4).

**Action 13: Select Course Entity**

You are now at the menu which allows you to select which of the seven SDT entities to correct (see figure 2-13). Move the cursor to Courses and hit Return.

SDT CORRECT ENTITY MODE

SELECT ENTITY TO CORRECT FROM LIST BELOW:

-EXIT SDT-  
EXIT CORRECT ENTITY MODE  
FUNCTION  
EQUIPMENT  
TASK  
COURSE  
MISSION  
MEDIA  
DUTY POSITION

Figure 2-13. Select Correct Entity (C-1).

**Action 14: Select Course**

A menu will come on the screen asking you to indicate which of the courses currently in the data base you would like to correct (see Figure 2-14). Move the screen to the first course on the list and hit Return.

Select COURSE(s):

-ABORT-

-SELECT ALL COURSES-

SINGARS OPERATOR

SINGARS MAINTENANCE

M-1 OPERATOR'S COURSE

Figure 2-14. Select Specific Entities (C2)

Action 15: Select Attribute to Correct

A menu will come on the screen asking you to indicate which of the course attributes you would like to modify (see Figure 2-15). Move the cursor to Course Length and hit Return.

Select First COURSE Attribute:

-ABORT-

TITLE

COURSE NUMBER

COURSE LENGTH

TYPE

ALTERNATIVE

STATUS

COMPARABLE COURSE

COMPARABLE NUMBER

PREREQUISITE COURSES

FOLLOW-ON COURSES

ATTRITION RATE

MAXIMUM CLASS SIZE

CLASS FREQUENCY

RESOURCE REQUIREMENTS

COURSE COSTS

(more)

Figure 2-15. Select Attribute (C-3).

**Action 16: Modify Course Length**

The old value of course length will appear on the screen and you will be asked to indicate whether you would like to change it or leave it (see Figure 2-16). Move the cursor to Change It and hit Return. Type in a new value for the course length in the space provided and hit Return.

SINGARS OPERATOR COURSE

Enter COURSE LENGTH:

-----

-----

THEN PRESS RETURN

(MAKE NO ENTRY TO ABORT)

Figure 2-16. Modify Course Attribute (C-4).

**Action 17: Exit Correct Mode**

You are now ready to exit the correct mode and obtain a new output report so you can examine the data you have just modified. To do this you will use menus you have used before. The actions you must take in these menus are listed below.

- o Select No More Attributes on Course Attribute Menu
- o Select Exit Output Mode on Output Entity Select Menu
- o Reapply actions 5-9

## SECTION 3 - SDT OPERATIONAL PROCEDURES

This section describes basic operational procedures for using the SDT. In addition, it describes the hardware/software required to use the SDT.

This section is divided into five subsections. Section 3.1 describes the hardware required to use the SDT. Section 3.2 describes the software required to use the SDT. Section 3.3 describes procedures for using the SDT menus. Section 3.4 describes procedures for automatically obtaining definitions for each SDT command or data element. Section 3.5 describes how the built-in SDT output reports can be used to assist to the data base development process.

### 3.1 SDT Hardware

To use the SDT, you must have an Apple III computer with:

- o 128K Bytes of RAM memory.
- o A video monitor. The monitor can be black and white or color. However, the program does not produce color images.
- o A 5 megabyte Profile hard disk.
- o An additional floppy disk drive (that is, over and above the disk drive built into your Apple III).

This drive is needed to make a local floppy disk copy of your data base and to load the SDT program.

- o A printer. A printer is needed to get hard copy output.

In addition, you may also want to obtain a joystick with pushbuttons. This joystick can be used to move items about the SDT menus and to select menu items. This item is clearly optional since its major function is to make the menu selection process easier to use.

If you are using the Apple for the first time, be sure to follow the Apple III Owner's Guide for instructions on how to connect the computer, the monitor, and an extra floppy disk drive. Also, follow the manufacturer's instructions on how to connect your PROFILE hard disk to your system.

Figure 3-1 shows the APPLE III keyboard. Please note the location of the ESCAPE key. This key is especially important since hitting it will allow to obtain a definition of SDT commands and data elements (see Section 3.2).

### 3.2 SDT Software Requirements

To use the full capabilities of the SDT, you will need the following software:

- o SDT Program Diskettes. The program diskettes contain the SDT program software.

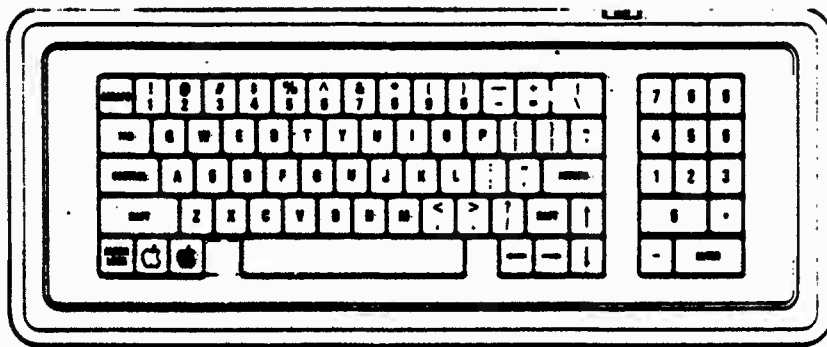

Figure 3-1. The Apple III Keyboard.

- o SDT Boot Diskette - This diskette is used to boot (that is, activate) the SDT software.
  
- o SDT Backup Diskettes - These backup diskettes are used to make a local copy of the data base. You may not use all of the diskettes if you have a small data base. If you are going to be working with more than one data base, you will need a set of Backup diskettes for each data base.<sup>1</sup>

### 3.2.1 General Instructions for Handling Diskettes

To insert a diskette, open the disk drive and slip the diskette into the slot with the label facing upward as shown in Figure 3-2. The edge of the diskette with the oval cutout should enter the drive first; the edge with the label should enter face up and last. Gently push the diskette into the drive; do not bend it. Close the drive door firmly.

To remove the diskette, open the door and pull the diskette straight out of the slot. If you leave the diskette in a drive for long periods of time without use, it is a good idea to open the door so the read/write head does not rest on the diskette.

---

<sup>1</sup> For information on obtaining SDT software, contact Dr. Lawrence H. O'Brien, Dynamics Research Corporation, 7 Lopez Road, Wilmington, MA 01887.

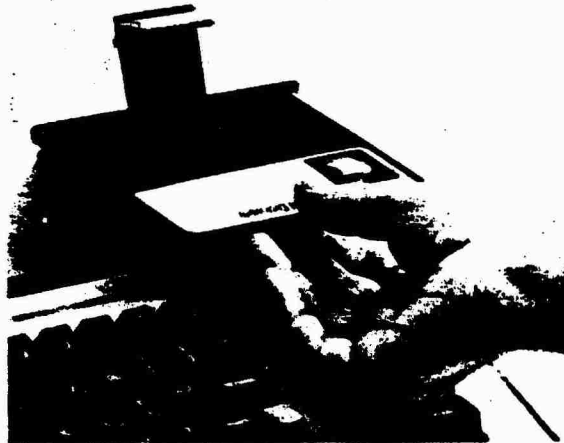

**Figure 3-2. Inserting a Diskette.**

NEVER REMOVE A DISKETTE WHILE THE RED LIGHT UNDER THE DOOR IS ON. This can permanently damage the diskette and is almost certain to destroy the information on it. You may be able to reuse such a diskette, but you will not be able to recover the lost data.

### 3.2.2 Loading SDT Program Software

The program which contains the SDT software should be stored on your PROFILE hard disk.

To load the SDT program into your hard disk use the following procedures:

- o Load the SDT Boot Disk into the built-in drive. Turn the computer off and then on again using the switch at back left of the Apple.
- o Follow the instructions which appear on the screen, and load the SDT Program Diskettes into the additional floppy disk drive.

Once the SDT Program Diskettes have been loaded onto your PROFILE hard disk, you will not have to enter the SDT Program Diskettes again.

### 3.2.3 Procedures for Making a Floppy Disk Copy of Your Data Base

Procedures for making a floppy disk copy of your data base are described in Section 9.

### 3.3 Using SDT Menus

The SDT options are listed in menus. SDT menus list a set of items from which you may choose. A typical menu is shown in Figure 3-3.

To select a menu option, you must highlight it with the cursor and press the RETURN key. The cursor is a highlighted area on the screen, as shown in Figure 3-3.

You can move the cursor in one of two ways. You can use the arrow keys or use a joystick. You actually select a highlighted option when you press the RETURN key (or hit the button on the joystick).

Moving the cursor to a menu option causes no action to take place. To select a menu option, you must move the cursor to the option and press the RETURN key.

Some menus in the SDT may have so many items that not all of these items will be able to be shown at the screen at any one time (such menus will have the phrase MORE at the bottom). To see these additional items, you must scroll the menu up or down. To scroll down, move to the bottom of the menu by hitting the down arrow key. Continue to hit this key and the menu will move up showing you the additional

SDT MODE SELECTION

SELECT SDT OPERATION MODE:

-EXIT SDT-	(Terminate the Program)
-AUDIT/UPDATE-	(Examine Audit Trail/Update on Honeywell at DRC)
-INPUT DATA-	(Add Tabular Data into the SDT data files)
-CORRECT DATA-	(Change Specific Attribute for a Particular Entity)
<u>-OUTPUT DATA-</u>	<u>(Display or Print Existing Data)</u>
-SAVE/RESTORE-	(Copy this system to or from diskette)
-APPLICATIONS-	(Execute the Applications Programs)
-AUXILIARY-	(Execute Auxiliary SDT Programs)

Figure 3-3. Typical SDT Menu

items in the menu. You can then scroll back up by hitting the up arrow key.

### 3.4 SDT Help Aids

You can obtain a definition for any command or for any SDT data element by pressing the ESCAPE key when the cursor is on the item associated with the command or data element. The definition will appear on the bottom portion of the screen and will stay on as long as you hold down the ESCAPE key (see Figure 3-4).

### 3.5 SDT Output Reports

The SDT allows you to either (1) use a standard set of output formats or (2) create your own output formats (see Section 7- Output Mode). A list of the standard formats on the SDT is provided in Table 3-1. A more detailed description of these output formats is provided in Appendix B.

The formats you create will be stored in the SDT so that you can use them in future uses of the SDT. Both the standard formats and the formats you create can be used to assist you in inputting data. More specifically, the input mode has an option which allows you to select one of the output formats, thereby avoiding the somewhat tedious process of having to select the attributes you want to enter.

WELCOME TO THE  
SYSTEM DESCRIPTION TECHNOLOGY  
(SDT)

Whenever the right arrow appears, press the up or down arrow keys on the keyboard or use the joystick until the desired menu action is highlighted. Then press the RETURN key on the keyboard or push the joystick button.

For a further explanation at any time, hold down the escape key (upper left hand corner) or toggle the auxiliary switch on the joystick. The explanation will remain on the screen for as long as the key or button is held down.

More instructions

Skip to start of program

Wait until later time

Every time you press the escape key (or the alternate switch on the same controller), this bottom portion of the screen will further explain the option which is currently highlighted. For instance, right now the option highlighted is "Skip to start of program". If selected, the program will begin without further instructions.

Figure 3-4. SDT Help Aids

Table 3-1. Standard SDT Output Formats.

REPORT	DATA ELEMENTS	TOTAL COLUMN WIDTH
<u>FUNCTIONS</u>		
• SIMPLE FUNCTION LISTING	FUNCTION NUMBER, FUNCTION NAME	80
• COLLECTIVE TASKS BY FUNCTION	FUNCTION NUMBER, FUNCTION NAME, COLLECTIVE TASK NAME	80
• FUNCTION SEQUENCE	FUNCTION NUMBER, FUNCTION NAME, PRECEDING FUNCTION, SUCCEEDING FUNCTION	80
• TASKS BY FUNCTION	FUNCTION NUMBER, FUNCTION NAME, TASK NAME, TASK NUMBER	80
• EQUIPMENTS BY FUNCTION	FUNCTION NUMBER, FUNCTION NAME, EQUIPMENT #, EQUIPMENT NAME	80
• FUNCTION PERFORMANCE GOALS	FUNCTION NUMBER, FUNCTION NAME, PERFORMING MEASURE, GOAL/STANDARD	80
• ENVIRONMENTAL IMPACTS	FUNCTION NUMBER, FUNCTION NAME, ENVIRONMENTAL VARIABLE, VARIABLE IMPACTED, REFERENCE	80
• THREAT IMPACT	FUNCTION NUMBER, FUNCTION NAME, THREAT VARIABLE, VARIABLE IMPACTED, REFERENCE	80
• MISSION IMPACTS ON FUNCTIONS	FUNCTION NUMBER, FUNCTION NAME, MISSION IMPACT VARIABLE, VARIABLE IMPACTED, REFERENCE	80
<u>EQUIPMENTS</u>		
• SIMPLE EQUIPMENT LISTING	EQUIPMENT NUMBER, EQUIPMENT NAME	80
• TASKS BY EQUIPMENT	EQUIPMENT NUMBER, EQUIPMENT NAME, TASK NUMBER, TASK NAME	80
• EQUIPMENT RELIABILITY DATA	EQUIPMENT NUMBER, EQUIPMENT NAME, MTBF, MTTR, MTBMA	80
• NUMBER OF ITEMS SUPPORTED	EQUIPMENT NUMBER, EQUIPMENT NAME, # CREW, # ORGANIZATIONAL, # DS, # DEPOT	80
• COMPARABLE EQUIPMENT BY EQUIPMENT	EQUIPMENT NUMBER, EQUIPMENT NAME, COMPARABLE EQUIPMENT, AMOUNT OF DIFFERENCE	80
• GENERIC EQUIPMENT LISTING	EQUIPMENT NUMBER, GENERIC EQUIPMENT, EXISTING EQUIPMENT	80
• INFORMATION INPUTS AND OUTPUTS	EQUIPMENT NUMBER, EQUIPMENT NAME, INFORMATION INPUT, INPUT SOURCE, INFORMATION OUTPUT, OUTPUT SOURCE	80
• EQUIPMENT COSTS	EQUIPMENT NUMBER, EQUIPMENT NAME, R&D COST, INVEST. COST, O&S COST, UNIT PRICE, CAT 5 COST, CAT 6 COST, CAT 7 COST, CAT 8 COST, CAT 9 COST	80
• SIMPLE TASK LISTING	TASK NUMBER, TASK NAME	80
• TASK ELEMENTS	TASK NUMBER, TASK NAME, TASK ELEMENT NAME	80
• TASK CONDITIONS AND STANDARDS	TASK NUMBER, TASK NAME, TASK CONDITIONS, TASK STANDARDS, AMOUNT VALUE	80
• EXTENDED TASK DESCRIPTION	TASK NAME, TASK TYPE, TASK STATUS, WORK AREA, TASK AREA, AMOUNT OF SUPERVISION, NUMBER OF PERFORMING	80

COLUMN WIDTH	DATA ELEMENTS	REPORT
80	TASK NUMBER, TASK NAME, PRECEDING TASK, SUCCEEDING TASK	EQUIPMENTS (continued)
80	TASK NUMBER, TASK NAME, INITIATING CUE, AND ASSOCIATED EQUIPMENT, TERMINATING CUE AND ASSOCIATED EQUIPMENT	• TASK SEQUENCE INFORMATION
80	TASK NUMBER, TASK NAME, FAILURE, & OF FAILURES	• INITIATING AND TERMINATING CUES
80	TASK NUMBER, TASK NAME, TOOLS/TEST EQUIPMENT, NUMBER, TYPE	• FAILURE MODES
80	TASK NUMBER, TASK NAME, SKILL/KNOWLEDGE, TYPE, CATEGORY, SKILL AND KNOWLEDGE CHARACTERISTIC ONE, SKILL AND KNOWLEDGE CHARACTERISTIC TWO	• TOOLS AND TEST EQUIPMENT
80	TASK NUMBER, TASK NAME, LEARNING OBJECTIVE CHARACTERISTICS ONE AND TWO	• SKILLS AND KNOWLEDGES
80	TASK NUMBER, TASK NAME, PERFORMANCE MEASURE, AMOUNT/VALUE	• LEARNING OBJECTIVES
80	TASK NUMBER, TASK NAME, & PERFORMING, & TIME, CONSEQUENCES OF INADEQUATE, TASK DELAY TOLERANCE, LEARNING DIFFICULTY, FREQUENCY OF PERFORMANCE, TIME BETWEEN ENTRY AND PERFORMANCE	• PERFORMANCE MEASURES
80	TASK NUMBER, TASK NAME, STIMULUS VARIABLES FROM ETES MEDIA SELECTION PROGRAM	• TRAINING EMPHASIS RATINGS
80	TASK NUMBER, TASK NAME, RESPONSE VARIABLES, ETES MEDIA SELECTION PROGRAM	• STIMULI - (PARTS 1 AND 2)
80	TASK NUMBER, TASK NAME, FEEDBACK VARIABLES FROM ETES MEDIA SELECTION PROGRAM	• RESPONSES
80	COURSE NUMBER, COURSE TITLE	• FEEDBACK
80	COURSE NUMBER, COURSE TITLE, COURSE LENGTH, COURSE TYPE, ALTERNATIVE, STATUS, COMPARABLE COURSE, COMPARABLE COURSE NUMBER	COURSES
80	COURSE NUMBER, COURSE TITLE, COURSE LENGTH, ATTRITION RATE, CLASS SIZE, FREQUENCY, NUMBER OF NORM GRADS, QUARTERS/MESS AVAILABLE, PER CENT OFFICERS, PER CENT TDY, INSTRUCTOR CONTACT HOURS PER CLASS, NUMBER OF INSTRUCTIONS, P8 REQUIREMENTS	• COURSE LISTING
80	COURSE NUMBER, COURSE TITLE, COURSE LENGTH, LOCATION, YSI-YEAR 1, YSI-YEAR 2, YSI-YEAR 3, YSI-YEAR-4, YSI-YEAR 5, YSI-STEADY STATE	• COURSE DESCRIPTION
80	COURSE NUMBER, COURSE TITLE, 23 COST VARIABLES	• COURSE SCENARIO AND RESOURCE INFORMATION
80	COURSE NUMBER, COURSE TITLE, MODULE TITLE, METHODS WITHIN MODULES, CONTACTS HOURS PER METHOD, STUDENT/INSTRUCTOR RATIO PER METHOD	• YEARLY STUDENT INPUTS (YSI)
80	COURSE NUMBER, COURSE TITLE, MODULE TITLE, TASKS	• COURSE COSTS
80		• QUASI-POI: PART 1
80		• QUASI-POI: PART 2

Table 3-1. Standard SDT Output Formats. (continued)

REPORT	DATA ELEMENTS	TOTAL COLUMN WIDTH
<u>COURSES</u> (continued)		
• MEDIA BY COURSE	COURSE NUMBER, COURSE TITLE, MODULE TITLE, MEDIA	80
<u>MISSIONS</u>		
• MISSION PROFILE	MISSION NAME, ANNUAL NUMBER OF MISSIONS, ANNUAL OPERATING DAYS, MEAN DURATION, ANNUAL OPERATING DAY REQUIREMENTS	80
<u>MEDIA</u>		
• MEDIA DESCRIPTION	MEDIA TITLE, ALTERNATIVE, MEDIA NUMBER, ISSUE RATE PER STUDENT, PUBLICATION DATE, REVISION DATE, MEDIA TYPE-GENERAL, MEDIA TYPE-SPECIFIC, MAXIMUM DAILY OPERATING TIME, STUDENT INSTRUCTOR RATIO, INDEX OF EFFECTIVENESS, OVERALL INDEX OF EFFECTIVENESS, INDEX OF PERSONNEL REQUIREMENTS	80
• MEDIA COSTS	MEDIA NAME, 12 COST VARIABLES	80
• NUMBER OF MEDIA	MEDIA NAME, NUMBER IN YEARS ONE THROUGH SEVEN AND STEADY STATE	80
• DUTY POSITION DESCRIPTIONS	DUTY POSITION TITLE, DUTY POSITION NUMBER, MOS TITLE, MOS NUMBER, ASI TITLE, ASI NUMBER, SKILL LEVEL	80
• MANPOWER REQUIREMENTS	DUTY POSITION TITLE, MOS NUMBER, ASI NUMBER, START DATE, MANPOWER REQUIREMENTS IN YEARS ONE THROUGH SEVEN	80
• TASKS BY DUTY POSITION	DUTY POSITION TITLE, MOS NUMBER, ASI NUMBER, TASK NUMBER, TASK TITLE	80
• ORGANIZATIONAL REQUIREMENTS	DUTY POSITION TITLE, MOS NUMBER, ASI NUMBER, NUMBERS AND TITLES FOUR LEVELS OF ORGANIZATION	80

**THIS PAGE INTENTIONALLY LEFT BLANK**

Table 4-1. Worksheet for Setting Up SDT Data Base.

PART 1 - DATA BASE SIZE

DATA ELEMENT	ESTIMATE OF TOTAL NUMBER REQUIRED
<b>FUNCTIONS</b>	
- PERFORMANCE GOALS	
- ENVIRONMENTAL IMPACTS	
- THREAT IMPACTS	
- MISSION IMPACTS	
<b>EQUIPMENTS</b>	
- SOFTWARE REQ. DESCRIPTIONS	
- INFORMATION INPUTS	
- INFORMATION OUTPUTS	
<b>TASKS</b>	
- TASK ELEMENTS	
- TASK CONDITIONS	
- TASK STANDARDS	
- INITIATING CUES	
- TERMINATING CUES	
- TOOLS/TEST EQUIPMENTS	
- FAILURE MODES	
- SKILLS AND KNOWLEDGES	
- LEARNING OBJECTIVES	
- PERFORMANCE MEASURES	
<b>MISSIONS</b>	
<b>COURSES</b>	
- MODULES	
<b>MEDIA</b>	
<b>DUTY POSITIONS</b>	

## SECTION 4 - SETTING UP AN SDT BASE

There are three steps involved in setting up a new SDT data base. The first step is to fill out a worksheet describing the following information:

- (a) the maximum number of entities and subentities that will be entered into the data base (see Table 4-1).
- (b) the users who will be using the data base and the modes of operation (audit update, input, correct, output, save/restore, applications, auxiliary programs) that each user can employ (see Table 4-1).
- (c) the output devices that each user will employ

Once completed, this worksheet should be sent to the SDT software management group along with a copy of the Driver File for each device on which output will be obtained. The Driver File is needed to set up the interface between the SDT and the output devices.<sup>1</sup>

---

<sup>1</sup> To obtain information on the SDT software management group, contact Dr. Lawrence O'Brien, Dynamics Research Corporation, 7 Lopez Road, Wilmington, MA 01887.



**PART 3 - OUTPUT DEVICES**

User \_\_\_\_\_

COMPUTER	DEVICE-A	DEVICE-B	DEVICE-C	DEVICE-D	DEVICE-E
1					
2					
3					
4					
5					
6					
7					
8					
9					
10					

**NOTE: THE DRIVER FILE FOR EACH DEVICE MUST ACCOMPANY THIS REPORT.**

As outlined in the procedures listed in ETES User Guide, you should set up at least two data bases for each weapon system you are dealing with: one data base describing the Baseline Comparison System (BCS) and another data base describing the New System. You may also want to set up a third data base for the Predecessor system.

If there are entities or attributes which are not currently in the SDT data base which you would like to work with, you should include these on separate sheet of paper. It is relatively easy to add additional entities or attributes to the SDT to meet the special needs of individual users.

Once your worksheet and request have been reviewed and approved, the SDT software management group will then send you and the users you have designated the SDT software needed for your data bases (This software is described in Section 3.2). This software should be loaded into your computer using the procedures listed in Section 3.2.

**THIS PAGE INTENTIONALLY LEFT BLANK**

## SECTION 5 - INITIAL SDT MENUS AND FRAMES

This section describes the initial menus and frames at the beginning of the SDT program. These frames allow you to (1) select a system (that is, a data base) and (2) select which of the seven modes of the SDT you will employ.

There are four of these initial frames:

- o SDT-1 SDT Introduction. This is the first frame you will see. It describes how to select items from an SDT menu.
- o SDT-2 Select System. This frame allows you to select the system or data base on which you would like to work.
- o SDT-3 System Selected. This frame will provide a description of the system you selected.
- o SDT-4 Mode Select. The menu will allow you to select one of the seven major modes of operation in the SDT. These modes are (1) audit/update, (2) input, (3) correct, (4) output, (5) save/restore, (6) applications software, and (7) auxiliary software.

An overview of the logic underlying these initial frames is displayed in Figure 5-1. A more detailed description of

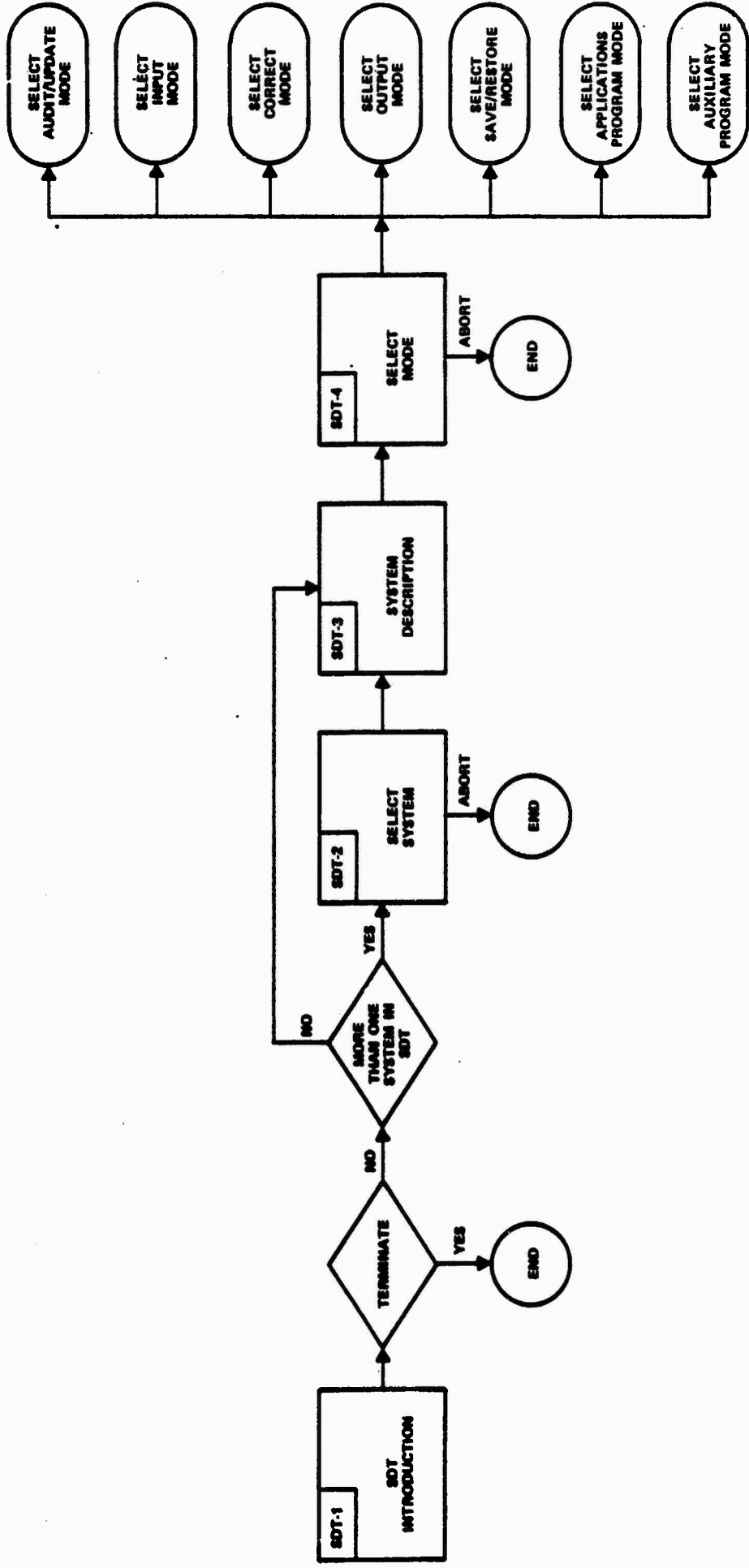

Figure 5-1 Overview of Logic of Initial SDT Frames

these menus and frames is provided in the sections which follow.

WELCOME TO THE  
SYSTEM DESCRIPTION TECHNOLOGY  
(SDT)

Whenever the right arrow appears, press the up or down arrow keys on the keyboard or use the joystick until the desired new action is highlighted. Then press the RETURN key on the keyboard or push the joystick button.

For a further explanation at any time, hold down the escape key (upper left hand corner) or toggle the auxiliary switch on the joystick. The explanation will remain on the screen for as long as the key or button is held down.

More instructions.

Skip to start of program

Wait until later time

Figure 5-2. SDT Introduction (SDT-1).

## 5.2 Description Select System (SDT-2)

This menu allows you to select which system or data base on the SDT you would like to work. An example of this menu is displayed in Figure 5-3. To select a system, move the cursor to the desired item and hit RETURN.

### Abort Options

Exit SDT - By selecting this option you will terminate your session on the SDT.

### Follow-On Frames

System Description (SDT-3)

SYSTEM SELECTION

Select System For this Session

-SDT EXAMPLE-

-ARI EXAMPLE-

Figure 5-3. Select System (SDT-2).

### 5.3 System Description (SDT-3)

#### Description

During this frame, a description of the system you have selected will appear on the screen (you can change this description by entering the correct mode). Up to ten lines of text may be used to describe the system. An example of this frame is presented in Figure 5-4. When you have completed your examination of the system, hit Return.

#### Abort Options

None

#### Follow-On Frames

Mode Select (SDT-4)

System Selected:

SDT EXAMPLE

DESCRIPTION GOES HERE.

UP TO 10 LINES

PRESS RETURN TO CONTINUE

Table 5-4. System Description (SDT-3).

## 5.4 SDT Mode Select (SDT-4)

### Description

This frame allows you to select one of the seven SDT modes. The seven modes are:

- o Audit/Update - Use this mode to transmit a data base to or from the mainframe or to examine the system audit trail.
- o Input - Use this mode to input data or modify large amounts of data.
- o Correct - Use this mode to modify small amounts of data (for example, specific attributes of specific entities).
- o Output - Use this mode to output data.
- o Save/Restore - Use this mode to make a copy of a data base on a floppy diskette or to copy a data base from a diskette to your microcomputer.
- o Applications Program - Use this mode to select and run an ETES applications program (Currently, there is only one such program, Media Selection/Efficiency Estimation).
- o Auxiliary Program - This mode is used to set-up a data base configuration or to change SDT software. Unless you are the data base director, you cannot use this option and it will not appear on this screen.

## SDT MODE SELECTION

SELECT SDT OPERATION MODE:

-EXIT SDT-	(Terminate the Program)
-AUDIT/UPDATE-	(Examine Audit Trail/Update on Honeywell at DRC)
-INPUT DATA-	(Add Tabular Data into the SDT data files)
-CORRECT DATA-	(Change Specific Attribute for a Particular Entity)
-OUTPUT DATA-	(Display or Print Existing data)
-SAVE/RESTORE-	(Copy this system to or from diskette)
-APPLICATIONS-	(Execute the Applications Programs)
-AUXILIARY-	(Execute Auxiliary SDT Programs)

Figure 5-5. SDT Mode Select (SDT-4).

### Abort Options

Exit SDT - By selecting this option, you can terminate your session on the SDT.

### Follow-On Frames

- o Select Audit/Update Option (AV-1)
- o Select Entity To be Input (I-1)
- o Select Entity To be Corrected (C-1)
- o Select Output Entity (O-1)
- o Select Save/Restore Option (RS-1)
- o Select Applications Programs (AP-1)
- o Select Auxiliary Programs (AUX-1)

- o AU-5 - Select Audit Trail Items. This menu allows you to select which specific audit trail entries you would like to examine.
- o AU-6 - Item Description. During this frame a description of the selected audit trail entry will appear on the screen.
- o AU-7 - Select Entity. This menu lets you limit your audit trail examination to the entries involving one SDT entity.
- o AU-8 - Enter Audit Trail Description. This frame allows you to enter an audit trail description of each upload to the mainframe.

An overview of the logic underlying the Audit/Update mode is contained in Figure 6-1. A more detailed description of the menus and frames in this mode is presented in the sections which follow.

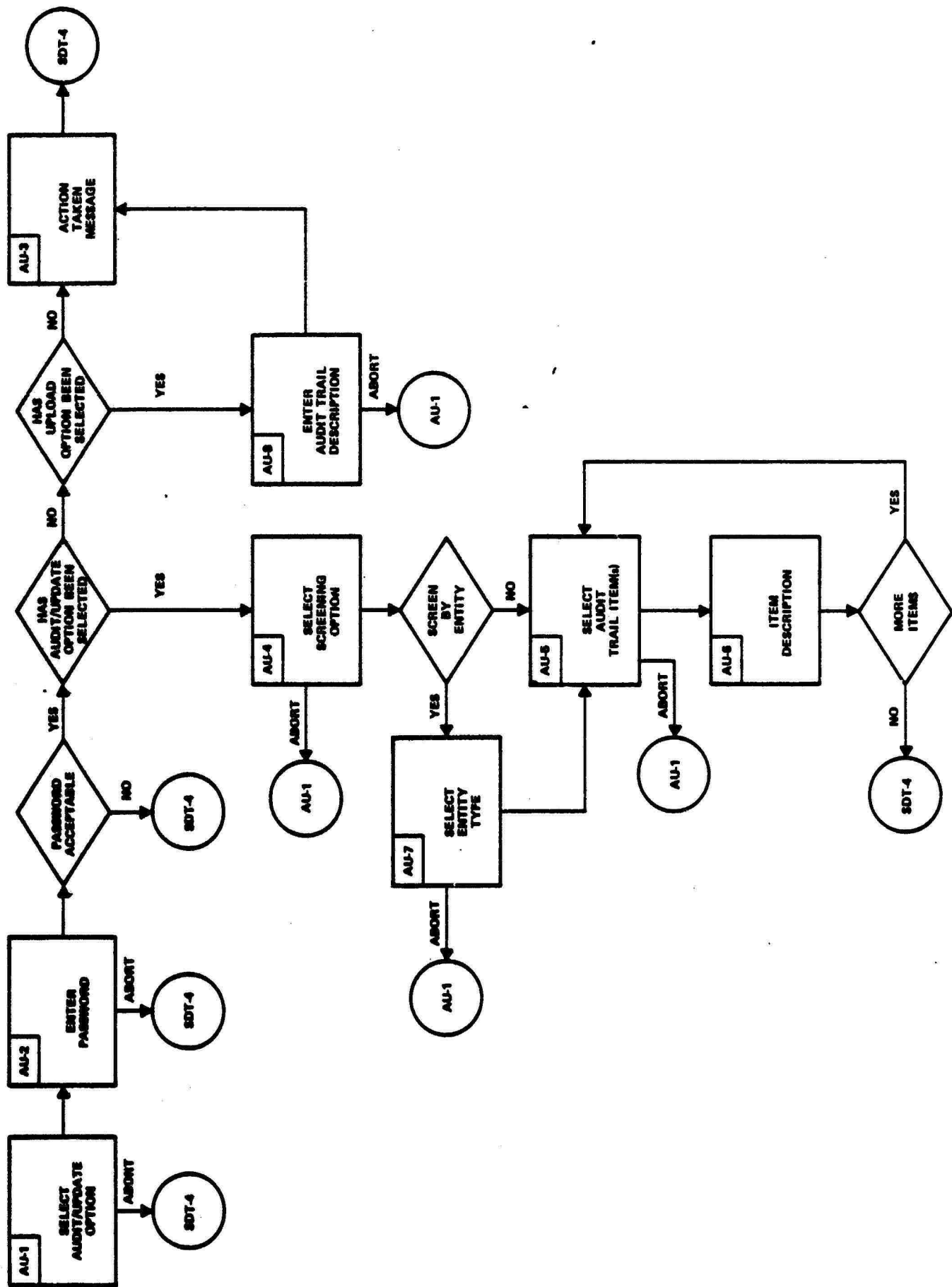

Figure 6-1. Overview of Audit/Update Mode Logic.

## 6.1 Select Audit/Update Option (AU-1)

### Description

This menu allows you to select from one of four options: (1) examine the audit trail, (2) download a data base from the mainframe to the Apple, (3) upload a data base from the Apple to the mainframe, or (4) reserve the main data base on the mainframe. By selecting the reserve option you will prohibit other users from changing the centralized data base on the mainframe for 2 hours. Thus, you can be assured that the data base you have changed and wish to modify is the latest data base. You must select the reserve option before you can select the upload option.

An overview of this frame is presented in Figure 6-2. To select an option, move the cursor to the desired option and hit Return.

### Abort Options

Exit SDT - by selecting this option, you will terminate your session.

Exit Audit Update Mode - By selecting this option, you will return to Mode Select (SDT-4).

### Follow-On Frames

Enter Password (AU-2).

SDT AUDIT/UPDATE MODE

Select AUDIT/UPDATE Option:

- ABORT- (Return to SDT Mode Selection)
- AUDIT TRAIL- (Examine Audit Trail of this System)
- DOWNLOAD- (Update your files from the Honeywell Master Files)
- RESERVE- (Disallow other users to update Master Files)
- UPLOAD- (Update the Honeywell Master files from your files)

Figure 6-2. Select Audit/Update (AU-1).

## 6.2 Enter Password (AU-2)

### Description

During this frame, you must enter your password for using the mainframe computer. To obtain a password, contact your Data Base Director (see Section 3.2).

An example of this frame is provided in Figure 6.3. To enter your password, type in the password characters in the spaces provided and hit Return. If you make an error before hitting Return, you can correct it by backspacing the cursor (by hitting the left arrow key) and retyping the password.

### Abort Options

If you make no entry, you will return to Select Audit/Update (AU-1).

If you enter an erroneous password, you will go the SDT Mode Select (SDT-4).

### Follow-On Frames

If you selected the audit/update option you will go to Select Screening Option (AU-4).

If you selected the upload option, you will go to Enter Audit Trail Description (AU-8).

If you did not select the audit/update or upload options, you will go to Action Taken Message (AU-3).

SDT AUDIT/UPDATE MODE

Select AUDIT/UPDATE Option:

- ABORT- (Return to SDT Mode Selection)
- AUDIT TRAIL- (Examine the Audit Trail of this System)
- DOWNLOAD- (Update your files from the Honeywell Master File)
- RESERVE- (Disallow other users to update Master Files)
- UPLOAD- (Update the Honeywell Master files from your files)

Enter Access Password

-----

-----

THEN PRESS RETURN

(MAKE NO ENTRY TO ABORT)

Figure 6-3. Enter Password (AU-2).

### 6.3 Action Completed Message (AU-3)

#### Description

During actual upload, download, or reserve, a message, (for example, Uploading), will appear on the screen indicating that the action is underway. Once the action has been completed, you will get another message (for example, Upload Completed) indicating that your action has been completed. An example of this frame is presented in Figure 6-4.

#### Abort Options

None

#### Follow-On Frames

If you have selected the reserve option, you will return to Select Audit/Update Option (AU-1).

If you have not selected the reserve option, you will return to Mode Select (SDT-4).

SDT AUDIT UPDATE MODE

UPLOAD COMPLETED

Figure 6-4. Action Taken Message (AU-3)

## 6.4 Select Screening Option (O-3)

### Description

This menu will allow you to select from two options for conducting your audit trail analysis: (1) examine all entries or (2) examine the audit trail items for selected entities or subentities (see Figure 6-5). To select an option, move the cursor to the appropriate item and hit Return.

### Abort Options

Select Audit/Update Option (AU-1).

### Follow-On Frames

If you select the all entries option, you will go to Select Audit Trail Items (AU-5).

If you select the option allowing you to examine entities by entity or subentity you will go to Select Entity Type (AU-7).

SDT AUDIT/UPDATE MODE

Select Screening Option:

-ABORT-

-EXAMPLE ALL ENTRIES-

-SELECTIVELY SCREEN BY ENTITY-

Figure 6-5. Select Screening Option (AU-4).

## 6.5 Select Audit Trail Items (AU-5)

### Description

This menu will let you pick a specific audit trail entry to examine. An example of the menu is presented in Figure 6-6. For each item the following information will be listed: number of the user making the change, date of change, time of change, and title of change (A more detailed description of the item will be presented in Item Description (AU-6).

To select an item, move the cursor to the item and hit Return. If there are more items than can fit on the screen (indicated by the phrase more at the bottom of the menu) you can scroll up the menu to the view these items.

### Abort Options

Select Audit/Update Option

### Follow-On Frames

Item Description (AU-6).

SDT AUDIT/UPDATE MODE

Select Audit Trail Entry of Interest:

Users	Date	Time	Audit Entry Title
001	04/19/83	12.385	<u>Addition of Task Three</u>
001	04/20/83	12.385	Addition of Task Four

-ABORT-

Figure 6-6. Select Audit Trail Items (AU-5)

## 6.6 Item Description (AU-6)

### Description

During this frame, a more detailed description of the audit trail item will be listed in the screen. (see Figure 6-7).

When you have completed your examination of the item, you can either select another trail item for examination or exit the audit/update mode. To select one of these options, move the cursor to the desired option and hit Return.

### Abort Options

None

### Follow-On Frames

If you select the option for examining another audit trail item, you will go to Select Audit Trail Items (AU-5).

If you select the no more items option, you will return to SDT Mode Select (SDT-4).

Addition of Task Three

---

Task three was added to reflect the addition of a Heads-Up-Display to the system. Task three was added by Training Developments Directorate at Fort Rucker.

---

- Select Another Audit Trail Item
- Exit Audit/Update Mode

Figure 6-7. Item Description (AU-6)

## 6.7 Select Entity Type (AU-7)

### Description

This menu allows you to select which of the SDT entities and/or subentities you will limit your audit trail examination to (see Figure 6-8).

To select the entities and subentities move the cursor to the desired entity and hit Return. If desired, move the cursor to another item and hit Return. When you have selected all the items you want, select No More Entities.

### Abort Options

Select Audit/Update Option (AU-1).

### Follow-On Frames

Select Audit Trail Items (AU-5).

SDT AUDIT/UPDATE MODE

Select Entities of Interest in Screening Audit Trail Entries:

-ABORT-

-ALL ENTITIES-

FUNCTIONS

Perform. Goal

Envir. Impact

Threat Impact

Mission Impact

EQUIPMENT

Software Requirements

Comparable Equip.

Information Input

Information Output

TASK

Task Numbers

Freq/Duration Meas.

Training Assignment

Task Element

Task Condition

-more-

Figure 6-8. Select Entity Type (AU-7).

## 6.8 Enter Audit Trail Description (AU-8)

### Description

During this frame, you will be required to enter a description of the data base changes you are attempting to upload to the computer (see Figure 6-9). More specifically, in order for the SDT to execute the upload, you will be required to enter (1) a title for the changes, and (2) twelve lines of text providing a more detailed description of the item. The description should indicate, in general terms, the items that were changed, why they were changed, and if appropriate what they were changed to. To provide guidance on the type of information that is appropriate for an audit trail entry, and to provide a context for your description, descriptions of the last twenty audit trail entries will be displayed on the screen at the same time you are required to input the audit trail name.

To enter data, you must first type in the data for the title in the blank spaces on the screen. Then type in the more detailed description. Twelve lines of text must be entered for the latter.

### Abort Options

### Select Audit/Update Option (AU-1)

### Follow-On Frames

### Action Taken Message (AU-3).

LOG ON MODE

Below are recent audit trail titles: Enter audit trail title  
for this update:

- Addition of Task Four
- Addition of Task Three

-----  
-----  
-----  
-----

Figure 6-9. Enter Audit Trail Description (AU-8).

**THIS PAGE INTENTIONALLY LEFT BLANK**

## SECTION 7 - INPUT MODE

The input mode is used to enter data, to modify large amounts of data, and to create entities. The Input Mode may be distinguished from the Correct Mode which is used to modify small amounts of data (that is specific attributes of specific entities). The Correct Mode must be used to modify system attributes (system name, system description) to modify entity names, and output report names.

There are seven major menus or frames in the Input Mode:

- o I-1 Select Input Entity. This frame allows you to select which of the seven SDT entities (functions, missions, equipments, tasks, courses, duty positions, and media) on which you would like to enter data.
  
- o I-2 Select Input Mode. This menu allows you to select which of three input modes you would like to use to input data. The three input modes are (1) inputting data destroying what is already in the data base, (2) inputting data except when data is missing (this allows to quickly fill in holes in the data base), and (3) inputting data giving you the option of destroying the data in the data base.

- o I-3 Select Attributes. These menus allow you to select the attributes you want to modify and/or input.
  
- o I-4 Select Level. This menu is used with the two hierarchical entities (functions and equipments) to select which level of the hierarchies on which to input data.
  
- o I-5 Select Specific Entities. This menu is used with non-hierarchical entities to select the specific entities whose attributes will be input or modified.
  
- o I-6 Enter Attributes. These frames are used to enter data.
  
- o I-7 Select Format. This menu allows you to select an existing input/output format for inputting data. By selecting one of these formats, you do not have to select attributes (I-3).

An overview of the logic underlying the Input Mode menus/frames is provided in Figure 7-1. A more detailed description of the Input Mode menus/frames is provided in the sections which follow.



## 7.1 Select Input Entity (I-1)

### Description

This menu allows user to select one of the seven entities to input or modify data. The menu is displayed in Figure 7-2.

### Abort Options

Exit SDT - By selecting this option, you can terminate your current session on the SDT.

Exit Input Mode - If you select this option, you will return to the Mode Select Menu (SDT-4).

### Follow-On Frames

If there is data in the data base for the entities you selected, you will go to the Select Input Mode (I-2).

If there is no data on the entity selected and there are no Input/Output (I/O) formats for the entity you selected you will go to Select Attributes (I-3).

If there is no data on the entity selected and there are I/O formats for the entity you will go to Select Format (I-7).

SDT INPUT ENTITY MODE

SELECT ENTITY TO INPUT FROM LIST BELOW:

-EXIT SDT-  
-EXIT INPUT ENTITY MODE-  
FUNCTION  
EQUIPMENT  
TASK  
COURSE  
MISSION  
MEDIA  
DUTY POSITION .

Figure 7-2. Select Input Entity (I-1).

## 7.2 Select Input Mode (I-2)

### Description.

An example of this menu is displayed in Figure 7-3. The menu allows you to select from four different options for inputting or modifying data.

- o Destroying what is already present - this input mode should be used, when the most of the data for the entities being examined is no longer applicable.
- o Inputting except when present - this mode allows you to fill in holes in the data base. For example, if you wanted to input data in task frequencies for any tasks which do not yet have this information, you would select this mode.
- o Giving Option - By selecting this input mode, you will be given the option of destroying what is in the data base. The old value will appear on the screen. At the same time you can enter a new value.
- o Create New Entity - This input mode is very important since it allows you to create new entities. This is the only place in the SDT where you can do this. If you select this input mode you will still have the option of entering additional attributes along with the entity information.

SDT INPUT ENTITY MODE

Select Input Mode:

- ABORT-
- ADD ATTRIBUTES DESTROYING IF ALREADY PRESENT-
- ADD ATTRIBUTES EXCEPT WHEN ALREADY PRESENT-
- ADD ATTRIBUTES GIVING ME OPTION WHEN ALREADY PRESENT-
- CREATE NEW TASK-

Figure 7-3. Select Input Mode (I-2).

Abort Options

Abort - This will return you to Select Input Entity (I-1).

Follow-On Frames

If there are no I/O formats for the entity you have selected, you will go to Select Attributes (I-3).

If there are formats, you will go to Select Format (I-7).

**THIS PAGE INTENTIONALLY LEFT BLANK**

### 7.3 Select Attributes (I-3)

#### Description

An example of this menu is displayed in Figure 7-4. This menu allows you to select the attributes on which to input data. To select attributes, move the cursor up and down the screen and press Return when it is on the item you want to select. To select another attribute, move the cursor to the desired item and hit Return again. If all the attributes for an entity do not fit on the screen, (this is indicated by the phrase more on the bottom of the screen), you can view and select the remaining attributes by "scrolling" the screen up (see Section 3.2). When you have selected all of the attributes you desire, hit No More Attributes. You may select all attributes by moving the cursor to this option and hitting Return. The All Attributes option can be used to reverse the current status of the attributes selected; that is, it will "unselect" the selected items highlighted on the screen or select the items not currently highlighted. This option can be of great value when you want to select a large number of attributes. For example, if you wanted to select 27 of 30 available attributes, you would hit All Attributes and then move the cursor to the three undesired elements and unselect each of these three by hitting Return when the cursor is on each item.

If you have selected any subentities as some of the items on which you would like to input data, additional attribute selection menus for each of these subentities will follow the main attribute selection menu. These additional menus will ask you to select the subentity attributes.

SDT INPUT ENTITY MODE

Select FUNCTION Attributes to enter:

-ABORT-

-ALL ATTRIBUTES-

-NO MORE ATTRIBUTES-

COLLECTIVE TASK NAME

COLLECTIVE TASK NBR

ALTERN. COL. TASK NBR

PERFORMANCE GOAL

ENVIRONMENTAL IMPACT

THREAT IMPACT

MISSION IMPACT

PRECEEDING FUNCTION

CONCURRENT FUNCTION

SUCCEEDING FUNCTION

EQUIPMENT

Figure 7-4. Select Attributes (I-3).

### Abort Options

Abort - By selecting this option, you will return to Select Input Entity (I-1).

### Follow-On Frames

- o If you have selected subentities, the Select Attribute menus for these menus will appear on the screen one after another until subentity attribute selection is completed.
  
- o If you have selected a hierarchical entity (that is, functions or equipments) and you have not selected the create input mode you will go to Select Level (I-4).
  
- o If you have not selected a hierarchical entity and you have not selected the create input mode you will go to Select Entity I-5.
  
- o If you have selected a hierarchical entity (that is functions or equipments) and you have selected the create input mode you will go to Enter Attributes (I-6)
  
- o If you have not selected a hierarchical entity and you have selected the create input mode, you will go to Enter Attributes (I-6)

**THIS PAGE INTENTIONALLY LEFT BLANK**

## 7.4 Select Level (I-4)

### Descriptions

These menus allow you to select the level of a hierarchical entity (functions or equipments) on which to input data. There are two versions of this frame. The first version, displayed in Figure 6-5, is used to make selections at the highest level in the hierarchy. The second version, displayed in Figure 7-6, is used to make selections at lower levels in the hierarchy. If you select one of the lower levels listed in a menu (for example, if you were to choose function 1.1 in Figure 7-5), you will move to another menu asking you to make selections among the subelements at the next lowest level (for example, the subfunctions of Function 1.1). If there are no subelements at that lower level the program will assume that you want to input data at the lower level and you will automatically go to Enter Attributes. If you select Enter data at this level, the program will allow you to enter data for the lower level elements.

### Abort Options

Abort (at lower levels) - By selecting this option you will return to the highest level menu.

### Follow-On Frames

If you select a lower level element in the hierarchy, you will go to another Select Level frame.

Once you have selected the level at which you would like to input data, you will go to Enter Attribute (I-6).

LEVEL 1 FUNCTION SELECT

Select FUNCTION Level to Input to:

-ABORT-

-INPUT ATTRIBUTES HERE AT LEVEL 1-

1.0 OPERATE SINGARS

2.0 SUPPORT SINGARS

Figure 7-5. Select Level - Highest Level (I-4).

LEVEL 2 FUNCTION SELECT

FUNCTION

1.0 OPERATE SINCGARS

Select FUNCTION Level to Input to:

-ABORT-

-INPUT ATTRIBUTES HERE AT LEVEL 2-

-RETURN TO LEVEL 1-

1.1 COMMUNICATE

1.2 COMMAND AND CONTROL

1.3 MOVE

1.4 SURVIVE THREAT ENVIRONMENT

Figure 7-6. Select Level - Lowest Level (I-4).

**THIS PAGE INTENTIONALLY LEFT BLANK**

## 7.5 Select Specific Entities

### Description

This menu will allow you to select specific entities in the data base on which to input or modify data. An example of this menu is displayed in Figure 7-7.

To select entities, move the cursor up and down on the screen and press Return when it is on the item you want to select. To select another entity move the cursor to the desired item and hit Return again. If all of the entities do not fit on the screen (this is indicated by the phrase more on the bottom of the screen, you can view and select the remaining entities by "scrolling" the screen up (see Section 3.2). When you have selected all of the entities you desire, hit No More. You may select all entities by moving the cursor to this option and hitting Return. The All Entities option can be used to reverse the current status (highlighted) or nonhighlighted) of the entities selected. (Thus you can use this option to "unselect" the selected items which are highlighted on the screen or to select the items not currently highlighted).

### Abort Options

- o Select Input Entity (I-1)

### Follow-On Frames

- o Enter Attributes (I-6)

SDT INPUT ENTITY MODE

Select TASKS to go through:

-ABORT-

-ALL TASKs-

REMOVE AND REPLACE AN/TSQ-38  
INSTALL OPTIONAL EQUIPMENT  
PERFORM PREOP. CHECK  
PERFORM POST-OP CHECK  
REMOVE OPTIONAL EQUIPMENT  
INITIALIZE FREQUENCY HOPPING  
PERFORM PRE-OP CHECKS  
PERFORM POST-OP CHECKS  
CONTROL A RADIO NET WITH A CONTROL UNIT  
OPERATE A RADIO NET  
INITIALIZE COMSEC

Figure 7-7. Select Specific Entities (I-5).

## 7.6 Enter Attributes (I-6)

### Description

These frames are used to input or modify attributes. There are five versions of this frame. The first version, displayed in Figure 7-8, is used to input data for attributes which have a predefined set of response options. To use this frame, you simply move the cursor to the desired response and hit Return. The second version of this frame is used with attributes which do not have a predefined set of response options (see Figure 7-9). To enter the attribute, simply use the keyboard to type in the appropriate information and hit Return. If you make a mistake you can correct it as long as you have not hit Return, by hitting the left arrow key to move backwards and retyping the information. If you try to enter letters for a numeric attribute, you will get an error message and the program will not accept your data. The program will also automatically place decimal points in the correct location for numeric data. If you do enter any data the program will assume that you want to abort and three options will appear on the screen allowing you to (1) abort the inputting of the entity, (2) skip to the next entity or (3) skip to the next attribute.

If selected the input mode which gives you the option of destroying the data currently in the data base, the frames listed in Figures 7-8 and 7-9 will be replaced with the versions listed in Figures 7-10 (version 3) and 7-11 (version 4). The latter frames allow you to examine the current value for the attribute, and either modify the data or leave it unchanged. If you select the leave it option,

REMOVE AND REPLACE AN/TSQ-38

Select STATUS

DRAFT

NEW

EXISTING

Figure 7-8. Enter Attributes (I-6)

1.1 COMMUNICATE

Enter COLLECTIVE TASK NAME:

-----

-----

THEN PRESS RETURN

(MAKE NO ENTRY TO ABORT)

Figure 7-9. Enter Attributes (I-6).

COURSE: SINGARS OPERATOR COURSE

Current STATUS is:

MODIFIED

-LEAVE IT-  
CHANGE IT

Enter STATUS:

-ABORT-  
PROPOSED  
MODIFIED  
EXISTING

Figure 7-10. Enter Attributes (I-6).

COURSE: SINGARS OPERATOR COURSE

Current COURSE LENGTH is:

18

-LEAVE IT-

-CHANGE IT-

Enter Course Length:

-----

-----

THEN PRESS RETURN

(MAKE NO ENTRY TO ABORT)

Figure 7-11. Enter Attributes (I-6).

the program will give you the option of (1) returning to Select Entity Input (I-1), (2) skipping to the next entity, or (3) skipping to the next attributes (see Figure 7-11). If you choose (2) and there are no more entities, the program will return to Select Input Entity (I-1).

The fifth version of the frame displayed in Figure 7-12 is used to create hierarchical entities (functions or equipments). The program allows you to enter additional items at the level of the hierarchy you selected in Select Level (I-4), and enter the name and the title of the hierarchical entity. An identical version of the frame will then appear on the screen, allowing you to continue to input entities at that level. If you do not have any additional entities to enter, make no entries. The program will then take you back to the Select Level (I-4) frame.

Unless you select one of the abort options, frames for entering data on the attributes you selected will appear on the screen one after another. The order in which the attributes will appear is identical to the order in which they are stored in the data base. More specifically,

- o entities are stored in the order in which they are entered, and
- o subentities and attributes are stored in the order listed in Table 13-1.

Current System Name: SDT EXAMPLE

-CHANGE IT-  
-LEAVE IT

-----  
-----

THEN PRESS RETURN

(MAKE NO ENTRY TO ABORT)

Figure 7-12. Enter Attributes (I-6).

### Abort

- o By hitting abort or making no entry during version 1, 2, 3, and 4 of this frame, you will be given the option of (1) aborting to Select Input Entity (I-1), (2) skipping to next entity, or (3) skipping to the next entity attribute.
  
- o If you select Abort during version 5 of this frame you will return to the Select Level (I-4).

### Follow-On Frames

- o If there is additional data to enter, additional Enter Attribute frames will follow.
  
- o Once all the data has been entered you will be returned to Select Input Entity (I-1).

## 7.7 Select Format (I-7)

### Description

This menu allows you to select one of the input/output (I/O) formats already stored in the data base to guide your input (see Figure 7-13). By selecting an existing I/O format you can avoid the somewhat tedious process of specifying the attributes for which you would like to input data. The program will assume that you want to enter the attributes contained in the I/O format. There is a standard set of I/O formats for each entity which are built into the SDT. These standard formats are described in Appendix B. In addition, you can create your own formats in the output mode. Procedures for creating your own formats are described under the Output Mode (see Section 9).

### Abort Options

- o Select Input Entity (I-1)

### Follow-On Frames

- o If you select an existing I/O format and you are dealing with a hierarchical entity, you will return to Select Level (I-4).
- o If you select an existing I/O format and you are not dealing with a hierarchical entity, you will return to Select Entity (I-6).
- o If you decide not to use an existing I/O format and decide to select your own attributes, you will go to Select Attributes, (I-3).

SDT INPUT ENTITY MODE

SELECT OUTPUT FORMAT TO DETERMINE INPUT ATTRIBUTES:

-ABORT-

-SELECT MY OWN ATTRIBUTES-

SIMPLE FUNCTION LISTING

COLLECTIVE TASKS BY FUNCTION

FUNCTIONS BY EQUIPMENT

FUNCTION SEQUENCE

TASKS BY FUNCTION

EQUIPMENTS BY FUNCTION

HORIZONTAL TEST

FUNCTION PERFORMANCE GOALS

ENVIRONMENTAL IMPACTS

THREAT IMPACTS

MISSION IMPACTS ON FUNCTIONS

Figure 7-13. Select Format (I-7).

**THIS PAGE INTENTIONALLY LEFT BLANK**

## SECTION 8 - CORRECT MODE

The Correct Mode is used (1) to modify a small amount of data (for example, a specific attribute of a specific entity such as the task frequency of the task Remove and Replace Engine) (2) to change the general system attributes (system name, system description, output report names) which were initially created to describe the system, (3) to modify the entity names and numbers (if a hierarchical entity), and (4) to modify the titles of output formats. The Correct Mode is the only mode which can be used to perform the last three types of modifications. There are five major menus or frames in the Correct Mode.

C-1 Select Correct Entity. This frame allows you to select which of the seven SDT entities (functions, missions, equipments, tasks, courses, duty positions, media) or system description attributes (system name, system description, output report names) you would like to correct.

C-2 Select Specific Entity. This menu allows you to select the specific task (e.g., Remove and Replace Engine) whose attributes you would like to correct or modify.

C-3 Select Attribute. This menu allows you to select the attributes to be corrected.

C-4 Modify Attribute. These frames are used to correct the attribute data.

C-5 Correct System Attribute or Output Report Name. This frame is used to correct system attributes or output report names. An overview of the logic underlying the Correct Mode menus/frames is provided in Figure 8-1. A more detailed description of the Correct Mode menus and frames is provided in the sections which follow.

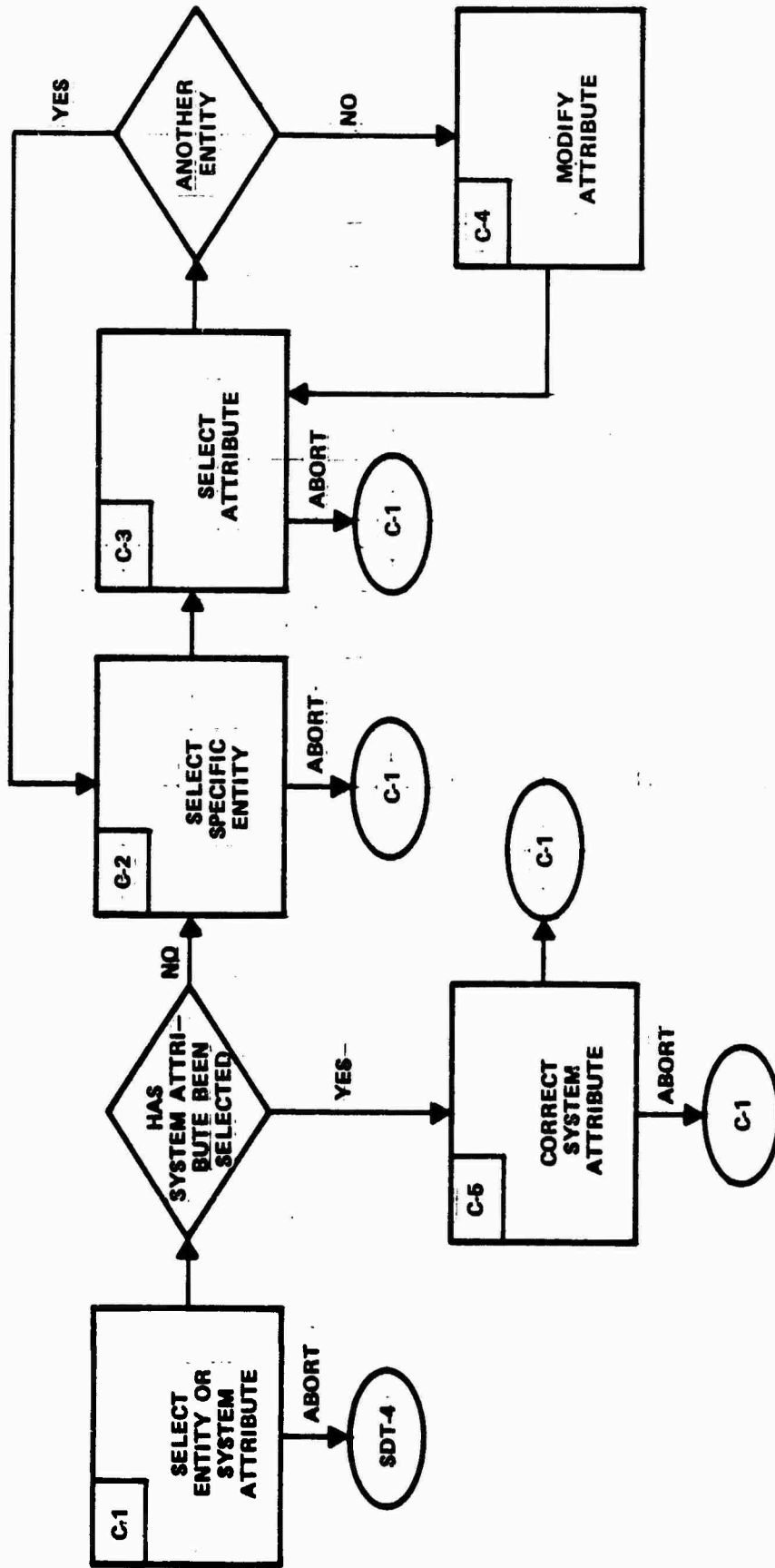

Figure 8-1 Overview of Correct Mode Logic

## 8.1 Select Correct Entity (C-1)

### Description

This menu allows users to select which of the seven types of SDT entities or system attributes (system name, system description, output report names) will be corrected. This frame is displayed in Figure 8-2.

### Abort Options

- o Exit SDT - Selecting this option, you will terminate your current session on the SDT.
- o Exit Correct Mode - This will return you to the Mode Select Menu (SDT-4)

### Follow-On Frames

- o If you have selected a system attribute to correct you will go to Correct System Attribute (C-1).
- o If you have selected one of the seven SDT entities, you will go to Select Specific Entity (C-2).

SDT CORRECT ENTITY MODE

SELECT ENTITY TO CORRECT FROM LIST BELOW:

-EXIT SDT-  
-EXIT CORRECT ENTITY MODE-  
SYSTEM NAME  
SYSTEM DESCRIPTION  
OUTPUT FORMAT NAMES  
FUNCTION  
EQUIPMENT  
TASKS  
COURSE  
MISSION  
MEDIA  
DUTY POSITION

Figure 8-2. Select Correct Entity (C-1).

## 8.2 Select Specific Entity (C-2)

### Description

This menu will allow you to select which specific entity or entities in the data base on which you would like to correct data. An example of this menu is displayed in Figure 8-3.

To select an entity to be corrected, move the cursor up and down on the screen and press Return when it is on the item you want to select. To select another entity, move the cursor to the desired item and hit Return again. If all of the entities do not fit on the screen (this is indicated by the phrase More on the bottom of the screen, you can view and select the remaining entities by "scrolling" the screen up (see Section 3.2). When you have selected all of the attributes you desire, hit No More. You may select all entities by moving the cursor to this option and hitting Return. The All Entities option can be used to reverse the current status of the entities selected. (Thus, you can use this option to "unselect" the selected items which are highlighted on the screen or to select the items not currently highlighted.)

### Abort Options

- o Select Correct Entity (C-1)

### Follow-On Frames

- o Select Attributes (C-3)

Select COURSE(s):

-ABORT-  
-SELECT ALL COURSES-  
SINGARS OPERATOR  
SINGARS MAINTENANCE  
M-1 OPERATOR'S COURSE

Figure 8-3. Select Specific Entity (C-2)

### 8.3 Select Attribute (C-3)

#### Description

An example of this menu is displayed in Figure 8-4. This menu allows you to select the attribute to be corrected. To select an attribute, move the cursor up and down the screen and press Return when it is on the item you want to select.

If you have selected a subentity as the item on which you would like to correct data, the attribute selection menu for this subentity will follow the main attribute selection menu.

#### Abort Options

- o Select Correct Entity (C-1)

#### Follow-on Frames

- o If you select Another Entity, you will go to Select Specific Entity (C-2). Otherwise, you will go to Modify Attribute. (C-4)

COURSE: SINGARS OPERATOR COURSE

Select Attribute to Correct for COURSE:  
SINGARS OPERATOR COURSE

-ABORT-  
-ANOTHER COURSE-  
TITLE  
COURSE NUMBER  
COURSE LENGTH  
TYPE  
ALTERNATIVE  
STATUS  
COMPARABLE COURSE  
COMPARABLE NUMBER  
PREREQUISITE COURSES  
FOLLOW-ON COURSES  
ATTRITION RATE  
MAXIMUM CLASS SIZE  
CLASS FREQUENCY  
RESOURCE REQUIREMENTS  
COURSE COSTS  
STUDENT INPUT REQTS.  
(more)

Figure 8-4. Select Attribute (C-3).

## 8.4 Modify Attributes (C-4)

### Description

This frame is used to modify attributes. There are two versions of this frame (see Figures 8-5 and 8-6). The first version, displayed in Figure 8-5, is used to modify attributes which have a predefined set of response options. When this frame first appears on the screen, the old value of the attribute will be listed on the screen. You will have the option of either changing the value or leaving it. If you decide to change it (indicated by hitting Change It), the predefined options for this attribute will appear on the screen. To select an option, move the cursor to the appropriate option and hit Return.

The second version, displayed in Figure 8-6, is used to modify attributes which do not have a predefined set of response options. When this frame first appears on the screen, the old value of the attribute will be listed on the screen. You will have the option of either changing the value or leaving it. If you decide to change it (indicated by hitting Change It), dashed lines will appear on the screen indicating where you can type in the new value for the attribute. Type in the appropriate information and hit Return. You can correct mistakes before hitting Return by moving the cursor to the left with the left arrow key and retyping the information.

### Abort Options

- o If you make no entry, or select abort, you will return to Select Attribute (C-3).

SINGARS OPERATOR COURSE

Enter COURSE LENGTH:

Old entry is:

66

LEAVE IT

CHANGE IT

-----

-----

THEN PRESS RETURN

(MAKE NO ENTRY TO ABORT)

Figure 8-5. Modify Attributes (C-4).

REMOVE AND REPLACE AN/TS Q 38

Select STATUS:

Old entry is:

DRAFT

LEAVE IT

-CHARGE IT-

Select STATUS:

-ABORT-

DRAFT

NEW

EXISTING

Figure 8-6. Modify Attribute (C-4).

Follow-On Frames

- o Select Attribute (C-3)

## 8.5 Correct System Attribute (C-5)

### Description

This frame is used to correct system attributes. (that is, system name, system description and output report names). An example of this frame is displayed in Figure 8-7. The current version of the system attribute will appear at the top of the screen. Below it will be a menu giving you the option of changing the attribute or leaving it as it is. If you decide to leave it, you will be returned to the Select Correct Entity (C-1) frame. If you decide to change it, space will be provided for you to type in the corrected information. After you have typed in the corrected information and you are sure it is correct, hit Return. You can correct mistakes before hitting Return by moving the cursor to the left with the left arrow key and retyping the information. If you make no entry and hit Return you will go back to Select Correct Entity (C-1) and no corrections will be made in the data.

### Abort Options

- o By making no entry, you can return to Select Correct Entity (C-1)

### Follow-on Frames

- o Select Correct Entity (C-1)

Current System Name: SDT NEW TEST

CHANGE IT  
-LEAVE IT-

-----

-----

THEN PRESS RETURN

(MAKE NO ENTRY TO ABORT)

Figure 8-7. Correct System Attribute (C-5).

**THIS PAGE INTENTIONALLY LEFT BLANK**

## SECTION 9 - OUTPUT MODE

The Output Mode is used to obtain output and to create input/output formats.

There are eleven major menus or frames in the Output Mode.

- o 0-1 Select Output Entity. This frame allows you to select which of the seven SDT entities (functions, missions, equipments, tasks, courses, duty positions, and media) on which you will obtain output.
- o 0-2 Select Output Device. This menu allows you to select the device or location (for example, screen printer) where data will be printed/displayed.
- o 0-3 Select Output Format. This allows you to select an existing input/output format for data. If you select one of these formats, you will not have to select attributes (0-4).
- o 0-4 Select Attributes. This menu allows you to select the attributes to be printed/displayed.
- o 0-5 Design Format. These frames allow you to construct an output format.

- o 0-6 Enter Column Heading. This format allows you to enter a heading for any columns you create in your output format.
- o 0-7 Enter Output Heading. This format allows you to enter a heading for the output report you have created. This heading will be printed at the top of each page of the report.
- o 0-8 Enter Report Name. This format allows you to enter a permanent name for the input/output report you have located. This heading will appear on all future Select Output Format (0-3) menus.
- o 0-9 Select Specific Entities. This menu is used with non-hierarchical entities to select which specific entities on which you would like to output data.
- o 0-10 Select Level. This menu is used with the two hierarchical entities (functions and equipments) to select the level(s) of these entities for which output will be obtained.
- o 0-11 Output. During these frames the data is output on the devices selected in 0-2.

An overview of the logic underlying the Output Mode menus and frames is provided in Figure 9-1. A more detailed description of the Output Mode menus/frames is provided in the sections which follow.

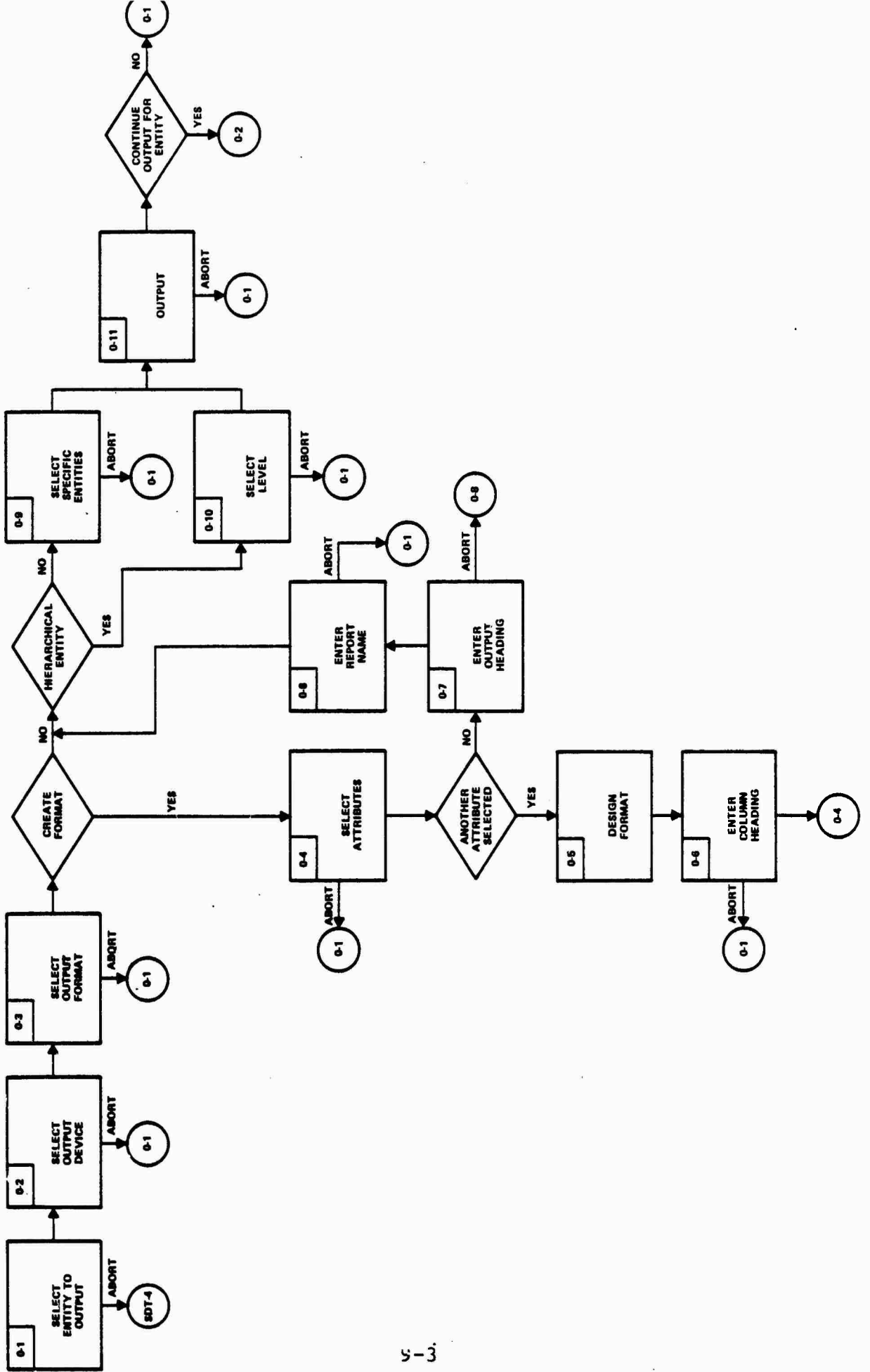

Figure 9-1 Overview of Output Mode Logic

## 9.1 Select Output Entity (0-1)

### Description

This menu allows you to select which of the seven entities on which data will be obtained. The menu is displayed in Figure 9-2. To select an entity, move the cursor to the desired option and hit Return.

### Abort Options

- o Exit SDT. Selecting this option will terminate your session on the SDT.
- o Exit Output Mode - Selecting this option will take you back to the Mode Select Menu (SDT-4)

### Follow-On Frames

- o Select Output Device (0-2)

SDT OUTPUT ENTITY MODE

SELECT ENTITY TO OUTPUT FROM LIST BELOW:

-EXIT SDT-  
-EXIT OUTPUT ENTITY MODE-  
FUNCTION  
EQUIPMENT  
TASK  
COURSE  
MISSION  
MEDIA  
DUTY POSITION

Figure 9-2. Select Output Entity (0-1).

## 9.2 Select Output Device (0-2)

### Description

This menu allows you to select the output device (for example CRT screen, printer) on which you would like to display or print your data. An example of this menu is presented in Figure 9-3. Potential output devices must be identified during the Data Base Set-Up Process (see Section 4). The SDT Base Director will modify the software to insure that software interfaces with the selected output devices are properly constructed. To select a device move the cursor to the desired option and hit Return.

### Abort Options

- o Select Output Entity (0-1)

### Follow-on Frames

- o Select Output Format (0-3)

Select Output Device:

-ABORT-

CRT SCREEN  
PRINTER

Figure 9-3. Select Output Device (0-2).

### 9.3 Select Output Format (0-3)

#### Description

This menu allows you to select input/output (I/O) formats already stored in the data base (see Figure 9-4). You also have the option of creating your own format. By selecting an existing I/O format you can avoid the somewhat tedious process of specifying the attributes for which you would like to output data. The program will assume that you want to output on the attributes contained in the I/O format. There is a standard set of I/O formats for each entity which are built into the SDT. These standard formats are described in Appendix B. In addition, you can create your own formats. Procedures for creating your own formats are described under the Design Format (0-5). To select a format, move the cursor to the desired option and hit Return.

#### Abort Options

#### Select Output Entity (0-1)

#### Follow-on Frames

- o If you select an existing format, and the entity you have selected is hierarchical, you will go to Select Level (0-10)
- o If you select an existing format, and the entity you have selected is not hierarchical, you will go to Select Entity (0-9)
- o If you do not select an existing format, you will go to Select Attribute (0-4)

Select Output Device:

-ABORT-  
CRT SCREEN  
PRINTER

Select Output Format:

-ABORT-  
-CREATE YOUR OWN FORMAT  
COURSE LISTING  
COURSE DESCRIPTION  
COURSE SCENARIO AND RESOURCE INFORMATION  
YEARLY STUDENT INPUTS - LOCATION ONE  
COURSE COSTS - PART 1  
COURSE COSTS - PART 2  
COURSE OUTLINE  
TASKS BY COURSE  
MEDIA BY COURSE MODULE

Figure 9-4. Select Output Format (0-3).

## 9.4 Select Attribute (0-4)

### Description

This menu allows you to select an attribute to include in your output report. After selecting an attribute you will move to Design Format (0-5) where you will be required to describe how the attribute will be displayed on your output report. You will then come back to this menu, Select Attributes, to select another attribute. When you have selected all the attributes you want to include in your output report, hit No More Attributes.

An example of the menu is presented in Figure 9-5. To select an attribute, move the cursor up and down on the screen and press Return when the cursor identifies the item you want to select. If all of the attributes for an entity do not fit on the screen (this is indicated by the phrases more on the bottom of the list), you can view and select the remaining attributes by "scrolling" the screen up (see Section 3.2).

### Abort Options

- o Select Output Entity (0-4)

### Follow-on Frames

- o If you have selected an attribute, you will go to Design Format (0-5).
- o If you have selected No More Attributes you will go to the Enter Output Heading (0-8).

Select First COURSE Attribute:

-ABORT-

TITLE

COURSE NUMBER

COURSE LENGTH

TYPE

ALTERNATIVE

STATUS

COMPARABLE COURSE

COMPARABLE NUMBER

PREREQUISITE COURSES

FOLLOW-ON COURSES

ATTRITION RATE

MAXIMUM CLASS SIZE

CLASS FREQUENCY

RESOURCE REQUIREMENTS

COURSE COSTS

(more)

Figure 9-5. Select Attribute (0-4).

## 9.5 Design Format (0-5)

### Description

These frames allow you to design your own output format. The design format frame is listed in Figure 9-6. You can create two types of output fields, horizontal and vertical.

In the horizontal field, the data element will be listed in a row on the same line as its heading. In a vertical field, the data elements will be listed in a column under their heading (see Appendix B for example of Output Reports).

To create a horizontal field for the attribute you have selected, you must move the cursor all the way to the left (beyond the margin) until the message HORIZONTAL DISPLAY appears and then hit Return. You can cancel the HORIZONTAL DISPLAY by moving the cursor to the right before hitting RETURN.

To create a vertical display, move the cursor to the desired location for your left margin, and hit RETURN. Then move the cursor to the desired location for your right margin and hit RETURN. (The program will display the number of the column where your cursor is currently located). If you attempt to create a report that exceeds the available width of the device you have selected, the program will provide you with a message indicating that your report will be truncated.

You must create all your horizontal fields before you create your vertical fields. Thus, you cannot create vertical fields, then add a horizontal field to your report. Table 9-1 demonstrates which types of formats are acceptable and

Select First COURSE Attribute:

-ABORT-

TITLE

COURSE NUMBER

COURSE LENGTH

TYPE

ALTERNATIVE

STATUS

COMPARABLE COURSE

COMPARABLE NUMBER

PREREQUISITE COURSES

FOLLOW-ON COURSES

ATTRITION RATE

MAXIMUM CLASS SIZE

CLASS FREQUENCY

RESOURCE REQUIREMENTS

COURSE COSTS

(more)

Attr. Nbr.

Cur Width

Max. Width

Curren

1

0

80

Cursor

Use arrows to move cursor to desired starting column.

Then press RETURN. Cursor starts as far left as

possible.

Column

1

Figure 9-6. Design Format (0-5).

Table 9-1. Acceptable Output Report Formats.

ACCEPTABLE

Horizontal Display

Horizontal Display

Horizontal Display

Column



Column



Column



Column



---

UNACCEPTABLE

Horizontal

Horizontal

Column

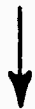

Column



Column



Column



Horizontal

Horizontal

which formats are not. The maximum number of fields you may create for any one report is 28. This includes both horizontal and vertical fields. To obtain a better idea of the types of output reports that can be created with the SDT, examine the standard output reports listed in Appendix B which are summarized in Table 9-2.

Not all of the SDT data elements may be used in a HORIZONTAL DISPLAY. HORIZONTAL DISPLAY may only be created for (1) entity names and attributes and (2) "solitary subentities", that is subentities which have a limit of one per entity (for example, only one of the subentity task number may be associated with a Task). Subentities which may have multiple entities per entity (for example the subentity Course Modules for the entity course) may not appear in a HORIZONTAL DISPLAY.

Additional guidance for creating output reports is provided in Section 13.

Remember that you can save the output reports you create and use them for future output. You can also use the reports to assist you in the input mode. By selecting an existing format while in the Input Mode you can skip the somewhat tedious process of selecting the attributes you want to enter.

#### Abort Options

- o There are no abort options for this frame. If you make a mistake and want to destroy the output report you're working on, enter nothing in the Enter Column Heading frame (0-6). This will return

you to the Select Attributes (0-4), where you can abort to Select Output Entity (0-1). If you follow these actions, your entire output report will be destroyed.

Follow-on Frames

- o Enter Column Heading (0-4)

TOTAL COLUMN WIDTH	DATA ELEMENTS	REPORT
		<u>FUNCTIONS</u>
80	FUNCTION NUMBER, FUNCTION NAME	• SIMPLE FUNCTION LISTING
80	FUNCTION NUMBER, FUNCTION NAME, COLLECTIVE TASK NAME	• COLLECTIVE TASKS BY FUNCTION
80	FUNCTION NUMBER, FUNCTION NAME, PRECEDING FUNCTION, SUCCEEDING FUNCTION	• FUNCTION SEQUENCE
80	FUNCTION NUMBER, FUNCTION NAME, TASK NUMBER	• TASKS BY FUNCTION
80	FUNCTION NUMBER, FUNCTION NAME, EQUIPMENT #, EQUIPMENT NAME	• EQUIPMENTS BY FUNCTION
80	FUNCTION NUMBER, FUNCTION NAME, PERFORMING MEASURE, GOAL/STANDARD	• FUNCTION PERFORMANCE GOALS
80	FUNCTION NUMBER, FUNCTION NAME, ENVIRONMENTAL VARIABLE, VARIABLE IMPACTED, REFERENCE	• ENVIRONMENTAL IMPACTS
80	FUNCTION NUMBER, FUNCTION NAME, THREAT VARIABLE, VARIABLE IMPACTED, REFERENCE	• THREAT IMPACT
80	FUNCTION NUMBER, FUNCTION NAME, MISSION IMPACT VARIABLE, VARIABLE IMPACTED, REFERENCE	• MISSION IMPACTS ON FUNCTIONS
		<u>EQUIPMENTS</u>
80	EQUIPMENT NUMBER, EQUIPMENT NAME	• SIMPLE EQUIPMENT LISTING
80	EQUIPMENT NUMBER, EQUIPMENT NAME, TASK NUMBER, TASK NAME	• TASKS BY EQUIPMENT
80	EQUIPMENT NUMBER, EQUIPMENT NAME, MTBF, MTRR, MTBMA	• EQUIPMENT RELIABILITY DATA
80	EQUIPMENT NUMBER, EQUIPMENT NAME, # CREW, # ORGANIZATIONAL, # DS, # DEPOT	• NUMBER OF ITEMS SUPPORTED
80	EQUIPMENT NUMBER, EQUIPMENT NAME, COMPARABLE EQUIPMENT, AMOUNT OF DIFFERENCE	• COMPARABLE EQUIPMENT BY EQUIPMENT
80	EQUIPMENT NUMBER, GENERIC EQUIPMENT, EXISTING EQUIPMENT	• GENERIC EQUIPMENT LISTING
80	EQUIPMENT NUMBER, EQUIPMENT NAME, INFORMATION INPUT, INPUT SOURCE, INFORMATION OUTPUT, OUTPUT SOURCE	• INFORMATION INPUTS AND OUTPUTS
80	EQUIPMENT NUMBER, EQUIPMENT NAME, R&D COST, INVEST. COST, O&S COST, UNIT PRICE, CAT 5 COST, CAT 6 COST, CAT 7 COST, CAT 8 COST, CAT 9 COST	• EQUIPMENT COSTS
80	TASK NUMBER, TASK NAME	• SIMPLE TASK LISTING
80	TASK NUMBER, TASK NAME, TASK ELEMENT NAME	• TASK ELEMENTS
80	TASK NUMBER, TASK NAME, TASK CONDITIONS, TASK STANDARDS, AMOUNT VALUE	• TASK CONDITIONS AND STANDARDS
80	TASK NAME, TASK TYPE, TASK STATUS, WORK AREA, TASK AREA, AMOUNT OF SUPERVISION, NUMBER OF PERFORMING	• EXTENDED TASK DESCRIPTION

Table 9-2. Standard SDT Output Formats. (continued)

REPORT	DATA ELEMENTS	TOTAL COLUMN WIDTH
<u>EQUIPMENTS</u> (continued)		80
• TASK SEQUENCE INFORMATION	TASK NUMBER, TASK NAME, PRECEDING TASK, SUCCEEDING TASK	80
• INITIATING AND TERMINATING CUES	TASK NUMBER, TASK NAME, INITIATING CUE, AND ASSOCIATED EQUIPMENT, TERMINATING CUE AND ASSOCIATED EQUIPMENT	80
• FAILURE MODES	TASK NUMBER, TASK NAME, FAILURE, % OF FAILURES	80
• TOOLS AND TEST EQUIPMENT	TASK NUMBER, TASK NAME, TOOLS/TEST EQUIPMENT, NUMBER, TYPE	80
• SKILLS AND KNOWLEDGES	TASK NUMBER, TASK NAME, SKILL/KNOWLEDGE, TYPE, CATEGORY, SKILL AND KNOWLEDGE CHARACTERISTIC ONE, SKILL AND KNOWLEDGE CHARACTERISTIC TWO	80
• LEARNING OBJECTIVES	TASK NUMBER, TASK NAME, LEARNING OBJECTIVE CHARACTERISTICS ONE AND TWO	80
• PERFORMANCE MEASURES	TASK NUMBER, TASK NAME, PERFORMANCE MEASURE, AMOUNT/VALUE	80
• TRAINING EMPHASIS RATINGS	TASK NUMBER, TASK NAME, % PERFORMING, % TIME, CONSEQUENCES OF INADEQUATE, TASK DELAY TOLERANCE, LEARNING DIFFICULTY, FREQUENCY OF PERFORMANCE, TIME BETWEEN ENTRY AND PERFORMANCE	80
• STIMULI - (PARTS 1 AND 2)	TASK NUMBER, TASK NAME, STIMULUS VARIABLES FROM ETES MEDIA SELECTION PROGRAM	80
• RESPONSES	TASK NUMBER, TASK NAME, RESPONSE VARIABLES, ETES MEDIA SELECTION PROGRAM	80
• FEEDBACK	TASK NUMBER, TASK NAME, FEEDBACK VARIABLES FROM ETES MEDIA SELECTION PROGRAM	80
<u>COURSES</u>		80
• COURSE LISTING	COURSE NUMBER, COURSE TITLE	80
• COURSE DESCRIPTION	COURSE NUMBER, COURSE TITLE, COURSE LENGTH, COURSE TYPE, ALTERNATIVE, STATUS, COMPARABLE COURSE, COMPARABLE COURSE NUMBER	80
• COURSE SCENARIO AND RESOURCE INFORMATION	COURSE NUMBER, COURSE TITLE, COURSE LENGTH, ATTRITION RATE, CLASS SIZE, FREQUENCY, NUMBER OF NORM GRADS, QUARTERS/MESS AVAILABLE, PER CENT OFFICERS, PER CENT TDY, INSTRUCTOR CONTACT HOURS PER CLASS, NUMBER OF INSTRUCTIONS, P8 REQUIREMENTS	80
• YEARLY STUDENT INPUTS (YSI)	COURSE NUMBER, COURSE TITLE, COURSE LENGTH, LOCATION, YSI-YEAR 1, YSI-YEAR 2, YSI-YEAR 3, YSI-YEAR-4, YSI-YEAR 5, YSI-STEADY STATE	80
• COURSE COSTS	COURSE NUMBER, COURSE TITLE, 23 COST VARIABLES	80
• QUASI-POI: PART 1	COURSE NUMBER, COURSE TITLE, MODULE TITLE, METHODS WITHIN MODULES, CONTACTS HOURS PER METHOD, STUDENT/INSTRUCTOR RATIO PER METHOD	80
• QUASI-POI: PART 2	COURSE NUMBER, COURSE TITLE, MODULE TITLE, TASKS	80

Table 9-2. Standard SDT Output Formats. (continued)

REPORT	DATA ELEMENTS	TOTAL COLUMN WIDTH
<p><u>COURSES (continued)</u></p>		
<ul style="list-style-type: none"> <li>• MEDIA BY COURSE</li> </ul>	<p>COURSE NUMBER, COURSE TITLE, MODULE TITLE, MEDIA</p>	80
<p><u>MISSIONS</u></p>		
<ul style="list-style-type: none"> <li>• MISSION PROFILE</li> </ul>	<p>MISSION NAME, ANNUAL NUMBER OF MISSIONS, ANNUAL OPERATING DAYS, MEAN DURATION, ANNUAL OPERATING DAY REQUIREMENTS</p>	80
<p><u>MEDIA</u></p>		
<ul style="list-style-type: none"> <li>• MEDIA DESCRIPTION</li> </ul>	<p>MEDIA TITLE, ALTERNATIVE, MEDIA NUMBER, ISSUE RATE PER STUDENT, PUBLICATION DATE, REVISION DATE, MEDIA TYPE-GENERAL, MEDIA TYPE-SPECIFIC, MAXIMUM DAILY OPERATING TIME, STUDENT INSTRUCTOR RATIO, INDEX OF EFFECTIVENESS, OVERALL INDEX OF EFFECTIVENESS, INDEX OF PERSONNEL REQUIREMENTS</p>	80
<ul style="list-style-type: none"> <li>• MEDIA COSTS</li> </ul>	<p>MEDIA NAME, 12 COST VARIABLES</p>	80
<ul style="list-style-type: none"> <li>• NUMBER OF MEDIA</li> </ul>	<p>MEDIA NAME, NUMBER IN YEARS ONE THROUGH SEVEN AND STEADY STATE</p>	80
<ul style="list-style-type: none"> <li>• DUTY POSITION DESCRIPTIONS</li> </ul>	<p>DUTY POSITION TITLE, DUTY POSITION NUMBER, MOS TITLE, MOS NUMBER, ASI TITLE, ASI NUMBER, SKILL LEVEL</p>	80
<ul style="list-style-type: none"> <li>• MANPOWER REQUIREMENTS</li> </ul>	<p>DUTY POSITION TITLE, MOS NUMBER, ASI NUMBER, START DATE, MANPOWER REQUIREMENTS IN YEARS ONE THROUGH SEVEN</p>	80
<ul style="list-style-type: none"> <li>• TASKS BY DUTY POSITION</li> </ul>	<p>DUTY POSITION TITLE, MOS NUMBER, ASI NUMBER, TASK NUMBER, TASK TITLE</p>	80
<ul style="list-style-type: none"> <li>• ORGANIZATIONAL REQUIREMENTS</li> </ul>	<p>DUTY POSITION TITLE, MOS NUMBER, ASI NUMBER, NUMBERS AND TITLES FOUR LEVELS OF ORGANIZATION</p>	80

## 9.6 Enter Column Heading (0-6)

### Description

This frame is used to enter column headings for each vertical field you created in Design Format (0-5). There is no need to assign names to an attribute assigned to a HORIZONTAL DISPLAY since these attributes are assigned the generic headings contained in the SDT data dictionary (see Appendix A).

An example of this frame is presented in Figure 9-7. To enter a heading, simply type the characters in the spaces provided on the screen and hit RETURN when you are done. If you make a mistake, you can correct it before hitting RETURN by backspacing the cursor over the erroneous information and retyping. Column headings may not exceed the length of the column width you have identified. The appearance of a report can be improved by centering the column heading in the middle of your margin.

### Abort Options

- o If you make no entry in the space left for the column heading, you will return to Select Output Entity (0-1) and this will destroy all previous work completed on that output report.

### Follow-on Frames

- o Enter Output Heading (0-7)

Enter Header for COURSE TITLE:

-----

-----

THEN PRESS RETURN

(MAKE NO ENTRY TO ABORT)

Figure 9-7. Enter Column Heading (0-6).

## 9.7 Enter Output Heading (0-7)

### Description

This frame will allow you to create a page heading for your output report. This heading will be repeated at the top of each page of the printed output report.

An example of this frame is presented in Figure 9-8. To enter a heading, simply type the characters in the spaces provided on the screen and hit Return when you are done. If you make a mistake, you can correct it by backspacing the cursor over the erroneous information and retyping. However, this must be done before you hit Return. The appearance of a heading can be improved by centering the heading in the middle of the page.

If you have made a mistake in a format and wish to replace it you can do so by creating the new format and entering an output heading that is identical to the heading for the old format. If you do this the program will then ask you if you want to save your old format and ignore the new one or if you want to delete the old format and replace it with the new one.

### Abort Options

- o If you do not want a heading at the top of your report, make no entry and hit RETURN. (This will take you to Enter Report Name (0-8))

### Follow-on Frame

Enter Report Name (0-8)

Enter a title to be displayed on first page of output:

-----  
-----

THEN PRESS RETURN

(MAKE NO ENTRY TO ABORT)

COURSE

Figure 9-8. Enter Output Heading (0-7).

## 9.8 Enter Report Name (0-8)

### Description

This frame allows you to create a permanent name for the output report you have created. This name will be used in all subsequent references to this report in the SDT program. Note that this name will not necessarily be identical to the headings which will be printed on your output reports (These headings were created in Enter Output Heading.) To make these two headings identical, you must enter the same information in this frame and in Enter Output Heading.

An example of this frame is presented in Figure 9-9. To enter a name, simply type the characters in the spaces provided on the screen and hit Return when you are done. If you make a mistake, you can correct it by backspacing the cursor over the erroneous information and retyping. However, this must be done before you hit Return.

### Abort Options

- o If you make no entry you will return to Select Output Entity and the output report you have created will be destroyed.

### Follow-on Frames

- o If you have selected a hierarchical entity (functions, equipments), you will go to Select Level (0-10).
- o If you have not selected a hierarchical entity, you will go to select Specific Entities (0-9)

Enter permanent name for this new format so that you can  
use it later without having to enter all the fields again:

-----  
-----

THEN PRESS RETURN

(MAKE NO ENTRY TO ABORT)

Figure 9-9. Enter Report Name (0-8).

## 9.9 Select Specific Entities (0-9)

### Description

This menu will allow you to select the specific entity or entities to be output. An example of this menu is displayed in Figure 9-10.

To select entities, move the cursor up and down on the screen and press Return when it is on the item you want to select. To select another entity, move the cursor to the desired item and hit Return again. If all of the entities do not fit on the screen (this is indicated by the phrase more on the bottom of the screen, you can view and select the remaining entities by "scrolling" the screen up (see Section 3.2). When you have selected all of the entities you desire, hit No More Entities. You may select all entities by moving the cursor to this option and hitting Return. The All Entities option can be used to reverse the current status of the attributes selected (Thus, you can use this option to "unselect" the selected items which are highlighted on the screen or to select the items not currently highlighted).

### Abort Options

- o Select Output Entity (0-1)

### Follow-on Frames

- o Output (0-11)

Select COURSE(s):

-ABORT-

ALL COURSES

SINGARS OPERATOR

SINGARS MAINTENANCE

Figure 9-10. Select Specific Entities (0-9).

## 9.10 Select Level (0-10)

### Descriptions

These menus allow you to select the level of a hierarchical entity (functions or equipments) on which to output data. There are two versions of this frame. This first version displayed in Figure 9-11 is used to make selections at the highest level in the hierarchy. The second version, displayed in Figure 9-12, is used to make selections at lower levels in the hierarchy.

If you select one of the lower levels listed in a menu (for example, if you were to chose function 1.1 in Figure 9-11). you will move on to another menu asking you to make selections among the subelements at the next lowest level (for example, the subfunctions of Function 1.1). If there are no subelements at the lower level, the program will assume that you want to input data at the lower level and will automatically go to output (0-11).

### Abort Options

- o Select Output Entity 0-1)

### Follow-On Frames

- o Output (0-11)

Level of FUNCTION SELECT

Select FUNCTION:

-ABORT-

1.0 OPERATE SINGARS

1.1 COMMUNICATE

1.2 COMMAND AND CONTROL

1.3 MOVE

1.4 SURVIVE THREAT ENVIRONMENT

Figure 9-11. Select Level - Highest Level (0-10).

FUNCTION Selected:  
1.0 OPERATE SINGARS

Select Inclusion Option:

-ABORT-  
INCLUDE ALL LOWER FUNCTIONS  
-ONLY FUNCTIONS ONE LEVEL BELOW-  
-INCLUDE ONLY THIS FUNCTION-

Figure 9-12. Select Level - Lowest Level (0-10).

**THIS PAGE INTENTIONALLY LEFT BLANK**

## 9.11 Output (0-11)

### Description

During this frame, the data will be output on the device selected in Select Output Device (0-2). If your outputting data to a device other than your CRT screen, you'll see the phrase Printing on your screen. This phrase will remain on until the printing has been completed. If you are outputting to your CRT screen the actual output reports will replace this message. You can abort the printing by hitting Return. If you decide to abort you will return to Select Output Entity (0-1). After the data output has been completed, you will be given an option of either continuing or not continuing to output data on the entity you have selected. If you decide not to output additional data on the entity you have selected, the program will then return you to Select Output Device (0-2). If you decide not to continue with outputting with that entity, the program will return you to select Output Entity (0-1). An example of SDT output is displayed in Figure 9-13.

### Abort Options

- o Select Output Entity (0-1)

### Follow-on Frames

- o Select Output Entity (0-1)
- o Select Output Device (0-2)

COURSE DESCRIPTION

COURSE NUMBER	042-13M10
TITLE	SINGARS OPERATOR COURSE
COURSE LENGTH	16
TYPE	INDIVIDUAL
ALTERNATIVE	NORDEN
STATUS	MODIFIED
COMPARABLE COURSE	AN/TSO-38 OPERATOR COURSE
COMPARABLE NUMBER	068-79V10

COURSE NUMBER	078-79J10
TITLE	SINGARS MAINTENANCE COURSE
COURSE LENGTH	26
TYPE	INDIVIDUAL
ALTERNATIVE	NORDEN
STATUS	MODIFIED
COMPARABLE COURSE	AN/TSQ-38 MAINTENANCE COURSE
COMPARABLE NUMBER	091-23R10

-ABORT-  
-CONTINUE-

Figure 9-13. Output (0-11).

**THIS PAGE INTENTIONALLY LEFT BLANK**

## SECTION 10 - SAVE/RESTORE MODE

The Save/Restore Mode is used to (1) copy the SDT data base in your microcomputer to a floppy diskette, thereby providing you with a local hard copy of the data base or (2) copy a SDT data base which is currently on a floppy diskette back onto your microcomputer.

There are four frames in the Save/Restore Mode.

RS-1 Select Save/Restore Option. The menu sets you to either select the save or restore option.

RS-2 Insert Back-Up Diskette. This frame instructs you to insert the backup diskettes into the floppy disk drive.

RS-3 Saving This frame indicates that the data is being saved on a floppy diskette.

RS-4 Restoring This frame indicates that the data base is being restored from a floppy diskette to the microcomputer.

An overview of the logic underlying the frames in the Save/Restore mode is presented in Figure 10-1. A more detailed description of these frames is presented in the sections which follow.

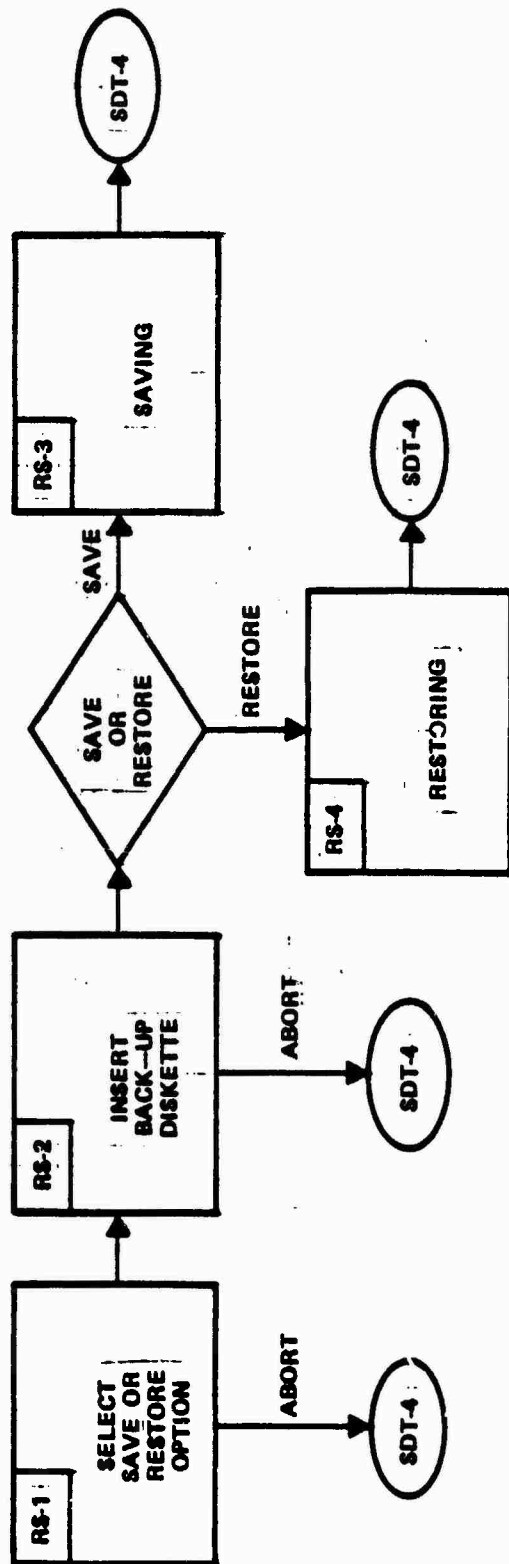

Figure 10-1 Overview of Save/Restore Mode Logic

**THIS PAGE INTENTIONALLY LEFT BLANK**

## 10.1 Select Save or Restore Option (RS-1)

### Description

This frame is used to select from two options (1) saving a local copy of a data base on a floppy disk or (2) restoring a data base from a floppy disk to your microcomputer (see Figure 10-2). To Select an option, move the cursor to the desired item and hit Return.

### Abort Options

- o Exit Correct Mode - By selecting this option you will return to the SDT Mode select (SDT-4).

### Follow-On Frames

- o Insert Backup Diskette(s) (RS-2)

SDT SAVE/RESTORE MODE

-ABORT-

-SAVE CURRENT SYSTEM TO DISKETTE-

-RESTORE OLD COPY TO DISKETTE-

Figure 10-2. Select Save or Restore Option (RS-1).

## 10.2 Insert Backup Diskette (RS-2)

### Description

During this frame, you will be instructed to insert one or more backup diskettes into the floppy disk drive (see Figure 10-3). If you are saving a data base on a floppy diskette, the computer will tell you to keep inserting diskettes into your disk drive until your entire data base has been copied. When you are later restoring this data base, you must insert the diskettes in the same order. You must only use the diskettes marked Backup-1 Backup-2, Backup-3 etc., which came with your SDT software. These diskettes have been specifically formatted for use with the SDT. Additional Backup Diskettes may be obtained at the address listed in Section 3.2.

### Abort Options

- o Abort By selecting this option, you will return to the SDT Mode Select (SDT-4)

### Follow-On Frames

- o If you selected the save option, you will go to Saving (RS-3)
- o If you selected the restore option, you will go to Restoring (RS-4)

SDT SAVE/RESTORE MODE

Please insert diskette marked: BACKUP-1  
into a disk drive (other than built-in drive).

-ABORT-  
Continue

Figure 10-3. Input Diskette (RS-2).

### 10.3 Saving (RS-3)

#### Description

This frame appears on the screen as data is being transferred from the micro to the floppy diskette. During this transfer, dots will appear on the screen. It will take approximately 30-40 seconds for one floppy diskette to be filled with data. An example of this frame is presented in Figure 10-4.

#### Abort Option

- o None.

#### Follow-On Frames

- o SDT Mode Select (SDT-4)

SDT SAVE/RESTORE MODE

Saving.....

Figure 10-4. Saving (RS-3).

## 10.4 Restoring (RS-4)

### Description

This frame appears on the screen as data is being transferred from the floppy diskette to the micro. During this transfer, dots will appear on the screen. It will take approximately 30 to 40 seconds to transfer each floppy diskette. An example of this frame is presented in Figure 10-5.

### Abort Options

- o None.

### Follow-On Frames

- o SDT Introduction (SDT-1)

SDT SAVE/RESTORE MODE

- ABORT-
- SAVE CURRENT SYSTEM TO DISKETTE-
- RESTORE OLD COPY TO DISKETTE

Restoring.....

Figure 10-5. Restoring (RS-4).

**THIS PAGE INTENTIONALLY LEFT BLANK**

## SECTION 11 - APPLICATION MODE

This mode will allow you to select and run one of the two applications program which use SDT data (see Figure 11-1). The two applications program currently in ETES are the Media Selection/Training Efficiency Program and the Resource and Cost Estimation Technique.

To select one of these programs, move the cursor to the desired option and hit Return. You will then be at the first frame for the selected program. Detailed guidance for using these two programs is provided in the User's Guide: Media Selection Program and User's Guide: Resource and Cost Estimation Technique.

SDT APPLICATIONS PROGRAM

Select Applications Program:

-Terminate Session-	(Terminate the Program)
-Return to SDT	(Return to the SDT Main Program)
<u>-Media Selection Program</u>	<u>(Perform Media Selection)</u>
-Resource and Cost Estimation Technique	(Interface with VISICALC Program)

Figure 11-1. SDT Applications Program Select (SDT-5).

## SECTION 12 - AUXILIARY MODE

This mode is used by the Data Base Director to construct a data base configuration and make software changes to the SDT. If you are not cleared for this mode, the option for selecting it will not appear on the SDT Mode Select. The average user will not be able to select this mode. An overview of the options in this mode is presented in Figure 12-1.

## SDT AUXILIARY PROGRAM

Please Select Next Program:

<u>EXIT AUXILIARY PROGRAMS</u>	(terminate the session)
SDT MAIN PROGRAM	(execute the SDT)
TEXT PRINT PROGRAM	(to print a text file)
GLOSSARY PRINT PROGRAM	(to print a glossary file)
ENTITY PRINT PROGRAM	(to print entity/attribute definitions)
SDT FILE EXAMINE PROGRAM	(an SDT file, CONFIG or glossary file)
SET CONFIGURATION FILE PROGRAM	(to modify an existing CONFIG file)
SDT FILE ALLOCATION PROGRAM	(to set initial entity sizes)
RESTORE PROFILE DISKS PROGRAM	(to create restore disks)
FORMAT TRANSFER PROGRAM	(to remove formats from one SDT to another)
BINARY/ASCII DUMP PROGRAM	(to dump and correct a file block)
FILE BLOCK COPY PROGRAM	(to copy blocks to another file)
SET GLOSSARY PROGRAM	(to set up program glossaries)
SET PROMPTS PROGRAM	(for program prompts and select forms)
ENTITY/GLOSSARY SET PROGRAM	(for entity and attribute descriptions)
CHANGE ENTITY SIZES PROGRAM	(from an existing data base with data)
ADD ATTRIBUTES PROGRAM	(from an existing data base with data)

Figure 12-1. Auxiliary Program Options.

## SECTION 13 - GUIDELINES FOR ENTERING DATA INTO THE SDT

In order to effectively enter data into an SDT data base, you must know (1) where to get the data and (2) in what sequence to enter the data. Table 13-1 is designed to provide you with guidance in both of these areas. This table lists the ETES procedure which produces each SDT data element and the specific columns of the worksheets associated with each procedure where each data element may be obtained. A detailed description of the procedure and worksheet is provided in the ETES User Guide. These procedures describe how to develop the SDT data elements.

Table 13-1 also contains sequence numbers which describe in what order the data should be entered into the SDT. The data elements with two dots beside them in Table 13-1 are key data elements which link one of the seven SDT entities to another SDT entity. An overview of the interrelationships among SDT entities is displayed in Figure 13-1. Before entering the attribute which describes the interfaces between two SDT entities both entities should be defined: More specifically the entity names and numbers (if the entity is hierarchical) should be entered into the data base then, the information describing the relationships between these two entities should be entered.

The logical structure between entities, displayed in Figure 13-1, also places limits on the generation of output reports involving two or more entities. In using the SDT you may want to get a list of all of the entities of one entity type

Table 13-1. Guidelines for Entering SDT Data.

ENTITY Function

DATA ELEMENT	RELATED ETES PROCEDURE	RELATED WORKSHEET	RELEVANT WORKSHEET COLUMNS	SEQUENCE NUMBER	COMMENTS
Number	1.1	PRF	B	1	
Name	1.1	PRF	A	1	
Collective Task Name	1.1	-	-	1	Optional
Collective Task Number					
Alternate Collective Task Number					
• Performance Goal	-	-	-	-	-
Performance Measure	1.2	PRF	C	3	
Goal/Standard Value	1.2	PRF	P	3	
• Environmental Impact	-	-	-	-	-
Environmental Variable	1.2	ENV	F	4	Optional
Variable Impacted	1.2	ENV	G	4	Optional
Reference	1.2	ENV	H	4	Optional
• Threat Impact	-	-	-	-	-
Threat Impact Variable	1.2	ENV	B	4	Optional
Variable Impacted	1.2	ENV	C	4	Optional
Reference	1.2	ENV	D	4	Optional
• Mission Impact	-	-	-	-	-
Mission Impact Variable	1.1	MIS	D	1	

• = Subentity

•• = Subentity consisting of pointers to other entities

Table 13-1. Guidelines for Entering SDT Data.

ENTITY Function

DATA ELEMENT	RELATED ETES PROCEDURE	RELATED WORKSHEET	RELEVANT WORKSHEET COLUMNS	SEQUENCE NUMBER	COMMENTS
Reference	1.1	-	-	1	Optional
•• Mission Impacted	1.1	MIS	E	1	
•• Preceding Function	1.3, 1.5	FSQ	C	6	Optional
•• Concurrent Function	1.3, 1.5	FSQ	G	6	Optional
•• Succeeding Function	1.3, 1.5	FSQ	E	6	Optional
•• Equipment	1.5	PSH	A, B, F	6	

• = Subentity

•• = Subentity consisting of pointers to other entities

Table 13-1. Guidelines for Entering SDT Data.

ENTITY Equipment

DATA ELEMENT	RELATED ETES PROCEDURE	RELATED WORKSHEET	RELEVANT WORKSHEET COLUMNS	SEQUENCE NUMBER	COMMENTS
Number	1.3, 1.6	EQP	A	7, 9	
Name	1.3, 1.6	EQP	B	7, 9	
Generic Equipment	1.3, 1.6	CEN	C	5	
Alternative	1.3, 1.6	-	-	7, 9	
FGC/WBC/WUC	1.3, 1.6	EQP	C	8, 10	Optional
Manufacturer's Part Number	1.3, 1.6	EQP	D	8, 10	Optional
MTBF	1.3, 1.6	EQP	E	8, 10	Optional
MTRR	1.3, 1.6	EQP	E	8, 10	Optional
MTBMA	1.3, 1.6	EQP	E	8, 10	Optional
Number Supported - Crew	1.3, 1.6	EQP	F	8, 10	Optional
Number Supported - ORG	1.3, 1.6	EQP	F	8, 10	Optional
Number Supported - DS	1.3, 1.6	EQP	F	8, 10	Optional
Number Supported - Depot	1.3, 1.6	EQP	F	8, 10	Optional
Display/Control Indicator	1.3, 1.6	EQP	G	8, 10	Optional
Display/Control Type	1.3, 1.6	EQP	H	8, 10	Optional
• Software Requirements	-	-	-	-	-
Software Requirements Title	1.3, 1.6	EQP	L	8, 10	Optional

• = Subentity

•• = Subentity consisting of pointers to other entities

Table 13-1. Guidelines for Entering SDT Data.

ENTITY Equipment

DATA ELEMENT	RELATED ETES PROCEDURE	RELATED WORKSHEET	RELEVANT WORKSHEET COLUMNS	SEQUENCE NUMBER	COMMENTS
• Comparable Equipment	-	-	-	-	-
Existing Equipment	1.6	-	-	9	Optional
Degree of Difference	1.6	-	-	9	Optional
• Information Input	-	-	-	-	-
Information Input Title	1.3, 1.6	EQP	J	8, 10	Optional
Equipment Source Number	1.3, 1.6	EQP	J	8, 10	Optional
• Information Output	-	-	-	-	-
Information Output Title	1.3, 1.6	EQP	K	8, 10	Optional
Equipment Source Number	1.3, 1.6	EQP	K	8, 10	Optional
Research and Development Cost					
Investment Cost					
Operating & Support Cost	1.3, 1.6	EQP	K	8, 10	Optional
Unit Price	1.3, 1.6	EQP	I	8, 10	Optional
•• Tasks					
Cost Category Five	1.3, 1.6	EQP	I	8, 10	Optional
Cost Category Six	1.3, 1.6	EQP	I	8, 10	Optional
Cost Category Seven	1.3, 1.6	EQP	I	8, 10	Optional
Cost Category Eight	1.3, 1.6	EQP	I	8, 10	Optional

• = Subentity

•• = Subentity consisting of pointers to other entities



Table 13-1. Guidelines for Entering SDT Data.

ENTITY Task

DATA ELEMENT	RELATED ETES PROCEDURE	RELATED WORKSHEET	RELEVANT WORKSHEET COLUMNS	SEQUENCE NUMBER	COMMENTS
Title	2.2 2.4	BCST NTA	K M	11 13	
• Task Numbers	-	-	-	-	-
Enlisted Task Number	2.2 2.4	BCST NTA	J L	11 13	
Officer Task Number	2.2 2.4	BCST NTA	J L	11 13	
Enlisted Task Replacement	2.2 2.4	-	-	11 13	Optional
Officer Replacement Number	2.2 2.4	-	-	11 13	Optional
Additional Task Number	2.2 2.4	-	-	11 13	Optional
Type	2.2 2.4	-	-	11 13	Optional
Status	2.2 2.4	-	-	11 13	Optional
Work Area	3.3	-	-	16	Optional
Task Area	3.3	-	-	16	Optional
Amount of Supervision	3.3	-	-	16	Optional
Number Performing	3.3	-	-	16	Optional
• Frequency/Duration Measure	-	-	-	-	-
Frequency	3.3	-	-	16	Optional
Frequency Measurement Base	3.3	-	-	16	Optional
Duration (Manhours)	3.3	-	-	16	Optional
Elapsed Time Estimated	3.3	-	-	16	Optional

- = Subentity
- = Subentity consisting of pointers to other entities

Table 13-1. Guidelines for Entering SDT Data.

ENTITY Task

DATA ELEMENT	RELATED ETES PROCEDURE	RELATED WORKSHEET	RELEVANT WORKSHEET COLUMNS	SEQUENCE NUMBER	COMMENTS
Elapsed Time Predicted	3.3	-	-	16	Optional
Elapsed Time Measured	3.3	-	-	16	Optional
Elapsed Measurement Base	3.3	-	-	16	Optional
• Training Assignments	-	-	-	-	-
Initial Training Assign. Type	3.2	SUMSET	C	15	
Qualif. Training Assign. Type	3.2	SUMSET	D	15	Optional
Additional Assign. Type	3.2	-	-	15	Optional
Training Assignments	3.2			15	
Preceding Tasks	3.3	-	-	16	Optional
Succeeding Tasks	3.3	-	-	16	Optional
• Task Element	-	-	-	-	-
Element Title	3.3	-	-	16	Optional
• Task Condition	-	-	-	-	-
Condition Title	2.2 2.4	BCST NTA	M O	11 13	
• Task Standard	-	-	-	-	-
Task Standard Measure	2.2 2.4	BCST NTA	N P	11 13	
Amount/Value	2.2 2.4	BCST NTA	N P	11 13	

• = Subentity

•• = Subentity consisting of pointers to other entities

Table 13-1. Guidelines for Entering SDT Data.

ENTITY Task

DATA ELEMENT	RELATED ETES PROCEDURE	RELATED WORKSHEET	RELEVANT WORKSHEET COLUMNS	SEQUENCE NUMBER	COMMENTS
• Training Emphasis Scales	-	-	-	-	-
Percent Performing	3.2	SUMSET	B	15	COLUMNS VARY ACROSS WORKSHEET
Percent Time Performing	3.2	SUMSET	B	15	COLUMNS VARY ACROSS WORKSHEET
Conseq. Inadequate Performance	3.2	SUMSET	B	15	COLUMNS VARY ACROSS WORKSHEET
Task Delay Tolerance	3.2	SUMSET	B	15	COLUMNS VARY ACROSS WORKSHEET
Task Learning Difficulty	3.2	SUMSET	B	15	COLUMNS VARY ACROSS WORKSHEET
Prob. Defic. Performance	3.2	SUMSET	B	15	COLUMNS VARY ACROSS WORKSHEET
Time from Entry to Performance	3.2	SUMSET	B	15	COLUMNS VARY ACROSS WORKSHEET
• Method Variables	-	-	-	-	-
Task Role	3.6			18	
Activity Performed	3.6	-	-	18	Optional
Stability of Activity	3.6	-	-	18	Optional
Physical Context	3.6	-	-	18	Optional
Psychological Impact	3.6	-	-	18	Optional
Task Characteristic One	3.3	-	-	16	Optional
Task Characteristic Two	3.3	-	-	16	Optional
Task Characteristic Three	3.3	-	-	16	Optional

• = Subentity

•• = Subentity consisting of pointers to other entities

Table 13-1. Guidelines for Entering SDT Data.

ENTITY Task

DATA ELEMENT	RELATED ETES PROCEDURE	RELATED WORKSHEET	RELEVANT WORKSHEET COLUMNS	SEQUENCE NUMBER	COMMENTS
Task Characteristic Four	3.3	-	-	16	Optional
Task Characteristic Five	3.3	-	-	16	Optional
Task Characteristic Six	3.3	-	-	16	Optional
Task Characteristic Seven	3.3	-	-	16	Optional
Task Characteristic Eight	3.3	-	-	16	Optional
Task Characteristic Nine	3.3	-	-	16	Optional
Task Characteristic Ten	3.3	-	-	16	Optional
Task Characteristic Eleven	3.3	-	-	16	Optional
Task Characteristic Twelve	3.3	-	-	16	Optional

• = Subentity  
 •• = Subentity consisting of pointers to other entities

Table 13-1. Guidelines for Entering SDT Data.

ENTITY Task

DATA ELEMENT	RELATED ETES PROCEDURE	RELATED WORKSHEET	RELEVANT WORKSHEET COLUMNS	SEQUENCE NUMBER	COMMENTS
• Initiating Cues	-	-	-	-	-
Initiating Cue Title	3.3	-	-	16	Optional
Related Equipment Number	3.3	-	-	16	Optional
• Terminating Cues	-	-	-	-	-
Terminating Cue Title	3.3	-	-	16	Optional
Related Equipment Number	3.3	-	-	16	Optional
• Tools/Test Equipment	-	-	-	-	-
Title	3.3	-	-	16	Optional
Tools/Test Equipment Number	3.3	-	-	16	Optional
Tool/Test Equipment Indicator	3.3	-	-	16	Optional
• Failure Modes	-	-	-	-	-
Failure Mode	3.3	-	-	-	16
Percent of Failures	3.3	-	-	-	16
• Skills & Knowledges	-	-	-	-	-
Title	3.3	Skill	C, E	16	

• = Subentity

•• = Subentity consisting of pointers to other entities

Table 13-1. Guidelines for Entering SDT Data.

ENTITY Task

DATA ELEMENT	RELATED ETES PROCEDURE	RELATED WORKSHEET	RELEVANT WORKSHEET COLUMNS	SEQUENCE NUMBER	COMMENTS
Type	3.3	-	-	16	Optional
Category	3.3	-	-	16	Optional
Characteristic One	3.3	-	-	16	Optional
Characteristic Two	3.3	-	-	16	Optional
Characteristic Three	3.3	-	-	16	Optional
Characteristic Four	3.3	-	-	16	Optional
Characteristic Five	3.3	-	-	16	Optional
Characteristic Six	3.3	-	-	16	Optional
• Learning Objectives	-	-	-	-	-
Learning Objective	3.3	-	-	16	Optional
Characteristic One	3.3	-	-	16	Optional
Characteristic Two	3.3	-	-	16	Optional
Characteristic Three	3.3	-	-	16	Optional
Characteristic Four	3.3	-	-	16	Optional
• Performance Measures	-	-	-	-	-
Performance Measure	3.3	-	-	16	Optional
Amount/Value	3.3	-	-	16	Optional

• = Subentity

•• = Subentity consisting of pointers to other entities

Table 13-1. Guidelines for Entering SDT Data.

ENTITY Task

DATA ELEMENT	RELATED ETES PROCEDURE	RELATED WORKSHEET	RELEVANT WORKSHEET COLUMNS	SEQUENCE NUMBER	COMMENTS
• Stimuli	-	-	-	-	-
Medium	3.7	PSYCRIT	A	19	
Visual Form	3.7	PSYCRIT	A	19	
Visual Movement	3.7	PSYCRIT	A	19	
Visual Spectrum	3.7	PSYCRIT	A	19	
Visual Scale	3.7	PSYCRIT	A	19	
Visual Contrast	3.7	PSYCRIT	A	19	
Audio Sources	3.7	PSYCRIT	A	19	
Audio Stimuli Intensity	3.7	PSYCRIT	A	19	
Stimuli Presentation	3.7	PSYCRIT	A	19	
Stimuli Presentation Rate	3.7	PSYCRIT	A	19	
Number of Channels	3.7	PSYCRIT	A	19	
Stimuli Distribution	3.7	PSYCRIT	A	19	
• Responses	-	-	-	-	-
Response Mode	3.7	PSYCRIT	B	19	
Intensity of Response	3.7	PSYCRIT	B	19	
Response Implementation	3.7	PSYCRIT	B	19	

• = Subentity

•• = Subentity consisting of pointers to other entities

Table 13-1. Guidelines for Entering SDT Data.

ENTITY Task

DATA ELEMENT	RELATED ETES PROCEDURE	RELATED WORKSHEET	RELEVANT WORKSHEET COLUMNS	SEQUENCE NUMBER	COMMENTS
Required Response Rate	3.7	PSYCRIT	B	19	
No. Response Channels	3.7	PSYCRIT	B	19	
Response Distribution	3.7	PSYCRIT	B	19	
• Feedbacks	-	-	-	-	-
Feedback Medium	3.7	PSYCRIT	C	19	
Feedback Source	3.7	PSYCRIT	C	19	
Feedback Type	3.7	PSYCRIT	C	19	
Feedback Distribution	3.7	PSYCRIT	C	19	

• = Subentity  
 .. = Subentity consisting of pointers to other entities

Table 13-1. Guidelines for Entering SDT Data.

ENTITY Course

DATA ELEMENT	RELATED ETES PROCEDURE	RELATED WORKSHEET	RELEVANT WORKSHEET COLUMNS	SEQUENCE NUMBER	COMMENTS
Title	3.6	QPOI-1	TOP	17	
Course Number	3.6	QPOI-1	TOP	17	
Course Length	3.6	QPOI-1	TOP	17	
Type	3.6	QPOI-1	TOP	17	
Alternative	3.6	-	-	17	Optional
Status	3.6	QPOI-1	-	17	
Comparable Course	3.6	CMOD	TOP	17	
Comparable Number	3.6	CMOD	TOP	17	
•• Prerequisite Courses	3.8	PATH	A	20	
•• Follow-on Courses	3.8	PATH	B	20	
Attrition Rate	4.1	OPSP	TOP	21	
Maximum Class Size	4.1	DPSP	TOP	21	
Class Frequency	4.1	OPSP	TOP	21	
• Resource Requirements	-	-	-	-	-
No. Norm Graduates	4.2	OPSP	B	22	
Quarters/Mess Available	4.1	-	-	21	Optional
Percent Officer Graduates	4.1	-	-	21	Optional

• = Subentity

•• = Subentity consisting of pointers to other entities

Table 13-1. Guidelines for Entering SDT Data.

ENTITY Course

DATA ELEMENT	RELATED ETES PROCEDURE	RELATED WORKSHEET	RELEVANT WORKSHEET COLUMNS	SEQUENCE NUMBER	COMMENTS
Percent TDY-Status Grads	4.1	-	-	21	Optional
ICH Per Class	4.3	-	-	23	Media Selectio Program
Number of Instructors	4.3	NINS	B	23	
Man-Days P8 Troop Support	4.6	-	-	24	
Man-Days P2/3 Support	4.6	-	-	24	
• Course Costs	-	-	-	-	-
Instructional Dept (OMA)	5.1	-	-	25	RCET
Instructional Dept (MPA)	5.1	-	-	25	RCET
Flying Hour Cost/Student	5.1	-	-	25	RCET
Direct Mission Other (OMA)	5.1	-	-	25	RCET
Direct Mission Other (MPA)	5.1	-	-	25	RCET
P8 Troop Support (OMA)	5.1	-	-	25	RCET
P8 Troop Support (MPA)	5.1	-	-	25	RCET
P8 Troop Support (PA)	5.1	-	-	25	RCET
P2/3 Troop Support (OMA)	5.1	-	-	25	RCET
P2/3 Troop Support (MPA)	5.1	-	-	25	RCET
P2/3 Troop Support (FHMA)	5.1	-	-	25	RCET

• = Subentity

•• = Subentity consisting of pointers to other entities

Table 13-1. Guidelines for Entering SDT Data.

ENTITY Course

DATA ELEMENT	RELATED ETES PROCEDURE	RELATED WORKSHEET	RELEVANT WORKSHEET COLUMNS	SEQUENCE NUMBER	COMMENTS
Ammunition Cost/Student	5.1	-	-	25	RCET
Equipment Deprec. Per Grad	5.1	-	-	25	RCET
Travel Pay to Course (OMA)	5.1	-	-	25	RCET
Travel Pay to Course (MPA)	5.1	-	-	25	RCET
Base Operations (OMA)	5.1	-	-	25	RCET
Base Operations (MPA)	5.1	-	-	25	RCET
Training Aids (OMA)	5.4	-	-	25	RCET
Training Aids (MPA)	5.1	-	-	25	RCET
Other Support Costs (OMA)	5.1	-	-	25	RCET
Other Support Costs (MPA)	5.1	-	-	25	RCET
Average Cost Per Graduate	5.1	-	-	25	RCET
• Student Input Requirements	-	-	-	-	-
Start Year	4.1	OPSP	C	21	
Location Year	4.1	OPSP	A	21	
# Students Year One	4.2	NSTUD	C	22	
# Students Year Two	4.2	NSTUD	D	22	
# Students Year Three	4.2	NSTUD	E	22	

• = Subentity

•• = Subentity consisting of pointers to other entities

Table 13-1. Guidelines for Entering SDT Data.

ENTITY Course

DATA ELEMENT	RELATED ETES PROCEDURE	RELATED WORKSHEET	RELEVANT WORKSHEET COLUMNS	SEQUENCE NUMBER	COMMENT
# Students Year Four	4.1	OPSP	F	22	
# Students Year Five	4.1	OPSP	G	22	
# Students Steady State	4.1	OPSP	B	22	
Location Two	4.1	OPSP	A	21	
# Students Year One	4.2	OPSP	C	22	
# Students Year Two	4.2	OPSP	D	22	
# Students Year Three	4.2	OPSP	E	22	
# Students Year Four	4.2	OPSP	F	22	
# Students Year Five	4.2	OPSP	G	22	
# Students Steady State	4.2	OPSP	B	22	
Location Three	4.1	OPSP	A	21	
# Students Year One	4.2	OPSP	C	22	
# Students Year Two	4.2	OPSP	D	22	
# Students Year Three	4.2	OPSP	E	22	
# Students Year Four	4.2	OPSP	F	22	
# Students Year Five	4.2	OPSP	G	22	
# Students Steady State	4.2	OPSP	B	22	

- = Subentity
- = Subentity consisting of pointers to other entities

Table 13-1. Guidelines for Entering SDT Data.

ENTITY Course

DATA ELEMENT	RELATED ETES PROCEDURE	RELATED WORKSHEET	RELEVANT WORKSHEET COLUMNS	SEQUENCE NUMBER	COMMENTS
Location Four	4.1	OPSP	A	21	
# Students Year One	4.2	OPSP	C	22	
# Students Year Two	4.2	OPSP	D	22	
# Students Year Three	4.2	OPSP	E	22	
# Students Year Four	4.2	OPSP	F	22	
# Students Year Five	4.2	OPSP	G	22	
# Students Steady State	4.2	OPSP	B	22	
• Module	-	-	-	-	-
Title	3.6	QPOI-1	A	18	
Length	3.6	QPOI-1	B	18	
Alternative	3.6	-	-	18	Optional
•• Tasks	3.6	QPOI-2	A	18	
Instructional Method 1	3.6	QPOI-1	C	18	
Student/Instructor Ratio	4.1	QPOI-1	C	21	
Contact Hours	3.6	QPOI-1	C	18	
Media	3.7	MSEC	B,C	19	
Instructional Method 2	3.6	QPOI-1	D	18	

• = Subentity

•• = Subentity consisting of pointers to other entities

Table 13-1. Guidelines for Entering SDT Data.

ENTITY Course

DATA ELEMENT	RELATED ETES PROCEDURE	RELATED WORKSHEET	RELEVANT WORKSHEET COLUMNS	SEQUENCE NUMBER	COMMENTS
Student/Instructor Ratio	4.1	QPOI-1	D	21	
Contact Hours	3.6	QPOI-1	D	18	
Media	3.7	MSEC	B, C	19	
Instructional Method 3	3.6	QPOI-1	E	18	
Student/Instructor Ratio	4.1	QPOI-1	E	21	
Contact Hours	3.6	QPOI-1	E	18	
Media	3.7	MSEC	B, C	19	
Instructional Method 4	3.6	QPOI-1	F	18	
Student/Instructor Ratio	4.1	QPOI-1	F	21	
Contact Hours	3.6	QPOI-1	F	18	
Media	3.7	MSEC	B, C	19	
Instructional Method 5	3.6	QPOI-1	G	18	
Student/Instructor Ratio	4.1	QPOI-1	G	21	
Contact Hours	3.6	QPOI-1	G	18	
Media	3.7	MSEC	B, C	19	
Instructional Method 6					
Student/Instructor Ratio					

. = Subentity

.. = Subentity consisting of pointers to other entities

Table 13-1. Guidelines for Entering SDT Data.

ENTITY Duty Position

DATA ELEMENT	RELATED ETES PROCEDURE	RELATED WORKSHEET	RELEVANT WORKSHEET COLUMNS	SEQUENCE NUMBER	COMMENTS
Duty Position Title	2.3	BCST	L	12	
	2.5	NTA	N	14	
Duty Position Number	2.3	-	-	12	
	2.5			14	
MOS Title	2.3	BCST	N	12	
	2.5	NTA	P	14	
MOS Number	2.3	BCST	N	12	
	2.5	NTA	P	14	
ASI Title	2.3	-	-	12	
	2.5			14	Optional
ASI Number	2.3	-	-	12	
	2.5			14	Optional
Skill Level	2.3	BCST	M	12	
	2.5	NTA	O	14	
Position Type	2.3	-	-	12	
	2.5			14	Optional
• Manpower Requirements	-	-	-	-	-
Start Date	4.2	NSSS	B	22	
Manpower Reqts. - Yr 1	4.2	NSSS	B	22	
Manpower Reqts. - Yr 2	4.2	NSSS	B	22	
Manpower Reqts. - Yr 3	4.2	NSSS	B	22	
Manpower Reqts. - Yr 4	4.2	NSSS	B	22	
Manpower Reqts. - Yr 5	4.2	NSSS	B	22	
Manpower Reqts. - Yr 6	4.2	NSSS	B	22	
Manpower Reqts. - Yr 7	4.2	NSSS	B	22	

• = Subentity

•• = Subentity consisting of pointers to other entities

Table 13-1. Guidelines for Entering SDT Data.

ENTITY Duty Position

DATA ELEMENT	RELATED ETES PROCEDURE	RELATED WORKSHEET	RELEVANT WORKSHEET COLUMNS	SEQUENCE NUMBER	COMMENTS
•• Tasks	2.3	BCST	K, L	12	-
	2.5	NTA	M, N	14	
Organization One Number	2.3	-	-	12	Optional
	2.5			14	
Organization One Title	2.3	-	-	12	Optional
	2.5			14	
Organization Two Number	2.3	-	-	12	Optional
	2.5			14	
Organization Two Title	2.3	-	-	12	Optional
	2.5			14	
Organization Three Number	2.3	-	-	12	Optional
	2.5			14	
Organization Three Title	2.3	-	-	12	Optional
	2.5			14	
Organization Four Number	2.3	-	-	12	Optional
	2.5			14	
Organization Four Title	2.3	-	-	12	Optional
	2.5			14	

• = Subentity  
 •• = Subentity consisting of pointers to other entities

Table 13-1. Guidelines for Entering SDT Data.

ENTITY Media

DATA ELEMENT	RELATED ETES PROCEDURE	RELATED WORKSHEET	RELEVANT WORKSHEET COLUMNS	SEQUENCE NUMBER	COMMENTS
Title	3.7	MSEC	B, C	19	
Alternative	3.7	-	-	19	Optional
Number	3.7	-	-	19	Optional
Alternative Number	3.7	-	-	19	Optional
Issue Rate Per Student	4.1	MUS	B	21	
Publication Date	3.7	-	-	19	Optional
Revision Date	3.7	-	-	19	Optional
Development Cost	5.1	-	-	25	Optional
Investment Cost	5.1	-	-	25	Optional
Operating & Support Cost	5.1	-	-	25	Optional
Unit Price	5.1	-	-	25	Optional
Cost Category Six	5.1	-	-	25	Optional
Cost Category Seven	5.1	-	-	25	Optional
Cost Category Eight	5.1	-	-	25	Optional
Cost Category Nine	5.1	-	-	25	Optional
Cost Category Ten	5.1	-	-	25	Optional
Cost Category Eleven	5.1	-	-	25	Optional

• = Subentity

•• = Subentity consisting of pointers to other entities

Table 13-1. Guidelines for Entering SDT Data.

ENTITY Media

DATA ELEMENT	RELATED ETES PROCEDURE	RELATED WORKSHEET	RELEVANT WORKSHEET COLUMNS	SEQUENCE NUMBER	COMMENTS
Cost Category Twelve	5.1	-	-	25	Optional
Specify Type	3.7	MSEC	B	19	
Max Daily Oper Time	4.1	-	-	21	Optional
Student/Instructor Ratio	4.1	MUS	B	21	
Number of Media - Yr 1	4.5 4.6	DEEQ MEDSUM	C	24	
Number of Media - Yr 2	4.5 4.6	DEEQ MEDSUM	D	24	
Number of Media - Yr 3	4.5 4.6	DEEQ MEDSUM	E	24	
Number of Media - Yr 4	4.5 4.6	DEEQ MEDSUM	F	24	
Number of Media - Yr 5	4.5 4.6	DEEQ MEDSUM	G	24	
Number of Media - Yr 6	4.5 4.6	-	-	24	Optional Optional
Number of Media - Yr 7	4.5 4.6	-	-	24	
Number of Media - Steady State	4.5 4.6	DEEQ MEDSUM	B	24	
Index of Effectiveness	6.1	TVICE	D	26	Output from Trainvice
Overall Index of Effectiveness	6.1	TVICE	F	26	Output from Trainvice
Index of Personnel Reqts.	6.1	TVICE	E	26	Output from Trainvice

• = Subentity

•• = Subentity consisting of pointers to other entities

Table 13-1. Guidelines for Entering SDT Data.

ENTITY Mission

DATA ELEMENT	RELATED ETES PROCEDURE	RELATED WORKSHEET	RELEVANT WORKSHEET COLUMNS	SEQUENCE NUMBER	COMMENTS
Name	1.1	MIS	A	2	
Percent Operating Time	1.1	MIS	G	2	
Annual # Missions	1.1	MIS	H	2	
Annual Operating Days	1.1	MIS	I	2	
Mean Duration	1.1	MIS	J	2	
Measurement Base	1.1	MIS	J	2	
Annual Oper. Days Req'd.	1.1	MIS	K	2	

- = Subentity
- = Subentity consisting of pointers to other entities

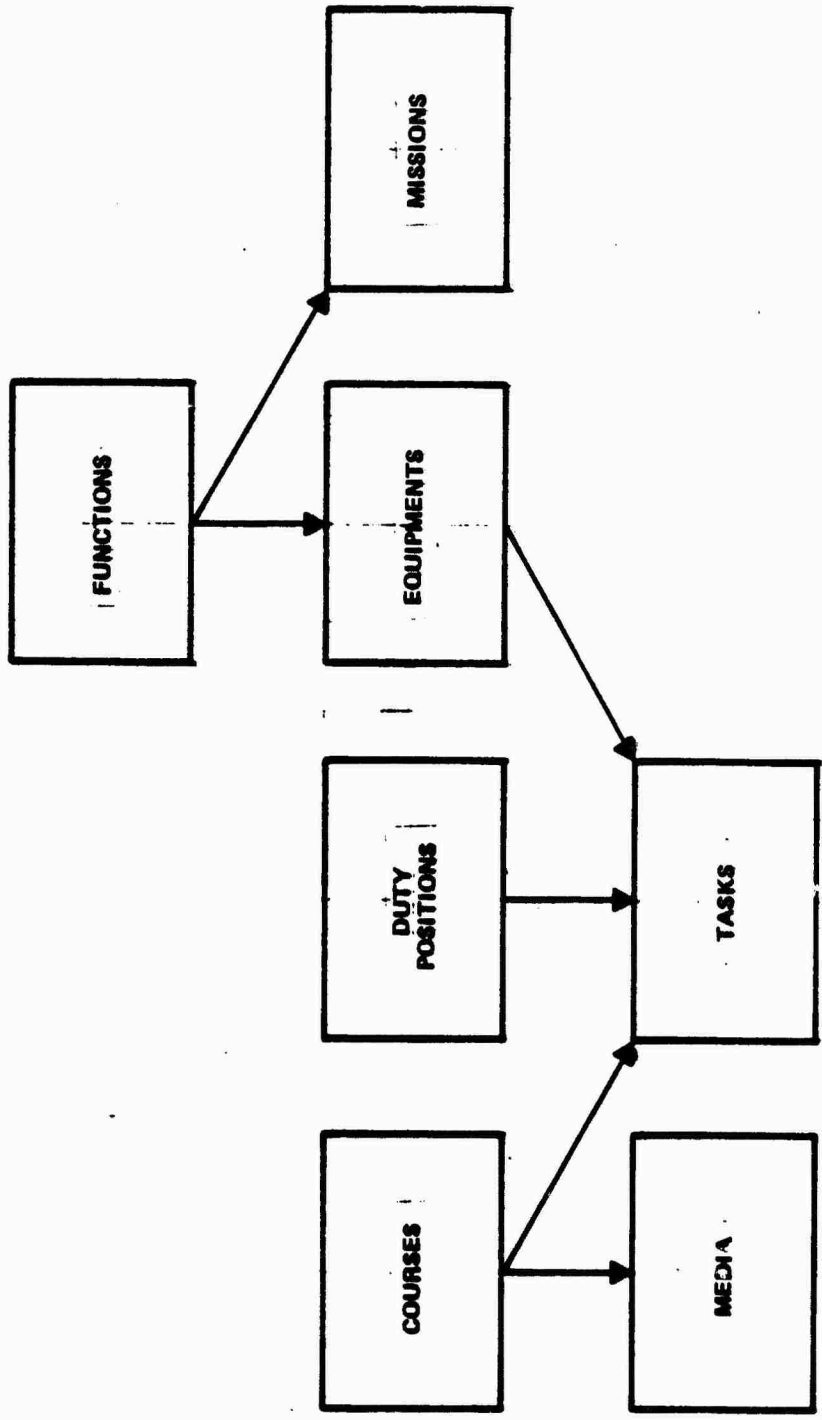

Figure 13-1 Overview of Hierarchical Relationships Among SDT Entities

associated with all of the entities of another type. For example, you may want to get a listing of all of the tasks associated with equipments. In generating reports which involve more than one entity type, the following restrictions apply.

- o You may only get a listing of entity A by entity B if entity B is lower in the SDT hierarchical structure than entity A. The direction of the hierarchical structure is indicated in Figure 13-1. To simplify things, Table 13-2 provides a listing of the types of acceptable output reports.
- o When using an output report which involves three entities, such as Tasks by Equipments by Function, the only attributes of the third entity which may appear in the report is the entity name and number. For example, in the Tasks by Equipments by Function report only the task names and no other task attributes may appear in the report.

As outlined in the procedures listed in ETES User Guide, you should set up at least two data bases for each weapon system you are dealing with: one data base describing the Baseline Comparison System (BCS) and another data base describing the New System. You may also want to set up a third data base for the Predecessor system.

If there are entities or attributes which are not currently in the SDT data base which you would like to work with, you should present this information to the SDT Data Base

Table 13-2. Types of Acceptable Reports  
Involving Two or More Entities

- Equipments by Function
- Missions by Function
- Tasks by Equipments by Function
- Tasks by Equipments
- Tasks by Duty Positions
- Tasks by Courses
- Media by Courses

Directory. It is relatively easy to add additional entities or attributes to the SDT to meet the special needs of individual users.

**THIS PAGE INTENTIONALLY LEFT BLANK**

## APPENDIX A: SDT STRUCTURE

The SDT is a hierarchically structured data base. This appendix (a) describes the hierarchical relationships among data elements, and (2) provides a detailed description of each SDT data element.

Figure A-1 displays the hierarchical structure among SDT entities. Table A-1 displays the hierarchical structure among the subentities and attributes within each of these entities. A definition for each data element in the SDT is provided in Table A-1, which is the SDT data dictionary.

This data dictionary describes (1) the data element name, (2) glossary definition for the element (this is the same definition accessed by hitting the ESCAPE key), (3) the maximum possible character length of the data element, and (4), for subentities, the maximum number of subentities which may be used.

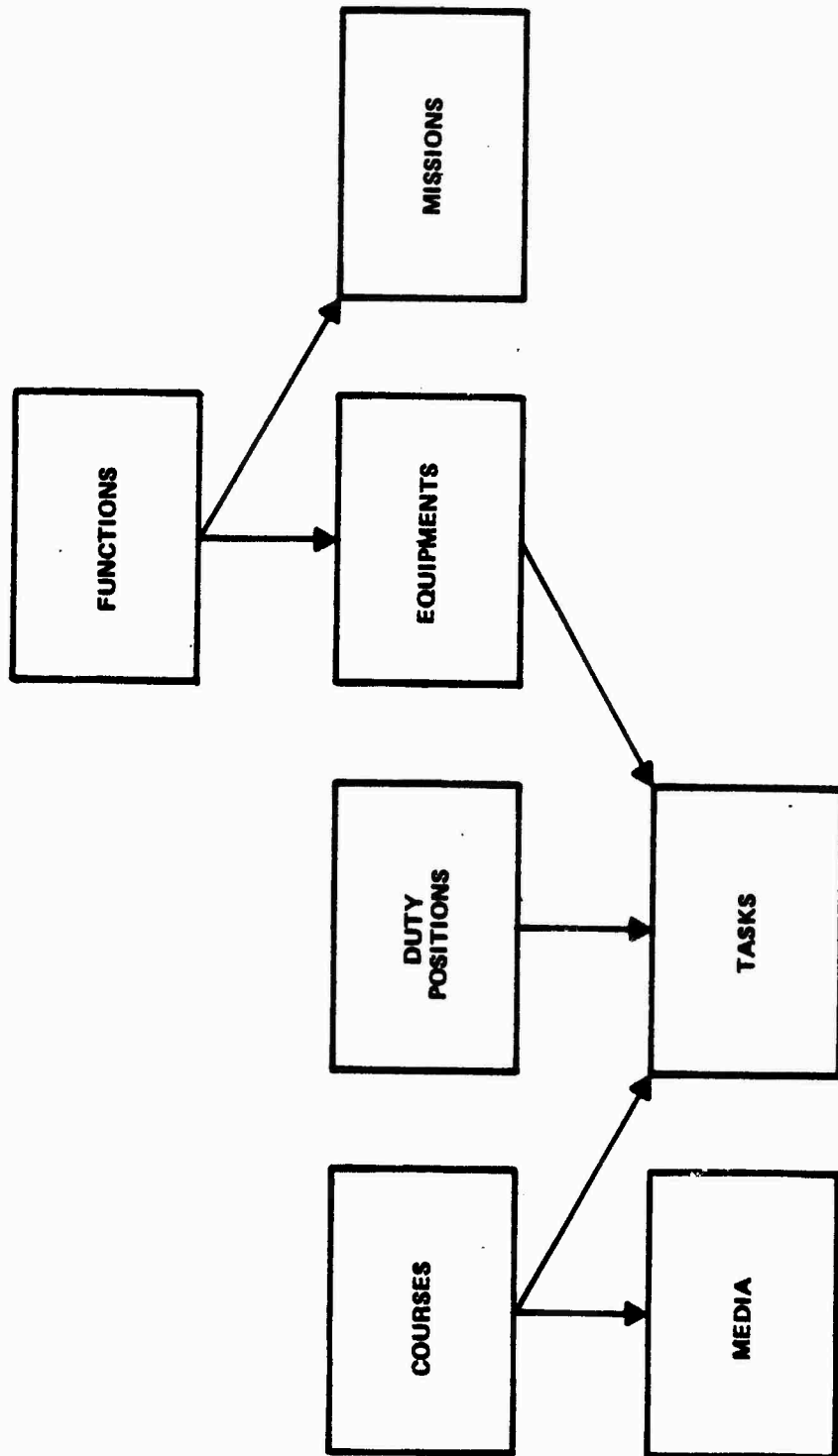

Figure A-1 Overview of Hierarchical Relationships Among SDT Elements

**TABLE A-1**

**SDT DATA DICTIONARY**



FUNCTION Attribute  
-----Glossary Definition...  
-----

- 6) PERFORMANCE GOAL  
Sub-Entity refers to:  
Perform. Goal  
(No Limit)
- PERFORMANCE GOAL- A description of the capabilities which must be achieved under a specific Function.  
This attribute is a sub-entity. There may be any number of performance measures per function.
- 7) ENVIRONMENTAL IMPACT  
Sub-Entity refers to:  
Envir. Impact  
(No Limit)
- ENVIRONMENTAL IMPACT- A brief description of those features of the natural geography which are likely to have major impacts on the capability of a system to perform its functions. These features include terrain, weather (for example snow, sleet), climate, and environmental conditions (dust level, noise level, oxygen level).  
This attribute is a sub-entity. There may be any number per function.
- 8) THREAT IMPACT  
Sub-Entity refers to:  
Threat Impact  
(No Limit)
- THREAT IMPACT- A brief description of those features of the threat that are likely to have major impacts on the capability of a system to perform its function. These features include type of threat, threat density, etc.  
This attribute is a sub-entity. There may be any number of threat impacts per function.
- 9) MISSION IMPACT  
Sub-Entity refers to:  
Mission Impact  
(No Limit)
- MISSION IMPACT- A brief description of the major features of a function which are impacted by alternative missions.  
This attribute is a sub-entity. There may be any number of mission impacts per function.
- 10) PRECEDING FUNCTION  
Sub-Entity refers to:  
FUNCTION  
(Limit of 6)
- PRECEDING FUNCTION- Function(s) which must be performed before the designated function can be performed if successful system performance is to be achieved.  
This attribute is another function entity. There may be as many as 6 of these attributes per function.
- 11) CONCURRENT FUNCTION  
Sub-Entity refers to:  
FUNCTION  
(Limit of 6)
- CONCURRENT FUNCTION- Functions occurring at the same time as the designated function during successful system performance.  
This attribute is another function entity. There may be as many as 6 of these attributes per function.
- 12) SUCCEEDING FUNCTION  
Sub-Entity refers to:  
FUNCTION  
(Limit of 6)
- SUCCEEDING FUNCTION- Function(s) which must be performed after a designated function if successful mission performance is to be achieved.  
This attribute is another function entity. There may be as many as 6 of these attributes per function.

FUNCTION Attribute  
-----

13) EQUIPMENT  
    Sub-Entity refers to:  
    EQUIPMENT  
    (Limit of 8)

Glossary Definition...  
-----

EQUIPMENT- A list of the specific equipments which will be used in performing a specific function.  
This attribute is an equipment entity. There may be as many as 8 of these attributes per function.



```

*****
Entity Name      Nbr Type      Glossary Definition...
-----
Envir. Impact   3 Sub-Entity
ENVIRONMENTAL IMPACT- A brief description of those features of the natural
geography which are likely to have major impacts on the capability of a
system to perform its functions. These features include terrain, weather
(for example snow, sleet), climate, and environmental conditions (dust
level, noise level, oxygen level).
*****

```

```

Envir. Impact Attribute      Glossary Definition...
-----

```

```

1) ENVIRONMENTAL VARIABLE
Character String
39 Characters

ENVIRONMENTAL VARIABLE- A variable related to natural geography which might
have a major impact on the performance of a system function. Examples of
the types of variables included under this category include terrain, weather
(snow, sleet), climate, and environmental conditions (dust level, noise
level, oxygen level)
39 characters

```

```

2) VARIABLE IMPACTED
Character String
25 Characters

VARIABLE IMPACTED- The features of a function which are influenced of
altered by environmental impacts.
25 characters

```

```

3) REFERENCE
Character String
15 Characters

REFERENCE- Source used to document the projected environmental impact.
15 characters

```

\*\*\*\*\*

Entity Name	Nbr Type	Glossary Definition...
Threat Impact	4 Sub-Entity	THREAT IMPACT- A brief description of those features of the threat that are likely to have major impacts on the capability of a system to perform its function. These features include type of threat, threat density, etc.

\*\*\*\*\*

Threat Impact Attribute -----  
Glossary Definition...-----

1) THREAT IMPACT VARIABLE  
Character String  
39 Characters

THREAT IMPACT VARIABLE- A variable used to describe those aspects of the threat which can directly impact system functions.  
For example, type of threat, threat density, threat location.  
39 characters

2) VARIABLE IMPACTED  
Character String  
25 Characters

VARIABLE IMPACTED- The features of a function which are influenced or altered by a threat variable.  
25 characters

3) REFERENCE  
Character String  
15 Characters

REFERENCE- Source used to document the projected threat impact.  
15 characters

```

*****
Entity Name      Mbr Type      Glossary Definition...
-----
Mission Impact   5 Sub-Entity  MISSION IMPACT- A brief description of the major features of a
*****          *****          function which are impacted by alternative MISSIONS.
*****

```

-----  
Mission Impact Attribute -----  
-----

1) MISSION IMPACT VARIABLE  
Character String  
39 Characters

MISSION IMPACT VARIABLE- Those aspects of a function which vary across  
missions.  
39 characters

2) REFERENCE  
Character String  
15 Characters

REFERENCE- Source used to document the projected mission impact.  
15 characters

3) MISSIONS IMPACTED  
Sub-Entity refers to:  
MISSION  
(Limit of 4)

MISSIONS IMPACTED- Those system missions which are influenced by the  
mission impact variables.  
This attribute is a mission entity. There may be as  
many as 4 missions per Mission Impact.



## EQUIPMENT Attribute

## Glossary Definition...

- 7) MTBF  
 Decimal Value  
 width=8 places=2
- MTBF- Mean time between failures. For a particular interval, the total functional life of a population of an item divided by the total number of failures within the population during the measurement interval. The definition holds for time, rounds, miles, events, or other measures of life units. (DARCOM-P 750-16)  
 7 digits, 2 decimal places
- 8) MTR  
 Decimal Value  
 width=8 places=2
- MTR- Mean Time to Repair. The total corrective maintenance time divided by the total number of corrective maintenance actions during a given period of time. (DARCOM-P 750-16)  
 7 digits, 2 decimal places
- 9) MTBMA  
 Decimal Value  
 width=8 places=2
- MTBMA- Mean Time Between Maintenance Actions. The mean of the distribution of the time intervals between maintenance actions, either preventive, corrective, or both.  
 7 digits, 2 decimal places
- 10) NUMBER SUPPORTED - CREW  
 Integer Value  
 from 0 to 10000
- NUMBER SUPPORTED - CREW: the number of systems which can be supported, repaired, and/or maintained at the crew level of maintenance.
- 11) NUMBER SUPPORTED - ORG  
 Integer Value  
 from 0 to 10000
- NUMBER SUPPORTED - ORG: the number of systems which can be supported, repaired, maintained at the organizational level of maintenance.
- 12) NUMBER SUPPORTED - DS  
 Integer Value  
 from 0 to 10000
- NUMBER SUPPORTED - DS: the number of systems which can be supported, repaired, maintained at the direct support level of maintenance.
- 13) NUMBER SUPPORTED - DEPOT  
 Integer Value  
 from 0 to 10000
- NUMBER SUPPORTED- DEPOT: the number of systems which can be supported, repaired, maintained at the depot level of maintenance.

**EQUIPMENT Attribute**

**Glossary Definition...**

**14) DISPLAY/CONTROL INDICATOR**  
 Select from List  
 number 9

**DISPLAY/CONTROL INDICATOR-** A variable used to indicate whether a particular piece of equipment is either (1) a display or (2) a control mechanism.

**15) DISPLAY/CONTROL TYPE**  
 Character String  
 10 Characters

**DISPLAY/CONTROL TYPE-** Type of display or type of control.  
 10 characters

**16) SOFTWARE REQUIREMENTS**  
 Sub-Entity refers to:  
 Software Requirements  
 (No Limit)

**SOFTWARE REQUIREMENTS-** A listing of the functions performed by the software associated with a particular piece of equipment. This attribute is a sub-entity. There may be any number of software requirements per equipment.

**17) COMPARABLE EQUIPMENT**  
 Sub-Entity refers to:  
 Comparable Equip.  
 (No Limit)

**COMPARABLE EQUIPMENT-** A description of the existing equipment which is comparable (similar) in both type and function to the projected equipment. This attribute is a sub-entity. There may be any number of comparable equipments per equipment.

**18) INFORMATION INPUT**  
 Sub-Entity refers to:  
 Information Input  
 (No Limit)

**INFORMATION INPUT-** A description of the information elements which the hardware/software configuration must have to perform its function. This attribute is a sub-entity. There may be any number of information inputs per equipment.

**19) INFORMATION OUTPUT**  
 Sub-Entity refers to:  
 Information Output  
 (No Limit)

**INFORMATION OUTPUT-** A description of the information produced by a specific equipment hardware/software configuration. This attribute is a sub-entity. There may be any number of information outputs per equipment.

**20) RESEARCH & DEVELOPMENT COST**  
 Decimal Value  
 width=8 places=2

**RESEARCH & DEVELOPMENT COST-** The sum of all costs resulting from applied research, engineering design, analysis, development, test, evaluation, and management development efforts related to a specific materiel system.  
 (DA PAM 11-2)  
 7 digits, 2 decimal places

**Glossary Definition...**

**EQUIPMENT Attribute**

- 21) INVESTMENT COST  
 Decimal Value  
 width=8 places=2  
 INVESTMENT COST- The sum of all costs resulting from the production and introduction of the materiel system into the Army's operational inventory.  
 (DA PAM 11-3)  
 7 digits, 2 decimal places
  
- 22) OPERATING & SUPPORT COST  
 Decimal Value  
 width=8 places=2  
 OPERATING & SUPPORT COST- The sum of all costs resulting from the operation, maintenance, and support (including personnel support) of the weapon system after it is accepted into the Army's inventory.  
 (DA PAM 11-4)  
 7 digits, 2 decimal places
  
- 23) UNIT PRICE  
 Decimal Value  
 width=8 places=2  
 UNIT PRICE- The best estimated price for one unit of equipment.  
 (DARCOM-P 750-16)  
 7 digits, 2 decimal places
  
- 24) TASK  
 Sub-Entity refers to:  
 TASK  
 (Limit of 20)  
 TASK- A listing of the tasks associated with a particular piece of equipment. A task is a unit of work activity that constitutes a logical and necessary step in the performance of a job/duty.  
 (TRADOC CIR 350-3)  
 This attribute refers to the TASK entity.
  
- 25) COST CATEGORY FIVE  
 Decimal Value  
 width=8 places=2  
 COST CATEGORY FIVE- An additional equipment cost category to be used by the individual SDI user as he so desires.  
 7 digits, 2 decimal places
  
- 26) COST CATEGORY SIX  
 Decimal Value  
 width=8 places=2  
 COST CATEGORY SIX- An additional equipment cost category to be used by the individual SDI user as he so desires.  
 7 digits, 2 decimal places
  
- 27) COST CATEGORY SEVEN  
 Decimal Value  
 width=8 places=2  
 COST CATEGORY SEVEN- An additional equipment cost category to be used by the individual SDI user as he so desires.  
 7 digits, 2 decimal places

EQUIPMENT Attribute  
-----

Glossary Definition...  
-----

- |   |   |
|---|---|
| 28) COST CATEGORY EIGHT<br>Decimal Value<br>width=8 places=2  | COST CATEGORY EIGHT-<br>An additional equipment cost category to be used by the<br>individual SDT user as he so desires.<br>7 digits, 2 decimal places  |
| 29) COST CATEGORY NINE<br>Decimal Value<br>width=8 places=2   | COST CATEGORY NINE-<br>An additional equipment cost category to be used by the<br>individual SDT user as he so desires.<br>7 digits, 2 decimal places   |
| 30) COST CATEGORY TEN<br>Decimal Value<br>width=8 places=2    | COST CATEGORY TEN-<br>An additional equipment cost category to be used by the<br>individual SDT user as he so desires.<br>7 digits, 2 decimal places    |
| 31) COST CATEGORY ELEVEN<br>Decimal Value<br>width=8 places=2 | COST CATEGORY ELEVEN-<br>An additional equipment cost category to be used by the<br>individual SDT user as he so desires.<br>7 digits, 2 decimal places |
| 32) COST CATEGORY TWELVE<br>Decimal Value<br>width=8 places=2 | COST CATEGORY TWELVE-<br>An additional equipment cost category to be used by the<br>individual SDT user as he so desires.<br>7 digits, 2 decimal places |

```

*****
Entity Name      Nbr Type      Glossary Definition...
-----

```

```

Software Requirmts 7 Sub-Entity SOFTWARE REQUIREMENTS- A listing of the functions performed by the software
associated with a particular piece of equipment.
*****

```

```

Software Requirmts Attribute      Glossary Definition...
-----

```

- 1) SOFTWARE REQUIRMENTS TITLE  
Character String  
20 Characters
- SOFTWARE REQUIRMENTS TITLE- Description of the functions performed by the  
software associated with a particular type of  
equipment.  
20 characters



```

*****
Entity Name      Mbr Type      Glossary Definition...
-----
Information Input  9 Sub-Entity  INFORMATION INPUT-  A description of the information elements which the
                    hardware/software configuration must have to perform its
                    function.
*****

```

Information Input Attribute -----  
 Glossary Definition... -----

1) INFORMATION INPUT TITLE  
 Character String  
 25 Characters

2) EQUIPMENT SOURCE NUMBER  
 Character String  
 10 Characters

EQUIPMENT SOURCE NUMBER- The number of the equipment producing the  
 information input.  
 10 characters

\*\*\*\*\*

Entity Name            Mbr Type            Glossary Definition...

Information Output    10 Sub-Entity    INFORMATION OUTPUT- A description of the information produced by a specific equipment hardware/software configuration.

\*\*\*\*\*

Information Output Attribute            Glossary Definition...

1) INFORMATION OUTPUT TITLE            INFORMATION OUTPUT TITLE- Name of the Information Output.  
Character String                            25 characters

2) EQUIPMENT SOURCE NUMBER            EQUIPMENT SOURCE NUMBER- The number of the equipment which receives the information output.  
Character String                            10 Characters

\*\*\*\*\*

Entity Name Mbr Type Glossary Definition...

TASK 11 Regular TASK- A unit of work activity that constitutes a logical and necessary step in the performance of a job/duty. In describing a task statement/description it should be detailed enough to provide minimal step-by-step directions and guidance that an individual in training could follow to complete the task successfully. (TRADOC CIR 350-3)

TASK Attribute Glossary Definition...

1) TITLE Task name including action verb and object.

Character String 39 Characters

2) TASK NUMBERS Sub-Entity refers to: Task Numbers (Single Sub-entity) TASK NUMBERS- This attribute is a sub-entity containing the following task numbers: Enlisted Task Number Officer Task Number Enlisted Replacement Task Number Officer Task Replacement Number Addition Task Number

3) TYPE Type of task TYPE- Type of task Select from List number 10

4) STATUS Task status STATUS- Task status Select from List number 11

5) WORK AREA A description of the generic work area in which task will be performed. 6 characters WORK AREA- A description of the generic work area in which task will be performed. 6 characters Character String 20 Characters

TASK Attribute

Glossary Definition...

6) TASK AREA  
Character String  
20 Characters

TASK AREA- A lower level description of the work area in which a task will be performed.  
5 characters

7) AMOUNT OF SUPERVISION  
Select from List  
number 22

AMOUNT OF SUPERVISION- Amount of supervision

8) NUMBER PERFORMING  
Integer Value  
from 0 to 10000

NUMBER PERFORMING- Number of individuals performing the task.

9) FREQ/DURATION MEAS.  
Sub-Entity refers to:  
Freq/Duration Meas.  
(Single Sub-entity)

FREQUENCY AND DURATION MEASURES- This attribute is a sub-entity containing measures of frequency and duration. There may be only one such entity per task.

10) TRAIN. ASSIGNMENTS  
Sub-Entity refers to:  
Training Assignment  
(Single Sub-entity)

TRAINING ASSIGNMENTS- This attribute is a sub-entity containing:  
Initial Training Assignment Type  
Qualifying Training Assignment Type  
Additional Assignment Type

11) PRECEDING TASKS  
Sub-Entity refers to:  
TASK  
(Limit of 4)

PRECEDING TASKS- A list of the tasks which must be performed before the designated task for successful system performance.  
This attribute is another task entity. There may be as many as 4 preceding tasks.

12) SUCCEEDING TASKS  
Sub-Entity refers to:  
TASK  
(Limit of 4)

SUCCEEDING TASKS- A list of the tasks which follow the designated task during successful system performance.  
This attribute is another task entity. There may be as many as 4 preceding tasks.

13) TASK ELEMENT  
Sub-Entity refers to:  
Task Element  
(No Limit)

TASK ELEMENT- A description of the specific elements associated with the task.  
This attribute is a sub-entity. There may be any number of Task Elements associated with a task.

**Blossary Definition...**

**TASK Attribute**

- 14) **TASK CONDITION**  
Sub-Entity refers to:  
Task Condition  
(No Limit)  
**TASK CONDITION-** A description of the conditions under which the task must be performed.  
This attribute is a sub-entity. There may be any number of Task Conditions associated with a task.
- 15) **TASK STANDARD**  
Sub-Entity refers to:  
Task Standard  
(No Limit)  
**TASK STANDARD-** A description of the task standards.  
This attribute is a sub-entity. There may be 3 Task Standards associated with a task.
- 16) **INITIATING CUES**  
Sub-Entity refers to:  
Initiating Cue  
(No Limit)  
**INITIATING CUES-** A description of the initiating cues associated with a task.  
This attribute is a sub-entity. There may be 3 Initiating Cues associated with a task.
- 17) **TERMINATING CUES**  
Sub-Entity refers to:  
Terminating Cue  
(No Limit)  
**TERMINATING CUES-** A description of terminating cues associated with a task.  
This attribute is a sub-entity. There may be 3 Terminating Cues associated with a task.
- 18) **TOOLS/TEST EQUIPMENT**  
Sub-Entity refers to:  
Tools & Test Equip.  
(No Limit)  
**TOOLS/TEST EQUIPMENT-** A description of the tools and test equipment which must be available to adequately perform a task.  
This attribute is a sub-entity. There may be 4 Tools/ Test Equipments associated with each task.
- 19) **FAILURE MODES**  
Sub-Entity refers to:  
Failure Mode  
(No Limit)  
**FAILURE MODES-** A description of the equipment failure modes which initiate task performance (for maintenance tasks only).  
This attribute is a sub-entity. There may be 3 Failure Modes associated with a task.
- 20) **SKILLS AND KNOWLEDGES**  
Sub-Entity refers to:  
Skills & Knowledges  
(No Limit)  
**SKILLS AND KNOWLEDGES-** A list of the skills and knowledges associated with the task.  
This attribute is a sub-entity. There may be 9 Skills and Knowledges associated with a task.
- 21) **LEARNING OBJECTIVES**  
Sub-Entity refers to:  
Learning Objective  
(No Limit)  
**LEARNING OBJECTIVES-** A list of the learning objectives associated with the task.  
This attribute is a sub-entity. There may be 6 Learning Objectives associated with a task.

Glossary Definition...

TASK Attribute

- 22) PERFORMANCE MEASURES- A list of the performance measures associated with the task.  
 Sub-Entity refers to: Performance Measure (No Limit)  
 This attribute is a sub-entity. There may be 3 Performance Measures associated with a task.
- 23) STIMULI- Method of Stimuli Presentation.  
 Sub-Entity refers to: Stimuli (No Limit)  
 This attribute is a sub-entity. There is no limit to the number of stimuli associated with a task.
- 24) RESPONSES- Response mode of implementation.  
 Sub-Entity refers to: Responses (No Limit)  
 This attribute is a sub-entity. There is no limit to the number of responses associated with a task.
- 25) FEEDBACKS- Medium of feedback presentation.  
 Sub-Entity refers to: Feedbacks (No Limit)  
 This attribute is a sub-entity. There is no limit to the number of feedbacks associated with a task.
- 26) TRAIN. EMPHASIS SCALES- A Single sub-entity containing:  
 Sub-Entity refers to: Training Emphasis (Single Sub-entity)  
 Percent Performing  
 Consequences of Inadequate Performance  
 Delay Tolerance  
 Learning Difficulty  
 Probability of Deficient Performance  
 Time from Entry to Performance
- 27) METHOD VARIABLES- This attribute is a sub-entity containing:  
 Sub-Entity refers to: Method Variables (Single Sub-entity)  
 Task Role  
 Activity Performed in Role  
 Stability of Activity  
 Physical Context  
 Psychological Impact
- 28) TASK CHARACTERISTIC ONE- An additional task characteristic to be used by the individual SDT user as he so desires.  
 Character String  
 5 Characters
- TASK CHARACTERISTIC ONE- An additional task characteristic to be used by the individual SDT user as he so desires.  
 5 characters

TASK Attribute

Glossary Definition...

- |   |  |
|---|--|
| 29) TASK CHARACTERISTIC TWO<br>Character String<br>5 Characters   | TASK CHARACTERISTIC TWO--<br>An additional task characteristic to be used by the individual SDT user as he so desires.<br>5 characters   |
| 30) TASK CHARACTERISTIC THREE<br>Character String<br>5 Characters | TASK CHARACTERISTIC THREE--<br>An additional task characteristic to be used by the individual SDT user as he so desires.<br>5 characters |
| 31) TASK CHARACTERISTIC FOUR<br>Character String<br>5 Characters  | TASK CHARACTERISTIC FOUR--<br>An additional task characteristic to be used by the individual SDT user as he so desires.<br>5 characters  |
| 32) TASK CHARACTERISTIC FIVE<br>Character String<br>5 Characters  | TASK CHARACTERISTIC FIVE--<br>An additional task characteristic to be used by the individual SDT user as he so desires.<br>5 characters  |
| 33) TASK CHARACTERISTIC SIX<br>Character String<br>5 Characters   | TASK CHARACTERISTIC SIX--<br>An additional task characteristic to be used by the individual SDT user as he so desires.<br>5 characters   |
| 34) TASK CHARACTERISTIC SEVEN<br>Character String<br>5 Characters | TASK CHARACTERISTIC SEVEN--<br>An additional task characteristic to be used by the individual SDT user as he so desires.<br>5 characters |
| 35) TASK CHARACTERISTIC EIGHT<br>Character String<br>5 Characters | TASK CHARACTERISTIC EIGHT--<br>An additional task characteristic to be used by the individual SDT user as he so desires.<br>5 characters |
| 36) TASK CHARACTERISTIC NINE<br>Character String<br>5 Characters  | TASK CHARACTERISTIC NINE--<br>An additional task characteristic to be used by the individual SDT user as he so desires.<br>5 characters  |

TASK Attribute  
-----

Glossary Definition...  
-----

37) TASK CHARACTERISTIC TEN  
Character String  
5 Characters

TASK CHARACTERISTIC TEN-  
An additional task characteristic to be used by the  
individual SDT user as he so desires.  
5 characters

38) TASK CHARACTERISTIC ELEVEN  
Character String  
5 Characters

TASK CHARACTERISTIC ELEVEN-  
An additional task characteristic to be used by the  
individual SDT user as he so desires.  
5 characters

39) TASK CHARACTERISTIC TWELVE  
Character String  
5 Characters

TASK CHARACTERISTIC TWELVE-  
An additional task characteristic to be used by the  
individual SDT user as he so desires.  
5 characters



Task Numbers Attribute

Glossary Definition...

5) ADDITIONAL TASK NUMBER  
Character String  
10 Characters

ADDITIONAL TASK NUMBER-

An additional field to allow the individual SDI user  
to use his/her unique task identification code.  
10 characters

\*\*\*\*\*  
 Entity Name      Mbr Type      Glossary Definition...  
 -----  
 Freq/Duration Meas.    13 Single-Sub    Frequency and Duration Measures.  
 \*\*\*\*\*

Freq/Duration Meas. Attribute      Glossary Definition...  
 -----

- 1) FREQUENCY  
    Decimal Value  
    width=10 places=3  
    FREQUENCY- A numeric value describing the frequency with which the task is performed.  
               9 digits, 3 decimal places
  
- 2) FREQ MEASUREMENT BASE  
    Character String  
    10 Characters  
    FREQUENCY MEASUREMENT BASE- The specific unit of measurement (for example, hours, weeks) used in describing the task frequency.  
                                   10 characters
  
- 3) DURATION (MANHOURS)  
    Decimal Value  
    width=8 places=2  
    DURATION (MANHOURS)- An estimate of the total number of manhours it will take to perform the task.  
                           7 digits, 2 decimal places
  
- 4) ELAPSED TIME ESTIMATED  
    Decimal Value  
    width=8 places=2  
    ELAPSED TIME ESTIMATED- Estimate of how long it will take to perform a task, in manhours.  
                           7 digits, 2 decimal places
  
- 5) ELAPSED TIME PREDICTED  
    Decimal Value  
    width=8 places=2  
    ELAPSED TIME PREDICTED- Prediction of how long it will take to perform the task, in hours.  
                           7 digits, 2 decimal places
  
- 6) ELAPSED TIME MEASURED  
    Decimal Value  
    width=8 places=2  
    ELAPSED TIME MEASURED- A measurement of the time it took to perform a task.  
                           7 digits, 2 decimal places

Freq/Duration Meas. Attribute

- 7) ELAPSED MEASUREMENT BASE  
Character String  
10 Characters

Glossary Definition...

- ELAPSED MEASUREMENT BASE-

Metric upon which elapsed time measurements are made.  
7 digits, 2 decimal places

```

*****
Entity Name      Nbr Type      Glossary Definition...
-----
Training Assignment 14 Single-Sub Initial, Qualifying, and Additional Assignment types.
*****

```

```

Training Assignment Attribute      Glossary Definition...
-----

```

```

1) INITIAL TRAIN.ASSIGN.TYPE
   Select from List
   number 12

```

```

INITIAL TRAINING ASSIGNMENT TYPE

```

```

2) QUALIF. TRAIN.ASSIGN.TYPE
   Select from List
   number 12

```

```

QUALIFYING TRAINING ASSIGNMENT TYPE

```

```

3) ADDITIONAL ASSIGNMENT TYP
   Select from List
   number 12

```

```

ADDITIONAL ASSIGNMENT TYPE

```

```

*****
Entity Name      Nbr Type      Glossary Definition...
-----
Task Element    15 Sub-Entity  TASK ELEMENT- The smallest unit of behavior that has practical meaning to
                    instructional analysts/designers. Elements are in turn
                    composed of steps which are basic notions, movements, mental
                    processes.
*****

```

```

Task Element Attribute -----
Glossary Definition...
-----

```

```

1) ELEMENT TITLE
   Character String
   79 Characters

ELEMENT TITLE- The title of the task element.
79 characters.

```

```

*****
Entity Name      Nbr Type      Glossary Definition...
-----
Task Condition  16 Sub-Entity  TASK CONDITION- The factors which describe the necessary equipment and
                    physical setting under which the soldier is required to
                    accomplish the specified task on the job. Conditions
                    describe the important aspects of the performance environment.
                    (TRADOC CIR 350-3)
*****

```

```

Task Condition Attribute      Glossary Definition...
-----

```

- 1) CONDITION TITLE  
Character String  
30 Characters
- CONDITION TITLE- The title of the task condition.

```

*****
Entity Name      Mbr Type      Glossary Definition...
-----
Task Standard   17 Sub-Entity  TASK STANDARD-  An observable measure which specifies how well, completely,
or accurately a process must be performed or product produced.
The standard reflects the task requirements on the job.
(Adapted from TRADOC CIR 350-3)
*****

```

```

Task Standard Attribute  Glossary Definition...
-----

```

- 1) TASK STANDARD MEASURE  
Character String  
30 Characters
- 2) AMOUNT / VALUE  
Character String  
10 Characters
- AMOUNT / VALUE- The quantitative value which must be achieved on the task  
standard Measure.  
10 characters.
- TASK STANDARD MEASURE- A description of the variable on which the task  
standard will be measured.  
10 characters.

```

*****
Entity Name      Mbr Type      Glossary Definition...
-----
Initiating Cue   18 Sub-Entity  INITIATING CUES- A word or other signal that initiates behavior; a prompt.
*****

```

```

Initiating Cue Attribute -----
Glossary Definition... -----

```

```

1) INITIATING CUE TITLE      Name assigned to initiating cue.
   Character String          30 characters.
   30 Characters

```

```

2) RELATED EQUIPMENT NUMBER  Number of the equipment from which the initiating
   Character String          cue is derived.
   10 Characters             10 characters.

```

```

*****
Entity Name      Mbr Type      Glossary Definition...
-----
Terminating Cue  19 Sub-Entity  TERMINATING CUES- A word or other signal that terminates behavior.
*****

```

```

Terminating Cue Attribute  Glossary Definition...
-----

```

```

1) TERMINATING CUE TITLE
   Character String
   30 Characters

   TERMINATING CUE TITLE- Title of the terminating cue.
   30 characters.

```

```

2) RELATED EQUIPMENT NUMBER
   Character String
   10 Characters

   RELATED EQUIPMENT NUMBER- Number of the equipment which initiates the
   terminating cue.
   10 characters.

```



```

*****
Entity Name      Mbr Type      Failure Mode      21 Sub-Entity  FAILURE MODES-  A description of the equipment failure modes which initiate
-----
Glossary Definition...
task performance (for maintenance tasks only).
*****

```

```

Failure Mode Attribute -----
Glossary Definition...
-----

```

- 1) FAILURE MODE  
Character String  
39 Characters
- 2) PER CENT OF FAILURES  
Integer Value  
from 0 to 100

```

PER CENT OF FAILURES- Per cent of system failures attributable to the
failure mode.

```

\*\*\*\*\*

Entity Name Mbr Type Glossary Definition...

Skills & Knowledges 22 Sub-Entity SKILLS AND KNOWLEDGES- Skill: The ability to use one's knowledge effectively and readily in execution or performance. Knowledge: The minimum information about conditions desired goals or end results, and means and methods for reaching goals needed by the worker to insure success in performing a task.

Skills & Knowledges Attribute Glossary Definition...

1) TITLE Character String 39 Characters TITLE- Title of the skill or knowledge. 30 characters.

2) TYPE Select from List number 49 TYPE- Entry level Skill/Knowledge -or- Skill/Knowledge trained in system.

3) CATEGORY Character String 6 Characters CATEGORY- A description of the category into which the skill or knowledge falls. 6 characters.

4) CHARACTERISTIC ONE Character String 5 Characters CHARACTERISTIC ONE- A characteristic for describing skills and knowledge to be used by the individual SDT user as he so desires. 5 characters.

5) CHARACTERISTIC TWO Character String 5 Characters CHARACTERISTIC TWO- A characteristic for describing skills and knowledge to be used by the individual SDT user as he so desires. 5 characters.

```

*****
Entity Name      Mbr Type      Glossary Definition...
-----

```

```

Learning Objective 23 Sub-Entity  LEARNING OBJECTIVES-  A subunit of terminal learning objective consisting of a
precise description of what is to be learned in terms of
the expected student performance under specified conditions
to accepted standards.
*****

```

```

Learning Objective Attribute      Glossary Definition...
-----

```

```

1) LEARNING OBJECTIVE
   Character String
   39 Characters

```

```

2) CHARACTERISTIC 1-
   Character String
   5 Characters

```

CHARACTERISTIC 1- Characteristic to be used to describe the learning objectives. These characteristics are to be used by the individual SDT user as he so desires. 5 characters.

```

3) CHARACTERISTIC 2-
   Character String
   5 Characters

```

CHARACTERISTIC 2- Characteristic to be used to describe the learning objectives. These characteristics are to be used by the individual SDT user as he so desires. 5 characters.

```

4) CHARACTERISTIC 3-
   Character String
   5 Characters

```

CHARACTERISTIC 3- Characteristic to be used to describe the learning objectives. These characteristics are to be used by the individual SDT user as he so desires. 5 characters.

```

5) CHARACTERISTIC 4-
   Character String
   5 Characters

```

CHARACTERISTIC 4- Characteristic to be used to describe the learning objectives. These characteristics are to be used by the individual SDT user as he so desires. 5 characters.

Skills & Knowledges Attribute

6) CHARACTERISTIC THREE  
Character String  
5 Characters

7) CHARACTERISTIC FOUR  
Character String  
5 Characters

8) CHARACTERISTIC FIVE  
Character String  
5 Characters

9) CHARACTERISTIC SIX  
Character String  
5 Characters

Glossary Definition...

CHARACTERISTIC THREE- A characteristic for describing skills and knowledge to be used by the individual SDT user as he so desires.  
5 characters.

CHARACTERISTIC FOUR- A characteristic for describing skills and knowledge to be used by the individual SDT user as he so desires.  
5 characters.

CHARACTERISTIC FIVE- A characteristic for describing skills and knowledge to be used by the individual SDT user as he so desires.  
5 characters.

CHARACTERISTIC SIX- A characteristic for describing skills and knowledge to be used by the individual SDT user as he so desires.  
5 characters.

```

*****
Entity Name      Mbr Type      Glossary Definition...
-----
Performance Measure 24 Sub-Entity PERFORMANCE MEASURES- The absolute standard by which a job performance is
judged. A performance measure is the inventory of job
tasks with each performed objective.
(TRADOC PAN 350-30)
*****

```

```

-----
Performance Measure Attribute      Glossary Definition...
-----

```

```

1) PERFORMANCE MEASURE
   Character String
   39 Characters

PERFORMANCE MEASURE- A description of the specific variable which will be
used to measure task performance.
39 characters.

```

```

2) AMOUNT/VALUE
   Decimal Value
   width=10 places=2

AMOUNT/VALUE- The quantitative value which must be achieved on the task
measure.
9 digits, 2 decimal places.

```



Stimuli Attribute

Glossary Definition...

7) AUDIO SOURCES  
Select from List  
number 34

AUDIO SOURCES - Type of Audio Source.

8) AUDIO STIMULI INTENSITY  
Select from List  
number 35

AUDIO STIMULI INTENSITY - Weak or Strong.

9) STIMULI PRESENTATION  
Select from List  
number 36

STIMULI PRESENTATION - Static / Dynamic ordered / Dynamic random.

10) STIMULI PRESENTN. RATE  
Select from List  
number 37

STIMULI PRESENTATION RATE - Slow or Fast.

11) NUMBER OF CHANNELS  
Select from List  
number 38

NUMBER OF CHANNELS OR SOURCES - Number of sources, channels, or instruments through which stimuli are presented to the trainee.

12) STIMULI DISTRIBUTION  
Select from List  
number 50

STIMULI DISTRIBUTION - Individual or group.

\*\*\*\*\*

Entity Name                      Nbr Type                      Glossary Definition...

Responses                      26 Sub-Entity                      Responses to Stimuli.

Responses Attribute                      Glossary Definition...

1) RESPONSE MODE                      Mode of Implementation.

Select from List  
number 39

2) INTENSITY OF RESPONSE                      Weak or Strong

Select from List  
number 40

3) RESPONSE IMPLEMENTATION                      Static / Dynamic-ordered / Dynamic-random

Select from List  
number 41

4) REQUIRED RESPONSE RATE                      Slow rate or Fast rate

Select from List  
number 42

5) # RESPONSE CHANNELS                      Limited or unlimited number of sources, channels,

Select from List                      or instruments through which responses are Made  
number 43                      by the trainee.

6) RESPONSE DISTRIBUTION                      from one individual trainee or from

Select from List                      a group of trainees.  
number 44





-----  
Training Emphasis Attribute

-----  
Glossary Definition...

6) PROB. DEFIC. PERFORMANCE  
Integer Value  
from 1 to 7

PROBABILITY OF DEFICIENT PERFORMANCE-- 1-Low 4-Medium 7-High

7) TIME FROM ENTRY TO PRFRM.  
Integer Value  
from 1 to 7

TIME FROM ENTRY TO PERFORMANCE-- Amount of time between job entry and  
task performance.  
1-Low 4-Medium 7-High



\*\*\*\*\*  
Entity Name            Mbr Type            Glossary Definition...  
-----

COURSE            30 Regular            COURSE- A program of instruction covering a specific set of learning objectives.  
\*\*\*\*\*

COURSE Attribute            Glossary Definition...  
-----

1) TITLE  
Character String            39 characters

2) COURSE NUMBER  
Character String            20 Characters

3) COURSE LENGTH  
  Decimal Value            width=8 places=2  
  COURSE LENGTH-            The length of the course, in weeks. For a proposed course, it may be computed as the sum, over all methods of instruction, of the duration of each method. If this data is not available, an estimate may be supplied. The units for class length are weeks. 7 digits, 2 decimal places.

4) TYPE  
  Select from List            number 50  
  COURSE TYPE-            Type of training course.

5) ALTERNATIVE  
  Character String            10 Characters  
  ALTERNATIVE-            A code used to describe the training alternative (if any) with which the course is associated. 10 characters

6) STATUS  
  Select from List            number 51  
  STATUS-            Course status: proposed, modified/existing, or existing.

COURSE Attribute  
-----

Glossary Definition...  
-----

- 7) **COMPARABLE COURSE**  
Character String  
39 Characters
- COMPARABLE COURSE-** Comparable Existing Course Title: Title of an existing course which can be used in comparability analysis to determine resource and cost requirements for the projected course.  
39 characters
- 8) **COMPARABLE NUMBER**  
Character String  
20 Characters
- COMPARABLE NUMBER-** Comparable Existing Course Number: Number of the comparable existing course.  
20 characters
- 9) **PREREQUISITE COURSES**  
Sub-Entity refers to:  
COURSE  
(Limit of 5)
- PREREQUISITE COURSES-** A list of COURSES which must be successfully completed prior to a student's entry to the designated course.  
This attribute is a list of COURSE entities.
- 10) **FOLLOW-ON COURSES**  
Sub-Entity refers to:  
COURSE  
(Limit of 6)
- FOLLOW-ON COURSES-** COURSES which are likely to be taken after the designated course (based upon the career path structure for the MOS).  
This attribute is a list of COURSE entities.
- 11) **ATTRITION RATE**  
Decimal Value  
width=5 places=3
- ATTRITION RATE-** For a proposed course, the attrition rate is he expected rate of attrition as a percentage of the students entering the course. (This is a number between 0 and 1) For an existing course, the attrition rate can be calculated as follows:  
(#students who start - #students who finish)/#students who start  
4 digits, 3 decimal places.
- 12) **MAXIMUM CLASS SIZE**  
Integer Value  
from 0 to 30000
- MAXIMUM CLASS SIZE-** largest number of students allowed into a class due to space or instructional constraints.
- 13) **CLASS FREQUENCY**  
Decimal Value  
width=8 places=2
- CLASS FREQUENCY-** Existing: The average number of times the class is taught each year (averaging across locations)  
Proposed: Calculated as the average number of graduates required each year divided by the maximum class size. This number is the number of times the class is taught each year.  
7 digits, 2 decimal places

COURSE Attribute  
-----

Glossary Definition...  
-----

14) RESOURCE REQUIREMENTS

Sub-Entity refers to:  
Course Resource Req  
(Single Sub-entity)

COURSE RESOURCE REQUIREMENTS- This attribute is a sub-entity containing the following attributes: # Norm Graduates Quarters/Mess Available  
Per Cent Officer Graduates Per Cent IDY-status Grads  
ICH per Class Number of Instructors  
Man-days P8 Troop Support Man-days P2/3 Support

15) COURSE COSTS

Sub-Entity refers to:  
Course Costs  
(Single Sub-entity)

COURSE COSTS- This attribute is a sub-entity containing course costs.

16) STUDENT INPUT REQTS.

Sub-Entity refers to:  
Student Input Reqts  
(Single Sub-entity)

STUDENT INPUT REQUIREMENTS- This attribute is a sub-entity containing student input requirements.

17) MODULE

Sub-Entity refers to:  
Course Module  
(No Limit)

COURSE MODULE- This attribute is a chain of sub-entities describing the modules associated with a course.

\*\*\*\*\*

Entity Name                      Nbr Type                      Glossary Definition...

-----

Course Resource Req 31 Single-Sub      COURSE RESOURCE REQUIREMENTS- Resources required by the Course.

\*\*\*\*\*

Course Resource Req Attribute                      Glossary Definition...

-----

1) # NORM GRADUATES                      # NORM GRADUATES- Normalized graduates for an existing course are the number of students who satisfactorily completed the course (graduate) adjusted for carryovers, i.e., actual grads minus one-half of the students in training in the beginning of the most recent fiscal year plus one half of the students in training at the end of that fiscal year. 8 digits, 2 decimal places

Decimal Value  
width=8 places=2

2) QUARTERS/MESS AVAILABLE                      QUARTERS/MESS AVAILABLE- Indicates whether quarters and mess are available at the place of instruction.

Select from List  
number 52

3) PERCENT OFFICER GRADUATES                      PERCENT OFFICER GRADUATES- The percent of the total number of graduates of the course who are officers (A number between 0.0 and 100.00)

Decimal Value  
width=6 places=2

4) PERCENT TDY-STATUS GRADS                      PERCENT TDY-STATUS GRADS- The percent of the total number of graduates with temporary duty (TDY) status. (A number between 0.0 and 100.0)

Decimal Value  
width=6 places=2

5) ICH PER CLASS                      ICH PER CLASS- The number of instructor contact hours per class. Computed as the sum, over all methods of instruction, of the hours of that method times the maximum class size divided by the student/instructor ratio for that method. 7 digits, 2 decimal places

Decimal Value  
width=8 places=2

6) NUMBER OF INSTRUCTORS                      NUMBER OF INSTRUCTORS- The number of instructors needed to teach the course, computed as the number of instructor contact hours per class times the class frequency divided by 1250 (the number of hours each instructor is available for class each year). (reference DA PAM 570-558) 7 digits, 2 decimal places

Decimal Value  
width=8 places=2

Course Resource Req Attribute -----

Glossary Definition... -----

7) MAN-DAYS P8 TROOP SUPPORT  
Decimal Value  
width=8 places=2

MAN-DAYS P8 TROOP SUPPORT- The number of man-days of P8 troop support to  
the course per class.  
7 digits, 2 decimal places

8) MAN-DAYS P2/3 SUPPORT  
Decimal Value  
width=8 places=2

MAN-DAYS P2/3 SUPPORT- The number of man-days of P2/3 troop support to the  
course per class.  
7 digits, 2 decimal places

\*\*\*\*\*

Entity Name Mbr Type Glossary Definition...

Course Costs 32 Single-Sub COURSE COSTS- Costs associated with the Course.

Course Costs Attribute Glossary Definition...

- 1) INSTRUCTIONAL DEPT (OMA)  
 Decimal Value  
 width=8 places=2  
 INSTRUCTIONAL DEPT (OMA) COST-  
 Operation and Maintenance, Army (OMA) cost of the academic departments; this includes pay and allowances of instructors and academic department staff, consumable supplies and equipment, and contractual services.  
 7 digits, 2 decimal places
- 2) INSTRUCTIONAL DEPT (MPA)  
 Decimal Value  
 width=8 places=2  
 INSTRUCTIONAL DEPT (MPA) COST-  
 Military personnel, Army (MPA) cost of the academic departments; this includes pay and allowances of instructors and academic department staff, consumable supplies and equipment, and contractual services.  
 7 digits, 2 decimal places
- 3) FLYING HOUR COST/STUDENT  
 Decimal Value  
 width=8 places=2  
 FLYING HOUR COST PER STUDENT-  
 Operation and Maintenance, Army (OMA) and Military Personnel, Army (MPA) costs of flying hour instruction.  
 7 digits, 2 decimal places
- 4) DIRECT MISSION OTHER(OMA)  
 Decimal Value  
 width=8 places=2  
 DIRECT MISSION OTHER (OMA) COST-  
 Operation and Maintenance, Army (OMA) school overhead costs such as commandant, office of the secretary, director of logistics, director of support, director of evaluation, school brigade, etc.  
 7 digits, 2 decimal places
- 5) DIRECT MISSION OTHER(MPA)  
 Decimal Value  
 width=8 places=2  
 DIRECT MISSION OTHER (MPA) COST-  
 Military Personnel, Army (MPA) school overhead costs such as commandant, office of the secretary, director of logistics, director of support, director of evaluation, school brigade, etc.  
 7 digits, 2 decimal places

\*\*\*\*\*

Course Costs Attribute  
-----

Blossary Definition...  
-----

- 6) P8 TROOP SUPPORT (OMA)  
Decimal Value  
width=8 places=2
- P8 TROOP SUPPORT (OMA) COST- Operation and Maintenance, Army (OMA) cost of P8 troop support to the course.  
7 digits, 2 decimal places
- 7) P8 TROOP SUPPORT (MPA)  
Decimal Value  
width=8 places=2
- P8 TROOP SUPPORT (MPA) COST- Military Personnel, Army (MPA) cost of P8 troop support to the course.  
7 digits, 2 decimal places
- 8) P8 TROOP SUPPORT (PA)  
Decimal Value  
width=8 places=2
- P8 TROOP SUPPORT (PA) COST- Procurement, Army (PA) cost of P8 troop support to the course.  
7 digits, 2 decimal places
- 9) P2/3 TROOP SUPPORT (OMA)  
Decimal Value  
width=8 places=2
- P2/3 TROOP SUPPORT (OMA) COST- Operation and Maintenance, Army (OMA) cost of P2/3 troop support to the course.  
7 digits, 2 decimal places
- 10) P2/3 TROOP SUPPORT (MPA)  
Decimal Value  
width=8 places=2
- P2/3 TROOP SUPPORT (MPA) COST- Military Personnel, Army (MPA) cost of P2/3 troop support to the course.  
7 digits, 2 decimal places
- 11) P2/3 TROOP SUPPORT (FHMA)  
Decimal Value  
width=8 places=2
- P2/3 TROOP SUPPORT (FHMA) COST- Procurement, Army (PA) cost of P2/3 troop support to the course.  
7 digits, 2 decimal places
- 12) AMMUNITION COST/STUDENT  
Decimal Value  
width=8 places=2
- AMMUNITION COST PER STUDENT- The cost per student of ammunition used in the course.  
7 digits, 2 decimal places
- 13) EQUIP DEPREC. PER GRAD  
Decimal Value  
width=8 places=2
- EQUIPMENT DEPRECIATION PER GRADUATE- Costs of equipment dedicated to the course, non-dedicated departmental equipment (adjusted by the number of instructor contact hours per year) and school overhead equipment (adjusted by the number of training man-weeks per year); these costs are amortized over a 10-year period. (worksheets provided)  
7 digits, 2 decimal places

Course Costs Attribute	Glossary Definition...
14) TRAVEL PAY TO COURSE (OMA) Decimal Value width=8 places=2	TRAVEL PAY TO COURSE (OMA)- Operation and Maintenance, Army (OMA) cost of travel pay to students with temporary-duty status (TDY). 7 digits, 2 decimal places
15) TRAVEL PAY TO COURSE (MPA) Decimal Value width=8 places=2	TRAVEL PAY TO COURSE (MPA)- Military Personnel, Army (MPA) cost of travel pay to students with temporary-duty status (TDY) in conjunction with permanent change of status (PCS) status. 7 digits, 2 decimal places
16) BASE OPERATIONS (OMA) Decimal Value width=8 places=2	BASE OPERATIONS (OMA)- Operation and Maintenance, Army (OMA) cost to the base operations functional account; adjusted by the number of training man-weeks per year. 7 digits, 2 decimal places
17) BASE OPERATIONS (MPA) Decimal Value width=8 places=2	BASE OPERATIONS (MPA)- Military Personnel, Army (OMA) cost to the base operations functional account; adjusted by the number of training man-weeks per year. 7 digits, 2 decimal places
18) TRAINING AIDS (OMA) Decimal Value width=8 places=2	TRAINING AIDS (OMA)- Operation and Maintenance, Army (OMA) cost of installation-supported training aids, adjusted by the total number of training man-weeks. 7 digits, 2 decimal places
19) TRAINING AIDS (MPA) Decimal Value width=8 places=2	TRAINING AIDS (MPA)- Military Personnel, Army (OMA) cost of installation-supported training aids, adjusted by the total number of training man-weeks. 7 digits, 2 decimal places
20) OTHER SUPPORT COSTS (OMA) Decimal Value width=8 places=2	OTHER SUPPORT COSTS (OMA)- Operation and Maintenance, Army (OMA) cost of installation non-base operations other than training aids, adjusted by the total number of training man-weeks. 7 digits, 2 decimal places

Course Costs Attribute -----  
Glossary Definition....

- 21) OTHER SUPPORT COSTS (MPA)  
    Decimal Value  
    width=8 places=2  
    OTHER SUPPORT COSTS (MPA)- Military Personnel, Army (OMA) cost of  
    installation non-base operations other than training  
    aids, adjusted by the total number of training  
    man-weeks.  
    7 digits, 2 decimal places
- 22) AVERAGE COST PER GRADUATE  
    Decimal Value  
    width=8 places=2  
    AVERAGE COST PER GRADUATE- The average cost of the course per graduate.  
    7 digits, 2 decimal places

```

*****
Entity Name      Mbr Type      Glossary Definition...
-----

```

```

Student Input Reqs 33 Single-Sub STUDENT INPUT REQUIREMENTS
*****

```

```

Student Input Reqs Attribute      Glossary Definition...
-----

```

```

1) START YEAR      Integer Value      The year in which the course must first be ready to accept
   from 0 to 2050  students to assure the availabilily of trained personnel at
                   system IOC.

```

```

2) LOCATION ONE   Character String   Primary location of course (location where most of the training
   15 Characters   occurs).
                   15 characters

```

```

3) #STUDENTS YEAR ONE   Integer Value     The number of students to be trained at loaction
   from 0 to 30000      #1 during the first year of training.

```

```

4) #STUDENTS YEAR TWO   Integer Value     The number of students to be trained at loaction
   from 0 to 30000      #1 during the first year of training.

```

```

5) #STUDENTS YEAR THREE   Integer Value     The number of students to be trained at loaction
   from 0 to 30000      #1 during the first year of training.

```

```

6) #STUDENTS YEAR FOUR   Integer Value     The number of students to be trained at loaction
   from 0 to 30000      #1 during the first year of training.

```

Student Input Reqs Attribute

Glossary Definition...

- 7) #STUDENTS YEAR FIVE  
Integer Value  
from 0 to 30000  
  
NUMBER OF STUDENTS YEAR FIVE- The number of students to be trained at loaction #1 during the first year of training.
- 8) #STUDENTS STEADY STATE  
Integer Value  
from 0 to 30000  
  
NUMBER OF STUDENTS STEADY STATE- The number of students to be trained at location #1 in a "steady state" year. In a "teady state" year, all of the systems have been fielded and training is strictly concerned with replacing personnel lost from the system via attrition, promotion, and other related factors. (see the procedures guide for more detailed description)
- 9) LOCATION TWO  
Character String  
15 Characters  
  
LOCATION TWO- Secondary course location.  
15 characters
- 10) #STUDENTS YEAR ONE  
Integer Value  
from 0 to 30000  
  
NUMBER OF STUDENTS YEAR ONE- The number of students to be trained at loaction #2 during the first year of training.
- 11) #STUDENTS YEAR TWO  
Integer Value  
from 0 to 30000  
  
NUMBER OF STUDENTS YEAR TWO- The number of students to be trained at loaction #2 during the first year of training.
- 12) #STUDENTS YEAR THREE  
Integer Value  
from 0 to 30000  
  
NUMBER OF STUDENTS YEAR THREE- The number of students to be trained at loaction #2 during the first year of training.
- 13) #STUDENTS YEAR FOUR  
Integer Value  
from 0 to 30000  
  
NUMBER OF STUDENTS YEAR FOUR- The number of students to be trained at loaction #2 during the first year of training.

## Student Input Reqts Attribute

## Glossary Definition...

- 14) #STUDENTS YEAR FIVE  
Integer Value  
from 0 to 30000
- NUMBER OF STUDENTS YEAR FIVE- The number of students to be trained at location #2 during the first year of training.
- 15) #STUDENTS STEADY STATE  
Integer Value  
from 0 to 30000
- NUMBER OF STUDENTS STEADY STATE- The number of students to be trained at location #2 in a "steady state" year. In a "steady state" year, all of the systems have been fielded and training is strictly concerned with replacing personnel lost from the system via attrition, promotion, and other related factors. (see the procedures guide for more detailed description)
- 16) LOCATION THREE  
Character String  
15 Characters
- LOCATION THREE- Third course location.  
15 characters
- 17) #STUDENTS YEAR ONE  
Integer Value  
from 0 to 30000
- NUMBER OF STUDENTS YEAR ONE- The number of students to be trained at location #3 during the first year of training.
- 18) #STUDENTS YEAR TWO  
Integer Value  
from 0 to 30000
- NUMBER OF STUDENTS YEAR TWO- The number of students to be trained at location #3 during the first year of training.
- 19) #STUDENTS YEAR THREE  
Integer Value  
from 0 to 30000
- NUMBER OF STUDENTS YEAR THREE- The number of students to be trained at location #3 during the first year of training.
- 20) #STUDENTS YEAR FOUR  
Integer Value  
from 0 to 30000
- NUMBER OF STUDENTS YEAR FOUR- The number of students to be trained at location #3 during the first year of training.

## Student Input Reqs Attribute

## Glossary Definition...

- 21) #STUDENTS YEAR FIVE  
Integer Value  
from 0 to 30000
- NUMBER OF STUDENTS YEAR FIVE- The number of students to be trained at loaction #3 during the first year of training.
- 22) #STUDENTS STEADY STATE  
Integer Value  
from 0 to 30000
- NUMBER OF STUDENTS STEADY STATE- The number of students to be trained at location #3 in a "steady state" year. In a "steady state" year, all of the systems have been fielded and training is strictly concerned with replacing personnel lost from the system via attrition, promotion, and other related factors. (see the procedures guide for more detailed description)
- 23) LOCATION FOUR  
Character String  
15 Characters
- LOCATION FOUR- Fourth course location.  
15 characters
- 24) #STUDENTS YEAR ONE  
Integer Value  
from 0 to 30000
- NUMBER OF STUDENTS YEAR ONE- The number of students to be trained at loaction #4 during the first year of training.
- 25) #STUDENTS YEAR TWO  
Integer Value  
from 0 to 30000
- NUMBER OF STUDENTS YEAR TWO- The number of students to be trained at loaction #4 during the first year of training.
- 26) #STUDENTS YEAR THREE  
Integer Value  
from 0 to 30000
- NUMBER OF STUDENTS YEAR THREE- The number of students to be trained at loaction #4 during the first year of training.
- 27) #STUDENTS YEAR FOUR  
Integer Value  
from 0 to 30000
- NUMBER OF STUDENTS YEAR FOUR- The number of students to be trained at loaction #4 during the first year of training.

Student Input Reqs Attribute

Glossary Definition...

28) 8STUDENTS YEAR FIVE  
Integer Value  
from 0 to 30000

NUMBER OF STUDENTS YEAR FIVE- The number of students to be trained at loaction #4 during the first year of training.

29) 8STUDENTS STEADY STATE  
Integer Value  
from 0 to 30000

NUMBER OF STUDENTS STEADY STATE- The number of students to be trained at location #4 in a "steady state" year. In a "eady state" year, all of the systems have been fielded and training is strictly concerned with replacing personnel lost from the system via attrition, promotion, and other related factors. (see the procedures guide for more detailed description)

```

*****
Entity Name      Mbr Type      Glossary Definition...
-----
Course Module   34 Sub-Entity  COURSE MODULE- A module associate with a course.
*****

```

```

Course Module Attribute -----
Glossary Definition... -----

```

1) TITLE  
Character String  
15 Characters

TITLE- Title of course module to be analyzed.  
15 characters

2) LENGTH  
Decimal Value  
width=8 places=2

LENGTH- Length of course in days.  
7 digits, 2 decimal places

3) ALTERNATIVE  
Character String  
10 Characters

ALTERNATIVE- A code used to describe the specific training alternative (if any) with which the module is associated.  
10 characters

4) TASK  
Sub-Entity refers to:  
TASK  
(Limit of 20)

TASK- A list of the Tasks trained in the module. This attribute refers to the TASK entity. Limit 20.

5) INSTRUCTIONAL METHOD 1  
Select from List  
number 15

INSTRUCTIONAL METHOD 1- The primary method of instruction for the module.

6) STUDENT/INSTRUCTOR RATIO  
Integer Value  
from 1 to 254

STUDENT/INSTRUCTOR RATIO- The ratio of students to instructors- for the primary method of instruction.

Course Module Attribute

Blossary Definition...

7) CONTACT HOURS  
 Decimal Value  
 width=8 places=2

CONTACT HOURS- The amount of instructional hours utilizing the method for the identified course module.  
 7 digits, 2 decimal places

8) MEDIA  
 Sub-Entity refers to:  
 MEDIA  
 (Limit of 1)

MEDIA- The primary and secondary media used with the identified method. This attribute refers to the MEDIA entity.

9) INSTRUCTIONAL METHOD 2  
 Select from List  
 number 15

INSTRUCTIONAL METHOD 2- The secondary method of instruction for the module.

10) STUDENT/INSTRUCTOR RATIO  
 Integer Value  
 from 1 to 254

STUDENT/INSTRUCTOR RATIO- The ratio of students to instructors- for the secondary method of instruction.

11) CONTACT HOURS  
 Decimal Value  
 width=8 places=2

CONTACT HOURS- The amount of instructional hours utilizing the method for the identified course module.  
 7 digits, 2 decimal places

12) MEDIA  
 Sub-Entity refers to:  
 MEDIA  
 (Limit of 2)

MEDIA- The primary and secondary media used with the identified method. This attribute refers to the MEDIA entity.

13) INSTRUCTIONAL METHOD 3  
 Select from List  
 number 15

INSTRUCTIONAL METHOD 3- The third method of instruction for the module.

14) STUDENT/INSTRUCTOR RATIO  
 Integer Value  
 from 1 to 254

STUDENT/INSTRUCTOR RATIO- The ratio of students to instructors- for the third method of instruction.

Course Module Attribute  
-----

Glossary Definition...  
-----

15) CONTACT HOURS- The amount of instructional hours utilizing the method for the identified course module.  
Decimal Value width=8 places=2  
7 digits, 2 decimal places

16) MEDIA Sub-Entity refers to:  
MEDIA (Limit of 2)  
MEDIA- The primary and secondary media used with the identified method. This attribute refers to the MEDIA entity.

17) INSTRUCTIONAL METHOD 4 Select from List number 15  
INSTRUCTIONAL METHOD 4- The primary method of instruction for the module.

18) STUDENT/INSTRUCTOR RATIO Integer Value from 1 to 254  
STUDENT/INSTRUCTOR RATIO- The ratio of students to instructors- for the fourth method of instruction.

19) CONTACT HOURS- The amount of instructional hours utilizing the method for the identified course module.  
Decimal Value width=8 places=2  
7 digits, 2 decimal places

20) MEDIA Sub-Entity refers to:  
MEDIA (Limit of 2)  
MEDIA- The primary and secondary media used with the identified method. This attribute refers to the MEDIA entity.

21) INSTRUCTIONAL METHOD 5 Select from List number 15  
INSTRUCTIONAL METHOD 5- The fifth method of instruction for the module.

22) STUDENT/INSTRUCTOR RATIO Integer Value from 1 to 254  
STUDENT/INSTRUCTOR RATIO- The ratio of students to instructors- for the fifth method of instruction.

Course Module Attribute

Glossary Definition...

23) CONTACT HOURS- The amount of instructional hours utilizing the method for the identified course module.  
Decimal Value width=8 places=2  
7 digits, 2 decimal places

CONTACT HOURS  
Decimal Value  
width=8 places=2

24) MEDIA- The primary and secondary media used with the identified method. This attribute refers to the MEDIA entity.

24) MEDIA  
Sub-Entity refers to:  
MEDIA  
(Limit of 2)

INSTRUCTIONAL METHOD 6- The primary method of instruction for the module.

25) INSTRUCTIONAL METHOD 6  
Select from List  
number 15

STUDENT/INSTRUCTOR RATIO- The ratio of students to instructors- for the sixth method of instruction.

26) STUDENT/INSTRUCTOR RATIO  
Integer Value  
from 1 to 254

CONTACT HOURS- The amount of instructional hours utilizing the method for the identified course module.  
7 digits, 2 decimal places

27) CONTACT HOURS  
Decimal Value  
width=8 places=2

MEDIA- The primary and secondary media used with the identified method. This attribute refers to the MEDIA entity.

28) MEDIA  
Sub-Entity refers to:  
MEDIA  
(Limit of 2)

```

*****
Entity Name      Mbr Type      Glossary Definition...
-----

```

```

MISSION 35 Regular MISSION- A general description of the objectives which a system must accomplish.
          (For example, interdiction, target servicing, counterfire)
*****

```

```

MISSION Attribute -----
Glossary Definition...
-----

```

```

1) NAME Character String 39 Characters
NAME- Name of Mission. 15 characters

```

```

2) PERCENT OPERATING TIME Integer Value from 0 to 100
PERCENT OPERATING TIME- That portion or percentage of time the system is
anticipated to spend engaged in a specific mission.

```

```

3) ANNUAL # MISSIONS Integer Value from 0 to 30000
ANNUAL NUMBER OF MISSIONS- Number of times per year the system is expected to
perform a specific mission.

```

```

4) ANNUAL OPERATING DAYS Integer Value from 0 to 30000
ANNUAL OPERATING DAYS- The estimated number of days, per year, the system will
spend engaged in performing a specific mission.

```

```

5) MEAN DURATION Decimal Value width=8 places=2
MEAN DURATION- Average length of time the system spends in accomplishing a
specific mission.
7 digits, 2 decimal places

```

```

6) MEASUREMENT BASE Character String 10 Characters
MEASUREMENT BASE- The unit of measurement used in calculating the mean duration
of the mission (for example, hours, days, months).
10 characters

```

MISSION Attribute  
-----

7) ANN. OPER. DAYS REQB.  
Decimal Value  
width=8 places=2

Glossary Definition...  
-----

ANNUAL OPERATING DAYS REQUIRED- The goal for annual operating days required.  
The number of days, per year, that the system  
must be capable of spending in a specific  
mission.  
7 digits, 2 decimal places

\*\*\*\*\*

Entity Name      Mbr Type      Glossary Definition...

MEDIA      36 Regular      MEDIA- A description of the means for presenting instructional materials to learners (TRADOC 350-20)

MEDIA Attribute      Glossary Definition...

1) TITLE      Character String      35 Characters

2) ALTERNATIVE      Character String      10 Characters  
ALTERNATIVE- A code used to designate the specific training alternative (if any) with which the media is associated.      10 characters

3) NUMBER      Character String      20 Characters  
NUMBER- Primary number used to designate a specific media item.      20 characters

4) ALTERNATIVE NUMBER      Character String      15 Characters  
ALTERNATIVE NUMBER- An additional number for identifying a specific media item.      15 characters

5) ISSUE RATE PER STUDENT      Decimal Value      width=8 places=2  
ISSUE RATE PER STUDENT- The number of media items to be issued to each student. This number may be less than 1 if more than one student is assigned to each media.      7 digits, 2 decimal places

6) PUBLICATION DATE      Character String      12 Characters  
PUBLICATION DATE- The expected or actual publication date of the media (printed media only).      12 characters

MEDIA Attribute  
-----

Glossary Definition...  
-----

- 7) REVISION DATE  
Character String  
12 Characters
- REVISION DATE- The date on which the media was revised or updated.  
12 characters
- 8) DEVELOPMENT COST  
Decimal Value  
width=8 places=2
- DEVELOPMENT COST- The sum of all costs resulting from an applied research, design, analysis, development, test, evaluation, and management development efforts related to a specific media.  
7 digits, 2 decimal places
- 9) INVESTMENT COST  
Decimal Value  
width=8 places=2
- INVESTMENT COST- The sum of all costs resulting from the production and introduction of the media into the Army's operational inventory.  
7 digits, 2 decimal places
- 10) OPERATING & SUPPORT COST  
Decimal Value  
width=8 places=2
- OPERATING & SUPPORT COST- The sum of all costs resulting from the operation, maintenance, and support (including personnel support) of the media after it is accepted into the Army inventory.  
7 digits, 2 decimal places
- 11) UNIT PRICE  
Decimal Value  
width=10 places=2
- UNIT PRICE- The current estimated price for one unit of the media.  
9 digits, 2 decimal places
- 12) COST CATEGORY SIX  
Decimal Value  
width=8 places=2
- COST CATEGORY SIX- An additional cost category to be used by the individual SDI user as he so desires.  
7 digits, 2 decimal places
- 13) COST CATEGORY SEVEN  
Decimal Value  
width=8 places=2
- COST CATEGORY SEVEN- An additional cost category to be used by the individual SDI user as he so desires.  
7 digits, 2 decimal places

MEDIA Attribute  
-----

Glossary Definition...  
-----

14) COST CATEGORY EIGHT  
Decimal Value  
width=8 places=2  
  
COST CATEGORY EIGHT- An additional cost category to be used by the individual  
SDT user as he so desires.  
7 digits, 2 decimal places

15) COST CATEGORY NINE  
Decimal Value  
width=8 places=2  
  
COST CATEGORY NINE- An additional cost category to be used by the individual  
SDT user as he so desires.  
7 digits, 2 decimal places

16) COST CATEGORY TEN  
Decimal Value  
width=8 places=2  
  
COST CATEGORY TEN- An additional cost category to be used by the individual  
SDT user as he so desires.  
7 digits, 2 decimal places

17) COST CATEGORY ELEVEN  
Decimal Value  
width=8 places=2  
  
COST CATEGORY ELEVEN- An additional cost category to be used by the individual  
SDT user as he so desires.  
7 digits, 2 decimal places

18) COST CATEGORY TWELVE  
Decimal Value  
width=8 places=2  
  
COST CATEGORY TWELVE- An additional cost category to be used by the individual  
SDT user as he so desires.  
7 digits, 2 decimal places

19) SPECIFIC TYPE  
Select from List  
number 18  
  
SPECIFIC TYPE- Specific Media Type.

20) MAX DAILY OPER. TIME  
Decimal Value  
width=8 places=2  
  
MAXIMUM DAILY OPERATING TIME- The maximum number of hours per day that the  
media will be available for instructional use  
taking into account facility and personnel  
scheduling constraints and the reliability and  
maintainability of the media hardware and  
software. 7 digits, 2 decimal places

MEDIA Attribute	Glossary Definition...
21) STUDENT/INSTRUCTOR RATIO Integer Value from 1 to 254	STUDENT INSTRUCTOR RATIO- The student/instructor ratio typically associated with the particular media item.
22) NUMBER OF MEDIA - YEAR 1 Integer Value from 0 to 30000	NUMBER OF MEDIA - YEAR 1- The number of media required in the first year of operation.
23) NUMBER OF MEDIA - YEAR 2 Integer Value from 0 to 30000	NUMBER OF MEDIA - YEAR 2- The number of media required in the second year of operation.
24) NUMBER OF MEDIA - YEAR 3 Integer Value from 0 to 30000	NUMBER OF MEDIA - YEAR 3- The number of media required in the third year of operation.
25) NUMBER OF MEDIA - YEAR 4 Integer Value from 0 to 30000	NUMBER OF MEDIA - YEAR 4- The number of media required in the fourth year of operation.
26) NUMBER OF MEDIA - YEAR 5 Integer Value from 0 to 30000	NUMBER OF MEDIA - YEAR 5- The number of media required in the fifth year of operation.
27) NUMBER OF MEDIA - YEAR 6 Integer Value from 0 to 30000	NUMBER OF MEDIA - YEAR 6- The number of media required in the sixth year of operation.
28) NUMBER OF MEDIA - YEAR 7 Integer Value from 0 to 30000	NUMBER OF MEDIA - YEAR 7- The number of media required in the seventh year of operation.

## MEDIA Attribute

## Glossary Definition...

- 29) # OF MEDIA - STEADY STATE  
Integer Value  
from 0 to 30000
- NUMBER OF MEDIA - STEADY STATE- The number of additional media required in the steady state year of operation.
- 30) INDEX OF EFFECTIVENESS  
Decimal Value  
width=8 places=2
- INDEX OF TRAINING DEVICE EFFECTIVENESS- A summary measure of the correspondence between the operational equipment and the media. It is calculated by summing the task commonality, physical similarity, and functional similarity scores and then dividing by three. This score should only be used in conjunction with the ETES training device determination procedures.  
7 digits, 2 decimal places
- 31) OVERALL INDEX OF EFFEC.  
Decimal Value  
width=8 places=2
- OVERALL INDEX OF TRAINING EFFECTIVENESS- An overall measure of the effectiveness of a particular training device. It is calculated by combining the index of training device effectiveness and the index of personnel and training requirements. This index should only be used in conjunction with the ETES training device determination process.  
7 digits, 2 decimal places
- 32) INDEX OF PERSONNEL REPTS  
Decimal Value  
width=8 places=2
- INDEX OF PERSONNEL AND TRAINING REQUIREMENTS- A summary measure of the extent of training required based upon the skill and knowledge requirements and abilities of the typical trainee. It is calculated by adding the skill and knowledge requirements score and the task difficulty score and dividing by two. This index should only be used in conjunction with the ETES training device determination procedures. 7 digits, 2 decimal places
- 33) TASK DATE  
Character String  
12 Characters
- TASK DATE- The date on which the task commonality profile was created.  
12 characters
- 34) FUNCTIONAL DATE  
Character String  
12 Characters
- FUNCTIONAL DATE- The date on which the task functional similarity profile was created.  
12 characters

\*\*\*\*\*  
 Entity Name            Nbr Type            Glossary Definition...  
 -----  
 \*\*\*\*\*

DUTY POSITION            37 Regular            DUTY POSITION- A Description of the individual positions required by system operation and maintenance. A duty Position is a group of closely related tasks and responsibilities which normally are assumed by one individual assigned to a given position in a military unit. A military occupational specialty usually qualifies an individual for a variety of assignments. (TRADOC CIR 350-3)  
 \*\*\*\*\*

DUTY POSITION Attribute            Glossary Definition...  
 -----  
 \*\*\*\*\*

- 1) DUTY POSITION TITLE  
    Character String  
    20 Characters
  
  - 2) DUTY POSITION NUMBER  
    Character String  
    3 Characters
  
  - 3) MOS TITLE  
    Character String  
    18 Characters
  
  - 4) MOS NUMBER  
    Character String  
    3 Characters
  
  - 5) ASI TITLE  
    Character String  
    15 Characters
- DUTY POSITION TITLE- Name of the Duty Position.  
 20 characters
- DUTY POSITION NUMBER- Optional number used to distinguish one duty position from another.  
 3 characters
- MOS TITLE- The name used to identify an MOS.  
 18 characters
- MOS NUMBER- A digit-digit-letter code used to identify a specific MOS.
- ASI TITLE- The name used to describe an ASI.  
 15 characters

DUTY POSITION ATTRIBUTE

Glossary Definition...

- 6) ASI NUMBER  
Character String  
2 Characters
- ASI NUMBER- A d...t-letter code used to designate an ASI.
  
- 7) SKILL LEVEL  
Select from List  
number 53
- SKILL LEVEL- A two digit code used to identify the level of proficiency required for performance of a specific military job, and the level of proficiency at which an individual qualifies in that military occupational specialty. (AR 310-25)
  
- 8) POSITION TYPE  
Select from List  
number 54
- POSITION TYPE- Draft / New / Existing
  
- 9) MANPOWER REQUIREMENTS  
Sub-Entity refers to:  
MANPOWER REQ'RMENTS  
(Single Sub-entity)
- MANPOWER REQUIREMENTS- This attribute is a sub-entity containing the following:  
Start Date  
Manpower Requirements Year 1 through Year 7
  
- 10) TASK  
Sub-Entity refers to:  
TASK  
(Limit of 20)
- TASK- A listing of the tasks associated with a particular duty position. This attribute refers to the the TASK entity.
  
- 11) ORGANIZATION ONE NUMBER  
Character String  
10 Characters
- ORGANIZATION ONE NUMBER- Number used to designate lowest level organization associated with a duty position. (for example, lowest level for operation of a new Howitzer system might be "CREW") By developing a hierarchy of organizations, the location of a duty position within the overall Army organizational structure can be specified.  
10 characters
  
- 12) ORGANIZATION ONE TITLE  
Character String  
20 Characters
- ORGANIZATION ONE TITLE- Name of lowest level organization (for example, tank crew) associated with a duty position.  
20 characters

DUTY POSITION Attribute

Glossary Definition...

- |  |   |
|--|---|
| 13) ORGANIZATION TWO NUMBER<br>Character String<br>10 Characters   | ORGANIZATION TWO NUMBER--<br>Number used to designate second lowest level organization associated with a duty position.<br>10 characters  |
| 14) ORGANIZATION TWO TITLE<br>Character String<br>20 Characters    | ORGANIZATION TWO TITLE--<br>Name of second lowest organization associated with a duty position.<br>20 characters                          |
| 15) ORGANIZATION THREE NUMBER<br>Character String<br>10 Characters | ORGANIZATION THREE NUMBER--<br>Number used to designate third lowest level organization associated with a duty position.<br>10 characters |
| 16) ORGANIZATION THREE TITLE<br>Character String<br>20 Characters  | ORGANIZATION THREE TITLE--<br>Name of third lowest organization associated with a duty position.<br>20 characters                         |
| 17) ORGANIZATION FOUR NUMBER<br>Character String<br>10 Characters  | ORGANIZATION FOUR NUMBER--<br>Number used to designate fourth lowest level organization associated with a duty position.<br>10 characters |
| 18) ORGANIZATION FOUR TITLE<br>Character String<br>20 Characters   | ORGANIZATION FOUR TITLE--<br>Name of fourth lowest organization associated with a duty position.<br>20 characters                         |



MANPOWER REQUIREMENTS Attribute  
-----

7) MANPOWER REQTS - YEAR 6  
Decimal Value  
width=8 places=2

8) MANPOWER REQTS - YEAR 7  
Decimal Value  
width=8 places=2

Glossary Definition...  
-----

MANPOWER REQUIREMENTS - YEAR 6--  
The total number of individuals required in the  
duty position in the sixth year of system  
operation.  
7 digits, 2 decimal places

MANPOWER REQUIREMENTS - YEAR 7--  
The total number of individuals required in the  
duty position in the seventh year of system  
operation.  
7 digits, 2 decimal places

Nbr. Select From  
-----

Glossary Definition...  
-----

8 !-TOOLS-  
!-TEST EQUIPMENT-

9 !DISPLAY  
!CONTROL

10 !OPERATOR  
!PREVENTIVE MAINT.  
!CORRECTIVE MAINT.--CREW  
!CORRECTIVE MAINT.--ORGANIZATIONAL  
!CORRECTIVE MAINT.--DIRECT SUPPORT  
!CORRECTIVE MAINT.--GENERAL SUPPORT  
!SUPPORT

TOOLS- indicates this is a tool.  
TEST EQUIPMENT- indicates this is a test equipment.

DISPLAY- indicates the particular piece of equipment is a display mechanism.  
CONTROL- indicates the particular piece of equipment is a control mechanism.

11 !DRAFT  
!NEW  
!EXISTING

12 !BCT  
!OSUT  
!AIT  
!PLC  
!PTC  
!ANCOC  
!SNCOC  
!SGMA  
!SERVICE SCHOOL  
!SOJT  
!SELF STUDY  
!SCHEDULED TRAINING

OPERATOR-  
PREVENTIVE MAINTENANCE-  
CORRECTIVE MAINTENANCE - CREW-  
CORRECTIVE MAINTENANCE - ORGANIZATIONAL-  
CORRECTIVE MAINTENANCE - DIRECT SUPPORT  
CORRECTIVE MAINTENANCE - GENERAL SUPPORT-  
CORRECTIVE MAINTENANCE - DEPO1-  
SUPPORT-

DRAFT-  
NEW-  
EXISTING-

BCT-  
OSUT-  
AIT-  
PLC-  
PTC-  
ANCOC-  
SNCOC-  
SGMA-  
SERVICE SCHOOL-  
SOJT-  
SELF STUDY-  
SCHEDULED TRAINING-

Nbr. Select From

Glossary Definition...

15	!PE1 - hardware oriented (hands-on)	PE1 - hardware oriented (hands-on)
	!PE2 - nonhardware oriented (nonclass)	PE2 - nonhardware oriented (nonclass)
	!PE3 - classroom practical application	PE3 - classroom practical application
	!SP - self-paced instruction	SP - self-paced instruction
	!E2 - nonhardware performance exam	E2 - nonhardware performance exam
	!E1 - nonhardware performance exam	E1 - nonhardware performance exam
	!E3 - written examination	E3 - written examination
	!C - conference/lecture	C - conference/lecture
	!D - demonstration	D - demonstration
	!F - film	F - film
	!TV - television	TV - television
	!CAI - computer assisted instruction	CAI - computer assisted instruction
	!PI - programmed instruction (text)	PI - programmed instruction (text)
	!S - seminar	S - seminar
	!CS - case study	CS - case study
	!EL - elective (in-house except CGSB)	EL - elective (in-house except CGSB)
	!GS - guest speaker	GS - guest speaker
	!DF - dual flight hours (only aviator)	DF - dual flight hours (only aviator)
	!SF - solo flight hours (only aviator)	SF - solo flight hours (only aviator)
18	11.1 TECHNICAL MANUALS (TM)	1.1 TECHNICAL MANUALS (TM)
	11.2 FIELD MANUALS (FM)	1.2 FIELD MANUALS (FM)
	11.3 UARMY REGULATIONS (AR)	1.3 UARMY REGULATIONS (AR)
	11.4 DEPT OF ARMY PAMS (DA-PAM)	1.4 DEPT OF ARMY PAMS (DA-PAM)
	11.5 LUBRICATION ORDERS (LO)	1.5 LUBRICATION ORDERS (LO)
	11.6 TECHNICAL BULLETIN (TB)	1.6 TECHNICAL BULLETIN (TB)
	11.7 SUPPLY CATALOG	1.7 SUPPLY CATALOG
	11.8 SUPPLY BULLETIN	1.8 SUPPLY BULLETIN
	11.9 SOLDIERS MANUAL	1.9 SOLDIERS MANUAL
	11.10 COMMANDER'S MANUAL	1.10 COMMANDER'S MANUAL
	11.11 ARTEP MANUAL	1.11 ARTEP MANUAL
	11.12 TECHNICAL CIRCULAR	1.12 TECHNICAL CIRCULAR
	11.13 OTHER-C	1.13 OTHER-C
	11.14 OTHER-D	1.14 OTHER-D
	11.15 OTHER-E	1.15 OTHER-E

Nbr. Select From

Glossary Definition...

13.1	PRINTED TEXT-TEC	3.1	PRINTED TEXT-TEC
13.2	VIDEO TAPE-TEC	3.2	VIDEO TAPE-TEC
13.3	AUDIO-TEC	3.3	AUDIO-TEC
13.4	AUDIOVISUAL-TEC	3.4	AUDIOVISUAL-TEC
13.5	JOB PERFORMANCE AID-TEC	3.5	JOB PERFORMANCE AID-TEC
13.6	PRINTED LESSON-ETH	3.6	PRINTED LESSON-ETH
13.7	AUDIOVISUAL-ETH	3.7	AUDIOVISUAL-ETH
13.8	JOB PERFORMANCE GUIDE-ETH	3.8	JOB PERFORMANCE GUIDE-ETH
13.9	35MM SLIDES-ETH	3.9	35MM SLIDES-ETH
13.10	STUDENT GUIDE-ETH	3.10	STUDENT GUIDE-ETH
13.11	MANAGER'S GUIDE-ETH	3.11	MANAGER'S GUIDE-ETH
14.1	ACTUAL EQUIPMENT WITH SIMUL.CAPAB.	4.1	ACTUAL EQUIPMENT WITH SIMUL.CAPAB.
14.2	ACTUAL EQUIPMENT	4.2	ACTUAL EQUIPMENT
15.1	MOCKUPS, PANELS, DEMOS-STATIC	5.1	MOCKUPS, PANELS, DEMOS-STATIC
15.2	MOCKUPS, PANELS, DEMOS-DYNAIC	5.2	MOCKUPS, PANELS, DEMOS-DYNAIC
15.3	PART TASK TRAINER	5.3	PART TASK TRAINER
15.4	WHOLE TASK TRAINER	5.4	WHOLE TASK TRAINER
15.5	WEAPON SYSTEM TRAINER	5.5	WEAPON SYSTEM TRAINER
15.6	OTHER-A	5.6	OTHER-A
15.7	OTHER-B	5.7	OTHER-B
15.8	OTHER-C	5.8	OTHER-C
16.1	TRAINING FILMS/VIDEOTAPED	6.1	TRAINING FILMS/VIDEOTAPED
16.2	GRAPHIC TRAINING AIDS	6.2	GRAPHIC TRAINING AIDS
17.1	COMPUTER	7.1	COMPUTER
17.2	TERMINALS	7.2	TERMINALS
17.3	PERIPHERALS	7.3	PERIPHERALS
17.4		7.4	
17.5		7.5	
17.6		7.6	
17.7		7.7	
17.8		7.8	
17.9		7.9	
17.10		7.10	
18.1		8.1	
18.2		8.2	
18.3		8.3	

Nbr. Select Fron  
-----  
Glossary Definition...  
-----

- 18.4
- 18.5
- 18.6
- 18.7
- 18.8
- 18.9
- 18.10
- 18.11
- 18.12

21 NO SIGNIFICANT DIFFERENCE  
SMALL DIFFERENCE  
MODERATE DIFFERENCES  
LARGE DIFFERENCES  
EXTREMELY SIGNIFICANT DIFFERENCES

NO SIGNIFICANT DIFFERENCE-  
SMALL DIFFERENCE-  
MODERATE DIFFERENCES-  
LARGE DIFFERENCES-  
EXTREMELY SIGNIFICANT DIFFERENCES

22 HIGH  
MEDIUM  
LOW

HIGH-  
MEDIUM-  
LOW

23 SUPERVISORY  
TEAM PERFORMANCE  
INDIVIDUAL PERFORMANCE

SUPERVISORY- The trainee's function is unequal to functions being performed by other individuals; the role is basically one of overseeing or directing.  
TEAM PERFORMANCE- The trainee's function is equal to functions being performed by other individuals; the function is basically one of team-work and cooperation.  
INDIVIDUAL PERFORMANCE- The trainee's function is one of performing alone, usually without supervision or team assistance.

24 MENTAL  
PHYSICAL

MENTAL- An action occurring or experienced in the trainee's mind, as contrasted with overt physical activity.  
PHYSICAL- An overt bodily action performed by the trainee.

Nbr. Select From  
-----

Glossary Definition...  
-----

PERCEPTUAL  
COMMUNICATIVE  
;

PERCEPTUAL- An action by the trainee involving perception or observation.  
COMMUNICATIVE- An action by the trainee in which he transmits either a written or verbal message.

25 UNSTABLE  
;  
STABLE

UNSTABLE- The trainee's activity is not constant or regular, it is characterized by continual change and fluctuation.  
STABLE- The trainee's activity has little change or fluctuation over time.

26 LOW IMPACT  
;  
HIGH IMPACT  
;

LOW IMPACT- The physical environment has little or no significant impact on performance of the task.  
HIGH IMPACT- The physical environment has a large or significant impact on performance of the task.

27 LOW IMPACT  
;  
HIGH IMPACT  
;

LOW IMPACT- The psychological environment has little or no significant impact on performance of the task.  
HIGH IMPACT- The psychological environment has a large or significant impact on performance of the task.

28 VISUAL CUES  
AUDIO CUES  
TACTILE CUES  
;  
;  
EXTERNAL STIMULUS  
;  
;  
;  
INTERNAL STIMULUS  
;  
;  
OLFACTILE CUES  
GUSTATILE CUES

VISUAL CUES- Signals received through the sense of sight.  
AUDIO CUES- Signals received through the sense of hearing.  
TACTILE CUES- Signals received through the sense of touch, including sensations related to texture, size, shape, or vibration of the skin.  
EXTERNAL STIMULUS MOTION CUES- The sensations felt by a person when he is moved by some outside force in such a way that his body experiences roll, pitch, yaw, heave, sway and/or surge.  
INTERNAL STIMULUS MOTION CUES- The sensations felt by a person when he moves his arm, leg, fingers, etc.  
OLFACTILE CUES- Signals received through the sense of smell.  
GUSTATILE CUES- Signals received through the sense of taste.

Nbr. Select From

Glossary Definition...

- 29 |ALPHANUMERIC- Words and/or numbers presented visually.  
 |SYMBOLIC- Symbols presented graphically.  
 |GRAPHIC- Two-dimensional figures, such as maps, graphs, mathematical  
 | curves, etc., presented visually.  
 |PICTORIAL- Two dimension images, such as photographs, drawings, etc.,  
 | presented visually.  
 |SOLID OBJECT- A three-dimensional image or reality that is viewed from  
 | exterior perspectives.  
 |ENVIRONMENT- A three-dimensional image or reality that is viewed  
 | from inside.
- 30 |STILL- static visual field, as with a still photograph, drawing or  
 | printed page.  
 |LIMITED MOVEMENT- A basically static visual field with elements that can  
 | be made to move, as with an animated transparency or simple  
 | panel with switches that move.  
 |FULL MOVEMENT- A visual field in which all elements can move, as with a  
 | motion picture, flight simulator, or operational aircraft.  
 |CYCLIC MOVEMENT- A visual field which moves through a fixed sequence and  
 | then repeats the sequence in a repetitive manner, as with  
 | a film loop.
- 31 |BLACK AND WHITE- A visual field composed of either black or white elements,  
 | as with the printed page or line drawings.  
 |GRAY SCALE- A visual field composed of black, white and continuous gradations  
 | of gray, as with a black and white photograph or television  
 | picture.  
 |COLOR- A visual field composed of various segments of the visual spectrum,  
 | as with color television or motion pictures.
- 32 |EXACT SCALE- Actual visual field or a one-to-one replication of that field  
 | as with a full-sized mock-up, simulator, or operational system.  
 |PROPORTIONAL SCALE- A representation of reality in other than full scale, such  
 | as a scaled model map or photograph.

Nbr. Select From  
-----Glossary Definition...  
-----

- 33 !DIM- A visual object which blends in with its background, i.e., there is a  
! small or no luminance difference between an object and its background.  
! BRIGHT- A visual object which is brighter than its background, i.e., there is  
! a large luminance difference between an object and its background.
- 34 ! TONAL SOUND- A very limited source of sound or noise which is used, rather  
! than speech, for signalling or warning, e.g., horns, whistles,  
! sirens, bells, buzzers, etc.  
! VOICE SOUND- A limited source of sound which enables spoken words to be used  
! as the medium of communications, but not suited to more demanding  
! tasks, such as music or sound recognition exercises.  
! FULL SOUND- A source of sound that contains all the significant elements of the  
! sound and is suited to the demanding task of sound recognition  
! exercises.  
! AMBIENT SOUND- A complex sound environment with sounds emanating from various  
! sources and from various directions, including background noise  
! and task significant sounds.
- 35 !WEAK- Audio stimuli presented to the trainee which have weak intensity.  
! STRONG- Audio stimuli presented to the trainee which have strong intensity.
- 36 !STATIC- A unitary stimuli situation, i.e., stimuli are presented to the trainee  
! "all at once", e.g., batch presentation.  
! DYNAMIC-ORDERED A sequential stimuli situation, i.e., stimuli are presented  
! to the trainee sequentially or in an ordered manner over time.  
! DYNAMIC-RANDOM A non-sequential stimuli situation, i.e., stimuli are presented  
! to the trainee randomly over time.
- 37 !SLOW RATE- A slow rate or speed of presentation of stimuli to the trainee,  
! allowing the trainee a long or maximum stimulus analysis time.

Nbr. Select From  
-----Glossary Definition...  
-----

- FAST RATE- A fast rate or speed of presentation of stimuli to the trainee, allowing the trainee a short or minimum stimulus analysis time.
- LIMITED- A small number of sources, channels, or instruments through which stimuli are presented to the trainee.
- UNLIMITED- A multiple number of sources, channels, or instruments through which stimuli are presented to the trainee.
- VERBAL- A response which the trainee expresses in an audible (verbal) manner, such as a verbal short answer response to a question having a limited set of correct answers, a conversational response, or a verbal decision response.
- WRITTEN- A response which the trainee expresses in an observable (written) manner, such as a free style written response, a written multiple choice response, or a written fill-in-the-blank response.
- MANIPULATIVE ACTS- A response which the trainee expresses in an observable (manipulative) manner, such as the small movements of dials, switches, or keys, or small adjustments to instruments or the large movements of levers, wheels or use of hand held tools.
- TRACKING- A response which the trainee expresses in an observable (tracking) manner, such as continuously controlling a constantly changing system, e.g., steering an automobile.
- PROCEDURAL PERFORMANCE- A response which the trainee expresses in an observable (procedural performance) manner, such as performing a sequence of steps in a procedure, e.g. carrying out the items on the checklist for preflighting an aircraft or turning on a radar system.
- WEAK- Responses made by the trainee with weak intensity.
- STRONG- Responses made by the trainee with strong intensity.

Nbr. Select From  
-----Glossary Definition...  
-----

41	!STATIC	A unitary response situation, i.e., responses are made by the trainee "all at once".
	!DYNAMIC-ORDERED	A sequential response situation, i.e., responses are made by the trainee sequentially or in an ordered manner over time.
	!DYNAMIC-RANDOM	A non-sequential response situation, i.e., responses are made by the trainee randomly over time.
42	!SLOW RATE	A slow rate or speed of trainee response, i.e., a rate which allows the trainee a long or maximum response time.
	!FAST RATE	A fast rate or speed of trainee response, i.e., a rate which allows the trainee a short or minimum response time.
43	!LIMITED	A limited number of sources, channels, or instruments through which required responses are made by the trainee.
	!UNLIMITED	An unlimited number of sources, channels, or instruments through which responses are made by the trainee.
44	!INDIVIDUAL	One individual trainee makes the required response.
	!GROUP	A group of trainees makes the required response.
45	!VISUAL	Feedback presented visually by means of a display, it may be coded and transmitted visually to the trainee.
	!AURAL	Feedback presented aurally by means of a display to the trainee.
	!WRITTEN FORM	Feedback presented to the trainee in written form.
	!FACE-TO-FACE	Feedback presented by direct verbal means to the trainee.
	!INDIRECT	Feedback presented by indirect verbal means, such as by intercom, telephone, or radio link.
	!TACTILE	Feedback presented to the trainee through the sense of touch, including sensations related to texture, shape, size, or vibration of the skin.
	!KINESTHETIC	Feedback presented to the trainee by either internal or external bodily movement, such as reaching, grasping, tilting, etc.



Nbr. Select From

Glossary Definition...

49 ENTRY LEVEL  
: TRAINED

ENTRY LEVEL- Entry level skill/knowledge  
TRAINED- Skill/Knowledge trained in system

50 INDIVIDUAL  
: GROUP

INDIVIDUAL- All information is presented directly to one individual trainee.  
GROUP- Information is presented to a group of trainees, allowing only indirect access to the information for an individual.

51 PROPOSED  
: MODIFIED  
: EXISTING

PROPOSED- Proposed  
MODIFIED- Modified/Existing  
EXISTING- Existing

52 YES  
: NO

YES- Quarters and Mess are available.  
NO- Quarters and Mess are not available.

53 10  
: 20  
: 30  
: 40  
: 50

10- Ten  
20- Twenty  
30- Thirty  
40- Forty  
50- Fifty

54 DRAFT  
: NEW  
: EXISTING

DRAFT-  
NEW-  
EXISTING-

**THIS PAGE INTENTIONALLY LEFT BLANK**

## APPENDIX B

This appendix describes standard output reports that are included in the SDT. A listing of the output reports and the attributes they include is presented in Table B-1. Examples of each format follow this table.

Table B-1. Standard SDT Output Formats.

REPORT	DATA ELEMENTS	TOTAL COLUMN WIDTH
<b><u>FUNCTIONS</u></b>		
• SIMPLE FUNCTION LISTING	FUNCTION NUMBER, FUNCTION NAME	80
• COLLECTIVE TASKS BY FUNCTION	FUNCTION NUMBER, FUNCTION NAME, COLLECTIVE TASK NAME	80
• FUNCTION SEQUENCE	FUNCTION NUMBER, FUNCTION NAME, PRECEDING FUNCTION, SUCCEEDING FUNCTION	80
• TASKS BY FUNCTION	FUNCTION NUMBER, FUNCTION NAME, TASK NAME, TASK NUMBER	80
• EQUIPMENTS BY FUNCTION	FUNCTION NUMBER, FUNCTION NAME, EQUIPMENT #, EQUIPMENT NAME	80
• FUNCTION PERFORMANCE GOALS	FUNCTION NUMBER, FUNCTION NAME, PERFORMING MEASURE, GOAL/STANDARD	80
• ENVIRONMENTAL IMPACTS	FUNCTION NUMBER, FUNCTION NAME, ENVIRONMENTAL VARIABLE, VARIABLE IMPACTED, REFERENCE	80
• THREAT IMPACT	FUNCTION NUMBER, FUNCTION NAME, THREAT VARIABLE, VARIABLE IMPACTED, REFERENCE	80
• MISSION IMPACTS ON FUNCTIONS	FUNCTION NUMBER, FUNCTION NAME, MISSION IMPACT VARIABLE, VARIABLE IMPACTED, REFERENCE	80
<b><u>EQUIPMENTS</u></b>		
• SIMPLE EQUIPMENT LISTING	EQUIPMENT NUMBER, EQUIPMENT NAME	80
• TASKS BY EQUIPMENT	EQUIPMENT NUMBER, EQUIPMENT NAME, TASK NUMBER, TASK NAME	80
• EQUIPMENT RELIABILITY DATA	EQUIPMENT NUMBER, EQUIPMENT NAME, MTBF, MTTR, MTBMA	80
• NUMBER OF ITEMS SUPPORTED	EQUIPMENT NUMBER, EQUIPMENT NAME, # CREW, # ORGANIZATIONAL, # DS, # DEPOT	80
• COMPARABLE EQUIPMENT BY EQUIPMENT	EQUIPMENT NUMBER, EQUIPMENT NAME, COMPARABLE EQUIPMENT, AMOUNT OF DIFFERENCE	80
• GENERIC EQUIPMENT LISTING	EQUIPMENT NUMBER, GENERIC EQUIPMENT, EXISTING EQUIPMENT	80
• INFORMATION INPUTS AND OUTPUTS	EQUIPMENT NUMBER, EQUIPMENT NAME, INFORMATION INPUT, INPUT SOURCE, INFORMATION OUTPUT, OUTPUT SOURCE	80
• EQUIPMENT COSTS	EQUIPMENT NUMBER, EQUIPMENT NAME, R&D COST, INVEST. COST, O&S COST, UNIT PRICE, CAT 5 COST, CAT 6 COST, CAT 7 COST, CAT 8 COST, CAT 9 COST	80
• SIMPLE TASK LISTING	TASK NUMBER, TASK NAME	80
• TASK ELEMENTS	TASK NUMBER, TASK NAME, TASK ELEMENT NAME	80
• TASK CONDITIONS AND STANDARDS	TASK NUMBER, TASK NAME, TASK CONDITIONS, TASK STANDARDS, AMOUNT VALUE	80
• EXTENDED TASK DESCRIPTION	TASK NAME, TASK TYPE, TASK STATUS, WORK AREA, TASK AREA, AMOUNT OF SUPERVISION, NUMBER OF PERFORMING	80

Table B-1. Standard SDT Output Formats. (continued)

REPORT	DATA ELEMENTS	TOTAL COLUMN WIDTH
<u>EQUIPMENTS (continued)</u>		
• TASK SEQUENCE INFORMATION	TASK NUMBER, TASK NAME, PRECEDING TASK, SUCCEEDING TASK	80
• INITIATING AND TERMINATING CUES	TASK NUMBER, TASK NAME, INITIATING CUE, AND ASSOCIATED EQUIPMENT, TERMINATING CUE AND ASSOCIATED EQUIPMENT	80
• FAILURE MODES	TASK NUMBER, TASK NAME, FAILURE, % OF FAILURES	80
• TOOLS AND TEST EQUIPMENT	TASK NUMBER, TASK NAME, TOOLS/TEST EQUIPMENT, NUMBER, TYPE	80
• SKILLS AND KNOWLEDGES	TASK NUMBER, TASK NAME, SKILL/KNOWLEDGE, TYPE, CATEGORY, SKILL AND KNOWLEDGE CHARACTERISTIC ONE, SKILL AND KNOWLEDGE CHARACTERISTIC TWO	80
• LEARNING OBJECTIVES	TASK NUMBER, TASK NAME, LEARNING OBJECTIVE CHARACTERISTICS ONE AND TWO	80
• PERFORMANCE MEASURES	TASK NUMBER, TASK NAME, PERFORMANCE MEASURE, AMOUNT/VALUE	80
• TRAINING EMPHASIS RATINGS	TASK NUMBER, TASK NAME, % PERFORMING, % TIME, CONSEQUENCES OF INADEQUATE, TASK DELAY TOLERANCE, LEARNING DIFFICULTY, FREQUENCY OF PERFORMANCE, TIME BETWEEN ENTRY AND PERFORMANCE	80
• STIMULI - (PARTS 1 AND 2)	TASK NUMBER, TASK NAME, STIMULUS VARIABLES FROM ETES MEDIA SELECTION PROGRAM	80
• RESPONSES	TASK NUMBER, TASK NAME, RESPONSE VARIABLES, ETES MEDIA SELECTION PROGRAM	80
• FEEDBACK	TASK NUMBER, TASK NAME, FEEDBACK VARIABLES FROM ETES MEDIA SELECTION PROGRAM	80
<u>COURSES</u>		
• COURSE LISTING	COURSE NUMBER, COURSE TITLE	80
• COURSE DESCRIPTION	COURSE NUMBER, COURSE TITLE, COURSE LENGTH, COURSE TYPE, ALTERNATIVE, STATUS, COMPARABLE COURSE, COMPARABLE COURSE NUMBER	80
• COURSE SCENARIO AND RESOURCE INFORMATION	COURSE NUMBER, COURSE TITLE, COURSE LENGTH, ATTRITION RATE, CLASS SIZE, FREQUENCY, NUMBER OF NORM GRADS, QUARTERS/MESS AVAILABLE, PER CENT OFFICERS, PER CENT TDY, INSTRUCTOR CONTACT HOURS PER CLASS, NUMBER OF INSTRUCTIONS, P8 REQUIREMENTS	80
• YEARLY STUDENT INPUTS (YSI)	COURSE NUMBER, COURSE TITLE, COURSE LENGTH, LOCATION, YSI-YEAR 1, YSI-YEAR 2, YSI-YEAR 3, YSI-YEAR-4, YSI-YEAR 5, YSI-STEADY STATE	80
• COURSE COSTS	COURSE NUMBER, COURSE TITLE, 23 COST VARIABLES	80
• QUASI-POI: PART 1	COURSE NUMBER, COURSE TITLE, MODULE TITLE, METHODS WITHIN MODULES, CONTACTS HOURS PER METHOD, STUDENT/INSTRUCTOR RATIO PER METHOD	80
• QUASI-POI: PART 2	COURSE NUMBER, COURSE TITLE, MODULE TITLE, TASKS	80

Table B-1. Standard SDT Output Formats. (continued)

REPORT	DATA ELEMENTS	TOTAL COLUMN WIDTH
<p><u>COURSES (continued)</u></p>		
<ul style="list-style-type: none"> <li>• MEDIA BY COURSE</li> </ul>	<p>COURSE NUMBER, COURSE TITLE, MODULE TITLE, MEDIA</p>	80
<p><u>MISSIONS</u></p>		
<ul style="list-style-type: none"> <li>• MISSION PROFILE</li> </ul>	<p>MISSION NAME, ANNUAL NUMBER OF MISSIONS, ANNUAL OPERATING DAYS, MEAN DURATION, ANNUAL OPERATING DAY REQUIREMENTS</p>	80
<p><u>MEDIA</u></p>		
<ul style="list-style-type: none"> <li>• MEDIA DESCRIPTION</li> </ul>	<p>MEDIA TITLE, ALTERNATIVE, MEDIA NUMBER, ISSUE RATE PER STUDENT, PUBLICATION DATE, REVISION DATE, MEDIA TYPE-GENERAL, MEDIA TYPE-SPECIFIC, MAXIMUM DAILY OPERATING TIME, STUDENT INSTRUCTOR RATIO, INDEX OF EFFECTIVENESS, OVERALL INDEX OF EFFECTIVENESS, INDEX OF PERSONNEL REQUIREMENTS</p>	80
<ul style="list-style-type: none"> <li>• MEDIA COSTS</li> </ul>	<p>MEDIA NAME, 12 COST VARIABLES</p>	80
<ul style="list-style-type: none"> <li>• NUMBER OF MEDIA</li> </ul>	<p>MEDIA NAME, NUMBER IN YEARS ONE THROUGH SEVEN AND STEADY STATE</p>	80
<ul style="list-style-type: none"> <li>• DUTY POSITION DESCRIPTIONS</li> </ul>	<p>DUTY POSITION TITLE, DUTY POSITION NUMBER, MOS TITLE, MOS NUMBER, ASI TITLE, ASI NUMBER, SKILL LEVEL</p>	80
<ul style="list-style-type: none"> <li>• MANPOWER REQUIREMENTS</li> </ul>	<p>DUTY POSITION TITLE, MOS NUMBER, ASI NUMBER, START DATE, MANPOWER REQUIREMENTS IN YEARS ONE THROUGH SEVEN</p>	80
<ul style="list-style-type: none"> <li>• TASKS BY DUTY POSITION</li> </ul>	<p>DUTY POSITION TITLE, MOS NUMBER, ASI NUMBER, TASK NUMBER, TASK TITLE</p>	80
<ul style="list-style-type: none"> <li>• ORGANIZATIONAL REQUIREMENTS</li> </ul>	<p>DUTY POSITION TITLE, MOS NUMBER, ASI NUMBER, NUMBERS AND TITLES FOUR LEVELS OF ORGANIZATION</p>	80

**TABLE B-2**

**LIST OF OUTPUT REPORTS**

SIMPLE FUNCTION LISTING

NUMBER

FUNCTION

COLLECTIVE TASKS BY FUNCTION

NUMBER  
-----

FUNCTION  
-----

COLLECTIVE TASK NAME  
-----



FUNCTION SEQUENCE

NUMBER:  
NAME:

<u>PREC. #</u>	<u>PRECEDING FUNCTION</u>	<u>SUCC. #</u>	<u>SUCCEEDING FUNCTION</u>
----------------	---------------------------	----------------	----------------------------



EQUIPMENTS BY FUNCTION

NUMBER:

NAME:

EQUIP. # -----	EQUIPMENT -----
-------------------	--------------------

TASKS BY FUNCTION

NUMBER:

NAME:

TASK  
-----



FUNCTION PERFORMANCE GOALS

NUMBER:

NAME:

PERFORMANCE MEASURE

GOAL/STANDARD

ENVIRONMENTAL IMPACTS

• NUMBER:  
NAME:

ENVIRONMENTAL VARIABLE .  
-----

VARIABLE IMPACTED  
-----

REFERENCE  
-----



THREAT IMPACTS

NUMBER:  
NAME:

THREAT VARIABLE  
-----

VARIABLE IMPACTED  
-----

REFERENCE  
-----



MISSION IMPACTS

NUMBER:

NAME:

MISSION IMPACT VARIABLE REFERENCE

MISSIONS IMPACTED

-----

-----



SIMPLE EQUIPMENT LISTING

NUMBER -----	EQUIPMENT -----	FGC/WBC/WUC -----	MFG. PART # -----
-----------------	--------------------	----------------------	----------------------



TASKS BY EQUIPMENT

NUMBER:  
NAME:

<u>TASK #</u>	<u>TASK</u>
---------------	-------------



EQUIPMENT RELIABILITY DATA

NUMBER  
-----

EQUIPMENT  
-----

MTBF  
-----

MTTR  
-----

MTBMA  
-----



NUMBER SUPPORTED

NUMBER

EQUIPMENT

#CREW

#ORG

#DS

#DEPOT



GENERIC EQUIPMENT LISTING

GENERIC EQUIPMENT

EQUIP. #

EQUIPMENT

-----

-----

-----



INFORMATION INPUTS AND OUTPUTS

NUMBER:  
NAME:

INFORMATION INPUT  
-----

SOURCE  
-----

INFORMATION OUTPUT  
-----

SOURCE  
-----



EQUIPMENT COSTS

NUMBER:

NAME:

RESEARCH & DEVELOPMENT COST:

INVESTMENT COST:

OPERATING & SUPPORT COST:

UNIT PRICE:

COST CATEGORY FIVE:

COST CATEGORY SIX:

COST CATEGORY SEVEN:

COST CATEGORY EIGHT:

COST CATEGORY NINE:

COST CATEGORY TEN:

COST CATEGORY ELEVEN:

COST CATEGORY TWELVE:

SIMPLE TASK LISTING

<u>TASK NUMBER</u>	<u>TASK</u>
--------------------	-------------



TASK ELEMENTS

ENLISTED TASK NO.:

TITLE:

TASK ELEMENT

-----



TASK CONDITIONS AND STANDARDS

ENLISTED TASK NO.:  
TITLE:

TASK CONDITION  
-----

STANDARD  
-----

AMT/VALUE  
-----

EXTENDED TASK DESCRIPTION

ENLISTED TASK NO.:

TITLE:

TYPE:

STATUS:

WORK AREA:

TASK AREA:

AMOUNT OF SUPERVISION:

NUMBER PERFORMING:

TASK SEQUENCE INFORMATION

ENLISTED TASK NO.:

TITLE:

PRECEDING TASKS

SUCCEEDING TASKS



INITIATING AND TERMINATING CUES

ENLISTED TASK NO.:  
TITLE:

INITIATING CUE

EQUIPMENT

TERMINATING CUE

EQUIPMENT



FAILURE MODES

ENLISTED TASK NO. :  
TITLE:

FAILURE MODE  
-----

% FAILURES  
-----



TOOLS AND TEST EQUIPMENT

ENLISTED TASK NO.:  
TITLE:

TOOL/TEST EQUIPMENT

NUMBER

INDICATOR



SKILLS AND KNOWLEDGES

ENLISTED TASK NO.:  
TITLE:

SKILL/KNOWLEDGE -----	TYPE -----	CAT. -----	CHAR1 -----	CHAR2 -----	CHAR3 -----	CHAR4 -----	CHAR5 -----
--------------------------	---------------	---------------	----------------	----------------	----------------	----------------	----------------



LEARNING OBJECTIVES

ENLISTED TASK NO.:  
TITLE:

LEARNING OBJECTIVE  
-----

CHAR1 CHAR2 CHAR3 CHAR4  
-----



PERFORMANCE MEASURES

ENLISTED TASK NO.:  
TITLE:

PERFORMANCE MEASURE

AMOUNT/VALUE

TRAINING EMPHASIS RATINGS

ENLISTED TASK NO.:  
TITLE:

% PERF.   % TIME   CONSEQ.   TASK DIF.   PROB. DEF.   ENTRY TIME   FREQ

STIMULI- PART 1

ENLISTED TASK NO.:

TITLE:

MEDIUM

V-FORM

V-SPECTRUM V-SCALE

V-CONTRAS A-SOURCE

A-INTEN.

PRESENTA

RESPONSES

ENLISTED TASK NO.:

TITLE:

MODE	INTENSITY	IMPLEMENT.	REQ. RATE	# CHANNELS	DISTRIBUTION
-----	-----	-----	-----	-----	-----

STIMULI- PART 2

ENLISTED TASK NO.:

TITLE:

PRES-RATE # CHANNEL DISTRIB.

-----



FEEDBACK

ENLISTED TASK NO. :  
TITLE:

MEDIUM	SOURCE	TYPE	DISTRIBUTION
-----	-----	-----	-----

COURSE TITLE

COURSE NUMBER

COURSE TITLE



COURSE DESCRIPTION

COURSE NUMBER:  
TITLE:  
COURSE LENGTH:  
TYPE:  
ALTERNATIVE:  
STATUS:  
COMPARABLE COURSE:  
COMPARABLE NUMBER:

PREREQUISITE COURSES

FOLLOW -ON COURSES

COURSE RESOURCE AND SCENARIO INFORMATION

COURSE NUMBER:  
TITLE:  
COURSE LENGTH:  
ATTRITION RATE:  
CLASS FREQUENCY:  
# NORM GRADUATES:  
QUARTERS/MESS AVAILABLE:  
PERCENT OFFICER GRADUATES:  
PERCENT TDY-STATUS GRADS:  
ICH PER CLASS:  
NUMBER OF INSTRUCTORS:  
MAN-DAYS P8 TROOP SUPPORT:  
MAN-DAYS P2/3 SUPPORT:



YEARLY STUDENT INPUTS

COURSE NUMBER:  
TITLE:  
COURSE LENGTH:  
LOCATION ONE:  
LOCATION TWO:

1-YR1 1-YR2 1-YR3 1-YR4 1-YR5      2-YR1 2-YR2 2-YR3 2-YR4 2-YR5  
-----



YEARLY STUDENT INPUTS

COURSE NUMBER:

TITLE:

COURSE LENGTH:

LOCATION ONE:

LOCATION TWO:

1-YR1	1-YR2	1-YR3	1-YR4	1-YR5	2-YR1	2-YR2	2-YR3	2-YR4	2-YR5
-------	-------	-------	-------	-------	-------	-------	-------	-------	-------

## COURSE COSTS

INSTRUCTIONAL DEPT (OMA):	895
INSTRUCTIONAL DEPT (MPA):	1932
FLYING HOUR COST (OMA):	
FLYING HOUR COST (MPA):	
DIRECT MISSION OTHER (OMA):	804
DIRECT MISSION OTHER (MPA):	888
P8 TROOP SUPPORT (OMA):	
P8 TROOP SUPPORT (MPA):	
P8 TROOP SUPPORT (PA):	
P2/S TROOP SUPPORT (OMA):	
P2/S TROOP SUPPORT (MPA):	
P2/S TROOP SUPPORT (MPA):	
P2/S TROOP SUPPORT (PA):	
AMMUNITION COST/STUDENT:	1087
EQUIP DEPREC. PER GRAD:	
OFFICER PAY AND ALL.:	
ENLISTED PAY AND ALL.:	6244
TRAVEL PAY TO COURSE (OMA):	12
TRAVEL PAY TO COURSE (MPA):	12
PER DIEM AT COURSE:	
BASE OPERATIONS (OMA):	4238
BASE OPERATIONS (OMA):	4238
BASE OPERATIONS (MPA):	1141
TRAINING AIDS (OMA):	281
TRAINING AIDS (MPA):	81
OTHER SUPPORT COSTS (OMA):	1029
OTHER SUPPORT COSTS (MPA):	988
OTHER SUPPORT COSTS (FHMA):	75

### TOTAL COURSE COSTS

AVERAGE COST PER GRADUATE:	19380
DIRECT FIXED COST (OMA):	722
DIRECT FIXED COST (MPA):	1832
DIR. VARIABLE COST (OMA):	917
DIR. VARIABLE COST (MPA):	1469
TOTAL FIXED COST (OMA):	8966
TOTAL FIXED COST (MPA):	2362
TOTAL VARIABLE COST (OMA):	3171
TOTAL VARIABLE COST (MPA):	8669



QUASI POI (PART 1)

COURSE NUMBER:  
TITLE:  
COURSE LENGTH:

<u>MODULE</u>	<u>METH-1</u> <u>S/I</u> <u>ICH</u>	<u>METH-2</u> <u>S/I</u> <u>ICH</u>	<u>METH-3</u> <u>S/I</u> <u>ICH</u>
---------------	-------------------------------------	-------------------------------------	-------------------------------------



QUASI POI (PART 2)

COURSE NUMBER:  
TITLE:

MODULE            TASK  
-----            -----



MEDIA BY COURSE

COURSE NUMBER:  
TITLE:

MODULE                    MEDIA  
-----                    -----



MISSION PROFILE

<u>MISSION</u>	<u>% OP.</u>	<u>AN.#</u>	<u>AN.DAYS</u>	<u>DURATION</u>	<u>MEAS.</u>	<u>BASE</u>	<u>AN.OP.</u>	<u>REQS</u>
----------------	--------------	-------------	----------------	-----------------	--------------	-------------	---------------	-------------



MEDIA DESCRIPTION

TITLE:  
ALTERNATIVE:  
NUMBER:  
ALTERNATIVE NUMBER:  
ISSUE RATE PER STUDENT:  
PUBLICATION DATE:  
REVISION DATE:  
SPECIFIC TYPE:  
STUDENT/INSTRUCTOR RATIO:  
INDEX OF EFFECTIVENESS:  
OVERALL INDEX OF EFFEC.:  
INDEX OF PERSONNEL REQTS:



MEDIA COSTS

TITLE:  
DEVELOPMENT COST:  
INVESTMENT COST:  
OPERATING & SUPPORT COST:  
UNIT PRICE:  
COST CATEGORY SIX:  
COST CATEGORY SEVEN:  
COST CATEGORY EIGHT:  
COST CATEGORY NINE:  
COST CATEGORY TEN:



NUMBER OF MEDIA

TITLE:

# YR1 # YR2 # YR3 # YR4 # YR5 # YR6 # YR7 #-STEADY STATE

-----



DUTY POSITION DESCRIPTIONS

DUTY POSITION TITLE:  
DUTY POSITION NUMBER:  
MOS TITLE:  
MOS NUMBER:  
MOS NUMBER:  
ASI TITLE:  
ASI NUMBER:  
SKILL LEVEL:



MANPOWER REQUIREMENTS

DUTY POSITION

MOS SKILL

ASI MNPR-YR1

MNPR-YR2

MNPR-YR3

MNPR-YR4

MNPR-YR5



TASKS BY DUTY POSITION

DUTY POSITION

MOS SKILL

ASI TASK



ORGANIZATIONAL REQUIREMENTS

DUTY POSITION TITLE:

MOS NUMBER:

SKILL LEVEL:

ASI NUMBER:

ORGANIZATION-1

ORGANIZATION-2

ORGANIZATION-3

ORGANIZATION-4