

AD-A142 815

PROTOTYPE EVALUATION OF SLUICeway AERATION SYSTEM LIBBY 1/1

DAM KOOTENAI RIVER MONTANA(U) ARMY ENGINEER WATERWAYS

EXPERIMENT STATION VICKSBURG MS HYDRA.. R G MCGEE

UNCLASSIFIED

MAR 84 WES/TR/HL-84-2

F/G 13/13

NL

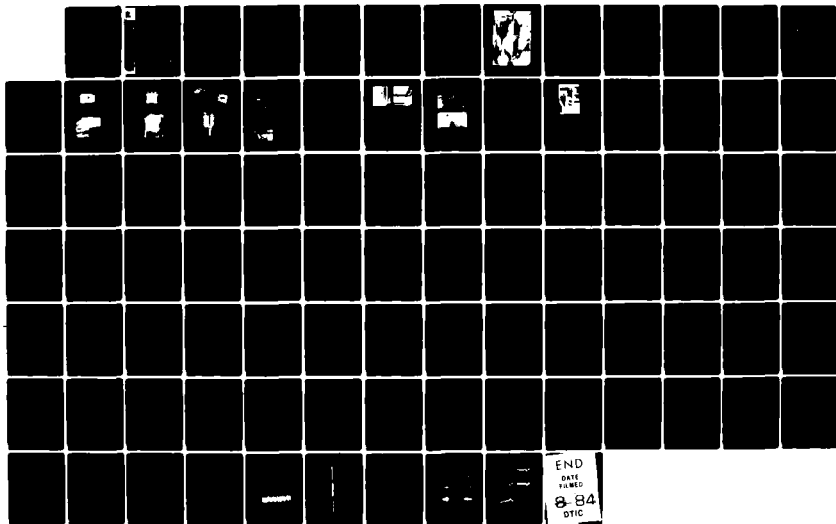

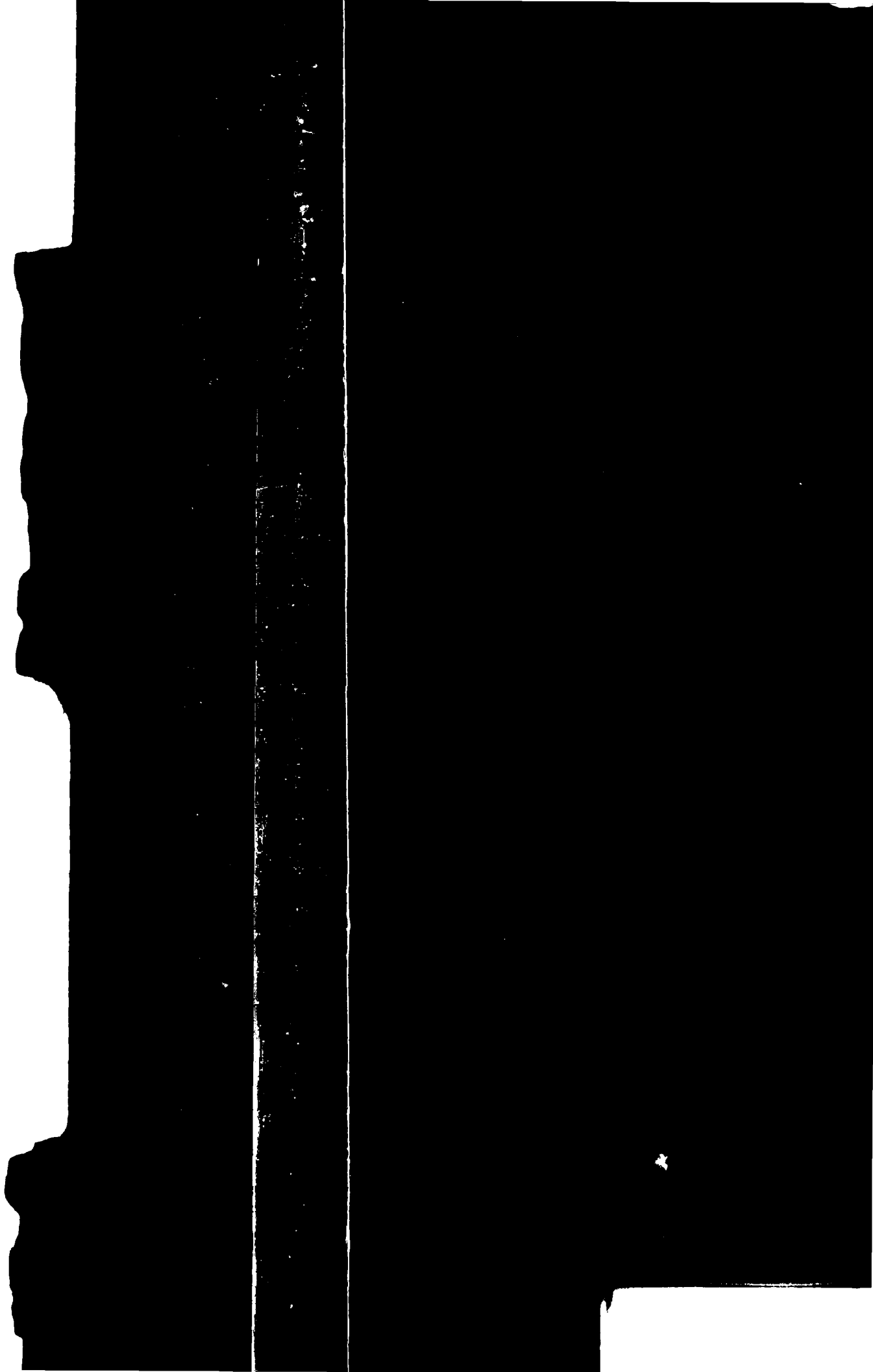

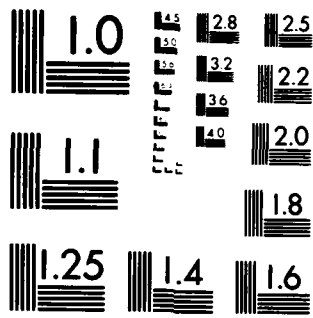

MICROCOPY RESOLUTION TEST CHART
NATIONAL BUREAU OF STANDARDS-1963-A

12

TECHNICAL REPORT NO. 84-2



US Army Corps of Engineers

PROTOTYPE EVALUATION OF SLUICeway AERATION SYSTEM LIBBY DAM, KOOTENAI RIVER, MONTANA

Report No. 84-2

Hydraulic Engineering Division

U. S. Army Engineer District, Seattle
P. O. Box 631, Victoria, B.C. V8N 1B6

AD-A142 815



March 1984

Final Report

Approved For Public Release

DTIC FILE COPY

DTIC
SERIALS
JUL 10 1984
S D
E



Prepared for U. S. Army Engineer District, Seattle
Seattle, Wash. 98124

84 07 10 084

Unclassified

SECURITY CLASSIFICATION OF THIS PAGE (When Data Entered)

REPORT DOCUMENTATION PAGE		READ INSTRUCTIONS BEFORE COMPLETING FORM
1. REPORT NUMBER Technical Report HL-84-2	2. GOVT ACCESSION NO. A142815	3. RECIPIENT'S CATALOG NUMBER
4. TITLE (and Subtitle) PROTOTYPE EVALUATION OF SLUICWAY AERATION SYSTEM, LIBBY DAM, KOOTENAI RIVER, MONTANA	5. TYPE OF REPORT & PERIOD COVERED Final report	
	6. PERFORMING ORG. REPORT NUMBER	
7. AUTHOR(s) Richard G. McGee	8. CONTRACT OR GRANT NUMBER(s)	
9. PERFORMING ORGANIZATION NAME AND ADDRESS U. S. Army Engineer Waterways Experiment Station Hydraulics Laboratory P.O. Box 631, Vicksburg, Miss. 39180	10. PROGRAM ELEMENT, PROJECT, TASK AREA & WORK UNIT NUMBERS	
11. CONTROLLING OFFICE NAME AND ADDRESS U. S. Army Engineer District, Seattle P.O. Box C-3755 Seattle, Wash. 98124	12. REPORT DATE March 1984	
	13. NUMBER OF PAGES 88	
14. MONITORING AGENCY NAME & ADDRESS (if different from Controlling Office)	15. SECURITY CLASS. (of this report) Unclassified	
	15a. DECLASSIFICATION/DOWNGRADING SCHEDULE	
16. DISTRIBUTION STATEMENT (of this Report) Approved for public release; distribution unlimited.		
17. DISTRIBUTION STATEMENT (of the abstract entered in Block 20, if different from Report)		
18. SUPPLEMENTARY NOTES Available from National Technical Information Service, 5285 Port Royal Road, Springfield, Va. 22161		
19. KEY WORDS (Continue on reverse side if necessary and identify by block number) Prototypes, Engineering Water--Air entrainment Sluice gates Dams--Montana--Models Libby Dam (Mont.)		
20. ABSTRACT (Continue on reverse side if necessary and identify by block number) Tests were conducted to make a comprehensive prototype evaluation of the postmodification (i.e., aerator installation and air vent streamlining) operat- ing conditions of the project. Prototype measurements included air vent dis- charges, center sluice aerator slot pressures, and invert pressures acting along the center line of the center sluice. Pressure drops from the atmosphere to the right and center sluice gate chambers were measured along with the (Continued)		

Unclassified

SECURITY CLASSIFICATION OF THIS PAGE(When Data Entered)

20. ABSTRACT (Continued).

pressure acting on the modified wall separating the center sluice gate chamber from the lower service gallery. In addition, vertical, transverse, and longitudinal structure accelerations were measured in the vicinity of the center sluice gate and on the sluice emergency gate during an emergency gate lowering operation.

Results of the data reduction indicated a virtual elimination of the cavitation-inducing negative pressures on the center sluice invert that existed prior to the installation of the aeration system. An increase in airflow occurred through the air vents during combined spillway-sluice flow due to hindrance of ventilation through the exit portal. Unsteady airflow (gusting) existed in each air vent and ranged, on the average, +25 percent of mean flow at a frequency of approximately 0.4 cps. Data also indicated that unequal service gate operation may cause different airflows than uniform gate operation. Except for the head loss through the right sluice vent, maximum recorded air vent velocities and head losses exceeded the limits suggested in EM 1110-2-1602. The recorded pressures acting on the service gallery wall were less than the design value. Structural vibrations were generally insignificant during all tests. The emergency gate was subjected to significant vibrations during the unsuccessful emergency gate closure.

Unclassified

SECURITY CLASSIFICATION OF THIS PAGE(When Data Entered)

PREFACE

The prototype tests described herein were conducted during September 1982 by the U. S. Army Engineer Waterways Experiment Station (WES) under the sponsorship of the U. S. Army Engineer District, Seattle.

The overall test program was conducted under the general supervision of Messrs. H. B. Simmons, Chief of the Hydraulics Laboratory, and M. B. Boyd, Chief of the Hydraulic Analysis Division. Mr. R. G. McGee, Engineer, Prototype Evaluation Branch, was the test coordinator. This report was prepared by Mr. McGee under the supervision of Mr. E. D. Hart, Chief of the Prototype Evaluation Branch. Instrumentation support was provided by Messrs. W. Guy and R. Floyd, under the supervision of Mr. L. M. Duke, Chief of the Operations Branch, Instrumentation Services.

Acknowledgment is made to the personnel of the Seattle District for their assistance in the investigation.

Commander and Director of WES during the investigation and the preparation and publication of this report was COL Tilford C. Creel, CE. Technical Director was Mr. F. R. Brown.

Accession For	
NTIS GRA&I	<input checked="" type="checkbox"/>
DTIC TAB	<input type="checkbox"/>
Unannounced	<input type="checkbox"/>
Justification	
By _____	
Distribution/	
Availability Codes	
Dist	Avail and/or Special
A-1	



CONTENTS

	<u>Page</u>
PREFACE	1
CONVERSION FACTORS, U. S. CUSTOMARY TO METRIC (SI)	
UNITS OF MEASUREMENT	3
PART I: INTRODUCTION	5
Pertinent Features of the Project	5
Spillway and Outlet Works	6
Purpose and Scope of Tests	6
PART II: TEST FACILITIES, EQUIPMENT, AND PROCEDURES	9
Test Facilities	9
Other Measurements	16
Test Equipment	16
Test Procedures	18
PART III: TEST RESULTS AND ANALYSIS	20
Air Discharge	20
Differential Pressures	31
Lower Service Gallery Wall Pressures	31
Sluice Invert Pressures	32
Vibration of Structure	34
Emergency Gate Test	35
PART IV: CONCLUSIONS	38
REFERENCES	40
TABLES 1-19	
PLATES 1-24	

CONVERSION FACTORS, U. S. CUSTOMARY TO METRIC (SI)
UNITS OF MEASUREMENT

U. S. customary units of measurement used in this report can be converted to metric (SI) units as follows:

<u>Multiply</u>	<u>By</u>	<u>To Obtain</u>
acre-feet	1233.482	cubic metres
cubic feet per second	0.02831685	cubic metres per second
feet	0.3048	metres
feet per second	0.3048	metres per second
feet per second per second	0.3048	metres per second per second
inches	25.4	millimetres
inches per second	25.4	millimetres per second
miles (U. S. statute)	1.609344	kilometres
pounds (force) per square inch	6894.757	pascals
square feet	0.09290304	square metres



Figure 1. Libby Dam and Reservoir

PROTOTYPE EVALUATION OF SLUICeway AERATION SYSTEM

LIBBY DAM, KOOTENAI RIVER, MONTANA

PART I: INTRODUCTION

Pertinent Features of the Project

1. Libby Dam (Figure 1) is located on the Kootenai River in northwestern Montana 221.9* river miles** upstream from its confluence with the Columbia River and approximately 17 river miles above the town of Libby, Montana (Figure 2). It is a multipurpose project constructed as an integral unit of the comprehensive water resource development plan of the Columbia River Basin in the United States and Canada.

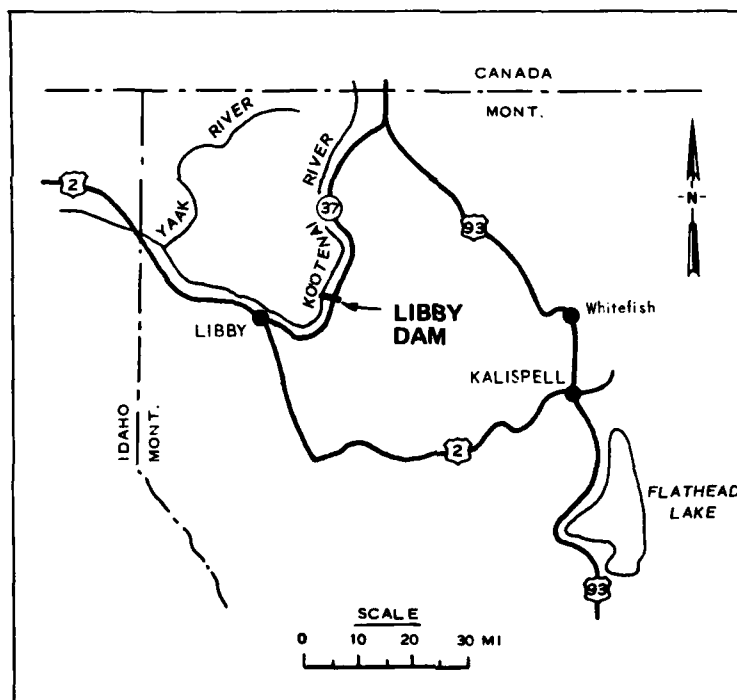

Figure 2. Vicinity map

* Based on official river miles. Previous publications list the dam location as river mile 219.0.

** A table of factors for converting U. S. customary units of measurement to metric (SI) units is given on page 3.

2. The existing project consists of a concrete gravity structure, a reservoir (Lake Koochanusa) having a total gross capacity of 5,870,000 acre-ft at maximum lake elevation 2459 ft NGVD,* and a hydropower installation of five 105,000-kw units. Ultimate hydropower will include eight units. The maximum length of the lake is 90 miles (42 of which extend into Canada). The lake provides 4,980,000 acre-ft of flood storage.

Spillway and Outlet Works

3. Desired flow through the structure is accomplished by means of a two-bay ogee spillway over which flow is controlled by two 48-ft-wide by 56-ft-high tainter gates and three sluices, each 10 ft wide by 22 ft high, controlled by 10-ft-wide by 17-ft-high tainter gates. Both the spillway and sluices empty into the same hydraulic jump-type stilling basin with sloping end sill and no baffles.

Purpose and Scope of Tests

Background

4. Libby Dam became operational in March 1972. Major cavitation damage occurred in the center and right sluices in September 1973 and July 1974, respectively. Following repairs to the center sluice, the U. S. Army Engineer District, Seattle, requested the U. S. Army Engineer Waterways Experiment Station (WES) Hydraulics Laboratory to conduct field measurements to determine the pressures acting on the invert of the center sluice. Tests were conducted in 1974 and a report of findings was published in 1976 (Hart and Tool 1976). With this information as reference material, WES conducted a model study of the sluice (Dortch 1976). As a result, an aerator device was designed that would aerate the flow along the sluice boundaries without adversely affecting flow conditions.

5. The recommended aeration system consists of a slot in both sidewalls and the floor of each sluice as shown in Plate 1. Upon request by the Seattle District, tests were conducted in 1980 to measure the air demand during the operation of the modified sluices and a report of findings was published

* All elevations (el) cited herein are in feet referred to the National Geodetic Vertical Datum (NGVD).

(Hart 1981). Data derived from the test program were used as criteria for design of a more efficient air vent system.

6. The resulting modification to the air vent system was designed to create individual air vents for each sluice, as opposed to the interconnected air vent system initially used at Libby Dam, by streamlining the transition from the air vents to the crossover conduits that lead to the center sluice gate chamber as shown in Figure 3. The modification consists of a splitter plate in the air vents to divert airflow directly into the 4- by 4-ft crossover conduit and into the respective outboard gate chamber (Plate 1). The Seattle District requested a proposal to measure the postmodification airflow through the vent system along with the now-existing sluice invert pressures.

Purpose

7. The primary purpose of the test program was to conduct a comprehensive prototype evaluation of the postmodification (i.e. aerator installation and air vent streamlining) operating conditions of the project. The WES test program included measurement of (a) air vent discharge into the right and center sluices, (b) pressures existing in the aerator slot of the center sluice, and (c) resulting invert pressures acting along the center line of the center sluice. Pressure drops from the atmosphere to the right and center sluice gate chambers were measured along with the pressure acting on the modified wall separating the center sluice gate chamber from the lower service gallery. In addition, accelerometer measurements were taken to determine the vibration frequency and magnitude of the concrete structure in the vicinity of the center sluice gate during sluice operation and of the sluice emergency gate during an emergency gate lowering procedure.

Scope

8. Four series of tests (A, B, C, and D), each performed under different flow conditions, were conducted at Libby Dam during 21-22 September 1982. Series A was conducted with center sluice discharge only; Series B was conducted with center sluice discharge and spillway discharge; Series C was conducted with all three sluices operating uniformly; and Series D utilized all three sluices and spillway flow. Each series covered a full range of sluice gate openings at 2-ft increments from 1 to 15 ft at an average pool elevation of 2458. An additional test, referred to as Series E, was conducted by lowering the emergency gate in the center sluice. During this test, the sluice service gate was opened to 11 ft with no discharge over the spillway.

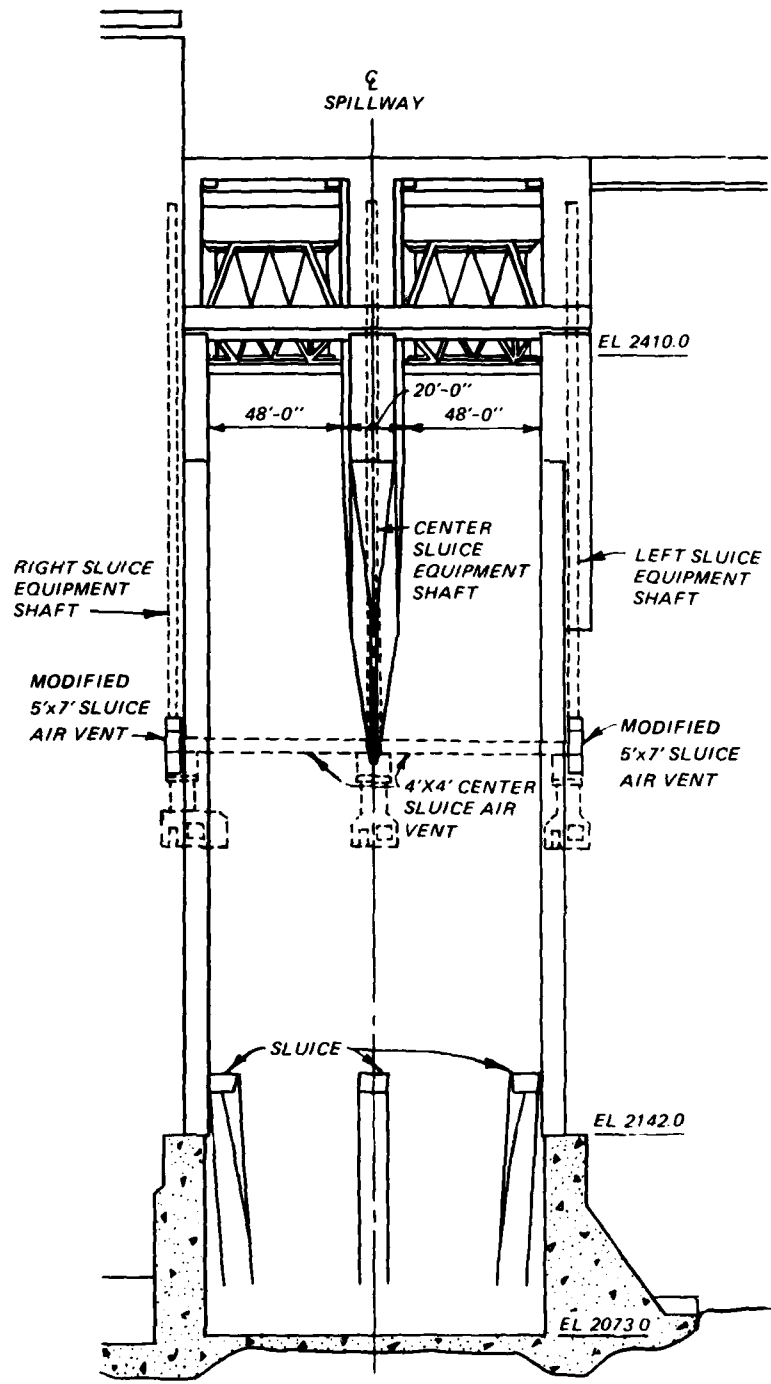

Figure 3. Air vent system, looking upstream

PART II: TEST FACILITIES, EQUIPMENT, AND PROCEDURES

Test Facilities

9. Locations of the test instrumentation are shown in Plates 1-5. The different types of transducers used in the measurements described herein are shown in Figure 4, and the specifics of each transducer are listed in Table 1.

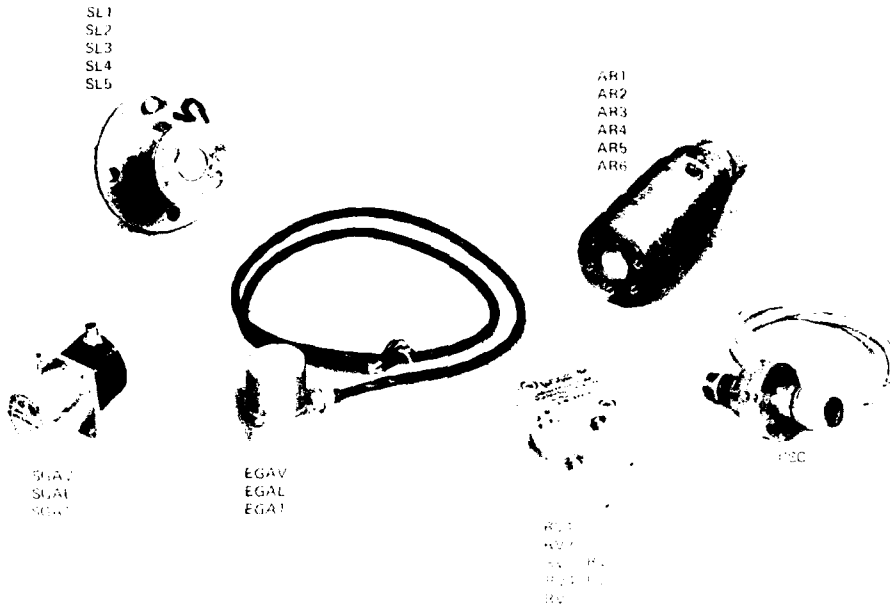

Figure 4. Test instrumentation (scale in centimetres)

Air velocity

10. Air vent design. The original air vent system supplied air to the sluices through two 5- by 7-ft conduits connecting the outboard sluice gate chambers with the atmosphere at the downstream face of the dam. Air was supplied to the center sluice by 4- by 4-ft crossover conduits connecting the center sluice gate chamber with the outboard sluice gate chambers (Figure 3). Because an extremely unstable and possibly insufficient amount of air was being supplied to the center sluice through this interconnected vent system, the design and construction of an independent air vent for the center sluice were accomplished.

11. Location of the spillway precluded duplicating the outboard air

vent geometry. The existing center sluice routing was made independent by directly connecting the crossover conduits with the upper one-third of each outboard air vent. This was accomplished by installing a splitter plate extending the entire length of each air vent and connecting this upper portion to the crossover conduits with a streamlined 90-deg bend gradually expanding from 12 sq ft (area of each upper vent) to 16 sq ft (area of each crossover conduit). This modification, shown in Plate 2, almost equally distributes the total available cross-sectional area of airflow among all sluices and creates independent air vents for each sluice. Figures 5 and 6 show the upper and lower portion of the vents created by the splitter plate leading to the center and right sluices, respectively.

12. Instrumentation. Pitot tube differential pressures were measured at the locations listed in Table 1 and shown in Plate 1 for determining the air velocities in the air vents. Special struts (Plate 2) were fabricated to house the instrumentation used in acquiring the necessary data. Pitot tubes extended downstream and upstream (water flow) for detecting flow into and out of the air vents, respectively.

13. The struts consisted of two halves, bolted together, with intersections removed to accommodate the pitot tubes, pressure transducers, electrical cables, and plastic tubing. Strut brackets were fabricated to attach to the air vent walls for encasing the air vent strut ends. After bolting brackets in place, setscrews were used to hold the struts securely in place. The electrical cables that exited from the end of the struts were attached to anchor bolts in the reach within the vent. Figure 7 shows an air vent strut with its instrumentation exposed and also the same strut installed with brackets and accompanying secured cables.

Aerator slot pressures

14. The aerator (Dortch 1976) basically consists of two parts, the slot and the deflector. The deflector, located on the upstream side, has a height of 1.5 in. above the invert of the sluice with a deflection angle of 3.18 deg and is provided to create a low pressure region in the slot and to prevent water flow from entering the slot. The slot, approximately 2.5 ft deep by 3 ft wide, extends along the floor and both walls of the sluice. The passage permits a sufficient flow of air (drawn by the negative pressure) from the gate chamber to aerate the flow along the downstream boundaries of the sluice. Aerator details are shown in Plate 3.

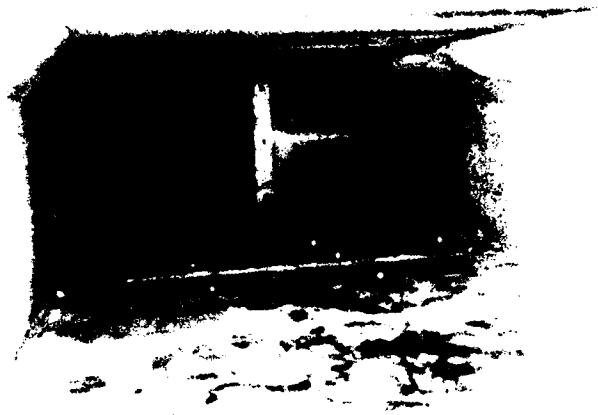

a. Center sluice (upper) air vent



b. Transition from upper air vent to crossover conduit

Figure 5. Upper portion of air vent to center sluice



a. Right sluice air vent



b. Streamlined air vent exit portal into right gate chamber

Figure 6. Air vent modification to right sluice

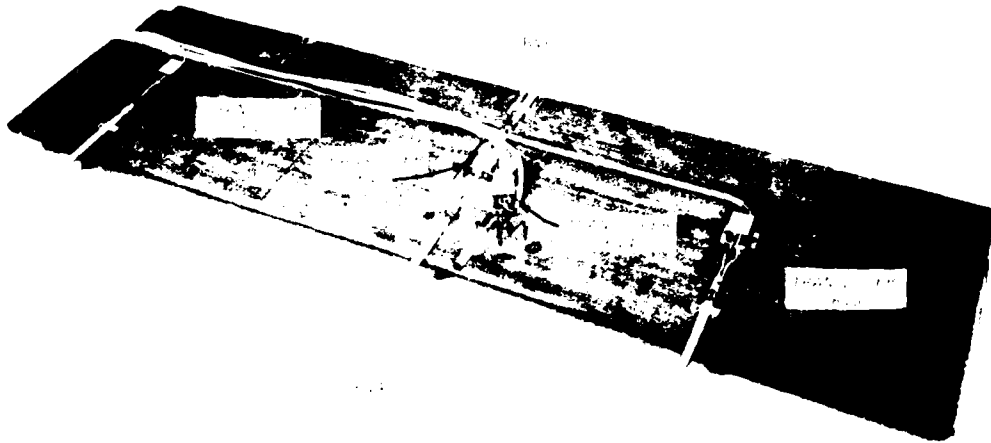

a. Right sluice air vent strut instrumentation exposed



b. Right sluice air vent strut installed (looking upstream)

Figure 7. Right sluice air vent strut (RV3, 4, 5, 6)

15. Six pressure transducer mounting boxes were installed in the center sluice aerator slot as shown in Plates 1 and 3. Two interchangeable cover plates were fabricated for each mounting box, one for a permanent cover and one for WES to install the pressure transducer just prior to testing. Three were located in the slot in the right wall (looking downstream) and three in the floor along the center line of the sluice. Figure 8 shows the aerator slot transducers located in the floor during installation.



Figure 8. Aerator slot pressure transducers (AR4, 5, 6)

16. The transducer cables passed from the mounting boxes through embedded electrical conduit upward to the center sluice gate chamber. Junctions

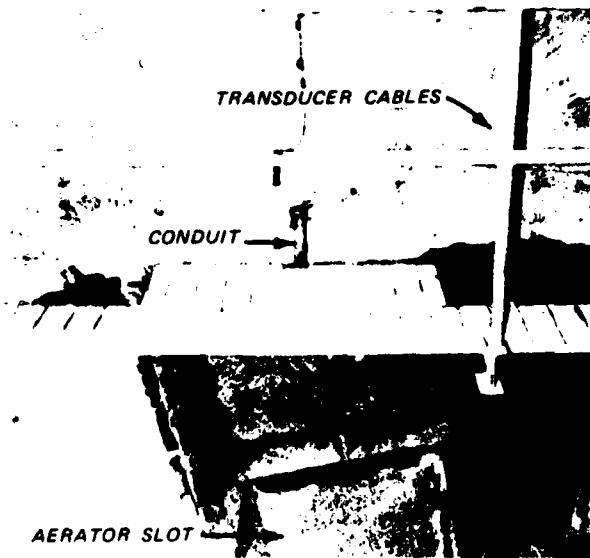

Figure 9. Entrance to aerator slot

in the center mounting box of each transducer cluster allowed all cables to be fed through a common conduit terminating above the aerator slot. Figure 9 shows the entrance to the aerator slot and the transducer cable conduit terminating in the gate chamber.

Sluice pressures

17. Pressure transducer mounting boxes were installed in the floor of the center sluice at the locations shown in Plate 4 for the center sluice investigation

conducted prior to the aerator installation (Hart and Tool 1976). These same facilities were utilized for this test program with transducers being placed at locations SL1-SL5 (Plate 4) along the center line of the sluice invert. Location SL6 could not be instrumented as proposed because of blockage in its cable passage. The transducer cables were passed through the existing drilled holes into the drainage gallery at el 2081.5 and routed to the monitoring station.

Gate chamber pressures

18. Pressure in the gate chambers of the center and right sluices was measured with differential pressure transducers, GCC and GCR, and with an absolute pressure transducer, CSC. A description of the transducers is given in Table 1 and the location of each is shown in Plate 1.

19. The purpose of the differential pressure transducers was to measure the drop in pressure from the atmosphere to the aerator. The transducer for the right sluice (GCR) was attached to the handrail directly above the entrance to the aerator and the center sluice transducer (GCC) was placed on the walkway floor directly adjacent to the aerator entrance. One port of each transducer measured the pressure at the aerator and the other was exposed to atmospheric pressure in the service gallery by 1/4-in.-inside-diam tubing.

20. Transducer CSC was used to measure the pressure acting on the modified service gallery wall for the center sluice gate chamber. The transducer was located inside the gate chamber on a handrail next to the wall door. Figure 10 shows the wall and transducer CSC.

Structure and emergency gate vibrations

21. Structure vibrations in the vicinity of the center sluice gate were measured with a cluster of three accelerometers, SGAV, SGAT, SGAL, measuring accelerations in the vertical, transverse (perpendicular to flow), and longitudinal (upstream/downstream) directions, respectively. The cluster was located directly over the center sluice on the service gallery floor at el 2240.25 (Plate 1). An identical cluster, housed in a waterproof canister, was epoxied to an interior beam of the emergency gate as shown in Plate 5. The transducer cables passed to the top through 3-in. drain holes in each beam of the gate and then down a utility shaft to the monitoring station. Figure 11 shows the accelerometer clusters on the gallery floor and the emergency gate.

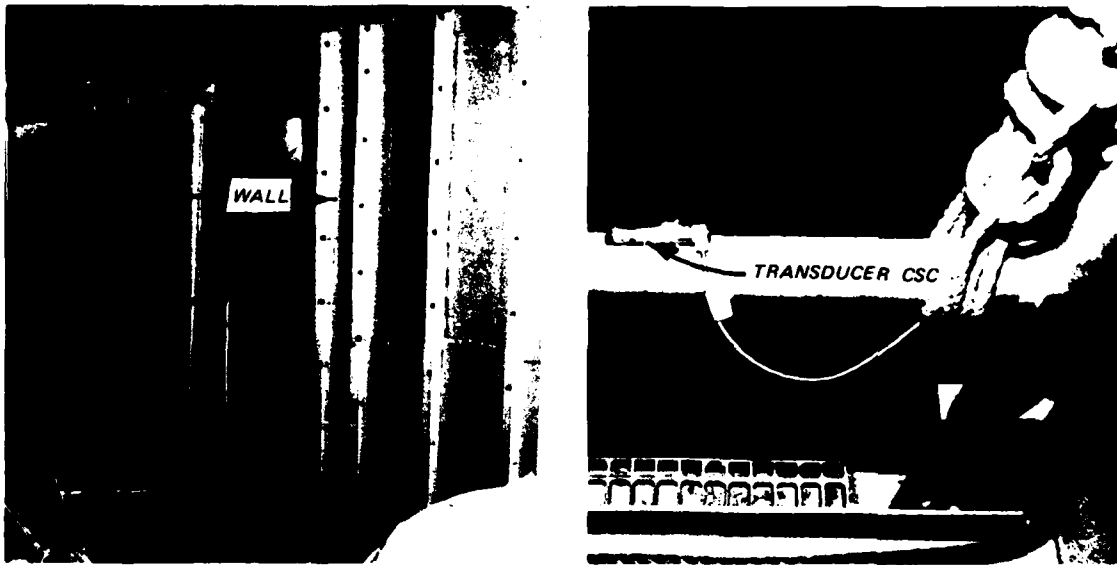

Figure 10. Modified lower service gallery wall and transducer CSC

Other Measurements

22. Other recorded data consisted of reservoir water-surface elevation, air temperature, gate opening, and water discharge. These data were provided by project and District personnel. Water discharge data were provided by the Seattle District and are based on correlation of prototype gate setting with the USGS stream gage immediately downstream of the project.

Test Equipment

23. The test equipment listed and described herein includes the transducers, cables, and recording equipment. Transducers used in the test were as follows:

- a. Air velocity (pitot tube pressure differential): ± 0.5 psid pressure transducers.
- b. Aerator slot pressures: ± 15 psia pressure transducers.
- c. Sluice invert pressures: 100 psia pressure transducers.
- d. Gate chamber pressures.
 - (1) Differential (center sluice): ± 5 psid pressure transducer.

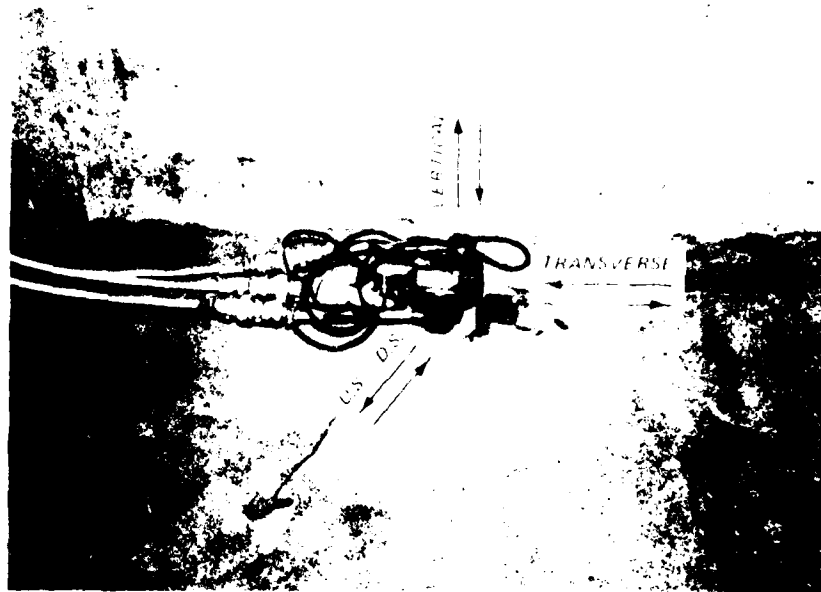

a. Accelerometers attached to service gallery floor at el 2240.25

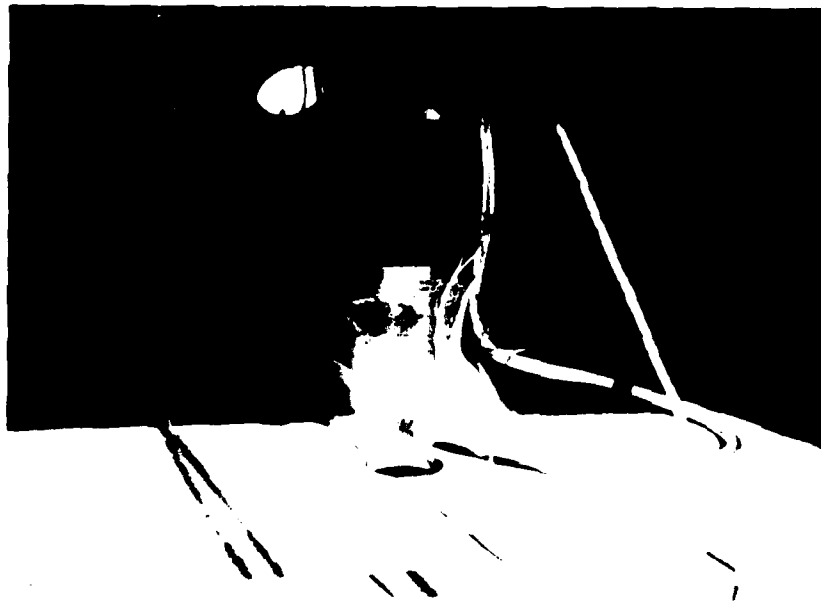

b. Accelerometer canister attached to emergency gate

Figure 11. Accelerometer clusters on gallery floor and emergency gate

- (2) Differential (right sluice): ± 0.5 psid pressure transducer.
- (3) Lower service gallery wall: ± 15 psia pressure transducer.

e. Vibrations (accelerometers).

- (1) Service gallery: 0.01 g to 50 g servo-accelerometers.
- (2) Emergency gate: ± 5 g accelerometers.

24. Cable lengths required for the test program were determined from contract drawings and actual measurements at the project. These cable lengths (listed in Table 1) were cut and used in the calibration of their corresponding transducers to account for line losses. Almost 2.5 miles of cable was required for the Libby Dam test program.

25. The recording equipment consisted of: (a) WES-fabricated model 01, 02, and 03 bridge amplifiers to condition transducer output signals, (b) WES-fabricated calibration panel, (c) a Sangamo model Sabre III, 32-track magnetic-tape recorder with a frequency response from DC to 40 kHz, (d) a CEC model 5-119, 12-in. chart, oscillograph capable of reproducing 36 channels of data at a paper speed from 0.25 ips to 160 ips at a frequency response of DC to 40 kHz, (e) CEC model 7-363 galvanometers, (f) WES-fabricated galvanometer-driver amplifiers (to allow playback from magnetic tape to oscillograms), and (g) Fluke model 8200 A digital voltmeter and Techtronics type 422 oscilloscope for periodic data checks during testing. Figure 12 shows equipment setup at the recording station.

Test Procedures

26. The tests were conducted on 21-22 September 1982 in the following sequence:

- a. Series A; center sluice discharge.
- b. Series B; center sluice and spillway discharge.
- c. Series C; discharge all sluices.
- d. Series D; discharge all sluices and spillway.
- e. Series E; emergency gate lowered with center sluice discharge.

Individual tests were recorded on magnetic tape for 4 min. A portion of the taped data was transferred to oscillograms to confirm that the data were being recorded properly and to make a visual check and some initial computations of results.

27. The procedure was generally the same for test Series A, B, C, and

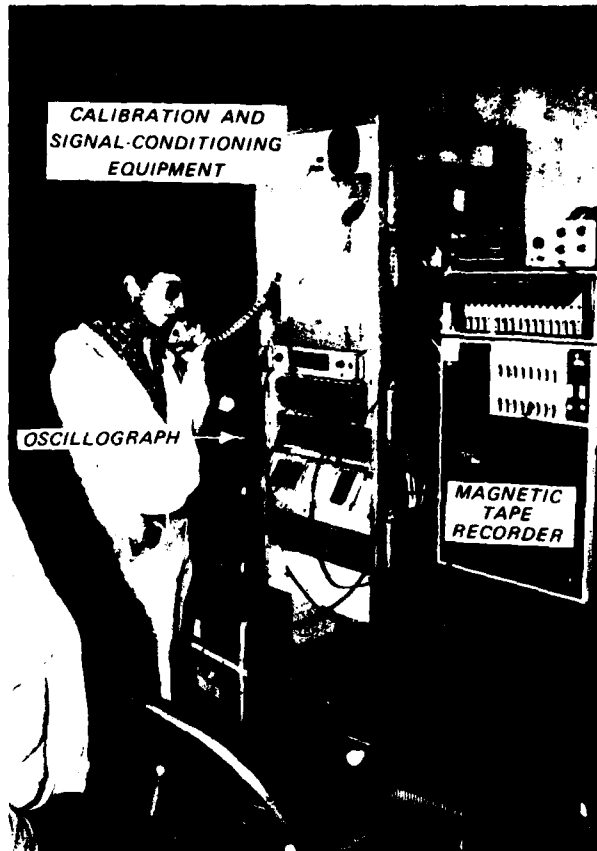

Figure 12. Recording station and equipment

D (Series E performed at one gate opening only) and consisted of the following:

- a. Record test number, gate opening, date, time, and conditions.
- b. Record step calibrations.
- c. Record zero levels.
- d. Raise test gate to desired opening; allow flow to stabilize.
- e. Record data on tape and oscillograms.
- f. Record discharge, pool elevations, and air and water temperatures.
- g. Repeat steps a, c-f for each gate opening.
- h. Record posttest step calibration.

28. Voice comments on the tape and notes on the oscillograms were continuously made for later reference. Gain changes and calibrations were made as required during the test period.

PART III: TEST RESULTS AND ANALYSIS

29. All data channels were recorded and reduced simultaneously providing a direct time-dependent relationship among all channels. All data reduction was conducted at WES. To reduce the data, each recorded 4-min test was visually scanned and a representative 1-min sample of each data channel digitized. These data were then digitally filtered to obtain the optimum sampling rate and time span (40 sec) for the data analysis of each parameter measured.

Air Discharge

30. Pitot tube differential pressures were measured at the locations shown in Plate 1 for determining the air discharge in the air vents feeding the center (LV1-2) and right (RV1-2 and RV3-6) sluices. Differential pressures from transducers LV1, RV1, and RV3-5 were used to compute airflow into the sluices (upstream direction). Transducers LV2, RV2, and RV6 recorded pressure differentials relating to reverse airflow (downstream direction).

31. Velocity at a point V_p is proportional to the recorded differential pressure when measured by a pitot tube (Rouse 1962). This relation is given by the equation

$$V_p = K \sqrt{\Delta p} \quad (1)$$

where

K = constant of proportionality

Δp = differential pressure between points A and B (Figure 13).

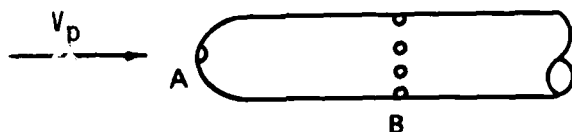

Figure 13. Pitot tube tip

The pitot tubes used in the Libby tests were calibrated by the National Space Technology Laboratories (NSTL), Bay St. Louis, Miss. (Hart 1981). The calibrated value of K was determined to be 351.90. The Mach number for all point velocities measured was less than unity, the "worst-case" average value being

0.23. For engineering calculations the effects of compressibility may be safely neglected if the Mach number is less than 0.30 (Vennard and Street 1975). Therefore the compressibility of air was not considered in the data analysis.

32. Each pitot tube support strut was located approximately 30 ft from the beginning of the splitter plate section. This corresponds to strut locations of 9.1 equivalent diameters ($D_e = 3.29$ ft) for the right and left vents leading to the center sluice and 6.2 equivalent diameters ($D_e = 4.87$ ft) for the right sluice air vent. Point velocities were measured at the vertical locations in the air vents shown in Plate 2.

33. In all vents, the velocity distribution was assumed to be essentially uniform from wall to wall. This assumption is considered adequate due to (a) the short distance from the vent entrances to the measurement locations, (b) the high Reynolds number (R) computed for each test indicating turbulent flow, and (c) the fact that the measured data at three vertical points in the right sluice air vent were essentially equal. Therefore the velocity for the right sluice air vent was assumed to be the average of the three measurements (RV3, 4, 5) while the velocities for the center sluice air vents were assumed to be the measured values of the single pitot tubes, LV1 and RV1. The degree of validity of this assumption can be demonstrated with the standard deviation of the cross-sectional point velocities measured in the right sluice vents, i.e. RV3, RV4, and RV5. The standard deviation, on the average, was 5.8 percent of the mean implying that the assumption of uniform velocity distribution at the strut is reasonable. The velocities were multiplied by the cross-sectional area of the respective air vents (shown in Plate 2) to determine the discharge.

34. As stated earlier, the test program was divided into four major test series, i.e., Series A, B, C, and D, with each being conducted under different flow conditions (explained in paragraph 26). Measured point velocities for each test series are given in Tables 2, 3, 4, and 5 with the corresponding discharges presented in Table 6.

Air vents

35. All pertinent airflow data channels (those shown in Plate 1) responded very similarly providing excellent correlation between measurement locations. This is evident in the typical airflow and pressure time-histories given in Plate 6. Therefore the total airflow feeding the center sluice through the air vents at any given point in time was computed to be the sum of

the right vent discharge (RV1) and the left vent discharge (LV1). A typical example showing that the right and left vents feed the center sluice essentially equal quantities is shown by the plot of average airflow versus gate opening in Figure 14.

36. As shown by Plate 7, the center sluice airflow curves for all test series follow the same general shape. In each series, the highest average airflow occurred at a gate opening of 9 ft, or 53 percent of full gate opening. Other maximums also occurred at gate openings of 7 ft during Series C and 15 ft during Series A and C. The lowest average airflow occurred at the 1-ft gate opening in all cases. The data indicate that airflow through the center vent system varies somewhat depending on whether the center sluice is operating alone or in combination with the outboard sluices. There was no recorded reversal of airflow in the center sluice air vent system. Although there was a continuous signal from transducers RV2 and LV2, it was due to air flowing in the direction opposite of that shown in Figure 13.

37. Plate 8 gives the airflow curves for the right sluice during uniform center and right sluice service gate operation. Airflow differed considerably from Series C to Series D at gate openings greater than 50 percent. The maximum average airflow for Series C occurred at the 7-ft gate opening, while the maximum for Series D occurred at the 11-ft gate opening. Also, at the higher gate openings the airflow tended to increase with gate position during Series D, whereas the airflow tended to decrease with gate opening during Series C. This is partly due to hindrance of the exit portal ventilation during spillway flow (explained in detail in paragraph 40). Also shown in Plate 8 is the right sluice airflow curve determined by an earlier test conducted by WES (Hart 1981). This earlier test is most closely comparable to Series C tests. As is readily seen, the discharges in the earlier test were significantly less than those measured in Series C. This is due in part to the considerable streamlining of the exit portal of the right vent (Figure 6). The premodified air vent was connected to the right sluice chamber by a constricting 90-deg miter bend at the top of the gate chamber (Figure 15). The bend was streamlined by modifying its geometry as shown in Figure 15. This provides a larger, smoother, more efficient transition from the air vent to the sluice chamber. In addition to the air vent modification, two other differences in test conditions are cited as possible contributors to the differences in discharges. First, the method of data acquisition employed in the

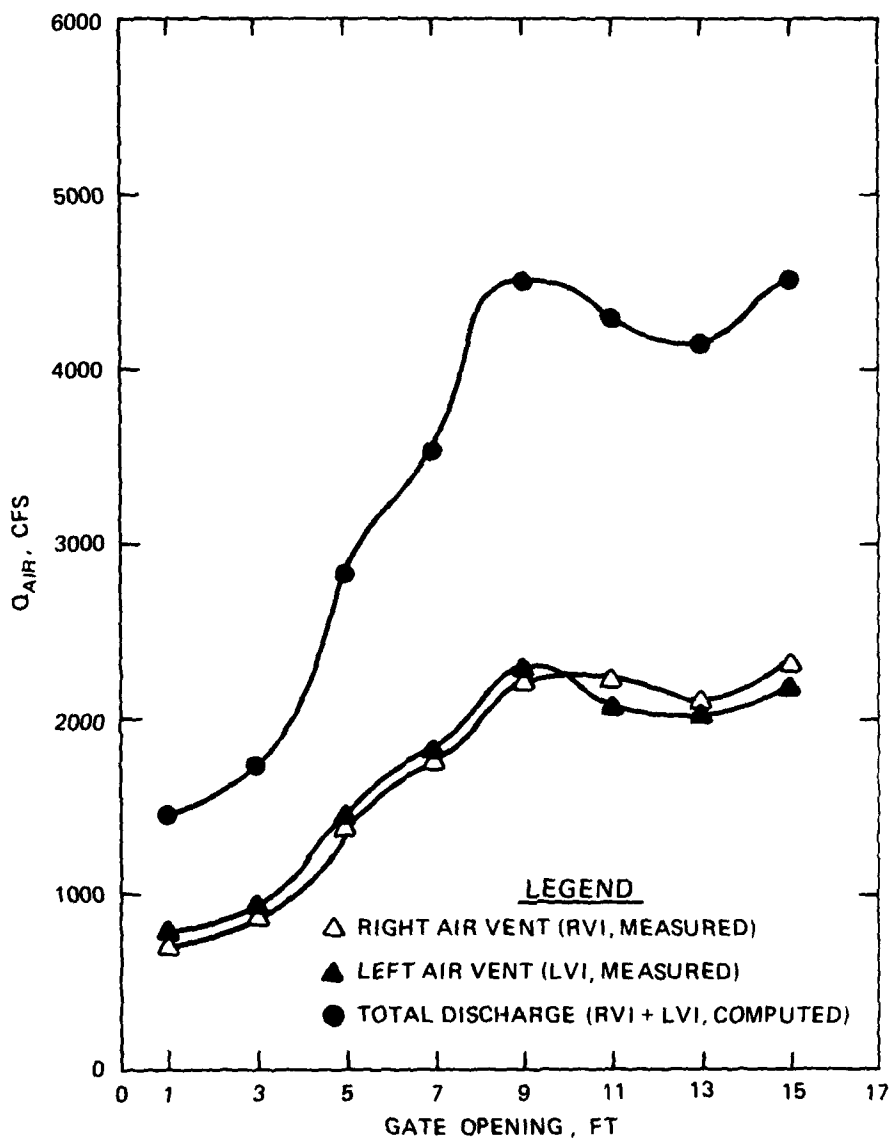

Figure 14. Average airflow versus gate opening, Series A, center sluice

earlier tests, i.e., data read from a digital multimeter along with very short time-histories being recorded on an oscillograph chart, were not adequate to accurately record the complex airflow conditions that existed. Second, the earlier data were measured with only the right sluice operating while the present data were measured with all three sluices open.

38. At high gate openings during Series D (with spillway flow), sluice gate operation was altered in order to maintain the established tailwater criteria. Instead of operating all sluice gates uniformly, the outboard sluices were operated at lower gate openings than the center sluice. The respective gate positions in each sluice during the affected tests are given below.

Test	Gate Opening, ft	
	Center Sluice	Outboard Sluices
1	15	12
2	16	11

The airflows in the right vent during Tests 1 and 2 were considerably less than the corresponding airflows during uniform gate operations. This is shown in Figure 16. These results suggest that unequal gate operation may cause the airflow to be different from that existing with uniform gate operation.

39. There was no reverse airflow in the right sluice vent during right sluice operation (Series C and D). However, the tests indicated that reverse airflow existed in the air vent feeding the right sluice during Series A in which the right sluice was not operating. These flows, given in Table 6, ranged from no detectable airflow at the 7-ft center sluice gate opening to a maximum airflow of 1,171 cfs at the 3-ft gate opening. This air is being drawn back through the lower vent because of the low pressures created by the high velocity airflow in the entrance portal of the upper vent in the vicinity of the splitter plate (Figure 17).

40. An overall increase of air discharge through the vents was observed for tests conducted with combined sluice and spillway flow, i.e. Series B and D. Because of the outlet works configuration (Figure 3), spillway discharge is directed over the sluice exit portals. This hinders ventilation through the exit portals and causes more air to be drawn through the air vent system. Therefore the actual quantity of air required by the flow, or air demand, is not necessarily higher during combined sluice and spillway flow, as the air flow curves of Plates 7 and 8 indicate; rather, for the stated reason, the airflow is simply higher through the air vent system. However, values given for

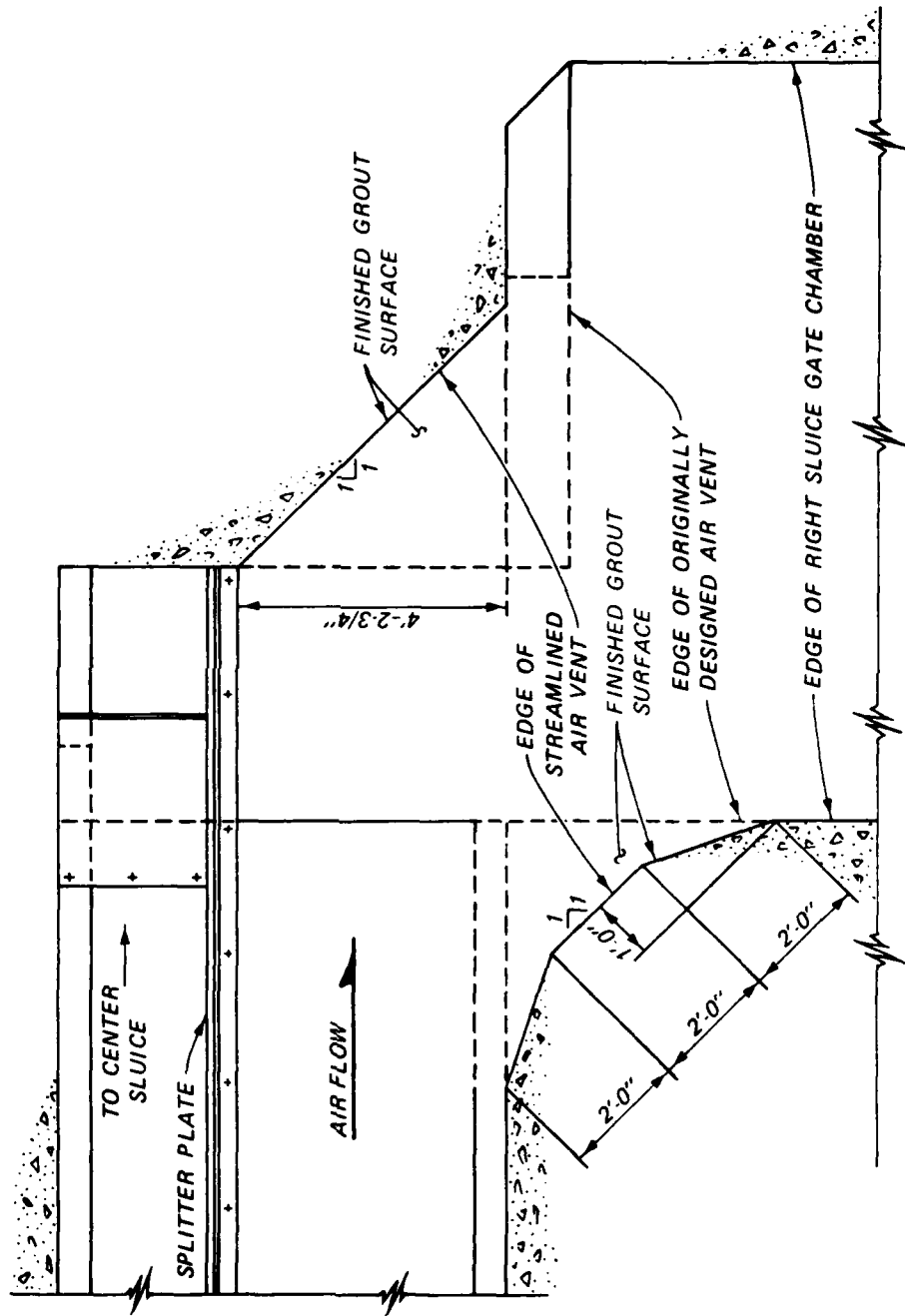

Figure 15. Right sluice air vent-to-chamber transition

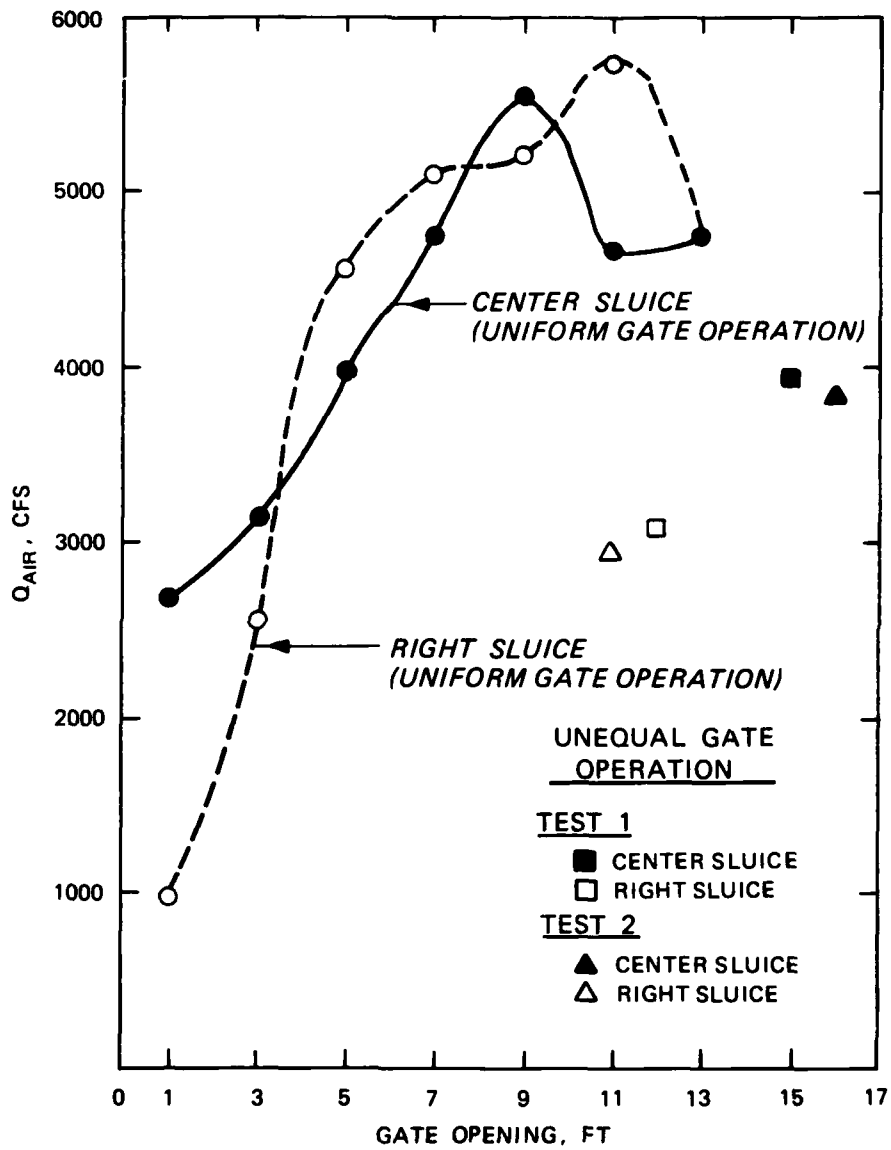
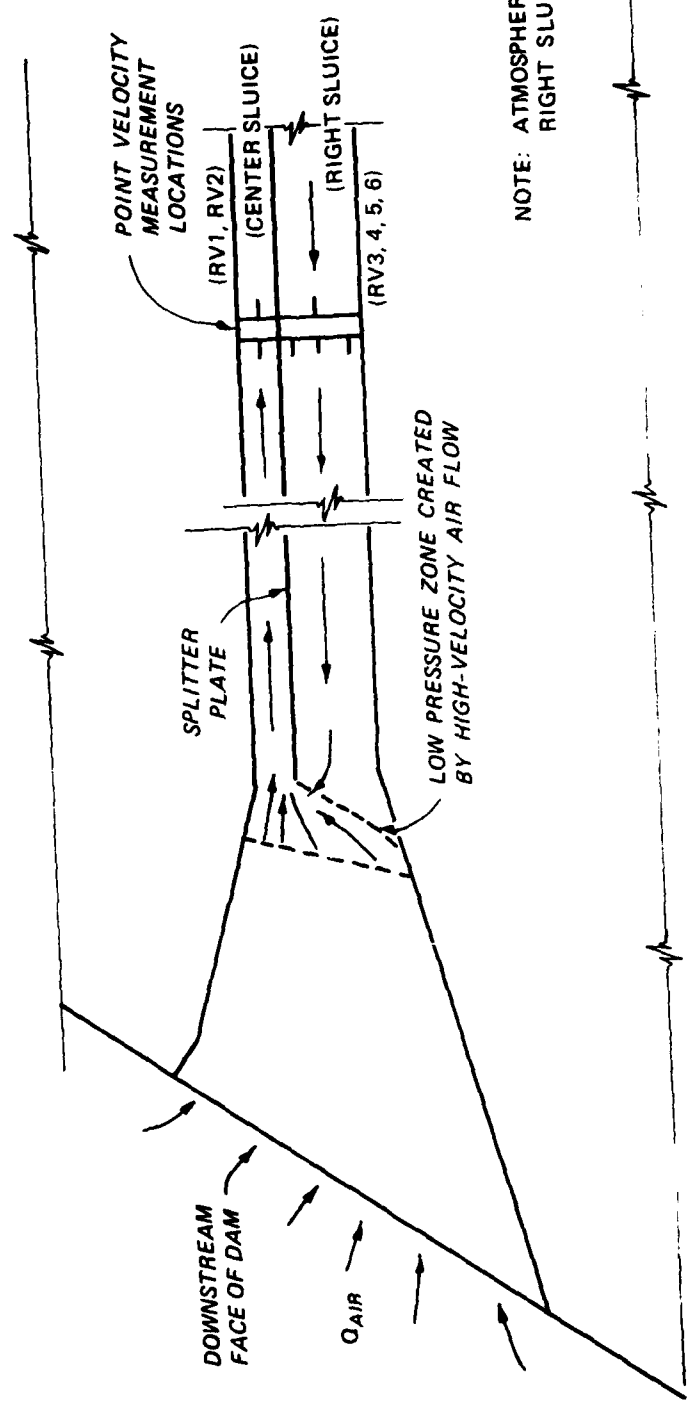

Figure 16. Average airflow versus gate opening, Series D



NOTE: ATMOSPHERIC PRESSURE AT
RIGHT SLUICE EXIT PORTAL

Figure 17. Reverse airflow in right sluice air vent, Series C

Tests B and D do more closely indicate the total air demand of the sluice.

41. As the time-histories of Plate 6 show, unsteady airflow existed in each air vent with the flow oscillating in a pseudosinusoidal fashion. This gusting is described by recorded maximum and minimum values fluctuating about the average airflow at a certain frequency (Table 6). The gusting frequencies were determined by transforming the data from the time domain to the frequency domain with a mathematical Fourier Transform (or Fast Fourier Transform (FFT)). On the average, gusts ranged from ± 25 percent of mean flow at a gusting frequency (f_G) of 0.4 cps with no frequencies greater than 1.0 cps. Figure 18 is an example time-history plot and its equivalent FFT plot which gives the dominant gusting frequency. The highest values for each test series are shown by the following condensed tabulation:

<u>Series</u>	<u>Test No.</u>	<u>Gate Opening, ft</u>	<u>Air Discharge, cfs</u>			<u>f_G cps</u>
			<u>Max</u>	<u>Mean</u>	<u>Min</u>	
<u>Center Sluice</u>						
A	6	9	5,822	4,505	3,123	0.2
B	4	9	6,470	5,412	4,427	0.2
C	4	7	5,378	3,999	3,260	0.4
C	5	9	5,523	3,964	2,830	0.3
D	5	9	6,867	5,565	4,200	0.2
<u>Right Sluice</u>						
C	4	7	5,833	4,441	3,299	0.3
D	4	11	6,674	5,747	5,023	0.5

Plates 9-11 show the maximums and minimums at each gate opening along with their respective gusting frequencies. It should be noted that this gusting was also observed by Hart in the premodification airflow tests. However, due to the method of data acquisition employed, it was not possible to analyze.

42. Kalinski and Robertson (1943) found the ratio of the air demand to water discharge (β) to be a function of the Froude number minus one in a conduit operating under hydraulic jump conditions. The Corps of Engineers combined this information with field measurements and derived a suggested design curve. The Libby air vent discharges from Table 6 have been plotted on the Hydraulic Design Criteria (HDC) chart reproduced in Plate 12. The Froude number (F) for the data was computed by

$$F = V/\sqrt{gy} \quad (2)$$

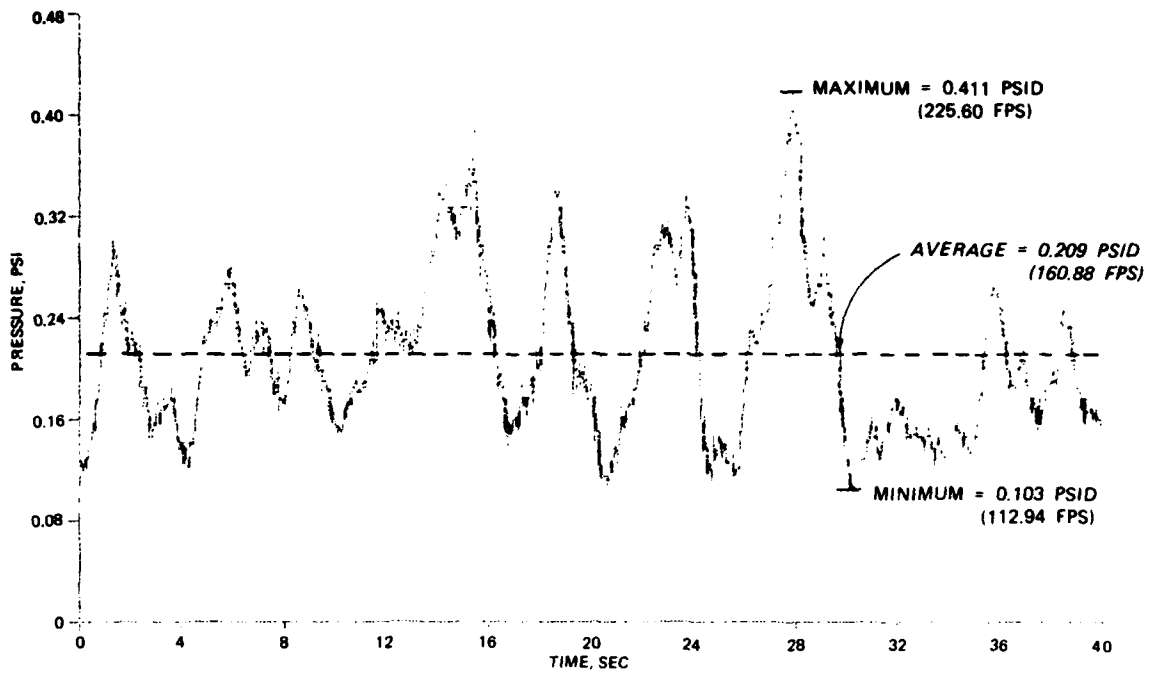

a. Time-history plot

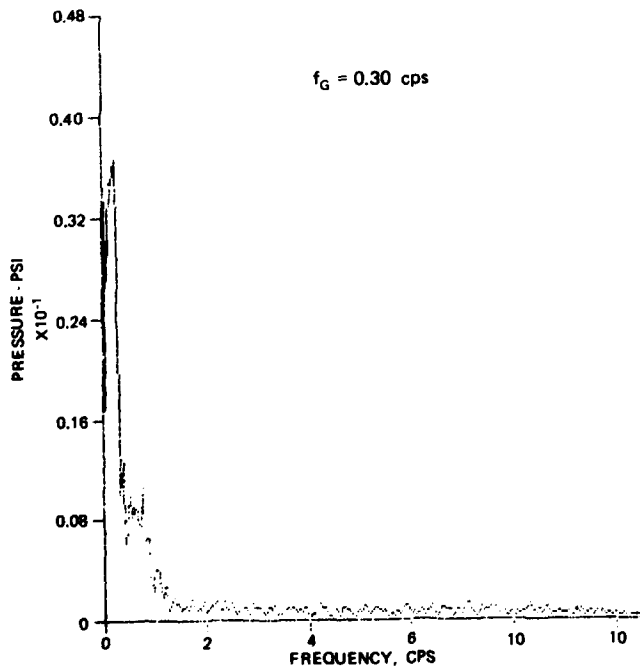

b. FFT plot

Figure 18. Example of 40-sec digital time-history and FFT plot (Series C, Test 5, 9-ft gate opening, transducer LV1)

where

V = water velocity at the vena contracta, fps

g = gravitational acceleration, ft/sec²

y = water depth at the vena contracta, ft

More recently, however, it has been shown that a different set of curves may exist for free flow and spray conditions, as at Libby Dam. Data presented by Sharma (1976) indicate that the air requirements for free flow, i.e. gate-controlled flow with free water surface and no hydraulic jump, and spray conditions may be three and six times, respectively, that for the hydraulic jump condition. The curves presented by Sharma plot β against F rather than $F - 1$ and are well suited for conduit discharge not influenced by tailwater conditions or when a hydraulic jump does not form in the conduit. These curves, along with the Libby air vent discharges, are presented in Plate 13. At the small gate openings, a very high air-water discharge ratio (Q_a/Q_w), occurs (Plate 14). At these small gate openings spray flow was observed. The jet issuing beneath the gate sprays out into numerous small droplets entraining a relatively large quantity of air.

Aerator

43. Pressures were measured in the center sluice aerator at the locations shown in Plates 1 and 3. The data are presented by test series and listed in Tables 7-10. As seen by the time-histories in Plate 6, the pressures responded in phase with the air velocity measurements. Aerator pressures are described by maximum and minimum negative pressures oscillating about a mean and correspond to the maximum and minimum discharges shown in Table 6. The gusting frequencies (f_G) given in Table 6 also represent aerator pressure fluctuations.

44. At no time was airflow into the slot restricted by the impingement of water flow upon the slot. Airflows were controlled by the low pressure region downstream of the slot created by the deflector. The lowest pressures acting in the slot occurred at transducer locations AR4 and AR5, downstream and center-line floor locations, respectively. The pressures recorded at the wall locations (AR1, AR2, and AR3) were approximately equal during each test indicating uniform airflow at this cross section in the slot. Also, transducer AR6 showed pressures of the same magnitude as those at the slot wall locations.

45. The data suggest that the air discharge is in part governed by the

pressures acting in and just downstream of the aerator slot. Plate 15 is a plot of the maximum, minimum, and mean pressures acting on the downstream portion of the aerator slot (AR4) against the measured airflow and shows a definite relationship between the two. Plate 16 gives the values of airflow and pressure at each gate opening to show their relationship.

Differential Pressures

46. The pressure drop from the atmosphere to the aerator was measured in the right and center sluices at the locations shown in Plate 1 by transducers GCR and GCC, respectively. The maximum, average, and minimum differential pressures corresponding to the maximum, average, and minimum air velocities are listed in Tables 2-5. The air vent gusting frequencies given in Table 6 also apply to the differential pressures. Corps criteria (OCE 1980) suggest that the maximum air vent velocity not exceed 150 fps and that the head loss through the vents not exceed 0.5 to 1.0 ft of water. The maximum recorded differential pressure in the right sluice chamber was 0.65 ft of water (GCR, Series D, Test 4) and 4.04 ft of water for the center sluice vents (GCC, Series B, Test 3). The maximum recorded air vent point velocity was 291 fps in the right sluice air vent (RV3, 4, and 5, Series D, Test 4) and 267 fps in the center sluice vent (RV1, Series B, Test 3). The large difference between the differential pressure in the right and center sluices for approximately the same velocities is because of the smaller cross-sectional area and the additional length, bends, and abrupt enlargements in the center sluice vent system (Figure 3 and Plate 1). A typical time-history plot of differential pressure is shown in Plate 6.

Lower Service Gallery Wall Pressures

47. An absolute pressure transducer, CSC, was located in the center sluice gate chamber to measure the pressures acting on the modified wall separating the gate chamber from the service gallery. The maximum, average, and minimum pressures are listed in Tables 2-5 with gusting frequencies as shown in Table 6. A typical time-history is given in Plate 6. This new wall was designed to withstand pressures of -2.0 psi. The pressures recorded never reached the design value but did approach it at times. The maximum values for each test series are listed in the following condensed tabulation:

Series	Test No.	Gate Opening, ft	Pressure, psi		
			Maximum	Average	Minimum
A	6	9	-1.30	-0.77	-0.31
B	3	11	-1.39	-0.86	-0.52
C	7	13	-1.00	-0.39	-0.11
D	5	9	-1.50	-0.95	-0.48

Sluice Invert Pressures

48. Sluice invert pressures were measured during all tests in the center sluice at the locations shown in Plate 4. These locations are identical with those used in tests conducted prior to installation of the aerator (Hart and Tool 1976). The highest, lowest, and mean pressures were determined from the digitized data time-histories along with the maximum instantaneous peak-to-peak pressure fluctuation for each test. These pressures are listed according to test series in Tables 11-14.

49. A primary objective of these tests was to determine the effectiveness of the aerator in reducing the negative pressures acting on the sluice inverts which caused the cavitation damage experienced in the early operation of Libby Dam. Plate 17 shows the pressures acting on the invert at the gate openings which created the most severe conditions prior to the installation of the aerator. In contrast, Plates 18 and 19 show the pressures existing at these same gate positions with the aerator in operation. As shown by these graphics, the adverse pressure conditions have virtually been eliminated. The following tabulation lists the comparative data given in Plates 17 (without aerator) and 18 (with aerator, Series A).

Gate Opening	Transducer Station	Sluice Pressures, Feet of Water							
		Instantaneous						Dynamic (pk-pk)	
		Maximum		Minimum		Mean		Pre	Post
		Pre	Post	Pre	Post	Pre	Post		
1	SL 1	20	0.4	-25	-3.2	-3	-1.8	31	3.1
	SL 2	4	1.1	-9	-5.3	-4	-1.9	15	5.7
	SL 3	20	4.0	-13	-1.8	0	1.2	33	3.9
	SL 4	0	0.0	-31	-4.8	-18	-1.3	31	4.8
	SL 5	0	1.6	-30	-5.2	-18	-1.5	30	4.2
5	SL 1	6	0.8	-13	-2.7	-5	-0.8	15	2.9
	SL 2	9	0.0	-22	14.9	-8	6.9	32	13.6
	SL 3	32	13.5	-30	1.8	-7	8.0	50	8.7
	SL 4	23	5.6	-24	-7.0	-5	-1.1	45	11.0
	SL 5	20	15.7	-25	1.6	-10	9.4	41	8.5

(Continued)

		Sluice Pressures, Feet of Water							
Gate Opening	Transducer Station	Instantaneous				Mean		Dynamic (pk-pk)	
		Maximum		Minimum		Pre	Post	Pre	Post
		Pre	Post	Pre	Post				
9	SL1	5	-5.4	-13	-10.0	-4	-6.8	16	3.8
	SL2	2	6.1	-15	-6.6	-6	-1.0	17	11.4
	SL3	-6	10.1	-26	0.6	-14	5.6	20	8.7
	SL4	5	-0.3	-11	-13.5	-1	-6.8	14	12.0
	SL5	-1	--	-15	--	-7	--	14	--

-- Data indeterminate.

50. In the preaerator tests, each transducer recorded negative mean pressures at all gate openings. However, the postaerator mean pressures vary randomly from positive to negative from transducer to transducer. The pressures have been raised to such an extent that some mean values now register positive. The random variation of the mean pressures that occurs for the same gate opening may be due to the actual shape of the sluice invert. The invert construction did not conform to the designed parabolic shape; rather it tends to follow a series of chords between construction joints along the theoretical surface (Hart and Tool 1976). The differing slopes between the construction joints and the location of the transducers with respect to these construction joints may cause the flow to act in such a way as to cause the mean pressure for each transducer to be either positive or slightly negative. Hart's report presents a detailed description of the invert profile. The mean pressures acting on transducer SL1, located approximately 18 ft downstream of the aerator, were negative during all tests and seemed to be directly influenced by the action of the aerator pressures. Plate 20 presents typical time-histories of the aerator transducers and the sluice invert transducers SL1 and SL2. The pressure data shown in Tables 11-14 for invert pressure transducer SL5 vary significantly depending on whether the center sluice is operating alone (Series A) or in combination with the outboard sluices (Series C and D). The data shown have been verified as being correct as recorded during the tests and the difference is not explainable.

51. The cavitation indices listed in Tables 11-14 were calculated using the equation

$$K_i = \frac{h_i - h_v}{v_i^2 / 2g} \quad (3)$$

where

$$\begin{aligned}K_i &= \text{cavitation index at transducer } i \\h_i &= \text{mean absolute pressure at transducer } i, \text{ ft} \\h_v &= \text{vapor pressure, ft (estimated to be -30.7 ft)} \\(\bar{V}_i^2/2g) &= \text{velocity head at transducer } i, \text{ ft}\end{aligned}$$

The average velocity \bar{V}_i was determined from the continuity equation $\bar{V} = Q/A$, having calculated depth by the step method (Henderson 1966). Although there is no incipient cavitation index for reference, the calculated indices are assumed to be greater than incipient since all pressures were well above vapor pressure. Tables 11-14 indicate that the indices generally decrease with gate opening. Since the pressures did not generally decrease with gate opening the downward trend is attributed to an increasing velocity head with gate opening. The indices are greater than those determined for the preaerator condition. This shows the pressures moving farther away from cavitation with the introduction of the aerator. Because of the relative accuracy of the discharges, and the water depth and velocity calculations, the quantitative indices are presented as relative rather than absolute indicators.

Vibration of Structure

52. Vibrations were measured at el 2240.25 on the lower service gallery floor directly above the center sluice as shown in Plate 1. The vibrations were insignificant in all tests. Accelerations were highest at gate openings between 7 and 11 ft with the frequencies associated with these accelerations being higher than for other gate openings and very rapidly damped. Frequencies were considerably lower at a gate opening of 5 ft or less. Tables 15-18 list the greatest instantaneous maximum (+), minimum (-), and peak-to-peak accelerations along with the predominant frequency of fluctuation and displacement. A sample time-history with its corresponding FFT plot for each measured direction is shown in Plate 21. The sinusoidal displacements were estimated by the equation

$$d = \frac{32.2 (\text{acceleration})}{(2\pi \text{ freq})^2} \quad (4)$$

where

d = peak-to-peak sinusoidal displacement, ft
acceleration = greatest peak-to-peak acceleration, g's
freq = predominant frequency, cps

Emergency Gate Test

53. On 22 September 1982, a test was conducted (Series E) lowering the project's sluice emergency gate, weighing approximately 23 tons, under flow conditions into the center sluice. The closure was not successful. The attempted closure was conducted with a center sluice service gate opening of 11 ft (approximately 9,400 cfs). A cluster of three accelerometers located on an interior beam of the emergency gate (Plate 5) measured accelerations of the gate throughout the gate lowering procedure while all other data channels were also being monitored. This section presents the recorded data and describes the procedures and observations made during the test. The data are listed in Table 19 with time-histories presented in Plate 22-24.

54. Emergency gate lowering was uneventful until the paint marks on the gate cable indicated approximately 2-ft gate opening. At this time, estimated to be about 15 min after the lowering commenced, action in the gate slot became very violent and the lifting cables began a swaying (2 to 3 ft) and bouncing motion that caused the slack cable limit switch to trip and shut down the gantry crane. During this time, a span of about 12 sec, the data showed a drastic increase in magnitude. For reference, this time is referred to as the "during" period. This "during" period shows an increase in air discharge of approximately 50 percent to 8,233 cfs, which corresponds to velocities in excess of 350 fps in each center sluice air vent, while the pressure drop through the air vent system approximately doubled. Also, pressures in the aerator slot were generally 50 to 100 percent lower and minimum pressures on the sluice invert were 40 percent lower. However, these values do not indicate the actual maximum discharge or pressures experienced because the pressures at some transducers greatly exceeded the transducer range, as shown by the time-histories of Plate 22. Pressures acting on the lower service gallery wall at the center sluice chamber also exceeded the transducer range (CSC) and may have exceeded the wall design pressure (-2 psi). In addition, peak-to-peak accelerations on the lower service gallery floor almost tripled (Plate 23). Emergency gate

peak-to-peak accelerations increased from less than 0.5, 0.2, and 0.1 g's to 6.1, 3.6, and 3.7 g's in the vertical, longitudinal, and transverse directions, respectively, with the transducer range exceeded in the vertical direction only (Plate 23). These high values ended abruptly approximately 12 sec after they began. Conditions during this "after" period were equivalent to those experienced at gate openings of 1 ft. Emergency gate accelerations decreased to maximum peak-to-peaks of 1.8, 1.6, and 0.6 g's in the vertical, longitudinal, and transverse directions, respectively. Thirteen seconds after the recorded violence ended, the instrumentation cables of the emergency gate accelerometers were severed by the gate lifting beam as it became detached from the gate during this sequence of events (the exact time is not known). At no time did the gate completely seal. A flow estimated at about 500 cfs continued to be observed through the sluice indicating a gate opening estimated to be about 8 in. The following is a timetable of events as observed by involved personnel.

	Time (Hours)	
Before	1430	Service gate opened to 11 ft.
	1449	Emergency gate lowered into center sluice. Data recording begun.
During	1457:14	Emergency gate lowering uneventful. All data channels registering values corresponding to an 11-ft gate opening.
	1457:14	Action in gate slot very violent. Magnitude of values on most data channels increased dramatically.
After	1457:30	Cable slack limit switch tripped and gantry crane shut down.
	1457:30	Recorded data shows abrupt decrease in magnitude of data. Data now equivalent to that of 1-ft gate opening.
After	1458	Emergency gate accelerometer cables severed by gate lifting beam.
	1510	Data recording terminated. No change in data from 1457:30.

55. The emergency gate was later retrieved by slowly regaining flow

control with the service gate (being careful to avoid a gate catapult condition) and then reattaching the lifting beam to the gate. An underwater inspection made by a remote-controlled submersible camera (DART) revealed no visible damage to the area of the sluice entrance or gate slot. However, damage had occurred to the gate seals, primarily near the corners of the top seal.

PART IV: CONCLUSIONS

56. The following conclusions and determinations result from literature review, field observations, and analysis of the reduced Libby Dam prototype data.

57. Air discharge:

- a. Air vent discharge in the center sluice vent system reached a maximum at a 9-ft sluice gate opening (53 percent of full) and reached a minimum at the 1-ft gate opening under all flow conditions. Maximum discharge in the right sluice vent occurred at 7- and 11-ft gate openings during conditions with and without spillway flow, respectively.
- b. High air-water discharge ratios exist during spray conditions, i.e., gate openings up to about 5 ft.
- c. Airflow increased through the air vents during combined spillway-sluice flow due to the resulting hindrance of ventilation through the exit portal.
- d. Unequal service gate operation may cause different airflow than uniform gate operation.
- e. Gusting was experienced at all gate openings and ranged, on the average, ± 25 percent of mean flow at a gusting frequency of approximately 0.4 cps.
- f. There was no recorded reversal of airflow in the vents during their operation. However, reverse airflow did exist in the right sluice air vent during tests in which the right sluice was not operating and there was no spillway flow to cover the sluice exit portal.

58. Aerator:

- a. At no time was airflow into the slot restricted by the impingement of water flow upon the slot.
- b. Air discharge is in part governed by the low pressures created by the deflector in and just downstream of the aerator slot.

59. Differential and lower service gallery wall pressures:

- a. Except for the head loss through the right sluice vent, the maximum recorded air vent velocities and head losses exceed the limits suggested in EM-1110-2-1602 (OCE 1980). Maximum velocities of 291 and 267 fps in the right and center sluice vents, respectively, were measured along with a maximum head loss of 4.04 ft of water in the center sluice vent system.
- b. The recorded pressures acting on the service gallery wall were less than the design value of -2 psi.

60. Sluice invert pressures:

- a. Cavitation-inducing negative pressures on the center sluice invert have been virtually eliminated with the introduction of the aerator. All calculated cavitation indices are assumed to be greater than incipient since all pressures used in the calculations were well above vapor pressure. The cavitation index generally decreased with increasing gate opening primarily due to increasing velocity.
- b. The overall pressures have been raised to the extent that some mean pressures are now positive whereas the preaerator pressures were all negative.

61. Vibrations:

- a. The vibrations computed from measured accelerations on the gallery floor were generally insignificant.

62. Emergency gate closure test:

- a. The sluice emergency gate failed to close under flow during the controlled test.
- b. Emergency gate placement under flow significantly affected the measured parameters in comparison with the extremes that occurred during normal sluice operation. During the placement:
 - (1) Maximum air vent velocities increased by more than 50 percent (pressure transducer range exceeded).
 - (2) Pressure drop through the air vent system approximately doubled (transducer range exceeded).
 - (3) Pressures in the aerator slot were generally 50 to 100 percent lower (transducer range exceeded).
 - (4) Minimum pressures on the sluice invert were 40 percent lower.
 - (5) Pressures acting on the lower service gallery wall at the center sluice chamber exceeded the range of the pressure transducer and may have exceeded the design pressure (-2 psi).
 - (6) Peak-peak accelerations on the lower service gallery floor almost tripled (transducer range exceeded).

REFERENCES

- Dortch, M. S. 1976 (Dec). "Center Sluice Investigation, Libby Dam, Kootenai River, Montana; Hydraulic Model Investigation," Technical Report H-76-21, U. S. Army Engineer Waterways Experiment Station, CE, Vicksburg, Miss.
- Hart, E. D. 1981 (Dec). "Air Demand Tests, Libby Dam, Kootenai River, Montana," Miscellaneous Paper HL-81-6, U. S. Army Engineer Waterways Experiment Station, CE, Vicksburg, Miss.
- Hart, E. D., and Tool, A. R. 1976 (Oct). "Sluice Pressures, Gate Vibrations and Stilling Basin Wall Pressures, Libby Dam, Kootenai River, Montana," Technical Report H-76-17, U. S. Army Engineer Waterways Experiment Station, CE, Vicksburg, Miss.
- Henderson, F. M. 1966. Open Channel Flow, Macmillan, New York.
- Kalinske, A. A., and Robertson, J. M. 1943. "Entrainment of Air in Flowing Water--Closed Conduit Flow," Transactions, American Society of Civil Engineers, Vol 108.
- Office, Chief of Engineers. 1980. "Engineering and Design: Hydraulic Design of Reservoir Outlet Works," EM 1110-2-1602, Washington, D. C.
- Rouse, H. 1962. Elementary Mechanics of Fluids, Wiley, New York.
- Sharma, H. R. 1976 (Nov). "Air Entrainment in High Head Gated Conduits," Journal, Hydraulics Division, American Society of Civil Engineers, Vol 102, No. HY11, Proc Paper 12523, pp 1629-1646.
- U. S. Army, Corps of Engineers, "Hydraulic Design Criteria," prepared for Office, Chief of Engineers, by U. S. Army Engineer Waterways Experiment Station, CE, Vicksburg, Miss., issued serially since 1952.
- Vennard, J. K., and Street, R. L. 1975. Elementary Fluid Mechanics, Wiley, New York.

Table 1
Instrumentation

Code	Instrument		Range	Instrument Location*		Cable Length, ft	Parameter
	Type	Description		Sta**	El		
SGAV	Sundstrand (QA-116-17, QA-1000)	Service gallery floor	0.01-g to 50-g	--	2240.25	350	Structure acceleration --vertical
SGAL	Sundstrand (QA-116-17, QA-1000)	Service gallery floor	0.01-g to 50-g	--	2240.25	350	Structure acceleration --longitudinal
SGAT	Sundstrand (QA-116-17, QA-1000)	Service gallery floor	0.01-g to 50-g	--	2240.25	350	Structure acceleration --tangential
RV1	Validyne DP9	Air vent strut	±0.5 psid	0+85.7	2279.4	400	Point velocity
RV2	Validyne DP9	Air vent strut	±0.5 psid	0+85.7	2279.4	400	Point velocity (reverse)
RV3	Validyne DP9	Air vent strut	±0.5 psid	0+85.7	2277.1	400	Point velocity
RV4	Validyne DP9	Air vent strut	±0.5 psid	0+85.7	2276.0	400	Point velocity
RV5	Validyne DP9	Air vent strut	±0.5 psid	0+85.7	2274.1	400	Point velocity
RV6	Validyne DP9	Air vent strut	±0.5 psid	0+85.7	2276.0	400	Point velocity (reverse)
LV1	Validyne DP9	Air vent strut	±0.5 psid	0+85.7	2279.6	400	Point velocity
LV2	Validyne DP9	Air vent strut	±0.5 psid	0+85.7	2279.4	400	Point velocity (reverse)
AR1	CEC 4-312	Aerator slot (wall, downstream)	±15 psia	0+63.5	2193.5	350	Absolute pressure
AR2	CEC 4-312	Aerator slot (wall, center line)	±15 psia	0+62.0	2194.0	400	Absolute pressure
AR3	CEC 4-312	Aerator slot (wall, upstream)	±15 psia	0+60.5	2195.0	400	Absolute pressure
AR4	CEC 4-312	Aerator slot (floor, downstream)	±15 psia	0+61.5	2189.2	400	Absolute pressure
AR5	CEC 4-312	Aerator slot (floor, center line)	±15 psia	0+60.0	2188.0	400	Absolute pressure
AR6	CEC 4-312	Aerator slot (floor, upstream)	±15 psia	0+58.5	2191.0	400	Absolute pressure
SL1	CEC 4-312	Center sluice invert	100 psia	0+78.4	2185.5	550	Sluice pressure
SL2	CEC 4-312	Center sluice invert	100 psia	1+21.2	2172.0	550	Sluice pressure
SL3	CEC 4-312	Center sluice invert	100 psia	1+49.5	2161.1	550	Sluice pressure

(Continued)

* See Plate 1.
** Scaled from drawings.

Table 1 (Concluded)

Code	Instrument		Instrument Location			Length, ft	Cable Parameter
	Type	Range	Description	Sta	EI		
SL4	CEC 4-312	100 psia	Center sluice invert	1+61.1	2156.3	550	Sluice pressure
SL5	CEC 4-312	100 psia	Center sluice invert	1+77.2	2149.0	550	Sluice pressure
GCR	Statham PM80TC	±0.5 psid	Right gate chamber handrail above aerator slot	0+64.0	2216.0	350	Differential pressure
GCC	CEC 4-312	±5 psid	Center gate chamber on floor above aerator slot	0+64.0	2214.0	420	Differential pressure
CSC	CEC 4-312	±15 psia	Center gate chamber handrail	0+50.0	2240.0	350	Absolute pressure
EGAV	Statham A69TC-5-350	±5 g's	Emergency gate	0+10.5	Varied	750	Gate acceleration --vertical
EGAL	Statham A69TC-5-350	±5 g's	Emergency gate	0+10.5	Varied	750	Gate acceleration --longitudinal
EGAT	Statham A69TC-5-350	±5 g's	Emergency gate	0+10.5	Varied	750	Gate acceleration --tangential

Table 2
Air Vent Point Velocities and Chamber Pressures
Series A

Test No.	Gate Opening ft	Item*	Center Sluice			Right Sluice			ΔP, Feet		P psi CSC
			RV1 fps	RV2	RV3	RV4	RV5	RV6	GCC	GCR	
1	1.0	Max	70.38	N.R.**	0.0	0.0	0.0	39.50	-0.22	Noise	-0.16
		Mean	58.04	1.46	1.66	1.66	0.0	0.0	-0.07		-0.09
		Min	50.92	1.21	1.29	1.29	0.0	0.0	0.0		-0.04
2	3.0	Max	78.69	1.06	1.16	1.16	0.0	0.0	-0.28		-0.15
		Mean	69.41	1.64	1.74	1.74	0.0	0.0	-0.21		-0.10
		Min	60.95	1.44	1.53	1.53	0.0	0.0	-0.15		-0.03
3	5.0	Max	134.58	1.27	1.39	1.39	0.0	0.0	†		-0.54
		Mean	114.03	2.80	3.02	3.02	0.0	0.0	--		-0.28
		Min	91.43	2.37	2.51	2.51	0.0	0.0	--		-0.13
5	7.0	Max	186.62	1.90	2.02	2.02	0.0	0.0	noise		-0.84
		Mean	143.37	3.88	4.12	4.12	0.0	0.0	-2.63		-0.46
		Min	105.94	2.98	3.12	3.12	0.0	0.0	-1.86		-0.33
6	9.0	Max	235.41	2.20	2.26	2.26	0.0	0.0	13.90		-1.30
		Mean	183.19	4.90	5.18	5.18	0.0	0.0	-2.65		-0.77
		Min	132.84	3.81	3.98	3.98	0.0	0.0	-1.73		-0.31
7	11.0	Max	225.33	2.76	2.81	2.81	0.0	0.0	27.35		-0.88
		Mean	184.20	4.69	4.33	4.33	0.0	0.0	-2.20	0.0	-0.55
		Min	135.15	3.83	3.60	3.60	0.0	0.0	-1.47		-0.14
8	13.0	Max	216.93	2.81	2.98	2.98	0.0	0.0	43.10		-0.82
		Mean	174.89	4.51	4.57	4.57	0.0	0.0	-2.17	0.0	-0.41
		Min	143.38	3.64	3.53	3.53	0.0	0.0	-1.62		-0.09
9	15.0	Max	237.37	4.94	4.81	4.81	0.0	0.0	46.29		-0.93
		Mean	192.10	4.00	3.81	3.81	0.0	0.0	-2.35	0.0	-0.49
		Min	163.17	3.39	3.26	3.26	0.0	0.0	-1.94		-0.28

* Max = highest recorded velocity, most negative P and ΔP; Mean = average velocity, average P and ΔP; Min = lowest recorded velocity, least negative P and ΔP.
 ** N.R. = No reverse flow detected.
 † -- = values not determinable from recorded data.

Table 3
Air Vent Point Velocities and Chamber Pressures
Series B

Test No.	Gate Opening ft	Item*	Center Sluice			Right Sluice						ΔP, Feet of Water		P psi CSC		
			RV1 fps	$\bar{Q} \times 10^6$	RV2	LV1 fps	RV3 fps	RV4 fps	RV5 Avg fps	$\bar{Q} \times 10^6$	RV6 fps	GCC	GCR			
8	1.0	Max	116.71	2.43	N.R.**	104.09	2.17	N.R.**	0.0	0.0	0.0	0.0	0.0	-1.69	noise	-0.27
		Mean	96.76	2.01		92.57	1.93							-1.58		-0.20
		Min	84.38	1.76		84.38	1.76							-1.46		-0.15
7	3.0	Max	146.16	3.04		125.65	2.61							-1.82		-0.35
		Mean	120.37	2.50		113.48	2.36							-1.65		-0.27
		Min	104.09	2.17		102.60	2.13							-1.51		-0.19
6	5.0	Max	202.92	4.22		191.94	3.99							-2.63		-0.80
		Mean	172.40	3.59		158.55	3.30							-2.24		-0.54
		Min	153.79	3.20		141.86	2.95							-1.97		-0.40
5	7.0	Max	248.83	5.18		235.41	4.90							-3.14		-1.12
		Mean	197.19	4.10		186.54	3.88							-2.65		-0.72
		Min	148.78	3.09		149.30	3.11							-2.05		-0.41
4	9.0	Max	266.84	5.55		271.16	5.64							-3.74		-1.34
		Mean	228.06	4.74		222.00	4.62							-3.07	0.0	-0.93
		Min	187.86	3.91		180.30	3.75							-2.42		-0.57
3	11.0	Max	266.84	5.55		262.46	5.46							-4.04		-1.39
		Mean	218.63	4.55		208.19	4.33							-2.84	0.0	-0.86
		Min	178.14	3.71		177.05	3.68							-1.85		-0.52
2	13.0	Max	238.51	4.96		225.33	4.69							-3.11		-0.91
		Mean	207.89	4.32		197.50	4.11							-2.63	0.0	-0.64
		Min	178.14	3.71		182.85	3.80							-2.29		-0.46
1	15.0	Max	227.38	4.73		211.14	4.39							-2.86		-0.77
		Mean	194.96	4.06		179.78	3.74							-2.47	0.0	-0.55
		Min	181.15	3.77		152.38	3.17							-2.20		-0.41

* Max = highest recorded velocity, most negative P and ΔP; Mean = average velocity, average P and ΔP; Min = lowest recorded velocity, least negative P and ΔP.
 ** N.R. = No reverse flow detected.

Table 4
Air Vent Point Velocities and Chamber Pressures
Series C

Test No.	Gate Opening ft.	Item	Center Sluice				Right Sluice				AP, Feet of Water		Psi GSC					
			RV1 fps	$\bar{Q} \times 10^6$	RV2 fps	LV1 fps	RV3 fps	RV4 fps	RV5 fps	Avg fps	$\bar{Q} \times 10^6$	RV6 fps		GCC	GCR			
1	1.0	Max	80.15	1.67	N.R.***	88.33	1.84	49.77	N.R.***	49.77	49.27	48.19	49.08	1.51	N.R.***	-0.30	-0.17	-0.20
		Mean	67.60	1.41		71.69	1.49	42.37		42.37	42.95	42.81	42.71	1.32		-0.15	--	-0.12
		Min	52.79	1.10		46.69	0.97	32.94		32.94	36.49	35.19	34.87	1.07		-0.03	--	-0.06
2	3.0	Max	99.53	2.07		92.84	1.93	85.20		86.34	89.37	86.97	2.68			-0.33	-0.05	-0.16
		Mean	89.92	1.87		82.38	1.71	76.21		76.94	77.82	76.99	2.37			-0.21	-0.03	-0.09
		Min	83.46	1.74		73.61	1.53	68.32		68.71	69.14	68.85	2.12			-0.12	-0.03	-0.03
3	5.0	Max	155.39	3.23		147.74	3.07	159.43		158.55	165.06	161.01	4.96			-0.86	-0.17	-0.43
		Mean	132.14	2.75		123.42	2.57	133.07		132.61	136.74	134.14	4.13			-0.51	-0.09	-0.21
		Min	120.37	2.50		108.46	2.26	103.50		107.66	108.98	106.72	3.29			-0.23	-0.04	-0.03
4	7.0	Max	229.14	4.77		218.06	4.54	250.38		243.80	268.00	254.06	7.83			-1.76	-0.47	-0.81
		Mean	170.95	3.56		161.64	3.36	191.13		189.50	199.69	193.44	5.96			-0.96	-0.21	-0.38
		Min	139.66	2.90		131.43	2.73	143.81		143.38	143.81	143.67	4.43			-0.51	-0.08	-0.15
5	9.0	Max	233.69	4.86		225.60	4.69	229.14		231.83	245.57	235.51	7.25			-1.79	-0.41	-0.85
		Mean	168.77	3.51		160.88	3.35	172.40		170.59	180.12	174.37	5.37			-0.89	-0.16	-0.48
		Min	122.41	2.55		112.94	2.35	134.00		134.92	140.32	136.40	4.20			-0.26	-0.07	-0.02
6	11.0	Max	188.69	3.92		179.00	3.72	162.03		141.64	175.25	159.64	4.92			-1.16	-0.17	-0.61
		Mean	147.21	3.06		139.43	2.90	133.07		113.48	138.10	128.22	3.95			-0.69	-0.07	-0.35
		Min	116.71	2.43		107.75	2.24	103.56		84.53	113.35	100.48	3.09			-0.31	-0.02	-0.13
7	13.0	Max	235.27	4.89		230.22	4.79	170.23		153.79	177.70	167.24	5.15			-1.81	-0.17	-0.99
		Mean	152.17	3.17		147.63	3.07	138.54		122.41	141.20	134.05	4.13			-0.69	-0.07	-0.39
		Min	119.85	2.49		122.16	2.54	111.84		100.09	115.11	109.01	3.36			-0.25	-0.02	-0.11
8	15.0	Max	217.78	4.53		201.84	4.20	175.95		159.72	186.54	174.07	5.36			-1.53	-0.18	-0.85
		Mean	168.40	3.50		161.26	3.35	142.94		129.77	148.88	140.53	4.33			-0.86	-0.08	-0.47
		Min	141.86	2.95		134.00	2.79	118.29		111.28	129.74	119.77	3.69			-0.48	-0.02	-0.24

Max = highest recorded velocity, most negative P and ΔP ; Mean = average velocity, average P and ΔP ; Min = lowest recorded velocity, least negative P and ΔP .

N.R. = No reverse flow detected.

*** = values not determinable from recorded data.

Table 5
Air Vent Point Velocities and Chamber Pressures
Series D

Test No.	Gate Opening ft.	Item*	Center Sluice			Right Sluice			RV6 fps	ΔP, Feet of Water	P, psi
			RV1 fps	RV2 fps	RV3 fps	RV4 fps	RV5 fps	RV6 fps			
9	1.0	Max	139.88	N.R.**	68.49	62.95	70.64	67.36	N.R.**	-0.50	-0.32
		Mean	118.29	2.46	45.48	39.19	44.51	43.06	1.33	-0.34	-0.22
		Min	103.35	2.15	29.18	23.61	25.38	26.06	0.80	-0.21	-0.16
8	3.0	Max	148.36	3.09	139.43	120.37	136.29	132.03	4.07	-0.68	-0.42
		Mean	130.73	2.72	120.37	107.20	120.88	116.15	3.58	-0.52	-0.30
		Min	122.54	2.55	98.85	86.70	97.97	94.51	2.91	-0.37	-0.22
7	5.0	Max	195.14	4.06	229.68	214.31	235.54	226.51	6.98	-1.22	-0.67
		Mean	166.92	3.47	202.15	186.21	211.43	199.93	6.16	-0.92	-0.49
		Min	147.63	3.07	181.49	168.77	191.94	180.73	5.57	-0.70	-0.37
6	7.0	Max	238.02	4.95	264.66	257.15	284.15	268.65	8.27	-1.87	-1.04
		Mean	200.61	4.17	221.17	209.67	236.59	222.48	6.85	-1.33	-0.69
		Min	178.14	3.71	192.54	177.70	200.00	190.08	5.85	-0.98	-0.46
5	9.0	Max	288.47	6.00	282.18	265.68	304.96	284.27	8.76	-2.93	-1.50
		Mean	235.27	4.89	231.56	211.14	239.96	227.55	7.01	-1.92	-0.95
		Min	184.54	3.84	197.19	186.21	201.54	194.98	6.01	-1.05	-0.48
4	11.0	Max	244.91	5.09	307.99	265.39	298.60	290.66	8.95	-2.17	-1.16
		Mean	192.74	4.01	268.00	227.51	255.46	250.32	7.71	-1.28	-0.68
		Min	158.11	3.29	232.89	200.61	222.84	218.78	6.74	-0.73	-0.37
3	13.0	Max	257.15	5.35	229.41	218.92	243.80	230.71	7.11	-2.20	-1.21
		Mean	201.54	4.19	206.39	192.74	220.04	206.39	6.36	-1.34	-0.71
		Min	172.62	3.59	193.55	176.83	212.60	194.33	5.99	-0.85	-0.44
2	11/16ft	Max	192.74	4.01	164.68	157.37	178.40	166.82	5.14	-1.16	-0.73
		Mean	163.93	3.41	131.67	119.85	135.38	128.97	3.97	-0.78	-0.46
		Min	144.67	3.01	116.71	103.95	113.48	111.38	3.43	-0.42	-0.26
1	12/15ft	Max	196.40	4.09	181.83	171.31	195.61	182.92	5.63	-1.25	-0.74
		Mean	168.03	3.50	138.10	123.42	162.94	134.82	4.15	-0.87	-0.48
		Min	135.38	2.82	113.01	102.90	116.98	110.96	3.42	-0.45	-0.24

* Max = highest recorded velocity, most negative P and ΔP; Mean = average velocity, average P and ΔP; Min = lowest recorded velocity, least negative P and ΔP.

** N.R. = No reverse flow detected.

† Test 2: Center sluice gate opening, 16 ft; right sluice gate opening, 11 ft.

†† Test 1: Center sluice gate opening, 15 ft; right sluice gate opening, 12 ft.

Table 6
Air Discharge

Test No.	Start Time	Gate Opening ft	Water Q cfs	Center Sluice*				Right Sluice			
				Max cps	Mean cfs	Min cfs	f _G ** cps	Max cfs	Mean cfs	Min cfs	f _G ** cps
Series A, 9/21/82											
1	1044	1.0	800	1,807	1,446	1,281	0.2	(-)	907†		
2	1108	3.0	2,400	1,949	1,718	1,539	0.9	(-)	1,171		
3	1125	5.0	3,800	3,363	2,825	2,268	0.3	(-)	1,009		
5	1355	7.0	5,200	4,628	3,529	2,579	0.1	--††			
6	1408	9.0	6,800	5,822	4,505	3,123	0.2	(-)	319		
7	1422	11.0	8,700	5,213	4,298	3,222	0.5	(-)	628		
8	1441	13.0	10,800	5,251	4,146	3,422	0.5	(-)	990		
9	1509	15.0	13,500	5,637	4,513	3,848	0.6	(-)	1,063		
Series B, 9/21/82											
8	1709	1.0	800	2,655	2,277	2,029	0.2		0		
7	1657	3.0	2,400	3,269	2,812	2,485	0.1		0		
6	1640	5.0	3,800	4,748	3,980	3,556	0.2		0		
5	1624	7.0	5,200	5,823	4,614	3,584	0.2		0		
4	1615	9.0	6,800	6,470	5,412	4,427	0.2		0		
3	1603	11.0	8,700	6,365	5,132	4,271	0.5		0		
2	1556	13.0	10,800	5,578	4,875	4,341	0.5		0		
1	1543	15.0	13,500	5,274	4,506	4,011	0.3		0		
Series C, 9/22/82											
1	1007	1.0	800	2,026	1,675	1,197	1.0	1,127	981	801	1.0
2	1031	3.0	2,400	2,313	2,072	1,889	0.9	1,997	1,768	1,581	1.0
3	1110	5.0	3,800	3,645	3,073	2,752	0.5	3,697	3,080	2,450	0.8
4	1131	7.0	5,200	5,378	3,999	3,260	0.4	5,833	4,441	3,299	0.3
5	1141	9.0	6,800	5,523	3,964	2,830	0.3	5,407	4,004	3,132	0.3
6	1205	11.0	8,700	4,422	3,447	2,699	0.5	3,665	2,944	2,307	0.4
7	1239	13.0	10,800	5,598	3,605	2,910	0.5	3,840	3,078	2,503	0.9
8	1253	15.0	13,500	5,046	3,965	3,317	0.7	3,997	3,227	2,750	1.0
Series D, 9/22/82											
9		1.0	800	3,208	2,691	2,399	0.2	1,547	989	598	0.2
8		3.0	2,400	3,579	3,133	2,900	0.2	3,031	2,667	2,170	0.1
7	1403	5.0	3,800	4,658	3,992	3,592	0.3	5,201	4,590	4,150	0.2
6	1354	7.0	5,200	5,637	4,768	4,226	0.3	6,168	5,108	4,364	0.1
5	1342	9.0	6,800	6,867	5,565	4,200	0.2	6,527	5,225	4,477	0.2
4	1329	11.0	8,700	5,993	4,682	3,791	0.2	6,674	5,747	5,023	0.5
3	1318	13.0	10,800	6,141	4,757	4,026	0.4	5,297	4,739	4,462	0.3
2	1308	16.0/11.0‡	15,500/8,700	4,545	3,826	3,295	0.7	3,830	2,961	2,557	0.9
1	1302	15.0/12.0‡	13,500/9,600	4,663	3,955	3,148	0.3	4,200	3,095	2,548	0.3

* Values shown are the sum of both vents (i.e., Q = RV1 + LV1).
 ** f_G = gusting frequency (air discharge, aerator pressure, and differential pressure), cycles per second.
 † (-) indicates reverse (downstream) airflow.
 †† -- = not determinable.
 ‡ Test 2: Center sluice, 16-ft gate opening; 15,500 cfs; right sluice, 11-ft gate opening, 8700 cfs.
 Test 1: Center sluice, 15-ft gate opening, 13,500 cfs; right sluice, 12-ft gate opening, 9600 cfs.

Table 7
Aerator Slot Pressures, Feet of Water
Series A

Test No.	Gate Opening ft	Item*	Air Discharge cfs	Transducer Location					
				AR1	AR2	AR3	AR4	AR5	AR6
1	1.0	Max	1,807	-0.44	-0.37	-0.37	-1.15	-1.08	-0.44
		Mean	1,446	-0.30	-0.23	-0.25	-0.95	-0.95	-0.30
		Min	1,281	-0.18	-0.14	-0.16	-0.58	-0.72	-0.16
2	3.0	Max	1,949	-0.44	-0.30	-0.42	-1.11	-1.02	-0.44
		Mean	1,718	-0.35	-0.16	-0.21	-0.97	-0.90	-0.28
		Mean	1,539	-0.12	-0.07	-0.09	-0.72	-0.60	-0.12
3	5.0	Max	3,363	-1.11	-1.02	-1.22	-1.96	-1.50	-1.25
		Mean	2,825	-0.58	-0.46	-0.67	-1.27	-0.95	-0.55
		Min	2,268	-0.18	-0.16	-0.35	-0.81	-0.53	-0.14
5	7.0	Max	4,628	-2.33	-2.08	-2.08	-2.81	-2.61	-2.19
		Mean	3,529	-1.52	-1.27	-1.31	-1.98	-1.87	-1.25
		Min	2,579	-0.92	-0.76	-0.81	-1.29	-1.34	-0.69
6	9.0	Max	5,822	-3.32	-3.07	-3.02	-3.85	-3.30	-3.05
		Mean	4,505	-2.15	-1.94	-1.89	-2.70	-2.38	-1.94
		Min	3,123	-1.08	-0.99	-0.92	-1.66	-1.57	-0.95
7	11.0	Max	5,213	-2.19	-2.19	-2.19	-2.88	-2.61	-2.15
		Mean	4,298	-1.50	-1.52	-1.48	-2.17	-2.05	-1.50
		Min	3,222	-0.58	-0.60	-0.58	-1.18	-1.20	-0.58
8	13.0	Max	5,251	-1.96	-2.03	-1.96	-2.72	-2.51	-2.15
		Mean	4,146	-1.08	-1.13	-1.06	-1.85	-1.73	-1.13
		Min	3,422	-0.48	-0.51	-0.42	-1.18	-1.11	-0.46
9	15.0	Max	5,637	-2.12	-2.17	-2.10	-2.88	-2.58	-2.17
		Mean	4,513	-1.20	-1.25	-1.18	-2.03	-1.85	-1.31
		Min	3,848	-0.72	-0.76	-0.69	-1.41	-1.34	-0.76

* Max = highest recorded discharge, most negative aerator pressure; Mean = average discharge, average aerator pressure; Min = lowest recorded discharge, least negative aerator pressure.

Table 8
Aerator Slot Pressures, Feet of Water
Series B

Test No.	Gate Opening ft	Item*	Air Discharge cfs	Transducer Location					
				AR1	AR2	AR3	AR4	AR5	AR6
8	1.0	Max	2,655	-0.53	-0.55	-0.65	-1.43	-1.45	-0.65
		Mean	2,277	-0.39	-0.42	-0.48	-1.22	-1.25	-0.48
		Min	2,029	-0.25	-0.28	-0.32	-0.81	-0.95	-0.35
7	3.0	Max	3,269	-0.76	-0.72	-0.95	-1.57	-1.82	-0.90
		Mean	2,812	-0.60	-0.53	-0.69	-1.38	-1.48	-0.74
		Min	2,485	-0.35	-0.37	-0.44	-1.13	-1.18	-0.53
6	5.0	Max	4,748	-1.89	-1.75	-2.01	-2.49	-2.40	-1.96
		Mean	3,980	-1.43	-1.31	-1.55	-2.03	-1.98	-1.36
		Min	3,556	-1.06	-1.02	-1.20	-1.57	-1.64	-1.02
5	7.0	Max	5,823	-2.77	-2.70	-2.93	-3.41	-3.11	-2.81
		Mean	4,614	-1.94	-1.80	-1.98	-2.49	-2.35	-1.80
		Min	3,584	-1.27	-1.18	-1.20	-1.78	-1.66	-1.11
4	9.0	Max	6,470	-3.11	-3.07	-3.09	-3.92	-3.55	-3.21
		Mean	5,412	-2.45	-2.38	-2.45	-3.02	-2.81	-2.33
		Min	4,427	-1.78	-1.68	-1.73	-2.21	-2.26	-1.61
3	11.0	Max	6,365	-3.41	-3.30	-3.30	-4.04	-3.53	-3.32
		Mean	5,132	-2.28	-2.17	-2.21	-2.86	-2.70	-2.19
		Min	4,271	-1.61	-1.50	-1.55	-2.12	-2.10	-1.43
2	13.0	Max	5,578	-2.10	-2.17	-2.15	-2.95	-2.70	-2.21
		Mean	4,875	-1.48	-1.59	-1.55	-2.33	-2.17	-1.59
		Min	4,341	-1.11	-1.18	-1.15	-1.91	-1.82	-1.18
1	15.0	Max	5,274	-1.73	-1.78	-1.73	-2.63	-2.33	-1.87
		Mean	4,506	-1.27	-1.34	-1.29	-2.15	-1.91	-1.43
		Min	4,011	-0.99	-1.04	-0.99	-1.71	-1.57	-1.06

* Max = highest recorded discharge, most negative aerator pressure; Mean = average discharge, average aerator pressure; Min = lowest recorded discharge, least negative aerator pressure.

Table 9
Aerator Slot Pressures, Feet of Water
Series C

Test No.	Gate Opening ft	Item*	Air Discharge cfs	Transducer Location					
				AR1	AR2	AR3	AR4	AR5	AR6
1	1.0	Max	2,026	-0.46	-0.46	-0.44	-1.18	-1.27	-0.48
		Mean	1,675	-0.30	-0.30	-0.28	-0.99	-1.04	-0.32
		Min	1,197	-0.18	-0.18	-0.16	-0.81	-0.74	-0.18
2	3.0	Max	2,313	-0.44	-0.37	-0.48	-1.25	-1.38	-0.90
		Mean	2,072	-0.23	-0.23	-0.25	-0.97	-1.08	-0.28
		Min	1,889	-0.05	-0.07	-0.02	-0.74	-0.76	-0.09
3	5.0	Max	3,645	-0.97	-0.92	-0.99	-1.73	-1.61	-0.99
		Mean	3,073	-0.58	-0.53	-0.69	-1.22	-1.25	-0.53
		Min	2,752	-0.16	-0.16	-0.32	-0.69	-0.76	-0.07
4	7.0	Max	5,378	-1.85	-1.82	-1.87	-2.58	-2.49	-1.87
		Mean	3,999	-1.02	-0.99	-1.02	-1.66	-1.59	-0.95
		Min	3,260	-0.55	-0.48	-0.51	-1.11	-1.11	-0.32
5	9.0	Max	5,523	-1.96	-1.96	-1.94	-2.72	-2.45	-2.03
		Mean	3,964	-0.99	-0.97	-0.95	-1.64	-1.52	-0.92
		Min	2,830	-0.23	-0.21	-0.18	-0.81	-0.69	-0.09
6	11.0	Max	4,422	-1.57	-1.55	-1.59	-2.17	-2.15	-1.61
		Mean	3,447	-1.04	-1.06	-1.06	-1.68	-1.66	-1.04
		Min	2,699	-0.58	-0.55	-0.60	-1.06	-1.22	-0.51
7	13.0	Max	5,598	-2.47	-2.45	-2.45	-3.21	-3.00	-2.63
		Mean	3,605	-1.13	-1.11	-1.11	-1.80	-1.71	-1.15
		Min	2,910	-0.53	-0.48	-0.48	-1.22	-1.25	-0.51
8	15.0	Max	5,046	-2.08	-2.01	-2.03	-2.93	-2.58	-2.42
		Mean	3,965	-1.27	-1.20	-1.22	-1.98	-1.87	-1.34
		Min	3,317	-0.81	-0.74	-0.76	-1.50	-1.50	-0.88

* Max = highest recorded discharge, most negative aerator pressure; Mean = average discharge, average aerator pressure; Min = lowest recorded discharge, least negative aerator pressure.

Table 10
Aerator Slot Pressures, Feet of Water
Series D

Test No.	Gate Opening ft	Item*	Air Discharge cfs	Transducer Location					
				AR1	AR2	AR3	AR4	AR5	AR6
9	1.0	Max	3,208	-0.67	-0.65	-0.74	-1.48	-1.61	-0.81
		Mean	2,691	-0.46	-0.46	-0.53	-1.27	-1.31	-0.58
		Min	2,399	-0.32	-0.32	-0.39	-0.85	-0.97	-0.42
8	3.0	Max	3,579	-1.04	-0.88	-1.11	-1.89	-0.96	-1.38
		Mean	3,133	-0.81	-0.67	-0.88	-1.50	-1.61	-0.88
		Min	2,900	-0.60	-0.46	-0.62	-1.20	-1.38	-0.65
7	5.0	Max	4,658	-1.71	-1.64	-1.85	-2.51	-2.40	-1.80
		Mean	3,992	-1.38	-1.25	-1.50	-1.98	-2.03	-1.34
		Min	3,592	-1.04	-0.97	-1.22	-1.64	-1.61	-1.02
6	7.0	Max	5,637	-2.45	-2.38	-2.38	-3.21	-2.95	-2.72
		Mean	4,768	-1.91	-1.78	-1.89	-2.42	-2.35	-1.78
		Min	4,226	-1.41	-1.31	-1.38	-1.96	-1.85	-1.29
5	9.0	Max	6,867	-3.55	-3.37	-3.51	-4.18	-3.58	-3.41
		Mean	5,565	-2.47	-2.38	-2.42	-3.05	-2.79	-2.38
		Min	4,200	-1.50	-1.36	-1.41	-2.10	-1.96	-1.38
4	11.0	Max	5,993	-2.79	-2.75	-2.77	-3.39	-3.02	-2.75
		Mean	4,682	-1.80	-1.75	-1.78	-2.45	-2.31	-1.80
		Min	3,791	-1.18	-1.13	-1.13	-1.75	-1.71	-1.13
3	13.0	Max	6,141	-2.93	-2.91	-2.93	-3.71	-3.30	-3.00
		Mean	4,757	-1.80	-1.80	-1.82	-2.51	-2.40	-1.87
		Min	4,026	-1.20	-1.20	-1.22	-1.87	-1.82	-1.22
2	16.0	Max	4,545	-1.75	-1.66	-1.68	-2.51	-2.31	-1.87
		Mean	3,826	-1.29	-1.20	-1.22	-1.96	-1.85	-1.34
		Min	3,925	-0.83	-0.72	-0.76	-1.48	-1.43	-0.78
1	15.0	Max	4,663	-1.82	-1.80	-1.78	-2.65	-2.42	-2.08
		Mean	3,955	-1.31	-1.29	-1.29	-2.03	-1.94	-1.41
		Min	3,148	-0.83	-0.78	-0.78	-1.43	-1.45	-0.83

* Max = highest recorded discharge, most negative aerator pressure; Mean = average discharge, average aerator pressure; Min = lowest recorded discharge, least negative aerator pressure.

Table 11
Center Sluice Invert Pressures, Velocities, and
Series A

Test No.	Gate Opening ft	Water Q cfs	Item*	Transdu		
				SI5	SI4	
1	1.0	800	V	84.27	85.88	
			K	0.265	0.256	
			H	1.59	0.0	
			M	-1.50	-1.38	
			L	-5.24	-4.82	
			P/P	4.15	4.82	
2	3.0	2,400	V	111.4	110.9	1
			K	0.185	0.162	
			H	9.37	4.94	
			M	4.87	0.28	
			L	1.40	-3.09	
			P/P	6.57	5.77	
3	5.0	3,800	V	109.81	108.85	1
			K	0.214	0.161	
			H	15.69	5.56	
			M	9.44	-1.07	
			L	1.62	-6.99	
			P/P	8.51	10.96	
5	7.0	5,200	V	112.92	111.71	1
			K	0.139	0.124	
			H	3.02	0.05	
			M	-3.23	-6.67	
			L	-8.01	-12.62	
			P/P	8.94	10.67	
6	9.0	6,800	V	117.29	115.91	1
			K	--**	0.115	
			H	--	-0.30	
			M	--	-6.78	
			L	--	-13.52	
			P/P	--	11.97	
7	11.0	8,700	V	121.42	119.97	1
			K	0.126	0.121	
			H	2.38	2.03	
			M	-1.89	-3.65	
			L	-7.04	-9.67	
			P/P	7.50	8.94	

(Continued)

Note: All pressures given in feet of water.

* V = average velocity, fps; K = cavitation index
neous pressure; M = mean pressure; L = lowest in
and P/P = greatest peak-peak pressure.

** -- = data indeterminate.

Table 11 (Concluded)

Test No.	Gate Opening ft	Water Q cfs	Item	Transducer Station				
				SL5	SL4	SL3	SL2	SL1
8	13.0	10,800	V	123.02	121.15	120.32	118.10	115.23
			K	0.137	0.127	0.161	0.161	0.125
			H	6.04	3.11	8.84	6.97	-4.15
			M	1.49	-1.80	5.40	4.08	-5.03
			L	-3.67	-7.27	0.71	0.22	-6.21
			P/P	7.71	7.50	6.46	4.61	2.06
9	15.0	14,900	V	125.21	123.58	122.36	120.04	117.01
			K	0.212	0.123	0.158	0.166	0.123
			H	26.53	3.74	8.12	9.60	-3.53
			M	20.95	-1.50	5.98	6.46	-4.64
			L	17.14	-4.48	3.55	4.34	-5.88
			P/P	8.07	6.57	3.86	4.38	2.35

Table 12
Center Sluice Invert Pressures, Velocities, and Cavitation Indices
Series B

Test No.	Gate Opening ft	Water Q cfs	Item*	Transducer Station				
				SL5	SL4	SL3	SL2	SL1
8	1.0	800	V	84.27	85.88	91.93	97.40	105.86
			K	0.356	0.262	0.227	0.204	0.173
			H	10.70	0.36	-0.20	0.51	0.26
			M	8.60	-0.70	-0.99	-0.61	-0.56
			L	7.22	-1.56	-2.00	-1.67	-0.90
			P/P	0.31	1.69	1.31	1.70	1.20
7	3.0	2,400	V	111.4	110.9	110.6	110.4	110.9
			K	0.209	0.151	0.171	0.166	0.155
			H	13.80	1.51	4.41	5.46	0.31
			M	9.54	-1.80	1.70	0.67	-1.04
			L	6.42	-6.45	-1.14	-2.33	-1.91
			P/P	6.25	7.00	5.38	6.75	3.22
6	5.0	3,800	V	109.81	108.85	108.23	106.99	105.93
			K	0.209	0.143	0.190	0.169	0.149
			H	14.40	2.81	9.03	5.31	-3.87
			M	8.47	-4.43	3.80	-0.72	-4.68
			L	4.12	-1.07	-0.99	-6.69	-5.63
			P/P	8.00	11.50	8.50	10.50	1.06
5	7.0	5,200	V	112.92	111.71	110.87	109.02	107.00
			K	0.197	0.124	0.192	0.160	0.129
			H	14.10	0.63	11.10	5.38	-6.25
			M	8.36	-6.77	5.92	-1.27	-7.84
			L	3.36	-12.70	-0.15	-7.27	-9.34
			P/P	10.58	11.10	9.83	10.25	3.10
4	9.0	6,800	V	117.29	115.91	114.99	112.94	110.54
			K	0.183	0.116	0.178	0.148	0.122
			H	13.50	-1.09	10.50	4.87	-6.25
			M	8.39	-6.48	5.95	-1.34	-7.52
			L	3.24	-12.60	1.49	-7.20	-9.50
			P/P	7.50	11.10	7.38	9.50	1.96
3	11.0	8,700	V	121.42	119.97	118.85	116.83	114.22
			K	0.184	0.114	0.164	0.140	0.116
			H	16.90	0.73	9.40	4.65	-6.14
			M	11.40	-5.21	5.25	-1.11	-7.16
			L	6.21	-12.80	0.65	-5.23	-8.83
			P/P	7.88	9.06	7.50	8.31	2.69

(Continued)

Note: All pressures given in feet of water.

* V = average velocity, fps; K = cavitation index; H = highest instantaneous pressure; M = mean pressure; L = lowest instantaneous pressure; and P/P = greatest peak-peak pressure.

Table 12 (Concluded)

Test No.	Gate Opening ft	Water Q cfs	Item	Transducer Station				
				SL5	SL4	SL3	SL2	SL1
2	13.0	11,900	V	123.02	121.15	120.32	118.10	115.23
			K	0.204	0.126	0.166	0.163	0.127
			H	22.50	3.17	10.20	7.50	-3.62
			M	17.30	-1.99	6.56	4.50	-4.48
			L	12.50	-6.40	1.46	2.18	-5.54
			P/P	10.00	8.63	5.50	5.38	1.92
1	15.0	14,900	V	125.21	123.58	122.36	120.04	117.01
			K	0.218	0.122	0.158	0.166	0.122
			H	27.00	0.81	8.08	10.00	-3.98
			M	22.40	-1.70	6.07	6.33	-4.79
			L	19.30	-4.21	3.76	4.38	-5.60
			P/P	6.41	6.25	3.53	4.69	1.62

Table 13
Center Sluice Invert Pressures, Velocities, and Cavitation Indices
Series C

Test No.	Gate Opening ft	Water Q cfs	Item*	Transducer Station				
				SL5	SL4	SL3	SL2	SL1
1	1.0	800	V	84.27	85.88	91.93	97.40	105.86
			K	0.268	0.261	0.236	0.203	0.172
			H	1.85	0.43	1.21	0.44	-0.21
			M	-1.13	-0.75	0.24	-0.73	-0.79
			L	-2.28	-1.76	-1.32	-1.81	-1.34
			P/P	3.78	1.94	1.78	1.80	0.73
2	3.0	2,400	V	111.4	110.9	110.6	110.4	110.9
			K	0.161	0.158	0.177	0.172	0.156
			H	5.44	2.67	5.69	5.47	-0.10
			M	0.23	-0.47	2.88	1.82	-0.85
			L	-2.90	-4.81	0.25	-0.51	-1.66
			P/P	7.28	5.16	4.80	5.38	1.30
3	5.0	3,800	V	109.81	108.85	108.23	106.99	105.93
			K	0.165	0.154	0.207	0.189	0.167
			H	6.36	4.33	12.00	10.40	-0.73
			M	0.27	-2.40	6.90	2.89	-1.63
			L	-4.70	-8.87	0.71	-3.13	-2.53
			P/P	9.78	11.20	8.80	12.50	1.69
4	7.0	5,200	V	112.92	111.71	110.87	109.02	107.00
			K	0.152	0.138	0.206	0.182	0.158
			H	5.38	2.62	13.20	9.40	-1.35
			M	-0.68	-4.05	8.65	2.82	-2.67
			L	-7.11	-9.51	1.42	-4.01	-4.58
			P/P	10.88	11.38	10.45	11.25	2.47
5	9.0	6,800	V	117.29	115.91	114.99	112.94	110.54
			K	0.195	0.135	0.189	0.177	0.145
			H	6.73	4.60	13.20	9.77	-1.87
			M	0.36	-2.48	8.04	4.29	-3.21
			L	-5.81	-9.78	2.74	-0.95	-4.94
			P/P	8.28	11.78	7.38	8.56	2.66
6	11.0	8,700	V	121.42	119.97	118.85	116.83	114.22
			K	0.127	0.122	0.163	0.146	0.121
			H	2.90	2.45	9.00	4.43	-5.11
			M	-1.75	-3.37	5.00	0.24	-6.11
			L	-6.84	-8.26	-0.05	-2.76	-7.54
			P/P	7.88	9.95	7.78	5.43	1.81

(Continued)

Note: All pressures given in feet of water.

* V = average velocity, fps; K = cavitation index; H = highest instantaneous pressure; M = mean pressure; L = lowest instantaneous pressure; and P/P = greatest peak-peak pressure.

Table 13 (Concluded)

Test No.	Gate Opening ft	Water Q cfs	Item	Transducer Station				
				SL5	SL4	SL3	SL2	SL1
7	13.0	10,800	V	123.02	121.15	120.32	118.10	115.23
			K	0.126	0.117	0.156	0.140	0.115
			H	3.95	1.81	8.22	4.50	-5.99
			M	-1.19	-4.03	4.37	-0.39	-6.91
			L	-6.66	-9.22	-0.36	-2.76	-8.32
			P/P	8.13	7.30	7.80	7.29	1.88
8	15.0	13,500	V	125.21	123.58	122.36	120.04	117.01
			K	0.131	0.114	0.153	0.147	0.111
			H	8.14	0.91	7.35	5.52	-6.04
			M	1.14	-3.77	4.84	2.09	-7.03
			L	-2.71	-7.67	2.28	-0.87	-8.06
			P/P	9.75	7.15	4.60	4.35	1.75

Table 14
Center Sluice Invert Pressures, Velocities, and Cavitation Indices
Series D

Test No.	Gate Opening ft	Water Q cfs	Item*	Transducer Station				
				SL5	SL4	SL3	SL2	SL1
9	1.0	800	V	84.27	85.88	91.93	97.40	105.86
			K	0.259	0.264	0.240	0.207	0.116
			H	-0.12	0.69	1.72	1.38	1.08
			M	-2.07	-0.43	0.80	-0.20	-0.04
			L	-3.15	-1.44	-0.10	-1.31	-1.05
			P/P	2.85	1.66	1.38	1.83	2.00
8	3.0	2,400	V	111.4	110.9	110.6	110.4	110.9
			K	0.146	0.149	0.178	0.161	0.149
			H	3.40	1.87	6.39	3.64	-1.34
			M	-2.62	-2.16	3.05	-0.15	-2.18
			L	-6.05	-6.51	-0.15	-3.71	-3.02
			P/P	8.63	6.95	5.68	7.38	1.68
7	5.0	3,800	V	109.81	108.85	108.23	106.99	105.93
			K	0.141	0.134	0.201	0.161	0.151
			H	2.53	0.59	10.50	5.89	-3.41
			M	-4.36	-6.06	5.77	-2.01	-4.33
			L	-10.10	-12.80	0.20	-7.64	-5.48
			P/P	9.70	12.03	9.38	11.50	1.06
6	7.0	5,200	V	112.92	111.71	110.87	109.02	107.00
			K	0.129	0.124	0.196	0.158	0.140
			H	0.93	-0.21	11.20	6.47	-4.75
			M	-5.07	-6.65	6.69	-1.55	-5.79
			L	-10.40	-12.40	1.22	-8.22	-7.54
			P/P	8.50	10.48	9.69	12.00	1.79
5	9.0	6,800	V	117.29	115.91	114.99	112.94	110.54
			K	0.119	0.113	--**	0.150	0.121
			H	1.17	-0.64	--	5.89	-5.79
			M	-5.33	-7.15	--	-1.01	-7.70
			L	-10.80	-13.70	--	-6.76	-11.40
			P/P	9.00	12.50	--	9.63	3.94
4	11.0	8,700	V	121.42	119.97	118.85	116.83	114.22
			K	0.122	0.119	0.165	0.144	0.118
			H	2.15	2.07	10.90	4.79	-5.31
			M	-2.78	-4.02	5.56	-0.23	-6.88
			L	-8.35	-11.70	-1.31	-3.92	-8.51
			P/P	7.75	8.88	8.25	7.81	2.75

(Continued)

Note: All pressures given in feet of water.

* V = average velocity; fps, K = cavitation index; H = highest instantaneous pressure; M = mean pressure; L = lowest instantaneous pressure; and P/P = greatest peak-peak pressure.

** -- = data indeterminate.

Table 14 (Concluded)

Test No.	Gate Opening ft	Water Q cfs	Item	Transducer Station				
				SL5	SL4	SL3	SL2	SL1
3	13.0	10,800	V	123.02	121.15	120.32	118.10	115.23
			K	0.122	0.115	0.158	0.141	0.113
			H	4.44	1.12	9.76	4.29	-6.10
			M	-2.01	-4.44	4.89	-0.07	-7.36
			L	-7.35	-9.96	1.21	-2.23	-9.26
			P/P	9.50	7.13	7.25	5.13	1.88
2	16.0	15,500	V	125.44	123.83	122.58	120.21	117.06
			K	0.136	0.112	0.155	0.152	0.106
			H	7.65	0.0	7.89	7.42	-6.98
			M	2.63	-4.09	5.54	3.36	-8.10
			L	-1.11	-7.41	2.43	0.22	-11.25
			P/P	7.25	5.75	5.00	6.25	4.00
1	15.0	13,500	V	125.21	123.58	122.36	120.04	117.01
			K	0.129	0.112	0.152	0.144	0.109
			H	5.99	0.80	7.23	5.00	-6.57
			M	0.78	-4.06	4.76	1.46	-7.62
			L	-3.27	-7.25	1.47	-4.69	-8.58
			P/P	7.63	7.00	5.06	10.00	2.00

Table 15
Service Gallery Vibration
Series A

Test No.	Gate Opening ft	Transducer Location	Acceleration, g's			Freq Hz	Displ μ -ft*
			Max	Min	P-P		
1	1.0	Vertical	0.001	-0.001	0.002	78	0.27
		Longitudinal	0.012	-0.014	0.026	78	3.48
		Transverse	0.016	-0.018	0.030	78	4.02
2	3.0	Vertical	0.001	-0.002	0.003	78	0.40
		Longitudinal	0.013	-0.014	0.027	78	3.62
		Transverse	0.015	-0.014	0.028	78	3.75
3	5.0	Vertical	0.013	-0.013	0.018	99	1.50
		Longitudinal	0.034	-0.024	0.053	78	7.12
		Transverse	0.082	-0.072	0.128	170	3.61
5	7.0	Vertical	0.006	-0.034	0.040	170	1.13
		Longitudinal	0.037	-0.039	0.073	156	2.44
		Transverse	0.10	-0.087	0.187	163	5.74
6	9.0	Vertical	0.007	-0.020	0.027	223	0.44
		Longitudinal	0.060	-0.070	0.122	156	4.09
		Transverse	0.239	-0.172	0.411	160	13.10
7	11.0	Vertical	0.005	-0.006	0.010	151	0.36
		Longitudinal	0.040	-0.045	0.085	156	2.85
		Transverse	0.084	-0.087	0.171	156	5.73
8	13.0	Vertical	0.008	-0.009	0.017	145	0.66
		Longitudinal	0.058	-0.057	0.105	125	5.48
		Transverse	0.080	-0.087	0.167	150	6.05
9	15.0	Vertical	0.006	-0.009	0.015	113	0.96
		Longitudinal	0.047	-0.053	0.088	205	1.71
		Transverse	0.097	-0.120	0.217	156	7.27

Note: Max = greatest instantaneous acceleration (+) direction; Min = greatest instantaneous acceleration (-) direction; P-P = greatest peak-peak acceleration.

* μ -ft = 0.000001 ft.

Table 16
Service Gallery Vibration
Series B

Test No.	Gate Opening ft	Transducer Location	Acceleration, g's			Freq Hz	Displ μ -ft*
			Max	Min	P-P		
8	1.0	Vertical	0.001	-0.001	0.002	79	0.26
		Longitudinal	0.013	-0.015	0.020	79	2.61
		Transverse	0.015	-0.014	0.030	79	3.85
7	3.0	Vertical	0.001	-0.001	0.002	79	0.26
		Longitudinal	0.018	-0.019	0.032	79	4.18
		Transverse	0.017	-0.019	0.036	79	4.70
6	5.0	Vertical	0.003	-0.025	0.028	155	0.95
		Longitudinal	0.021	-0.025	0.046	155	1.56
		Transverse	0.072	-0.055	0.127	158	4.15
5	7.0	Vertical	0.003	-0.010	0.013	78	1.74
		Longitudinal	0.032	-0.023	0.055	78	7.37
		Transverse	0.095	-0.096	0.191	164	5.79
4	9.0	Vertical	0.007	-0.007	0.014	160	0.45
		Longitudinal	0.054	-0.049	0.088	206	1.69
		Transverse	0.122	-0.109	0.231	161	7.26
3	11.0	Vertical	0.005	-0.005	0.010	150	0.36
		Longitudinal	0.059	-0.040	0.100	210	1.85
		Transverse	0.055	-0.080	0.130	161	4.09
2	13.0	Vertical	0.006	-0.007	0.011	145	0.43
		Longitudinal	0.045	-0.052	0.096	125	5.00
		Transverse	0.108	-0.091	0.188	150	6.81
1	15.0	Vertical	0.006	-0.007	0.011	115	0.70
		Longitudinal	0.051	-0.053	0.100	205	1.94
		Transverse	0.075	-0.080	0.149	158	4.86

Note: Max = greatest instantaneous acceleration (+) direction; Min = greatest instantaneous acceleration (-) direction; P-P = greatest peak-peak acceleration.

* μ -ft = 0.000001 ft.

Table 17
Service Gallery Vibration
Series C

Test No.	Gate Opening ft	Transducer Location	Acceleration, g's			Freq Hz	Displ μ -ft*
			Max	Min	P-P		
1	1.0	Vertical	0.001	-0.001	0.002	78	0.27
		Longitudinal	0.001	-0.001	0.002	78	0.27
		Transverse	0.001	-0.001	0.002	78	0.27
2	3.0	Vertical	0.001	-0.001	0.002	156	0.07
		Longitudinal	0.001	-0.001	0.002	156	0.07
		Transverse	0.001	-0.001	0.002	145	0.08
3	5.0	Vertical	0.001	-0.003	0.004	156	0.13
		Longitudinal	0.001	-0.002	0.003	78	0.40
		Transverse	0.002	-0.003	0.005	145	0.19
4	7.0	Vertical	0.004	-0.012	0.016	221	0.27
		Longitudinal	0.003	-0.003	0.006	221	0.01
		Transverse	0.007	-0.009	0.016	128	0.80
5	9.0	Vertical	0.007	-0.012	0.019	218	0.33
		Longitudinal	0.004	-0.005	0.008	205	0.16
		Transverse	0.011	-0.009	0.018	129	0.88
6	11.0	Vertical	0.004	-0.004	0.008	150	0.29
		Longitudinal	0.003	-0.004	0.007	156	0.23
		Transverse	0.005	-0.005	0.009	130	0.43
7	13.0	Vertical	0.008	-0.010	0.018	146	0.69
		Longitudinal	0.007	-0.008	0.015	126	0.77
		Transverse	0.010	-0.011	0.020	145	0.78
8	15.0	Vertical	0.007	-0.011	0.018	112	1.17
		Longitudinal	0.004	-0.005	0.008	206	0.15
		Transverse	0.007	-0.011	0.018	112	1.17

Note: Max = greatest instantaneous acceleration (+) direction; Min = greatest instantaneous acceleration (-) direction; P-P = greatest peak-peak acceleration.

* μ -ft = 0.000001 ft.

Table 18
Service Gallery Vibration
Series D

Test No.	Gate Opening ft	Transducer Location	Acceleration, g's			Freq Hz	Displ μ -ft*
			Max	Min	P-P		
9	1.0	Vertical	0.001	-0.001	0.002	79	0.26
		Longitudinal	0.001	-0.001	0.002	79	0.26
		Transverse	0.001	-0.001	0.002	79	0.26
8	3.0	Vertical	0.001	-0.001	0.002	79	0.26
		Longitudinal	0.001	-0.001	0.002	79	0.26
		Transverse	0.002	-0.001	0.003	145	0.12
7	5.0	Vertical	0.007	-0.055	0.062	156	2.08
		Longitudinal	0.003	-0.005	0.008	156	0.27
		Transverse	0.005	-0.007	0.012	145	0.47
6	7.0	Vertical	0.004	-0.033	0.037	185	0.88
		Longitudinal	0.003	-0.004	0.007	223	0.12
		Transverse	0.007	-0.007	0.014	128	0.70
5	9.0	Vertical	0.006	-0.035	0.041	141	1.68
		Longitudinal	0.005	-0.006	0.011	206	0.21
		Transverse	0.012	-0.011	0.023	229	0.36
4	11.0	Vertical	0.007	-0.008	0.015	152	0.53
		Longitudinal	0.006	-0.005	0.011	201	0.22
		Transverse	0.008	-0.008	0.016	130	0.77
3	13.0	Vertical	0.008	-0.012	0.017	145	0.66
		Longitudinal	0.006	-0.006	0.010	126	0.51
		Transverse	0.007	-0.008	0.014	143	0.56
2	16.0	Vertical	0.014	-0.014	0.024	169	0.69
		Longitudinal	0.008	-0.009	0.017	75	2.46
		Transverse	0.013	-0.015	0.027	168	0.78
1	15.0	Vertical	0.006	-0.023	0.026	114	1.63
		Longitudinal	0.004	-0.004	0.008	205	0.15
		Transverse	0.010	-0.012	0.022	110	1.48

Note: Max = greatest instantaneous acceleration (+) direction; Min = greatest instantaneous acceleration (-) direction; P-P = greatest peak-peak acceleration.

* μ -ft = 0.000001 ft.

Table 19
Sluice Emergency Gate Lowering Test
Series E

Span*	Item	Air Vent Discharge			Gusting Frequency cps	Feet of Water ΔP	P, psi CSC	Aerator Pressure, Feet of Water			AR6									
		Right	Center	Left				AR1	AR2	AR3		AR4	AR5							
Before	Max	2810	2663	5473	0.3	-0.95	-1.87	-2.54	-2.31	-2.56	-3.07	-2.88	-2.40							
	Mean	2206	2143	4349		-0.51								-1.10	-1.59	-1.43	-1.59	-2.19	-2.12	-1.50
	Min	1668	1691	3359		-0.21								-0.51	-0.85	-0.72	-0.88	-1.41	-1.41	-0.72
During**	Max	4383	3850	8233	0.1	-1.45	-8.40	-7.36	-6.60	-7.20	-5.98	-5.31	-6.81							
	Mean	4028	3680	7708		-0.84								-5.01	-5.40	-5.05	-5.38	-3.11	-5.21	
	Min	2716	2829	5545		-2.05								-2.05	-2.47	-2.38	-2.65	-3.05	-0.65	-2.42
After	Max	1462	1402	2864	0.1	-0.35	-0.35	-0.65	-0.51	-0.67	-1.18	-0.81	-0.55							
	Mean	1200	1150	2350		-0.08								-0.14	-0.39	-0.30	-0.46	-0.76	-0.62	-0.37
	Min	1029	966	1995		-0.03								-0.02	-0.23	-0.16	-0.23	-0.48	-0.44	-0.18

Item†	Sluice Invert Pressures, Feet of Water					Span*	Item	Structure Acceleration, g's		Vibration		Emergency Gate Acceleration, g's		Freq Hz							
	5	4	3	2	1			Max	Min	Max	Min	Max	Min		Max	Min					
Before	H	2.45	4.85	10.52	5.77	-4.25	Before	Vertical	0.011	0.020	8	0.240	-0.260	0.450							
	M	-2.86	-3.39	-5.70	0.12	-5.61									Longitudinal	-0.008	0.016	8	0.122	-0.100	0.213
	L	-8.07	-9.87	-7.13	3.73	-6.92															
	P-P	6.06	10.38	17.65	7.79	2.68															
During**	H	6.04	7.66	19.64	4.17	-5.08	During	Vertical	0.055	0.118	19	3.04	-3.06	6.10							
	M	-1.23	-2.49	7.94	-1.78	-9.62									Longitudinal	-0.058	0.178	133	1.72	-1.88	3.60
	L	-10.97	-13.08	2.68	-12.42	-15.06															
	P-P	12.69	13.84	10.96	11.25	20.14															
After	H	4.78	3.21	3.66	6.25	3.91	After	Vertical	0.008	0.015	60	0.900	-0.880	1.78							
	M	1.04	0.44	1.47	1.84	1.72									Longitudinal	-0.008	0.015	144	0.750	0.800	1.55
	L	-1.49	-1.53	-0.83	-0.35	0.38															
	P-P	6.27	4.74	4.49	6.60	4.49															

* Span - for explanation refer to Plate 24.

** Pressure transducers overanged. Values not accurate.

† H = highest instantaneous pressure; M = mean pressure; L = lowest instantaneous pressure; P-P = greatest instantaneous peak-peak pressure.

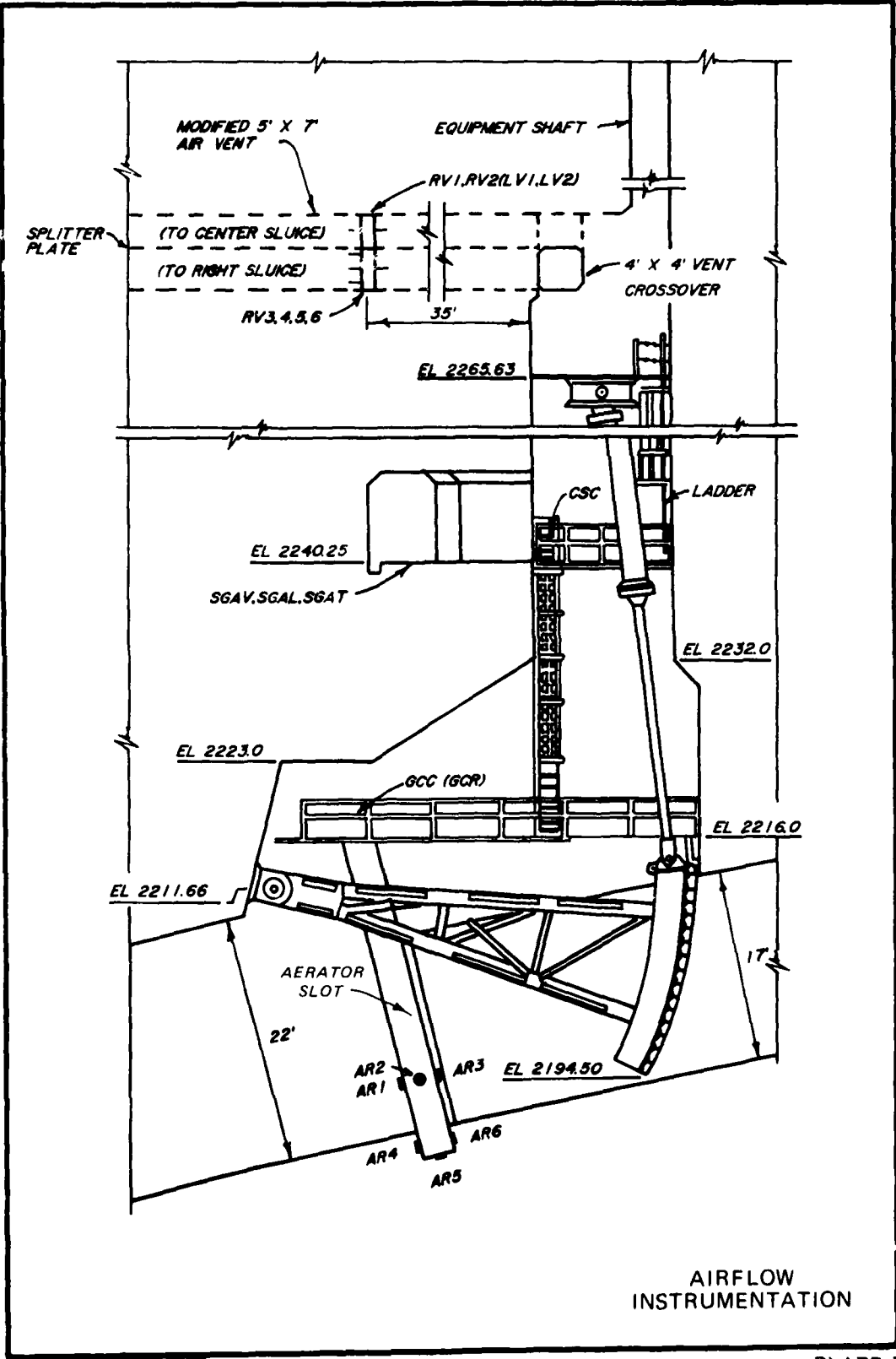

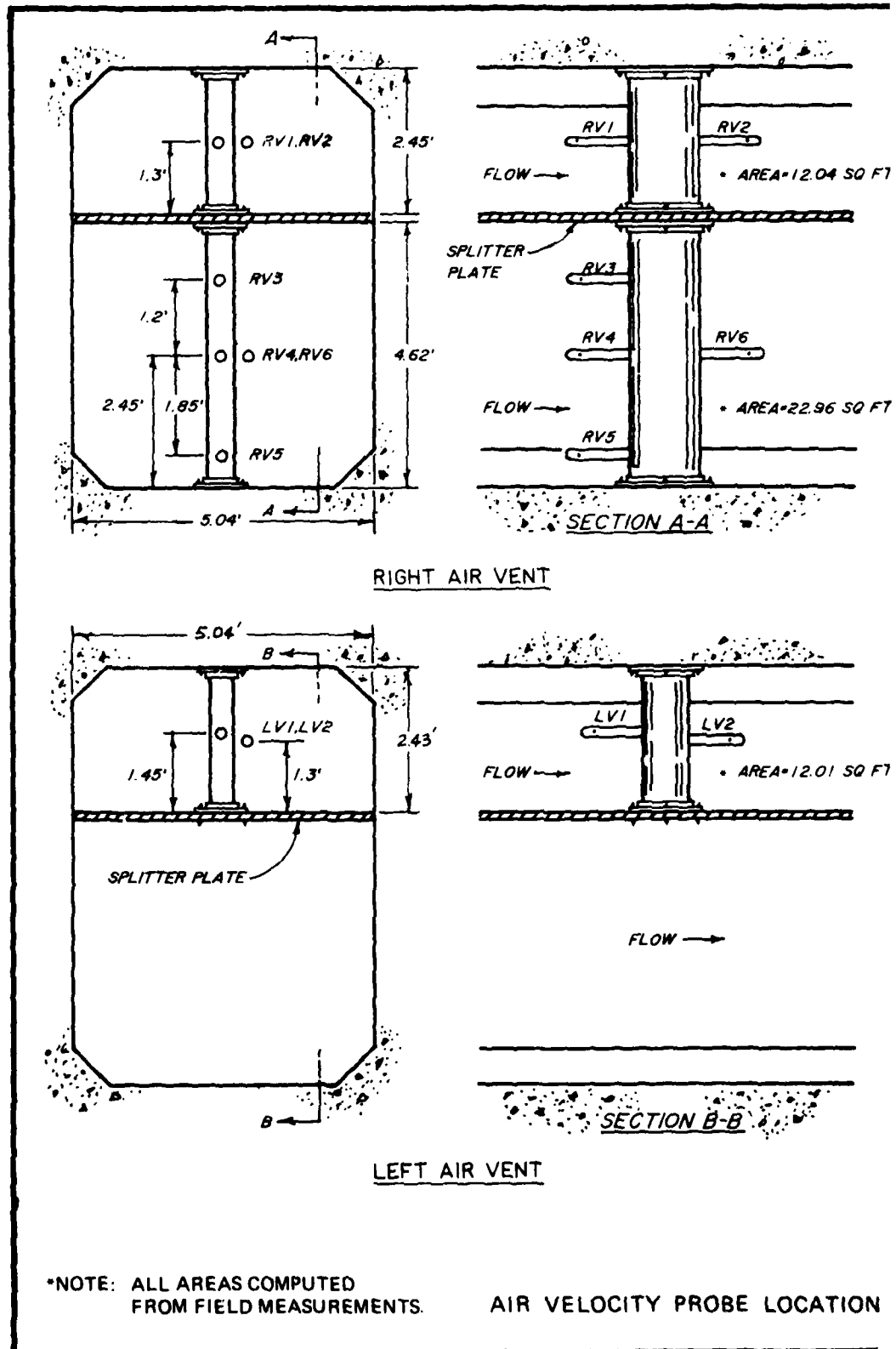
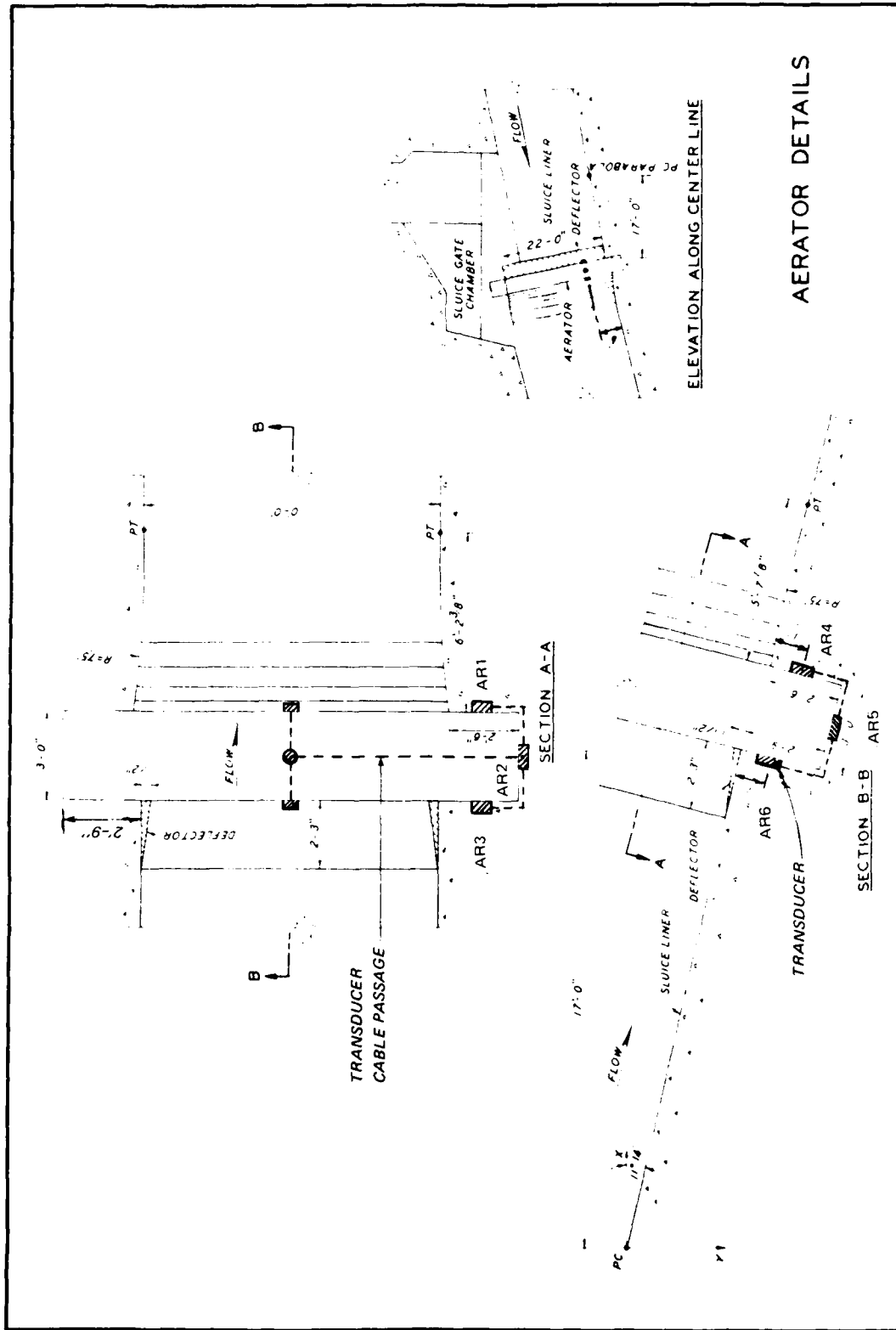

PLATE 2



AERATOR DETAILS

ELEVATION ALONG CENTER LINE

SECTION A-A

SECTION B-B

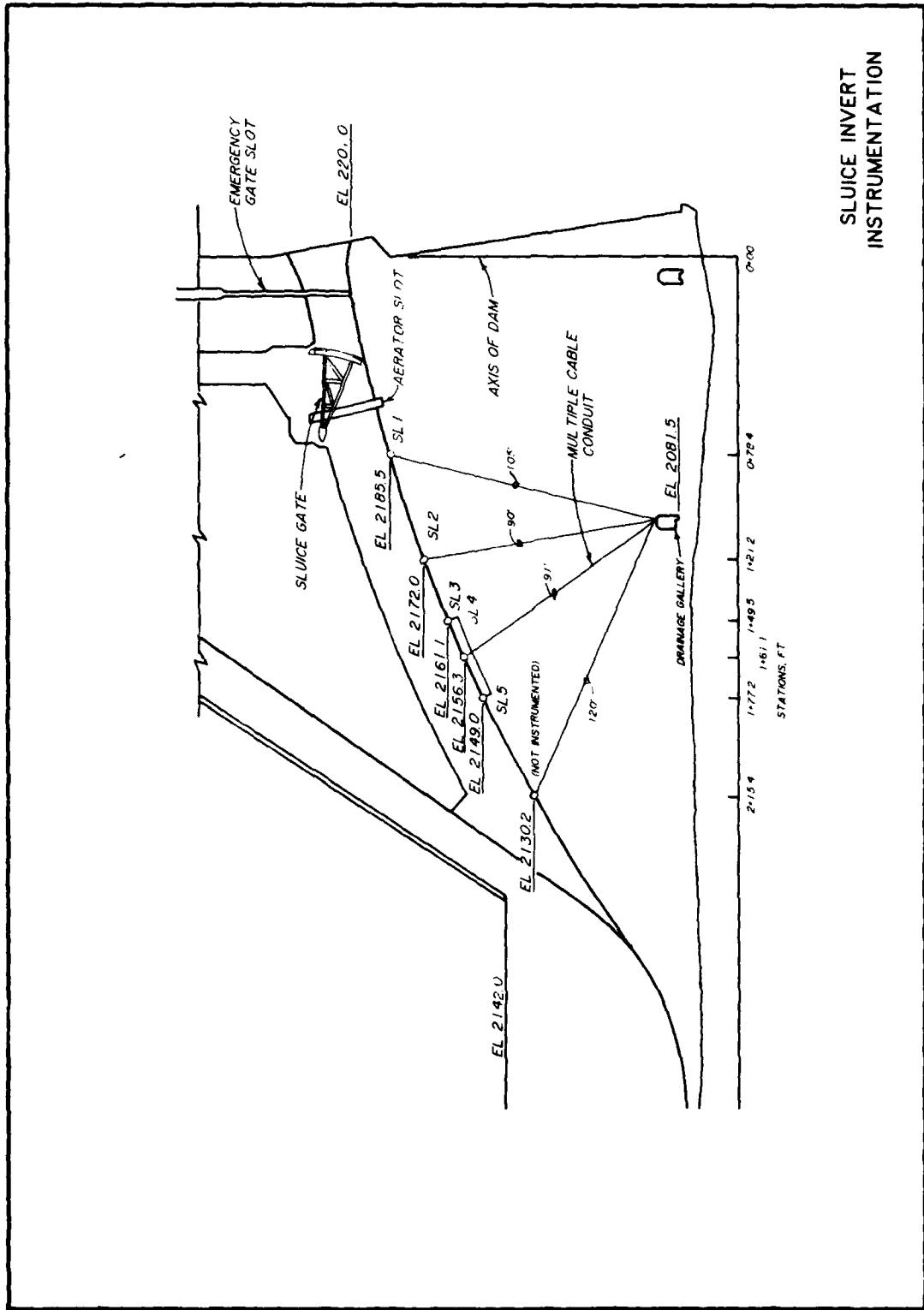

SLUICE INVERT
INSTRUMENTATION

PLATE 4

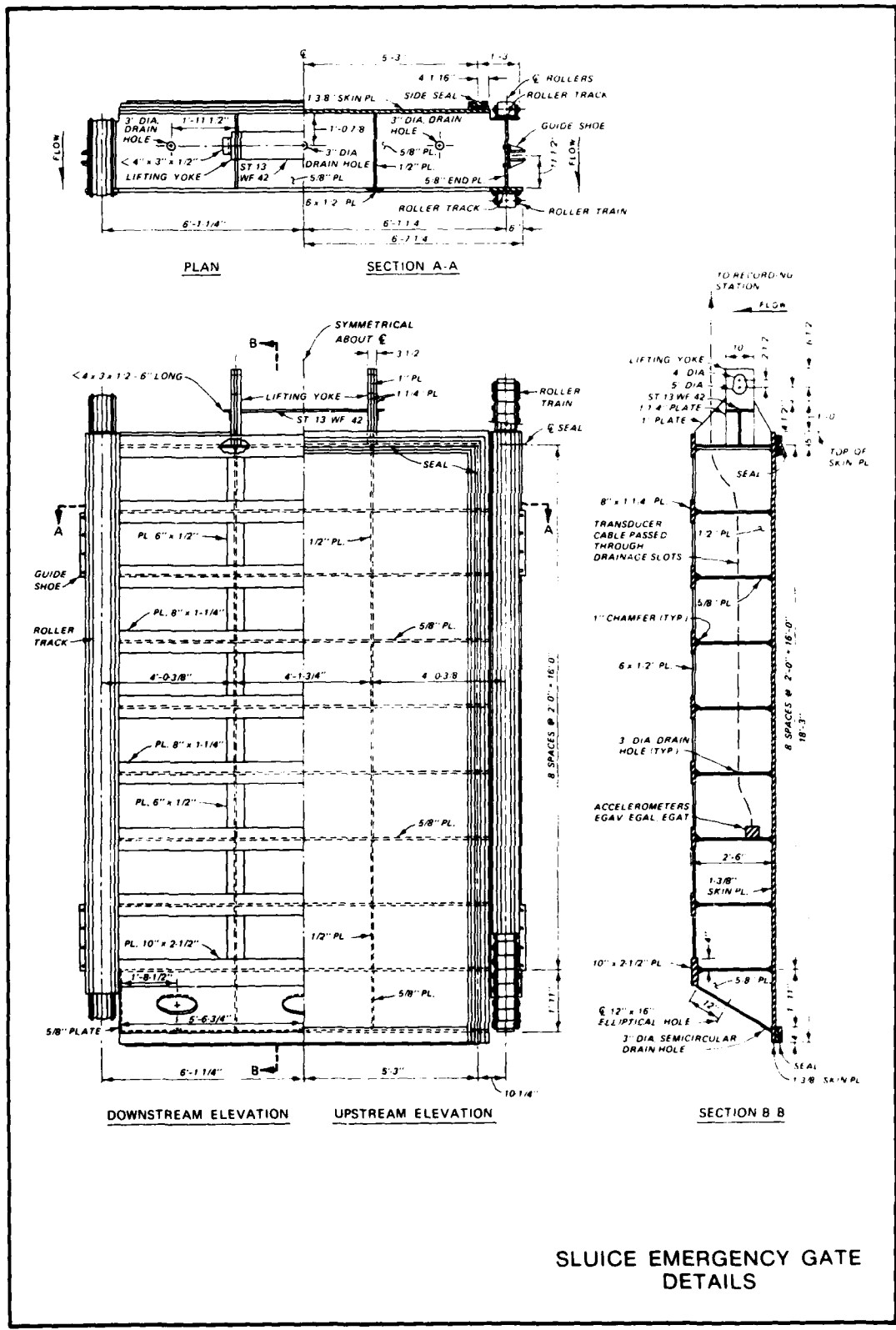

SLUICE EMERGENCY GATE
DETAILS

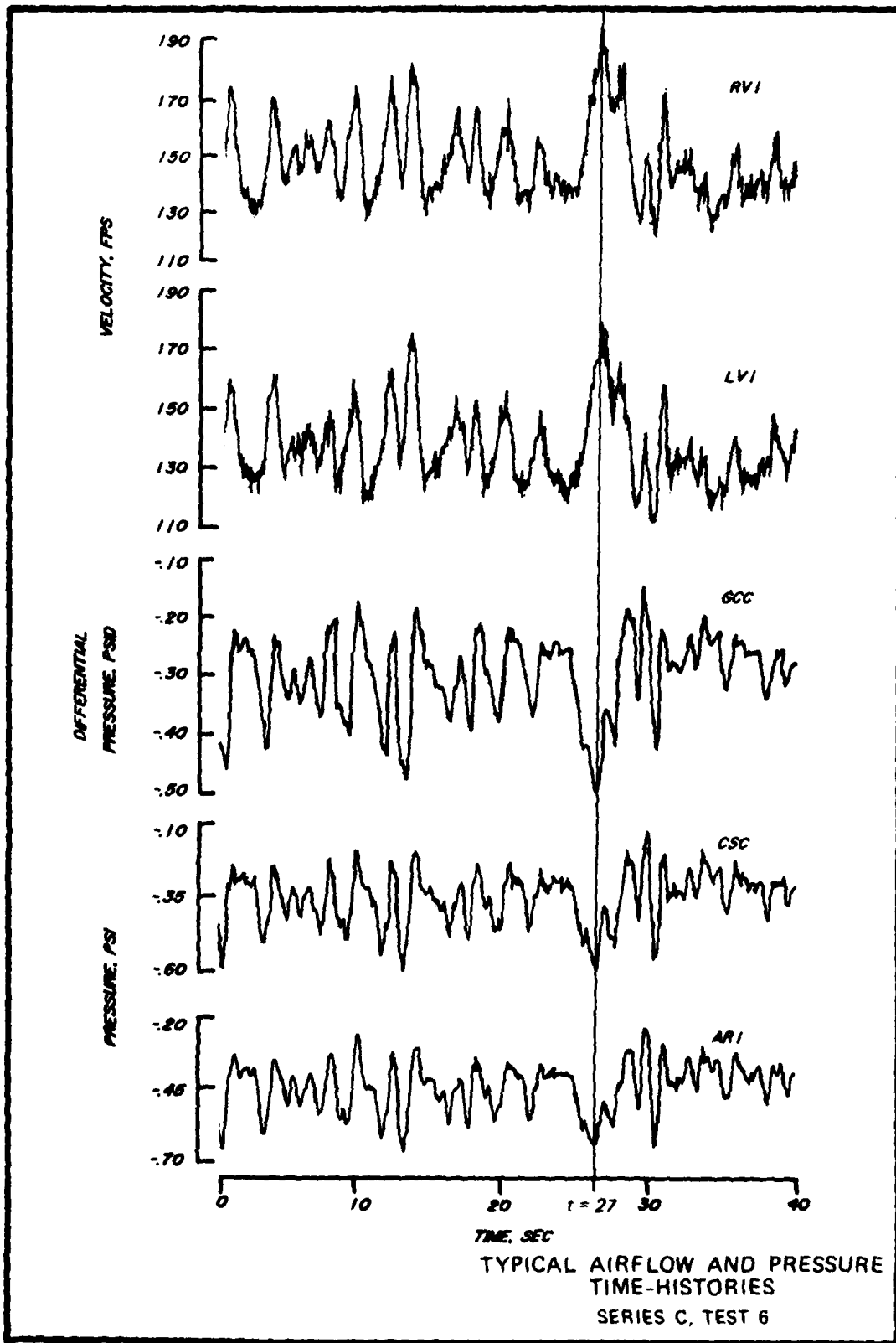

TYPICAL AIRFLOW AND PRESSURE
TIME-HISTORIES
SERIES C, TEST 6

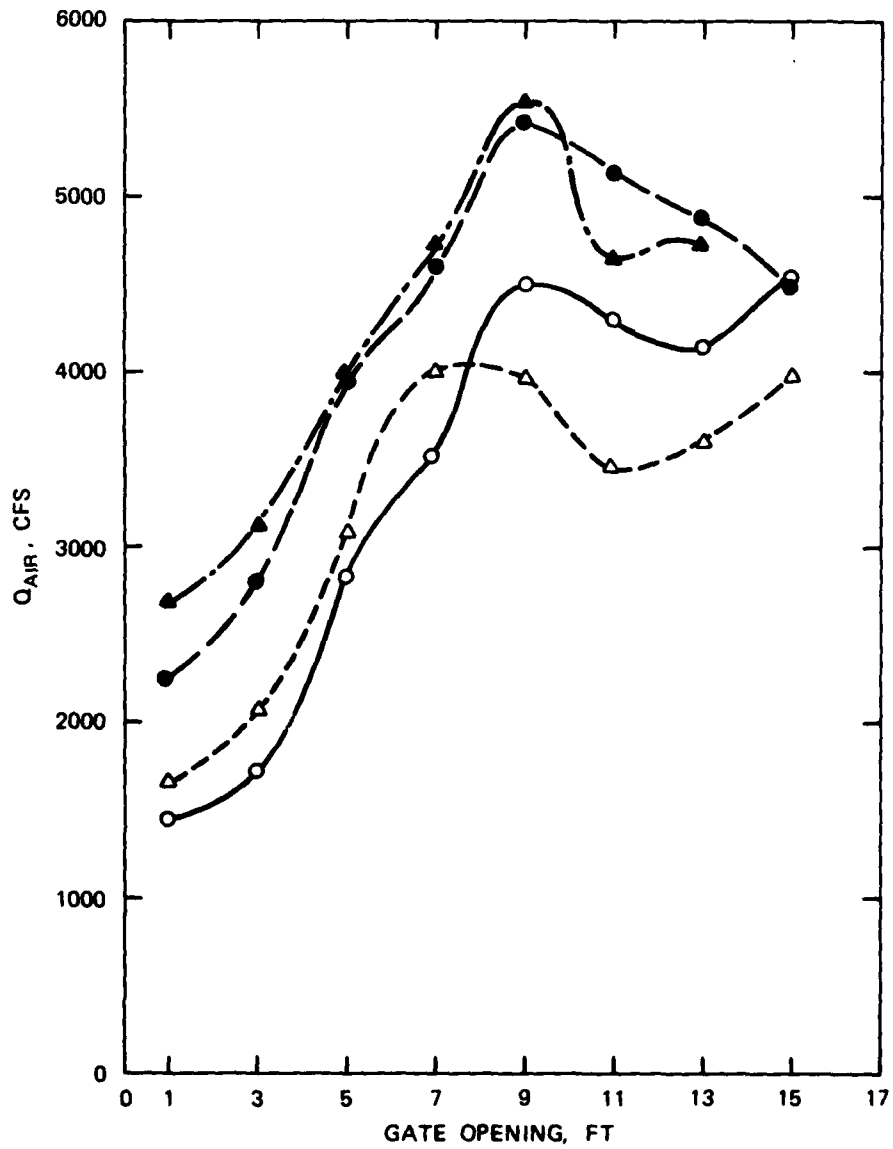

LEGEND

- SERIES A
- SERIES B
- △—△ SERIES C
- ▲—▲ SERIES D

AVERAGE AIRFLOW
VERSUS GATE OPENING
CENTER SLUICE

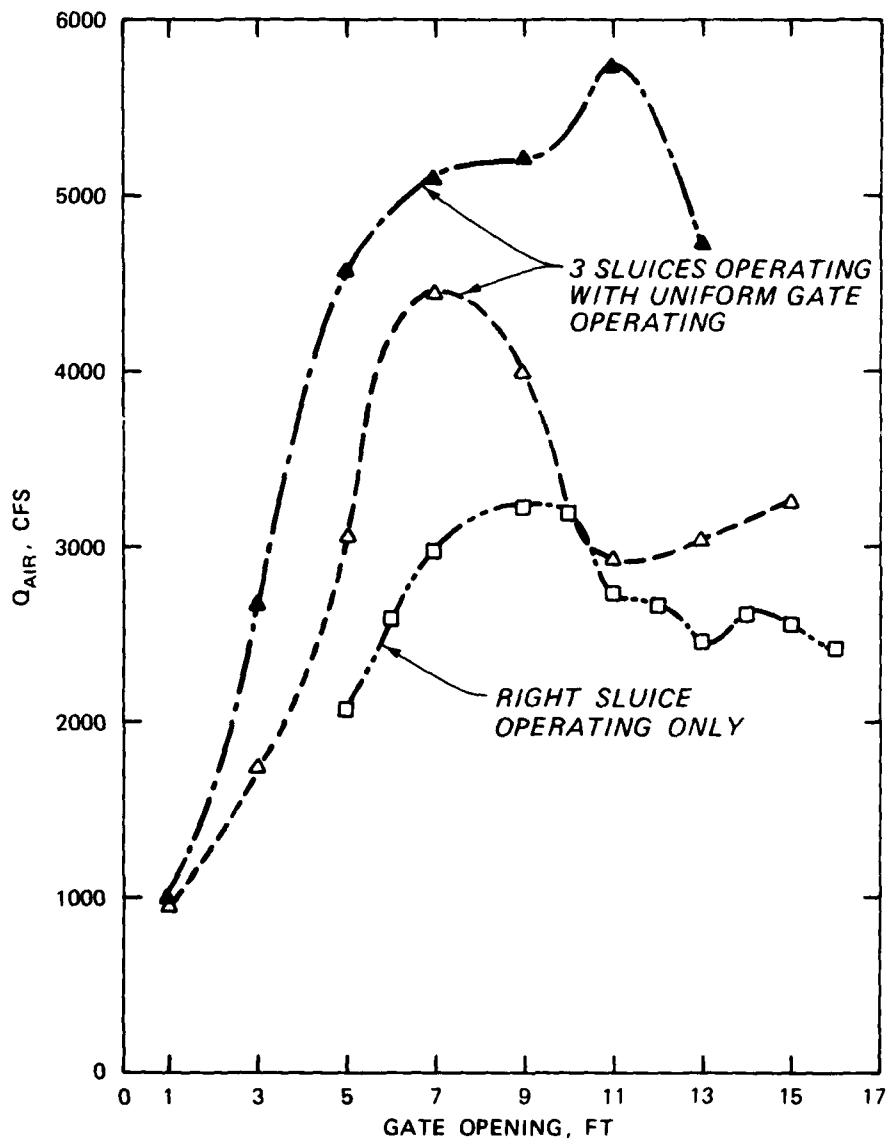

LEGEND

- △---△ SERIES C
- ▲---▲ SERIES D
- HART, 1981, RIGHT SLUICE, EQUIPMENT SHAFT CLOSED

AVERAGE AIRFLOW
VERSUS
GATE OPENING
RIGHT SLUICE

15

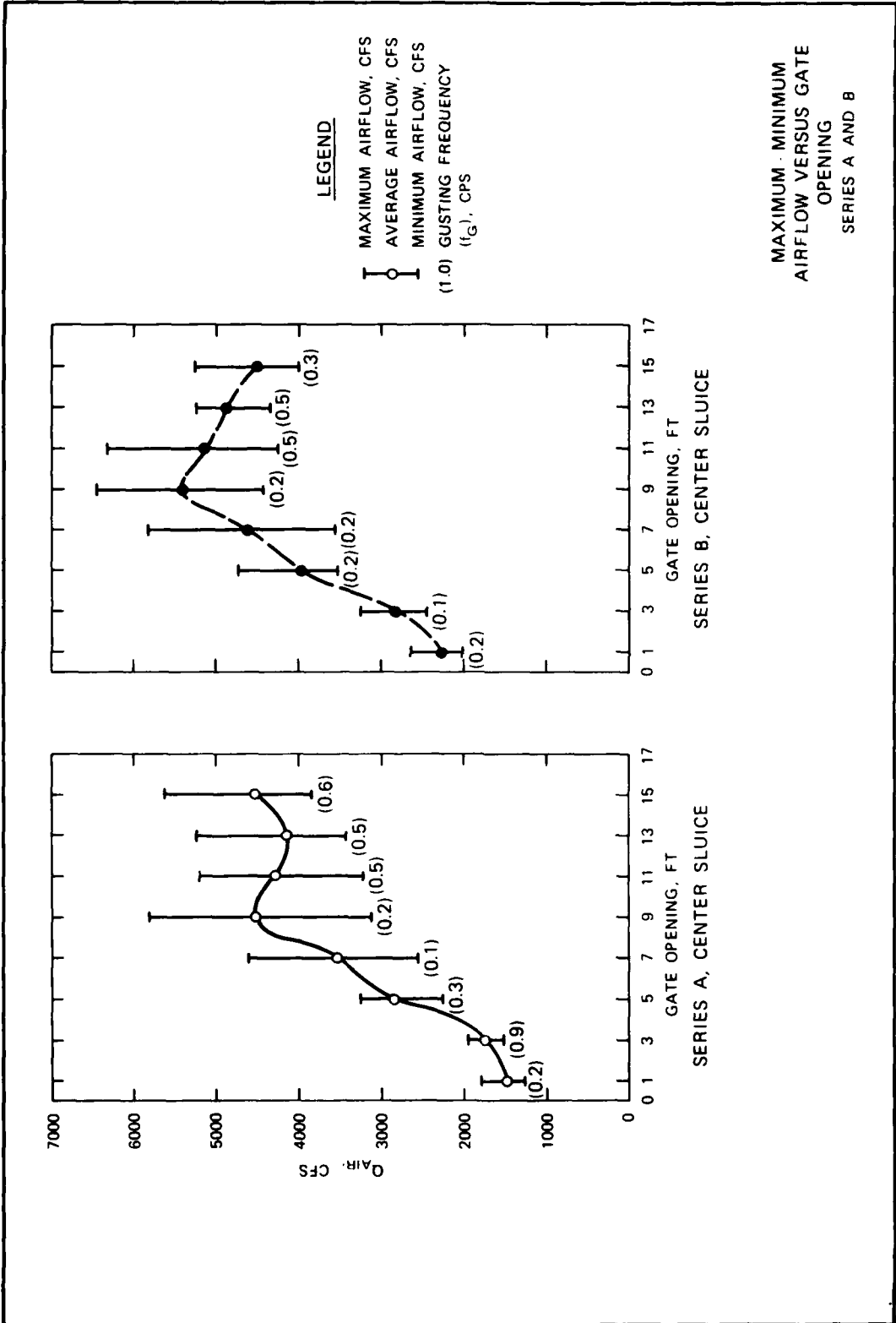

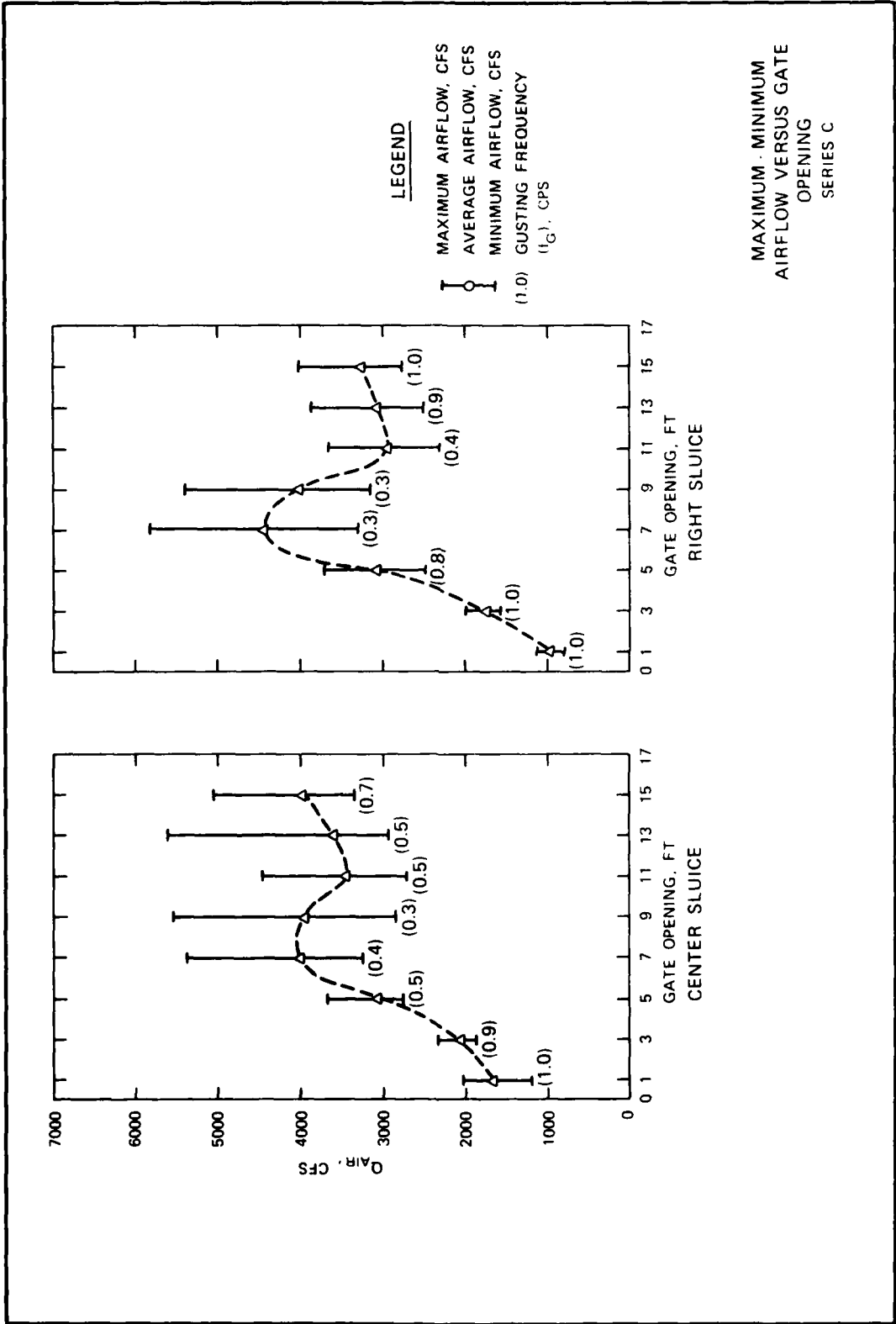
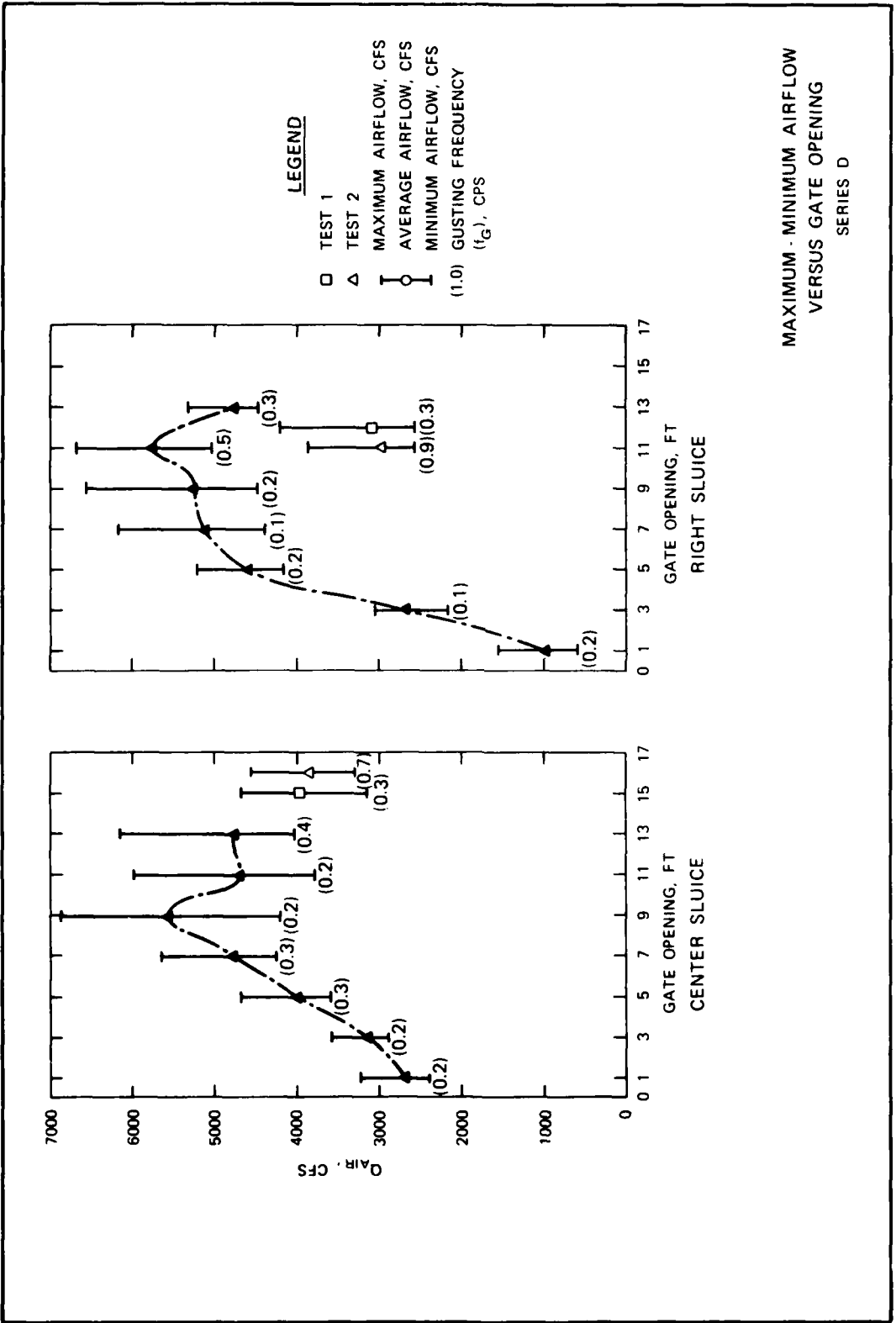
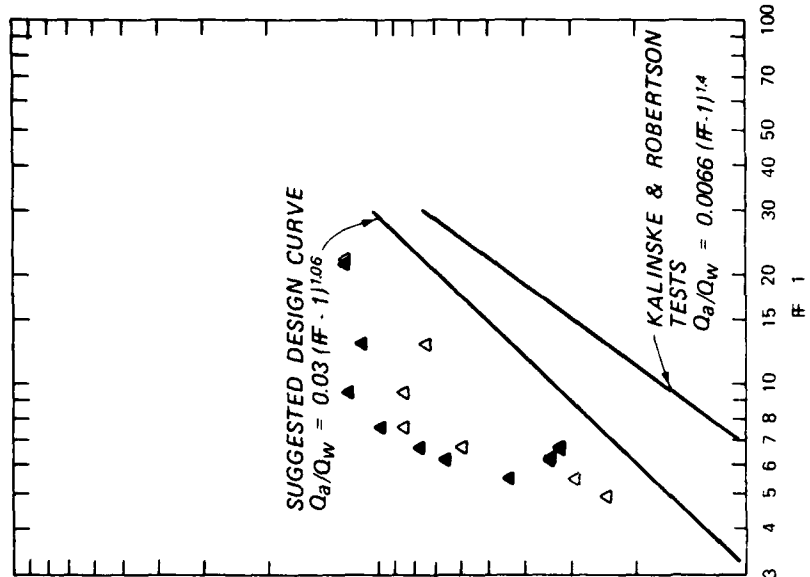

PLATE 10





RIGHT SLUICE

AIR DEMAND
FROM HDC 050.1

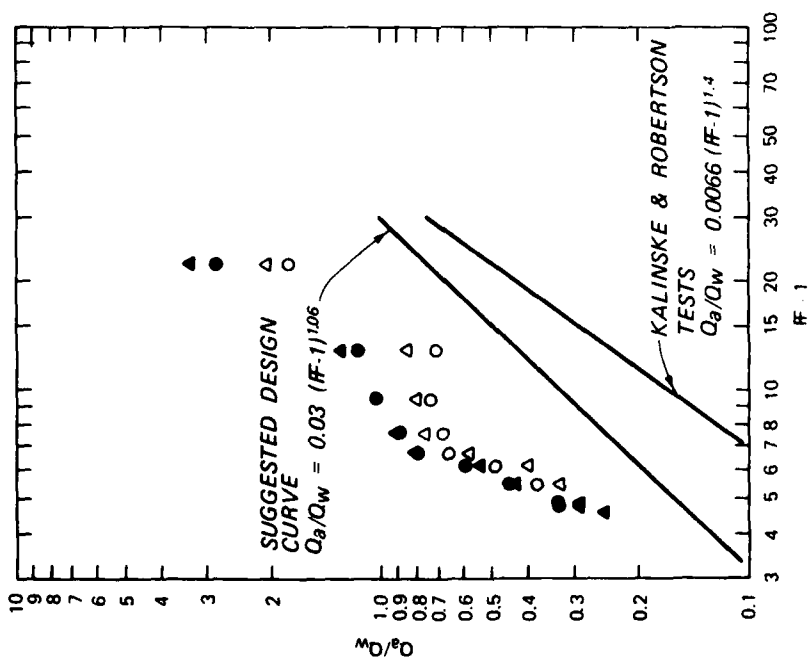

CENTER SLUICE

LEGEND

- SERIES A
- SERIES B
- △ SERIES C
- ▲ SERIES D

PLATE 12

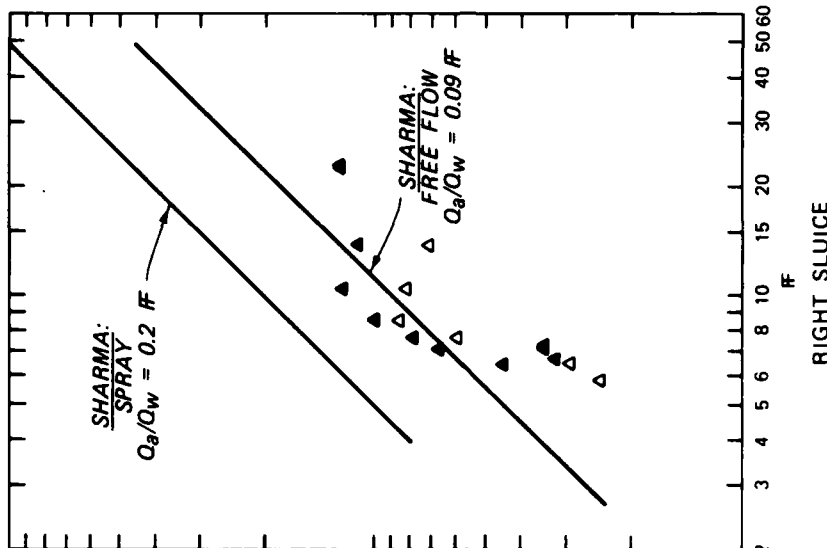
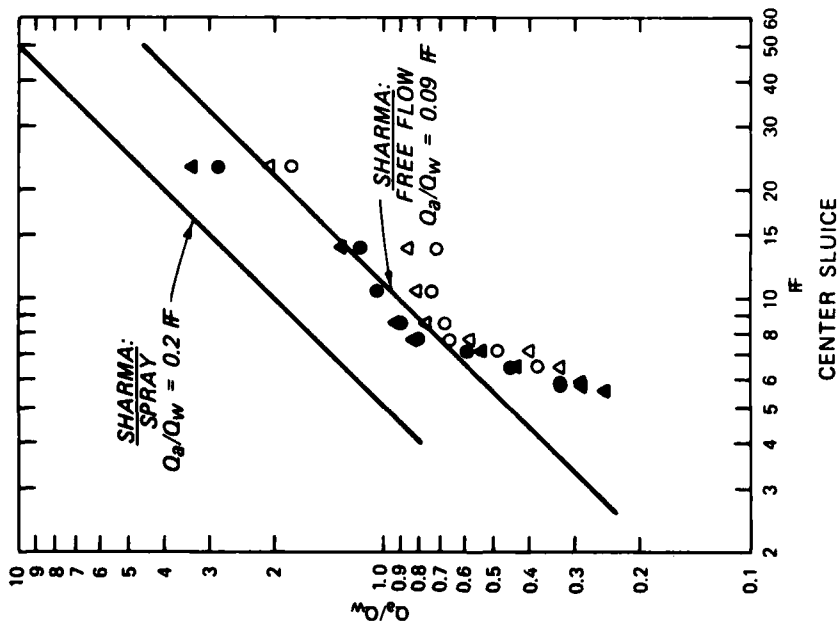

- LEGEND
- SERIES A
 - SERIES B
 - △ SERIES C
 - ▲ SERIES D

LIBBY AIRFLOW DATA AND
SHARMA'S SUGGESTED DESIGN CURVES

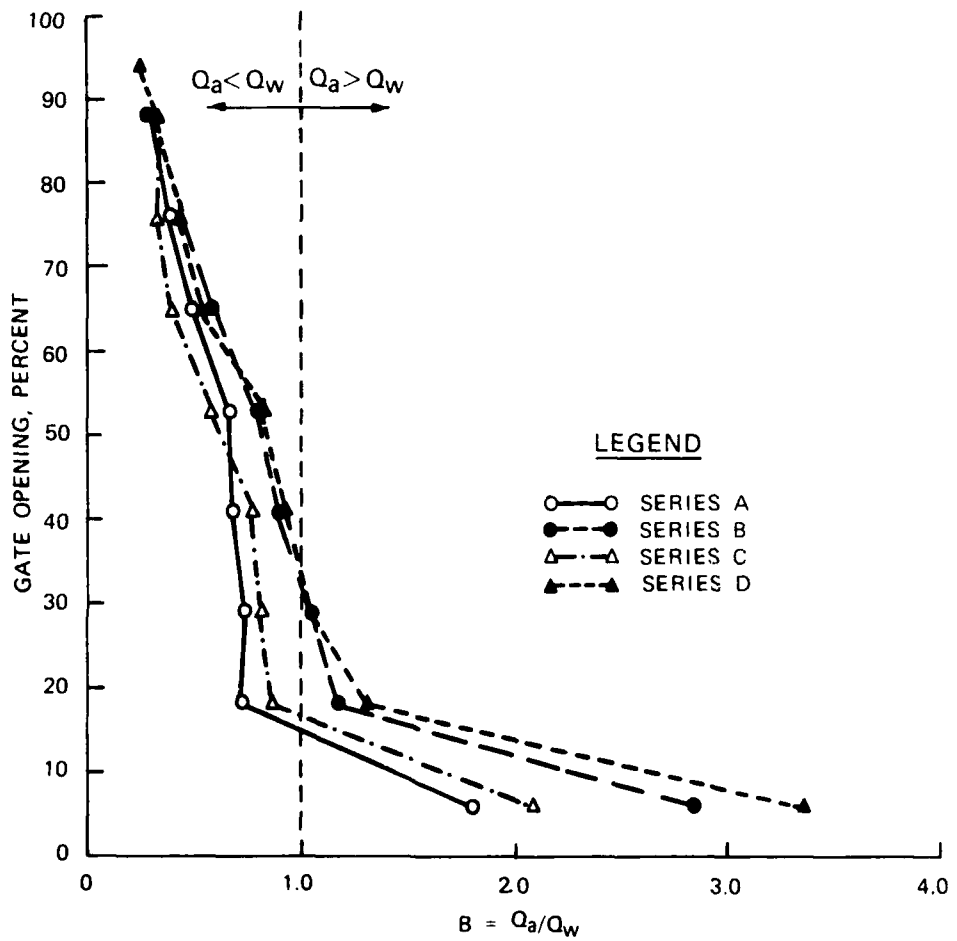

NOTE: Q_a = AIR DISCHARGE, CFS
 Q_w = WATER DISCHARGE, CFS

AVERAGE AIR-WATER
DISCHARGE RATIOS
CENTER SLUICE

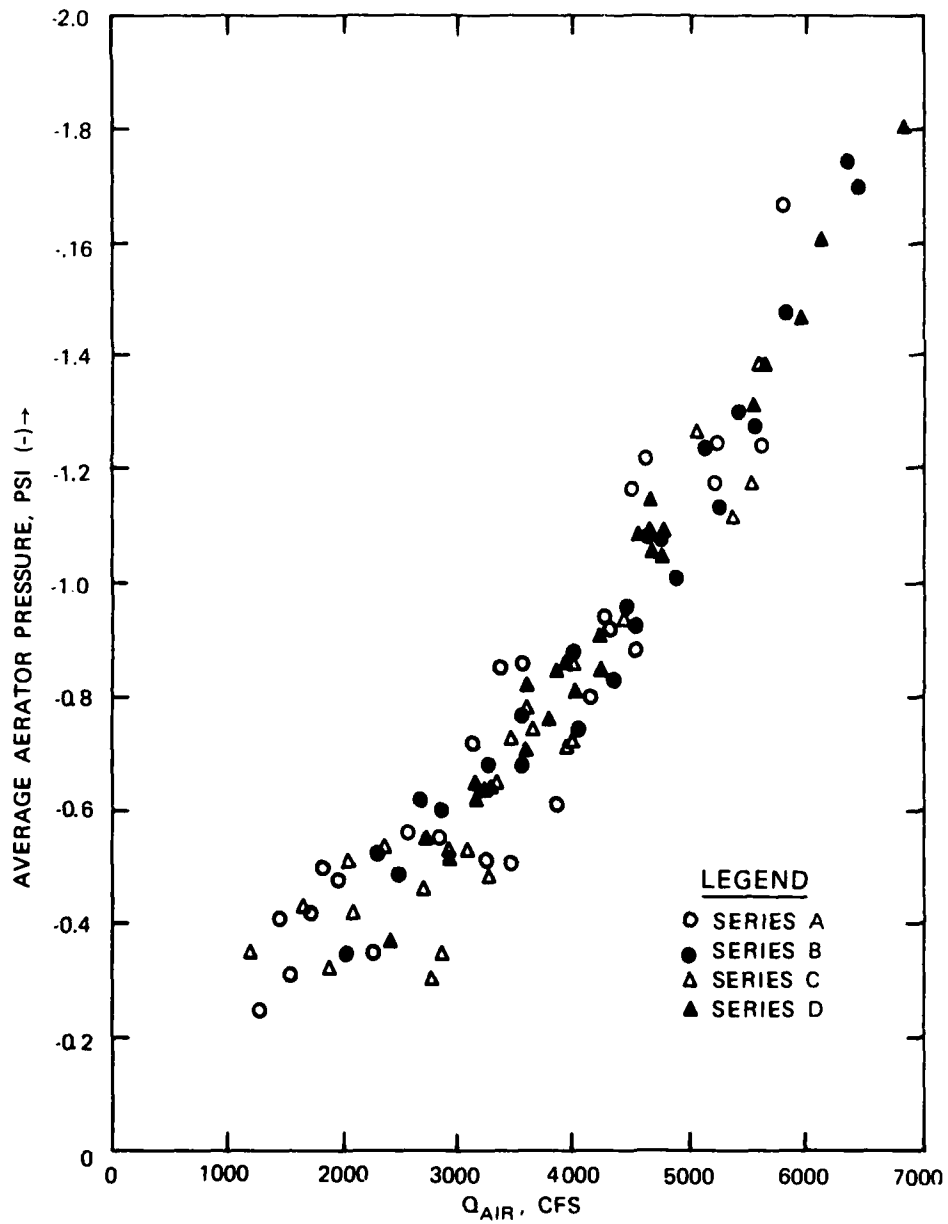

AERATOR PRESSURE (AR4) VERSUS
AIR DISCHARGE
CENTER SLUICE

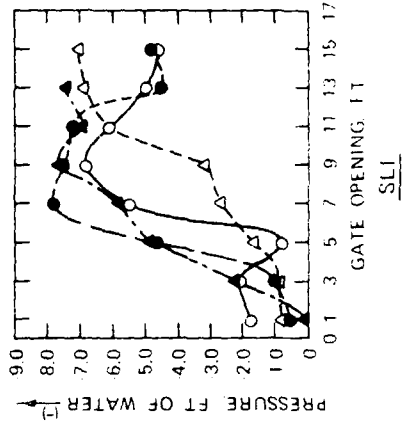
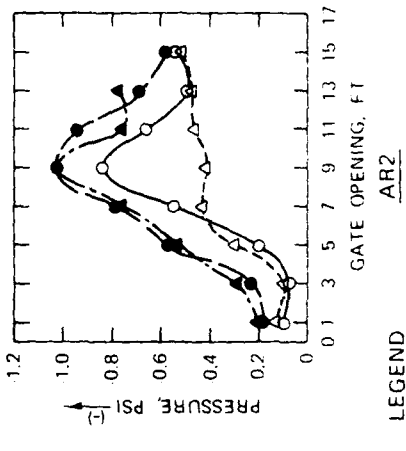
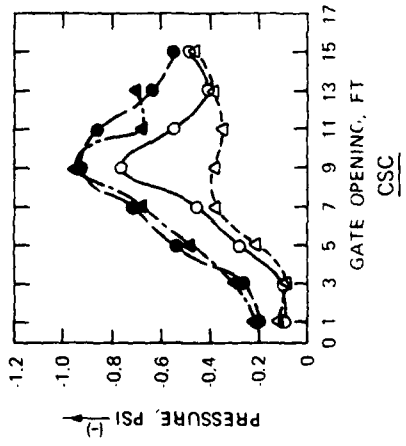
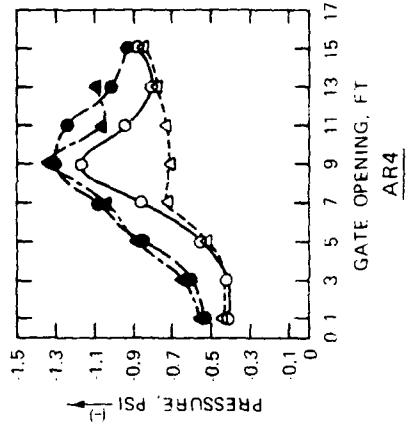
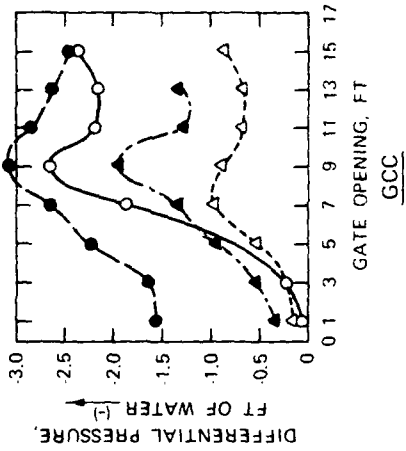
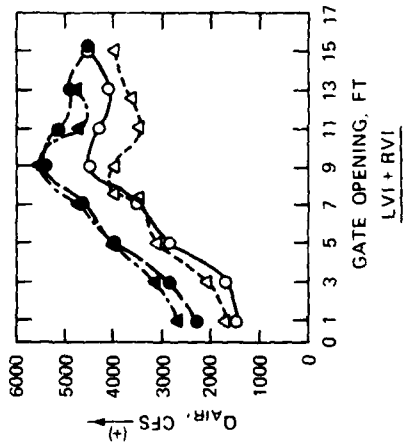

LEGEND

- SERIES A
- SERIES B
- △ SERIES C
- ▲ SERIES D

AIR DISCHARGE, PRESSURE
COMPARISON
CENTER SLUICE

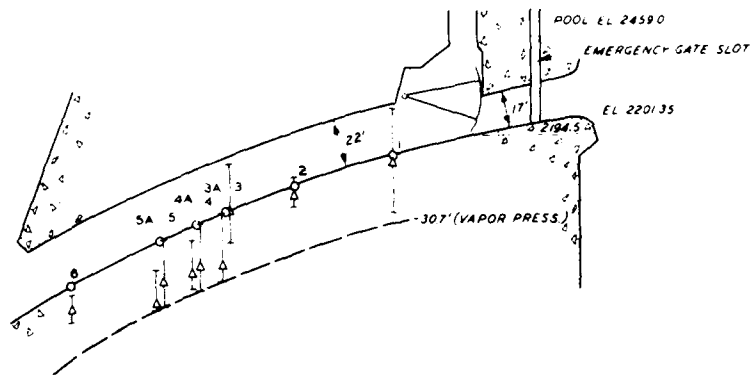

1.0-FT OPENING

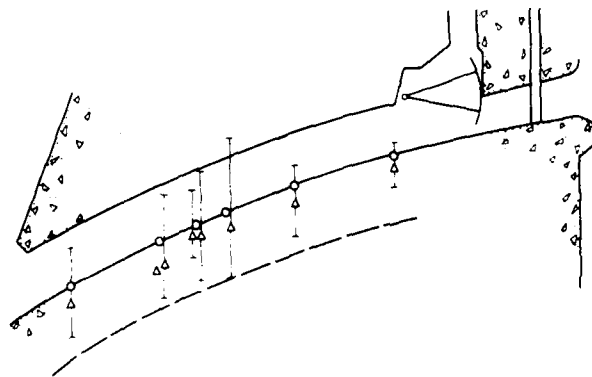

5.0-FT OPENING

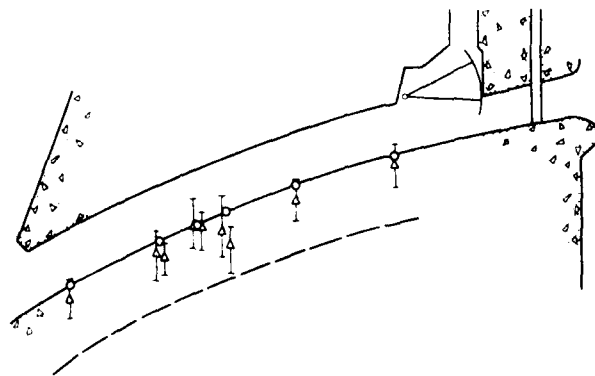

9.0-FT OPENING

- LEGEND**
- MAX PRESSURE
 - TRANSDUCER (ZERO)
 - △ AVG PRESSURE
 - MIN PRESSURE

**CENTER SLUICE PRESSURES
WITHOUT AERATOR**

1.0-, 5.0-, AND 9.0-FT GATE OPENINGS

SCALE IN FEET



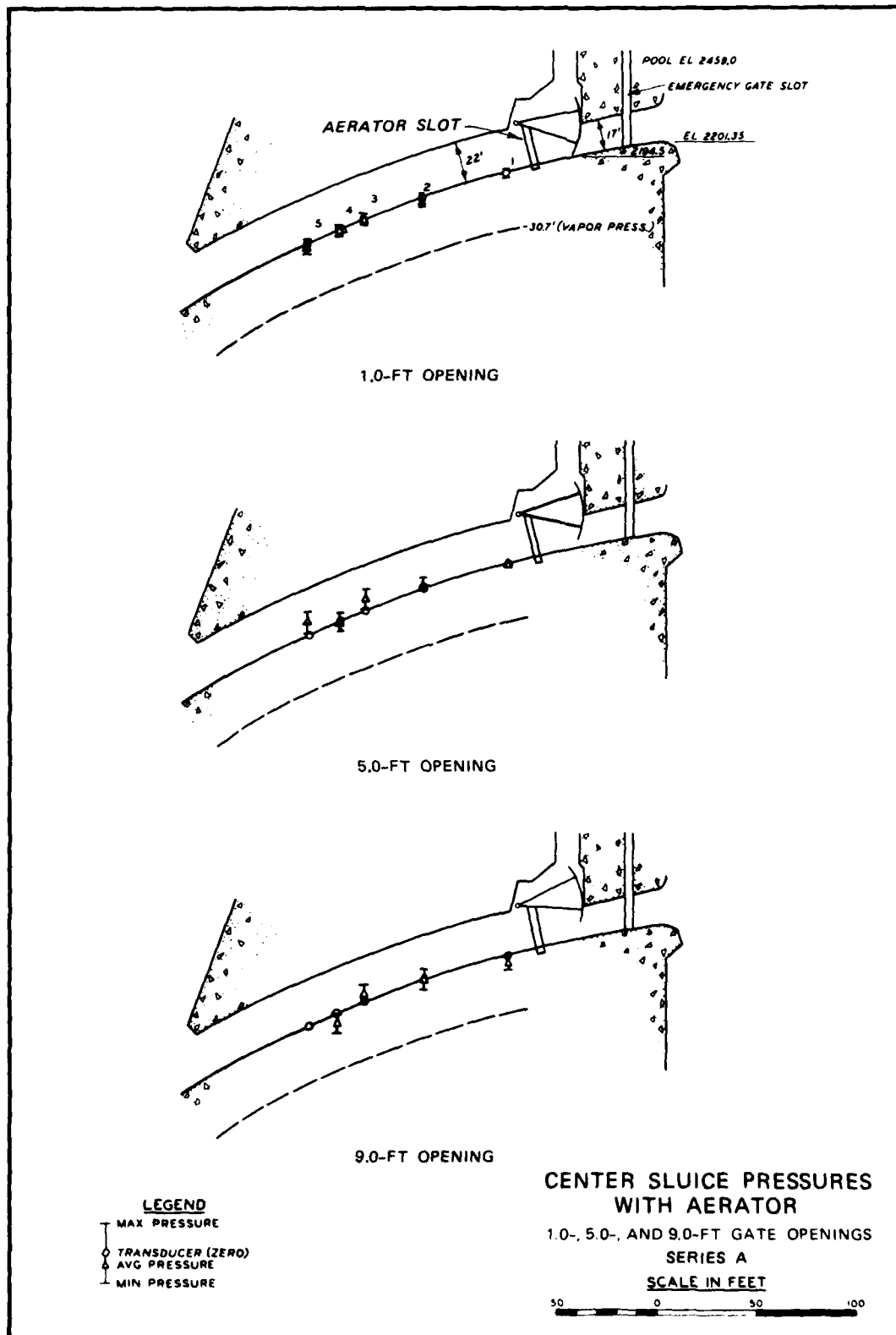
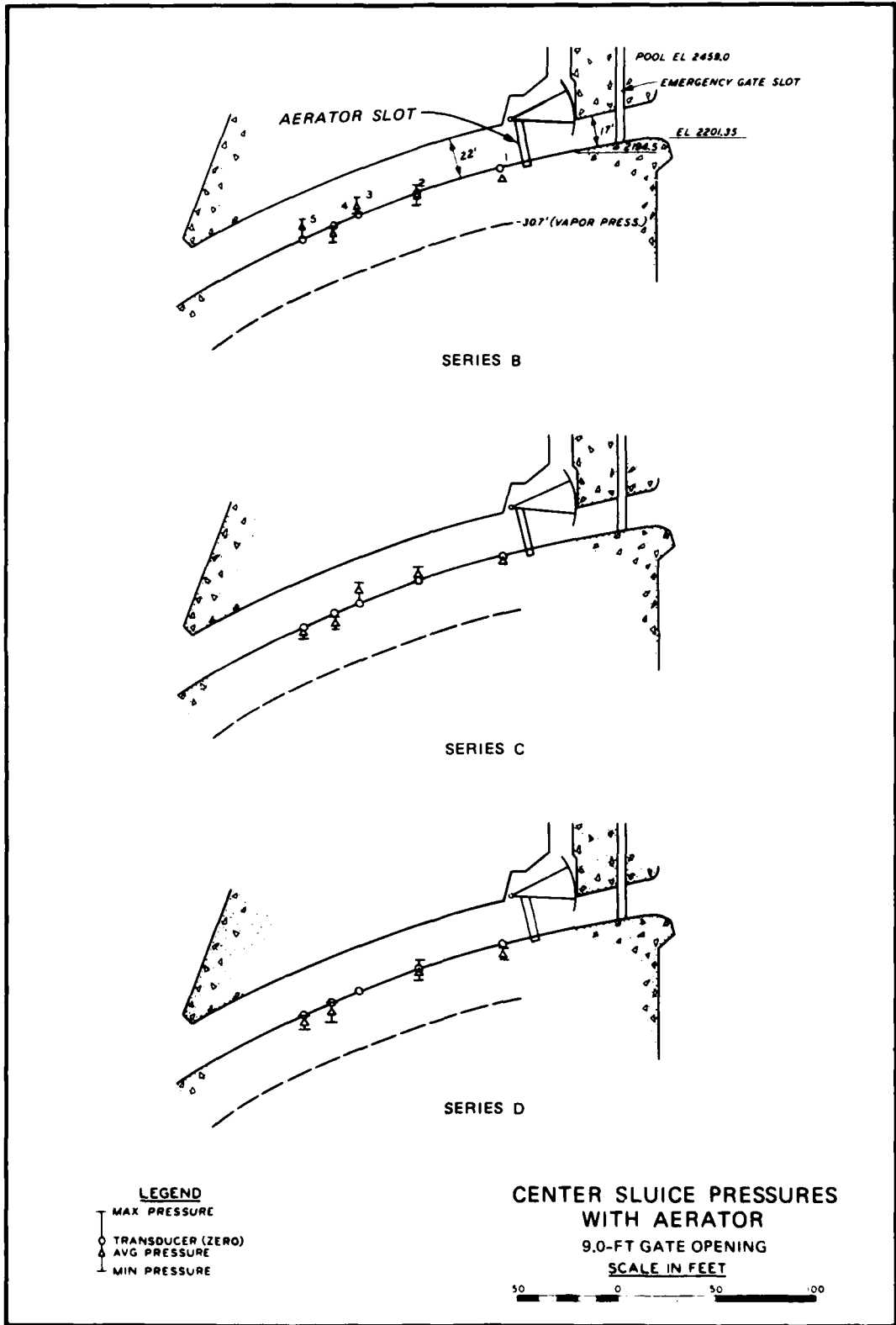
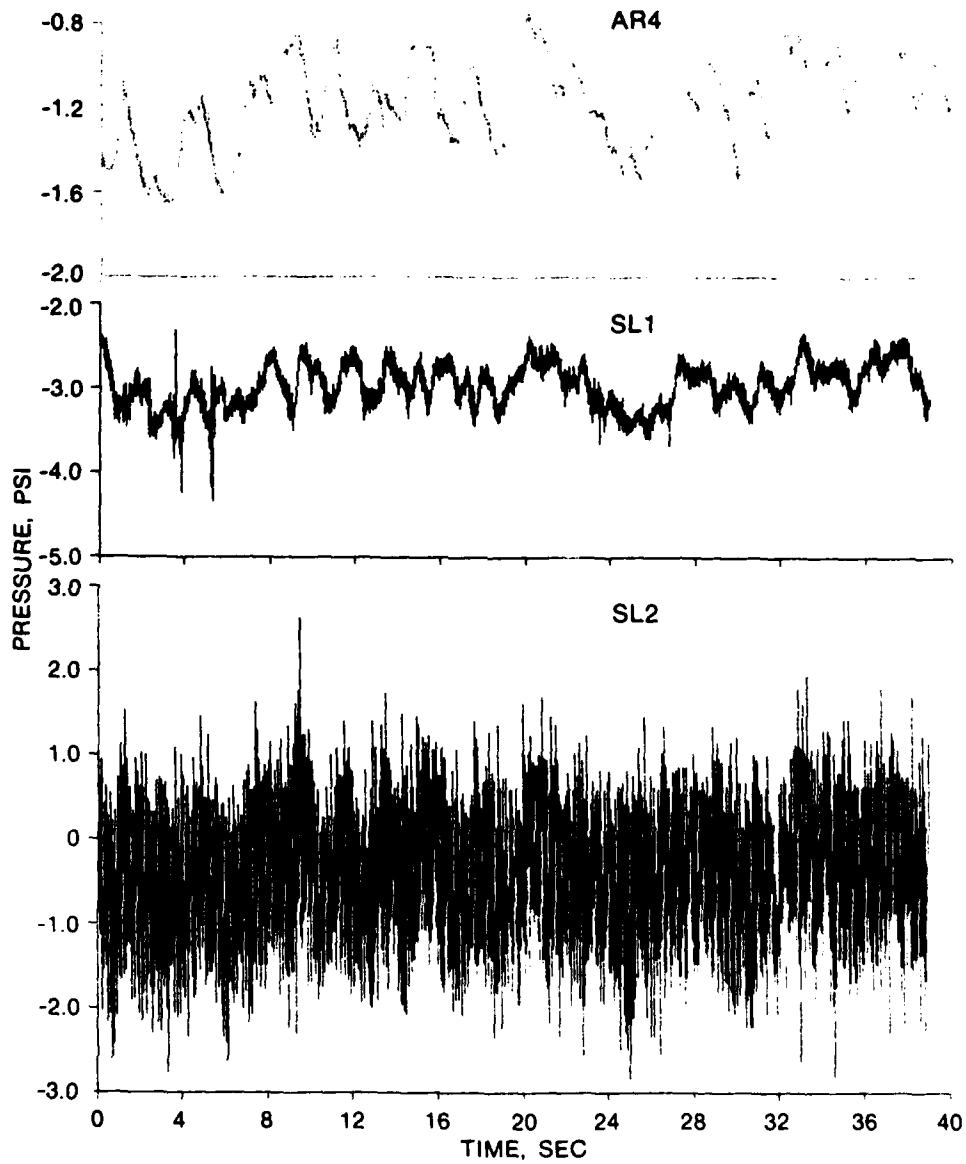
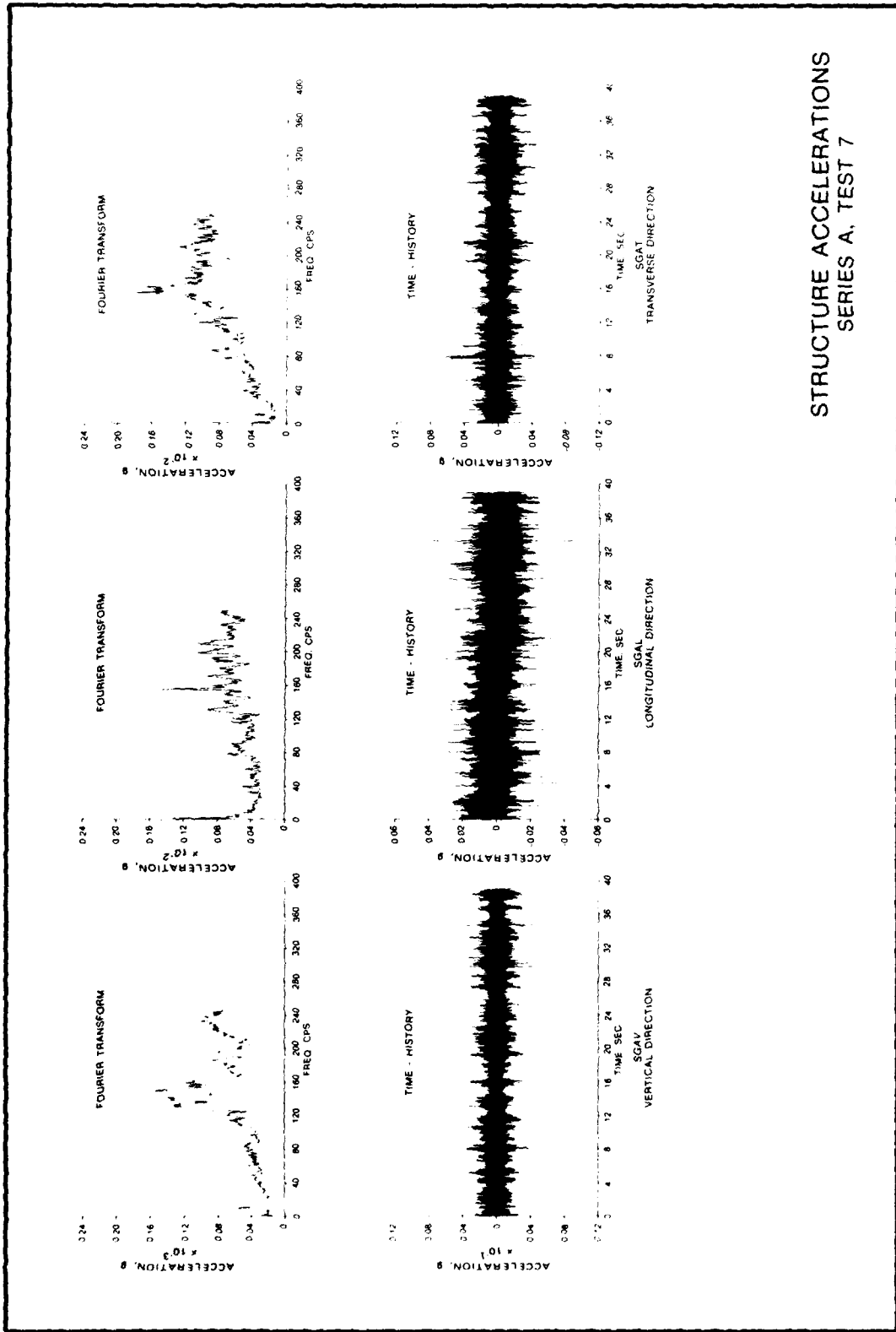

PLATE 18





TYPICAL AERATOR AND SLUICE
INVERT PRESSURE TIME-HISTORIES
CENTER SLUICE
SERIES A. TEST 6. 9.0-FT GATE OPENING



STRUCTURE ACCELERATIONS
SERIES A, TEST 7

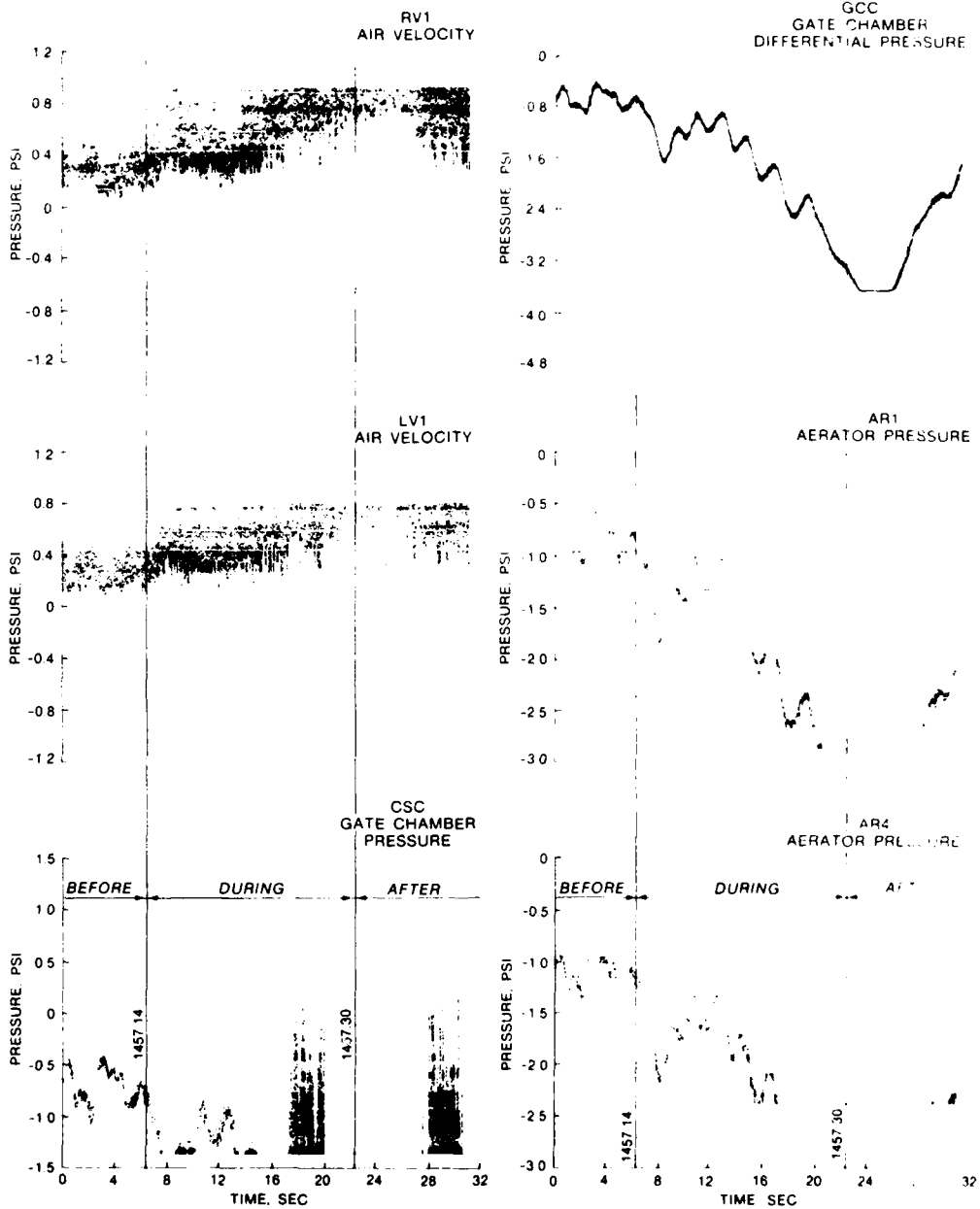

NOTE: TRANSDUCERS OVERRANGED
ON ALL TESTS.

AIRFLOW AND PRESSURE
TIME-HISTORIES
SERIES E

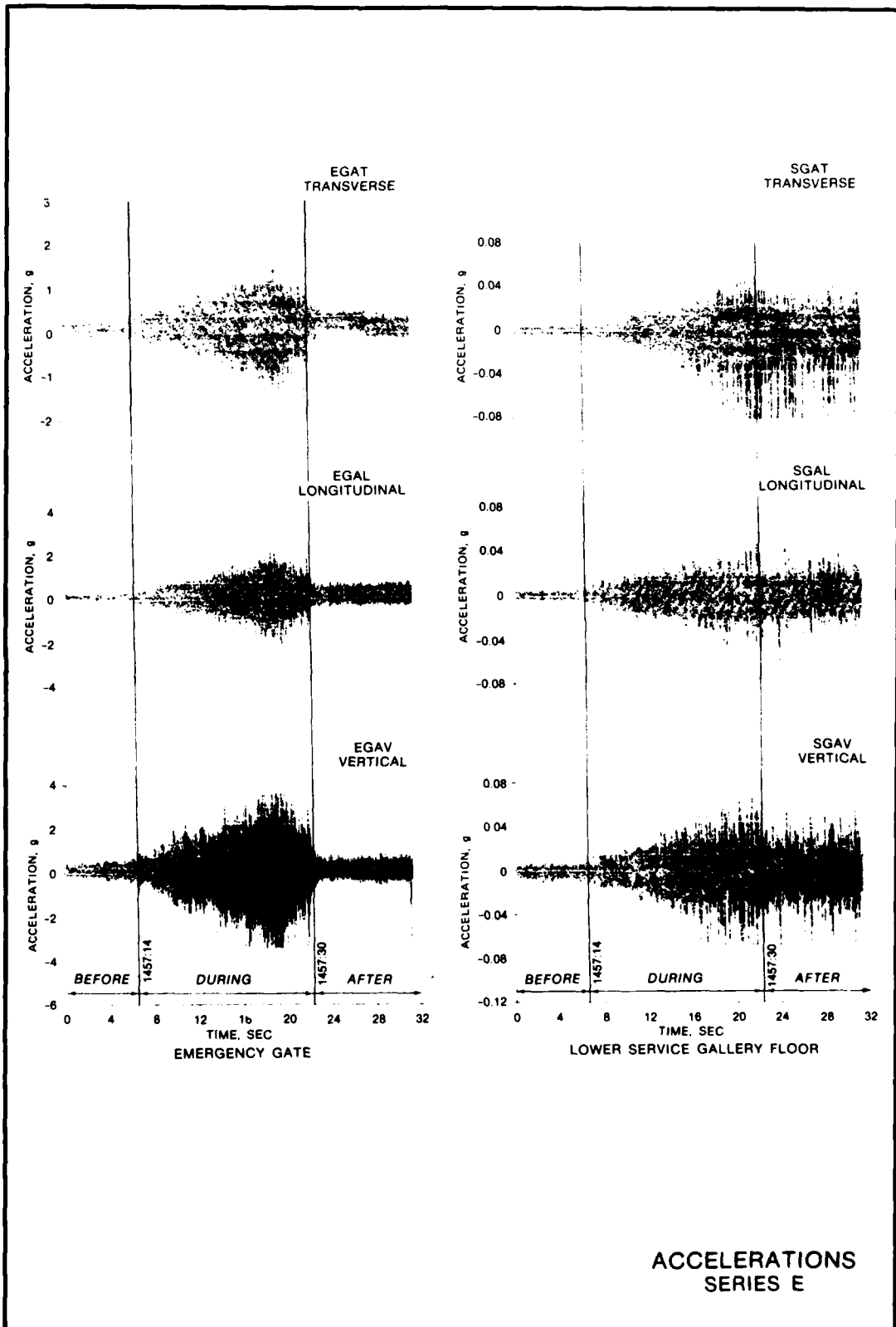

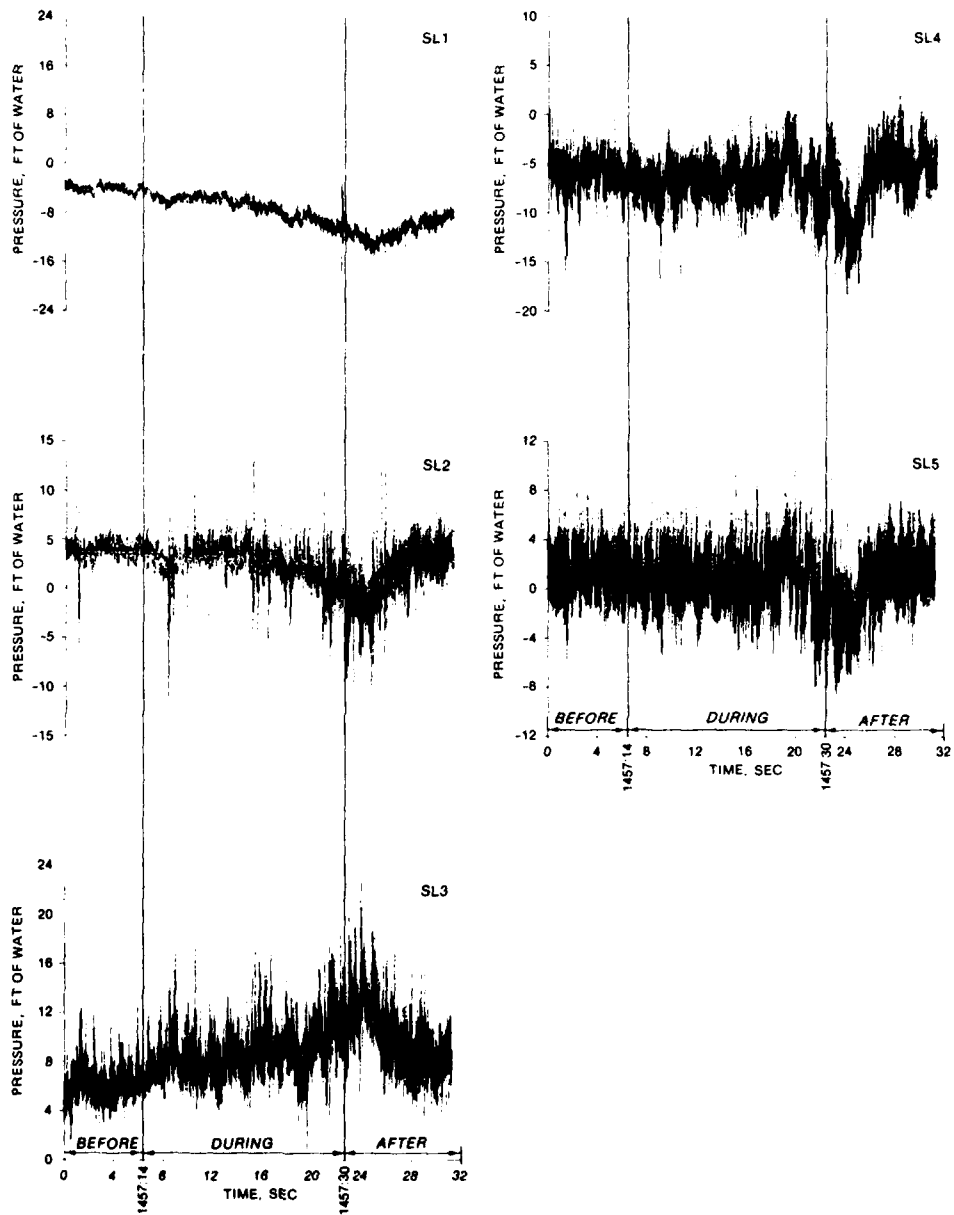

CENTER SLUICE INVERT PRESSURES
SERIES E

