

AD-A143 473

FRICION AND WEAR STUDIES OF LIQUID METAL WETTED  
METALLIC FIBER BRUSHES. (U) DAVID W TAYLOR NAVAL SHIP  
RESEARCH AND DEVELOPMENT CENTER ANN.  
N A SONDERGAARD ET AL. JUN 84

1/1

UNCLASSIFIED

F/G 11/6

NL

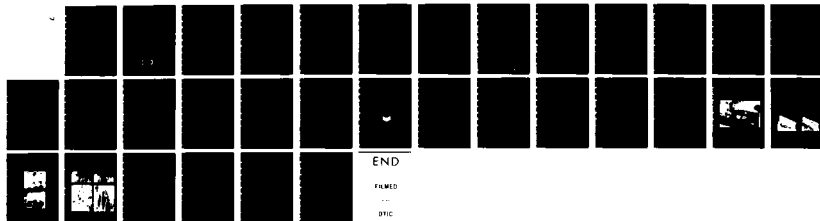

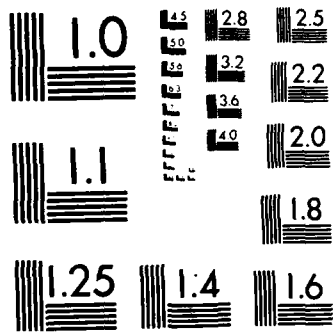

MICROCOPY RESOLUTION TEST CHART  
NATIONAL BUREAU OF STANDARDS-1963-A

12

DTNSRDC/PAS-84-12

# DAVID W. TAYLOR NAVAL SHIP RESEARCH AND DEVELOPMENT CENTER

Bethesda, Maryland 20084



AD-A143 473

FRICION AND WEAR STUDIES OF LIQUID  
METAL WETTED, METALLIC  
FIBER BRUSHES

by

N. A. Sondergaard and P. B. Clarke

APPROVED FOR PUBLIC RELEASE; DISTRIBUTION UNLIMITED

PROPULSION AND AUXILIARY SYSTEMS DEPARTMENT  
RESEARCH AND DEVELOPMENT REPORT

**S** DTIC  
ELECTE **D**  
JUL 30 1984

JUNE 1984

B

DTNSRDC/PAS-84-12

DTIC FILE COPY

FRICION AND WEAR STUDIES OF LIQUID METAL WETTED, METALLIC FIBER BRUSHES

84 07 27 091

# MAJOR DTNSRDC ORGANIZATIONAL COMPONENTS

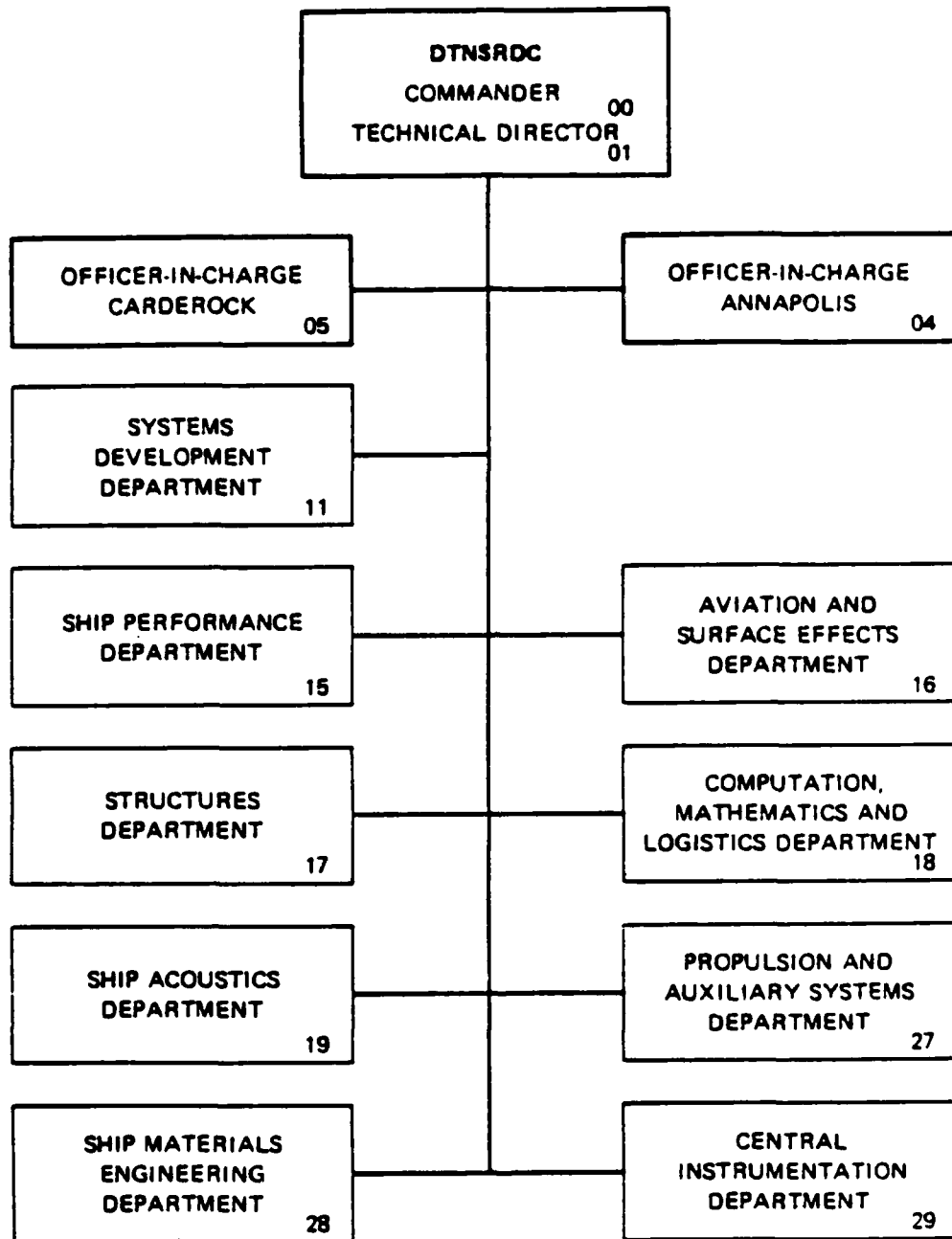

UNCLASSIFIED

SECURITY CLASSIFICATION OF THIS PAGE (When Data Entered)

REPORT DOCUMENTATION PAGE		READ INSTRUCTIONS BEFORE COMPLETING FORM
1. REPORT NUMBER PAS-84-12	2. GOVT ACCESSION NO. DA 2142-11	3. RECIPIENT'S CATALOG NUMBER
4. TITLE (and Subtitle)  FRICTION AND WEAR STUDIES OF LIQUID METAL WETTED, METALLIC FIBER BRUSHES		5. TYPE OF REPORT & PERIOD COVERED  Research and Development
7. AUTHOR(s)  Neal A. Sondergaard and Philip B. Clarke		6. PERFORMING ORG. REPORT NUMBER
9. PERFORMING ORGANIZATION NAME AND ADDRESS  David Taylor Naval Ship R&D Center Annapolis, Maryland 21402		8. CONTRACT OR GRANT NUMBER(s)
11. CONTROLLING OFFICE NAME AND ADDRESS  David Taylor Naval Ship R&D Center (Code 012.3) Bethesda, Maryland 20084		10. PROGRAM ELEMENT, PROJECT, TASK AREA & WORK UNIT NUMBERS Program Element 61152N Program No. ZR00001 Task Area ZR0240101 Work Unit 1-2712-21
14. MONITORING AGENCY NAME & ADDRESS (if different from Controlling Office)		12. REPORT DATE June 1984
		13. NUMBER OF PAGES 25
		15. SECURITY CLASS. (of this report)  UNCLASSIFIED
		15a. DECLASSIFICATION/DOWNGRADING SCHEDULE
16. DISTRIBUTION STATEMENT (of this Report)  APPROVED FOR PUBLIC RELEASE; DISTRIBUTION UNLIMITED		
17. DISTRIBUTION STATEMENT (of the abstract entered in Block 20, if different from Report)		
18. SUPPLEMENTARY NOTES		
19. KEY WORDS (Continue on reverse side if necessary and identify by block number)  Current Collectors Liquid Metals Homopolar Machines Fiber Brushes		
20. ABSTRACT (Continue on reverse side if necessary and identify by block number)  Metallic fiber brushes wetted with a liquid metal could potentially provide a current collector for large scale homopolar machinery. This study deals with the investigation of brushes composed of Niobium fibers in a copper matrix and wetted with the liquid metal, Nak78. Four brushes with different fiber diameters and packing densities have been studied. Brushes have been characterized according to stiffness and values of the coefficient of friction for both dry and Nak78 wetted brushes have been obtained. Preliminary wear		

DD FORM 1473  
1 JAN 73EDITION OF 1 NOV 65 IS OBSOLETE  
S/N 0102-LF-014-6601

UNCLASSIFIED

SECURITY CLASSIFICATION OF THIS PAGE (When Data Entered)

UNCLASSIFIED

SECURITY CLASSIFICATION OF THIS PAGE (When Data Entered)

studies indicate that if brush bounce can be avoided, lifetime should be suitable.

UNCLASSIFIED

SECURITY CLASSIFICATION OF THIS PAGE (When Data Entered)

TABLE OF CONTENTS

	PAGE
LIST OF FIGURES .....	iii
LIST OF TABLES .....	iv
LIST OF ABBREVIATIONS .....	v
ABSTRACT .....	1
ADMINISTRATIVE INFORMATION .....	1
BACKGROUND .....	1
EXPERIMENTAL WORK .....	2
Fiber Brush Fabrication .....	2
Friction .....	3
Wear .....	4
DISCUSSION .....	5
Friction .....	7
Wear .....	7
CONCLUSION .....	9
REFERENCES .....	23

LIST OF FIGURES

Figure 1 - Three Views of a DTNSRDC Braid Collector .....	11
Figure 2 - Characteristics of Niobium Fiber Brushes .....	12
Figure 3 - Method of Determining Brush Compression with Load .....	13
Figure 4 - Fiber Compression vs Load for the Four Candidate Brushes ...	14
Figure 5 - Friction Measurement Rig .....	15
Figure 6 - Friction Measurement Rig Calibration without Brush .....	16
Figure 7 - Coefficient of Friction for Four Candidate Brushes .....	17
Figure 8 - 19 m/sec Wear Apparatus .....	18
Figure 9 - Wear After 900 Hour Run .....	19
Figure 10 - "B" Brush, No NaK 40 Hour Run .....	20
Figure 11 - Brushes A and D After 100 Hour Bounce Free Wear Run .....	21
Figure 12 - Cantilever Strut Model of Fiber Brush .....	22

LIST OF TABLES

	PAGE
Table 1 - Predicted and Measured Stiffness for Four Candidate Brushes....	8

LIST OF ABBREVIATIONS

AL	aluminum
B	flexual rigidity
Cu	copper
E	elastic modulus
g	grams
g/mil	gram/milli inch
in <sup>2</sup>	square inches
I	moment of inertia of cylinder
L	undeflected length of fiber
kW	kilowatt
MA/m <sup>2</sup>	current density
mils/g	milli inches/gram
m/sec	meter/sec
mm	millimeter
m <sup>2</sup>	square meter
μ	coefficient of friction
m	micro meter
Nak <sub>78</sub>	eutectic mixture of sodium potassium
Nb	Niobium
Nt	Newton
r	force on fiber tip
sec	seconds
RAD	radius
T	tesla
θ <sub>0</sub>	angle fiber makes with Normal before deflection
x <sub>1</sub>	X coordinate of deflected fiber
y <sub>1</sub>	Y coordinate of deflected fiber



Accession For	
NTIS GRA&I	<input checked="" type="checkbox"/>
DTIC TAB	<input type="checkbox"/>
Unannounced	<input type="checkbox"/>
Justification	
By _____	
Distribution/	
Availability Codes	
Dist	Avail and/or Special
A-1	

## ABSTRACT

Metallic fiber brushes wetted with a liquid metal could potentially provide a current collector for large scale homopolar machinery. This study deals with the investigation of brushes composed of Niobium fibers in a copper matrix and wetted with the liquid metal, Nak<sub>78</sub>. Four brushes with different fiber diameters and packing densities have been studied. Brushes have been characterized according to stiffness and values of the coefficient of friction for both dry and Nak<sub>78</sub> wetted brushes have been obtained. Preliminary wear studies indicate that if brush bounce can be avoided, lifetime should be suitable.

## ADMINISTRATIVE INFORMATION

This work was performed under the Fiber Brush Current Collector Program, Task Area ZF66-512-001 sponsored by Independent Research Program, Dr. David Moran, 0120. This work was accomplished under Work Unit Number 1-2710-121-10 in the Electrical Machinery Technology Branch, Electrical Systems Division of the Propulsion and Auxiliary Systems Department of the Center.

## BACKGROUND

The development of low loss, high performance current collectors has been an objective of the Navy's advanced electric drive technology program for the past decade. With such collectors the implementation of very high performance acyclic electric machinery is feasible.<sup>1</sup>

The requirements of low power losses at current densities of 8 MA/m<sup>2</sup> and tip velocities of 15 m/sec eliminate from consideration conventional carbon brush technology. In addition, a successful collector must operate in magnetic fields of 1.5T and have sufficiently low wear as not to be a dominating factor in shipboard maintainability.

Progress has been made in achieving such a collector for laboratory scale (300 kW) electric machinery.<sup>2,3</sup> These collectors are realized by filling the space between the rotating and stationary members in the region of the collector with a liquid metal which makes the electric contact. A practical, further requirement of the collector is that the gap distance between rotor and stator be minimized. This is achieved in the aforementioned collector, by

also inserting a copper braid in the same channel as the liquid metal. On assembly, there is an interference fit between the rotor and the braid which wears to minimum clearance. A diagram of the collector geometry is shown in Figure 1. In addition to providing a mechanism for minimum clearance, the braid presumably wicks the liquid metal, holding it in place against hydrodynamic and electromagnetic expulsion forces.

When one considers possible collectors for 30 Megawatt shipboard machinery, several potential drawbacks to braid collectors can be noted. Firstly, with bearing runout and rotor sag there may be as much as a 0.5 mm runout of the rotor from zero to full speed. It is not yet clear where the limit of the braid collector lies with respect to gap size. Secondly, rotor displacement due to vibration and shock loading may leave a braid collector damaged to the point of non-operability. If it is found that a braid close-clearance collector is not feasible for full-scale operation, a successful replacement will have to provide the benefits of the braid collector and also address the additional aforementioned problems. Because of their inherent flexibility, metallic fiber brushes wetted with liquid metals offer the possibility of such a replacement. These brushes can presumably hydrodynamically ride on a film of liquid metal minimizing tribologic losses while maintaining the close clearance wicking action of the braid.

The present study is directed at obtaining friction and wear data necessary for the successful implementation of liquid metal wetted fiber brush current collectors.

## EXPERIMENTAL WORK

### Fiber Brush Fabrication

The brushes chosen for the investigations consist of Niobium fibers imbedded in a copper matrix. These brushes were fabricated by Professor Doris Wilsdorf and co-workers at the University of Virginia under contract N61533-78-M-3372 and were based on similar designs for investigating dry fiber brushes.<sup>4,5</sup> The fabrication proceeds by inserting Niobium rods into a billet of copper and drawing of the billet down to a wire. The wire is cut, stacked together and drawn down again to the desired filament size. The stock

material is then cut, lapped to the desired rotor contour and Nitric-acid etched to desired fiber length. Four brushes were provided and the general characteristics are shown in Figure 2. These brushes allow an investigation of the effects of fiber diameter, length and to a lesser extent packing fraction. The low packing fractions were desired to allow for independent movement of the fibers. Niobium was chosen because it was a metallurgically familiar material for this type of fabrication technique, and its electrical resistivity is reasonably low.

### Friction

It was desired to obtain the coefficient of friction of these brushes as a function of applied load both dry and wetted with NaK 78, the liquid metal of choice for current collector applications. As a first step, the stiffness of each brush was determined. The stiffness is defined as the change in load of the brush with compression. The apparatus used to determine the stiffness is shown in Figure 3. The brushes were mounted in a copper block so as to present the brushes curved surface to a simulated rotor section located on a micro balance. The brush advances by micrometer adjustments on the rear of the block. Zero contact could be determined by electrical continuity. The brush compression equals the brush advance minus the scale pan retreat. The results of these measurements are shown in Figure 4.

To evaluate the coefficient of friction an "Atwood" type apparatus shown in Figure 5 was used. The machine consists of two disks, one copper and one aluminum, mounted on ball bearings and driven by accelerating weights on the aluminum disk. The machine is calibrated with no brush contact by varying the accelerating weights and noting the change in time between the photo diode sensed timing marks. This curve is shown in Figure 6. The fiber brush is then mounted to provide a normal load to the copper disk. The normal load is determined by the load-compression curve for the brush. The change in time between the free-running machine and the brush-loaded machine represents the frictional load.

The coefficients of friction for the four brushes were determined for varying loads in the range of expected electrical operation. These loads are based on typical "dry" brush performance and will have to be verified. These

measurements were first done with no liquid metal. The apparatus was then placed in a glove box and the experiments were repeated with liquid metal wetting the brush and rotor.

The brushes were considered "wet", when rubbing the brush fibers in NaK produced a surface coat of liquid metal on the fibers which was not easily removed by mild rubbing against another surface. The rotor was also coated with NaK by "painting" with an extra fiber brush. The tests had to be completed within 20 minutes which represents the time it took before the NaK was visibly reacted and would thus cast doubt on the data. At this point the surfaces would be wiped, rewet and run again.

The results of these tests are shown in Figure 7.

### Wear

Experiments were conducted to determine the wear properties of the lubricated fiber brushes. The rig for this measurement is shown in Figure 8. Not shown, for purposes of clarity, is the plexiglass housing which surrounds the rotor and brushes. This housing serves as a NaK reservoir and splash retainer. The four brushes were loaded to 70 grams and run at 19 m/sec for 900 hours. NaK was present but no current was applied. The test was periodically stopped to physically observe if wetting was present and if deterioration had occurred. At the conclusion of the test, the brushes were removed, ultrasonically cleaned several times in water and methanol and weighed. There was no detectable change in the weight of the brushes as measured on an analytic balance. However the rotor was unacceptably grooved and pitted by all brushes except for A Brush. This is shown in Figure 9 which also shows a typical brush before and after the run. This was considered unacceptable in terms of necessary life time performance in a machine which should have no rotor wear and minimal brush wear.

With the rotor replaced, the brushes were then run under the same conditions without NaK. After 40 hours, the test was stopped and the results are shown on Figure 10. Very severe wear occurred on all brushes, essentially destroying them.

In both the above tests, the brushes and holders provided the loading weight. However, they were allowed to rotate about the fulcrum arm to which

the brush holders were attached. Occasional bounce was observed during this rotation. The rig was modified, to disallow this bounce, with a retaining arm. Brushes A and D were run again with very positive results. After 100 hours the test was stopped, brushes A and D had lost  $10^{-4}$  and  $3.3 \times 10^{-3}$  grams respectively. The pitting and grooving seen in previous runs was not present. Photos of the brushes after the test are shown in Figure 11.

#### DISCUSSION

All the stiffness curves of Figure 4 behave non-linearly. This is believed due to fibers of slightly differing lengths coming into contact with the rotor surface. The stiffness stated in the Figure is therefore obtained from the linear part of the curve. Secondly, there appears to be some hysteresis in the curves. This is presumably due to the fibers trying to skid or plow as they are compressed while tending to slide as they are being released. This phenomenon was quite repeatable (as well as quite tedious). Further evidence for this skidding was the decrease in the amount of scale pan retreat as the pan balance was gently tapped. This is interpreted as the fibers working themselves into a more stable position.

One should be able to predict the stiffness of a brush from a suitable model. The brush can be considered as a collection of cantilevered-struts. The analysis of cantilevered-struts developed by Beth and Wells<sup>6</sup> is reproduced here in very abbreviated form because of its applicability in brush design. The geometry of the problem is shown in Figure 12. One considers a uniform thin rod of length  $L$  and flexural rigidity,  $B = EI$ , where  $E$  is the elastic modulus and  $I$  is the moment of inertia, acted on by a force  $r$  in such a way that  $r$  makes an angle  $\theta_0$  with the tangent to the rod at the clamped end. The dependent variables  $x_1, y_1, z_1$ , and  $v_1$  the elastic strain energy are found as explicit series expressions in terms of  $L, B, r$  and  $\theta_0$ . One first replaces independent variables  $r$  and  $\theta_0$  by dimensionless variables.

$$\rho \equiv L \left(\frac{r}{B}\right)^{1/2} \quad \text{and} \quad \alpha = \cos \theta_0 \quad \beta = \sin \theta_0 \quad (1)$$

and the four dependent variables by dimensionless functions

$$X = x_1/L, Y = y_1/L, Z = \cos \theta_1, \text{ and } W = v_1/rL \quad (2)$$

The unknown functions X, Y, Z and W can be found by means of a single dimensionless function S of the variables  $\alpha$  and  $\rho$ , defined as follows:

$$S(\alpha, \rho) \equiv \rho(1 + Y + W) \quad (3)$$

From elementary beam theory and conservation of energy, one finds that

$$Y = \frac{1}{2} [S/\rho + \frac{\partial S}{\partial \rho}] - 1 \quad (4)$$

while S satisfies the first order, non-linear partial differential equation

$$\frac{\partial S}{\partial \rho} = 1 + \alpha - \frac{1}{2} \beta^2 \left( \frac{\partial S}{\partial \rho} \right)^2 \quad (5)$$

which X, Y, Z, and W no longer appear. S is solved for by standard power series expansion of S in  $\rho$  with the expansion coefficients evaluated by equating corresponding coefficients on both sides of the equation 5.

Substituting the expressions obtained for S in equation (4) one obtains the desired relation for Y,

$$Y = y_1/L = \alpha + \frac{1}{2} \beta^2 \sum_{n=1}^{\infty} (n+1) C_n \rho^{2n} \quad (6)$$

where  $C_n$  are given by:

$$C_1 = 1/3$$

$$C_2 = 2\alpha/15$$

$$C_3 = (23 \alpha^2 - 6)/315$$

$$C_4 = (134 \alpha^3 - 72)/2835$$

$$C_5 = (5297 \alpha^4 - 4338 \alpha^2 + 423)/155925 \quad (7)$$

The first five terms of the series are sufficient for  $\rho$  values up to one. For these brushes  $\rho$  is typically less than 0.5. This then is the functional relationship of compression with load. Similar expressions are available for X, Z, and W. With equations 6 and 7 the stiffness of the four brushes were

evaluated using a value of  $10^{11}$  Nt/m<sup>2</sup> for E,  $I = \frac{\pi d^4}{64}$ , the moment of inertia

for a right circular cylinder with diameter d and the brush parameters of Figure 2. These results, shown in Table 1, are very good except for brush B which was experimentally measured to be less stiff by a factor of 2.5. At present it is not clear why this should be. The reason for this poor correlation in one case will be further studied if equations 6 and 7 are to be used as good general brush design equations.

### Friction

All four brushes showed a decreasing friction coefficient with increasing load when run dry. This does not correlate with the stiffness of the brush as both the stiffest (brush C) and the softest (brush B) showed lower coefficients than brushes A and D which have similar values of stiffness. However, the magnitude of the coefficients is encouraging for mechanical losses if the brushes were to run dry.

The NaK wetting had considerable effect on two brushes (A and D) but relatively little effect on brushes B and C. Brushes B and C are again the brushes with low dry coefficients. It is apparent that brushes A and D will be helped by a liquid metal coated surface whereas brushes B and C would be only slightly so if at all. The trends are the important point for the NaK wetted experiments as the data has considerable uncertainty due to the difficulty in keeping the conditions constant due to NaK reactivity. The NaK wetted coefficients are probably good to  $\pm 50\%$  compared to the dry coefficients which are good to  $\pm 0.5\%$ .

### Wear

As anticipated at the inception of this investigation, the use of a liquid metal greatly reduces the wear one might expect from a non-lubricated brush. The 100 hour tests with the A and the D brushes translate into dimensionless wear coefficients of 3 to  $40 \times 10^{-13}$ . The wear coefficient is defined as the linear dimensional brush loss divided by the distance traveled. This value is 5 to 6 orders of magnitude better than typical monolithic solid brushes.

TABLE 1 - PREDICTED AND MEASURED STIFFNESS FOR FOUR CANDIDATE BRUSHES

		NUMBER OF FIBERS PER BRUSH			
		9728	2052	12765	5365
DIAMETER OF FIBERS MICRONS ( $\mu\text{m}$ )	27	8.6% A 80 g/mil (79)			
	55		7.6% B 25 g/mil (69)		
	34			18.2% C 230 g/mil (270)	
	52				17.8% D 120 g/mil (106)

← FIBER FRACTION  
 ← STIFFNESS, EXPERIMENT  
 ← (CALCULATED CANTILEVER-STRUT)

The control of the brush bounce seems to be most important in this experimental configuration. This factor will be pursued further. The values of the wear coefficient should be obtained based on a longer run time. Initial brush weight loss may occur because of some run in phenomenon and not increase any further. Therefore the actual wear coefficients may be even lower. These tests were concluded because the apparatus was deteriorating. Secondly, the brushes were not forced to carry current which, interacting with its own field or an external field may produce additional loads. Also, the wetting of the brush was inferred from visual observation not from electrical contact drops. A new apparatus is being designed in which the brush will carry current during tests.

The brushes should be re-examined under the conditions of no liquid metal but with no bounce. The brushes may still wear severely, as Niobium is pyrophoric and even trace amounts of oxygen may prove detrimental to their performance. Based on the present results, however, dry Niobium fiber brushes are not good candidates as current collectors.

#### CONCLUSIONS

Friction and wear studies of several candidate Niobium fiber brushes wetted with Nak 78 have been initiated. These studies are considered fundamental to the application of liquid metal wetted, metallic fiber brushes as potential current collectors in high performance acyclic electric machinery.

A model of the fiber brush treated as a collection of cantilevered struts has been developed which predicts brush stiffness to within 15% for three of the four brushes studied. The poor correlation in one case is not clear and will be the subject of further study.

Frictional studies indicate coefficients between .05 and .4 for dry brushes. Liquid metal wetting improved the friction coefficient for two brushes while having slight effect on two others. In general the friction coefficient drops with increasing load for both the dry and wetted brushes. for applied loads of 10 to 200 grams per brush.

Wear studies indicated dimensionless wear coefficients of approximately  $30 \times 10^{-13}$  for several tested brushes when lubricated with NaK. If bounce is not controlled, severe pitting of the rotor can occur. Dry Niobium brushes, free to bounce, wear severely even in a glove box atmosphere.

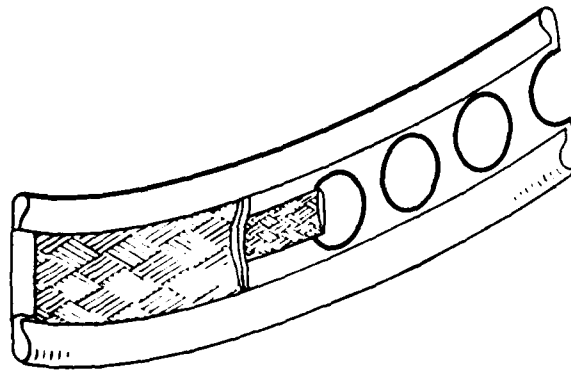
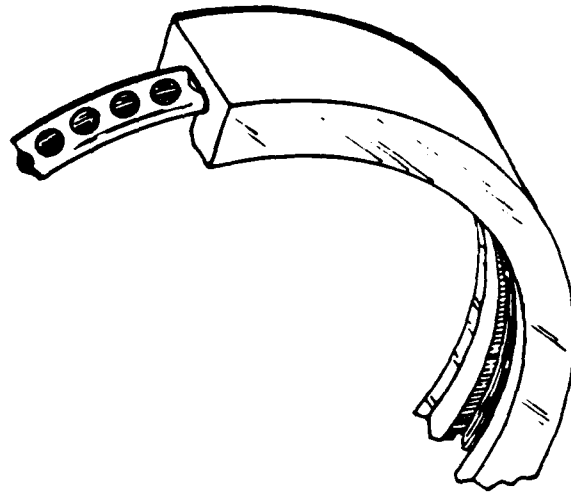
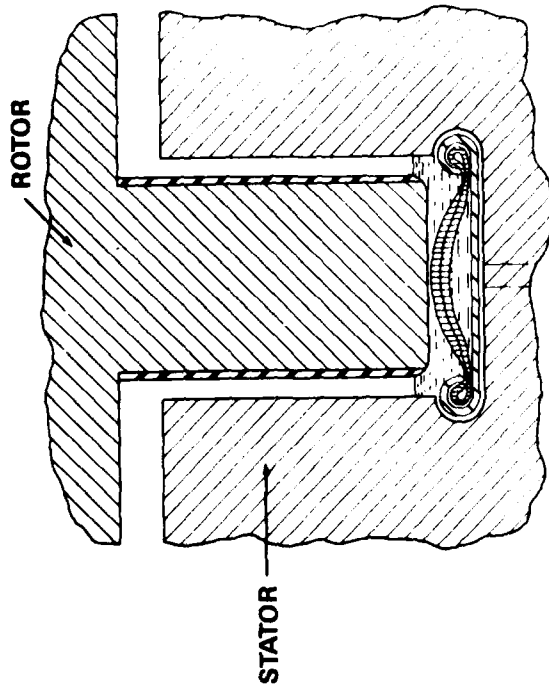

Figure 1 - Three Views of a DTNSRDC Braid Collector

**ALL SAMPLES**

Cu CASE AREA  $0.375 \times 0.375 = 0.140 \text{ in.}^2 = .9032 \text{ cm}^2$

Cu CASE WALL THICKNESS  $0.03 \text{ in.} = .012 \text{ cm}$

NET CASE AREA  $(0.375 - 0.06)^2 = 0.099 \text{ in.}^2 = .015 \text{ cm}^2$

CASE + FIBER LENGTH ONE INCH (NOMINAL) = 2.54 cm

FIBERS AT AN ANGLE OF  $20^\circ$  TO NORMAL

FIBERS RADIUSSED TO FIT A 12.7 cm DIAMETER SLIPRING

BRUSH PAIR	A	B	C	D
FIBER DIAMETER $\mu\text{m}$	27.0	55.0	34.0	52.0
FIBER DIAMETER mils	1.06	2.165	1.34	2.047
FIBERS PER BUNDLE	19.0	19.0	37.0	37.0
BUNDLES PER BRUSH	512.0	108.0	345.0	145.0
TOTAL FIBERS PER BRUSH	9728.0	2052.0	12,765	5365.0
TOTAL FIBER AREA $\text{cm}^2 \cdot 10^{-4}$	5.54	4.87	11.61	11.4
FIBER FRACTION %	8.67	7.63	18.2	17.84

**TYPICAL FIBER BRUSH**

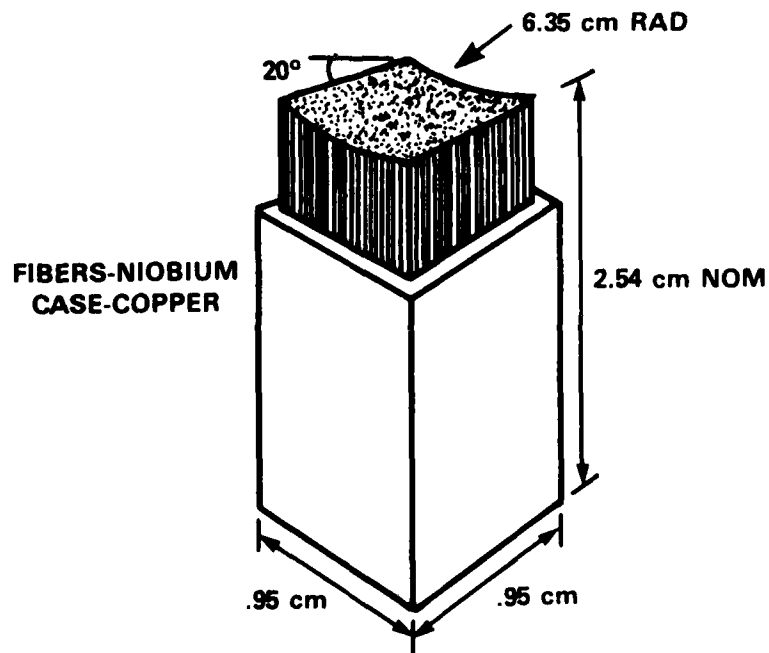
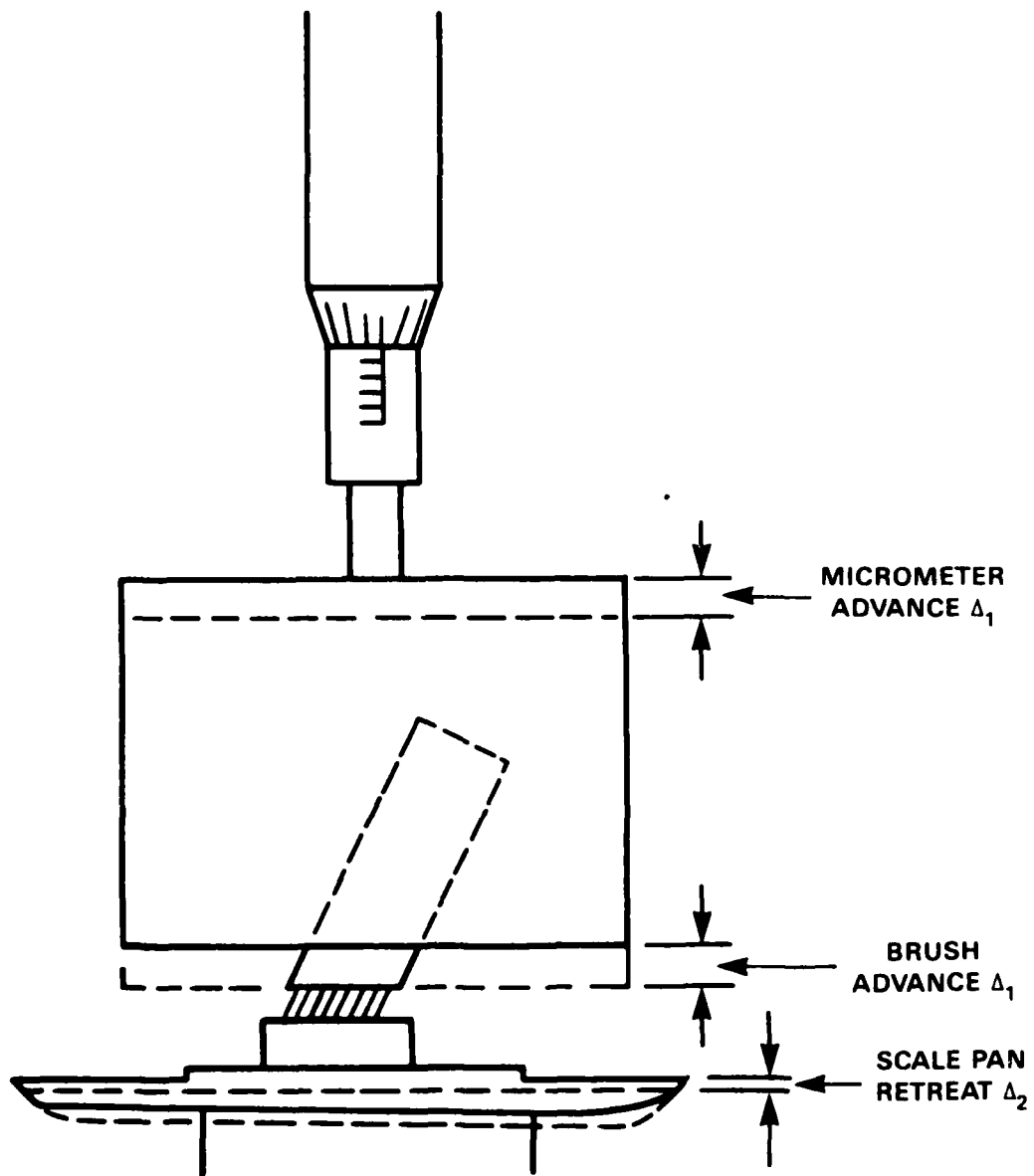

Figure 2 - Characteristics of Niobium Fiber Brushes



**BRUSH COMPRESSION =  $\Delta_1 - \Delta_2$**

**MICRO BALANCE PAN DISPLACEMENT 0.309 mils/g**

**DEAD RECKONING METHOD**

Figure 3 - Method of Determining Brush Compression with Load

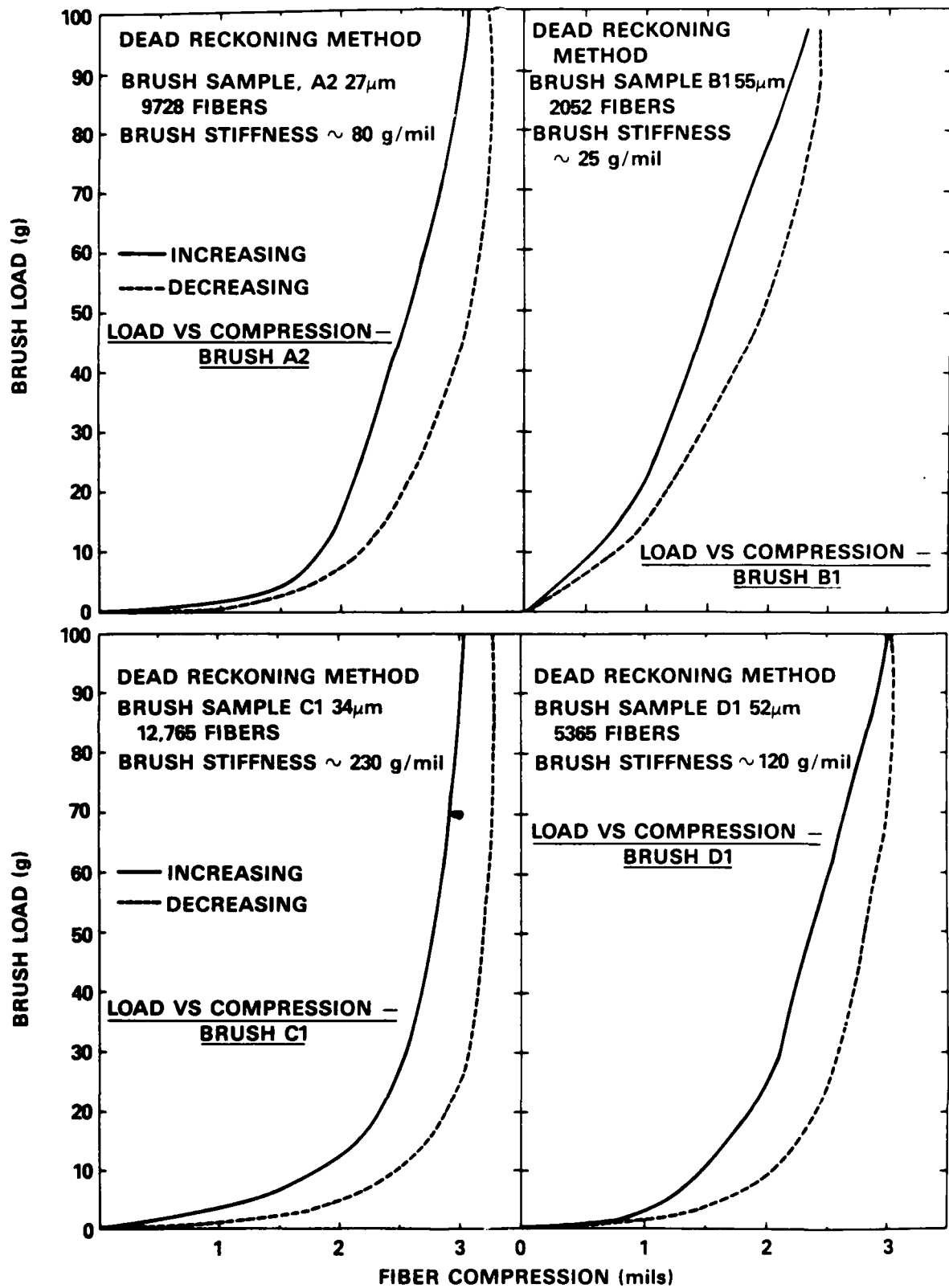

Figure 4 - Fiber Compression vs Load for the Four Candidate Brushes

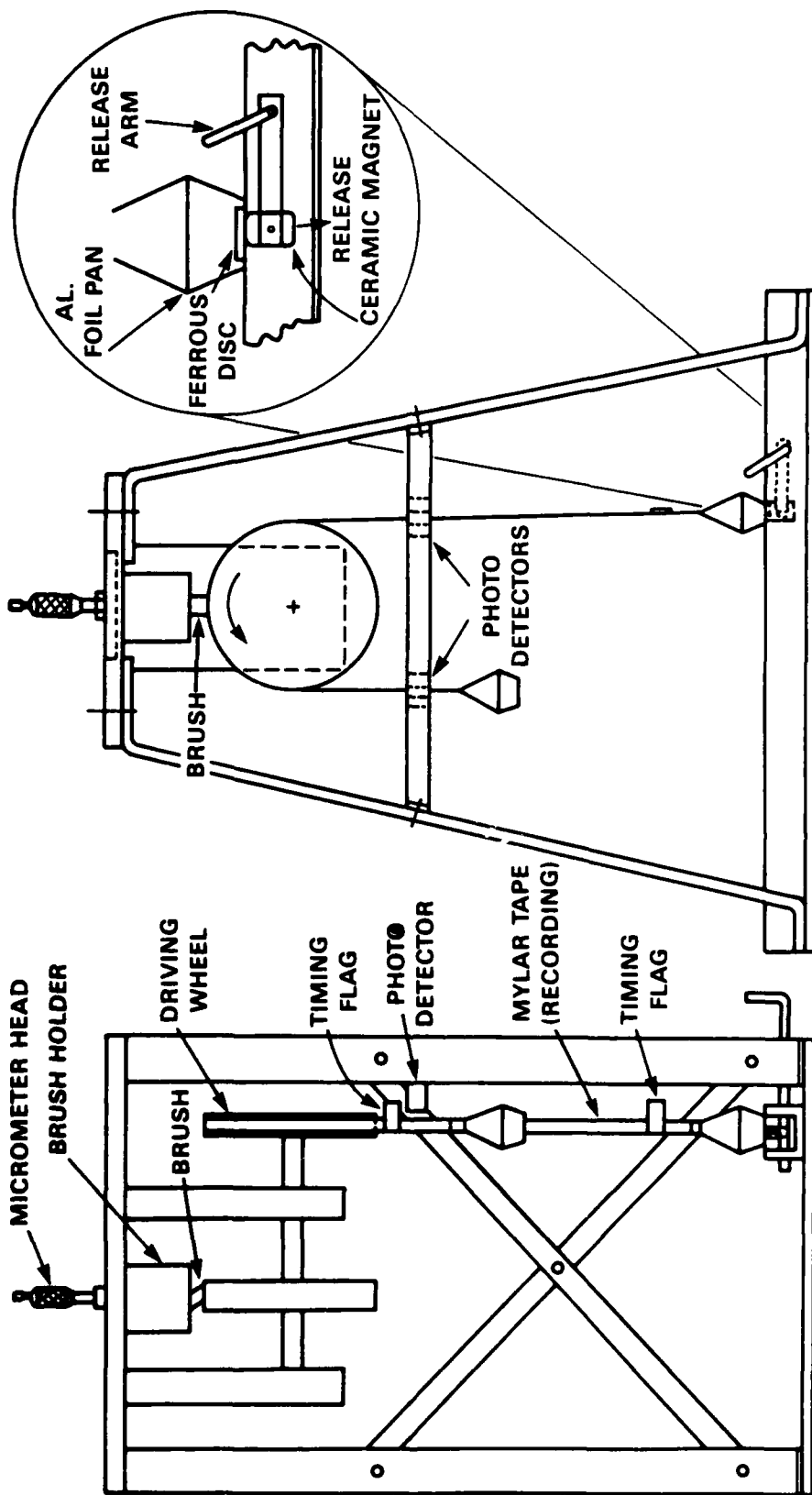

Figure 5 - Friction Measurement Rig

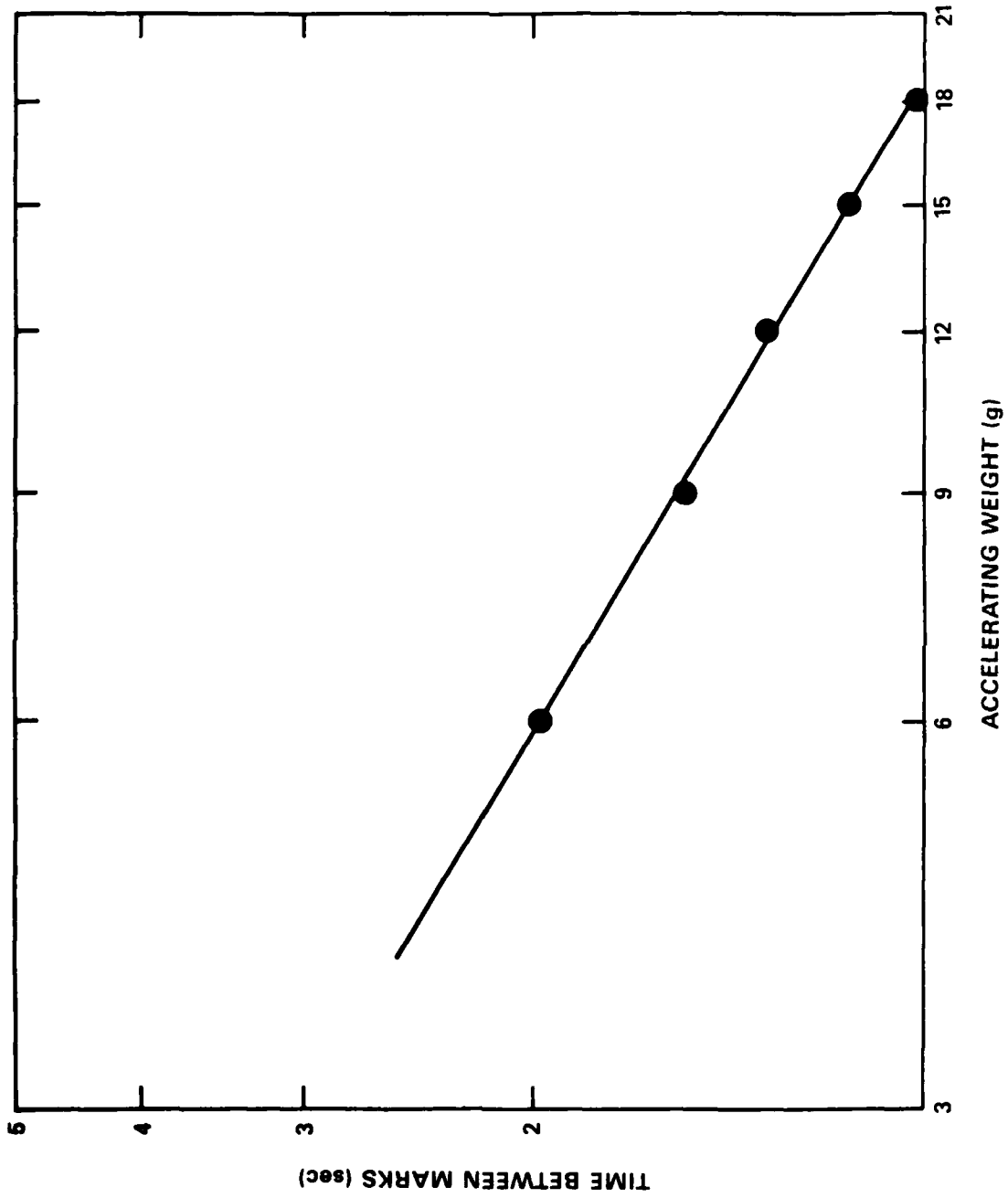

Figure 6 - Friction Measurement Rig Calibration Without Brush

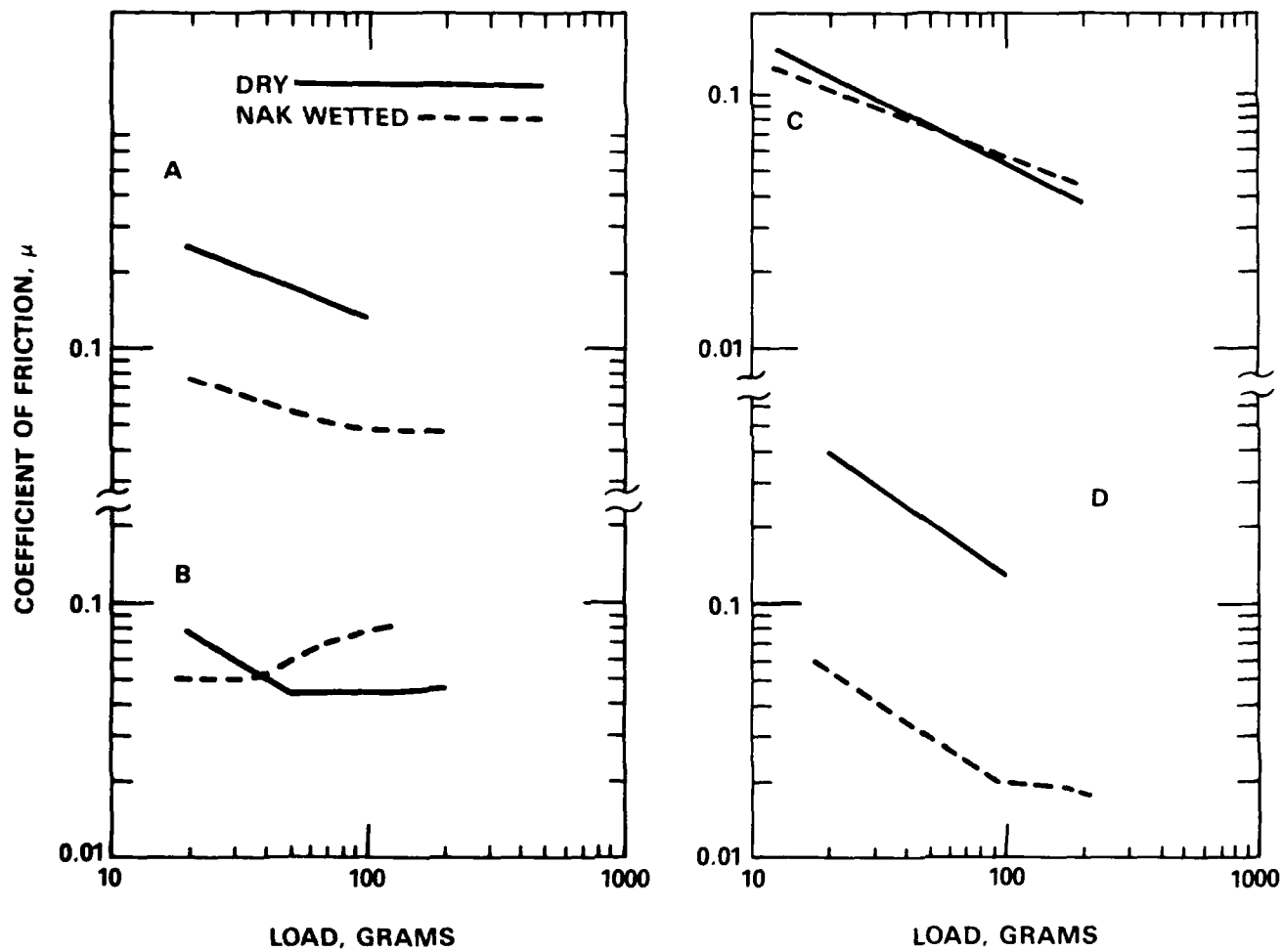

Figure 7 - Coefficient of Friction for Four Candidate Brushes

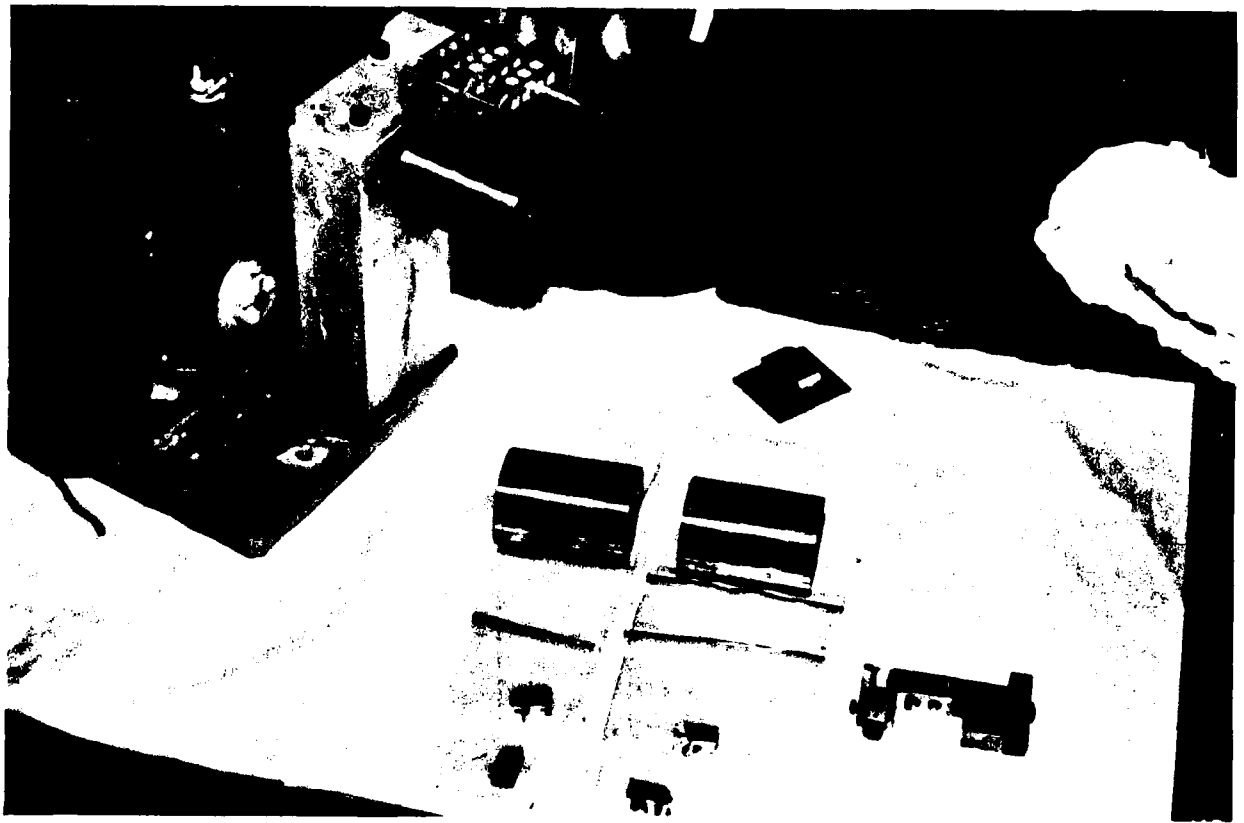

Figure 8 - 19 m/sec Wear Apparatus

Figure 9 - Wear After 900 Hr Run

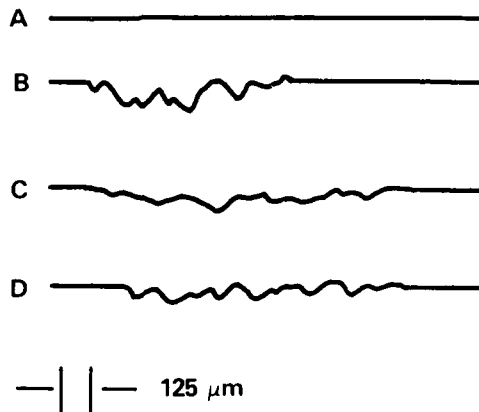

Figure 9a - Cross Section Profile of Rotor Wear for the Four Brush Samples



Figure 9b - Brush C Before and After Run

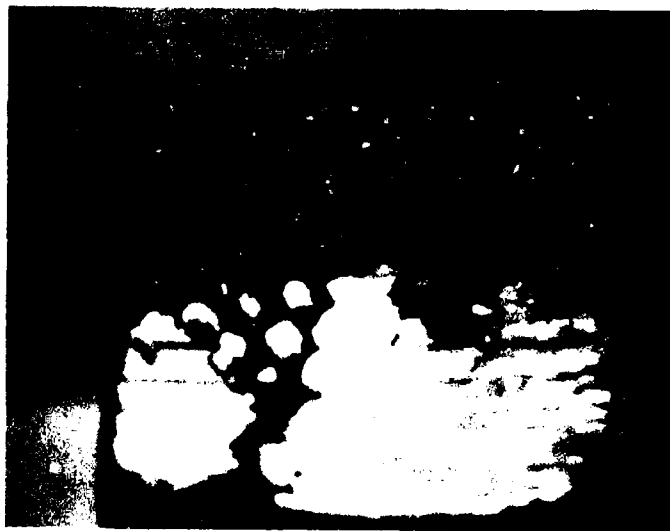

Figure 10 - "B" Brush, No Nak 40 Hour Run

A BRUSH



X 10

D BRUSH



X 10



X 400

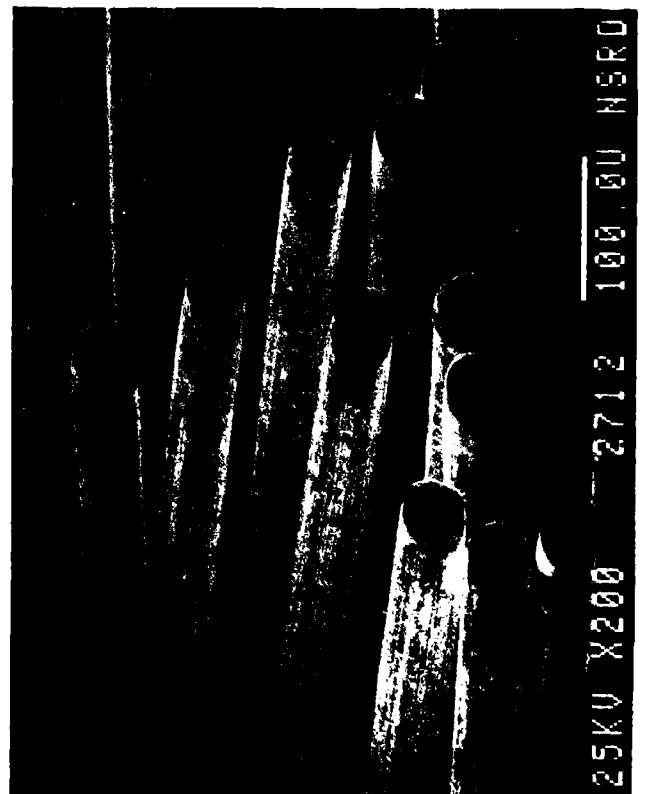

X 200

Figure 11 - Brushes A and D After 100 Hour Bounce Free Wear Run

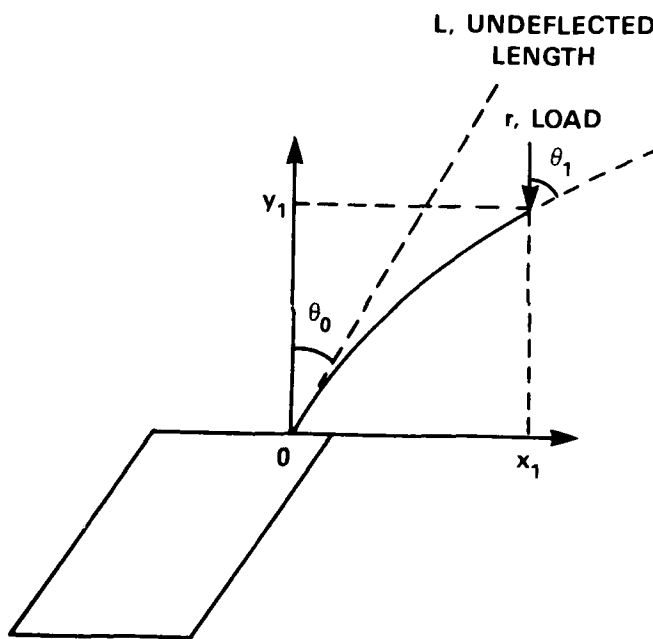

$$\text{COMPRESSION} = \frac{1}{2} \beta^2 \sum_{n=1}^{\infty} (n+1) C_n \rho^{2n}$$

$$C1 = 1/3$$

$$C2 = 2\alpha/15$$

$$C3 = (23\alpha^2 - 6)/315$$

$$C4 = (134\alpha^3 - 72\alpha)/2835$$

$$C5 = (5297\alpha^4 - 4338\alpha^2 + 423)/155925$$

WHERE:

$$\beta = \sin \theta_0$$

$$\alpha = \cos \theta_0$$

$$\rho = L (r/EI)^{1/2}, \quad E = \text{ELASTIC MODULUS}$$

$$I = \text{MOMENT OF INERTIA}$$

Figure 12 - Cantilever Strut Model of Fiber Brush

## REFERENCES

- (1) "Superconducting Machinery for Naval Propulsion," H. O. Stevens, M. J. Superczynski, T. J. Doyle, J. H. Harrison, H. Messigner, IEEE Transactions on Magnetics, Vol., Mag. 13, No. 1, January 1977.
- (2) "Development of Shaped Field Superconducting Motor," T. J. Doyle, and M. J. Cannell, DTNSRDC Report No. 4178, 1974.
- (3) "Acyclic Superconducting Generator Development, 400 Horsepower Generator Design," M. J. Cannell, H. O. Stevens, DTNSRDC Report No. PAS 81/14, 1982.
- (4) "Development of High-Performance Metal Fiber Brushes," C. M. Adkins III and D. Kuhlmann Wilsdorf, Part I and II Electric Contacts 1979 (Illinois Institute of Technology, Chicago, Illinois, 1979), pp. 165-184.
- (5) "Development of High-Performance Metal Fiber Brushes," C. M. Adkins III and D. Kuhlman-Wilsdorf, Part III Electric Contacts 1980 (Illinois Institute of Technology, Chicago, Illinois, 1980) p. 67-72.
- (6) "Finite Deflection of a Cantilever-Strut," R. A. Beth and C. P. Wells, Journal of Appl. Phys., Vol. 22, No. 6 (June 1951).

INITIAL DISTRIBUTION

Copies		CENTER DISTRIBUTION	
		Copies	Code
2	NAVSEA		
	1 SEA 05R31	2	271
	1 SEA 06R		
2	ONR	1	2710
	1 Code 430	3	2711
	1 Code 431		
12	DTIC	15	2712
		1	2702
		1	012
		1	522.1
		2	5231

**DTNSRDC ISSUES THREE TYPES OF REPORTS**

**1. DTNSRDC REPORTS, A FORMAL SERIES, CONTAIN INFORMATION OF PERMANENT TECHNICAL VALUE. THEY CARRY A CONSECUTIVE NUMERICAL IDENTIFICATION REGARDLESS OF THEIR CLASSIFICATION OR THE ORIGINATING DEPARTMENT**

**2. DEPARTMENTAL REPORTS, A SEMIFORMAL SERIES, CONTAIN INFORMATION OF A PRELIMINARY, TEMPORARY, OR PROPRIETARY NATURE OR OF LIMITED INTEREST OR SIGNIFICANCE. THEY CARRY A DEPARTMENTAL ALPHANUMERICAL IDENTIFICATION.**

**3. TECHNICAL MEMORANDA, AN INFORMAL SERIES, CONTAIN TECHNICAL DOCUMENTATION OF LIMITED USE AND INTEREST. THEY ARE PRIMARILY WORKING PAPERS INTENDED FOR INTERNAL USE. THEY CARRY AN IDENTIFYING NUMBER WHICH INDICATES THEIR TYPE AND THE NUMERICAL CODE OF THE ORIGINATING DEPARTMENT. ANY DISTRIBUTION OUTSIDE DTNSRDC MUST BE APPROVED BY THE HEAD OF THE ORIGINATING DEPARTMENT ON A CASE-BY-CASE BASIS.**