

AD-A143 497

NATIONAL PROGRAM FOR INSPECTION OF NON-FEDERAL DAMS  
BRANDEGEE LAKE DAM (C. (U) CORPS OF ENGINEERS WALTHAM  
MA NEW ENGLAND DIV JUN 81

1/1

UNCLASSIFIED

F/G 13/13

NL

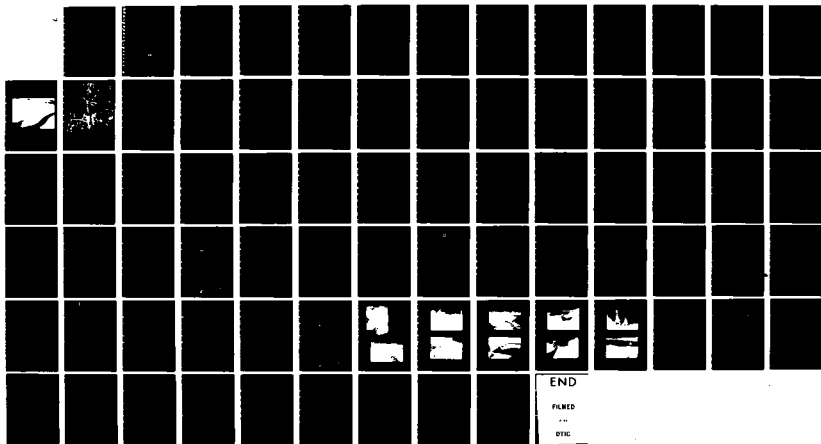

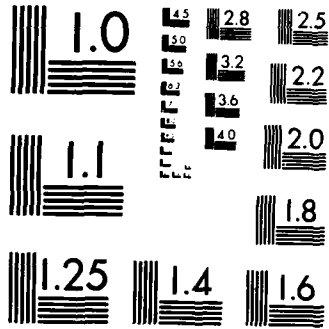

MICROCOPY RESOLUTION TEST CHART  
NATIONAL BUREAU OF STANDARDS-1963-A

THAMES RIVER BASIN  
WATERFORD , CONNECTICUT



AD-A143 497

BRANDEGEE LAKE DAM  
CT. 00153

PHASE I INSPECTION REPORT  
NATIONAL DAM INSPECTION PROGRAM

DTIC FILE COPY

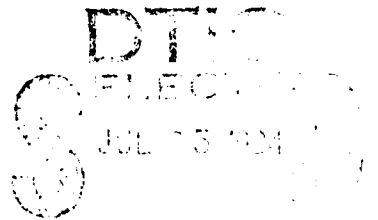

DEPARTMENT OF THE ARMY  
NEW ENGLAND DIVISION, CORPS OF ENGINEERS  
WALTHAM, MASS.

JUNE 1981

84 07 24 105

UNCLASSIFIED

SECURITY CLASSIFICATION OF THIS PAGE (When Data Entered)

REPORT DOCUMENTATION PAGE		READ INSTRUCTIONS BEFORE COMPLETING FORM	
1. REPORT NUMBER CT 00153	2. GOVT ACCESSION NO.	3. RECIPIENT'S CATALOG NUMBER	
4. TITLE (and Subtitle) Brandegee Lake Dam		5. TYPE OF REPORT & PERIOD COVERED INSPECTION REPORT	
NATIONAL PROGRAM FOR INSPECTION OF NON-FEDERAL DAMS		6. PERFORMING ORG. REPORT NUMBER	
7. AUTHOR(s) U.S. ARMY CORPS OF ENGINEERS NEW ENGLAND DIVISION		8. CONTRACT OR GRANT NUMBER(s)	
9. PERFORMING ORGANIZATION NAME AND ADDRESS		10. PROGRAM ELEMENT, PROJECT, TASK AREA & WORK UNIT NUMBERS	
11. CONTROLLING OFFICE NAME AND ADDRESS DEPT. OF THE ARMY, CORPS OF ENGINEERS NEW ENGLAND DIVISION, NEDED 424 TRAPELO ROAD, WALTHAM, MA. 02254		12. REPORT DATE June 1981	
		13. NUMBER OF PAGES 55	
14. MONITORING AGENCY NAME & ADDRESS (if different from Controlling Office)		15. SECURITY CLASS. (of this report) UNCLASSIFIED	
		15a. DECLASSIFICATION/DOWNGRADING SCHEDULE	
16. DISTRIBUTION STATEMENT (of this Report) APPROVAL FOR PUBLIC RELEASE: DISTRIBUTION UNLIMITED			
17. DISTRIBUTION STATEMENT (of the abstract entered in Block 20, if different from Report)			
18. SUPPLEMENTARY NOTES Cover program reads: Phase I Inspection Report, National Dam Inspection Program; however, the official title of the program is: National Program for Inspection of Non-Federal Dams; use cover date for date of report.			
19. KEY WORDS (Continue on reverse side if necessary and identify by block number) DAMS, INSPECTION, DAM SAFETY, Thames River Basin Waterford, Conn. Brandegee Lake Dam			
20. ABSTRACT (Continue on reverse side if necessary and identify by block number) Brandegee Lake dam is 450 ft. long earthfill structure with a concrete core wall. The dam has a crest width of 12 ft, an upstream slope of 2:1 and a downstream slope of 1.5:1. The spillway is 28 ft. long. The dam is classified as SMALL in size and a SIGNIFICANT hazard structure in accordance with recommended guidelines established by the Corps of Engineers. The dam is considered to be in fair condition.			



DEPARTMENT OF THE ARMY  
NEW ENGLAND DIVISION, CORPS OF ENGINEERS  
424 TRAPELO ROAD  
WALTHAM, MASSACHUSETTS 02254

REPLY TO  
ATTENTION OF:  
NEDED

AUG 19 1981

Honorable William A. O'Neill  
Governor of the State of Connecticut  
State Capitol  
Hartford, Connecticut 06115

Dear Governor O'Neill:

Inclosed is a copy of the Brandegeee Lake Dam (CT-00153) Phase I Inspection Report, prepared under the National Program for Inspection of Non-Federal Dams. This report is based upon a visual inspection, a review of the past performance and a brief hydrological study of the dam. I approve the report and support the findings and recommendations described in Section 7 and ask that you keep me informed of the actions taken to implement them. This follow-up action is vitally important.

Copies of this report have been forwarded to the Department of Environmental Protection, and to the owner, City of New London, Connecticut. Copies will be available to the public in thirty days.

I wish to thank you and the Department of Environmental Protection for your cooperation in this program.

Sincerely,

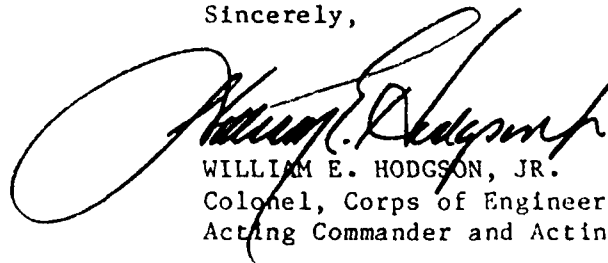

WILLIAM E. HODGSON, JR.  
Colonel, Corps of Engineers  
Acting Commander and Acting Division Engineer

Incl  
As stated

Accession For	
NTIS GRA&I	<input checked="" type="checkbox"/>
DTIC TAB	<input type="checkbox"/>
Unannounced	<input type="checkbox"/>
Justification	
By _____	
Distribution/	
Availability Codes	
Dist	Avail and/or Special
R/1	



BRANDEGEE LAKE DAM

CT 00153

THAMES RIVER BASIN  
WATERFORD, CONNECTICUT

PHASE 1 INSPECTION REPORT  
NATIONAL DAM INSPECTION PROGRAM

# NATIONAL DAM INSPECTION REPORT

## PHASE 1 INSPECTION REPORT

IDENTIFICATION NO: CT 00153  
NAME OF DAM: Brandegee Lake Dam  
COUNTY AND STATE: New London County,  
Connecticut  
STREAM: Great Swamp Brook  
DATE OF INSPECTION: 20 May 1981

### Brief Assessment

Brandegee Lake dam is a 450 foot long earthfill structure with a concrete core wall. The dam has a crest width of 12 feet, an upstream slope of 2:1 and a downstream slope of 1.5:1. The spillway is 28 feet long, has a crest elevation of 129.5 NGVD and a trapezoidal weir. The maximum height of the dam is 15 feet. The dam has a impoundment capacity of 530 acre-feet at the top of dam elevation of 133.5 NGVD and is used for recreation.

The dam is classified as SMALL in size and a SIGNIFICANT hazard structure in accordance with recommended guidelines established by the Corps of Engineers. Based on the size and hazard classifications, the adopted test flood for this structure is equal to one-half the Probable Maximum Flood (PMF) which is estimated to be 600 CSM, or 1,080 CFS, from the 1.8 square mile drainage basin. This test flood has a routed outflow discharge equal to 930 CFS and would overtop the dam by 0.2 feet. The maximum spillway capacity is equal to 785 CFS which represents 84% of the test flood outflow.

Based on a visual inspection at the site, the dam is considered to be in FAIR condition. However, these are several areas of concern which must be corrected to assure the long-term performance of this dam. It is recommended that the owner engage the services of a registered engineer experienced in the design of dams to accomplish the following:

1. Perform a detailed hydrologic/hydraulic investigation to assess further the need for and the means to increase project discharge capacity and the ability of the dam to withstand overtopping.
2. Recommend methods to rehabilitate the gatehouse and the low level outlet to provide a means to draw down the reservoir for emergencies or for maintenance.

3. Design repairs for the eroded crest and upstream slope at the right side of the spillway.
4. Recommend procedures to remove brush, trees, and their root systems from the crest and slopes to a distance of 15 feet downstream and backfill the holes with selected material.
5. Design erosion protection for the upstream face of the dam at the right abutment.

These and other recommendations and remedial measures as described in Section 7 should be implemented by the owner within one year after receipt of this Phase 1 Inspection Report.

NEW ENGLAND ENGINEERING, INC.

BY:

*David A. Sluter*  
David A. Sluter, P.E.  
President

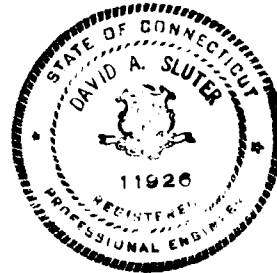

This Phase I Inspection Report on Brandegee Lake Dam (CT-00153) has been reviewed by the undersigned Review Board members. In our opinion, the reported findings, conclusions, and recommendations are consistent with the Recommended Guidelines for Safety Inspection of Dams, and with good engineering judgement and practice, and is hereby submitted for approval.



ARAMAST MAHTESIAN, MEMBER  
Geotechnical Engineering Branch  
Engineering Division

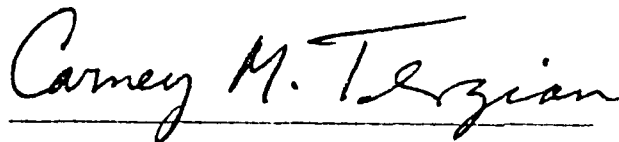

CARNEY M. TERZIAN, MEMBER  
Design Branch  
Engineering Division

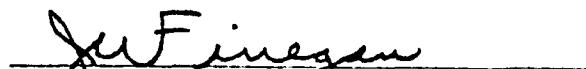

JOSEPH W. FINEGAN, JR., CHAIRMAN  
Water Control Branch  
Engineering Division

APPROVAL RECOMMENDED:

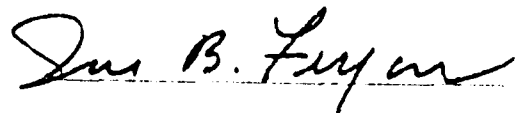

JOE B. FRYAR  
Chief, Engineering Division

## PREFACE

This report is prepared under guidance contained in the Recommended Guidelines for Safety Inspection of Dams, for Phase 1 Investigations. Copies of these guidelines may be obtained from the Office of Chief of Engineers, Washington, DC 20314. The purpose of a Phase 1 Investigation is to identify expeditiously those dams which may pose hazards to human life or to property. The assessment of the general condition of the dam is based upon available data and visual inspections. Detailed investigations, testing, and detailed computational evaluations are beyond the scope of a Phase 1 investigation; however, the investigation is intended to identify any need for such studies.

In reviewing this report, it should be realized that the reported condition of the dam is based on observations of field conditions at the time of inspection along with data available to the inspection team. In cases where the reservoir was lowered or drained prior to inspection such action, while improving the stability and safety of the dam, removes the normal load on the structure and may obscure certain conditions which might otherwise be detectable if inspected under the normal operating environment of the structure.

It is important to note that the condition of a dam depends on numerous and constantly changing internal conditions, and is evolutionary in nature. It would be incorrect to assume that the present condition of the dam will continue to represent the condition of the dam at some point in the future. Only through continued care and inspection can there be any chance that unsafe conditions be detected.

Phase 1 inspections are not intended to provide detailed hydrologic and hydraulic analyses. In accordance with the established Guidelines, the Spillway Test Flood is based on the estimated "Probable Maximum Flood" for the region (greatest reasonable possible storm runoff), or fractions thereof. Because of the magnitude and rarity of such a storm event, a finding that a spillway will not pass the test flood should not be interpreted as necessarily posing a highly inadequate condition. The test flood provides a measure of relative spillway capacity and serves as an aid in determining the need for more detailed hydrologic and hydraulic studies, considering the size of the dam, its general condition, and the downstream damage potential.

The Phase 1 Investigation does not include an assessment of the need for fences, gates, no-trespassing signs, repairs to existing fences and railings and other items which may be needed to minimize trespass and provide greater security for the facility and safety to the public. An evaluation of the project for compliance with OSHA rules and regulations is also excluded.

## TABLE OF CONTENTS

<u>Section</u>	<u>Page</u>
LETTER OF TRANSMITTAL	
BRIEF ASSESSMENT	
REVIEW BOARD PAGE	
PREFACE	i
TABLE OF CONTENTS	ii
OVERVIEW PHOTO	
LOCATION MAP	

### REPORT

1. PROJECT INFORMATION	1-1
1.1 General	1-1
a. Authority	1-1
b. Purpose of Inspection	1-1
1.2 Description of Project	1-1
a. Location	1-1
b. Description of the Dam & Appurtenances	1-2
c. Size Classification	1-2
d. Hazard Classification	1-2
e. Ownership	1-2
f. Operator	1-2
g. Purpose of the Dam	1-3
h. Design and Construction History	1-3
i. Normal Operational Procedures	1-3
1.3 Pertinent Data	1-3
a. Drainage Area	1-3
b. Discharge at Damsite	1-3
c. Elevations	1-4
d. Reservoir Lengths	1-4
e. Storage	1-4
f. Reservoir Surface Area	1-5
g. Dam	1-5
h. Diversion and Regulating Tunnels	1-5
i. Spillway	1-5
j. Regulating Outlets	1-6

<u>Section</u>	<u>Page</u>
2. ENGINEERING DATA	2-1
2.1 Design Data	2-1
2.2 Construction Data	2-1
2.3 Operation Data	2-1
2.4 Evaluation of Data	2-1
a. Availability	2-1
b. Adequacy	2-1
c. Validity	2-1
3. VISUAL INSPECTION	3-1
3.1 Findings	3-1
a. General	3-1
b. Dam	3-1
c. Appurtenant Structures	3-2
d. Reservoir Area	3-3
e. Downstream Channel	3-3
3.2 Evaluation	3-3
4. OPERATIONAL PROCEDURES	4-1
4.1 Operational Procedures	4-1
a. General	4-1
b. Description of any Warning System in Effect	4-1
4.2 Maintenance Procedures	4-1
a. General	4-1
b. Operating Facilities	4-1
4.3 Evaluation	4-1
5. EVALUATION OF HYDRAULIC/HYDROLOGIC FEATURES	5-1
5.1 General	5-1
5.2 Design Data	5-1
5.3 Experience Data	5-1
5.4 Test Flood Analysis	5-1
5.5 Dam Failure Analysis	5-2

<u>Section</u>	<u>Page</u>
6. EVALUATION OF STRUCTURAL STABILITY	6-1
6.1 Visual Observations	6-1
6.2 Design & Construction Data	6-1
6.3 Post-Construction Changes	6-1
6.4 Seismic Stability	6-2
7. ASSESSMENT, RECOMMENDATION & REMEDIAL MEASURES	7-1
7.1 Dam Assessment	7-1
a. Condition	7-1
b. Adequacy of Information	7-1
c. Urgency	7-1
7.2 Recommendations	7-1
7.3 Remedial Measures	7-2
a. Operation & Maintenance Procedures	7-2
7.4 Alternatives	7-2

APPENDICES

APPENDIX A	INSPECTION CHECKLIST
APPENDIX B	ENGINEERING DATA
APPENDIX C	PHOTOGRAPHS
APPENDIX D	HYDROLOGIC & HYDRAULIC COMPUTATIONS
APPENDIX E	INFORMATION AS CONTAINED IN THE NATIONAL INVENTORY OF DAMS



OVERVIEW PHOTO - Brandegge Lake Dam

May 20, 1981

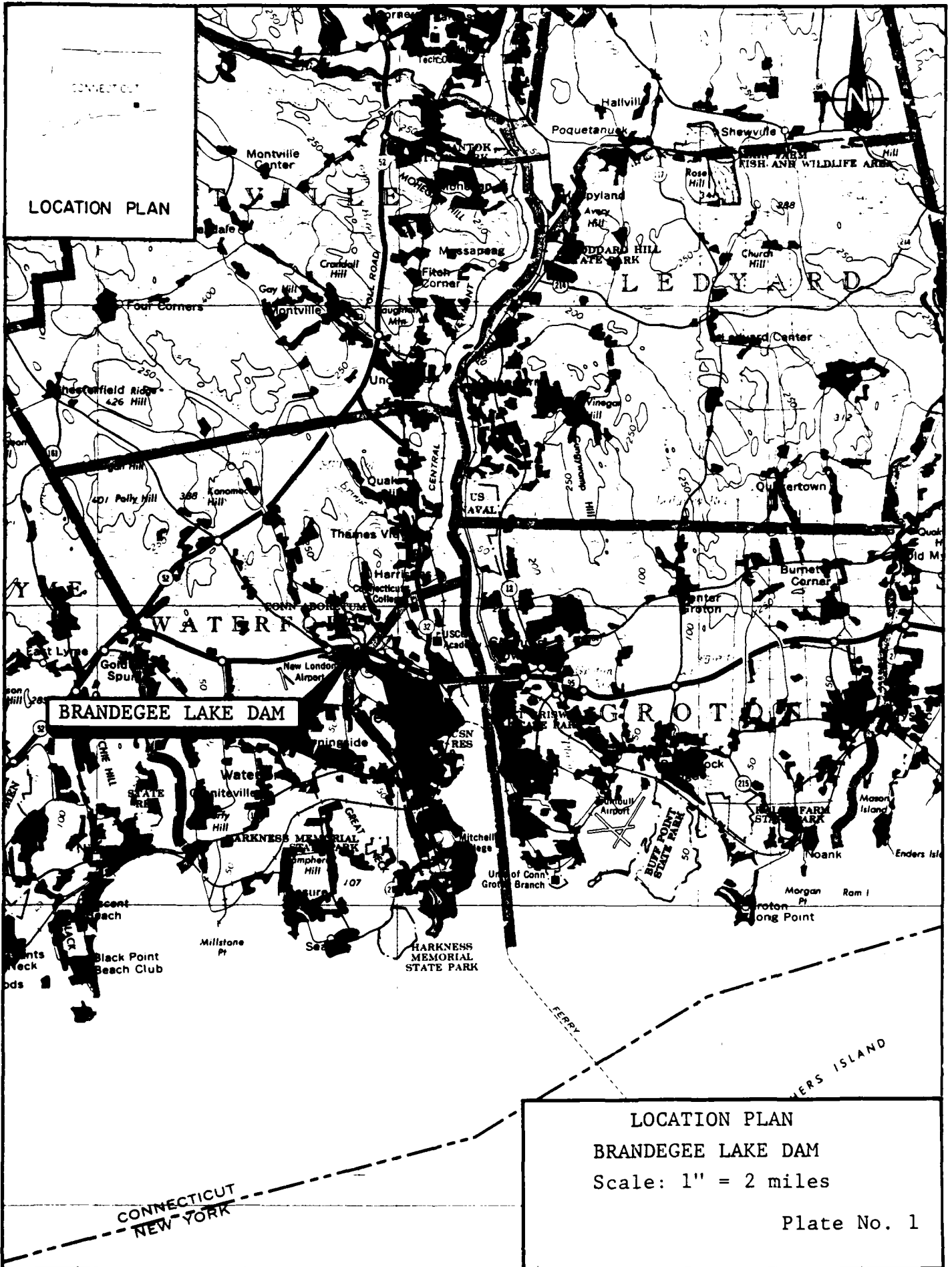

NATIONAL DAM INSPECTION PROGRAM

PHASE 1 - INSPECTION PROGRAM

BRANDEGEE LAKE DAM

SECTION 1

PROJECT INFORMATION

1.1 General

- a. Authority. Public Law 92-367, August 8, 1972, authorized the Secretary of the Army through the Corps of Engineers to initiate a national program of dam inspection throughout the United States. The New England Division of the Corps of Engineers has been assigned the responsibility of supervising the inspection of dams within the New England Region. New England Engineering, Inc. has been retained by the New England Division to inspect and report on selected dams in the State of Connecticut. Authorization and notice to proceed was issued to New England Engineering, Inc. under a letter from William E. Hodgson, Jr., Colonel, Corps of Engineers. Contract No. DACW33-81-C-0007 has been assigned by the Corps of Engineers for this work.
- b. Purpose of Inspection.
  1. Perform technical inspection and evaluation of non-Federal dams to identify conditions which threaten the public safety and thus permit correction in a timely manner by non-Federal interests.
  2. Encourage and assist the State to initiate quickly effective dam safety programs for non-Federal dams.
  3. To update, verify, and complete the National Inventory of Dams.

1.2 Description of the Project

- a. Location. Brandegge Lake Dam is located in Waterford, New London County, Connecticut on Great Swamp Brook approximately 7,000 feet north of the mouth of the brook at the Thames River. Coordinates of the dam are approximately 41 degrees, 22.3' North Latitude, and 72 degrees, 07.4' West Longitude as shown on the New London USGS Quadrangle Sheet. The dam impounds water from Great Swamp Brook which drains a 1.8 square mile watershed of rolling, wooded terrain. The axis of the reservoir is oriented in a Northwest-Southeast direction with the dam at the southeastern extremity of the reservoir.

- b. Description of Dam and Appurtenances. Brandegee Lake Dam is approximately 450 feet long including the spillway. The dam has a maximum height of 15 feet and is an earthfill structure with a concrete core wall. The core wall has a top width of 20 inches, a batter of 1/2 inch on each side and apparently extends to bedrock or other impervious zone. The dam has an upstream slope of 2:1, a downstream slope of 1.5:1, and a crest width of 12 feet. The spillway is located approximately 100 feet right of the left abutment, is 28 feet long, and has a crest elevation of 129.5 NGVD. The spillway discharges flow to a 1500 foot long, 7 foot diameter concrete culvert at the toe of the dam. An abandoned brick gatehouse with a granite block foundation is located at the right edge of the spillway. The access door and windows to this gatehouse have been sealed with masonry blocks and the low level outlet is inoperable. The low level outlet consists of a 12 inch cast iron pipe blowoff. This blowoff is apparently a wye or tee connection to the 20 inch cast iron main water supply line which was plugged and abandoned sometime after construction.
- c. Size Classification. This dam has an impoundment capacity of 530 Ac-Ft at the top of the dam (elevation 133.5 NGVD) and a maximum height of 15 feet. In accordance with the guidelines established by the Corps of Engineers, this dam is classified as SMALL in size based on its impoundment capacity. Corps of Engineers guidelines specify that dams with impoundment capacities less than 1,000 Ac-Ft and greater than or equal to 50 Ac-Ft or a height of less than 40 feet and greater than or equal to 25 feet be classified as SMALL in size.
- d. Hazard Classification. This dam is classified a SIGNIFICANT hazard potential because its failure could result in a loss of a few lives and inundation of several parking lots and the Interstate 95 Frontage Road downstream of the dam. It is estimated that a dam failure discharge of 1,140 CFS could produce a depth of flooding of 2-3 feet in the parking lot immediately downstream of the dam and 1 foot deep in other parking lots and the Frontage Road. The dam failure discharge was computed assuming the water level in the reservoir to be equal to the top of dam elevation of 133.5 NGVD at the time of failure.
- e. Ownership. The dam is presently owned by the City of New London, Connecticut.

- f. Operator. The dam is operated by the Water Department of the City of New London: Mr. Gordon Beckwith, Superintendent of Water, 181 State Street, New London, Connecticut 06320. Phone number (203) 433-2861.
- g. Purpose of the Dam. The dam is used for recreation.
- h. Design and Construction History. The dam was originally constructed in 1897 to serve as a water supply facility, however, it was never used for its intended purpose because of poor water quality. The spillway discharge channel was reconstructed in 1972 with a concrete floor and training walls. The spillway now discharges to a 7 foot diameter, 1500 foot long concrete culvert which was also constructed in 1972.
- i. Normal Operating Procedures. The level of the reservoir is not normally controlled and all flow from the dam results from discharges over the uncontrolled spillway.

1.3 Pertinent Data

- a. Drainage Area. The Brandegee Lake Dam drainage basin is oval in shape with an average length of approximately 2 miles, a width of 1 mile and a total drainage area of 1.8 square miles (See Appendix D for the basin map). Approximately 20 percent of the basin is man-made or natural storage. The topography consists of rolling terrain with elevations ranging from a high of 302 feet to 129.5 feet at the spillway crest. Basin slopes are considered moderate.
- b. Discharge at Damsite. There are no discharge records available for this dam. Calculated discharge data for the dam is listed below.

1. Outlet Works

Conduit & Size	12 inch diameter cast iron pipe blowoff. Invert = 117.9 feet NGVD (Inoperable)
2. Maximum known flood at damsite	Unknown
3. Ungated spillway capacity at top of dam	785 CFS
4. Ungated spillway capacity at test flood elevation	845 CFS

- 5. Gated spillway capacity at normal pool elevation N/A
- 6. Gated spillway capacity at test flood elevation N/A
- 7. Total spillway capacity at test flood elevation 845 CFS
- 8. Total project discharge at top of dam 785 CFS
- 9. Total project discharge at test flood elevation 930 CFS

c. Elevations (NGVD)

- 1. Streambed at toe of dam 118.5
- 2. Bottom of cutoff Varies
- 3. Maximum tailwater Unknown
- 4. Normal pool 129.5
- 5. Full flood control pool N/A
- 6. Spillway crest 129.5
- 7. Design surcharge (Original Design) Unknown
- 8. Top of dam 133.5
- 9. Test flood 133.7

d. Reservoir Lengths (in feet)

- 1. Normal pool 3,000
- 2. Flood control pool N/A
- 3. Spillway crest pool 3,000
- 4. Top of dam 3,000
- 5. Test flood pool 3,000

e. Storage (acre-feet)

- 1. Normal pool 350
- 2. Flood control pool N/A
- 3. Spillway crest pool 350

- |     |                                        |                                                        |
|-----|----------------------------------------|--------------------------------------------------------|
| 4.  | Top of dam                             | 530                                                    |
| 5.  | Test flood pool                        | 540                                                    |
| f.  | <u>Reservoir Surface Area (Acres)</u>  |                                                        |
| 1.  | Normal pool                            | 45                                                     |
| 2.  | Flood control pool                     | N/A                                                    |
| 3.  | Spillway crest                         | 45                                                     |
| 4.  | Top of dam                             | 45                                                     |
| 5.  | Test flood pool                        | 45                                                     |
| g.  | <u>Dam</u>                             |                                                        |
| 1.  | Type                                   | Earth embankment                                       |
| 2.  | Length                                 | 450 feet                                               |
| 3.  | Height                                 | 15 feet maximum                                        |
| 4.  | Top width                              | 12 feet                                                |
| 5.  | Side slopes                            | 2:1 U/S; 1.5:1 D/S                                     |
| 6.  | Zoning                                 | Homogeneous embankment with concrete core wall         |
| 7.  | Impervious Core                        | Concrete core wall                                     |
| 8.  | Cutoff                                 | Extension of core wall to bedrock or impervious layer. |
| 9.  | Grout Curtain                          | None                                                   |
| 10. | Other                                  | No comment.                                            |
| h.  | <u>Diversion and Regulating Tunnel</u> |                                                        |
|     |                                        | N/A                                                    |
| i.  | <u>Spillway</u>                        |                                                        |
| 1.  | Type                                   | Uncontrolled trapezoidal weir                          |
| 2.  | Length of Weir                         | 28 feet                                                |
| 3.  | Crest Elevation                        | 129.5                                                  |
| 4.  | Gates                                  | None                                                   |
| 5.  | U/S Channels                           | Natural bed of reservoir                               |

- |    |                          |                                                                           |
|----|--------------------------|---------------------------------------------------------------------------|
| 6. | D/S Channel              | Concrete channel to 7 feet diameter culvert                               |
| 7. | General                  | Culvert is 1500 feet long and discharges to Perry Pond.                   |
| j. | <u>Regulating Outlet</u> |                                                                           |
| 1. | Invert                   | 117.9 feet                                                                |
| 2. | Size                     | 12 inch diameter pipe                                                     |
| 3. | Description              | Cast iron pipe blowoff from 20" main water supply line which was plugged. |
| 4. | Control mechanism        | Manually operated vertical lift gate                                      |
| 5. | Other                    | Gatehouse sealed and outlet is inoperable                                 |

## SECTION 2

### ENGINEERING DATA

#### 2.1 Design

There is no available documentation regarding the design of this facility. Construction drawings are available at the City of New London Water Department and selected drawings are included in Appendix B.

#### 2.2 Construction

No records of the original dam construction are available. Construction drawings for the original construction in 1897 are available from the City of New London.

Records of the reconstruction of the spillway discharge channel and culvert are available from the Connecticut Department of Transportation.

#### 2.3 Operation

No operational records are maintained.

#### 2.4 Evaluation

- a. Availability. There is no design information available.
- b. Adequacy. The lack of in-depth engineering data did not allow for a definitive review. Therefore, the adequacy of this dam could not be assessed from the standpoint of reviewing design and construction data, but is based primarily on visual inspection, past performance and sound engineering judgement.
- c. Validity. No design data is available.

## SECTION 3

### VISUAL INSPECTION

#### 3.1 Findings

- a. General. The Phase 1 visual inspection of the Brandegee Lake Dam was conducted on May 20, 1981 by representatives of New England Engineering, Inc. and Geotechnical Engineers, Inc. A visual checklist and photographic record of that inspection have been included in Appendix A and C, respectively, of this report. At the time of the inspection, the water level was at the spillway crest elevation of 129.5.

Based on the visual inspection, the dam is judged to be in FAIR condition.

- b. Dam. The dam is an earth embankment structure approximately 450 feet in length with a maximum height of 15 feet. The earth embankment contains a concrete core wall, has an upstream slope of 2:1, a downstream slope of 1.5:1 and a crest width of 12 feet. The spillway has a length of 28 feet and is located 100 feet right of the left abutment. The outlet gatehouse is located to the right of the spillway and its door and windows have been sealed with concrete blocks. The outlet is inoperable.
1. Upstream Face. the upstream face of the earth embankment section has 50-300 pound stone riprap protection to the crest (Photo C-4). Small trees and brush cover the upstream slope from the edge of the reservoir to the crest of the dam. (Photo C-1). There is a zone of the upstream face at the right abutment contact which is apparently used for access to the lake and is not protected by riprap (Photo C-5). This zone is not vegetated and has no protection against wave action and runoff erosion.
  2. Crest. The crest of the dam is 12 feet wide and is shown on Photos C-1 and C-2. To the right of the spillway the crest is bare dirt and has been eroded to a depth of 18 inches near the right spillway training wall (photo C-6). On the upstream slope, this erosion has caused the granite blocks between the gatehouse and the right spillway training wall to move 2 feet in the downstream direction (Photo C-6). To the left of the spillway, the crest is fully covered with brush and small trees.

3. Downstream Face and Toe. The downstream face of the dam to the right of the spillway is covered with low brush and grass (Photo C-3). Eight to ten white pine trees, approximately 10 years old, have been planted in rows on the downstream face to the right of the spillway. To the left of the spillway, the downstream face is covered with dense brush and small trees. The entrance to the spillway discharge culvert is located at the toe of the dam at station 3+20.

c. Appurtenant Structures

1. Spillway. The spillway is located 100 feet to the right of the left abutment and is 28 feet wide with a crest elevation of 129.5 NGVD (Photos C-7 and C-8). The spillway discharge channel was resurfaced in 1972 with concrete and a culvert was constructed which carries all discharges to Perry Pond located 1500 feet downstream (Photo C-7). The concrete paving of the channel has a misaligned construction joint approximately 20 feet downstream from the crest. The downstream slab at this joint is approximately 1/2 inch higher than the upstream slab (Photo C-8). This joint should be observed in the future to determine if movement is occurring.

Some clear seepage is occurring through the left and right discharge channel training walls. The seepage through the left training wall is less than 1 gpm and is occurring 5 feet upstream of the entrance to the culvert and 1 foot above the channel floor (Photo C-7). The seepage through the right training wall was less than 1 gpm and was occurring through and around the outlets of two pipes through the wall (Photo C-9).

2. Gatehouse and Outlet. The gatehouse which was constructed to serve as a intake/outlet structure is located to the right of the spillway (Photo C-8). This gatehouse is abandoned and its windows and door have been sealed (Photos C-8, C-7). The low level outlet from the dam is now inoperable. The outlet was originally constructed with a 20 inch cast iron pipe to serve for water supply. A 12 inch cast iron blowoff from the 20 inch main to the spillway discharge channel served as the outlet. The 20 inch cast iron pipe was plugged and abandoned sometime after the original dam construction. The 12 inch blowoff was relocated to its present location during the reconstruction of the spillway discharge channel in 1972.

- d. Reservoir Area. No specific detrimental features in the reservoir area were observed during the visual inspection.
- e. Downstream Channel. A 7 foot diameter concrete culvert forms the downstream channel for the dam. This culvert is 1500 feet long and carries discharges from the dam to Perry Pond.

### 3.2 Evaluation

Based on the visual inspection, the dam appears to be in FAIR condition. The following features could adversely affect the future performance of the dam and should be investigated:

- a. The inoperable low level outlet.
- b. The eroded zone on the crest and upstream face at the right spillway training wall.
- c. The absence of riprap on the upstream face at the right abutment.
- d. The brush, trees and their root systems on all slopes and to a distance of 15 feet downstream. The roots of such trees can dislodge the riprap and penetrate the core wall from the downstream side if allowed to grow. When the trees are tall, wind storms can uproot trees and leave holes in the embankment.

## SECTION 4

### OPERATIONAL AND MAINTENANCE PROCEDURES

#### 4.1 Operation Procedures

- a. General. The outlet works are inoperable. All discharges flow over the spillway crest to the spillway discharge culvert.
- b. Description of Any Warning System in Effect. There is no warning system in effect for Brandegee Lake Dam.

#### 4.2 Maintenance Procedures

- a. General. The dam and appurtenances are not maintained.
- b. Operating Facilities. There are no operating facilities at the dam.

#### 4.3 Evaluation

- a. The facility is not properly maintained, monitored or regulated by the Owner. The outlet works are inoperable and the gatehouse is abandoned.
- b. Trees and brush on all surfaces of the embankment have not been removed annually.
- c. There is no regularly scheduled maintenance for this dam. There are several maintenance deficiencies as described above. A systematic inspection and rehabilitation program should be developed and implemented. The low level outlet and gatehouse should be rehabilitated so that the reservoir level may be regulated, if required.
- d. An emergency action plan should also be developed and implemented that includes procedures to lower the reservoir level, locations of emergency equipment, materials or manpower to reduce or minimize dam failure damage, authorities to be contacted in emergency situations and a program of surveillance during unusual storm events.

## SECTION 5

### EVALUATION OF HYDRAULIC/HYDROLOGIC FEATURES

#### 5.1 General

The Brandegee Lake Dam was constructed in 1897 for water supply but was never used for that purpose. The dam is now used for recreation. The dam is located on the Great Swamp Brook in the Connecticut Coastal Basin. The watershed for the reservoir is 1.8 square miles with approximately 20% of this basin man-made or natural storage.

The dam has a spillway length of 28 feet and a maximum height of 15 feet. The total length of the dam is 450 feet including the spillway. The reservoir has a storage capacity at the spillway crest of 350 Ac-Ft. Each foot of depth above the spillway level can accomodate 45 Ac-Ft of water equivalent to 0.30 inches of runoff.

#### 5.2 Design Data

Little specific data is available for this watershed or structure. In lieu of existing complete design information, U.S.G.S. topographic maps (scale 1" = 2,000') were utilized to develop hydrologic parameters such as drainage area, reservoir surface areas, basin slopes and other runoff characteristics. Elevation-storage relationships for the reservoir were approximated. Some of the pertinent hydraulic data was obtained or confirmed by actual field measurements at the time of the visual inspection. Test flood inflows and outflows and dam failure flows were determined in accordance with the Corps of Engineers guidelines.

#### 5.3 Experience Data

No historical data for recorded discharges is available for this dam.

#### 5.4 Test Flood Analysis

Recommended guidelines for the Safety Inspection of Dams by the Corps of Engineers were used for selection of the Test Flood. This dam is classified under those guidelines as a SIGNIFICANT hazard and SMALL in size. Guidelines indicate that a flood equal to the 100-year flood to one-half the PMF be used as a range of test floods for such a classification. A test flood equal to 1/2 the PMF was selected because of the potential downstream damage. The watershed has a total drainage area equal to 1.8 square miles of which approximately 20% is man-made or natural storage. This drainage area is sparsely populated, fairly wooded, with rolling topography.

A test flood value was selected from the Corps of Engineers PMF curve for a watershed with flat to rolling topography and reduced by 20% for storage within the watershed. The test flood inflow was calculated to be 600 CSM, equal to 1,080 CFS and was adopted for this analysis. The routed outflow discharge for the test flood inflow was 930 CFS. The spillway rating curve is illustrated in Appendix D. Flood routing was performed assuming a full reservoir at the spillway crest elevation of 129.5 NGVD.

The analysis indicated that the peak test flood outflow would overtop the dam by approximately 0.2 feet. The maximum outflow capacity of the spillway at the top of dam elevation 133.5 is 785 CFS which is 84% of the test flood outflow.

### 5.5 Dam Failure Analysis

For this analysis a full-depth, partial-width breach was assumed to have occurred in this dam. The adopted breach width of 30 feet was based on the dam height and cross section. A dam failure discharge of 1,140 CFS was calculated assuming the reservoir level to be at the top of dam elevation 133.5. The dam failure discharge of 1,140 CFS will produce a depth of flooding of 3 feet at the toe of the dam. It is estimated that failure could result in the loss of a few lives and a flood wave with a depth of 2-3 feet through a portion of the parking lot downstream of the dam. One additional parking lot downstream of the dam and the Interstate 95 Frontage Road would be subject to a high velocity flood wave approximately 1 foot deep. The parking lots serve a large shopping center and a bowling alley. No flooding downstream of the dam would occur prior a dam failure. The prime impact area that would be subject to damage if the dam were to fail has been delineated on the Dam Failure Impact Area Map in Appendix D. As a result of the failure analysis, the dam has been classified as a SIGNIFICANT hazard structure.

## SECTION 6

### EVALUATION OF STRUCTURAL STABILITY

#### 6.1 Visual Observations

Visual examination of the geotechnical and structural aspects of the dam do not indicate any immediate stability problems. However, the following features could affect the long-term stability of the dam.

The erosion that has occurred to the right of the spillway has lowered the crest elevation by about 13 inches and has penetrated about 2 feet into the upstream face. Continuation of this process eventually would lead to washout of part of the embankment. The concrete core wall exists about 2.5 feet below the original crest or about 1.0 feet below the eroded surface. The core wall was not observed, but it would tend to limit the effects of continued erosion.

#### 6.2 Design and Construction Data

The construction drawings indicate that the shells were rolled in 6-inch layers. The upstream shell was specified to be constructed of "selected" material. The as-built drawings indicate that a concrete core wall was used. The concrete core wall is 1.7 feet wide at the top and 3 feet wide at the bottom.

A concrete cutoff wall apparently was carried through the overburden to bedrock or an impervious soil. The cutoff extends a maximum of about 10 feet below the base of the dam.

#### 6.3 Post-Construction Changes

The 20 inch cast iron water supply outlet was plugged at some time subsequent to construction and the gatehouse was abandoned, according to the records. Thus, the lake cannot be lowered except by the use of emergency procedures. The 12" cast iron blowoff which served as the low level outlet was relocated to its present location during the reconstruction of the spillway outlet channel in 1972.

The spillway discharge channel was repaved with concrete in 1972 and a 7 foot diameter culvert was constructed to carry the discharges from the dam to Perry Pond located 1,500 feet downstream.

#### 6.4 Seismic Stability

The dam is located in Seismic Zone 1 and, in accordance with recommended Phase 1 guidelines, does not warrant seismic stability analysis.

## SECTION 7

### ASSESSMENT, RECOMMENDATIONS AND REMEDIAL MEASURES

#### 7.1 Dam Assessment

- a. Condition. Based on the visual inspection, this dam is judged to be in FAIR condition. Features which could adversely affect the condition of the dam in the future are:
  1. Erosion of the crest and upstream face near the right spillway training wall.
  2. The inoperable low level outlet.
  3. Lack of riprap on the upstream face at the right abutment.
- b. Adequacy of Information. The available information is such that the assessment of the condition of the dam must be based on visual observation.
- c. Urgency. The recommendations and remedial measures described below should be implemented by the owner within one year after receipt of the Phase 1 report.

#### 7.2 Recommendations

The following items should be carried out under the direction of a qualified registered engineer and recommendations resulting should be implemented by the owner.

- a. Perform a detailed hydrologic/hydraulic investigation to assess further the need for and the means to increase project discharge capacity and the ability of the dam to withstand overtopping.
- b. Rehabilitate the low level outlet and gatehouse.
- c. Design repairs for the eroded crest and upstream slope on the right side of the spillway.
- d. Design and supervise the placement of riprap on the upstream face of the embankment at the right abutment.
- e. Establish procedures for removal of trees, brush and root systems from the crest, slopes, and to a distance of 15 feet downstream of the dam. Provide specifications for backfilling the holes and for applying erosion protection.

### 7.3 Remedial Measures

#### a. Operation and Maintenance Procedures

1. Develop an "Emergency Action Plan" that will include an effective preplanned downstream warning system, locations of emergency equipment, materials and manpower, authorities to contact and potential areas that require evacuation.
2. Observe at least annually the longitudinal joint in the concrete paving of the spillway discharge channel. If the differential movement at the joint increases, an engineer should be engaged to provide necessary recommendations.
3. Observe the seeps in the training walls of the spillway discharge channel at least quarterly to determine whether any changes are occurring.
4. Implement a regular maintenance program for the facility.
5. Institute a program of annual technical inspection by a qualified registered engineer.
6. Establish protective grass cover over all bare areas.

### 7.4 Alternatives

There are no practical alternatives to the recommendations and remedial measures discussed above.

APPENDIX A

INSPECTION CHECKLIST

VISUAL INSPECTION CHECKLIST  
PARTY ORGANIZATION

PROJECT BRANDEGEE LAKE DAM

DATE May 20, 1981

TIME 0745-1000

WEATHER Fair 65°

W.S. ELEV. 129.6 U.S. 113.2 DN.S.

PARTY:

- |                              |           |
|------------------------------|-----------|
| 1. <u>David Sluter - NEE</u> | 6. _____  |
| 2. <u>Steve Fodor - NEE</u>  | 7. _____  |
| 3. <u>Steve Poulos - GEI</u> | 8. _____  |
| 4. _____                     | 9. _____  |
| 5. _____                     | 10. _____ |

PROJECT FEATURE	INSPECTED BY	REMARKS
1. <u>Structural, Hydraulier &amp; Hydrology</u>	<u>Sluter, Fodor</u>	
2. <u>Geotechnical Poulos</u>		
3. _____		
4. _____		
5. _____		
6. _____		
7. _____		
8. _____		
9. _____		
10. _____		

PERIODIC INSPECTION CHECKLIST

PROJECT BRANDEGEE LAKE DAM DATE May 20, 1981  
 PROJECT FEATURE Structural, H & H NAME Sluter, Fodor  
 DISCIPLINE Geotechnical NAME Poulos

AREA EVALUATED	CONDITION
<p><u>DAM EMBANKMENT</u></p> <p>1 Crest Elevation</p> <p>2 Current Pool Elevation</p> <p>3 Maximum Impoundment to Date</p> <p>4 Surface Cracks</p> <p>5 Pavement Condition</p> <p>6 Movement or Settlement of Crest</p> <p>7 Lateral Movement</p> <p>8 Vertical Alignment</p> <p>9 Horizontal Alignment</p> <p>10 Condition at Abutment and at Concrete Structures</p> <p>11 Indications of Movement of Structural Items on Slopes</p> <p>12 Trespassing on Slopes</p> <p>13 Sloughing or Erosion of Slopes or Abutments</p> <p>14 Rock Slope Protection - Riprap Failures</p>	<p>133.5</p> <p>129.6</p> <p>Unknown.</p> <p>None observed.</p> <p>None. Unpaved - dirt road on crest.</p> <p>Not observable.</p> <p>None observed.</p> <p>Satisfactory.</p> <p>None observed.</p> <p>Right upstream: Erosion due to runoff into pond. No vegetation at abutment contact.                      Right downstream: Satisfactory.                      Left upstream at spillway: Eroded 18 in. below crest of training wall due to trespassing. Surface is bank-run gravel, slightly silty.                      Left downstream: Eroded - dirt-covered. Much less than upstream - just a path.</p> <p>Granite blocks on upstream face between gatehouse and right spillway training wall have moved (due to ice?) ~2 ft at training wall and 2 in. at gatehouse.</p> <p>Free access.</p> <p>Chiefly at spillway and at right upstream contact. See 10.</p> <p>Very good. 50 to 300 lb stone well secured all the way to crest. Does not wrap around right abutment contact. Granite blocks serve as riprap between gatehouse and left spillway training wall. See 11.</p>

PERIODIC INSPECTION CHECKLIST

PROJECT BRANDEGEE LAKE DAM DATE May 20, 1981  
 PROJECT FEATURE Structural, H & H NAME Sluter, Fodor  
 DISCIPLINE Geotechnical NAME Poulos

AREA EVALUATED	CONDITION
<p><u>DAM EMBANKMENT (CON'T.)</u></p> <p>15 Unusual Movement or Cracking at or Near Toe</p> <p>16 Unusual Embankment or Downstream Seepage</p> <p>17 Piping or Boils</p> <p>18 Foundation Drainage Features</p> <p>19 Toe Drains</p> <p>20 Instrumentation System</p> <p>21 Vegetation</p>	<p>None.</p> <p>None.</p> <p>None observed.</p> <p>None.</p> <p>None.</p> <p>None.</p> <p>Black cherry brush to 6' on upstream slope. Few white pines, planted - 12 ft high on downstream slope, grass between trees. Left side of spillway - heavy brush and low trees. Poison ivy.</p>

PERIODIC INSPECTION CHECKLIST

PROJECT BRANDEGEE LAKE DAM DATE May 20, 1981  
 PROJECT FEATURE Structural, H & H NAME Sluter, Fodor  
 DISCIPLINE Geotechnical NAME Poulos

AREA EVALUATED	CONDITION
<p><u>DIKE EMBANKMENT</u></p> <ul style="list-style-type: none"> <li>Crest Elevation</li> <li>Current Pool Elevation</li> <li>Maximum Impoundment to Date</li> <li>Surface Cracks</li> <li>Pavement Condition</li> <li>Movement or Settlement of Crest</li> <li>Lateral Movement</li> <li>Vertical Alignment</li> <li>Horizontal Alignment</li> <li>Condition at Abutment and at Concrete Structures</li> <li>Indications of Movement of Structural Items on Slopes</li> <li>Trespassing on Slopes</li> <li>Sloughing or Erosion of Slopes or Abutments</li> <li>Rock Slope Protection - Riprap Failures</li> <li>Unusual Movement or Cracking at or Near Toes</li> <li>Unusual Embankment or Downstream Seepage</li> <li>Piping or Boils</li> <li>Foundation Drainage Features</li> <li>Toe Drains</li> <li>Instrumentation System</li> <li>Vegetation</li> </ul>	<p>No dike.</p>

PERIODIC INSPECTION CHECKLIST

PROJECT BRANDEGEE LAKE DAM DATE May 20, 1981  
 PROJECT FEATURE Structural, H & H NAME Sluter, Fodor  
 DISCIPLINE Geotechnical NAME Poulos

AREA EVALUATED	CONDITION
<p><u>OUTLET WORKS - INTAKE CHANNEL AND INTAKE STRUCTURE</u></p> <p>a. Approach Channel</p> <p style="padding-left: 40px;">Slope Conditions</p> <p style="padding-left: 40px;">Bottom Conditions</p> <p style="padding-left: 40px;">Rock Slides or Falls</p> <p style="padding-left: 40px;">Log Boom</p> <p style="padding-left: 40px;">Debris</p> <p style="padding-left: 40px;">Condition of Concrete Lining</p> <p style="padding-left: 40px;">Drains or Weep Holes</p> <p>b. Intake Structure</p> <p style="padding-left: 40px;">Condition of Concrete</p> <p style="padding-left: 40px;">Stop Logs and Slots</p>	<p>Under water.</p> <p>Not visible.</p> <p>None.</p> <p>None.</p> <p>None.</p> <p>N/A.</p> <p>N/A.</p> <p>Abandoned.</p> <p>N/A.</p> <p>N/A.</p>

PERIODIC INSPECTION CHECKLIST

PROJECT BRANDEGEE LAKE DAM DATE May 20, 1981  
 PROJECT FEATURE Structural, H & H NAME Sluter, Fodor  
 DISCIPLINE Geotechnical NAME Poulos

AREA EVALUATED	CONDITION
<p><u>OUTLET WORKS - CONTROL TOWER</u></p> <p>a. Concrete and Structural</p> <ul style="list-style-type: none"> <li>General Condition</li> <li>Condition of Joints</li> <li>Spalling</li> <li>Visible Reinforcing</li> <li>Rusting or Staining of Concrete</li> <li>Any Seepage or Efflorescence</li> <li>Joint Alignment</li> <li>Unusual Seepage or Leaks in Gate Chamber</li> <li>Cracks</li> <li>Rusting or Corrosion of Steel</li> </ul> <p>b. Mechanical and Electrical</p> <ul style="list-style-type: none"> <li>Air Vents</li> <li>Float Wells</li> <li>Crane Hoist</li> <li>Elevator</li> <li>Hydraulic System</li> <li>Service Gates</li> <li>Emergency Gates</li> <li>Lightning Protection System</li> <li>Emergency Power System</li> <li>Wiring and Lighting System</li> </ul>	<p>None.</p>

PERIODIC INSPECTION CHECKLIST

PROJECT BRANDEGEE LAKE DAM DATE May 20, 1981  
 PROJECT FEATURE Structural, H & H NAME Sluter, Fodor  
 DISCIPLINE Geotechnical NAME Poulos

AREA EVALUATED	CONDITION
<p><u>OUTLET WORKS - TRANSITION AND CONDUIT</u></p> <p>General Condition of Concrete</p> <p>Rust or Staining on Concrete</p> <p>Spalling</p> <p>Erosion or Cavitation</p> <p>Cracking</p> <p>Alignment of Monoliths</p> <p>Alignment of Joints</p> <p>Numbering of Monoliths</p>	<p>None.</p>

PERIODIC INSPECTION CHECKLIST

PROJECT BRANDEGEE LAKE DAM DATE May 20, 1981

PROJECT FEATURE Structural, H & H NAME Sluter, Fodor

DISCIPLINE Geotechnical NAME Poulos

AREA EVALUATED	CONDITION
<p><u>OUTLET WORKS - OUTLET STRUCTURE AND OUTLET CHANNEL</u></p> <p>General Condition of Concrete</p> <p>Rust or Staining</p> <p>Spalling</p> <p>Erosion or Cavitation</p> <p>Visible Reinforcing</p> <p>Any Seepage or Efflorescence</p> <p>Condition at Joints</p> <p>Drain holes</p> <p>Channel</p> <p>    Loose Rock or Trees Overhanging Channel</p> <p>    Condition of Discharge Channel</p>	<p>N/A.</p> <p>N/A.</p> <p>N/A.</p> <p>N/A.</p> <p>N/A.</p> <p>N/A.</p> <p>N/A.</p> <p>N/A.</p> <p>The abandoned discharge may have been plugged or it may have been diverted into the spillway discharge channel. An 18 in. diameter opening in the right training wall of spillway, about 40 ft downstream from downstream crestline, may be the discharge. See spillway information on page 8 for channel information.</p>

PERIODIC INSPECTION CHECKLIST

PROJECT BRANDEGEE LAKE DAM DATE May 20, 1981

PROJECT FEATURE Structural, H & H NAME Sluter, Fodor

DISCIPLINE Geotechnical NAME Poulos

AREA EVALUATED	CONDITION
<p><u>OUTLET WORKS - SPILLWAY WEIR, APPROACH AND DISCHARGE CHANNELS</u></p> <p>a. Approach Channel</p> <p>    General Condition</p> <p>    Loose Rock Overhanging Channel</p> <p>    Trees Overhanging Channel</p> <p>    Floor of Approach Channel</p> <p>b. Weir and Training Walls</p> <p>    General Condition of Concrete and stone masonry     Rust or Staining</p> <p>    Spalling</p> <p>    Any Visible Reinforcing</p> <p>    Any Seepage or Efflorescence</p> <p>    Drain Holes</p> <p>c. Discharge Channel</p> <p>    General Condition</p> <p>    Loose Rock Overhanging Channel</p> <p>    Trees Overhanging Channel</p> <p>    Floor of Channel</p> <p>    Other Obstructions</p> <p>    Other Comments</p>	<p>Good.</p> <p>None.</p> <p>None - (shore of lake forms left boundary. It is wooded.) Under water.</p> <p>Good - Stone masonry needs some reporting. None.</p> <p>None.</p> <p>None.</p> <p>None.</p> <p>Mortared stone masonry. Mortar is missing in some locations, probably allowing drainage.</p> <p>Good concrete paving - enters 7 ft diameter culvert. None.</p> <p>None.</p> <p>Concrete paving. Differential settlement at joint causes small jump about 20 ft downstream from crest. Downstream side of paving is higher than upstream side. None.</p> <p>A few seeps from concrete training walls 30-40' downstream from crest. On right, seeps wet wall at 5-6' below top of wall. At left seep is clear at &lt;1 gpm 8' below top of wall.</p>

PERIODIC INSPECTION CHECKLIST

PROJECT BRANDEGEE LAKE DAM DATE May 20, 1981  
 PROJECT FEATURE Structural, H & H NAME Sluter, Fodor  
 DISCIPLINE Geotechnical NAME Poulos

AREA EVALUATED	CONDITION
<p><u>OUTLET WORKS - SERVICE BRIDGE</u></p> <p>a. Super Structure</p> <ul style="list-style-type: none"> <li>Bearings</li> <li>Anchor Bolts</li> <li>Bridge Seat</li> <li>Longitudinal Members</li> <li>Underside of Deck</li> <li>Secondary Bracing</li> <li>Deck</li> <li>Drainage System</li> <li>Railings</li> <li>Expansion Joints</li> <li>Paint</li> </ul> <p>b. Abutment &amp; Piers</p> <ul style="list-style-type: none"> <li>General Condition of Concrete</li> <li>Alignment of Abutment</li> <li>Approach to Bridge</li> <li>Condition of Seat &amp; Backwall</li> </ul>	<p>None.</p>

APPENDIX B

ENGINEERING DATA

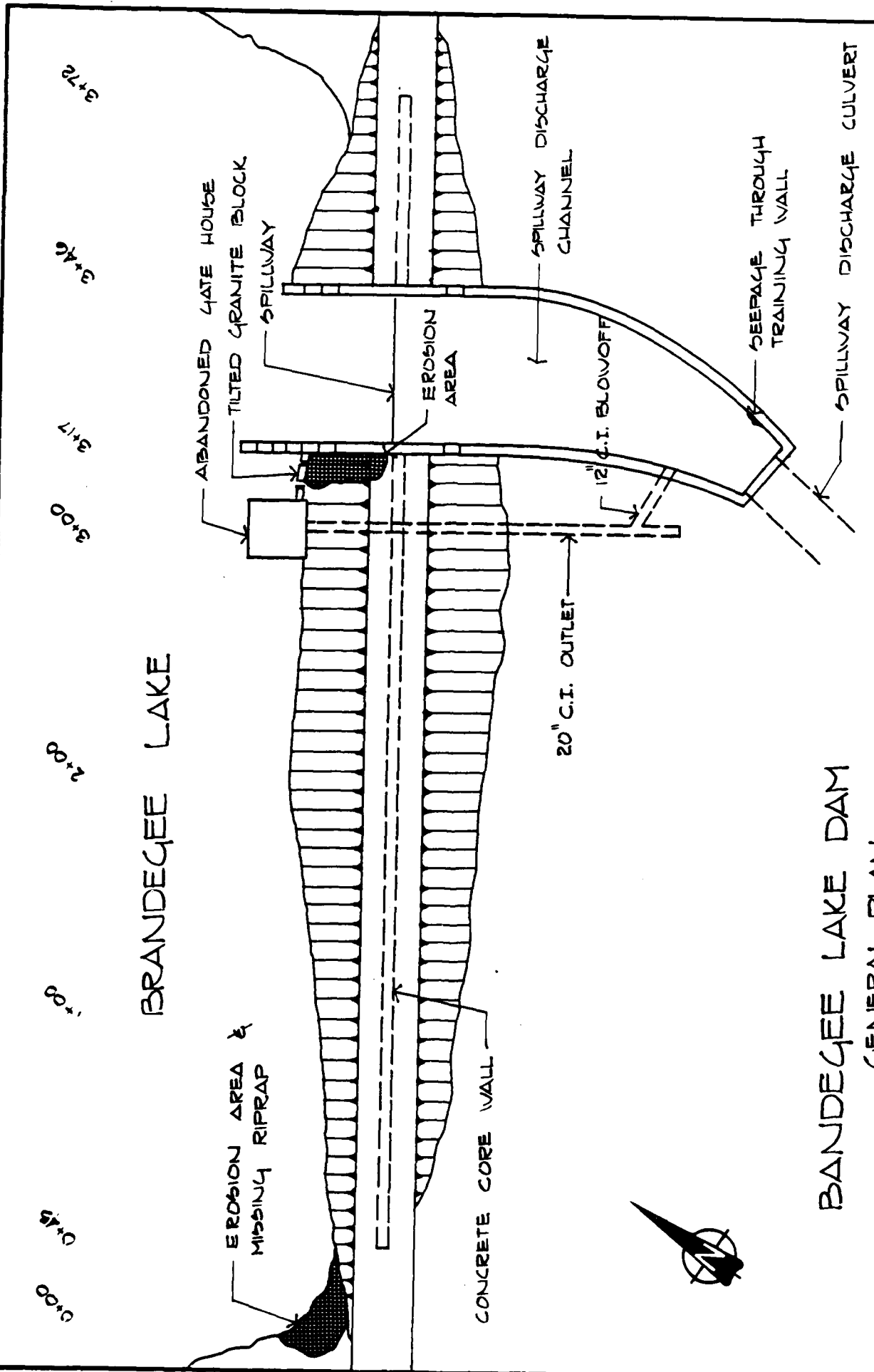

BRANDEGEE LAKE

BRANDEGEE LAKE DAM  
 GENERAL PLAN  
 NO SCALE



WATERFORD #4

No. \_\_\_\_\_

WATER RESOURCES UNIT  
SUPERVISION OF DAMS  
INVENTORY DATA

Inventoried  
By \_\_\_\_\_

Date \_\_\_\_\_

Name of Dam or Pond BRIDGEGEE LAKE DAM

Code No. \_\_\_\_\_

Nearest Street Location VAUXHALL ROAD

Town WATERFORD

U.S.G.S. Quad. D-13

Name of Stream \_\_\_\_\_

Owner TOWN OF WATERFORD

Address 200 BOSTON POST ROAD

WATERFORD, CT 06385

Pond Used For RECREATION ? Drainage Area 1.82 square mile

Dimensions of Pond: Width \_\_\_\_\_ Length \_\_\_\_\_ Area \_\_\_\_\_

Total Length of Dam 200 Length of Spillway 30

Location of Spillway SOUTHERN MOST PORTION OF THE LAKE

Height of Pond Above Stream Bed 10 feet

Height of Embankment Above Spillway 4 feet

Type of Spillway Construction GRANITE BLOCKS AND CUT GRANITE

Type of Dike Construction EARTH

Downstream Conditions SHOPPING PLAZA AND PARKING LOT

Summary of File Data \_\_\_\_\_

Remarks SHOULD THE DAM FAIL THE DOWNSTREAM CULVERT  
IS SUFFICIENT IN SIZE TO CATCH THE RESULTANT FLOOD

Would Failure Cause Damage? unlikely Class C

July 20, 1971

Donald G. Leavitt

Bureau of Highways

Kenneth N. Tedford

Assistant Attorney General

Lake Brandegee Dam, Waterford

I have spoken with Charles Pelletier, the Division Engineer for the Water Resources Division of the Water Resources Commission. I presented the problem in relation to Lake Brandegee to him. I have also read the Statutes regarding the powers and duties of the Water Resources Commission to supervise dams. Section 25-110 of the Connecticut General Statutes provides that the Water Resources Commission has the jurisdiction over all dams, dikes and reservoirs in the state. Section 25-111 provides that the Commission shall investigate and inspect all dams. Section 25-112 provides that before any person or corporation constructs, alters, adds to, replaces or removes any dam they shall apply to the Water Resources Commission for a permit to do such work. The supervision of such construction or alteration lies again with the Water Resources Commission. In speaking with Mr. Pelletier I was informed that the Water Resources Commission is concerned only with the safety of the dams in this state. They do not concern themselves with the draining of any lake except where the owner of such lake or dam intends to remove the dam, alter it or reconstruct it.

Section 26-138 of the Connecticut General Statutes provides that no person shall drain any pond or lake for any purpose without first giving notice to the Director of the State Board of Fisheries and Game at least 48 hours before such draining. The intent of this Statute is to allow the State Board of Fisheries and Game to determine whether the removal or salvage of fish would be necessary. There is no provision in this statute to allow the State Board of Fisheries and Game to prohibit the draining of a lake.

Therefore, the Water Resources Commission or the State Board of Fisheries and Game would have no authority to prohibit the City of New London from draining Lake Brandegee unless the City intended to remove the dam and then only to grant a permit under their regulations.

STATE WATER RESOURCES  
COMMISSION  
RECEIVED

JUL 21 1971

ANSWERED \_\_\_\_\_  
RECORDED \_\_\_\_\_  
FILED \_\_\_\_\_

*File and  
to Bill  
Kearney*

Mr. Donald G. Leavitt

- 2 -

July 20, 1971

I was informed by Mr. Pelletier that the Water Resources Commission has granted permission to the Department of Transportation, Bureau of Highways to pipe the stream flowing from Lake Brandegee in accordance with Section 25-4a of the General Statutes requiring the Water Resources Commission's permission for stream channel encroachment. The permission granted by the Water Resources Commission was predicated upon Lake Brandegee remaining as a lake and providing temporary storage for the water. If you need any further assistance please feel free to contact us.

---

Kenneth N. Tedford  
Assistant Attorney General  
566-5616

Approved by:

---

Jack Rubin  
Assistant Attorney General  
566-3946

KNT/pc

cc: Joseph O'Hearn, Bureau of Highways  
/Charles Pelletier, Water Resources Commission

FLOOD



**CITY OF NEW LONDON  
CONNECTICUT**

27 July 1978

State of Connecticut  
Dept. of Environmental Protection  
State Office Building  
Hartford, Connecticut

Att: Mr. Benjamin A. Warner  
Acting Director  
Water Resources Unit

Subject: Lake Brandegee Dam  
Our W. O. No. 288

Gentlemen:

All of the work on the Brandegee Dam required in your letter of 14 June 1978 has been completed. Thank you for bringing it to our attention.

Sincerely,

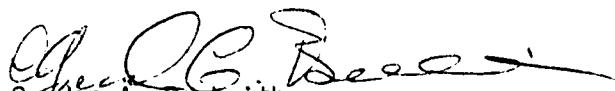
  
Gordon A. Beckwith  
Supt. Water Supply System  
epf

SEARCHED \_\_\_\_\_  
SERIALIZED \_\_\_\_\_  
INDEXED \_\_\_\_\_  
FILED \_\_\_\_\_

STATE OF CONNECTICUT  
DEPARTMENT OF ENVIRONMENTAL PROTECTION

MUNICIPAL BUILDING HARTFORD, CONNECTICUT

14 June 1978

Mr. Gordon Beckwith  
Supt. of Water & Sewer Maintenance  
Municipal Building  
181 State Street  
New London, Connecticut 06320

Re: Brandegee Lake  
Waterford

Dear Mr. Beckwith:

According to records maintained in this office, the above-mentioned dam is under your ownership.

Section 25-110 (Public Law No. 571, 1975 Revision of the General Statutes), a copy of which is enclosed, places under the jurisdiction of this department all dams, which by breaking away or otherwise, might endanger life or property. It has been determined that this dam is under our jurisdiction.

In accordance with Section 25-111 (1975 Revision of the General Statutes) this dam has been inspected. In order to maintain your dam in a safe condition, the following maintenance work or deficiencies should receive attention:

1. Brush growth on dam; especially on upstream rip rap should be cut and removed.
2. Small maple tree growing on the east abutment of spillway should be removed.
3. Eroded section of embankment between the west abutment and the gate house should be restored to original elevation.

The Water Resources Unit of the Department of Environmental Protection shall be notified within two weeks as to what steps you plan to take to accomplish this work.

If you have any questions, please contact Victor Galgowski, Supt. of Dam Maintenance, at 566-7245.

Sincerely,

Benjamin A. Warner  
Acting Director  
Water Resources Unit

BAW:1jk  
Enclosure

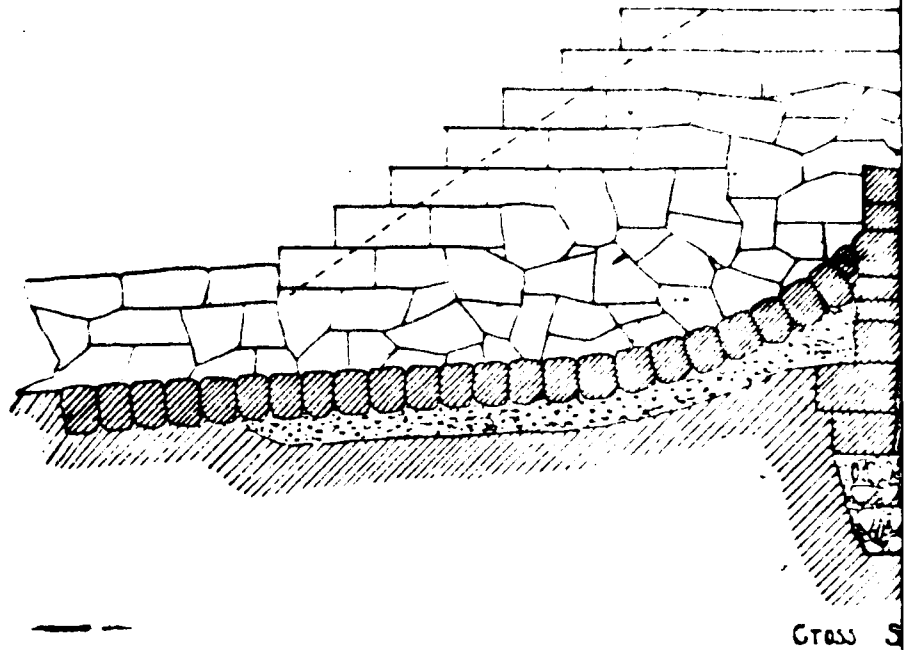

Cross Section

**NEW LONDON WATER WORKS  
BRIGGS BROOK DAM**

*John S. ...*

ENGINEER

APPROVED

*J. H. ...*

STATE BOARD OF ENGINEERS

Scale 1/2 inch = 1 foot

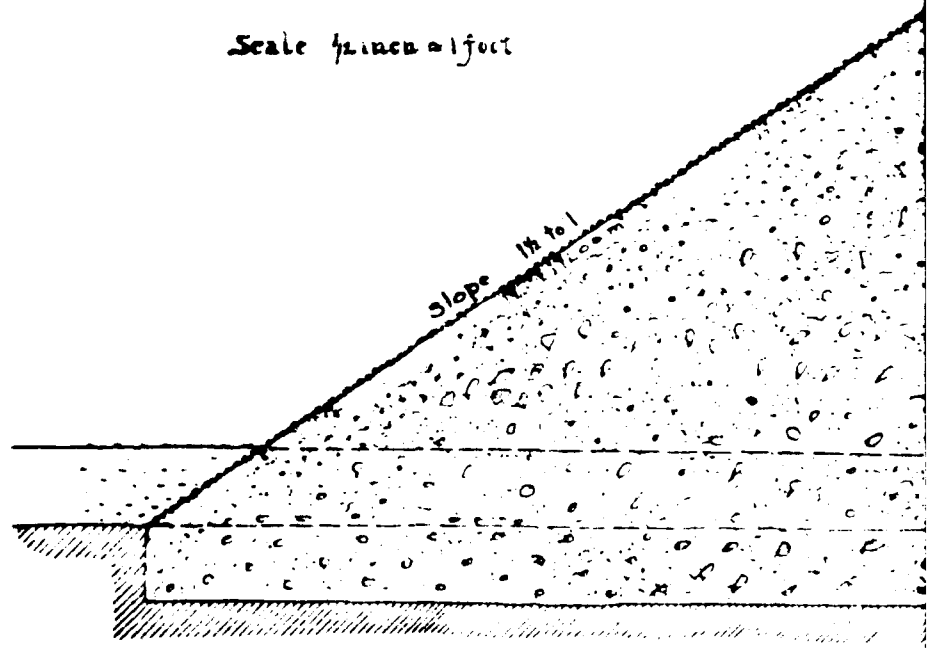

Cross Section

B  
34

(1)

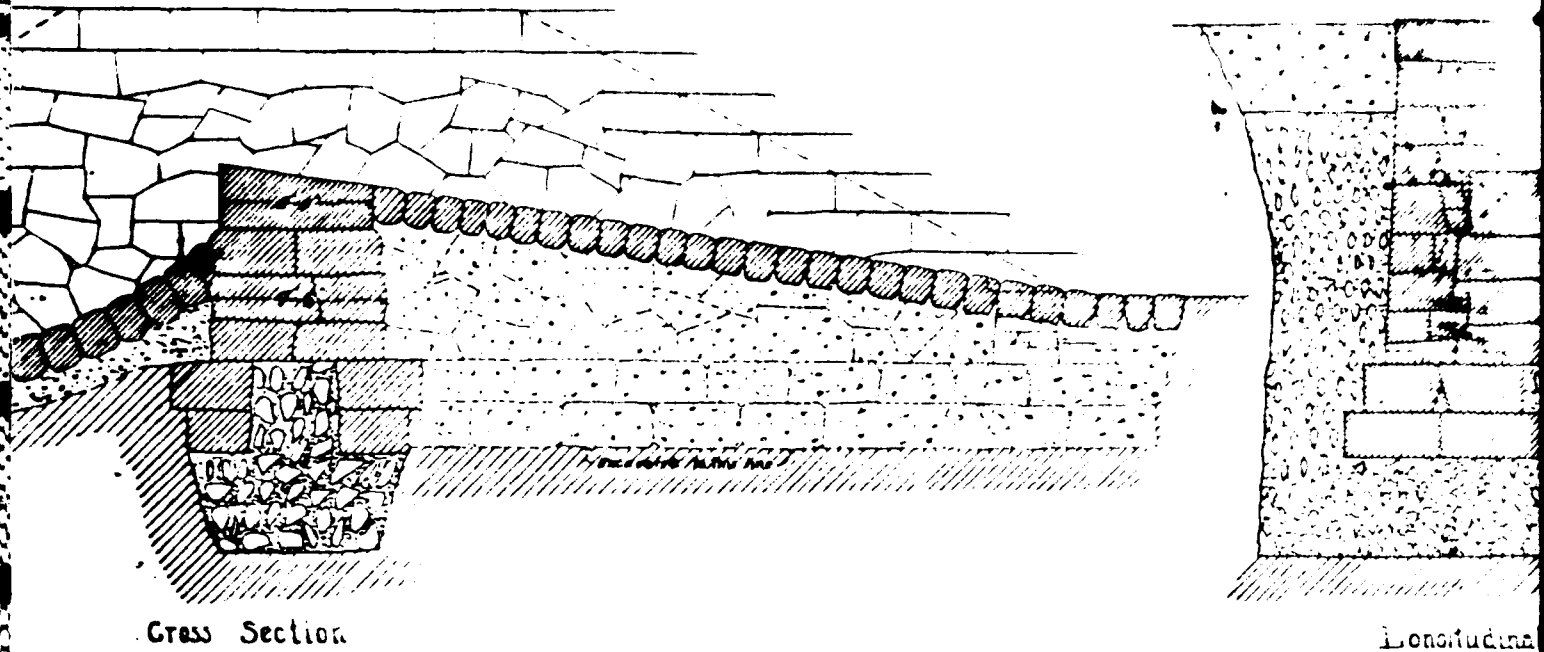

Cross Section

Longitudinal

Details of Overflow

ENGINEER

ENGINEERS

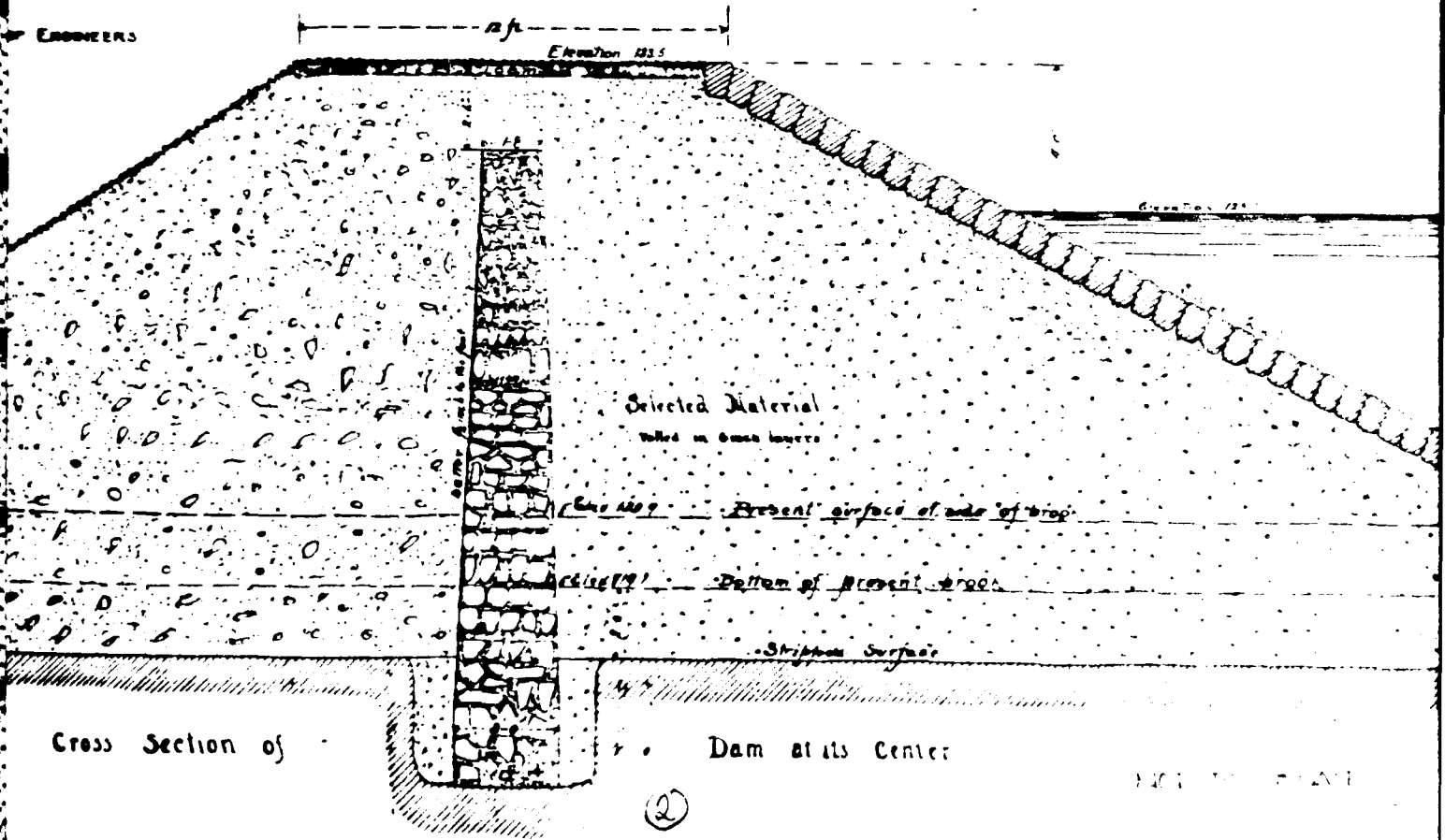

Cross Section of

Dam at its Center

2

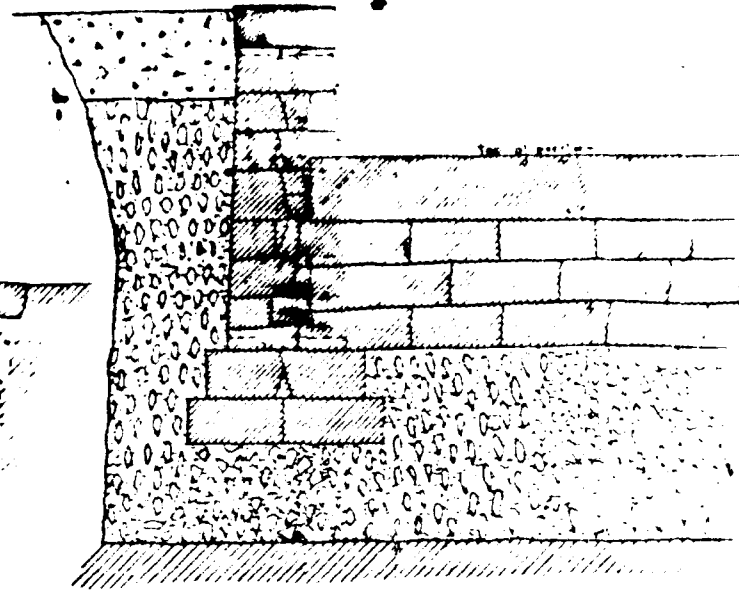

Longitudinal Section.

of Overflow

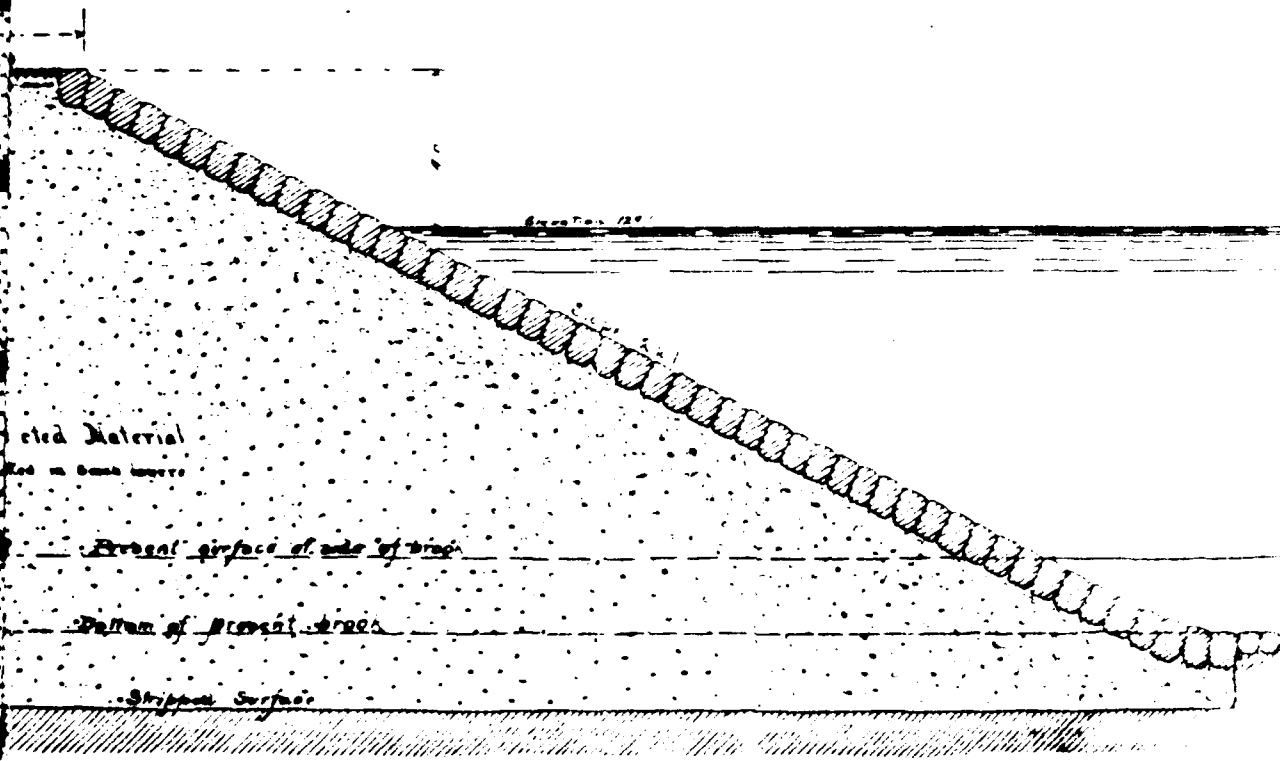

ected Material

Red in bank works

Present surface of side of drop

Bottom of present area

Stripped Surface

Dam at its Center

NOT TO SCALE

②

③

B  
34

initial  
B.S.

PREVIOUS PAGE IS BLANK



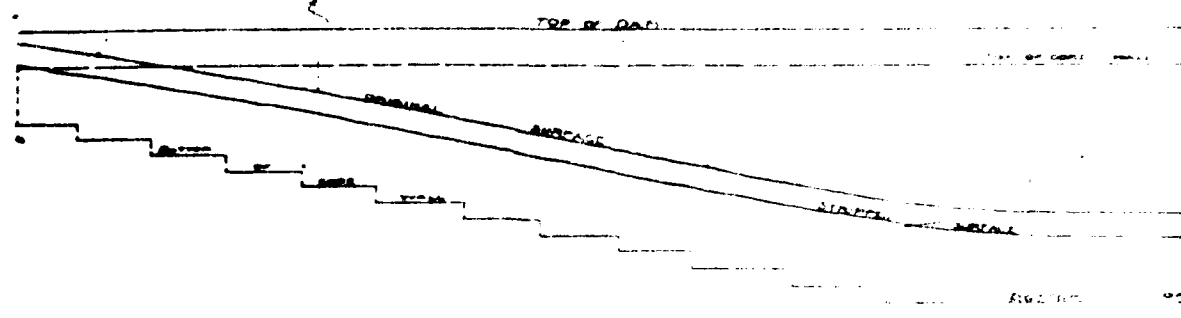

NEW LONDON WATER WORKS  
BRIGGS BROOK DAM

*[Signature]*  
ENGINEER

APPROVED

*[Signature]*  
STATE Bd OF ENGINEERS

Scale 1/8" = 1' Vertical  
1/4" = 10' Horizontal

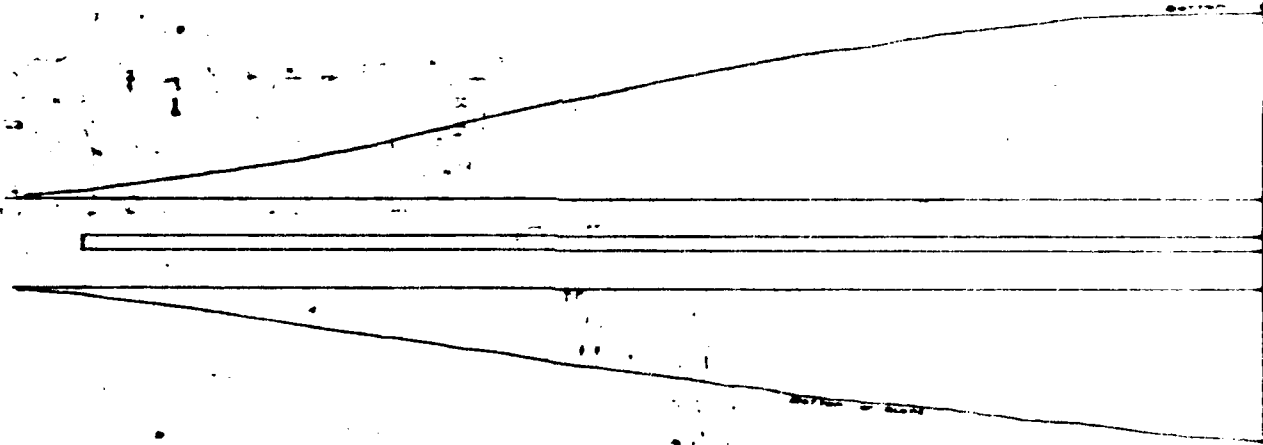

B  
36

①

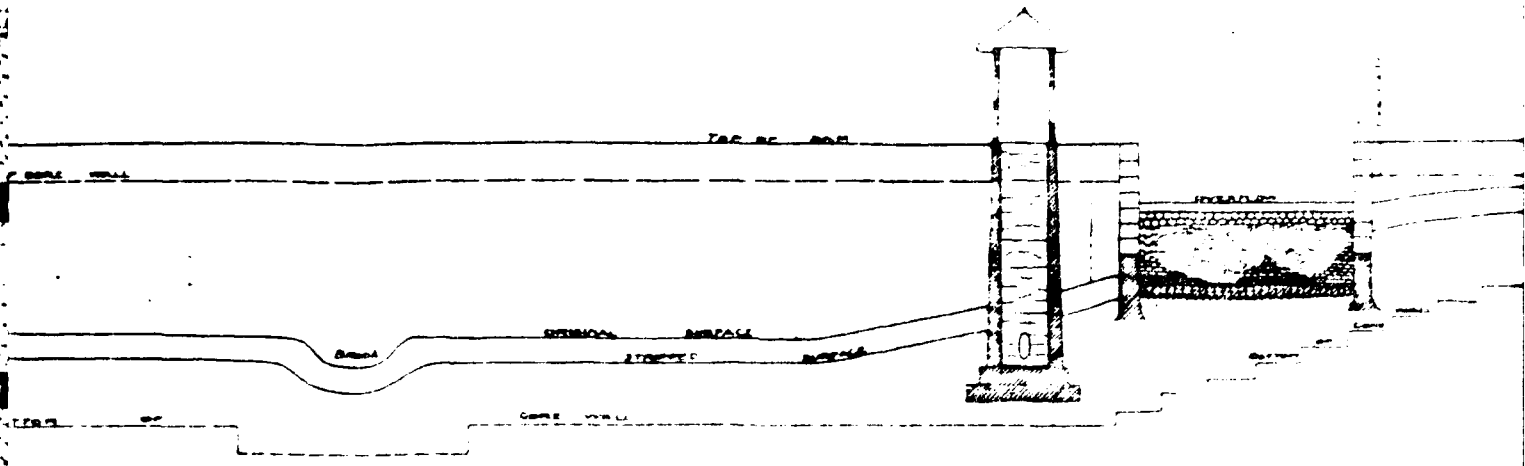

Longitudinal Section through Dam

1:5 Vertical  
1:10 Horizontal } feet = 1 inch

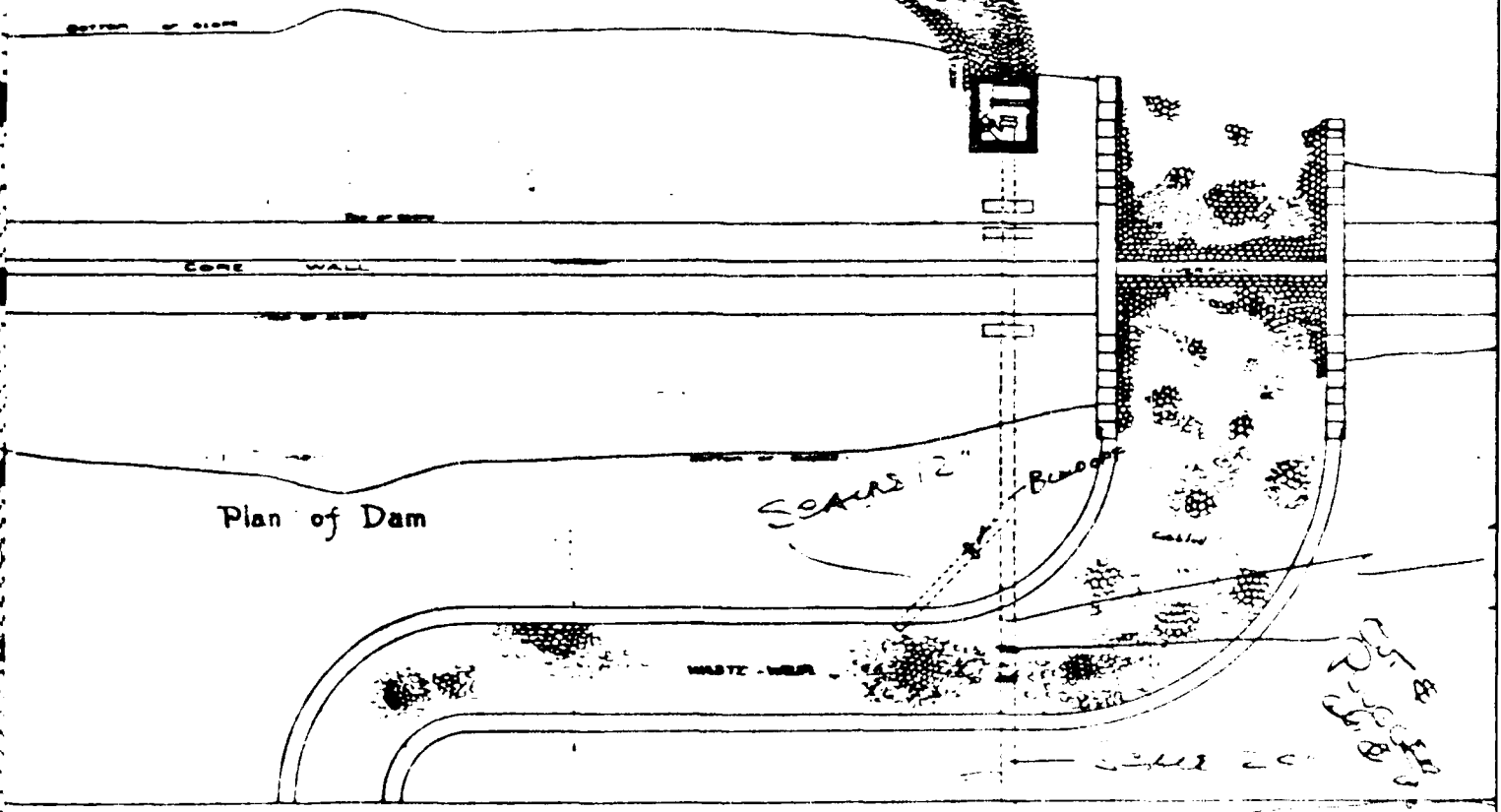

Plan of Dam

NOT TO SCALE

An 12" Pipe (unstrapped)  
Attached to pier and  
1ft

PREVIOUS PAGE  
IS BLANK



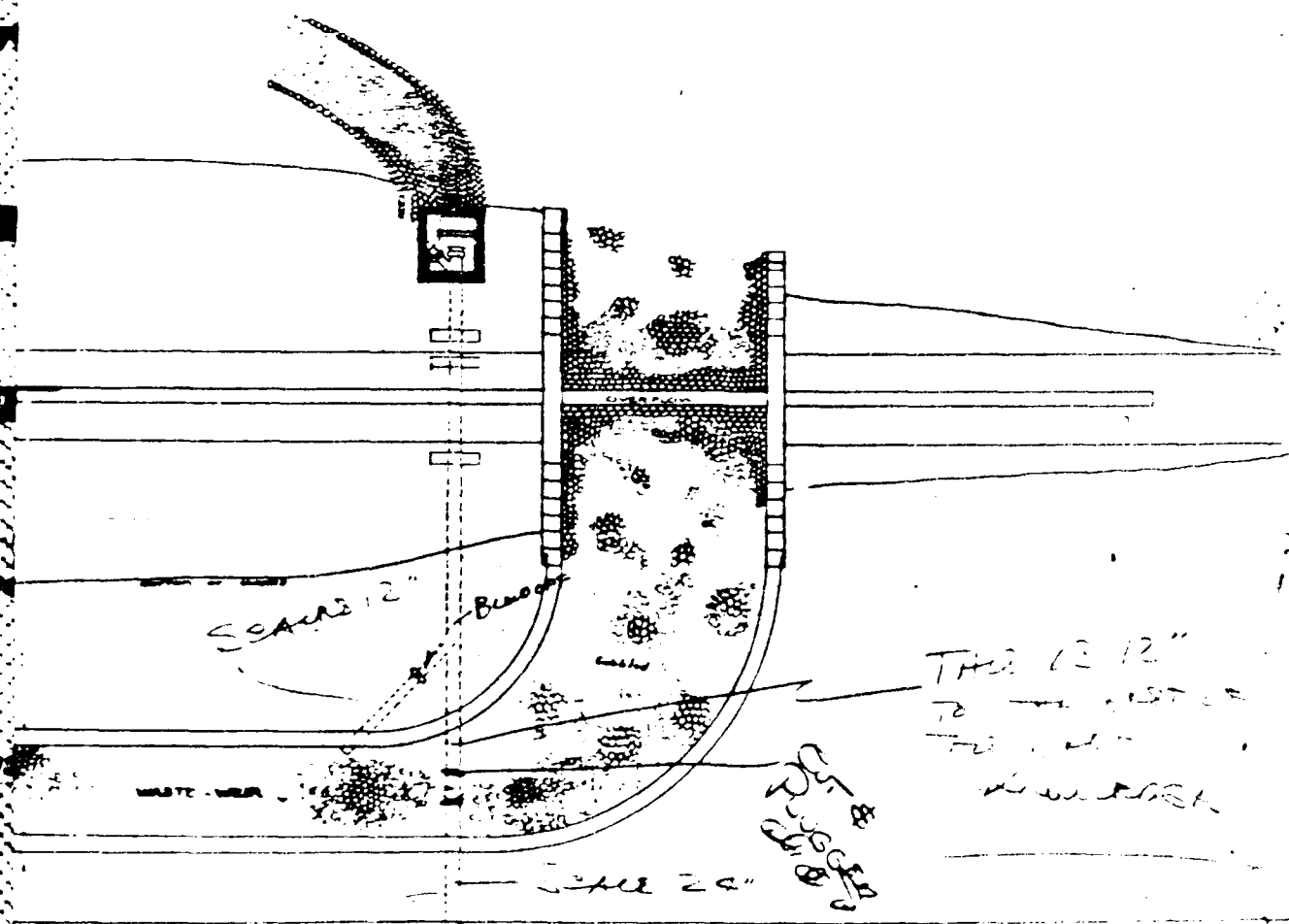
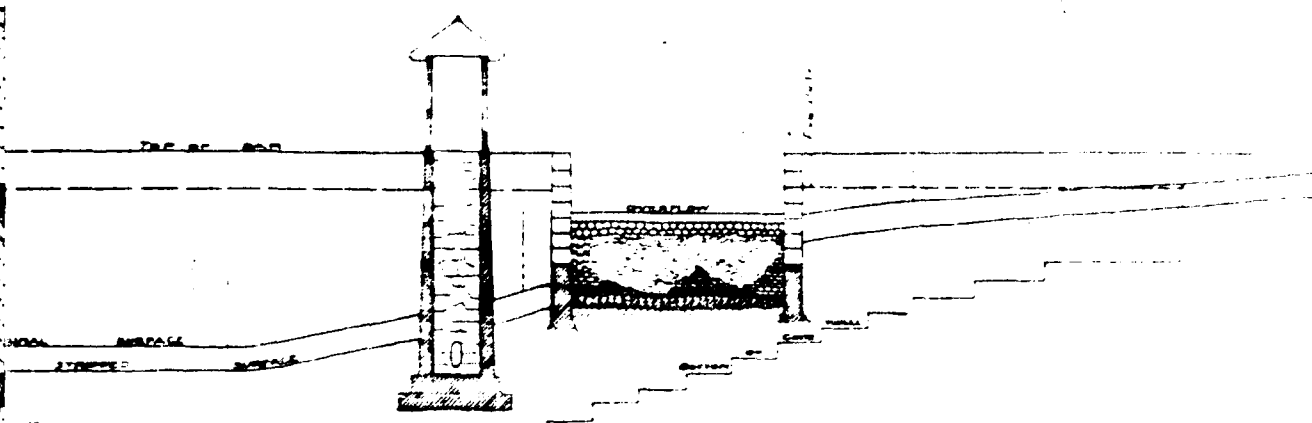

All 12" PIPE immediately abandoned in place about 1960.

NOT TO SCALE

B  
36

Robert  
1960

SECTION THROUGH GATE-CHAMBER/PIPING LINE  
ON LINE M.B.T. TRANSVERSE GRADES

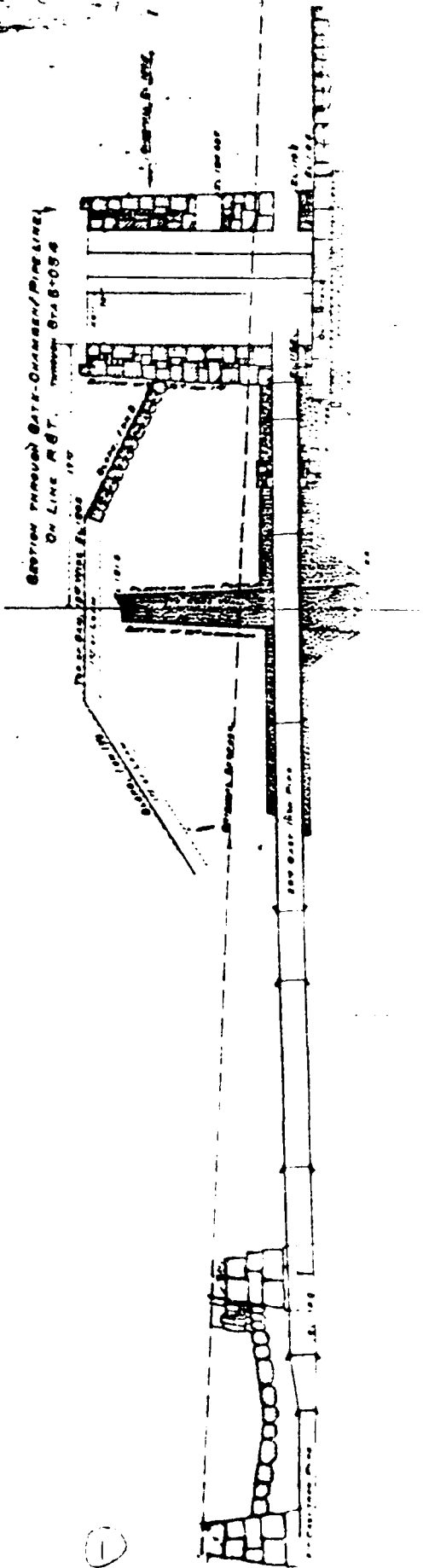

SECTION ON LINE A-B  
TRANSVERSE GRADE

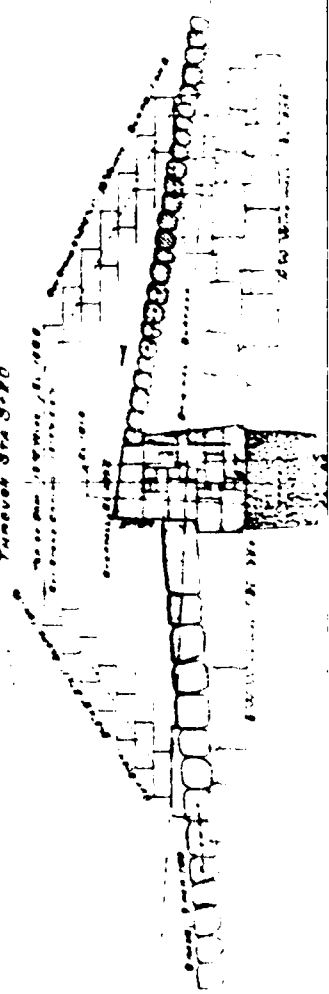

B  
39

①

SECTION THROUGH GATE-CHAMBER  
ON LINE G-H.

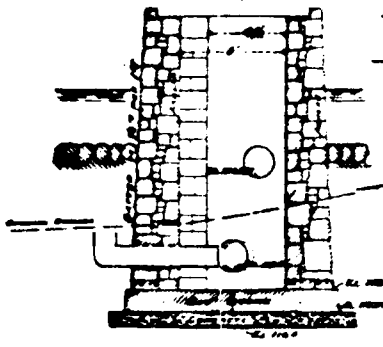

SECTION ON LINE JKLMNO  
THROUGH WHIRLWELL ON LINE OF OVERFALL.

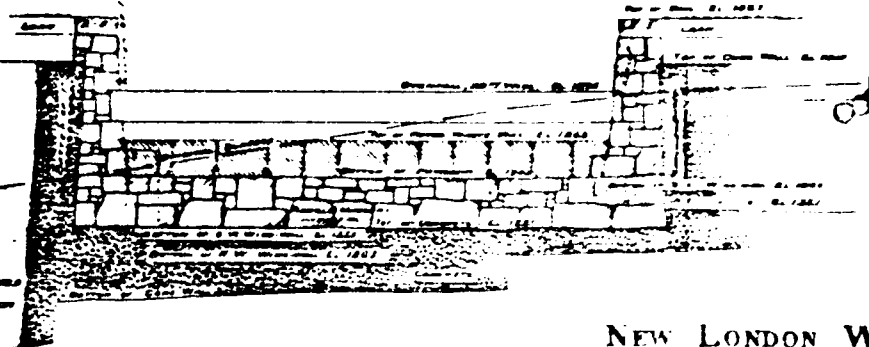

NEW LONDON W  
BRIDGE BR  
LAKE BR

As Constructed

Scale 1/2" = 1'

PLAN OF MASONRY IN  
GATE-CHAMBER, WHIRLWELL / OVERFALL

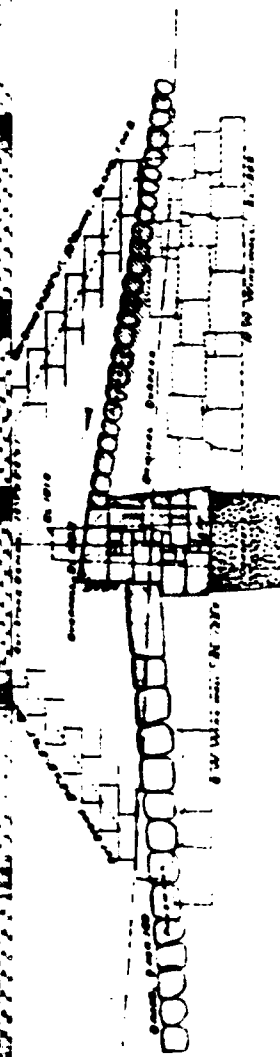
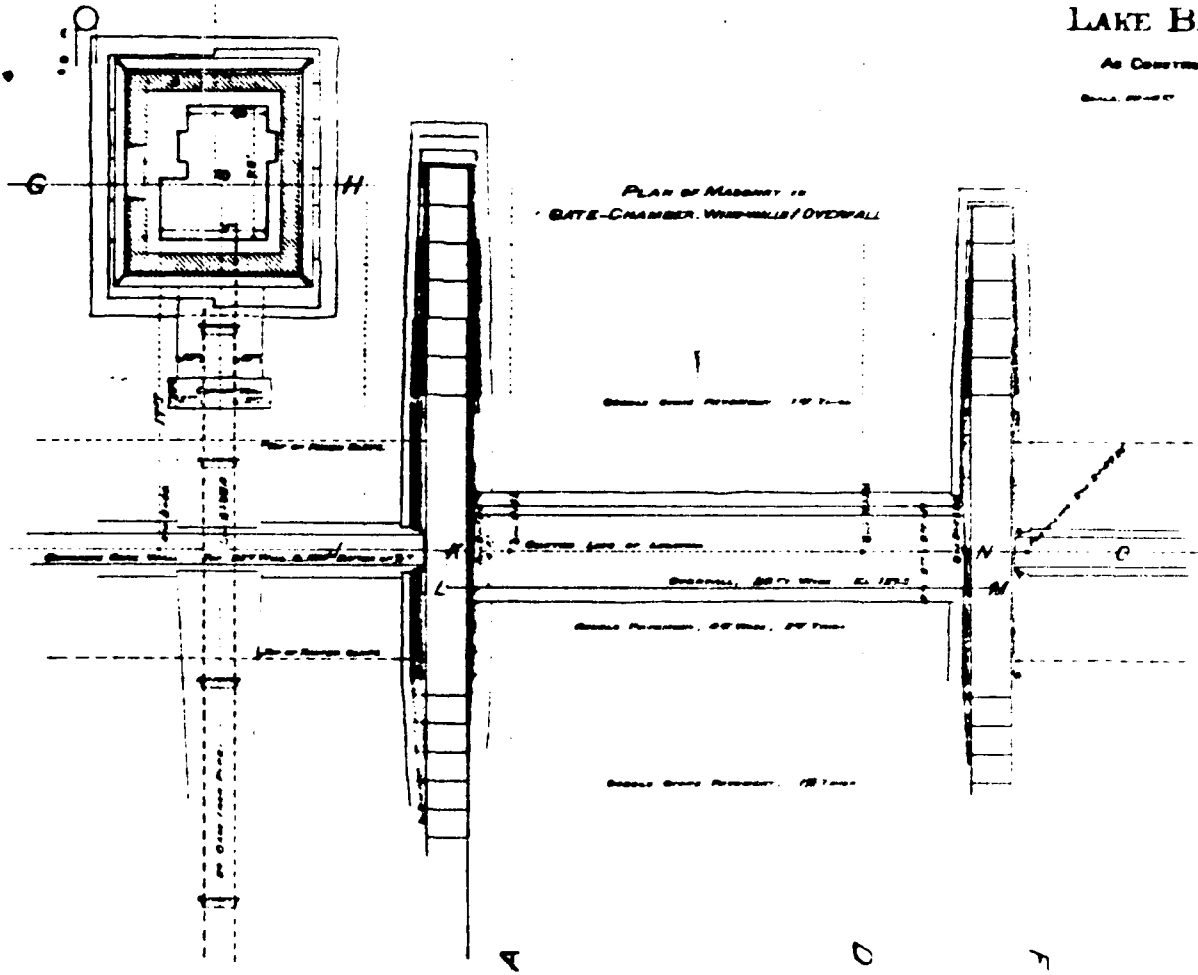

SECTION ON LINE J-K-L-M-N-O  
 Through Chamber of Line of Overfall.

SECTION ON LINE E-F  
 THROUGH STA 1150 C

NEW LONDON WATER WORKS.  
 BRIGGS BROOK DAM  
 LAKE BRANDEGEE.

As Constructed in 1897.

PLAN OF MASONRY IN  
 GATE-CHAMBER, WHIRLPOOL / OVERFALL.

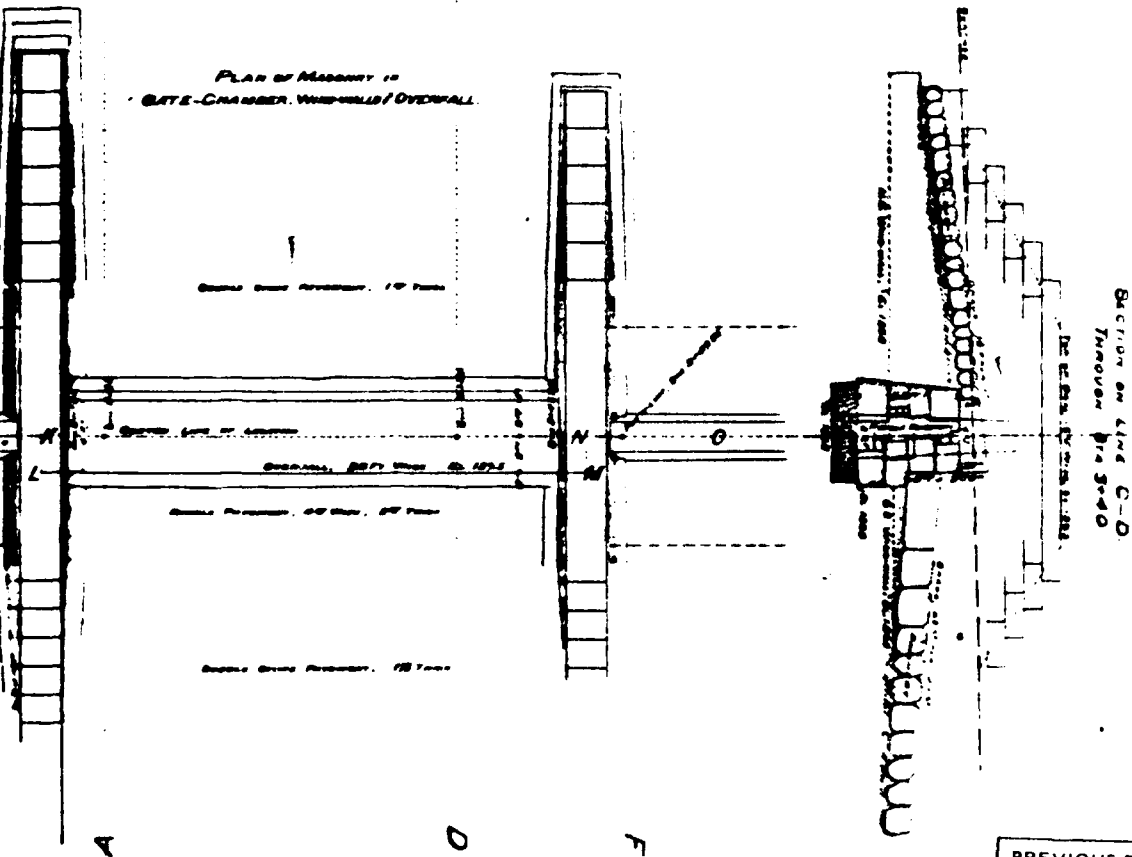

PREVIOUS PAGE IS BLANK

NOT TO SCALE

B  
 39

APPENDIX C

PHOTOGRAPHS

3+00  
3+10  
3+20  
3+30  
3+40  
3+50

# BRANDEGEE LAKE

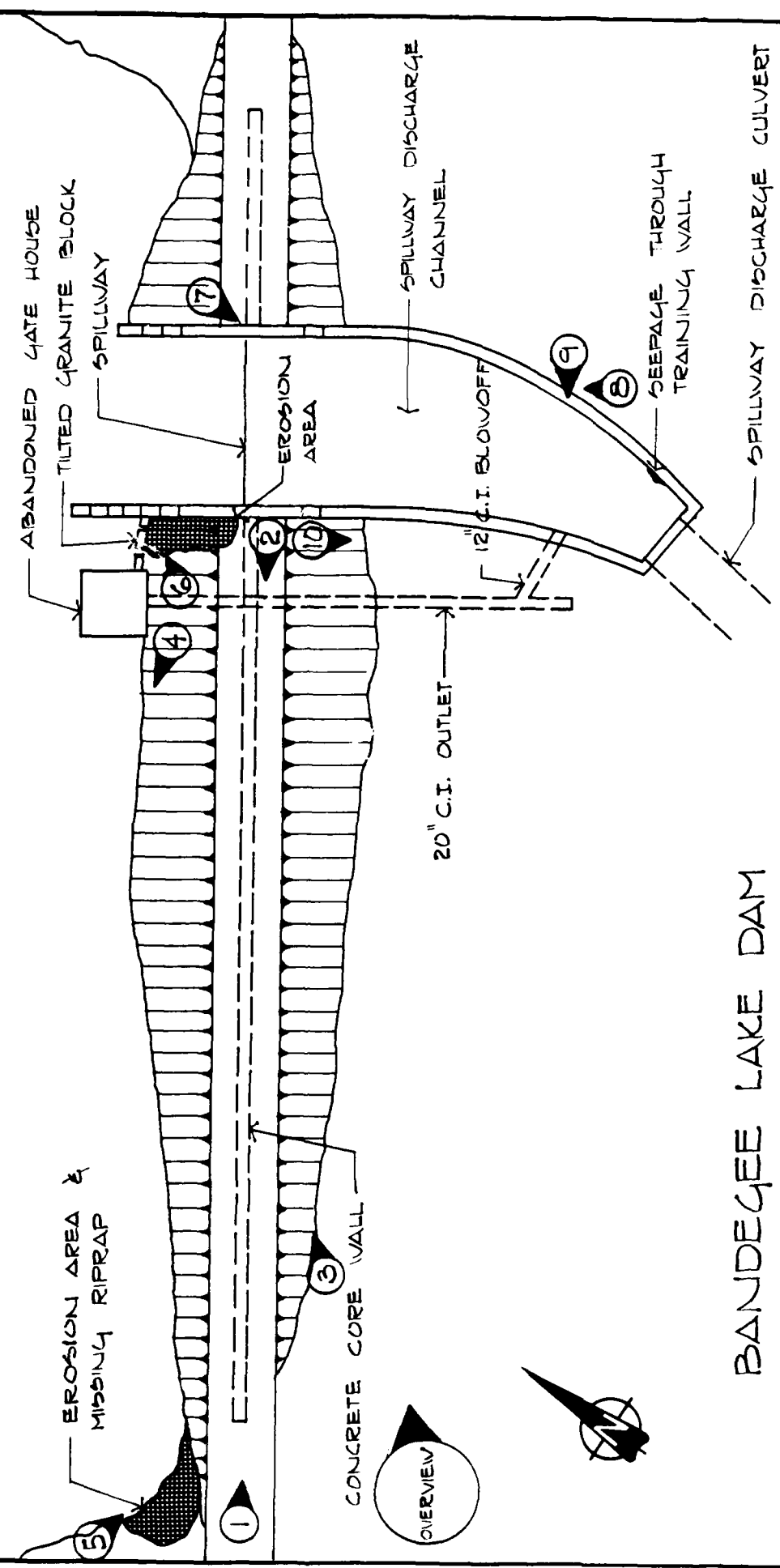

BRANDEGEE LAKE DAM  
 PHOTO INDEX  
 NO SCALE

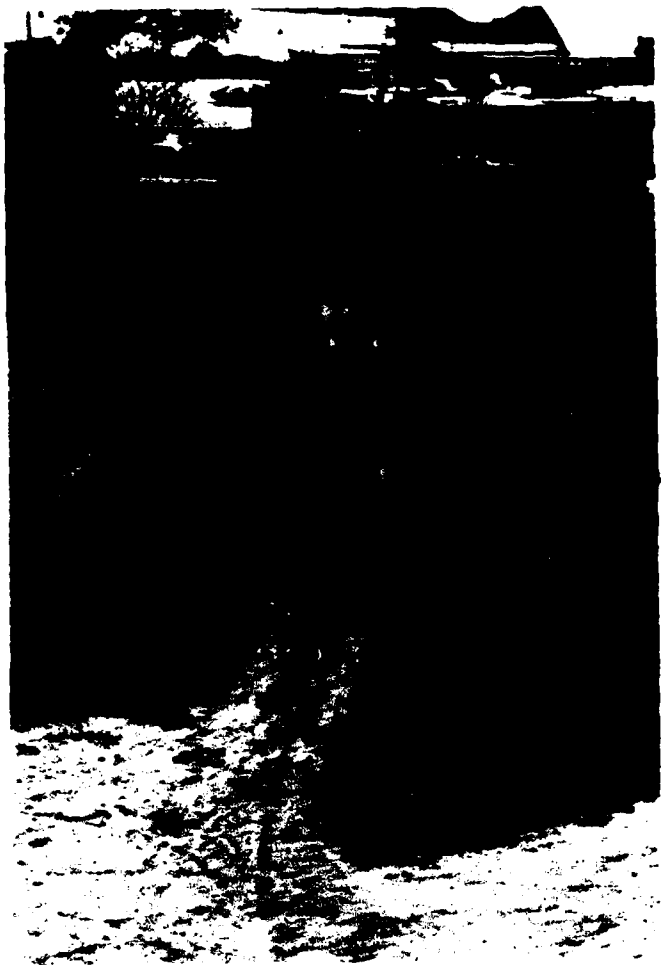

PHOTO C-1. Crest of the dam  
from the right side.



PHOTO C-2. Crest of the dam looking towards the  
right abutment.



PHOTO C-3. Downstream face from the right side showing growth of pine trees on the slope.



PHOTO C-4. Riprap on upstream face near gatehouse.



PHOTO C-5. Eroded zone on upstream face at the right abutment.

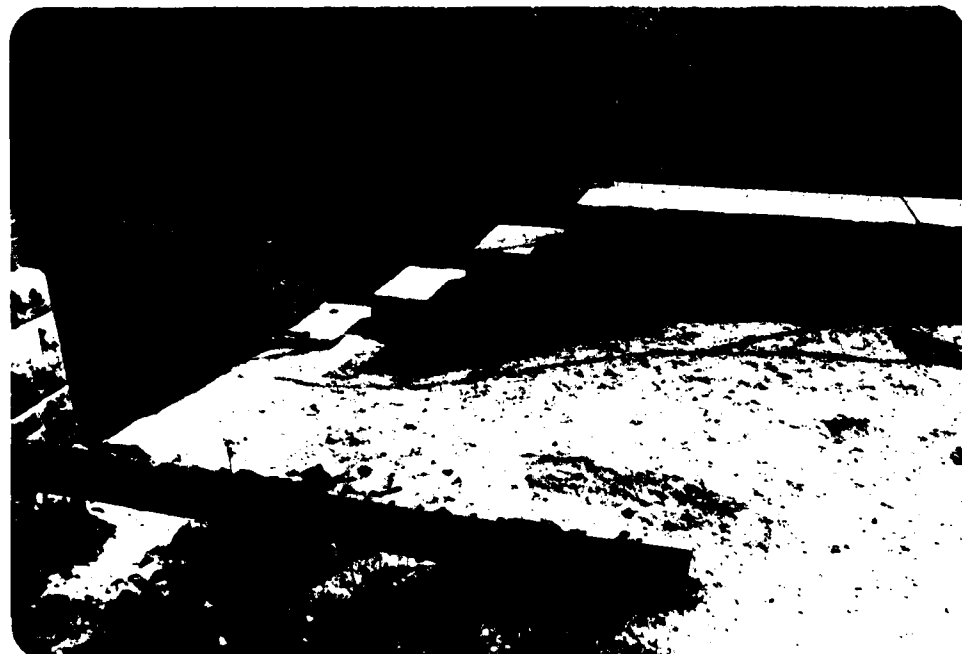

PHOTO C-6. Eroded zone of crest and upstream face at the right training wall of the spillway. Note the movement of the upstream granite blocks at the left center of the photo.



PHOTO C-7. Spillway crest, discharge channel and culvert. Seepage through the left training wall is visible as a wet area just upstream from entrance to the culvert near the floor of the channel.

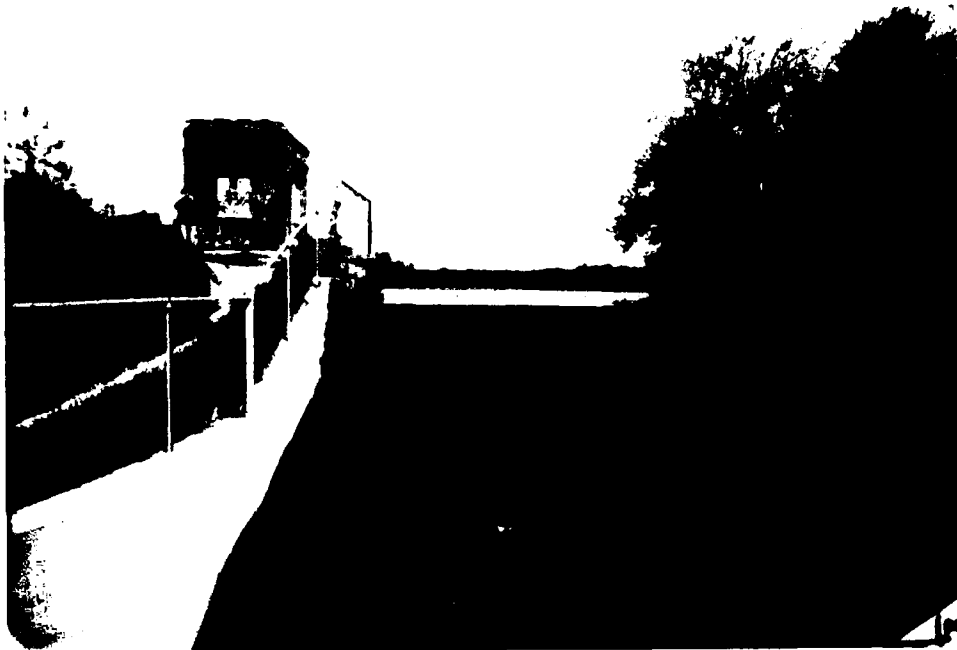

PHOTO C-8. Spillway and discharge channel from downstream. Note the vertical displacement of the construction joint in the floor of the channel.



PHOTO C-9. Outlets of pipes through right training wall of the spillway discharge channel. The pipe on the right is assumed to be the outlet of the low level outlet. Note the seepage through and around the pipes.



PHOTO C-10. Downstream area below dam with spillway discharge channel in the foreground. Note the two parking lots and Route 95 Fontage Road which are located in the dam failure impact area.

APPENDIX D

HYDROLOGIC AND HYDRAULIC COMPUTATIONS

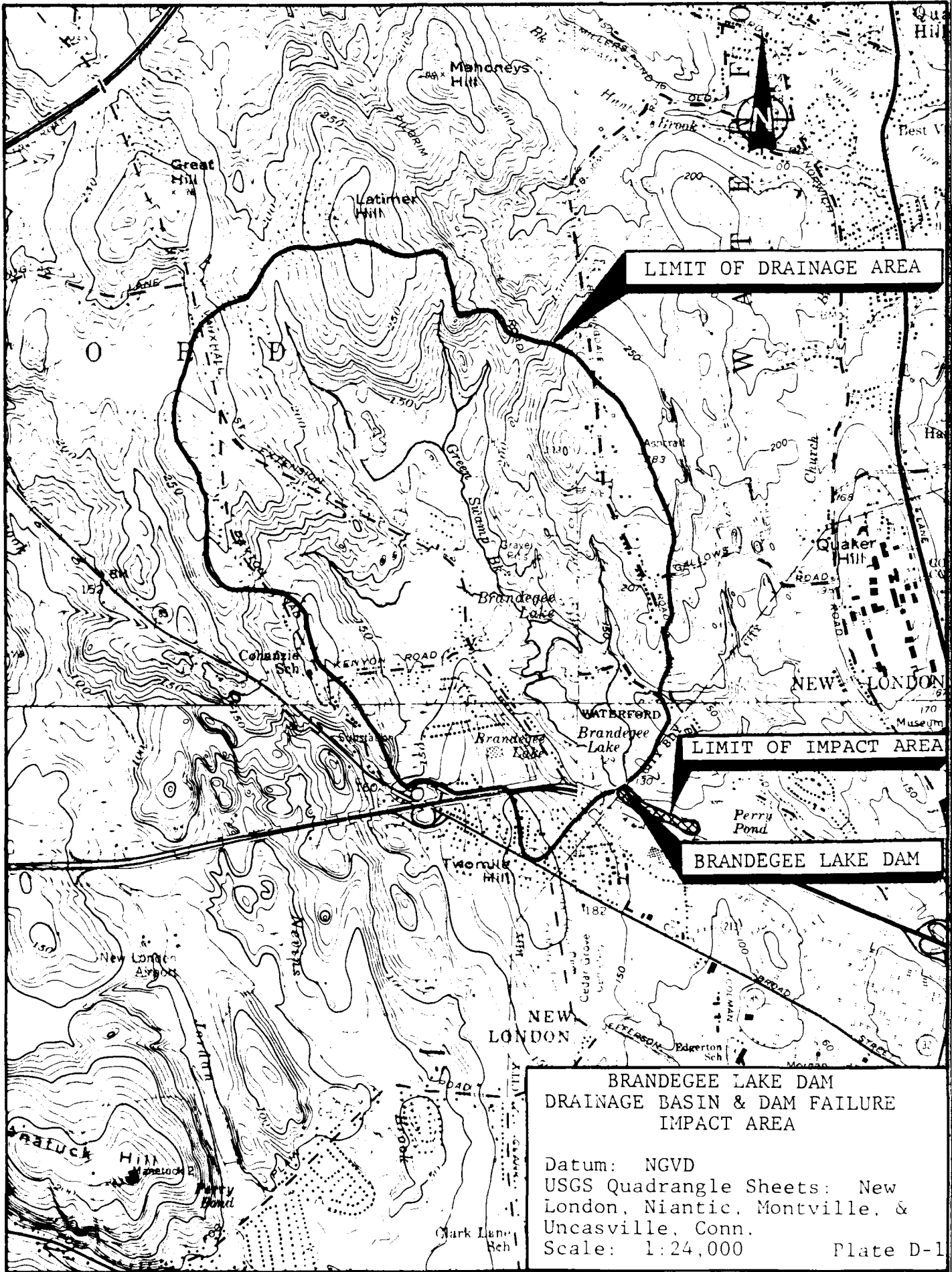

Job No. 910163 GRAVEEGEE LAKE DAM Sheet 1 of 3  
Project DAM DESIGN Date 5/25/87  
Subject HYDROLOGIC & DESIGN By RS Ch'k. by \_\_\_\_\_

### BASIC DATA

DRAINAGE AREA = 1.80 SQ. MI  
SPILLWAY POOL ELEV. = 129.5 NGVD  
MAX. POOL ELEV. = 133.5 NGVD

### RESERVOIR

@ SPILLWAY POOL - AREA = 45 AC  
STORAGE = 350 AC-FT

@ MAX. POOL - AREA = 45 AC  
STORAGE = 530 AC-FT

DAM : EARTH EMBANKMENT W/ CONCRETE COREWALL  
MAX HEIGHT : 15 FT  
LENGTH : 450 FT

SPILLWAY : STONE MASONRY, BROADCRESTED, FREE-OVERFLOW WEIR  
CREST = 129.5  
LENGTH = 28 FT

OUTLET : 12" DIA. CAST IRON PIPE  
INVERT = 117.93  
GATE : MAN. OPERATED GATE VALVE (INOPERABLE)

Job No. 21063 BRANDEGES LAKE DAM Sheet 2 of 8  
Project \_\_\_\_\_ Date 5/27/91  
Subject \_\_\_\_\_ By NC Ch'k. by \_\_\_\_\_

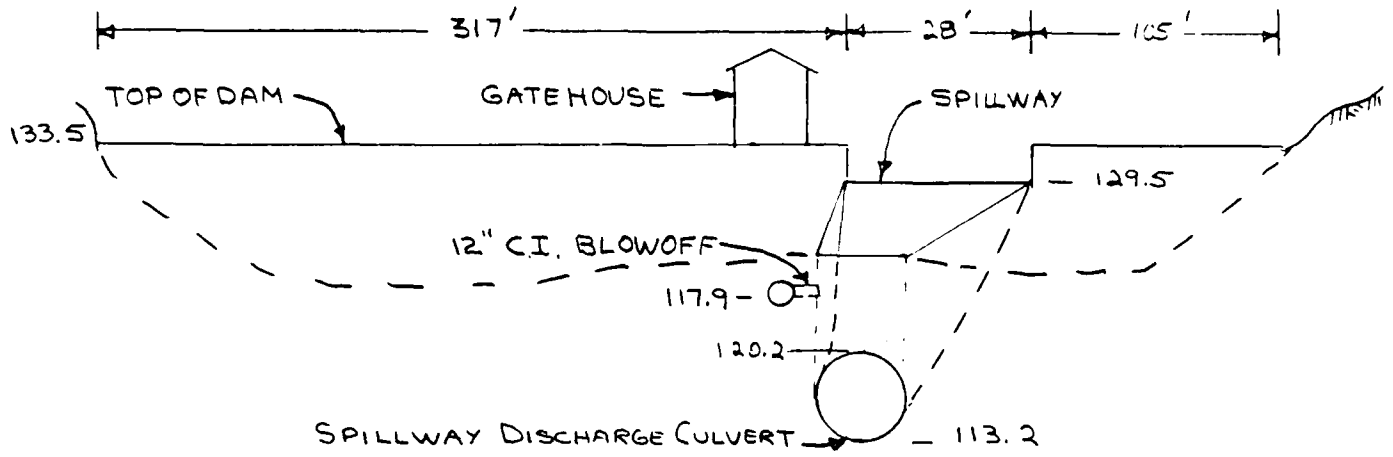

LONGITUDINAL SECTION THRU DAM - LOOKING UPSTREAM

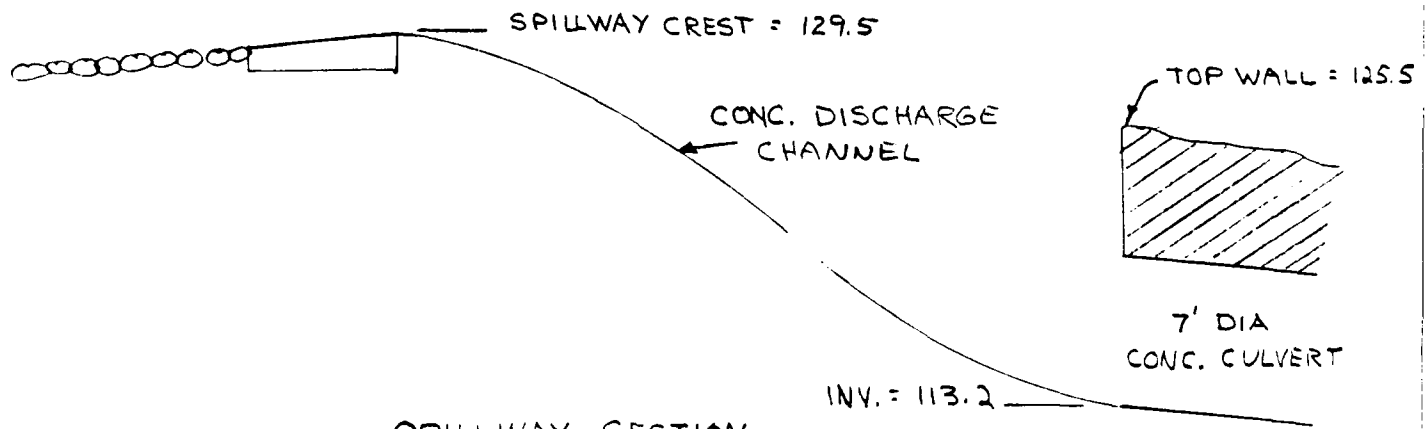

SPILLWAY SECTION

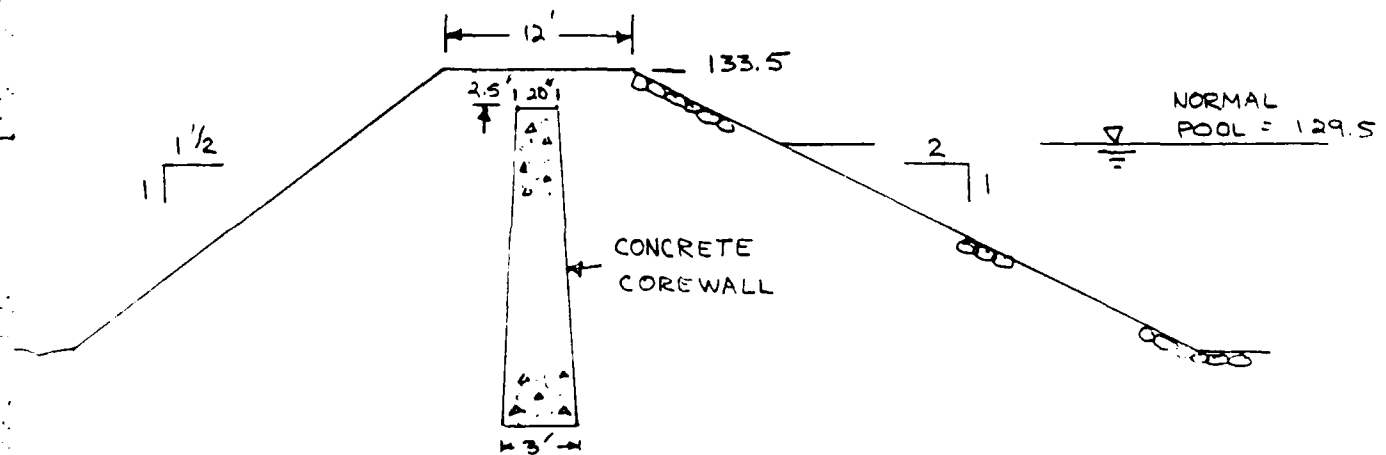

SECTION @ 2+25

Job No. 81063 BRIDGESEE LAKE DAM Sheet 3 of 2  
 Project \_\_\_\_\_ Date 2/1/61  
 Subject \_\_\_\_\_ By SS Ch'k. by \_\_\_\_\_

CALCULATE TEST FLOOD

CLASSIFICATION: SMALL  
 HAZZARD: SIGNIFICANT

USE: 1/2 PMF BASIN SLOPE = FLAT TO MODERATE  
 FROM PMF CURVE, PMF = 1500 CSM; REDUCE BY 20%  
 FOR STORAGE

$PMF = 1500 \times .8 = 1200 \text{ CSM}$

$1/2 \text{ PMF} = 600 \text{ CSM} \times 1.80 \text{ SQ MI}$   
 $= 1080 \text{ CFS} = \text{TEST FLOOD}$

CALCULATE DAM RATING CURVE

SPILLWAY  $Q = CLH^{3/2}$   $C = 3.5 = \text{TRAPEZOIDAL WEIR}$  DAM  $C = 2.6$   
 SPILL.  $L = 28'$  DAM  $L = 422'$  OUTLET IS INOPERABLE

<u>ELEV.</u>	<u>H<sub>SPILL</sub></u>	<u>Q<sub>SPILL</sub></u>	<u>H<sub>DAM</sub></u>	<u>Q<sub>DAM</sub></u>	<u>Σ Q</u>
129.5	-	-	-	-	-
130.5	1.0	100	-	-	100
131.5	2.0	280	-	-	280
132.5	3.0	510	-	-	510
133.5	4.0	785	-	-	785
134.0	4.5	935	0.5	390	1325
134.5	5.0	1095	1.0	1100	2195

@ TOP OF DAM = 133.5

SPILLWAY CAPACITY = CFS

@ TEST FLOOD = 133.7

SPILLWAY CAPACITY = 945 CFS

TOTAL PROJECT DISCHARGE = 930 CFS

BRANDEGEE LAKE DAM  
DISCHARGE RATING CURVE

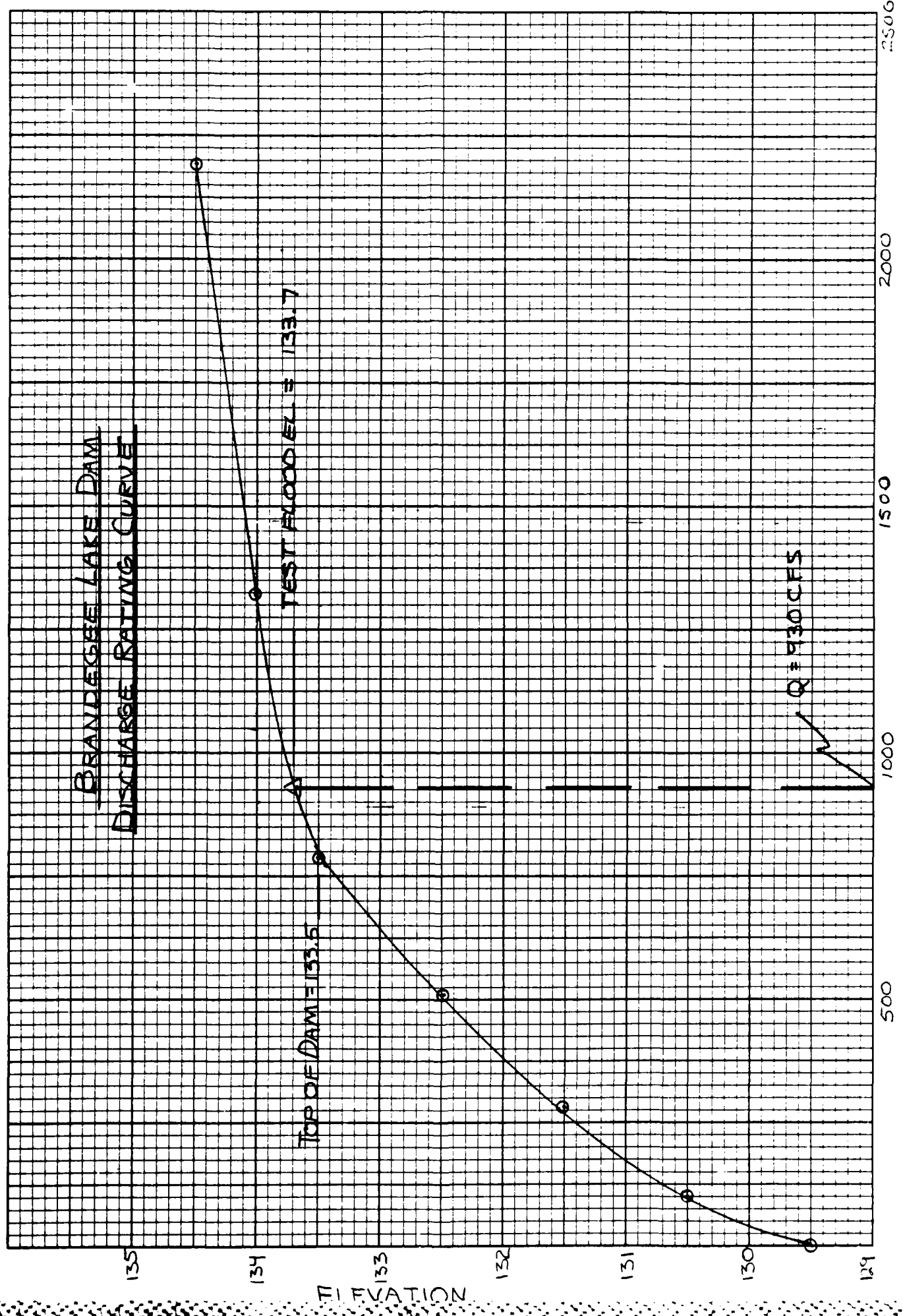

ELEVATION

DISCHARGE

TEST FLOOD EL = 133.7

TOP OF DAM = 133.5

Q = 930 CFS

Job No. 91063 BRANDEGEE LAKE DAM Sheet 5 of 8  
 Project \_\_\_\_\_ Date 9/27/21  
 Subject \_\_\_\_\_ By DS Ch'k. by \_\_\_\_\_

### CALCULATE EFFECT OF SURCHARGE STORAGE

PEAK INFLOW = 1080 CFS → SURCHARGE = 4.4 FT

$$V_1 = \frac{4.4 \times 45 \text{ AC} \times 12}{2.8 \times 640} = 1.33 \text{ IN.}$$

$$Q_{P1} = \left(1 - \frac{1.33}{9.5}\right) 1080 = 930 \text{ CFS} \rightarrow \text{SURCHARGE} = 4.2 \text{ FT}$$

$$V_2 = \frac{4.2 \times 45 \times 12}{2.8 \times 640} = 1.27 \text{ IN.} \quad V_{\text{AVG}} = \frac{1.33 + 1.27}{2} = 1.30$$

$$Q_{P2} = \left(1 - \frac{1.30}{9.5}\right) 1080 = 930 \checkmark$$

1. SURCHARGE STORAGE WILL REDUCE THE TEST FLOOD INFLOW BY 150 CFS OR 14 %
2. THE SPILLWAY CAN PASS 785 CFS OR 82 % OF THE TEST FLOOD OUTFLOW
3. AT THE TEST FLOOD DISCHARGE OF 930 CFS, THE DAM WILL BE OVERTOPPED BY 0.2 FT.

### DAM FAILURE ANALYSIS

BASED ON DAM X-SECTION, DS HAZZARD, SELECT BREACH WIDTH = 30 FT OR 15 % OF DAM WIDTH @ MID-HEIGHT (SPILL. NOT INCL.)

$$\begin{aligned} Q_{\text{FAIL}} &= 8/27 W_B \sqrt{g} Y_0^{1.5} & W_B &= 30 \text{ FT} & Y_0 &= 8 \text{ FT} \\ &= 8/27 \cdot 30 \sqrt{32.2} \cdot 8^{1.5} \\ &= \underline{1140 \text{ CFS}} \end{aligned}$$

SPILLWAY WILL CONTINUE TO DISCHARGE FLOW TO CULVERT DURING FAILURE

### ESTIMATE DOWNSTREAM IMPACT

PRIMARY IMPACT AREA IS FROM THE DAM TO PERRY FOND ± 1500 FT DOWNSTREAM. 2 SHOPPING CENTER PARKING LOTS AND THE ROUTE 95 FRONTAGE ROAD ARE LOCATED IN THE IMPACT AREA.

Job No. 81063 BRAUNDEGES LAKE DAM Sheet 6 of 8  
 Project \_\_\_\_\_ Date 5/27/91  
 Subject \_\_\_\_\_ By \_\_\_\_\_ Ch'k. by \_\_\_\_\_

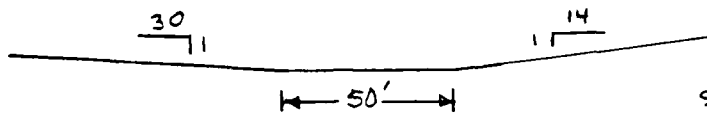

S = 0.07  
 n = 0.020

TYPICAL D.S. SECTION  
 (2<sup>ND</sup> PARKING LOT D.S.)

ESTABLISH D.S. RATING CURVE

STAGE	A	R <sup>2/3</sup>	Q
1.0	72	.83	1176

DEPTH OF FLOW = 1 FOOT @ Q<sub>FAIL</sub> = 1130  
 VELOCITY =  $\frac{1140}{72} = 15.8$  FT/SEC

MAX FLOODING IMMEDIATELY D.S. OF DAM. =  $\frac{4}{9} Y_0 = \frac{4}{9} (8)$   
 = 3.5 FT

CHECK CAPACITY OF 84" CULVERT FOR PREFAILURE FLOODING

ASSUME PRESSURE FLOW

H = 35' (U.S. TOP WALL @ CULV. - D.S. CROWN OF CULV.)

$$Q = A \sqrt{\frac{2gH}{K}}$$

$$= 38.5 \sqrt{\frac{64.4(35)}{5.67}}$$

$$= 770 \text{ CFS}$$

$$K = \frac{29.1 n^2 L}{R^{4/3}} + 1 \quad \text{FOR LONG CULVERTS}$$

L = 1500 FT    A = 38.5    R = 1.75    n = 0.015

$$K = \frac{29.1 (0.015)^2 1500}{1.75^{4/3}} + 1 = 5.67$$

REMAINING SPILL. DISCHARGE OF 120 CFS WILL FLOW AS SHEET FLOW OVER PARKING LOT (LESS THAN .5 FT DEEP)

SUMMARY

1. FAILURE FLOODING WILL INCREASE 1-2 FT OVER PREFAILURE FLOODING IN A PORTION OF PARKING LOT 100 FT D.S. OF DAM
2. FAILURE FLOODING WILL BE ± 1 FT. DEEP IN FRONTAGE RD & PARKING LOT FURTHER D.S.

550

500

450

400

350

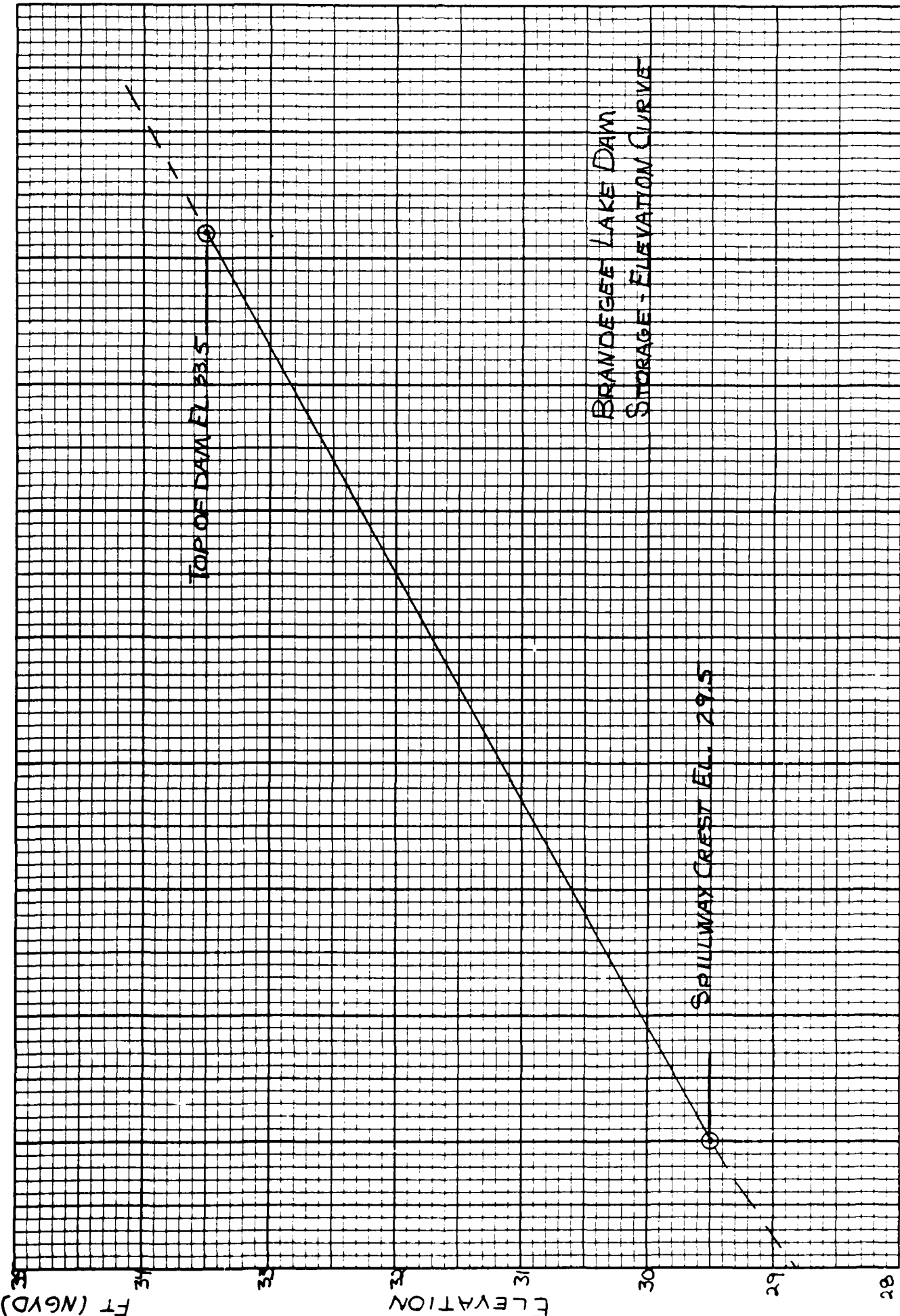

BRANDEGEE LAKE DAM  
STORAGE - ELEVATION CURVE

TOP OF DAM ELEV. 33.5

SPILLWAY CREST ELEV. 29.5

FT (NGVD)

ELEVATION

28

29

30

31

32

33

34

350

400

450

500

550

BRANDIESSÉ LAKE DAM  
DAM FAILURE PROFILE

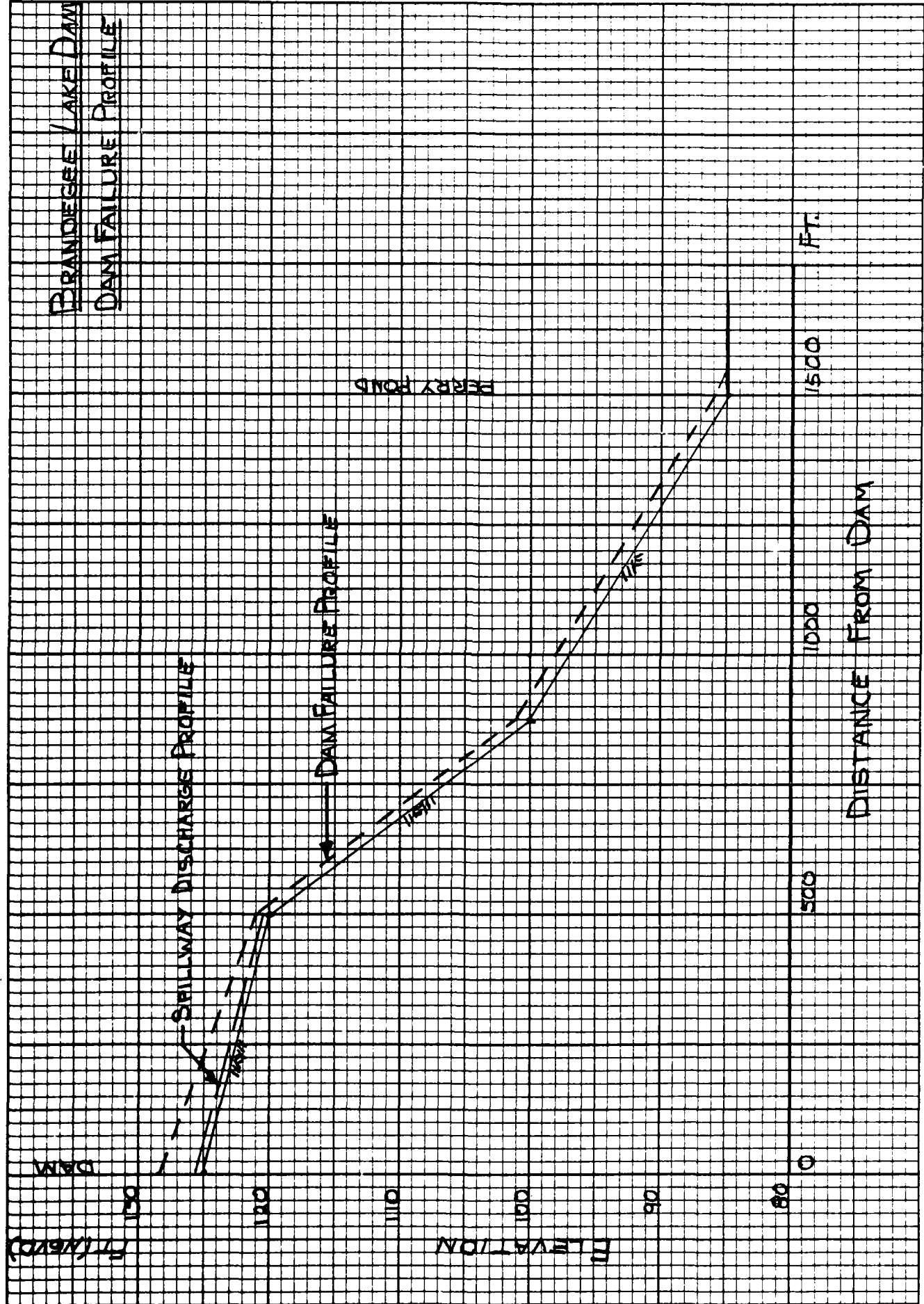

DISTANCE FROM DAM

FT.

ELEVATION

FT. (ABOVE)

RAILWAY DISCHARGE PROFILE

DAM FAILURE PROFILE

FERRY POND

DAM

APPENDIX E

INFORMATION AS CONTAINED IN THE NATIONAL  
INVENTORY OF DAMS

NOT AVAILABLE AT THIS TIME