

AD-A143 575

RADIO FREQUENCY DISTRIBUTION ASSEMBLY(U) SPERRY
GYROSCOPE CLEARWATER FL K M CULLEY 1984
N00014-82-C-2147

1/1

UNCLASSIFIED

F/G 9/5

NL

						END							
						FILED							
						...							
						DTIC							

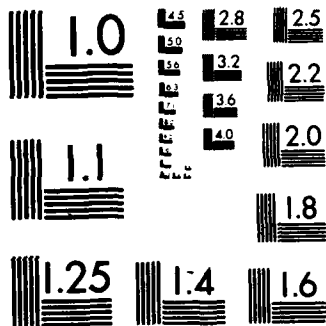

MICROCOPY RESOLUTION TEST CHART
 NATIONAL BUREAU OF STANDARDS-1963-A

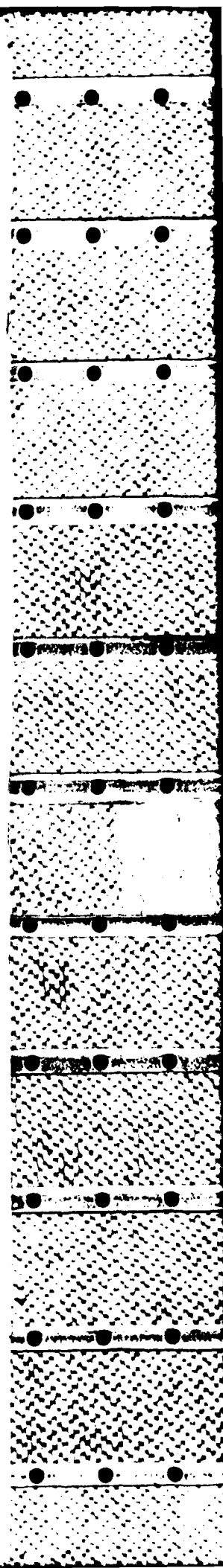

②

AD-A143 575

TECHNICAL REPORT

RADIO

FREQUENCY

DISTRIBUTION

ASSEMBLY

DTIC FILE COPY

CONTRACT NO. N00014-82-C-2147

 **SPERRY**

This document has been approved for public release and sale; its distribution is unlimited.

PREPARED BY:
KENNETH M. CULLEY

DTIC
SEL
S
JUL 27 1984
A A

84 07 25 080

TECHNICAL REPORT

R ADIO

F REQUENCY

D ISTRIBUTION

A SSEMBLY

CONTRACT NO. N00014-82-C-2147

 **SPERRY** *Gyrator
Character FL*

PREPARED BY:
KENNETH M. CULLEY

TABLE OF CONTENTS

SECTION/ PARAGRAPH	TITLE	PAGE
1.0	INTRODUCTION	1
2.0	RFDA MAINFRAME CHASSIS	3
2.1	DIRECTION OF ARRIVAL (DOA) CHANNELS	3
2.2	POWER COMBINERS	6
2.3	BIT ASSEMBLY	6
2.4	DC VOLTAGE DISTRIBUTION	6
3.0	LAMBDA POWER SUPPLY ASSEMBLY	6
4.0	FAT DATA	9
4.1	DISTRIBUTION GRAPHS	11
4.2	SYSTEM RESPONSE TIME	23
4.3	HARMONICS AND SPURS	23
4.4	OUT-OF-SPEC PRINT OUT	24



*See Appendix sheet
for profile*

11

INTRODUCTION

The Naval Research Laboratory (NRL) Radio Frequency Distribution Assembly (RFDA) is an interface between the Sperry four-channel, fast-switching synthesizer and the EF-111 jamming system antenna ports. The RFDA is a sophisticated, high-speed RF interface designed to convert the banded outputs of the four-channel synthesizer (16 ports) to 36 ports which represent six ordinal directions of arrival (DOA) for the EF-111 jamming system. The RFDA will distribute the RF signals while providing controlled RF amplitudes to simulate the antenna patterns of the EF-111 Electronic Warfare (EW) system. The simulation of the arrival angles which appear between the ordinal directions is performed by controlling the amplitude of the RF signal from the DOA channels. The RFDA is capable of operating over the frequency range of 500MHz to 18GHz, and can rapidly switch between varying frequencies and attenuation levels. *f*

The RFDA unit consists of five DOA channels. Input to four of these channels comes from the banded output of the frequency synthesizer; the fifth channel is for external input. The output of the RFDA unit is taken from six power combiner subassemblies. These six outputs represent the ordinal directions of the system (30°, 90°, 150°, 210°, 270°, 330°) and are a summation of all five DOA channels and a separate noise input.

The RFDA is composed of two major items:

- ° RFDA Mainframe Chassis
- ° LAMBDA Power Supply Assembly

Figure 1 is an overall system block diagram of the RFDA indicating the major subassemblies.

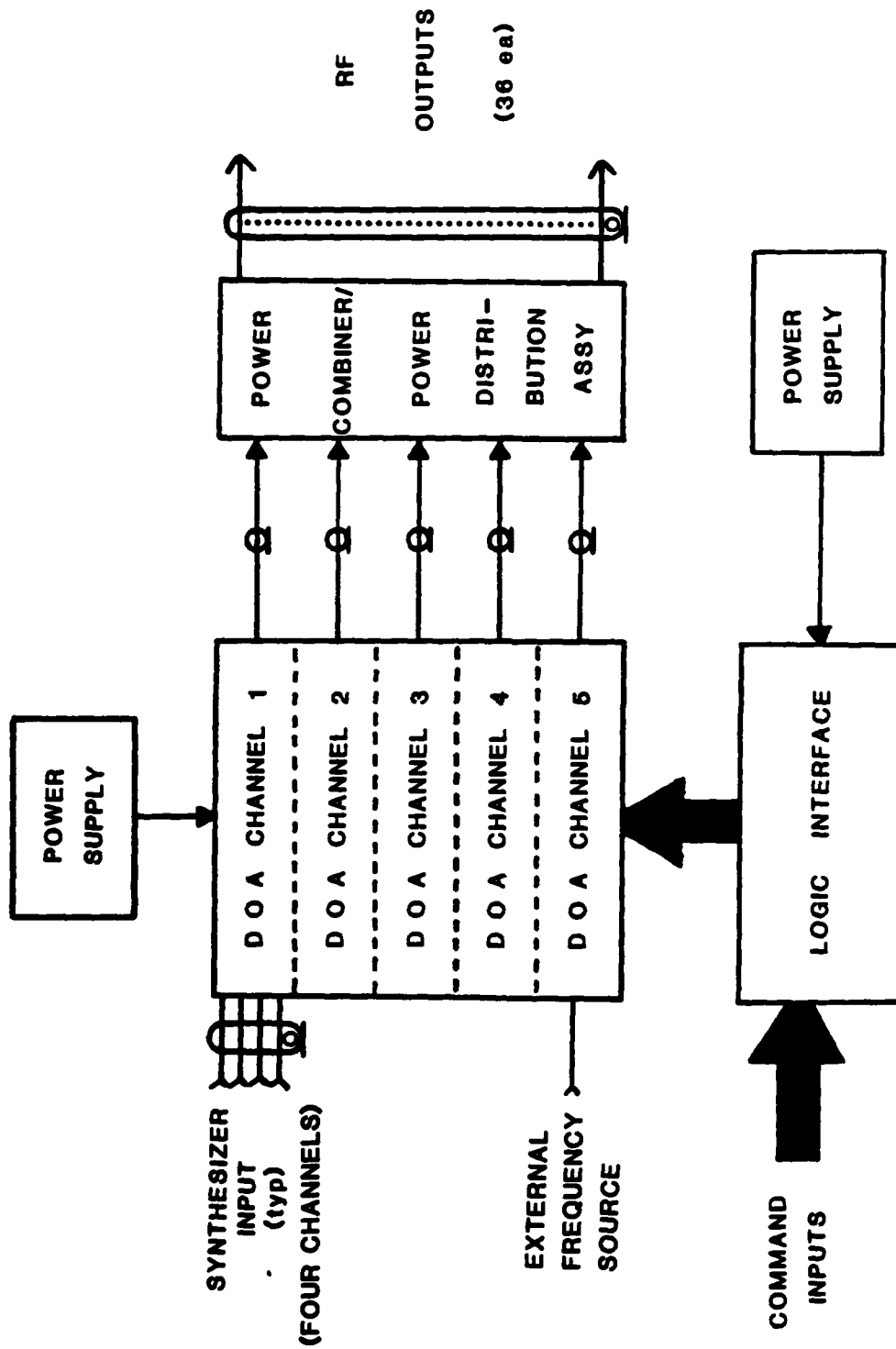

Figure 1 RFDA Block Diagram

2.0 RFDA Mainframe Chassis

The RFDA Mainframe Chassis consists of the following:

- DOA Channels (5)
- Power Combiners (6)
- BIT Assembly
- DC Voltage Distribution

A discussion of each of these areas follows:

2.1 DIRECTION OF ARRIVAL (DOA) CHANNELS

Contained within the MAINFRAME CHASSIS ASSEMBLY are five identical DOA channels. Four of these channels are driven from the NRL frequency synthesizer delivered under contract N00173-80-C-0519. The fifth channel is driven from external frequency sources. The RF input is divided into four bands:

- Band 1 0.5 - 2.047875GHz
- Band 2 2.048 - 8.191875GHz
- Band 3 8.912 - 13.311875GHz
- Band 4 13.312 - 18.000 GHz

Each of these bands (except .5 and 18) is extended by 250MHz by FM modulation.

Three amplifier bands are formed by bands 1 and 2 and the combination of bands 3 and 4.

Following the amplifiers is a switched bandpass filter bank. Each filter is less than an octave wide with at least 40 dB of stopband attenuation. This, coupled with 60 dB of isolation from the switches, allows the maintenance of -40 dBc spurious and harmonic signals.

The output of the filter bank is fed to a pair of three-way power dividers which are followed by six programmable attenuators. Three of the attenuators cover the band from 0.5 to 8.5 GHz and the other three cover 7.5 to 18 GHz. Each attenuator is capable of 40 dB of attenuation above insertion loss with a minimum programmable step size of 1dB. It is the combination of these six attenuators and the following switches which performs the function of simulating the different angles of arrival and antenna patterns.

The outputs of the programmable attenuators are fed to the inputs of the output transfer switches. Each switch has an input from a low band and a high band attenuator. Each switch also has two outputs which are separated by 180°, i.e., the switch that controls 30° also controls 210°.

Six directions, 30°, 90°, 150°, 210°, 270°, and 330°, are output from each channel.

Each DOA channel is independently controllable from the Advanced Tactical Electronic Warfare Equipment Simulator, (ATEWES) Digital Generator Unit (DGU). The interface between the DGU and each channel is four digital logic cards. Three of the cards control the six programmable attenuators, one high-band and one low-band attenuator per card. Inputs to this card are frequency, desired attenuation, and DOA. Outputs to the attenuators are a corrected attenuation command.

The fourth card is the input/output control board. This card controls the filter bank switches, the output transfer switches and system timing. Inputs are frequency and DOA. Outputs are frequency to the attenuator boards, switch control signals, and timing signals.

Figure 2 is a block diagram of a single DOA channel. There are five identical channels within the RFDA Mainframe.

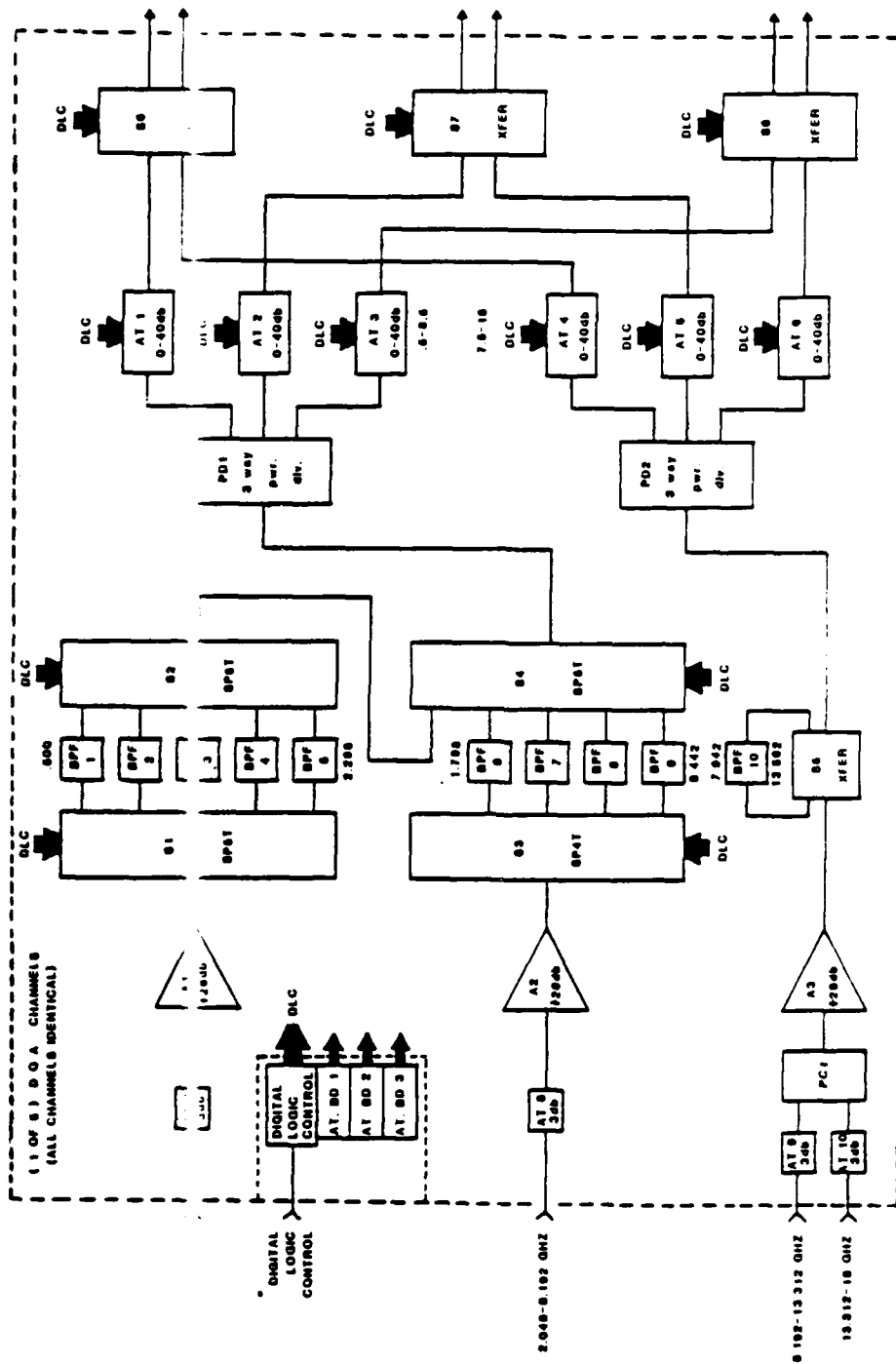

Figure 2 DOA CHANNEL BLOCK DIAGRAM

2.2 POWER COMBINER

The six outputs of each DOA channel are incorporated into six directions of arrival in the power combiners. For example, the 30° outputs of the six DOA channels are combined in a single power combiner. Figure 3 shows the Block Diagram of a power combiner. The four inputs from the synthesizer-fed DOA channels are combined in a single four-way divider. The input from the fifth DOA channel and an external noise input are mixed in a two-way divider. A four-port directional coupler is used to combine the power divider outputs into a single output and also allow a sample port for the BIT Output.

2.3 BIT ASSEMBLY

A Built-In-Test (BIT) output is provided for system monitoring. An RF sample is available from each power combiner as an attenuated specimen of its output signal. The six BIT outputs are brought together at a single-pole, six-throw coaxial switch. This allows the operator to choose which output to monitor. The BIT output is on the front panel of the mainframe chassis.

2.4 DC VOLTAGE DISTRIBUTION

Distribution of DC voltages used within each DOA channel is from eight terminal strips located within the RFDA mainframe chassis. Each DOA channel contains two terminal strips which feed the appropriate DC voltages to the components within that channel.

3.0 LAMBDA POWER SUPPLY ASSEMBLY

The RFDA requires a number of different DC voltages to operate. These voltages are furnished from a separate power supply assembly consisting of four Radio-Electronic-Television Manufacture's Association (RETMA) rack mounted drawers. These four drawers provide

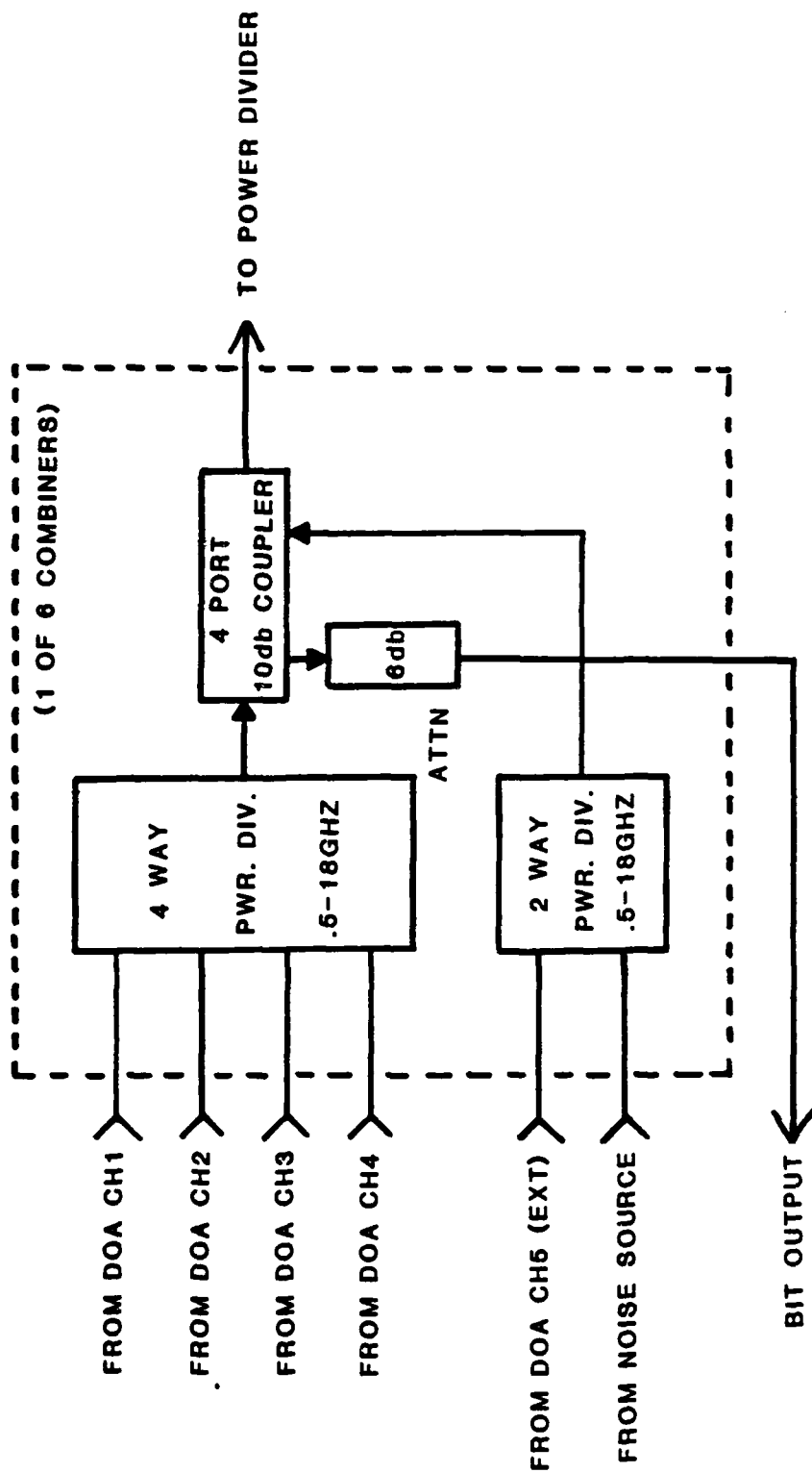

Figure 3 POWER COMBINER DIAGRAM

the necessary voltages to operate the RFDA and digital logic cards. Two of the drawers are used by the RF components (and the BIT switch) and the other two drawers supply the logic boards.

These power supplies are Lambda LN series, commercial quality, meeting many of the MIL specifications for temperature, shock, humidity, and vibration. Remote sensing is used to eliminate the effect of power output lead resistance on DC regulation. External overload protection automatically limits the output current to a preset value, thereby providing protection for the load and power supply. An overvoltage protection module crowbars the output when trip level is exceeded.

The power supply drawers are subdivided as follows:

POWER SUPPLY DRAWER 1
RF DRAWER 1
LAMBDA NUMBER 16714-2
+18V (5 ea)

POWER SUPPLY DRAWER 2
LOGIC DRAWER 2
LAMBDA NUMBER 16715-2
±15V (1 ea)
-5.2V (1 ea)
-2V (5 ea)
+5V (1 ea)

POWER SUPPLY DRAWER 4
RF DRAWER 2
LAMBDA NUMBER 16726-3
±15V (1 ea)
± 5V (1 ea)
+28V (1 ea)

POWER SUPPLY DRAWER 3
LOGIC DRAWER 1
LAMBDA NUMBER 16727-2
±5V (4 ea)

4.0 FAT DATA

The data contained in this section is the Factory Acceptance Test data taken on DOA channels 1,2,3, and 4 in November 1983.

The Factory Acceptance Test (FAT) requirements for the DOA channels were to measure the power output at 55 specific frequencies within the 500MHz to 18GHz range, then attenuate these signals by 0dB to -31dB, and compare the output power to the required output power. These measured outputs were specified to be within ± 2 dB of the required output power. Over the 10,560 measurements per channel (55 frequencies x 32dB attenuation range x 6 output ports) the specification was met over 99.6% of the cases.

4.1 DISTRIBUTION GRAPHS

The following table is a breakdown of what the distribution graphs show us:

CHANNEL 1

OUTPUT	± 1 dB(%)	± 2 dB(%)	MAX ERROR (dB)	FIGURE NUMBER
30°	98	100	1.52	4.1
90°	98	100	1.54	4.2
150°	98	100	1.37	4.3
210°	95	100	1.66	4.4
270°	95	99.83	2.02	4.5
330°	94	99.94	2.06	4.6

CHANNEL 2

OUTPUT	± 1 dB(%)	± 2 dB(%)	MAX ERROR (dB)	FIGURE NUMBER
30°	96	100	1.85	4.7
90°	93	99.94	2.02	4.8
150°	88	99.94	2.10	4.9
210°	92	99.37	2.33	4.10
270°	94	100	1.81	4.11
330°	88	99.86	2.55	4.12

CHANNEL 3

OUTPUT	±1dB(%)	±2dB(%)	MAX ERROR (dB)	FIGURE NUMBER
30°	92	99.77	3.00	4.13
90°	98	100	1.99	4.14
150°	95	99.94	2.22	4.15
210°	94	99.72	2.95	4.16
270°	95	99.94	2.06	4.17
330°	90	99.83	2.23	4.18

CHANNEL 4

OUTPUT	±1dB(%)	±2dB(%)	MAX ERROR (dB)	FIGURE NUMBER
30°	88	99.03	2.31	4.19
90°	94	99.72	2.56	4.20
150°	89	97.61	2.57	4.21
210°	82	96.42	2.44	4.22
270°	90	99.43	2.39	4.23
330°	98	100	1.54	4.24

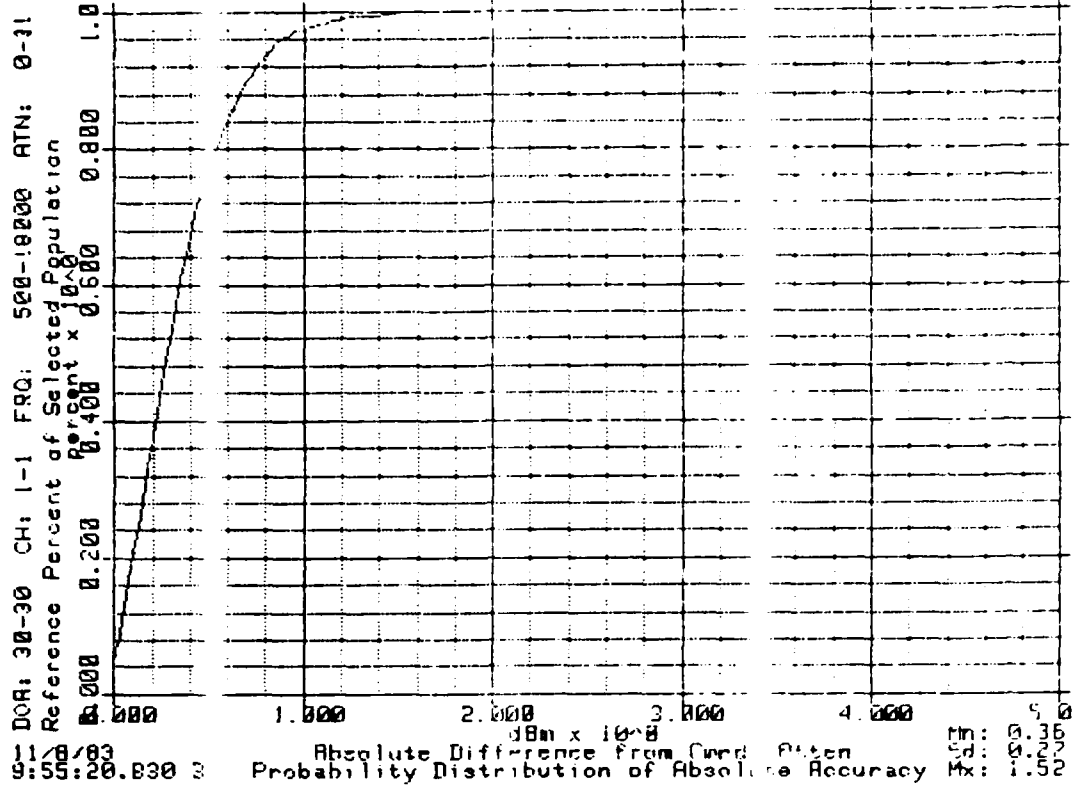

FIG. 4.1

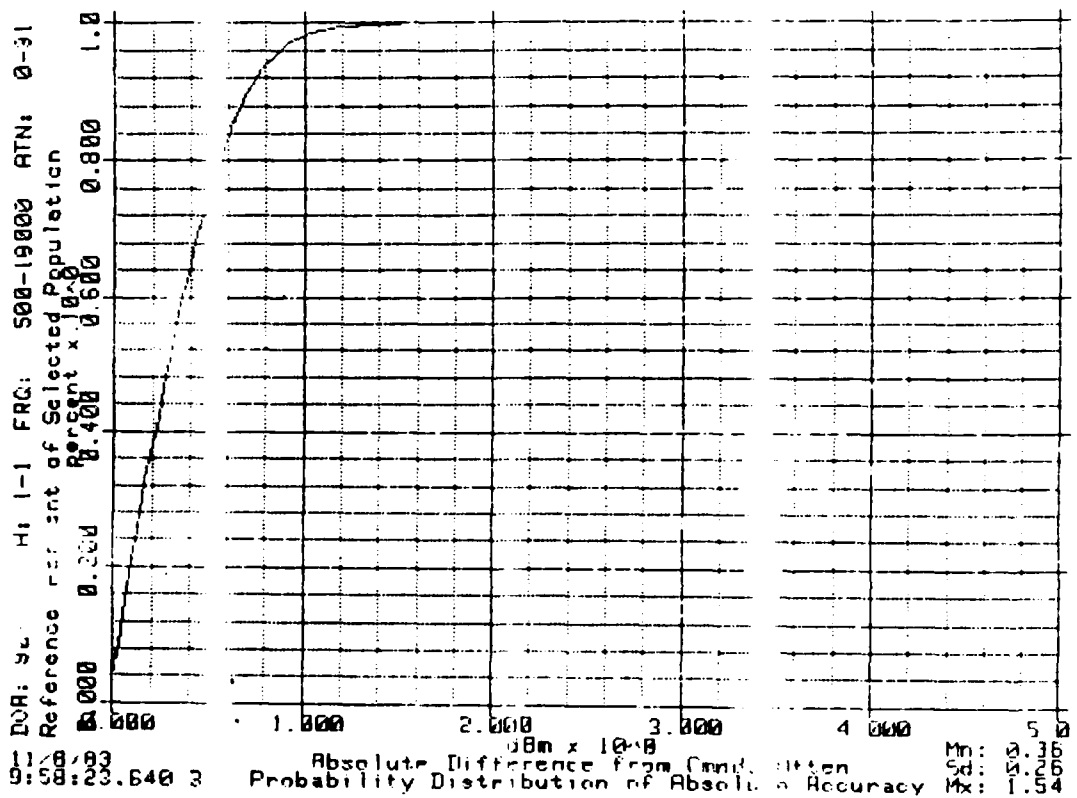

FIG. 4.2

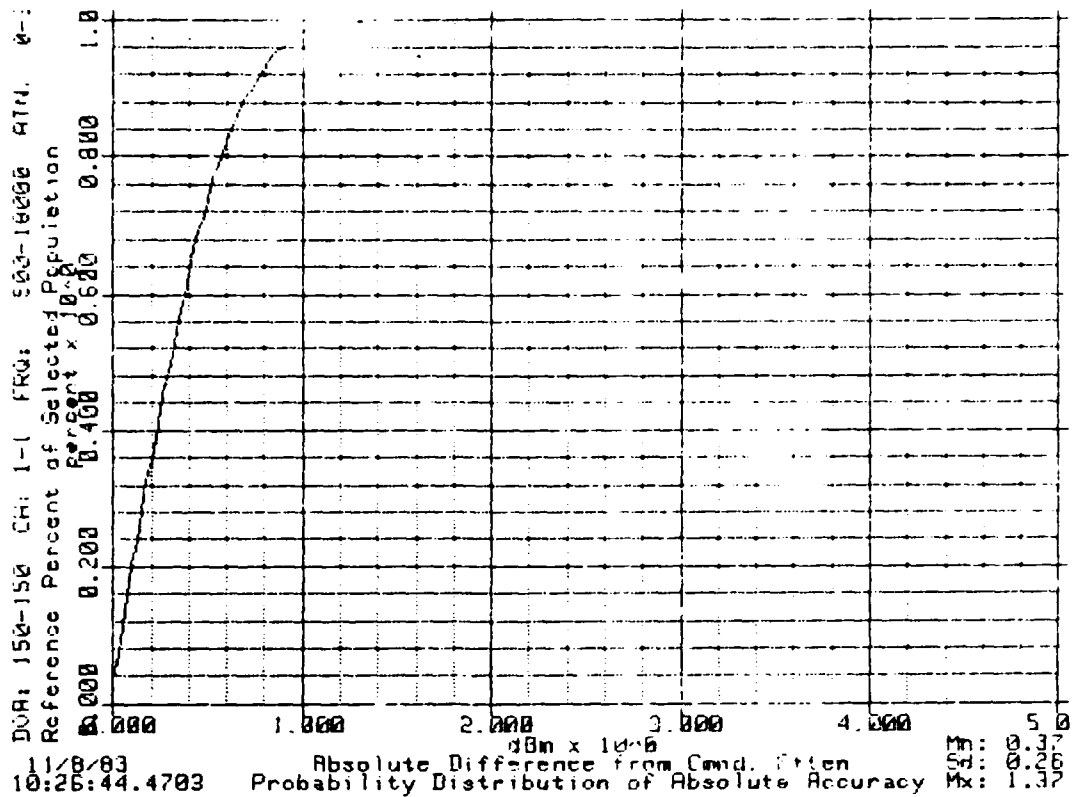

FIG. 4.3

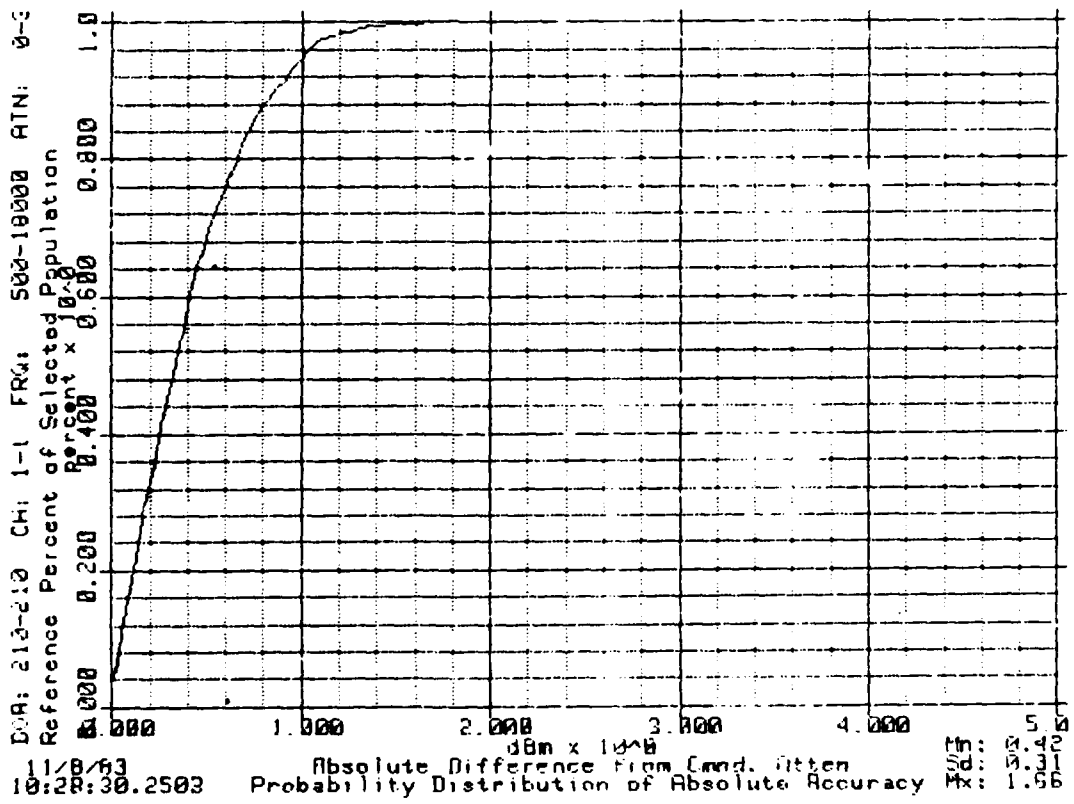

FIG. 4.4

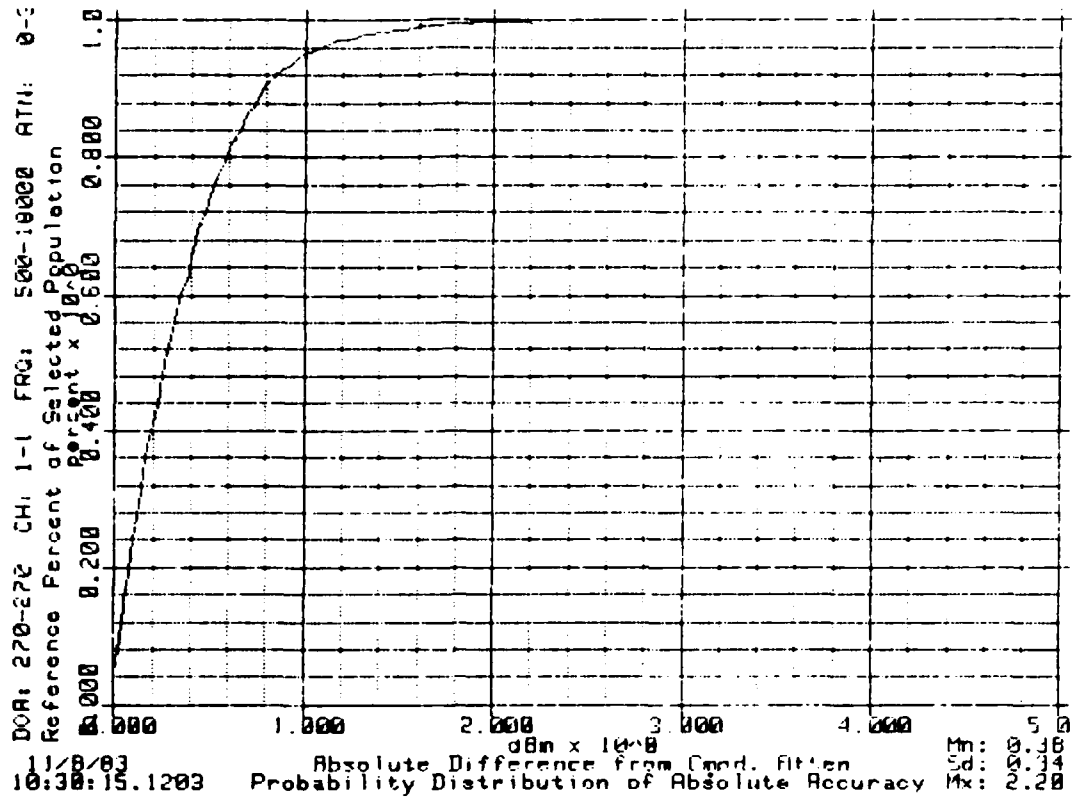

FIG. 4.5

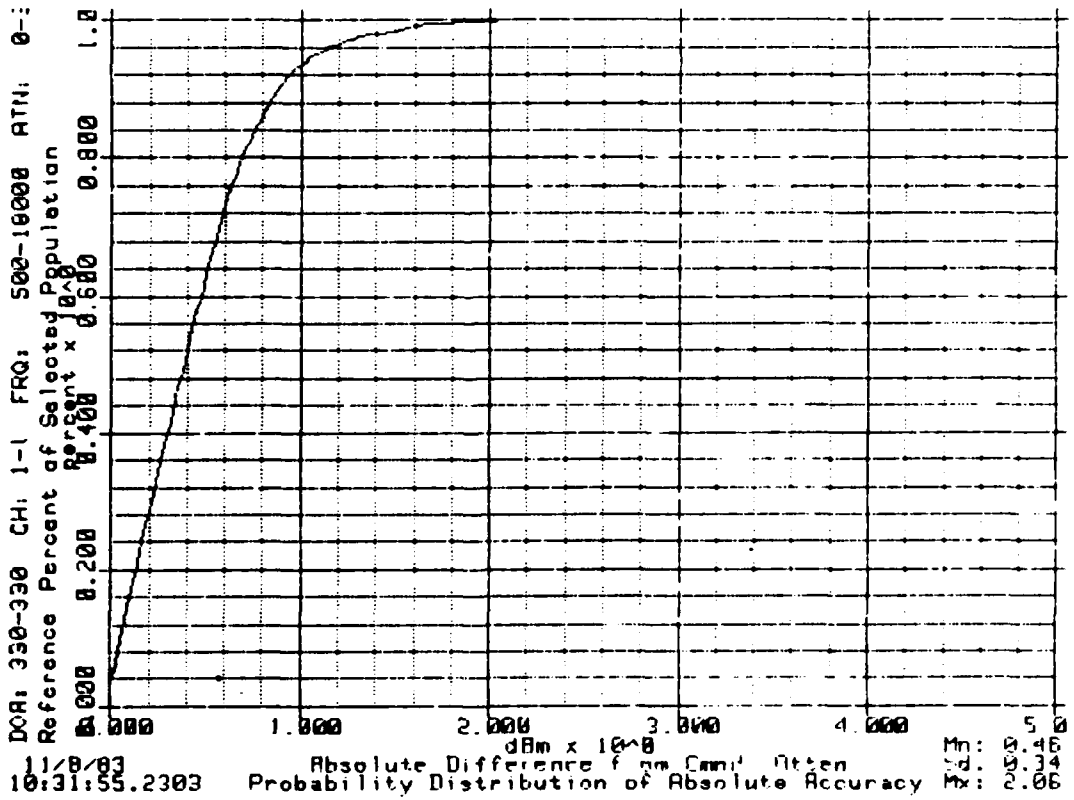

FIG. 4.6

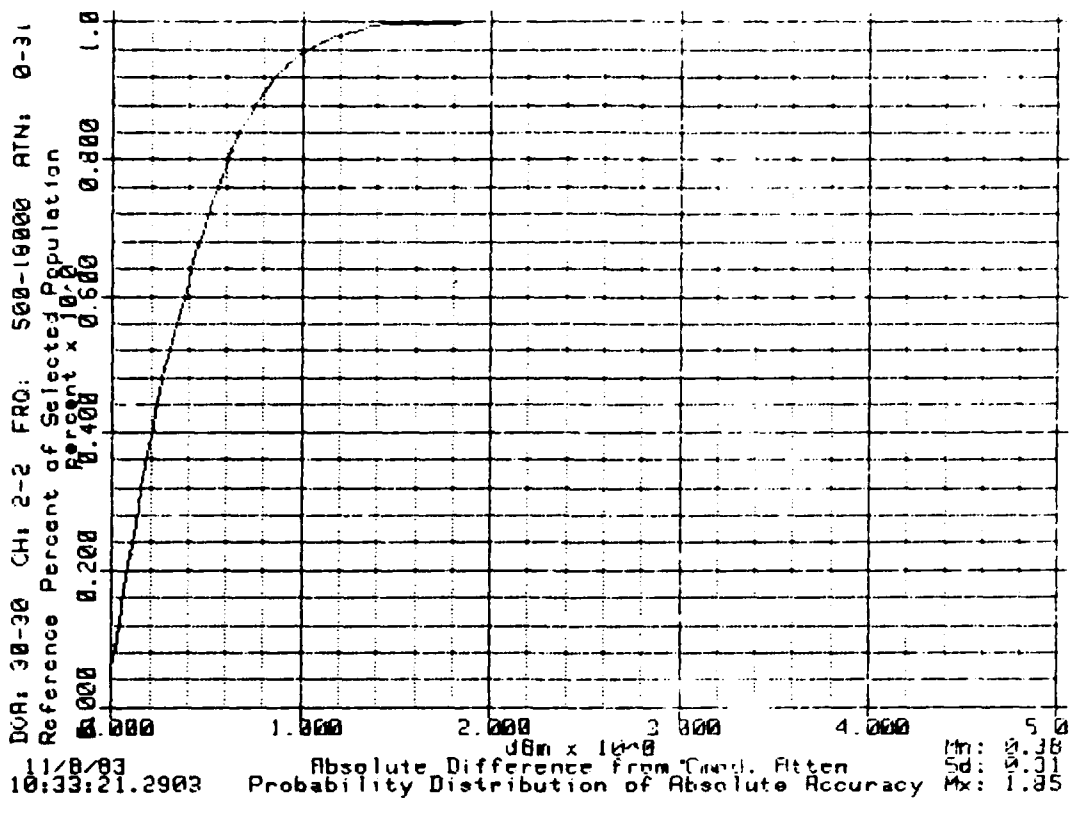

FIG. 4.7

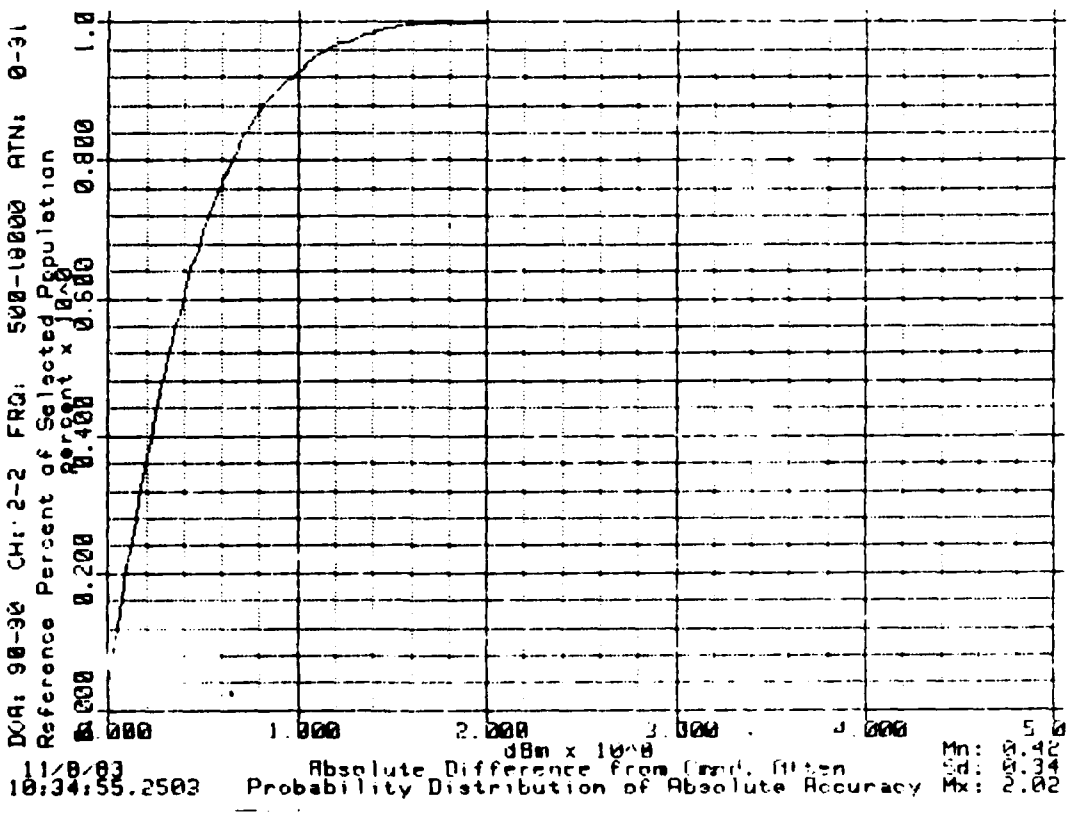

FIG. 4.8

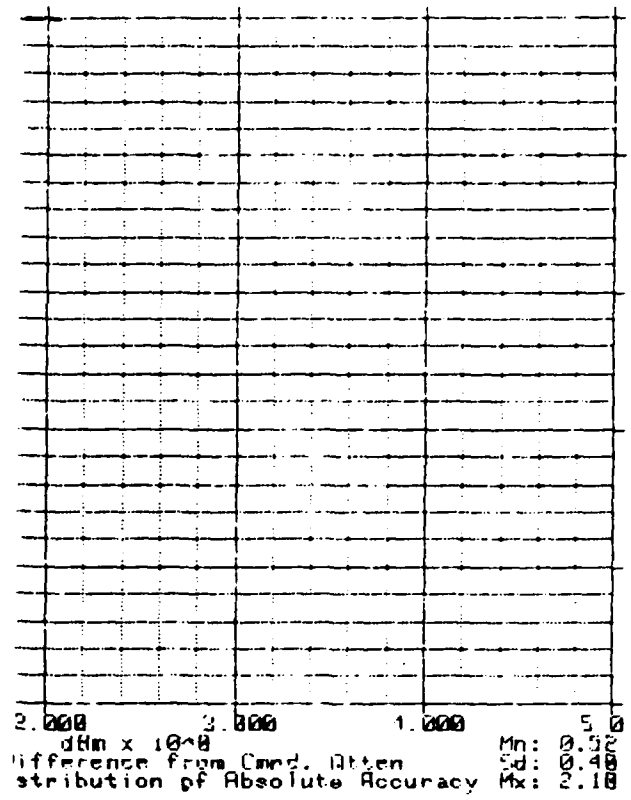
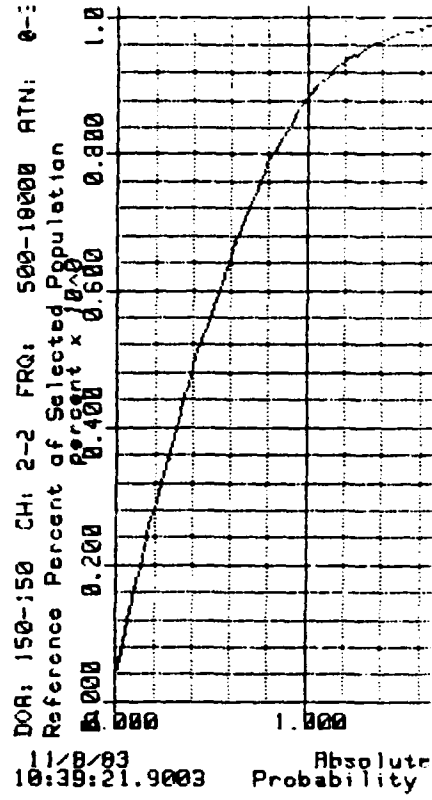

FIG. 4.9

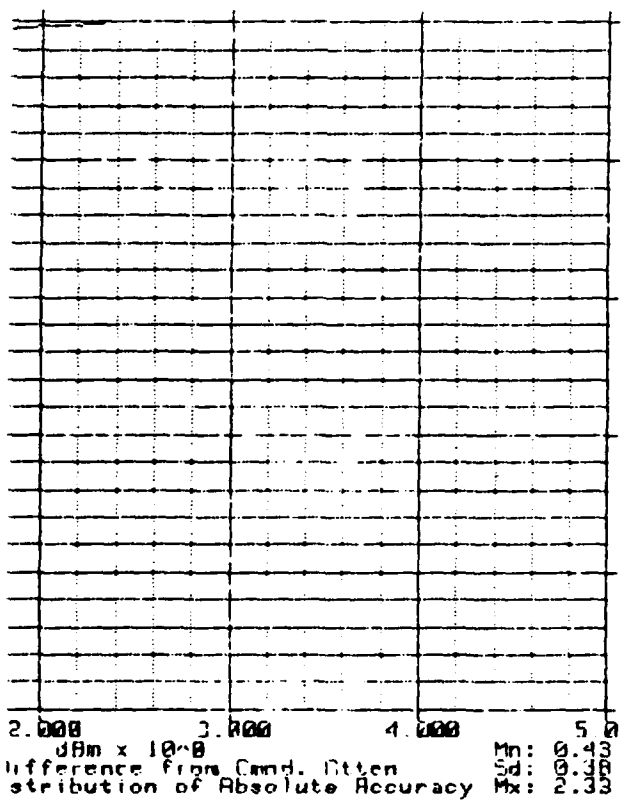
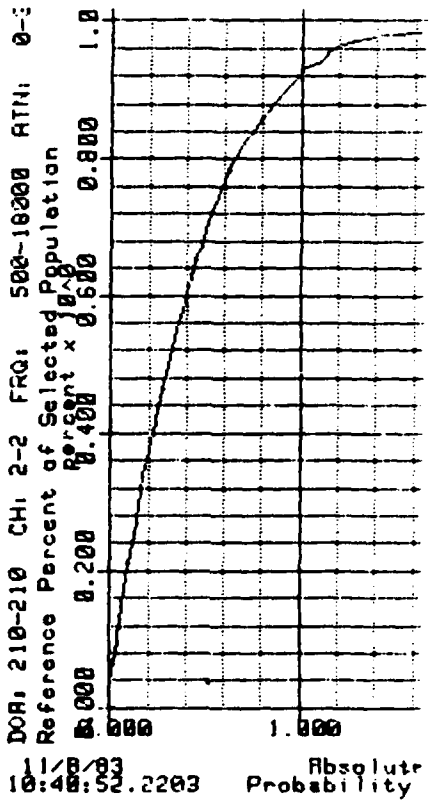

FIG. 4.10

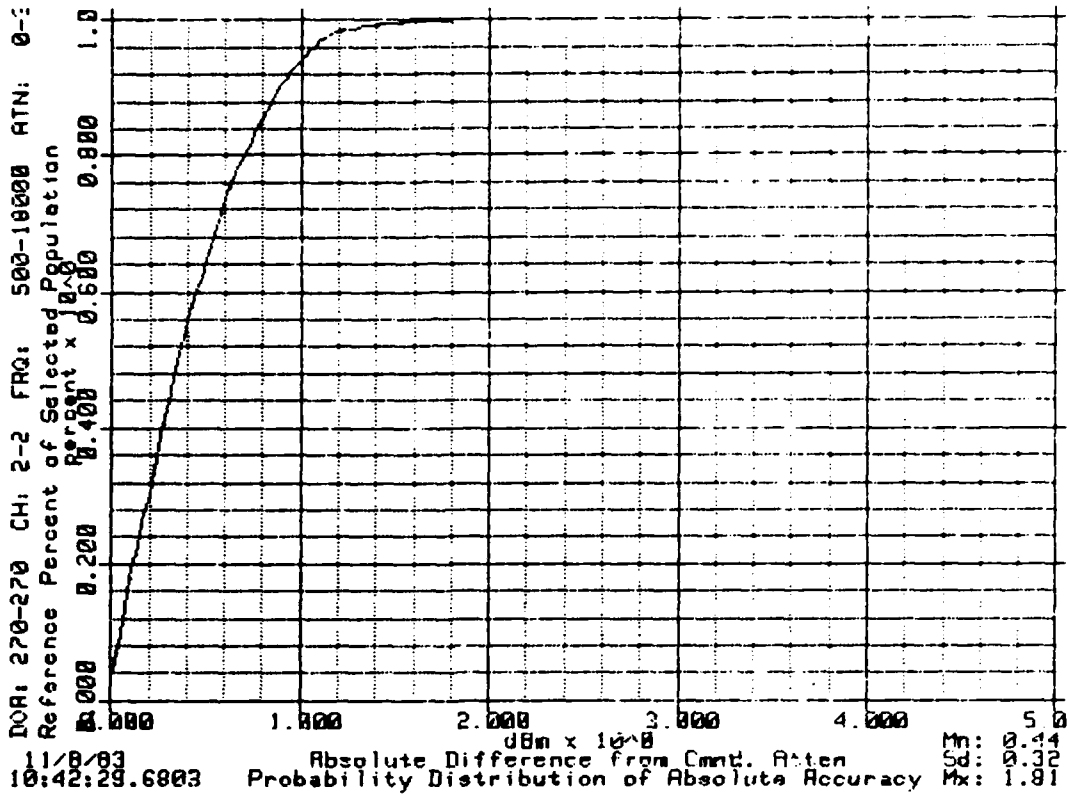

FIG. 4.11

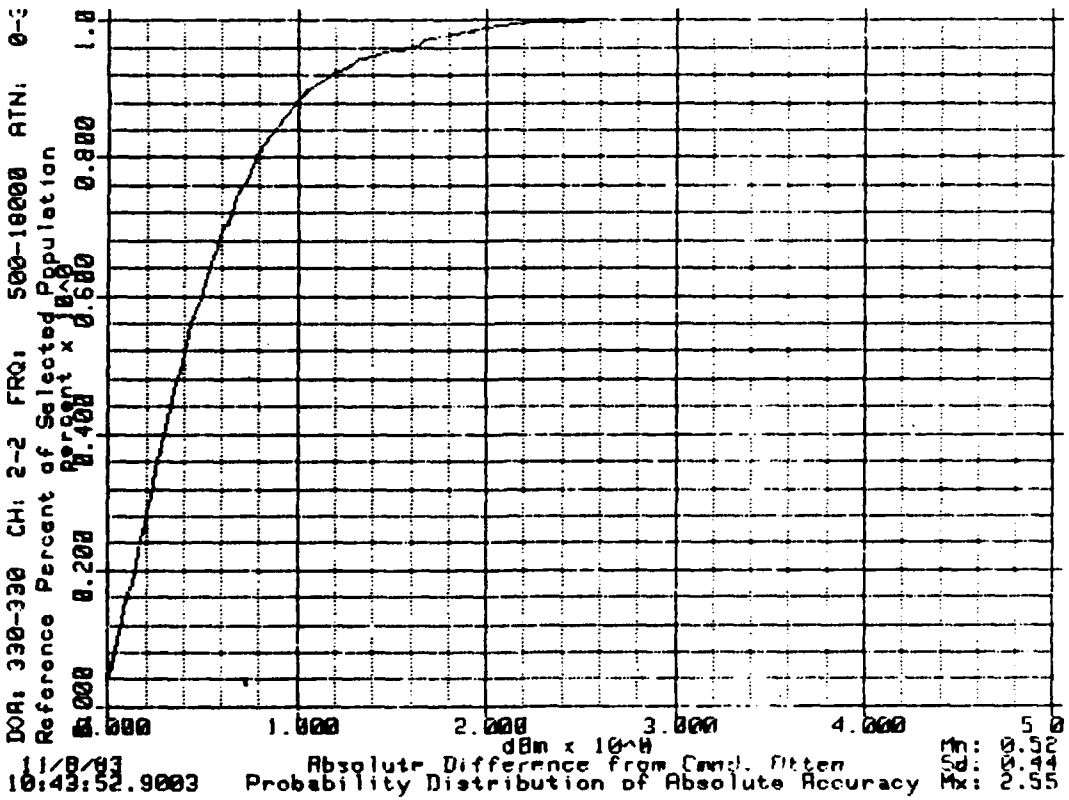

FIG. 4.12

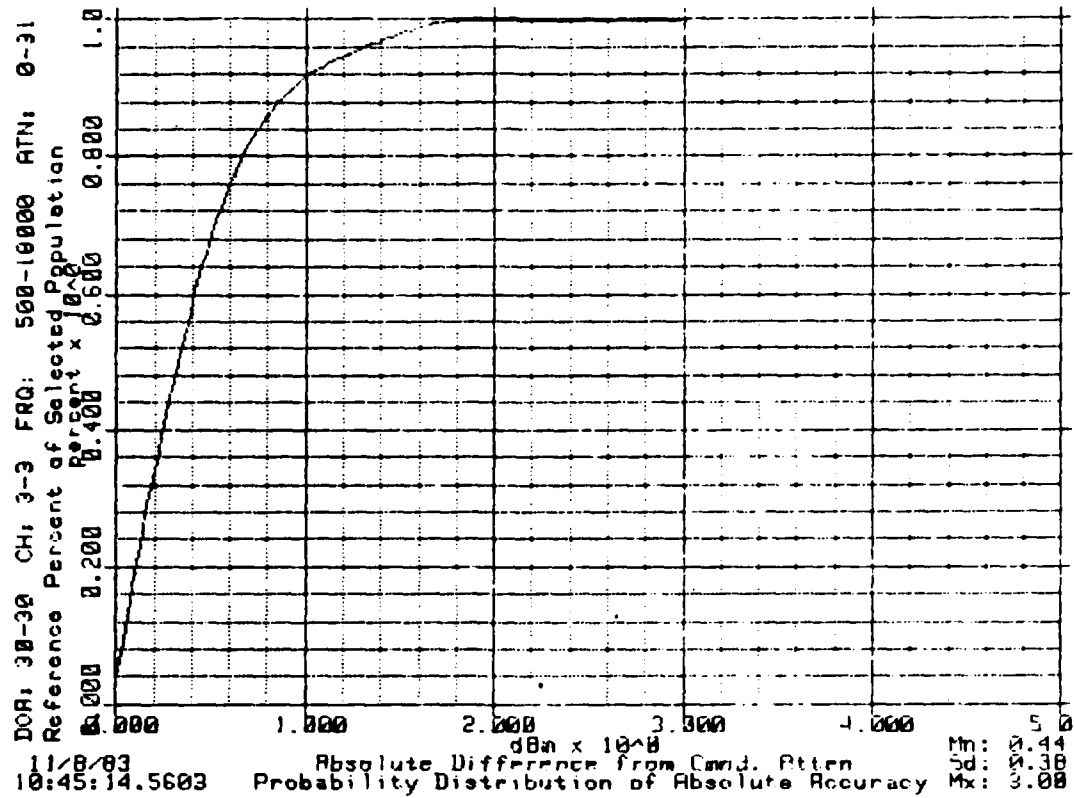

FIG. 4.13

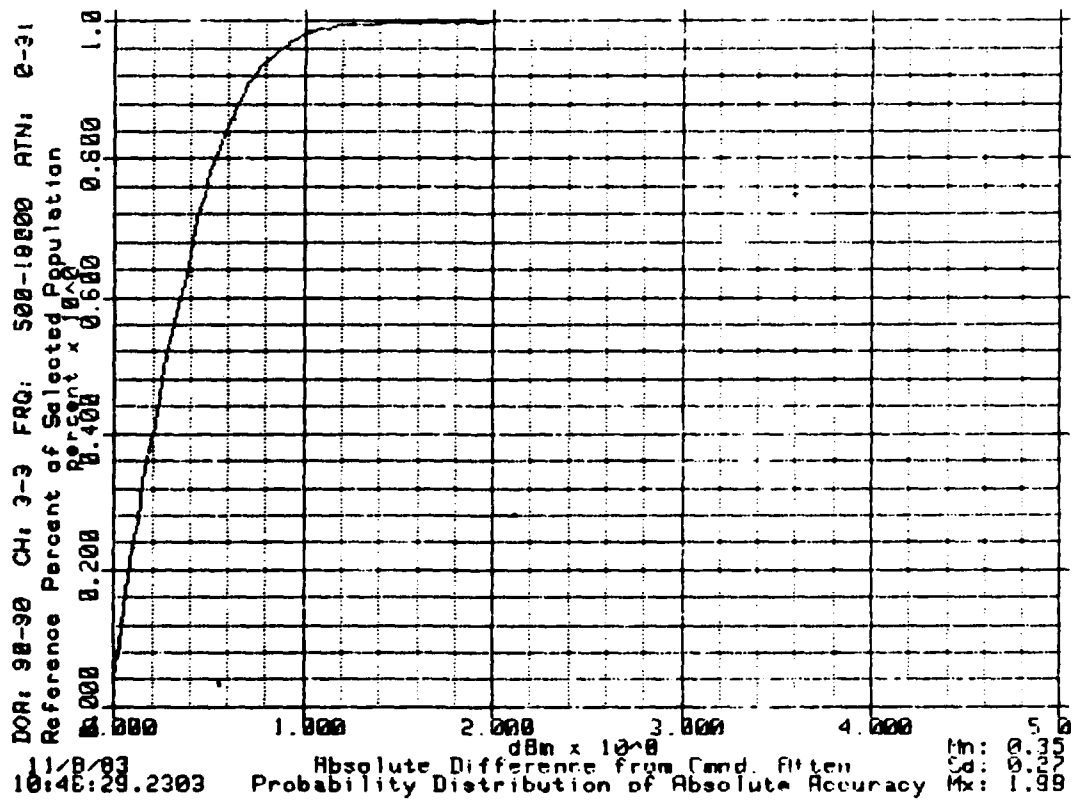

FIG. 4.14

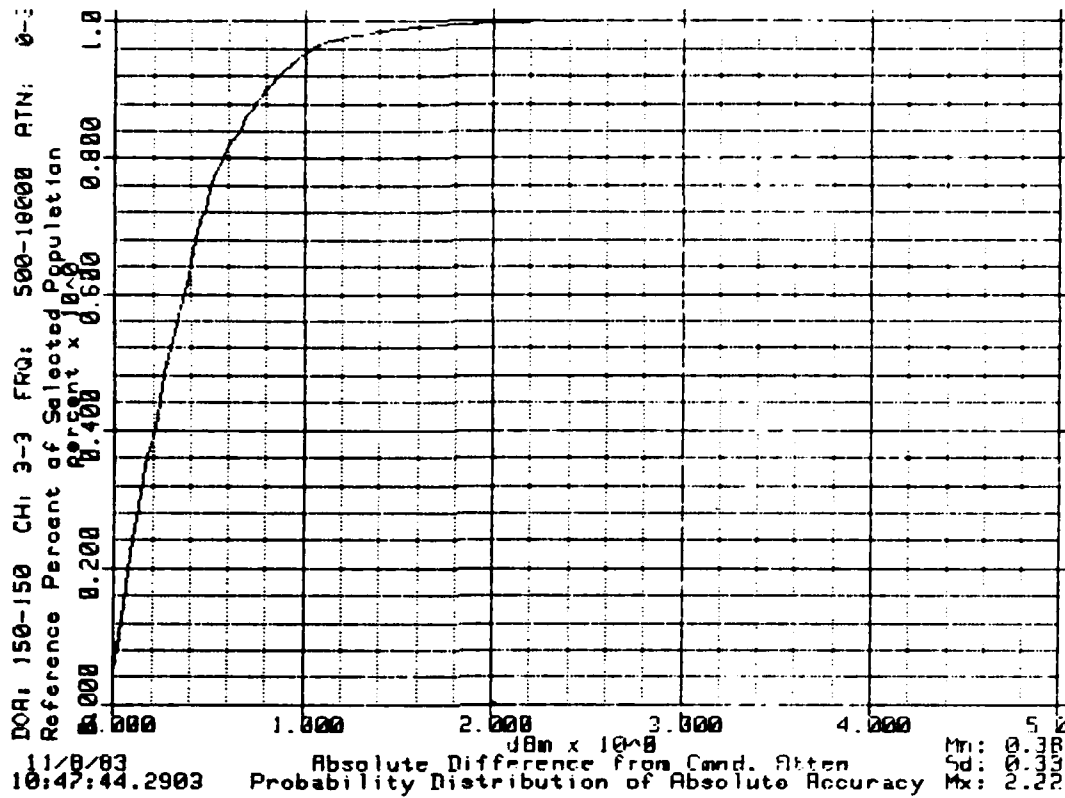

FIG. 4.15

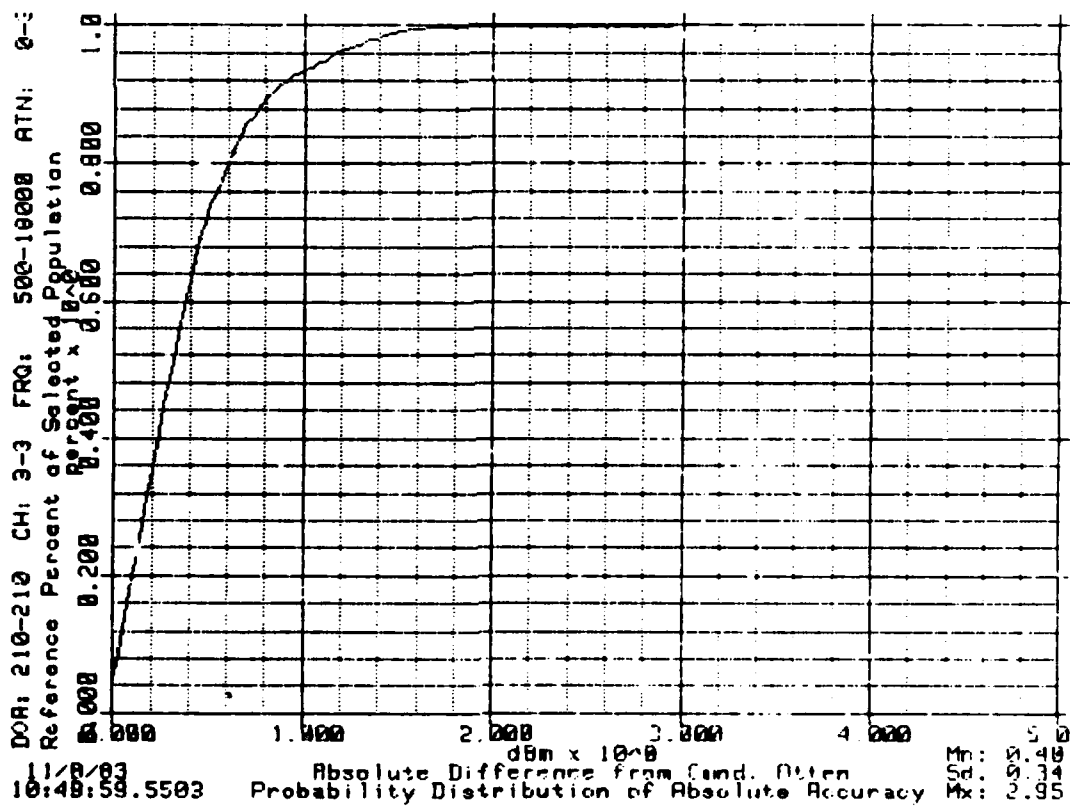

FIG. 4.16

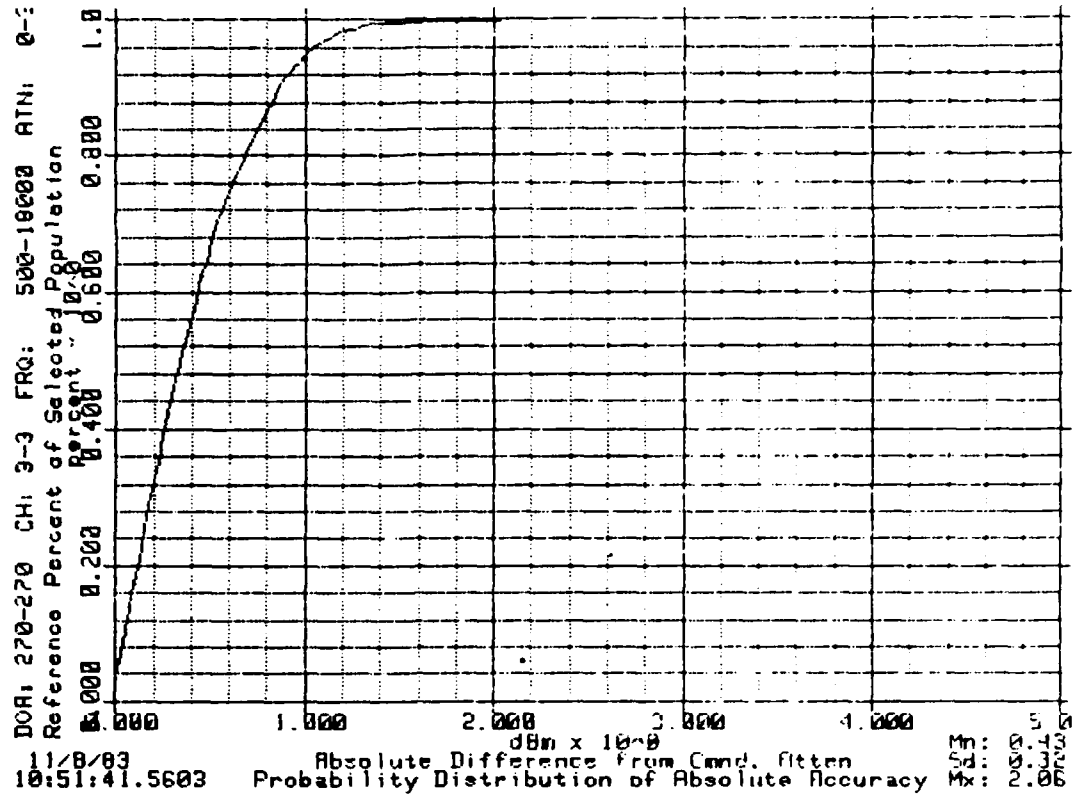

FIG. 4.17

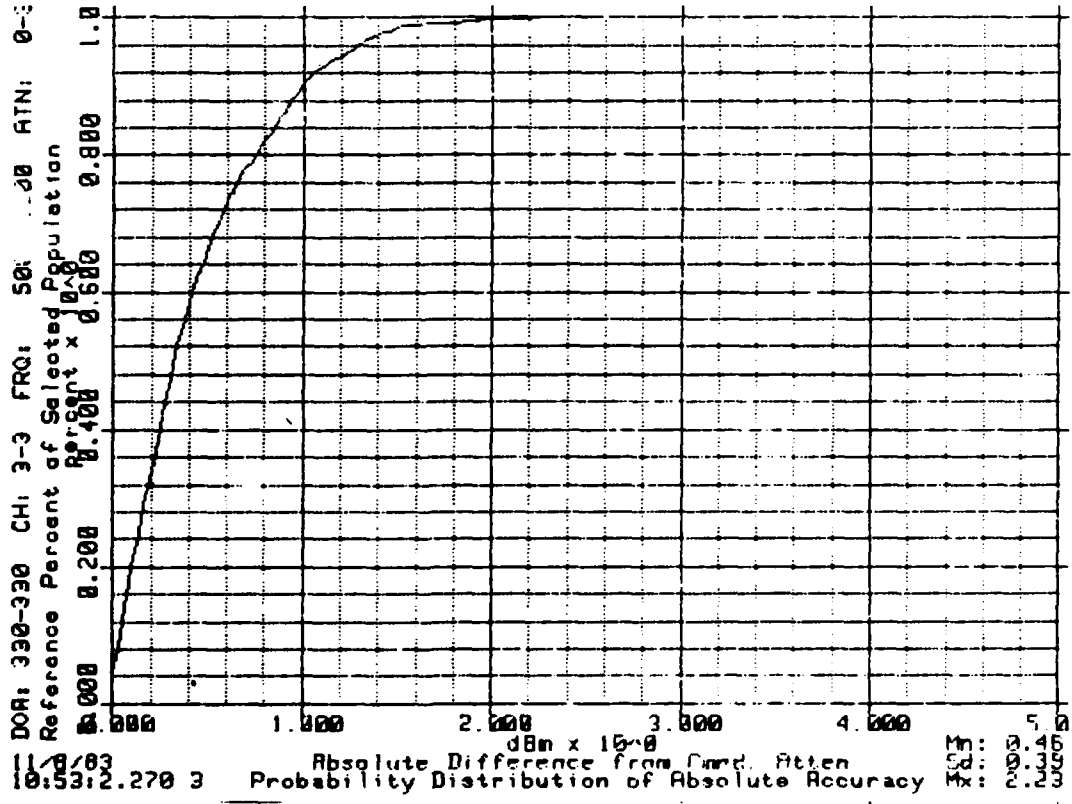

FIG. 4.18

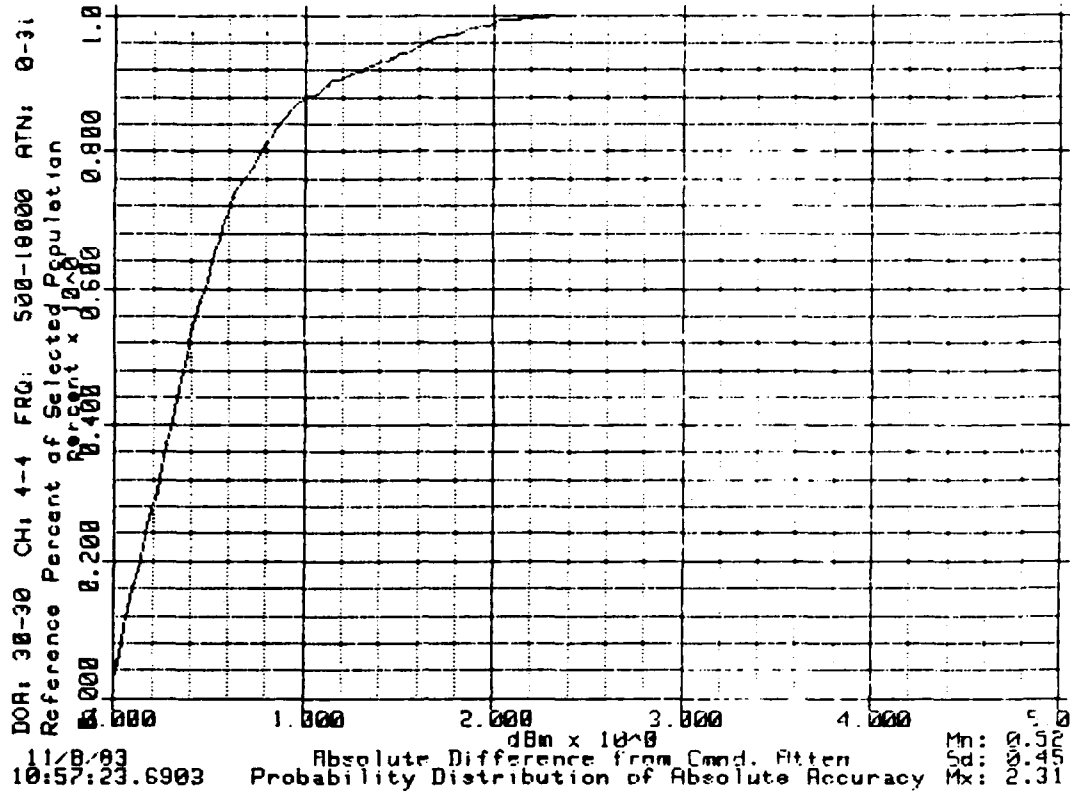

FIG. 4.19

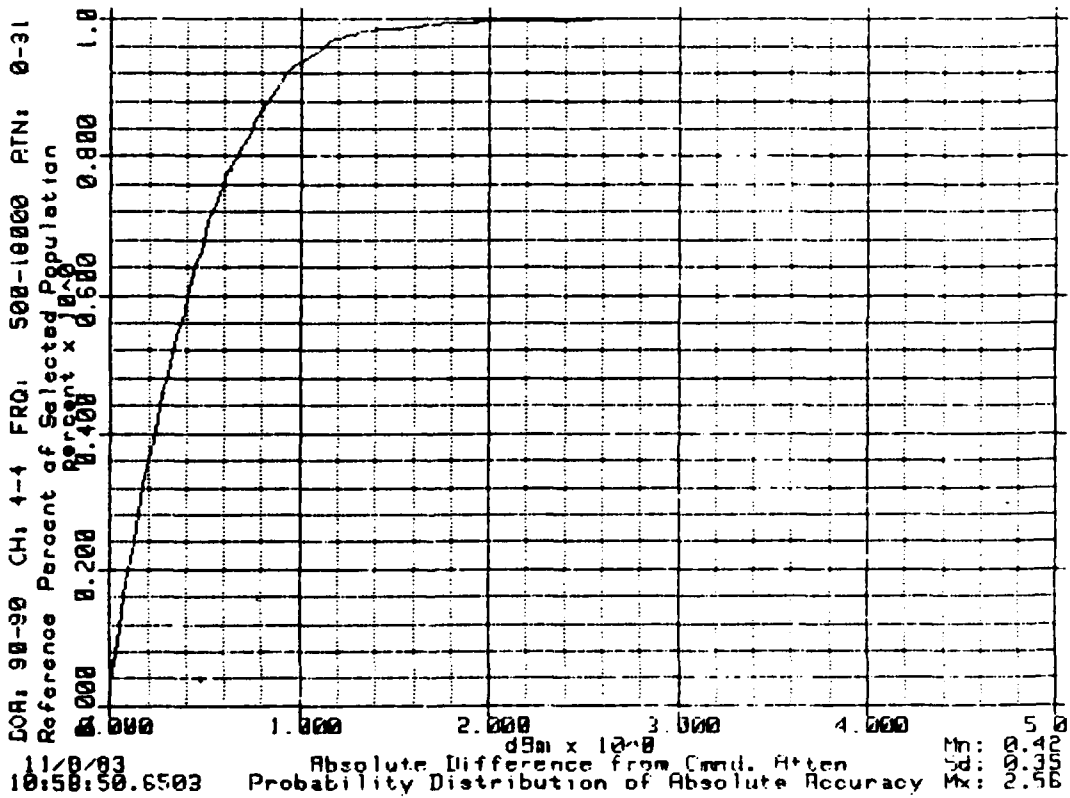

FIG. 4.20

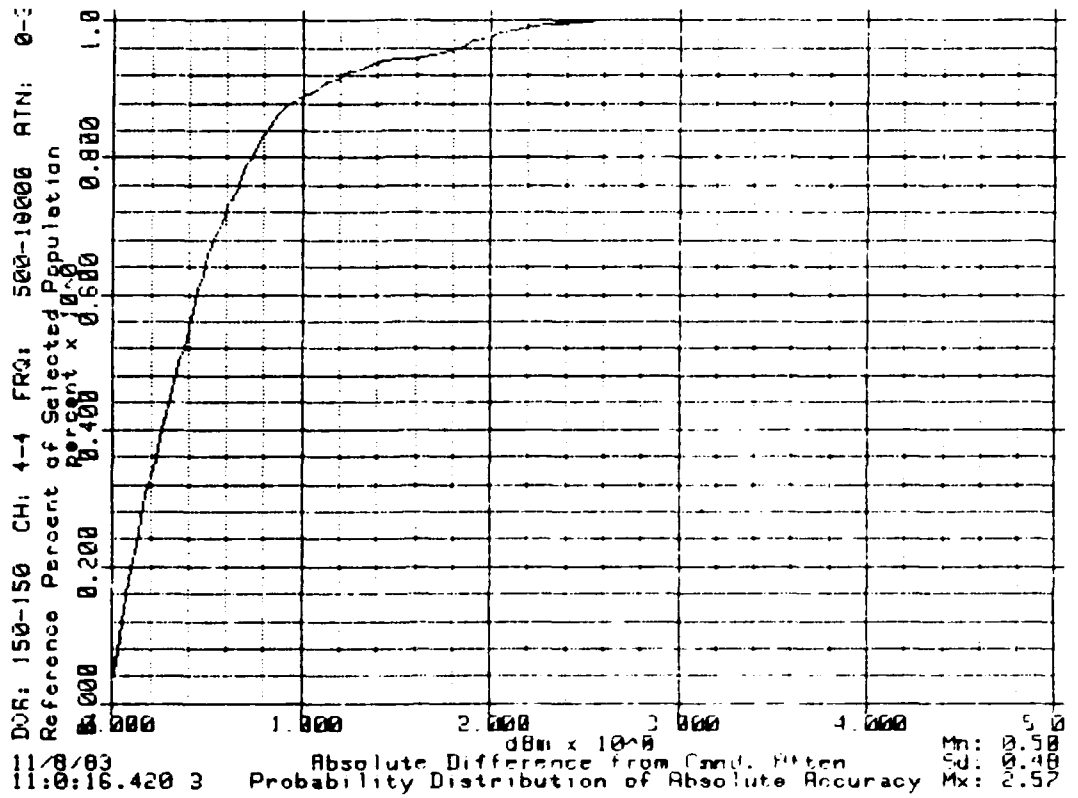

FIG. 4.21

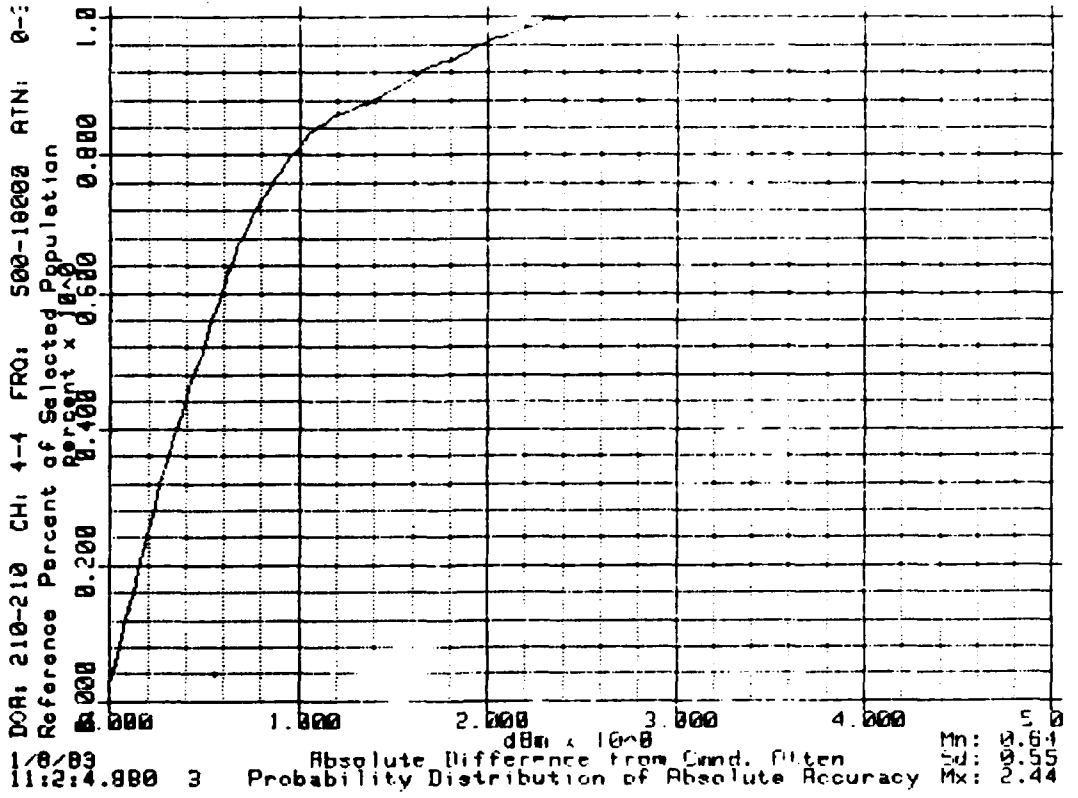

FIG. 4.22

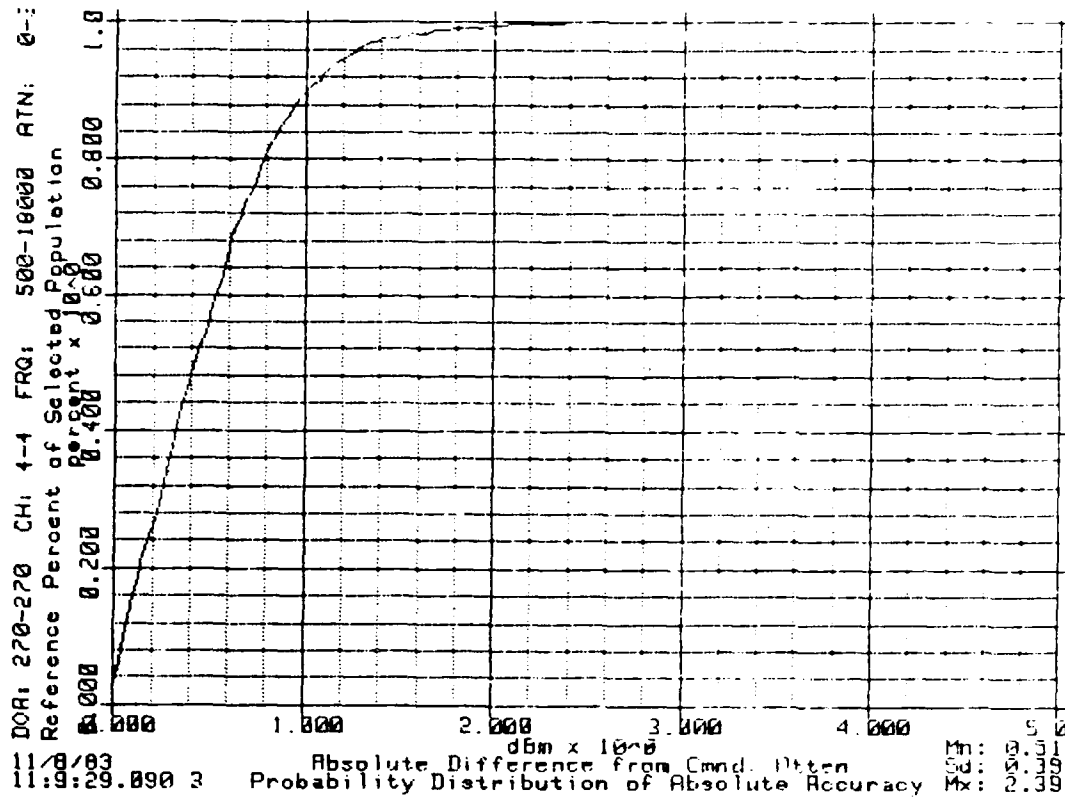

FIG. 4.23

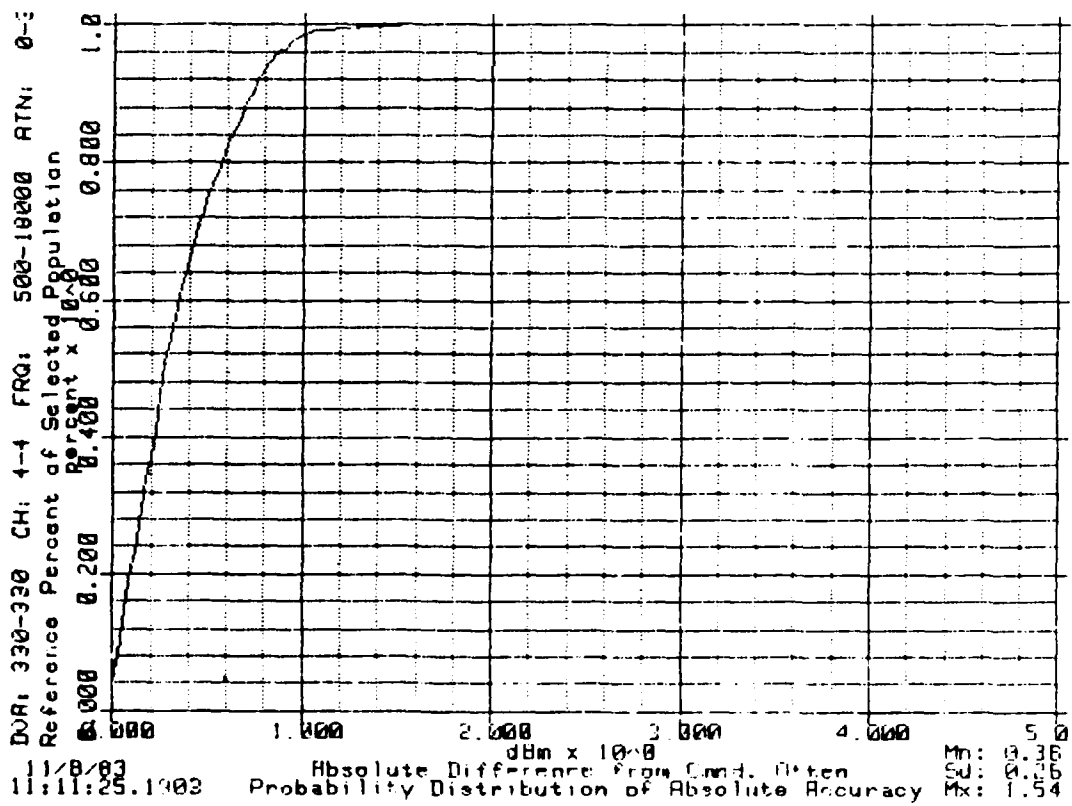

FIG. 4.24

4.2 SYSTEM RESPONSE TIME

By following the procedure specified in RFDA FACTORY ACCEPTANCE TEST, Section 3.2.1.4, the switching speed of all switches can be tested. The specification for maximum system response time is 250 nsec.

The maximum response time of each channel is indicated below:

CHANNEL	MAXIMUM RESPONSE TIME
1	170 nsec
2	160 nsec
3	180 nsec
4	200 nsec

4.3 HARMONICS AND SPURS

The generation of harmonics and spurs is controlled to a level no greater than 40dB below the fundamental signal level over the entire frequency range of each channel.

This is accomplished by the ten (10) band pass filters and transfer switch 5. The results are listed below:

CHANNEL	HIGHEST HARMONIC/SPUR LEVEL
1	-42
2	-49
3	-47
4	-47

4.4 OUT-OF-SPEC PRINTOUT

The following table is an explanation of the out-of-spec printout.

CHANNEL 1

OUTPUT	NUMBER OF ERRORS	MAX ERROR(dB)	% OUT OF SPEC.
30°	0	NONE	0
90°	0	NONE	0
150°	0	NONE	0
210°	0	NONE	0
270°	3	0.20	.17
330°	1	0.06	.06

CHANNEL 2

30°	0	NONE	0
90°	1	0.02	.06
150°	1	0.10	.06
210°	11	0.33	.63
270°	0	NONE	0
330°	20	0.55	1.14

CHANNEL 3

30°	4	1.00	.23
90°	0	NONE	0
150°	1	0.22	.06
210°	5	0.95	.28
270°	1	0.06	.06
330°	3	0.23	.17

CHANNEL 4

30°	17	0.31	.97
90°	5	0.56	.28
150°	42	0.57	2.39
210°	63	0.44	3.58
270°	10	0.39	.57
330°	0	NONE	0

NOTE: Every one of the 24 outputs reported above is at least 99% within spec except for channel 4 output 150° and 210° which are 87.6% and 96.4% respectively.

By analyzing the out-of-spec printout further, we can see in the 150° output there are 42 errors, the maximum of which is 2.57dB (only 0.57dB out-of-spec).

Of these 42 errors 26 are at 9984 MHz, the remaining 16 are at 3712 and 3717 MHz. This indicates that the attenuators used for this output has .5dB holes in them at these frequencies.

Of the 63 errors in the 210° output the maximum error is 2.44dB (only 0.44dB out of spec). Twenty-five (25) errors are at 767 and 768MHz, and 22 errors are at 10496 MHz. Indicating, once again, 5dB holes in the attenuators used for this output at these frequencies.

FAT	Out-of-Spec	Locations	(reference)	14	24	17	660	11/8/83
Ch: 1	DOA: 270	Freq: 15616	Atn 3	Pwr: -9.20	Diff: -2.20			
Ch: 1	DOA: 270	Freq: 15616	Atn 28	Pwr: -34.20	Diff: -2.20			
Ch: 1	DOA: 270	Freq: 15616	Atn 29	Pwr: -25.01	Diff: -2.01			
Ch: 1	DOA: 330	Freq: 2048	Atn 6	Pwr: -5.56	Diff: -2.06			
Ch: 2	DOA: 90	Freq: 17664	Atn 29	Pwr: -27.52	Diff: -2.02			
Ch: 2	DOA: 150	Freq: 8192	Atn 12	Pwr: -11.40	Diff: 2.10			
Ch: 2	DOA: 210	Freq: 18000	Atn 10	Pwr: -18.76	Diff: -2.26			
Ch: 2	DOA: 10	Freq: 18000	Atn 11	Pwr: -19.75	Diff: -2.25			
Ch: 2	DOA: 210	Freq: 18000	Atn 13	Pwr: -21.57	Diff: -2.07			
Ch: 2	DOA: 210	Freq: 18000	Atn 14	Pwr: -22.76	Diff: -2.26			
Ch: 2	DOA: 210	Freq: 18000	Atn 15	Pwr: -23.83	Diff: -2.33			
Ch: 2	DOA: 210	Freq: 18000	Atn 20	Pwr: -28.74	Diff: -2.24			
Ch: 2	DOA: 210	Freq: 18000	Atn 24	Pwr: -22.58	Diff: -2.08			
Ch: 2	DOA: 210	Freq: 18000	Atn 25	Pwr: -33.55	Diff: -2.05			
Ch: 2	DOA: 210	Freq: 18000	Atn 28	Pwr: -26.75	Diff: -2.25			
Ch: 2	DOA: 210	Freq: 18000	Atn 29	Pwr: -37.73	Diff: -2.23			
Ch: 2	DOA: 210	Freq: 18000	Atn 30	Pwr: -28.61	Diff: -2.11			
Ch: 2	DOA: 330	Freq: 8192	Atn 5	Pwr: -4.44	Diff: 2.06			
Ch: 2	DOA: 330	Freq: 8192	Atn 6	Pwr: -5.30	Diff: 2.20			
Ch: 2	DOA: 330	Freq: 8192	Atn 7	Pwr: -6.35	Diff: 2.15			
Ch: 2	DOA: 330	Freq: 8192	Atn 8	Pwr: -7.28	Diff: 2.22			
Ch: 2	DOA: 330	Freq: 8192	Atn 9	Pwr: -8.35	Diff: 2.15			
Ch: 2	DOA: 330	Freq: 8192	Atn 12	Pwr: -10.95	Diff: 2.55			
Ch: 2	DOA: 330	Freq: 8192	Atn 14	Pwr: -13.45	Diff: 2.05			
Ch: 2	DOA: 330	Freq: 8192	Atn 15	Pwr: -14.27	Diff: 2.23			
Ch: 2	DOA: 330	Freq: 8192	Atn 23	Pwr: -22.33	Diff: 2.17			
Ch: 2	DOA: 330	Freq: 8192	Atn 24	Pwr: -23.43	Diff: 2.07			
Ch: 2	DOA: 330	Freq: 8192	Atn 25	Pwr: -24.41	Diff: 2.09			
Ch: 2	DOA: 330	Freq: 8192	Atn 26	Pwr: -25.31	Diff: 2.19			
Ch: 2	DOA: 330	Freq: 8192	Atn 27	Pwr: -26.48	Diff: 2.02			
Ch: 2	DOA: 330	Freq: 8192	Atn 30	Pwr: -29.45	Diff: 2.05			
Ch: 2	DOA: 330	Freq: 17664	Atn 11	Pwr: -19.51	Diff: -2.01			
Ch: 2	DOA: 330	Freq: 17664	Atn 28	Pwr: -26.67	Diff: -2.17			
Ch: 2	DOA: 330	Freq: 17664	Atn 29	Pwr: -37.70	Diff: -2.20			
Ch: 2	DOA: 330	Freq: 18000	Atn 15	Pwr: -23.57	Diff: -2.07			
Ch: 2	DOA: 330	Freq: 18000	Atn 28	Pwr: -36.94	Diff: -2.44			
Ch: 2	DOA: 330	Freq: 18000	Atn 29	Pwr: -27.82	Diff: -2.32			
Ch: 3	DOA: 30	Freq: 8191	Atn 0	Pwr: -3.00	Diff: -3.00			
Ch: 3	DOA: 30	Freq: 8191	Atn 1	Pwr: -3.72	Diff: -2.72			
Ch: 3	DOA: 30	Freq: 8191	Atn 2	Pwr: -4.50	Diff: -2.50			
Ch: 3	DOA: 30	Freq: 8191	Atn 3	Pwr: -5.46	Diff: -2.46			
Ch: 3	DOA: 150	Freq: 8960	Atn 12	Pwr: -11.28	Diff: 2.22			
Ch: 3	DOA: 210	Freq: 8191	Atn 0	Pwr: -2.95	Diff: -2.95			
Ch: 3	DOA: 210	Freq: 8191	Atn 1	Pwr: -3.67	Diff: -2.67			
Ch: 3	DOA: 210	Freq: 8191	Atn 2	Pwr: -4.45	Diff: -2.45			
Ch: 3	DOA: 210	Freq: 8191	Atn 3	Pwr: -5.41	Diff: -2.41			
Ch: 3	DOA: 210	Freq: 8960	Atn 0	Pwr: -3.63	Diff: -2.13			
Ch: 3	DOA: 270	Freq: 8191	Atn 3	Pwr: -5.06	Diff: -2.06			
Ch: 3	DOA: 330	Freq: 8191	Atn 0	Pwr: -2.01	Diff: -2.01			
Ch: 3	DOA: 330	Freq: 8191	Atn 3	Pwr: -5.14	Diff: -2.14			
Ch: 3	DOA: 330	Freq: 8960	Atn 12	Pwr: -11.27	Diff: 2.23			
Ch: 4	DOA: 30	Freq: 767	Atn 13	Pwr: -12.03	Diff: -2.03			
Ch: 4	DOA: 30	Freq: 767	Atn 25	Pwr: -24.02	Diff: -2.02			
Ch: 4	DOA: 30	Freq: 768	Atn 3	Pwr: -2.03	Diff: -2.03			
Ch: 4	DOA: 30	Freq: 768	Atn 12	Pwr: -11.14	Diff: -2.14			
Ch: 4	DOA: 30	Freq: 768	Atn 13	Pwr: -12.03	Diff: -2.03			
Ch: 4	DOA: 30	Freq: 768	Atn 21	Pwr: -20.15	Diff: -2.15			
Ch: 4	DOA: 30	Freq: 768	Atn 22	Pwr: -21.03	Diff: -2.03			
Ch: 4	DOA: 30	Freq: 768	Atn 23	Pwr: -22.03	Diff: -2.03			

Ch	4	DOA:	30	Freq:	13311	Atn	0	Pwr:	-5.81	Diff:	2.19
Ch	4	DOA:	30	Freq:	13311	Atn	1	Pwr:	-6.79	Diff:	2.21
Ch	4	DOA:	30	Freq:	13311	Atn	2	Pwr:	-7.92	Diff:	2.08
Ch	4	DOA:	30	Freq:	13311	Atn	4	Pwr:	-9.69	Diff:	2.31
Ch	4	DOA:	30	Freq:	13311	Atn	5	Pwr:	-10.85	Diff:	2.15
Ch	4	DOA:	30	Freq:	13311	Atn	8	Pwr:	-12.76	Diff:	2.24
Ch	4	DOA:	30	Freq:	13311	Atn	9	Pwr:	-14.94	Diff:	2.06
Ch	4	DOA:	30	Freq:	13311	Atn	23	Pwr:	-28.90	Diff:	2.10
Ch	4	DOA:	30	Freq:	13311	Atn	26	Pwr:	-31.96	Diff:	2.04
Ch	4	DOA:	90	Freq:	7488	Atn	28	Pwr:	-25.69	Diff:	2.31
Ch	4	DOA:	90	Freq:	7488	Atn	29	Pwr:	-26.88	Diff:	2.12
Ch	4	DOA:	90	Freq:	7488	Atn	30	Pwr:	-27.93	Diff:	2.07
Ch	4	DOA:	90	Freq:	8960	Atn	30	Pwr:	-29.23	Diff:	2.27
Ch	4	DOA:	90	Freq:	8960	Atn	31	Pwr:	-29.94	Diff:	2.56
Ch	4	DOA:	150	Freq:	3717	Atn	4	Pwr:	-3.60	Diff:	-2.20
Ch	4	DOA:	150	Freq:	3717	Atn	5	Pwr:	-4.53	Diff:	-2.13
Ch	4	DOA:	150	Freq:	3717	Atn	6	Pwr:	-5.57	Diff:	-2.17
Ch	4	DOA:	150	Freq:	3717	Atn	7	Pwr:	-6.74	Diff:	-2.34
Ch	4	DOA:	150	Freq:	3712	Atn	4	Pwr:	-3.75	Diff:	-2.35
Ch	4	DOA:	150	Freq:	3712	Atn	5	Pwr:	-4.67	Diff:	-2.27
Ch	4	DOA:	150	Freq:	3712	Atn	6	Pwr:	-5.72	Diff:	-2.32
Ch	4	DOA:	150	Freq:	3712	Atn	7	Pwr:	-6.89	Diff:	-2.49
Ch	4	DOA:	150	Freq:	3712	Atn	13	Pwr:	-12.42	Diff:	-2.02
Ch	4	DOA:	150	Freq:	3712	Atn	16	Pwr:	-15.42	Diff:	-2.02
Ch	4	DOA:	150	Freq:	3712	Atn	17	Pwr:	-16.41	Diff:	-2.01
Ch	4	DOA:	150	Freq:	3712	Atn	18	Pwr:	-17.44	Diff:	-2.04
Ch	4	DOA:	150	Freq:	3712	Atn	21	Pwr:	-20.43	Diff:	-2.03
Ch	4	DOA:	150	Freq:	3712	Atn	28	Pwr:	-27.41	Diff:	-2.01
Ch	4	DOA:	150	Freq:	3712	Atn	30	Pwr:	-29.45	Diff:	-2.05
Ch	4	DOA:	150	Freq:	3712	Atn	31	Pwr:	-29.46	Diff:	-2.06
Ch	4	DOA:	150	Freq:	9984	Atn	0	Pwr:	-5.48	Diff:	-2.48
Ch	4	DOA:	150	Freq:	9984	Atn	1	Pwr:	-6.15	Diff:	-2.15
Ch	4	DOA:	150	Freq:	9984	Atn	4	Pwr:	-9.04	Diff:	-2.04
Ch	4	DOA:	150	Freq:	9984	Atn	5	Pwr:	-10.21	Diff:	-2.21
Ch	4	DOA:	150	Freq:	9984	Atn	6	Pwr:	-11.37	Diff:	-2.37
Ch	4	DOA:	150	Freq:	9984	Atn	7	Pwr:	-12.37	Diff:	-2.37
Ch	4	DOA:	150	Freq:	9984	Atn	9	Pwr:	-14.18	Diff:	-2.18
Ch	4	DOA:	150	Freq:	9984	Atn	10	Pwr:	-15.42	Diff:	-2.42
Ch	4	DOA:	150	Freq:	9984	Atn	11	Pwr:	-16.57	Diff:	-2.57
Ch	4	DOA:	150	Freq:	9984	Atn	12	Pwr:	-17.18	Diff:	-2.18
Ch	4	DOA:	150	Freq:	9984	Atn	13	Pwr:	-18.29	Diff:	-2.29
Ch	4	DOA:	150	Freq:	9984	Atn	14	Pwr:	-19.48	Diff:	-2.48
Ch	4	DOA:	150	Freq:	9984	Atn	15	Pwr:	-20.57	Diff:	-2.57
Ch	4	DOA:	150	Freq:	9984	Atn	16	Pwr:	-21.10	Diff:	-2.10
Ch	4	DOA:	150	Freq:	9984	Atn	17	Pwr:	-22.13	Diff:	-2.13
Ch	4	DOA:	150	Freq:	9984	Atn	18	Pwr:	-23.06	Diff:	-2.06
Ch	4	DOA:	150	Freq:	9984	Atn	19	Pwr:	-24.12	Diff:	-2.12
Ch	4	DOA:	150	Freq:	9984	Atn	20	Pwr:	-25.08	Diff:	-2.08
Ch	4	DOA:	150	Freq:	9984	Atn	21	Pwr:	-26.08	Diff:	-2.08
Ch	4	DOA:	150	Freq:	9984	Atn	24	Pwr:	-29.26	Diff:	-2.26
Ch	4	DOA:	150	Freq:	9984	Atn	25	Pwr:	-30.13	Diff:	-2.13
Ch	4	DOA:	150	Freq:	9984	Atn	26	Pwr:	-31.04	Diff:	-2.04
Ch	4	DOA:	150	Freq:	9984	Atn	28	Pwr:	-33.22	Diff:	-2.22
Ch	4	DOA:	150	Freq:	9984	Atn	29	Pwr:	-34.16	Diff:	-2.16
Ch	4	DOA:	150	Freq:	9984	Atn	30	Pwr:	-35.14	Diff:	-2.14
Ch	4	DOA:	150	Freq:	9984	Atn	31	Pwr:	-36.10	Diff:	-2.10
Ch	4	DOA:	210	Freq:	500	Atn	16	Pwr:	-15.29	Diff:	-2.29
Ch	4	DOA:	210	Freq:	500	Atn	19	Pwr:	-18.05	Diff:	-2.05
Ch	4	DOA:	210	Freq:	767	Atn	4	Pwr:	-3.15	Diff:	-2.15
Ch	4	DOA:	210	Freq:	767	Atn	13	Pwr:	-12.29	Diff:	-2.29
Ch	4	DOA:	210	Freq:	767	Atn	14	Pwr:	-13.17	Diff:	-2.17

Ch: 4	DQA: 210	Freq: 767	Atn 15	Pwr: -14.10	Diff: -2.10
Ch: 4	DQA: 210	Freq: 767	Atn 16	Pwr: -15.04	Diff: -2.04
Ch: 4	DQA: 210	Freq: 767	Atn 25	Pwr: -24.28	Diff: -2.28
Ch: 4	DQA: 210	Freq: 767	Atn 26	Pwr: -25.11	Diff: -2.11
Ch: 4	DQA: 210	Freq: 768	Atn 0	Pwr: -0.87	Diff: -2.13
Ch: 4	DQA: 210	Freq: 768	Atn 3	Pwr: -2.32	Diff: -2.32
Ch: 4	DQA: 210	Freq: 768	Atn 4	Pwr: -2.17	Diff: -2.17
Ch: 4	DQA: 210	Freq: 768	Atn 5	Pwr: -4.09	Diff: -2.09
Ch: 4	DQA: 210	Freq: 768	Atn 12	Pwr: -11.43	Diff: -2.43
Ch: 4	DQA: 210	Freq: 768	Atn 13	Pwr: -12.32	Diff: -2.32
Ch: 4	DQA: 210	Freq: 768	Atn 14	Pwr: -13.27	Diff: -2.27
Ch: 4	DQA: 210	Freq: 768	Atn 15	Pwr: -14.23	Diff: -2.23
Ch: 4	DQA: 210	Freq: 768	Atn 16	Pwr: -15.12	Diff: -2.12
Ch: 4	DQA: 210	Freq: 768	Atn 17	Pwr: -16.01	Diff: -2.01
Ch: 4	DQA: 210	Freq: 768	Atn 18	Pwr: -17.14	Diff: -2.14
Ch: 4	DQA: 210	Freq: 768	Atn 19	Pwr: -18.06	Diff: -2.06
Ch: 4	DQA: 210	Freq: 768	Atn 20	Pwr: -19.05	Diff: -2.05
Ch: 4	DQA: 210	Freq: 768	Atn 21	Pwr: -20.44	Diff: -2.44
Ch: 4	DQA: 210	Freq: 768	Atn 22	Pwr: -21.32	Diff: -2.32
Ch: 4	DQA: 210	Freq: 768	Atn 23	Pwr: -22.32	Diff: -2.32
Ch: 4	DQA: 210	Freq: 768	Atn 25	Pwr: -24.29	Diff: -2.29
Ch: 4	DQA: 210	Freq: 768	Atn 26	Pwr: -25.13	Diff: -2.13
Ch: 4	DQA: 210	Freq: 8192	Atn 28	Pwr: -31.60	Diff: -2.10
Ch: 4	DQA: 210	Freq: 8192	Atn 29	Pwr: -32.62	Diff: -2.12
Ch: 4	DQA: 210	Freq: 8192	Atn 30	Pwr: -33.71	Diff: -2.21
Ch: 4	DQA: 210	Freq: 8192	Atn 31	Pwr: -34.70	Diff: -2.20
Ch: 4	DQA: 210	Freq: 9984	Atn 31	Pwr: -36.13	Diff: -2.13
Ch: 4	DQA: 210	Freq: 10496	Atn 0	Pwr: -8.07	Diff: -2.07
Ch: 4	DQA: 210	Freq: 10496	Atn 1	Pwr: -9.09	Diff: -2.09
Ch: 4	DQA: 210	Freq: 10496	Atn 2	Pwr: -10.19	Diff: -2.19
Ch: 4	DQA: 210	Freq: 10496	Atn 3	Pwr: -11.32	Diff: -2.32
Ch: 4	DQA: 210	Freq: 10496	Atn 5	Pwr: -13.04	Diff: -2.04
Ch: 4	DQA: 210	Freq: 10496	Atn 6	Pwr: -14.13	Diff: -2.13
Ch: 4	DQA: 210	Freq: 10496	Atn 7	Pwr: -15.19	Diff: -2.19
Ch: 4	DQA: 210	Freq: 10496	Atn 13	Pwr: -21.01	Diff: -2.01
Ch: 4	DQA: 210	Freq: 10496	Atn 14	Pwr: -22.01	Diff: -2.01
Ch: 4	DQA: 210	Freq: 10496	Atn 16	Pwr: -24.32	Diff: -2.32
Ch: 4	DQA: 210	Freq: 10496	Atn 17	Pwr: -25.20	Diff: -2.20
Ch: 4	DQA: 210	Freq: 10496	Atn 18	Pwr: -26.19	Diff: -2.19
Ch: 4	DQA: 210	Freq: 10496	Atn 19	Pwr: -27.16	Diff: -2.16
Ch: 4	DQA: 210	Freq: 10496	Atn 20	Pwr: -28.10	Diff: -2.10
Ch: 4	DQA: 210	Freq: 10496	Atn 24	Pwr: -32.31	Diff: -2.31
Ch: 4	DQA: 210	Freq: 10496	Atn 25	Pwr: -33.26	Diff: -2.26
Ch: 4	DQA: 210	Freq: 10496	Atn 26	Pwr: -34.25	Diff: -2.25
Ch: 4	DQA: 210	Freq: 10496	Atn 27	Pwr: -35.22	Diff: -2.22
Ch: 4	DQA: 210	Freq: 10496	Atn 28	Pwr: -36.27	Diff: -2.27
Ch: 4	DQA: 210	Freq: 10496	Atn 29	Pwr: -37.44	Diff: -2.44
Ch: 4	DQA: 210	Freq: 10496	Atn 30	Pwr: -38.36	Diff: -2.36
Ch: 4	DQA: 210	Freq: 10496	Atn 31	Pwr: -39.36	Diff: -2.36
Ch: 4	DQA: 210	Freq: 12544	Atn 20	Pwr: -30.01	Diff: -2.01
Ch: 4	DQA: 210	Freq: 12544	Atn 24	Pwr: -34.19	Diff: -2.19
Ch: 4	DQA: 210	Freq: 12544	Atn 25	Pwr: -35.14	Diff: -2.14
Ch: 4	DQA: 210	Freq: 12544	Atn 26	Pwr: -36.20	Diff: -2.20
Ch: 4	DQA: 210	Freq: 12544	Atn 27	Pwr: -37.23	Diff: -2.23
Ch: 4	DQA: 210	Freq: 12544	Atn 28	Pwr: -38.27	Diff: -2.27
Ch: 4	DQA: 210	Freq: 12544	Atn 29	Pwr: -39.27	Diff: -2.27
Ch: 4	DQA: 210	Freq: 12544	Atn 30	Pwr: -40.19	Diff: -2.19
Ch: 4	DQA: 210	Freq: 12544	Atn 31	Pwr: -41.32	Diff: -2.32
Ch: 4	DQA: 270	Freq: 8191	Atn 26	Pwr: -28.19	Diff: -2.19
Ch: 4	DQA: 270	Freq: 8191	Atn 31	Pwr: -28.84	Diff: 2.16
Ch: 4	DQA: 270	Freq: 8960	Atn 30	Pwr: -29.40	Diff: 2.10

Ch: 4 DOA: 270	Freq: 8960	Atn	31	Pwr: -30.11	Diff: 2.39
Ch: 4 DOA: 270	Freq: 10496	Atn	28	Pwr: -36.04	Diff: -2.04
Ch: 4 DOA: 270	Freq: 10496	Atn	29	Pwr: -37.08	Diff: -2.08
Ch: 4 DOA: 270	Freq: 10496	Atn	30	Pwr: -38.19	Diff: -2.19
Ch: 4 DOA: 270	Freq: 10496	Atn	31	Pwr: -39.31	Diff: -2.31
Ch: 4 DOA: 270	Freq: 12544	Atn	28	Pwr: -38.04	Diff: -2.04
Ch: 4 DOA: 270	Freq: 14080	Atn	3	Pwr: -8.02	Diff: -2.02

END

FILMED

8-84

DTIC