

AD-A143 864

RADIO FREQUENCY DISTRIBUTION ASSEMBLY OPERATIONS AND  
MAINTENANCE MANUAL(U) SPERRY CORP CLEARWATER FL SEP 83  
SJ-8230-36063-2 N00014-82-C-2147

1/1

UNCLASSIFIED

F/G 9/5

NL

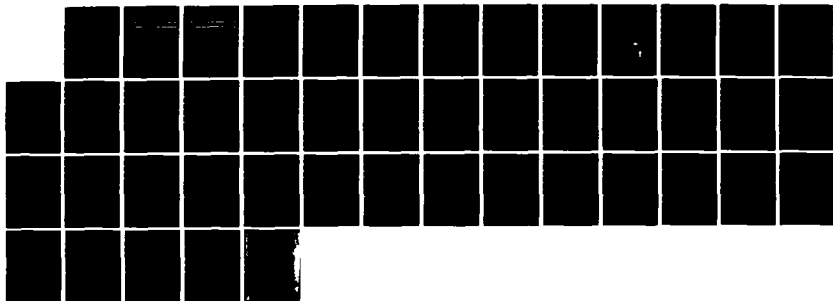

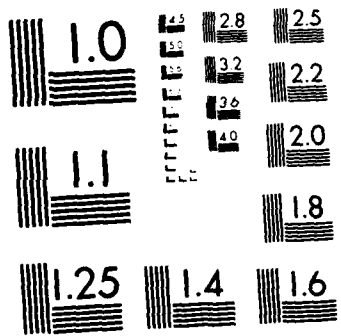

MICROCOPY RESOLUTION TEST CHART  
NATIONAL BUREAU OF STANDARDS 1963-A

AD-A143 864

(2)

**OPERATIONS AND MAINTENANCE MANUAL**

**R**ADIO

**F**REQUENCY

**D**ISTRIBUTION

**A**SSEMBLY

FILE COPY

CONTRACT NO. N00014-82-C-2147



PREPARED FOR:  
NAVAL RESEARCH LABORATORY  
WASHINGTON, D.C. 20375

SJ 8230-36063-2  
SEPTEMBER 1983

84 07 001

---

---

**OPERATIONS AND MAINTENANCE MANUAL**

---

---

**R** *ADIO*

**F** *REQUENCY*

**D** *ISTRIBUTION*

**A** *SSEMBLY*

**CONTRACT NO. N00014-82-C-2147**



**PREPARED FOR:  
NAVAL RESEARCH LABORATORY  
WASHINGTON, D.C. 20375**

**SJ 8230-36063-2  
SEPTEMBER 1983**

TABLE OF CONTENTS

<u>Section/ Paragraph</u>	<u>Title</u>	<u>Page</u>
1.0	INTRODUCTION	1
1.1	Capabilities	1
1.2	General Description	1
1.2.1	RFDA	1
1.2.2	Direction of Arrival (DOA) Channels	2
1.2.3	Power Combiners and Dividers	2
2.0	EQUIPMENT DESCRIPTION	5
2.1	RFDA	5
2.2	DOA Channels	8
2.3	Power Combiner	11
2.4	Output Power Divider	11
2.5	BIT	16
2.6	Power Supply	16
2.7	DC Distribution	19
3.0	OPERATION	25
3.1	Initial Equipment Setup	25
3.2	Normal Operation	25
3.2.1	Discussion	25
3.2.2	System Operation Procedure	27
3.2.2.1	Procedure of Operation	27
3.3	Use of the BIT	27

*Letter ref'd.* 

TABLE OF CONTENTS (continued)

<u>Section/ Paragraph</u>	<u>Title</u>	<u>Page</u>
4.0	MAINTENANCE	29
4.1	System Troubleshooting	29
4.1.1	RFDA Failure Analysis	29
4.2	Power Supply Alignment/Replacement	30.
4.3	System Recalibration	34
4.4	Maintenance Procedures	34
5.0	APPENDIX	35
5.1	List of Acronyms	35
5.2	Power Supply Assemblies	35
5.2.1	Assembly Number 16714-2	35
5.2.2	Assembly Number 16726-3	36
5.2.3	Assembly Number 16727-2	37
5.2.4	Assembly Number 16728-2	37

## LIST OF ILLUSTRATIONS

<u>Figure</u>	<u>Title</u>	<u>Page</u>
1.2-1	RFDA Block Diagram	3
1.2-2	RFDA Front Panel Layout	4
2.1-1	RFDA Functional Block Diagram	6
2.2-1	DOA Schematic	10
2.2-2	DOA Assembly	12
2.2-3	Interface Control Logic Board Assembly	13
2.3-1	Power Combiner Diagram	14
2.3-2	Power Combiner Assembly Layout	15
2.4-1	Output Power Divider Diagram	17
2.4-2	Output Power Divider	18
2.6-1	Power Supply Block Diagram	20
2.6-2	Power Supply Assembly Front Panel	21
2.6-3	Power Supply Assembly Layout	22
2.7-1	Configuration of RFDA Chassis Terminal Strips	23
2.7-2	DOA DC Voltage Terminal Strips	23
3.1-1	Initial Equipment Setup	26
3.3-1	BIT Assembly	28
4.1-1	Fault Isolation Test Matrix	31

LIST OF TABLES

<u>Table</u>	<u>Title</u>	<u>Page</u>
2.0-1	RFDA Design Parameters	7
4.1-1	LRU	30
4.2-1	DOA Power Supply Alignment	33

## 1.0 INTRODUCTION

### 1.1 CAPABILITIES

The Naval Research Laboratory (NRL) Radio Frequency Distribution Assembly (RFDA) is an interface between the Sperry four-channel, fast-switching synthesizer and the EF-111 jamming system antenna ports. The RFDA will distribute the RF energy while providing controlled RF amplitude to simulate the antenna patterns of the EF-111 Electronic Warfare (EW) systems. The RFDA is capable of operating over the frequency range of 0.5 to 18 GHz, and can rapidly switch between varying frequencies and attenuation levels.

### 1.2 GENERAL DESCRIPTION

#### 1.2.1 RFDA

The RFDA is composed of three major deliverable items:

- RFDA unit
- Power dividers
- Power supply unit.

The power supply unit consists of a separate Radio-Electronic-Television Manufacturer's Association (RETMA) rack with four drawers of supplies which provide the necessary voltages to operate the RFDA and the digital logic cards. Included in the main chassis of the RFDA is a DC distribution center.

Additional Government furnished equipment (GFE) required to operate the RFDA includes:

- Test controller
- Equipment cooling devices.

The test controller is the means by which commands are issued to the RFDA to cause the correct sequencing of the applied signal.

The RFDA has no "stand alone" capability and must be operated in conjunction with a controller.

Figure 1.2-1 is an overall system block diagram of the RFDA indicating the major subassemblies. Figure 1.2-2 shows the RF distribution assembly front panel.

### 1.2.2 DIRECTION OF ARRIVAL (DOA) CHANNELS

The RFDA unit consists of five DOA channels. Input to four of these channels comes from the banded output of the frequency synthesizer; the fifth channel is for external input. The output of the RFDA unit is taken from six power combiner subassemblies. These six outputs represent the ordinal directions of the system ( $30^\circ$ ,  $90^\circ$ ,  $150^\circ$ ,  $210^\circ$ ,  $270^\circ$ ,  $330^\circ$ ) and are a summation of all five DOA channels and a separate noise input. A built-in test (BIT) output is provided for system monitoring.

### 1.2.3 POWER COMBINERS AND DIVIDERS

The power dividers attach to the power combiners through a low-loss cable and provide multiple outputs for each ordinal direction. The six outputs of each power divider subassembly are split into two bands. One band covers the entire frequency range and the second band covers a reduced portion of the range.

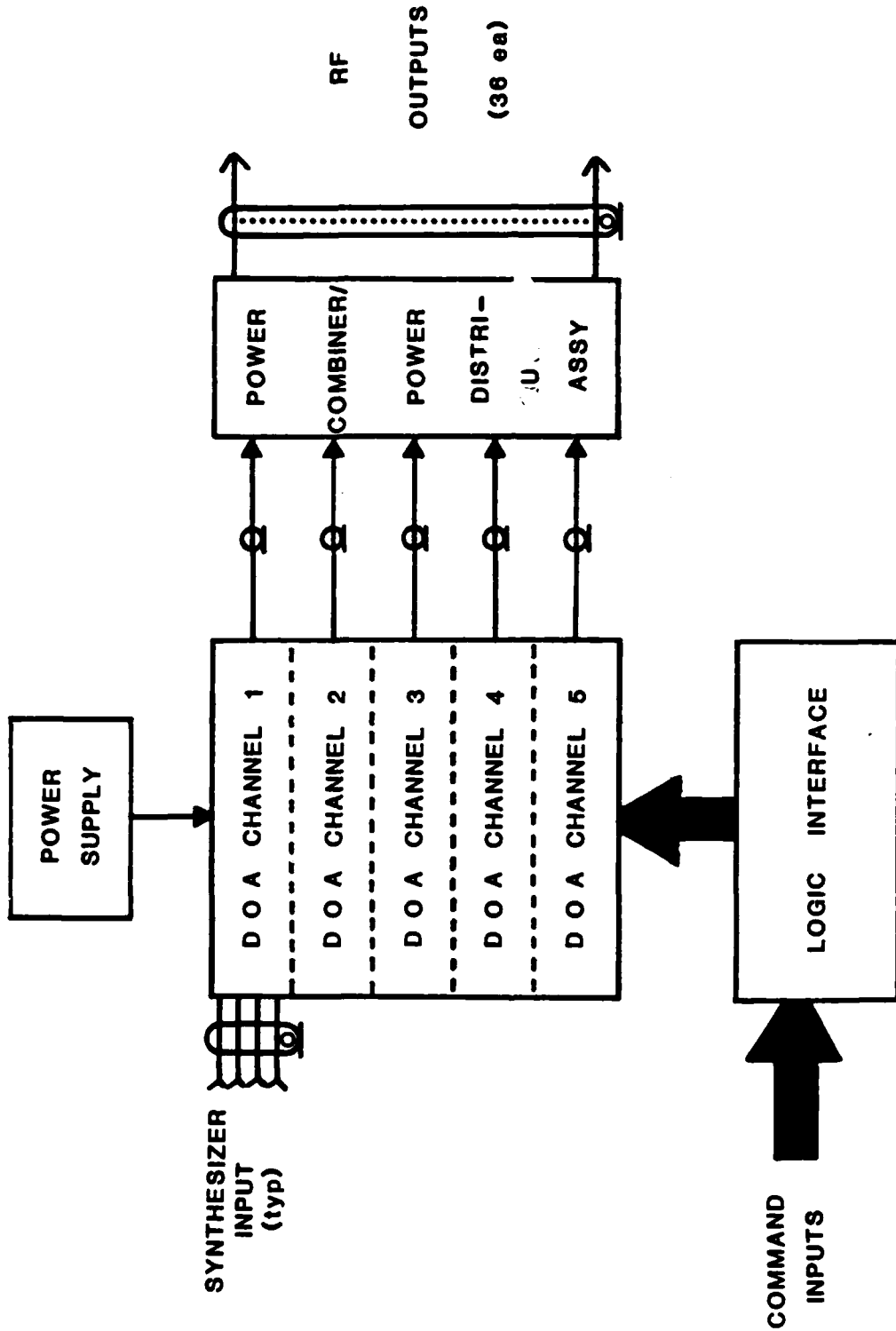

Figure 1.2-1. RFDA Block Diagram

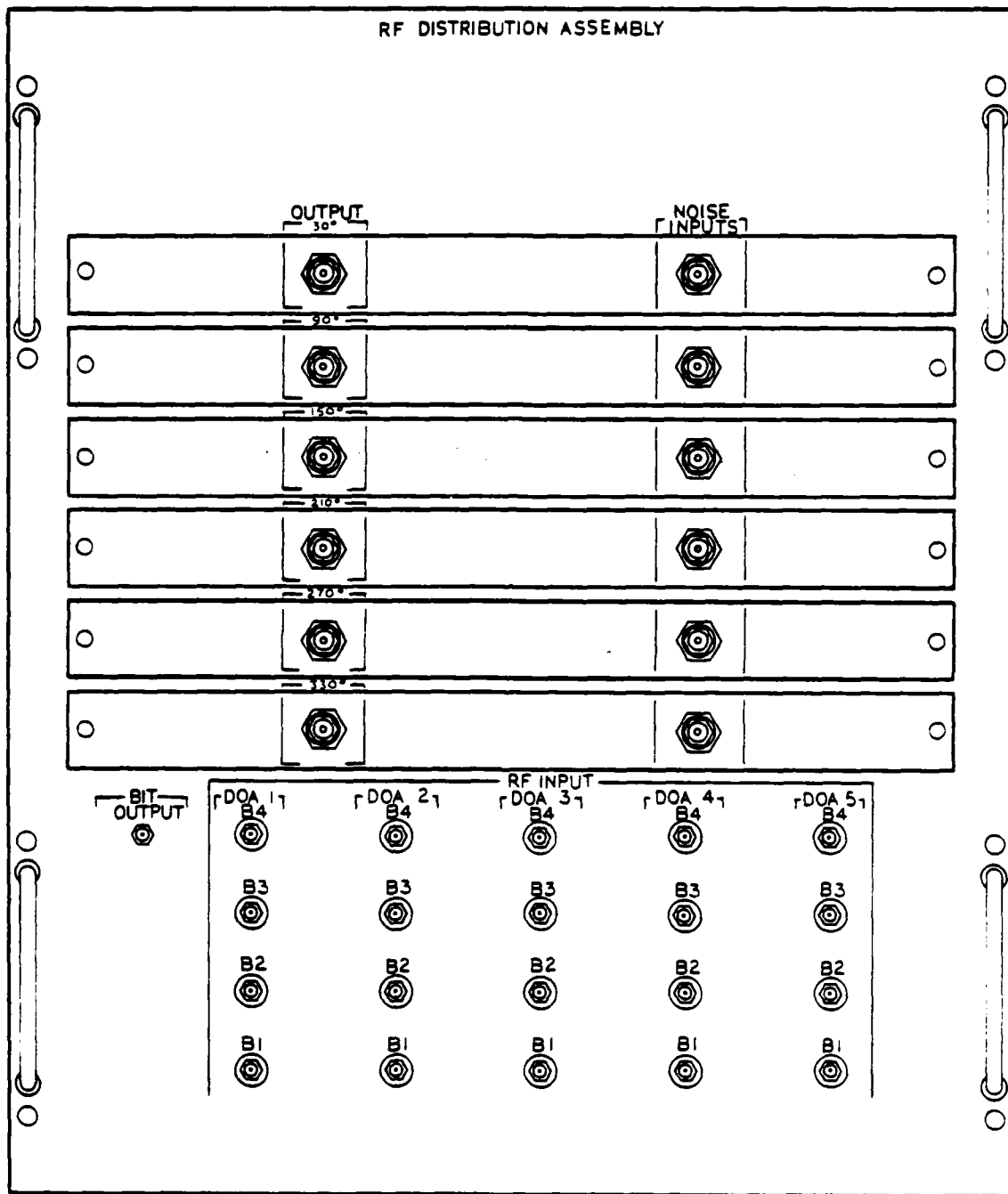

Figure 1.2-2. RFDA Front Panel Layout

## 2.0 EQUIPMENT DESCRIPTION

### 2.1 RFDA

The RFDA is a sophisticated, high-speed RF interface designed to convert the banded outputs of the four-channel synthesizer (16 ports) to 36 ports which represent six ordinal DOA for the EF-111 jamming systems. The simulation of arrival angles which appear between the ordinal directions is performed by controlling the amplitude of the RF to two DOA channels.

Figure 2.1-1 is a more detailed functional block diagram of the RFDA. This figure shows the interconnection between the power divider, power combiner and the DOA channels, along with a simple signal path in the DOA.

Table 2.0-1 lists the interface requirements and the system level RF performance specifications for the RFDA.

The RFDA system consists of the following:

- DOA channels (5)
- Power combiners (6)
- Power dividers (6)
- BIT assembly
- DC distribution
- Power supply.

Each of these areas will be discussed in turn.

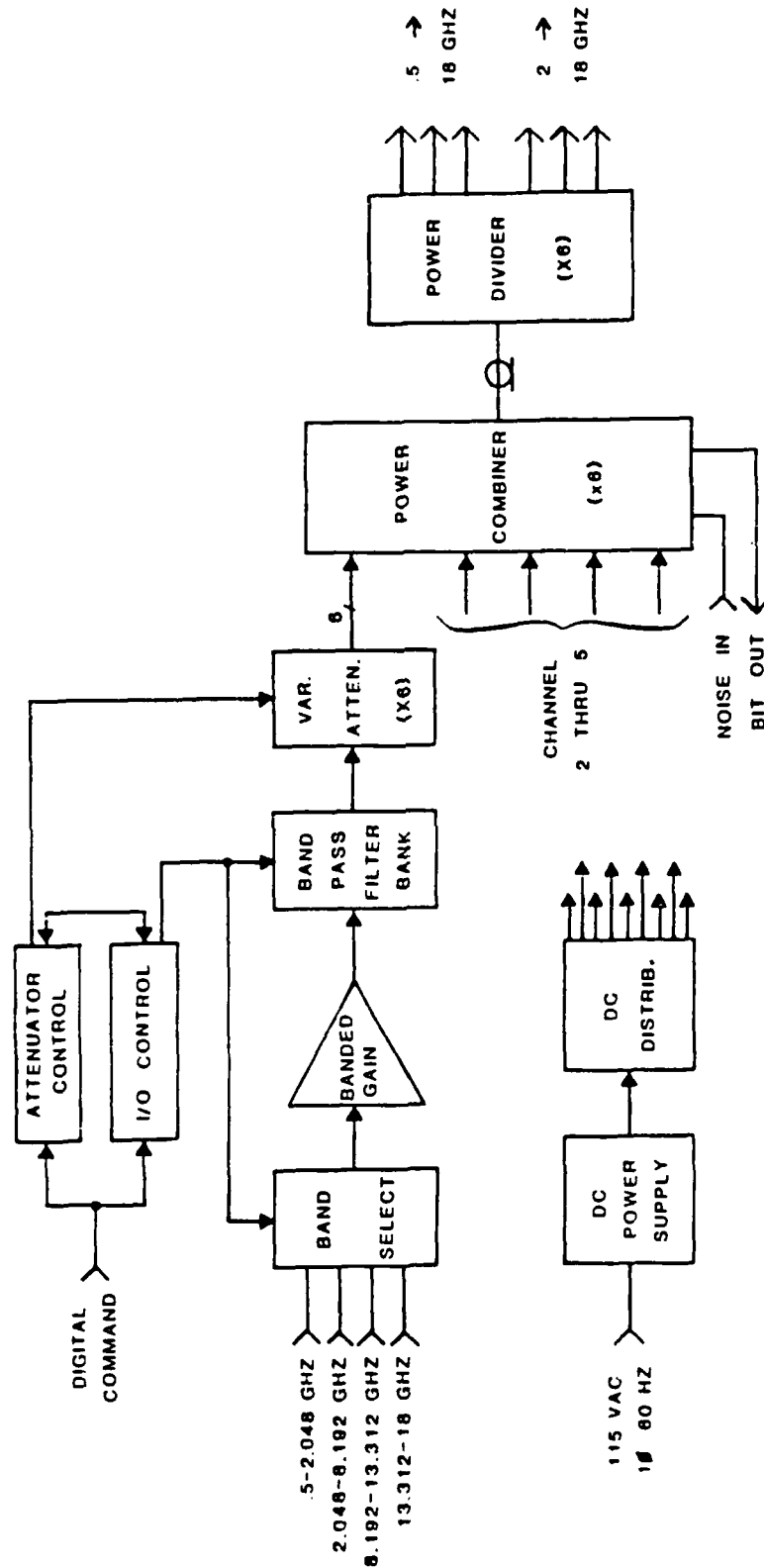

Figure 2.1-1. RFDA Functional Block Diagram

Table 2.0-1. RFDA Design Parameters

PARAMETER	PERFORMANCE
Primary power	105 - 127 Vac, 1Ø, 57 - 63 Hz
Power consumption	3.2 kVA (28 A)
Digital Interface	Unipolar Differential - balanced voltage to EIA RS-422 and Federal Standard 1020
Control signals	Differential TTL compatible with device 26LS31/26LS33
Input line receivers	Terminated in 120 $\Omega$ for transmission line matching
"True" (logic 1)	2.5 to 5.5 Vdc
"False" (logic 0)	-0.5 to +0.7 Vdc
Frequency word	9 parallel binary coded bits LSB = 64 MHz
Attenuation word	6 parallel binary coded bits LSB = 1.0 dB
Direction select	3 parallel binary coded bits
RF Performance	
° Synthesizer Input	
RF input impedance	50 $\Omega$
RF input VSWR	2.5:1 max
Maximum RF input power (damage level)	+15 dBm CW
Frequency range	0.5 to 18 GHz
° Noise Input	
Noise input impedance	50 $\Omega$

Table 2.0-1. RFDA Design Parameters (continued)

PARAMETER	PERFORMANCE
Noise input VSWR	1.7:1 max
Maximum noise input power	+10 dBm CW
° Amplitude Control	
Attenuation control	Selectable 0 - 40 dB
Attenuation resolution	1 dB step
Attenuation accuracy	±2 dB of programmed attenuation
Amplitude tracking	±2 dB channel to channel within a 128 MHz frequency step
° RF Output	
Isolation	The signal level at any port not programmed shall be isolated by 40 dB or more, relative to a selected port.
Load VSWR	No damage short to open
Output impedance	50 Ω
Output switching speed	250 ns within 1 dB of final output power
Harmonic and spurious signals	Greater than 40 dB below the fundamental signal level

## 2.2 DOA CHANNELS

Contained within the RFDA system are five identical DOA channels. Four of these channels are driven from the NRL frequency synthesizer delivered under contract N00173-80-C-0519. The fifth channel is driven from external frequency sources.

Six directions, 30°, 90°, 150°, 210°, 270°, and 330°, are output from each channel.

Figure 2.2-1 is a schematic diagram of a DOA channel. The RF input is divided into four bands:

- Band 1 0.5 - 2.048 GHz
- Band 2 2.048 - 8.192 GHz
- Band 3 8.912 - 13.312 GHz
- Band 4 13.312 - 18.000 GHz

Three amplifier bands are formed by bands 1 and 2 and the combination of bands 3 and 4. The amplifier gain was chosen such that with no programmed attenuation the output of the DOA channel would be the same as the input.

Following the amplifiers is a switched bandpass filter bank. Each filter is less than an octave wide with at least 40 dB of stopband attenuation. This, coupled with 60 dB of isolation from the switches, allows the maintenance of -40 dBc spurious and harmonic signals.

The output of the filter bank is fed to a pair of three-way power dividers which are followed by six programmable attenuators. Three of the attenuators cover the band from 0.5 to 8.5 GHz and the other three cover 7.5 to 18 GHz. Each attenuator is capable of 40 dB of attenuation above insertion loss with a minimum programmable step size of 1dB. It is the combination of these six attenuators and the switches following which performs the function of simulating the different angles of arrival and antenna patterns.

The output of the programmable attenuators is the output transfer switches. Each switch has an input from a low band and a high band attenuator. Each switch also has two outputs which are separated by 180°, i.e., the switch that controls 30° also controls 210°.

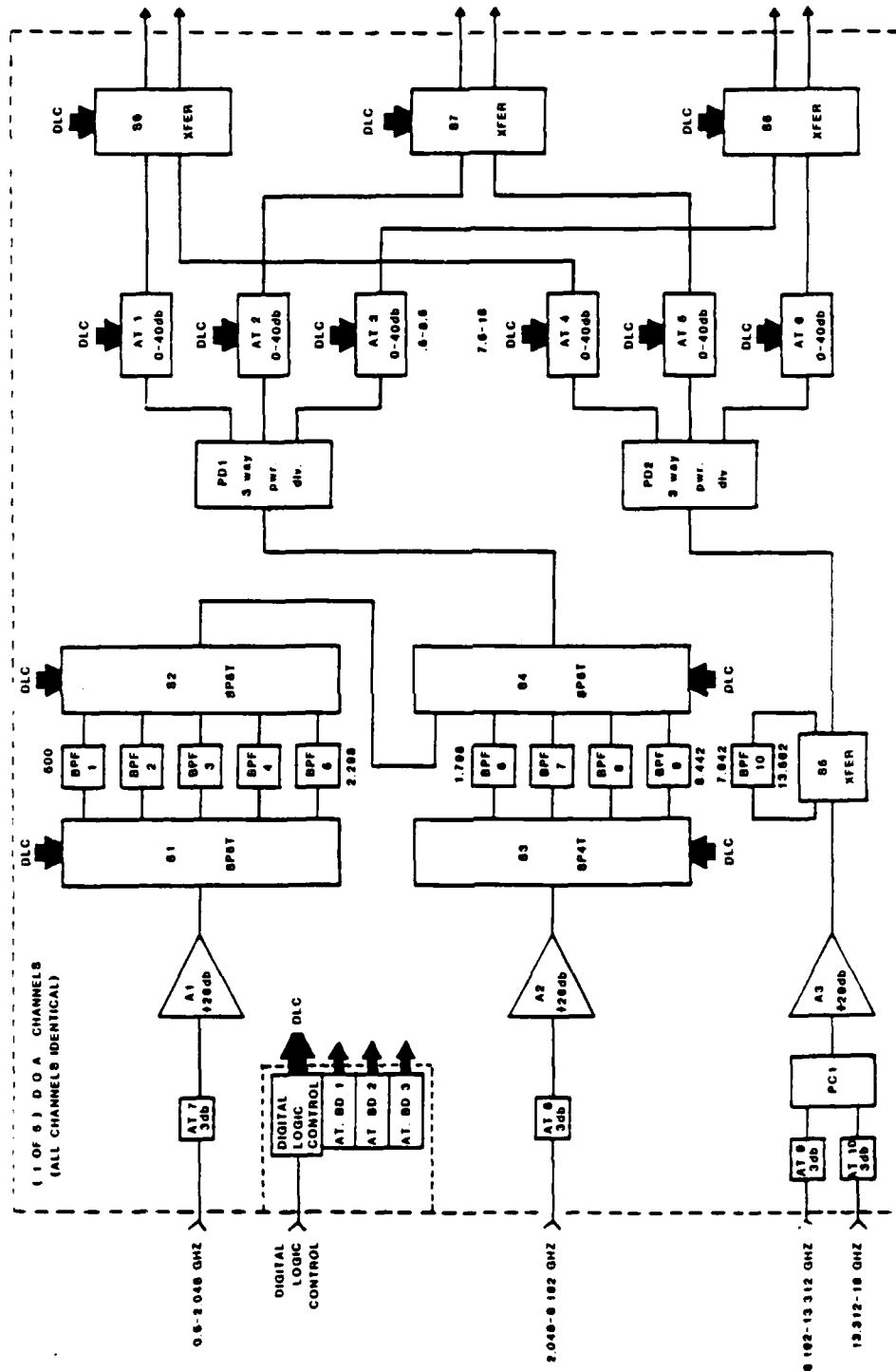

Figure 2.2-1. D0A Schematic

Each DOA channel is independently controllable from the Advanced Tactical Electronic Warfare Equipment Simulator, (ATEWES) Digital Generator Unit (DGU). The interface between the DGU and each channel is four digital logic cards. Three of the cards control the six programmable attenuators, one high-band and one low-band attenuator per card. Inputs to this card are frequency, desired attenuation, and DOA. Outputs to the attenuators are a corrected attenuation command.

The fourth card is the input/output control board. This card controls the filter bank switches, the output transfer switches and system timing. Inputs are frequency and DOA. Outputs are frequency to the attenuator boards, switch control signals, and timing signals.

Figure 2.2-2 is a drawing of the DOA assembly. Figure 2.2-3 is a layout drawing of the interface control logic board.

### 2.3 POWER COMBINER

The six outputs of each DOA channel are incorporated into six directions of arrival in the power combiners. For example, the 30° outputs of the six DOA channels are combined in a single power combiner. Figure 2.3-1 shows the schematic of a power combiner. The four inputs from the synthesizer-fed channels are combined in a single four-way divider. The input from the fifth channel and an external noise input are mixed in a two-way divider. A four-port directional coupler is used to combine the power divider outputs into a single output and also allow a sample port for the BIT output.

Figure 2.3-2 shows a power combiner assembly.

### 2.4 OUTPUT POWER DIVIDER

Included in the system are six output power dividers which receive the output signal from the power combiners. The function of the power divider is to supply to the ATEWES six outputs for each DOA. This is accomplished by

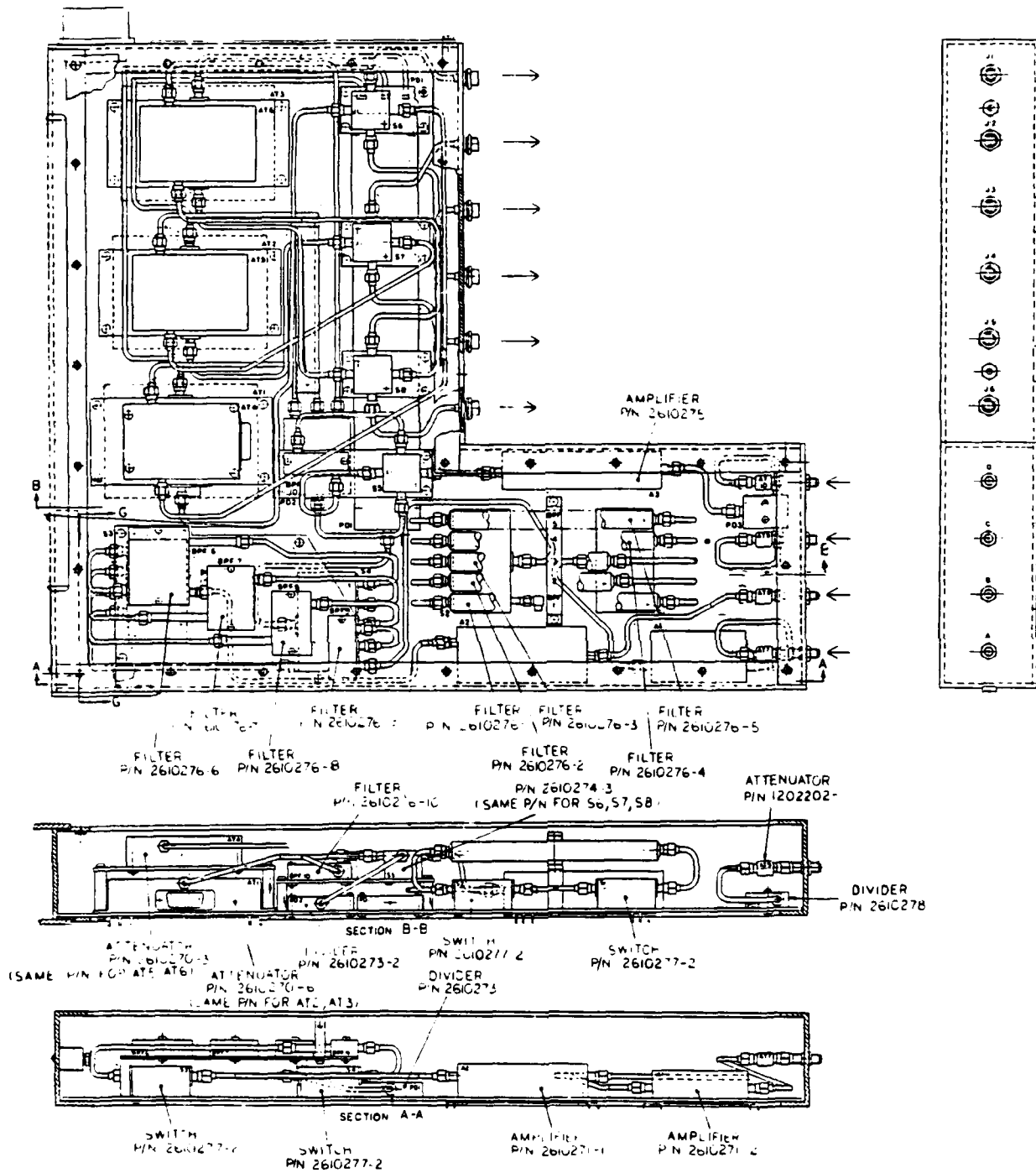

Figure 2.2.2 DOA Assembly

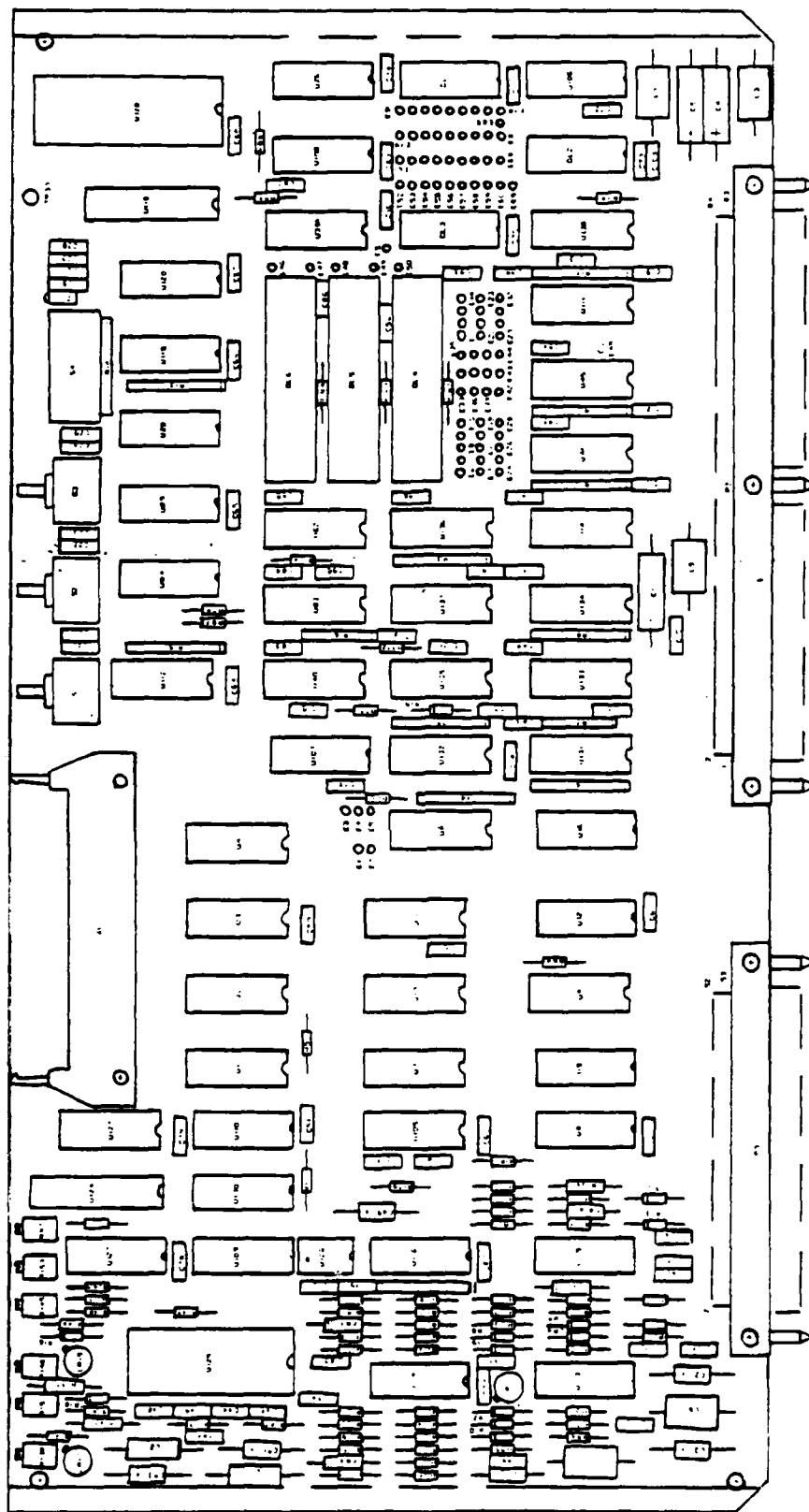

Figure 2.2-3. Interface Control Logic Board Assembly

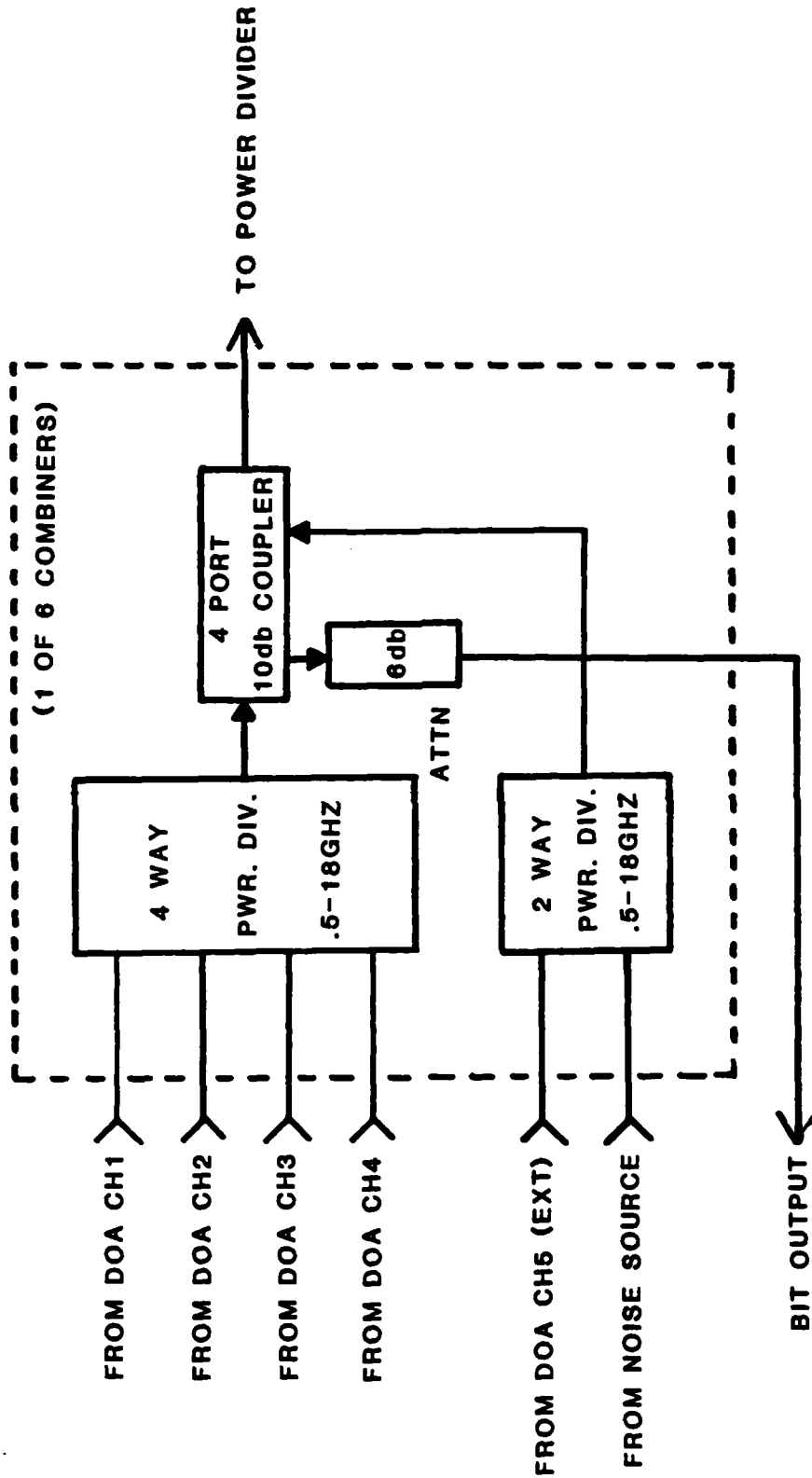

Figure 2.3-1. Power Combiner Diagram

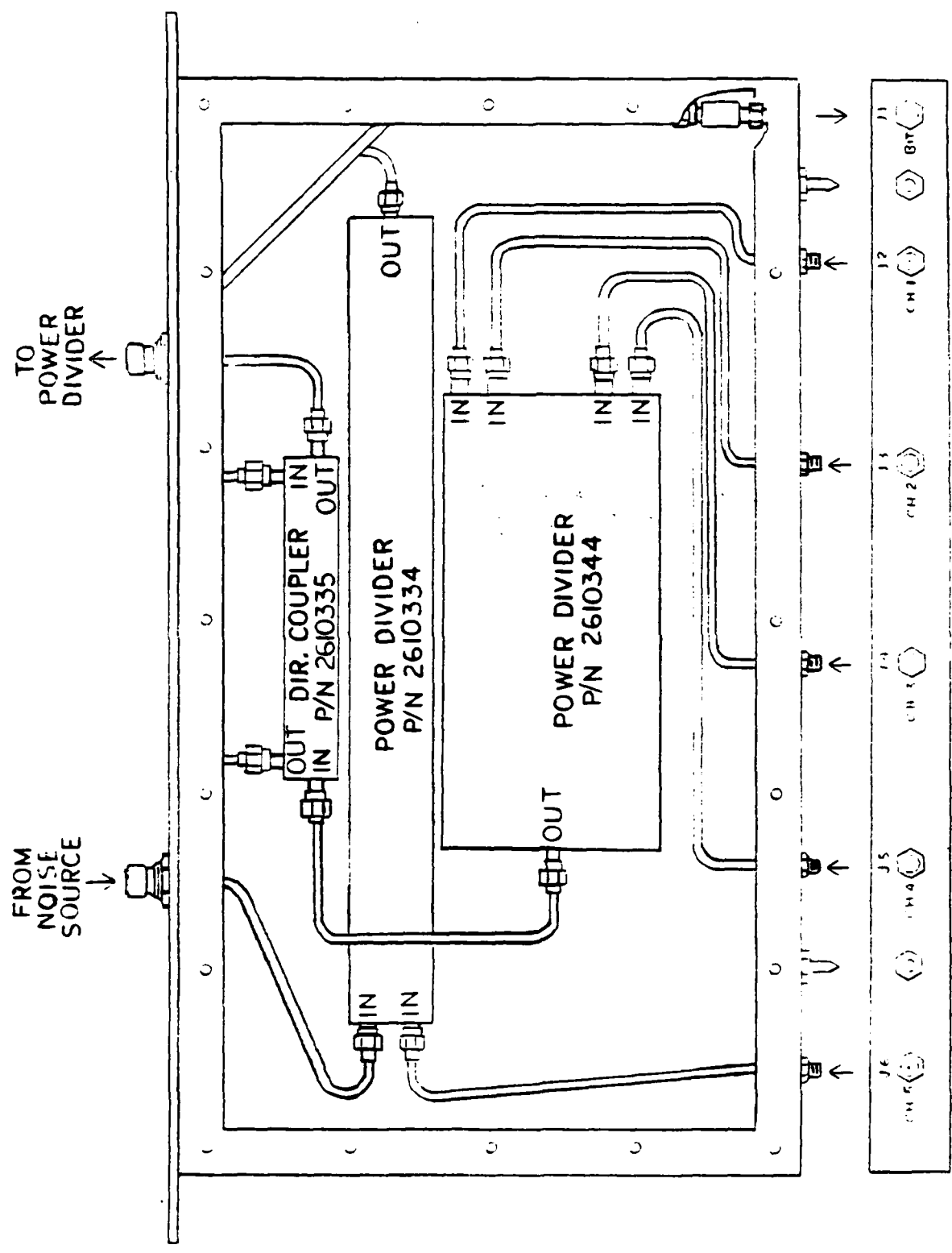

Figure 2.3-2. Power Combiner Assembly Layout

a wideband two-way power divider feeding two three-way power dividers (figure 2.3-1). One of the three-way dividers covers the entire 0.5 to 18 GHz band and the other is used for 2 to 18 GHz. Figure 2.4.1 is a schematic diagram of an output power divider. Figure 2.4.2 shows a layout of an output power divider with parts labeled.

## 2.5 BIT

An RF sample is available from each power combiner as an attenuated specimen of the signal sent to the power dividers. The six BIT outputs are brought together at a single-pole, six-throw coaxial switch. This allows the operator to choose which output to monitor.

## 2.6 POWER SUPPLY

The RFDA requires a number of different DC voltages to operate. These voltages are furnished from a separate power supply unit which consists of four drawers. Two of the drawers are used by the RF components (and the BIT switch) and the other two drawers supply the logic boards.

The power supply drawers are subdivided as follows:

RF Drawer 1:	+18V	5 ea.
RF Drawer 2:	+28V	1 ea.
	+15V	1 ea.
	-15V	1 ea.
	+5V	1 ea.
	-5V	1 ea.
Logic Drawer 1:	+5V	4 ea.
	-5V	4 ea.
Logic Drawer 2:	+15V	1 ea.
	-15V	1 ea.
	-5.2V	1 ea.
	+5V	1 ea.
	-2V	5 ea.

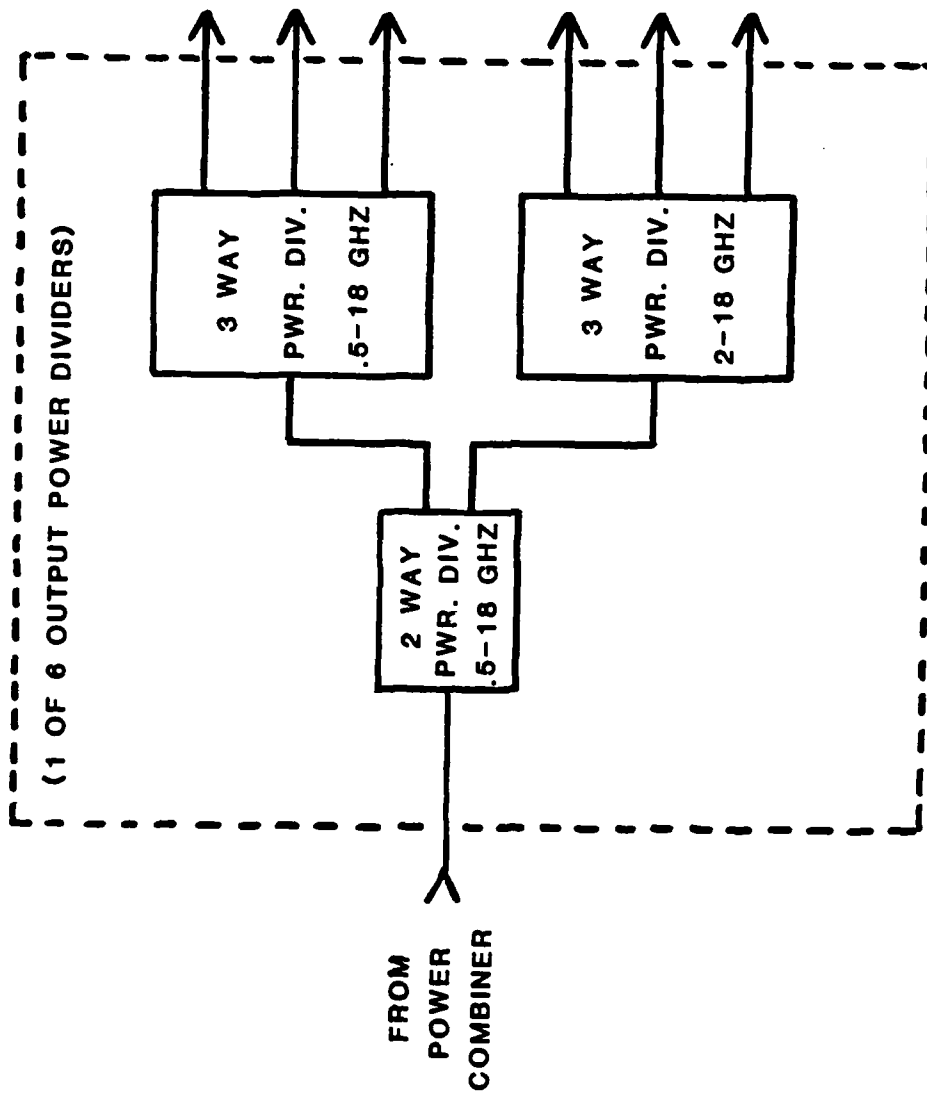

Figure 2.4-1. Output Power Divider Diagram

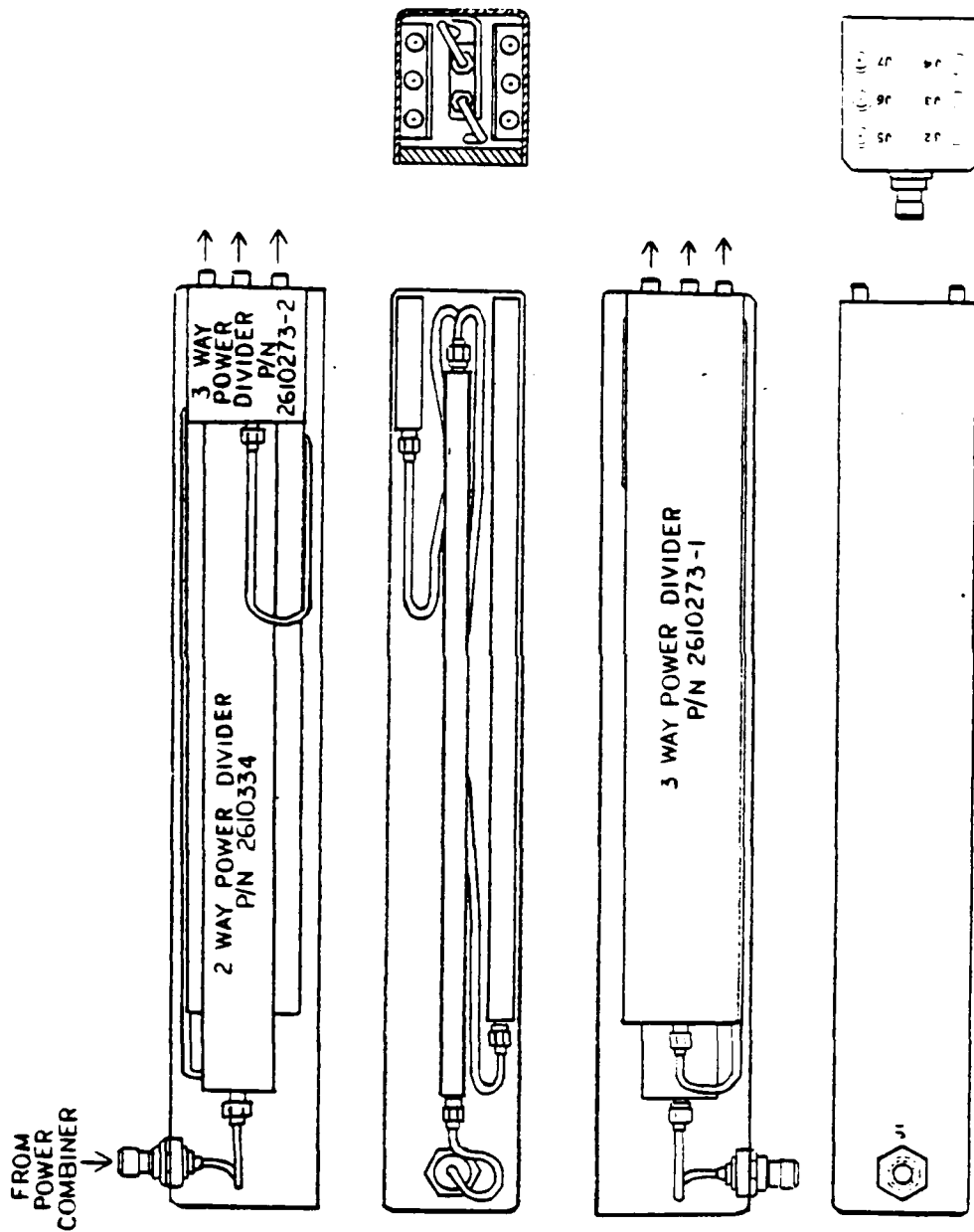

Figure 2.4-2. Output Power Divider

These power supplies are Lambda LN series, commercial quality, meeting many of the MIL specifications for temperature, shock, humidity, and vibration. Remote sensing is used to eliminate the effect of power output lead resistance on DC regulation. External overload protection automatically limits the output current to a preset value, thereby providing protection for the load and power supply. An overvoltage protection module crowbars the output when trip level is exceeded.

Figure 2.6-1 is a block diagram of the power supply input.

Figure 2.6-2 shows the power supply front panel when all four drawers are stacked for rack insertion.

Figure 2.6-3 shows a layout of all four DC power supply assemblies used in the RFDA system.

## 2.7 DC DISTRIBUTION

Distribution of voltages used within each DOA is from eight terminal strips located above the power combiners in the RFDA chassis. Figure 2.7-1 provides a sketch showing the configuration of these terminal strips.

Each DOA assembly contains two terminal strips which feed DC voltages to components respectively. Figure 2.7-2 shows the location of these terminal strips within the DOA channel.

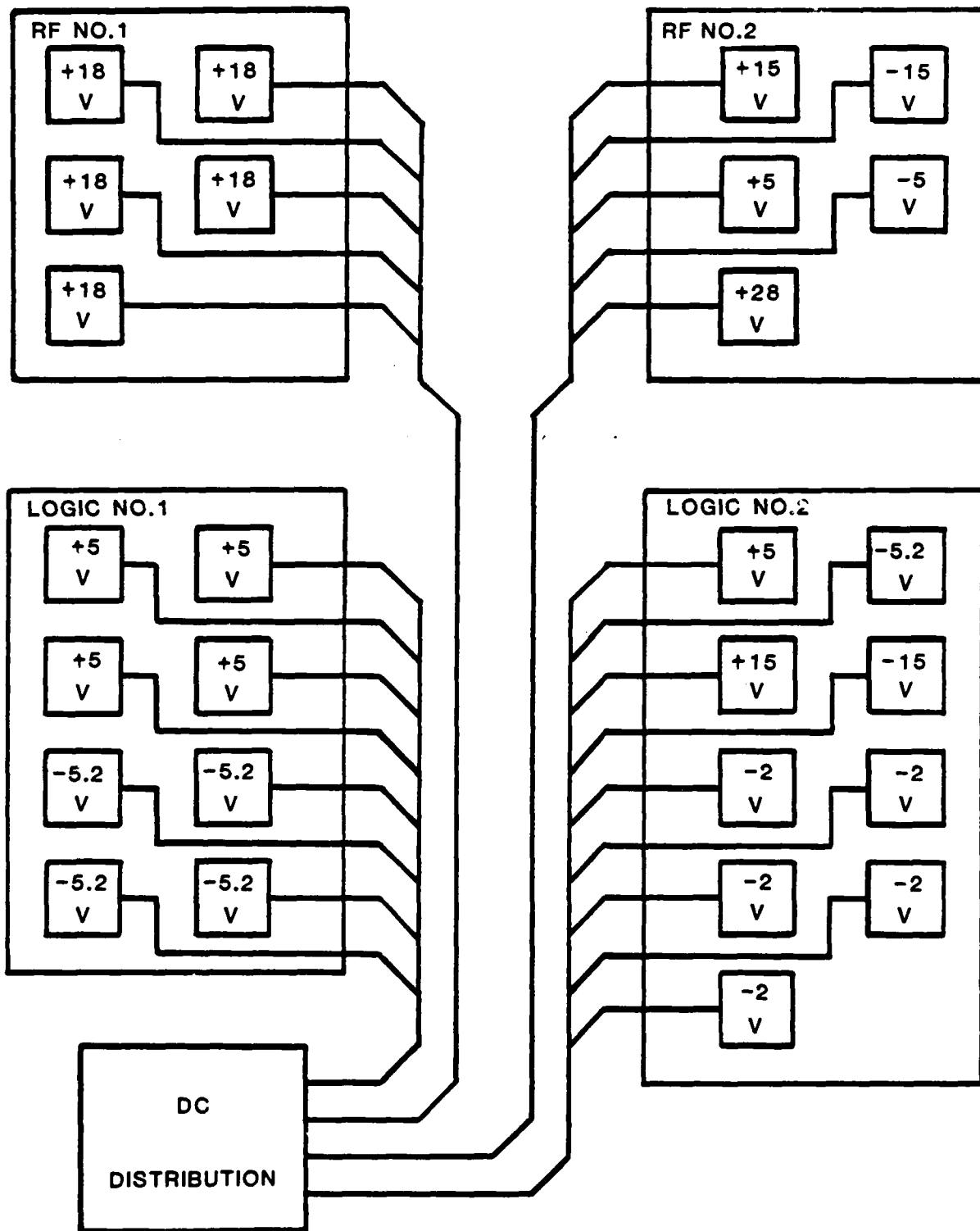

Figure 2.6-1. Power Supply Block Diagram

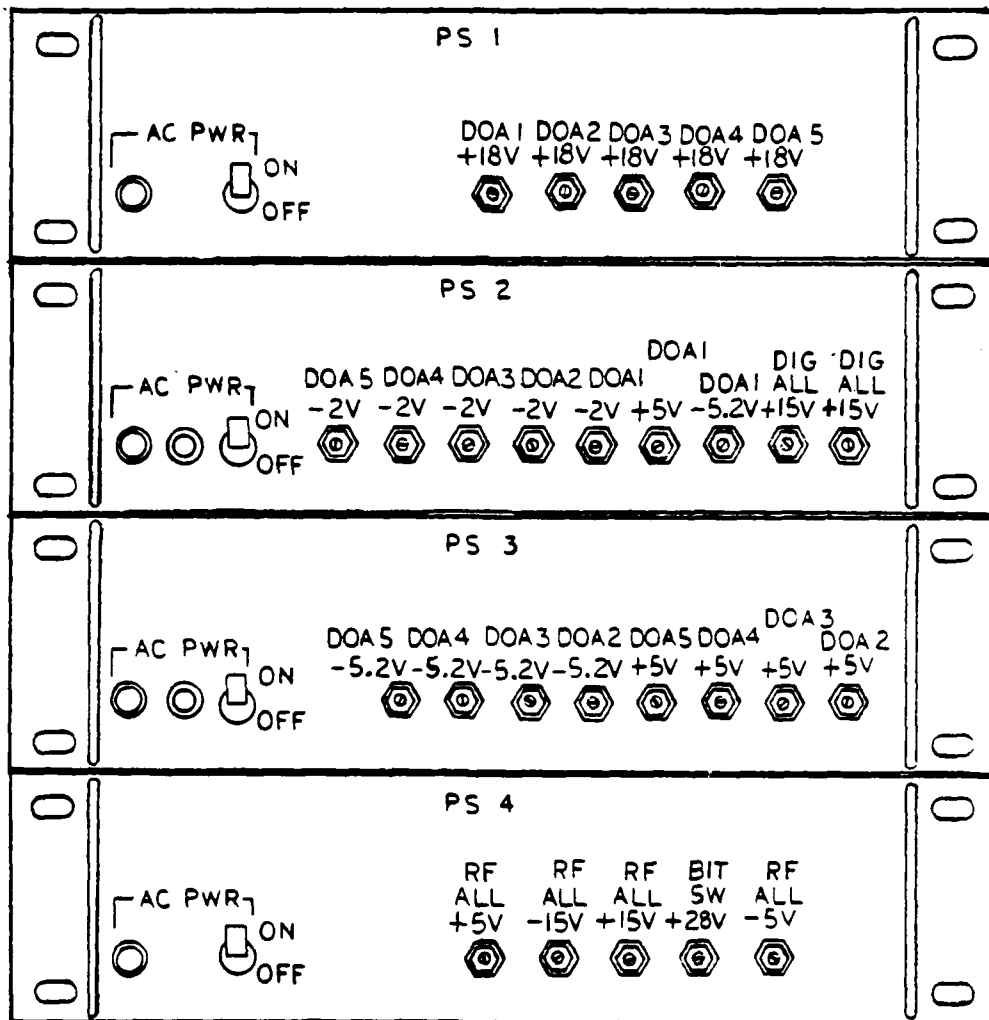

Figure 2.6-2. Power Supply Assembly Front Panel

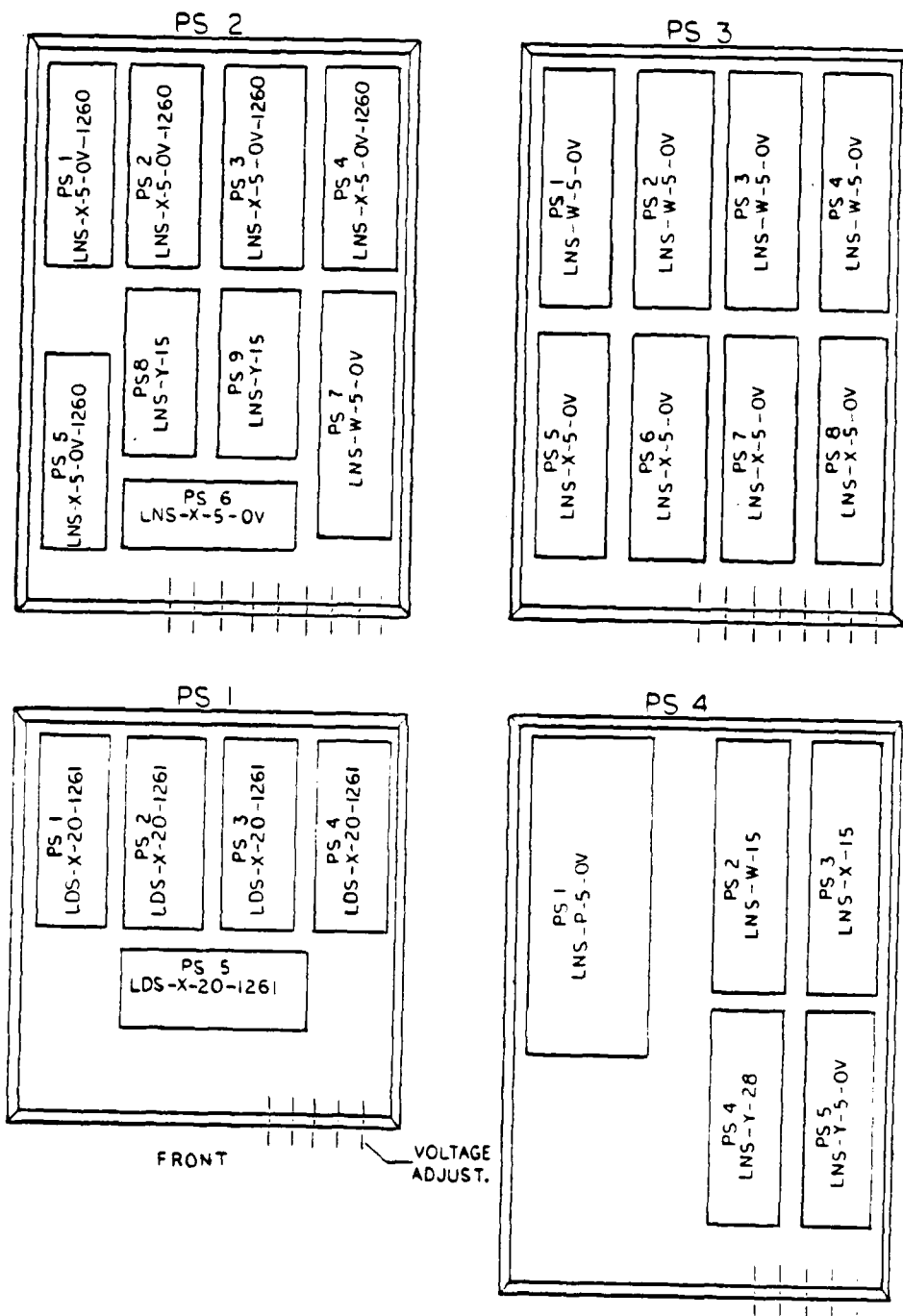

Figure 2.6-3. Power Supply Assembly Layout

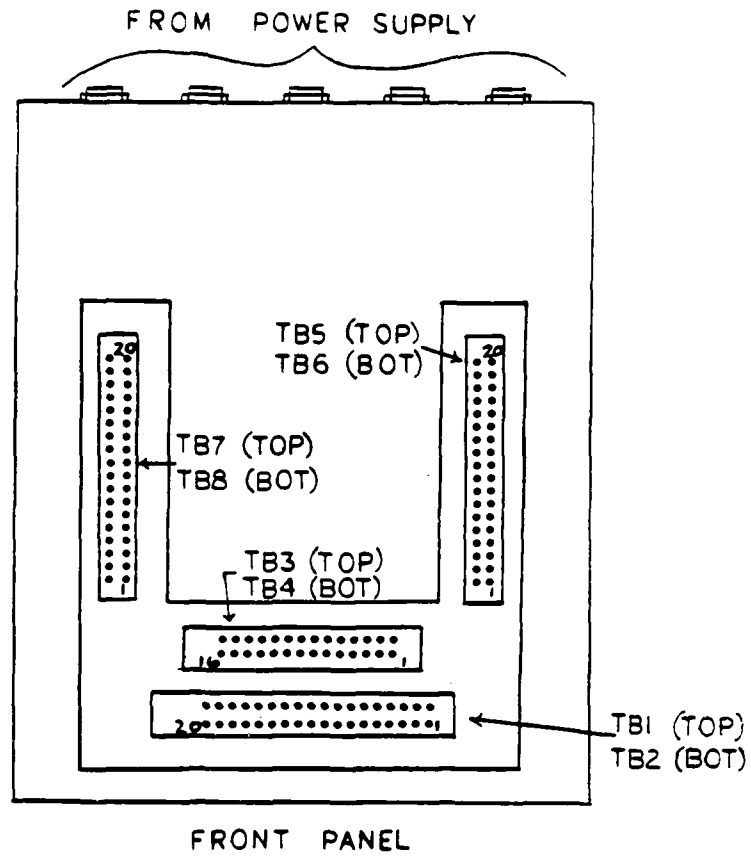

Figure 2.7-1. Configuration of RFDA Chassis Terminal Strips

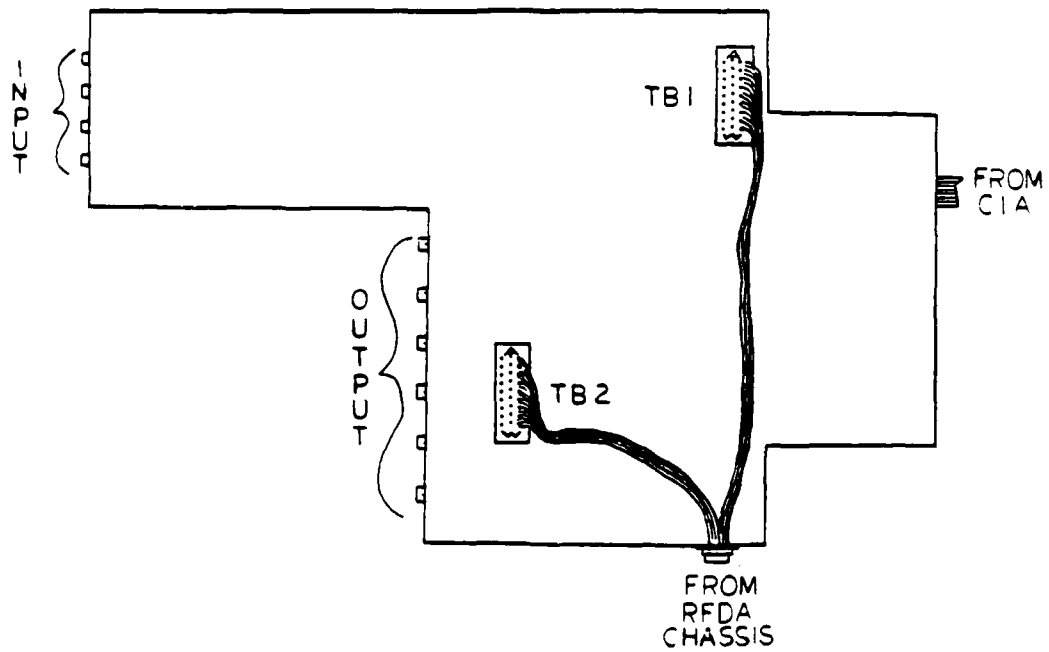

Figure 2.7-2. DOA DC Voltage Terminal Strips

## 3.0 OPERATION

### 3.1 INITIAL EQUIPMENT SETUP

The HP 9836 computer offers wide flexibility by utilizing a built-in HP-IB (IEEE-488-1978) interface. The HP-IB control language allows extensive control over the spectrum analyzer and synthesized sweeper. Graphics and alpha- numerics are transferred to hard copy via an external printer. Figure 3.1-1 shows the equipment setup required for the initial operation of the system.

A power meter is used for setup calibration. DC power is supplied to the unit under test (UUT) by the power supply assembly via the RFDA mainframe assembly. RF power is fed from the synthesizer sweeper into the appropriate input port of the UUT. The control interface assembly, which has an external 5V supply is controlled by the computer and attaches to the digital board of the UUT. RF output is channeled from the respective output port of the UUT and fed into the spectrum analyzer for automatic signal measurement. Calibrated cables are used for the RF input and RF output to maximize measurement efficiency.

### 3.2 NORMAL OPERATION

#### 3.2.1 DISCUSSION

This section is included to provide information concerning equipment turn-on and operation. A guideline for proper execution of the various RFDA capabilities is given. Since the test controller is GFE, initialization procedures for this equipment are omitted. All necessary test controller turn-on and programming will be accomplished by Government personnel.

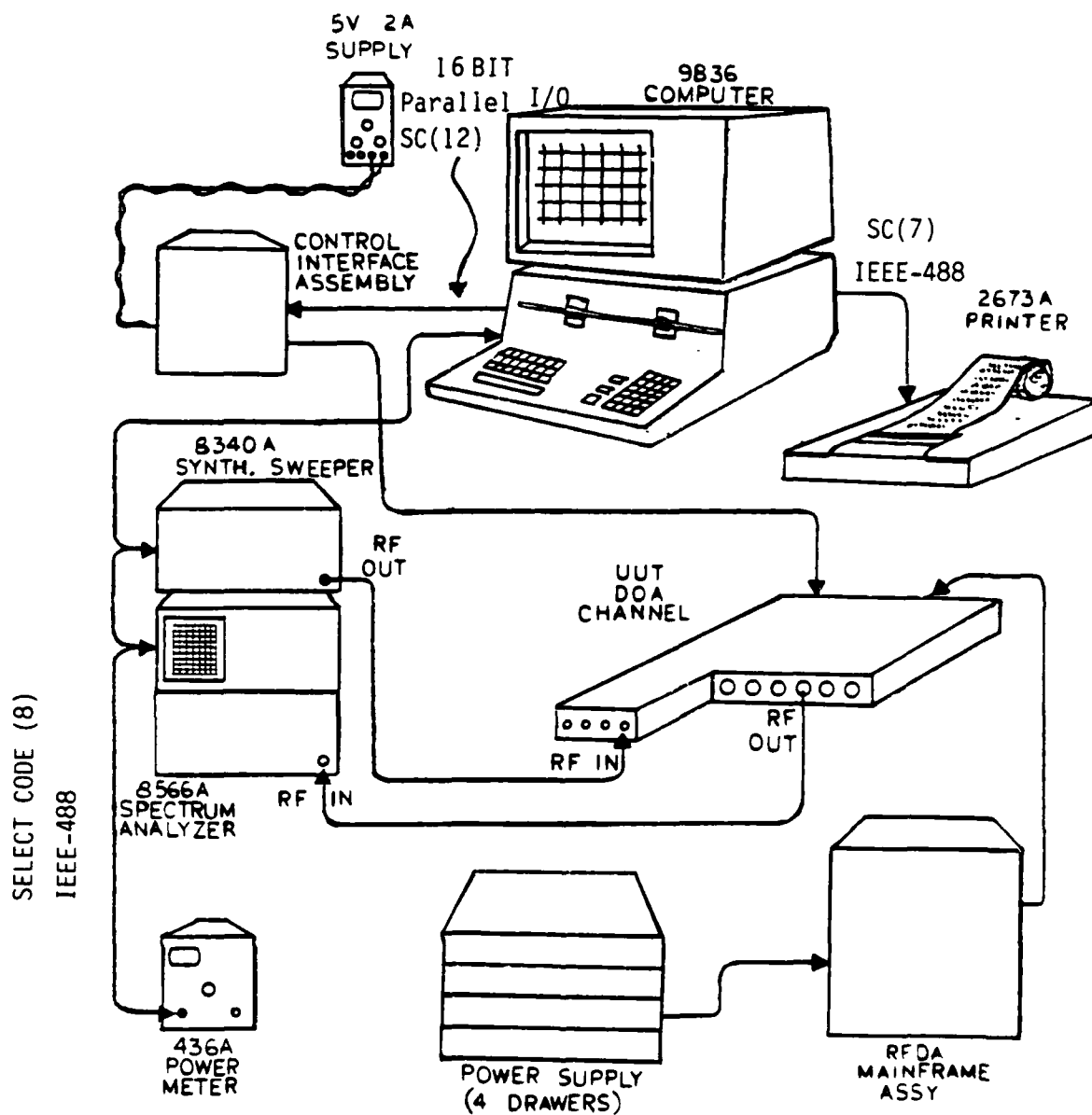

Figure 3.1-1. Initial Equipment Setup

### 3.2.2 SYSTEM OPERATION PROCEDURE

The following procedure describes general equipment turn-on and operation. Proper safety factors must be observed during operation of the system.

#### 3.2.2.1 Procedure of Operation

- 1 Apply power to all four power supply assemblies allowing a warm-up period of 5 minutes.
- 2 Turn on spectrum analyzer, allowing warm-up time of 5 minutes.
- 3 Supply frequency at the prescribed input ports of the RFDA.
- 4 Command frequency and attenuation to digital logic control cards.
- 5 Extract signal from appropriate output ports of the RFDA.

### 3.3 USE OF THE BIT

Mounted to the RFDA mainframe is the BIT assembly. The SPGT RF BIT switch, shown in figure 3.3-1a, allows an RF sample to be routed in any direction selected. The BIT output is located on the front panel as shown in figure 1.2-2. Figure 3.3-1b shows a layout of the BIT assembly digital control board which interfaces the RF switch to the system controller.

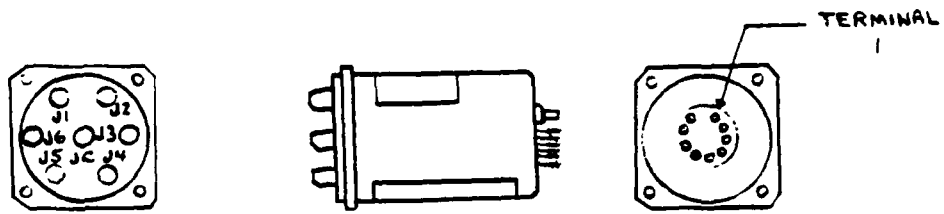

a) BIT Switch Configuration

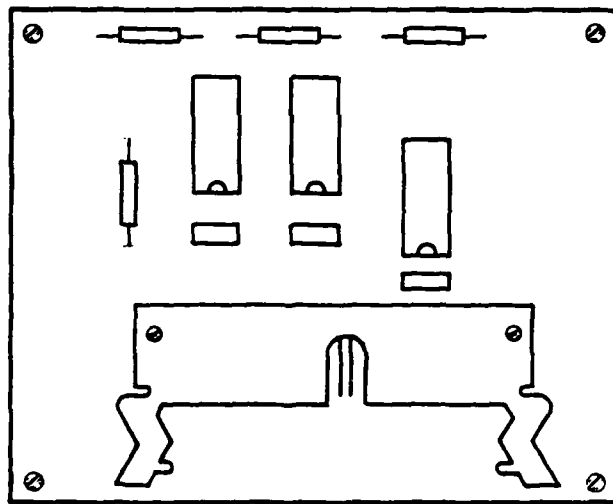

b) Digital Control Board

Figure 3.3-1. BIT Assembly

## 4.0 MAINTENANCE

### 4.1 SYSTEM TROUBLESHOOTING

This section of the manual pertains to problem analysis, fault isolation, LRU replacement and general repair. Maintenance on the RFDA is limited to LRU replacement, namely the DOA assembly, power combiner, output power divider, and individual power supplies.

The DOA assembly must be replaced as an LRU and also consists of the logic control assembly. Since this LRU is tested as a complete assembly and all calibration data is programmed in the logic control assembly, these modules must be replaced together.

When replacing the DOA assembly, it is necessary to disconnect all semirigid cable connections and the power supply cable. The logic control assembly board can be removed with the DOA assembly by separating it at the I/O connectors.

To remove the power combiner as an LRU, all coaxial cables must be disconnected. The output power divider is also an LRU and must be removed by disconnecting all external cables. In the event of a power supply failure, individual power supplies can be replaced and adjustments accomplished with minimum effort, as explained in section 4.2.

#### 4.1.1 RFDA FAILURE ANALYSIS

In the following paragraphs, a method of analyzing system failures will be presented to enable maintenance personnel to accomplish field-level repairs. The two principle failures which can be observed at the output of the RFDA are wrong frequency and no output power.

The RFDA is operated by computer control (test controller) to generate the digital commands required to perform the various tasks. For test purposes, an HP-8566A Spectrum Analyzer and an HP-436A Power Meter are used for calibration and

fault isolation. The HP-436A Power Meter is considered a standard for establishing the accuracy of the HP-8566A Spectrum Analyzer. The HP-8566A Spectrum Analyzer, after calibration, becomes the standard for all frequency and power measurements of the frequency synthesizer.

A fault isolation test matrix (figure 4.1-1) was generated to provide a means for troubleshooting system malfunctions. This fault isolation test matrix should be followed and used as a guide in maintaining the RFDA system. Table 4.1-1 provides an LRU replacement list.

Table 4.1-1. LRU

UNIT	ASSEMBLY NUMBER
DOA Assembly	2635808
Power Combiner	2635816
Output Power Divider	2635741
Power Supply 1	16714-2*
Power Supply 2	16728-2*
Power Supply 3	16727-2*
Power Supply 4	16726-3*

\*See figure 2.6-3 for individual power supply part numbers.

#### 4.2 POWER SUPPLY ALIGNMENT/REPLACEMENT

The following paragraphs provide information regarding power supply alignment and replacement. In paragraph 2.6 a general description was given of the RFDA power supply assembly which includes four drawers containing the various individual power supplies. Two of these drawers, Power Supply Assemblies 1 and 4, provide all DC voltages for the RF section of the RFDA. The other two drawers, Power Supply Assemblies 2 and 3, provide for the digital logic section of the RFDA. Pictures of these power supply drawers were provided in figure 2.6-2 and figure 2.6-3, respectively.

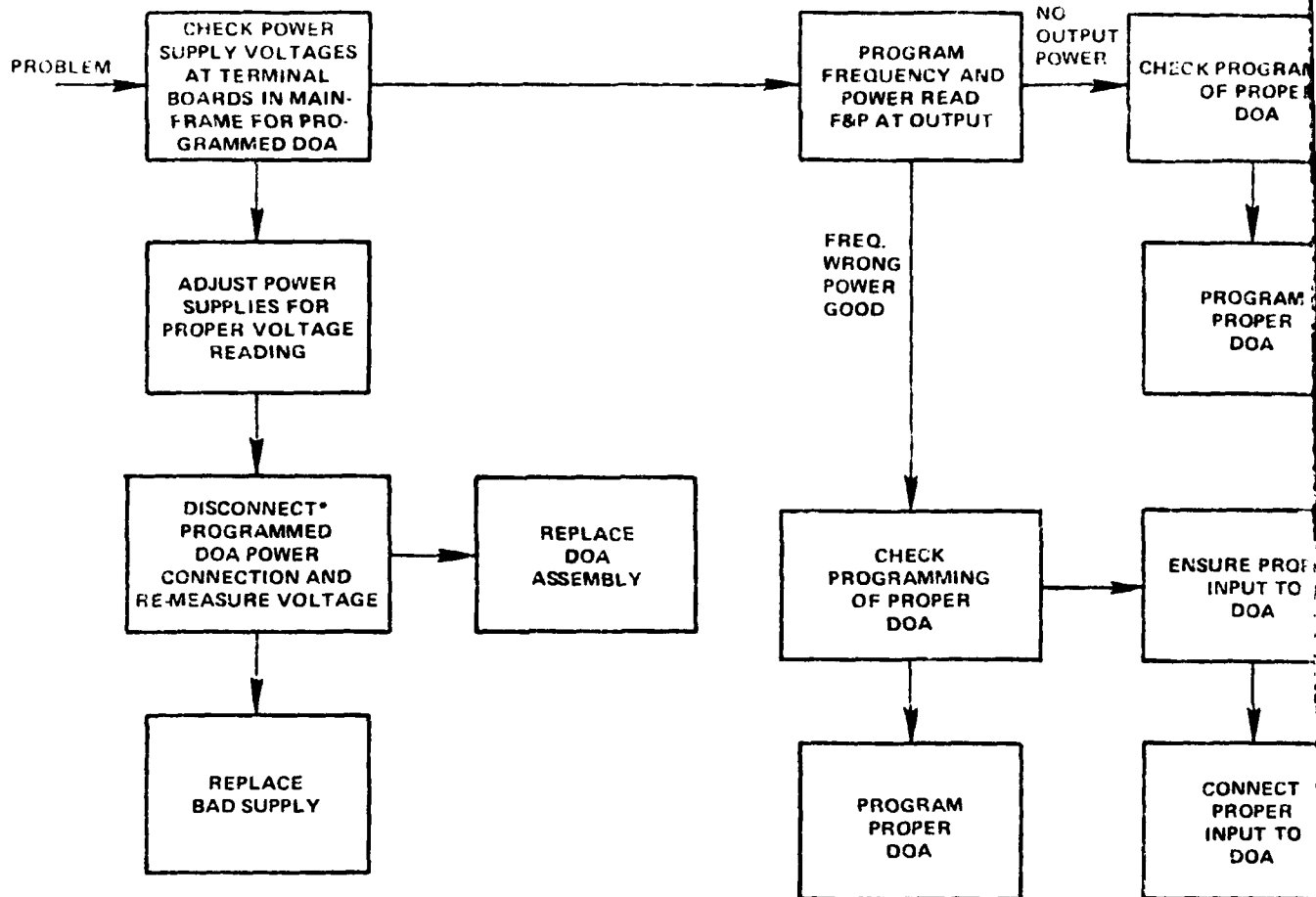

\*TURN POWER SUPPLIES OFF TO DISCONNECT POWER CONNECTION.



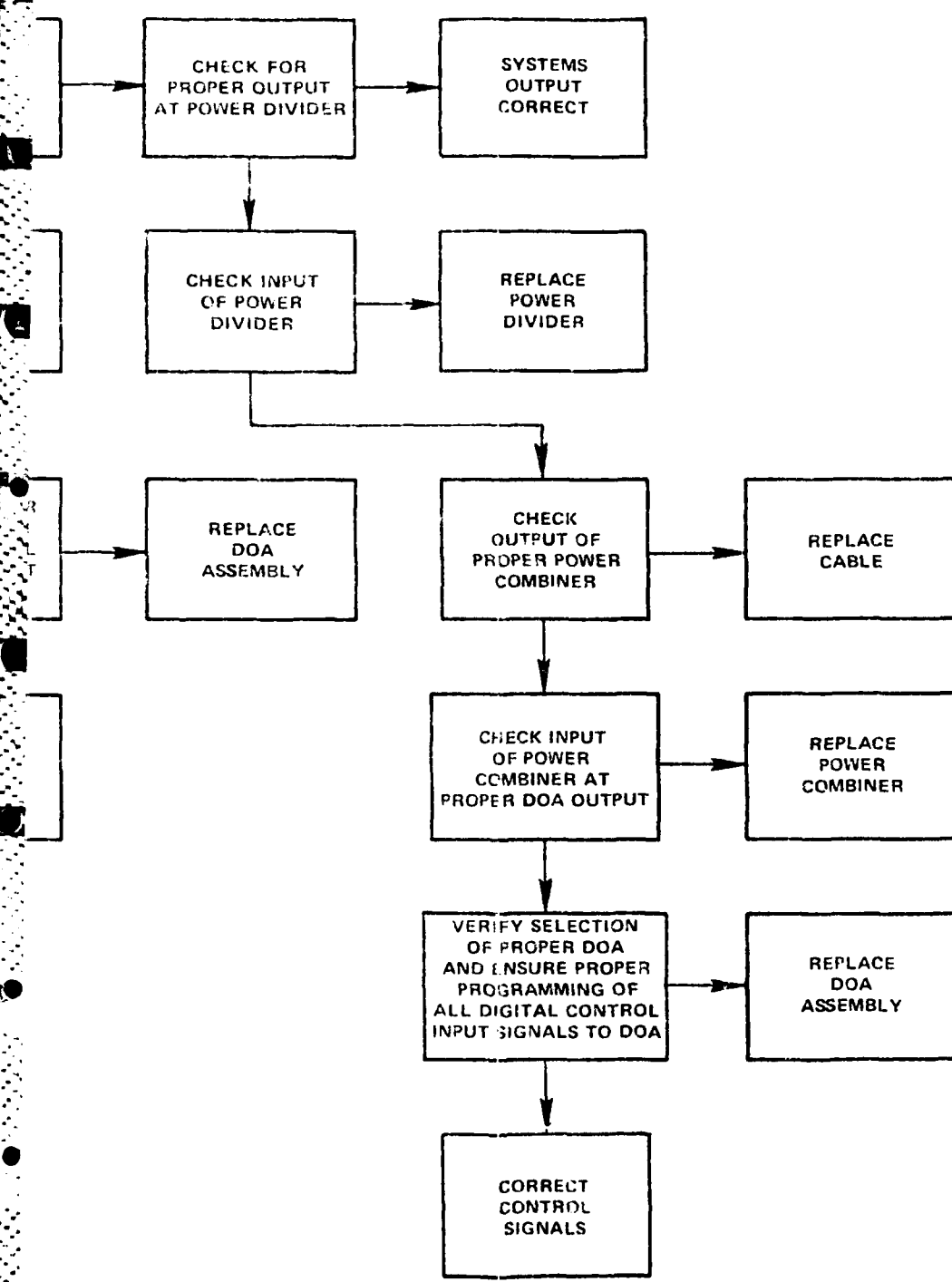

Figure 4.1-1. Fault Isolation Test Matrix

Power supply alignments for the DOA are accomplished by making voltage measurements in the DOA assembly. This method of alignment compensates for any voltage drop due to cable length. In paragraph 2.7, a description of the DC distribution was given in which figure 2.7-2 showed a layout of the DOA DC voltage terminal strips. By using the voltage readings in table 4.2-1 and the proper pin location, voltage measurements of the RF section can be performed. Individual power supply alignment is maintained by adjusting the output voltage at each power supply located on the front panel (figure 2.6-2).

When the voltage level cannot be maintained by adjusting the potentiometer on the front panel, the individual power supply must be disassembled and returned to the vendor.

Table 4.2-1. DOA Power Supply Alignment

VOLTAGE	LOCATION	READING
+15.0 Vdc	TB 2 pin B	+15.0V $\pm$ .75 Vdc
+15.0 Vdc	TB 2 pin C	+15.0V $\pm$ .75 Vdc
-15.0 Vdc	TB 2 pin H	-15.0V $\pm$ .75 Vdc
-15.0 Vdc	Tb 2 pin J	-15.0V $\pm$ .75 Vdc
-15.0 Vdc	TB 2 pin K	-15.0V $\pm$ .75 Vdc
+5.0 Vdc	TB 2 pin E	+5.0V $\pm$ .25 Vdc
+5.0 Vdc	TB 2 pin F	+5.0V $\pm$ .25 Vdc
+5.0 Vdc	TB 2 pin G	+5.0V $\pm$ .25 Vdc
+5.0 Vdc	TB 1 pin A	+5.0V $\pm$ .25 Vdc
+5.0 Vdc	TB 1 pin B	+5.0V $\pm$ .25 Vdc
+5.0 Vdc	TB 1 pin C	+5.0V $\pm$ .25 Vdc
-5.2 Vdc	TB 1 pin G	-5.2V $\pm$ .26 Vdc
-5.2 Vdc	TB 1 pin H	-5.2V $\pm$ .26 Vdc
-5.2 Vdc	TB 1 pin J	-5.2V $\pm$ .26 Vdc
-5.0 Vdc	TB 2 pin D	-5.0V $\pm$ .25 Vdc
-2.0 Vdc	TB 1 pin N	-2.0V $\pm$ .1 Vdc
-2.0 Vdc	TB 1 pin P	-2.0V $\pm$ .1 Vdc
-2.0 Vdc	TB 1 pin R	-2.0V $\pm$ .1 Vdc

Each power supply assembly is described more fully in the appendix.

#### 4.3 SYSTEM RECALIBRATION

The recalibration of the RFDA system cannot be properly conducted in the field. To ensure correct adjustments, the unit should be returned to the factory.

#### 4.4 MAINTENANCE PROCEDURES

The RFDA mainframe and power supply drawers house all components of the system in a rigidly sealed structure. Consequently, the procedures required to maintain the unit are limited to an occasional spot check of amplitude tracking. It is recommended that a factory acceptance test be performed once every six months to ensure that the unit is performing satisfactorily. Periodic cleaning of all connectors and housing is also recommended.

## 5.0 APPENDIX

### 5.1 LIST OF ACRONYMS

ATEWES	Advanced Tactical Electronic Warfare Environment Simulator
BIT	Built-in Test
CW	Continuous Wave
DC	Direct Current
DGU	Digital Generation Unit
DOA	Direction of Arrival
EW	Electronic Warfare
GFE	Government Furnished Equipment
LRU	Line Replaceable Unit
LSB	Least Significant BIT
NRL	Naval Research Laboratory
RETMA	Radio-Electronic-Television Manufacturer's Association
RF	Radio Frequency
RFDA	Radio Frequency Distribution Assembly
UUT	Unit under Test

### 5.2 POWER SUPPLY ASSEMBLIES

#### 5.2.1 ASSEMBLY NUMBER 16714-2

Lambda Assembly 16714-2 consists of the following power supplies and accessories:

LRA-15-CS	(1)	Rack adapter with chassis slides
LDS-X-20-1261	(5)	Power supplies
L-12-0V-20	(5)	Fixed hybrid 0Vs

The power supplies are mounted in the rack adapter. The AC control panel is mounted to the rack adapter and wired to the power supplies. The AC input and DC output for the entire assembly are through MS connectors mounted at the rear of the rack adapter.

The front panel is per Configuration 3 of the 1982 Lambda Catalog. The AC input connector is an MS3102A-16-10P. The DC output connector is an MS3102A-28-12S.

Assembly Number 16714-2 is referenced to Power Supply Assembly Number 1.

#### 5.2.2 ASSEMBLY NUMBER 16726-3

Lambda Assembly 16726-3 consists of the following power supplies and accessories:

LRA-17-CS	(1)	Rack adapter with chassis slides
LNS-X-15	(1)	Power supply
LNS-W-15	(1)	Power supply
LNS-P-5-0V	(1)	Power supply
LNS-Y-5-0V	(1)	Power supply
LNS-Y-28	(1)	Power supply
L-6-0V-28	(1)	Fixed hybrid 0V
L-12-0V-15	(1)	Fixed hybrid 0V
L-20-0V-15	(1)	Fixed hybrid 0V

The power supplies are mounted in the rack adapter. The AC control panel is mounted to the rack adapter and wired to the power supplies. The AC input and DC output for the entire assembly are through an MS connector mounted at the rear of the rack adapter.

The front panel is per Configuration 3 of the 1982 Lambda Catalog. Each power supply is provided with 0V protection. The AC input connector is an MS3102A-16-10P. The DC output connector is an MS3102A-32-7S.

Assembly Number 16726-3 is referenced to Power Supply Assembly Number 4.

### 5.2.3 ASSEMBLY NUMBER 16727-2

Lambda Assembly 16727-2 consists of the following power supplies and accessories:

LRA-17-CS	(1)	Rack adapter with chassis slides
LNS-W-5-0V	(4)	Power supplies
LNS-X-5-0V	(4)	Power supplies

The power supplies are mounted in the rack adapter. The AC control panel is mounted to the rack adapter and wired to the power supplies. The AC input and DC output for the entire assembly are through an MS connector mounted at the rear of the rack adapter.

The front panel is per Configuration 3 of the 1982 Lambda Catalog. The AC input connector is an MS3102A-16-10P. The DC output connector is through an MS3102A-40-9S.

Assembly Number 16727-2 is referenced to Power Supply Assembly Number 3.

### 5.2.4 ASSEMBLY NUMBER 16728-2

Lambda Assembly 16728-2 consists of the following power supplies and accessories:

LRA-17-CS	(1)	Rack adapter with chassis slides
LNS-W-5-0V	(1)	Power supply
LNS-X-5-0V	(1)	Power supply
LNS-Y-15	(1)	Power supply
LNS-X-5-0V-1260	(5)	Power supplies
L-6-0V-15	(2)	Fixed hybrid 0Vs

The power supplies are mounted in the rack adapter. The AC control panel is mounted to the rack adapter and wired to the respective power supplies. The AC input and DC output for the entire assembly are through an MS connector mounted at the rear of the rack adapter.

The front panel is per Configuration 3 of the 1982 Lambda Catalog. Each power supply is provided with 0V protection. The AC input connector is an MS3102A-16-10P. Two DC output connectors are provided an MS3102A-28-15S for the six LNS-X units and an MS3102A-24-7S for the remaining supplies.

Assembly Number 16728-2 is referenced to Power Supply Assembly Number 2.

RECEIVED