

AD-A143 988

CHARACTERIZATION OF INFRARED OPTICAL PROPERTIES OF
TRANSPARENT MATERIALS(U) CALIFORNIA UNIV LOS ANGELES
DEPT OF PHYSICS R BRAUNSTEIN 15 MAY 84
AFOSR-TR-84-0605 AFOSR-83-0169

1/1

UNCLASSIFIED

F/G 20/6

NL

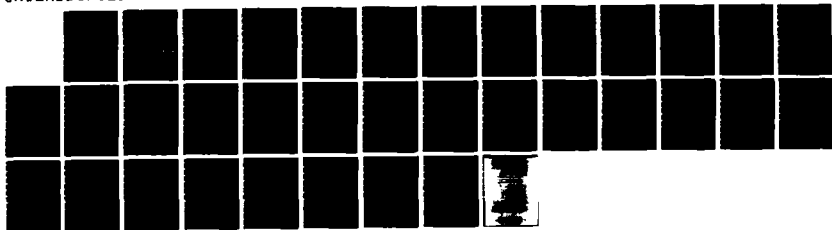

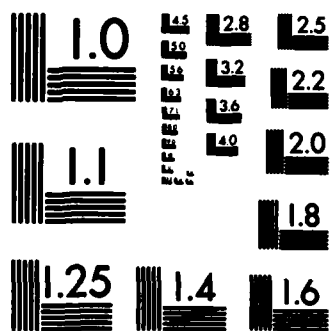

MICROCOPY RESOLUTION TEST CHART
NATIONAL BUREAU OF STANDARDS-1963-A

REPORT DOCUMENTATION PAGE

**READ INSTRUCTIONS
BEFORE COMPLETING FORM**

1. REPORT NUMBER AFOSR TR 84 0605		2. GOVT ACCESSION NO.	3. RECIPIENT'S CATALOG NUMBER
4. TITLE (and Subtitle) Characterization of Infrared Optical Properties of Transparent Materials		5. TYPE OF REPORT & PERIOD COVERED Annual Scientific Report 4/1/83-3/31/84	
7. AUTHOR(s) Rubin Braunstein		6. PERFORMING ORG. REPORT NUMBER	
9. PERFORMING ORGANIZATION NAME AND ADDRESS Department of Physics University of California, Los Angeles, CA 90024		8. CONTRACT OR GRANT NUMBER(s) AFOSR 83-0169	
11. CONTROLLING OFFICE NAME AND ADDRESS Air Force Office of Scientific Research Bolling Air Force Base, D.C. 20332		10. PROGRAM ELEMENT, PROJECT, TASK AREA & WORK UNIT NUMBERS 61102 F, 2306/R1	
14. MONITORING AGENCY NAME & ADDRESS (if different from Controlling Office)		12. REPORT DATE 5/15/84	
		13. NUMBER OF PAGES 33	
		15. SECURITY CLASS. (of this report) UNCLASSIFIED	
		15a. DECLASSIFICATION, DOWNGRADING SCHEDULE	
16. DISTRIBUTION STATEMENT (of this Report) <p style="text-align: center;">Approved for public release; distribution unlimited.</p>			
17. DISTRIBUTION STATEMENT (of the abstract entered in Block 20, if different from Report) <p style="text-align: right;">DTIC SELECTED AUG 9 1984</p>			
18. SUPPLEMENTARY NOTES			
19. KEY WORDS (Continue on reverse side if necessary and identify by block number) Ga As, Si ₃ N ₄ Raman Scattering Infrared Wavelength Modulation Strain In Semiconductors Deep Levels Photo-Induced-Transients			
20. ABSTRACT (Continue on reverse side if necessary and identify by block number) The techniques of deep level derivative absorption spectroscopy (DLDA), photo-induced-transients-spectroscopy (P.I.T.S.) were employed to study deep levels and interfaces in Ga As. Optical transitions due to impurities and structural imperfections were observed by (DLDA) which can be correlated with levels observed by (P.I.T.S.). Raman measurements were used to study changes in the surface depletion layer width of Ga As as a result of oxidizing and reducing plasma treatments; in addition, the local strain in Ga As due to various thicknesses of silicon nitride were studied by observing the shift of the LO phonon frequency.			

AD-A143 988

DTIC FILE COPY

UNCLASSIFIED

84 08 07 11Z

not side

Characterization of Infrared Optical Properties
of Transparent Materials

Contract: AFOSR 83-0169

Annual Scientific Report
for Period: 4/1/83 - 3/31/84

Submitted to:

Air Force Office of Scientific Research
Bolling Air Force Base, D.C. 20332

Accession For	
AFOSR GEN/EL	<input checked="" type="checkbox"/>
AFOSR T&B	<input type="checkbox"/>
Unprocessed	
Justification	
By	
Distribution/	
Availability Codes	
Avail and/or	
Dist Special	

D110
COPY
INSPECTED
2

Prepared by:

Rubin Braunstein

Department of Physics

University of California at Los Angeles

AIR FORCE OFFICE OF SCIENTIFIC RESEARCH
NOTICE OF REPRODUCTION RIGHTS
This report is the property of the Air Force Office of Scientific Research
and is loaned to your organization. It and its contents are not to be
distributed outside your organization without the approval of the
MATTHEW J. WILSON
Chief, Technical Information Division

Table of Contents

	Page
I. Objectives of Program	3
II. Summary of Accomplishments	4
III. Participating Scientific Personnel	7
IV. Discussion of Research Accomplishments	8
a. Deep Level Derivative Absorption Spectroscopy (DLDA)	8
b. Photo-induced and Current Transients Spectroscopy	13
c. Raman Backscattering to Determine Surface Strain and Carrier Concentration	15
V. References	20
VI. List of Figures	21
VII. Scientific Interactions	33

I. OBJECTIVES OF PROGRAM

The broad objectives of this program are to extend our understanding of the electrical properties of layered semiconductors of interest to low noise amplification, generation, and detection of high frequency radiation in large scale integrated technologies. The major techniques presently employed for the preparation of layered semiconductor materials employ some form of epitaxial growth. It is of prime importance to develop methods to rapidly assess the electric character of the substrates and the layers that are prepared, as well as follow their characteristics during various stages of processing. The aim of the present program is to develop and utilize non-contact methods for the assessment of impurities, defects, homogeneity of doping, and characterize surfaces and interfaces employing electromagnetic and electronic techniques. The techniques of infrared wavelength modulation, photo-induced-transients-spectroscopy, and Raman scattering of the UCLA group will were employed in these studies. The interactions studied have a direct bearing on dimensionally confined structure that will determine the properties of ultra-small electronic devices.

II. SUMMARY OF ACCOMPLISHMENTS

During the recent period, we have continued to direct our attention to the study of deep levels and interfaces of GaAs that are relevant to the semiconductor physics problems related to high-frequency low-noise FET devices. The techniques of infrared optical derivative, photo-induced-transient spectroscopy, and Raman scattering were used at appropriate stages of the program to develop models for deep levels and interfaces of layered semiconductors. The following summarizes progress in these areas and are described in more detail in the technical portion of this report:

1. Using our infrared wavelength modulated spectrometer that is capable of detecting a change in absorption of a part in 10^5 out of a smoothly varying background, resulting in a detection limit of $10^{12} - 10^{14}$ atoms/cm³, we have measured the absorption due to impurities and structural defects in semi-insulating GaAs. These studies were performed in the spectral region 0.1 - 1.5 eV and the temperature range 10 - 300 K. In the case of undoped LEC GaAs, we observed a number of structures due to EL2, other possible structural defects and impurity levels. Several fine structures can be interpreted in terms of intra-center transitions between residual Fe levels split by the crystal field.

2. Wavelength modulation studies of the 9 μ m region in a triple-zone refined silicon revealed several fine structures in samples with oxygen content less than 10^{16} /cm³. These structures indicate the presence of various complexes of Si-O. When the oxygen content exceeds a certain critical concentration, the dominant structure is due to Si₂O "quasi-molecules."

3. Photo-induced-transients-spectroscopy (P.I.T.S.) was performed on a range of semi-insulating substrates prepared by L.E.C., L.P.E., and M.B.E. techniques. These measurements were performed on substrates with alloy

contacts as well as on FET-like ion implanted structures. The observed energy levels varied with the technique of crystal growth. Some of the levels detected by the electrical method of P.I.T.S. are also observed optically employing our infrared wavelength modulation system using the same samples for both measurements.

In the case of doped material, current-transients techniques were used to study deep levels in ion implanted GaAs in the gate region of FET structures as well as Schottky barriers.

4. Raman backscattering was employed to study strain effects of silicon nitride layers deposited on GaAs where large interfacial strain effects were observed as a function of layer thickness and heat treatment.

5. Changes in charge carrier concentration near surfaces produced by various plasma treatments such as CF_4 , O_2 , H_2 , and SF_4 were studied by observing the shift of the screened and unscreened LO phonons by Raman backscattering

The following work has been completed appears in the following publications.

1. R. Braunstein, R. K. Kim, D. Matthews, and M. Braunstein: "Derivative Absorption Spectroscopy of GaAs:Cr," *Physica* 117B and 118B, 163 (1983).
2. M. Burd, R. Stearns, and R. Braunstein: "De-Correlation Technique for Separation of Drude Parameters from Wavelength Modulation Spectroscopy Data," *Phys. Stat. Sol. (b)* 117, 101 (1983).
3. D. Deal, M. Burd, and R. Braunstein: "Raman and Luminescence Studies of Alkali Borate Tungstate Glasses," *Journ. of Non-Crystalline Solids* 54, 207 (1983).
4. R. Stearns, J. Steele, and R. Braunstein: "Fully Electronic Servocircuitry for Wavelength-Modulation Spectroscopy," *Rev. Sci. Instr.* 54(8), 984 (1983).
5. R. K. Kim and R. Braunstein: "Infrared Wavelength Modulation Spectroscopy of Some Optical Materials," *Applied Optics* 23(8), 1166 (1984).
6. E. Eetemadi and R. Braunstein: "Deep Level Absorption Spectroscopy of Undoped GaAs," (in preparation for *Journal of Applied Physics*).

7. R. Martin and R. Braunstein: "Raman Scattering of Plasma Treated GaAs Surfaces," (planned for publication in Journal of Vacuum Science and Technology).

III. PARTICIPATING SCIENTIFIC PERSONNEL

R. Braunstein	Principal Investigator
Michael Burd	Ph.D. Candidate
M. Eetemadi	Ph.D. Candidate
R. K. Kim	Ph.D. granted June 1983. Thesis: "Infrared Wavelength Modulation Spectroscopy of Highly Transparent Solids"
Robert Martin	Ph.D. Candidate
Ward Beyerman	Ph.D. Candidate

IV. DISCUSSION OF RESEARCH ACCOMPLISHMENTS

The interactions that we have studied are in the general domain of electronic structure and lattice dynamics of semiconductors in constrained geometries of relevance to device performance with specific emphasis on GaAs. The experimental techniques of infrared wavelength modulation, photo-induced-transients-spectroscopy, and Raman backscattering, were utilized at the appropriate stages of programmatic development. The scientific approaches of the present proposal are general enough to attack a wide range of material interests in the microelectronics industry. For the present research report, we should use the format of: presenting the problem, propose an approach to a solution using a selection of the above techniques, and indicate progress.

a. Deep Level Derivative Absorption Spectroscopy (DLDA)

Problem:

Our knowledge of the point defects, such as vacancies and chemical impurities in semiconductors which give rise to substantial rearrangements of electronic density and atomic positions, is incomplete. In addition, special experimental techniques are needed to detect such defects at concentrations of 10^{12} - $10^{14}/\text{cm}^3$. These deep levels play an important role in determining many device properties.

The high mobility of GaAs which results in high device transconductance and consequently higher speed devices is stimulating the development of large scale integrated circuit technology based on GaAs which will be as important as the Si based technology. Device fabrication usually involves epitaxial growth,

diffusion processes or annealing after ion implantation which can result in deep traps in active layers and especially at layer-substrate interfaces.

Deep level defects in semiconductors are normally studied by the techniques of transient photoresponse,¹ photoconductivity,² and deep level spectroscopy.³ There exists an immense variation of junction techniques depending on the initial conditions and what parameters are finally measured.⁴ In general, excited states are not observed in these techniques, and thresholds for the transitions to bands are not easily determined. Direct absorption measurement could yield the quantities of interest, but at the levels of sensitivity of DLTS techniques, on the order of 10^{12} - $10^{14}/\text{cm}^3$, it is not possible to employ conventional optical absorption techniques.

Approach:

Deep Level Derivative Spectroscopy

We have assembled an infrared wavelength modulation spectrometer system which is capable of measuring changes in the absorption or reflection of 1 part in 10^5 in the spectral region from 0.2 - 20 μm . The system consists of a modified grating monochromator. The modulation of the wavelength is accomplished by oscillating an output diagonal mirror similar to the system employed in the visible; this method of modulation is equally good for any wavelength in the spectral range of the monochromator and the amplitude of wavelength modulation can be continuously varied by up to $\Delta\lambda/\lambda \sim 10^{-2}$. The wavelength modulation technique yields essentially the energy derivative of the absorption coefficient. To obtain the absolute value of the absorption coefficient, one numerically integrates the observed derivative spectra and the constant of integration is supplied by a direct loss measurement in the same

apparatus at a fixed wavelength where the absorption can be measured with good precision.

Figure 1 shows a block diagram of the system implementing the above operation which is under microprocessor control. The detector presently employed for the infrared is a liquid nitrogen-cooled PbSnTe with a globar source for the spectral region from 2 to 20 microns. This system can be used equally well in the ultraviolet, visible, and infrared regions with appropriate changes of sources, gratings, and detectors.

Employing our infrared wavelength modulation system which can measure absorption at levels of 10^{-5} cm^{-1} from 0.2 - 20 microns, we have investigated extrinsic absorption in GaAs for photon energies much less than the band gap. It is not necessary to make electrical contacts to the samples as in DLTS since the derivative of the direct optical absorption is measured one obviates possible contamination by thermal processing. In addition to being an optical absorption technique, we are not restricted as to the resistivity of the sample. The sensitivity of our technique is the order of 10^{12} - $10^{14}/\text{cm}^3$; in addition, excited states can be seen in optical absorption while DLTS can only measure the thermal emission rates of ground states.

Previously we had completed a detailed study of the derivative absorption of semi-insulating GaAs:Cr.⁵ The detailed extensive fine structure observed for the first time out of a previously observed smoothly varying background observed by conventional optical absorption techniques were correlated with a proposed energy level scheme of ($\text{Cr}^{3+} - \text{Cr}^{2+}$) ions in GaAs. This work indicated that a comparable number of Cr ions are at tetragonal and trigonal sites and so can explain the rapid diffusion of Cr in GaAs.

We have extended this work to undoped semi-insulating GaAs grown by LEC techniques. These studies were performed in the spectral region 0.1 - 1.5 eV

and the temperature range 10 - 300°K. In these samples, we have observed a number of structures due to EL2, other defects, and impurities. Several fine structures were observed which can be interpreted in terms of intra-center transitions between levels of impurities split by crystal field.

Figure 2 shows the absorption of semi-insulating LEC GaAs at 300 K. The threshold at 1.4 eV is the onset of the direct band-to-band transition, while the threshold at 1.0 eV is the onset of the EL2 defect. The small structure between 0.3 and 0.5 eV and threshold at 0.5 eV should be noted. The sensitivity of our measurement allows us to give credence to changes in absorption coefficient $\sim 10^{-3} \text{ cm}^{-1}$; the data were obtained with our derivative spectrometer and the integrated results are displayed. As the temperature is reduced to 160 K, we note the emergence of structure shown in Figure 3 on a vastly expanded scale. When the sample temperature is reduced to 80 K, the structure with a threshold at 1.0 eV at room temperature abruptly disappears when the sample is illuminated with band gap light; see Figure 4. When the sample temperature is increased and the measurement performed without band gap light present, the EL2 threshold returns. The metastability of this level and its possible identification as an anti-site defect of GaAs have been previously discussed.⁶

Figure 5 shows the structure observed in Figure 4 on a vastly expanded scale possible by the precision of our measurement. Note should be taken of the sharp structure at 0.36 - 0.38 eV, a broad peak at 0.4 eV, structure between 0.42 - 0.5 eV, and the threshold at 0.5 eV. Similar structures are observed in the same spectral region for other undoped LEC GaAs samples, but with changes in the relative intensities of the various structures. The structures at 0.36 - 0.38 eV and the threshold at 0.5 eV seem to be correlated, indicating they are due to the same level. The structures at 0.36 - 0.38 eV

are very similar to that which is observed for deliberately doped Fe in a number of semiconductors,⁷ and so can be identified as an intra-center transition of Fe²⁺ in GaAs. (Estimating the oscillator strength for Fe, our samples contain $\sim 10^{16}$ Fe/cm³.) The threshold at 0.5 eV whose intensity scales with this intra-center transition can be identified with a transition from the valence band to the Fe levels. This is further substantiated by the fact that the position of this threshold moves with a temperature coefficient similar to the GaAs band gap; a similar observation has been made from Hall measurements.⁸ The resonant-like band around 0.4 eV with its possible fine structure seems to be an intra-center transition. Our P.I.T.S. electrical measurements which we will discuss in a later section made on the same samples as the optical measurements reveal levels at 0.4 and 0.8 eV, the latter being due to EL2. A level at 0.4 eV has been reported in semi-insulating GaAs by a number of measurements⁹ which was originally ascribed to oxygen in O-doped GaAs. Recently a combination of temperature-dependent Hall-effect measurements, spark-source mass spectroscopy, and secondary ion mass spectroscopy measurements have indicated that neither oxygen nor any other impurity can account for the 0.4 eV level and consequently it is probably due to a pure defect.⁹ Further studies on other samples should reveal if the threshold at 0.43 is related to the resonant structure at 0.40 eV.

b. Photo-Induced-Transients-Spectroscopy (P.I.T.S.)

Epitaxial growth of semiconductor layers in most cases requires well characterized semi-insulating substrates. Deep levels in these substrates and layer-substrate interfaces influence device performance in planar devices such as field-effect transistors (FET's) and electron transfer devices (CVD's) by introducing long time constant effects. On semi-insulating material it is not possible to use the usual DLTS function techniques to study deep levels due to the large depletion layer. Consequently our photo-induced-transient-spectroscopy technique can uniquely study the electrical manifestations of deep levels in semi-insulating materials. By using our wavelength modulated system in parallel with the (P.I.T.S.) measurements, it is possible to correlate optical absorption and thermal emission states for the same defect. Photo-induced-transients-spectroscopy (P.I.T.S.) techniques involve the detection of current decay due to the emission of trapped carriers after illumination by chopped band gap light. In brief, excess electron-hole pairs are optically generated in high-resistivity semiconductors by an intrinsic light pulse. After the light pulse, a transient current due to de-trapping of carriers from deep levels can be observed between two ohmic electrodes. By studying the temperature dependence of the transient, the position of a level and its thermal emission rate can be determined. Our system is controlled by a LSI/11/23 computer which controls the light pulse, controls and varies the temperature, and digitizes the complete current transient and computers, on-line, the parameters of the deep levels.

In the case of doped material with high carrier concentration, it is difficult to measure photo-current decay as a function of temperature because of the large dark current background. In such cases one normally applies some

form of junction technique. The most popular is the D.L.T.S. method which consists in analyzing the fast capacitance transient of a reverse-pulsed junction. We have employed a transient current technique to study deep levels in doped material. The method consists in sampling the reverse current of a pulsed junction at various setting times following the application of a reverse pulse. During a scan of temperature, a series of peaks appears which provides a spectroscopic analysis of associated traps. The system implementing both techniques is shown in Fig. 6.

We have performed P.I.T.S. measurements on semi-insulating material produced by LEC growth techniques; in addition we have performed extensive measurements using our wavelength modulation techniques on adjacent samples from the same boule. We have observed persistent levels at 0.22, 0.37, 0.42, 0.5, 0.56, and 0.66 in LEC grown material from the Hughes Research Laboratory whose relative abundance varies from boule to boule. Some of these levels are also seen in L.E.P. material as well as bulk samples obtained from various vendors. The levels at 0.33, 0.42, 0.5, and 0.56 seen in the P.I.T.S. measurements seem to be correlated with the levels seen in the wavelength modulation experiments where thresholds and resonant states are also observed.

We have studied the effects of heat treatment on deep levels employing our P.I.T.S. techniques. Figure 7 shows the levels present in semi-insulating L.E.C. grown GaAs with In contacts; these levels are typical of structures seen in all L.E.C. GaAs. However, when this sample is subjected to a thermal processing there is a dramatic annealing out of a number of defects as can be seen in Fig. 8 by comparison with Fig. 7. The heat treatment is indicated in the caption of Fig. 8.

c. Raman Backscattering to Determine Surface Strain and Carrier Concentration

Problem:

Localized ion implantation into semiconductors is one of the principal techniques for fashion junctions and ohmic contacts. In GaAs FET devices, in order to have precise control of threshold voltages precise control of the implantation profile is of prime importance.

If the profile of the implanted species remained as implanted, control would be relatively simple since profiles can be predicted by "projected range statistics." However, in practice, the implanted atoms redistribute to a certain extent by diffusion during high temperature annealing which is employed to remove the radiation damage and to activate the implanted impurities. Studies of factors which influence the redistribution of the implanted species have been studied by a number of works,¹⁰ and it has been indicated that the interrelationship of radiation damage, stoichiometry in the implanted layer during implantation and annealing as well as thermal stress play a role. These studies of the redistribution profiles have usually been done by SIMS techniques. It would be desirable to have a nondestructive method of measuring the change in carrier concentration near a surface as well as stress and radiation damage.

Approach:

We have explored the use of Raman backscattering to measure the shift in frequency of the unscreened and screened phonon plasmon modes¹¹ in the depletion layer and the bulk of GaAs as a function of various surface treatments such as plasma treatment with CF_4 , SF_4 , O_2 , and H_2 as well as the deposition of silicon nitrate layers. By observing the changes in the width and the position of the LO phonon in the depletion region, inhomogeneous strains associated with lattice defects created by the plasma can be inferred. In addition, the observation of the TO phonon transition in the scattering configuration employed where it should be forbidden gives a measure of surface structural damage.

By studying the shift of the high frequency coupled L^+ mode in the bulk region beyond the depletion layer, it was possible to observe an increase or decrease of the charge carriers near the surface. In most cases we observed a charge carrier reduction presumably due to the creation of compensating defects during plasma treatment with CF_4 and SF_4 . The compensation may come in part from the complex lattice defects resulting from lattice distortion induced by exposure to ions and unradiation on impact from the complex involving impurities and vacancies. An increase in carrier concentration is observed with an O_2 plasma. The observed increase and decrease in surface carrier concentration seems to be associated with the oxidation and reducing reactions respectively due to the plasma surface interactions.

In addition the local strain in GaAs due to various thicknesses of Si_3N_4 was studied by observing the shift of the LO phonon frequency.

Change of Depletion Layer Width with Plasma Treatment

The Raman spectra were obtained with the 5145 Å Ar^+ laser line on Si-doped GaAs with $n = 1 \times 10^{18} / \text{cm}^3$, resulting in a laser penetration depth of 1000 Å and a depletion layer depth of 300 Å. Thus it is possible to observe the coupled LO-plasma modes from the bulk as well as the unscreened LO phonons from the surface depletion region simultaneously.

Figure 9 shows the Raman spectra from an untreated surface of Si implanted $n = 1 \times 10^{18} / \text{cm}^3$ GaAs. The unscreened LO phonon is seen at 289.5 cm^{-1} and the presence of the TO phonon 266.5 cm^{-1} which should be forbidden for the scattering geometry employed indicates surface damage due to the implantation. The L^+ coupled plasmon-screened LO phonon mode is seen at 497.3 cm^{-1} . The Raman peak position of the L^+ mode depends upon the bulk carrier concentration near the surface. Figure 10 shows the results for the above type of sample but treated with a SF_6 plasma excited with 25 watts for 10 minutes. The L^+ mode has shifted towards lower energy, indicating charge carrier removed near the surfaces. A range of samples was measured and it was found that in general there is an increase in carrier removal with increase in plasma power and time of exposure. In the case of an O_2 plasma, a shift to higher energy was observed which represents an addition of carriers near the surface. In addition, measurements were made of the L^+ shift with silicon nitride deposited on a $n = 1 \times 10^{18} / \text{cm}^3$ GaAs sample as a function of layer thickness. A sample with a 1750 Å layer showed a slight decrease in carrier concentration while a sample with a 3000 Å thick layer showed an increase in carrier concentration!

Strain in GaAs Due to Si_3N_4 Layers

The dotted curve in Figure 11 shows the Raman spectra from an untreated GaAs surface except for a polishing etch. The solid curve in this figure shows the spectra from a sample with a 2200 Å layer of Si_3N_4 . The substrate was Si implanted GaAs with $n = 1 \times 10^{17} / \text{cm}^3$. Both spectra show the TO and LO phonons; it should be noted that there is a shift to lower frequencies for the sample with the Si_3N_4 layer. Similar measurements were made on samples with a range of layer thickness: 500, 100, 1700, 2200 Å deposited at 25 and 200°C and a sample with 1000 Å deposited at 200°C and annealed at 950°C. In general, in most cases larger Raman shifts to lower energies were observed for increasing film thickness. However, for both the 25°C and 200°C deposited films it appears that after an initial large shift to lower energy for a 500 Å film there is decreased shift to lower energy in going to 1700 Å films. The sample with the 1000 Å deposited at 200°C and annealed at 950°C shows the least shift of all the 200°C films. In general, it is expected that the thermal stress due to Si_3N_4 on GaAs to be compressive and in the neighborhood of $\sim 10^5 \text{ nt/m}^2$ compressive stress would shift the phonon frequencies to higher energy. However, as we have observed a shift to lower energy, it would indicate that we were observing tensile rather than compressive stress! Measurements have been reported on the effects of elastic uniaxial stress on the Raman¹² and reststrahlen frequencies¹³ on GaAs. The signs of the shifts under compressive stress in general agree for these two types of measurements. However, the magnitudes of the shifts obtained in the infrared measurements are somewhat larger than in the uniaxial Raman measurements. The penetration depth of light in the Raman experiments is considerably less than in the reststrahlen experiments; this was taken as evidence for the relaxation of stress near the

surface; however, it is not clear what the details are for the stress relaxation near a surface. Our measurements, however, seem to indicate that the stress on GaAs due to Si_3N_4 indicates that the shift is tensile since the LO phonon shifts to lower energy. The penetration depth in our experiment was $\sim 1000 \text{ \AA}$, consequently the interfacial region between Si_3N_4 and GaAs that we are observing is different than one normally observes in bulk GaAs with elastic uniaxial stress.

It appears that our measurements in the Raman shifts in Si_3N_4 -GaAs layers may be revealing highly local complex stress and stress relaxation effects. It should be noted that measurements of Raman scattering from arsenic ion damaged GaAs have revealed a shift to lower frequencies with larger fluencies.¹⁴ These results have been interpreted in terms of particle size effects related to effective microcrystallite formation.¹⁵ Raman scattering from microstructures in porous Si have also revealed a shift to lower energy with finite dimensions of microstructures in the porous layers. Consequently, our measurements of the Raman shifts on Si_3N_4 -GaAs layers indicate possible formation of microcrystalline domains or "cracks" at the interface. The existence of such regions can have profound effects on the diffusion and gettering of impurities near the Si_3N_4 -GaAs interface.

V. References

1. A. Mercea, A. Muttonneau, J. Hallis, and M. Jaros, Phys. Rev. B 116, 3665 (1977).
2. E. N. Tyler, M. Jaros, and C. Panchina, Appl. Phys. Lett. 31, 208 (1977).
3. D. V. Long and R. A. Logan, J. Electron. Mater. 4, 1053 (1975).
4. D. V. Long, Thermally Stimulated Relaxation in Solids, edited by P. Braunlick (Springer-Verlag, Berlin-Heidelberg-New York), p. 93.
5. R. Braunstein, R. K. Kim, D. Matthews, and M. Braunstein, Physica 117B and 118B, 163 (1983).
6. G. M. Martin, Appl. Phys. Lett. 33(9), 747 (1981).
7. J. M. Baranowski, J. W. Allen, and G. L. Pearson, Phys. Rev. 160, 627 (1967).
8. R. W. Haisty, Appl. Phys. Lett. 7, 208 (1965).
9. D. C. Look, S. Chaudhuri, and J. R. Sizelove, Appl. Phys. Lett. 42(9) (1983).
10. J. Kasahara and N. Watanabe, Appl. Phys. Lett. 38, 798 (1981).
11. G. Abstreiter, E. Bauser, A. Fisher, and K. Ploog, Appl. Phys. 16, 345 (1978).
12. F. Cerdeira, C. J. Buckenauer, Fred H. Pollak, and Manuel Cardona, Phys. Rev. B 5, 580 (1972).
13. B. A. Weinstein and M. Cardona, Phys. Rev. B 5, 3120 (1972).
14. F. H. Pollack, P. M. Amirthoray, and K. K. Tiong, Bulletin of APS, March 1983, Los Angeles, p. 282.
15. M. B. Stern, P. Beck, and P. F. Liao, ibid., p. 281.

VI. LIST OF FIGURES

- Fig. 1. Infrared Wavelength Modulation System.
- Fig. 2. Wavelength Modulation Absorption Spectra for SI-GaAs(LEC)-MO39T at
T = 300 K.
- Fig. 3. Wavelength Modulation Absorption Spectra for SI-GaAs(LEC)-MO39T at
T = 160 K.
- Fig. 4. Wavelength Modulation Absorption Spectra for SI-GaAs(LEC)-MO39T at
T = 80 K.
- Fig. 5. Expanded Scale of Fig. 4.
- Fig. 6. Photo-Induced and Current Transients System.
- Fig. 7. P.I.T.S. Spectra of SI-GaAs(LEC)-MO39. Unannealed.
- Fig. 8. P.I.T.S. Spectra of SI-GaAs(LEC)-MO39. Annealed for 4 hours at
700 K.
- Fig. 9. Raman Spectra from Si-Implanted GaAs, $n = 1 \times 10^{18}/\text{cm}^3$ untreated
surface.
- Fig. 10. Raman Spectra from Si-Implanted GaAs, $n = 1 \times 10^{18}/\text{cm}^3$ treated with
 SF_6 plasma at 25 watts for 10 minutes.
- Fig. 11. Raman Spectra:
(a) Solid Curve - GaAs with 1700 Å Layer of Si_3N_4 on a $n = 1.2 \times 10^{17}/\text{cm}^3$
Si Implant.
(b) Dotted Curve - Untreated GaAs in Above Substrate - no Si_3N_4 Layer.

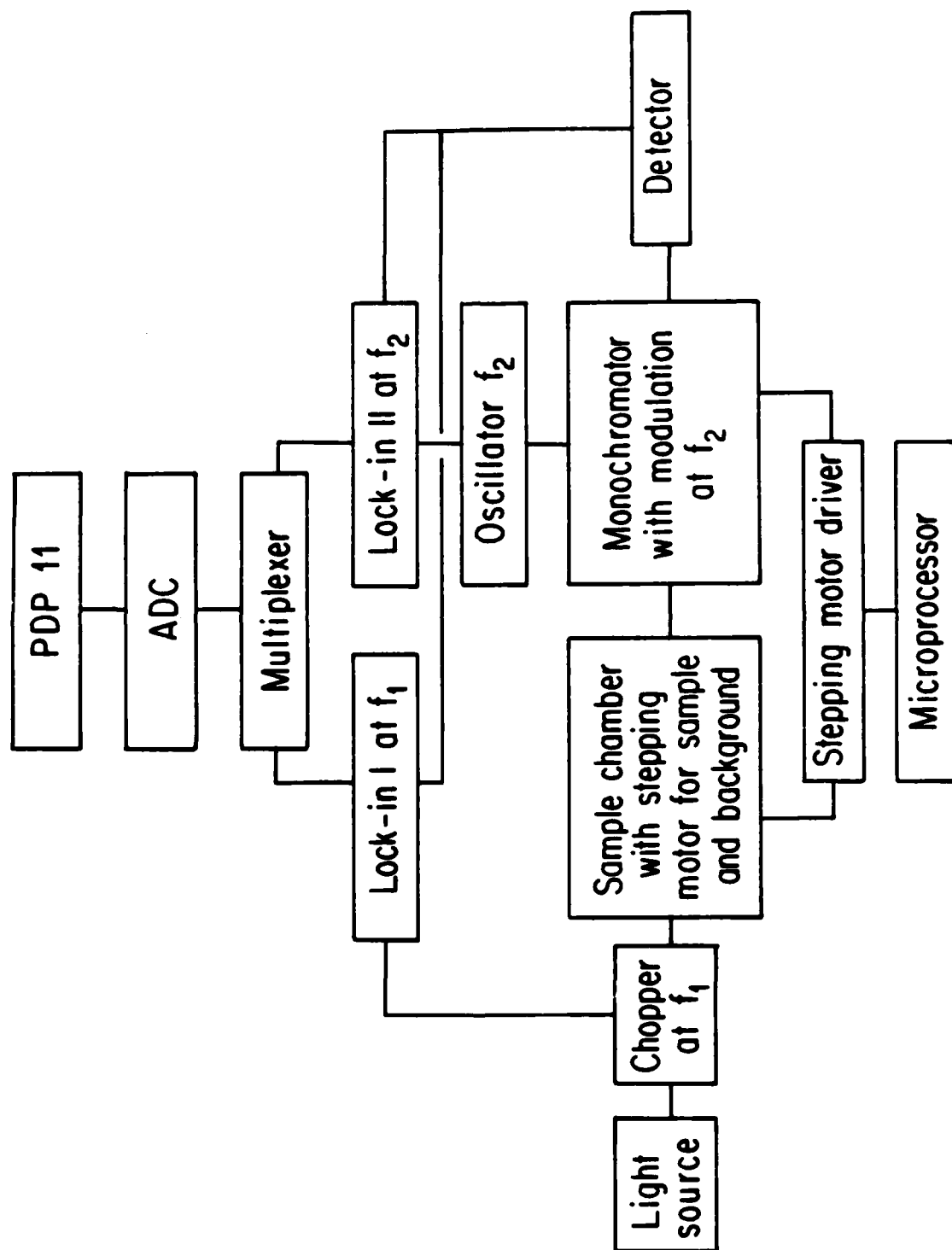

Fig. 1

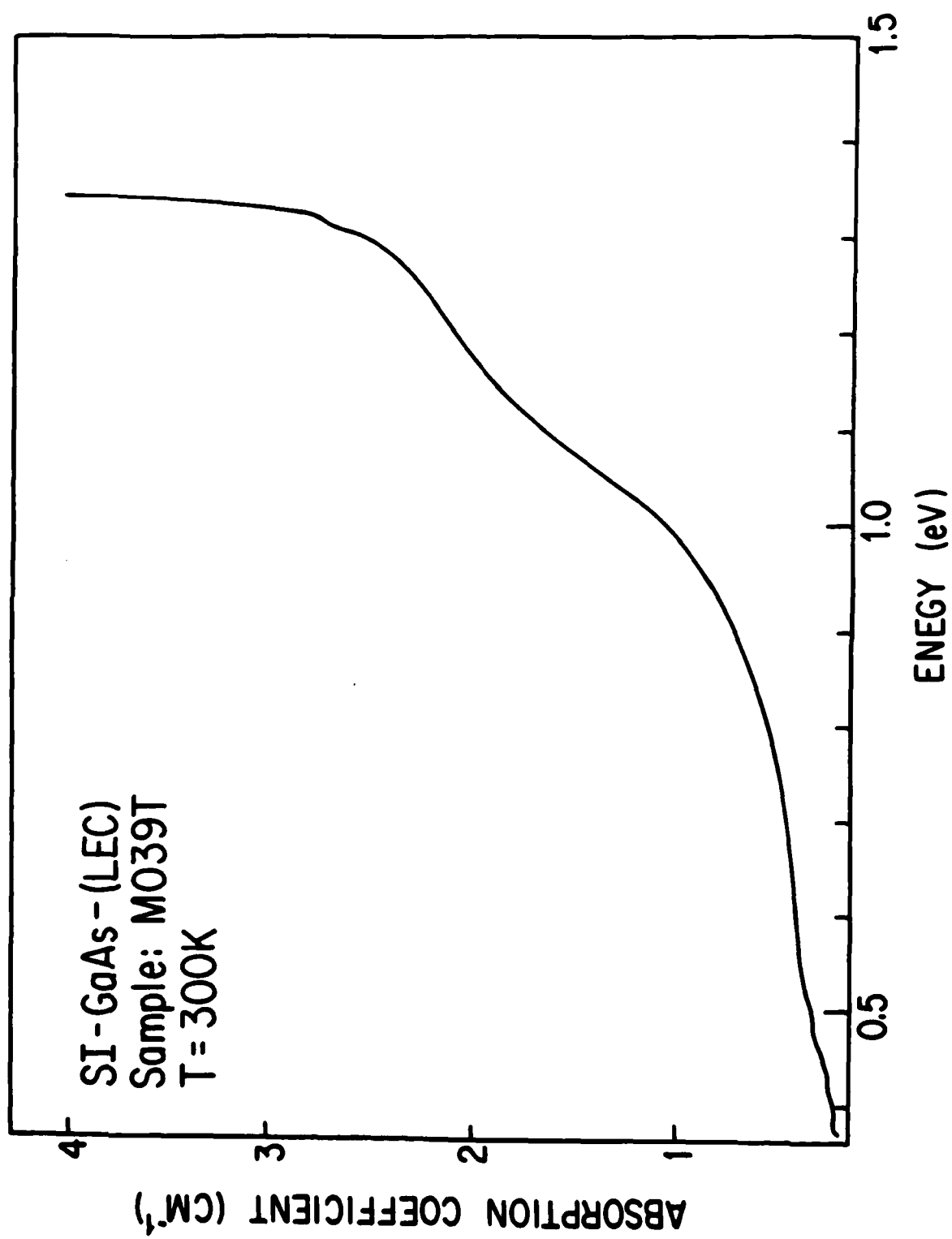

Fig. 2

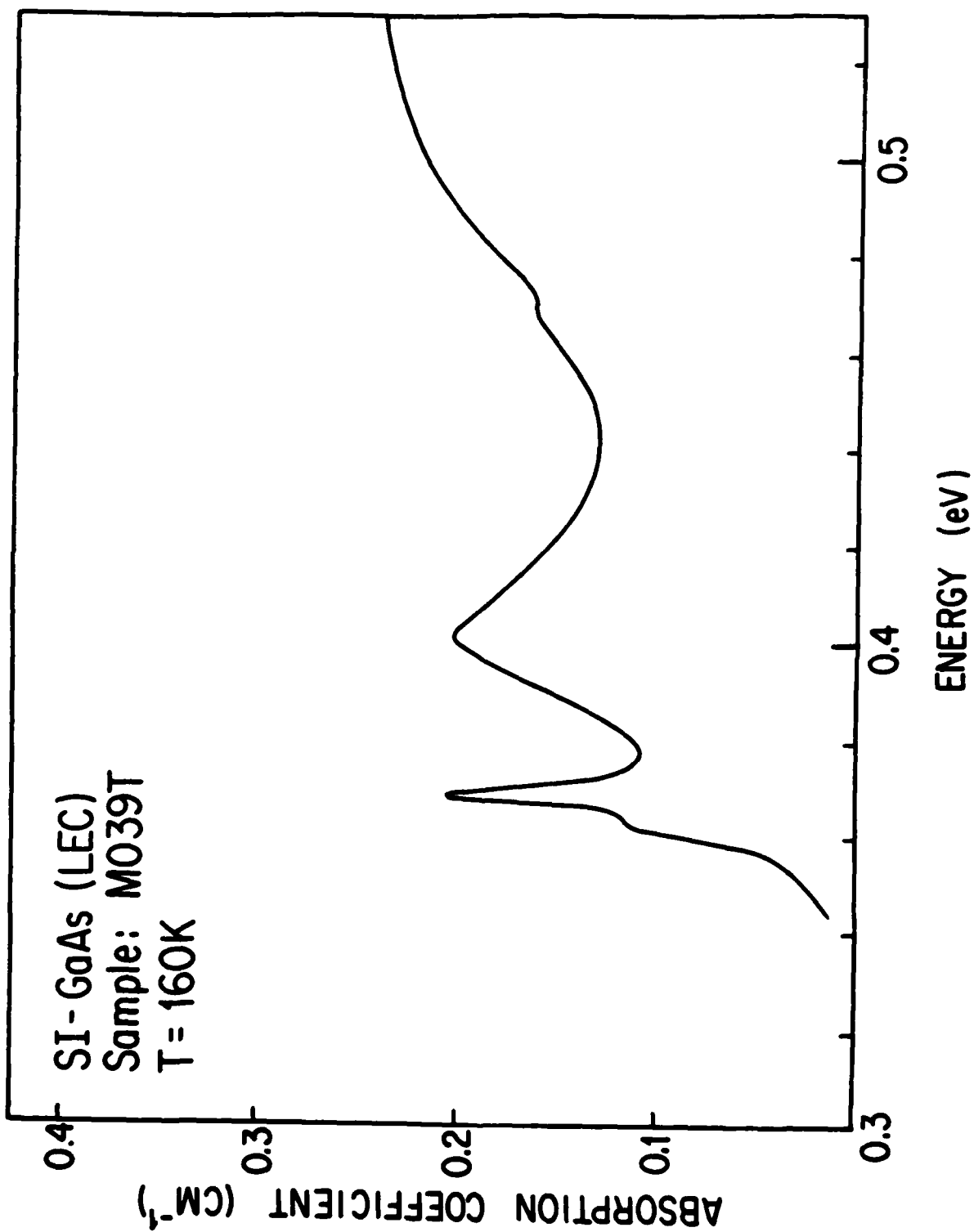

Fig. 3

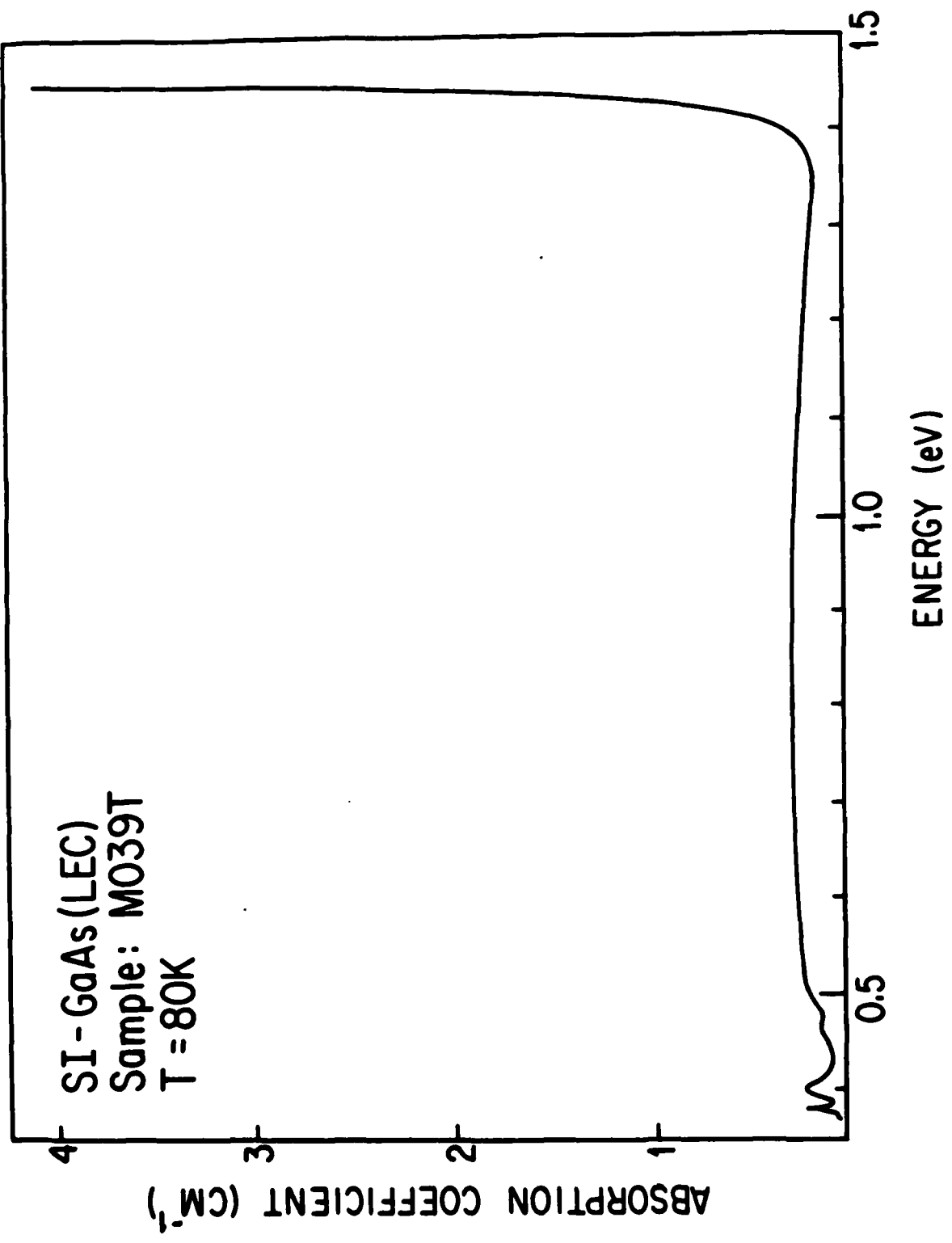

Fig. 4

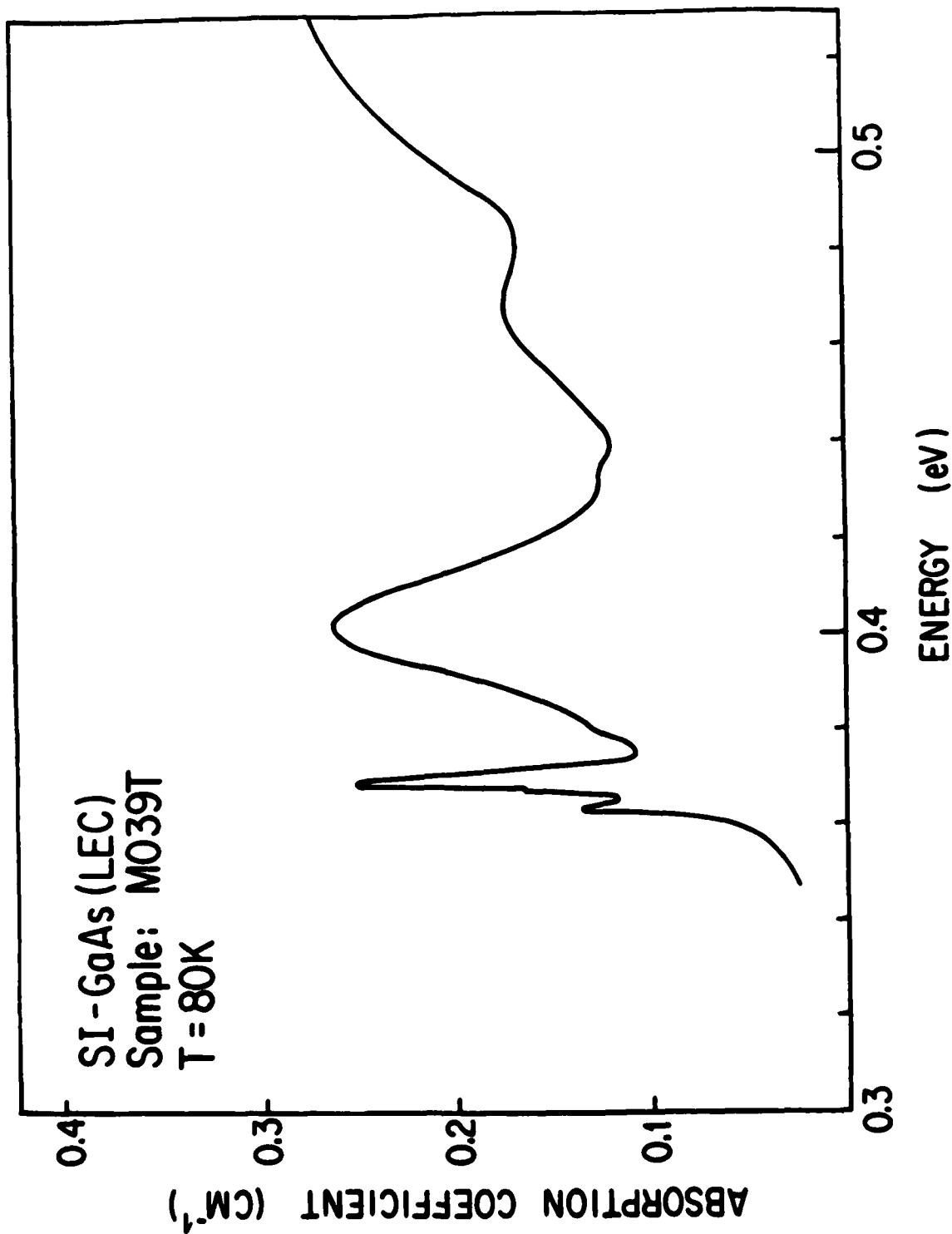

Fig. 5

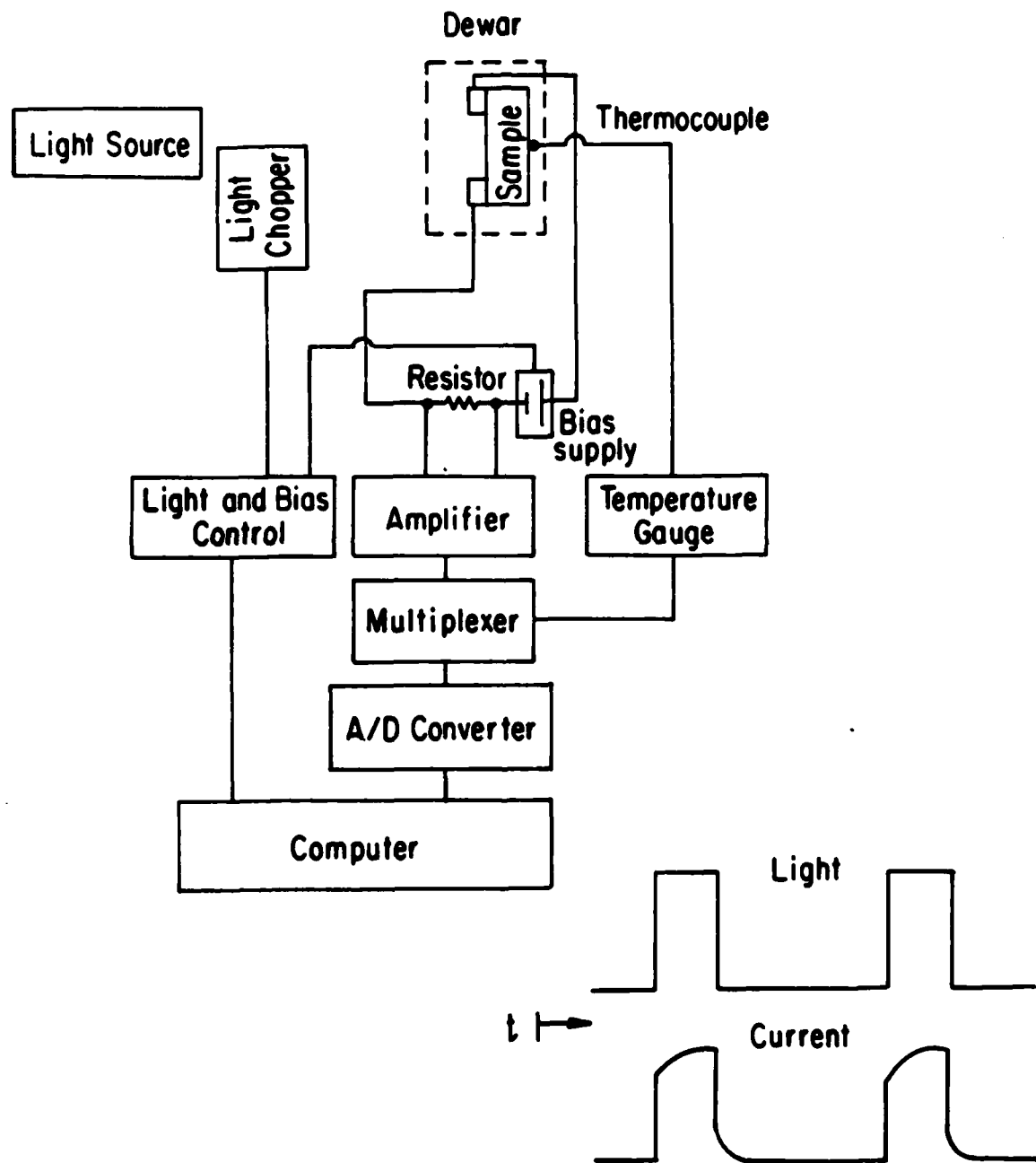

Fig. 6

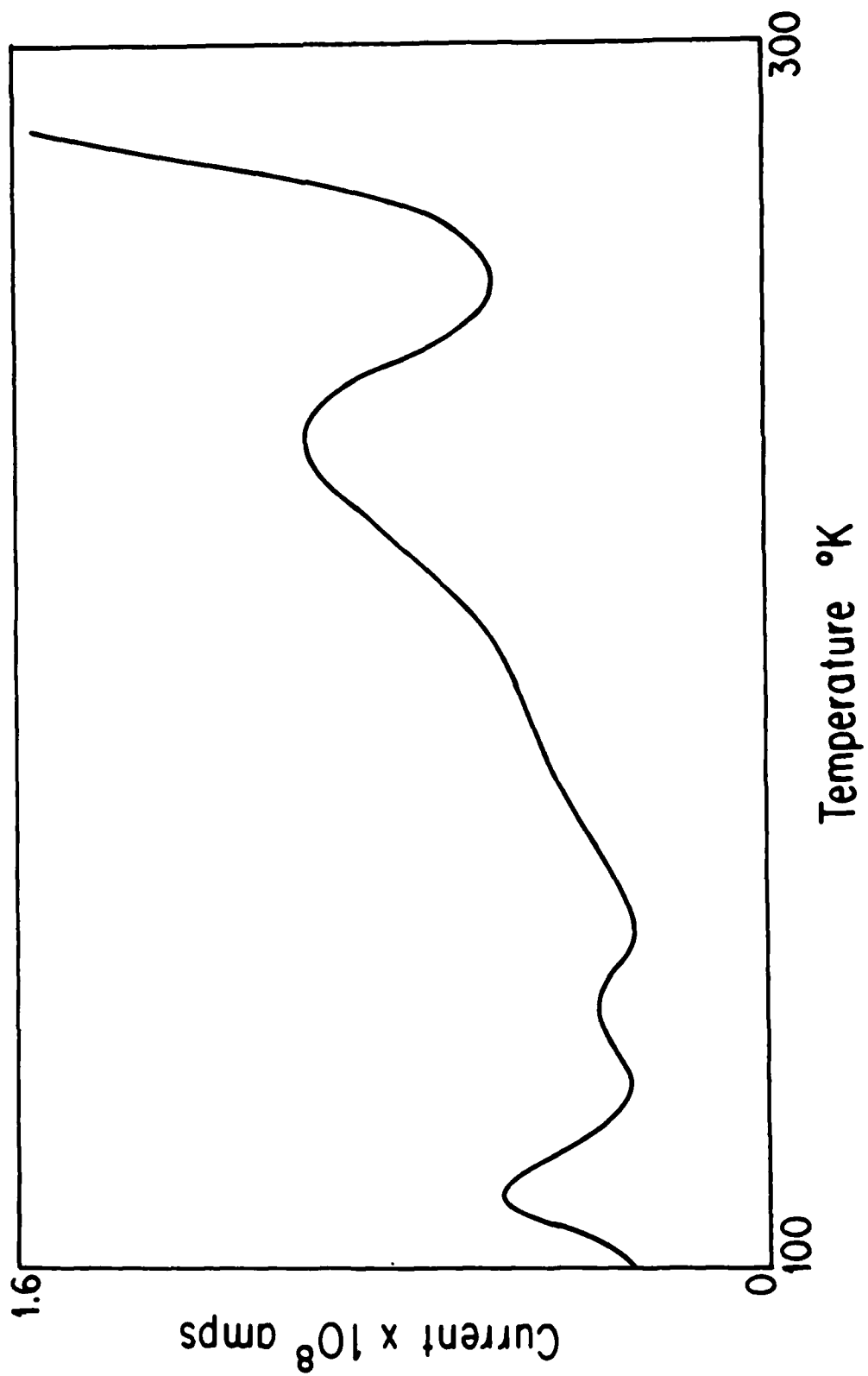

Fig. 7

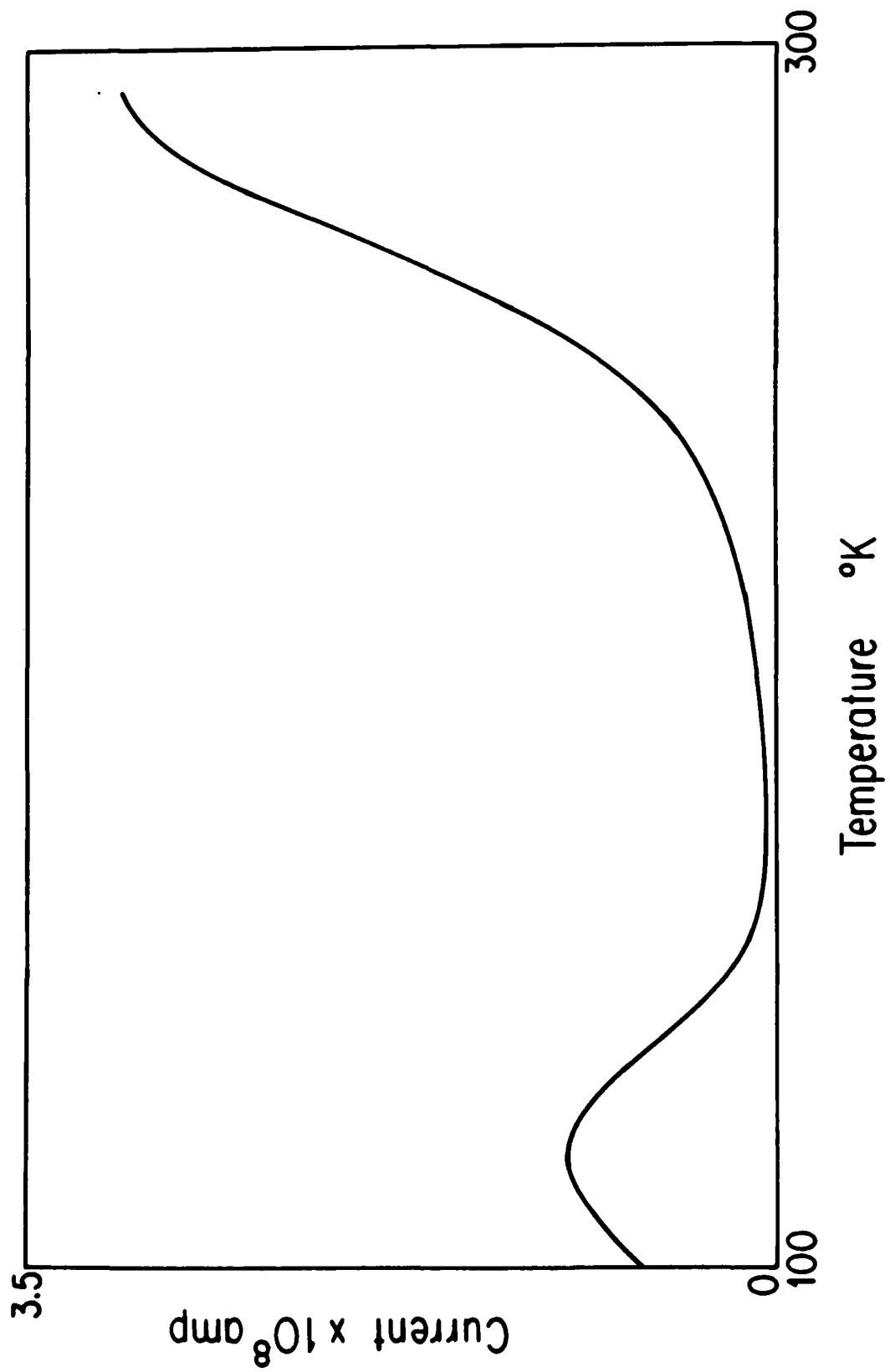

Fig. 8

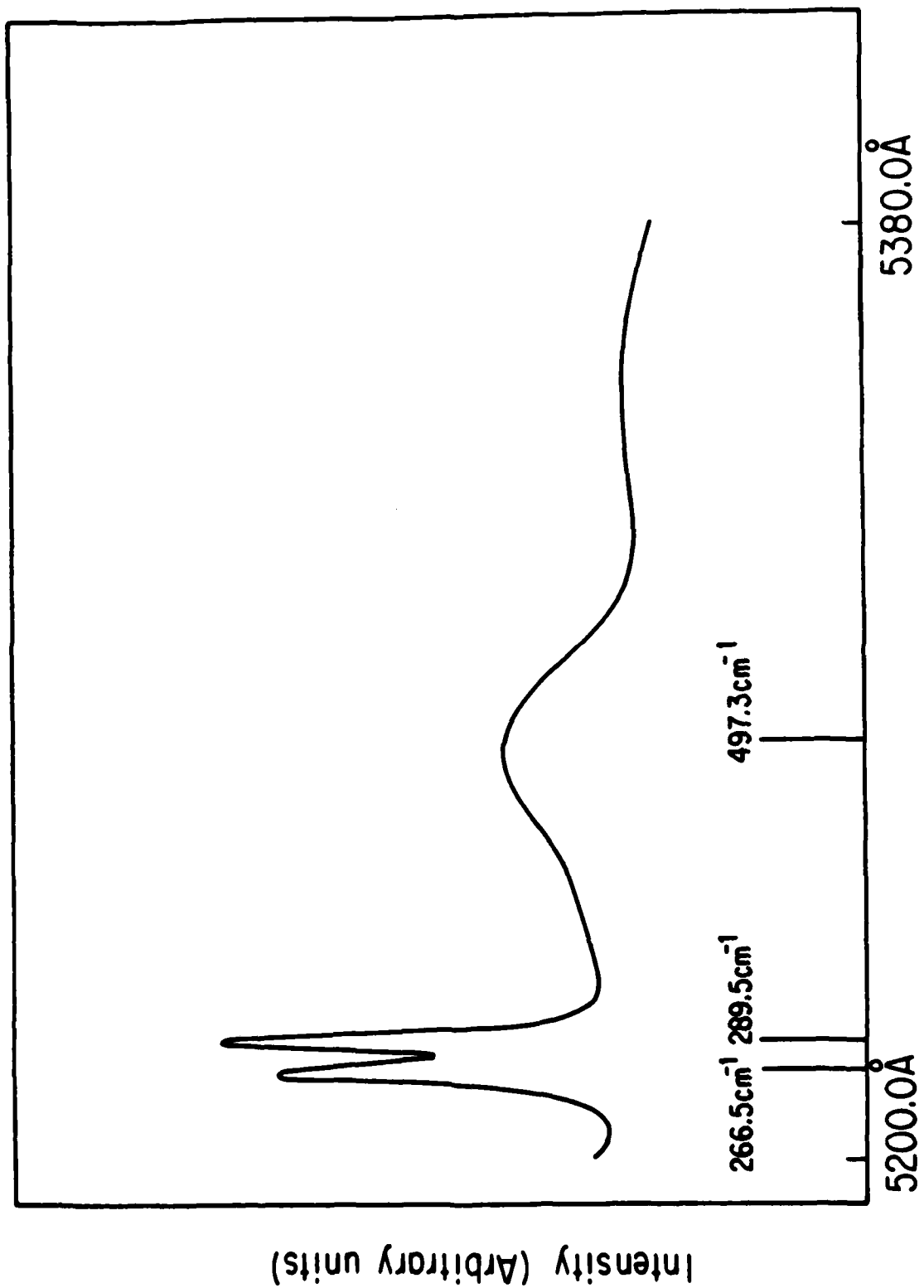

Fig. 9

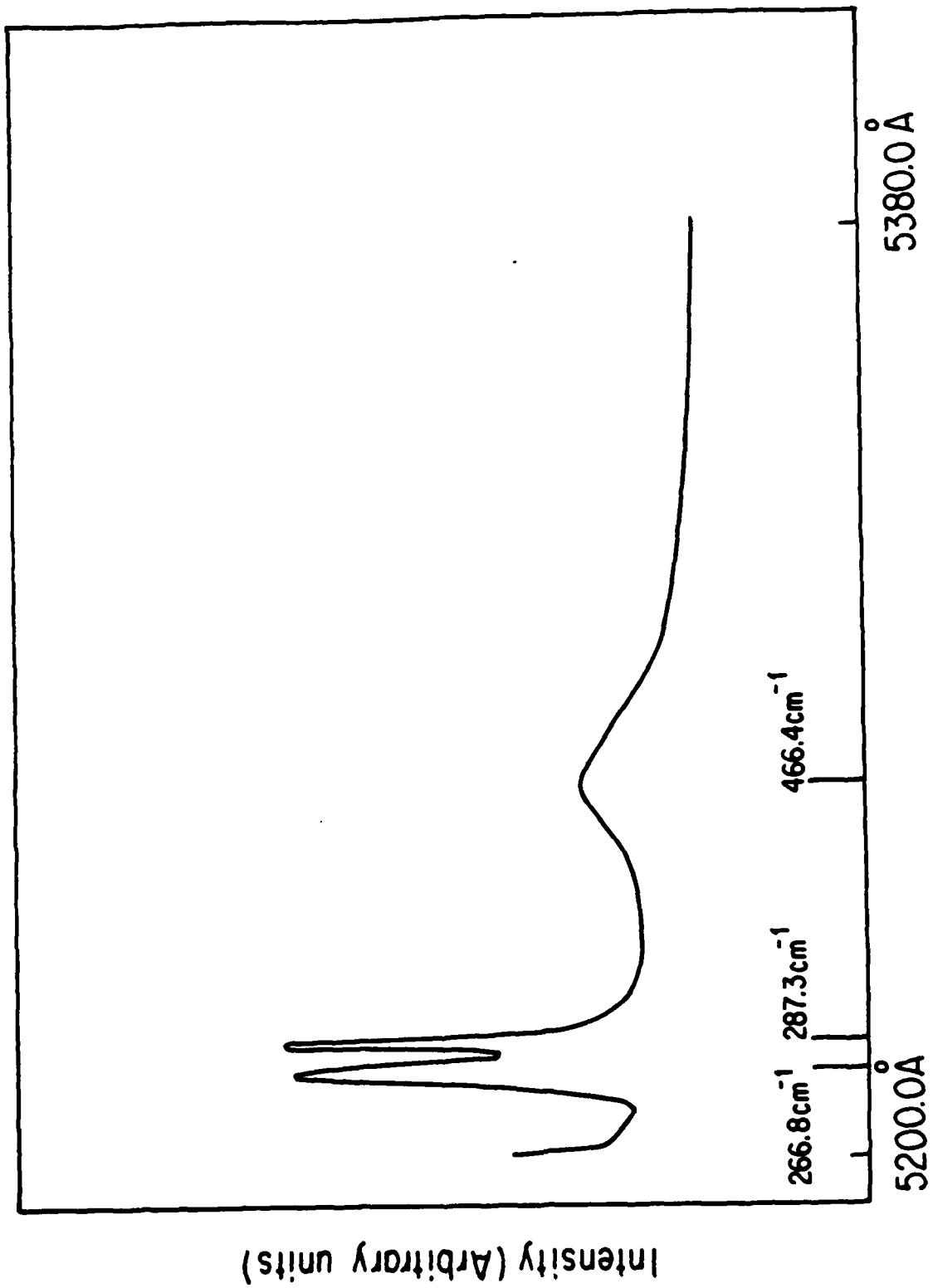

Fig. 10

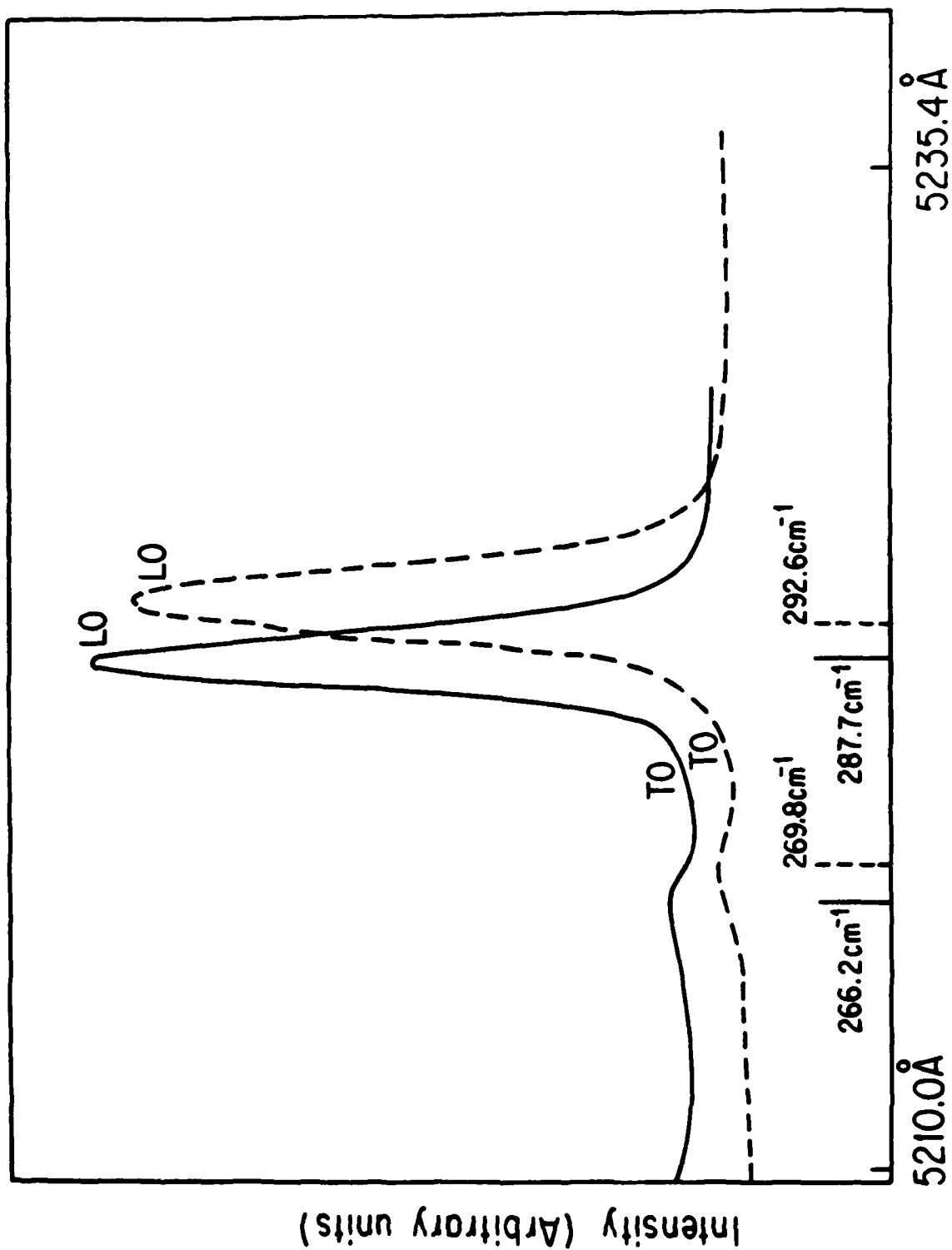

Fig. 11

VII. SCIENTIFIC INTERACTIONS

Although the UCLA program is self-contained, close communication was developed with materials synthesis groups at the Hughes Research Laboratory, Watkins and Johnson, the Air Force Avionics Laboratory, and other laboratories involved in the synthesis of layered semiconductors. These interactions included exchange of samples and technical discussions of the experimental and theoretical results of the UCLA group. Seminars were given at University of California at Irvine and the University of Southern California on "Deep Level Derivation Spectroscopy of Semiconductors."

FILMED