

AD-A144 081

NATIONAL PROGRAM FOR INSPECTION OF NON-FEDERAL DAMS
CURTIS POND DAM (CT 0..(U) CORPS OF ENGINEERS WALTHAM
MA NEW ENGLAND DIV MAR 81

1/2

UNCLASSIFIED

F/G 13/13

NL

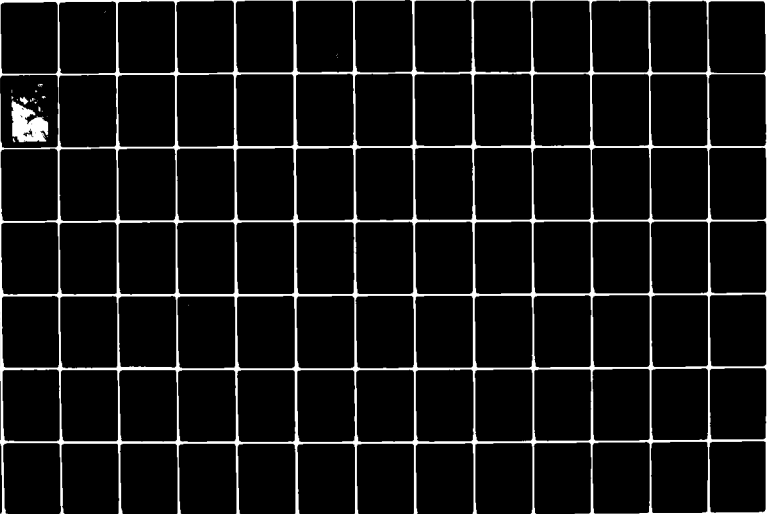

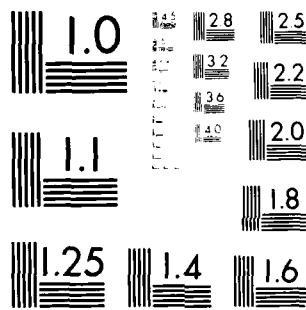

MICROCOPY RESOLUTION TEST CHART
NATIONAL BUREAU OF STANDARDS-1963-A

AD-A144 081

CONNECTICUT COASTAL BASIN
NEWTOWN, CONNECTICUT

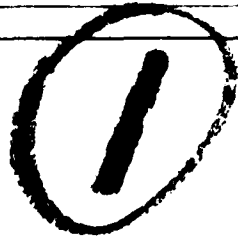

CURTIS POND DAM
CT 00312

PHASE I INSPECTION REPORT
NATIONAL DAM INSPECTION PROGRAM



DEPARTMENT OF THE ARMY
NEW ENGLAND DIVISION, CORPS OF ENGINEERS
WALTHAM, MASS. 02154

DTIC FILE COPY

MARCH 1981

DTIC
ELECT
S AUG 13 1981

DISTRIBUTION STATEMENT A
Approved for public release
Distribution Unlimited

D

UNCLASSIFIED

SECURITY CLASSIFICATION OF THIS PAGE (When Data Entered)

REPORT DOCUMENTATION PAGE		READ INSTRUCTIONS BEFORE COMPLETING FORM
1. REPORT NUMBER CT 00312	2. GOVT ACCESSION NO. <i>ADP 00312</i>	3. RECIPIENT'S CATALOG NUMBER
4. TITLE (and Subtitle) Curtis Pond Dam NATIONAL PROGRAM FOR INSPECTION OF NON-FEDERAL DAMS		5. TYPE OF REPORT & PERIOD COVERED INSPECTION REPORT
		6. PERFORMING ORG. REPORT NUMBER
7. AUTHOR(s) U.S. ARMY CORPS OF ENGINEERS NEW ENGLAND DIVISION		8. CONTRACT OR GRANT NUMBER(s)
9. PERFORMING ORGANIZATION NAME AND ADDRESS		10. PROGRAM ELEMENT, PROJECT, TASK AREA & WORK UNIT NUMBERS
11. CONTROLLING OFFICE NAME AND ADDRESS DEPT. OF THE ARMY, CORPS OF ENGINEERS NEW ENGLAND DIVISION, NEDED 424 TRAPELO ROAD, WALTHAM, MA. 02254		12. REPORT DATE March 1981
		13. NUMBER OF PAGES 70
14. MONITORING AGENCY NAME & ADDRESS (if different from Controlling Office)		15. SECURITY CLASS. (of this report) UNCLASSIFIED
		15a. DECLASSIFICATION/DOWNGRADING SCHEDULE
16. DISTRIBUTION STATEMENT (of this Report) APPROVAL FOR PUBLIC RELEASE: DISTRIBUTION UNLIMITED		
17. DISTRIBUTION STATEMENT (of the abstract entered in Block 20, if different from Report)		
18. SUPPLEMENTARY NOTES Cover program reads: Phase I Inspection Report, National Dam Inspection Program; however, the official title of the program is: National Program for Inspection of Non-Federal Dams; use cover date for date of report.		
19. KEY WORDS (Continue on reverse side if necessary and identify by block number) DAMS, INSPECTION, DAM SAFETY, Connecticut Coastal Basin Newtown, Connecticut		
20. ABSTRACT (Continue on reverse side if necessary and identify by block number) The Curtis Pond Dam is 235 feet long and consists of a 90-foot-long, 14-foot-high earth embankment extending from the right abutment, a 25-foot-long, 10-foot-high concrete broad-crested spillway weir, and a 120-foot-long, 14-foot-high embankment span between the spillway and the left abutment. Visual inspection indicated that the dam is in poor condition. It is considered to be small in size with a high hazard classification.		



DEPARTMENT OF THE ARMY
NEW ENGLAND DIVISION, CORPS OF ENGINEERS
424 TRAPELO ROAD
WALTHAM, MASSACHUSETTS 02254

REPLY TO
ATTENTION OF:

JUL 16 1981

NEDED

Honorable William A. O'Neill
Governor of the State of Connecticut
State Capitol
Hartford, Connecticut 06115

Dear Governor O'Neill:

Inclosed is a copy of the Curtis Pond Dam (CT-00312) Phase I Inspection Report, prepared under the National Program for Inspection of Non-Federal Dams. The report is based upon a visual inspection, a review of past performance, and a preliminary hydrological analysis.

The preliminary hydrologic analysis indicated that the spillway capacity for the Curtis Pond Dam would likely be exceeded by floods greater than 18 percent of the Probable Maximum Flood (PMF). Our screening criteria specifies that a dam classified as high hazard with a spillway capacity insufficient to discharge fifty percent of the PMF be judged as having a seriously inadequate spillway. As a result, this dam is assessed as unsafe, non-emergency, until more detailed studies prove otherwise or corrective measures are completed.

The term "unsafe" applied to a dam because of an inadequate spillway does not indicate the same degree of emergency as that term would if applied because of structural deficiency. It does indicate, however, that a severe storm may cause overtopping and possible failure of the dam, with significant damage and potential loss of life downstream.

We recommend that within twelve months from the date of this report the owner of the dam engage the services of a qualified registered engineer to determine further the potential of overtopping the dam and the need for and the means to increase project discharge capacity. Based on this determination, appropriate remedial mitigating measures should be designed and completed within 24 months of this date of notification. In the interim a detailed emergency operation plan and warning system should be promptly developed and round-the-clock surveillance should be provided during periods of heavy precipitation or high project discharge.

NEDED

Honorable William A. O'Neill

I approve the report and support the findings and recommendations described in Section 7, with qualifications as noted above. I request that you keep me informed of the actions taken to implement these recommendations since this follow-up is an important part of the program.

Copies of this report have been forwarded to the Department of Environmental Protection and to the owner, Curtis and Sons, Inc., Route 34, Sandy Hook, Connecticut 06482. Copies will be available to the public in thirty days.

I wish to thank you and the Department of Environmental Protection for your cooperation in this program.

Sincerely,

A handwritten signature in cursive script, appearing to read "C. E. Edgar, III".

C. E. EDGAR, III
Colonel, Corps of Engineers
Commander and Division Engineer

Accession For	
NTIS GRA&I	<input checked="" type="checkbox"/>
DTIC TAB	<input type="checkbox"/>
Unannounced	<input type="checkbox"/>
Justification	
By _____	
Distribution/	
Availability Codes	
Dist	Avail and/or Special
A/1	

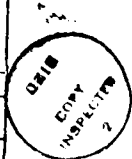

CURTIS POND DAM

CT 00312

CONNECTICUT COASTAL BASIN

NEWTOWN, CONNECTICUT

PHASE I INSPECTION REPORT
NATIONAL DAM INSPECTION PROGRAM

S DTIC ELECTE **D**
AUG 13 1984
D

DISTRIBUTION STATEMENT A
Approved for public release;
Distribution Unlimited

NATIONAL DAM INSPECTION PROGRAM

PHASE I INSPECTION REPORT

Identification No.: CT 00312
Name of Dam: Curtis Pond Dam
Town: Newtown
County and State: Fairfield, Connecticut
Stream: Curtis Pond Brook
Date of Inspection: December 11, 1980

BRIEF ASSESSMENT

The Curtis Pond Dam was originally constructed in 1856 to provide water for hydromechanical equipment in a nearby factory. The dam was partially breached during the flood of 1955 and reconstructed in 1956. Currently, the structure is used to create an impoundment to supply water to the fire protection equipment of the factory owned by S. Curtis and Sons, Inc. The entire structure is 235 feet long and consists of a 90-foot-long, 14-foot-high earth embankment extending from the right abutment, a 25-foot-long, 10-foot-high concrete broad-crested spillway weir, and a 120-foot-long, 14-foot-high embankment span between the spillway and the left abutment. The top of the embankment is approximately 14 feet wide and is 4 feet above the spillway crest elevation of 327 NGVD. (Note: All elevations are referenced to the National Geodetic Vertical Datum (NGVD).)

The outlet facilities consist of a 24-inch gated conduit at the base of the concrete spillway and an 18-inch ungated conduit in the left embankment. The 18-inch conduit leads to a narrow 975-foot-long fire canal, which provides water for the fire protection equipment at S. Curtis and Sons, Inc., via two pump houses located near the end of the canal. A concrete waste weir, located approximately 7 feet from the pump house intakes, diverts flow from the fire canal into an earth-lined channel that discharges into Curtis Pond Brook. Flow over the waste weir

only occurs when the water surface within the fire canal rises above elevation 327.4.

Visual inspection of the dam indicated that the dam is in poor condition. The inspection revealed considerable spalling and efflorescence of the spillway training walls, an inoperable low-level outlet, heavy vegetation on the dam, and evidence of seepage along the toe of the embankments.

In accordance with the Corps of Engineers' Recommended Guidelines for Safety Inspection of Dams, the top of dam storage capacity (80 ac-ft) and the height of the dam (14 feet), the project is considered to be small in size. In addition, the dam has been assigned a HIGH hazard classification as a result of the potential for the loss of more than a few lives due to a breach of the dam. Consequently, the test flood will be equivalent to one-half the Probable Maximum Flood (1/2 PMF). The resulting inflow to the pond is 1,087 cubic feet per second per square mile (cfs/sq. mi.) or 1,805 cubic feet per second (cfs). The test flood outflow is approximately 1,670 cfs; and the capacity of the spillway, with the water surface at the top of the dam, is 620 cfs or 37 percent of the routed test flood outflow. Therefore, the dam will be overtopped by about 1.2 feet.

Reynold A. Hokenson, P.E.
Reynold A. Hokenson, P.E.
Project Manager
International Engineering Company, Inc.

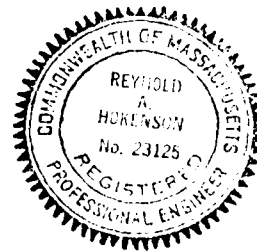

This Phase I Inspection Report on Curtis Pond Dam has been reviewed by the undersigned Review Board members. In our opinion, the reported findings, conclusions, and recommendations are consistent with the Recommended Guidelines for Safety Inspection of Dams, and with good engineering judgement and practice, and is hereby submitted for approval.



ARAMAST MAHTESIAN, MEMBER
Geotechnical Engineering Branch
Engineering Division

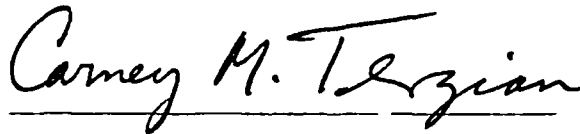

CARNEY M. TERZIAN, MEMBER
Design Branch
Engineering Division



JOSEPH W. FINEGAN, JR., CHAIRMAN
Water Control Branch
Engineering Division

APPROVAL RECOMMENDED:

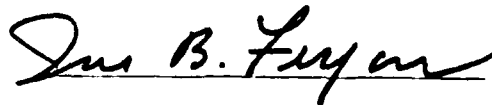

JOE B. FRYAR
Chief, Engineering Division

PREFACE

This report is prepared under guidance contained in the Recommended Guidelines for Safety Inspection of Dams, for Phase I Investigations. Copies of these guidelines may be obtained from the Office of Chief of Engineers, Washington, D.C. 20314. The purpose of a Phase I Investigation is to identify expeditiously those dams which may pose hazards to human life or property. The assessment of the general condition of the dam is based upon available data and visual inspections. Detailed investigation, and analyses involving topographic mapping, subsurface investigations, testing, and detailed computational evaluations are beyond the scope of a Phase I investigation; however, the investigation is intended to identify any need for such studies.

In reviewing this report, it should be realized that the reported condition of the dam is based on observations of field conditions at the time of inspection along with data available to the inspection team. In cases where the reservoir was lowered or drained prior to inspection, such action, while improving the stability and safety of the dam, removes the normal load on the structure and may obscure certain conditions which might otherwise be detectable if inspected under the normal operating environment of the structure.

It is important to note that the condition of a dam depends on numerous and constantly changing internal and external conditions, and is evolutionary in nature. It would be incorrect to assume that the present condition of the dam will continue to represent the condition of the dam at some point in the future. Only through continued care and inspection can there be any chance that unsafe conditions be detected.

Phase I inspections are not intended to provide detailed hydrologic and hydraulic analyses. In accordance with the established Guidelines, the Spillway Test flood is based on the estimated "Probable Maximum Flood" for the region (greatest reasonably possible storm runoff), or fractions thereof. Because of the magnitude and rarity of such a storm

event, a finding that a spillway will not pass the test flood should not be interpreted as necessarily posing a highly inadequate condition. The test flood provides a measure of relative spillway capacity and serves as an aid in determining the need for more detailed hydrologic and hydraulic studies, considering the size of the dam, its general condition, and the downstream damage potential.

The Phase I Investigation does not include an assessment of the need for fences, gates, no-trespassing signs, repairs to existing fences and railings and other items which may be needed to minimize trespass and provide greater security for the facility and safety to the public. An evaluation of the project for compliance with OSHA rules and regulations is also excluded.

TABLE OF CONTENTS

<u>Section</u>	<u>Page</u>
Letter of Transmittal	
Brief Assessment	
Review Board Page	
Preface	i
Table of Contents	iii
Overview Photo	vi
Location Map	vii

REPORT

1. PROJECT INFORMATION	
1.1 General	i
a. Authority	1-1
b. Purpose of Inspection Program	1-1
c. Scope of Inspection Program	1-2
1.2 Description of Project	1-2
a. Location	1-2
b. Description of Dam and Appurtenances	1-2
c. Size Classification	1-4
d. Hazard Classification	1-4
e. Ownership	1-4
f. Operator	1-4
g. Purpose of Dam	1-4
h. Design and Construction History	1-5
i. Normal Operational Procedures	1-5
1.3 Pertinent Data	1-6
2. ENGINEERING DATA	2-1
2.1 Design Data	2-1
2.2 Construction Data	2-1
2.3 Operation Data	2-1
2.4 Evaluation of Data	2-2

<u>Section</u>	<u>Page</u>
3. VISUAL INSPECTION	3-1
3.1 Findings	3-1
a. General	3-1
b. Dam	3-1
c. Appurtenant Structures	3-2
d. Reservoir Area	3-3
e. Downstream Channel	3-3
3.2 Evaluation	3-3
4. OPERATIONAL AND MAINTENANCE PROCEDURES	4-1
4.1 Operational Procedures	4-1
a. General	4-1
b. Description of any Warning System in Effect	4-1
4.2 Maintenance Procedures	4-1
a. General	4-1
b. Operating Facilities	4-1
4.3 Evaluation	4-1
5. EVALUATION OF HYDRAULIC/HYDROLOGIC FEATURES	5-1
5.1 General	5-1
5.2 Design Data	5-1
5.3 Experience Data	5-1
5.4 Test Flood Analysis	5-2
5.5 Dam Failure Analysis	5-2
6. EVALUATION OF STRUCTURAL STABILITY	6-1
6.1 Visual Observation	6-1
6.2 Design and Construction Data	6-1
6.3 Post-Construction Changes	6-1
6.4 Seismic Stability	6-1

<u>Section</u>	<u>Page</u>
7. ASSESSMENT, RECOMMENDATIONS AND REMEDIAL MEASURES	7-1
7.1 Dam Assessment	7-1
a. Condition	7-1
b. Adequacy of Information	7-1
c. Urgency	7-1
7.2 Recommendations	7-1
7.3 Remedial Measures	7-2
a. Operation and Maintenance Procedures	7-2
7.4 Alternatives	7-3
APPENDIX A - INSPECTION CHECKLIST	A-1
APPENDIX B - ENGINEERING DATA	B-1
APPENDIX C - PHOTOGRAPHS	C-1
APPENDIX D - HYDROLOGIC AND HYDRAULIC COMPUTATIONS	D-1
APPENDIX E - INFORMATION AS CONTAINED IN THE NATIONAL INVENTORY OF DAMS	E-1



OVERVIEW PHOTO-CURTIS POND DAM
JANUARY 19, 1981

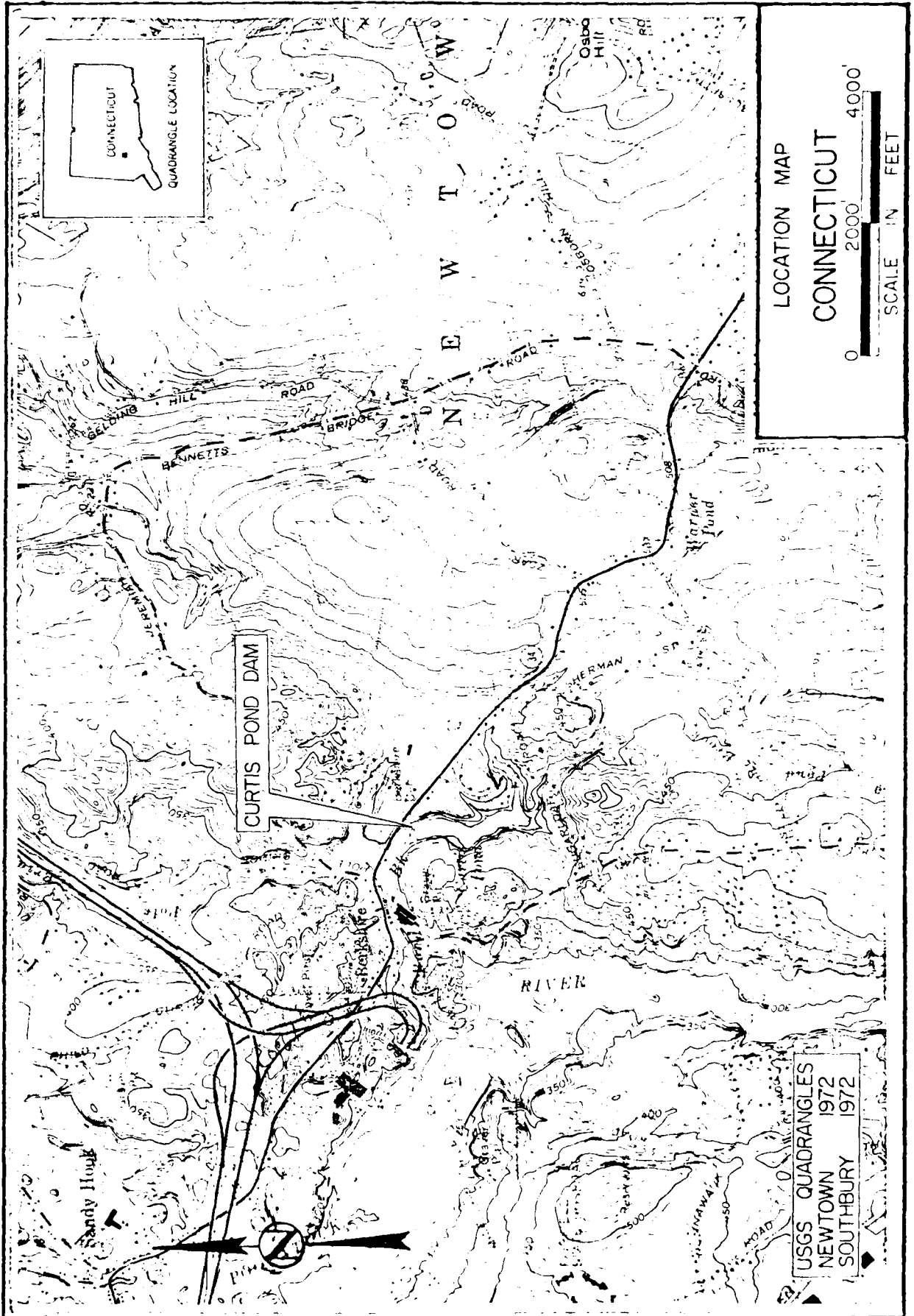

NATIONAL DAM INSPECTION PROGRAM

PHASE I INSPECTION REPORT

CURTIS POND DAM

SECTION 1: PROJECT INFORMATION

1.1 GENERAL

a. Authority -- Public Law 92-367, August 8, 1972, authorized the Secretary of the Army, through the Corps of Engineers, to initiate a National Program of Dam Inspection. The New England Division of the Corps of Engineers has been assigned the responsibility of supervising the inspection of dams within the New England region. International Engineering Company, Inc., has been retained by the Corps' New England Division to inspect and report on selected dams in the State of Connecticut. Authorization and notice to proceed were issued to International Engineering Company, Inc., in a letter dated November 5, 1980, from William E. Hodgson, Jr., Colonel, Corps of Engineers. Contract No. DACW33-81-C-0015 has been designated by the Corps for this work.

b. Purpose of Inspection Program -- The purposes of the program are to:

- (1) Perform technical inspections and evaluations of non-Federal dams to identify conditions requiring correction in a timely manner by non-Federal interests.
- (2) Encourage and prepare the States to quickly initiate effective dam inspection programs for non-Federal dams.
- (3) Update, verify, and complete the National Inventory of Dams.

c. Scope of Inspection Program - The scope of this Phase I Inspection Report includes:

- (1) Gathering, reviewing, and presenting all available data as can be obtained from the owners, previous owners, the state, and other associated parties.
- (2) A field inspection of the facility detailing the visual condition of the dam, embankments, and appurtenant structures.
- (3) Computations concerning the hydraulics and hydrology of the facility and its relationship to the calculated flood through the existing spillway.
- (4) An assessment of the condition of the facility and corrective measures required.

It should be noted that this report does not pass judgement on the safety or stability of the dam other than on a visual basis. The purpose of the inspection is to identify those features of the dam which need corrective action and/or further study.

1.2 DESCRIPTION OF PROJECT

a. Location - The dam is located on Curtis Pond Brook in the Town of Newtown, Fairfield County, Connecticut, approximately 3,900 feet upstream from the confluence with the Pootatuck River. The location of the dam is defined by the coordinates latitude $N41^{\circ}24.4'$ and longitude $W73^{\circ}15.5'$ on the Newtown, Connecticut, USGS Quadrangle Map.

b. Description of Dam and Appurtenances - The facility consists of two earthfill embankments, a concrete gravity spillway section, and a canal, which provides water for fire protection equipment at the adjacent factory (see Appendix B, Sheet B-1). The left and right embankments of the dam are roughly 120 feet and 90 feet in length, respectively. The

embankments are 14 feet wide at the top and about 14 feet in height. The upstream and downstream faces of the dam are inclined at approximately 5:1 slopes.

The overflow section is a 25-foot-long concrete broad-crested spillway with two 2-foot-wide concrete training walls, forming the spillway abutments, and a short riprapped apron. The spillway crest elevation is 327 NGVD or 4 feet below the top of the dam. A seepage barrier composed of steel sheeting was driven to a depth of 9 feet into the spillway's underlying foundation material approximately 2 feet from the vertical upstream face of the spillway and extending the entire length of this overflow section.

The outlet works consist of a 24-inch gated conduit passing through the concrete spillway and an 18-inch ungated conduit in the left embankment. The 24-inch low-level outlet is located near the base of the spillway and adjacent to the right training wall (invert El. 317.0). A platform extends from the upstream portion of the right training wall to support a hand-operated control mechanism for the conduit sluice gate.

The 18-inch conduit, located near the left bank, is founded in a masonry structure that can be observed on the downstream slope of the dam. The conduit empties into a fire canal, which is 975 feet long, 12 feet wide at the top, and leads to two intake structures and a waste weir. The side slopes of the canal are formed by an earthen dike on the right and a natural slope, which extends almost the full length of the canal, on the left. The dike is approximately 6 feet wide at the crest and has a 1:1 downstream slope. The 12-foot-long waste weir (crest elevation 327.4) is located in the earth dike near the end of the canal. Discharge from the weir flows through an earth-lined channel and is returned to Curtis Pond Brook. Two intakes, located 7 feet from the waste weir, direct water to the fire protection system via two 8-inch feedlines. Water is drawn from the canal by the equipment in the adjacent pump houses and piped to the sprinkler system in the S. Curtis and Sons, Inc., factory (Appendix B, Sheet B-1).

c. Size Classification - (SMALL) - The classification for size is based on the height of the dam above the natural streambed or the maximum storage potential, which is considered to be the storage resulting from the water surface elevation within the impoundment being equal to the elevation of the top of the dam. The size of the dam is then determined by either storage or height depending on which criteria yields the larger size category. Curtis Pond Dam has a maximum potential storage capacity of 80 ac-ft, which is within the established limits for the small size category (50 ac-ft to 1,000 ac-ft) while the height of the dam (14 feet) is below the limits for the small size category (25 feet to 50 feet). Consequently, the dam is considered to be SMALL in size.

d. Hazard Classification - (HIGH) - The hazard classification is based on the estimated loss of life and the anticipated property damage due to a dam breach when the water surface, within the impoundment, is at the top of the dam. The failure of Curtis Pond Dam would cause the water level within the first 500-foot-long reach of Curtis Pond Brook, downstream of the dam, to rise from 4.0 feet at a prefailure outflow of 620 cfs to 14.0 feet after the failure. Due to the variation in the downstream channels cross-sectional features, the water level within the second 500-foot-long reach will rise from 4.0 feet at a prefailure outflow of 620 cfs to 14.7 feet after the failure. As a result, the dam failure will flood the first floor of one home to a depth of 6 feet and three homes to depth of 4 to 5 feet. The S. Curtis and Sons, Inc. factory and one additional home will experience less than a foot of flooding. No prefailure flooding is anticipated. The dam failure will damage 5 homes, 1 factory, and the bridge supporting the S. Curtis and Sons, Inc., driveway and could potentially cause the loss of more than a few lives. Therefore, the dam has been classified as having a HIGH hazard potential.

e. Ownership - S. Curtis and Sons, Inc.
Route 34
Sandy Hook, Connecticut 06482
(203) 426-5861

f. Operator — S. Curtis and Sons, Inc.
George Blake
Maintenance Foreman

g. Purpose of Dam — The dam was originally used to supply water to the hydromechanical equipment in a nearby factory. This equipment was later replaced with hydroelectric generation equipment, which provided electricity to the factory until the early 1950's. Currently, the facility provides water for the fire protection system in the adjacent factory owned by S. Curtis and Sons, Inc. There is no recreational activity at the site since it is privately owned and trespassing is discouraged.

h. Design and Construction History — The original dam, constructed in 1856, created an impoundment that provided water for the hydromechanical equipment in a factory located on the site currently occupied by S. Curtis and Sons, Inc. This equipment was later removed and replaced by hydroelectric generation equipment. Originally, the existing canal provided water directly to the factory, thus bypassing a portion of Curtis Pond Brook. Until the early 1950's, a 33-foot undershot wheel provided 50 percent of the electrical power for the factory. Once the demand for power exceeded the capacity of the undershot wheel, alternate sources of power were obtained and the generation equipment was removed. The Curtis Pond facility was then adapted for fire protection.

In October 1955, the dam was partially breached, two or three downstream bridges were destroyed, and some other property damage was caused. Shortly after the incident, Austin Warner Consulting Engineers, West Cheshire, Connecticut, were retained by S. Curtis and Sons, Inc., to design a new spillway section for the dam. A concrete gravity structure was finally constructed in 1956 by a local contractor, John Stefanco.

i. Normal Operational Procedures — The water level in the pond is maintained at the spillway crest (El. 327). It is no longer possible to operate the low-level outlet; therefore, the pond is never drained. The

fire protection equipment in the pump houses is activated automatically by the sprinkler system in the factory.

1.3 PERTINENT DATA

a. Drainage Area — The drainage area consists of 1.66 square miles (sq. mi.) of relatively undeveloped, rolling, wooded terrain with the exception of a quarry located approximately 500 feet east of the dam.

b. Discharge at Dam Site — Discharges from the site were intended to occur over the concrete spillway and through the low-level outlet and the fire canal.

- (1) When the water surface is at the top of the dam (El. 331), the 24-inch low-level outlet (invert El. 317) will pass 57 cfs.
- (2) The maximum known flood at the dam site overtopped and partially breached the dam in October 1955.
- (3) Ungated capacity of the spillway is 620 cfs at elevation 331.
- (4) Ungated spillway capacity at test flood elevation (332.2) is 920 cfs.
- (5) Gated spillway capacity at normal pool elevation — N/A.
- (6) Gated spillway capacity at test flood elevation — N/A.
- (7) Total spillway capacity at test flood elevation (332.2) is 920 cfs.
- (8) Total project discharge at top of dam (El. 331) is 620 cfs.
- (9) Total project discharge at test flood (El. 332.2) is 1,670 cfs.

c. Elevations (feet above NGVD)

(1) Streambed at toe of dam	317.0
(2) Bottom of cutoff	Unknown
(3) Maximum tailwater	Unknown
(4) Normal pool	327.0
(5) Flood-control pool	327.0
(6) Spillway crest	327.0
(7) Waste weir	327.4
(8) Design surcharge (original design)	330.0
(9) Top of dam	331.0
(10) Test flood surcharge	332.2

d. Reservoir (length in feet)

(1) Normal pool	1,400
(2) Flood-control pool	1,400
(3) Spillway crest pool	1,400
(4) Top of dam	1,700
(5) Test flood pool	1,800

e. Storage (acre-feet)

(1) Normal pool	32
(2) Flood-control pool	32
(3) Spillway crest pool	32
(4) Top of dam	80
(5) Test flood pool	85

f. Reservoir Surface (acres)

(1) Normal pool	7.87
(2) Flood-control pool	7.87
(3) Spillway crest	7.87
(4) Top of dam	12.8
(5) Test flood pool	13.9

g. Dam

(1) Type	Earthfill embankment
(2) Length	235 ft
(3) Height	14 ft
(4) Top Width	14 ft
(5) Side Slopes	5 H to 1 V upstream and downstream

- | | |
|---------------------|---------|
| (6) Zoning | Unknown |
| (7) Impervious Core | Unknown |
| (8) Cutoff | Unknown |
| (9) Grout Curtain | Unknown |
| (10) Other | None |

h. Diversion Canal - Fire Canal

- | | |
|---------------------------|---|
| (1) Type | Open channel |
| (2) Length | 975 feet |
| (3) Closure | N/A |
| (4) Access | N/A |
| (5) Regulating Facilities | Two 8-inch pipes and a
12-foot-long waste weir
at end of the canal. |

i. Spillway

- | | |
|---------------------|-----------------------------|
| (1) Type | Broad-crested concrete weir |
| (2) Length of weir | 25 ft |
| (3) Crest elevation | 327.0 |
| (4) Gates | None |
| (5) U/S Channel | Curtis Pond |
| (6) D/S Channel | Curtis Pond Brook |

j. Regulating Outlets - Low-level outlet drain in concrete spillway.

- | | |
|-----------------------|--|
| (1) Invert Elevation | 317 |
| (2) Size | 24-inch diameter |
| (3) Description | ACCMP |
| (4) Control Mechanism | Hand operated |
| (5) Other | 18-inch fire canal intake conduit on the left side of the dam. Invert elevation estimated to be 325.5. |

SECTION 2: ENGINEERING DATA

2.1 DESIGN DATA

No original design data was available. The available data consisted of two sets of drawings depicting the alternatives proposed by Austin Warner Consulting Engineers (1956) for the replacement of the breached spillway section at Curtis Pond Dam. Preliminary stability computations for each alternative and correspondence during the design period between the consultant, the State of Connecticut Water Resources Department, and the State Board for Dams, Dikes, and Reservoirs were obtained. The spillway crest elevation was assumed to correspond to the pond surface elevation shown on the USGS Quadrangle Map. All other key elevations were computed from the available drawings.

2.2 CONSTRUCTION DATA

No original construction data was available. The Certificate of Approval and the accompanying cover letter, signed by a representative of the State of Connecticut Board of Supervision of Dams, are the only documentation of the successful reconstruction of the dam available to date. The inspection date of the new structure was September 24, 1956. No information was available concerning difficulties encountered during the reconstruction of the dam.

2.3 OPERATION DATA

There are no provisions for monitoring the pond level or the condition of the dam. According to a representative from S. Curtis and Sons, Inc., the fire protection equipment and the fire canal are inspected semiannually by the company's insurer (Factory Mutual). These inspections may include a visual inspection of the fire canal's pond inlet, the canal itself, and the pumphouse intakes. In addition, the pumps are started and checked. A letter outlining the inspection findings and recommendations is then sent to S. Curtis and Sons, Inc. No formal operation records were available at the time of the inspection.

2.4 EVALUATION OF DATA

a. Availability — Data was provided by the owner and the State of Connecticut Water Resource Department. The owner made the site accessible for the inspection and provided a representative for consultation during the inspection.

b. Adequacy — The available engineering data was generally adequate for the assessment of the spillway capacity. However, there was no information concerning the embankment design and construction. As a result, this assessment of the dam was based on the visual inspection, performance history, hydraulic computations of spillway capacity, and approximate hydrologic judgements.

c. Validity — The field inspection indicated that the external features of the spillway section at Curtis Pond Dam coincide with those shown on the available plans.

SECTION 3: VISUAL INSPECTION

3.1 FINDINGS

a. General — The field inspection of Curtis Pond Dam was conducted on December 10, 1980. The general condition of the facility is poor and many areas requiring maintenance, monitoring, and repair were defined during the inspection. The pond level was approximately 327.1 NGVD; and there was flow over the spillway section, but no flow was observed in the fire canal.

b. Dam — The top of the dam has been overgrown with grass, brush, and trees ranging from 3 to 24 inches in diameter (Photos 1 and 2). The upstream slope varies as a result of root infiltration and erosion (Photos 2 and 3). Erosion of the embankments was most predominant in the vicinity of the spillway training walls. The voids caused by the displaced earthfill adjacent to the training walls on the upstream slope are approximately 3 feet wide and 2 feet deep and extend from near the upstream toe to the top of the dam. The remainder of the slope varied due to the growth of trees and localized erosion near the base of some of the larger trees. In addition, there were no indications of riprap slope protection beneath the heavy ground cover.

The downstream slope was also overgrown with brush and heavily wooded (Photo 2). Seepage was noted emanating from the right embankment approximately 25 feet from the spillway training wall at a rate of about 1 gallon per minute (gpm). As a result, an area adjacent to the toe of the dam about 45 feet long and 15 feet wide has become marshy. The area at the toe of the left embankment, from the spillway training wall to the canal dike and extending about 100 feet along the toe of the dike, was also marshy; however, there was no visible flow above the ground. The marshy areas at the toe of the embankments and the erosion on the upstream slope have been outlined on the Photo Location Plan (Appendix C).

c. Appurtenant Structures - The concrete spillway is in generally fair condition (Photos 2, 3, and 4). The spillway concrete was slightly eroded, thus exposing some aggregate. In addition, there was an accumulation of debris on the spillway crest and on the spillway apron. The riprap on the apron was displaced or missing in several areas and was overgrown with vegetation in places (Photo 4). The concrete training walls have deteriorated, exposing the horizontal reinforcing on top of the walls (Photo 2). The exposed wall surfaces showed signs of excessive efflorescence and spalling.

The low-level outlet is no longer operational, since the control mechanism and the platform that supported it have been destroyed (Photo 3). No flow was observed in the outlet during the inspection.

The fire canal and the containment dike are overgrown with vegetation. Trees ranging from 3 to 15 inches in diameter were noted on the dike and in the fire canal (Photos 5 and 6). The depth of the canal appears to have been significantly decreased due to an accumulation of debris in the canal bottom. At the time of the inspection, no flow was observable in the canal.

The top of the canal dike was uneven and varied in width along the entire length. Localized erosion was noted in several areas along the top, slopes, and toe of the dike. A wet, marshy area near the intersection of the toe of the dike and dam, extending approximately 100 feet from the dam, has apparently resulted from seepage through the embankments.

The masonry joints on the cut stone wall surrounding the 18-inch canal intake conduit have deteriorated (Photo 5). The inspection team was unable to locate the upstream entrance to the intake conduit due to the water level and the silt in the pond.

The concrete waste weir was generally sound, but some minor spalling was noted along the crest (Photo 7). The fire protection equipment, intakes, and trashracks appeared to be in relatively good condition.

d. Reservoir Area — The area surrounding the reservoir is largely wooded and undeveloped. The slopes near the dam are stable and do not show any visible signs of erosion.

e. Downstream Channel — The downstream channel follows the natural path of Curtis Pond Brook. The channel banks are wooded except in the vicinity of the first downstream home, which is located approximately 500 feet from the dam. At this point, the brook widens to form a small pool. Approximately 500 feet further downstream is a second home; and at this point, the channel begins to narrow (Appendix D, Sheet D-14). A small bridge supporting a driveway owned by S. Curtis and Sons, Inc., is located 1,400 feet from the dam. In addition, within a 600-foot-long reach beyond the bridge is the S. Curtis and Sons, Inc., factory and 3 homes.

3.2 EVALUATION

Based on the visual inspection of Curtis Pond Dam, it has been determined that the structures are in generally poor condition. The following features may influence the future condition and/or stability of the structures:

- (1) Deteriorated surface concrete on the spillway training walls may be indicative of generally poor concrete in the interior of these structures. Seepage through the training walls and at the concrete-embankment interface could result if the deterioration is extensive.
- (2) The lack of slope protection on the upstream face of the dam will result in further erosion.

- (3) The growth of trees and brush over the entire dam and the fire canal containment dike will deteriorate the structures and induce seepage along the root networks. Also, high winds may uproot large trees, causing an immediate failure of the dike or dam. The presence of many overhanging trees hinders drainage by contributing to the accumulation of debris in the outlet channel and in the fire canal.
- (4) The absence of a functional low-level outlet will make repairs on the structures difficult and drawdown of the pond during an emergency impossible.
- (5) Wet areas along the toe of the dam and dike are indications of seepage through the embankments. This seepage could adversely affect the stability of the structures.

SECTION 4: OPERATIONAL AND MAINTENANCE PROCEDURES

4.1 OPERATIONAL PROCEDURES

a. General — The dam is used to supply water for the fire protection equipment at S. Curtis and Sons, Inc. As a result, flow normally passes over the concrete spillway and is only diverted through the fire canal during emergencies at the factory or to test the fire protection equipment.

b. Description of any Warning System in Effect — There is no formal downstream warning system in effect at the site.

4.2 MAINTENANCE PROCEDURES

a. General — Currently, there are no formal programs of maintenance or inspection at the dam. However, according to a representative from S. Curtis and Sons, Inc., semiannual inspections of the fire canal and the related equipment are conducted by the company's insurance agent.

b. Operating Facilities — The fire protection system represents the only operable facility currently existing at the site. Water from the fire canal is drawn through two intakes and diverted to the pumphouses, via 8-inch feedlines, where it is then pumped to the sprinkler system in the S. Curtis and Sons, Inc., factory. There are, however, no operable facilities that are related to the regular discharge of water from the dam site and no operations manual for Curtis Pond Dam.

4.3 EVALUATION

The operation and maintenance procedures currently employed at the site are poor. Maintenance of the dam should be scheduled regularly, and technical inspections conducted annually. Records documenting the operation of the facility should be kept for future reference. In

addition, a formal downstream warning system and emergency operation guidelines should be established. Remedial measures and recommendations for the improvement of the facility are presented in Section 7.

SECTION 5: EVALUATION OF HYDRAULIC/HYDROLOGIC FEATURES

5.1 GENERAL

The watershed is 1.66 sq. mi. of relatively undeveloped, rolling, wooded terrain. The highest point along the ridge line that borders the drainage area has an elevation of 600.0, and the elevation of the streambed of Curtis Pond Brook at the confluence with the Pootatuck River is approximately 260.0. The dam is an earthfill embankment with a broad-crested concrete spillway located in the midsection of the dam.

The dam and appurtenant structures are in poor condition. The embankment is covered with mature trees, the slopes show signs of erosion, and there are wet areas along the downstream toe. The concrete spillway training walls have deteriorated and the riprap on the spillway apron is displaced or missing and is obstructed by trees and debris. The low-level outlet operator and its supporting platform have been destroyed; and as a result, the low-level outlet is no longer operable.

5.2 DESIGN DATA

No design data could be found for the original dam construction, but preliminary stability calculations were obtained for the reconstruction of the spillway in 1956 (see Appendix B).

5.3 EXPERIENCE DATA

The original dam, built in 1856, was partially breached by a flood in October 1955. The spillway section of the dam was reconstructed in 1956.

5.4 TEST FLOOD ANALYSIS

The maximum potential storage capacity of Curtis Pond Dam (80 ac-ft) is within the lower limits of the small size category, and the height of the structure (14 feet) is smaller than the height criteria established by the Corps in the "Recommended Guidelines for Safety Inspection of Dams", dated September 1979, for the small size category. The hazard classification for the dam is HIGH, since there is the potential for the loss of more than a few lives due to the breach of the dam. Based on the storage capacity, height, and hazard the recommended test flood for this dam is between one-half the Probable Maximum Flood (1/2 PMF) and the Probable Maximum Flood (PMF). Since the size classification (SMALL) is marginal based on the height and storage of the structure, the test flood will be equivalent to one-half the Probable Maximum Flood (1/2 PMF). The peak inflow to the reservoir due to this flood in a 1.66 sq. mi. rolling watershed is 1,087 cfs/sq. mi. The inflow due to the test flood (1,805 cfs) and resulting outflow (1,670 cfs) will cause the water surface elevation within the impoundment to rise to 332.2 or 1.2 feet above the top of the dam. The capacity of the spillway is 620 cfs with the water surface at the top of the dam (El. 331.0) or 37 percent of the routed test flood outflow.

5.5 DAM FAILURE ANALYSIS

Utilizing the "Rule of Thumb Guidance for Estimating Downstream Dam Failure Hydrographs", dated April 1978, the failure outflow was calculated to be 7,320 cfs with the water surface, within the impoundment, at the top of the dam. The width of the breach was approximately 76 feet and did not include the spillway section. The failure of Curtis Pond Dam will cause the water surface within the first 500 feet of the downstream channel to rise from 4.0 feet at a pre-failure outflow of 620 cfs to 14.0 feet at a failure outflow of 7,320 cfs. Within the next 500-foot-long reach, the water surface will rise from 6.0 feet at a pre-failure outflow of 620 cfs to 14.7 feet of a failure outflow of 6,491 cfs. Since the channel cross-sectional features 600 feet beyond

the preceding 500-foot reach are similar, the flood wave impact in both reaches will be comparable. As a result, the dam failure will flood the first floor of one home to a depth of approximately 6 feet and three homes to a depth of 4 to 5 feet. The S. Curtis and Sons, Inc., factory building and one additional home will experience less than a foot of flooding. No prefailure flooding is anticipated. The dam failure will damage 5 homes, 1 factory, and the bridge supporting the S. Curtis and Sons, Inc., driveway and could potentially cause the loss of more than a few lives. Therefore, the dam has been classified as having a HIGH hazard potential.

SECTION 6: EVALUATION OF STRUCTURAL STABILITY

6.1 VISUAL OBSERVATION

The visual inspection did not reveal any indications of immediate stability problems. However, seepage, erosion, and extensive tree growth were noted on the embankments.

6.2 DESIGN AND CONSTRUCTION DATA

Detailed design and construction data were not available to perform an in-depth assessment of the structural stability of the dam.

6.3 POST-CONSTRUCTION CHANGES

The concrete spillway containing the 24-inch-diameter low-level outlet was constructed within the original dam embankment in 1956 after the dam was breached in October 1955. Plans for replacing the original 30-inch fire canal intake culvert with an 18-inch conduit were also developed at this time (see Appendix B, Sheet B-6). These plans were developed by Austin and Warner Consulting Engineers; however, no documentation was available pertaining to the actual installation of the new conduit. In addition, a quarry has been developed approximately 500 feet east of the dam since its construction in 1856.

6.4 SEISMIC STABILITY

The dam is in Seismic Zone 1 and, according to the Recommended Guidelines, need not be evaluated for seismic stability.

SECTION 7: ASSESSMENT, RECOMMENDATIONS AND REMEDIAL MEASURES

7.1 DAM ASSESSMENT

a. Condition — The visual inspection of the facility and an evaluation of its past performance reveal that the dam is in poor condition. No evidence of immediate structural instability was observed in the earthfill embankments and the concrete spillway training walls. However, the embankments and spillway training walls are in generally poor condition with many areas requiring maintenance and/or monitoring.

Based on the "Rule of Thumb Guidance for Estimating Downstream Dam Failure Hydrographs", dated April 1978, and the hydraulic/hydrologic computations, the peak inflow and outflow for the test flood are 1,805 cfs and 1,670 cfs, respectively. The spillway capacity with the water surface at the top of the dam (El. 331.0 NGVD) is 620 cfs or 37 percent of the routed test flood outflow.

b. Adequacy of Information — The information available is such that an assessment of the condition and stability of the dam must be based largely on the visual inspection, past performance, and sound engineering judgement.

c. Urgency — It is recommended that the measures presented in Sections 7.2 and 7.3 be implemented within one (1) year of the owner's receipt of this report.

7.2 RECOMMENDATIONS

It is recommended that the owner employ a qualified registered professional engineer to:

- (1) Determine the origin of the seepage through the embankments (dam embankments and canal dike) and evaluate its influence on

structural stability. A program to reduce or stop this seepage should be developed depending on the severity of the problem.

- (2) Investigate and evaluate the condition of the spillway training wall concrete and the fire canal intake conduit. If warranted, a program for the restoration of these structures should be developed.
- (3) Assess the need for and means to provide a low-level regulating outlet that would allow drawdown of the pool.
- (4) Riprap should be sized by the engineer and placed on the upstream slope.
- (5) Perform a detailed hydrologic-hydraulic investigation to assess further the potential of overtopping the dam and the need for and the means to increase project discharge capacity.
- (6) Perform a detailed topographic survey identifying the dam, impoundment, and all appurtenant structures. From this survey, a complete set of drawings indicating all pertinent features at the site should be developed and filed for future reference.
- (7) The eroded areas on the upstream and downstream slopes of the embankment and along the spillway training walls should be backfilled with suitable compacted material.
- (8) Remove all trees and saplings from slopes including the roots. Resulting voids should be backfilled with suitable compacted material.

The Owner should implement the recommendations of the Engineer.

7.3 REMEDIAL MEASURES

a. Operation and Maintenance Procedures - The following measures should be undertaken within one (1) year of the owner's receipt of this report and continued on a regular basis.

- (1) A formal program of operation and maintenance procedures should be instituted and documented to provide accurate records for future reference.
- (2) Clean and repair the spillway apron.
- (3) Implement and intensify a program of diligent and periodic maintenance including, but not limited to: mowing brush on slopes, backfilling animal burrows with suitable well tamped material, and cleaning debris from spillways and slopes.
- (4) Prepare a formal written emergency action plan to include surveillance of the dam during flood conditions and a downstream warning system.
- (5) Institute a program of annual technical inspection by a qualified registered professional engineer.
- (6) Repair the spalled areas on the waste weir.

7.4 ALTERNATIVES

This study has identified no practical alternatives to the above recommendations.

APPENDIX A

VISUAL CHECK LIST WITH COMMENTS

VISUAL INSPECTION CHECK LIST
PARTY ORGANIZATION

PROJECT Curtis Pond Dam

DATE 12/11/80

TIME 1:30 p.m.

WEATHER Clear, Cold, 28°F

W.S. ELEV. 327.1

PARTY:

INITIALS:

- | | |
|------------------------|--------------------------|
| 1. Reynold A. Hokenson | RAH |
| 2. Miron B. Petrovsky | MBP |
| 3. Jerry Waugh | JW |
| 4. Ernst H. Buggisch | EHB |
| 5. Mike Pazzato | MP (Matthews Associates) |

PROJECT FEATURE:

INSPECTED BY:

- | | |
|---|-----------------------|
| 1. Dam Embankments | MBP, JW |
| 2. Low-Level Outlet | RAH, MBP, JW |
| 3. Spillway and Low-Level Outlet
Channel | MBP, JW |
| 4. Spillway | RAH, JW |
| 5. Fire Canal | RAH, MBP, MP, EHB, JW |

PERIODIC INSPECTION CHECK LIST

PROJECT: Curtis Pond Dam

DATE: 12/11/80

PROJECT FEATURE: Dam Embankments

NAME: MBP, JW

AREA EVALUATED	CONDITION
<u>DAM EMBANKMENT</u>	
Crest Elevation	331
Current Pool Elevation	327.1
Maximum Impoundment to Date	Dam overtopped during flood of October 1955.
Surface Cracks	None
Pavement Condition	N/A
Movement or Settlement of Crest	None
Lateral Movement	None
Vertical Alignment	Good
Horizontal Alignment	Good
Condition at Abutment and at Concrete Structures	Severe deterioration of spillway training wall concrete.
Indications of Movement of Structural Items on Slopes	None
Trespassing on Embankment	No extensive trespassing. No animal burrows were noted, but beavers have been cutting trees. Extensive growth of mature trees was found on the embankment.
Sloughing or Erosion of Slopes	Adjacent to spillway walls and along upstream slope.
Rock Slope Protection - Riprap Failures	No riprap is present allowing slope erosion.
Unusual Movement or Cracking at or near Toes	None

PERIODIC INSPECTION CHECK LIST

PROJECT: Curtis Pond Dam

DATE: 12/11/80

PROJECT FEATURE: Dam Embankments (Continued)

NAME: MBP, JW

AREA EVALUATED	CONDITION
Unusual Embankment or Downstream Seepage	Seepage at toe of embankment dam.
Piping or Boils	None
Foundation Drainage Features	N/A
Toe Drains	None
Instrumentation System	None

PERIODIC INSPECTION CHECK LIST

PROJECT: Curtis Pond Dam

DATE: 12/11/80

PROJECT FEATURE: Low-level Outlet

NAME: RAH, MBP, JW

AREA EVALUATED	CONDITION
<p><u>OUTLETS WORKS - INTAKE CHANNEL AND INTAKE STRUCTURE</u></p> <p>a. Approach Channel</p> <p style="padding-left: 40px;">Slope Conditions</p> <p style="padding-left: 40px;">Bottom Conditions</p> <p style="padding-left: 40px;">Rock Slides or Falls</p> <p style="padding-left: 40px;">Log Boom</p> <p style="padding-left: 40px;">Debris</p> <p style="padding-left: 40px;">Condition of Concrete Lining</p> <p style="padding-left: 40px;">Drains or Weep Holes</p> <p>b. Intake Structure</p> <p style="padding-left: 40px;">Condition of Concrete</p> <p style="padding-left: 40px;">Stop Logs and Slots</p>	<p>Curtis Pond is the approach channel for the dam. The banks of the pond are wooded and showed no signs of significant erosion or instability.</p> <p>The intake structure for the low-level outlet consisted of a gated conduit operated from a platform extending over the spillway from the right training wall. Neither the platform nor the operator exist.</p>

PERIODIC INSPECTION CHECK LIST

PROJECT: Curtis Pond Dam DATE: 12/11/80

PROJECT FEATURE: Low-level Outlet (Continued) NAME: RAH, MBP, JW

AREA EVALUATED	CONDITION
<p><u>OUTLET WORKS - CONTROL TOWER</u></p> <p>a. Concrete and Structural</p> <p> General Condition</p> <p> Condition of Joints</p> <p> Spalling</p> <p> Visible Reinforcing</p> <p> Rusting or Staining of Concrete</p> <p> Any Seepage or Efflorescence</p> <p> Joint Alignment</p> <p> Unusual Seepage or Leaks in Gate Chamber</p> <p> Cracks</p> <p> Rusting or Corrosion of Steel</p> <p>b. Mechanical and Electrical</p> <p> Air Vents</p> <p> Float Wells</p> <p> Crane Hoist</p> <p> Elevator</p> <p> Hydraulic System</p> <p> Service Gates</p> <p> Emergency Gates</p> <p> Lightning Protection System</p> <p> Emergency Power System</p> <p> Wiring and Lighting System</p>	<p>The platform supporting the low-level outlet control mechanism has been destroyed.</p> <p>N/A</p>

PERIODIC INSPECTION CHECK LIST

PROJECT: Curtis Pond Dam

DATE: 12/11/80

PROJECT FEATURE: Low-Level Outlet (Continued)

NAME: RAH, MBP, JW

AREA EVALUATED	CONDITION
<p><u>OUTLET WORKS - TRANSITION AND CONDUIT</u></p> <p>General Condition of Concrete</p> <p>Rust or Staining on Concrete</p> <p>Spalling</p> <p>Erosion or Cavitation</p> <p>Cracking</p> <p>Alignment of Monoliths</p> <p>Alignment of Joints</p> <p>Numbering of Monoliths</p>	<p>The low-level outlet consists of a 24" conduit. The outlet extends through the concrete spillway and discharges on the riprap apron beyond the spillway. The condition of the pipe and surrounding concrete appear to be good. No leakage from the outlet was noticed.</p>

PERIODIC INSPECTION CHECK LIST

PROJECT: Curtis Pond Dam

DATE: 12/11/80

PROJECT FEATURE: Spillway and Low-Level Outlet Channel

NAME: MBP, JW

AREA EVALUATED	CONDITION
<p><u>OUTLET WORKS - OUTLET STRUCTURE AND OUTLET CHANNEL</u></p> <p>General Condition of Concrete</p> <p>Rust or Staining</p> <p>Spalling</p> <p>Erosion or Cavitation</p> <p>Visible Reinforcing</p> <p>Any Seepage or Efflorescence</p> <p>Condition at Joints</p> <p>Drain holes</p> <p>Channel</p> <p>Loose Rock or Trees Overhanging Channel</p> <p>Condition of Discharge Channel</p>	<p>N/A</p> <p>Mature trees and bushes were noted within and along the outlet channel.</p> <p>Debris has accumulated at the base of the spillway and obstructs the low-level outlet.</p>

PERIODIC INSPECTION CHECK LIST

PROJECT: Curtis Pond Dam

DATE: 12/11/80

PROJECT FEATURE: Spillway

NAME: RAH, JW

AREA EVALUATED	CONDITION
<p><u>OUTLET WORKS - SPILLWAY WEIR, APPROACH AND DISCHARGE CHANNELS</u></p> <p>a. Approach Channel</p> <p> General Condition</p> <p> Loose Rock Overhanging Channel</p> <p> Trees Overhanging Channel</p> <p> Floor of Approach Channel</p> <p>b. Weir and Training Walls</p> <p> General Condition of Concrete</p> <p> Rust or Staining</p> <p> Spalling</p> <p> Any Visible Reinforcing</p> <p> Any Seepage or Efflorescence</p> <p> Drain Holes</p> <p>c. Discharge Channel</p> <p> General Condition</p> <p> Loose Rock Overhanging Channel</p> <p> Trees Overhanging Channel</p> <p> Floor of Channel</p> <p> Other Obstructions</p>	<p>N/A</p> <p>The training walls are judged to be in poor condition. The spillway weir is in good condition.</p> <p>Excessive on training walls.</p> <p>Excessive on training walls.</p> <p>Along the top of the training walls.</p> <p>Efflorescence noted on all wall surfaces.</p> <p>None</p> <p>Fair</p> <p>None</p> <p>Immediately downstream of dam.</p> <p>Displaced and missing riprap in apron. Debris on apron.</p> <p>Shopping carriage, tires, and assorted rubbish.</p>

PERIODIC INSPECTION CHECK LIST

PROJECT: Curtis Pond Dam

DATE: 12/11/80

PROJECT FEATURE: Not Applicable

NAME: _____

AREA EVALUATED	CONDITION
<p><u>OUTLET WORKS - SERVICE BRIDGE</u></p>	
<p>a. Super Structure</p> <ul style="list-style-type: none"> Bearings Anchor Bolts Bridge Seat Longitudinal Members Under Side of Deck Secondary Bracing Deck Drainage System Railings Expansion Joints Paint 	<p>N/A</p>
<p>b. Abutment & Piers</p> <ul style="list-style-type: none"> General Condition of Concrete Alignment of Abutment Approach to Bridge Condition of Seat & Backwall 	<p>N/A</p>

PERIODIC INSPECTION CHECK LIST

PROJECT: Curtis Pond Dam

DATE: 12/11/80

PROJECT FEATURE: Fire Canal and Dike

NAME: RAH, MBP, MP, EHB, JW

AREA EVALUATED	CONDITION
Fire Canal	A significant amount of debris has accumulated in the canal. No flow in the canal during the inspection.
Dike	The dike is heavily wooded. Trees ranging from 3 to 15 inches in diameter were noted. The top of the dike has several low areas and varied in width. In addition, a wet area was noted at the toe of the dike near the intersection with the main dam.
Fire Canal Intake	Inaccessible due to the debris in the canal. The downstream cut stone and masonry structure showed signs of decay at the masonry joints.
Waste Weir	No flow. Minor spalling along crest.
Pump Houses and Intakes	Appeared to be in relatively good condition. The intake trashracks were clear and there were no obstructions in either intake.

APPENDIX B

ENGINEERING DATA

SUMMARY OF DATA AND CORRESPONDENCE

<u>DATE</u>	<u>TO</u>	<u>FROM</u>	<u>SUBJECT</u>	<u>PAGE</u>
9/7/64	----	----	Water Resource Inventory Sheet	B-3
7/29/73	Connecticut DEP	S. Curtis & Sons	Recommended Maintenance	B-4
4/29/73	S. Curtis & Sons	Connecticut DEP	Compliance to Recommendations	B-5
9/26/56	Dean Clark State Board of Dams	Austin & Warner	Renovation of Intake Conduit	B-6
9/19/56	Dean Clark	Austin & Warner	Inspection of New Spillway	B-7
9/4/56	W. S. Wise Director, State Water Commission	W. H. Loughran	Public concern over Spillway reconstruction	B-8
7/27/56	S. Curtis & Sons	Board of Supervision of Dams (BSD)	Preliminary Permit	B-10
7/27/56	Dean Clark	Austin & Warner	Notification of Design Revisions	B-14
7/24/56	Dean Clark	M. E. Hupfer	Design Calculations checked	B-17
7/23/56	Mr. J. Curry State Water Commission	Austin & Warner	Submission of Design	B-18
7/3/56	Dean Clark	Austin & Warner	Submission of Design	B-21
5/23/56	Dean Clark	J. J. Curry	Rejection of Saddle Spillway	B-22
5/15/56	BSD	H. H. Cutler Town Clerk	Application for Construction	B-23

SUMMARY OF DATA AND CORRESPONDENCE
(continued)

<u>DATE</u>	<u>TO</u>	<u>FROM</u>	<u>SUBJECT</u>	<u>PAGE</u>
---	---	---	Preliminary Calculations	B-28
5/8/56	Dean Clark	Austin & Warner	Saddle Spillway Design Submission	B-30
1/20/56	S. Curtis & Sons	Dean Clark	Account of Clark's inspection	B-39
1/3/56	S. Curtis & Sons	BSD	Permission to renovate dam	B-40
12/7/55	BSD	S. Curtis & Sons	Request for Information on Jurisdiction	B-41

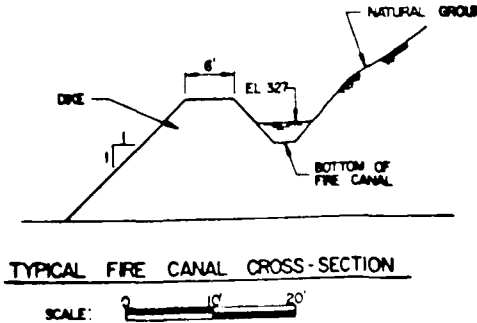
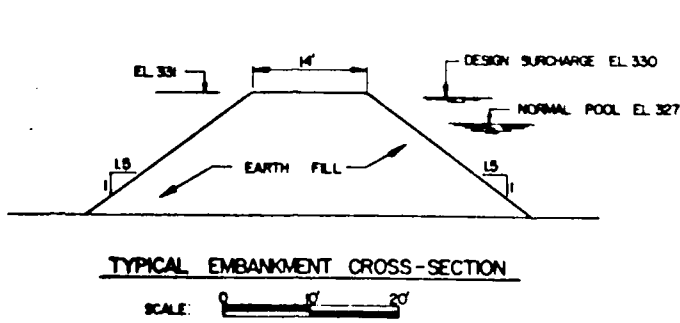
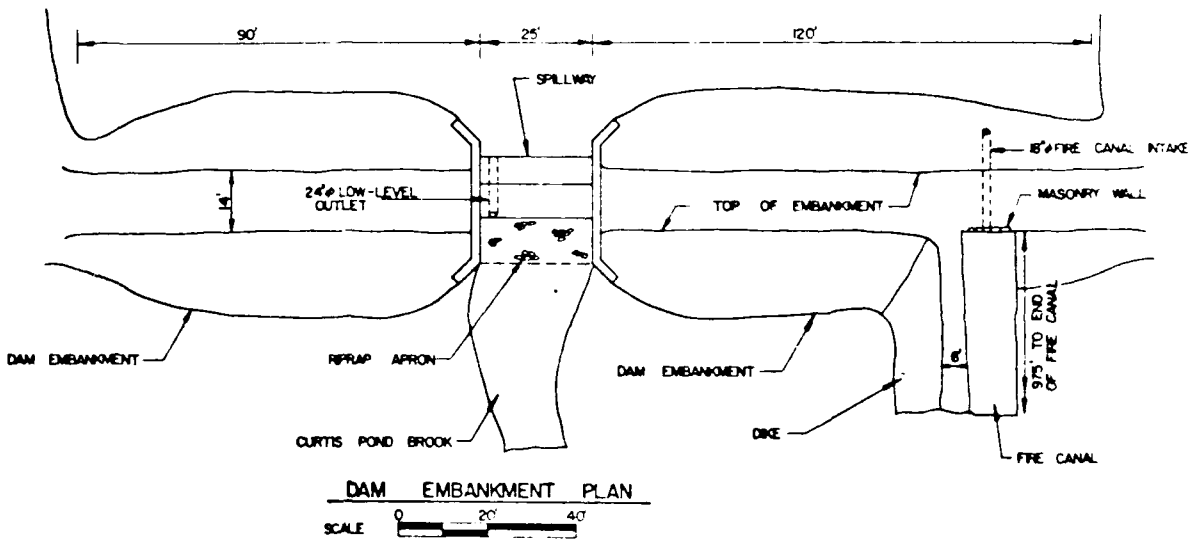
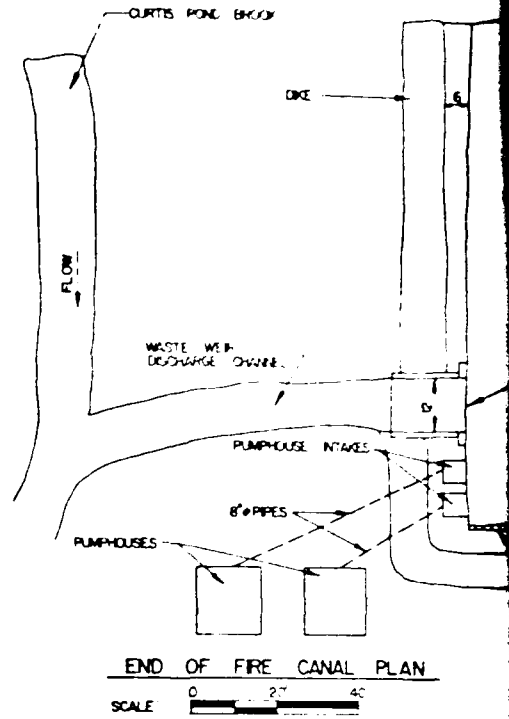
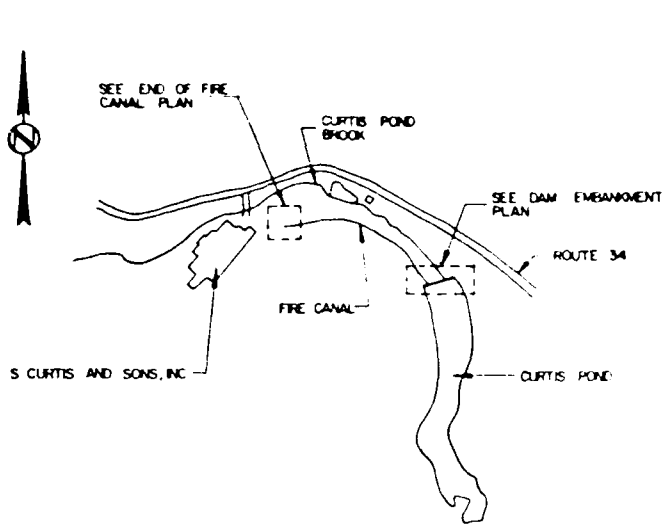

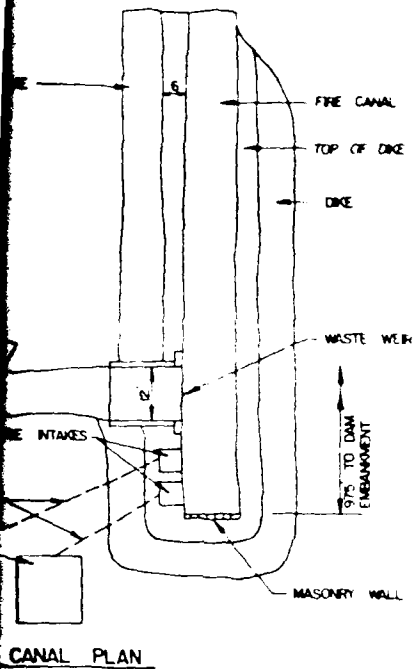

CANAL PLAN

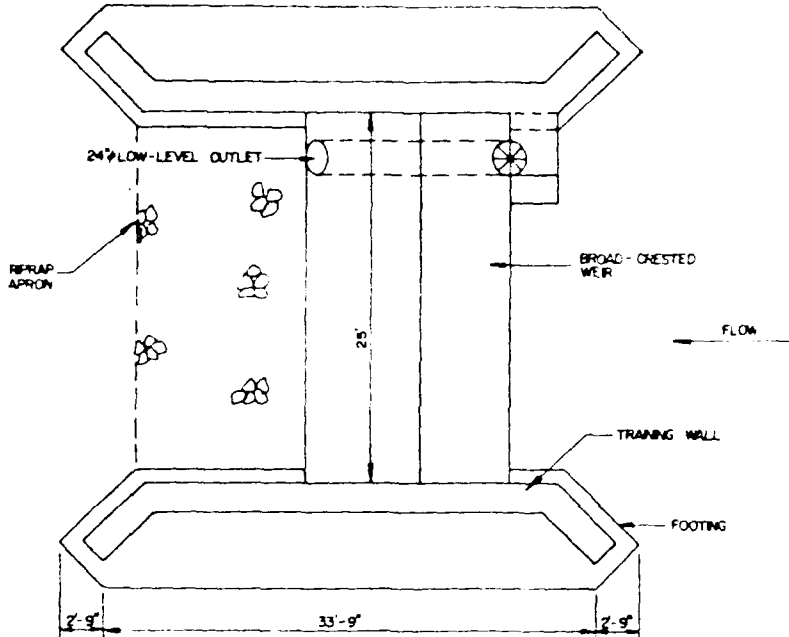

SPILLWAY PLAN

SCALE 0 2 4 6 8

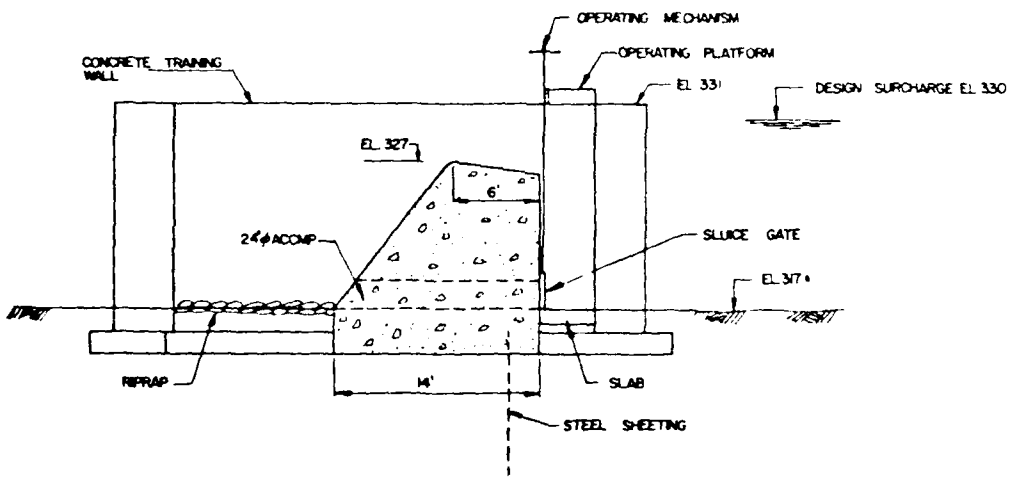

SPILLWAY SECTION

SCALE 0 6 12

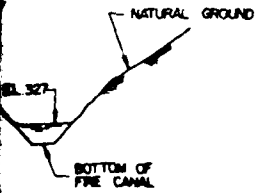

CROSS-SECTION

NOTES:

1. THIS PLAN WAS COMPILED FROM THE EXISTING DESIGN DRAWINGS FOR THE CURTIS POND DAM RECONSTRUCTION, PREPARED BY ALSTIN AND WARNER CONSULTING ENGINEERS (1966) AND SUPPLEMENTARY FIELD OBSERVATIONS MADE BY IECO ENGINEERS
2. ALL THE ELEVATIONS WERE COMPUTED FROM THE AVAILABLE DRAWINGS, ASSUMING THAT THE SPILLWAY CREST ELEVATION CORRESPONDS TO THE POND SURFACE ELEVATION SHOWN ON THE NEWTOWN, CONNECTICUT, USGS QUADRANGLE MAP
3. THE OPERATING PLATFORM AND OPERATING MECHANISM WERE MISSING AT THE TIME OF THE INSPECTION.

INTERNATIONAL ENGINEERING CO DARIEN, CONNECTICUT ENGINEER		U.S. ARMY ENGINEER DIV NEW ENGLAND CORPS OF ENGINEERS WALTHAM, MASS	
NATIONAL PROGRAM OF INSPECTION OF NON-FEDERAL DAMS			
PLAN AND SECTIONS CURTIS POND DAM			
CURTIS POND BROOK		NEWTOWN, CONNECTICUT	
DRAWN BY M. Williams	CHECKED BY C. G. ...	APPROVED BY A. ...	SCALE AS NOTED
		DATE JAN 1981	SHEET 8-1

No. N1-11

WATER RESOURCES COMMISSION
SUPERVISION OF DAMS
INVENTORY DATA

Long 73-15.5

Lat 41-29.4

Inventoried By WPS

Date 17 SEPTEMBER 1964

Name of Dam or Pond CURTIS POND

Code No. H 28.4 PK 3.6 CS 0.8

Nearest Street Location ROUTE 34

Town NEWTOWN

U.S.G.S. Quad. NEWTOWN

Name of Stream CURTIS BROOK

Owner S. CURTIS AND SON, INC.

Address SANDY HOOK, CONN.

OK
1/13

DA 1.163M

Pond Used For FIRE PROTECTION, FACTORY WATER 9A

Dimensions of Pond: Width 200 FEET Length 1300 FEET Area 26 ACRES

Total Length of Dam ^{168'} 152 FEET Length of Spillway 35 FEET

Location of Spillway CENTER OF DAM

Height of Pond Above Stream Bed ^{7.8'} 12 FEET 9.5'

Height of Embankment Above Spillway 4 FEET

Type of Spillway Construction CONCRETE

Type of Dike Construction CONCRETE, EARTH

Downstream Conditions HOUSES, FACTORY

Summary of File Data PRELIMINARY PERMIT DATED 7-27-56 FOR REPAIR AND CERTIFICATE OF APPROVAL DATED 9-24-56. SEPARATE FILE

Remarks _____

Would Failure Cause Damage? B-3 YES Class B

1956
Revised
1956



STATE OF CONNECTICUT
DEPARTMENT OF ENVIRONMENTAL PROTECTION

State Office, 150 Capitol Building, Hartford, Connecticut 06103

24 July 1973

JERRY W. HUNTER
Commissioner

WATER AND RELATED RESOURCES

S. Curtis & Son, Inc.
Sandy Hook, Connecticut

Re: Curtis Pond Dam
Newtown (N-3)

Dear
~~xxxx~~ Gentlemen:

According to the records in this office the above mentioned dam is under your ownership.

Section 13, (Public Act No. 571, 1973 Session of the General Assembly) a copy of which is enclosed, places under the jurisdiction of this department all dams, which by breaking away or otherwise, might endanger life or property. It has been determined that this dam is under the jurisdiction of this department.

In accordance with Section 25-111 (1971 Supplement) of the General Statutes, this dam has been inspected. In order to maintain your dam in a safe condition the following work must be done, or steps taken:

1. The debris in the spillway should be removed.
2. The brush and small trees growing on the dike should be cut.

The Water and Related Resources Unit of the Department of Environmental Protection shall be notified within two weeks what steps you plan to take to place your structure in a safe category.

Very truly yours,

Victor E. Galgowski
Samuel Suffern, Deputy Director
By Victor E. Galgowski
Supt. of Dam Maintenance

JSS:VFG:ljg

Enclosure



S. CURTIS & SON, INC.

BOXBOARD AND PLASTICS PACKAGING

SANDY HOOK, CONNECTICUT 06482

TELEPHONE 203 426-4421

October 29, 1973

Mr. Victor F. Galgowski
Supt. of Dam Maintenance
Water and Related Resources Unit
Department of Environmental Protection
State of Connecticut
State Office Building
Hartford, Connecticut 06115

Dear Mr. Galgowski;

Reference your notice regarding the Curtis Pond Dam, Newtown
(N-3), dated July 24, 1973.

The work you requested to be done has been completed.

Sincerely,

S. CURTIS AND SON, INCORPORATED

Donald W. Leavitt,
Personnel Manager

DWL:bh

WATER & RELATED
RESOURCES
RECEIVED

OCT 30 1973

ANSWERED _____
REFERRED _____
FILED _____



AUSTIN and WARNER

Consulting Engineers

BRowning 2-5258

BRowning

2-5386

871 WEST MAIN STREET

P.O. BOX 295

WEST CHESHIRE, CONN.

September 26, 1956

Mr. Dean Clark
State Board for Dams
2 Sachem Road
Greenwich, Conn.

*as suggested at
time of inspection*

Dear Mr. Clark:

Enclosed are two photographs which show the underground conduit which connects the dam to the canal to the plant. This was the section that was a little narrower in width than the rest of the dam. Our plan 5323-DM1 shows the ground plan for this dam and the canal connection. I am sending you a copy of this also.

We have recommended that a 20' length of 18" Armco pipe be placed in the mouth of this present 30" opening and mortared in with stone masonry then this pipe back-filled all around to widen this area out to the width of the dam as widen surrounding.

The area originally was the widest part of the dam before we started widening out the rest of it but now it looks like the narrowest part and this new pipe will permit the width to be widened out. The present water level is about 4' 6" below the top of the earthwork and there is never more than about 12" of water flowing through this 30" culvert as it is very well silted up. The level of the canal on the other side is only 12" below the top of the culvert.

Yours truly,

Louis A. Warner, P. E.

LAW/b

Enc. 3

c/c Nelson Curtis

Registered Engineers in Connecticut, New York, Massachusetts, Wisconsin, New Hampshire, Maine and Rhode Island



AUSTIN and WARNER

Consulting Engineers

Browning 2-5258

Browning

2-5386

871 WEST MAIN STREET

P.O. BOX 295

WEST CHESHIRE, CONN.

September 19, 1956

Mr. Dean Clark
State Board for Dams
2 Sachem Road
Greenwich, Conn.

Re: Curtis Dam
Newtown, Conn.

Dear Mr. Clark:

Meeting at New 9/24

The Contractor has completed the construction of the dam and we have instructed him to fill the pond to $\frac{1}{2}$ height and hold it there for your inspection before filling it completely.

It was constructed in accordance with the plans as approved except for deepening the footings where old timber mats were removed. Steel sheet piling was driven 9'-0" to refusal as a cut off wall as shown on the drawings.

Inasmuch as the insurance company has requested this water source be filled, we would appreciate your inspection of this project as soon as convenient.

Yours truly,

AUSTIN & WARNER

Louis A. Warner, P.E.

Louis A. Warner

LAW/b

WILLIAM H. LOUGHRAN

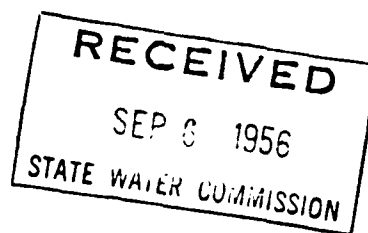

Sandy Hook, Conn.
September 4, 1956

Mr. William S. Wise
Director, State Water Commission
Hartford, Conn.

Dear Mr. Wise:

Governor Ribicoff has suggested that I contact you in connection with a matter of interest to me.

One of the dams washed out in the storms of last year was a small one in Sandy Hook, Conn. which helped to form Berkshire Pond. The water supply from this dam had been used by S. Curtis and Sons, Inc. for a great many years in connection with the operation of their factory.

They are presently building a new dam to replace the old one and I have a great curiosity as to the water level that will result because I own quite some of the shore line on one side of this pond. They have never discussed the erection of the new dam with me, but in reply to a letter written to them, have advised me that the spillway section of the new dam will be approximately the same as the top of the old spillway. I would like to verify this fact and also to ascertain whether they have been given permission to install any "boards" which would help to raise the water level.

I would greatly appreciate a reply to this request.

Very truly yours

A handwritten signature in dark ink, appearing to read "W. H. Loughran".

William H. Loughran

WHL:bb

September 10, 1956

Mr. William H. Loughran
Sandy Hook,
Connecticut

Dear Mr. Loughran:

Reference is made to your letter of September 4th. Please be informed that the S. Curtis and Sons, Inc. have been granted permission by this office to repair the dam on their property.

As far as we can determine the elevation of the spillway will be the same as it was before it was damaged and the submitted plans call for no flashboards atop the dam.

I am enclosing a copy of the law which governs the State Board for the Supervision of Dams. You will note by it that this agency is concerned only with the safety of a dam.

Very truly yours,

E. A. Dell
Sanitary Inspector

EAD/jb

Encl.

STATE OF CONNECTICUT
BOARD OF SUPERVISION OF DAMS

2- 23

PRELIMINARY PERMIT

Greenwich

, Conn.

7/27/56

, 19

To Owner *S. Curtis & Son - Inc*

P. O. Address *Sandy Hook - Conn*

I have inspected the site and have examined the plans marked # *5523-3.D.M.*

& dated 7/21/56 - prepared by Austin & Warner - Engineers

and the specifications therefore, submitted by you to the Board of Supervision of dams for

re-construction of dam at Curtis Pond

on in the Town of *Heaton*

The same are approved, and such proposed construction work is hereby authorized.

Dean Clark

Member, Board of Supervision of Dams

STATE OF CONNECTICUT
BOARD OF SUPERVISION OF DAMS

2- 23

CERTIFICATE OF APPROVAL

Greenwich

, Conn.

7/24/56

, 19

To Owner *S. Curtis & Son - Inc*

P. O. Address *Sandy Hook - Conn*

Name of Structure *Dam*

This is to certify that the following construction work:

new concrete dam in accordance with plan # 5523-3.D.M. prepared by Austin & Warner - dated 7/21/56 performed on property owned by you on *forming Curtis Pond*, in the Town of *Sandy Hook*

for which preliminary permit was issued *7/27/56* has been completed to the satisfaction of this Board and that such structure is approved and has been found to be safe as of date of this certificate.

BOARD OF SUPERVISION OF DAMS

BY

Dean Clark

, Member

Note: The owner is required by law to record this certificate in the Land Records of the town or towns in which the dam or reservoir is located.

STATE OF CONNECTICUT
BOARD OF SUPERVISION OF DAMS

2- 23

CERTIFICATE OF APPROVAL

Greenwich, Conn.
9/21/56, 19

To Owner S. Curtis & Son - Inc
P. O. Address Sandy Hook - Green
Name of Structure Dam

This is to certify that the following construction work: New Concrete Dam in accordance with
Plan # 5523 - 2 DM prepared by Curtis & Wamer - Dated 7/21/56, performed on property owned by you on
forming Curtis Pond, in the Town of Sandy Hook
for which preliminary permit was issued 7/27/56 has been completed to the satisfaction
of this Board and that such structure is approved and has been found to be safe as of date of this certificate.

BOARD OF SUPERVISION OF DAMS

BY

Stan Clark

Member

Note: The owner is required by law to record this certificate in the Land Records of the town or towns in which the dam
or reservoir is located.

September 24, 1956
2 Sachem Road
Greenwich, Conn.

Mr. Nelson G. Curtis, President
S. Curtis & Company
Sandy Hook, Conn.

Dear Mr. Curtis:

Together with Mr. Warner the contractor and yourself an inspection of your new dam was made this morning. The construction according to the plan #5523-3DM prepared by Austin & Warner and dated July 21, 1956 appears to have been well done and in my opinion you have a stable structure.

Please find enclosed certificate of approval #2-23. This completes the record for the State, except that you should record this certificate and approved print of the plan in the office of your Town Clerk.

With kind regards.

Yours very truly,

Dean Clark,
Member of the Board

DC:mmm
Enc.

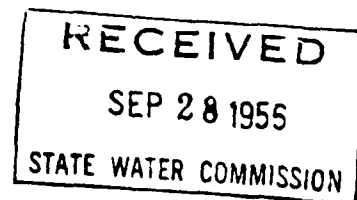

STATE OF CONNECTICUT
BOARD OF SUPERVISION OF DAMS

2- 23

PRELIMINARY PERMIT

7/27/56, Conn.

Greenwich, 19

To Owner S. Curtis & Son - Inc.

P. O. Address Sandy Hook

revised

I have inspected the site and have examined the plans marked # 5523-3 DM

+ dated 7/27/56 - prepared by Austin + Warner - Engineers

and the specifications therefore, submitted by you to the Board of Supervision of dams for

re-construction of dam at Curtis Pond

on in the Town of Greenwich

The same are approved, and such proposed construction work is hereby authorized.

Stan Clark

Member, Board of Supervision of Dams

July 27, 1956
2 Sachem Road
Greenwich, Conn.

Mr. Lewis A. Warner
Box 295
West Cheshire, Conn.

Dear Mr. Warner:

The revisions in your design for the dam for S. Curtis & Son as shown on your print #5523-DM and dated July 21, 1956 together with the stability analysis of the same date have been found satisfactory by our Hartford office.

I am, therefore, enclosing the revised print approved and also preliminary permit #2-23. These should be recorded in the local land records.

For my file will you kindly send me a print of the design as revised.

Yours very truly,

Dean Clark,
Member of the Board

DC:mn

July 27, 1956
2 Sagem Road
Greenwich, Conn.

sent to Curtis & Son

Mr. Lewis A. Warner
Box 295
West Cheshire, Conn.

Dear Mr. Warner:

The revisions in your design for the dam for S. Curtis & Son as shown on your print #5523-DH and dated July 21, 1956 together with the stability analysis of the same date have been found satisfactory by our Hartford office.

I am, therefore, enclosing the revised print approved and also preliminary permit #2-23. These should be recorded in the local land records.

For my file will you kindly send me a print of the design as revised.

Yours very truly,

Dean Clark,
Member of the Board

DC:mm

9/17 - T/S Curtis & Son advised construction proceeding. Completed. Was inspected this week.



AUSTIN and WARNER

Consulting Engineers

BRowning 2-5258

BRowning

2-5386

871 WEST MAIN STREET

P.O. BOX 295

WEST CHESHIRE, CONN.

July 27, 1956

Mr. Dean Clark
State Board for Dams, Dikes, & Reservoirs
2 Sachem Road
Greenwich, Conn.

Re: S. Curtis & Son Dam

Dear Mr. Clark:

Enclosed are two (2) copies of the plans for the Curtis Dam, revised as I discussed with the Engineers in Hartford.

You will note that we have made a complete revision and this now meets with their approval as I have been told by telephone.

Yours truly,

AUSTIN & WARNER

Louis A. Warner, P.E.

LAW/b

Enclosures 2

July 24, 1956

Mr. Dean Clark
2 Sachem Road
Greenwich, Connecticut

Dear Mr. Clark:

We have reviewed the enclosed revised plan, stability analysis and spillway capacity computations for the Curtis Dam in Sandy Hook which were submitted to us by Austin and Warner.

We find that they are satisfactory and recommend that the construction permit be issued. As Mr. Warner wishes to start construction very soon, he will greatly appreciate your prompt action.

Very truly yours,

M. E. Empfer
Senior Engineer

MEH/jb

cc: Mr. Louis A. Warner



AUSTIN and WARNER

Consulting Engineers

BRowning 2-5258

BRowning

2-5386

871 WEST MAIN STREET

P.O. BOX 295

WEST CHESHIRE, CONN.

July 23, 1956

Mr. Jack Curry
State Water Commission
State Office Building
Hartford, Conn.

RECEIVED

JUL 24 1956

STATE WATER COMMISSION

Re: Curtis Dam Reconstruction

Dear Mr. Curry:

Enclosed are copies of our Drawing 5523-3DM and computation sheets for the Curtis Dam revised in accordance with our conversations.

May we have word from your office as soon as possible so that we may proceed during the next "dry?" period.

Yours truly,

Louis A. Warner

LAW:baw

Enclosures 2

CC: Nelson Curtis



AUSTIN and WARNER

Consulting Engineers

BRowning 2-5258

BRowning

2-5386

871 WEST MAIN STREET

P.O. BOX 295

WEST CHESHIRE, CONN.

July 10, 1956

.State Water Commission
.State Office Building
.Hartford, Conn.

Attention: Jack Curry

Enclosed, herewith, is a copy of our letter to you of July 3 and two (2) copies of our Drawing #5523-DM2 to replace those that were lost.

Yours truly,

AUSTIN & WARNER

Louis A. Warner
Louis A. Warner, P. E.

LAW:baw

Enclosures 2

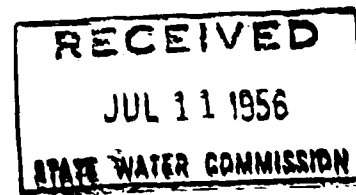

C O P Y

July 3, 1956

State Water Commission
State Office Building
Hartford, Conn.

Attention: Jack Curry

Confirming our conversation of this date concerning the Curtis Dam Reconstruction in Sandy Hook, we are enclosing two copies of our Drawing #5523-DM2 showing the concrete gravity dam as we discussed for your approval. I am also sending a copy of this letter to Mr. Dean Clark with two copies of the drawing having been previously sent to him. It is our understanding that you are, in general, in agreement with this type of construction and that you will give us your comments within the next few days.

As we discussed, if during excavating, the nature of the materials indicate that an up stream cut-off wall of wood sheeting is necessary, we will provide same.

Thank you for your cooperation in this matter.

Yours truly,

AUSTIN & WARNER

Louis A. Warner, P. E.

LAN:baw
Enclosure

CC: Dean Clark
Nelson Curtis



AUSTIN and WARNER

Consulting Engineers

BRowning
2-5386

871 WEST MAIN STREET

BRowning 2-5258

P.O. BOX 295

WEST CHESHIRE, CONN.

July 2, 1956

Mr. Dean Clark
2 Sachem Road
Greenwich, Conn.

Dear Mr. Clark:

Enclosed, herewith, are two copies of our Drawing 5523-DM2 showing a concrete gravity dam for the Curtis pond, as I discussed with you on the telephone. We are in the process of talking with Mr. Curry concerning approval of same. We will write you a copy of a letter at the outcome of our conference tomorrow at 10:30 A.M.

Yours truly,

Louis A. Warner

LAW:baw

Enclosures 2

May 23, 1956

Mr. Dean Clark
2 Sachem Road
Greenwich, Connecticut

Dear Mr. Clark:

Reference is made to our telephone conversation of this morning in which you asked for our comments on the plans for proposed rebuilding of the dam at Curtis Pond, Sandy Hook, submitted to this Commission May 15.

We have checked the design of this dam and find that the spillway capacity is adequate and complies with the figures presented to the applicant in your letter of January 20th. The general layout of the dam and the appurtenances conform with the established policies of the Commission. However, we would like to direct attention to one feature of the design.

The spillway section of the dam is to consist of an 8-inch paving of concrete reinforced by wire mesh to be laid on an approved compact clayey sand fill. Specifications for the compaction that will be acceptable are not indicated. It appears to us, however, that regardless of the specifications imposed some shrinkage or compaction of the earth material is certain. This shrinkage will be further promoted by the fact that the earth fill can be alternately wet and dry and will generally be wet. When such shrinkage occurs the concrete pavement would only be supported at the toes. It is doubtful whether such a pavement would not be subject to cracking under these conditions. Any cracking which allowed seepage into the earth section of the dam could accentuate the dangerous condition in a relatively short period. It is suggested that this point be discussed with the designer to obtain his assessment of the condition and to determine if there is a suitable safeguard to prevent the possibility of failure in this manner.

Very truly yours,

John J. Curry
Chief Engineer

JJC/jb

TOWN OF NEWTOWN
NEWTOWN, CONN.



OFFICE OF
HERBERT H. CUTLER
TOWN CLERK AND REGISTRAR

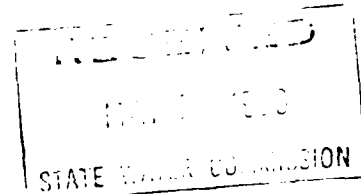

May 15, 1956

State Board for the Supervision of Dams
State Office Building
Hartford 15, Conn.

Attention: Mr. William S. Wise, Chairman

Gentlemen:

We are enclosing herewith in duplicate the application of S. Curtis and Son, Inc., Sandy Hook, Conn., for a construction permit for the rebuilding of their dam and spillway on Curtis Pond, Sandy Hook, together with two copies of a blueprint of the proposed construction drawn by Austin and Warner and dated April 16, 1956.

Very truly yours,

Herbert H. Cutler
Town Clerk

HHC/w
Enc. 2

STATE BOARD OF SUPERVISION OF DAMS

APPLICATION FOR CONSTRUCTION PERMIT
As required under Section 4731 of General Statutes

THIS APPLICATION TO BE SUBMITTED IN TRIPLICATE

RECEIVED
MAY 10 1956
STATE BOARD OF SUPERVISION OF DAMS

Owner S. CURTIS & SON, INC

Date 5/10/56

P. O. Address SANDY HOOK,
NEWTOWN, CONN

Tel. No. Garden 6-4421

Location of Structure:
Town SANDY HOOK

Shown on USGS Quadrangle NEWTOWN

Name of Stream CURTIS POND

at 1 inches south of Lat. 41°-25'-00"
north
abd 3 inches east of Long. 73°-17'-30"
west

Directions for reaching site from nearest village or route intersection:

(See sketch on reverse side)
TRAVEL EAST ON ROUTE 34 FROM INTERSECTION OF RT 6
ABOUT 1/4 MILES - ON RIGHT HAND SIDE

This is an application for: REPAIR OF SPILLWAY
(New Construction) (Alteration) (Repair) (Removal)
(describe project)

This pond is to be used for: FIRE PROTECTION - FACTORY WATER

Dimensions of pond: width 200 FT length 1300 FT area APPROX 260000

Depth of water below spillway level: 8-10 FT (AVERAGE DEPTH 4-5)

Total length of dam: ABOUT 150 FT

Length of spillway: 35 FT

Height of abutments above spillway: 3'-0"

Type of spillway construction: CONCRETE SADDLE

Type of dyke construction: EARTH FILL (HYDRAULIC)

Character of soil in river bed at spillway location: SANDY

Remarks: THIS IS A REPAIR TO A DAM SPILLWAY
WASHED OUT DURING THE NOV. FLOOD

Note: Show details of construction on reverse side.

Signed James L. Warner P.E.

Helen G. Curtis, Pres.
S. Curtis & Son, Inc

LOCATION SKETCH

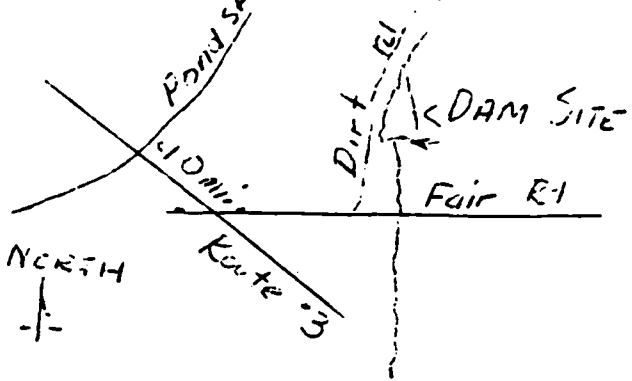

SITE PLAN

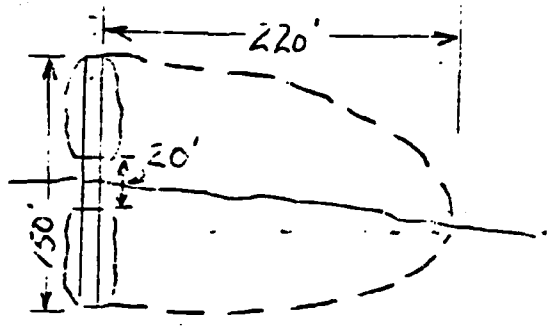

SPILLWAY SECTION

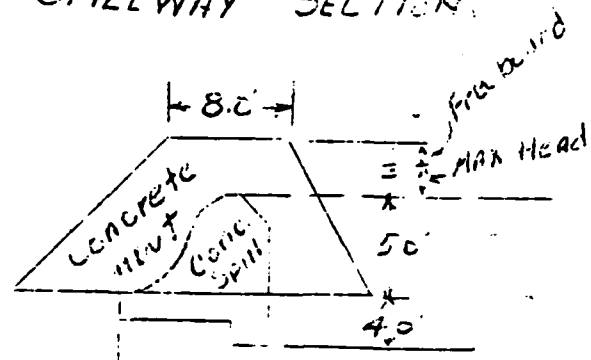

NOTE - IF THERE ARE TWO METHODS OF DISCHARGE SHOW BOTH

DIKE SECTION

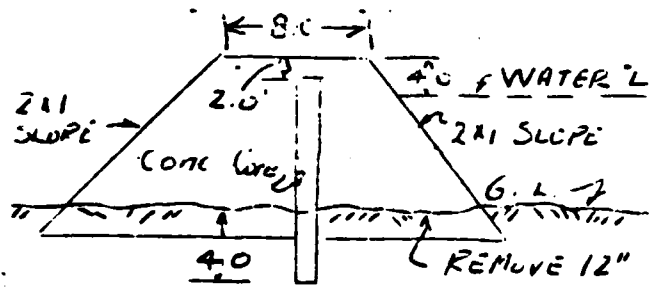

APPLICANTS DATA LOCATION SKETCH

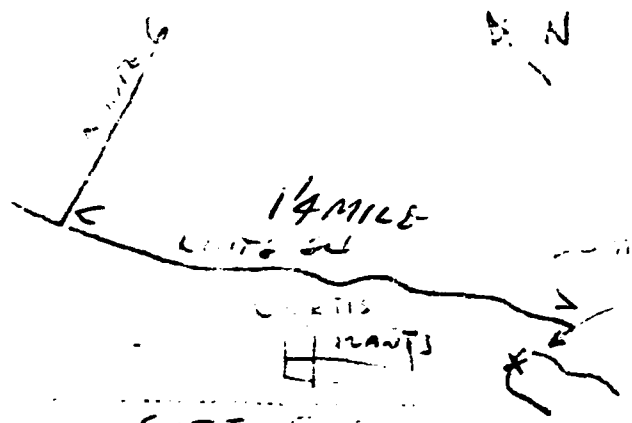

SITE PLAN



SPILLWAY SECTION

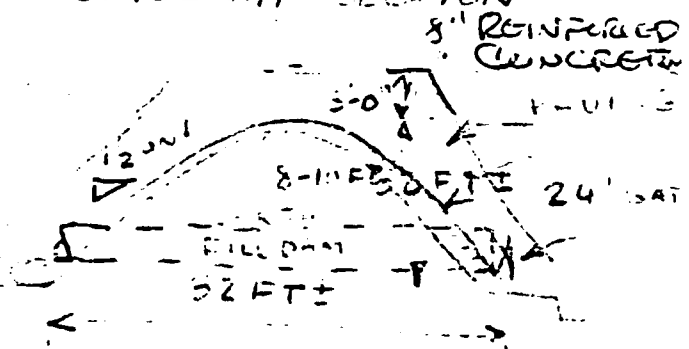

DIKE SECTION

EXISTING

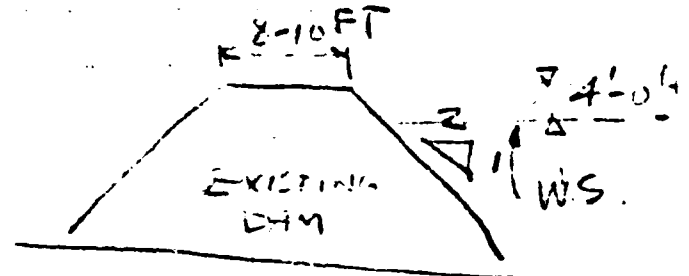

ALL DIMENSIONS SHOWN ARE APPROXIMATE

100-4-100 sent to Mr. Dean Clark 5-16-56
STATE BOARD OF SUPERVISION OF DAMS

RECEIVED
MAY 17 1956
STATE BOARD OF SUPERVISION OF DAMS

APPLICATION FOR CONSTRUCTION PERMIT
As required under Section 4731 of General Statutes

THIS APPLICATION TO BE SUBMITTED IN TRIPPLICATE

Owner S. CURTIS & SON, INC.

Date 5/10/56

P. O. Address SANDY HOOK,
NEWTOWN, CONN.

Tel. No. Garden 6-4421

Location of Structure:

Town SANDY HOOK

Shown on USGS Quadrangle NEWTOWN

Name of Stream CURTIS POND

at 1 inches south of Lat. 41°25'00"
north
abd 3 inches east of Long. 73°17'30"
west

Directions for reaching site from nearest village or route intersection:
(See sketch on reverse side)

TRAVEL EAST ON ROUTE 34 FROM INT-SECTION OF RT #6
ABOUT 1/4 MILES - ON RIGHT HAND SIDE

This is an application for: REPAIR OF SPILLWAY
(New Construction) (Alteration) (Repair) (Removal)
(describe project)

This pond is to be used for: FIRE PROTECTION - FACTORY WATER

Dimensions of pond: width 200 FT length 1300 FT area 7 ACRES.

Depth of water below spillway level: 8-10 FT (AVERAGE DEPTH 4-5 FT)

Total length of dam: ABOUT 150 FT

Length of spillway: 25 FT

Height of abutments above spillway: 2-4'

Type of spillway construction: CONCRETE SADDLE

Type of dyke construction: EARTH FILL EXISTING

Character of soil in river bed at spillway location: SANDY

Remarks: THIS IS A REPAIR TO A DAM SPILLWAY WASHED
OUT DURING THE NOV. FLOOD

Note: Show details of construction on reverse side.

Signed James C. Warner, P.E.

Nelson G. Curtis, Pres.
S. Curtis & Son Inc.

SAMPLE DATA
LOCATION SKETCH

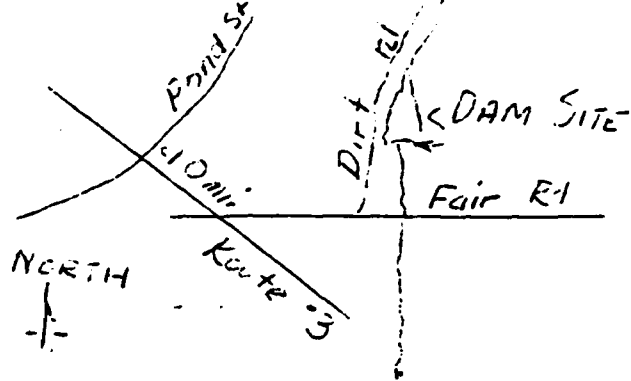

SITE PLAN

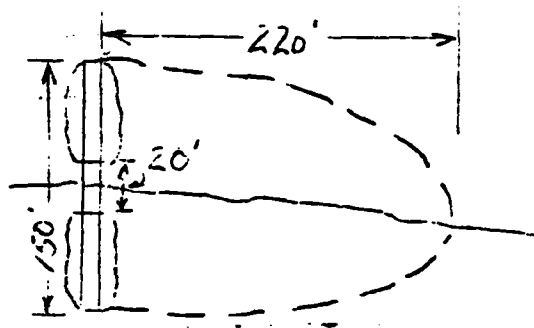

SPILLWAY SECTION

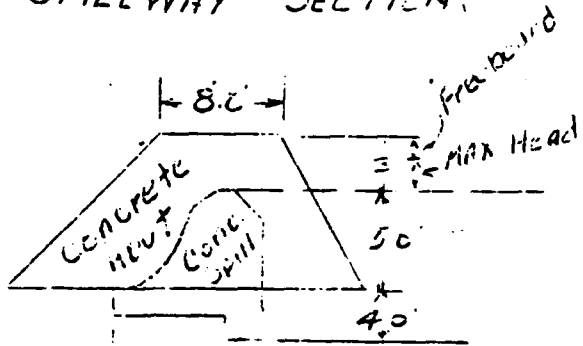

NOTE - IF THERE ARE TWO METHODS OF DISCHARGE SHOW BOTH

DIKE SECTION

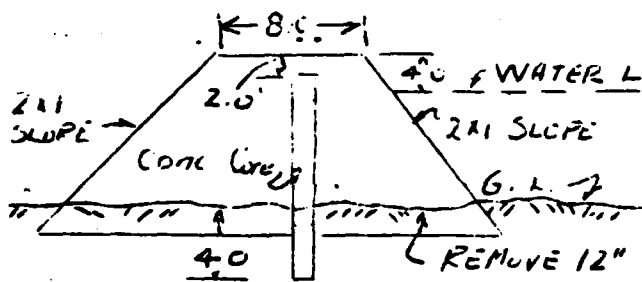

APPLICANTS DATA
LOCATION SKETCH

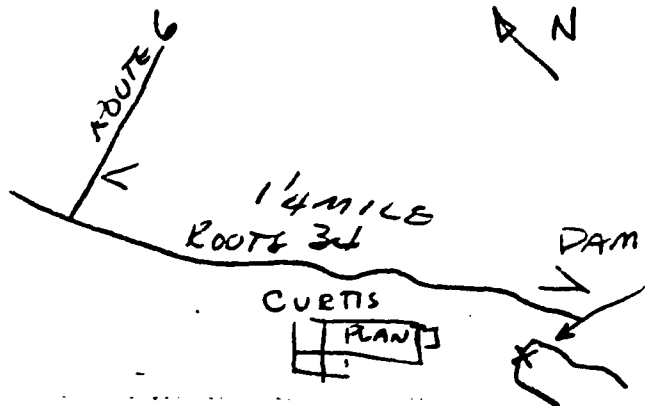

SITE PLAN

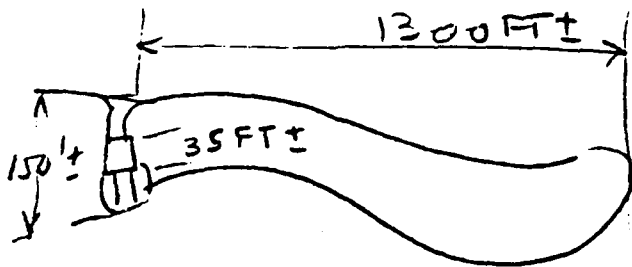

SPILLWAY SECTION

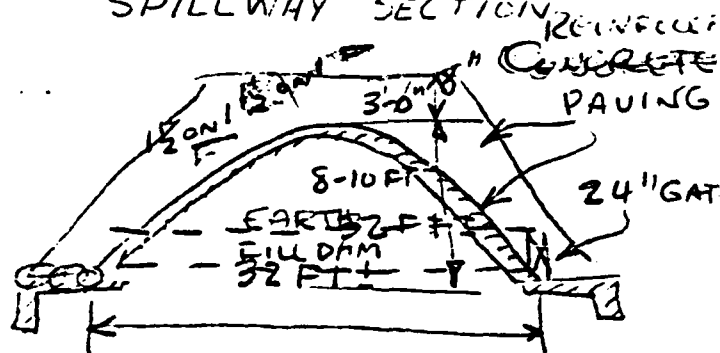

DIKE SECTION
EXISTING

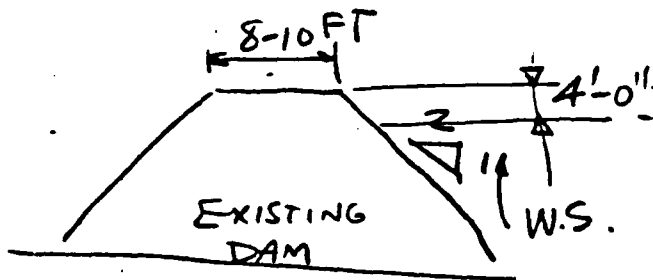

ALL DIMENSIONS SHOWN ARE

CURTIS DAM - SAVY HOOD

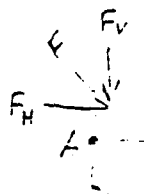

$$F_1 = 3 \times 30.5 \times 13 = 5440 \text{ lb} \checkmark$$

$$F_2 = \frac{50.5 \times 13 \times 13}{2} = 5270 \text{ lb} \checkmark$$

$$F_3 = 20 \times 13 \times 100 = 26000 \text{ lb} \checkmark$$

$$F_4 = \frac{50.5 \times 13 \times 13}{2} = 5270 \text{ lb} \checkmark$$

$$F_5 = 5 \times 10.5 \times 8 = 1500 \text{ lb} \checkmark$$

$$F_6 = 13 \times 10.5 \times 3 = 3550 \text{ lb} \checkmark$$

$$F_7 = \frac{1}{2} \times 10.5 \times 3 \times 3.05 = 302 \text{ lb} \checkmark$$

interchange
v =

$$\sum M_A = -2440 \times 6.5 - 5290 \times 4.33 + 5070 \times 6.7 + 5260 \times 3.6 - 1500 \times 4 - 302 \times 5.33 + 117 \times 9.06 + 250 \times 1.15 = 5697 \text{ ft}$$

$$x = -\frac{7916}{5697} = -1.39$$

W.S. of stability etc.

$$x = \frac{110}{200} = 1.55$$

$$\begin{array}{r} 306 \\ 541 \\ \hline 852.3 \end{array}$$

$$\begin{array}{l} \curvearrowright 3.62 \times 84.6\% + 6.7 \times 80.8\% + 1.085 \times 4.88\% \\ \quad 306 \qquad \qquad 541 \qquad \qquad 573 \end{array}$$

$$\begin{array}{l} \curvearrowleft 4 \times 24\% + 5.36 \times 52\% + 6.5 \times 39\% + 4.33 \times 8.42\% \\ \quad 96 \qquad \qquad 278 \qquad \qquad 254 \qquad \qquad 36.6 \end{array}$$

$$\begin{array}{r} 96 \\ 278 \\ 254 \\ 366 \\ \hline 974 \end{array}$$

$$\begin{array}{r} \checkmark 994\% \\ \curvearrowleft 852.3\% \\ \hline \checkmark 141.7\% \end{array}$$

$$\begin{array}{r} \downarrow 20.8\% \\ 84.6\% \\ \hline 1.88 \\ \downarrow 167.28 \\ \hline 76 \\ \downarrow 91.28\% \end{array} \qquad \begin{array}{r} \uparrow 34\% \\ 52 \\ \hline 76\% \end{array}$$

$$\frac{141.7}{91.28} = 1.55$$

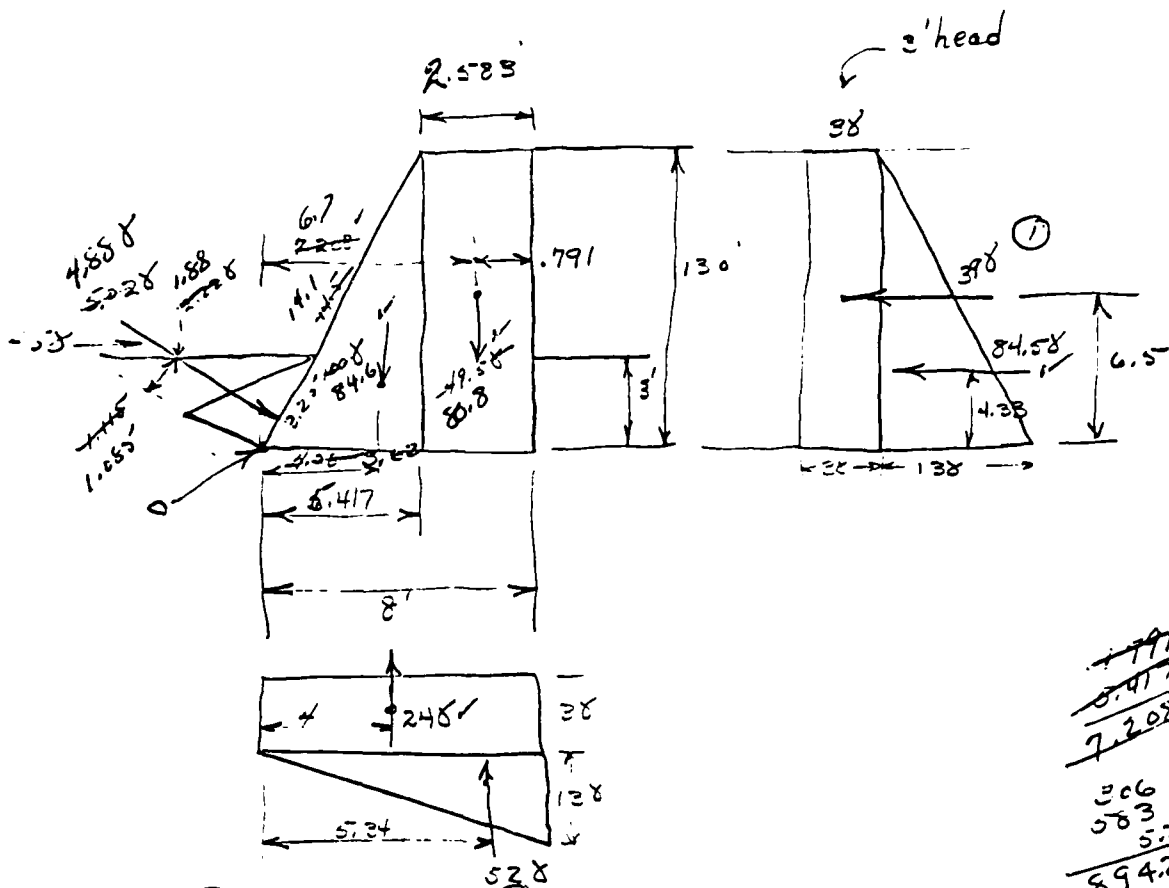

8.0
1.05
6.41
1.72
7.208

189
411.2
2110.2
14.5
169
29.3
198.3
141

~~1.11~~
8.417
7.208

306
583
5.29
894.29
1047.29
993.5
53.79

641.7
356.5
5.6
1003.8
993.5
1036.6
252.5
96
278
993.5

$$\sum M_o = \frac{3.62 \cdot 84.6}{2} + \frac{6.7 \cdot 80.8}{2} + \frac{1.085 \cdot 4.88}{2} + \frac{4.85 \cdot 1.053}{2}$$

$$= 1047.29 \gamma + 993.5 \gamma - 163 \gamma = -642 \gamma = -\frac{3360}{2360} \gamma$$

$$\sum V = \left(-\frac{1.88}{2} - \frac{84.6}{2} - \frac{80.5}{2} + 24 + 52 \right) \gamma = -76.72 \gamma = -\frac{6240}{76} \gamma$$

$$-642 = 4720 \gamma \quad \gamma = -0.136$$

149.5
2.72
151.72
76
75.72
1.58
84.6
80.5
166.98
76
90.98

CURTIS TANK - SANDY HILL

100-yr flood - 451 ac-ft.

100-yr flood

5.11

$$= (9.76 \times 10^{-10})^{3/2} = 273$$

5.11

$$= (9.76 \times 10^{-10})^{3/2} = 273$$

CURTIS FOND UHM.

Drainage Area = 1.4 sq. mi.

Main Chan Slope = 59 f/m

Tris " " = 129 f/m

Average Slope = 109 f/m

$C_B = 0.80$

MEAN ANNUAL FLOOD = $C_B A S = .80(1.4)(109) = 122.0$ cfs.

100 yr flood freq = $3.7 \times 122 = 451.4$ cfs.

AVERAGE SLOPE • 109 FT/MILE

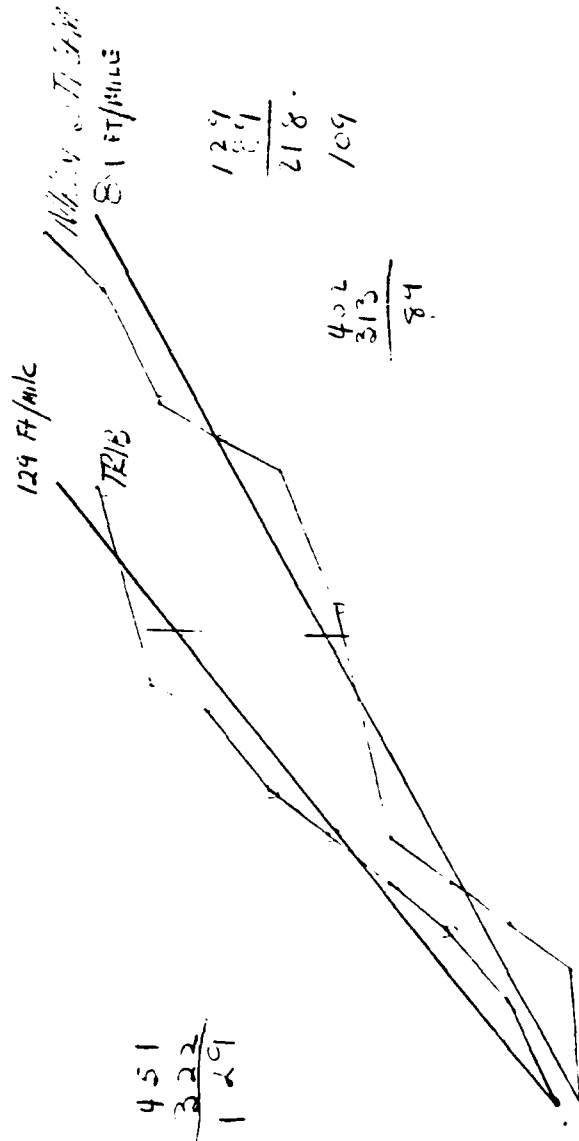

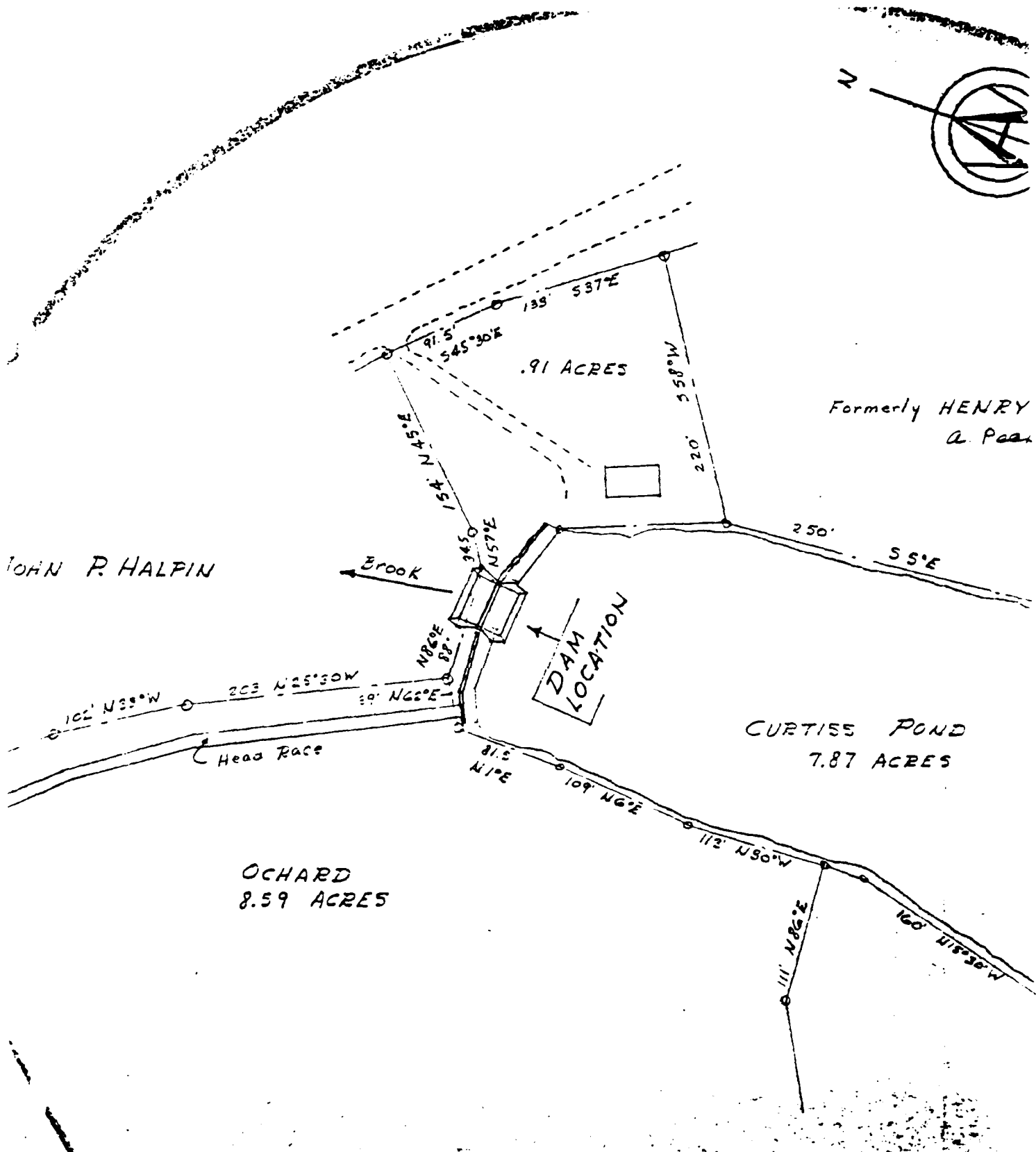
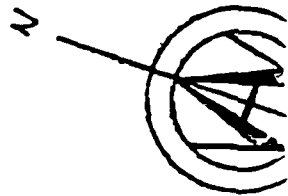

JOHN P. HALPIN

.91 ACRES

Formerly HENRY
A. Peck

DAM
LOCATION

CURTIS POND
7.87 ACRES

ORCHARD
8.59 ACRES

#5573 - DM 1

PLOT PLAN

1" = 100'

CURTIS POND BROOK



May 11, 1956
2 Sachem Road
Greenwich, Conn.

Mr. J. J. Curry, Chief Engineer
State Board for the Supervision of Dams
Room 317
State Office Building
Hartford 15, Conn.

Re: Curtis Dam

Dear Mr. Curry:

Enclosed for your file is a letter dated May 8, 1956 from Austin & Warner, Engineers, and their Blueprint dated April 16, showing details of proposed construction of the new dam to replace a very old one at Curtis Pond, Sandy Hook.

I have discussed these plans with Messrs. Curtis and Warner and requested comment on the details of the proposed concrete slab surfaces particularly as to possible movement.

I would appreciate your comment on this design.

Very truly yours,

DC:mmm

Dean Clark



AUSTIN and WARNER

Consulting Engineers

BRowning 2-5258

BRowning

2-5386

871 WEST MAIN STREET

P.O. BOX 295

WEST CHESHIRE, CONN.

May 8, 1956

Mr. Dean Clark
State Board for Dams, Dikes & Reservoirs
2 Sachem Road
Greenwich, Conn.

Curtis

Dear Mr. Clark:

As you requested, we are forwarding herewith 2 copies of our drawing 5523-DM1 showing the proposed Curtis Dam Reconstruction.

With regard to the matter of slab movement in the saddle type spillway, we will provide necessary joints, we discussed, in the construction so that the slab surfaces may readjust to conform without causing any serious displacement.

We look at this as an earth fill dam with a paved spillway sitting over it, just as if you put a saddle on a horse. This is a good deal less expensive than a gravity section spillway and we believe it is free of the problem of leakage underneath a gravity type dam.

We have used this idea of poured concrete paving on sloping surfaces as I mentioned at the Scovill plant several times with excellent success in the Power House pond and in the old canal.

We are going to use air entrained concrete to reduce any spalling tendency. The draw down gate will afford an opportunity to better control the water level in the pond during heavy rains.

We appreciate having had the opportunity to discuss this with you and trust this will meet with the Board's



AUSTIN and WARNER

Consulting Engineers

BRowning

BRowning 2-5258

2-5386

871 WEST MAIN STREET

P.O. BOX 295

WEST CHESHIRE, CONN.

Mr. Dean Clark
Page 2

approval.

I have written for a copy of Mr. Bigwood's paper on
runoff computations you spoke of.

Yours truly,

AUSTIN & WARNER

Louis A. Warner

LAW:baw

Registered Engineers in Connecticut, New York, Massachusetts, Wisconsin, New Hampshire, Maine and Rhode Island.

2 Sachem Road
Greenwich, Conn.
January 20, 1956

Mr. Nelson O. Curtis, President
S. Curtis & Company
Sandy Hook, Conn.

Dear Mr. Curtis:

The situation around your pond and dam as I saw it with you is briefly that the recent flood caused a complete failure of the dam forming Curtis Pond, washed out the bridge leading to your plant and caused further damage down stream.

You explained that the dam, consisting of large rocks laid up dry and an earth fill, has been in place for about 100 years and until a few years ago was used for power purposes. Since converting to other power the pond serves mainly for fire protection.

You further indicated that you believed it possible to secure water from the stream below the dam which when supplemented by additional storage tanks would satisfy your fire protection requirements without replacing the dam.

I understand that you are retaining, Austin & Warner, engineers, to study this problem. They will need the data I gave you from our Hartford office which is that the drainage area at the dam is 1.4 square miles and the average slope is 109 feet per mile, from which is determined the mean annual flow of 122 cubic feet per second and the 100 year frequency flood is computed to be 451 cfs.

I left with you copies of the Act and the regulations pertaining to dams which stipulate that dams shall be designed for not less than floods of 100 year frequency. From this your engineer will be able to estimate the cost of reconstruction. I shall be glad to know of your decision whether or not you will replace the dam and if so I will get in touch with you regarding further action.

Yours very truly,

Dean Clark
Member of the Board

DC:um

cc to Wills

1/20-10-20 - met with Curtis's name - plus files



STATE OF CONNECTICUT
BOARD OF FISHERIES AND GAME
2 WETHERSFIELD AVENUE • HARTFORD 15, CONNECTICUT

January 3, 1956

Nelson G. Curtis, President
S. Curtis and Son, Incorporated
Sandy Hook, Connecticut

Dear Sir:

Under Section 5001 of the General Statutes authorization is hereby granted for the construction of a dam on Curtis Brook tributary to the Pootatuck River on your property located in the town of Newtown, it being my understanding that the public interest in the stream will not be adversely affected by such a dam.

It will be necessary to have the project approved by the State Board of Supervision of Dams, whose address is Room 317, State Office Building, Hartford, Connecticut.

Very truly yours,

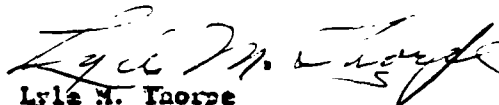
Lyle M. Thorpe
Director

LMT/la

cc: State Board of Supervision of Dams
District Supervisor Alfred J. Bunyadi
Soil Conservation Service, Danbury, Connecticut

RECEIVED
STATE WATER COMMISSION

COPY

REQUEST FOR INFORMATION ON JURISDICTION

Date 1/15/30

State Board of Supervision of Dams
317 State Office Building
Hartford 15, Connecticut

Gentlemen:

I propose to construct a _____
describe proposed structure

on Curtis Pond in the Town of _____
name of brook

The site may be reached from _____ by proceeding (north) (south)
(east) (west) on route # _____
(describe specifically means of reaching site)

The proposed construction will create a pond of _____ acres having a
maximum depth of _____ feet.

Would you please inform me as to whether such construction falls
within the jurisdiction of the Board of Supervision of Dams by reason that
it might endanger life or property.

Very truly yours,

1/17 - Curtis Pond - cancelled.
12/28 - Curtis Pond - cancelled.
cancelled.

Name _____
Address _____

The work is being assigned to:
Mr. Louis Warner
Austin and Warner
West Cheshire, Connecticut
Phone - Cheshire Browning 2-5258

Tel. No. Newtown, Garden 6-4421
Home - Garden 6-4032

December 13, 1955

Mr. Dean Clark
2 Sachem Road
Greenwich, Connecticut

Dear Mr. Clark:

Enclosed you will find a "Request for Information on Jurisdiction" form for the repair of Curtis Pond Dam from S. Curtis and Son, Inc., of Sandy Hook, Connecticut. The spillway section of the dam washed out during the October flood destroying two or three bridges downstream and also causing some other property damage. It is, therefore, felt that this dam comes under the jurisdiction of the Board.

The drainage area at the dam is 1.4 square miles. The average slope is 109 feet/mile. Using a C_p of 0.30, the mean annual flood and 100-year frequency flood were computed to be 122 cfs and 451 cfs respectively.

It is suggested that the "Notification of Jurisdiction" form together with three copies of the Application for Construction Permit be sent to the owner.

Very truly yours,

M. E. Hupfer
Senior Engineer

MEH/p

Encl.

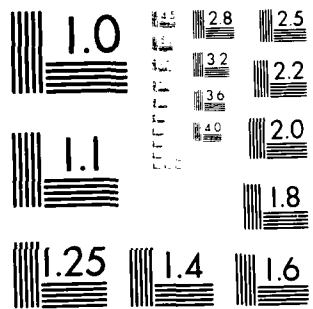

MICROCOPY RESOLUTION TEST CHART
NATIONAL BUREAU OF STANDARDS-1963-A

APPENDIX C

PHOTOGRAPHS

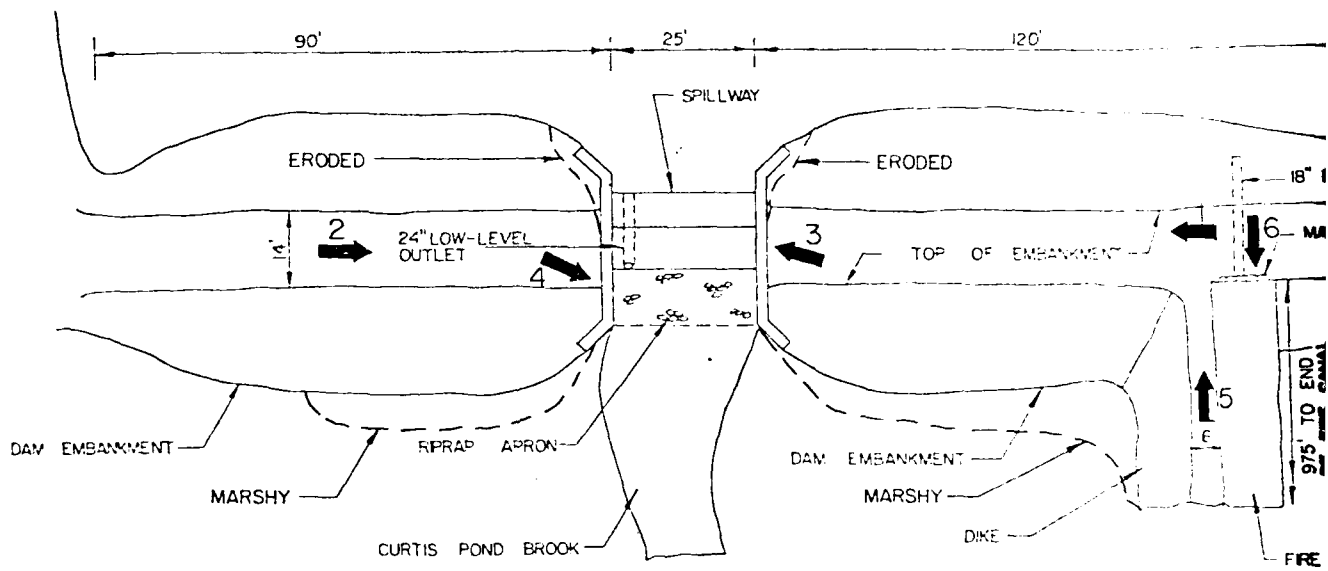

DAM EMBANKMENT PLAN



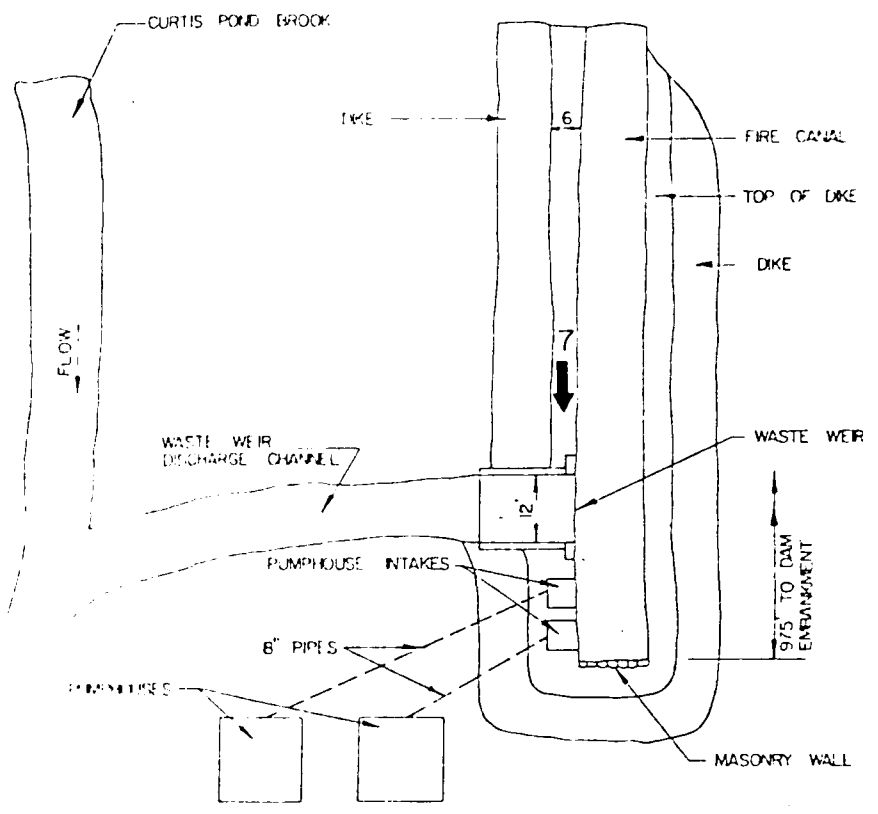
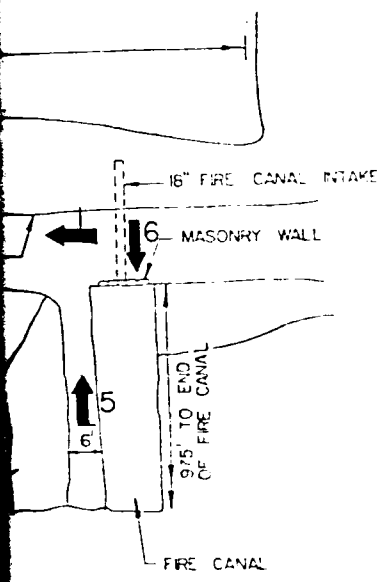

END OF FIRE CANAL PLAN
 SCALE 0 20' 40'

PHOTO LOCATION PLAN
 CURTIS POND DAM



Photo 1 Top and downstream slope of left embankment dam.



Photo 2 Top of embankment dam, spillway crest and spillway training walls.

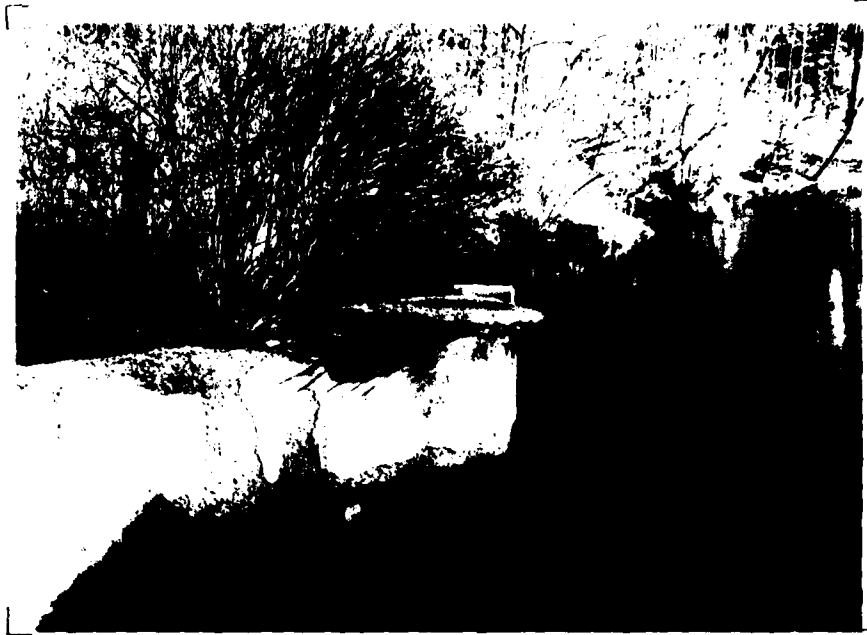

Photo 3 Remains of the low-level outlet gate control platform on the right spillway training wall.



Photo 4 Spillway rock apron and outlet channel.



Photo 5 Top of embankment dam, canal dike, canal intake, and Curtis Pond.



Photo 6 Downstream area of fire canal and canal dike.



Photo 7 End of canal, waste weir, pumphouse intakes,
pumphouses (right), and S. Curtis and Sons, Inc.
factory in background.

APPENDIX D

HYDROLOGIC AND HYDRAULIC COMPUTATIONS

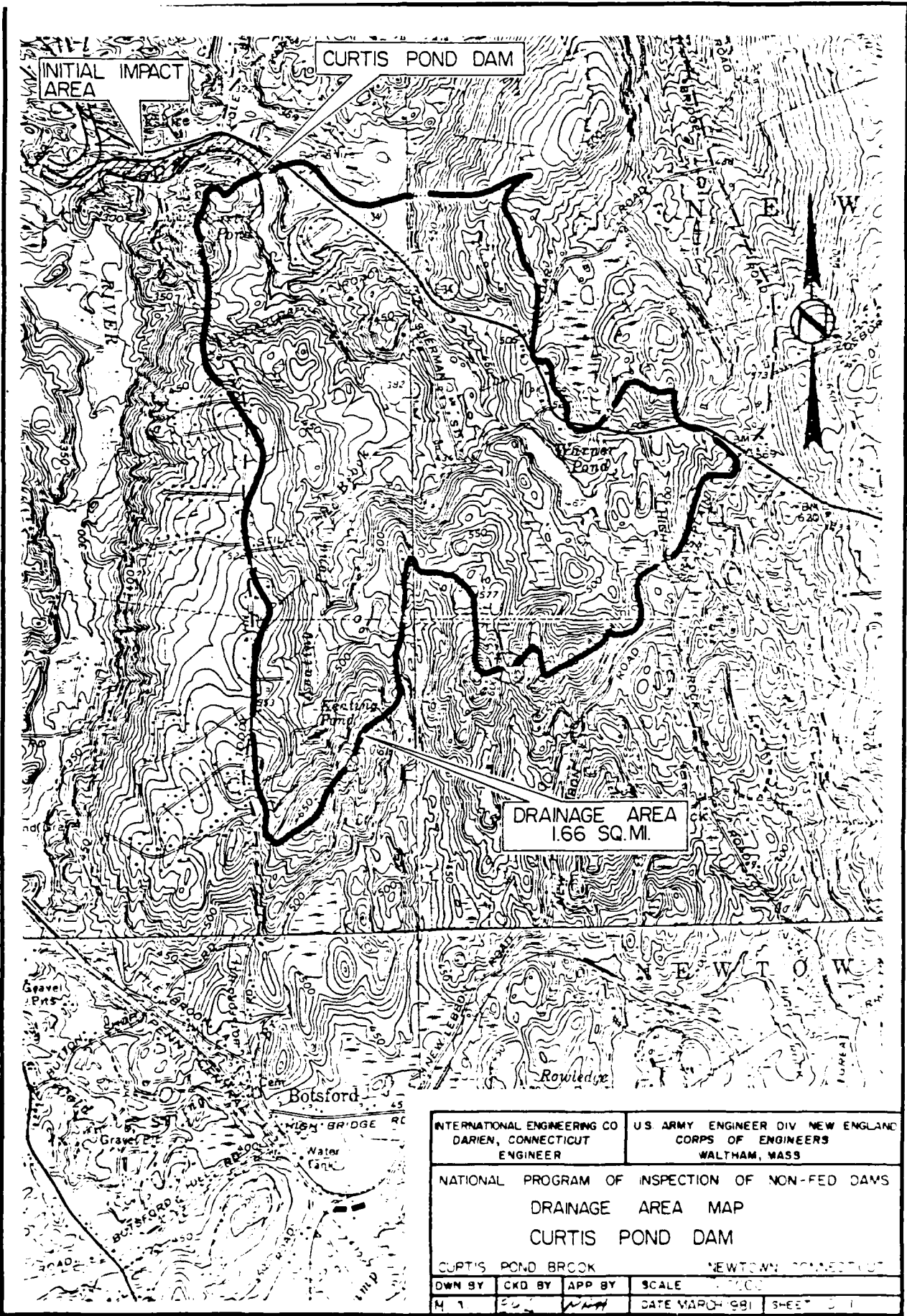

INTERNATIONAL ENGINEERING CO DARIEN, CONNECTICUT ENGINEER		US ARMY ENGINEER DIV NEW ENGLAND CORPS OF ENGINEERS WALTHAM, MASS	
NATIONAL PROGRAM OF INSPECTION OF NON-FED DAMS			
DRAINAGE AREA MAP			
CURTIS POND DAM			
CURTIS POND BROOK		NEWTON, CONNECTICUT	
OWN BY	CKD BY	APP BY	SCALE
M 1	ES	MM	DATE MARCH 1981 SHEET 5 1

INTERNATIONAL ENGINEERING COMPANY, INC.
 Project NATIONAL DAM INSPECTION PROGRAM (NDIP) Contract No. 2616-25 Sheet D-1
 Feature CURTIS POND DAM Designed MP File No. _____
 Item _____ Checked FR B Date 1/5/81
 Date 1/25/81

HYDRAULIC / HYDROLOGIC INSPECTION

CURTIS POND DAM, NEWTOWN, CT

I. PERFORMANCE AT PEAK FLOOD CONDITIONS

1. MAXIMUM PROBABLE FLOOD

a. WATERSHED CLASSIFIED AS "ROLLING"

b. WATERSHED AREA (D.A.) = 1.66 sq. mi.*

* NOTE: DRAINAGE AREA FROM IECO MEASUREMENTS ON THE NEWTOWN U.S.G.S QUADRANGLE MAP, CT AND U.S. CORPS OF ENGINEERS DATA.

c. EXTRAPOLATING FROM NED-ACE GUIDE CURVES

$$PMF \approx 2175 \text{ CFS/sq mi.}$$

d. THEREFORE, PEAK INFLOW:

$$PMF = 2175 \times 1.66 \approx 3610 \text{ CFS}$$

$$\frac{1}{2} PMF = 1805 \text{ CFS}$$

2. SURCHARGE AT PEAK INFLOWS (PMF AND $\frac{1}{2}$ PMF)

2. OUTFLOW RATING CURVE

i. SPILLWAY:

CURTIS POND DAM HAS A CONCRETE SPILLWAY IN THE MIDDLE OF OF THE EMBANKMENT. THE SPILLWAY (SEE SKETCH BELOW) IS A BROAD-CRESTED WEIR WITH A VERTICAL UPSTREAM FACE AND



Project NDIP
 Feature CURTIS POND DAM
 Item _____

Contract No. 2616-05 File No. _____
 Designed MP Date 11/6/81
 Checked EP g Date 11/20/81

A DOWNSTREAM FACE INCLINED AT 0.8^H TO 1^V. THE CREST OF THE SPILLWAY SLOPES DOWN TO THE VERTICAL UPSTREAM FACE AT AN INCLINATION OF 6^H TO 1^V. THE DOWNSTREAM EDGE OF THE CREST IS ROUNDED TO RADIUS OF 1 FT. AT ELEV. 327. THE SPILLWAY IS 25-FT-LONG AND THE CREST IS 4 FT. BELOW THE TOP OF THE DAM (DATA FROM IECO FIELD MEASUREMENTS AND DAM RECONSTRUCTION DRAWING IN 1956).

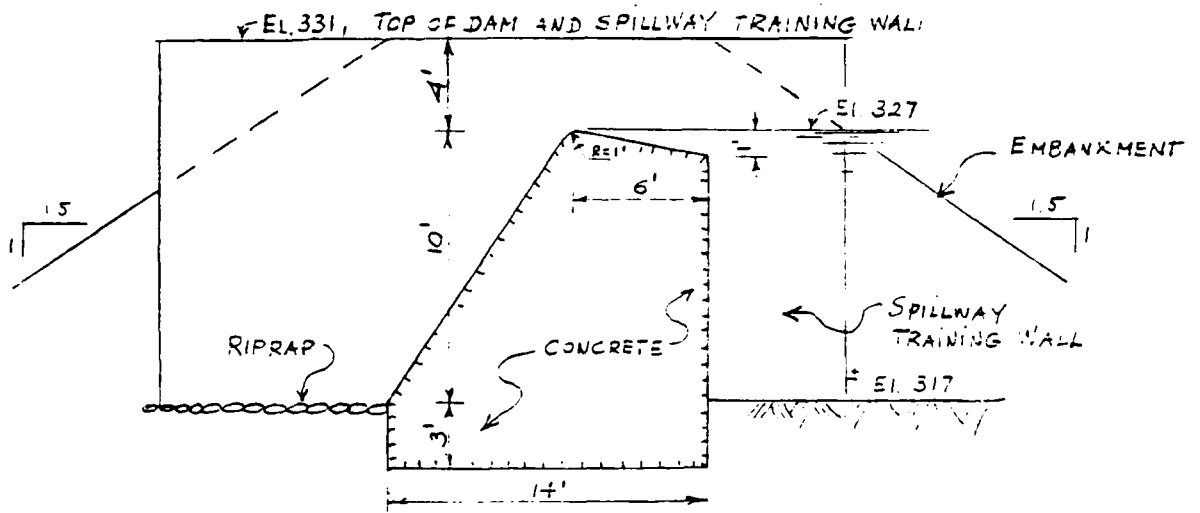

ASSUMING $C = 3.1$ FOR THE SPILLWAY (SEE BRATER AND KING, p. 5-11)

DISCHARGE IS APPROXIMATED BY:

$$Q_s = C L H^{3/2} = 3.1 \times 25 \times H^{3/2} = 77.5 H^{3/2}$$

- ii. EXTENSION OF THE RATING CURVE FOR SURCHARGE OVERTOPPING THE DAM AND/OR ADJACENT TERRAIN

THE CURTIS POND DAM IS AN EARTH-FILL EMBANKMENT WITH A TOTAL ELEVATION OF 331 AND TOTAL LENGTH OF 250 FT. THE TERRAIN



Project

NDIPContract No. 2616-05

File No. _____

Feature

CURTIS POND DAMDesigned msDate 11/6/54

Item _____

Checked EP byDate 11/20/54

ADJACENT TO THE RIGHT SIDE OF THE DAM HAS A SLOPE OF $\pm 10:1$ FOR APPROXIMATELY 50 FEET AND THEN THE SLOPE CHANGES TO $\pm 2:1$. THE TERRAIN ADJACENT TO THE LEFT SIDE OF DAM HAS A SLOPE OF $\pm 1.5:1$ (SEE SKETCH 4 BELOW).

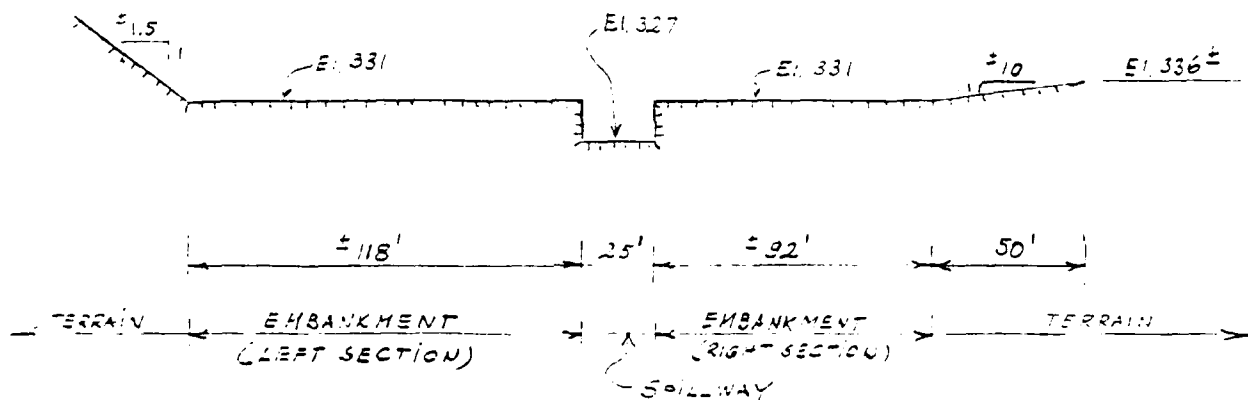

DUE TO THE IRREGULARITIES IN THE PROFILE AN EQUIVALENT WEIR LENGTH MUST BE COMPUTED ASSUMING A DISCHARGE COEFFICIENT $C=2.7$ AND ADOPTING THE SPILLWAY CREST AS DATUM (EL. 327), THE OVERFLOW CAN BE APPROXIMATED BY THE FOLLOWING EQUATIONS:

- (1) SLOPING TERRAIN TO THE RIGHT OF THE DAM TO EL. 336 = :

$$L_{RS} = \frac{2}{5} Z_{R1} (H-4) = \frac{2}{5} \times 10 (H-4), H < 9 \text{ FT.} \therefore Q_{RS} = 2.7 \times 4 \times (H-4)^{\frac{5}{2}} = 29.7 (H-4)^{\frac{5}{2}}$$

INTERNATIONAL ENGINEERING COMPANY, INC.
 Project NDIP
 Feature CURTIS POND DAM
 Item _____

Sheet D-4
 Contract No. 555-05
 Designed M.P.
 Checked F.P.
 File No. _____
 Date 1/6/81
 Date 1/20/81

(2) TOP OF DAM AT EL 331 :

$$Q'_3 = 2.7 \times 210 \times (H-4)^{3/2} = 567 (H-4)^{3/2}$$

(3) SLOPING TERRAIN TO THE LEFT OF THE DAM :

$$L_{L3} = 2/5 \times 1.5 (H-4) \quad \therefore Q'_{L3} = 2.7 \times 0.6 \times (H-4)^{5/2} \approx 1.6 (H-4)^{5/2}$$

THEREFORE, THE TOTAL OUTFLOW RATING CURVE IS APPROXIMATED BY :

$$Q = 77.5 H^{3/2} + 567 (H-4)^{3/2} + 1.6 (H-4)^{5/2}, \quad H < 9 \text{ FT}$$

THE RESULTING OUTFLOW RATING CURVE IS AS FOLLOWS :

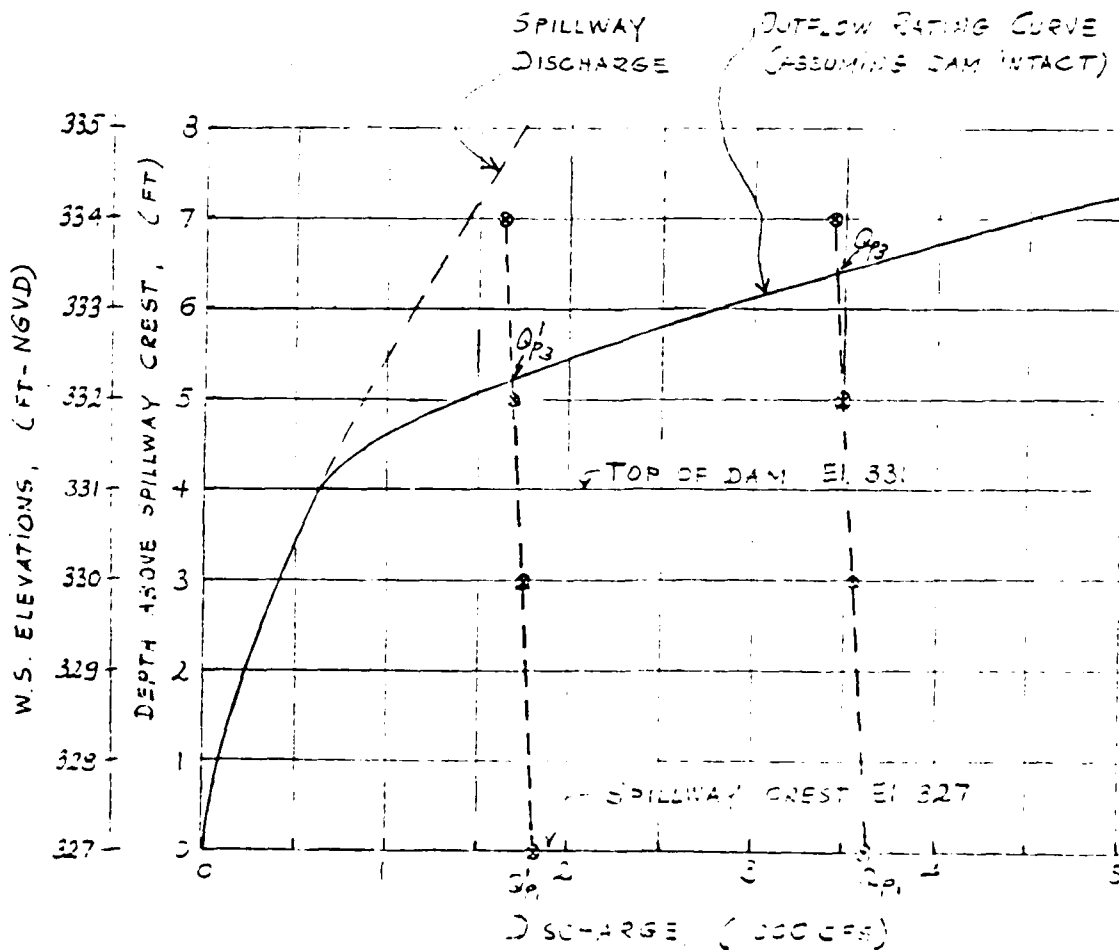

INTERNATIONAL ENGINEERING COMPANY, INC.
 Project "DIP"
 Feature CURTIS POND DAM
 Item _____

Sheet D-5
 Contract No. 2616-05 File No. _____
 Designed 710 Date 1/6/81
 Checked EB g. Date 1/20/81

b. SURCHARGE HEIGHT TO PASS PEAK INFLOWS (Q_p AND Q_p')

i. @ $Q_p = PMF = 3610 \text{ CFS}$, $H_s \approx 6.5 \text{ FT}$

ii. @ $Q_p' = 1/2 PMF = 1805 \text{ CFS}$, $H_s' \approx 5.3 \text{ FT}$

c. EFFECT OF SURCHARGE STORAGE ON PEAK OUTFLOWS

i. AVERAGE POND AREA WITH V EXPECTED SURCHARGE:

(1) POND AREA AT FLOW LINE (EL. 327 NGVD):* $A_w = 7.87 \text{ AC}$

(2) AREA AT CONTOUR 330 NGVD:** $A_{330} \approx 11.33 \text{ AC}$

(3) AREA AT CONTOUR 340 NGVD:** $A_{340} \approx 21.2 \text{ AC}$

\therefore AREA AT EL. 334 (MAX. EXPECTED SURCHARGE): $A_{334} \approx 15.64 \text{ AC}$

THE SURCHARGE VOLUME IS APPROXIMATED USING THE FOLLOWING EQUATION: $V = 7.87x + \frac{x^2(13.33)}{13(2)}$; $0 \leq x \leq 13$

* FROM DAM RECONSTRUCTION DRAWING #5523-DM1, 1956

** FROM USGS NEWTOWN QUADRANGLE MAP, CONN.

ii. ASSUME NORMAL POOL AT SPILLWAY CREST EL. 327.

iii. DISCHARGE (Q_o) AT VARIOUS HYPOTHETICAL SURCHARGE ELEVATIONS

$H = 7 \text{ FT}$, $V = 84 \text{ AC-FT}$ $\therefore S = \frac{84}{1.66 \times 53.3} = 0.95''$

$H = 5 \text{ FT}$, $V = 54 \text{ AC-FT}$ $\therefore S = 0.61''$

$H = 3 \text{ FT}$, $V = 30 \text{ AC-FT}$ $\therefore S = 0.34''$



Project VDIP
 Feature CURTIS POND DAM
 Item _____

Contract No. 2616-05 Sheet 2-5
 Designed M.P. File No. _____
 Checked E.B. J. Date 11/16/21
 Date 1/20/21

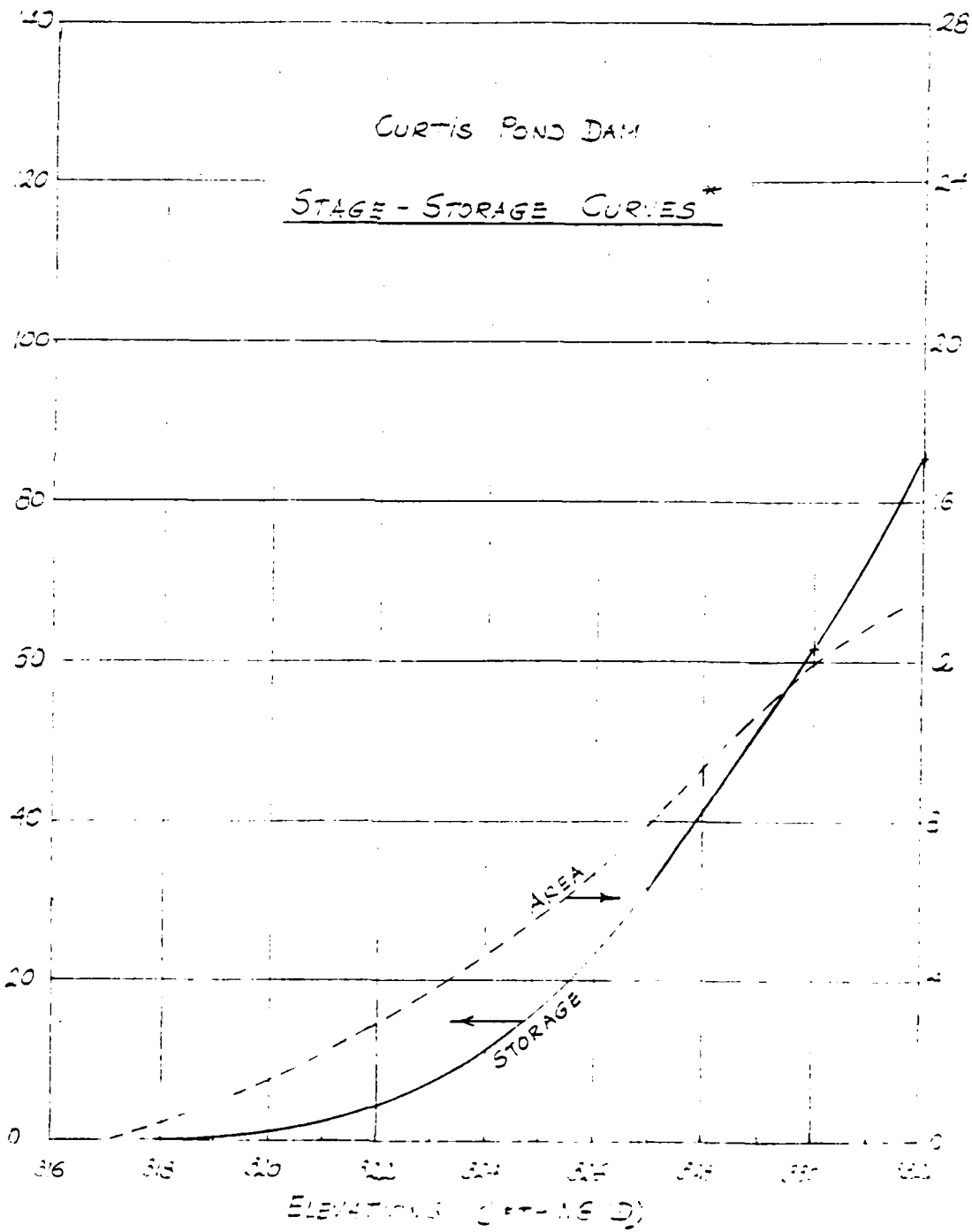

* FROM DAM RECONSTRUCTION DRAWING No. 5523-DVI, 1967 AND
 1965 VENTURA QUADRANGLE MAP COPY.



Project NDIP
 Feature GURTIS POND DAM
 Item _____

Contract No. 2616-05 File No. _____
 Designed MP Date 11/5/51
 Checked ER B. Date 1/20/51

FROM APPROXIMATE ROUTING NED-ACE GUIDELINES AND 19 IN. MAXIMUM PROBABLE RUNOFF IN NEW ENGLAND:

$$Q_{P_2} = Q_{P_1} \left(1 - \frac{S}{19}\right) \quad \text{AND FOR } 1/2 \text{ PMF: } Q_{P_2}^1 = Q_{P_1}^1 \left(1 - \frac{S}{3.5}\right)$$

∴ FOR THE PREVIOUS HYPOTHETICAL SURCHARGES:

$$H = 7 \text{ FT; } \quad Q_{P_2} = 3430 \text{ CFS; } \quad Q_{P_2}^1 = 1625 \text{ CFS}$$

$$H = 5 \text{ FT; } \quad Q_{P_2} = 3434 \text{ CFS; } \quad Q_{P_2}^1 = 1689 \text{ CFS}$$

$$H = 3 \text{ FT; } \quad Q_{P_2} = 3545 \text{ CFS; } \quad Q_{P_2}^1 = 1740 \text{ CFS}$$

d. PEAK OUTFLOWS (Q_{P_3} AND $Q_{P_3}^1$)

USING NED-ACE GUIDELINES "SURCHARGE STORAGE ROUTING"

ALTERNATE METHOD AND RATING CURVE (SEE P. D-4):

$$Q_{P_3} = 3450 \text{ CFS} \quad H_3 = 6.3 \text{ FT}$$

$$Q_{P_3}^1 = 1670 \text{ CFS} \quad H_3^1 = 5.2 \text{ FT}$$

Project N.D.P.
Feature CURTIS POND DAM
Item _____Contract No. 2414-25 File No. _____
Designed TMP Date 1/6/81
Checked ER 12 Date 1/20/81

3. SPILLWAY CAPACITY RATIO TO PEAK INFLOWS AND OUTFLOWS:

a. SPILLWAY CAPACITY TO TOP OF DAM (E.I. 331):

$$H = 4 \text{ FT}; \quad Q_s = 620 \text{ CFS}$$

∴ THE TOTAL SPILLWAY CAPACITY TO TOP OF DAM IS $(\pm) 17\%$ OF THE INFLOW (Q_{P_1}) AND $(\pm) 18\%$ OF THE OUTFLOW (Q_{P_3}) AT PEAK FLOOD = PMF. LIKEWISE, THE TOTAL SPILLWAY CAPACITY TO TOP OF DAM IS $(\pm) 34\%$ OF THE INFLOW (Q_{P_1}') AND $(\pm) 37\%$ OF THE OUTFLOW (Q_{P_3}') AT PEAK FLOOD = $1/2$ PMF.

b. SPILLWAY CAPACITY TO PMF AND $1/2$ PMF SURCHARGES:

i. CAPACITY TO PMF SURCHARGE

$$H = 6.3 \text{ FT}; \quad Q_s = 1230 \text{ CFS.}$$

∴ THE TOTAL SPILLWAY CAPACITY TO PMF SURCHARGE IS $(\pm) 34\%$ OF THE INFLOW (Q_{P_1}) AND $(\pm) 36\%$ OF THE OUTFLOW (Q_{P_3}) AT PEAK FLOOD = PMF.

ii. CAPACITY TO $1/2$ PMF SURCHARGE

$$H = 5.2 \text{ FT}; \quad Q_s = 920 \text{ CFS}$$

∴ THE TOTAL SPILLWAY CAPACITY TO $1/2$ PMF SURCHARGE IS $(\pm) 5\%$ OF THE INFLOW (Q_{P_1}') AND $(\pm) 55\%$ OF THE OUTFLOW (Q_{P_3}') AT PEAK FLOOD = $1/2$ PMF.



Project NDIP Contract No. 2616-05 Sheet 17-3
Feature CURTIS POND DAM File No. _____
Item _____ Designed MP Date 1/6/81
Checked FR B Date 1/20/81

NOTE: THE CURTIS POND DAM HAS 24 IN DIAM AND ^(±) 14-FT-LONG VALVED OUTLET WITH INVERT EI ^(±) 317.0. THE OUTLET IS LOCATED AT THE RIGHT SIDE OF THE SPILLWAY. THE OUTLET CAPACITY UNDER A HEAD OF ^(±) 10 FT (SPILLWAY CREST EI 327) IS ESTIMATED AT ^(±) 48 CFS AND UNDER A HEAD OF ^(±) 4 FT (TOP OF DAM EI 331) IT IS ^(±) 57 CFS. CURRENTLY, THIS OUTLET IS INOPERABLE. THE INVERT ELEVATION OF THE 18 INCH UNGATED INTAKE FOR THE FIRE CANAL IS NOT KNOWN AND ALSO APPEARED INOPERABLE. THE CAPACITY OF THESE OUTLETS ARE NOT CONSIDERED USEFUL IN EMERGENCIES TO LOWER THE RESERVOIR LEVEL AND ARE NOT INCLUDED IN THE PREVIOUS OUTFLOW RATING CURVE.



Project NDIP
 Feature CURTIS POND DAM
 Item _____

Sheet D-10
 File No. _____
 Contract No. 2216-05
 Designed MP
 Checked ER W
 Date 1/6/81
 Date 1/20/91

II. DOWNSTREAM FAILURE HAZARD

I. POTENTIAL IMPACT AREA

F. HOUSES LOCATED ALONG CURTIS POND BROOK IN THE SOUTH-EASTERN PORTION OF THE TOWN OF BERKSHIRE, APPROXIMATELY 500 FT TO 1000 FT DOWNSTREAM OF THE DAM, NEAR BERKSHIRE ROAD, ARE WITHIN THE IMPACT AREA. THE FIRST FLOOR ELEVATIONS OF THESE HOMES RANGE FROM 8[±] FT TO 12[±] FT ABOVE THE STREAMBED. CONSEQUENTLY, THE STRUCTURES ARE CONSIDERED POTENTIAL DOWNSTREAM HAZARDS

2. FAILURE AT CURTIS POND DAM.

a. BREACH WIDTH

i. HEIGHT OF DAM:

TOP OF DAM EL. 331; DAM DOWNSTREAM TOE EL. 317[±]; ∴ H = 14 FT

ii. DAM MID-HEIGHT EL. 324 (331 - 14/2 = 324)

iii. APPROXIMATE MID-HEIGHT LENGTH OF BREACH (FROM ESCO DRAWINGS)

iv. BREACH WIDTH (SEE VED-AGE DOWNSTREAM FAILURE SCENARIOS)

$$W_b = .25L = 0.25 \cdot 190 = 48 \text{ FT}$$

b. PEAK FAILURE OUTFLOW (Q_F)

ASSUME DISCHARGE AT TOP OF DAM (EL. 331) AND CHANNEL NOT

INCLUDED IN THE BREACH.

Project NDIP
 Feature CURTIS POND DAM
 Item _____

Sheet 2-11
 Contract No. 2612-05 File No. _____
 Designed MP Date 11/6/81
 Checked ER Date 1/20/81

i. HEIGHT AT TIME OF FAILURE : $Y_0 = 14$ FT

ii. SPILLWAY DISCHARGE AT TIME OF FAILURE : $Q_s = 620$ CFS

iii. BREACH OUTFLOW (Q_b) :

$$Q_b = 9/27 W_b \sqrt{g} Y_0^{3/2} = 9/27 \times 76 \times \sqrt{32.2} \times 14^{3/2} \approx 4230 \text{ CFS}$$

iv. PEAK FAILURE OUTFLOW (Q_p) TO CURTIS POND BROOK :

$$Q_p = Q_s + Q_b = 620 + 4230 = 4850 \text{ CFS}$$

c. FLOOD DEPTH IMMEDIATELY DOWNSTREAM FROM DAM :

$$Y = 0.44 Y_0 = 0.44 \times 14 \approx 6.2 \text{ FT}$$

d. ESTIMATE OF DOWNSTREAM FAILURE CONDITIONS AT 1ST DOWNSTREAM

HOUSE (SEE NED-ACE GUIDELINES FOR ESTIMATING DIS FAILURE HYDROGRAPHS)

i. REACH OF CURTIS POND BROOK BETWEEN DAM AND IMPACT AREA

THE 300[±]-FT-LONG REACH OF CURTIS POND BROOK FROM THE CURTIS POND DAM TO THE INITIAL IMPACT AREA, NEAR BERKSHIRE ROAD, IS APPROXIMATELY SHAPED AS SHOWN ON THE SKETCH BELOW:

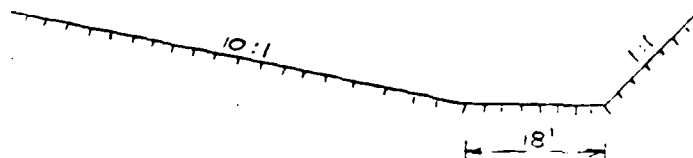

THE AVERAGE SLOPE OF THE REACH IS $\approx 0.5\%$

ii. CURTIS POND DAM RESERVOIR STORAGE AT TIME OF FAILURE :

NO ACTUAL STORAGE DATA OTHER THAN THE ACE-US INVENTORY OF DAMS, DATED 1/24/79, IS AVAILABLE TO ASCERTAIN THE STORAGE CAPACITY OF THIS DAM. USING THE APPROXIMATE FORMULA:

$$S = 0.5 A_0 \bar{H} + \bar{A} H \quad (A_0 = \text{POND AREA AT SPILLWAY CREST EL. 327,}$$

ASSUME $A_0 = 7.87 \text{ AC}$; \bar{H} = AVERAGE DEPTH OF POND BELOW

SPILLWAY CREST, ASSUME $\bar{H} = 8 \text{ FT}$; \bar{A} = AVERAGE POND SURCHARGE AREA

ASSUME $\bar{A} = 12 \text{ AC}$; $H = 1 \text{ FT}$, SURCHARGE HEIGHT), THE STORAGE

IS $80 \pm \text{ AC-FT}$.

THEREFORE, ASSUME $S_{MAX} \approx 80 \text{ AC-FT}$ ($\frac{S_{MAX}}{2} \approx 40 \text{ AC-FT}$)

* THE ACE-US INVENTORY OF DAMS GIVES: $S_{MAX} = 50 \text{ AC-FT}$; $S_{NORM} = 26 \text{ AC-FT}$

iii. PEAK INFLOW TO REACH: $Q_{P1} = 7320 \text{ CFS}$

iv. APPROXIMATE STAGE AT POTENTIAL IMPACT AREA FAILURE OF CURTIS POND DAM (8'-HIGH)

REACH $L = 500 \text{ FT}$; $n = 0.05$; $S = 0.005$, STAGE-DISCHARGE CURVES ARE IN FIG.

PREFAILURE DISCHARGE $Q = 620 \text{ CFS}$, $Y = 4 \text{ FT}$ $A = 160 \text{ FT}^2$

i. PREFAILURE STORAGE $V = L \times A = 500 \times 160 = 1.6 \times 10^5 \text{ AC-FT}$

FAILURE DISCHARGE $Q_{P1} = 4850 \text{ CFS}$, TRY $Y_1 = 14 \text{ FT}$; $A_1 = 1330 \text{ FT}^2$

ii. FAILURE STORAGE $V_1 = L \times A_1 = 500 \times 1330 = 1.527 \times 10^5 \text{ AC-FT}$ OR

$V_1 = V_1 - V = 1.527 \times 10^5 - 1.6 \times 10^5 = 13.43 \text{ AC-FT} < \frac{1}{2} S_{MAX} = 40 \text{ AC-FT}$ OK



Project NOEP
 Feature CURTIS POND DAM
 Item _____

Contract No. 325-05
 Designed MP
 Checked EE By By

Sheet D-2
 File No. _____
 Date 16/21
 Date 20/21

STAGE - DISCHARGE RATIO CURVES

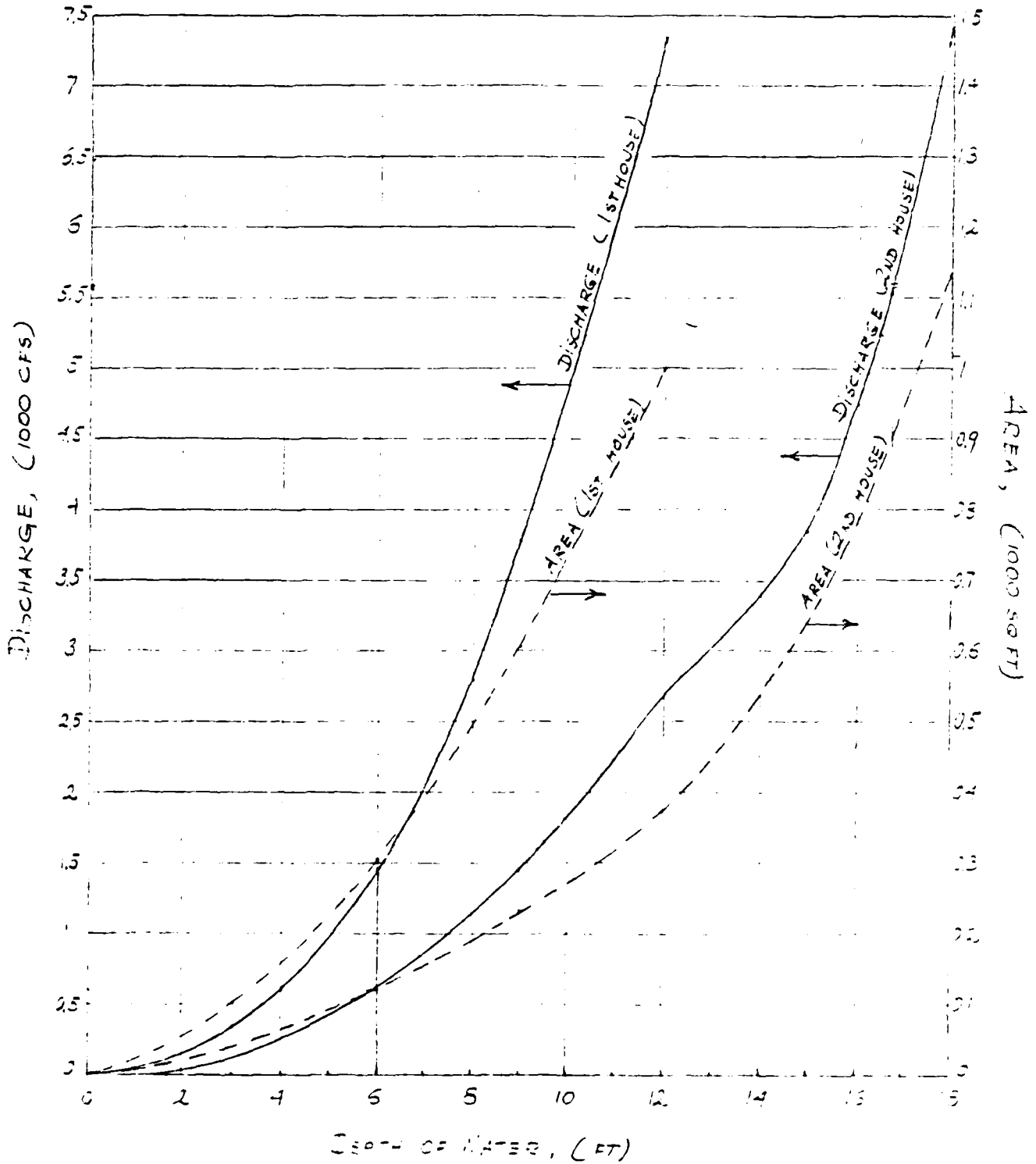

Project MOJO
 Feature CURTIS POND DAM
 Item _____

Sheet 0-1
 Contract No. 226-05
 Designed MP
 Checked EB
 File No. _____
 Date 11/6/51
 Date 2/20/51

$$Q_{02} = Q_0 \left(1 - \frac{V_1}{S_{MAX}} \right) = 4650 \left(1 - \frac{13.43}{80} \right) = 4036 \text{ CFS}$$

THIS REACH SERVES AS A STORAGE AREA PRIMARILY, AND THE PEAK OUTFLOW, 4036 CFS, WHEN ROUTED THROUGH THE NEXT CONSECUTIVE D/S REACH (WHICH IS A CONSTRUCTION AND THEREFORE CONTROLS) MUST YIELD AN APPROXIMATELY EQUIVALENT STAGE OR A RECOMPUTATION IS PERFORMED BY ASSUMING A NEW INITIAL STAGE.
 * SUBJECT TO INCREASE CAUSED BY D/S CONTROL SECTION AT 2ND HOUSE AREA.

C. ESTIMATE OF DOWNSTREAM FAILURE CONDITIONS AT POTENTIAL IMPACT

2nd HOUSE AREA

i. REACH OF CURTIS POND BROOK BETWEEN DAM AND IMPACT AREA.

THE 1000-FT LONG REACH OF CURTIS POND BROOK FROM THE DAM TO THE IMPACT AREA IS APPROXIMATELY SHAPED AS SHOWN ON THE SKETCH BELOW:

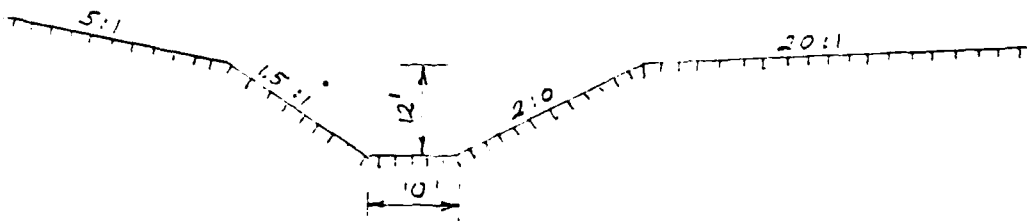

THE AVERAGE SLOPE OF THE REACH $S = 0.005$

ii. APPROXIMATE STAGE AT POTENTIAL IMPACT AREA

$L = 500 \text{ FT}$, $n = 0.05$, $S = 0.005$; STAGE-DISCHARGE CURVES ARE ON P. D-3

PREPARED DISCHARGE $Q = 6200 \text{ CFS}$, $H = 6.0 \text{ FT}$, $A = 125 \text{ FT}^2$

PREPARED STORAGE $V = 1.44 \times 10^6 \text{ CU FT}$

Project NDI^o
 Feature CURTIS POND DAM
 Item _____

Sheet 0-6
 Contract No. 268-01 File No. _____
 Designed TD Date 11/2/21
 Checked EB BJ Date 11/20/21

FAILURE DISCHARGE $Q_0 = 4036 \text{ CFS}$, ASSUME $Y_1^1 = 14 \text{ FT}$, $A_1 = 540 \text{ F}^2$

FAILURE STORAGE $V_1^1 = 500 \times 540 = 6,200 \text{ AC-FT}$

$V_1 = V_1^1 - V = 6,200 - 1,400 = 4,800 \text{ AC-FT} < \frac{1}{2} S_{U_1} = 4,500 \text{ AC-FT}$ OK

$Q_{0_2} = 4036 \left(1 - \frac{4.8}{80 - 13.43}\right) = 3745 \text{ CFS}$, $\therefore Y_2^1 = 14.7 \text{ FT}$, $A_2 = 620 \text{ F}^2$

$V_2^1 = 7.12 \text{ AC-FT}$ $\therefore V_2 = 7.12 - 1.4 = 5.72 \text{ AC-FT}$; $V = 5.26 \text{ AC-FT}$

$\therefore Q_{0_3} = 4036 \left(1 - \frac{5.26}{80 - 13.43}\right) = 3720 \text{ CFS}$; STAGE $Y_3 \approx 14.7 \text{ FT}$

RAISE IN STAGE AT IMPACT AREA $L_1 = Y_3 - Y = 14.7 - 6 = 8.7 \text{ FT}$

III. SELECTION OF TEST FLOOD

I. CLASSIFICATION OF DAM ACCORDING TO MED-HOE (SEE FIG. 1)

- a. SIZE: STORAGE (MAX) $\approx 80 \text{ AC-FT}$ ($50 < S < 1000 \text{ AC-FT}$)
 HEIGHT = 14 FT ($H < 25 \text{ FT}$)

NOTE: STORAGE (SEE P. D-1), HEIGHT (SEE P. D-3)

\therefore SIZE CLASSIFICATION: SMALL

b. HAZARD POTENTIAL: AS A RESULT OF THE DOWNSTREAM FAILURE ANALYSIS

THERE IS A POTENTIAL FOR THE LOSS OF MORE THAN A FEW LIVES
 DUE TO THE FAILURE OF CURTIS POND DAM. THEREFORE,
 THE DAM IS CLASSIFIED AS HAVING;

HAZARD POTENTIAL: HIGH



Project NDIP
 Feature CURTIS POND DAM
 Item _____

Sheet D-16
 Contract No. 263-75 File No. _____
 Designed 7/10 Date 1/6 51
 Checked EE Ry Date 1/20 51

2. TEST FLOOD: 1/2 PMF = 1805 CFS

THIS CLASSIFICATION IS MADE ON THE RESULTS OF THE PREVIOUS ANALYSIS AND CLASSIFICATION.

IV SUMMARY

1. TEST FLOOD: 1/2 PMF = 1805 CFS

(PARALLEL COMPUTATIONS HAVE BEEN MADE FOR PMF = 3610 CFS)

2. PERFORMANCE AT PEAK FLOOD CONDITIONS:

a. PEAK INFLOW: $Q_p' = 1/2 \text{ PMF} = 1805 \text{ CFS}$

b. PEAK OUTFLOW: $Q_{p3}' = 1670 \text{ CFS}$

c. SPILLWAY CAPACITY:

i. SPILLWAY CAPACITY TO TOP OF DAM EL. 331:

$$H = 4 \text{ FT}, \quad (Q_s)_1 = 620 \text{ CFS OR } 37\% \text{ OF } Q_{p3}'$$

ii. SPILLWAY CAPACITY TO 1/2 PMF SURCHARGE EL. 332.2':

$$H = 5.2 \text{ FT}; \quad (Q_s)_3 = 320 \text{ CFS OR } 55\% \text{ OF } Q_{p3}'$$

THEREFORE, AT TEST FLOOD $Q_p' = 1/2 \text{ PMF}$ THE DAM IS OVERTOPPED TO

A DEPTH OF 1.2' FT (VS. EL. 331) OR TO A SURCHARGE OF 5.2' --

INTERNATIONAL ENGINEERING COMPANY, INC.
Project NDIP
Feature CURTIS POND DAM
Item _____

Sheet 111
Contract No. 265-05 File No. _____
Designed M.P. Date 1/6/81
Checked E.P. By Date 1/20/81

3. DOWNSTREAM FAILURE CONDITIONS :

a. PEAK FAILURE OUTFLOW : $Q \approx 4230 \text{ CFS}$

b. FLOOD DEPTH IMMEDIATELY DOWNSTREAM FROM DAM :

$$Y_0 \approx 6.2 \text{ FT}$$

c. CONDITIONS AT THE INITIAL IMPACT AREA DOWNSTREAM FROM

DAM (CURTIS POND BROOK)

(1) FIRST HOUSE :

i. APPROXIMATE STAGE BEFORE FAILURE : $Y \approx 4.0 \text{ FT}$

ii. APPROXIMATE STAGE AFTER FAILURE : $Y_3 \approx 14.0 \text{ FT}$

iii. APPROXIMATE RISE IN STAGE AFTER FAILURE : $\Delta Y \approx 10.0 \text{ FT}$

(2) SECOND HOUSE :

i. APPROXIMATE STAGE BEFORE FAILURE : $Y \approx 6.0 \text{ FT}$

ii. APPROXIMATE STAGE AFTER FAILURE : $Y_3 \approx 14.7 \text{ FT}$

iii. APPROXIMATE RISE IN STAGE : $\Delta Y \approx 8.7 \text{ FT}$

APPENDIX E

INFORMATION AS CONTAINED IN THE
NATIONAL INVENTORY OF DAMS

NOT AVAILABLE AT THIS TIME

ATE
LMED
— 8