

MICROCOPY RESOLUTION TEST CHART  
NATIONAL BUREAU OF STANDARDS-1963-A

AD-A144 129



QUINNIPIAC RIVER BASIN  
MERIDEN/CHESHIRE, CONNECTICUT

BROAD BROOK DAM  
CT. 00301

PHASE I INSPECTION REPORT  
NATIONAL DAM INSPECTION PROGRAM

DTIC FILE COPY



DISTRIBUTION STATEMENT A  
Approved for public release  
Distribution Unlimited

DTIC  
ELECTE  
AUG 13 1984  
S D D

DEPARTMENT OF THE ARMY  
NEW ENGLAND DIVISION, CORPS OF ENGINEERS  
WALTHAM, MASS. 02154

SEPTEMBER 1978

84 08 09 081

UNCLASSIFIED

SECURITY CLASSIFICATION OF THIS PAGE (When Data Entered)

REPORT DOCUMENTATION PAGE		READ INSTRUCTIONS BEFORE COMPLETING FORM
1. REPORT NUMBER CT 00301	2. GOVT ACCESSION NO. AD-A144129	3. RECIPIENT'S CATALOG NUMBER
4. TITLE (and Subtitle) Broad Brook Dam		5. TYPE OF REPORT & PERIOD COVERED INSPECTION REPORT
NATIONAL PROGRAM FOR INSPECTION OF NON-FEDERAL DAMS		6. PERFORMING ORG. REPORT NUMBER
7. AUTHOR(s) U.S. ARMY CORPS OF ENGINEERS NEW ENGLAND DIVISION		8. CONTRACT OR GRANT NUMBER(s)
9. PERFORMING ORGANIZATION NAME AND ADDRESS		10. PROGRAM ELEMENT, PROJECT, TASK AREA & WORK UNIT NUMBERS
11. CONTROLLING OFFICE NAME AND ADDRESS DEPT. OF THE ARMY, CORPS OF ENGINEERS NEW ENGLAND DIVISION, NEDED 424 TRAPELO ROAD, WALTHAM, MA. 02254		12. REPORT DATE September 1978
14. MONITORING AGENCY NAME & ADDRESS (if different from Controlling Office)		13. NUMBER OF PAGES 55
		15. SECURITY CLASS. (of this report) UNCLASSIFIED
		16a. DECLASSIFICATION/DOWNGRADING SCHEDULE
16. DISTRIBUTION STATEMENT (of this Report) APPROVAL FOR PUBLIC RELEASE: DISTRIBUTION UNLIMITED		
17. DISTRIBUTION STATEMENT (of the abstract entered in Block 20, if different from Report)		
18. SUPPLEMENTARY NOTES Cover program reads: Phase I Inspection Report, National Dam Inspection Program; however, the official title of the program is: National Program for Inspection of Non-Federal Dams; use cover date for date of report.		
19. KEY WORDS (Continue on reverse side if necessary and identify by block number) DAMS, INSPECTION, DAM SAFETY,  Quinnipiac River Basin Meriden/Cheshire, Connecticut		
20. ABSTRACT (Continue on reverse side if necessary and identify by block number) The Broad Brook Dam is a concrete dam that is 210 ft. long with a 70 ft. spillway. It has a gate house with a 30 inch diameter blowoff and a 30 inch diameter water main. Based on the visual inspection, records available at the site and past operational performance, the dam is judged to be in poor condition.		

Accession For	
NTIS GRA&I	<input checked="" type="checkbox"/>
DTIC TAB	<input type="checkbox"/>
Unannounced	<input type="checkbox"/>
Justification	
By _____	
Distribution/	
Availability Codes	
Dist	Avail and/or Special
A/1	

BROAD BROOK DAM  
CT. 00301

DSID  
COPY  
INSPECTED  
2

QUINNIPIAC RIVER BASIN  
MERRIDEN/CHESHIRE, CONNECTICUT

PHASE I INSPECTION REPORT  
NATIONAL DAM INSPECTION PROGRAM

DTIC  
ELECTE  
AUG 13 1984  
S D D

**DISTRIBUTION STATEMENT A**  
Approved for public release;  
Distribution Unlimited



DEPARTMENT OF THE ARMY  
NEW ENGLAND DIVISION, CORPS OF ENGINEERS  
424 TRAPELO ROAD  
WALTHAM, MASSACHUSETTS 02154

REPLY TO  
ATTENTION OF:  
NEDED

SEP 29 1979

Honorable Ella T. Grasso  
Governor of the State of Connecticut  
State Capitol  
Hartford, Connecticut 06115

Dear Governor Grasso:

Inclosed is a copy of the Broad Brook Dam Phase I Inspection Report, which was prepared under the National Program for Inspection of Non-Federal Dams. This report is presented for your use and is based upon a visual inspection, a review of the past performance and a brief hydrological study of the dam. A brief assessment is included at the beginning of the report. I have approved the report and support the findings and recommendations described in Section 7 and ask that you keep me informed of the actions taken to implement them. This follow-up action is a vitally important part of this program.

A copy of this report has been forwarded to the Department of Environmental Protection, the cooperating agency for the State of Connecticut. In addition, a copy of the report has also been furnished the owner, City of Meriden, Connecticut.

Copies of this report will be made available to the public, upon request, by this office under the Freedom of Information Act. In the case of this report the release date will be thirty days from the date of this letter.

I wish to take this opportunity to thank you and the Department of Environmental Protection for your cooperation in carrying out this program.

Sincerely,

MAX B. SCHEIDER  
Colonel, Corps of Engineers  
Division Engineer

Incl  
As stated

NATIONAL DAM INSPECTION PROGRAM

PHASE I INSPECTION REPORT

Identification Number: CT 00301  
Name: Broad Brook Dam  
Town: Cheshire  
County and State: New Haven County, Connecticut  
Stream: Tributary to the Quinnipiac River  
Date of Inspection: July 25, 1978

BRIEF ASSESSMENT

The Broad Brook Dam is a concrete dam that is 210 feet long with a 70 foot spillway. It has a gate house with a 30 inch diameter blowoff and a 30 inch diameter water main.

Based on the visual inspection, records available at the site and past operational performance, the dam is judged to be in poor condition. A review of the limited engineering data available reveals that there are areas of concern that should be corrected or investigated further as to their effect on the integrity of the dam.

The east bank on the downstream side of the dam shows signs of fairly heavy seepage. This condition should be investigated further.

The project spillway will pass only 26 percent of the estimated Probable Maximum Flood (PMF), the recommended

spillway test flood. Therefore, further hydrologic and hydraulic studies are recommended to refine the spillway test flood, determine the ability of the dam to withstand overtopping, and if appropriate, measures for increasing spillway capacity.

Plans for around the clock surveillance should be developed for periods of unusually heavy rains and a formal warning system should be developed for use in the event of an emergency.

Recommended measures to be undertaken by the owner include monitoring seepage, studying the overall condition of the dam (cracks, erosion and areas of distress), studying vibration during high flows and establishing an inspection program. The owner should implement the recommendations and remedial measures described in Section 7 within one year after receipt of this Phase I Inspection Report.

*Joseph F. Merluzzo*

Joseph F. Merluzzo  
Connecticut P.E. #7639  
Project Manager

*Richard F. Lyon*

Richard F. Lyon  
Connecticut P.E. #8443  
Project Engineer

This Phase I Inspection Report on Broad Brook Dam has been reviewed by the undersigned Review Board members. In our opinion, the reported findings, conclusions, and recommendations are consistent with the Recommended Guidelines for Safety Inspection of Dams, and with good engineering judgment and practice, and is hereby submitted for approval.

*Charles G. Tiersch*

CHARLES G. TIERSCH, Chairman  
Chief, Foundation and Materials Branch  
Engineering Division

*Fred J. Ravens, Jr.*

FRED J. RAVENS, Jr., Member  
Chief, Design Branch  
Engineering Division

*Saul Cooper*

SAUL COOPER, Member  
Chief, Water Control Branch  
Engineering Division

APPROVAL RECOMMENDED:

*Joe B. Fryar*

JOE B. FRYAR  
Chief, Engineering Division

## PREFACE

This report is prepared under guidance contained in the Recommended Guidelines for Safety Inspection of Dams, for Phase I Investigations. Copies of these guidelines may be obtained from the Office of Chief of Engineers, Washington, D.C. 20314. The purpose of a Phase I Investigation is to identify expeditiously those dams which may pose hazards to human life or property. The assessment of the general condition of the dam is based upon available data and visual inspections. Detailed investigations and analyses involving topographic mapping, subsurface evaluations, testing, and detailed computational evaluations are beyond the scope of a Phase I Investigation; however, the investigation is intended to identify the need for such studies.

In reviewing this report, it should be realized that the reported condition of the dam is based on observations of field conditions at the time of inspection along with data available to the inspection team. In cases where the reservoir was lowered or drained prior to inspection, such action, while improving the stability and safety of the dam, removes the normal load on the structure and may obscure certain conditions which might otherwise be detectable if inspected under the normal operating environment of the structure.

It is important to note that the condition of a dam depends on numerous and constantly changing internal and external conditions, and is evolutionary in nature. It would be incorrect to assume that the present condition of the dam will continue to represent the condition of the dam at some point in the future. Only through continued care and inspection can there be any chance that unsafe conditions be detected.

Phase I Inspections are not intended to provide detailed hydrologic and hydraulic analyses. In accordance with the established Guidelines, the Spillway Test Flood is based on the estimated "Probable Maximum Flood" for the region (greatest reasonably possible storm runoff), or fractions thereof. Because of the magnitude and variety of such a storm event, a finding that a spillway will not pass the test flood should not be interpreted as necessarily posing a highly inadequate condition. The test flood provides a measure of relative spillway capacity and serves as an aide in determining the need for more detailed hydrologic and hydraulic studies, considering the size of the dam, its general condition and the downstream damage potential.

## TABLE OF CONTENTS

	<u>Page</u>
LETTER OF TRANSMITTAL	
BRIEF ASSESSMENT . . . . .	i
BRIEF ASSESSMENT . . . . .	ii
REVIEW BOARD PAGE . . . . .	iii
PREFACE . . . . .	iv
TABLE OF CONTENTS . . . . .	v
TABLE OF CONTENTS . . . . .	vi
OVERVIEW PHOTO	
LOCATION MAP . . . . .	vii
REPORT	
SECTION 1 - PROJECT INFORMATION	
1.1 General . . . . .	1
1.2 Description of Project . . . . .	2
1.3 Pertinent Data . . . . .	3
SECTION 2 - ENGINEERING DATA	
2.1 Design . . . . .	7
2.2 Construction . . . . .	7
2.3 Operation . . . . .	7
2.4 Evaluation . . . . .	8
SECTION 3 - VISUAL INSPECTION	
3.1 Findings . . . . .	9
3.2 Evaluation . . . . .	11
SECTION 4 - OPERATIONAL PROCEDURES	
4.1 Procedures . . . . .	13
4.2 Maintenance of Dam . . . . .	13
4.3 Maintenance of Operating Facilities . . . . .	13
4.4 Description of Warning System . . . . .	14
4.5 Evaluation . . . . .	14

TABLE OF CONTENTS (CONTINUED)

	<u>Page</u>
SECTION 5 - HYDRAULIC/HYDROLOGIC	
5.1 Evaluation of Features . . . . .	15
SECTION 6 - STRUCTURAL STABILITY	
6.1 Evaluation of Structural Stability . . . . .	17
SECTION 7 - ASSESSMENT, RECOMMENDATIONS & REMEDIAL MEASURES	
7.1 Dam Assessment . . . . .	19
7.2 Recommendations . . . . .	20
7.3 Remedial Measures . . . . .	22
<u>APPENDIX MATERIALS</u>	
A VISUAL INSPECTION CHECK LIST . . . . .	A-1 to A-6
B LIST OF REFERENCES . . . . .	B-1
GENERAL PLAN . . . . .	Plate 1
SECTION AND DETAILS . . . . .	Plates 2 & 3
C PHOTO LOCATION PLAN . . . . .	Plate 4
PHOTOGRAPHS . . . . .	II-1 to II-4
D HYDRAULIC COMPUTATIONS . . . . .	D-1 to D-9
REGIONAL VICINITY MAP . . . . .	Plate 5
E INFORMATION AS CONTAINED IN THE NATIONAL INVENTORY OF DAMS . . . . .	



OVERVIEW PHOTO

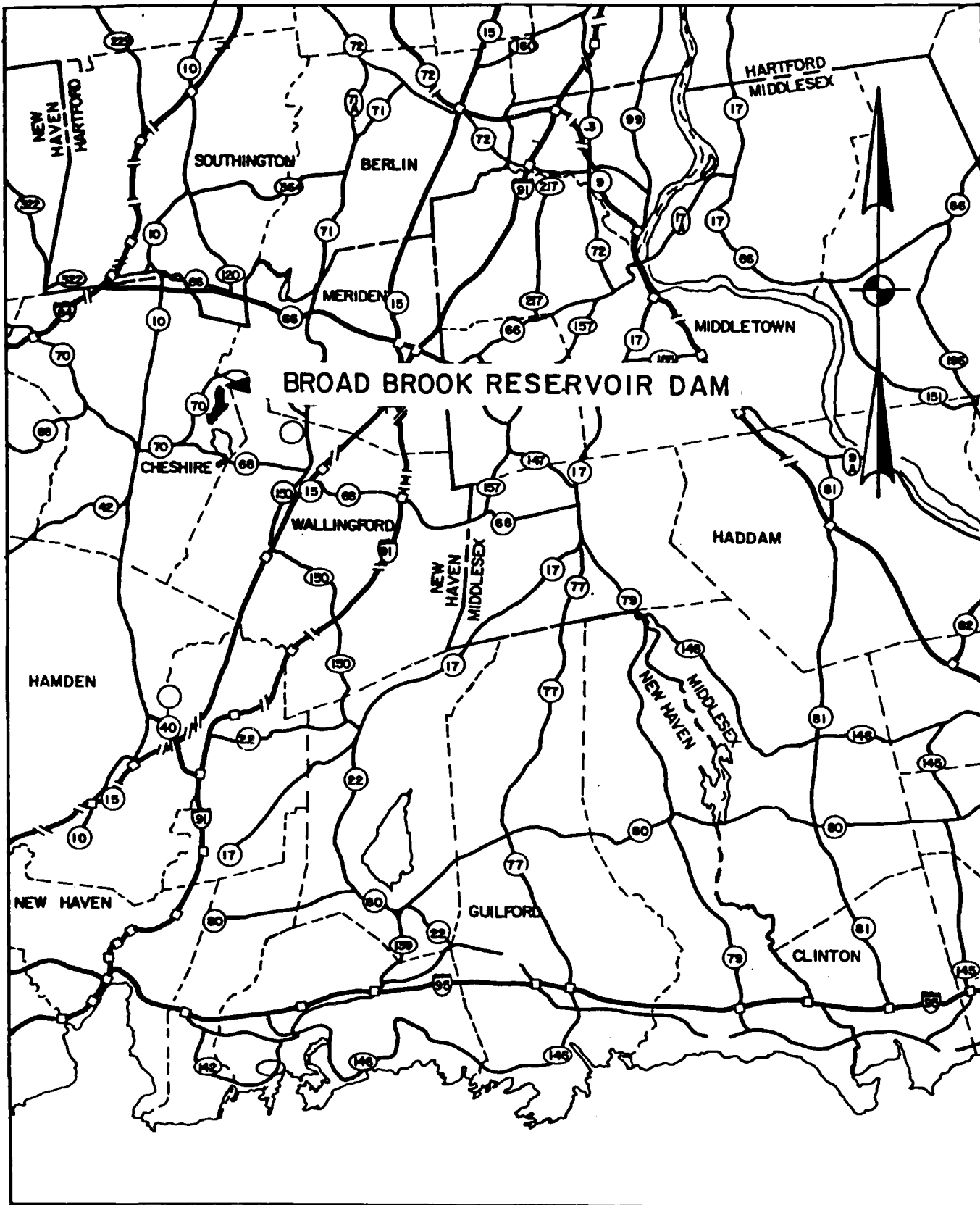

U.S. ARMY, CORPS OF ENGINEERS  
 NEW ENGLAND DIVISION  
 WALTHAM, MASS.



LOCATION MAP

## PHASE I INSPECTION REPORT

### BROAD BROOK DAM

#### SECTION 1 - PROJECT INFORMATION

##### 1.1 General

a. Authority - Public Law 92-367, August 8, 1972 authorized the Secretary of the Army, through the Corps of Engineers, to initiate a National Program of Dam Inspection throughout the United States. The New England Division of the Corps of Engineers has been assigned the responsibility of supervising the inspection of dams within the New England Region. Storch Engineers has been retained by the New England Division to inspect and report on selected dams in the State of Connecticut. Authorization and notice to proceed were issued to Storch Engineers under a letter of May 3, 1978 from Ralph T. Garver, Colonel, Corps of Engineers. Contract No. DACW33-78-C-0000 has been assigned by the Corps of Engineers for this work.

b. Purpose -

(1) Perform technical inspection and evaluation of non-Federal dams to identify conditions which threaten the public safety and thus permit correction in a timely manner by non-Federal interests.

(2) Encourage and prepare the states to initiate quickly, effective dam safety programs for non-Federal dams.

(3) To update, verify and complete the National Inventory of Dams.

## 1.2 Description of Project

The Broad Brook Dam is one of 12 dams owned and operated by the Meriden Water Department, New Haven County, Connecticut.

It is located just outside of the City of Meriden right on the border of the Town of Cheshire (see Location Map) and is on Broad Brook, a part of the Quinnipiac River Basin.

The structure consists of a concrete dam that is approximately 210 feet long with the spillway length of approximately 70 feet. It has a gate house with a 30 inch diameter blowoff and a 30 inch diameter pipe to the newly constructed water treatment plant just downstream of the dam. The dam impounds the Broad Brook Reservoir which serves as a primary water supply for the City of Meriden.

The size classification of the dam is intermediate (50 feet high and 3,870 acre-feet of storage) and the hazard classification is high per the criteria set forth in the Recommended Guidelines for Safety Inspection of Dams by the Corps of Engineers. Immediately downstream is the Broad

Brook Water Filtration Plant which was recently reconstructed. Failure of this dam would result in severe damage to this facility and the loss of water for many water users in the City of Meriden.

The Broad Brook Dam was constructed in 1913 from designs prepared by the Meriden Water Department. There is a regular staff of maintenance personnel available at the water treatment plant but the maintenance performed on this dam is minimal. In 1927, the spillway was reconditioned and a drainage system for the body of the dam was installed (Appendix B, Plate 2). In 1976 and 1977 when the new plant was constructed, the sluice gate in the upper gate house was replaced.

The person in charge of day to day operation of the dam is Bruce Soroka, City Engineer, Meriden, Connecticut; Telephone Number: 634-0003.

### 1.3 Pertinent Data

a. Drainage Area - A 5.0 square mile drainage area contributes to the dam. The terrain is rolling with mixed amounts of farm land, orchards and residential development.

b. Discharge at Damsite - The maximum known spillway discharge was approximately 1,120 cfs during the flood of September, 1938.

(1) Outlet works: 30 inch conduit at invert elevation 85.0.

(2) Maximum known flood at damsite: 1,120 cfs.

(3) Ungated spillway capacity at maximum pool elevation:  
1,450 cfs at 122.0 elevation.

(4) Gated spillway capacity at pool elevation N/A cfs  
at N/A elevation.

(5) Gated spillway capacity at maximum pool elevation  
N/A cfs at N/A elevation.

(6) Total spillway capacity at maximum pool elevation:  
1,450 cfs at 122 elevation.

c. Elevation (Feet above MSL)

(1) Top of dam: 122.0

(2) Maximum pool-design surcharge: 122.0

(3) Full flood-control pool: N/A

(4) Recreation pool: N/A

(5) Spillway crest: 119.0

(6) Upstream portal invert diversion tunnel: 85.0

(7) Streambed at centerline of dam: 85.0

(8) Maximum tailwater (1938 Flood): 87.2

d. Reservoir

(1) Length of maximum pool: 12,000 feet ±

(2) Length of recreation pool: N/A

(3) Length of flood-control pool: N/A

e. Storage (Acre-Feet)

(1) Recreation pool: N/A

(2) Flood-control pool: N/A

- (3) Design surcharge: 3,870 ±
- (4) Top of dam: 3,870 ±
- f. Reservoir Surface (Acres)
  - (1) Top dam: 422 ±
  - (2) Maximum pool: 422 ±
  - (3) Flood-control pool: N/A
  - (4) Recreation pool: N/A
  - (5) Spillway crest: 294 ±
- g. Dam
  - (1) Type: Concrete - Gravity
  - (2) Length: 212 feet ±
  - (3) Height: 49 feet ±
  - (4) Top width: 8 feet ±
  - (5) Side Slopes: U/S - 1:0.05  
D/S - 1:2 ±
  - (6) Zoning: N/A
  - (7) Impervious Core: N/A
  - (8) Cutoff: 4 feet ±
  - (9) Grout curtain: unknown
  - (10) Other: N/A
- h. Diversion and Regulating Tunnel (Conduit)
  - (1) Type: cast iron
  - (2) Length: 42 feet ±
  - (3) Closure: Not applicable
  - (4) Access: none

(5) Regulating facilities: Manually operated gate

i. Spillway

(1) Type: concrete - fixed weir

(2) Length of weir: 70 feet

(3) Crest elevation: 119.0 feet

(4) Gates: 12" flashboards (poor condition)

(5) U/S Channel: underwater

(6) D/S Channel: natural channel

(7) General: N/A

j. Regulating Outlets

Regulating outlets include a 30 inch blowoff that discharges just below the dam and a 30 inch water main that goes to the treatment plant several hundred feet downstream.

(1) Invert: 85.0

(2) Size: 30 inch

(3) Description: cast iron

(4) Control mechanism: manually operated gate valves

(5) Other: N/A

## SECTION 2 - ENGINEERING DATA

### 2.1 Design

The available design information for this dam is in the form of contract drawings and two separate engineering studies. The first study was started by a private consultant and was not completed because of lack of funds. The second study was done by the Meriden Water Department to evaluate the effects of placing flashboards on top of the spillway.

In 1927, the face of the spillway was capped with 1.5 feet of concrete. An internal drainage system was installed at this time (Appendix B, Plate 2).

### 2.2 Construction

There are no records or photographs available for the construction of the original dam. The as-built information is contained on the contract plans, dated 1974, that were prepared for the gate house repair.

### 2.3 Operation

The operation of the sluice gates in the upper gate house structure is manual. In 1977, the 30 inch diameter sluice gate to the main plant as well as the valve for the blowoff line were repaired. The percentage of flow that can be released through these pipes is small and there is no

formal or written plan available for these valves to be opened during a storm. The spillway discharges about six months out of the year.

#### 2.4 Evaluation

a. Availability - The construction drawings were readily available. Because of the age of the dam, there was no design information. The dam has no operating procedures.

b. Adequacy - The information that was made available was only a minor factor in the assessment, which was based mainly on the visual inspection, past performance history and hydrologic and hydraulic assumptions.

c. Validity - The construction drawings are accurate to the extent that the visible inspection did not reveal any new features.

## SECTION 3 - VISUAL INSPECTION

### 3.1 Findings

a. General - The visual inspection was conducted on July 25, 1978 by members of the engineering staff of Storch Engineers, with the help of Mr. Donald Perry of the Meriden Water Department. A copy of the visual inspection check list is contained in the Appendix of this report.

The following procedures was used for the inspection:

1. The concrete face of the dam was surveyed for cracks, spalling, seepage and efflorescence.
2. The banks downstream of the dam were inspected for leakage or water loss.
3. The upstream face of the dam was checked for structural damage.
4. A visual check was made for bulges or movement in the existing embankment.
5. The temperature was taken of the upstream and downstream water as well as that of the seepage flow.
6. The dam and its appurtenant structures (Appendix C, Plate 4) were photographed.

Before the inspection commenced, the design and construction documents were studied and a compact sketch of the dam was prepared for use during the inspection (Appendix B, Plate 1).

In general, the overall condition of the dam and appurtenant structures is poor.

b. Dam - An inspection of the downstream face of the spillway revealed several areas which had spalled or showed signs of seepage. In one location on the west side of the spillway reinforcing bars were exposed. The concrete showed signs of distress to a depth of 2 to 4 inches, especially along the horizontal construction joints. The upstream face of the dam showed some signs of minor erosion and concrete spalling. A search for the four inch diameter outlet of the underdrain system that is shown on Plate 2, Appendix B, was not successful because of the considerable amount of silt deposited at the toe of the spillway. The wooden flashboards on the spillway were badly weathered and appeared useless.

On the east bank of the downstream side of the dam for a distance of about 200' ± there are wet spots that seem to flow at a fairly steady rate approximately 10 to 30 gallons/min. These wet areas are noticeable over the entire lower half of the slope and the approximate limits have been delineated on Plate 1, Appendix B. This bank has been completely overgrown with trees and underbrush.

c. Appurtenant Structures - The gate house has recently been repaired along with its gates, valves and operators during the recent treatment plant reconstruction. A conversation with the plumber, who made the modifications to the service gates, revealed that no major leaks into the gate house chamber were observed. The 30 inch diameter blowoff and water supply pipes are enclosed within the body of the dam. Although this gate house is somewhat unsightly, it appears structurally sound.

d. Reservoir Area - An inspection of the embankment adjacent to or just slightly upstream from the dam showed the area to be in a natural state. The alignment of the dam is good and there are no signs of movement of the upstream embankment.

e. Downstream Channel - The spillway and core of the main dam are both cut into ledge rock (Appendix B, Plate 2). The downstream side is faced with an earth embankment except for the spillway area. The downstream banks are so overgrown with trees and dense brush that it is difficult to determine any abnormalities. The silt at the toe of the dam causes the seepage water to lie stagnant during those times when the spillway is not flowing.

### 3.2 Evaluation

The visual inspection of this facility revealed some apparent areas of distress in the concrete. The observation of the extensive zone of seepage on the downstream slope of the dam indicates a need for further study so that the extent of this problem can be defined. Overall, the general condition of the dam is poor.

## SECTION 4 - OPERATIONAL PROCEDURES

### 4.1 Procedures

The piping for this facility is operated only as required for the water treatment plant or if a drawdown of the reservoir is desired. There has been no formal procedure established for the lowering of the reservoir during periods of flooding. The maintenance staff that takes care of the Broad Brook Water Filtration Plant is also responsible for the maintenance of the dam.

### 4.2 Maintenance of the Dam

There is no routine maintenance procedure, however, there have been attempts to clear some of the undergrowth away from the face of the dam. Items such as clearing the downstream banks, repair of the internal drainage system and restoration of the concrete surface of the spillway does not appear to have been attempted recently.

### 4.3 Maintenance of Operating Facilities

The maintenance of the facilities which operate the dam consists of exercising the operators of the sluice gates and valves to the water main and blowoff and changing the screen in the well of the gate house.

During the reconstruction of the water treatment plant in 1976 and 1977, the stems in the gate house which operate the valves and sluice gates for the 30 inch main and blowoff were repaired. The frequency of operation prior to this repair had been minimal.

#### 4.4 Description of Warning System

There is no warning system in effect.

#### 4.5 Evaluation

In view of the lack of routine maintenance procedures, it is suggested that written procedures be established. There has been no recent effort made to clean-up the downstream area or to repair damage to the body of the dam itself.

## SECTION 5 - HYDRAULIC/HYDROLOGIC

### 5.1 Evaluation of Features

a. Design Data - The 70 foot spillway, 30 inch blowoff and 30 inch water main are the only means of transmitting water past the dam. Under conditions of the Probable Maximum Flood (PMF), the spillway will carry only a portion of the flood water.

Using the guide curves supplied by the Corps of Engineers (rolling terrain), the PMF inflow into the reservoir is 9,250 cfs and the routed outflow is 5,500 cfs. The pond elevation at the PMF is 124.5 or 2.5 feet over the top of the dam. The Spillway Design Flood (SDF) is only 1,450 cfs, approximately 26 percent of the PMF (Appendix D).

b. Experience Data - The Broad Brook Reservoir Dam has experienced the floods of November, 1927; March, 1936; September, 1938 (maximum) and August and October, 1955. During the flood of September 1938, the elevation of the pond was 121.75 feet and the discharge was approximately 1,120 cfs.

c. Visual Observations - The spillway at the time of the inspection was in poor condition with some evidence of water seeping through its construction joints (Appendix C, Photo 5).

The river channel downstream is overgrown with trees and brush and is not conducive to the free passage of flood flows. This condition is found from the dam to the confluence of Broad Brook with the Quinnipiac River.

The 30 inch blowoff and the 30 inch water main are in good condition.

d. Overtopping Potential - Calculations by Storch Engineers indicates that the PMF will overtop the dam by 4.2 feet. However, since the dam is constructed of concrete, it may withstand some overtopping. One half of the PMF would result in about one foot of overtopping.

## SECTION 6 - STRUCTURAL STABILITY

### 6.1 Evaluation of Structural Stability

a. Visual Observations - There are no routine inspections performed by the staff of the Meriden Water Department, however, maintenance personnel from the treatment plant operate the sluice gate of the water supply main as necessary. The results of the visual inspection showed that the structure is stable, however, the deep concrete damages and extensive seepage on the east bank could cause problems during normal operation.

b. Design and Construction Data - The only design and construction data available were two original contract drawings of September, 1929 and the oral information of the resident staff.

c. Operating Records - There are no operating records. The water level of the Broad Brook Reservoir is not monitored.

d. Post Construction Changes - The following changes to the Broad Brook Reservoir Dam facility have been noted since the completion of construction in 1913:

1. Considerable damage to the concrete face of the dam, especially along the horizontal construction joints of the downstream slope of the spillway.

There are erosion areas which are four inches deep with rusted reinforcement that is exposed (Appendix C, Photo 7).

2. The replacement of the deteriorated portions of the downstream concrete spillway slope in conjunction with the installation of a surface drainage system in September, 1929.

e. Seismic Stability - The dam is located in Seismic Zone No. 1 and in accordance with recommended Phase I guidelines does not warrant seismic analysis.

## SECTION 7 - ASSESSMENT, RECOMMENDATIONS & REMEDIAL MEASURES

### 7.1 Dam Assessment

a. Condition - After careful review of the available documents, the results of this inspection and the meetings with the resident staff, the conclusion is that the general condition of the Broad Brook Reservoir Dam is poor. Although there are no signs that the dam has insufficient structural stability, there are several evidences of damaged concrete, obstruction of the internal drainage system and intensive seepage areas on the east side of the downstream bank. Each of these deficiencies could lead to a dangerous condition in the future.

b. Adequacy of Information - The information available is such that the assessment of the safety of the dam should be based primarily on the visual inspection results and the past operational performance of the structures.

c. Urgency - The owner shall implement the recommendations within one year after receipt of this Phase I Inspection Report.

d. Need for Additional Investigation - Additional observations and investigations of the dam by a qualified engineering firm should be initiated especially in the areas of seepage, underground water pressure and concrete properties.

## 7.2 Recommendations

In view of the concern for the safety of the dam and the lack of the engineering data for the evaluation of its condition, it is recommended that the following measures be undertaken by the owner:

1. Instrumentation should be provided to monitor the dam behavior. This instrumentation should include the metering of upstream and downstream water levels, daily; seepage discharges in all springs on the east downstream bank and in other discovered springs including the body of the dam, monthly; and seepage pressure at the base of the dam by the installation of the piezometers, monthly.
2. Temperature of seepage water and reservoir water below the water surface at depths of 1 foot, 10 feet and 30 feet, monthly and simultaneously with the measurement of seepage discharges;
3. Chemical analyses of the reservoir and the seepage water in the all the springs, yearly and simultaneously with the measurement of discharge. The water should be checked for pH, hardness, Ca, Mg,  $\text{CO}_3$ ,  $\text{HCO}_3$ , Na+K and  $\text{CO}_2$ .

4. Sketches and photographs of the damaged surfaces (caverns, erosion areas, cracks, rust reinforcement and spalling) of the top, upstream (with reservoir level lowered) and downstream slopes of the dam and the concrete walls of the gate house, yearly. There should also be a measurement of the depth and area of these distresses and the width of cracks.
5. The vibration of the body of the dam during the passage of high flows across the spillway.
6. Determination of the exact geometrical size of the dam, the elevation of its base, the primary properties of the concrete and concrete masonry for assessment of structural stability.
7. A watershed study should be done so that the characteristics of the reservoir can be determined.
8. A systematic inspection program (once every two years) during periods of the highest and lowest reservoir water levels should be developed to assure that all features of the dam are continually maintained.

Any of the above recommendations that require additional investigation should be done by a qualified engineering firm.

### 7.3 Remedial Measures

It is considered important that the following items be attended to within one year:

- a. Alternatives - Not applicable.
- b. O & M Maintenance and Procedures -
  - (1) The grass, brush and trees on the downstream slopes of the dam and banks at the distance of 300 feet from the dam should be removed to facilitate the visual observation of existing and potential seepage.
  - (2) Restoration of the existing drainage system in the body of the dam.
  - (3) The repair of the concrete faces of the dam with the removal of weak and deteriorated concrete.
  - (4) The downstream channel of the spillway should be cleaned of rock deposits, brush and trees so that overflow discharges from the spillway and the blowoff can be passed freely.
  - (5) A formal warning system should be developed including an operational procedure to follow in the event of an emergency.
  - (6) The flashboards that are on top of the spillway should either be repaired or removed.

APPENDIX A

VISUAL INSPECTION CHECK LIST A-1 to A-6

VISUAL INSPECTION CHECK LIST  
PARTY ORGANIZATION

PROJECT Broad Brook Reservoir Dam

DATE: 7-25-78

TIME \_\_\_\_\_

WEATHER Sunny

W.S. ELEV. 118.75 U.S. 87.5 DN.S.

PARTY:

- |  |           |
|--|-----------|
| 1. <u>Richard Lyon</u>                   | 6. _____  |
| 2. <u>Miron Petrovsky</u>                | 7. _____  |
| 3. <u>Gary Giroux</u>                    | 8. _____  |
| 4. <u>John Schearer</u>                  | 9. _____  |
| 5. <u>Don Perry (Meriden Water Dept)</u> | 10. _____ |

PROJECT FEATURE

INSPECTED BY

REMARKS

- |           |       |       |
|-----------|-------|-------|
| 1. _____  | _____ | _____ |
| 2. _____  | _____ | _____ |
| 3. _____  | _____ | _____ |
| 4. _____  | _____ | _____ |
| 5. _____  | _____ | _____ |
| 6. _____  | _____ | _____ |
| 7. _____  | _____ | _____ |
| 8. _____  | _____ | _____ |
| 9. _____  | _____ | _____ |
| 10. _____ | _____ | _____ |

Temperature of Air 80° F

Temperature of Water 80° F (upstream)

Temperature of Seepage 62° F

PERIODIC INSPECTION CHECK LIST

PROJECT Broad Brook Reservoir Dam DATE 7-25-78

PROJECT FEATURE \_\_\_\_\_ NAME R. Lyon

DISCIPLINE \_\_\_\_\_ NAME G. Giroux

AREA EVALUATED	CONDITIONS
<u>DAM EMBANKMENT</u>	
Crest Elevation	Fair
Current Pool Elevation	Fair
Maximum Impoundment to Date	Fair
Surface Cracks	Minor hairline cracks noted
Pavement Condition	N/A
Movement or Settlement of Crest	None observed
Lateral Movement	None observed
Vertical Alignment	Good
Horizontal Alignment	Good
Condition at Abutment and at Concrete Structures	Fair to good
Indications of Movement of Structural Items on Slopes	N/A
Trespassing on <del>Slopes</del> Dam	Not permitted (not patrolled)
Sloughing or Erosion of Slopes or Abutments	Some observed on face of concrete
Rock Slope Protection - Riprap Failures	N/A
Unusual Movement or Cracking at or near Toes	None observed
Unusual Embankment or Downstream Seepage	East bank shoed considerable leakage
Piping or Boils	None
Foundation Drainage Features	N/A
Toe Drains	None
Instructions	A-2 N/A



PERIODIC INSPECTION CHECK LIST

PROJECT Broad Brook Reservoir Dam

DATE 7-25-78

PROJECT FEATURE \_\_\_\_\_

NAME G. Giroux

DISCIPLINE \_\_\_\_\_

NAME M. Petrovsky

AREA EVALUATED	CONDITION
<b><u>OUTLET WORKS - CONTROL TOWER</u></b>	
<b>a. Concrete and Structural</b>	
General Condition	Fair to good
Condition of Joints	Good
Spalling	None
Visible Reinforcing	None
Rusting or Staining of Concrete	None
Any Seepage or Efflorescence	Underwater
Joint Alignment	Good
Unusual Seepage or Leaks in Gate Chamber	None (according to Contractor on job)
Cracks	N/A
Rusting or Corrosion of Steel	N/A
<b>b. Mechanical and Electrical</b>	
Air Vents	N/A
Float Wells	N/A
Crane Hoist	N/A
Elevator	N/A
Hydraulic System	N/A
Service Gates	Good condition (recently repaired)
Emergency Gates	
Lightning Protection System	N/A
Emergency Power System	N/A
Wiring and Lighting System in Gate Chamber	N/A

PERIODIC INSPECTION CHECK LIST

PROJECT Broad Brook Reservoir Dam

DATE 7-25-78

PROJECT FEATURE \_\_\_\_\_

NAME R. Lyon

DISCIPLINE \_\_\_\_\_

NAME J. Schearer

AREA EVALUATED	CONDITION
<p><u>OUTLET WORKS - TRANSITION AND CONDUIT</u></p> <p>General Condition of Concrete</p> <p>Rust or Staining on Concrete</p> <p>Spalling</p> <p>Erosion or Cavitation</p> <p>Cracking</p> <p>Alignment of Monoliths</p> <p>Alignment of Joints</p> <p>Numbering of Monoliths</p>	<p>Encased in the body of the dam.</p>

PERIODIC INSPECTION CHECK LIST

PROJECT Broad Brook Reservoir Dam

DATE 7-25-78

PROJECT FEATURE \_\_\_\_\_

NAME M. Petrovsky

DISCIPLINE \_\_\_\_\_

NAME G. Giroux

AREA EVALUATED	CONDITION
<p><u>OUTLET WORKS - SPILLWAY WEIR, APPROACH AND DISCHARGE CHANNELS</u></p> <p>a. Approach Channel</p> <p>General Condition</p> <p>Loose Rock Overhanging Channel</p> <p>Trees Overhanging Channel</p> <p>Floor of Approach Channel</p>	<p>Underwater</p>
<p>b. Weir and Training Walls</p> <p>General Condition of Concrete</p> <p>Rust or Staining</p> <p>Spalling</p> <p>Any Visible Reinforcing</p> <p>Any Seepage or Efflorescence</p> <p>Drain Holes</p>	<p>Good</p> <p>None</p> <p>Considerable amount on face of spillway</p> <p>Some observed on west side of spillway</p> <p>Many evidences at joints seen</p> <p>Drain hole could not be located</p>
<p>c. Discharge Channel</p> <p>General Condition</p> <p>Loose Rock Overhanging Channel</p> <p>Trees Overhanging Channel</p> <p>Floor of Channel</p> <p>Other Obstructions</p>	<p>Fair</p> <p>N/A</p> <p>Heavily overgrown</p> <p>Silt and loose material evident</p> <p>None</p>

APPENDIX B

LIST OF REFERENCES

B-1

GENERAL PLAN

Plate 1

SECTION AND DETAILS

Plates 2 and 3

References Nos. 1 and 2 are located at the Engineering Department, City of Meriden, Connecticut.

1. "Engineering Data of Dams of Meriden Water Department"; City Engineers' Office; Meriden, Connecticut.
2. "Plan, Elevation and Spillway Section of Broad Brook Dam, Contract Drawings; September 20, 1926; City Engineers' Office; Meriden, Connecticut.
3. Recommended Guidelines for Safety Inspection of Dams. Department of the Army; Office of the Chief of Engineers; Washington, D.C.; November, 1976.
4. Guide Curves for the Probable Maximum Flood (PMF) for Regions of New England based on past Corps of Engineers' March, 1978.
5. Preliminary Guidance for Estimating Maximum Probable Discharges in Phase I Dam Safety Investigations; New England Division; Corps of Engineers; March, 1978.
6. Rule of Thumb. Guidance for Estimating Downstream Dam Failure Hydrographs; Corps of Engineers; April, 1978.

BROAD

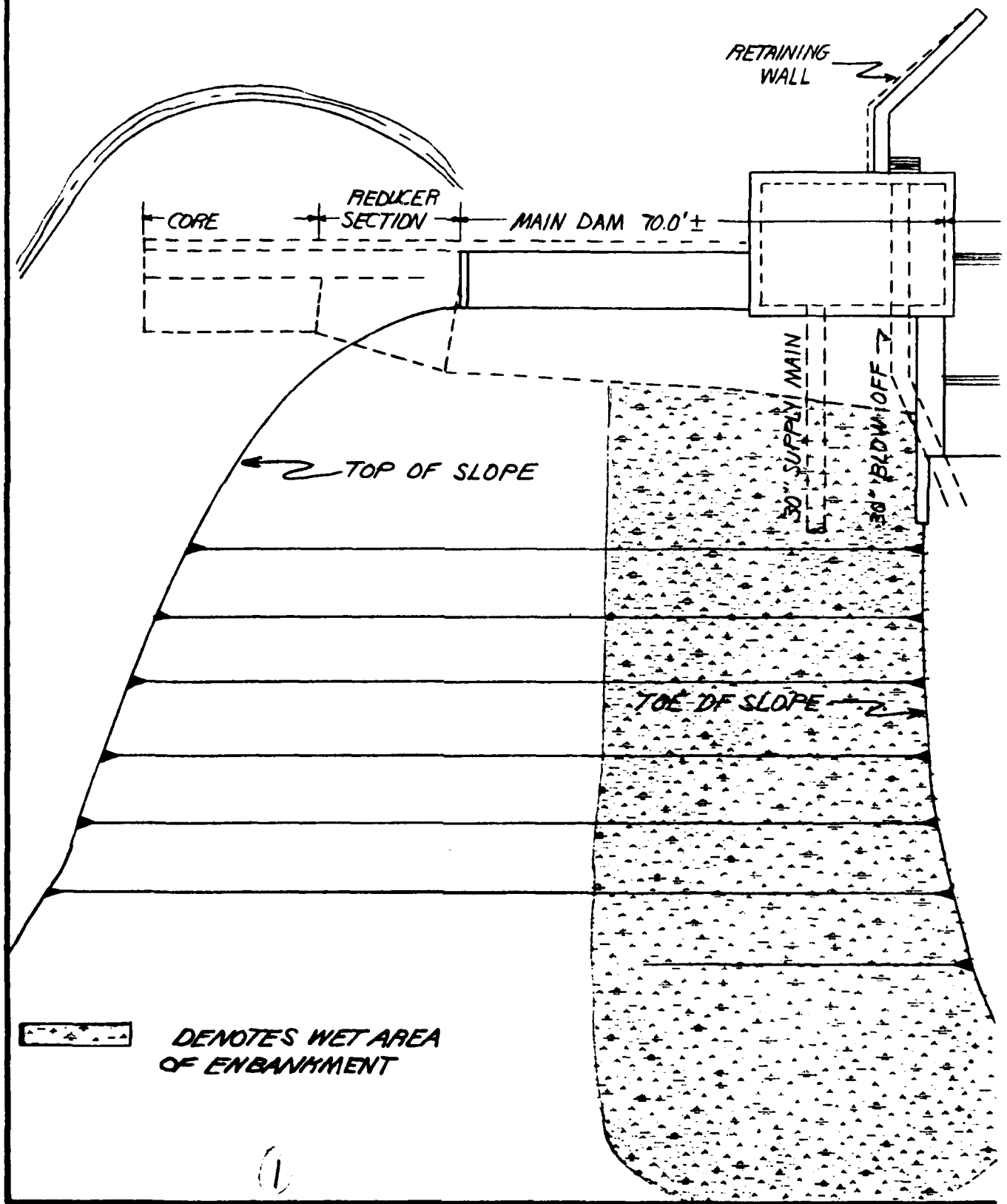

CORE      REDUCER SECTION      MAIN DAM 70.0'±

RETAINING WALL

TOP OF SLOPE

50' SUPPLY MAIN  
30' BYPASS OFF

TOE OF SLOPE

 DENOTES WET AREA OF ENBANKMENT

(1)

# BROAD BROOK RESERVOIR

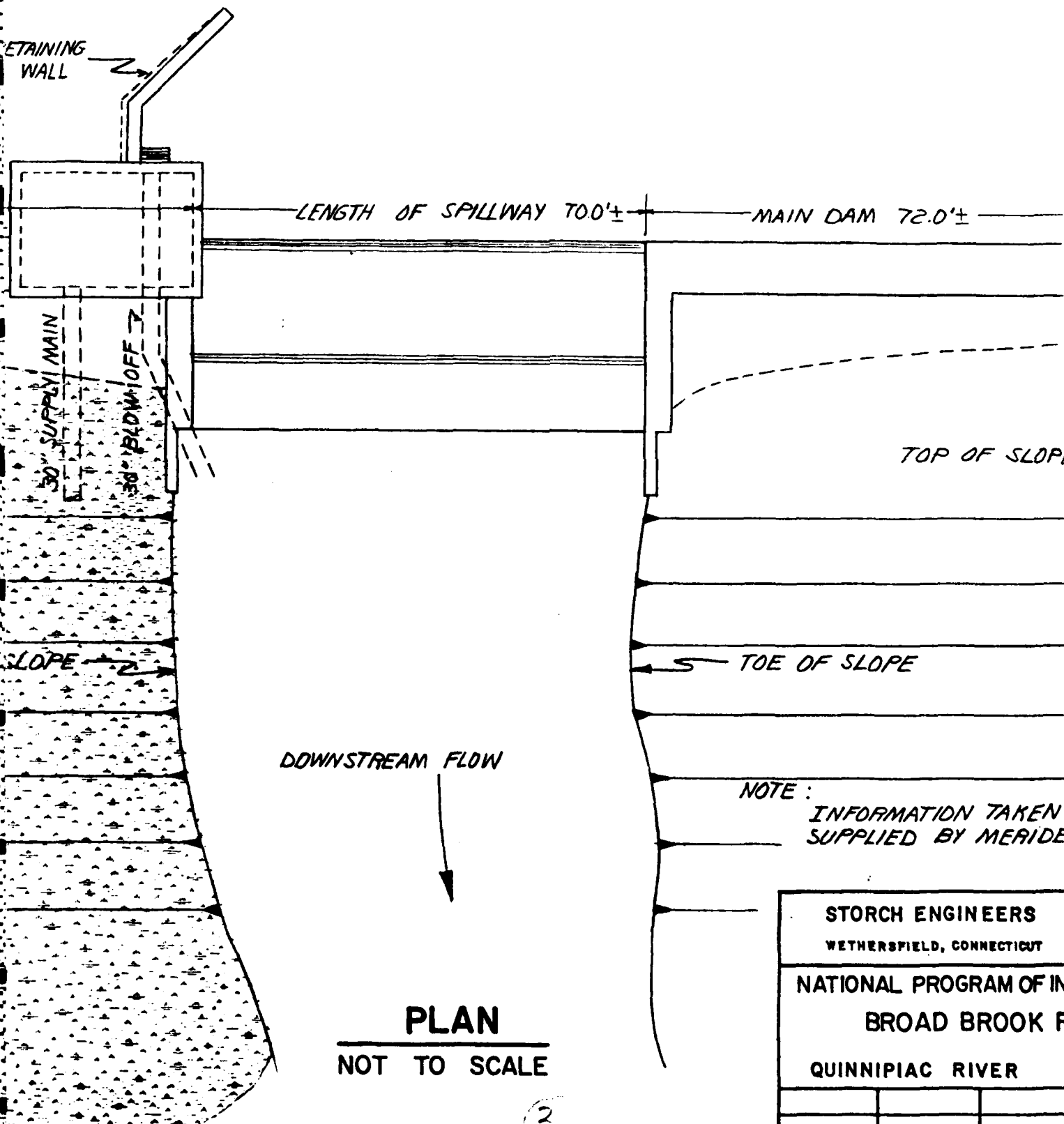

NOTE :  
INFORMATION TAKEN  
SUPPLIED BY MERIDE

STORCH ENGINEERS  
WETHERSFIELD, CONNECTICUT

NATIONAL PROGRAM OF IN  
BROAD BROOK F  
QUINNIPIAC RIVER

**PLAN**  
NOT TO SCALE

RESERVOIR

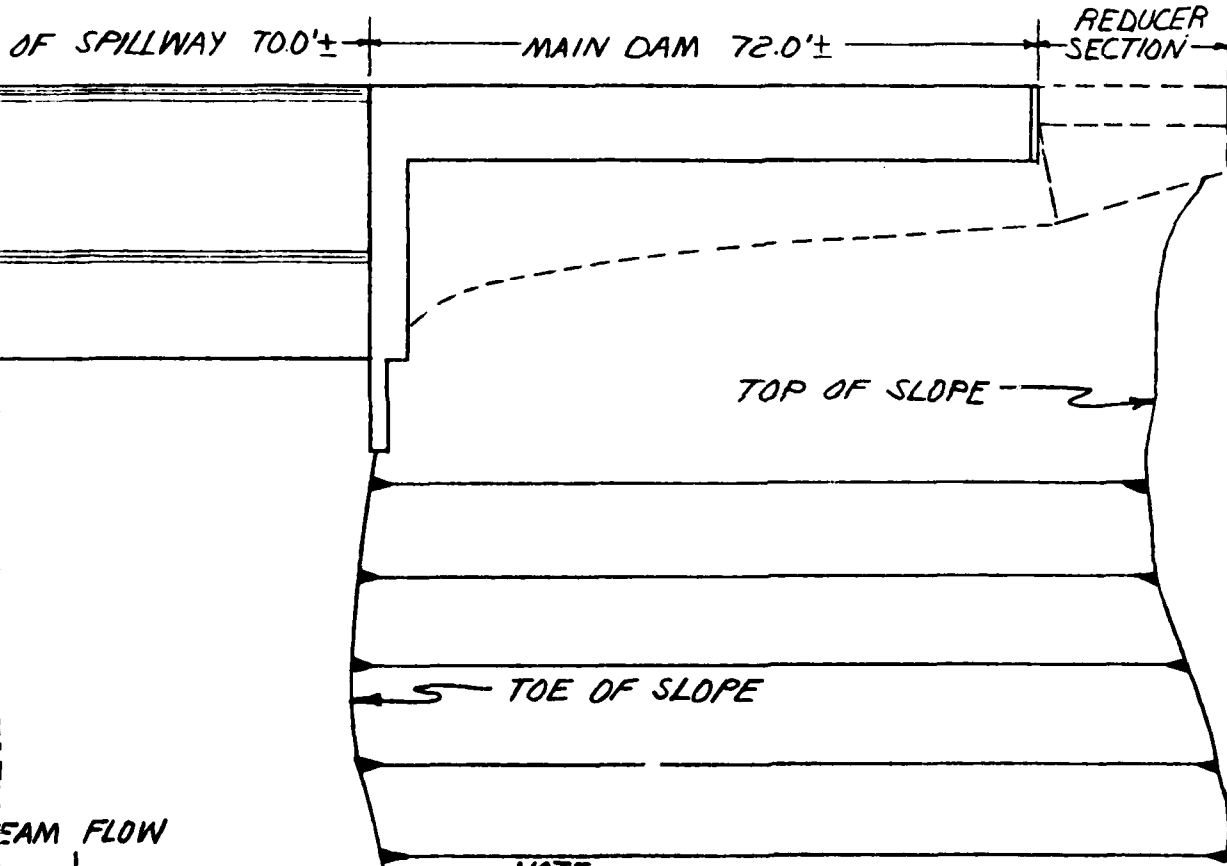

NOTE :  
 INFORMATION TAKEN FROM DRAWINGS  
 SUPPLIED BY MERIDEN WATER DEPT.

PLATE-1

STORCH ENGINEERS  
 WETHERSFIELD, CONNECTICUT

U.S. ARMY ENGINEER DIV. NEW ENGLAND  
 CORPS OF ENGINEERS  
 WALTHAM, MASS.

NATIONAL PROGRAM OF INSPECTION OF NON-FED. DAMS  
 BROAD BROOK RESERVOIR DAM

QUINNIPIAC RIVER

CONNECTICUT

PLAN

TO SCALE

SCALE: AS SHOWN

DATE : AUGUST 1978

(3)

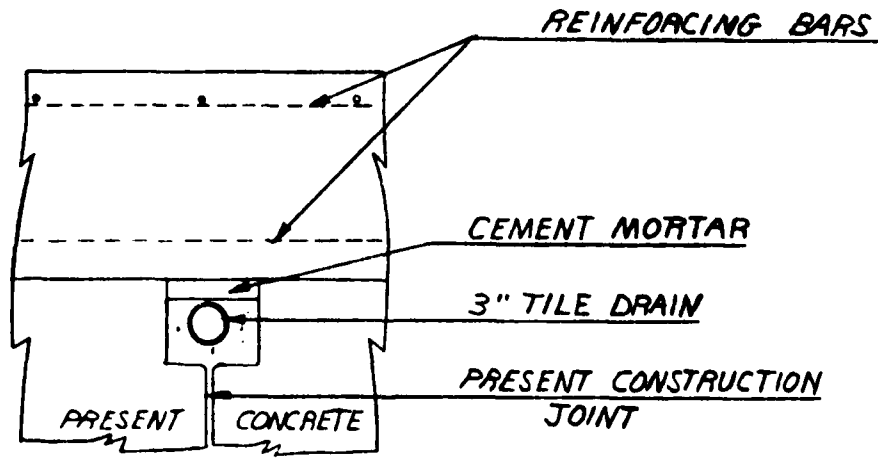
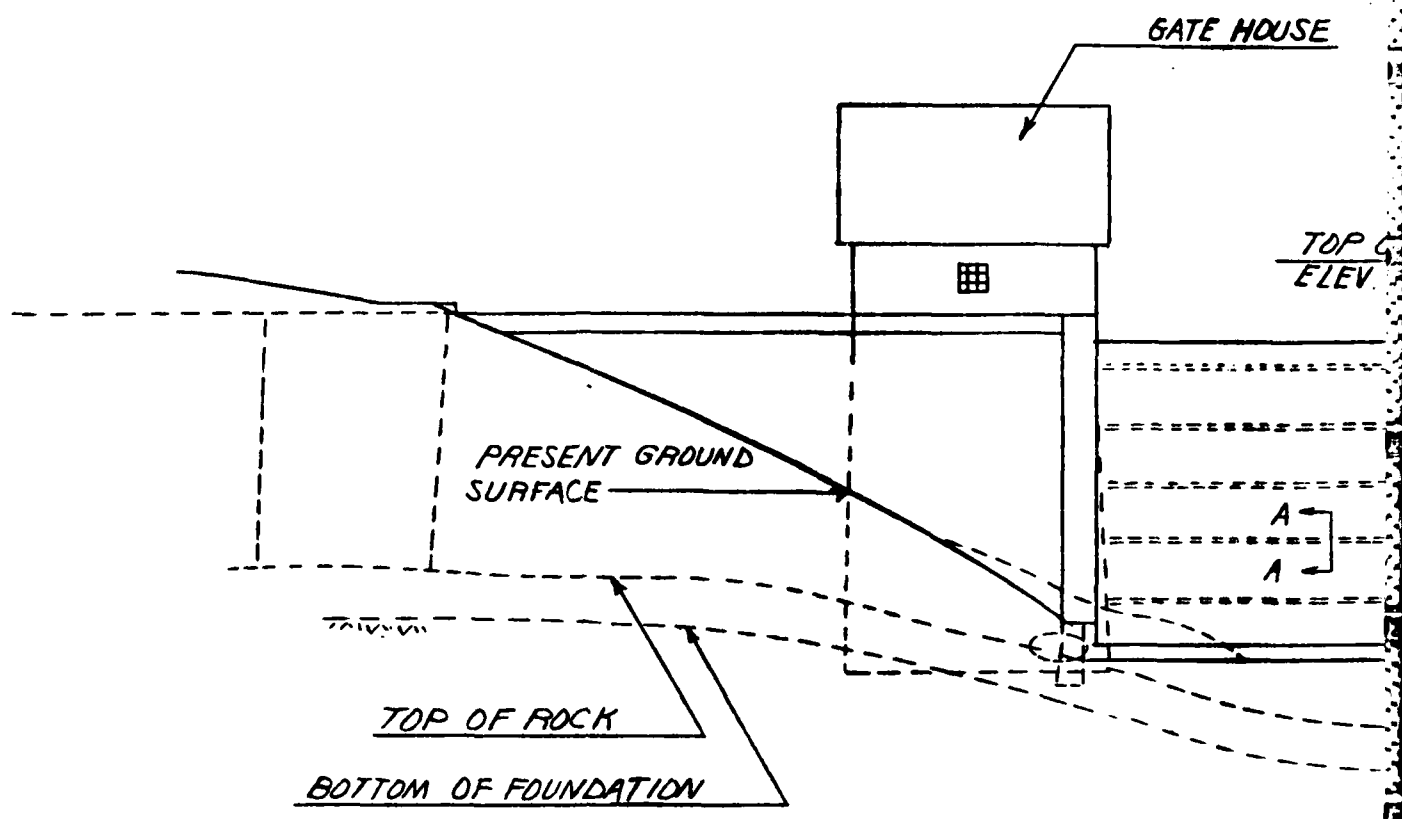

SECTION A-A

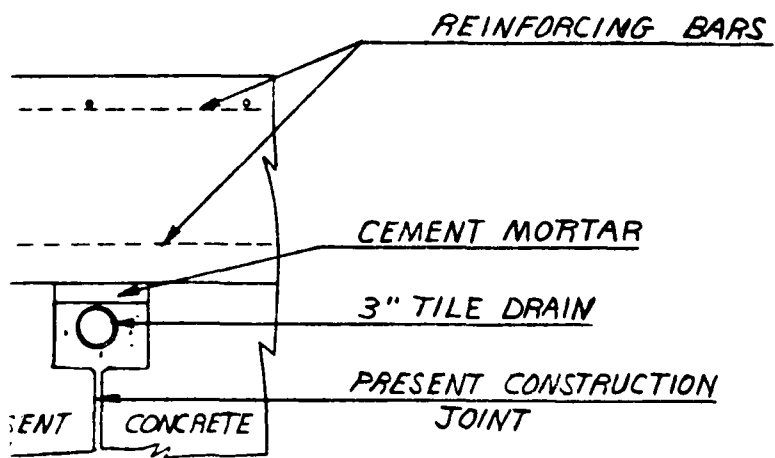
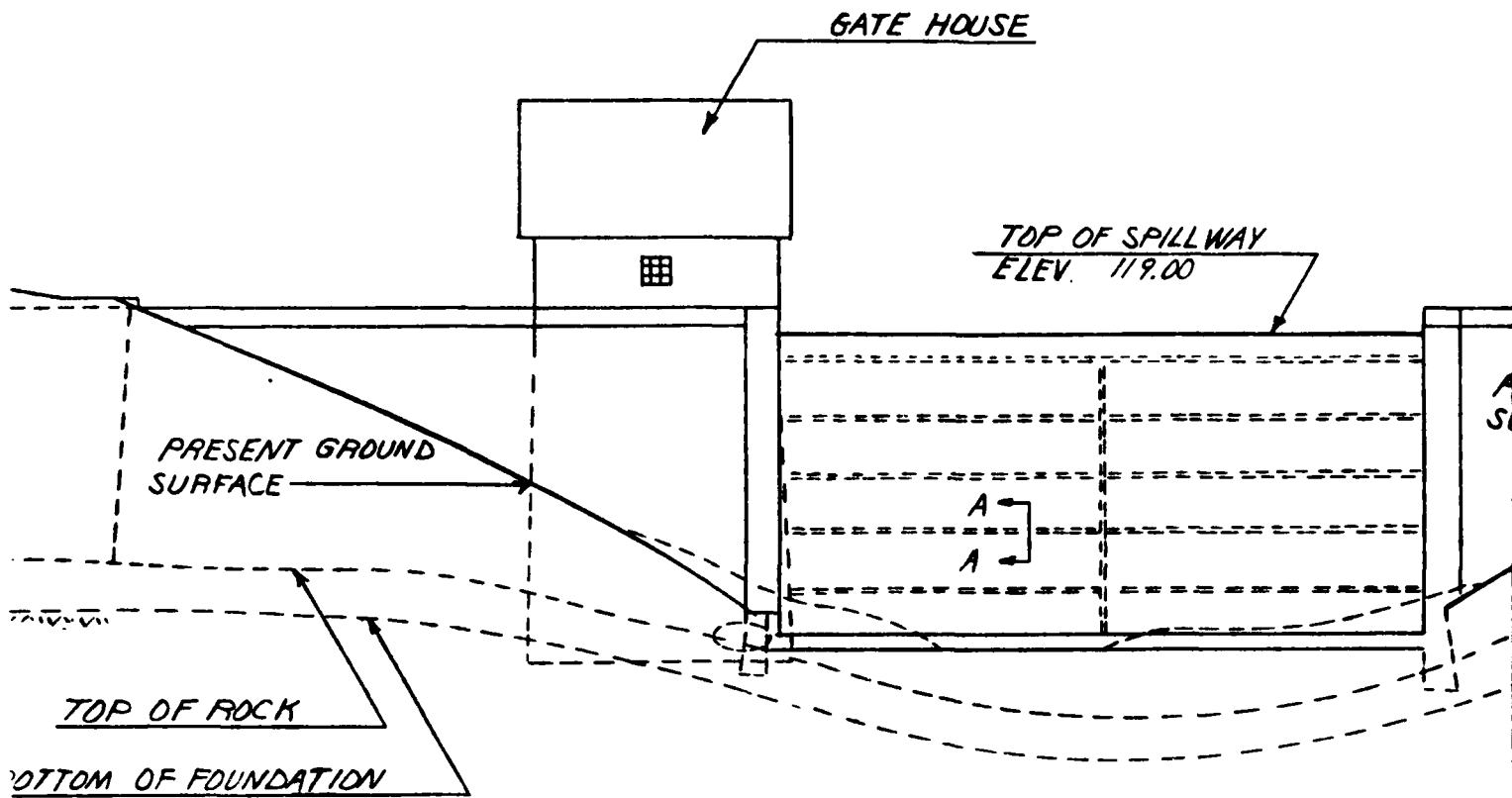

ELEVATION  
NOT TO SCALE

SECTION A-A

2)

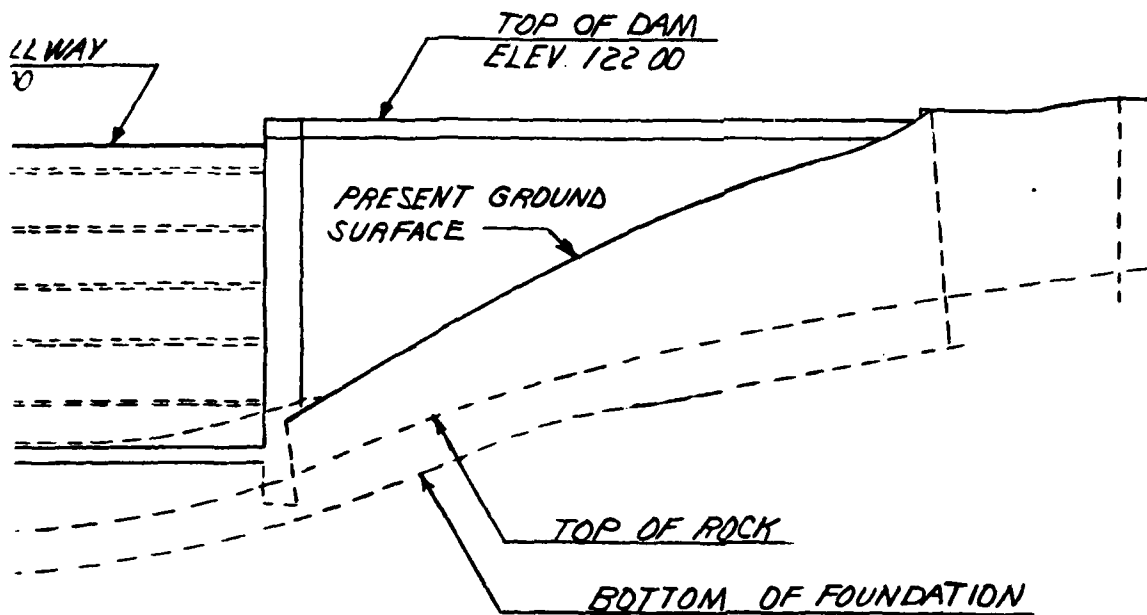

DN  
ALE

NOTE :  
INFORMATION TAKEN FROM DRAWINGS  
SUPPLIED BY MERIDEN WATER DEPT.

PLATE-2

STORCH ENGINEERS WETHERSFIELD, CONNECTICUT		U.S. ARMY ENGINEER DIV. NEW ENGLAND CORPS OF ENGINEERS WALTHAM, MASS.	
NATIONAL PROGRAM OF INSPECTION OF NON-FED. DAMS BROAD BROOK RESERVOIR DAM			
QUINNIPIAC RIVER		CONNECTICUT	
		SCALE: AS SHOWN	
		DATE: AUGUST 1978	

3

TOP OF DAM EL 122

REINFORCEMENT

RESTORED CONCRETE SURFACE (1927)

ANCHORS (TYP.)

APPROXIMATE DOWNSTREAM WATER SURFACE EL 87.7

EXISTING GROUND

30.5' ±

SPILL

NOT

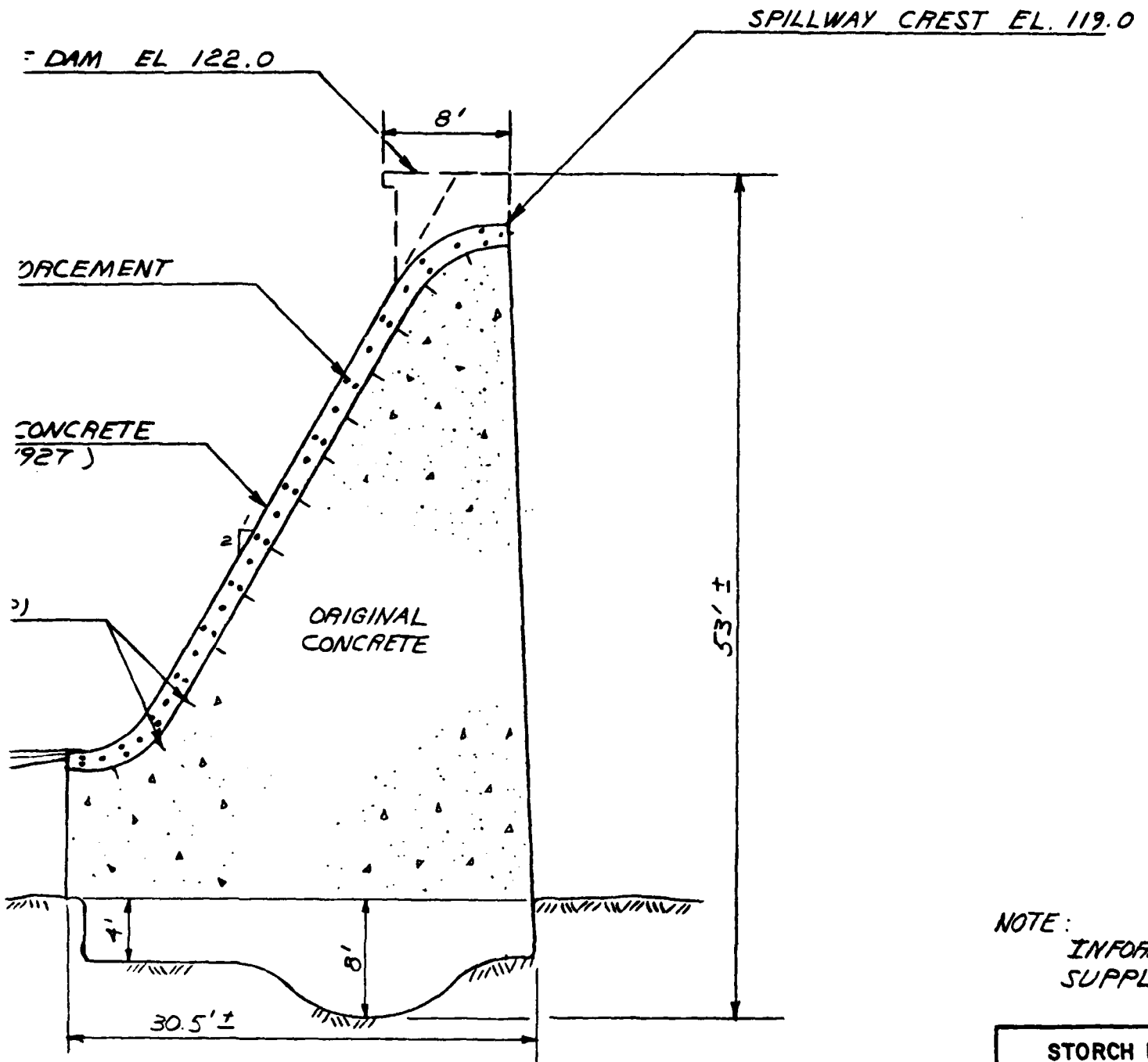

NOTE:  
 INFORMATION  
 SUPPLIED

**SPILLWAY SECTION**

NOT TO SCALE

STORCH ENG	
WETHERSFIELD,	
NATIONAL PRO	
BROAD	
QUINNIPIAC	

2

SPILLWAY CREST EL. 119.0

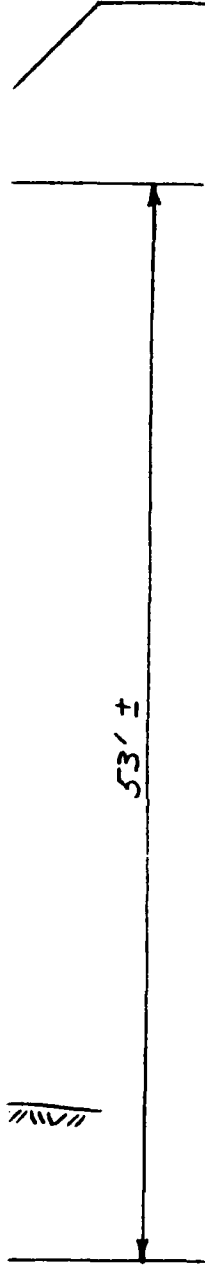

NOTE:  
INFORMATION TAKEN FROM DRAWINGS  
SUPPLIED BY MERIDEN WATER DEPT.

PLATE-3

STORCH ENGINEERS WETHERSFIELD, CONNECTICUT		U.S. ARMY ENGINEER DIV. NEW ENGLAND CORPS OF ENGINEERS WALTHAM, MASS.	
NATIONAL PROGRAM OF INSPECTION OF NON-FED. DAMS BROAD BROOK RESERVOIR DAM			
QUINNIPIAC RIVER		CONNECTICUT	
		SCALE: AS SHOWN	
		DATE: AUGUST 1978	

3

APPENDIX C

PHOTO LOCATION PLAN

PHOTOGRAPHS

Plate 4

II-1 to II-4

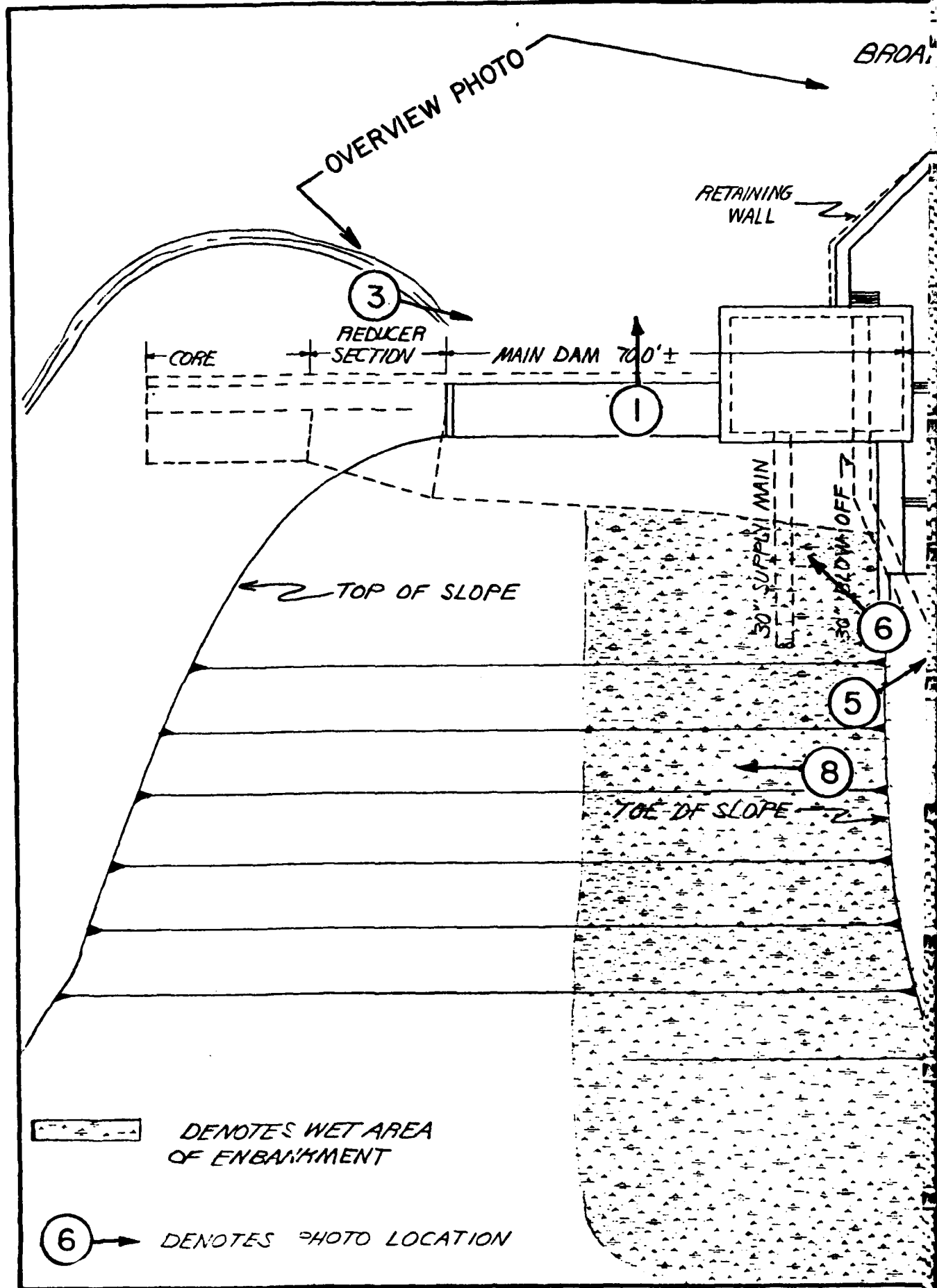
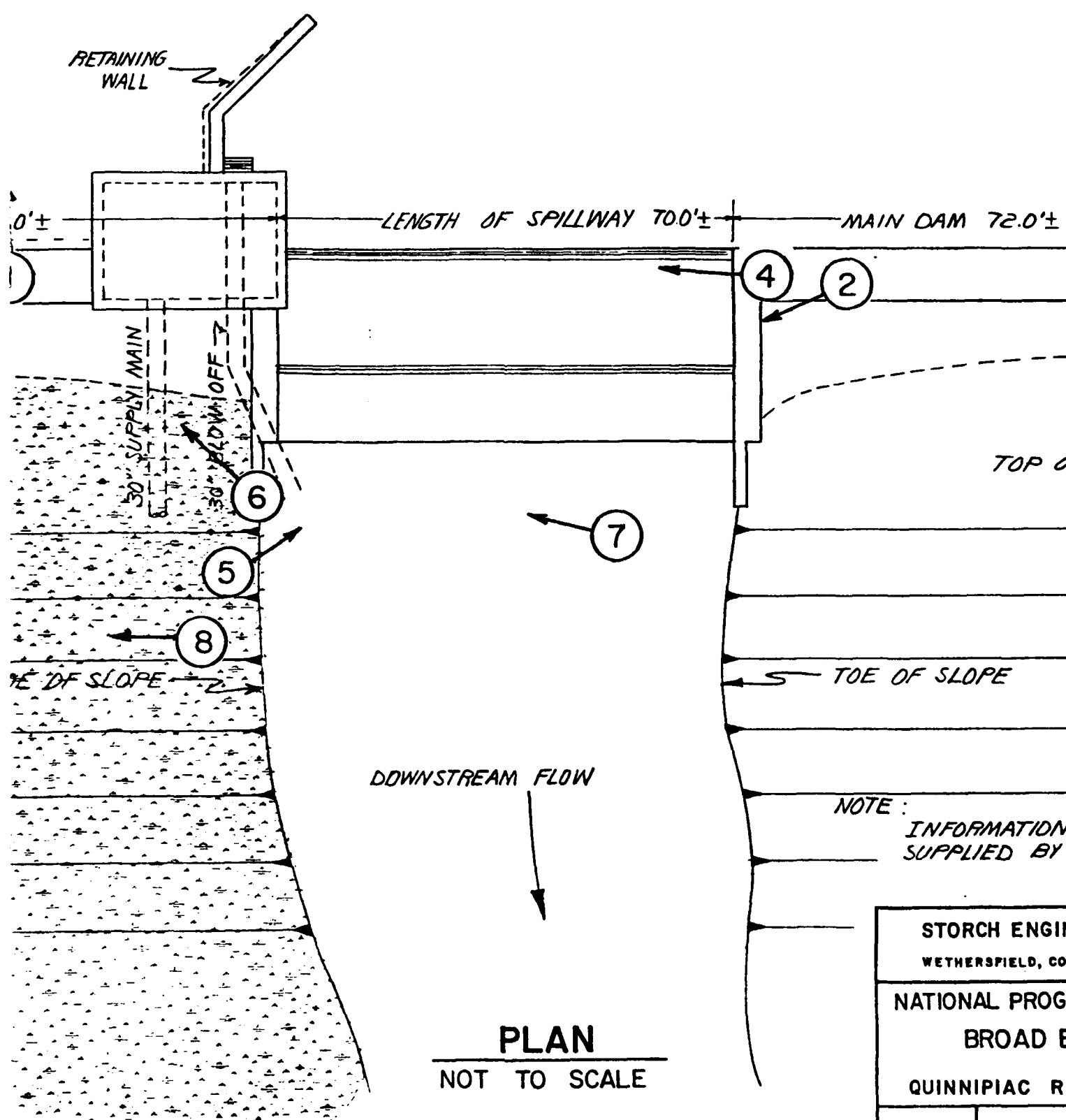

PLATE 1

①

BROAD BROOK RESERVOIR



NOTE: INFORMATION SUPPLIED BY

STORCH ENGINEERING	
WETHERSFIELD, CONNECTICUT	
NATIONAL PROJECT	
BROAD BROOK	
QUINNIPIAC RIVER	

PLAN  
NOT TO SCALE

2

ERVOIR

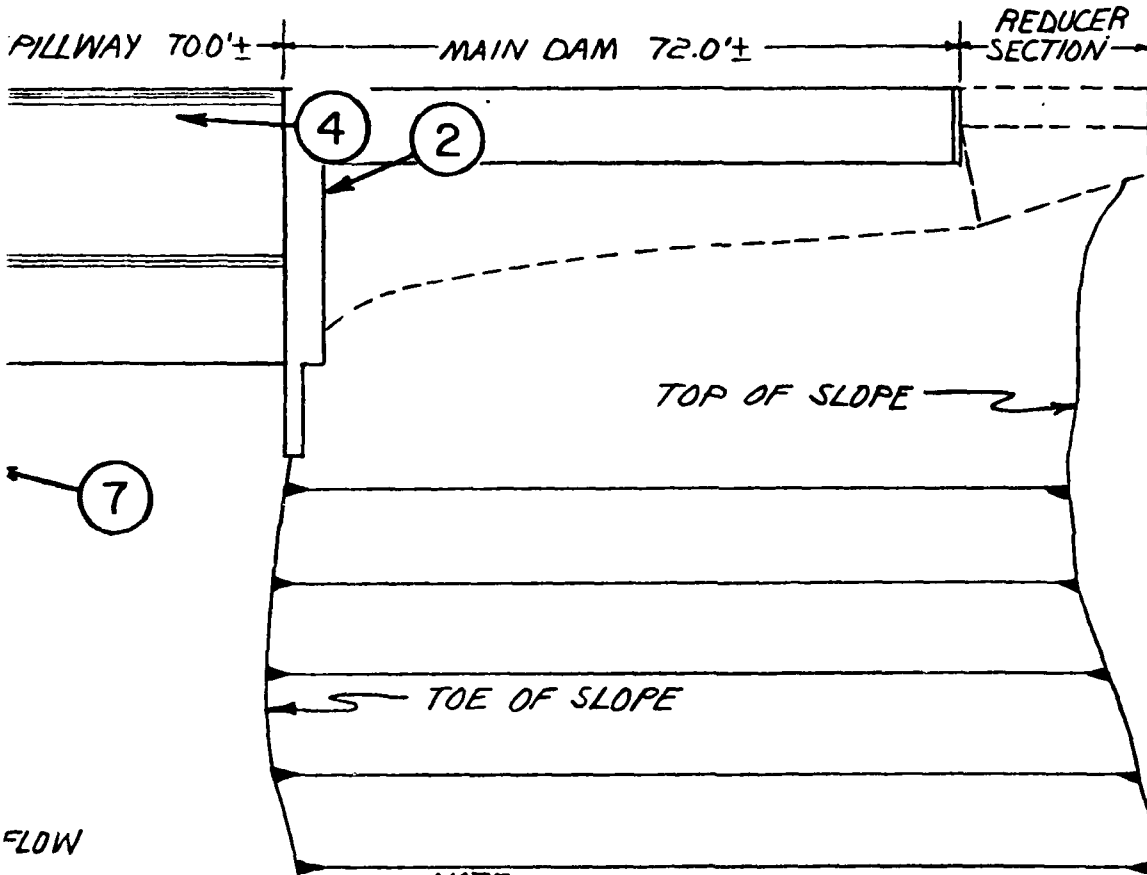
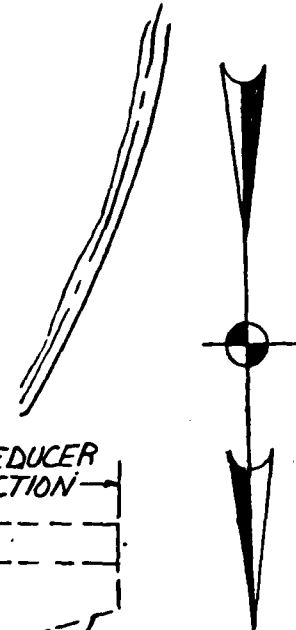

NOTE :  
 INFORMATION TAKEN FROM DRAWINGS  
 SUPPLIED BY MERIDEN WATER DEPT.

PLATE- 4

STORCH ENGINEERS WETHERSFIELD, CONNECTICUT		U.S. ARMY ENGINEER DIV. NEW ENGLAND CORPS OF ENGINEERS WALTHAM, MASS.	
NATIONAL PROGRAM OF INSPECTION OF NON-FED. DAMS BROAD BROOK RESERVOIR DAM			
QUINNIPIAC RIVER		CONNECTICUT	
		SCALE: AS SHOWN	
		DATE : AUGUST 1978	

AN  
SCALE

3 of 3



PHOTO 1  
UPSTREAM RESERVOIR AREA



PHOTO 2  
DOWNSTREAM CHANNEL AREA

II-1



PHOTO 4  
FLASHBOARDS ON CREST OF SPILLWAY



PHOTO 3  
DAMAGE TO UPSTREAM FACE OF DAM



PHOTO 5  
DOWNSTREAM FACE OF SPILLWAY



PHOTO 6  
SEEPAGE FROM FACE OF DAM

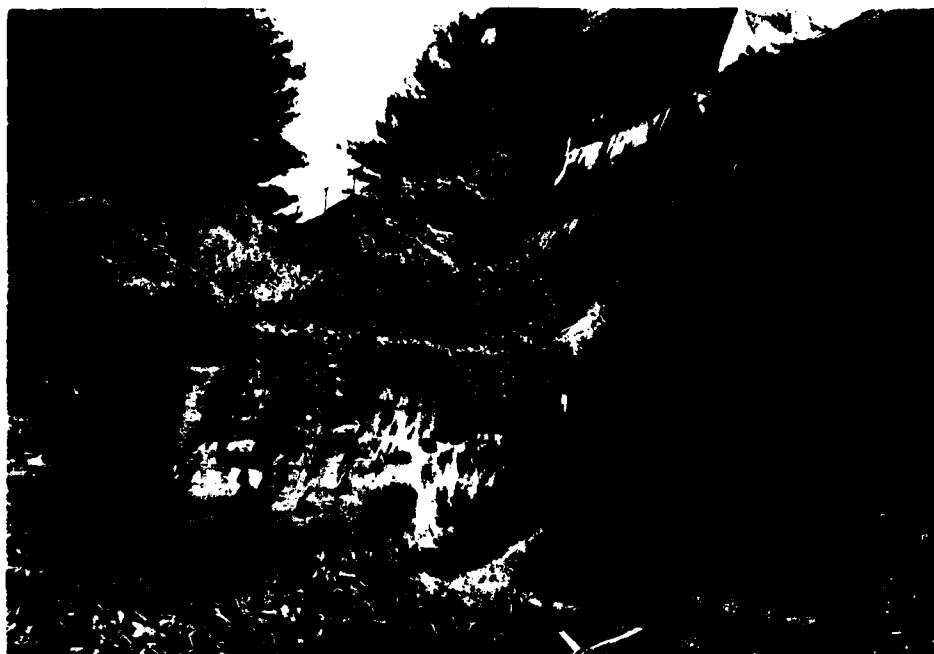

PHOTO 7  
DAMAGE TO EAST FACE OF SPILLWAY AND MAIN DAM

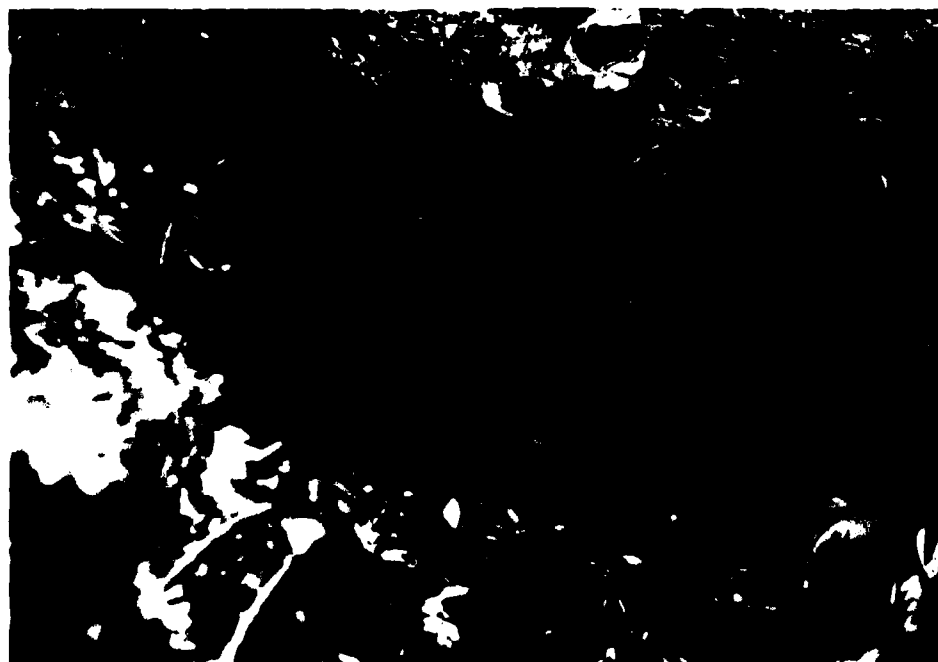

PHOTO 8  
SEEPAGE FROM EAST BANK OF DOWNSTREAM CHANNEL

APPENDIX D

HYDRAULIC COMPUTATIONS      D-1 to D-9

REGIONAL VICINITY MAP        Plate 5

**STORCH ENGINEERS**  
 Engineers - Landscape Architects  
 Planners - Environmental Consultants

**BROAD BROOK RESERVOIR DAM.**  
 STAGE DISCHARGE

SEE PLATES § FOR PLAN § ELEVATION

SPILLWAY				DAM		
H	C	Q	ELEV.	H	Q	
0.0	-	0.0	119.0	0.0	-	0.0
1.0	3.41	240	120.0	0.5	2.70	110
1.5	3.55	457	120.5	1.0	2.68	310
2.0	3.71	735	121.0	1.5	2.65	570
2.5	3.82	1055	121.5	2.0	2.64	870
3.0	3.9	1420	122.0	2.5	2.64	1215
3.5	4.02	1840	122.5	3.0	2.64	1600
4.0	4.09	2290	123.0			
4.5	4.21	2815	123.5			
5.0	4.29	3360	124.0			
5.5	4.33	3910	124.5			
6.0	4.39	4520	125.0			

Flow through water main § blowoff  
 say h = 34' (pond elevation @ spillway crest)

$$Q = CA\sqrt{2gh}$$

$$Q_{\text{blowoff}} = .83(4.9)\sqrt{2(32.2)(34)} = 190 \text{ cfs}$$

$$Q_{\text{water m.}} = .5(4.9)\sqrt{2(32.2)(34)} = 115 \text{ cfs}$$

Total 305 cfs

BROAD BROOK RESERVOIR DAM  
STAGE DISCHARGE

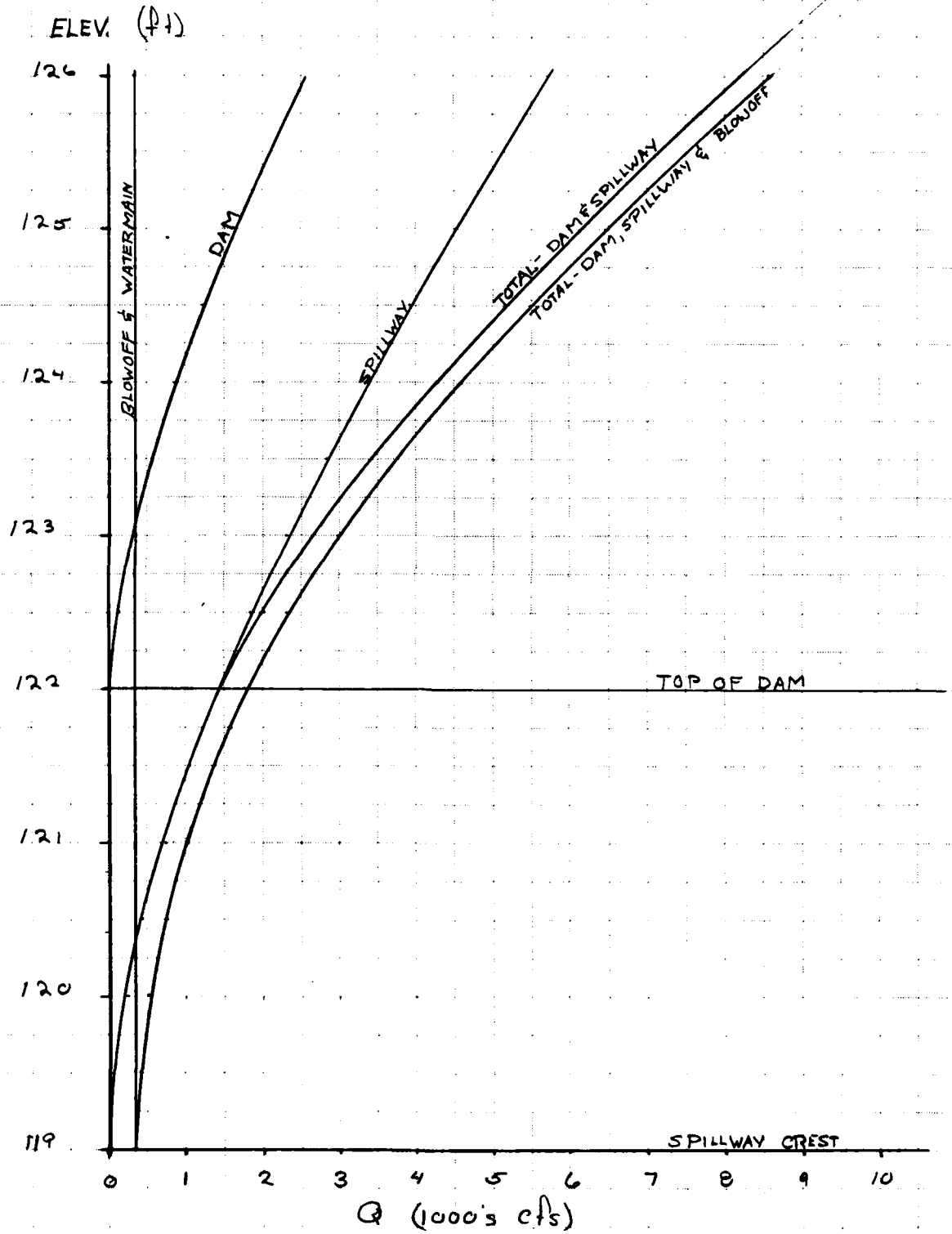

**STORCH ENGINEERS**  
 Engineers - Landscape Architects  
 Planners - Environmental Consultants

BROAD BROOK RESERVOIR DAM  
 AREA - CAPACITY CURVE

ELEV	DEPTH	AREA	AVG AREA	VOL.	ΣVOL (Acre Ft)
85				1.009 BG	0
	34			3097 AcFt	
119		294			3097
	3		358	774	
122		422			3870
	10		505	5050	
132		508			8920

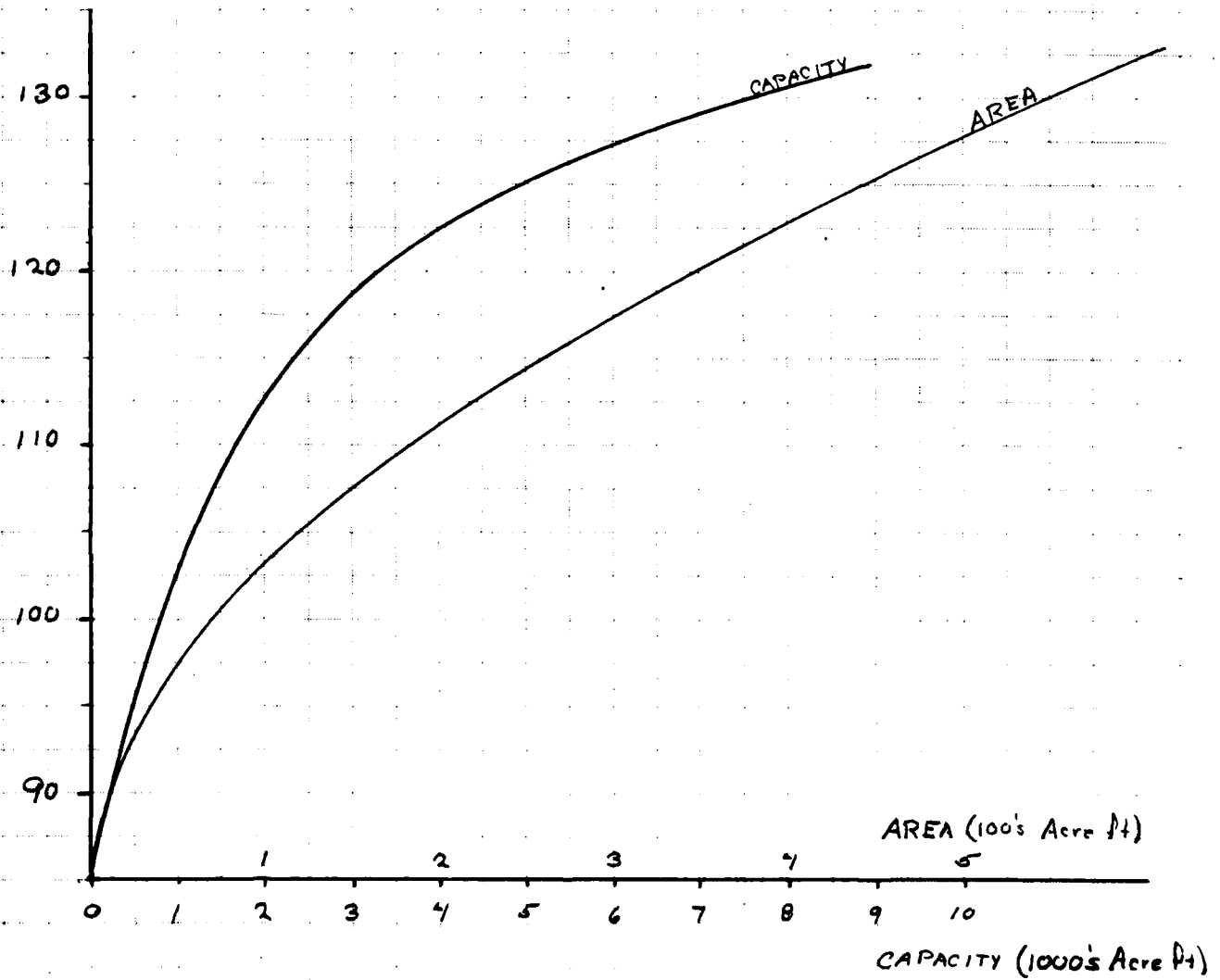

BROAD BROOK RESERVOIR DAM  
DETERMINATION OF SDF & PMF

Drainage Area - 5.0 SM

Inflow (Ref) - 1850 cfs/SM

$$PMF = 5 \times 1850 = 9250 \text{ cfs}$$

Determine the effect of surcharge storage on Maximum Probable Discharge (Ref)

①  $Q_{P1} = 9250 \text{ cfs}$

② a.  $H_1 = 126.5 \text{ (Elev)}$

b.  $STOR_1 = 9.375 \text{ ''}$

c.  $Q_{P2} = Q_{P1} (1 - STOR_1/19) = 9250 (1 - 9.375/19) = 4685 \text{ cfs}$

③ a.  $H_2 = 124.25 \text{ (Elev)}$

$STOR_2 = 6.0 \text{ ''}$

b.  $STOR_{Avg} = 7.69 \text{ ''}$

$Q_{P3} = 9250 (1 - 7.69/19) = 5500 \text{ cfs}$

$H_3 = 126.2 \text{ (Elev)}$

$$PMF = 5500 \text{ cfs}$$

Capacity of Spillway when the pond elevation is @ top of the dam

$$Q = 1450 \text{ cfs} \quad \text{or} \quad 26\% \text{ of PMF}$$

**STORCH ENGINEERS**  
 Engineers - Landscape Architects  
 Planners - Environmental Consultants

BROAD BROOK RESERVOIR DAM  
 SECTION NO. 1 Quinipiac Gorge

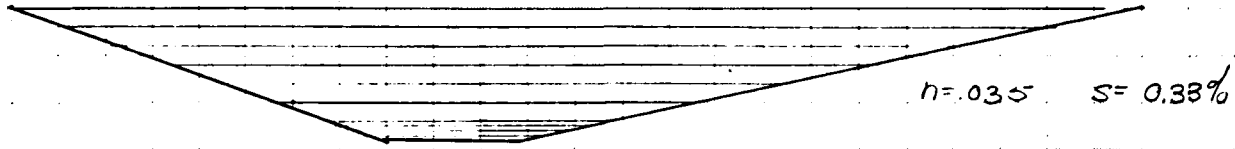

D	W	A	R	$R^{2/3}$	$S^{1/2}$	V	Q
2	82	160	1.95	1.56	0.58	3.87	615
5	110	500	4.5	2.74	0.58	6.74	3370
8	140	920	6.57	3.51	0.58	8.64	7950
10	150	1150	7.67	3.89	0.58	9.58	11012
20	220	2800	12.7	5.5	0.58	13.5	37920
30	300	5400	18.0	6.87	0.58	16.9	91355

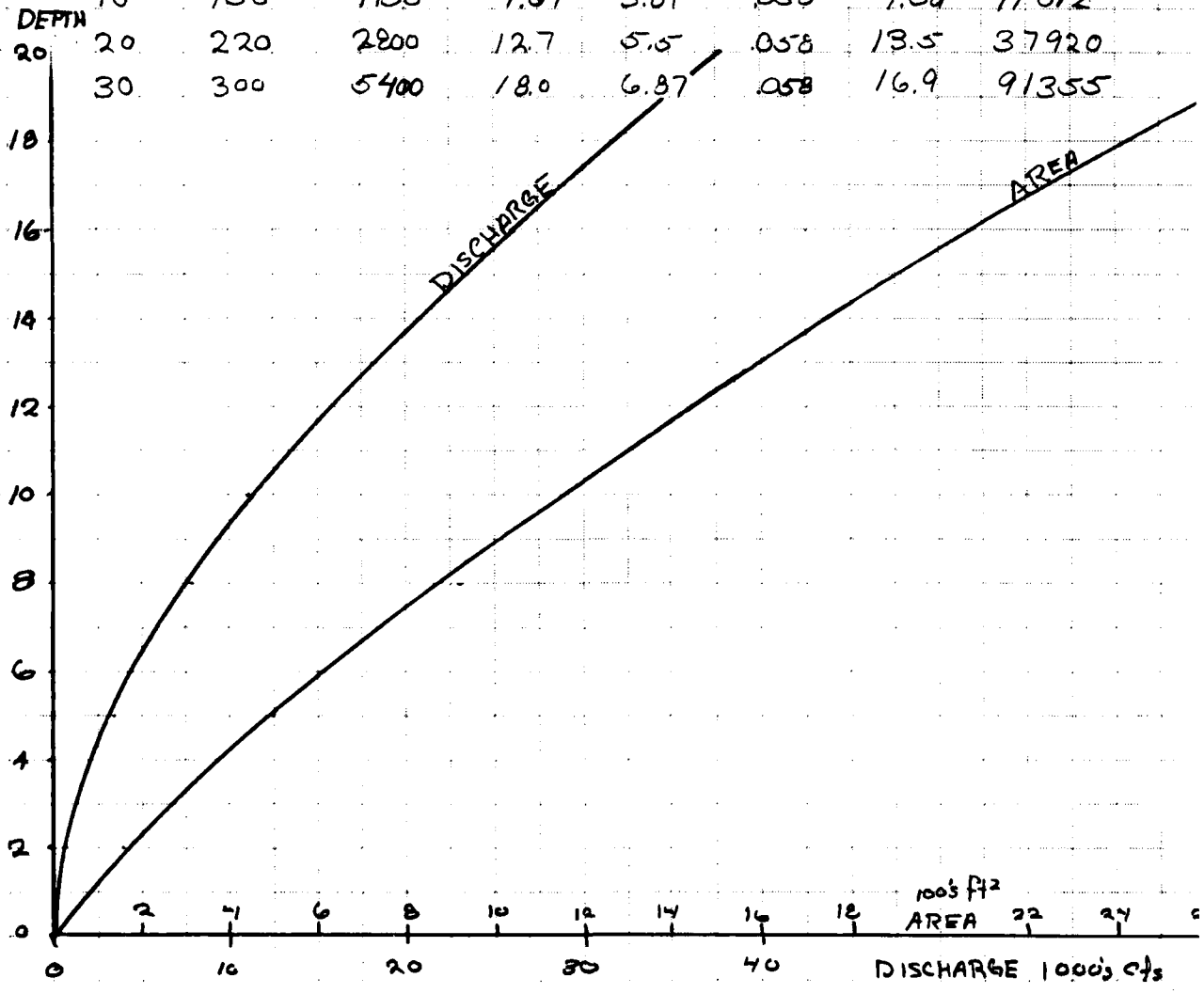

**STORCH ENGINEERS**  
Engineers - Landscape Architects  
Planners - Environmental Consultants

BROAD BROOK RESERVOIR DAM  
SECTION NO. 2 U/S GUINIPAC RIVER

BACKWATER STORAGE ONLY

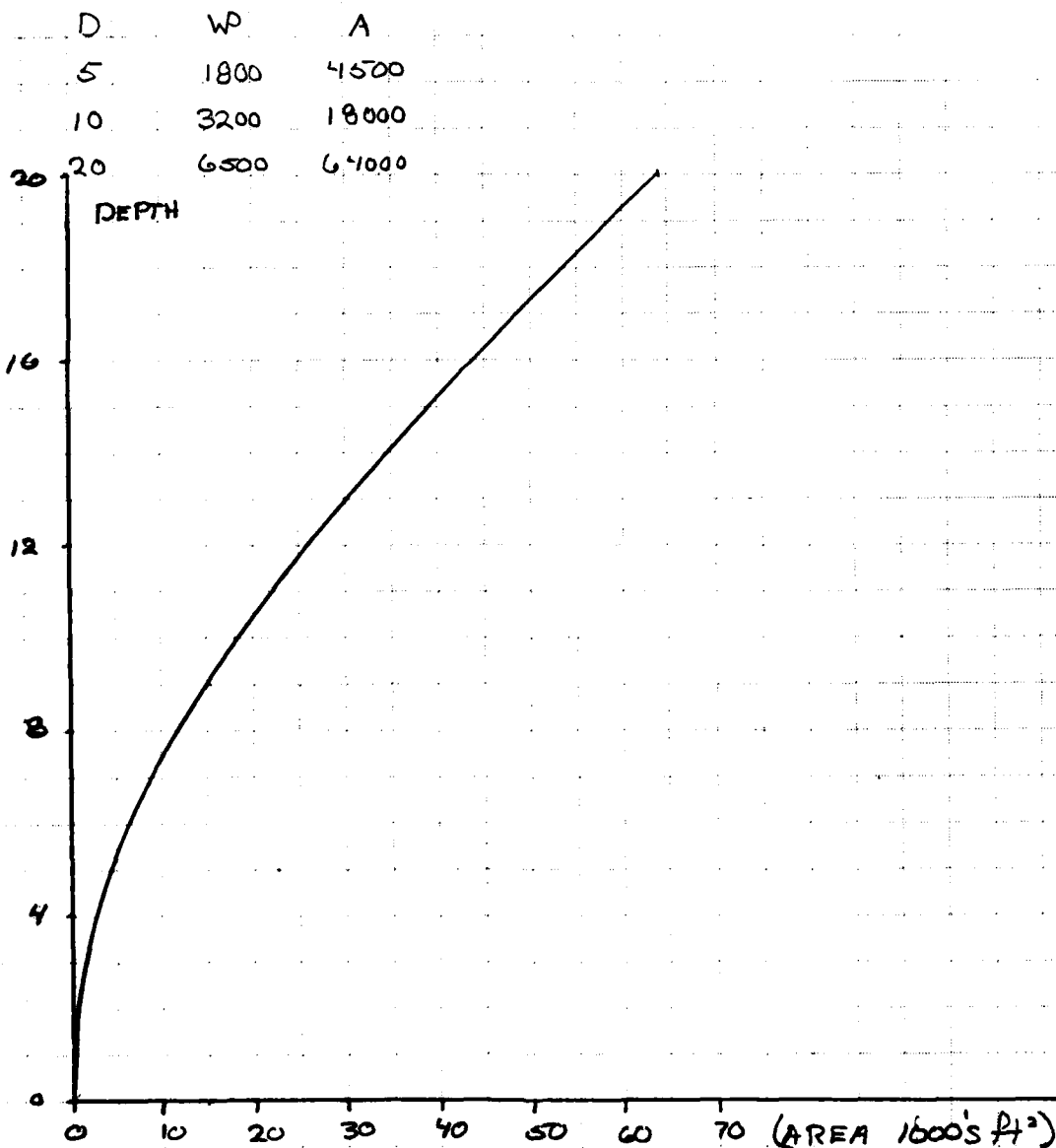

**STORCH ENGINEERS**  
 Engineers - Landscape Architects  
 Planners - Environmental Consultants

BROAD BROOK RESERVOIR DAM  
 SECTION NO 3 D/S QUINPIAC RIVER

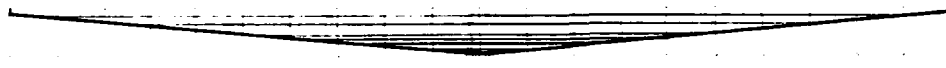

$n = .035$      $s = .08\%$

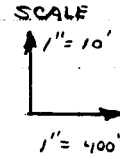

D	W	A	R	$R^{2/3}$	$s^{1/2}$	V	Q
2	200	200	1	1	.028	1.19	240
5	500	1250	2.5	1.87	.028	2.19	2750
8	750	3600	4.8	2.85	.028	3.39	12200
10	900	5000	5.6	3.17	.028	3.73	18660
15	1420	12000	8.45	4.15	.028	4.93	59200
20	1800	19000	10.6	4.8	.028	5.7	108420

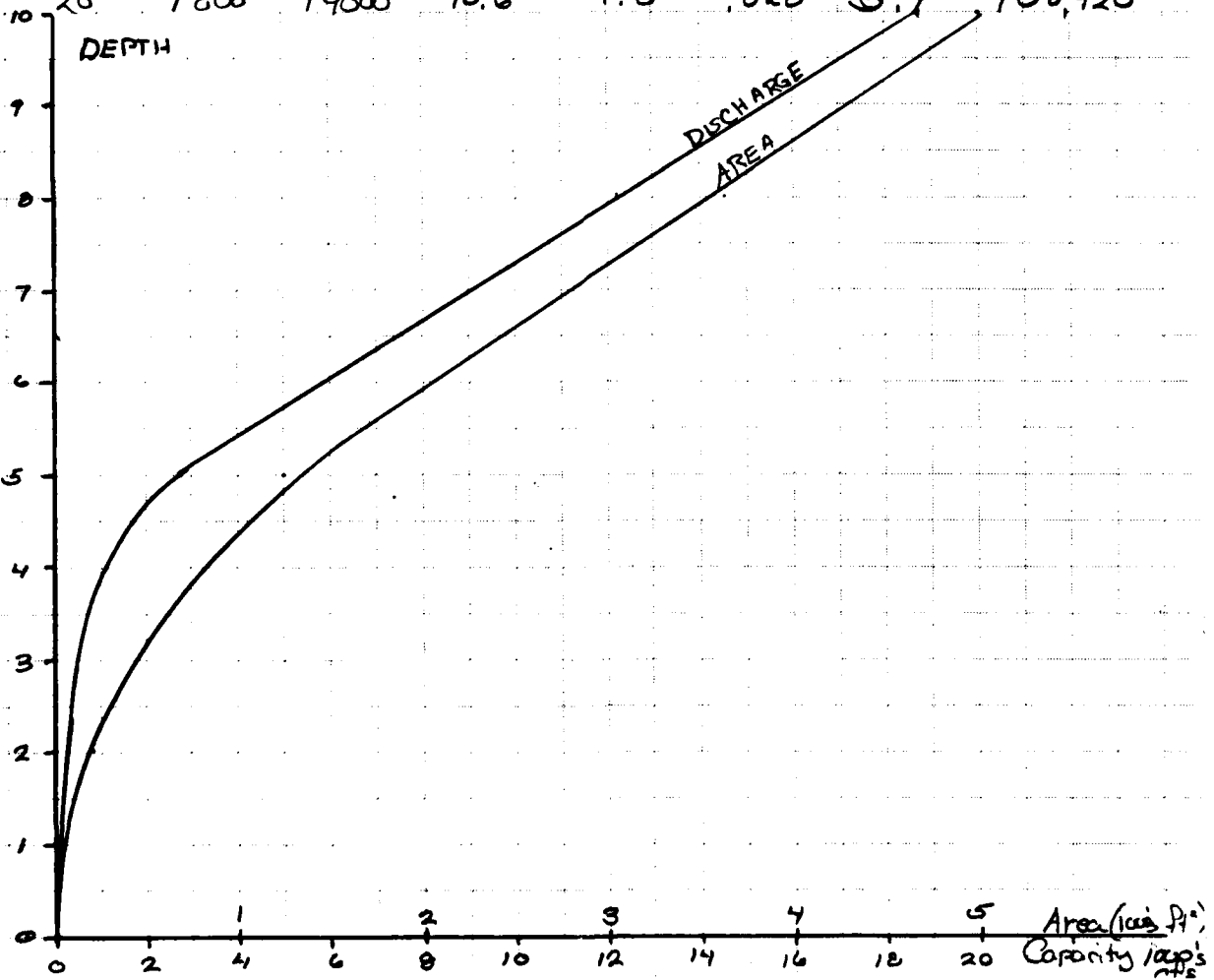

"RULE OF THUMB" GUIDANCE FOR ESTIMATING DOWNSTREAM DAM  
 FAILURE HYDROGRAPHS

SECTION I @ DAM

①  $S = 3870 \text{ Ac-ft}$

②  $Q_{P1} = 8/27 W_b \sqrt{g} Y^{3/2} = 8/27 (48) \sqrt{32.2} (37)^{3/2} = 18160 \text{ cfs}$

SECTION II @ Quinipiac Gorge

③ See Rating Curve No 1

④ a.  $H_1 = 13' \quad A_1 = 1600 \text{ ft}^2 \quad L = 7500'$

$V_1 = 275 \text{ Ac-ft}$

2400' of backwater u/s  $V = 1650 \text{ Ac-ft}$  (Section No 2)

$V_{11} = 1925 \text{ Ac-ft}$

b.  $Q_{P2} = 18160 (1 - 1925/3870) = 9130 \text{ cfs}$

c.  $H_2 = 9' \quad A_2 = 1000 \text{ ft}^2$

$A_{avg} = 1300 \text{ ft}^2 \quad V_2 = 1050 \text{ Ac-ft}$

$Q_{P2} = 18160 (1 - 1050/3870) = 13232 \text{ cfs}$

$H_2 = 11' \quad A_2 = 1300 \text{ ft}^2$

SECTION III @ Hanover Pond (Rating Curve No. 3)

④ a.  $H_2 = 11.0' \quad A_2 = 3300 \text{ ft}^2 \quad L = 1000'$

$V_2 = 30 \text{ Ac-ft}$

b.  $Q_P = 13230 (1 - 30/3870) = 13130 \text{ cfs}$

c.  $H_3 = 8.25' \quad A_3 = 3700 \text{ ft}^2$

$A_{avg} = 2500 \text{ ft}^2 \quad V_{avg} = 57 \text{ Ac-ft}$

$Q_{P3} = 13230 (1 - 57/3870) = 13000 \text{ cfs}$

$H_3 = 8.2' \quad A_3 = 3650 \text{ ft}^2$

SECTION IV @ Rte 68 Yalesville (Rating Curve No. 3)

④ a.  $H_3 = 8.2' \quad A_3 = 3650 \text{ ft}^2 \quad L = 16000'$

$V_3 = 1340 \text{ Ac-ft}$

b.  $Q_{P4} = 13000 (1 - 1340/3870) = 8500 \text{ cfs}$

c.  $H_4 = 6.75' \quad A_4 = 1600 \text{ ft}^2$

$A_{avg} = 2625 \text{ ft}^2 \quad V_{avg} = 964 \text{ Ac-ft}$

$Q_{P4} = 13000 (1 - 964/3870) = 9760 \text{ cfs}$

$H_4 = 7.25' \quad A_4 = 3000 \text{ ft}^2$

SECTION VI @ Toelles Rd. Quinipiac (Rating Curve Nos)

④ a.  $H_4 = 7.25'$   $A_4 = 3000'$   $L = 26000$

$V_4 = 1790 \text{ Ac-ft}$

b.  $Q_{P5} = 9760 (1 - 1790/3870) = 5250 \text{ cfs}$

c.  $H_5 = 5.75'$   $A_5 = 1800 \text{ ft}^2$

$A_{\text{avg}} = 2400 \text{ ft}^2$   $V_{\text{avg}} = 1430 \text{ Ac-ft}$

$Q_{P5} = 9760 (1 - 1430/3870) = 6150 \text{ cfs}$

$H_5 = 6.1'$

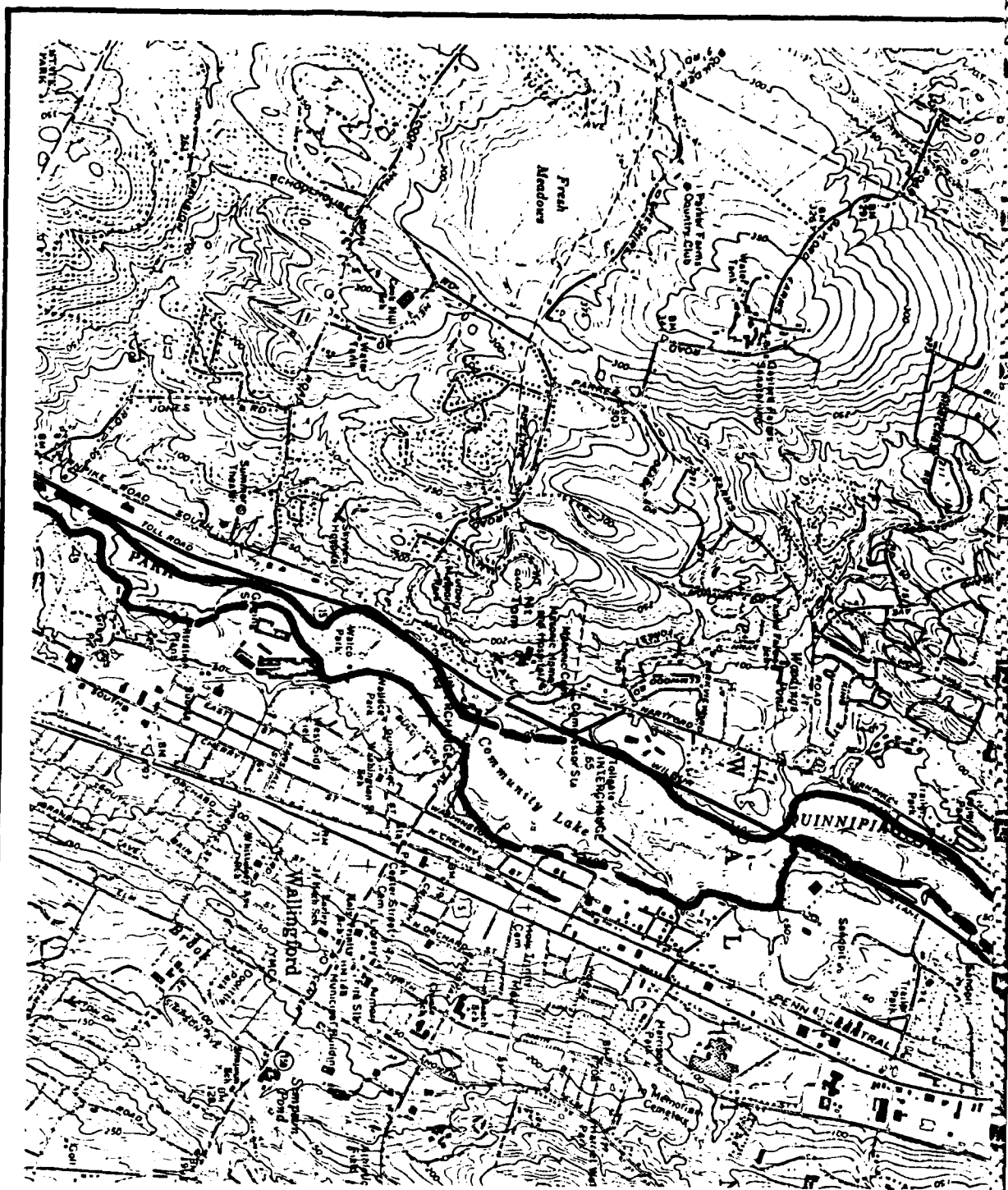

REGI

LEGEND

————— DENOTES LIMITS OF FLOODING  
IN CASE OF DAM FAILURE

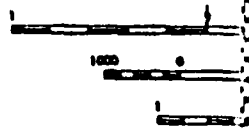
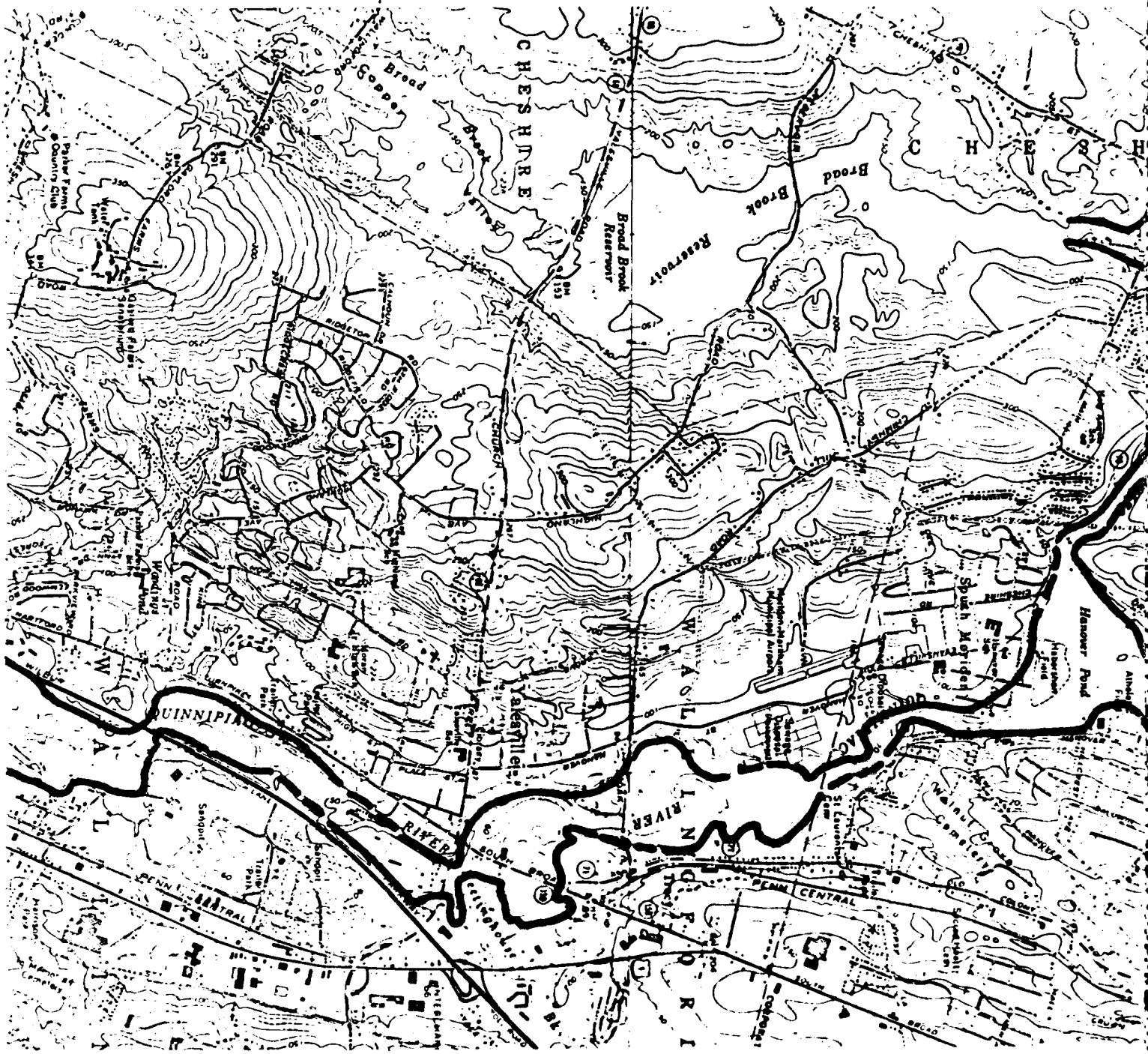
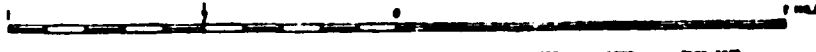

PLATE 5 (1)



REGIONAL VICINITY MAP

SCALE 1:24000



CONTOUR INTERVAL 10 FEET  
DATUM IS MEAN SEA LEVEL

ODING

STORCH
WETHERS
NATIONAL
BR
QUINNIP

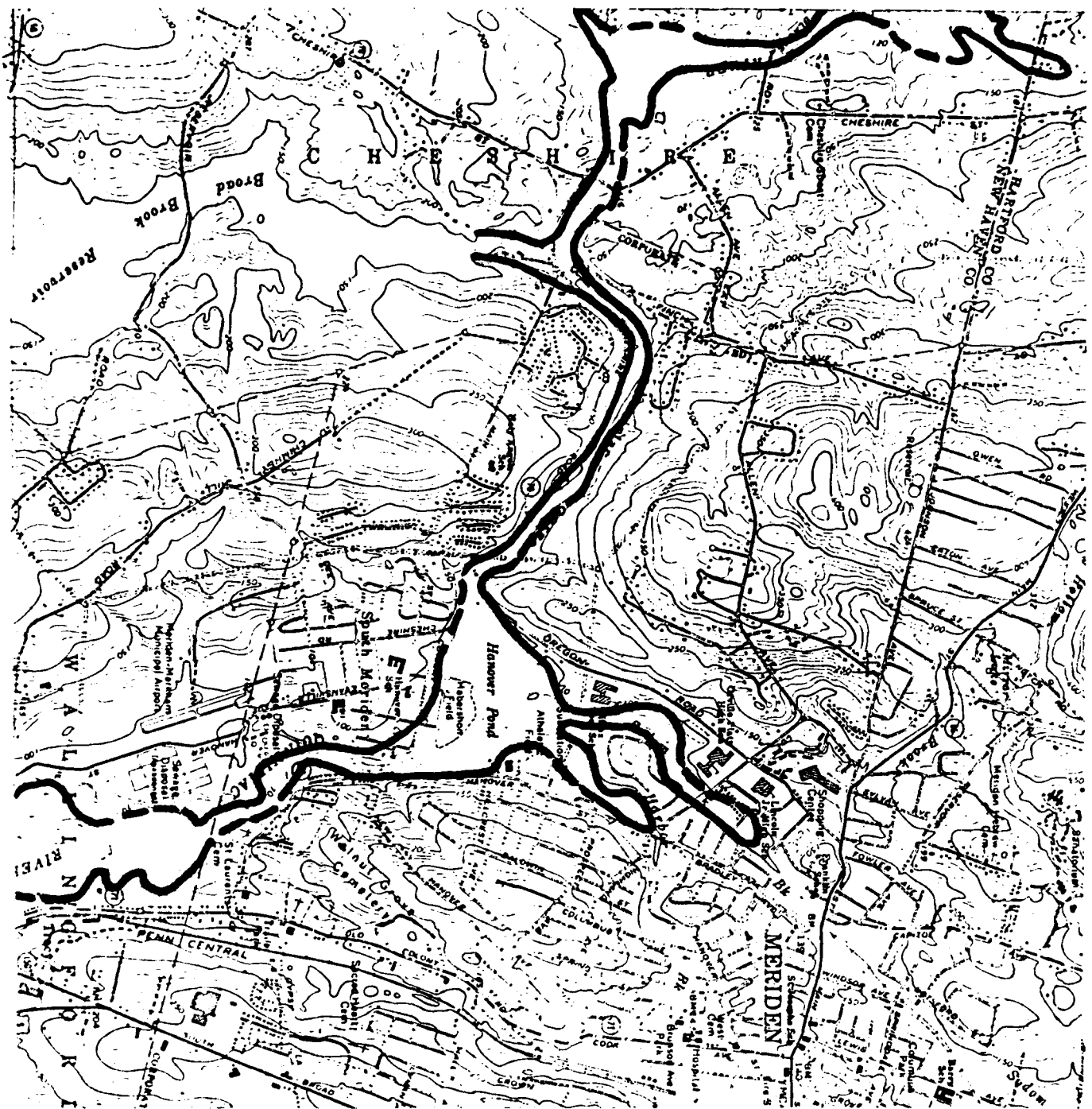
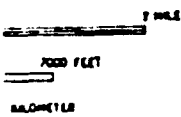

PLATE - 5

AP



STORCH ENGINEERS WETHERSFIELD, CONNECTICUT		U.S. ARMY ENGINEER DIV. NEW ENGLAND CORPS OF ENGINEERS WALTHAM, MASS.	
NATIONAL PROGRAM OF INSPECTION OF NON-FED. DAMS BROAD BROOK RESERVOIR DAM			
QUINNIPIAC RIVER		<i>3 of 3</i>	CONNECTICUT
		SCALE: AS SHOWN	
		DATE: AUGUST 1978	

APPENDIX E

INFORMATION AS CONTAINED IN THE NATIONAL  
INVENTORY OF DAMS



**FILME**