

AD-A144 310 INTELLIGENCE AND ELECTRONIC WARFARE (IEW) SUPPORT FOR
THE CORPS(U) NAVAL WAR COLL NEWPORT RI J M COUGHLIN
22 JUN 84

1/1

UNCLASSIFIED

F/G 15/7

NL

END
DATE
FILMED
9 84
DTIC

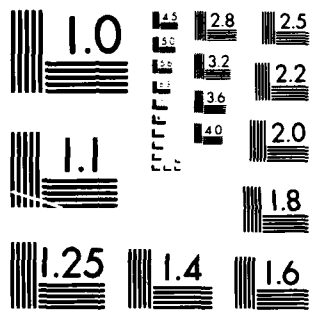

MICROCOPY RESOLUTION TEST CHART
NATIONAL BUREAU OF STANDARDS-1963-A

2

(Unclassified Paper)

NAVAL WAR COLLEGE
Newport, R.I.

INTELLIGENCE AND ELECTRONIC WARFARE (IEW) SUPPORT FOR THE CORPS

by

James M. Coughlin

LTC(P), U.S. Army

A paper submitted to the Faculty of the Naval War College in partial satisfaction of the requirements of the Department of Naval Operations.

The contents of this paper reflect my own personal views and are not necessarily endorsed by the Naval War College or the Department of the Navy.

Signature: James M. Coughlin
30 May 1984

Paper directed by
CAPT Jerome F. Watson
Chairman, Department of Naval Operations
(LCDR George F. Kraus Jr., Staff Intelligence Officer)

Approved by:

George F. Kraus Jr. 30 May 84
Faculty Research Advisor Date

DTIC ELECTE
S AUG 8 1984 D

REPRODUCED AT GOVERNMENT EXPENSE

AD-A144 310

DTIC FILE COPY

DISTRIBUTION STATEMENT A
Approved for public release;
Distribution Unlimited

84 08 07 045

UNCLASSIFIED

SECURITY CLASSIFICATION OF THIS PAGE (When Data Entered)

REPRODUCED AT GOVERNMENT EXPENSE

REPORT DOCUMENTATION PAGE		READ INSTRUCTIONS BEFORE COMPLETING FORM
1. REPORT NUMBER	2. GOVT ACCESSION NO.	3. RECIPIENT'S CATALOG NUMBER
4. TITLE (and Subtitle) INTELLIGENCE AND ELECTRONIC WARFARE (IEW) SUPPORT FOR THE CORPS		5. TYPE OF REPORT & PERIOD COVERED Student Research Paper
		6. PERFORMING ORG. REPORT NUMBER
7. AUTHOR(s) Lieutenant Colonel James M. Coughlin, U.S. Army		8. CONTRACT OR GRANT NUMBER(s)
9. PERFORMING ORGANIZATION NAME AND ADDRESS Naval War College Newport, RI 02841-5010		10. PROGRAM ELEMENT, PROJECT, TASK AREA & WORK UNIT NUMBERS
11. CONTROLLING OFFICE NAME AND ADDRESS Naval Operations Department Naval War College Newport, RI 02841-5010		12. REPORT DATE 22 June 1984
		13. NUMBER OF PAGES 32
14. MONITORING AGENCY NAME & ADDRESS (if different from Controlling Office) Library Department Naval War College Newport, RI 02841-5010		18. SECURITY CLASS. (of this report) UNCLASSIFIED
		19a. DECLASSIFICATION/DOWNGRADING SCHEDULE
16. DISTRIBUTION STATEMENT (of this Report) <i>A - Unlimited</i>		
17. DISTRIBUTION STATEMENT (of the abstract entered in Block 20, if different from Report)		
18. SUPPLEMENTARY NOTES A paper submitted to the Faculty of the Naval War College in partial satisfaction of the requirements of the Department of Naval Operations.		
19. KEY WORDS (Continue on reverse side if necessary and identify by block number) See attached		
20. ABSTRACT (Continue on reverse side if necessary and identify by block number) See attached		

DD FORM 1473 1 JAN 73

EDITION OF 1 NOV 68 IS OBSOLETE
S/N 0102-LF-014-6601

UNCLASSIFIED
SECURITY CLASSIFICATION OF THIS PAGE (When Data Entered)

"INTELLIGENCE AND ELECTRONIC WARFARE (IEW) SUPPORT
FOR THE COEPS"

KEY WORDS

JAMES M. COUGHLIN
LTCOL USA

1. AirLand Battle
2. Area of Influence
3. Area of Interest
4. Combat Electronic Warfare and Intelligence (CEWI)
5. Deep Attack
6. Extended Battlefield
7. Forward Line Of Own Troops (FLOT)
8. Intelligence and Electronic Warfare (IEW)
9. Interdiction
10. North Atlantic Treaty Organization (NATO)

Abstract of

INTELLIGENCE AND ELECTRONIC WARFARE (IEW) SUPPORT FOR THE CORPS

An analysis of the capability of Combat Electronic Warfare and Intelligence (CEWI) units to support the corps and divisions in AirLand Battle is pursued by examining the current structure and equipments fielded. The basic tenets of AirLand Battle -- initiative, agility, depth and synchronization -- are established as valid criteria for evaluating the two structural alternatives presented. The current structure which emphasizes decentralized operations appears to be the better approach given the violence, intensity and confusion that will characterize the modern battlefield. It is concluded that the current CEWI organization has its flaws, centered mostly on equipment and capabilities limitations, but the structure and concept are sound. There are, however, serious equipment limitations that result in gaps in the intelligence capabilities of our forces. Emerging systems under Army 86 will resolve many of the deficiencies but other areas remain to be resolved, including: processing of massive amounts of data, improved Army/USAF cooperation, enhanced survivability of IEW aviation assets, and the development of new aerial platforms.

REPRODUCED AT GOVERNMENT EXPENSE

Abstract of

INTELLIGENCE AND ELECTRONIC WARFARE (IEW) SUPPORT FOR THE CORPS

↙ An analysis of the capability of Combat Electronic Warfare and Intelligence (CEWI) units to support the corps and divisions in AirLand Battle is pursued by examining the current structure and equipments fielded. The basic tenets of AirLand Battle -- initiative, agility, depth and synchronization -- are established as valid criteria for evaluating the two structural alternatives presented. The current structure which emphasizes decentralized operations appears to be the better approach given the violence, intensity and confusion that will characterize the modern battlefield. It is concluded that the current CEWI organization has its flaws, centered mostly on equipment and capabilities limitations, but the structure and concept are sound. There are, however, serious equipment limitations that result in gaps in the intelligence capabilities of our forces. Emerging systems under Army 86 will resolve many of the deficiencies but other areas remain to be resolved, including: processing of massive amounts of data, improved Army/USAF cooperation, enhanced survivability of IEW aviation assets, and the development of new aerial platforms. ↙

Accession For	
NTIS	GRA&I <input checked="" type="checkbox"/>
DTIC	TAB <input type="checkbox"/>
	Unannounced <input type="checkbox"/>
Justification	
By _____	
Distribution/	
Availability Codes	
Dist.	Avail and/or Special
RII	



TABLE OF CONTENTS

CHAPTER		PAGE
	ABSTRACT	11
	LIST OF ILLUSTRATIONS	1v
I	INTRODUCTION	1
	The Problem	1
	AirLand Battle Doctrine	2
II	BACKGROUND OF THE CEWI REORGANIZATION	4
III	IEW FORCE STRUCTURE CONSIDERATIONS	8
	Two Alternatives	8
	Criteria for Evaluation	10
	Conclusion	15
IV	IEW EQUIPMENT AND CAPABILITIES CONSIDERATIONS	16
	The Problem	16
	The Division	18
	The Corps	21
V	CONCLUSIONS	25
	NOTES	27
	BIBLIOGRAPHY	28

REPRODUCED AT GOVERNMENT EXPENSE

LIST OF ILLUSTRATIONS

FIGURE	PAGE
1. MI Group (CEWI) (Corps)	6
2. MI Battalion (CEWI) (Division)	7
3. Corps Areas of Influence and Interest	17
4. Division Areas of Influence and Interest	17
5. IEW Capability: MI Bn (CEWI) (Div)	19
6. Intelligence Assets in the Extended Battle	22

REPRODUCED AT GOVERNMENT EXPENSE

INTELLIGENCE AND ELECTRONIC WARFARE (IEW) SUPPORT FOR THE CORPS

CHAPTER I

INTRODUCTION

The Problem. In the face of present day realities which have forced the military establishment to create forces for new contingencies outside of Central Europe and Northeast Asia, the Army has not relaxed its commitment to its NATO responsibilities. In his White Paper 1980, former Army Chief of Staff, General E.C. Meyer, stated that the "most demanding challenge confronting the U.S. military in the decade of the 1980's is to develop and demonstrate the capability to successfully meet threats to vital U.S. interests outside of Europe without compromising the decisive theater in Central Europe."¹ His view was that "major forces should be directed toward providing separate force packages for NATO and non-NATO contingencies; however, because of the central nature of our NATO commitment, we must ensure that all forces have utility in the NATO environment."² Meyer's comments were not unexpected. For more than 30 years, the security of Western Europe has formed the cornerstone of U.S. defense policy. While recent events cause alarm among those observers who forecast increased threats to U.S. interests beyond Europe, the central "threat to which American Land Power must continue to respond is large-scale conventional war -- the area of greatest Soviet advantage."³ Secretary of Defense, Caspar W. Weinberger, continued this theme in his 1984 Report To Congress by citing a need to check Soviet expansion in the less-developed

world but unequivocally declaring that a "strategy best suited for the center of Europe must be retained."⁴ Increased attention to vital U.S. interests in other areas of the world has not diminished the predominance of NATO in U.S. strategic thinking but it has made the task of structuring a force to meet potential world challenges that much more difficult. Part of the solution adopted is a major feature of the Army's fiscal 1985 program: the creation of what the service's Chief of Staff, General John A. Wickham Jr., called in his budget testimony "elite light infantry divisions" of about 10,000 men each.⁵ But even this new initiative in Army force structuring has had to comply with the NATO utility criterion. Aside from operations in the less-developed world, the new light divisions can be used to reinforce troops already on the ground in Europe. With their improved mobility and decreased deployment time, they better the probability that the U.S. can meet its pledge to bring in six additional divisions, plus their initial support, within ten days. In a warfighting role, light divisions could occupy selected key terrain on the alliance flanks or defend built-up urban areas, where pure infantry forces have more leverage.

Air Land Battle Doctrine. Complementing the Army's innovative force structure has been a new direction in doctrinal thinking as well. Convinced that the primary mission of a land force is to fight and win a land war, Army planners have developed a new doctrine that has particular relevance in Central Europe where the NATO requirement to defeat an attacking enemy is complicated by the growing imbalance favoring the Warsaw Pact. Labeled Air Land Battle, the doctrine provides an alternative for coping with the massive Pact forces

and avoiding the risk of escalation to the use of tactical nuclear weapons. The Air Land Battle concept focuses on interrupting the tempo of the enemy's attack in order to create time and service gaps which our own maneuver forces can exploit. It stresses initiative, agility, depth and synchronization. It differs from the old doctrine of Mobile Defense in the concept of deep attack. Tactical commanders are required to be prepared to attack deep to destroy or disrupt enemy second and follow-on echelons, preventing them from reinforcing the assault echelon. This action would neutralize the enemy's numerical advantage and eliminate his capacity to succeed by concentrating his forces at a place and time of his choosing. Deep attack will support the defeat of the first-echelon divisions and the development of opportunities for decisive counterattacks. Success with Air Land Battle will still require the full range of intelligence and electronic warfare (IEW) support but will now hinge on the ability to "see deep" to isolate critical targets for attack by fire or electronic means. The "see deep" capability will have to be provided by the Combat Electronic Warfare and Intelligence (CEWI) units assigned to the corps and divisions under Army 86 and through interface with echelons above corps (EAC), the U.S. Air Force and national surveillance systems. The question is: Are the CEWI units properly structured and equipped to effectively support tactical commanders and enable them to successfully execute Air Land Battle?

REPRODUCED AT GOVERNMENT EXPENSE

CHAPTER II

BACKGROUND OF THE CEWI REORGANIZATION

"Inherent in the function of destroying the enemy is fixing the enemy. In the past, we have devoted sizable portions of our forces to this requirement. In the future, however, fixing the enemy will become a problem primarily in time rather than space. More specifically, if one knows continually the location of his enemy and has the capacity to mass fire instantly, he need not necessarily fix the enemy in one location with forces on the ground. On the battlefield of the future, enemy forces will be located, tracked and targeted almost instantaneously through the use of data links, computer assisted intelligence evaluation and automated fire control. With first round probabilities approaching certainty, and with surveillance devices that can continually track the enemy, the need for large forces will be less important."

--From an address by General William C. Westmoreland, Chief of Staff U.S. Army, on October 14, 1969, to the Association of the U.S. Army.⁶

The United States learned many lessons from its long and painful involvement in Vietnam. One very poignant lesson was that the intelligence structure of the Army was cumbersome and unresponsive. Army commanders like General Westmoreland knew that success in future wars would require major changes to the tactical intelligence apparatus. With disengagement from Vietnam complete, the U.S. Army initiated a comprehensive study of the problem. Current CEWI organization can trace its origin to 1975 when a major redirection in the force structure of military intelligence units was begun. In September of that year, the Army Chief of Staff approved implementation of certain recommendations of the Intelligence Organization and Stationing Study (IOSS). To that time, the tactical intelligence and electronic

warfare structure was based on doctrine developed to support the Field Army which had been eliminated from the Army force structure. Intelligence and electronic warfare (IEW) units were assigned to parent units at field army and attached to or in direct support of the field army, corps, divisions and ACR/separate brigades. They were not under the command of corps or division commanders which led to major problems in command and control. Tactical commanders were required to turn to a variety of supporting organizations to satisfy their IEW requirements. The system forced corps commanders to rely on eight organizational elements for support.⁷ IOSS combined all-source collection means, production assets and electronic warfare (EW) elements into single IEW organizations, designed to support corps and division commanders as organic elements of their commands. Several key reasons prompted the reorganization. Although signals, imagery and human intelligence had played a major role in the successes realized in Vietnam, post-conflict drawdowns reflected the same perception of a decreased need for intelligence forces that had marked the periods following each previous conflict. Military intelligence units of all types were left understrength and with antiquated equipment in spite of dramatic achievements in electronic and optical technology. In the 1975 time frame, the resources available were insufficient to provide adequate support to the 13 active divisions. Even more alarming, analysis of the 1973 Arab-Israeli War concluded that the Army's military intelligence units were lacking in the necessary equipment and training to fight on a modern, high intensity battlefield. Finally, the trend of DOD Program Budget

REPRODUCED AT GOVERNMENT EXPENSE

Decisions indicated that intelligence resources would suffer even deeper cuts in the upcoming years.

Under current CEWI doctrine, the IEW support mission is performed at corps level primarily by the Military Intelligence Group (CEWI) (Corps). The MI Group provides personnel and equipment for intelligence operations, EW operations and operations security (OPSEC) support. It is organized with a Headquarters and Headquarters Detachment (HHD), an Operations Battalion (OP BN), a Tactical Exploitation Battalion (TEB), and an Aerial Exploitation Battalion (AEB).

FIGURE 1

MI Group (CEWI) (Corps)

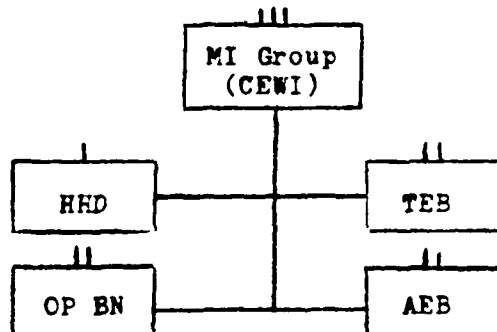

IEW support to the division is similar to that at corps, but is different in scope and emphasis. It is performed at division level primarily by the Military Intelligence Battalion (CEWI) (Division). The battalion is organized with a Headquarters and Headquarters Company (HHC), an Electronic Warfare Company (EW CO), an Intelligence and Surveillance Company (INTEL & SURVL CO), a Service Support Company (SVC SPT CO), and a Military Intelligence Aviation Company

(MI AVN CO).

FIGURE 2

MI Battalion (CEWI) (Division)

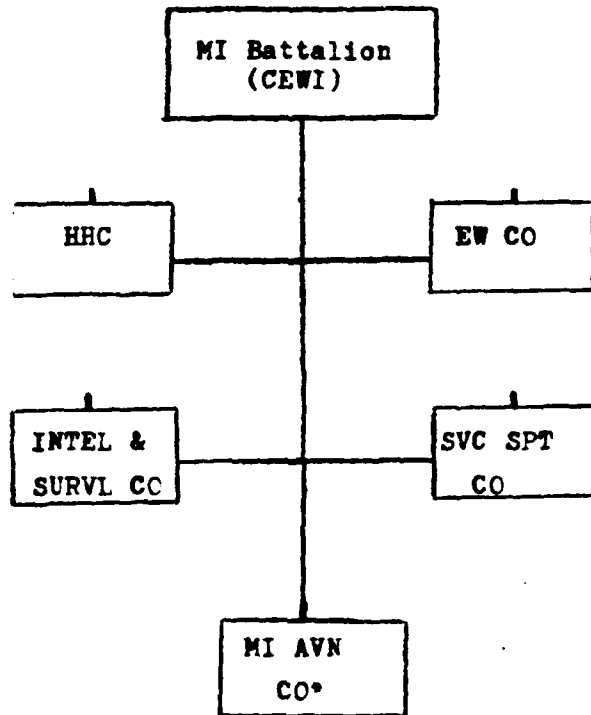

* MI AVN CO assigned to the Air Cavalry Attack Brigade (ACAB), operational control(OPCON) to MI Bn through All-Source Analysis Center (ASAS).

CHAPTER III

IEW FORCE STRUCTURE CONSIDERATIONS

Two Alternatives. With all of the Army's resources being harnessed to support Air Land Battle, it would seem prudent to relook the CEWI force structure that was fashioned at a time when that battlefield doctrine did not exist nor were the resources available to support it. In structuring an intelligence and electronic warfare (IEW) force to support Air Land Battle, I see two reasonable alternatives. The principal discriminator revolves around the centralization/decentralization of control issue. Alternative 1 is the current IEW system. Under that system, a CEWI battalion is assigned to each division and a CEWI group is at each corps. The concept is based on the premise that commanders fighting the battle should direct tactical intelligence efforts. At the division level, the division commander exercises full control of all divisional tactical intelligence resources. CEWI integrates all categories of combat intelligence into a single battalion. It intends that the division have the best intelligence equipment to include new sensor and secure communications systems, improved support vehicles and automated processing capabilities. All tactical intelligence personnel except those assigned to the G-2 and S-2 sections are assigned to the CEWI battalion. Intelligence requirements beyond the capability of divisional systems are passed to corps for satisfaction. A CEWI group is assigned at corps and includes several subordinate battalions that provide all-source intelligence, EW and OPSEC support to the corps and assigned divisions. The corps is generally the first level

of command where information from tactical, echelons above corps (EAC), and national systems are brought together. Secure communications links, some real-time, facilitate the collection management function, the dissemination of intelligence and combat information, and the coordination of IEW support throughout the corps area. Alternative 2 presumes that direction of battlefield intelligence can be better performed at an echelon somewhat removed from the front lines of the battlefield. The corps commander is the key U.S. Army player in fighting the Air Land Battle. He bears the burden of directing the counterattack deep behind enemy lines while also coordinating the main battle in the forward area. With only limited IEW assets available, the corps commander must have the capability to concentrate and shift those resources to "develop rapid and accurate targeting information and intelligence on enemy forces within his area of influence."⁸ Under this alternative, all IEW assets would be consolidated in one organization with command and control at the corps level. Support of divisions and ACRs/separate brigades would be accommodated by task-organizing and attachment to the appropriate element. Redundant IEW activity would be minimized. Economies of scale would result -- assets not specifically earmarked for support of division/brigade operations would remain under control of corps for employment in support of corps priorities. Pools of trained technicians would be available to focus on that information/intelligence that will enable the corps commander to see the battlefield in sufficient time and detail to generate the appropriate combination of maneuver, fire support and EW forces at the right time and place. The modus operandi would be a "push" type system with corps feeding the

REPRODUCED AT GOVERNMENT EXPENSE

intelligence requests of subordinate commanders. Consolidation and centralized control, enhanced by the effects of synergism, would result in more effective support to the overall corps effort.

Criteria For Evaluation. In attempting to establish useable criteria upon which to make a choice of available alternatives, compatibility with the basic tenets of Air Land Battle doctrine -- initiative, depth, agility and synchronization -- seems valid. But also, we should consider how well each alternative would support a commitment of U.S. forces to the wide range of contingencies that could be expected.

Initiative implies an aggressive and offensive spirit in the conduct of all operations. It requires that commanders set the terms for the battle and stay one step ahead of the enemy through bold action and risk taking. Commanders work within the context of the overall plan but do not hesitate to engage in independent action when an unforeseen opportunity presents itself. Quick action and timely decision making keep the enemy off balance and hasten his defeat. The deep attack is launched at the time and place that intelligence reveals the enemy is most vulnerable. Alternative 1 gives both corps and division commanders dedicated IEW resources. At neither level, however, are the resources sufficient to see deep enough into the areas of influence and interest to successfully prosecute Air Land Battle. Even though Army doctrine requires divisions to furnish much of their own support, it is clear that "the division cannot see or interdict electronically as deep as its area of influence extends. In fact, there is only limited division capability to see the enemy's second-echelon regiments, much less a farther

distance."⁹ Currently, the weapons, jammers and sensors at division level makes the area out to about 30 kilometers beyond the FLOT primarily a land battle vice an air battle. Emphasis at division is necessarily rapid collection, processing and reporting of intelligence and targeting information. IEW support beyond 30 kilometers, an area in which the deep attack would be executed, must be provided by corps, EAC or the Air Force. Alternative 2 places all IEW assets under the control of corps. Support of any division operation would be accomplished by task-organizing and attaching that element to the division. Under this concept, it would be possible for corps to attach some of its long-range sensors to give the division a "see deep" capability but it appears unrealistic that the corps commander would be willing to lose control of those assets. As the enemy's intentions become clearer, opportunities for display of initiative will be significantly increased by concentrating IEW resources under control of the affected friendly commander. But the intensity, violence and confusion of the modern battlefield will probably severely restrict free movement of IEW assets throughout the corps area. What IEW forces that are attached to a division at the start of hostilities will probably remain constant, minus combat losses, for the duration of the battle. The advantage to be gained by a corps commander who can attach and detach as the battle picture changes would most likely never be realized. In fact, attempted redeployment in the midst of crippled or disrupted command and control systems could result in an overall reduced IEW capability. Initiative will be exercised more readily by the commander who has confidence in the abilities of the forces under his control.

The CEWI battalion is currently a full-fledged member of the division team and should continue in that role. Its contributions to the combat power of the division are considerable. The battalion trains with the division across the full range of contingencies and, through the professional relationships and comraderie that develops, contributes toward creation of a climate that inspires commanders to display initiative.

Depth, important to all Army operations, refers to time, distance and resources. If enemy forces are echeloned in depth and have numerical superiority, U.S. forces must "see deep" into the enemy rear area and strike deep to destroy, delay or disrupt the enemy. The deep battle normally takes place outside of the division area of influence and certainly beyond the range of its sensors. The corps commander takes control of the operation. It remains his responsibility "to find and disrupt the advance of second-echelon divisions of first-echelon armies before they become a part of the first-echelon problem."¹⁰ To do so, the corps must have intelligence assets focused on enemy movements and dispositions to determine the critical time to initiate the operation. Alternative 2 would not provide the corps commander any additional assets that could be utilized to improve his intelligence picture of the deep battle area. The objectives of the deep attack are oriented on the enemy's forces but, with limited assets normally committed, the corps commander must avoid decisive engagement and battles of attrition. Any gaps in intelligence must be filled by reliance on EAC and national systems. The deep attack force must be provided as complete an intelligence preparation of the battlefield (IPB) as

REPRODUCED AT GOVERNMENT EXPENSE

possible. The close-in fight is linked to the deep battle and success in Air Land Battle requires that both be won. Alternative 2 would deny division control of organic IEW assets and limit its ability to effectively fight the close-in battle. Alternative 1 retains organic IEW support at each tactical echelon assigned a major role in fighting Air Land Battle.

Agility can provide a force considerable advantage. It implies an ability to avoid enemy strengths and take advantage of his vulnerabilities. It requires flexible organizations and leaders who can "out-think" the enemy. Commanders must have a real-time knowledge of the events taking place on the battlefield so that the opportunities presented by unforeseen circumstances will not be missed. This must be a continual process so that, every time the enemy begins a new operation, we are in a position to upset his plans. This action will lead to ineffective and uncoordinated enemy responses. Agility on the battlefield requires detailed knowledge of the enemy acquired only through systematic and sometimes long-term analysis of enemy capabilities and intentions. Alternative 1 provides both corps and division an organic capability to track the events on a dynamic battlefield. Alternative 2 establishes that capability at corps, providing it the resources to conduct expanded coverage of the activities in the battle area. The element attached to the division would probably be of a size and mix sufficient only to meet immediate intelligence requirements. Transmission of information from corps to subordinate commanders would not approach real-time. The consequences of delays might prove unacceptable. "Companies and battalions generally need combat information about activity in their

area of influence in minutes; brigade, perhaps within 15-30 minutes; division, within an hour."¹¹ The agility of a committed force need not be restricted by the assignment of IEW assets since tactical jamming and intelligence systems have the mobility to keep up with combat units. The agility gained by assignment of a CEWI battalion to the division is a capability that would be realized in any theater of operations.

Synchronized, violent execution is the essence of decisive combat. Unity of effort throughout the force is required for attainment of maximum combat power. Flexible, timely and survivable C³ systems are required to control the battle. So too, enemy C³ systems should be a top priority target for friendly IEW assets. The concept of operations at division and corps should address the destruction or disruption of enemy C³. The achievement of that objective is critical to commanders at all levels. The integrated battlefield demands a close link between all actors and activities. Coordinated IEW operations, particularly in conjunction with maneuver and fire support, allow for economy of force and achievement of tactical advantage. The goal of "disrupting or neutralizing 50% of the enemy's critical C² systems"¹² would be more difficult under Alternative 2. Available short-range jammers would only be effective if employed in the area of the FLOT, preferably under division control. The requirement to coordinate operations across the corps front is facilitated by knowledge of enemy dispositions, strengths and intentions. Control and direction of the division battle is made that much more difficult when the element providing IEW support

REPRODUCED AT GOVERNMENT EXPENSE

is not fully integrated into the administrative, logistics and operational routines of the division. A division commander in combat cannot afford to compete for available IEW assets. Attachment still leaves ties to a control element at corps which could diminish the quality of support provided. Alternative 1 provides the full range of IEW capability and makes it immediately available to the commander.

Conclusion. On balance, the advantages of Alternative 1 far outweigh Alternative 2. Decentralized operations appear to be the better approach given the violence, intensity and confusion that will characterize the modern battlefield. Divisional CEWI units can continue to provide significant input to the corps intelligence data base but will retain for the division commander the capability to conduct independent operations when called for by the battle situation. The current CEWI organization has its flaws, centered mostly on equipment and capability limitations, but the structure and concept are sound. Advanced technologies such as remotely piloted vehicles (RPV), over the horizon radar, airborne jammers, real-time data links, and automated processing systems will close many of the gaps that presently exist. These programs should be accelerated. Expanded training and coordination with EAC and the USAF will build the teamwork and foster the supportive relationships that will be demanded by Air Land Battle if employed over a wide range of potential contingencies.

REPRODUCED AT GOVERNMENT EXPENSE

CHAPTER IV

IEW EQUIPMENT AND CAPABILITIES CONSIDERATIONS

The Problem. The AirLand Battle concept outlined in Field Manual 100-5, Operations, and U.S. Army Training and Doctrine Command Pamphlet 525-5, The AirLand Battle and Corps 86, extends the battlefield for commanders with an emphasis on the use of intelligence, target acquisition and integrated interdiction assets not seen previously in Army doctrine. This new doctrine was first presented by retired General Donn A. Starry -- then commander of the U.S. Army Training and Doctrine Command (TRADOC) -- with his article, "Extending the Battlefield" in the March 1981 issue of Military Review. To quote Starry directly from that article:

"The battlefield and the battle are extended in three ways. First, the battlefield is extended in depth, with engagement of enemy units not yet in contact to disrupt the enemy timetable, complicate command and control and frustrate his plans, thus weakening his grasp on the initiative. Second, the battle is extended forward in time to the point that current actions such as attack of follow-on echelons, logistical preparation and maneuver plans are interrelated to maximize the likelihood of winning the close-in battle as time goes on. And lastly, the range of assets figuring in the battle is extended toward more emphasis on higher level Army and sister service acquisition means and attack resources."¹³

Each level of command incurs a dual responsibility. Each must attack one of the enemy's assault echelons and must see, or determine the intentions of, a follow-on echelon. This imposes a considerable time and space burden on tactical commanders. Division commanders are expected to take responsibility for areas of influence and interest that extend out to 150 kilometers and 72 hours enemy reaction time (FIGURE 3). For the corps commander, the requirement is 300 kilometers and 96 hours. The linchpin to that situation, as

REPRODUCED AT GOVERNMENT EXPENSE

FIGURE 3

CORPS AREAS OF INFLUENCE AND INTEREST

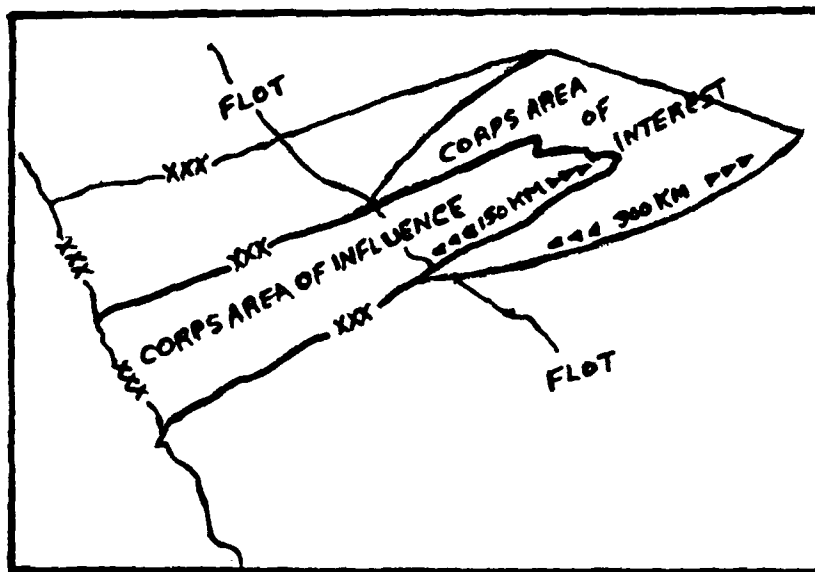
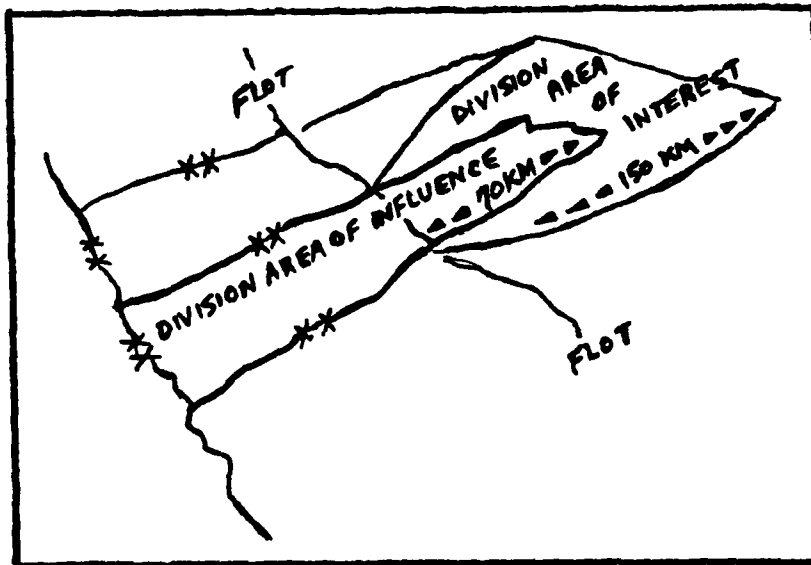

FIGURE 4

DIVISION AREAS OF INFLUENCE AND INTEREST



Source: Military Intelligence, July-September 1981.

REPRODUCED AT GOVERNMENT EXPENSE

well as to the entire operational concept, is accurate and timely intelligence on enemy forces, the terrain and the weather. Unfortunately, in the intervening budget processes and congressional sessions between General Starry's 1981 article and the time of this paper, several of the key tactical IEW systems -- including the All-Source Analysis System (ASAS), the Standoff Target Acquisition System (SOTAS) and the Tactical Fire Direction Program -- either have been eliminated or emasculated.¹⁴ New systems are being designed and programmed, such as the Joint Surveillance and Target Attack Radar System (JSTARS), but there is no assurance that these programs will not meet the same fate before they get to the field. Many gaps in the intelligence capabilities of our forces still exist. Commanders at each tactical echelon must place too much reliance on higher headquarters and sister services to satisfy their intelligence requirements. The initiative, agility, depth and synchronization that are the strengths of Air Land Battle, and indeed the keys to its success, will not be achievable unless these gaps are plugged.

The Division. The emphasis at division is on fire and maneuver. The attack of the enemy second echelon must be timed so that they are stopped long enough for the brigades to defeat the enemy first-echelon regiments in close combat. IEW support at division must, therefore, emphasize rapid collection and reporting of targeting information to the fire support element (FSE), target development using all-source analysis, and jamming of enemy communications. The key is to permit "effective, continuous interdiction"¹⁵ by providing Army divisions the capability to see second-echelon assaulting regiments or defending enemy battalions. A division

REPRODUCED AT GOVERNMENT EXPENSE

FIGURE 5

IEW CAPABILITY: MI BN (CEWI) (DIV)

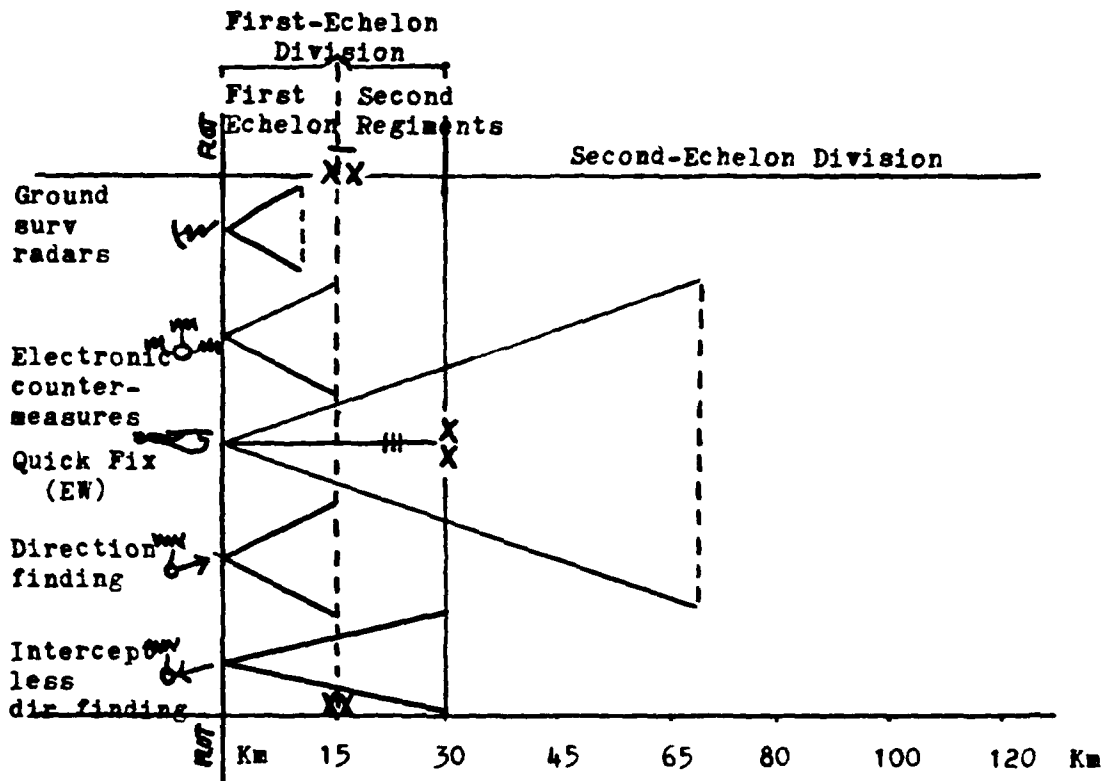

Source: "Combat Intelligence for the Deep Attack," Military Review, April 1983, p. 45.

commander is assigned areas of influence and interest that extend out to 150 kilometers. The division's ability to see beyond the forward line of own troops (FLOT) rests with organic intelligence collectors, primarily the cavalry squadron, patrols and the CEWI battalion. On the extended battlefield, the bulk of the division's IEW effort is assigned to the CEWI battalion because the cavalry squadron and the patrols are more involved with the close-in battle.

REPRODUCED AT GOVERNMENT EXPENSE

Herein lies the problem. Army doctrine requires that "echelons of command responsible for operations in areas of influence are also responsible for finding, targeting, following and reporting on enemy forces there."¹⁶ But, this is a relatively new requirement. Prior to the current emphasis on deep attack, there was little interest in a division-level, deep coverage, electronic combat capability. Brigade and division commanders were oriented on an enemy that would engage them in the close-in battle. Today, the equipment they have to work with reflects that orientation. The majority of equipment assigned to the division does not have a capability beyond 15 kilometers (FIGURE 5). Coverage beyond that range must be provided by corps, EAC or the Air Force. While the integrated battlefield aspect of Air Land Battle is an important element of the concept, the initiative and boldness that is expected of tactical commanders will be somewhat frustrated if they must constantly rely on outside sources for intelligence and targeting information. An additional problem is that, even when outside assets acquire deep targets in the division's area of influence, adequate corps-to-division secure communications must be available to provide the timely, accurate information necessary for tactical decisionmaking at division level. With currently fielded equipment, it is doubtful that communications will consistently support timely dissemination to the division.

The new IEW equipments programed for Division 86 units include a ground-based jammer, a series of expendable jammers and a heliborne intercept/ direction-finding/jamming system. The heliborne system, Quick Fix, is especially significant because it is the di-

vision's only authorized electronic combat asset with a genuine capability to see and electronically interdict to a reasonable depth on the extended battlefield. The Standoff Target Acquisition System (SOTAS) was another system earmarked for the division which had the range to locate second-echelon targets and to look deep into the extended battlefield but it appears to be a terminal victim of cost overruns. And Quick Fix is years away from its introduction into the inventory in significant.

If the division commander is to remain tasked to fight the Air Land Battle and to influence the action out to 70 kilometers, he must be provided the means to do so -- air and ground IEW assets which will complement each other and provide in-depth coverage of the commander's area of influence, and reliable, timely and survivable communications which will link the division with the corps and other sources of intelligence and targeting information.

The Corps. The corps is the principal force in a theater of operations and the corps commander is the key U.S. Army player in fighting the Air Land Battle. The corps areas of influence and interest extend out to 300 kilometers. The corps interfaces with EAC, national surveillance systems, and the U.S. Air Force to obtain intelligence on enemy units and activities in their respective areas of interest. This follows the concept that each echelon must provide surveillance coverage for the next lower echelon's area of interest. The corps will observe and provide intelligence of all types on the division's area of interest (out to 150 kilometers) which the division cannot adequately. FIGURE 6 provides a graphic display of the increased capabilities of the IEW systems assigned

to the MI Battalion (CEWI) (Corps).

FIGURE 6

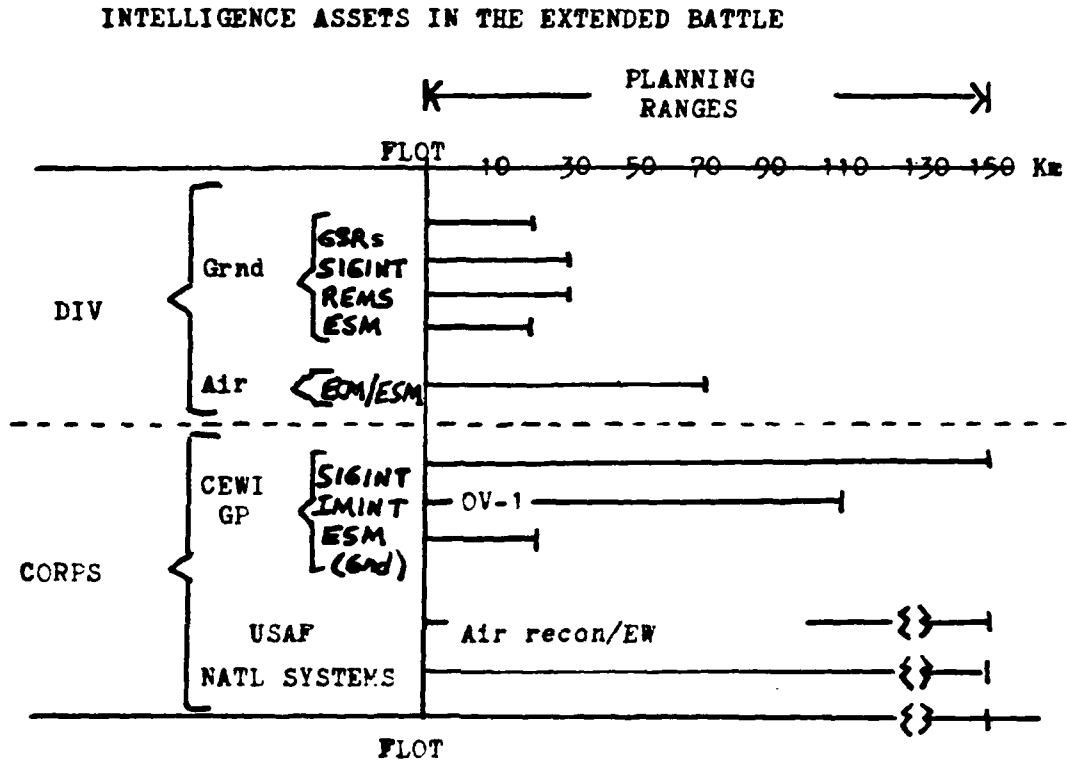

FLOT - Forward line of own troops
 GSRs - Ground surveillance radars
 SIGINT - Signals intelligence
 REMS - Remotely employed sensors
 ESM - Electronic warfare spt measure
 ECM - Electronic countermeasures
 IMINT - Imagery intelligence

Organic deep target coverage is provided by the fixed-wing aviation assets assigned to the CEWI Group. Communications intelligence (COMINT) is provided by the Guardrail system -- mounted on RU21H aircraft -- assigned to the Aerial Exploitation Battalion (AEB). Imagery intelligence (IMINT) is provided by the OV-10 Mohawk system in the Aerial Surveillance Company of the AEB. These aircraft have side-looking airborne radar (SLAR), infrared (IR), and photographic capabilities. Both of these systems have near-real-time data links which are located with the tactical commanders. A third system,

REPRODUCED AT GOVERNMENT EXPENSE

Quicklook II (mounted on Mohawk aircraft), provides electronic intelligence (ELINT) support to the corps area. None of the aviation systems provides coverage beyond approximately 150 kilometers of the FLOT. As with the division commander, the corps commander must rely on outside agencies for coverage of his area of interest. This is an unacceptable situation when the necessary communication links or the appropriate collection management techniques are not available. This is the situation currently but emerging systems should rectify the situation. New systems for aerial surveillance stress the need for near real-time transmission, for digital data, to a ground station for exploitation. The Interim Elint Tactical Processor (ITEP) is the ground processor for information received in real-time from USAF aircraft. The development of the ITEP, the TACIES, and the synthetic aperture radar (SAR) processing systems will provide the Corps 86 MI Group with Air Land Battle capabilities far greater than those of the current MI Group. Close and constant coordination with the USAF and national systems is required for collection management and rapid exploitation of these assets. When fielded, these systems should complement current systems to provide the corps commander complete, periodic, near real-time surveillance over his entire area of interest.

There are some other areas that must be resolved. First, is the processing of massive amounts of data and timely dissemination to tactical commanders. The All-Source Analysis System (ASAS) is the key. It will provide real-time information processing, analysis and reporting and a sophisticated communications link between corps and division. Its funding difficulties must be rectified. Second, the

integrated battlefield will not not work without Army/USAF cooperation. Duplication of effort must be avoided through the joint development of automated systems for collecting, processing and communicating. Future development of joint/combined systems with interoperability/commonality of sensors and processors, along with carefully developed standard operating procedures will be the key to success in the Air Land Battle. Third, action must be taken to improve the survivability of the IEW aviation assets. They will be the most responsive deep coverage source. Improved survivability equipment, modified flight profiles and expanded crew training are areas that can be targeted for investigation. Fourth, maximum use should be made of state-of-the-art aerial vehicles as potential platforms for mounting IEW systems. Remotely piloted vehicles (RPVs) and ultra-light vehicles are two possibilities. They would greatly enhance the commander's flexibility and significantly expand the surveillance of the battlefield.

REPRODUCED AT GOVERNMENT EXPENSE

CHAPTER V

CONCLUSIONS

The U.S. Army has made a commitment to the doctrine of Air Land Battle. The key to success on the battlefield will be the ability to see deep and begin early to disrupt, delay and destroy follow-on/reinforcing echelons. The deep attack is no longer a luxury, "it is an absolute necessity to winning."¹⁷ The bulk of the intelligence/combat information required for tactical decisionmaking will be provided by the CEWI units assigned at corps and division. On balance, it appears that the assignment of IEW assets at each tactical echelon rather than consolidation at the corps is the best way to go. Decentralized operations offer the best chance for success given the violence, intensity and confusion that will characterize the modern battlefield. The CEWI organization, as currently structured, makes a significant contribution to the combat power of each tactical echelon. Commanders, by command and control of their own organic IEW assets, are more readily able to exercise the initiative, agility, depth and synchronization that will be essential to win. There are, however, serious equipment limitations that result in gaps in the intelligence capabilities of our forces. Commanders at each echelon must place too much reliance on higher headquarters and sister services to satisfy their intelligence requirements. Organic assets do not provide adequate coverage of commanders' areas of influence and, certainly not, the areas of interest. Emerging systems under the Army 86 program will resolve many of the deficiencies but other areas remain to be resolved, including: processing of massive amounts of data, improved Army/USAF cooperation, enhanced surviva-

REPRODUCED AT GOVERNMENT EXPENSE

bility of IEW aviation assets and the development of new aerial platforms.

REPRODUCED AT GOVERNMENT EXPENSE

NOTES

Chapter I

1. General E.C. Meyer, White Paper 1980: A Framework for Molding the Army of the 1980s into a Disciplined, Well-Trained Fighting Force, February 25, 1980, p. 1.
2. Ibid., p. 3.
3. The Honorable John O. Marsh and General E.C. Meyer, The Posture of the Army and Department of the Army Budget Estimates for Fiscal Year 1984, p. 8.
4. The Honorable Caspar W. Weinberger, Annual Report to the Congress, 1984, p. 31.
5. Eric C. Ludvigsen, "Elite Light Divisions Among Major Focuses in '85 Army Budget," Army, April 1984, p. 35.
6. Paul Dickson, The Electronic Battlefield (Bloomington: Indiana University Press, 1976), p. 71.
7. Combat Electronic Warfare Intelligence Group, Corps: Operational and Organizational Concepts, p. II.

Chapter III

8. U.S. Army Training and Doctrine Command (TRADOC) Pamphlet 525-5, The AirLand Battle and Corps 86, Department of the Army, Washington, D.C., March 1981, p. 40.
9. Major Charles W. Thomas, "Combat Intelligence for the Deep Attack," Military Review, April 1983, p. 44.
10. Colonel William G. Hanne, "Doctrine not Dogma," Military Review, June 1983, p. 18.
11. TRADOC Pamphlet 525-5, p. 42.
12. Ibid., p. 43.

Chapter IV

13. Hanne, p. 13.
14. Ibid., p. 17.
15. General Donn A. Starry, "Extending the Battlefield," Military Review, March 1981, p. 32.
16. TRADOC Pamphlet 525-5, p. 42.

Chapter V

17. Ibid., p. 3.

BIBLIOGRAPHY

- Burton, Ralph W. "Military Intelligence Support to Corps and the Air/Land Battle," Military Intelligence, July-September 1981, pp. 6-8.
- Burton, Ralph W. "Military Intelligence Support to Division and the Air/Land Battle," Military Intelligence, July-September 1981, pp. 9-12.
- Combat Electronic Warfare Intelligence Group, Corps: Operational and Organizational Concepts, p. II.
- Deal, C. Lanier. "The Key to the Deep Battle," Military Review, March 1982, pp. 51-54.
- Dickson, Paul. The Electronic Battlefield. Bloomington: Macmillan, 1976.
- Doerfel, John S. "The Operational Art of the AirLand Battle," Military Review, May 1982, p. 3-10.
- Ludvigsen, Eric C. "Elite Light Divisions Among Major Focuses In '85 Army Budget," Army, April 1984, pp. 34-48.
- Marsh, John O. and Meyer, E.C. The Posture of the Army and Department of the Army Budget Estimates for Fiscal Year 1984.
- Meyer, E.C. White Paper 1980: A Framework for Molding the Army of the 1980s into a Disciplined, Well-Trained Fighting Force, February 25, 1980.
- Starry, Donn A. "Extending the Battlefield," Military Review, March 1981, pp. 29-34.
- Thomas, Charles W. "Combat Intelligence for the Deep Attack," Military Review, April 1983, pp. 42-51.
- Weinberger, Caspar W. Annual Report to the Congress, 1984.
- Headquarters, Department of the Army. Field Manual 100-5, Operations, 20 August 1982.
- Headquarters, U.S. Army Training and Doctrine Command. Pamphlet 525-5, The AirLand Battle and Corps 86, 25 March 1981.