

2

NAVAL POSTGRADUATE SCHOOL Monterey, California

AD-A144 441



DTIC
ELECTE
AUG 17 1984
S
B

THESIS

DTIC FILE COPY

AN ANALYSIS OF COHERENT DIGITAL
RECEIVERS IN A JAMMING ENVIRONMENT
by
Faris Thomas Farwell, Jr.
June 1984
Thesis Advisor: Daniel Bukofzer

Approved for public release, distribution unlimited

84 08 16 037

UNCLASSIFIED

SECURITY CLASSIFICATION OF THIS PAGE (When Data Entered)

REPORT DOCUMENTATION PAGE		READ INSTRUCTIONS BEFORE COMPLETING FORM	
1. REPORT NUMBER	2. GOVT ACCESSION NO. <i>A144444</i>	RECIPIENT'S CATALOG NUMBER	
4. TITLE (and Subtitle) An Analysis of Coherent Digital Receivers in a Jamming Environment		5. TYPE OF REPORT & PERIOD COVERED Master's Thesis June 1984	
		6. PERFORMING ORG. REPORT NUMBER	
7. AUTHOR(s) Faris Thomas Farwell, Jr.		8. CONTRACT OR GRANT NUMBER(s)	
9. PERFORMING ORGANIZATION NAME AND ADDRESS Naval Postgraduate School Monterey, California 93943		10. PROGRAM ELEMENT, PROJECT, TASK AREA & WORK UNIT NUMBERS	
11. CONTROLLING OFFICE NAME AND ADDRESS Naval Postgraduate School Monterey, California 93943		12. REPORT DATE June 1984	
		13. NUMBER OF PAGES 94	
14. MONITORING AGENCY NAME & ADDRESS (if different from Controlling Office)		15. SECURITY CLASS. (of this report) Unclassified	
		15a. DECLASSIFICATION/DOWNGRADING SCHEDULE	
16. DISTRIBUTION STATEMENT (of this Report) Approved for public release, distribution unlimited.			
17. DISTRIBUTION STATEMENT (of the abstract entered in Block 20, if different from Report)			
18. SUPPLEMENTARY NOTES			
19. KEY WORDS (Continue on reverse side if necessary and identify by block number) Jamming effects on Coherent Receivers			
20. ABSTRACT (Continue on reverse side if necessary and identify by block number) → The effect of various jammer waveforms on known optimum coherent digital receivers is analyzed and evaluated in terms of receiver performance. The optimum jammer waveform for the specified receiver is derived and several jamming strategies are studied and compared to the optimum case. These jammer waveforms strategies include deterministic models of tonal, weighted signals, frequency modulated, and additive white noise jammers. CON'T			

UNCLASSIFIED

SECURITY CLASSIFICATION OF THIS PAGE (When Data Entered)

An M-ARY digital coherent receiver using orthogonal modulation (FSK), is subjected to various jammer waveforms and the receiver performance analyzed. Graphical results based on numerical analyses are presented to show the effects of jammer waveforms on receiver performance.

X

Accession For	
NTIS GFA&I	<input checked="" type="checkbox"/>
DTIC TAB	<input type="checkbox"/>
Unannounced	<input type="checkbox"/>
Justification	
By	
Distribution/	
Availability Codes	
Dist	Avail and/or Special
A-1	

DTIC
COPY
INSPECTED
2

S N 0102- LF-014-6601

1a

UNCLASSIFIED

SECURITY CLASSIFICATION OF THIS PAGE(When Data Entered)

Approved for public release; distribution unlimited.

An Analysis
of
Coherent Digital Receivers in a Jamming Environment

by

Faris T. Farwell, Jr.
Lieutenant, United States Navy
B.S., U.S. Naval Academy, 1978

Submitted in partial fulfillment of the
requirements for the degree of

MASTER OF SCIENCE IN ELECTRICAL ENGINEERING

from the

NAVAL POSTGRADUATE SCHOOL
June 1984

Author:

Faris T. Farwell Jr.

Approved by:

David Barber

Thesis Advisor

S. J. Jansen

Second Reader

Robert Steinberg

Chairman, Department of Electrical and Computer Engineering

John Dyer

Dean of Science and Engineering

ABSTRACT

The effect of various jammer waveforms on known optimum coherent digital receivers is analyzed and evaluated in terms of receiver performance. The optimum jammer waveform for the specified receiver is derived and several jamming strategies are studied and compared to the optimum case. These jammer waveform strategies include deterministic models of tonal, weighted signals, frequency modulated, and additive white noise jammers. An M-ARY digital coherent receiver using orthogonal modulation (PSK), is subjected to various jammer waveforms and the receiver performance analyzed. Graphical results based on numerical analyses are presented to show the effects of jammer waveforms on receiver performance.

TABLE OF CONTENTS

I.	INTRODUCTION	9
II.	COHERENT RECEIVER ANALYSIS	11
	A. COHERENT CORRELATOR RECEIVERS	11
	B. JAMMER OPTIMIZATION	18
	C. DETERMINISTIC JAMMING FOR PSK, FSK, AND ASK MODULATION	24
	D. WEIGHTED SIGNAL JAMMERS	29
	E. FREQUENCY MODULATED JAMMING	36
	F. NEAR OPTIMUM JAMMERS	44
	G. ADDITIVE NOISE JAMMERS	47
	H. VARIABLE THRESHOLDING EFFECTS	50
III.	EFFECTS OF DETERMINISTIC JAMMERS ON M-ARY ORTHOGONAL RECEIVERS	52
	A. M-ARY ORTHOGONAL RECEIVER MODEL	52
	B. RECEIVER PERFORMANCE	54
	C. JAMMER MODEL	59
IV.	DESCRIPTION OF GRAPHICAL RESULTS	65
	A. DISCUSSION ON GRAPHICAL RESULTS	65
	B. OPTIMUM JAMMERS	65
	C. WEIGHTED SIGNAL JAMMERS	66
	D. FREQUENCY MODULATED JAMMERS	67
	E. NEAR OPTIMUM JAMMERS	68
	F. M-ARY RECEIVERS GRAPHICAL RESULTS	68
V.	CONCLUSION	70
	LIST OF REFERENCES	92

BIBLIOGRAPHY 93
INITIAL DISTRIBUTION LIST 94

LIST OF FIGURES

5.1	Coherent Correlator Receiver	72
5.2	Single Correlator Coherent Receiver	73
5.3	Coherent Correlator Receiver in a Jamming Environment	74
5.4	Single Correlator Receiver in a Jamming Environment	75
5.5	Optimum Jammer for PSK Modulated Signal	76
5.6	Optimum Jammer for FSK Modulated Signal	77
5.7	Optimum Jammer for ASK Modulated Signal	78
5.8	Weighted Signals Jammer for PSK Modulated Signal	79
5.9	One Channel Jam Weighted Signals for FSK Modulation	80
5.10	Partial Channel Jam Weighted Signals for FSK Modulation	81
5.11	Frequency Modulated Jammer	82
5.12	Frequency Modulated Jammer for PSK Modulated Signal	83
5.13	Frequency Modulated Jammer for PSK Modulated Signal	84
5.14	Frequency Modulated Jammer for FSK Modulated Signal	85
5.15	Frequency Modulated Jammer for FSK Modulated Signal	86
5.16	Near Optimum Jammer	87
5.17	M-ary Coherent Correlator Receiver	88
5.18	M-ary FSK with Single Channel Jam (M=2)	89

5.19	M-ary FSK with Single Channel Jam (M=10) 90
5.20	M-ary FSK with Single Channel Jam (M=100) 91

ACKNOWLEDGEMENT

I wish to express my appreciation to my thesis advisor, Prof. Daniel Bukofzer, for his efforts and patience in assisting me throughout my research. I also would like to express my gratitude to my wife [REDACTED] and my young son, [REDACTED], for their support.

I. INTRODUCTION

The concepts of statistical decision theory applied to digital communication theory for the purpose of designing optimum receivers is widely known. The nature of many communication channels is characterized by their interference to reception through additive noise. Receivers have been designed to optimize the output receiver signal to noise ratio in the presence of additive white Gaussian noise interference. However, noise is not the sole source of receiver interference. Jamming, intentional or not, can be severely detrimental to receiver performance.

This thesis endeavors to investigate the effect of jamming on digital coherent communication receivers. Mathematical models of signals, interference, and jamming are utilized to demonstrate performance (i.e. - receiver probability of error) of receivers designed to operate in a 'noise only' interference environment, in the presence of both noise and jamming. From the mathematical models, optimum jamming techniques are derived, and various sub-optimum jamming strategies are analyzed.

The results are divided into three sections. In section number one coherent receivers are investigated under various jamming conditions. The optimum jamming waveform based on power constraints is derived and analyzed. Performance of coherent FSK and PSK receivers are analyzed in the presence of both optimum and sub-optimum jamming waveforms. These jamming waveforms include, weighted jammers, frequency modulated jammers, and two-level pulsed jammers. Section number two discusses higher level digital coherent receivers in which M-ARY FSK receivers are analyzed in the presence of jamming. Mathematical models are introduced and results

compared to the optimum case for binary FSK. Finally, in section number three graphical presentations corresponding to the numerical analyses that have been performed are interpreted in order to demonstrate the mathematical results.

II. COHERENT RECEIVER ANALYSIS

A. COHERENT CORRELATOR RECEIVERS

The application of statistical decision theory to the problem of detecting signals in the presence of noise can be used to design optimum receivers. However it is important to note that the receivers are optimum under a given set of assumptions. The receiver which is optimum (in the sense of producing minimum probability of error, P_e) for the discrimination of two different signals received in additive white Gaussian noise interference is well documented [Ref. 1], and the receiver structure is as given in Figure 5.1. This optimum receiver is a correlator receiver, due to the cross correlation process it performs between the input $r(t)$, and the signal $s_0(t)$ and $s_1(t)$. This optimum correlator receiver can be shown to be equivalent to the single correlator receiver of Figure 5.2. The receivers of Figure 5.1 and Figure 5.2 have been shown to be optimum (i.e. -minimum probability of error) when the received signal is either

$$\begin{aligned} R(T) &= S_0(T) + N(T) & 0 \leq t \leq T \\ \text{or,} \\ R(T) &= S_1(T) + N(T) & 0 \leq t \leq T \end{aligned}$$

where $s_0(t)$ and $s_1(t)$ are known deterministic signals and $n(t)$ is a sample function of a white Gaussian process.

The objective of this chapter is to analyze the performance of this known optimum receiver under different operating rules; i.e. - the signal received is interfered by the presence of a jammer waveform as well as additive white Gaussian noise. That is

$$\begin{aligned} r(t) &= s_0(t) + n(t) + n_j(t) & 0 \leq t \leq T \\ \text{or,} \\ r(t) &= s_1(t) + n(t) + n_j(t) & 0 \leq t \leq T \end{aligned}$$

where $n_j(t)$ is a jammer waveform modeled as deterministic, yet unknown to the receiver.

The correlator receiver structure depicted in Figure 5.3 which can be shown to be equivalent to the optimum single correlator receiver of Figure 5.4 is now analyzed under the stated assumptions. We define

$$s_d(t) = s_{\perp}(t) - s_o(t)$$

$$c = \text{BIAS} = 1/2 \int_0^T (s_o^2(t) - s_{\perp}^2(t)) dt$$

$$\chi = N_o / 2 \ln(\lambda_o) \qquad \lambda_o = P(s_o) / P(s_{\perp})$$

where

$$P(s_o) \text{ and } P(s_{\perp}) = \text{LIKELIHOOD FUNCTIONS}$$

The coherent digital communication receiver of Figure 5.4 can be analyzed in terms of the resulting P_e when the jammer waveform $n_j(t)$ is present in addition to the noise and $s_o(t)$ and $s_{\perp}(t)$. The received signal appearing at the front end of the receiver is mathematically described by

$$r(t) = s_i(t) + n(t) + n_j(t) \quad 0 \leq t \leq T \quad i = (0, \perp)$$

where $s_o(t)$ and $s_{\perp}(t)$ are the two signals used to transmit the binary information, $n(t)$ is a sample function of a white Gaussian noise process having a power spectral density level of $N_o / 2$ Watts/Hz, and $n_j(t)$ is the deterministic jammer waveform present during the signaling interval $(0, T)$.

The coherent receiver of figure 5.4 will be analyzed in so far as the effect of $n_j(t)$ on the receiver probability of error is concerned. The correlation process generates

$$\int_0^T r(t) s_d(t) dt = \int_0^T (s_i(t) + n(t) + n_j(t)) s_d(t) dt \quad (2.1)$$

Inner product notation will be used, that is

$$(X, Y) = \int_0^T x(t) y(t) dt \quad (2.2)$$

and the norm notation $\|*\|$ follows from

$$\|X\|^2 = (X, X) \quad (2.3)$$

In order to determine receiver performance (i.e.- probability of error) the decision rule used by the receiver must be analyzed. This decision rule is given by

$$\int_0^T r(t) s_1(t) dt - \int_0^T r(t) s_0(t) dt + \frac{1}{2} \int_0^T [s_0^2(t) - s_1^2(t)] dt \geq \gamma \quad (2.4)$$

where for convenience we define

$$G = (r, s_d) + \frac{1}{2} [\|s_0\|^2 - \|s_1\|^2] \quad (2.5)$$

In order to compute receiver probability of error it is necessary to determine the probability density function of G conditioned on the hypotheses H_1 and H_0 ; that is on whether $s_1(t)$ or $s_0(t)$ was transmitted. Thus,

$$\begin{aligned} H_1: r(t) &= s_1(t) + n(t) + n_j(t) \\ H_0: r(t) &= s_0(t) + n(t) + n_j(t) \end{aligned} \quad 0 \leq t \leq T.$$

Denoting these density functions $P_1(G)$ and $P_0(G)$, we can express the probability of error as

$$P_e = P(D_1/H_0)P(H_0) + P(D_0/H_1)P(H_1) \quad (2.6)$$

Where $P(D_1/H_0)$ equals the probability of deciding that $s_1(t)$ was transmitted given that $s_0(t)$ was transmitted, and $P(D_0/H_1)$ equals the probability of deciding that $s_0(t)$ was transmitted given that $s_1(t)$ was transmitted. For the hypotheses of H_0 and H_1 Equation 2.6 becomes

$$P_e = \frac{1}{2} \int_{\gamma}^{\infty} P_0(G) dG + \frac{1}{2} \int_{-\infty}^{\gamma} P_1(G) dG \quad (2.7)$$

Since G is a conditional Gaussian random variable, in order to obtain its conditional probability density function its mean and variance must be computed.

The mean is given by

$$\begin{aligned} E(G/s_i(t) \text{ transmitted}) &= (s_i, s_d) + E\{(n, s_d)\} + (1_j, s_d) \\ &+ 1/2 (\|s_0\|^2 - \|s_1\|^2) \quad i=0,1 \end{aligned}$$

Due to the assumption of zero mean noise, $E((n, s_d)) = 0$. Thus the mean value becomes

$$E\{G/s_i\} = (s_i, s_d) + (N_j, s_d) + \frac{1}{2} [\|s_0\|^2 - \|s_1\|^2] \quad i = 0, 1. \quad (2.8)$$

It can easily be shown that the conditional variance of G will be due to the noise process only. That is

$$\text{VAR}_i(G) = E((G - E_i(G))^2) \quad i = 0, 1$$

where $\text{Var}_i(G)$ is the variance of G conditional on $s_i(t)$ being transmitted. It can easily be shown that

$$\text{VAR}_0\{G\} = \text{VAR}_1\{G\} = \frac{1}{2} N_0 \int_0^T [s_1(t) - s_0(t)]^2 dt. \quad (2.9)$$

Equation 2.9 can be written as

$$\text{VAR}\{G/s_i(t) \text{ TRANSMITTED}\} = \frac{N_0}{2} \|s_d\|^2, \quad i = 0, 1. \quad (2.10)$$

With the mean and variance known, the probability of error can now be written using the following general notation

$$f_G(g) = \frac{1}{\sqrt{2\pi \sum \text{VAR}(g)}} \cdot \exp\left[-\frac{(g - E\{g\})^2}{2 \cdot \sum \text{VAR}(g)}\right] \quad (2.11)$$

Due to conditioning, the probability density functions become

$$f_G(g/s_i \text{ TRANSMITTED}) = \frac{1}{\sqrt{2\pi \frac{N_0}{2} \|s_d\|^2}} \cdot \exp\left[\frac{-[g - (s_i, s_d) - (n_j, s_d) - \frac{1}{2}[\|s_0\|^2 - \|s_d\|^2]]^2}{2 \cdot [\frac{N_0}{2} \cdot \|s_d\|^2]}\right] \quad i = 0, 1. \quad (2.12)$$

From the probability of error expression (Equation 2.7), we have

$$P_e = (1-p) \int_{\gamma}^{\infty} \frac{1}{\sqrt{\pi N_0 \|s_d\|^2}} \exp\left\{-\frac{[g + \frac{1}{2}\|s_d\|^2 - (n_j, s_d)]^2}{N_0 \|s_d\|^2}\right\} dg + (p) \int_{-\infty}^{\gamma} \frac{1}{\sqrt{\pi N_0 \|s_d\|^2}} \exp\left\{-\frac{[g - \frac{1}{2}\|s_d\|^2 - (n_j, s_d)]^2}{N_0 \|s_d\|^2}\right\} dg, \quad (2.13)$$

where

p = probability that $s_1(t)$ transmitted

γ = decision rule threshold setting.

Using the following definition of the error function

$$\text{ERF}(V) \doteq \int_{-\infty}^V \frac{1}{\sqrt{2\pi}} e^{-x^2/2} dx \quad (2.14)$$

and the complimentary error function

$$\text{ERFC}(V) \doteq \int_V^{\infty} \frac{1}{\sqrt{2\pi}} e^{-x^2/2} dx = 1 - \text{ERF}(V), \quad (2.15)$$

Equation 2.13 can be written in a more compact form. With a change of variables Equation 2.13 becomes

$$P_e = (1-p) \text{ERFC} \left[\sqrt{\frac{2}{N_0 \|S_d\|^2}} \cdot \left[\gamma + \frac{1}{2} \|S_d\|^2 - (N_j, S_d) \right] \right] \\ + (p) \text{ERF} \left[\sqrt{\frac{2}{N_0 \|S_d\|^2}} \cdot \left[\gamma - \frac{1}{2} \|S_d\|^2 - (N_j, S_d) \right] \right]. \quad (2.16)$$

If equiprobable signals are transmitted, $p=1/2$, and the threshold setting becomes

$$\gamma = \frac{N_0}{2} \ln \frac{(1-p)}{p} = 0, \quad (2.17)$$

which corresponds to a 'zero threshold' receiver. It should be noted that this may not necessarily be the most desirable threshold setting, and in fact values other than zero may enhance receiver performance whenever jamming is present. With the above stated conditions, the probability of error equation takes on the form [Ref. 2]

$$P_e = \frac{1}{2} \text{ERFC} \left[s_q \left[N_d - d \right] \right] + \frac{1}{2} \text{ERF} \left[s_q \left[N_d + d \right] \right] , \quad (2.18)$$

where

$$s_q \doteq \sqrt{\frac{2}{N_0 \|s_d\|^2}} , \quad N_d \doteq \frac{\|s_d\|^2}{2} , \quad d \doteq (N_j, s_d) .$$

B. JAMMER OPTIMIZATION

Utilizing Equation 2.18 , the effect of a jammer waveform can now be studied in terms of its impact on the receiver probability of error. A discussion on the method of optimizing the effect of $n_j(t)$ on the receiver probability of error is now pursued. But, to be able to compare the results of the optimization process, the receiver performance under the assumption of white Gaussian noise only interference should be noted. If no jamming waveform is present (i.e. $n_j(t)=0$.) the term d is zero, and Equation 2.18 becomes

$$P_e = \frac{1}{2} \left\{ \text{ERFC} \left[\sqrt{\frac{2}{N_0 \|s_d\|^2}} \cdot \left[\frac{\|s_d\|^2}{2} - 0 \right] \right] + \text{ERF} \left[\sqrt{\frac{2}{N_0 \|s_d\|^2}} \cdot \left[\frac{\|s_d\|^2}{2} + 0 \right] \right] \right\} . \quad (2.19)$$

By expressing Equation 2.19 in terms of the average energy per bit-- E_b , and the normalized signal cross correlation -- ρ , a more meaningful form is obtained. That is,

$$E_b \doteq \frac{1}{2} \int_0^T [s_0^2(t) + s_1^2(t)] dt = \text{AVG. BIT ENERGY} \quad (2.20)$$

$$\rho \doteq \frac{1}{E_b} \int_0^T s_1(t) s_0(t) dt \quad (2.21)$$

so that

$$\|s_d\|^2 = \int_0^T [s_1(t) - s_0(t)]^2 dt = 2E_b(1-\rho) \quad (2.22)$$

Thus, Equation 2.19 becomes

$$P_e = \text{ERFC} \left[\sqrt{\frac{2E_b(1-\rho)}{N_0 \cdot 2}} \right] \quad (2.23)$$

By noting that

$$2b/N_0 \doteq \text{signal to noise ratio-SNR}$$

Equation 2.23 becomes

$$P_e = \text{ERFC} \left[\sqrt{\text{SNR}(1-\rho)} \right] \quad (2.24)$$

For orthogonal signals, i.e. $\rho \doteq 0.$, Equation 2.24 becomes

$$P_e = \text{ERFC}[\sqrt{\text{SNR}}] \quad (2.25)$$

For antipodal signals, i.e. $\rho = -1$, Equation 2.24 becomes

$$P_e = \text{ERFC}[\sqrt{2 \cdot \text{SNR}}] \quad (2.26)$$

A plot of these mathematical expressions results in the well known probability of error 'waterfall curves' of a binary receiver operating in additive white Gaussian noise.

By evaluating the derivative of Equation 2.18 with respect to the cross correlation between the jammer waveform and the signal difference, d , extremization of the probability of error can be obtained [Ref. 2]. Since

$$\frac{\partial P_e}{\partial d} = \frac{s_q}{\sqrt{2\pi}} \exp[-s_q^2 [N_d^2 + d^2]/2] \text{SINH}(s_q^2 N_d d), \quad (2.27)$$

one notes that due to the behavior of the $\text{SINH}(x)$ function,

$$\frac{\partial P_e}{\partial d} = \begin{cases} > 0 & d > 0 \\ = 0 & d = 0 \\ < 0 & d < 0 \end{cases} \quad (2.28)$$

Thus, P_e is increasing for $d > 0$, and P_e is decreasing for $d < 0$. Therefore, a minimum must exist for the derivative at the point $d=0$. This can be proved by evaluating

$$\frac{\partial^2 P_e}{\partial d^2} = \frac{s_b^3 N_d}{\sqrt{2\pi}} \exp[-s_b^2 (d + N_d)^2 / 2] \quad (2.29)$$

We observe that $\partial^2 P_e / \partial d^2 > 0$ for all values of d . Therefore the minimum P_e must occur at $d=0$. The presence of a jamming waveform will always cause an increase in P_e . Also, by making d as large as possible in magnitude causes an as large as possible increase in P_e . In fact,

$$\lim_{d \rightarrow \infty} P_e = \frac{1}{2} \left\{ \text{ERFC}[s_b [N_d - d]] + \text{ERF}[s_b [N_d + d]] \right\} \quad (2.30)$$

becomes

$$\lim_{d \rightarrow \infty} P_e = \frac{1}{2} \left\{ \text{ERFC}(-\infty) + \text{ERF}(-\infty) \right\} \quad (2.31)$$

or

$$\lim_{d \rightarrow \infty} P_e = \frac{1}{2} \left\{ 1 + 0 \right\} = \frac{1}{2} \quad (2.32)$$

This result makes sense for it states that as the jammer becomes increasingly powerful, the probability of error approaches 1/2. However, the jammer model will be constrained in power as follows

$$|d| = |(N_j, s_d)| \leq \|N_j\| \|s_d\| \quad (2.33)$$

with the inequality due to Cauchy-Schwarz. Defining $\|n_j\| \triangleq \sqrt{P_{n_j}}$, where P_{n_j} is the jammer power, the term $|d| \rightarrow \infty$ implies that $P_{n_j} \rightarrow \infty$ when $\|s_d\| < \infty$. Since it is not possible to have infinite jammer power, P_{n_j} will be constrained to a finite value. From the Cauchy-Schwarz inequality it can be seen that Equation 2.33 can be made into an equality if $n_j(t)$ is directly proportional to $s_d(t)$. That is

$$N_j(t) = K s_d(t) \quad (2.34)$$

where K is a constant of proportionality. Since $\|n_j\| \triangleq \sqrt{P_{n_j}}$, K must be set to the value $\sqrt{P_{n_j}} / \|s_d\|$. The term d can now be maximized by setting

$$N_j(t) = \frac{\sqrt{P_{n_j}} s_d(t)}{\|s_d\|} \quad (2.35)$$

Thus, in order to maximize the receiver probability of error with $n_j(t)$ constrained to have power P_{n_j} , set $n_j(t)$ as given by Equation 2.35. This results in

$$d = (N_j, s_d) = \left(\frac{\sqrt{P_{N_j}} s_d}{\|s_d\|}, s_d \right) \quad (2.36)$$

which reduces to

$$d = \sqrt{P_{N_j}} \|s_d\| \quad (2.37)$$

Equation 2.18 can now be written as

$$P_e = \frac{1}{2} \left\{ \text{ERFC} \left[\sqrt{\frac{2}{N_0}} \cdot \left[\frac{\|s_d\|}{2} - \sqrt{P_{N_j}} \right] \right] + \text{ERF} \left[-\sqrt{\frac{2}{N_0}} \cdot \left[\frac{\|s_d\|}{2} + \sqrt{P_{N_j}} \right] \right] \right\} \quad (2.38)$$

Using the definition of average bit energy- E_b , and signal cross correlation- ρ , Equation 2.38 can be simplified to

$$P_e = \frac{1}{2} \left\{ \text{ERFC} \left[\sqrt{\frac{2}{N_0}} \cdot \left[\sqrt{\frac{2E_b(1-\rho)}{2}} - \sqrt{P_{N_j}} \right] \right] + \text{ERF} \left[-\sqrt{\frac{2}{N_0}} \cdot \left[\sqrt{\frac{2E_b(1-\rho)}{2}} + \sqrt{P_{N_j}} \right] \right] \right\} \quad (2.39)$$

Since $E_b/N_0 = \text{SNR}$, and $P_{N_j}/E_b = \text{JSR}$ (jammer to signal ratio), Equation 2.39 becomes

$$P_e = \frac{1}{2} \left\{ \text{ERFC} \left[\sqrt{\text{SNR}} \left\{ \sqrt{1-p} - \sqrt{2\text{JSR}} \right\} \right] + \text{ERFC} \left[\sqrt{\text{SNR}} \left\{ \sqrt{1-p} + \sqrt{2\text{JSR}} \right\} \right] \right\} \quad (2.40)$$

Analysis of Equation 2.40 highlights the fact that for increasing values of JSR, one limit of integration of the appropriate Gaussian density integral remains always positive, while the other crosses zero and becomes negative. That is $\sqrt{1-p} - \sqrt{2\text{JSR}} < 0$ occurs at $\text{JSR} > (1-p)/2$. When this 'break point' occurs, as SNR increases, P_e worsens. That is, P_e increases to $1/2$ in the limit as $\text{SNR} \Rightarrow \infty$. Jammer strategies can now be attempted using Equation 2.40, and the above noted 'break point' effect will be studied and exploited.

C. DETERMINISTIC JAMMING FOR PSK, FSK, AND ASK MODULATION

The effects of deterministic jamming on various modulation techniques will now be studied. This process will entail the use of a deterministic jammer waveform, and its effect will be evaluated using Equation 2.40 for the following modulation techniques. PSK modulation using

$$S_1(t) = A \cos \omega_c t, \quad S_0(t) = A \cos(\omega_c t + \pi) \quad (2.41)$$

with the constraint that

$$\omega_c T = n\pi \quad n \text{ an integer.}$$

For FSK modulation using

$$S_1(t) = A \cos \omega_1 t, \quad S_0(t) = A \cos \omega_0 t \quad 0 \leq t \leq T \quad (2.42)$$

with the constraint that

$$(\omega_1 - \omega_0) = n\pi/T, \quad (\omega_1 + \omega_0) = m\pi/T \quad n \text{ and } m \text{ integers.}$$

ASK modulation utilizing

$$S_1(t) = A_1 s(t), \quad S_0(t) = A_0 s(t) \quad 0 \leq t \leq T \quad (2.43)$$

where we assume that $\|s\| < \infty$ and for convenience, that $A_1 > A_0$.

Beginning the analysis for the PSK case, one notes that

$$S_d(t) = 2A \cos \omega_c t \quad 0 \leq t \leq T \quad (2.44)$$

and $\|s_d\| = \sqrt{2A^2 T}$. We assume the jammer has power constraint P_n , so as discussed previously, the optimum jammer for PSK is given by Equation 2.35, namely

$$N_j(t) = \sqrt{P_{N_j}} \sqrt{\frac{2}{T}} \cos \omega_c t \quad 0 \leq t \leq T. \quad (2.45)$$

For PSK $\varphi = -1.$, and Equation 2.40 becomes

$$P_e = \frac{1}{2} \left\{ \text{ERFC} \left[\sqrt{2\text{SNR}} \left\{ 1 + \sqrt{\text{JSR}} \right\} \right] + \text{ERC} \left[\sqrt{2\text{SNR}} \left\{ 1 - \sqrt{\text{JSR}} \right\} \right] \right\} \quad (2.46)$$

It can be seen that whenever $\text{JSR} > 1$ in Equation 2.46, P_e will increase with increasing SNR. The value of $\text{JSR} = 1$ is the 'break point' for PSK modulation.

For the case of FSK modulation

$$s_d(t) = 2A \left[\sin\left(\frac{\omega_1 - \omega_0}{2}t\right) \right] \left[\cos\left(\frac{\omega_1 + \omega_0}{2}t\right) \right] \quad 0 \leq t \leq T \quad (2.47)$$

and from the previous assumptions made for FSK signaling,

$$\|s_d\| = \sqrt{A^2 T} \quad (2.48)$$

If the jammer has power constraint P_{n_j} , the optimum jammer for FSK is given by Equation 2.35, namely

$$n_j(t) = \sqrt{\frac{P_{n_j}}{T}} \sin\left(\frac{\omega_1 - \omega_0}{2}t\right) \cos\left(\frac{\omega_1 + \omega_0}{2}t\right) \quad 0 \leq t \leq T. \quad (2.49)$$

It should be noted that $n_j(t)$, the optimum jammer for FSK, is an amplitude modulated waveform with spectral lobes at

half the difference frequency $\omega_d = (\omega_1 - \omega_0)$ and half the sum frequency $\omega_s = (\omega_1 + \omega_0)$. For FSK, $\phi = 0$ and Equation 2.40 becomes

$$P_e = \frac{1}{2} \left\{ \text{ERFC} \left[\sqrt{\text{SNR}} \left\{ 1 + \sqrt{2\text{JSR}} \right\} \right] + \text{ERF} \left[\sqrt{\text{SNR}} \left\{ 1 - \sqrt{2\text{JSR}} \right\} \right] \right\} . \quad (2.50)$$

It can be seen that whenever $\text{JSR} > 1/2$ in Equation 2.50, P_e will increase with increasing SNR. The value of $\text{JSR} = 1/2$ is the 'break point' for FSK modulation, and is typical of -3dB differences in performance between coherent receivers for PSK and FSK [Ref. 3].

For the case of ASK modulation

$$s_d(t) = (A_1 - A_0) s(t) \quad 0 \leq t \leq T \quad (2.51)$$

and

$$\|s_d\| = (A_1 - A_0) \|s\| \quad (2.52)$$

If the jammer has power constraint P_{Nj} , the optimum jammer for ASK, as given in Equation 2.35, becomes

$$N_j(t) = \sqrt{P_{Nj}} \frac{S(t)}{\|S\|} \quad 0 \leq t \leq T \quad (2.53)$$

For ASK, the normalized signal cross correlation is,

$$\rho = \frac{(2A_0 A_1)}{(A_0^2 + A_1^2)} \quad (2.54)$$

By defining $\alpha = (1 - \rho)$ Equation 2.54 can be written in terms of α , where

$$\alpha = \frac{(A_0 - A_1)^2}{A_0^2 + A_1^2} \quad (2.55)$$

so that Equation 2.40 becomes

$$P_e = \frac{1}{2} \left\{ \text{ERFC} \left[\sqrt{\text{SNR}} \left\{ \sqrt{\alpha} + \sqrt{2\text{JSR}} \right\} \right] + \text{ERF} \left[\sqrt{\text{SNR}} \left\{ \sqrt{\alpha} - \sqrt{2\text{JSR}} \right\} \right] \right\} \quad (2.56)$$

For ASK, the 'break point' occurs at $\text{JSR} = \alpha/2$. Because $\alpha < 1$, in terms of 'break point' efficiency PSK is highest with $\text{JSR} = 1$, FSK is next highest with $\text{JSR} = 1/2$, and ASK is lowest with $\text{JSR} < 1/2$.

D. WEIGHTED SIGNAL JAMMERS

With the knowledge that the optimum jammer waveform takes on the mathematical form given by Equation 2.35, a variation on this form can be effected by defining a jammer waveform to be a weighted normalized sum of the signals $s_0(t)$ and $s_1(t)$. That is

$$N_j(t) = \frac{a_1 s_1(t)}{\|s_1\|} + \frac{a_0 s_0(t)}{\|s_0\|} \quad (2.57)$$

This jammer waveform can be shown to obey

$$\|N_j\|^2 = a_1^2 + a_0^2 + 2a_1 a_0 \frac{(s_1, s_0)}{\|s_1\| \|s_0\|} \quad (2.58)$$

Analysis involving this jammer waveform will be applied to PSK and FSK signaling for which $\|s_1\| = \|s_0\|$. Thus, Equation 2.58 can now be written as (using $\|s_1\| = \|s_0\|$)

$$\|N_j\|^2 = a_1^2 + a_0^2 + 2a_1 a_0 \rho \quad (2.59)$$

where ρ = signal cross correlation. Since $|\rho| \leq 1$, it is simple to demonstrate that $\|N_j\|^2$ will be constrained as follows

(2.60)

$$(a_1 - a_0)^2 \leq \|N_j\|^2 \leq (a_1 + a_0)^2$$

For a power constrained jammer waveform the weighting coefficients, a_0 and a_1 , must be chosen so as to satisfy this constraint. The inner product of the jammer waveform and the signal difference, d , (as noted in Equation 2.18) becomes of primary interest. As previously discussed, as d increases, so does P_e . Therefore, for the defined weighted jammer waveform, Equation 2.18 becomes

$$(N_j, s_d) = \frac{a_1}{\|s_1\|} (s_1, s_d) + \frac{a_0}{\|s_0\|} (s_0, s_d) = \|s_1\| (a_1 - a_0) [\perp - \varphi] \quad (2.61)$$

Using Equation 2.18 and the assumption of equal bit energies, $\|s_0\| = \|s_1\|$, the following expression for P_e is obtained,

$$P_e = \frac{1}{2} \left\{ \text{ERFC} \left[\sqrt{\frac{\perp - \varphi}{N_0}} \cdot \left\{ \|s_1\| - (a_1 - a_0) \right\} \right] + \text{ERF} \left[\sqrt{\frac{\perp - \varphi}{N_0}} \cdot \left\{ \|s_1\| + (a_1 - a_0) \right\} \right] \right\} \quad (2.62)$$

Since for equal bit energies,

$$E_b = 1/2 (\|s_1\|^2 + \|s_0\|^2) = \|s_1\|^2$$

Equation 2.62 becomes

$$P_e = \frac{1}{2} \left\{ \text{ERFC} \left[\sqrt{\frac{E_b(1-\rho)}{N_0}} \cdot \left\{ 1 - \frac{(a_1 - a_0)}{\sqrt{E_b}} \right\} \right] + \text{ERF} \left[-\sqrt{\frac{E_b(1-\rho)}{N_0}} \cdot \left\{ 1 + \frac{(a_1 - a_0)}{\sqrt{E_b}} \right\} \right] \right\} \quad (2.63)$$

For PSK modulation, $\rho = -1$, so that Equation 2.59 becomes

$$\|N_j\|^2 = a_1^2 + a_0^2 - 2a_1a_0 \quad (2.64)$$

or,

$$\|N_j\|^2 = (a_1 - a_0)^2 \doteq P_{N_j} \quad (2.65)$$

For $P_{N_j}/E_b \doteq \text{JSR}$, and $E_b/N_0 \doteq \text{SNR}$ Equation 2.63 becomes

$$P_e = \frac{1}{2} \left\{ \text{ERFC} \left[\sqrt{2\text{SNR}} \cdot \left\{ 1 - \sqrt{\text{JSR}} \right\} \right] + \text{ERF} \left[-\sqrt{2\text{SNR}} \cdot \left\{ 1 + \sqrt{\text{JSR}} \right\} \right] \right\} \quad (2.66)$$

Observe that this result is identical to that obtained when $n_j(t)$ is given by Equation 2.45. Since $(a_1 - a_0)^2 \doteq P_{N_j}$, and $\|s_1\|^2 = \|s_0\|^2 = A^2 T / 2 = E_b$, it can be seen that Equation 2.57 becomes

$$N_j(t) = \frac{1}{\sqrt{E_b}} (a_1 - a_0) A \cos \omega_c t = \sqrt{P_{N_j}} \sqrt{\frac{2}{T}} \cos \omega_c t \quad (2.67)$$

which is identical to Equation 2.45. The choice of a_1 and a_0 is not important provided that the power constraint is met, i.e. $(a_1 - a_0)^2 = P_{N_j}$. It must be noted however that if $a_1 = a_0$, $n_j(t) = 0$, and the jammer waveform clearly has no effect.

For FSK, $\rho = 0$, and Equation 2.59 becomes

$$\|N_j\|^2 = a_1^2 + a_0^2 = P_{N_j} \quad (2.68)$$

or,

$$a_0^2 = P_{N_j} - a_1^2 \quad (2.69)$$

Define now the following variables

$$a_{iR} \doteq \frac{a_i}{\sqrt{P_{N_j}}}, \quad i = 0, 1, \quad a_{0R} = \pm \sqrt{1 - a_{1R}^2} \quad (2.70)$$

For the noted power constrained jammer, a real value for a_0 and a_{\perp} must exist, such that the power constraint is satisfied. That is, it must be true that $1 - a_{\perp}^2 \geq 0$. This implies that $|a_{\perp}| \leq 1$. Observe now that from Equation 2.57 that

$$\begin{aligned} a_{\perp} = \pm 1 &\rightarrow a_{0R} = 0; N_j(t) \propto \cos \omega_{\perp} t \\ a_{\perp} = \pm \frac{1}{\sqrt{2}} &\rightarrow a_{0R} = \pm \frac{\sqrt{P_{Nj}}}{\sqrt{2}}; N_j(t) \propto \pm \cos \omega_{\perp} t \pm \cos \omega_0 t \\ a_{\perp} = 0 &\rightarrow a_{0R} = \pm \sqrt{P_{Nj}}; N_j(t) \propto \cos \omega_0 t \end{aligned} \quad (2.71)$$

Each condition on the weighted jammer waveform can be associated with its effect on the FSK modulated waveform. The first condition of Equation 2.71, $a_{\perp} = \pm 1$

can be thought of as 'mark' channel jamming. The second condition, $a_{\perp} = \pm \frac{1}{\sqrt{2}}$

can be thought of as 'mark and space' channel or 'equal' channel jamming. The third case can be thought of as 'space' channel jamming. Using the notation from Equation 2.68, Equation 2.18 becomes

$$\begin{aligned} P_e = \frac{1}{2} \left\{ \text{ERFC} \left[\sqrt{\frac{E_b}{N_0}} \cdot \left\{ 1 + \sqrt{\frac{P_{Nj}}{E_b}} [a_{0R} - a_{\perp}] \right\} \right] + \right. \\ \left. \text{ERF} \left[- \sqrt{\frac{E_b}{N_0}} \cdot \left\{ 1 - \sqrt{\frac{P_{Nj}}{E_b}} [a_{0R} - a_{\perp}] \right\} \right] \right\} \quad (2.72) \end{aligned}$$

In terms of SNR and JSR, Equation 2.72 becomes

$$P_e = \frac{1}{2} \left\{ \text{ERFC} \left[\sqrt{\text{SNR}} \left\{ 1 + \sqrt{\text{JSR}} \left[a_{OR} - a_{LR} \right] \right\} \right] + \text{ERF} \left[-\sqrt{\text{SNR}} \left\{ 1 - \sqrt{\text{JSR}} \left[a_{OR} - a_{LR} \right] \right\} \right] \right\} . \quad (2.73)$$

Equation 2.73 provides a means for studying the effect of varying the weighting coefficients a_{OR} and a_{LR} on the receiver probability of error. Performance becomes obviously a factor of the amount of weighting or on how much each channel is being jammed. From Equation 2.73 one can see that if $(a_{OR} - a_{LR}) = 0$, which implies, $a_{LR} = a_{OR}$, the 'equal' channel jamming case, the jammer waveform has no effect on the probability of error. Due to the requirement that $a_{OR}^2 + a_{LR}^2 = 1$, the 'equal' channel jamming case can occur only when $a_{OR} = a_{LR} = \frac{1}{\sqrt{2}}$. This case of 'equal' channel jamming ineffectiveness can also be surmised by noting that due to the orthogonality conditions imposed on the FSK signals, $d=0$. Thus, under the stated conditions, the jammer is completely ineffective.

From Equation 2.73 one can easily see that jamming the 'space' channel is equivalent to jamming the 'mark' channel. If $a_{OR} = 0$, then by the constraint $a_{OR}^2 + a_{LR}^2 = 1$, $a_{LR} = 1$ and Equation 2.73 becomes

$$P_e = \frac{1}{2} \left\{ \text{ERFC} \left[\sqrt{\text{SNR}} \left\{ 1 + \sqrt{\text{JSR}} \right\} \right] + \text{ERF} \left[-\sqrt{\text{SNR}} \left\{ 1 - \sqrt{\text{JSR}} \right\} \right] \right\} . \quad (2.74)$$

In this case the breakpoint occurs at $\text{JSR}=1$. Compared to the optimum jammer waveform in which the breakpoint for FSK modulation occurred at $\text{JSR}=1/2$, single channel jamming is clearly less effective.

By choosing a combination of weighting coefficients, one can show that 'partial' jamming of both channels tends to be less effective than single channel jamming. Consider

$a_{OR} = \frac{\sqrt{3}}{2}$ and $a_{LR} = \frac{1}{2}$, so that $a_{OR}^2 + a_{LR}^2 = 1$, is satisfied. Then Equation 2.73 becomes

$$P_e = \frac{1}{2} \left\{ \text{ERFC} \left[\sqrt{\text{SNR}} \left\{ 1 + \sqrt{\text{JSR}} \left[\frac{\sqrt{3} - 1}{2} \right] \right\} \right] + \text{ERF} \left[\sqrt{\text{SNR}} \left\{ 1 - \sqrt{\text{JSR}} \left[\frac{\sqrt{3} - 1}{2} \right] \right\} \right] \right\} \quad (2.75)$$

with a breakpoint at $\text{JSR} = \frac{4}{(\sqrt{3} - 1)^2}$, or $\text{JSR} \approx 7.46$. Comparing this to the breakpoint of $\text{JSR} = 1$ for single channel jamming it is evident that single channel jamming is the more effective method.

Note however that for the special case when $a_0 = -a_1$, fixing $a_{LR} = \frac{1}{\sqrt{2}}$, Equation 2.61 becomes

$$d = \|s_1\| (2a_1) [1 - \rho] = 2a_1 \|s_1\| \quad (2.76)$$

and therefore for FSK modulation, (i.e. $\rho = 0$), Equation 2.63 becomes

$$P_e = \frac{1}{2} \left\{ \text{ERFC} \left[\sqrt{\text{SNR}} \left\{ 1 + \sqrt{2\text{JSR}} \right\} \right] + \text{ERF} \left[\sqrt{\text{SNR}} \left\{ 1 - \sqrt{2\text{JSR}} \right\} \right] \right\} \quad (2.77)$$

This equation is identical to the result obtained for the optimum jamming waveform case noted in Equation 2.50. Thus this special case of the weighted signals jammer is also optimum since $n_j(t)$ in this case is identical in form to the optimum jammer given by Equation 2.49.

E. FREQUENCY MODULATED JAMMING

A method of jamming through a frequency band with a 'spot' or deterministic jammer can be modeled using a frequency modulated jammer waveform. The mathematical model used for an FM jammer is

$$N_j(t) = \sqrt{2P_{Nj}} \sin \left[\omega_s t + K_f \int a \cos \omega_j t \, dt \right] \quad 0 \leq t \leq T. \quad (2.78)$$

After integration Equation 2.78 becomes

$$N_j(t) = \sqrt{2P_{Nj}} \sin \left[\omega_s t + \beta \sin \omega_j t + \Theta \right] \quad 0 \leq t \leq T \quad (2.79)$$

where $\beta = K_f \frac{a}{\omega_j}$ and Θ is a deterministic phase angle. The instantaneous jammer waveform frequency is

$$\omega_i(t) = \omega_s + \beta \omega_j \cos \omega_j t \quad (2.80)$$

and covers the frequency range from

$$(\omega_s - \beta \omega_j) \quad \text{to} \quad (\omega_s + \beta \omega_j)$$

as depicted in Figure 5.11. Assume that $\omega_s T = 2\pi l$ and $\omega_j T = 2\pi k$, where l and k are integers. As in previous analyses, in order to determine receiver performance, the parameter $d = (N_j, S_d)$ must be evaluated. From Equation 2.79

$$d = (N_j, S_d) = \int_0^T \sqrt{2P_{N_j}} \sin[\omega_s t + \beta \sin \omega_j t] S_d(t) dt \quad (2.81)$$

where the deterministic phase Θ has been set to zero for computational ease. For PSK and FSK modulation, $S_d(t)$ will be of the form $D \sin \omega_a t$ [Ref. 2 : p. 20]. The integral that will have to be evaluated is of the form

$$(N_j, S_d) = \sqrt{2P_{N_j}} D \int_0^T \sin[\omega_s t + \beta \sin \omega_j t] \sin \omega_a t dt. \quad (2.82)$$

Using trigonometric identities, Equation 2.82 can be expanded as follows

$$(N_j, S_d) = \frac{\sqrt{2P_{N_j}}}{2} D \int_0^T \left\{ \cos[(\omega_s - \omega_a)t + \beta \sin \omega_j t] - \cos[(\omega_s + \omega_a)t + \beta \sin \omega_j t] \right\} dt. \quad (2.83)$$

By using the well known BESSEL function coefficient expansion for each cosine term in Equation 2.83 the following is obtained

$$(N_j, S_d) = \sqrt{\frac{2P_{N_j}}{2}} \int_0^T \left\{ \sum_{N=-\infty}^{\infty} J_N(\beta) \cos [(\omega_s - \omega_a) + N\omega_j] t - \sum_{N=-\infty}^{\infty} J_N(\beta) \cos [(\omega_s + \omega_a) + N\omega_j] t \right\} dt. \quad (2.84)$$

After integration Equation 2.84 becomes

$$(N_j, S_d) = \sqrt{\frac{2P_{N_j}}{2}} \int_0^T \sum_{N=-\infty}^{\infty} J_N(\beta) \left[\frac{\sin [(\omega_s - \omega_a) + N\omega_j] T}{(\omega_s - \omega_a) + N\omega_j} - \frac{\sin [(\omega_s + \omega_a) + N\omega_j] T}{(\omega_s + \omega_a) + N\omega_j} \right] dt. \quad (2.85)$$

For PSK modulation, the bandwidth of the PSK signal can be effectively limited to

$$\left(\omega_c - \frac{4\pi}{T}, \omega_c + \frac{4\pi}{T} \right)$$

as this range contains over 90% of the signal energy. Thus, the upper and lower bounds of the instantaneous frequency discussed in Equation 2.80 can be made to coincide with the signal bandwidth. That is, we set

$$\omega_c - \frac{4\pi}{T} = \omega_s - \beta\omega_j, \quad \omega_c + \frac{4\pi}{T} = \omega_s + \beta\omega_j \quad (2.86)$$

or,

$$\omega_s = \omega_c, \quad \beta\omega_j = \frac{4\pi}{T}.$$

By earlier assumptions, note now that $\beta = \frac{2}{k}$, where the integer k determines the number of times the jammer waveform will sweep the signal band in one bit interval, T . The cross correlation between the jammer waveform and the signal difference, Equation 2.86 can now be written as

$$(N_j, S_d) = \sqrt{2P_{N_j}} AT \sum_{N=-\infty}^{\infty} J_N(\beta) \left[\frac{\text{SIN } N\omega_j T}{N\omega_j T} - \frac{\text{SIN } [2\omega_s + N\omega_j] T}{[2\omega_s + N\omega_j] T} \right] \quad (2.37)$$

for $D=2A$, and $\omega_c = \omega_a = \omega_s$. The term $\text{SINC}(1\omega T)$ will be zero for all integers n , except $n=0$, due to the assumption $\omega T = 2\pi k$. The second term, $\text{SINC}((2\omega_s + n\omega_j) T)$ is also zero, except when

$$n = (-2\omega_s / \omega_j) = (-2 \left[\frac{2\pi k}{T} \right] / \left[\frac{2\pi k}{T} \right]) = (-2k/k) \doteq r$$

One should note that r need not be an integer. From these simplifications Equation 2.87 can now be written as

$$(N_j, S_d) = AT \sqrt{2P_{N_j}} [J_0(\beta) - J_r(\beta)] \quad (2.88)$$

where $J_r(\beta)$ is zero if r is not an integer [Ref. 4 :p. 244]. Since the average bit energy-- $E_b = A^2 T / 2$, and $\text{SNR} = E_b / N_0$ from Equation 2.88 one can derive an expression for the integral limits of Equation 2.18, namely

$$S_q [N_d \pm d] = \sqrt{2\text{SNR}} [L \pm \sqrt{JSR} \{J_0(\beta) - J_r(\beta)\}] \quad (2.89)$$

From Equation 2.89 the receiver performance can be obtained, and is given by

$$P_e = \frac{1}{2} \left\{ \text{ERFC} \left[\sqrt{2\text{SNR}} \left[1 - \sqrt{\text{JSR}} \left\{ J_0(\beta) - J_r(\beta) \right\} \right] \right] + \text{ERF} \left[\sqrt{2\text{SNR}} \left[1 + \sqrt{\text{JSR}} \left\{ J_0(\beta) - J_r(\beta) \right\} \right] \right] \right\} \quad (2.90)$$

The breakpoint associated with the jammer waveform being analyzed when a PSK coherent receiver is used occurs at

$$\text{JSR} = \frac{1}{\left\{ J_0(\beta) - J_r(\beta) \right\}^2} \quad (2.91)$$

The behavior of the breakpoint is highly dependent on several factors, namely the value of β and whether or not r (which is a function of the integers l and k) is an integer. The breakpoint can occur for small or large values of JSR. If r is not an integer the breakpoint will occur at $\text{JSR} = 1/J_0(\beta)^2$. In order to make the jammer as effective as possible it is desirable to have this breakpoint JSR value minimized. This can be accomplished by making β as small as possible, which from the earlier assumption that $\beta \doteq 2/k$ is equivalent to making k as large as possible. Thus for PSK, the greater the frequency with which the jammer sweeps the signal band over the bit interval, the more effective the jammer. This result can be obtained from another point of view. The jammer waveform of Equation 2.78 can be put in the form

$$N_j(t) = \sqrt{2P_{N_j}} \sum_{N=-\infty}^{\infty} J_N(\beta) \cos(\omega_s + N\omega_j)t$$

With $\omega_s = \omega_c$ and $\omega_j = 2\pi k/T$, as $k \rightarrow \infty$,

$$N_j(t) = \sqrt{2P_{N_j}} J_0(0) = \sqrt{2P_{N_j}} \cos \omega_c t$$

where $\lim_{k \rightarrow \infty} \beta = 0$.

The jammer becomes a tone at the carrier frequency which has been demonstrated to be optimum for PSK modulation.

For FSK modulation the analysis is somewhat more complicated. The FSK signal covers approximately the band

$$\left[\omega_0 - \frac{4\pi}{T}, \omega_1 + \frac{4\pi}{T} \right]$$

The midpoint frequency is $\omega_s = 1/2(\omega_1 + \omega_0)$, so the instantaneous jammer band is chosen such that

$$\omega_s - \beta\omega_j = \omega_0 - \frac{4\pi}{T}; \quad \omega_s + \beta\omega_j = \omega_1 + \frac{4\pi}{T}. \quad (2.92)$$

Equivalently this means that

$$\beta\omega_j = \frac{1}{2}(\omega_1 - \omega_0) + \frac{4\pi}{T}. \quad (2.93)$$

For FSK signaling we assume that

$$(\omega_1 - \omega_0) = 2\pi/T, \quad (\omega_1 + \omega_0) = m\pi/T \quad (2.94)$$

where l and m are integers, and as previously discussed $\omega_j T = 2\pi K$. From Equation 2.93 it can be seen that

$$\beta = \left[\frac{1}{2} \left[\frac{e\pi}{T} \right] + \frac{4\pi}{T} \right] \cdot \left[\frac{T}{2\pi k} \right] \quad (2.95)$$

or

$$\beta = \frac{1}{2k} \left[\frac{e}{2} + 4 \right] \quad (2.96)$$

For FSK,

$$s_d(t) = A \sin \omega_1 t - A \sin \omega_0 t \quad (2.97)$$

so that Equation 2.81 becomes

$$(N_j, s_d) = \int_0^T A \sqrt{2 P_{N_j}} \sin [\omega_c t + \beta \sin \omega_j t] \cdot [\sin \omega_1 t - \sin \omega_0 t] \quad (2.98)$$

In this expression for d , the BESSEL function coefficient expansion can be utilized to yield

$$\begin{aligned} (N_j, s_d) = & \sqrt{2 P_{N_j}} \sum_{N=-\infty}^{\infty} J_N(\beta) \left[\frac{\sin \left[\frac{1}{2}(-\omega_1 + \omega_0) + N\omega_j \right] T}{\left[\frac{1}{2}(-\omega_1 + \omega_0) + N\omega_j \right] T} - \right. \\ & \left. \frac{\sin \left[\frac{1}{2}(3\omega_1 + \omega_0) + N\omega_j \right] T}{\left[\frac{1}{2}(3\omega_1 + \omega_0) + N\omega_j \right] T} \right] - \sqrt{2 P_{N_j}} \sum_{N=-\infty}^{\infty} J_N(\beta) \left[\frac{\sin \left[\frac{1}{2}(\omega_1 - \omega_0) + N\omega_j \right] T}{\left[\frac{1}{2}(\omega_1 - \omega_0) + N\omega_j \right] T} - \right. \\ & \left. \frac{\sin \left[\frac{1}{2}(\omega_1 + 3\omega_0) + N\omega_j \right] T}{\left[\frac{1}{2}(\omega_1 + 3\omega_0) + N\omega_j \right] T} \right] \quad (2.99) \end{aligned}$$

Due to the assumptions involving w_L , w_o , and w_j , Equation 2.99 reduces to

$$(N_j, S_d) = \sqrt{2P_{N_j}} \sum_{N=-\infty}^{\infty} T J_N(\beta) \left[\frac{\text{SINC} \pi(2NK - \ell/2)}{\pi(2NK - \ell/2)} - \frac{\text{SINC} \pi(2NK + M + \ell/2)}{\pi(2NK + M + \ell/2)} - \frac{\text{SINC} \pi(2NK + \ell/2)}{\pi(2NK + \ell/2)} + \frac{\text{SINC} \pi(2NK + M - \ell/2)}{\pi(2NK + M - \ell/2)} \right] \quad (2.100)$$

If l is an even integer, Equation 2.100 at most contains four terms. These four terms can exist only if the argument of all SINC functions is zero. The four terms and their respective values of n that make the SINC function arguments zero are as follows [Ref. 2 : p. 23]

$$\begin{aligned} \sqrt{2P_{N_j}} T J_{N_1}(\beta) & \quad N_1 = \ell/4K \\ \sqrt{2P_{N_j}} T J_{N_2}(\beta) & \quad N_2 = -(M + \ell/2)/2K \\ \sqrt{2P_{N_j}} T J_{N_3}(\beta) & \quad N_3 = -\ell/4K \\ \sqrt{2P_{N_j}} T J_{N_4}(\beta) & \quad N_4 = -(M - \ell/2)/2K. \end{aligned} \quad (2.101)$$

By definition of the BESSEL function, the values of n_i , ($i=1,2,3,4$), must be integers. If these values are not integers the associated terms are equal to zero. Once again the effect of the jammer largely depends on the number of sweeps over the band of the FSK signal. From Equation 2.18 one can obtain receiver performance for the l even case as follows

$$P_e = \frac{1}{2} \left\{ \text{ERFC} \left[\sqrt{\text{SNR}} \left\{ 1 + \sqrt{\text{JSR}} (J_{N_1}(\beta) - J_{N_2}(\beta) + J_{N_3}(\beta) - J_{N_4}(\beta)) \right\} \right] + \text{ERF} \left[-\sqrt{\text{SNR}} \left\{ 1 - \sqrt{\text{JSR}} (J_{N_1}(\beta) - J_{N_2}(\beta) + J_{N_3}(\beta) + J_{N_4}(\beta)) \right\} \right] \right\},$$

with the breakpoint occurring at

$$JSR = \frac{1}{\{J_{N_1}(\beta) - J_{N_2}(\beta) + J_{N_3}(\beta) - J_{N_4}(\beta)\}^2} \quad (2.103)$$

Attempts to minimize this value of JSR are not as direct as for the PSK case in which increasing the number of sweeps per bit interval (k) was found to be optimum for jamming purposes. Increasing k will tend to be detrimental, unless the integer relationships stated in Equation 2.101 can be maintained. Since

$$\sum_{N=-\infty}^{\infty} J_N^2(\beta) = 1 \quad (2.104)$$

there exists the possibility that the values of $l, k,$ and m can be chosen to cause the denominator of Equation 2.103 to approach unity, and thus would approach the value of the optimum jammer breakpoint for FSK signaling noted before.

P. NEAR OPTIMUM JAMMERS

It has been shown that a jammer waveform specified by Equation 2.35 is optimum. This conclusion was derived from the implications of the CAUCHY-SCHWARZ inequality as analyzed in section B. The uniqueness of this optimum jammer is however not guaranteed, and therefore the existence of some other jammer waveform, with the same power constraint P_{nj} that maximizes d , is possible. Since, an optimum jammer has been determined, efforts to find other optimum jammers would be redundant in nature. However, it can be demonstrated that simple, effective jammers that obtain near optimum performance can be found. The effect of

these near optimum jammers on PSK and FSK signaling will now be studied.

As a method of jamming, we choose a jammer waveform that is a simple binary signal. Assuming PSK modulation, the signal difference is given by Equation 2.44. Instead of the optimum jammer for PSK noted in Equation 2.45, a near optimum jammer is proposed and defined by

$$N_j(t) = \begin{cases} L & \rightarrow \sin \omega_c t > 0 \\ -L & \rightarrow \sin \omega_c t < 0 \end{cases} \quad 0 \leq t \leq T. \quad (2.105)$$

The jammer power is

$$\|N_j\|^2 = \frac{N\pi L^2}{\omega_c} = P_{N_j} \quad (2.106)$$

with $\omega_c = n\pi/T$, n an integer. From Equation 2.106 it is clear that $L = \sqrt{(P_{N_j} T / \pi)}$. The value of L can now be used in Equation 2.18 to obtain

$$(N_j, S_d) = \int_0^T 2A \sqrt{\frac{P_{N_j}}{T}} |\sin \omega_c t| dt = 2A \sqrt{\frac{P_{N_j}}{T}} \int_0^{\frac{N\pi}{\omega_c}} |\sin \omega_c t| dt = \frac{4}{\pi} \sqrt{P_{N_j} T A} \quad (2.107)$$

Maximizing d produces the largest increase in ρ_e , and for PSK

$$d_{\text{MAX}} = \sqrt{P_{N_j}} A \sqrt{2T} \quad (2.108)$$

When d of Equation 2.107 is compared to d_{MAX} one can see that

$$\frac{d}{d_{\text{MAX}}} = \frac{\frac{4}{\pi} \sqrt{P_{N_j} T} A}{\sqrt{2} \sqrt{P_{N_j} T} A} = \frac{4}{\pi \sqrt{2}} \approx 0.9 \quad (2.109)$$

That is, the simple binary jammer achieves a value of d that is 90% of the optimum value d_{MAX} . The receiver performance can be determined with the aid of Equation 2.19. This yields

$$P_e = \frac{1}{2} \left\{ \text{ERFC} \left[\sqrt{\text{SNR}} \left\{ \sqrt{2} + \frac{4}{\pi} \sqrt{\text{JSR}} \right\} \right] + \text{ERF} \left[\sqrt{\text{SNR}} \left\{ \sqrt{2} - \frac{4}{\pi} \sqrt{\text{JSR}} \right\} \right] \right\} \quad (2.110)$$

From Equation 2.110, the breakpoint occurs at

$$\text{JSR} = \left[\frac{\sqrt{2} \pi}{4} \right]^2 = \frac{\pi^2}{8} \approx 1.23 \quad (2.111)$$

Compared to the optimum case breakpoint of $\text{JSR}=1$, the near optimum jammer waveform yields a breakpoint which is 23% higher.

A similar form of jammer waveform can be applied to FSK signaling however the analysis of the jammer effect on P_e becomes somewhat complicated. A binary jammer signal would be at a constant jammer level ($\pm L$) and interacting against $s(t)$ which for FSK is a sinusoidally varying envelope amplitude modulated signal. The desired jammer effect against the oscillating envelope of $s_d(t)$ would be to use a multi-level jammer. The jammer could then jam at a low level when $s_d(t)$ is maximum, and jam at a high level when $s_d(t)$ is minimum. Such a multi-level jammer would be effective in theory, but difficult to realize in practice. For this reason the near optimum jammer for FSK signaling will not be further analyzed.

G. ADDITIVE NOISE JAMMERS

All previously discussed jammer waveforms have been treated on the basis of a deterministic model. If we assume a jamming waveform $n_j(t)$, where $n_j(t)$ is a sample function of white Gaussian noise process having power spectral density level of $N_j/2$ Watts/Hz, and is statistically independent of the additive noise $n(t)$, the received signal will be of the form

$$r(t) = S_i(t) + N(t) + N_j(t) \quad i = 0, 1 \quad 0 \leq t \leq T \quad (2.112)$$

From Equation 2.8 the conditional mean of the statistic G becomes

$$E\{G/s_i\} = (s_i, s_d) + \frac{1}{2}[\|s_0\|^2 - \|s_1\|^2] \quad (2.113)$$

and the conditional variance becomes

$$\text{VAR}\{G/s_i\} = \left[\frac{N_0 + N_j}{2}\right] \|s_d\|^2 \quad (2.114)$$

Knowing the conditional mean and variance of G , the probability of error (from Equation 2.13), with the assumption of equiprobable signals becomes

$$P_e = \frac{1}{2} \left\{ \text{ERFC} \left[\sqrt{\frac{E_b(L-P)}{N_0 + N_j}} \right] + \text{ERF} \left[-\sqrt{\frac{E_b(L-P)}{N_0 + N_j}} \right] \right\} \quad (2.115)$$

or

$$P_e = \text{ERFC} \left[\sqrt{\frac{E_b(L-P)}{N_0 + N_j}} \right] \quad (2.116)$$

With $\text{SNR} = E_b/N_0$ and $\text{JSR} = N_j/E_b$ Equation 2.116 can be written in the form

$$P_e = \text{ERFC} \left[\sqrt{\frac{\text{SNR}(L-P)}{(L + \text{SNR} \cdot \text{JSR})}} \right] \quad (2.117)$$

From this equation one can note that the term JSR is not isolated by nature. The change in receiver performance with respect to the SNR will provide insight as to the interaction of JSR [Ref. 2 :p. 7]. Thus,

$$\frac{\partial P_e}{\partial \text{SNR}} = \frac{-1}{\sqrt{2\pi}} \frac{\sqrt{1-\rho}}{2\sqrt{\text{SNR}}(1+\text{SNR}\cdot\text{JSR})^{3/2}} \exp\left[\frac{\text{SNR}(1-\rho)}{2(1+\text{SNR}\cdot\text{JSR})}\right] \quad (2.118)$$

and for all values of $\text{SNR} > 0$, and $\text{JSR} > 0$, $\frac{\partial P_e}{\partial \text{SNR}}$ is negative. This clearly means that P_e is a decreasing function for increasing values of SNR, or in other words the receiver performance improves with increasing SNR. In order to understand this behavior, Equation 2.113 and Equation 2.114 must be analyzed. The difference between the additive noise jammer waveform and the deterministic jammer waveform is obviously that the former method influences the variance of G , but not its mean. The effect of the deterministic jammer on the mean of G causes the system performance to be threshold dependent. As the jammer power increases the mean value of G increases to the point that when G is compared to the set threshold, almost always G exceeds the threshold making decision errors almost half the time. For the additive noise jammer such effects do not occur due to the fact that the constant mean of G is unaffected by the jammer power. By this discourse it becomes mathematically evident that additive white Gaussian noise jammer waveforms are considerably less effective than deterministic jammer models of the form of Equation 2.35 when systems operate with a set threshold.

H. VARIABLE THRESHOLDING EFFECTS

It is now clear that when a fixed threshold value is used by the receiver, the effect of the jammer waveform is such that the receiver may be rendered inoperable. It therefore becomes desirable not to set the threshold level to zero, but rather to make it adaptive in nature. By expressing Equation 2.18 in the form

$$P_e = \frac{1}{2} \left\{ \text{ERFC} [s_0 [\gamma + N_d - J_d]] + \text{ERF} [s_0 [\gamma - N_d - J_d]] \right\} \quad (2.119)$$

where

$$J_d \doteq \sqrt{P_{N_j}} \|s_d\|$$

we now can attempt to minimize P_e by an appropriate choice of γ . Evaluating

$$\frac{\partial P_e}{\partial \gamma} = \frac{s_0}{2\sqrt{2\pi}} \left[\exp \left[s_0^2 \left[\gamma - N_d - J_d \right]^2 / 2 \right] - \exp \left[s_0^2 \left[\gamma + N_d - J_d \right]^2 / 2 \right] \right] \quad (2.120)$$

and

$$\frac{\partial^2 P_e}{\partial \gamma^2} = \frac{s_0^3}{2\sqrt{2\pi}} \left[-(\gamma - N_d - J_d) \exp \left[s_0^2 \left[\gamma - N_d - J_d \right]^2 / 2 \right] + (\gamma + N_d - J_d) \exp \left[s_0^2 \left[\gamma + N_d - J_d \right]^2 / 2 \right] \right] \quad (2.121)$$

it becomes simple to show that at $\gamma = J_d$

$$\frac{\partial P_e}{\partial \gamma} \geq 0 \quad , \quad \frac{\partial^2 P_e}{\partial \gamma^2} > 0. \quad (2.122)$$

Thus, P_e is minimum when

$$\gamma = \sqrt{P_{N_j}} \|s_d\| .$$

The receiver normally would have no knowledge of the jammer power and can therefore only estimate the value of P_{N_j} . If the estimate is 'correct', Equation 2.119 becomes

$$P_e = \text{ERFC}[S_q N_d] \quad (2.123)$$

and the effect of the jammer is completely removed. In fact,

$$S_q N_d = \sqrt{\frac{E_b}{N_o} (1 - \rho)}$$

so that Equation 2.123 becomes simply the expression for receiver performance in additive white Gaussian noise. If the estimate of the value of P_{N_j} is 'incorrect', the incorrect value of γ will cause an increase in P_e since $\frac{\partial P_e}{\partial \gamma} > 0$. Thus adaptive thresholding is extremely effective in theory, but due to the receiver's inability to 'know' the jammer power, it is difficult to implement in practice.

III. EFFECTS OF DETERMINISTIC JAMMERS ON M-ARY ORTHOGONAL RECEIVERS

A. M-ARY ORTHOGONAL RECEIVER MODEL

Having studied the effect of deterministic jammer waveforms on binary coherent receivers, the next logical step is to analyze the effect of jammers on an M-ary orthogonal coherent receiver. It has been demonstrated that the use of multiple signals can improve the performance of a digital communication system [Ref. 5 :p. 249]. In fact through the use of multiple signals, or 'M-ary' communication designs, effective use of channel bandwidth and data throughput is obtained. The performance of a coherent M-ary receiver is determined in much the same manner as for the binary coherent receiver. The coherent M-ary receiver utilizing M correlators is known to be optimum for the reception of one of M orthogonal signals in additive white Gaussian noise [Ref. 1 :p. 180]. The corresponding receiver structure is shown in Figure 5.17. This chapter is devoted to investigating the effect on the coherent M-ary correlator receiver performance due to the presence of jamming and additive white Gaussian noise.

The fact that one of M possible signals may be received every T seconds, is expressed in terms of M by hypotheses $H_i, i=(1, \dots, M)$ as follows

$$\begin{aligned} H_1 : r(t) &= S_1(t) + N(t) + N_j(t) \\ H_2 : r(t) &= S_2(t) + N(t) + N_j(t) \\ &\vdots \\ H_i : r(t) &= S_i(t) + N(t) + N_j(t) \\ &\vdots \\ H_M : r(t) &= S_M(t) + N(t) + N_j(t) \end{aligned}$$

Assume furthermore that the signals are orthogonal, have the same energy ($\|s_i\|^2 = E_b$ for all i), and that all signals are equally likely to be transmitted. Using the Kronecker delta notation

$$\delta_{ij} = \begin{cases} 1 & i = j \\ 0 & i \neq j \end{cases} \quad (3.1)$$

the cross correlation between any two signals becomes

$$(s_i, s_j) = \int_0^T s_i(t) s_j(t) dt = E_b \delta_{ij} \quad (3.2)$$

The j th correlator output will be $G_j = (r, s_j)$, with G_j being conditionally Gaussian. Analyzing the conditional statistics of G_j , we have

$$E_i \{G_j\} = E \{G_j / \text{GIVEN } H_i\} \quad (3.3)$$

or equivalently

$$E_i \{G_j\} = E \{G_j / s_i(t) \text{ TRANSMITTED}\} \quad (3.4)$$

Expanding Equation 3.4 results in

$$E_i \{G_j\} = E \{(s_i + N + N_j, s_j)\} = E \{(s_i, s_j) + (N, s_j) + (N_j, s_j)\} \quad (3.5)$$

From Equation 3.2 and due to the fact that $E\{(n, s_j)\} = 0$, Equation 3.5 becomes

$$E_i \{G_j\} = E_b \delta_{ij} + d_j \quad (3.6)$$

where $d_j = (n_j, s_j)$. Similarly the variance is as follows

$$\text{VAR}_i \{G_j\} = \text{VAR} \{G_j / s_i(t) \text{ TRANSMITTED}\} \quad (3.7)$$

which becomes

$$\text{VAR}_i \{G_j\} = E \{(N_j, s_j)^2\} = \frac{N_0}{2} E_b. \quad (3.8)$$

B. RECEIVER PERFORMANCE

The expected value of the product of any two correlator outputs given that $s_i(t)$ was transmitted results in

$$E_i \{G_j G_k\} = E \{ (s_i + N + N_j, s_j) (s_i + N + N_j, s_k) \} \quad (3.9)$$

$$E_i \{G_j G_k\} = E \left\{ \left[(s_i, s_j) + (N, s_j) + (N_j, s_j) \right] \left[(s_i, s_k) + (N, s_k) + (N_j, s_k) \right] \right\} \quad (3.10)$$

Since the noise is zero mean, we obtain

$$E_i \{G_j G_k\} = (s_i, s_j) (s_i, s_k) + (N_j, s_j) (s_i, s_k) + E \{ (N, s_j) (N, s_k) \} + (s_i, s_j) (N_j, s_k) + (N_j, s_j) (N_j, s_k) \quad (3.11)$$

Due to the orthogonality assumptions and the above noted mean and variance expressions, Equation 3.11 reduces to

$$E_i \{G_j G_k\} = E_b^2 \delta_{ij} \delta_{ik} + d_j E_b \delta_{ik} + \frac{N_0}{2} E_b \delta_{jk} + d_k E_b \delta_{ij} + d_j d_k \quad (3.12)$$

From Equation 3.12 the following conditions on $E_i \{G_j G_k\}$ apply for $j \neq k$

$$E_i \{G_j G_k\} = \begin{cases} d_j d_k & i \neq j \quad i \neq k \\ d_j E_b + d_j d_k & i \neq j \quad i = k \\ d_k E_b + d_j d_k & i = j \quad i \neq k \end{cases} \quad (3.13)$$

and for $j = k$

$$E_i \{G_j^2\} = \begin{cases} \frac{N_0}{2} E_b + d_j^2 & i \neq j \\ (E_b + d_j)^2 + \frac{N_0}{2} E_b & i = j \end{cases} \quad .$$

The determination of probability of error can be determined by first evaluating the conditional probability of making a correct decision. That is, if H_i is true, no error is made if $G < g$ for all $j \neq i$, or

$$P\{\text{NO ERROR} / S_i(t) \text{ TRANSMITTED}\} = P\{\text{NO ERROR} / H_i\} = \\ P\{G_j < g_j, j = 1, 2, \dots, i-1, i+1, \dots, M \mid S_i(t) \text{ TRANSMITTED}\} \quad (3.14)$$

This results in

$$P\{\text{NO ERROR} / H_i\} = \int_{-\infty}^{\infty} P\{G_1 < G_i, \dots, G_{i-1} < G_i, G_{i+1} < G_i, \dots, \\ G_M < G_i / H_i \mid G_i = g_i\} f_{G_i}(g_i) dg_i \quad (3.15)$$

where M is the number of orthogonal FSK signals. From the assumption that the correlator output of each of the M channels is statistically independent of any other channel output, or the conditional probability of no error becomes a product of the joint probability functions. Because G_i is a Gaussian random variable $f_{G_i}(g_i)$ is a Gaussian probability density function. Each of these Gaussian probability density functions can be expressed through use of the error function as follows [Ref. 3 :p. 393]

$$P\{G_1 < G_i, \dots, G_{i-1} < G_i, G_{i+1} < G_i, \dots, G_M < G_i / H_i | G_i = g_i\} \quad (3.16)$$

$$= \prod_{\substack{j=1 \\ j \neq i}}^M \text{ERF}\left[\frac{(g_i - d_j)}{\sqrt{N_0 E_b / 2}}\right]$$

The mean and variance of G_i have been presented in Equation 3.6 and Equation 3.8. Thus, Equation 3.15 becomes

$$P\{\text{NO ERROR}\} = \int_{-\infty}^{\infty} \prod_{\substack{j=1 \\ j \neq i}}^M \text{ERF}\left[\frac{(g_i - d_j)}{\sqrt{N_0 E_b / 2}}\right] \cdot \left[\frac{1}{\sqrt{\frac{2\pi E_b N_0}{2}}} \cdot \exp\left[-\frac{(g_i - E_b - d_i)^2}{2 N_0 E_b / 2}\right] \right] dg_i \quad (3.17)$$

With a change of variables this reduces to

$$P\{\text{NO ERROR} / H_i\} = \int_{-\infty}^{\infty} \prod_{\substack{j=1 \\ j \neq i}}^M \text{ERF}\left[y + \frac{(E_b + d_i - d_j)}{\sqrt{N_0 E_b / 2}}\right] \cdot \frac{1}{\sqrt{2\pi}} \exp\left[-\frac{y^2}{2}\right] dy \quad (3.18)$$

This expression for the probability of no error occurring given that $s_i(t)$ was transmitted can be extended to all M channels by

$$P\{\text{NO ERROR}\} = \sum_{i=1}^M P\{\text{NO ERROR} / H_i\} \cdot P\{H_i\} \quad (3.19)$$

For the M equally likely signals case, $P(H_i) = 1/M$. Using Equation 3.19, the M -ary receiver probability of no error becomes

$$P\{\text{NO ERROR}\} = \frac{1}{M} \sum_{i=1}^M \int_{-\infty}^{\infty} \prod_{\substack{j=1 \\ j \neq i}}^M \text{ERF} \left[y + \frac{(E_b + d_i - d_j)}{\sqrt{E_b N_0/2}} \right] \frac{1}{\sqrt{2\pi}} e^{-y^2/2} dy. \quad (3.20)$$

The receiver probability of error becomes

$$P_e = 1 - P\{\text{NO ERROR}\} \quad (3.21)$$

To put this expression in a more workable form define the error function as follows

$$h_{ij} = \left[y + \frac{(E_b + d_i - d_j)}{\sqrt{N_0 E_b/2}} \right] \quad (3.22)$$

and the Gaussian density function as

$$g(y) = \frac{1}{\sqrt{2\pi}} e^{-y^2/2} \quad (3.23)$$

From Equation 3.21 it follows that

$$P_e = 1 - \frac{1}{M} \sum_{i=1}^M \int_{-\infty}^{\infty} \prod_{\substack{j=1 \\ j \neq i}}^M h_{ij}(y) g(y) dy. \quad (3.24)$$

From this general expression for the probability of error of a M-ary FSK receiver, analysis can be performed to study the effect of various jammer waveforms.

C. JAMMER MODEL

To proceed further, several assumptions must be made concerning the jammer waveform. The jammer must satisfy the power constraints imposed, that is

$$P_{N_j} = \|N_j\|^2 \quad (3.25)$$

From the CAUCHY-SCHWARZ inequality, the cross correlation between the jammer and the kth signal will be upper bounded by

$$d_k = (N_j, s_k) \leq \|N_j\| \|s_k\| = \sqrt{P_{N_j} E_b} \quad (3.26)$$

for $(k=1,2,\dots,M)$. From these assumptions, suppose a potential jammer is a weighted sum of the signals, or

$$N_j(t) = \sum_{\ell=1}^M a_\ell s_\ell(t) \quad (3.27)$$

From Equation 3.25 the jammer power must be

$$P_{N_j} = \int_0^T \sum_{\ell=1}^M a_{\ell} s_{\ell}(t) \sum_{N=1}^M a_N s_N(t) dt = \sum_{\ell=1}^M \sum_{N=1}^M a_{\ell} a_N \delta_{\ell N} = \sum_{\ell=1}^M a_{\ell}^2, \dots$$

where $\delta_{\ell N}$ is the KRONECKER delta. Also, note that

$$d_K = \left(\sum_{\ell=1}^M a_{\ell} s_{\ell}, s_K \right) = \sum_{\ell=1}^M a_{\ell} (s_{\ell}, s_K) = a_K E_b \quad K=1 \dots M. \quad (3.21)$$

For the potential weighted sum jammer defined by Equation 3.27, choose first the case of equal signal weighting, or

$$N_j(t) = a \sum_{\ell=1}^M s_{\ell}(t) \quad (3.30)$$

From this, the weighting limitations based on the assumed power constraint follows from

$$P_{N_j} = M a^2 \rightarrow a = \sqrt{P_{N_j}/M} \quad (3.31)$$

$$d_K = a E_b \quad K=1, \dots, M \quad (3.32)$$

The argument of the error function based on Equation 3.22 is

$$h_{ij}(y) = \text{ERF} \left[y + \frac{(E_b + aE_b - aE_b)}{\sqrt{N_0 E_b / 2}} \right] \quad (3.33)$$

and it is evident that the effect of the jammer cancels out. This can be stated for the general case as

$$h_{ij}(y) = \text{ERF} \left[y + \sqrt{\frac{E_b}{2N_0}} [1 + a_i - a_j] \right] \quad (3.34)$$

such that if $a_i = a_j$ for all i and j , then

$$h_{ij} = \text{ERF} \left[y + \sqrt{\frac{E_b}{2N_0}} \right] \quad (3.35)$$

and P_e becomes

$$P_e = 1 - \frac{1}{M} \int_{-\infty}^{\infty} \left[\prod_{j=1}^M h_{1j}(y) + \prod_{j=1}^M h_{2j}(y) + \dots + \prod_{j=1}^M h_{mj}(y) \right] \cdot \quad (3.36)$$

$$\frac{g(y) dy}{\text{ERF} \left[y + \sqrt{\frac{E_b}{2N_0}} \right]}$$

This expression is simply the probability of error equation for M orthogonal signals with no jamming present [Ref. 5 :p. 221]. From this analysis one can clearly see that 'equal' channel jamming for M-ary orthogonal FSK signaling is ineffectual.

As another potential jammer, $n_j(t)$ is chosen to take on the form

$$n_j(t) = a s_1(t) \quad (3.37)$$

with power constraint

$$P_{N_j} = \|n_j\|^2 = \|a s_1\|^2 = a^2 E_b \quad (3.38)$$

which implies

$$a = \sqrt{P_{N_j} / E_b} \quad (3.39)$$

The jammer cross correlation with the kth signal is

$$d_k = (n_j, s_k) = (a s_1, s_k) = a E_b \delta_{1k} = \begin{cases} \sqrt{P_{N_j} E_b} & K=1 \\ 0 & K=2, \dots, M \end{cases} \quad (3.40)$$

The effect of the jammer is such that it causes a change in the statistics of that channel only (i.e. G_1). That is

$$\prod_{\substack{j=1 \\ j \neq 1}}^M h_{1j}(y) = \left[\text{ERF} \left[\frac{(E_b + \sqrt{P_{N_1} E_b})}{\sqrt{N_0 E_b / 2}} \right] \right]^{M-1} \quad (3.41)$$

$$\begin{aligned} \prod_{\substack{j=1 \\ j \neq 2}}^M h_{2j}(y) &= \text{ERF} \left[y + \frac{(E_b - \sqrt{P_{N_1} E_b})}{\sqrt{N_0 E_b / 2}} \right] \left[\text{ERF} \left[y + \frac{E_b}{\sqrt{N_0 E_b / 2}} \right] \right]^{M-2} \\ &= \prod_{\substack{j=1 \\ j \neq 3}}^M h_{3j}(y) = \prod_{\substack{j=1 \\ j \neq 4}}^M h_{4j}(y) = \dots = \prod_{\substack{j=1 \\ j \neq M}}^M h_{mj}(y). \end{aligned} \quad (3.42)$$

Substituting $\text{SNR} = E_b / N_0$ and $\text{JSR} = P_{N_1} / E_b$, the receiver probability of error for single channel jamming becomes

$$\begin{aligned} P_e &= 1 - \frac{1}{M} \int_{-\infty}^{\infty} \left\{ \text{ERF} \left[y + \sqrt{2\text{SNR}} (1 + \sqrt{\text{JSR}}) \right] \right\}^{M-1} + \\ &\quad (M-1) \text{ERF} \left[y + \sqrt{2\text{SNR}} (1 - \sqrt{\text{JSR}}) \right] \cdot \left[\text{ERF} \left[y + \sqrt{2\text{SNR}} \right] \right]^{M-2} \left. \right\} g(y) dy \end{aligned} \quad (3.43)$$

with the same expression resulting if any one of the other $M-1$ signals had been chosen as the basis for the jammer. Studying the asymptotic behavior of Equation 3.43 one notes that as $\text{SNR} \rightarrow \infty$, and $\text{JSR} < 1$, then

$$P_e \approx 1 - \frac{1}{M} \int_{-\infty}^{\infty} [1 + M-1] g(y) dy = 0. \quad (3.44)$$

Thus as SNR increases, the probability of error increases. Now, when JSR > 1, the asymptotic behavior becomes

$$P_e \approx 1 - \frac{1}{M} \int_{-\infty}^{\infty} g(y) dy - 0 = 1 - \frac{1}{M} . \quad (3.45)$$

This result is worthy of note. For the case of $M=2$, (i.e. binary FSK), P_e tends to $1/2$ as SNR increases. This is exactly the behavior noted in the previous results for binary FSK signaling. As M increases, the jammer has a more devastating effect in that the probability of error for JSR > 1 approaches unity with increasing SNR.

From the analysis performed one can see that a multitude of jamming strategies are possible. Consider, for example, weighted signals jamming for the case of unequal weighting. We have shown that the equal weighting case is ineffectual as a jammer, however by weighting the signals in such a manner to insure unequal weighting may prove to be an effective method of jamming an M -ary correlator receiver, as the previous results have demonstrated for one particular case.

IV. DESCRIPTION OF GRAPHICAL RESULTS

A. DISCUSSION ON GRAPHICAL RESULTS

This chapter presents graphical results related to the analysis of the previous chapters. The plots are intended to display receiver performance as a function of SNR for various jammer waveforms and set JSR values. The plots feature the case of JSR=0 as part of each curve in order to allow comparisons of the jammer effectiveness to the receiver performance for additive white noise only interference.

B. OPTIMUM JAMMERS

The graphical results for the optimum jammer are presented first. These were obtained through numerical evaluation of Equation 2.13. Plots of P_e were generated for the cases of PSK, FSK, and ASK modulation, as a function of SNR and fixed values of JSR using a jammer as specified in Equation 2.18. Specifically the case of PSK modulation is depicted in Figure 5.5. This plot clearly shows the 'breakpoint' phenomena as JSR increases to a value of one or greater. For JSR values greater or equal to one, P_e is clearly driven with increasing SNR to the value of $1/2$ in the limit. From this figure one can note that 10.2dB of SNR is required to obtain a P_e of 10^{-6} at a JSR value of 0.0. In comparison, it takes 14dB of SNR to obtain the same P_e for a JSR value of 0.1. Figure 5.6 corresponds to the FSK case and shows a similar result except that the breakpoint occurs at JSR=1/2, which as previously noted concurs with the -3dB difference between PSK and FSK correlator receivers. From Figure 5.6 it is clear that for the FSK case, it takes less

jammer power to render the receiver inoperative than for the PSK case. In comparison, note that a 13dB SNR is required to obtain a P_e of 10^{-6} for a JSR value of 0.0. The same P_e is obtained by increasing the SNR to 13dB for a JSR of 0.1. For ASK modulation the results are obtained through Equation 2.56 and are presented in Figure 5.7. In comparison, note that to obtain a P_e of 10^{-6} a 10.2dB SNR is required for a JSR value of 0.0. For the same P_e a increase of SNR to 14dB is required for a JSR value of 0.1. The JSR breakpoint for ASK occurs at $\alpha/2$ which is upper bounded by $1/2$. One should note that the actual jammer waveform $N_j(t)$ is different for each of the optimum jammer cases presented. The similarities between the SNR required for PSK and ASK are due to the fact that the 'worst case' condition for the jammer was assumed, namely $\alpha=1/2$. For this case, ASK and PSK are identical modulation schemes. The above comparison reveals that PSK is somewhat less vulnerable to jamming.

C. WEIGHTED SIGNAL JAMMERS

For weighted signal jamming the results of Equation 2.63 are applied to PSK modulation with the aid of Equation 2.67 and to FSK modulation with the aid of Equation 2.73. Immediately one can note that the result of weighted signal jamming on PSK modulation is equivalent to the optimum jamming case, and presented in Figure 5.8. For the FSK case it was shown that the 'equal' channel jammer was ineffective. It was also shown that for a special set of circumstances, the weighted signals jammer is equivalent to the optimum jammer for FSK. These two cases will therefore not be presented. The graphical results for the 'single' channel or 'mark' channel only (or 'space' channel only) jamming are depicted in Figure 5.9. These results of single channel jamming clearly show it to be more effective than the case

of partial channel jamming depicted in Figure 5.10. These graphical results are significant, especially for the constrained power jammer. From these plots it becomes intuitive that it is 'better' to concentrate jammer power on either the 'mark' or 'space' channel frequency, than to attempt to partially jam both channels. For the one channel jamming case shown in Figure 5.9 note that to obtain a P_e of 10^{-6} a value of 13dB SNR is required for a JSR value of 0.0. In comparison for the same P_e note that a SNR of 16dB is required for a JSR of 0.1. For the partial jamming case shown in Figure 5.10 to obtain a P_e of 10^{-6} a value of 14dB SNR is required for a JSR value of 0.0. To obtain the same P_e a value of 15dB SNR is required for a JSR value of 0.1.

D. FREQUENCY MODULATED JAMMERS

Figure 5.11 presents the nature of the frequency modulated jammer waveform. Figure 5.12 shows the effect of the linear FM sweep jammer on PSK modulation. The FM jammer was designed to sweep the bandwidth occupied by the signal. By varying the number of times the jammer sweeps the signal bandwidth during a bit interval the effectiveness of the jammer can be investigated. Figure 5.12 shows the result for one sweep of the jammer per bit interval. Figure 5.13 shows the result for a PSK modulated signal swept twice during the bit interval. For PSK modulation it is clear that as the number of sweeps increases the more effective the jammer. Figure 5.14 and Figure 5.15 show the similar result for FSK modulation. Note however, that in general the added complexity of FM jammer waveforms make it an unlikely candidate for replacement of the optimum jammer. In comparison for PSK modulation as depicted in Figure 5.12 to obtain a P_e of 10^{-6} a value of 13dB SNR is required for a JSR value of 0.0. To obtain the same P_e an increase in SNR to a value of

15dB is required for a JSR of 0.1. For the case of two sweeps per period as shown in Figure 5.13 to obtain a P_e of 10^{-6} a value of 12dB is required for a JSR value of 0.0. To obtain the same P_e an increase in SNR to a value of 13dB is required for a JSR value of 0.1. For FSK modulation as depicted in Figure 5.14 to obtain a P_e of 10^{-6} a value of 15dB SNR is required for a JSR of 0.0. To obtain the same P_e an increase in SNR to a value of 17dB is required for a JSR value of 0.1. For the case of two sweeps per period as shown in Figure 5.15 to obtain a P_e of 10^{-6} a value of 15dB SNR is required for a JSR of 0.0. To obtain the same P_e an increase in SNR to a value of 16dB is required for a JSR of 0.1.

E. NEAR OPTIMUM JAMMERS

Near optimum jamming featured a two level pulsed jammer waveform. The graphical results of Figure 5.15 shows that the breakpoint occurs at JSR= 1.23. This jammer is a good candidate as a substitute for the optimum jammer due to the noted fact that a small increase in JSR over the optimum required JSR results in a marked increase in receiver P_e , without a marked increase in waveform complexity. For the near optimum jammer case depicted in Figure 5.16 to obtain a P_e of 10^{-6} a value of 10dB SNR is required for a JSR of 0.0. To obtain the same P_e an increase in SNR to the value 13dB is required for a JSR of 0.1.

F. M-ARY RECEIVERS GRAPHICAL RESULTS

The graphical results for M-ary FSK receivers were derived from a numerical evaluation of Equation 3.24. It was noted that the case of equal jamming was ineffective and thus will not be presented. The case of single channel jamming of a M-ary coherent correlator receiver is presented in Figure 5.18, for M=2 or binary FSK. The result is

identical to that presented previously. As the number of channels (M) is increased one can clearly see the breakpoint shifting. As discussed in chapter three, if $JSR < 1$, as M increases the receiver performance is clearly affected. Figure 5.19 shows this for $M=10$, and Figure 5.20 similarly for $M=100$. In comparison to obtain a value of P_e of 10^{-6} for the case of $M=2$, depicted in Figure 5.13, a value of 13dB SNR is required for a JSR value of 0.0. To obtain the same P_e an increase in the value of SNR to 19dB is required for a JSR value of 0.2. For the case of $M=10$ depicted in Figure 5.19 to obtain a value of P_e of 10^{-6} a value of 14dB SNR is required for a JSR value of 0.0. To obtain the same P_e an increase in the value of SNR to 19dB is required for a JSR value of 0.2. For the case $M=100$ depicted in Figure 5.20 to obtain a value of P_e of 10^{-6} a value of 15dB is required for a JSR value of 0.0. To obtain the same P_e an increase in value of SNR to 19dB is required for a JSR value of 0.2.

V. CONCLUSION

In this thesis, a known optimum receiver has been analyzed under the usual signal plus noise environment, in addition to jamming. The analysis of the effectiveness of jammer waveforms was undertaken using the receiver probability of error as a measure of performance. The main objective was to maximize the receiver probability of error as a function of a power constrained jammer waveform. Various jammer strategies that affected receiver performance were obtained, and results presented.

For the mathematical models of the various jammer waveforms studied, it was concluded that the optimum jammer waveform consisted of a deterministic signal proportional to the difference of the binary signals used. This method whether applied to PSK, FSK, or ASK modulation techniques drove the receiver probability of error to $1/2$ in the limit, rendering the receiver inoperable. Other jamming strategies attempted included weighted signals, frequency modulated, and near optimum jammers. All these methods of jamming resulted in a similar effect. They drove the receiver performance to an unsatisfactory limit, but with a lesser degree of effectiveness in terms of JSR as compared to the optimum jammer. The sole non-deterministic jamming strategy attempted, additive white Gaussian noise proved less effective.

A M-ary orthogonal signaling coherent receiver was then analyzed in terms of receiver P_e in the presence of signal, noise, and a jamming waveform. It was shown that equal channel jamming on all M channels was ineffective. Single channel jamming was concluded to be a more effective jamming method for the receiver studied. It was further concluded

that the greater the number of channels in the M-ary receiver the more effective the jammer is when the JSR exceeds unity.

From this knowledge of the behavior of a coherent correlator receiver in the presence of jamming it is hoped that a greater understanding of jammer and receiver designs can be achieved.

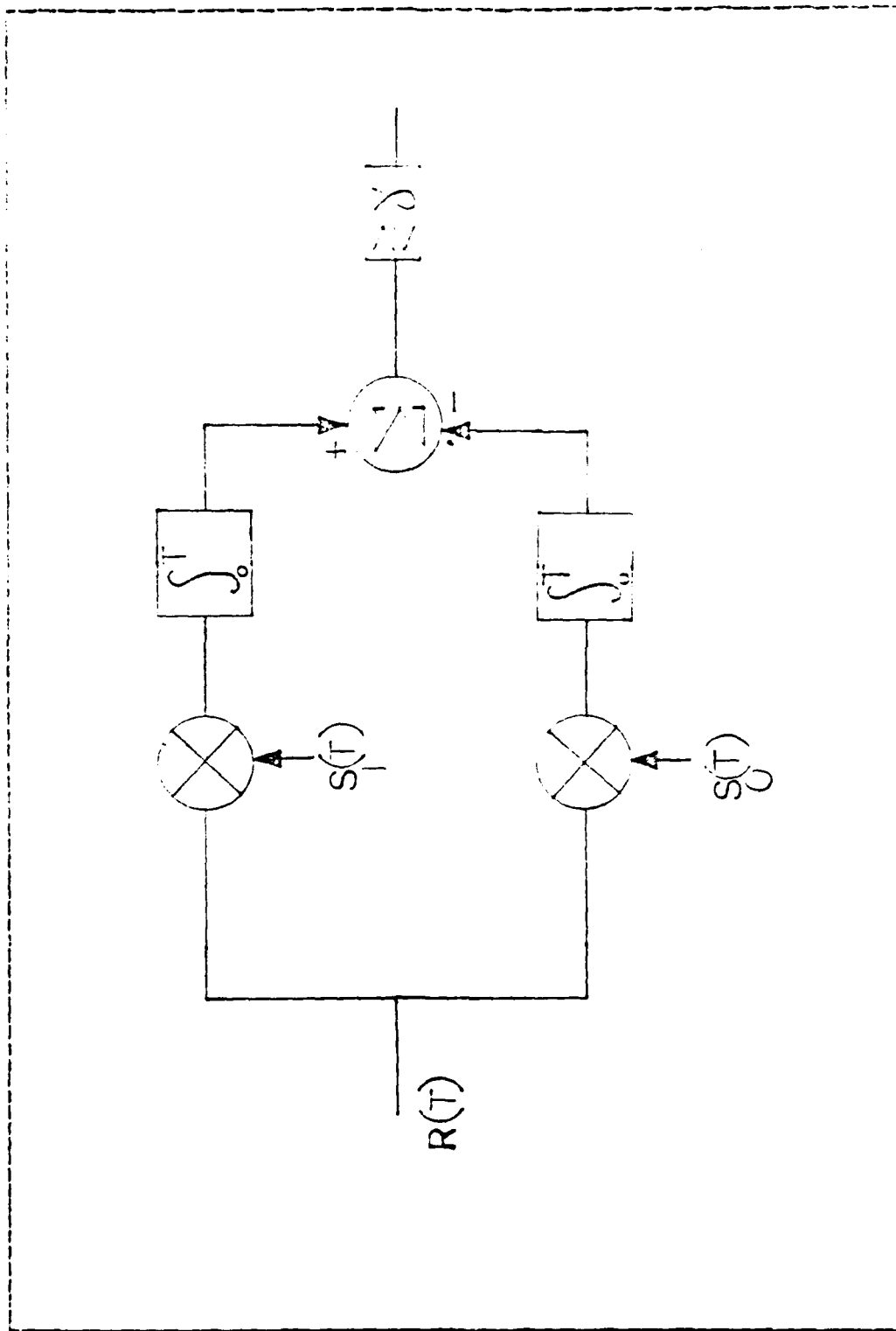

Figure 5.1 Coherent Correlator Receiver.

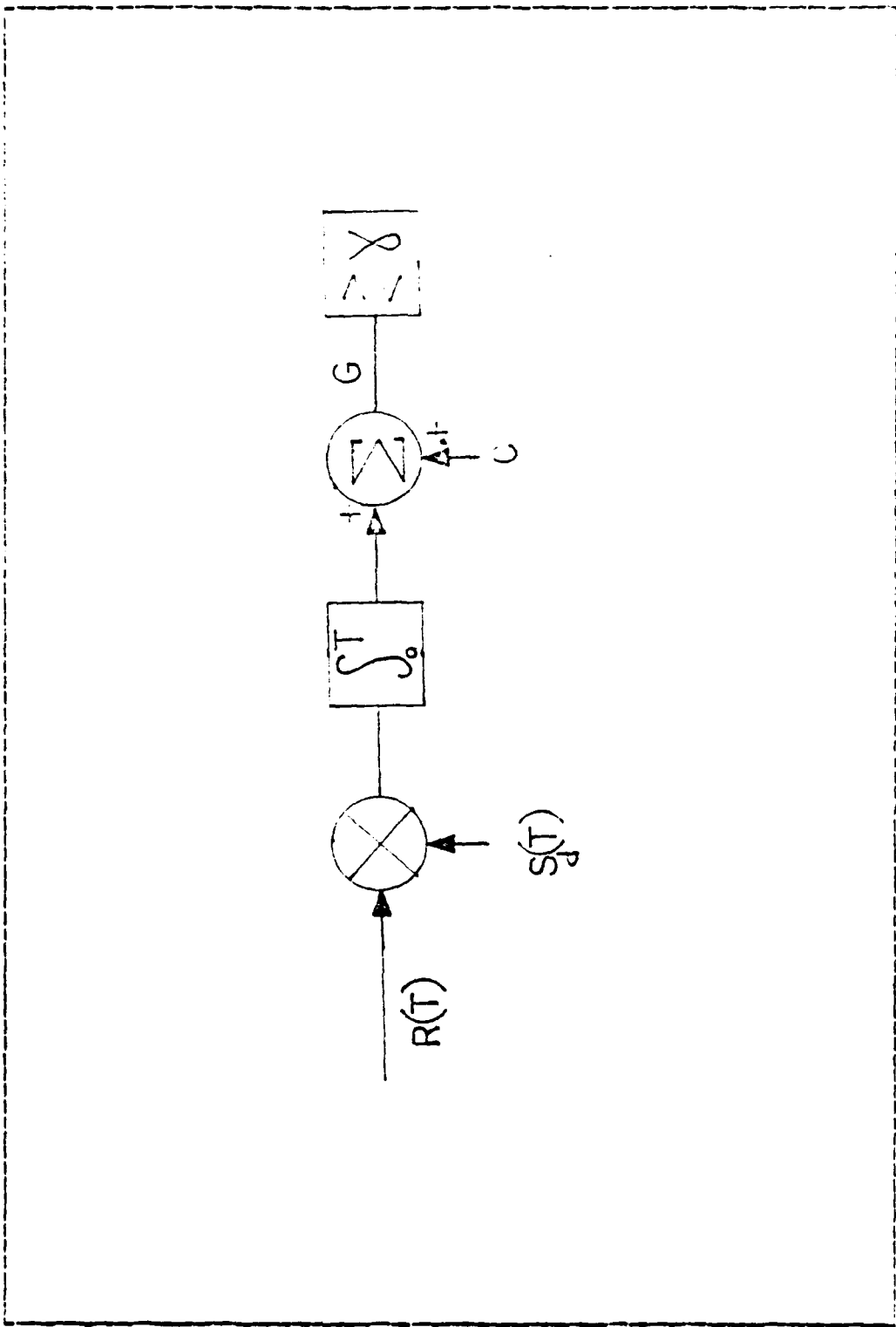

Figure 5.2 Single Correlator Coherent Receiver.

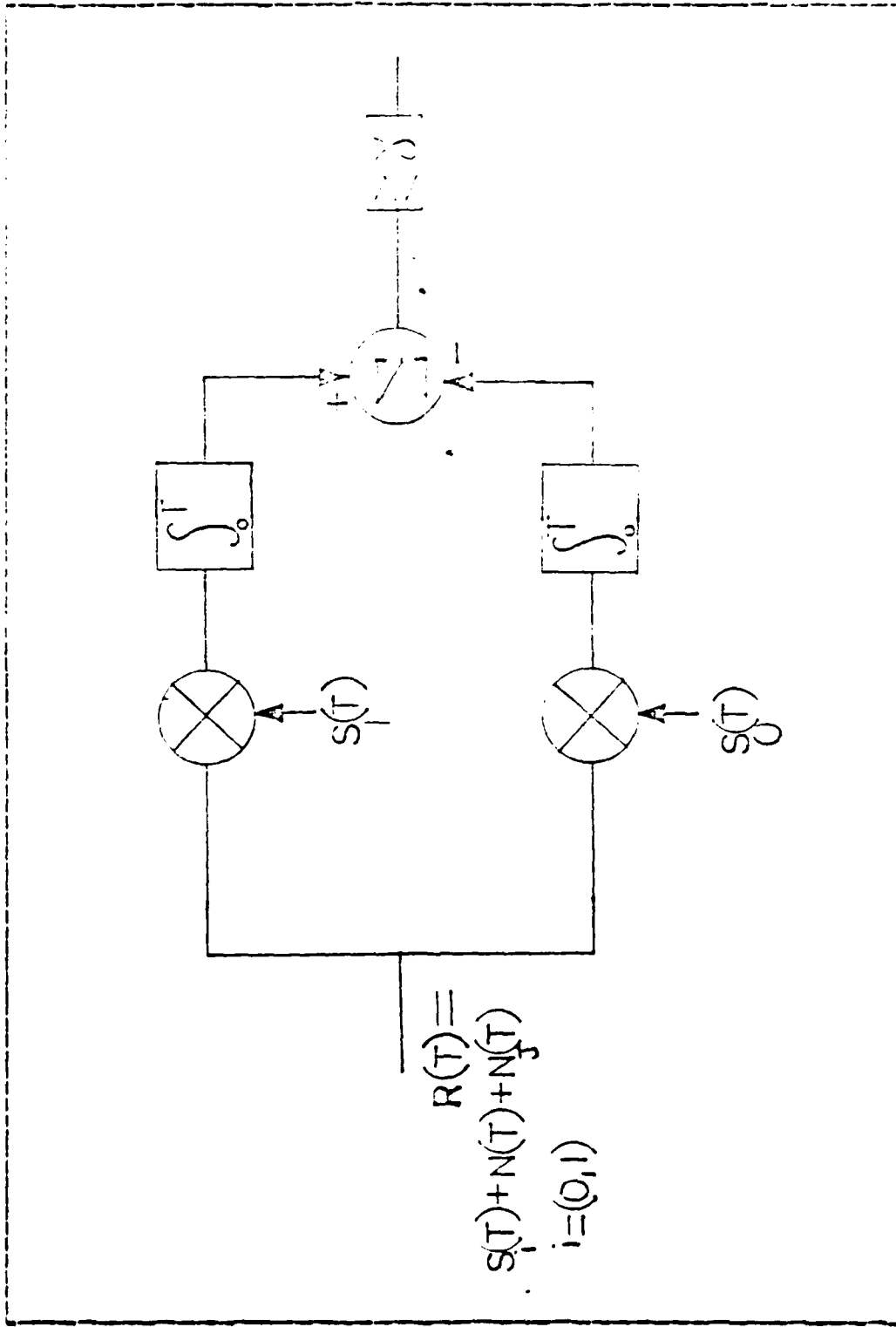

Figure 5.3 Coherent Correlator Receiver in a Jamming Environment.

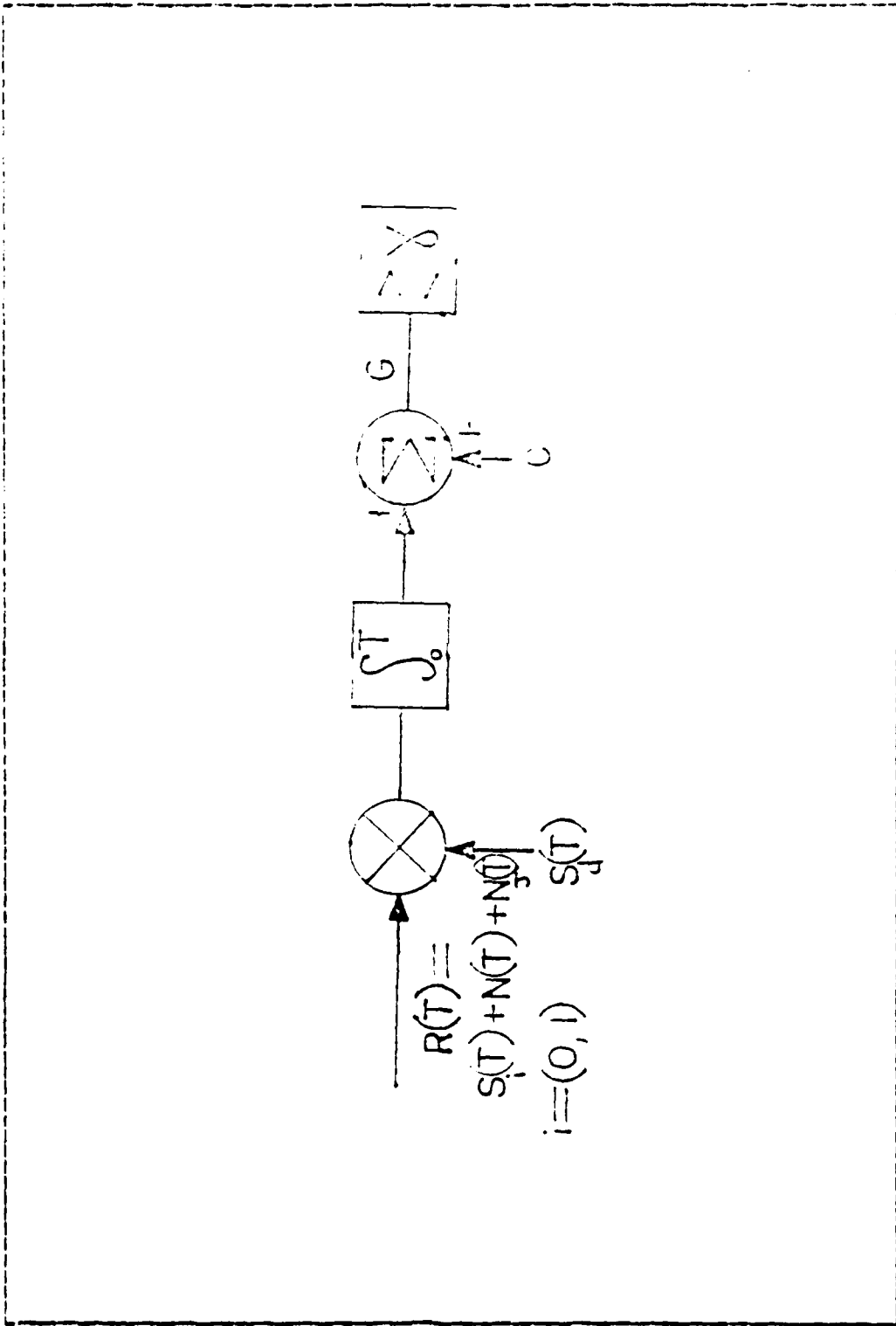

Figure 5.4 Single Correlator Receiver in a Jamming Environment.

PSK WITH DETERMINISTIC JAMMING

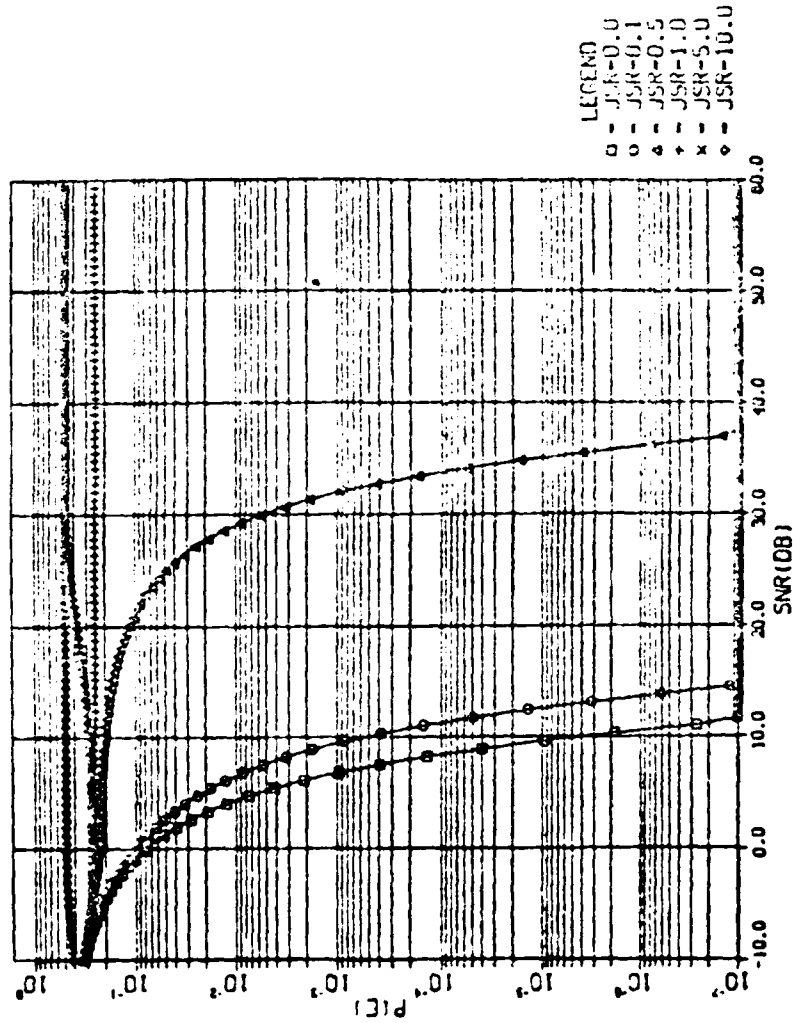

Figure 5.5 Optimum Jammer for PSK Modulated Signal.

FSK W/ DETERMINISTIC JAMMING

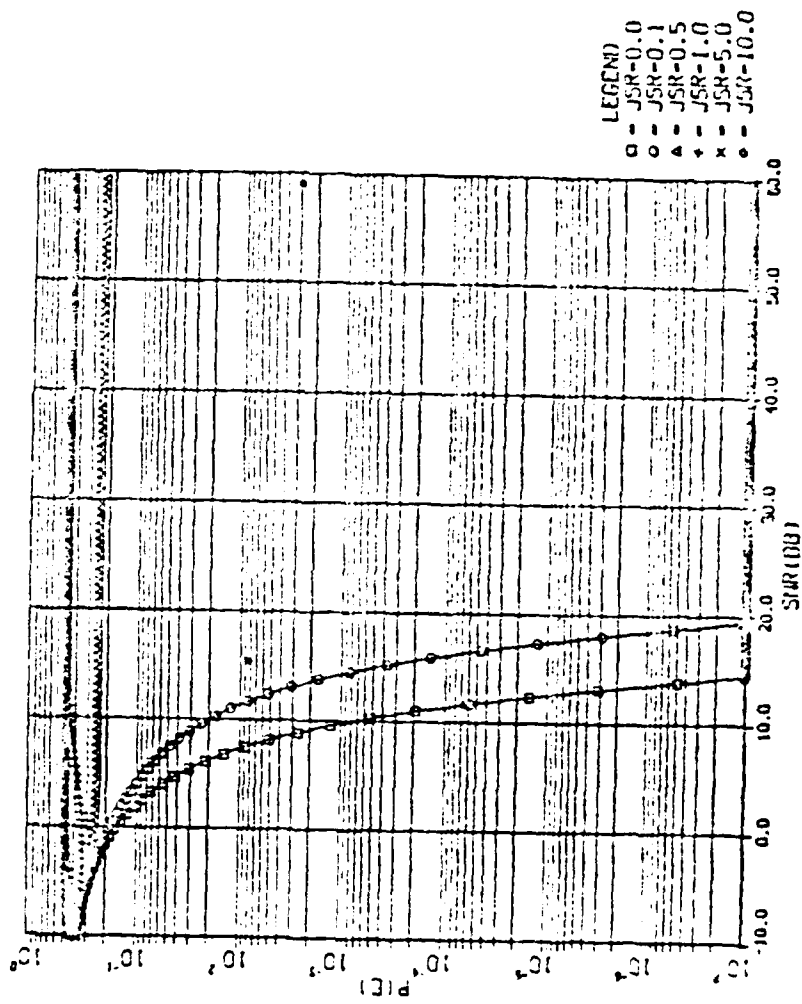

Figure 5.6 Optimum Jammer for FSK Modulated Signal.

ASK WITH DETERMINISTIC JAMMING

ALPHA=2.0

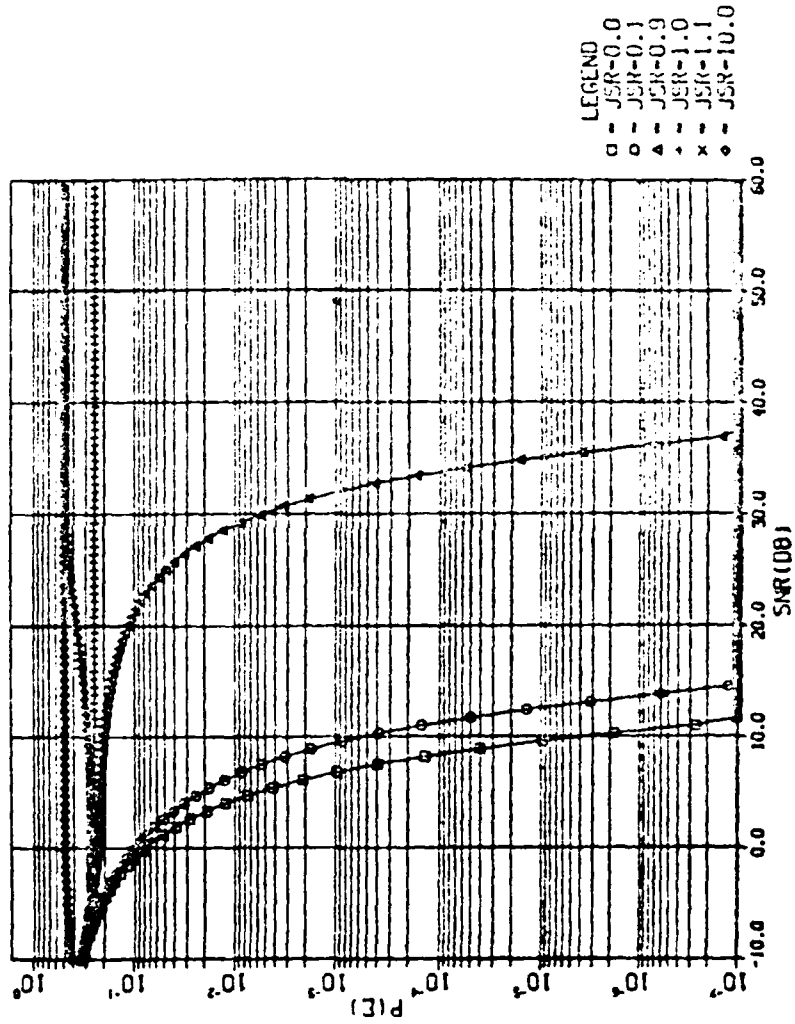

Figure 5.7 Optimum Jammer for ASK Modulated Signal.

PSK W/ WEIGHTED JAMMING

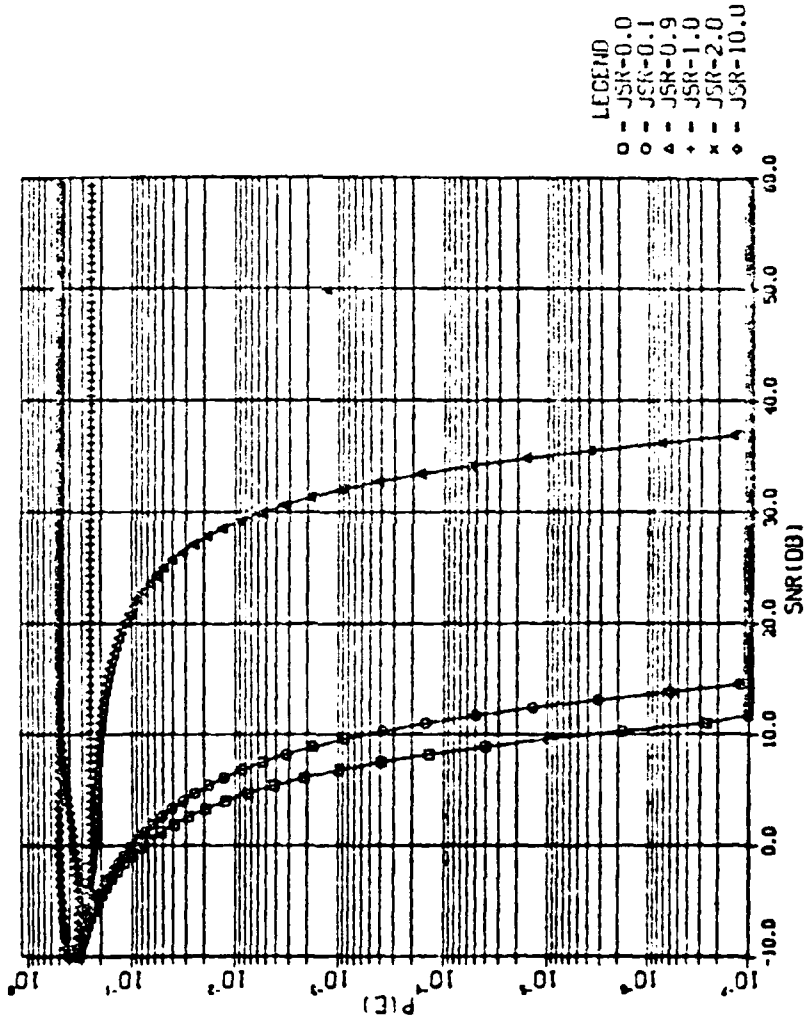

Figure 5.8 Weighted Signals Jammer for PSK Modulated Signal.

FSK W/ WEIGHTED JAMMING

ADR=0.0, AIR=1

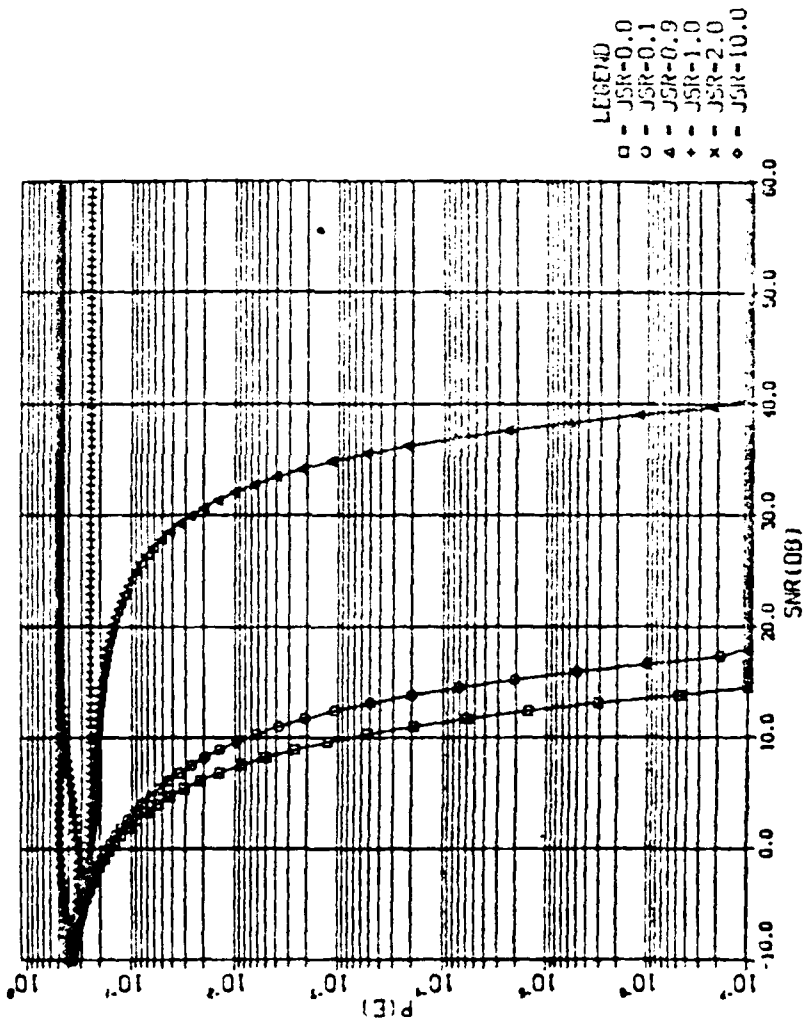

Figure 5.9 One Channel Jam Weighted Signals for FSK Modulation.

FSK W/ WEIGHTED JAMMING

ROR-SORT(3.01/2, AIR-1/2)

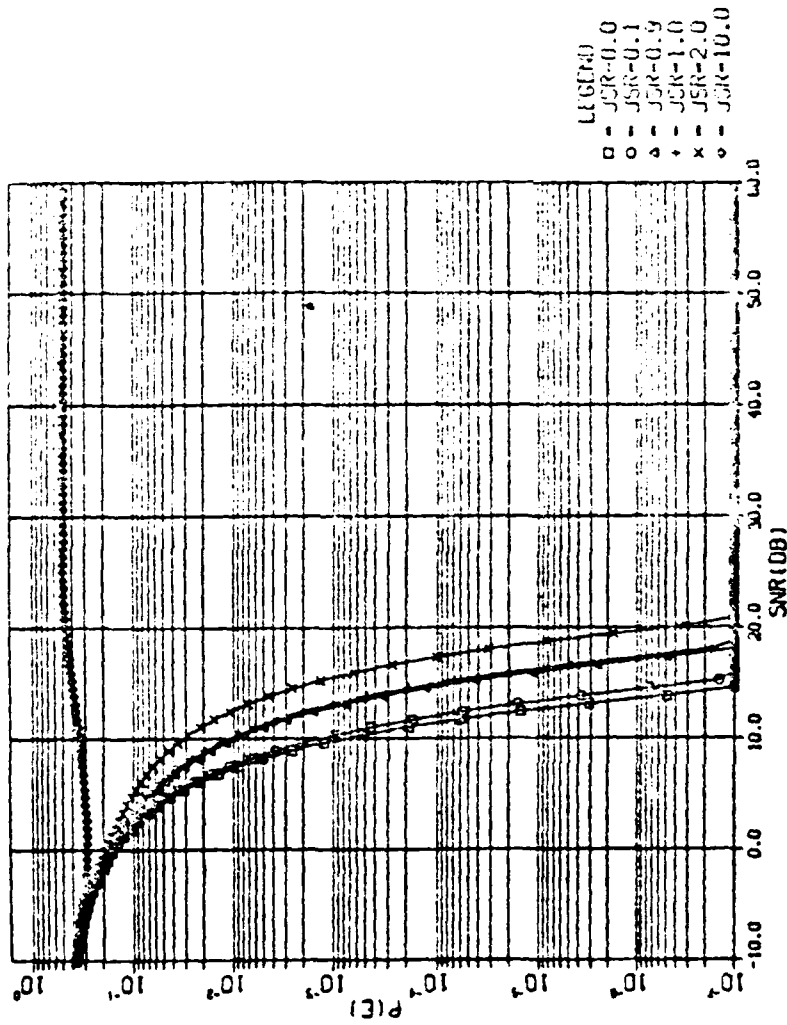

Figure 5.10 Partial Channel Jam Weighted Signals for FSK Modulation.

FREQUENCY MODULATED JAMMER

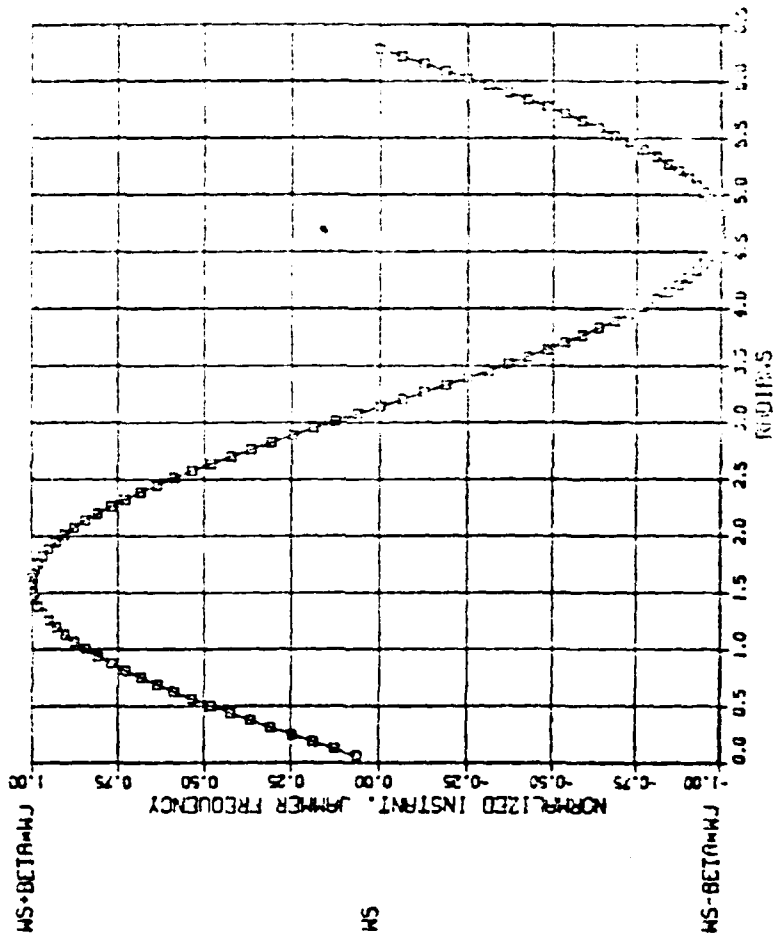

Figure 5.11 Frequency Modulated Jammer.

PSK WITH LINEAR FM JAMMING

CASE #1 ONE SWEEP/CYCLE (K-11)

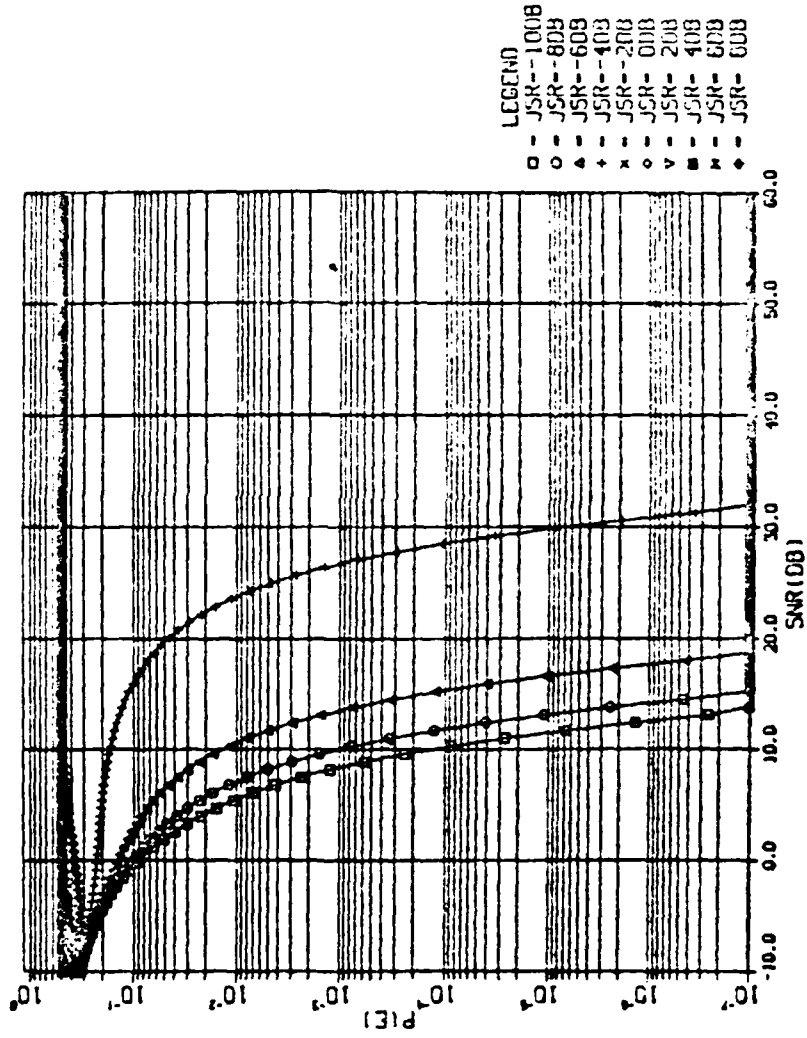

Figure 5.12 Frequency Modulated Jammer for PSK Modulated Signal.

PSK WITH LINEAR FM JAMMING

CASE #2 TWO SWEEPS/CYCLE (K=2)

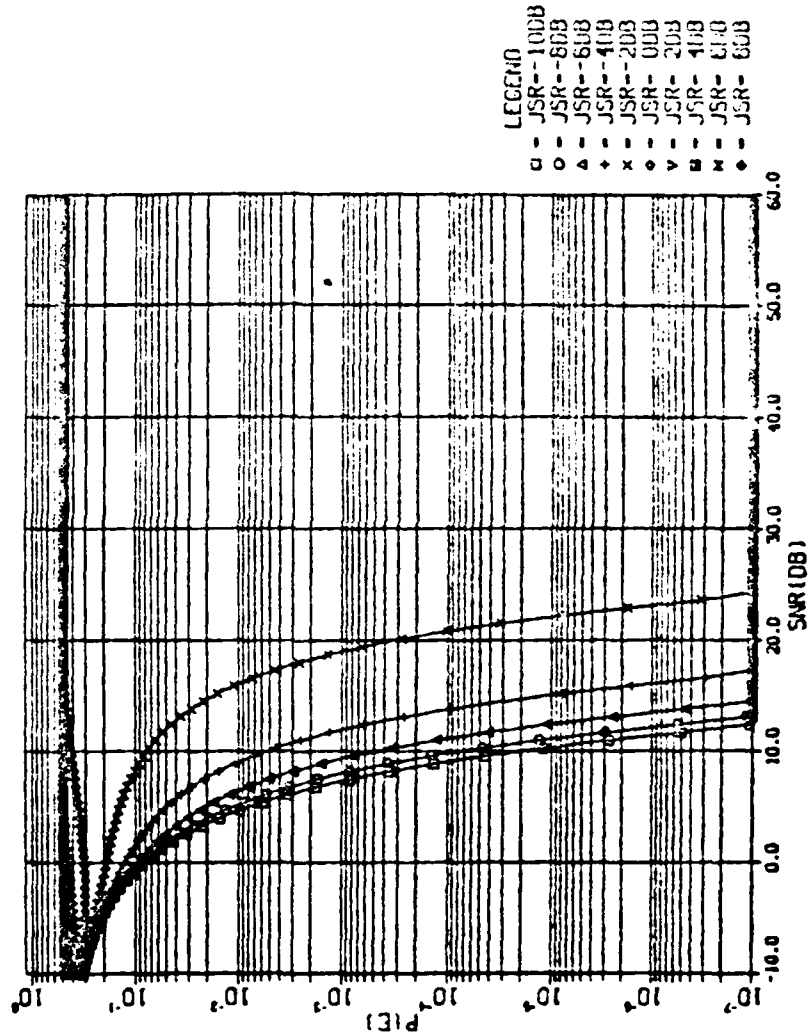

Figure 5.13 Frequency Modulated Jammer for PSK Modulated Signal.

FSK WITH LINEAR FM JAMMING

CASE #1 ONE SWEEP/CYCLE (K=1.1)

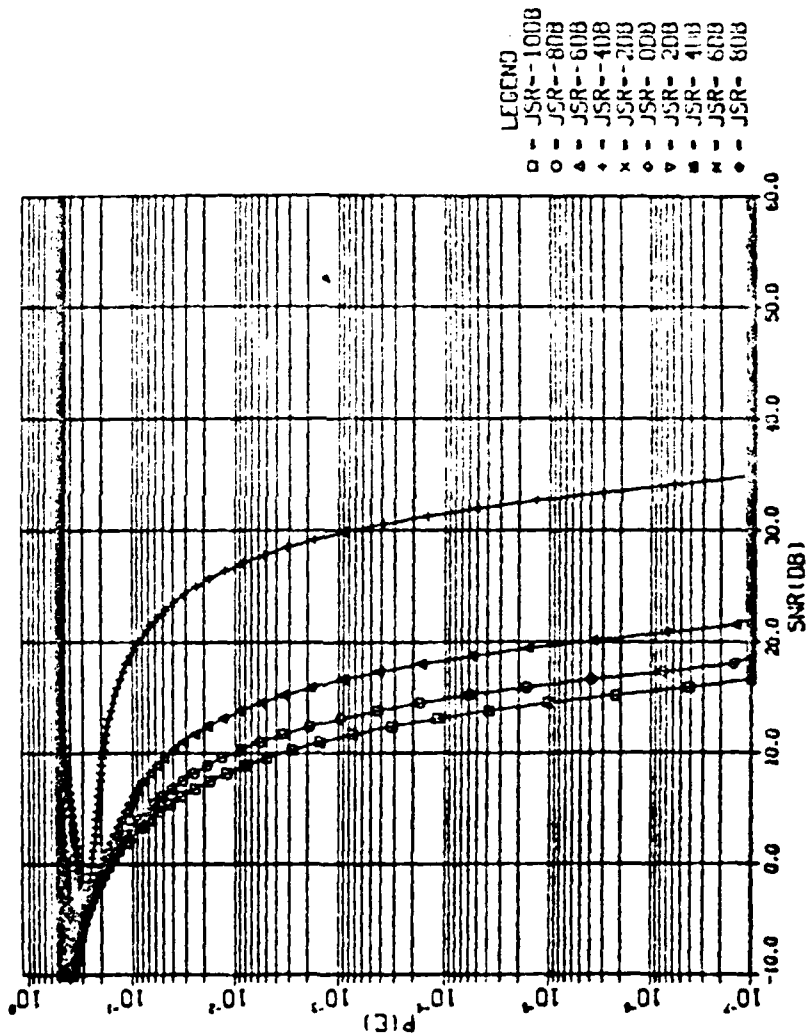

Figure 5.14 Frequency Modulated Jammer for FSK Modulated Signal.

FSK WITH LINEAR FM JAMMING

CASE #2 TWO SWEEPS/CYCLE (K=2.)

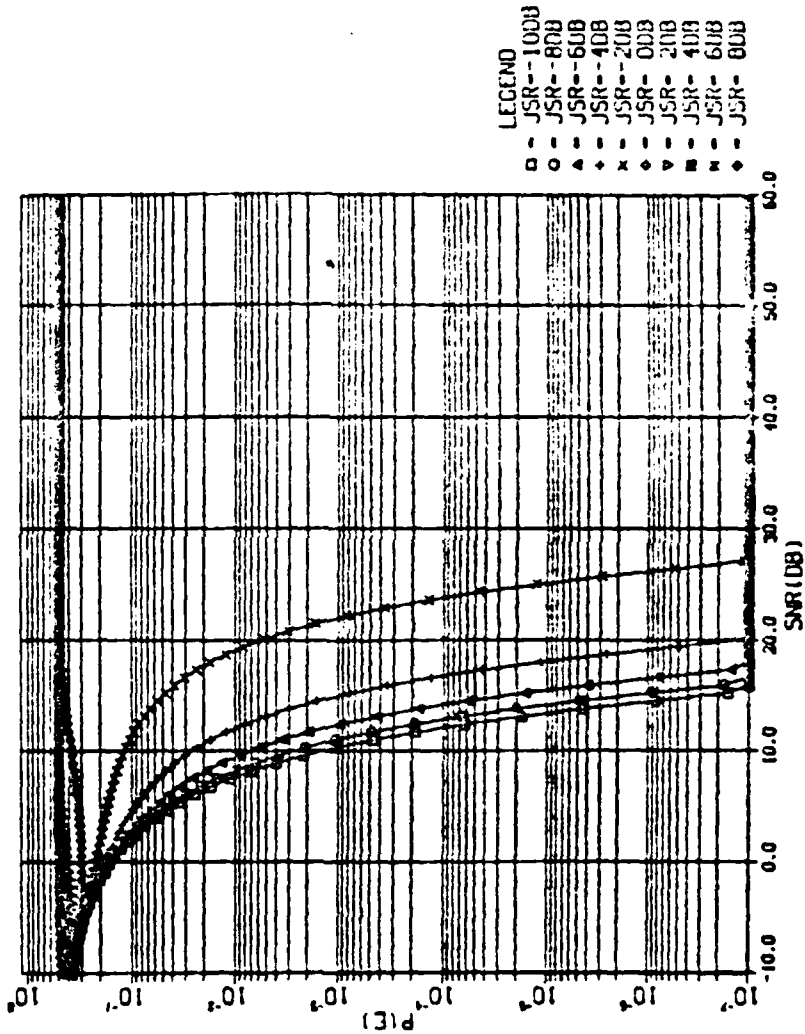

Figure 5.15 Frequency Modulated Jammer for FSK Modulated Signal.

CASE OF NEAR OPTIMUM JAMMING

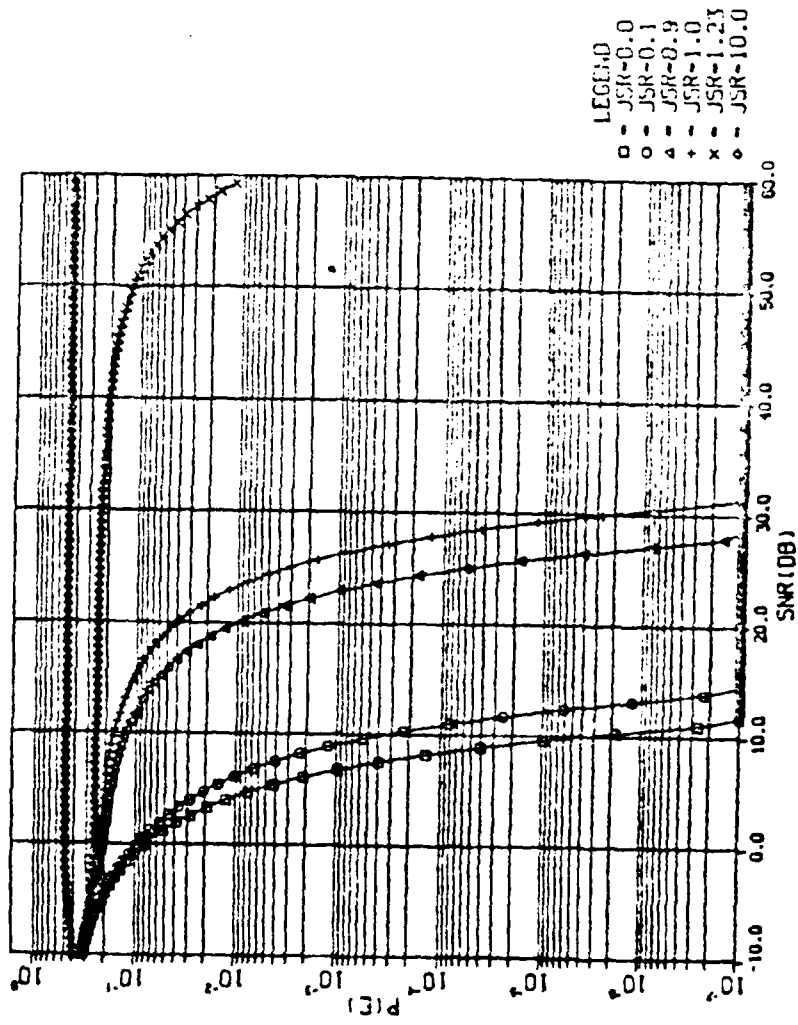

Figure 5.16 Near Optimum Jammer.

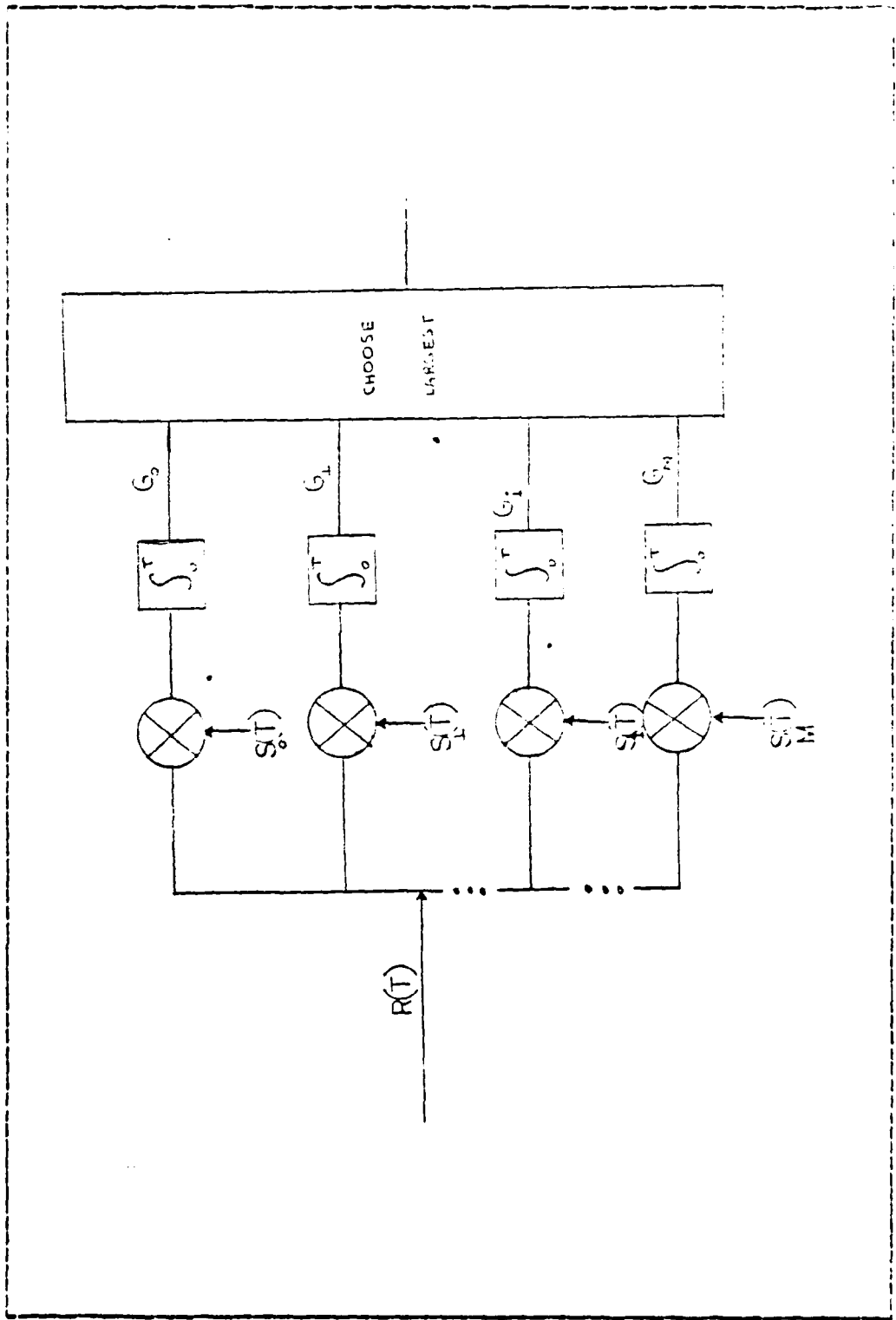

Figure 5.17 M-ary coherent correlator receiver.

MARYFSK W/ DETERMINISTIC JAMMING

M=2

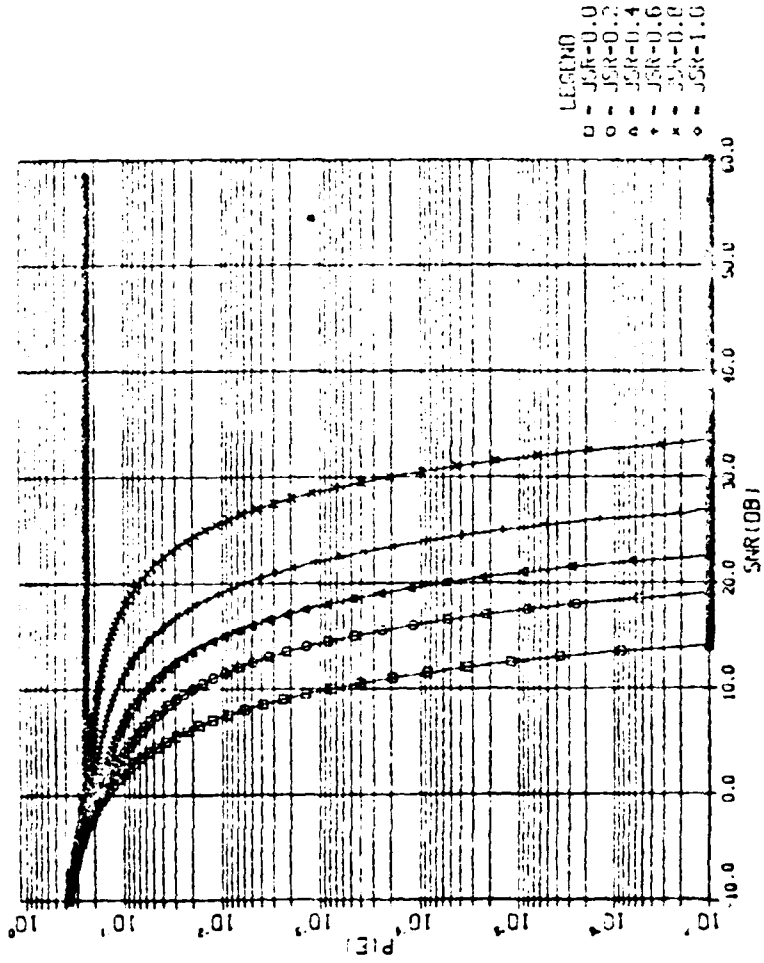

Figure 5.18 M-ary FSK with Single Channel Jam (M=2).

MARYFSK W/ DETERMINISTIC JAMMING
M=10

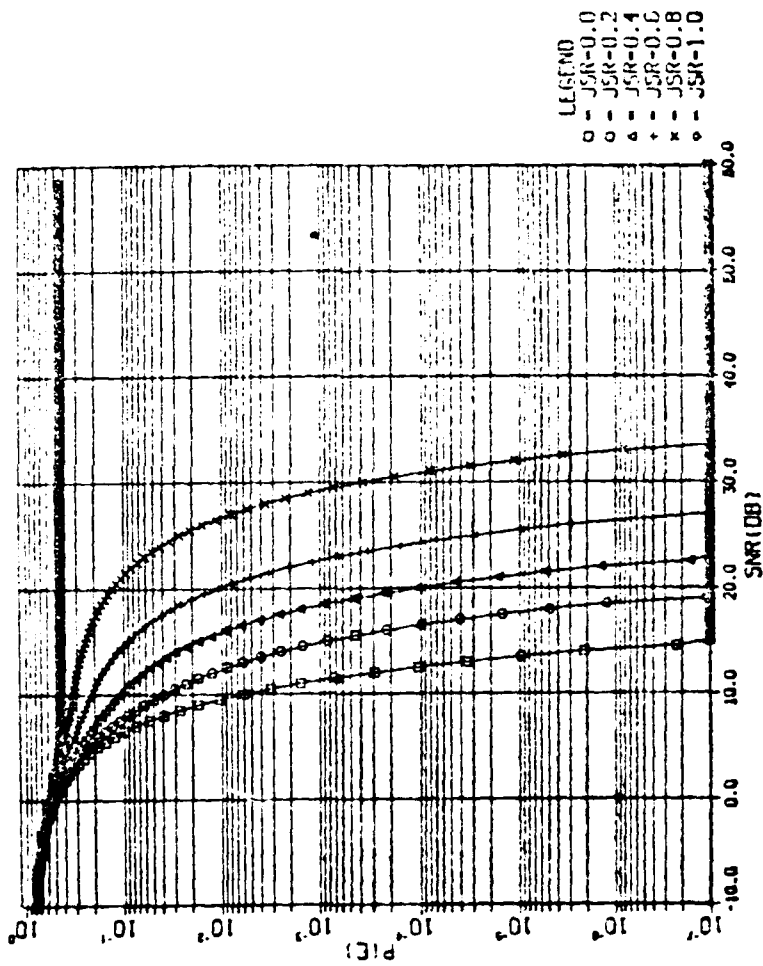

Figure 5.19 M-ary FSK with Single Channel Jam (M=10).

M-ary FSK W/ DETERMINISTIC JAMMING

M=100

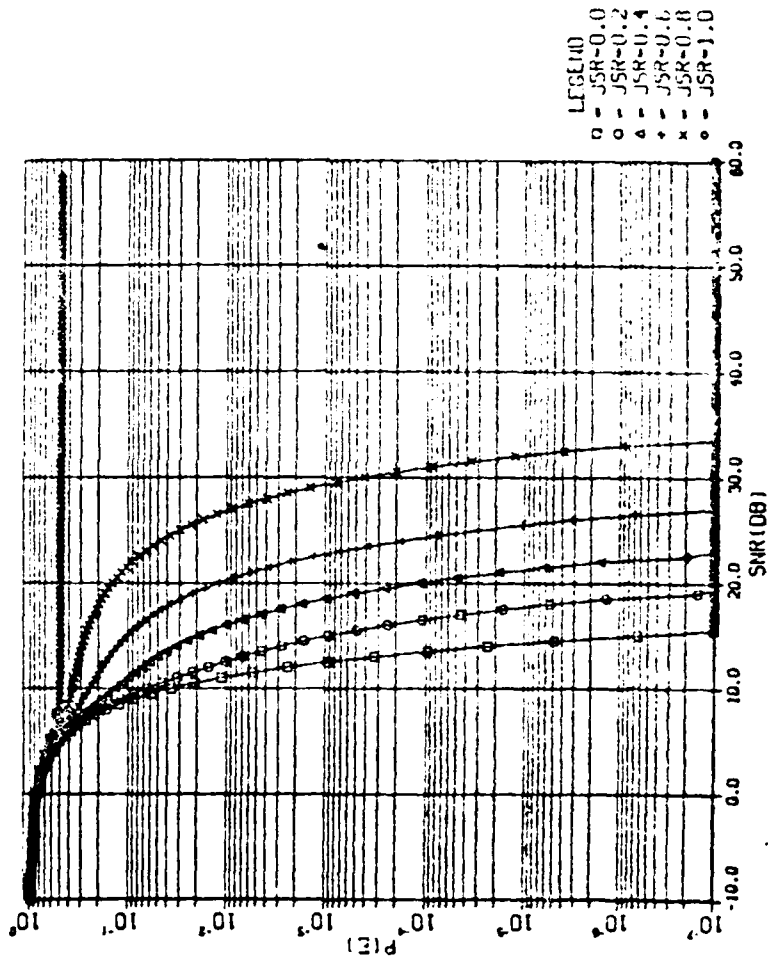

Figure 5.20 M-ary FSK with Single Channel Jam (M=100).

LIST OF REFERENCES

1. Whalen, A. D., Detection of Signals in Noise , Academic Press, 1971.
2. Bukofzer, D., Final Report for Research Contract No. 5156-5160, "Performance of Optimum and Suboptimum Incoherent Digital Communication Receivers in the Presence of Noise and Jamming", February 1964.
3. Ziemer R. E. and W. H. Tranter, Principles of Communications , Houghton Mifflin Company, 1976.
4. Schwartz, M., Information Transmission, Modulation, and Noise , McGraw-Hill Book Company, 1970.
5. Viterbi, A. J., Principles of Coherent Communication , McGraw-Hill Book Company, 1966.

BIBLIOGRAPHY

Helstrom, C.W., Statistical Theory of Signal Detection, 2nd ed. Pergamon Press, New York, 1968.

Schwartz, M., Information Transmission, Modulation, and Noise, 2nd ed. McGraw-Hill, New York, 1970.

Van Trees, H.L., Detection, Estimation, and Modulation Theory, Vols. I-III. Wiley, New York, 1968 (Vol. I), 1971 (Vol. II), 1971 (Vol. III).

Viterbi, A.J., Principles of Coherent Communication, McGraw-Hill, New York, 1966.

Wozencraft, J.M., and I.M. Jacobs, Principles of Communication Engineering, Wiley, New York, 1965.

Ziemer, R.E., and W.H. Trauter, Principles of Communications, Houghton Mifflin, Boston, 1976.

INITIAL DISTRIBUTION LIST

	No. Copies
1. Defense Technical Information Center Cameron Station Alexandria, Virginia 22314	2
2. Library, Code 0142 Naval Postgraduate School Monterey, California 93943	1
3. Prof. D. Bukofzer, Code 628h Naval Postgraduate School Monterey, California 93943	5
4. Prof. S. Jauregui, Code 62Ja Naval Postgraduate School Monterey, California 93943	2
5. LT Paris T. Farwell 1035 Halsey Drive Monterey, California 93940	1

END