

MICROCOPY RESOLUTION TEST CHART  
NATIONAL BUREAU OF STANDARDS-1963-A

AD-A144 575

①

CONNECTICUT COASTAL BASIN  
HAMDEN, CONNECTICUT

**FARM BROOK SITE 2B DAM  
CT 01547**

PHASE I INSPECTION REPORT  
NATIONAL DAM INSPECTION PROGRAM



AUG 21 1984

DEPARTMENT OF THE ARMY  
NEW ENGLAND DIVISION, CORPS OF ENGINEERS  
WALTHAM, MASS. 02154

FILE COPY

SEPTEMBER 1981

UNCLASSIFIED

SECURITY CLASSIFICATION OF THIS PAGE (When Data Entered)

REPORT DOCUMENTATION PAGE		READ INSTRUCTIONS BEFORE COMPLETING FORM
1. REPORT NUMBER CT 01547	2. GOVT ACCESSION NO. A144575	3. RECIPIENT'S CATALOG NUMBER
4. TITLE (and Subtitle) Farm Brook Site 2B Dam  NATIONAL PROGRAM FOR INSPECTION OF NON-FEDERAL DAMS	5. TYPE OF REPORT & PERIOD COVERED INSPECTION REPORT	
	6. PERFORMING ORG. REPORT NUMBER	
7. AUTHOR(s) U.S. ARMY CORPS OF ENGINEERS NEW ENGLAND DIVISION	8. CONTRACT OR GRANT NUMBER(s)	
9. PERFORMING ORGANIZATION NAME AND ADDRESS	10. PROGRAM ELEMENT, PROJECT, TASK AREA & WORK UNIT NUMBERS	
11. CONTROLLING OFFICE NAME AND ADDRESS DEPT. OF THE ARMY, CORPS OF ENGINEERS NEW ENGLAND DIVISION, NEDED 424 TRAPELO ROAD, WALTHAM, MA. 02254	12. REPORT DATE September 1981	
	13. NUMBER OF PAGES 55	
14. MONITORING AGENCY NAME & ADDRESS (if different from Controlling Office)	15. SECURITY CLASS. (of this report)  UNCLASSIFIED	
	15a. DECLASSIFICATION/DOWNGRADING SCHEDULE	
16. DISTRIBUTION STATEMENT (of this Report)  APPROVAL FOR PUBLIC RELEASE: DISTRIBUTION UNLIMITED		
17. DISTRIBUTION STATEMENT (of the abstract entered in Block 20, if different from Report)		
18. SUPPLEMENTARY NOTES Cover program reads: Phase I Inspection Report, National Dam Inspection Program; however, the official title of the program is: National Program for Inspection of Non-Federal Dams; use cover date for date of report.		
19. KEY WORDS (Continue on reverse side if necessary and identify by block number) DAMS, INSPECTION, DAM SAFETY,  Connecticut Coastal Basin Hamden, Connecticut		
20. ABSTRACT (Continue on reverse side if necessary and identify by block number) The Farm Brook Site 2B Dam consists of an earth embankment approximately 1,000 ft. long with a top width of 14 ft. and a maximum height of 28 ft. Based on the visual inspection and review of available plans and reports, Farm Brook Site 2B Dam is judged to be in good condition, with the exception of the seepage observed flowing from the 8" outlet at the west side of the impact basin. It is classified as 'Intermediate' in size with high hazard potential. A test flood equal to the PMF was selected.		



DEPARTMENT OF THE ARMY  
NEW ENGLAND DIVISION, CORPS OF ENGINEERS  
424 TRAPELO ROAD  
WALTHAM, MASSACHUSETTS 02254

REPLY TO  
ATTENTION OF:  
NEDED

SEP 18 1981

Honorable William A. O'Neill  
Governor of the State of Connecticut  
State Capitol  
Hartford, Connecticut 06115

Dear Governor O'Neill:

Inclosed is a copy of the Farm Brook Site 2B Dam (CT-01547) Phase I Inspection Report, prepared under the National Program for Inspection of Non-Federal Dams. This report is based upon a visual inspection, a review of the past performance and a brief hydrological study of the dam. I approve the report and support the findings and recommendations described in Section 7 and ask that you keep me informed of the actions taken to implement them. This follow-up action is vitally important.

Copies of this report have been forwarded to the Department of Environmental Protection. Copies will be available to the public in thirty days.

I wish to thank you and the Department of Environmental Protection for your cooperation in this program.

Sincerely,

C. E. EDGAR, III  
Colonel, Corps of Engineers  
Division Engineer

Incl  
As stated



A-1

FARM BROOK SITE 2B DAM

CT 01547

CONNECTICUT COASTAL BASIN

HAMDEN, CONNECTICUT

PHASE I INSPECTION REPORT

NATIONAL DAM INSPECTION PROGRAM

NATIONAL DAM INSPECTION PROGRAM  
PHASE I INSPECTION REPORT

IDENTIFICATION NO: CT-01547  
NAME OF DAM: Farm Brook Site 2B Dam  
TOWN: Hamden  
COUNTY AND STATE: New Haven County, Connecticut  
STREAM: Farm Brook  
DATE OF INSPECTION: June 2, 1981

Brief Assessment

Being one of two structures impounding water at the Farm Brook Site 2 Reservoir (See Farm Brook Site 2A Dam CT-01546 Report) the Farm Brook Site 2B Dam consists of an earth embankment approximately 1,000 ft. long with a top width of 14 ft. and a maximum height of 28 ft. The low level outlet for the project is the principal spillway which consists of a three-stage reinforced concrete intake riser, a 30-inch reinforced concrete pipe and a 16 ft. long impact basin. In addition to the low-level outlet, there is a 90 ft. wide, grassed trapezoidal channel at the east end of the dam serving as the emergency spillway.

Based on the visual inspection and review of available plans and reports, Farm Brook Site 2B Dam is judged to be in good condition, with the exception of the seepage observed flowing from the 8" outlet at the west side of the impact basin. Since the reservoir level was very low at the time of inspection, any possible embankment seepage at the dam could not be ascertained.

As per the Corps of Engineers' Recommended Guidelines for Safety Inspection of Dams, the Farm Brook Site 2B Dam is classified as 'Intermediate' in size with high hazard potential. A test

flood equal to the probable maximum flood (PMF) was selected in accordance with the Corps of Engineers' Guidelines. The calculated test flood inflow of 6000 cfs results in a routed outflow of 5980 cfs, of which 4130 cfs and 1850 cfs respectively pass over the spillways at site 2A and 2B dams. With the water level at the top of the site 2B Dam, the maximum spillway capacity is 3800 cfs which is 205% of its routed outflow 1850 cfs. The storage capacity of the reservoir at the top of the dam is 1190 ac. ft.

As the dam is a 'high' hazard potential, a breach may result in excessive economic loss and endangerment of more than a few lives. Therefore, an emergency operation plan, including a downstream warning system, should be prepared and implemented.

It is recommended that the owner employ a qualified registered engineer to do the following within one year of receipt of this report:

Determine the origin and significance of the seepage observed from the 8" outlet at the west side of the impact basin.

The recommendations given below and the remedial measures contained in Section 7 should be carried out by the owner within two years of receipt of this report. A qualified registered engineer should be employed by the owner to undertake the following two recommendations.

Evaluate the existing waterway located south of the dam considering the present and future flooding effects on the toe of the embankment and the need to riprap the remaining length of the waterway.

Inspect the dam during the time floodwater is impounded in the reservoir with particular attention to locating possible seepage.

GOODKIND & O'DEA, INC.  
AND  
SINGHAL ASSOCIATES  
(J.V.)

*Ramesh P. Singhal*

Ramesh Singhal, PH.D., P.E.  
(Singhal Associates)

*Lawrence J. Buckley*

Lawrence J. Buckley, P.E.  
(Goodkind & O'Dea, Inc.)

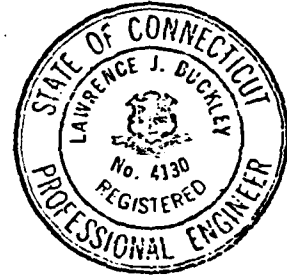
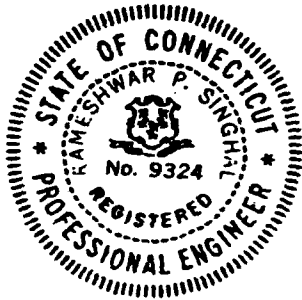

This Phase I Inspection Report on Farm Brook Site 2B Dam (CT-01547) has been reviewed by the undersigned Review Board members. In our opinion, the reported findings, conclusions, and recommendations are consistent with the Recommended Guidelines for Safety Inspection of Dams, and with good engineering judgement and practice, and is hereby submitted for approval.

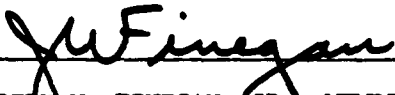
  
JOSEPH W. FINEGAN, JR. MEMBER  
Water Control Branch  
Engineering Division

  
ARAMAST MAHTESIAN, MEMBER  
Geotechnical Engineering Branch  
Engineering Division

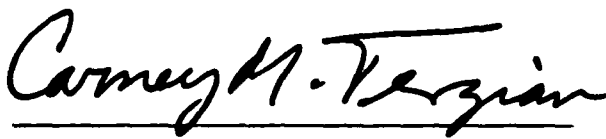
  
CARNEY M. TERZIAN, CHAIRMAN  
Design Branch  
Engineering Division

APPROVAL RECOMMENDED:

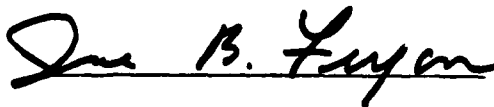
  
JOE B. FRYAR  
Chief, Engineering Division

## PREFACE

This report is prepared under guidance contained in the Recommended Guidelines for Safety Inspection of Dams, for Phase I Investigations. Copies of these guidelines may be obtained from the Office of Chief of Engineers, Washington, D.C. 20314. The purpose of a Phase I Investigation is to identify expeditiously those dams which may pose hazards to human life or property. The assessment of the general condition of the dam is based upon available data and visual inspections. Detailed investigation, and analyses involving topographic mapping, subsurface investigations, testing, and detailed computational evaluations are beyond the scope of a Phase I investigation: however, the investigation is intended to identify any need for such studies.

In reviewing this report, it should be realized that the reported condition of the dam is based on observations of field conditions at the time of inspection along with data available to the inspection team. In cases where the reservoir was lowered or drained prior to inspection, such action, while improving the stability and safety of the dam, removes the normal load on the structure and may obscure certain conditions which might otherwise be detectable if inspected under the normal operating environment of the structure.

It is important to note that the condition of a dam depends on numerous and constantly changing internal and external conditions, and is evolutionary in nature. It would be incorrect to assume that the

present condition of the dam will continue to represent the condition of the dam at some point in the future. Only through continued care and inspection can there be any chance that unsafe conditions be detected.

Phase I inspections are not intended to provide detailed hydrologic and hydraulic analyses. In accordance with the established Guidelines, the Spillway Test flood is based on the estimated "Probable Maximum Flood" for the region (greatest reasonably possible storm runoff), or fractions thereof. Because of the magnitude and rarity of such a storm event, a finding that a spillway will not pass the test flood should not be interpreted as necessarily posing a highly inadequate condition. The test flood provides a measure of relative spillway capacity and serves as an aide in determining the need for more detailed hydrologic and hydraulic studies, considering the size of the dam, its general condition and the downstream damage potential.

The Phase I Investigation does not include an assessment of the need for fences, gates, no-trespassing signs, repairs to existing fences and railings and other items which may be needed to minimize trespass and provide greater security for the facility and safety to the public. An evaluation of the project for compliance with OSHA rules and regulations is also excluded.

## TABLE OF CONTENTS

<u>SECTION</u>	<u>PAGE NO.</u>
LETTER OF TRANSMITTAL	
BRIEF ASSESSMENT	
REVIEW BOARD PAGE	
PREFACE	i
TABLE OF CONTENTS	iii
OVERVIEW PHOTO	Sheet 1
LOCATION PLAN	Sheet 2

### REPORT

1. PROJECT INFORMATION	
1.1 <u>General</u>	1-1
a. Authority	
b. Purpose of Inspection	
1.2 <u>Description of Project</u>	1-2
a. Location	
b. Description of Dam & Appurtenances	
c. Size Classification	
d. Hazard Classification	
e. Ownership	
f. Operator	
g. Purpose of Dam	
h. Design & Construction History	
i. Normal Operational Procedure	
1.3 <u>Pertinent Data</u>	1-6
a. Drainage Area	
b. Discharge at Damsite	
c. Elevation	
d. Reservoir Length	
e. Storage	
f. Reservoir Surface	
g. Dam	
h. Diversion & Regulating Tunnel	
i. Spillway	
j. Regulating Outlets	

<u>SECTION</u>	<u>PAGE NO.</u>
2. ENGINEERING DATA	
2.1 <u>Design Data</u>	2-1
2.2 <u>Construction Data</u>	2-1
2.3 <u>Operation Data</u>	2-1
2.4 <u>Evaluation of Data</u>	2-2
a. Availability	
b. Adequacy	
c. Validity	
3. VISUAL INSPECTION	
3.1 <u>Findings</u>	3-1
a. General	
b. Dam	
c. Appurtenant Structures	
d. Reservoir Area	
e. Downstream Channel	
3.2 <u>Evaluation</u>	3-5
4. OPERATIONAL & MAINTENANCE PROCEDURES	
4.1 <u>Operational Procedures</u>	4-1
a. General	
b. Description of any Warning System in Effect	
4.2 <u>Maintenance Procedures</u>	4-1
a. General	
b. Operating Facilities	
4.3 <u>Evaluation</u>	4-2
5. EVALUATION OF HYDRAULIC/HYDROLOGIC FEATURES	
5.1 <u>General</u>	5-1
5.2 <u>Design Data</u>	5-1
5.3 <u>Experience Data</u>	5-2
5.4 <u>Test Flood Analysis</u>	5-2
5.5 <u>Dam Failure Analysis</u>	5-3

SECTION

PAGE NO.

6.	EVALUATION OF STRUCTURAL STABILITY	
6.1	<u>Visual Observation</u>	6-1
6.2	<u>Design &amp; Construction Data</u>	6-1
6.3	<u>Post-Construction Changes</u>	6-1
6.4	<u>Seismic Stability</u>	6-2
7.	<u>ASSESSMENT, RECOMMENDATIONS &amp; REMEDIAL MEASURES</u>	
7.1	<u>Project Assessment</u>	7-1
	a. Condition	
	b. Adequacy of Information	
	c. Urgency	
7.2	<u>Recommendation</u>	7-1
7.3	<u>Remedial Measures</u>	7-2
	a. Operation & Maintenance Procedures	
7.4	<u>Alternatives</u>	7-3

APPENDICES

<u>SECTION</u>	<u>PAGE NO.</u>
APPENDIX A: INSPECTION CHECKLISTS	A-1 to A-5
APPENDIX B: ENGINEERING DATA	
Engineering Data Checklist	B-1
Engineering Data from Design Report	B-2 to B-9
Bibliography	B-10
General Plan	Sheet B-1
Typical Dam Section & Profile of Principal Spillway	Sheet B-2
Typical Section & Profile of Emergency Spillway	Sheet B-3
Typical Drill Holes	Sheet B-4
APPENDIX C: DETAIL PHOTOGRAPHS	
Photo Location Plan	Sheet C-1
Photographs	C-1 to C-4
APPENDIX D: HYDROLOGIC AND HYDRAULIC COMPUTATIONS	
Drainage Area Map	Sheet D-1
Computations	D-1 to D-17
APPENDIX E: INFORMATION AS CONTAINED IN THE NATIONAL INVENTORY OF DAMS	

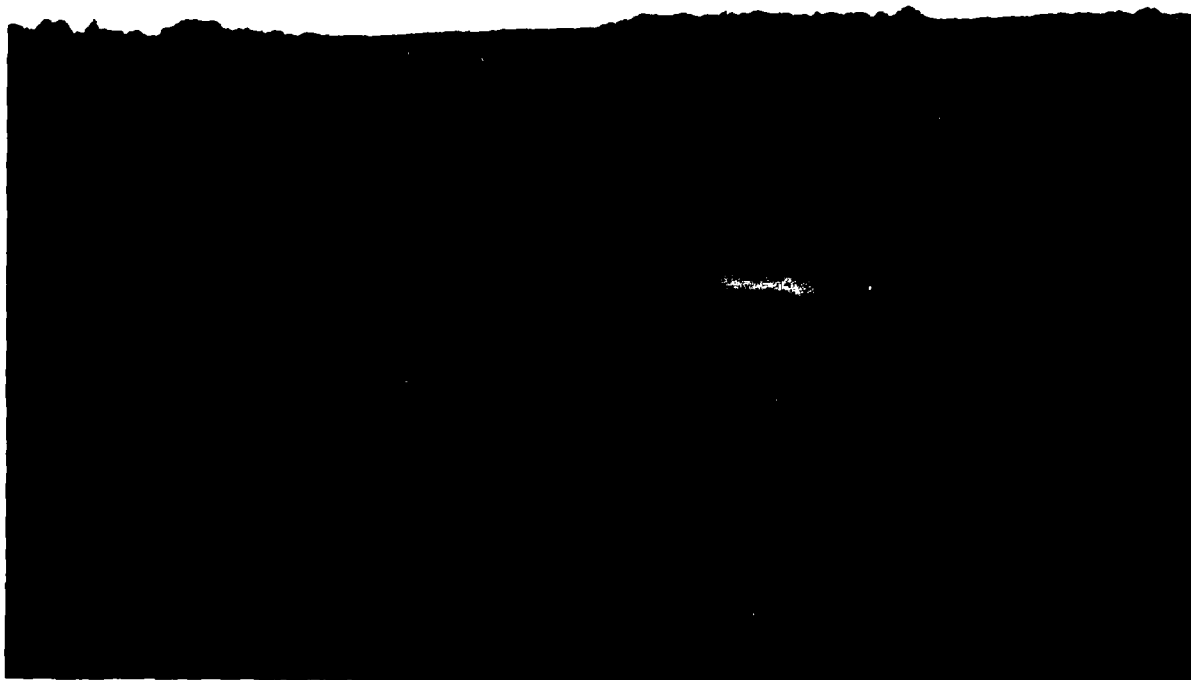

NOTE:

OVERVIEW PHOTO TAKEN JUNE 2, 1981.

GOODKIND & O'DEA INC- SINGHAL ASSOCIATES/LV ENGINEERS	U.S. ARMY ENGINEER DIV. NEW ENGLAND CORPS OF ENGINEERS WALTHAM, MASS.			
NATIONAL PROGRAM OF INSPECTION OF NON-FED. DAMS OVERVIEW PHOTO OF DAM FARM BROOK SITE 2B DAM HAMDEN, CONNECTICUT				
DRAWN BY E.T.K.	CHECKED BY W.J.W.	APPROVED BY L.J.B.	SCALE: NONE DATE: SEPT, 1981	SHEET 1

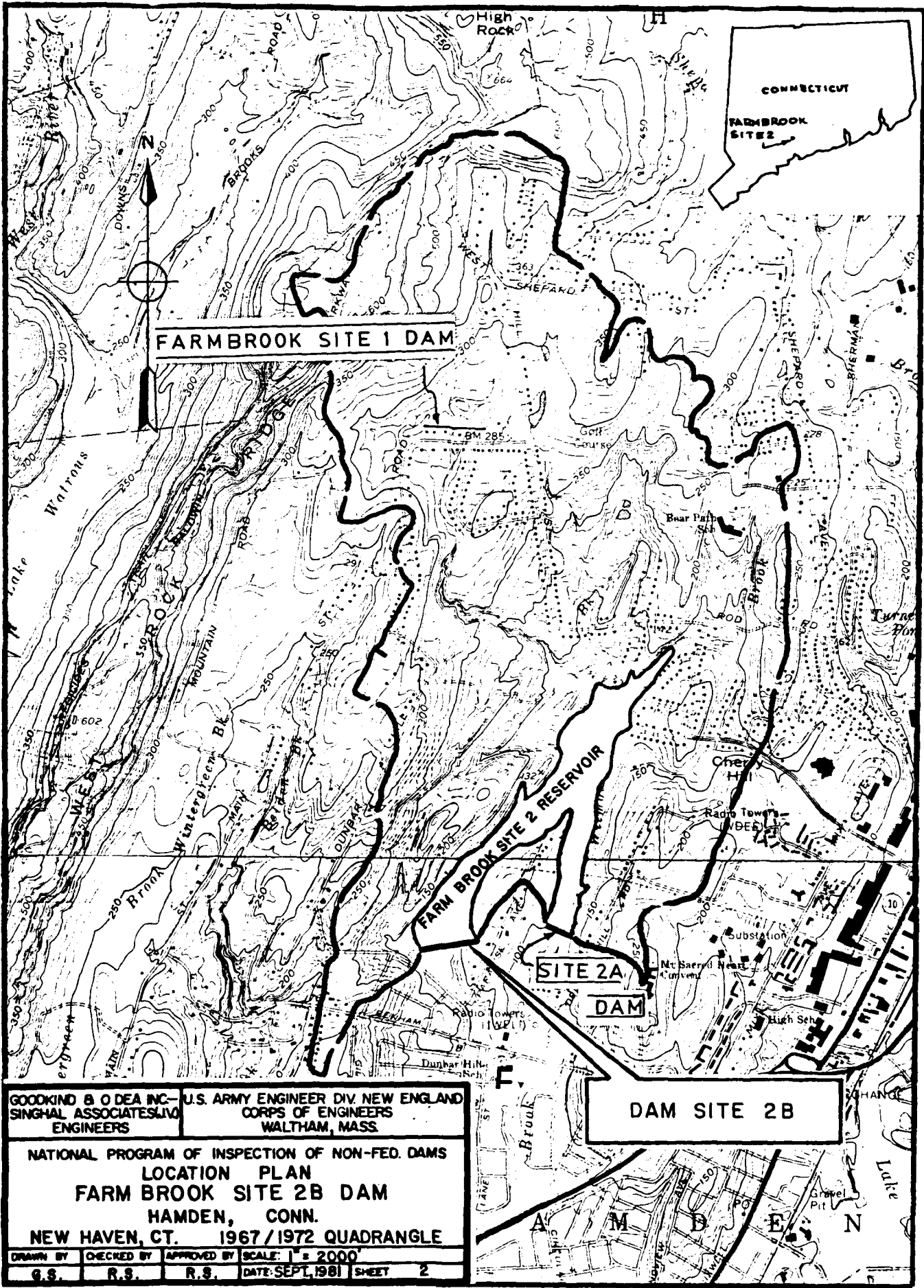

GOODKIND & O'DEA INC.-  
SINGHAL ASSOCIATES/LIV  
ENGINEERS

U.S. ARMY ENGINEER DIV. NEW ENGLAND  
CORPS OF ENGINEERS  
WALTHAM, MASS.

NATIONAL PROGRAM OF INSPECTION OF NON-FED. DAMS  
LOCATION PLAN  
FARM BROOK SITE 2B DAM  
HAMDEN, CONN.  
NEW HAVEN, CT. 1967/1972 QUADRANGLE

DRAWN BY	CHECKED BY	APPROVED BY	SCALE: 1" = 2000'
G.S.	R.S.	R.S.	DATE: SEPT, 1981 SHEET 2

NATIONAL DAM INSPECTION PROGRAM  
PHASE I INSPECTION REPORT

PROJECT INFORMATION  
Section 1

1.1 GENERAL

a. Authority

Public Law 92-367, August 8, 1972, authorized the Secretary of the Army, through the Corps of Engineers, to initiate a National Program of Dam Inspection throughout the United States, the New England Division of the Corps of Engineers has been assigned the responsibility of supervising the inspection of dams within the New England Region. Goodkind & O'Dea Inc., Hamden, Conn. and Singhal Associates, Orange, Connecticut (Joint Venture) have been retained by the New England Division to inspect and report on selected dams in the State of Connecticut. Authorization and notice to proceed were issued to Goodkind & O'Dea, Inc. and Singhal Associates (J.V.) under a letter of June 22, 1981 from Colonel William E. Hodgson, Jr., Corps of Engineers. Contract No. DACW 33-81-C-0022 dated December 9, 1980 has been assigned by the Corps of Engineers for this work.

b. Purpose of Inspection

The purposes of the program are to:

1. Perform technical inspection and evaluation of non-federal dams to identify conditions requiring correction in a timely manner by non-federal interest.
2. Encourage and prepare the States to quickly initiate effective dam inspection programs for non-federal dams.

3. To update, verify and complete National Inventory  
of Dams

1.2 Description of Project

a. Location

The Farm Brook Site 2B dam is situated on the Farm Brook in the watershed of the West River. The confluence with the West River is approximately 3.5 miles downstream. Location of the project is 0.3 miles northwest of WELI radio station and 1000 ft. north of the intersection of Paradise Ave. and Cooper Lane. The geographic location of the site may be found on the New Haven Quadrangle Map having coordinates of Latitude N 41<sup>o</sup>-22.2' and longitude W 72<sup>o</sup>-56.4'.

b. Description of Dam and Appurtenant Structures

Farm Brook Site 2B Dam is one of two dams which impound floodwaters for the Farm Brook Site 2 Reservoir. Consisting of a grass covered earth embankment, the structure is approximately 1000 ft. long with a crest width of 14 ft. As shown on the typical dam section in Appendix B, the upstream slope is 3 horizontal to 1 vertical, whereas the downstream slope is 2.5 horizontal to 1 vertical. The crest elevation of the embankment is 107.7' (all elevations in report refer to NGVD) with a maximum height of 28 ft. Situated under the downstream embankment is a 3 ft. wide trench drain of varying depth, containing an 8" perforated pipe. The underdrain system outlets through three pipes of which two are located at the impact basin. (See general plan in Appendix B), In addition to the trench drain, there is also a 12 ft. wide cutoff trench, approximately 4 ft. deep centered under the embankment crest.

Located at the toe of the downstream slope of the dam is a waterway with a channel bottom varying from 3 to 6 ft. As indicated on the general plan in Appendix B, the waterway outlets into the downstream brook with two-thirds of the channel lined with riprap.

Serving as the low-level outlet, the reinforced concrete principal spillway consists of a three stage intake riser discharging through a 30 inch pipe under the dam embankment. Approximately 144 ft. long, the pipe outlets into a 16 ft. long impact basin before flowing into the downstream channel. This channel is riprapped for a distance of 67 ft. of which the first 23 ft. is grouted (See profile along centerline of principal spillway in Appendix B).

The intake riser consists of a low and high level orifice and two riser crest weirs, which have invert elevations of 82.5', 85.5' and 96.5' respectively. Normally in the closed position, a sliding gate is located at the 15" x 15" low level orifice. A steel plate, 2' wide by 1' high has been bolted across the lower half of the 2' x 2' high level orifice; thereby decreasing its effective size to 2' x 1'. Trash racks are located at both the high level orifice and the riser crest weirs. The upstream embankment slope in the vicinity of the intake riser is protected with grouted riprap up to an elevation of 87.0'.

Immediately east of the dam embankment is the emergency spillway which is a grassed trapezoidal channel, 90 ft. wide at its control section. Approximately 5.7 ft. below the top of dam, this level control section has a crest elevation of 102.0'.

The approach channel is at a grade of +2.0%, whereas the discharge channel has a grade of -2.5%. East of the spillway channel, the cut slope varies from 2½ to 3 horizontal to 1 vertical with a portion riprapped in the area of the access road (See general plan in Appendix B). Situated along the west side of the discharge channel is a small dike approximately 230 ft. in length with a top width of 10 ft. As indicated on Sheet B-3 in Appendix B, the crest elevation varies from 107.7' at the level section to 101.8' at the south end. The earthen embankment has slopes of 2 1/2 horizontal to 1 vertical with its east slope riprapped.

c. Size Classification: 'Intermediate'

According to the Corps of Engineers' Recommended Guidelines for Safety Inspection of Dams, a dam is classified 'Intermediate' if either its height is between 40 and 100 ft. or the storage volume is between 1000 and 50,000 ac. ft. or both. The Farm Brook Site 2B Dam has a maximum height of 28 ft. only, but the maximum storage is 1,190 ac. ft. As such it is classified as 'Intermediate' in size.

d. Hazard Classification: 'High'

Based on the Corps of Engineers' Recommended Guidelines for Safety Inspection of Dams the hazard classification for Farm Brook Site 2B Dam is 'High'. A dam failure analysis indicates that a breach of the dam would result in a downstream flood flow of approximately 94,000 cfs causing a 26 ft. high wave of water to travel down the Farm Brook and its overbanks. Continuation of the valley flood routing through the brook shows that at the second cross-section 950 ft. down from the dam at the intersection of Cooper Lane and Paradise Avenue, the flood flow and wave heights are 87,000 cfs and 19 ft. respectively.

The depths of flow in the brook in the vicinity of 5 houses located on Cooper Lane on either side of its intersection with Megin Drive are 3 ft. under the pre-failure condition and 19 ft. under post-failure condition. None of these houses are subject to flooding under the test flood condition. Under dam failure condition, they will be flooded to depths of 1 to 5 ft. above their first flood elevation.

The dam failure would result in flooding of additional houses and streets. There is potential for 'excessive economic loss' and possible loss of 'more than a few lives'.

e. Ownership

The Farm Brook Reservoir and dams 2A and 2B are owned by:

The State of Connecticut  
Department of Environmental Protection  
State Office Building  
165 Capitol Avenue  
Hartford, Connecticut. 06115  
Telephone: (203) 566-7244/7245

f. Operator:

Mr. Victor Galgowski  
Superintendent, Dam Maintenance  
D. E. P. (Water Resources Unit)  
165 Capitol Avenue  
Hartford, Conn. 06115  
Telephone: (203) 566-7244/7245

g. Purpose of Dam

The purpose of the dam is primarily for flood control.

h. Design and Construction History

The dam and appurtenant structures were designed in the year 1971 by the U. S. Department of Agriculture, Soil Conservation Service. Dam construction was completed in the year 1977.

	<u>Principal Spillway (cfs)</u>	<u>Emergency Spillway (cfs)</u>	<u>Total (cfs)</u>
4. Ungated spillway capacity at test flood elevation: Elevation	120	+ 1730 =	1850 105.4
5. Gated spillway capacity at normal pool elevation:			N/A
6. Gated spillway capacity at test flood elevation			N/A
7. Total spillway capacity at test flood elevation: Elevation:	120	+ 1730 =	1850 105.4
8. Total project discharge at top of dam: Elevation:	130	+ 3670	3800 107.7
9. Total project discharge at test flood elevation: Elevation:	120	+ 1730 =	1850 105.4
<b>c. <u>Elevation</u> (NGVD):</b>			
1. Streambed at toe of dam:			80.0
2. Bottom of cutoff:			77.0
3. Maximum tailwater:			N/A
4. Normal Pool:			85.5
5. Full flood control pool:			102.0
6. Spillway crest:			102.0 (Emergency) 96.5 (Principal - high level inlet weir)
7. Design surcharge (original design):			105.7
8. Top of Dam:			107.7
9. Test flood surcharge			105.4
<b>d. <u>Reservoir Length in Feet</u></b>			
1. Normal pool:			1100
2. Flood control pool:			6000
3. Spillway crest pool			
Emergency spillway:			6000
Principal spillway (Riser crest weirs):			5700

4.	Top of Dam:	6400
5.	Test flood pool:	6300
e.	<u>Storage (Acre-Feet)</u>	
1.	Normal pool:	18
2.	Flood control pool:	720
3.	Spillway crest pool	
	Emergency spillway:	720
	Principal spillway	
	(Riser crest weirs):	348
4.	Top of dam:	1,190
5.	Test flood pool:	1,000
f.	<u>Reservoir Surface - Acres</u>	
1.	Normal pool:	8
2.	Flood control pool:	80
3.	Spillway crest	
	Emergency spillway:	80
	Principal spillway	
	(Riser crest weirs)	56
4.	Top of Dam:	120
5.	Test flood pool:	106
g.	<u>Dam</u>	
1.	Type:	Earth embankment
2.	Length:	1,000 ft.
3.	Height:	28 ft.
4.	Top Width:	14.0 ft.
5.	Side slopes:	3 hor. to 1 vert. (upstream) 2½ hor. to 1 vert. (downstream)
6.	Zoning:	None. Entire section made of compacted fill.
7.	Impervious core:	N/A
8.	Cutoff:	12 ft. wide, 4 ft. deep cutoff trench
9.	Grout curtain:	N/A
10.	Other:	N/A

h. Diversion and Regulating Tunnel N/A

i. Spillway

	<u>Principal Spillway</u>	<u>Emergency Spillway</u>
1. Type:	Drop inlet structure consisting of a three stage reinforced concrete intake riser with a 30" reinforced concrete pipe.	Grassed trapezoidal channel
2. Length of crest:	15 ft. (high level inlet weir)	90 ft. at the control section.
3. Crest Elevation:		
w/ flashboards:	N/A	N/A
w/o flashboards:	96.5 (high level inlet weir)	102.0
4. Gates	N/A	N/A
5. Upstream Channel:	Farm Brook (natural channel)	N/A
6. Downstream Channel:	16 ft. long impact basin leading to natural channel with 67' of riprap	N/A
7. General:	N/A	N/A
j. <u>Regulating Outlets:</u>		
1. Invert		82.5
2. Size		15" x 15"
3. Description		Low level outlet which normally remains closed
4. Control Mechanism		Stainless steel sliding gate located at inner wall of intake riser with gate stem extending to top of structure.
5. Other:		N/A

## ENGINEERING DATA

### Section 2

#### 2.1 Design Data

In 1971, the United States Department of Agriculture, Soil Conservation Service prepared a design report and design plans for Farm Brook Site 2, which consists of two dams, Site 2A and Site 2B. Entitled "Farmbrook Site No. 2", the design report includes hydrologic and hydraulic data and computations, geology report, soil testing report and dam stability analysis. Several pages of the report and logs of two typical drill holes pertaining to Site 2B Dam have been copied and are given in Appendix B.

#### 2.2 Construction Data

The U.S. Soil Conservation Service completed the "As-Built" drawings for Farm Brook Site 2B Dam in August, 1977. These drawings, which are part of the overall Site 2 Watershed Project, have been reviewed and found to show good agreement with the visual inspection. Certain details have been copied from the drawings and are included in Appendix B.

#### 2.3 Operational Data

Normally, a small pool with a water elevation in the proximity of the high orifice invert exists behind the dam embankment. Water level readings are not taken of this normal pool, nor during flood impoundments. Although there are no formal operation records, a log book of the dam is kept by the State of Connecticut, Department of Environmental Protection. According to the owner, the reservoir level has never risen to the emergency spillway

crest. There is also a general Operation and Maintenance Handbook which was prepared by the U.S. Soil Conservation Service for this dam and similar projects.

#### 2.4 Evaluation

##### a. Availability

The U.S. Soil Conservation Service, who designed and constructed the dam and the State of Connecticut Department of Environmental Protection, who are the owners, provided the available existing data. Location of the available data is included in Appendix B.

##### b. Adequacy

When coupled with the visual inspection, the engineering data available was generally adequate to perform an assessment of the dam.

##### c. Validity

A comparison of the record data and visual observations reveals no significant discrepancies in the record data.

VISUAL INSPECTION  
Section 3

3.1 Findings

a. General

Engineers from Goodkind & O'Dea Inc. and Singhal Associates performed a formal field inspection of Farm Brook Site 2B Dam on June 2, 1980. Included in Appendix A, are detailed checklists which aided in the inspection of the dam and spillways. In addition, photographs of these dam features and the problem areas were taken and are given in Appendix C with the photo location plan.

The project is in good condition with several areas requiring minor maintenance and/or monitoring. At the time of the inspection, the reservoir pool elevation was 85.3', which was two-tenths of a foot below the original high orifice invert elevation.

b. Dam

Farm Brook Site 2B Dam is an earthfill embankment with a foundation drain trench underlying the downstream slope. The vertical and horizontal alignment of the embankment appeared good with no indication of movement (see Photos 1, 2 & 3). Moderate rutting was observed along the crest of the dam as shown in Photo 2. In addition to these vehicular ruts, several areas of exposed earth with signs of minor erosion were noted on the crest. As indicated on the general plan in Appendix B, a narrow footpath was located on the downstream dam embankment. This trail was lacking vegetative cover and appeared to be slightly eroded. The embankment crest and slopes were covered with a stable growth of vetch with the exception of the

areas previously noted.

Inspection of the downstream embankment slope and toe did not reveal any areas of seepage or sloughing. However, since the upstream pool elevation was only 3.5 feet higher than the downstream water level, a conclusive determination of the seepage conditions could not be completed. In addition, only one-half of the dam embankment was retaining water as shown in the Overview Photo.

The foundation drain trench outlets through three 8" pipes as given on the general plan in Appendix B. One pipe, which is approximately 100 feet west of the footpath, was covered and could not be located and therefore was not inspected. Outletting into the concrete impact basin, the two remaining pipes were fully submerged at the time of the inspection. An appreciable amount of seepage was observed to be flowing from the west outlet into the concrete structure. Seepage flow from this outlet was clear and did not appear to be carrying any soil particles. The eastern outlet pipe at the impact basin was clean with no indication of seepage.

Varying from 20 to 40 ft. south of the dam embankment is an excavated waterway which outlets into a downstream channel (see Photo 3). As shown on the general plan in Appendix B, two sections of the waterway are riprapped which appeared stable and are overgrown with weeds. The unlined channel section also appeared stable, with evidence of minor sediment accumulation.

c. Appurtenant Structures

Principal Spillway

The normal reservoir inflow and the impounded

stormwater runoff passes under the dam embankment through the principal spillway. This reinforced concrete structure consists of a three stage intake riser, 30 inch pipe and impact basin. As shown in Photos 4 and 5, the intake riser was in good condition with no concrete cracking or spalling. Steel trash racks at the crest riser and high orifice were well painted and appeared to be structurally sound. Debris, such as tree branches and a small plywood board had accumulated at the high orifice level. Approximately 1' X 2', the plywood board was caught between the trash rack and concrete riser and could possibly obstruct flow to the orifice during high water conditions. The slide gate at the low orifice, which was not operated, was closed and fully submerged, preventing its inspection. Directly behind the intake riser, there is a grouted riprap area which is stable and in good condition (see Photo 4).

As shown in Photos 6 and 7, the reinforced concrete impact basin is in good condition. There was no visible cracking or spalling with the exception of the broken concrete at the base of two fence posts. The west section of the chain linked fence is tilted resulting from the deteriorated concrete condition. Immediately downstream of the impact basin is a riprapped area of which the first 23 feet is grouted and in good condition. The 44 ft. non-grouted riprapped section was also stable, but overgrown with weeds.

#### Emergency Spillway

Abutting the east end of the dam is the emergency spillway which generally was in good condition. The east cut slope and spillway floor were covered with a stable growth of grass

as shown in Photo 8. Riprapped areas along this cut slope and the rock lined diversion, north of the spillway appeared stable with no signs of failure. Groundwater seepage under the spillway approach channel is controlled by a drain trench as indicated on the general plan in Appendix B. The drain trench outlets through a 10" corrugated metal pipe onto a riprapped area. With animal guards in place, the pipe was dry and clean with the riprapped area remaining stable.

Along the west side of the spillway is an earthfill dike which is protected from scouring by a stable riprapped slope. Exposed earth was observed on the grass covered crest and west embankment slope of the dike. Minor slope erosion associated with the bare earthen areas was noted at the north end of the dike as shown in Photo 8.

d. Reservoir Area

The reservoir area for Farm Brook Site 2B Dam primarily consists of open grasslands and wooded areas (see Photo 4). Since the slide gate at the low flow orifice is normally closed, a small pool area exists behind the reservoir area, which serves as a wildlife preserve. Several residential homes border the reservoir which is also part of the Farm Brook Site 2 Watershed Project.

e. Downstream Channel

The channel downstream from the impact basin is generally open with no build-up of brush or debris. Minor weed growth was noted in the channel and along its slopes as shown in Photo 7. At the confluence of the downstream waterway, sediment has accumulated, which is partially obstructing

the channel flow.

### 3.2 Evaluation

As assessed by the visual inspection, the condition of the dam and appurtenant structures was good with no observed stability problems. The rutted and bare earthen areas along the crest and/or slopes of the dam and spillway dike embankment were the primary problems noted. Continued deterioration at these areas will have an adverse effect on the structural stability of the project.

Observations revealed seepage flow from the 8 inch outlet at the concrete impact basin. Such a problem could be the result of infiltration through and/or under the dam embankment, which could possibly lead to slope sloughing and structural instability.

At the time of the inspection, the upstream water level was only three and one-half feet above the downstream level. Also, only one-half of the dam embankment was retaining water; therefore, a conclusive determination of the seepage conditions that may exist under high water conditions, could not be completed.

## OPERATIONAL AND MAINTENANCE PROCEDURES

### Section 4

#### 4.1 Operational Procedures

##### a. General

Operational procedures for Farm Brook Site 2B Dam generally consist of dam surveillance during periods of heavy stormwater runoff. Inspections of the dam and its features are completed at these times, by a representative of the State of Connecticut, Department of Environmental Protection. Brush and debris are kept free from the intake risers' trash racks to prevent unnecessary water build-up. Although reservoir pool levels are not taken, informal records of the project are registered in a log book.

The steel slide gate at the low flow orifice of the intake riser is not operated on a regular basis and normally remains in the closed position.

##### b. Description of Warning Systems in Effect

There are no warning systems in effect.

#### 4.2 Maintenance Procedures

##### a. General

Maintenance of the dam and appurtenant structures is the responsibility of the State of Connecticut, Department of Environmental Protection. The dam embankment and emergency spillway are mowed annually by the State. In addition, the upstream and downstream channel are cleared of brush and debris, as necessary.

Inspection of Farm Brook Site 2B Dam occurs on an annual basis and is undertaken by representatives from the State

of Connecticut, Department of Environmental Protection and the U.S. Soil Conservation Service. The general condition of the project is assessed and recommendations for necessary repairs and/or maintenance work are given.

b. Operating Facilities

Construction, operation and structural repair of the flood control works is the responsibility of the State of Connecticut, Department of Environmental Protection.

4.3 Evaluation

Generally, the operational and maintenance procedures are satisfactory, but some areas do require improvement. The U.S. Soil Conservation Service prepared a general Operation and Maintenance Handbook for this dam and similar projects. Although the handbook is adequate, additional procedures such as recording maximum pool levels during flood and developing a downstream emergency warning system should be undertaken by the State of Connecticut Department of Environmental Protection. The State should also institute a comprehensive program of inspection to be undertaken on an annual basis by a registered professional engineer qualified in dam inspection.

EVALUATION OF HYDRAULIC/HYDROLOGIC FEATURES  
SECTION 5

5.1 General

Farm Brook Reservoir has a contributory drainage area of 2.63 sq. mi. which is moderately sloping to rolling terrain with average slope of 4.6%. Part of this area is developed with several town roads and residential homes.

Spillways at Farm Brook Sites 2A and 2B dams both act together to pass the floodwaters from the reservoir to the downstream areas.

Under Farm Brook Site 2B Dam, there is a 30-inch outlet pipe, with a three-stage reinforced concrete intake riser on the upstream side; acting as the principal spillway. A trapezoidal grassed channel, 90 ft. wide at the control section serves as the emergency spillway. With the pool level at the dam crest, the total spillway capacity is 3800 cfs, whereas at the test flood elevation 105.4', the capacity is 1850 cfs. The crest elevation of the dam is 107.7' which is 5.7 ft. higher than the emergency spillway crest elevation of 102.0'.

5.2 Design Data

Detailed plans, the as-built drawings and the design report are available at the U. S. Department of Agriculture, Soil Conservation Service, Storrs, Connecticut. Required design data are contained therein.

The design test flood inflow for the Farm Brook Reservoir was 7200 cfs and the routed outflow was 5200 cfs with the design high water elevation in the reservoir computed to be 105.7, giving a freeboard of 2.0 ft.

### 5.3 Experience Data

No records are kept of reservoir levels during the times that water is impounded in the Farm Brook Reservoir.

### 5.4 Test Flood Analysis

Based on the dam failure analysis, the Farm Brook Reservoir Site 2B Dam is classified as being 'high' hazard potential in accordance with the Corps of Engineers' Recommended Guidelines for Safety Inspection of Dams. The test flood should be equal to the probable maximum flood (PMF) which was accordingly adopted for analysis.

An inflow peak rate of runoff was calculated for 2.63 square miles of watershed area using a runoff coefficient with a value intermediate between the 'flat & coastal' and 'rolling' terrain curves. The peak inflow rate of 1500 cfs per square miles (csm) was accordingly adopted resulting in a runoff of 4000 cfs. A dam failure outflow of 2000 cfs from the Farm Brook Site 1 project was added to this value resulting in a total PMF of 6000 cfs.

A triangular hydrograph was constructed using the methodology given in the 'Hydrology, Section 4, SCS National Engineering Handbook.' The peak inflow rate of 6,000 cfs with a total runoff of 19.0 inches for the PMF were used to construct the inflow hydrograph.

Flood routing through the reservoir was done with an initial water elevation of 96.5' which was at the crest of the intake riser weir at the principal spillway. The test flood produced a routed outflow discharge of 5980 cfs out of which 4130 cfs will pass over the site 2A spillways and 1850 cfs over the site 2B spillways. The routed outflow 1850 cfs is considerably less

than the maximum spillway capacity of 3800 cfs at the site 2B, the latter being 205% of the former. Considering the peak test flood pool elevation of 105.4' freeboard to the top of the dam is 2.3 ft.

#### 5.5 Dam Failure Analysis

A dam failure analysis was made in accordance with the Corps of Engineers' Guidelines. Failure was assumed with the water level at the test flood elevation of 105.4'. Assuming a dam breach 400 ft. wide (40% of dam length) and 27 ft. high, the peak release rate was 94,000 cfs.

The height of the flood wave was approximately 25.5 ft. at the first cross-section (station 3+0). One more cross-section 950 ft. down from the dam was analyzed. Flood routing computation were done taking into consideration the available valley storage. The resulting flood elevations and the values of the routed flood flows are given in Appendix D. At the second cross-section (sta. 9+50) the flow is 87,000 cfs and the wave height 19 ft. which have considerable potential of causing substantial flooding of the populated areas south of Cooper Lane.

The depths of flow in the brook in the vicinity of 5 houses shown in the drainage area map within the approximate flooding limits are 3 ft. (pre-failure) and 19 ft. (post-failure). These houses located on Cooper Lane are not subject to flooding under test flood conditions. Under dam failure condition, they will be flooded to depths of 1 to 5 feet above their first flood elevations.

Many houses, streets and town roads will be flooded as a

result of dam breach. The economic loss may be 'excessive' and 'more than a few' lives may be lost. As such the Farm Brook Site 2B dam is classified as 'high' hazard potential.

Dam breach calculations are included in Appendix D.

## EVALUATION OF STRUCTURAL STABILITY

### Section 6

#### 6.1 Visual Observations

The visual inspection revealed no structural stability problems; however, three areas of concern were noted. Rutting and exposed earth areas resulting from vehicular trespassing were observed along the crest and/or slopes of the dam and spillway dike embankment. There was minor erosion associated with these areas which could diminish the embankment stability if not controlled.

Seepage flow was observed from the submerged western drain outlet at the impact basin. The source of this flow may be normal embankment and/or foundation seepage; however, since there was no indication of seepage from the eastern outlet, the western outlet flow could be the result of a localized problem. This seepage condition may suggest that a weak area exists within the embankment which could have an adverse effect on its future stability.

Flow from a 36" stormwater culvert, west of the dam, outlets into a partially riprapped waterway located south of the dam. Varying from 20 to 40 ft. of the embankment toe, the waterway is subjected to flooding and scouring during periods of heavy runoff which may pose a danger to the toe of the dam. Although such a condition does not currently exist, a study to evaluate the effects of flooding on the toe of the dam and considering the need to riprap the remaining length is advisable.

## 6.2 Design and Construction Data

Review of the data available indicates that the dam and spillway were adequately designed for structural stability.

## 6.3 Post Construction Changes

A diversion channel in the upper reservoir area was originally constructed in conjunction with Farm Brook Site 2A Dam. Part of the natural flow to Site 2A Dam was diverted to Site 2B Dam to equalize the water inflow to the reservoir areas. Following completion of the project, observations revealed a greatly diminished flow to Site 2A Dam, with an increase in flooding downstream of Site 2B Dam. Therefore, in June 1978, a closure dike was constructed across the diversion channel and two short channels were excavated which returned the brook flow to its original natural drainage pattern. In addition, a 1' x 2' steel plate was bolted across the lower half of the high orifice, resulting in a reduced size opening which decreased the frequency of downstream flooding. The available data does not indicate any other post construction changes.

## 6.4 Seismic Stability

Farm Brook Site 2B Dam is located in Seismic Zone No. 1, and in accordance with Corps of Engineers guidelines, and does not warrant further seismic analysis at this time.

## ASSESSMENT, RECOMMENDATIONS AND REMEDIAL MEASURES

### Section 7

#### 7.1 Project Assessment

##### a. Condition

As assessed by the visual inspection of the site, review of available data and past performance, the project appears to be in good condition. There was no indication of structural instability, but there are areas requiring maintenance and/or monitoring.

Based on the "Preliminary Guidance for Estimating Maximum Probable Discharge" dated March 1978, peak inflow to the Site 2 Reservoir is 6000 cfs; peak outflow at the Site 2B Dam is 1850 cfs with the water level 2.3 feet below the crest of the dam. With the reservoir water level to the top of dam, the spillway capacity is 3,800 cfs which is approximately 205% of the routed test flood outflow.

##### b. Adequacy of Information

An assessment of the condition and stability of the project can be made with the available information.

##### c. Urgency

It is recommended that measure 7.2.2 be implemented within one year of the owner's receipt of this report. The remaining recommendations in Section 7.2 and the remedial measures in Section 7.3 should be carried out within two years.

#### 7.2 Recommendations

It is recommended that the owner employ a qualified registered engineer to:

1. Inspect the dam during the time that floodwater is

impounded in the reservoir with particular attention to locating possible seepage;

2. Determine the origin and significance of the seepage observed from the 8" outlet at the west side of the impact basin.
3. Evaluate the existing waterway located south of the dam considering the present and future flooding effects on the toe of the embankment and the need to riprap the remaining length of the waterway.

The owner should implement the recommendations of the engineer.

### 7.3 Remedial Measures

#### a. Operation and Maintenance Procedures

The following measures should be undertaken by the owner and continued on a regular basis.

1. Develop and implement a downstream warning system to be used in case of emergencies at the dam.
2. Record maximum pool levels during flood impoundment for future reference.
3. Institute a comprehensive program of inspection to be undertaken on a biennial basis by a registered professional engineer qualified in dam inspection. Inspection of the project should be conducted in the Spring at a time when there is minimal vegetative cover.
4. Restore vegetation on the bare earthen areas along the crests and slopes of the dam and emergency spillway dike embankments.
5. Fill in vehicular ruts along the crest of the dam embankment and reestablish sod and vegetation.

6. Locate and, if required, clean out the 8" outlet pipe situated approximately 100 feet west of the noted footpath.
7. Repair concrete at foundation of fence post on concrete impact basin.
8. Remove brush and debris from the trash rack at the high orifice.
9. Remove sediment that has accumulated at the confluence of the downstream channel and the waterway.
10. Ensure the operability of the slide gate at the low level orifice on an annual basis.
11. Control access at project to discourage vehicular trespassing.

#### 7.4 Alternatives

This study has identified no practical alternatives to the above recommendations.

APPENDIX A

INSPECTION CHECKLIST

VISUAL INSPECTION CHECK LIST  
PARTY ORGANIZATION

PROJECT Farm Brook Site 2B Dam

DATE June 2, 1981

TIME Afternoon

WEATHER Cloudy 70's

W.S. ELEV. 85.3 ± U.S. 82 ± DN.S.  
MSL

PARTY:

1. Wesley J Wolf (WW)
2. Larry J. Buckley (LB)
3. Ramesh P. Singhal (RS)
4. Gerald F. Buckley (GB)
5. Glenn Scallia (GS)

DISCIPLINE:

- Hydraulics & Survey
- Geotechnical
- Hydraulics
- Soils & Structures
- Structures

PROJECT FEATURE

INSPECTED BY

- |   |                           |
|---|---------------------------|
| 1. <u>Dam Embankment (Earthfill)</u>      | <u>WW, LB, RS, GB, GS</u> |
| 2. <u>Principal Spillway-Intake Riser</u> | <u>WW, LB, RS, GB, GS</u> |
| 3. <u>Principal Spillway-Impact Basin</u> | <u>WW, LB, RS, GB, GS</u> |
| 4. <u>Emergency Spillway</u>              | <u>WW, LB, RS, GB, GS</u> |
| 5. _____                                  | _____                     |
| 6. _____                                  | _____                     |
| 7. _____                                  | _____                     |
| 8. _____                                  | _____                     |
| 9. _____                                  | _____                     |
| 10. _____                                 | _____                     |

PERIODIC INSPECTION CHECK LIST

PROJECT Farm Brook Site 2B Dam DATE June 2, 1981

PROJECT FEATURE Earthfill Dam NAME WW, LB, RS, GB, GS

DISCIPLINE \_\_\_\_\_ NAME \_\_\_\_\_

AREA ELEVATED	CONDITIONS
<u>DAM EMBANKMENT</u>	
Crest Elevation	107.7' MSL
Current Pool Elevation	85.3' MSL
Maximum Impoundment to Date	Unknown
Surface Cracks	None Observed
Pavement Conditions	N/A
Movement or settlement of crest	Deep ruts 6" with low areas (6"-8")
Lateral movement	None
Vertical alignment	O.K.
Horizontal alignment	Good
Conditions at abutment & at Concrete Structures	Good
Indications of Movement of Structural Items on Slopes	N/A
Trespassing on Slopes	One path on downstream side - Bare areas - minor erosion
Sloughing or Erosion of Slopes or Abutments	Erosion at worn path on O/S slope
Rock Slope Protection-Riprap Failures	Grouted riprap at intake riser in good condition
Unusual Movement or Cracking at or Near Toes	None
Unusual Embankment or Downstream Seepage	None
Piping or Boils	None
Foundation Drainage Features	8" outlet at middle of dam could not be located. 8" outlets at Impact Basin were under water. Seepage was flowing out of West outlet. None observed from east outlet.
Toe Drains	
Instrumentation System	

PERIODIC INSPECTION CHECK LIST

PROJECT Farm Brook Site 2B Dam

DATE June 2, 1981

PROJECT FEATURE Intake Riser &

NAME W, L, R, G, B, G, S

DISCIPLINE Reservoir Area

NAME \_\_\_\_\_

AREA EVALUATED	CONDITION
<u>OUTLET WORKS - INTAKE CHANNEL AND INTAKE STRUCTURE</u>	
a. Approach Channel Slope Conditions Bottom Conditions Rock Slides or Falls Log Boom Debris Condition of concrete lining Drains or Weep Holes	Reservoir Area was clean with virtually no floating debris
b. Intake Structure Condition of Concrete <del>Stop Logs and Slots</del>	Good Condition; Little debris at intake riser. Water level was $\approx$ .2 ft. below the high flow orifice weir. Low flow orifice was closed and under repair. Grouted area at riser was in good condition.

PERIODIC INSPECTION CHECK LIST

PROJECT Farm Brook Site 2B Dam  
 PROJECT FEATURE Impact Basin A  
 DISCIPLINE Downstream Channel

DATE June 2, 1981  
 NAME WW, LB, RS, GB, GS  
 NAME \_\_\_\_\_

AREA EVALUATED	CONDITION
<u>OUTLET WORKS - OUTLET STRUCTURE AND OUTLET CHANNEL</u>	
General Condition of Concrete	[ Good, except for cracked concrete at base of West
Rust or Staining	L fence post* None
Spalling	None
Erosion or cavitation	None Observed
Visible reinforcing	None Observed
Any Seepage or Efflorescence	None
Condition at Joints	Good
Drain Holes	Flow was coming out of west outlet drain which was also submerged
Channel	None
Loose Rock or Trees Overhanging Channel	
Condition of Discharge Channel	Good - Minor weed growth

\* West Fence was tilted. (Two most southern poles.)

PERIODIC INSPECTION CHECK LIST

PROJECT Farm Brook Site 2B Dam DATE June 7, 1991  
 PROJECT FEATURE Emergency Spillway NAME WW, LB, RS, GB, GS  
 DISCIPLINE \_\_\_\_\_ NAME \_\_\_\_\_

AREA EVALUATED	CONDITION
----------------	-----------

OUTLET WORKS - SPILLWAY WEIR, APPROACH AND DISCHARGE CHANNELS

a. Approach Channel (Before Crest) \*\*  
 General Condition Good  
 Loose rock overhanging channel None  
 Trees Overhanging Channel None  
 Floor of Approach Channel Good stable growth of grass

b. Weir and trailing walls  
 General Condition of Concrete  
 Rust or Staining  
 Spalling  
 Any Visible Reinforcing  
 Any Seepage or Efflorescence  
 Drain Holes  
 N/A

c. Discharge Channel (After Crest including Level Section)  
 General Condition Good; \*  
 Loose Rock Overhanging Channel None  
 Trees Overhanging Channel Large tree at southeast corner  
 Floor of Channel Good stable growth of grass.

~~Other Obstructions~~

\*\* Earth exposed on crest, D/S & U/S of dike on west side of Level Section.  
 Minor erosion associated with bare areas

\* Dike along west side of discharge channel was bare on crest & along west slope. No evidence of an erosion problem. Riprap on east slope was stable

APPENDIX B

ENGINEERING DATA

## ENGINEERING DATA CHECKLIST

<u>ITEM</u>	<u>AVAILABILITY</u>	<u>LOCATION</u>
LOCATION MAP	Available	USGS Map
AS-BUILT DRAWINGS	Available	U.S. Soil Conservation Service Storrs, CT.
HYDROLOGIC & HYDRAULIC DATA	Available in Design Report	
SOIL BORINGS	Available in Design Report	
SOIL TESTING	Available in Design Report	
GEOLOGY REPORTS	Available in Design Report	
CONSTRUCTION HISTORY	Not Available	
OPERATION RECORDS	Not Available	
INSPECTION HISTORY	Available	State of Connecticut Department of Environmental Protection
DESIGN REPORT	Available	U.S. Soil Conservation Service Storrs, CT.
DESIGN COMPUTATIONS		
HYDROLOGIC & HYDRAULIC	Available in Design Report	
DAM STABILITY	Available in Design Report	
SEEPAGE ANALYSIS	Available in Design Report	

LOCATION

This floodwater retarding site is located on Farm Brook in the Town of Hamden, Connecticut, and consists of two individual dams. Site 2A is located on Farm Brook on the east side of Paradise Avenue approximately 2000 feet north of Benham Street. Site 2B is located on a tributary of Farm Brook on the west side of Paradise Avenue approximately 500 feet north of Cooper Lane. Refer to sheet 3 of this report for the site locations referenced to the USGS New Haven Quadrangle.

DESIGN

This structure is the main floodwater retarding structure proposed for this watershed. It is in series with an upstream, Class b, multiple-purpose structure. It will retard the runoff from a storm which has a frequency in excess of 100-years without discharge occurring through the emergency spillway.

Elevations of the various structural elements and the related determining factors are listed on sheet 5 of this report. The emergency spillway crest elevation was established approximately 3 feet above the routed peak elevation due to physical limitations at the dam sites.

The design of Site 2 neglected any beneficial effects induced by Site 1, as Site 1 is a Class b structure. However, the effect of a failure at Site 1 due to the occurrence of a Class c emergency spillway design storm on the watershed was considered during the design of Site 2.

A connecting channel from Farm Brook directed toward Site 2B will aid in the simultaneous filling of the two flood pools. It will also aid in preventing flow across Paradise Avenue at the Farm Brook crossing due to the more frequent, short-duration storms.

REFERENCES

Criteria and procedures used in this design are given in the following Soil Conservation Service Publications:

- National Engineering Memorandum No. 27 Limiting Criteria for the Design of Earth Dams
- No. 50 Drop Inlet Spillway Standards
- No. 4 Hydrology
- No. 5 Hydraulics
- No. 6 Structural Design
- No. 8 Geology

HYDROLOGIC CRITERIA AND ROUTING RESULTS

ELEMENT OF STRUCTURE	DETERMINING FACTOR	ELEVATION	SURFACE AREA ACRES	STORAGE		INFLOW		PEAK OUTFLOW C. F. S.
				ACRE-FEET	INCHES*	VOLUME INCHES	PEAK RATE C. F. S.	
INVERT OF ORIFICE	50-yr. Sediment accumulation	85.5	12.5	28	0.20	-	-	-
CREST OF RISER	100-Yr., 6-hr. Storm	96.5	56.0	348 <u>1/</u>	2.48	2.81	1,375	105
CREST OF EMERGENCY SPILLWAY	100-yr., 10-day Storm (Crest elevation used)	99.3	70.8	537 <u>1/</u>	3.83	8.63	1,651	186
DESIGN HIGH WATER	16.5" rainfall, <u>2/</u> 6-hr. duration	102.0	80.1	720 <u>1/</u>	5.14	8.63 <sup>+</sup>	1,651 <sup>+</sup>	201
TOP OF DAM <u>3/</u>	Design high water <u>2/</u> elevation plus 2 feet	105.7	104.7	890 <u>1/</u>	6.35	15.0	7,189	5,200
		107.7	-	1,190 <u>1/</u>	8.49 <u>4/</u>	21.9 <u>4/</u>	10,562 <u>4/</u>	8,374 <u>4/</u>

\* Volume expressed in inches of runoff from controlled watershed area of 1,682 acres.

1/ Does not include sediment storage

2/ State of Connecticut Water Resources Criteria

3/ Maximum elevation as determined by (a) routing SCS Freeboard Storm  
(b) design high water elevation plus 2 feet

4/ Value obtained from SCS freeboard routing.

CONNECTICUT STATE OFFICE, STORRS, CONN.

FARM BROOK SITE 2 STRUCTURE SUMMARY TABLE

ITEM	UNIT	AS BUILT (EXISTING)		WITH ORIFICE PLATE	
		Structure 2A	2B	Structure 2A	2B
Orifice Size	Ft.	-	2 X 2	2 X 2	2 X 1
Orifice Weir Elevation	Ft.	-	83.5	85.5	85.5
Peak Outflow at Elevation 96.5' (Riser Crest)	cfs	129	67	62	31
Drawdown Time Elevation 102.0' - 96.5'	days	1.15	-	-	1.22
Drawdown Time Elevation 96.5' - 85.5'	days	-	-	2.61	-
Drawdown Time Elevation 102.0 - 85.5'	days	3.76	-	-	6.67

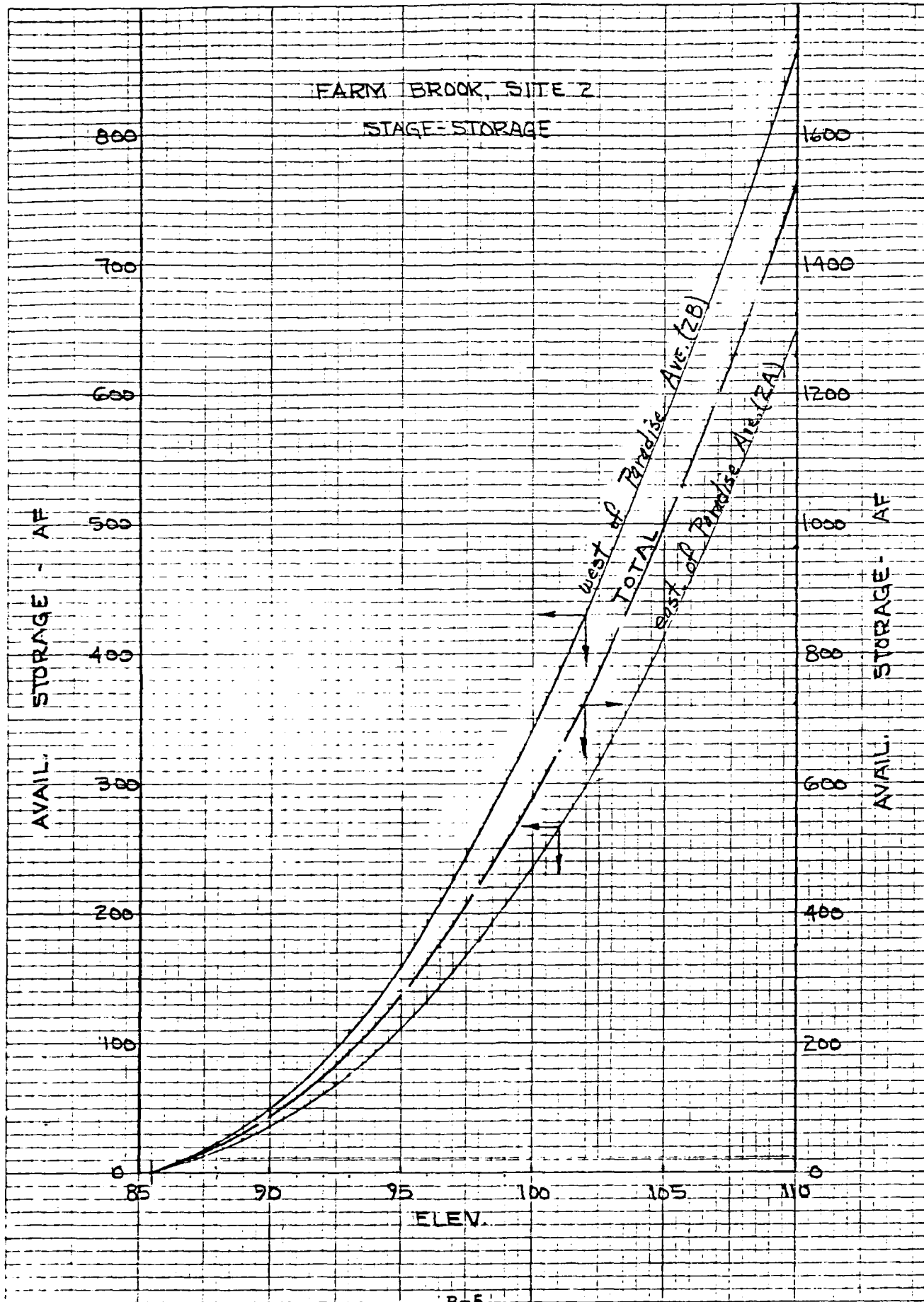

10 X 10 PER INCH

MADE IN U. S. A.

UNITED STATES DEPARTMENT OF AGRICULTURE  
SOIL CONSERVATION SERVICE - Soil Mechanics Laboratory

800 "J" Street, Lincoln, Nebraska 68508

SUBJECT: ENG 22-5, Connecticut WP-08, Farm Brook  
Site No. 2B (New Haven County)

*Handwritten signature*  
DATE: May 8, 1970

TO: T. R. Wire, State Conservation Engineer  
SCS, Storrs, Connecticut

ATTACHMENTS

1. Form SCS-354, Soil Mechanics Laboratory Data, 1 sheet.
2. Form SCS-352, Compaction and Penetration Resistance, 3 sheets.
3. Form SCS-357, Summary - Slope Stability Analysis, 2 sheets.
4. Investigational Plans and Profiles.
5. Form SCS-130, Drain Materials, 1 sheet.

DISCUSSION

FOUNDATION

- A. Classification. Sandy till outwash materials and alluvial deposits blanket the 800-foot wide floodplain to depths greater than 40 feet. The surface one to 4 feet is organic, low-density material.

The disturbed sample 70W1226 (6+25) from the 1.5 to 2.5-foot depths at dam & station 6+25 is an SM material with 43% fines, a liquid limit of 20 and a plasticity index of 2. Sample 70W1227 (12+25) from the 2 to 4.3-foot depths at Station 12+25 is an SC-SM material with 49% fines, a liquid limit of 24 and a plasticity index of 6.

The gently sloping abutments have 10 to 20 feet of till materials overlying sandstone bedrock.

- B. Dry Unit Weight. Standard penetration tests yielded blow counts of 11 to 65 blows per foot in the saturated sandy floodplain materials. The average blow count was generally in the range of 20 to 25 blows/foot.

The surface organic materials had blow counts of 2 to 7 blows/foot.

- C. Consolidation. The average consolidation potential of the upper 20 feet of the sandy floodplain materials is estimated to be approximately 3% under the load of the proposed 23-foot high embankment.

The consolidation potential of the organic surface materials will probably be extremely high.

- D. Permeability. Field permeability tests in the sandy floodplain materials yielded permeability rates of zero to 0.17 ft/day.

The water table was at or near the ground surface.

Subj: Connecticut WP-08, Farm Brook, Site 2B

- E. Shear Strength. The shear strength of the low-blow-count surface organic materials is assumed to be too weak to support the proposed embankment.

The shear strength of the high-blow-count, sandy floodplain materials under the organic surface material is assumed to be greater than that of the compacted embankment materials.

#### EMBANKMENT MATERIALS

- A. Classification. The 3 borrow samples submitted from this site vary from SP-SM material to ML material. The SP-SM sample 70W1228 (129) contains 8% fines. The SM sample 70W1229 (134) contains 32% fines and has a liquid limit of 21 and a plasticity index of 3. The ML sample 70W1230 (135) contains 68% fines and has a liquid limit of 26 and a plasticity index of 3.
- B. Compacted Dry Density. Standard Proctor compaction tests (ASTM D-698, Method A) were made on the minus No. 4 fraction of the 3 borrow samples submitted. The maximum dry densities were 124.5 pcf, 122.5 pcf, and 109.0 pcf, respectively, for the SP-SM, SM, and ML samples. Respective optimum moisture contents were 9.5%, 11.5%, and 17.0%.
- C. Shear Strength. Shear strength of the borrow materials at compacted densities of 95% of standard Proctor are expected to be adequate for the proposed 30-foot high embankment.

Similar SM material from Site No. 1 at 95% of Standard density yielded saturated total stress shear parameters of  $\phi = 36.5^\circ$  and  $c = 150$  psf. The adjacent Site 2A had shear parameters of  $\phi = 33^\circ$  and  $c = 625$  psf for test specimens compacted to 95% of standard Proctor density with moisture contents that were 85% of theoretical saturation.

#### SLOPE STABILITY

The stability of the proposed embankment was checked using the Laboratory slope stability charts. An embankment-only analysis of the 3:1 upstream slope yielded a safety factor of 2.0 for the full drawdown analysis. The downstream  $2\frac{1}{2}$ :1 slope without a drain yielded a safety factor of 1.85 for the steady seepage condition.

#### RECOMMENDATIONS

- A. Site Preparation. Removal of the surface one to 4 feet of soft organic silt is recommended unless it is sampled and tested to prove it is adequate under the proposed embankment.

The water table was at or near the ground surface when the site was investigated, so the site may have to be dewatered to strip it.

- B. Centerline Cutoff. A 3 to 4-foot deep normal width cutoff trench with 1:1 side slopes is recommended in the abutments and across the floodplain, except that in the areas where stripping operations remove over 3 feet of organic materials, a cutoff will not be needed. Backfill the cutoff trench with the finer grained materials like the ML sample 70W1230 (135). Place the backfill with moisture contents at or above optimum and compact to a minimum density of 95% of Standard.
- C. Principal Spillway. The proposed location at the base of the left abutment appears to offer the best foundation conditions for the conduit. Bedrock occurs at depths of 5 to 8 feet along the conduit. Pipe elongation calculations based on a 28-foot high embankment ( $B = 167'$ ) over 5 feet of sandy foundation material (soft surface materials removed) with a consolidation potential of 3% shows a horizontal strain of less than 0.003 ft/ft.

Backfill with fine-grained material like the ML sample 70W1230 (135) and compact to a minimum density of 95% of Standard.

- D. Drainage. A filter drain is suggested to provide positive seepage control near the downstream toe because of the high piping potential of the sandy and silty foundation materials. A 5 to 6-foot deep trench drain at  $c/b = 0.6$  appears to be sufficient.

A filter gradation like that recommended for Site 2A is suggested if the filter material is on the fine side. See the attached Form SCS-130 for gradation.

- E. Embankment Design. The following are recommended:

1. Selectively place the borrow materials to best utilize their wide range of properties. Place the low-permeability, fine-grained ML materials like Sample 70W1230 (135) wet of optimum in a center section to provide an impervious core. Place the highly permeable SP-SM material like Sample 70W1228 (129) in the downstream section to pull the phreatic line down. Place the SM material like Sample 70W1229 (134) in the upstream section.
2. Compact all embankment materials to a minimum density of 95% of Standard Proctor.
3. Provide 3:1 upstream slopes and 2 1/2:1 downstream slopes.
4. A 0.5-foot overfill is recommended to compensate for residual settlement after construction is complete.

ZONES

Prepared by:

Edgar P. Steele  
Edgar P. Steele

T. R. Wire  
Subj: Connecticut WP-08, Farm Brook, Site 2B

4

Reviewed and Approved by:

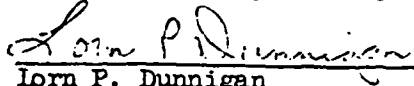
  
\_\_\_\_\_  
Lorn P. Dunnigan  
Head, Soil Mechanics Laboratory

Attachments

cc:

T. R. Wire (1)  
N. Paul Tedrow, State Conservationist, Storrs, Conn. ✓  
W. M. Brown, Geologist, Storrs, Conn.  
Neil F. Bogner, Upper Darby, Pa.

## BIBLIOGRAPHY

1. "Recommended Guidelines for Safety Inspection of Dams", Department of the Army, Office of the Chief Engineers, Washington, D.C. 20314, 1979.
2. Design of Small Dams, Revised Reprint, United States Department of the Interior, Bureau of Reclamation, United States Government Printing Office, Washington, D.C.
3. Soil Survey, Hartford County, Connecticut, United States Department of Agriculture, U.S. Government Printing Office, Washington 25, D.C. 1962
4. Donald M. Gray: Handbook on the Principles of Hydrology, Water Information Center, 1970.
5. Hunter Rouse: Engineering Hydraulics, John Wiley and Sons, New York, 1950.
6. Victor L. Streeter: Fluid Mechanics, McGraw-Hill Book Company, Inc. 1958.
7. S.C.S. National Engineering Handbook, Hydrology Section 4, Soil Conservation Service, U.S. Department of Agriculture, 1972.
8. "Design Report Farmbrook, Site No. 2." U.S. Department of Agriculture, Soil Conservation Service - Storrs, Ct. 1971.

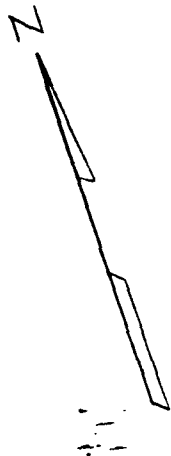

RESERVOIR AREA

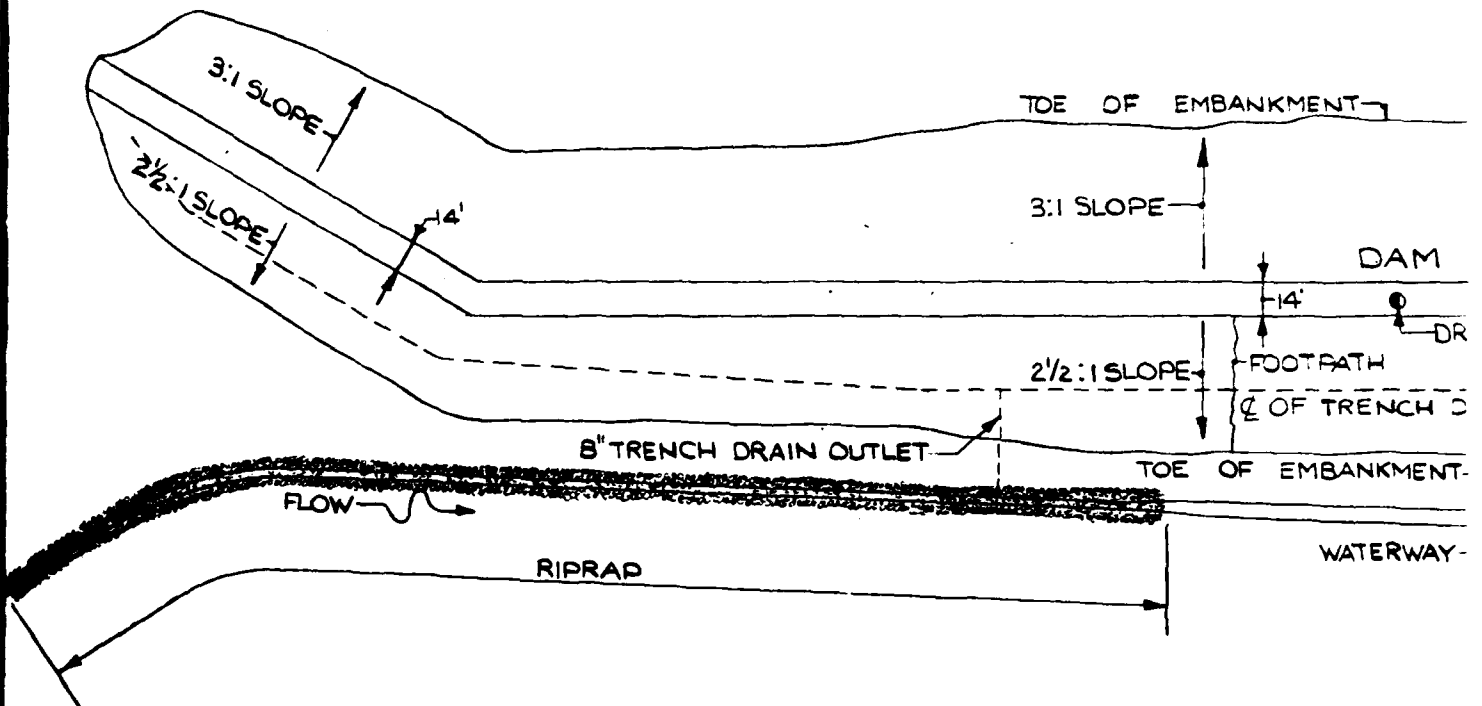

GENERAL PLAN



NOTE

A  
SE

REFER

AS  
SO

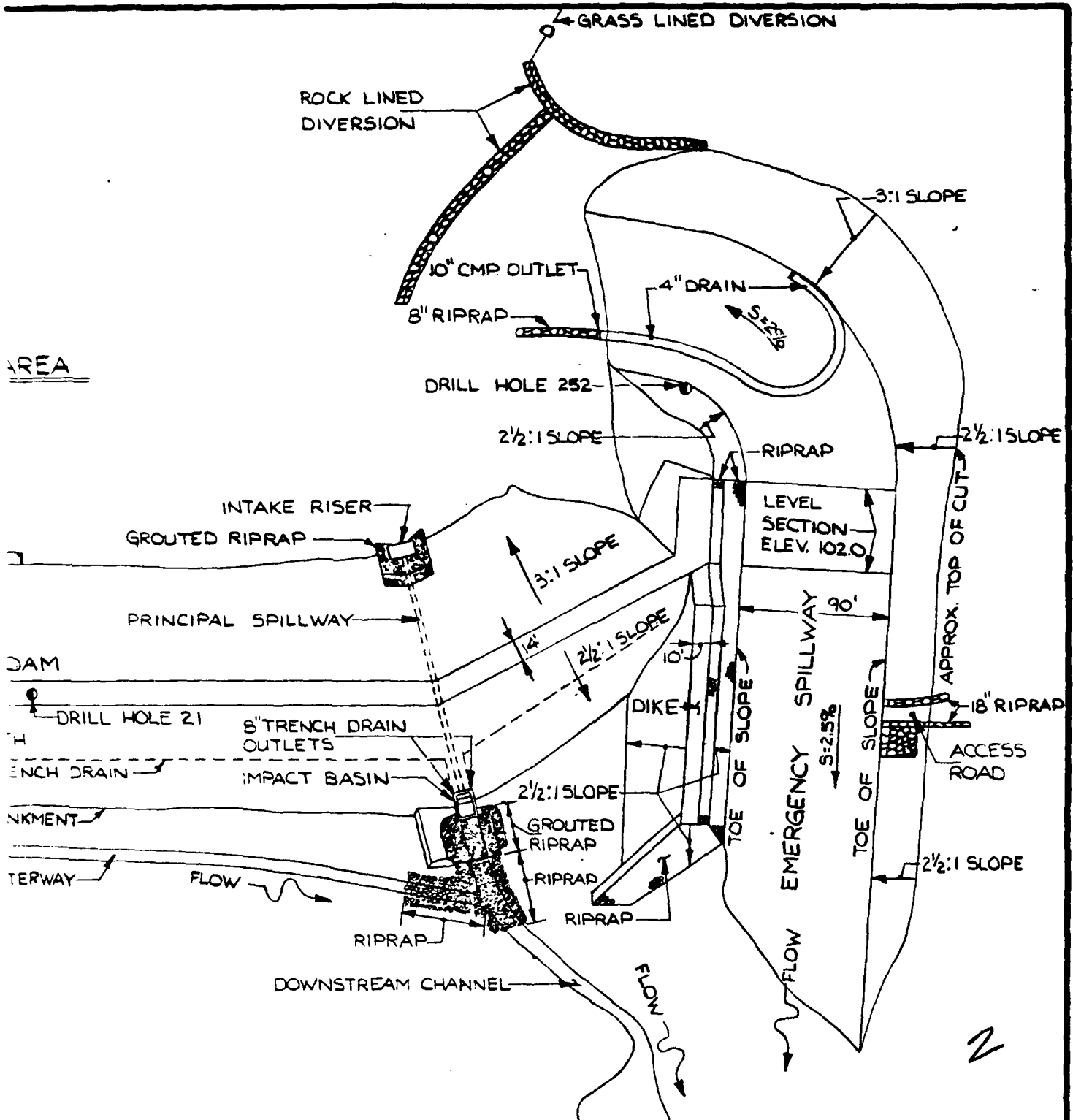

AREA

NOTE:

ALL ELEVATIONS REFERENCED TO MEAN SEA LEVEL.

REFERENCE:

AS BUILT DRAWINGS SUPPLIED BY THE U.S. SOIL CONSERVATION SERVICE STORRS, CONN.

GOODKIND & O'DEA INC. SINGHAL ASSOCIATES, INC. ENGINEERS		U.S. ARMY ENGINEER DIV. NEW ENGLAND CORPS OF ENGINEERS WALTHAM, MASS.	
NATIONAL PROGRAM OF INSPECTION OF NON-FED. DAMS			
GENERAL PLAN			
<b>FARM BROOK SITE 2B DAM</b>			
HAMDEN, CONNECTICUT			
DRAWN BY E.T.R.	CHECKED BY W.J.W.	APPROVED BY L.A.B.	SCALE: AS NOTED DATE SEPT, 1961 SHEET 8-1

2

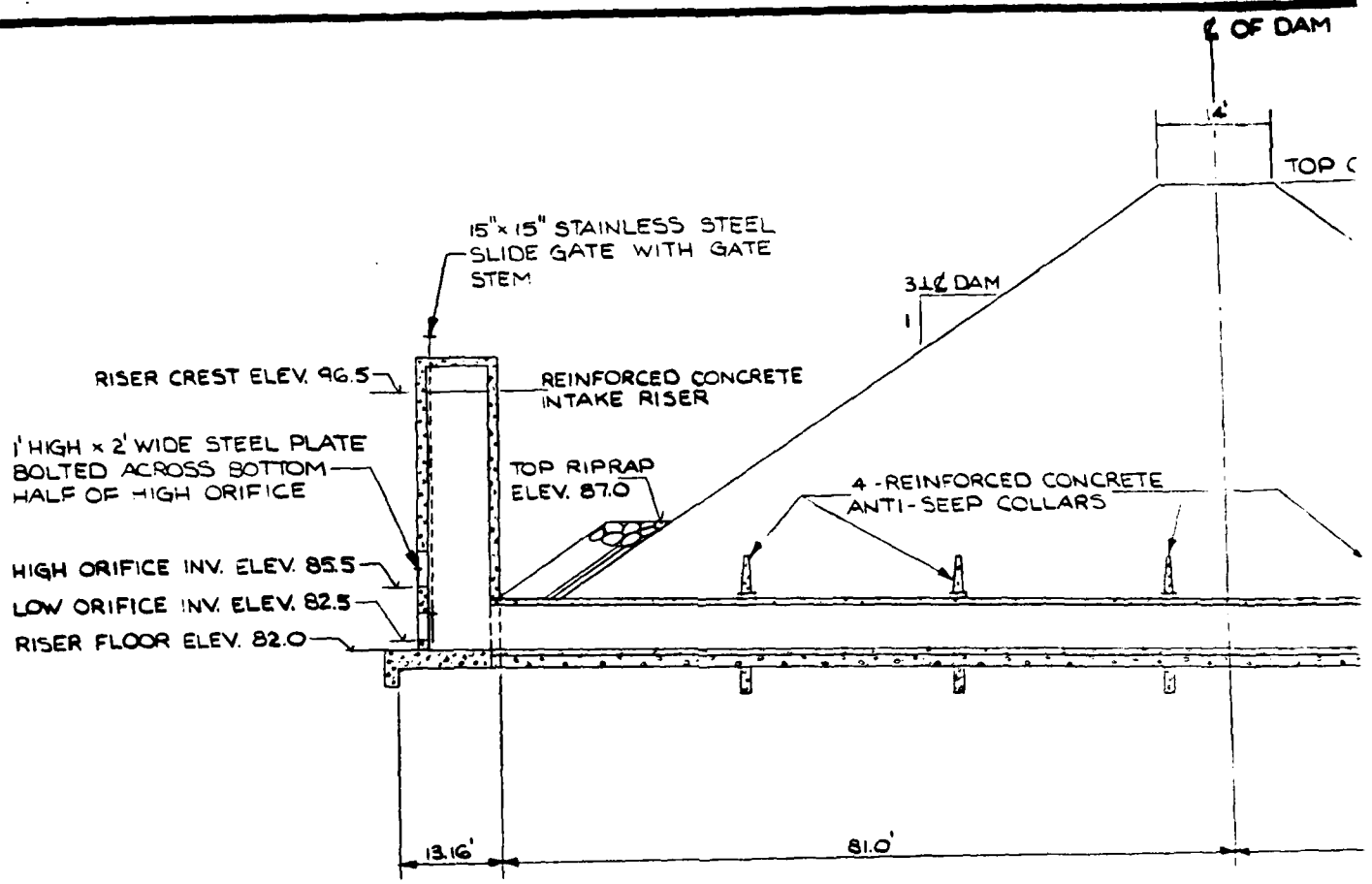

PROFILE ALONG  $\phi$  OF PRINCIPAL

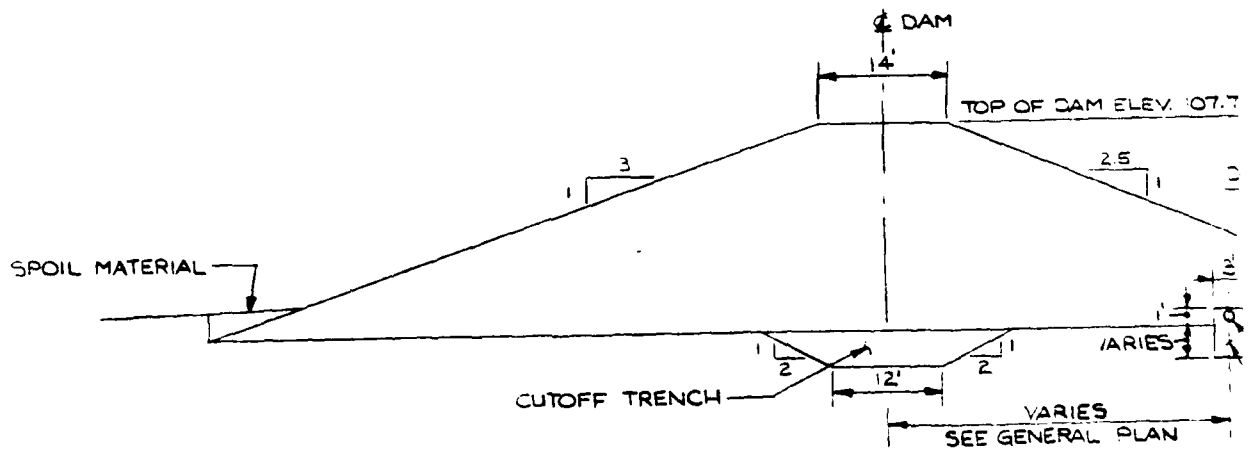
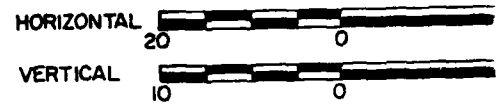

TYPICAL DAM SECTION

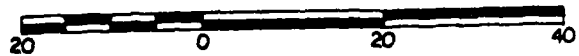

F DAM

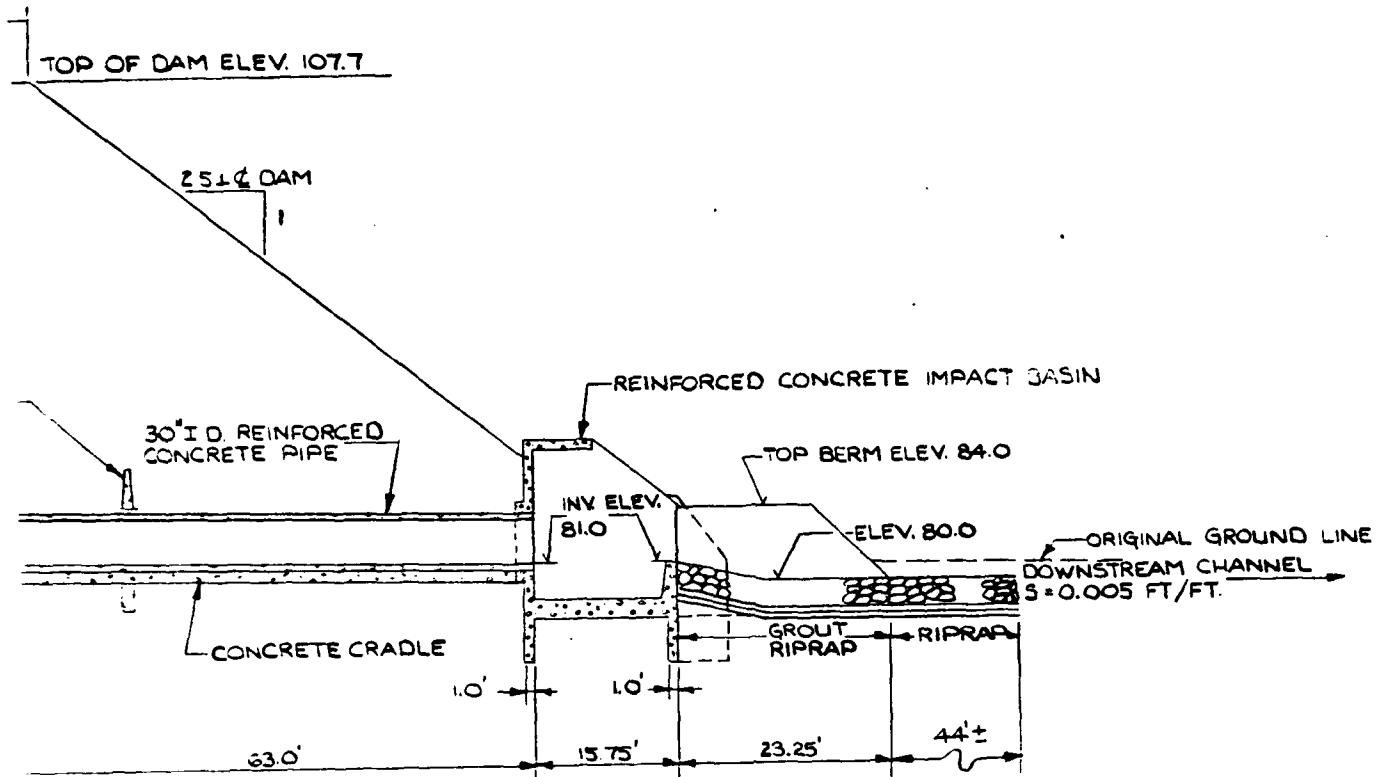

PRINCIPAL SPILLWAY

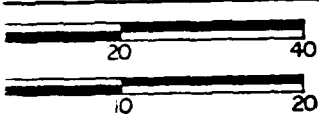

NOTE:

ALL ELEVATIONS REFERENCED TO MEAN SEA LEVEL.

REFERENCE:

AS BUILT DRAWINGS SUPPLIED BY THE U.S. SOIL CONSERVATION SERVICE STORRS, CONN.

ELEV. 107.7

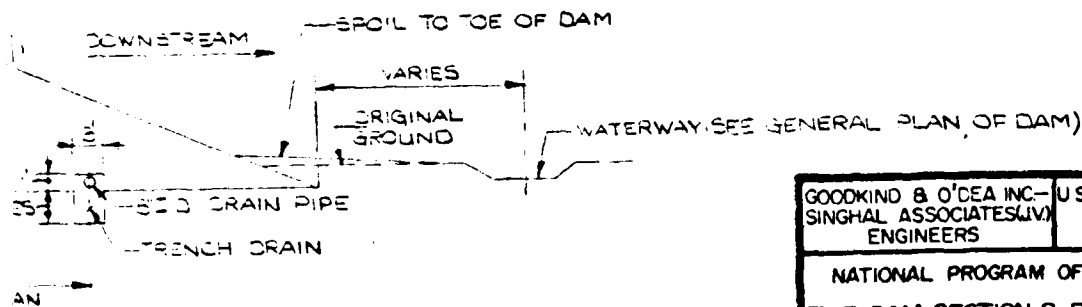

GOODKIND & O'DEA INC.- SINGHAL ASSOCIATES (A/E) ENGINEERS		U.S. ARMY ENGINEER DIV NEW ENGLAND CORPS OF ENGINEERS WALTHAM, MASS.	
NATIONAL PROGRAM OF INSPECTION OF NON-FED DAMS TYP. DAM SECTION & PROFILE OF PRINCIPAL SPILLWAY			
FARM BROOK SITE 2B DAM HAMDEN, CONNECTICUT			
DRAWN BY	CHECKED BY	APPROVED BY	SCALE: AS NOTED
E.T.K.	W.J.W.	L.J.B.	DATE SEPT., 1981 SHEET 0-2

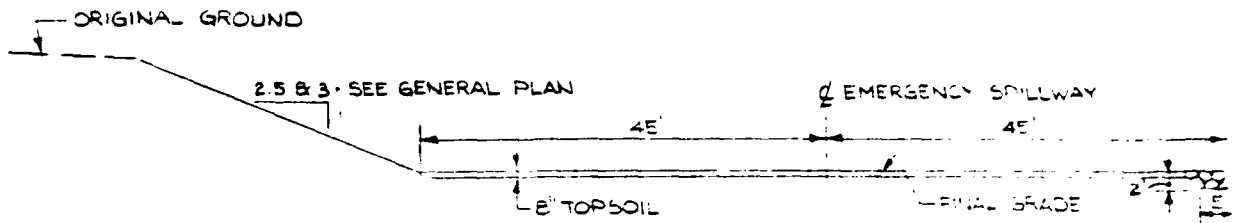

TYPICAL SECTION OF EMERGENCY SPILLWAY

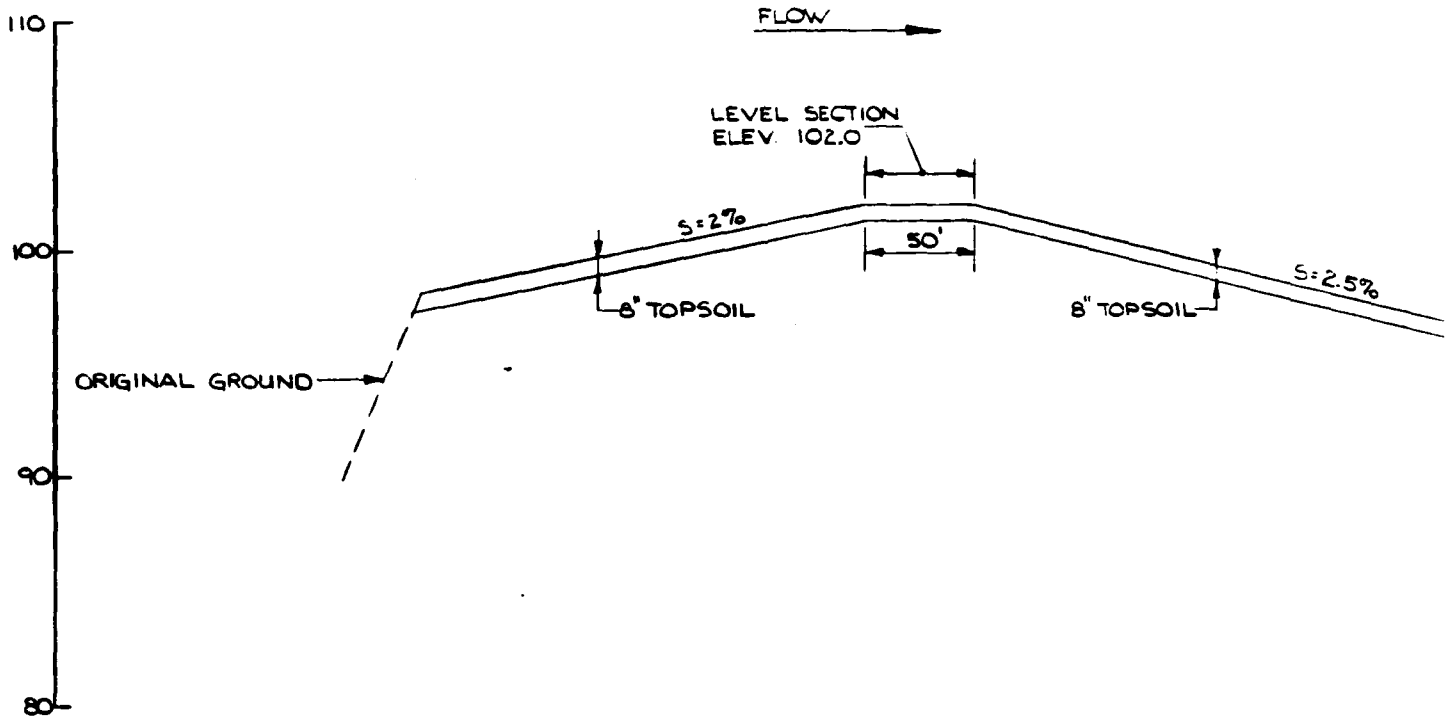
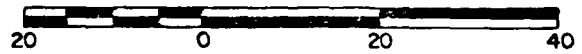

PROFILE ALONG  $\phi$  OF EMERGENCY SPILLWAY

NOT TO SCALE

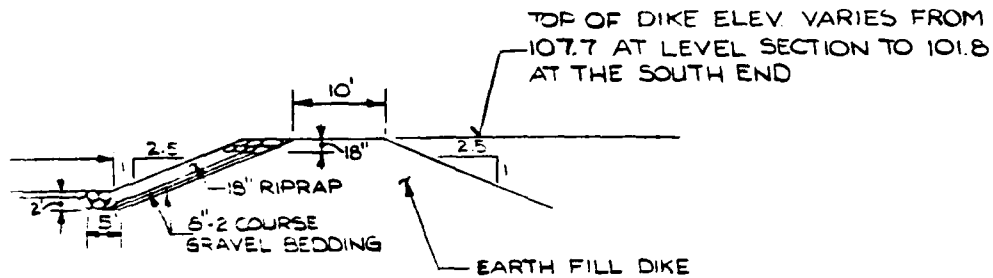

**SPILLWAY**

40

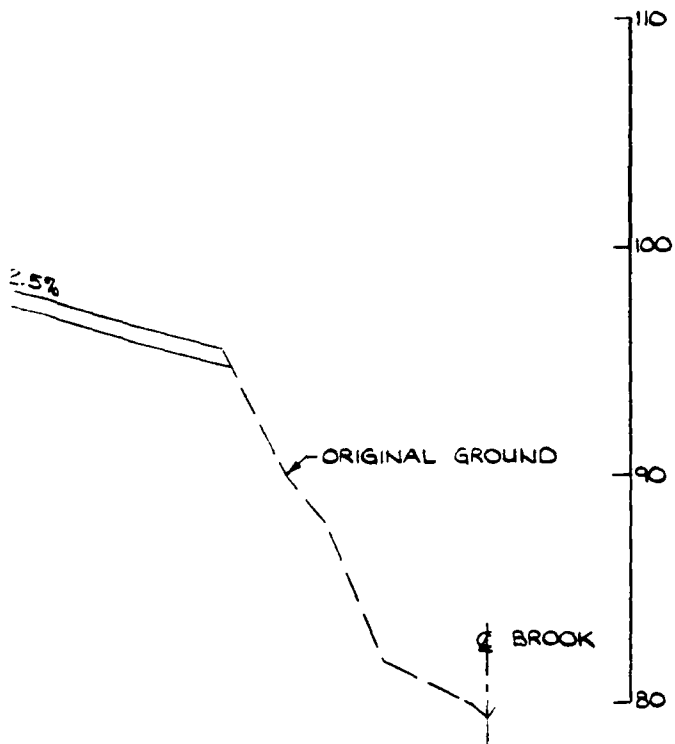

NOTE:

ALL ELEVATIONS REFERENCED TO MEAN SEA LEVEL.

REFERENCE:

AS BUILT DRAWINGS SUPPLIED BY THE U.S. SOIL CONSERVATION SERVICE STORRS, CONN.

GOODKIND & O'DEA INC. SINGHAL ASSOCIATES ENGINEERS	U.S. ARMY ENGINEER DIV. NEW ENGLAND CORPS OF ENGINEERS WALTHAM, MASS.
--	---

NATIONAL PROGRAM OF INSPECTION OF NON-FED. DAMS  
TYP. SECTION & PROFILE OF EMERGENCY SPILLWAY

**FARM BROOK SITE 2B DAM**  
HAMDEN, CONNECTICUT

DRAWN BY E.T.K.	CHECKED BY W.J.W.	APPROVED BY L.J.B.	SCALE: AS NOTED	DATE: SEPT. 1981	SHEET 0-3
--------------------	----------------------	-----------------------	-----------------	------------------	-----------

2

DH-21, Elev. 83.3, Sta. 8+95, Centerline of Dam

DH-252, Elev. 110

\*180' U.S. Cer

W.L. - 5/11/67

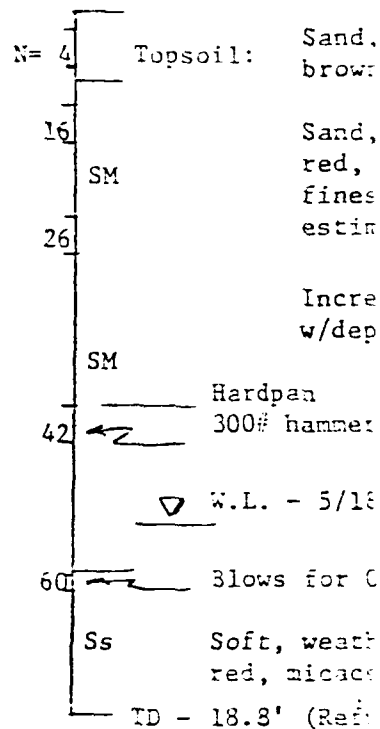
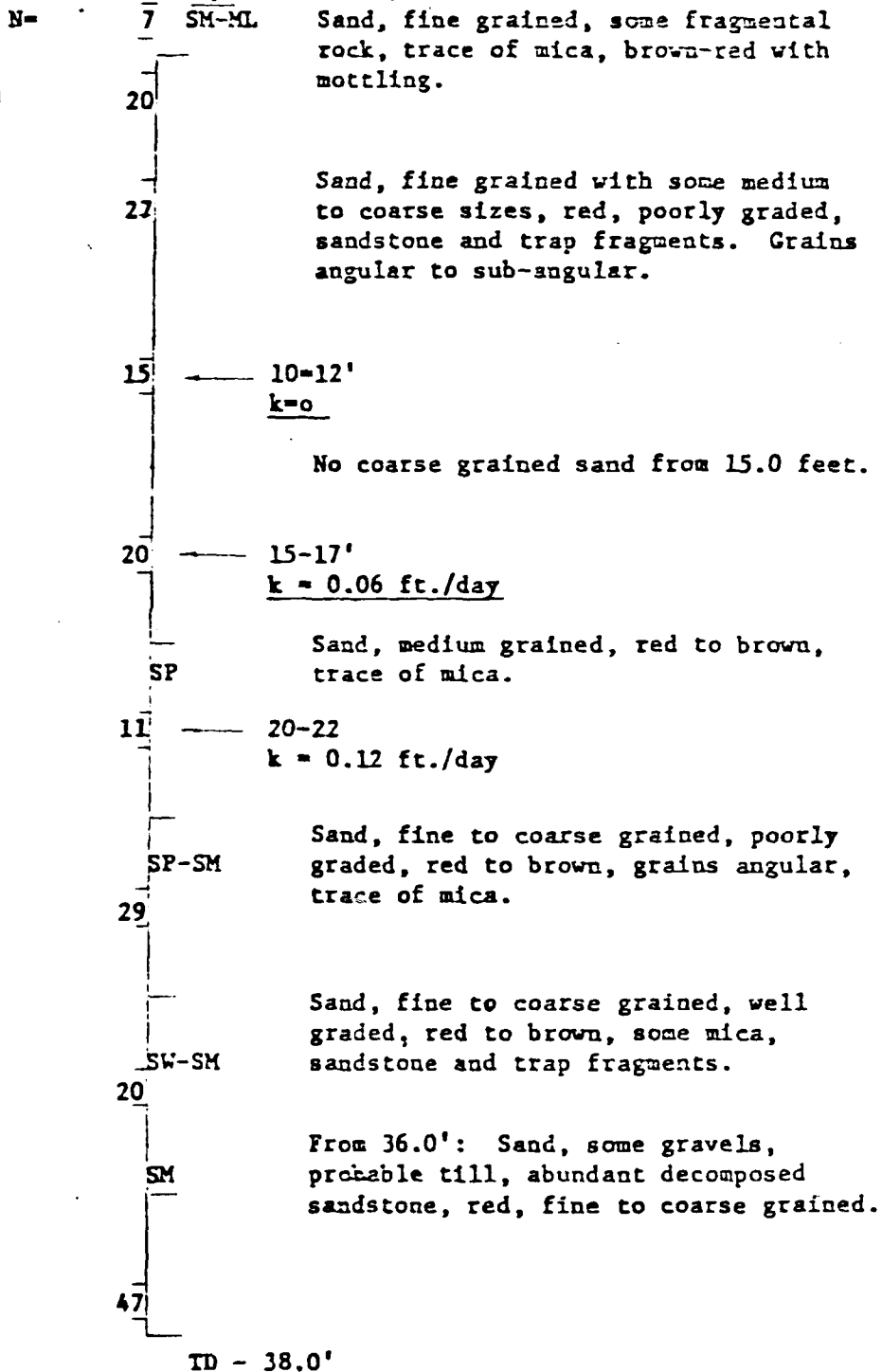

lev. 110.5, Sta. 5+00\*

U.S. Centerline Dam

Sand, fine grained, poorly graded,  
brown, roots, low plastic fines.

Sand, fine grained, poorly graded,  
red, slightly micaceous, low plastic  
fines, some weathered sandstone  
estimated < 5%.

Increased fragmental sandstone  
w/depth.

pan  
hammer/30" Drop

- 5/18/67 Sampler refused at 15.4'.  
Fragmental sandstone in  
s for 0.4' sampler.

, weathered sandstone, fine grained,  
micaceous. Triassic New Haven Arkose.  
' (Refusal)

NOTE:

1) ALL ELEVATIONS REFERENCED TO MEAN SEA  
LEVEL.

2) SEE SHEET B-1 "GENERAL PLAN OF DAM" FOR  
DRILL HOLE LOCATIONS.

3) SEE AS BUILT DRAWINGS FOR ADDITIONAL  
SUBSURFACE SOIL DATA.

REFERENCE:

AS BUILT DRAWINGS SUPPLIED BY U.S. SOIL  
CONSERVATION SERVICE STORRS, CONN.

GOODKIND & O'DEA INC- SINGHAL ASSOCIATES(LV) ENGINEERS	U.S. ARMY ENGINEER DIV. NEW ENGLAND CORPS OF ENGINEERS WALTHAM, MASS.			
NATIONAL PROGRAM OF INSPECTION OF NON-FED. DAMS TYPICAL DRILL HOLES FARM BROOK SITE 2B DAM HAMDEN, CONNECTICUT				
DRAWN BY E.T.R.	CHECKED BY W.A.W.	APPROVED BY L.J.B.	SCALE: AS NOTED DATE: SEPT., 1981	SHEET B-4

APPENDIX C

DETAIL PHOTOGRAPHS

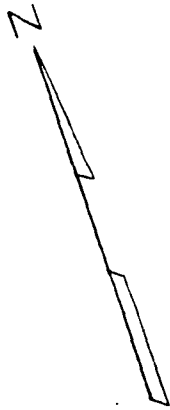

RESERVOIR AREA

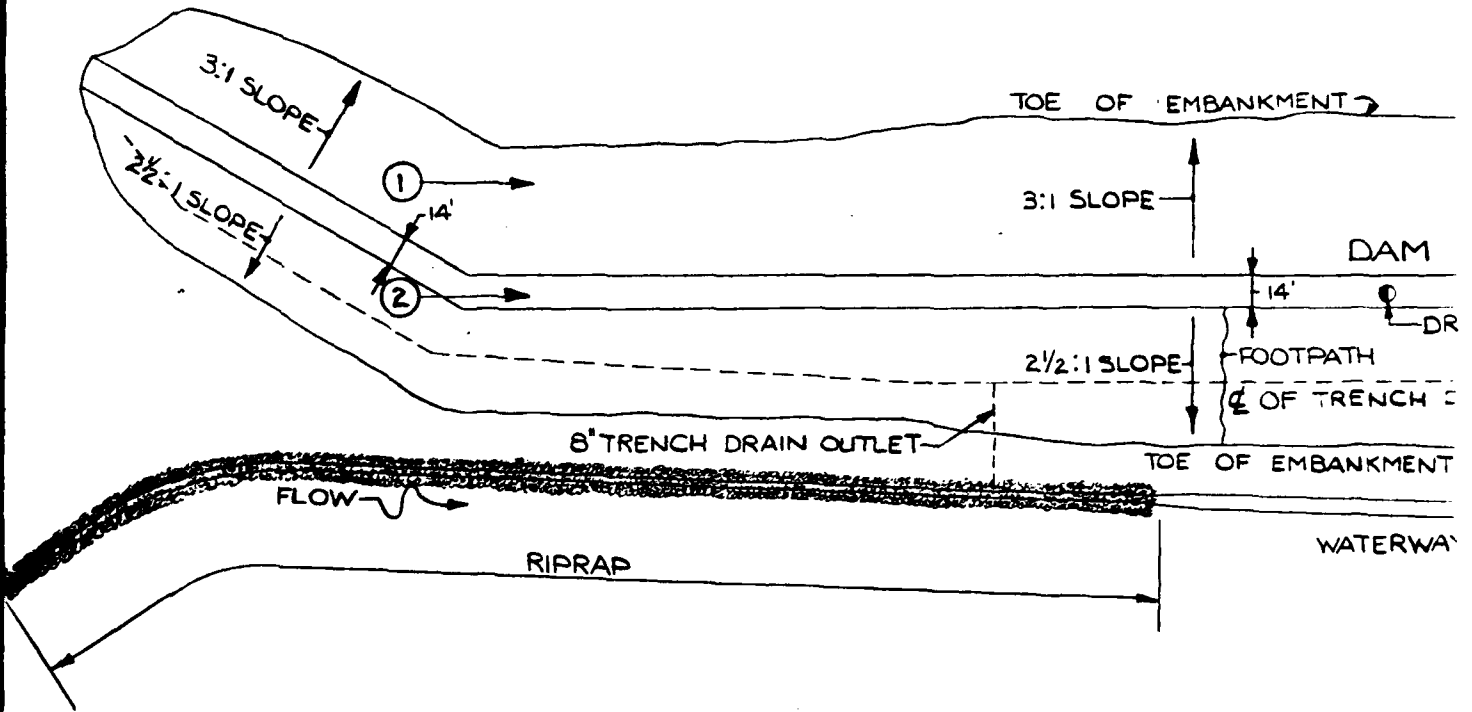

PHOTO LOCATION PLAN



NOTE

A  
SE

REFERE

AE  
SC

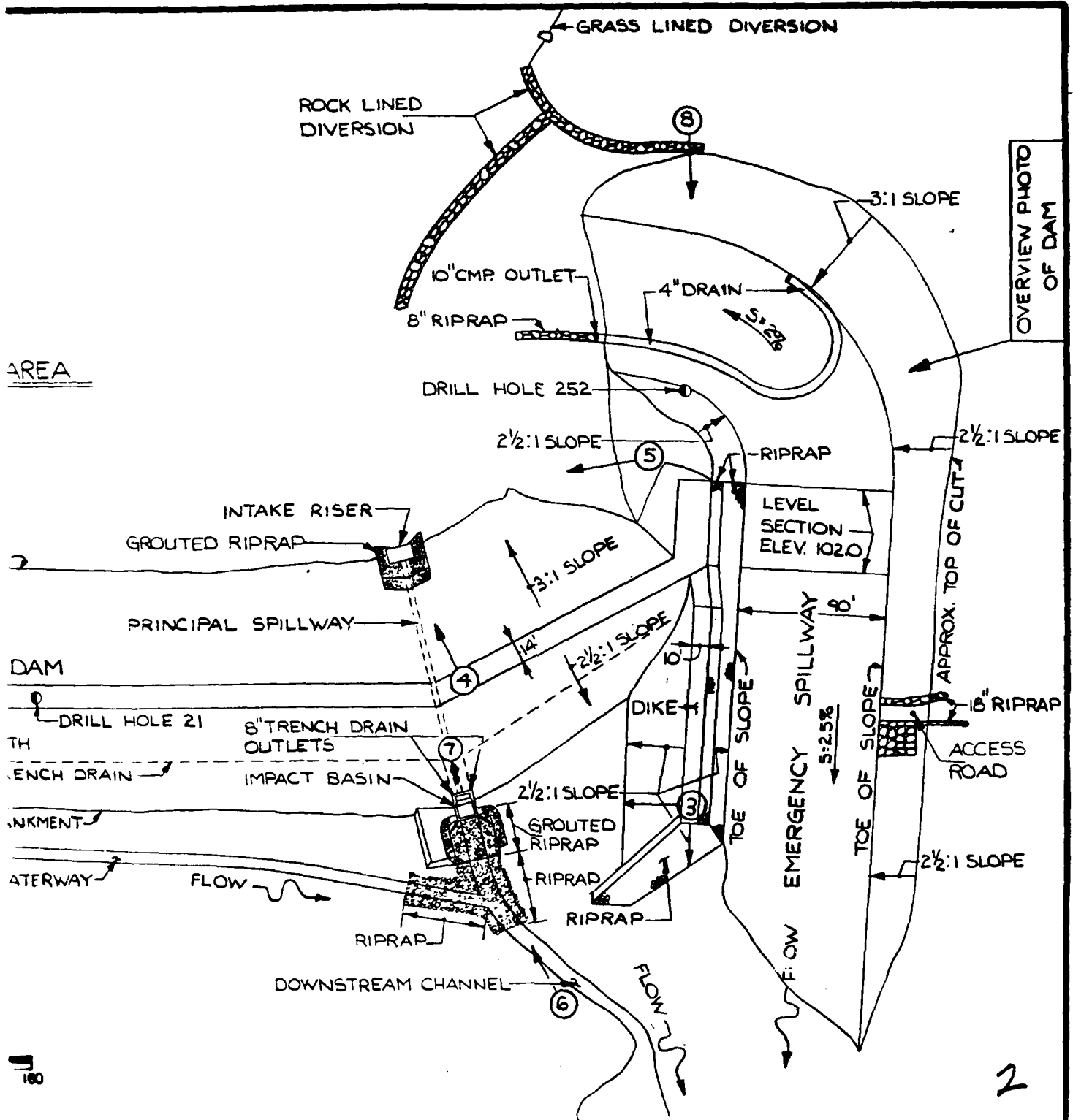

AREA

DAM

OVERVIEW PHOTO OF DAM

**NOTE:**  
ALL ELEVATIONS REFERENCED TO MEAN SEA LEVEL.

**REFERENCE:**  
AS BUILT DRAWINGS SUPPLIED BY THE U.S. SOIL CONSERVATION SERVICE STORRS, CONN.

GOODKIND & O'DEA INC.- SINGHAL ASSOCIATES, INC. ENGINEERS		U.S. ARMY ENGINEER DIV. NEW ENGLAND CORPS OF ENGINEERS WALTHAM, MASS.	
NATIONAL PROGRAM OF INSPECTION OF NON-FED. DAMS			
PHOTO LOCATION PLAN			
<b>FARM BROOK SITE 2B DAM</b>			
HAMDEN, CONNECTICUT			
DRAWN BY E.T.K.	CHECKED BY W.J.W.	APPROVED BY L.A.B.	SCALE: AS NOTED DATE: SEPT., 1981
			SHEET C-1

2



Photo 1 - View of upstream embankment  
slope looking east



Photo 2 - View of embankment crest looking  
east. Note vehicular ruts.

C-1

Note:  
Photos taken June 2, 1981



Photo 3 - Downstream embankment slope.



Photo 4 - Upstream reservoir area with intake riser in foreground

Note:  
Photo 3 taken July 23, 1981  
Photo 4 taken June 2, 1981



Photo 5 - Reinforced concrete intake riser. Note grouted riprap.

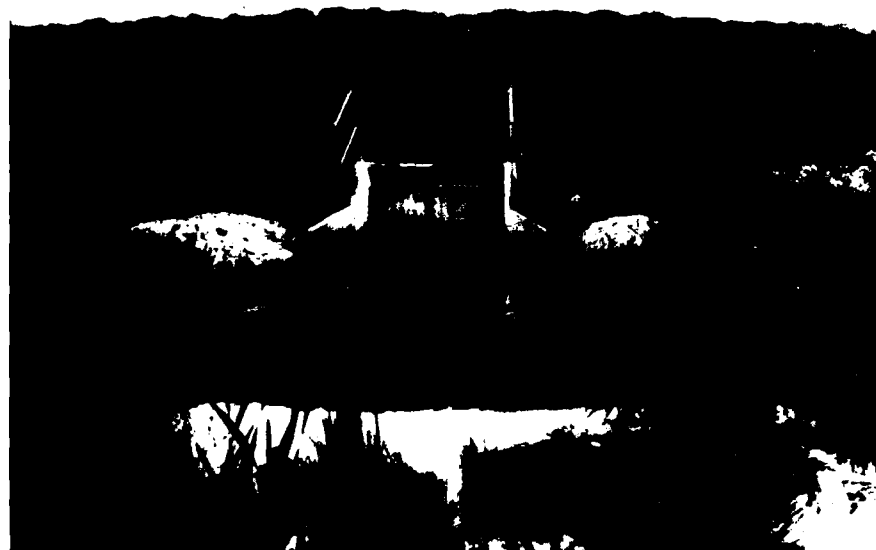

Photo 6 - Reinforced concrete impact basin. Note tilted chain linked fence.

Note:  
Photos taken June 2, 1981



Photo 7 - Downstream Channel

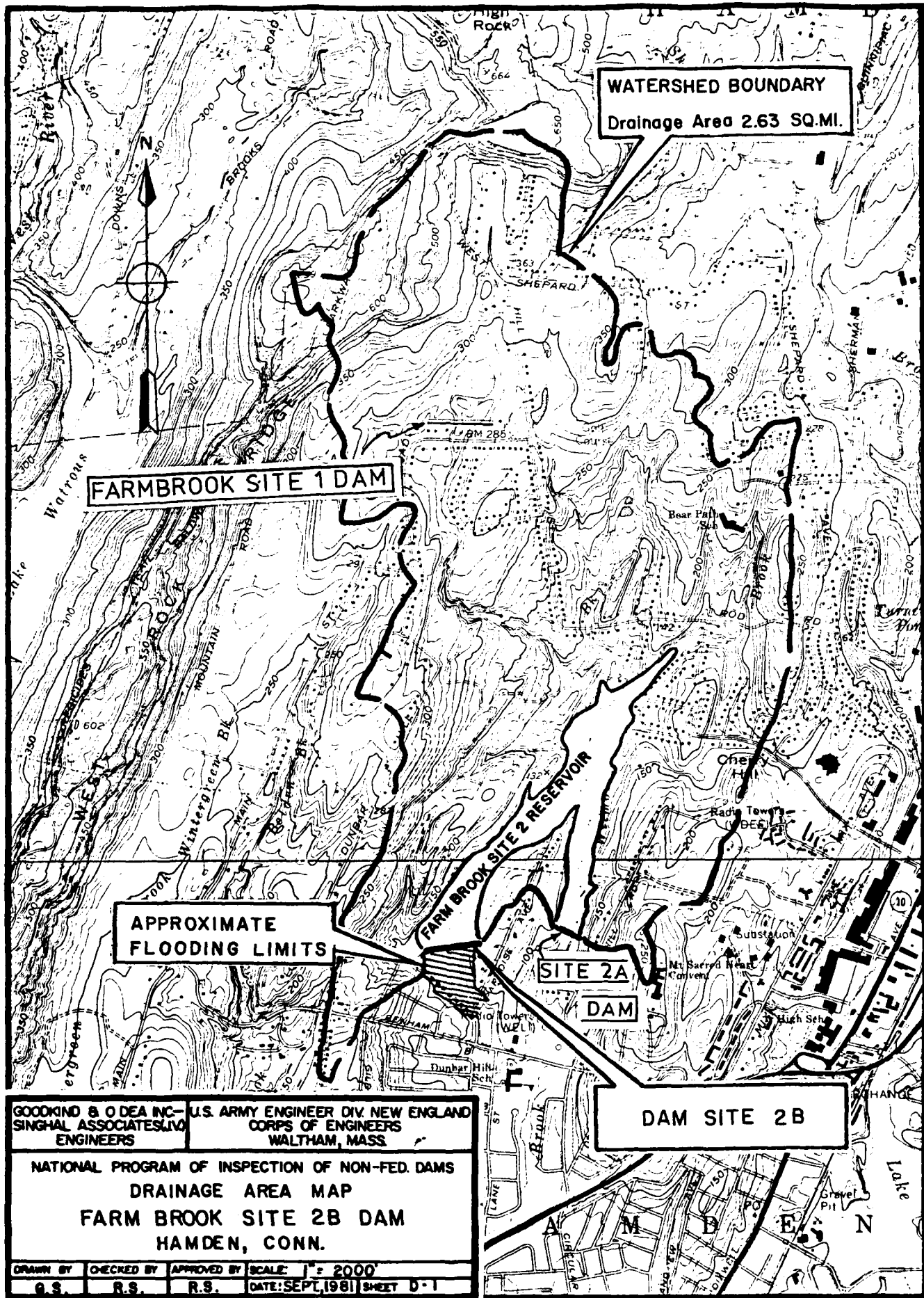

Photo 8 - View of emergency spillway  
looking south. Note eroded area  
on crest of dike.

Note:  
Photos taken June 2, 1981

APPENDIX D

HYDROLOGIC AND HYDRAULIC COMPUTATIONS



**WATERSHED BOUNDARY**  
Drainage Area 2.63 SQ.MI.

**FARMBROOK SITE 1 DAM**

**APPROXIMATE FLOODING LIMITS**

**SITE 2A DAM**

**DAM SITE 2B**

GOODKIND & O'DEA INC.-SINGHAL ASSOCIATES INC. ENGINEERS  
U.S. ARMY ENGINEER DIV. NEW ENGLAND CORPS OF ENGINEERS WALTHAM, MASS.

NATIONAL PROGRAM OF INSPECTION OF NON-FED. DAMS  
DRAINAGE AREA MAP  
FARM BROOK SITE 2B DAM  
HAMDEN, CONN.

DRAWN BY	CHECKED BY	APPROVED BY	SCALE
R.S.	R.S.	R.S.	1" = 2000'
DATE: SEPT. 1981			SHEET D-1

# SINGHAL ASSOCIATES

CONSULTING ENGINEERS

(CIVIL, HYDRAULICS, SANITARY)

827 MAPLEDALE ROAD, ORANGE, CT 06477

TEL: (203) 795-6562

Job FARMBROOK SITE 28

Sheet Number D-1

Date 7.14.1981

By R.S./G.S.

## TEST. FLOOD

THE PROJECT RECEIVES RUNOFF FROM A DRAINAGE AREA OF 2.63 SQ. MILES. THE TERRAIN HAS AN AVERAGE SLOPE OF 4.6%.

AS PER THE CORPS OF ENGINEER'S CHART A FACTOR OF 1500 CFS/SQ. MI BETWEEN 'ROLLING' AND FLAT & COASTAL TERRAIN WAS SELECTED.

$RUNOFF = 1500 \times 2.63 = 3945 \text{ CFS.}$   
ADDING FARMBROOK SITE #1 DAM BREACH OUTFLOW OF 2000 CFS  
TOTAL PMF. =  $3945 + 2000 = 5945$  SAY 6000 CFS.  
SIZE AND HAZARD CLASSIFICATION

MAXIMUM HEIGHT OF DAM = 28 FT.

MAXIMUM IMPOUNDMENT UPTO  
TOP OF DAM = 1196 AC-FT.

THE IMPOUNDMENT LIES BETWEEN THE LIMITS 1000 AC-FT. AND 50,000 AC-FT. AS SUCH THE SIZE OF THE DAM = "INTERMEDIATE" ALTHOUGH THE HEIGHT OF THE DAM DOES NOT EXCEED 40 FT.

THE HAZARD POTENTIAL IS 'HIGH' DUE TO THE EXISTENCE OF MANY STREETS, ROADS, PUBLIC AND PRIVATE BUILDINGS THAT WILL BE FLOODED IN THE EVENT OF DAM FAILURE. THERE IS POTENTIAL FOR 'EXCESSIVE' ECONOMIC LOSS IN ADDITION TO LOSS OF 'MORE THAN FEW' LIVES.

AS PER TABLE 3 PAGES D-12, D-13 OF "THE RECOMMENDED GUIDELINES FOR SAFETY INSPECTION OF DAMS" THE RECOMMENDED TEST FLOOD,

= PMF

= 6,000 CFS.

**SINGHAL ASSOCIATES**

**CONSULTING ENGINEERS**

(CIVIL, HYDRAULICS, SANITARY)

827 MAPLEDALE ROAD, ORANGE, CT 06477

TEL: (203) 795-6562

Job FARM BROOK SITE 2B

Sheet Number D-2

Date 7-14-1981

By K.S./G.S.

SPILLWAY CAPACITY (SITE 2A)

THE SPILLWAY AT SITE 2A CONSISTS OF THE FOLLOWING :

1- 30" RC WATER PIPE (INV. 80.0) WITH  
ONE 1.25'x1.25' LOW-ORIFICE (INV. 80.5)  
ONE 2'x2' HIGH-ORIFICE (INV. 83.5)  
15' WIDE RISER WEIR (CREST ELEV. 96.5)

1- EMERGENCY SPILLWAY 210' WIDE AT  
THE CONTROL SECTION, WITH CREST  
ELEVATION 102.0

SPILLWAY CAPACITIES AT VARIOUS ELEVATIONS FOR  
SITE 2A ARE TABULATED BELOW :

ELEVATION	SPILLWAY CAPACITY (SITE 2A) - CFS		
	PRINCIPAL SPILLWAY	EMERGENCY SPILLWAY $Q = 3 \times 210 \times H^{3/2}$	TOTAL
96.5	100	0	100
98.0	103	0	103
99.0	106	0	106
100.0	109	0	109
101.0	112	0	112
102.0	115	0	115
103.0	117	630	747
104.0	120	1780	1900
105.0	122	3273	3395
106.0	125	5040	5165
107.0	127	7043	7170
107.7	130	8570	8700

**SINGHAL ASSOCIATES**

**CONSULTING ENGINEERS**  
(CIVIL, HYDRAULICS, SANITARY)

827 MAPLEDALE ROAD, ORANGE, CT 06477  
TEL: (203) 795-6562

Job FARMBROOK SITE 2B  
Sheet Number D-3  
Date 7-14-1981  
By R.S./G.S.

SPILLWAY CAPACITY (SITE 2B)

THE SPILLWAY AT SITE 2B CONSISTS OF THE FOLLOWING:

- 1- 30" RC WATER PIPE (INV. 82.0)
- ONE 1.25'x1.25' LOW ORIFICE (INV. 82.5)
- ONE 1'x2' HIGH ORIFICE (INV. 85.5)
- 15' WIDE RISER. WEIR (CREST ELEV. 96.5)

- 1- EMERGENCY SPILLWAY 90' WIDE AT THE CONTROL SECTION, WITH CREST ELEV. 102.0

SPILLWAY CAPACITIES AT VARIOUS ELEVATIONS FOR SITE 2B ARE TABULATED BELOW:

ELEVATION	SPILLWAY CAPACITY (SITE 2B) - CFS		
	PRINCIPAL SPILLWAY	EMERGENCY SPILLWAY $Q = 3 \times 90 \times H^{3/2}$	TOTAL
96.5	100	0	100
98.0	103	0	103
99.0	106	0	106
100.0	109	0	109
101.0	112	0	112
102.0	115	0	115
103.0	117	270	387
104.0	120	765	885
105.0	122	1403	1525
106.0	125	2160	2285
107.0	127	3018	3145
107.7	130	3670	3800

**SINGHAL ASSOCIATES**

**CONSULTING ENGINEERS**  
(CIVIL, HYDRAULICS, SANITARY)

827 MAPLEDALE ROAD, ORANGE, CT 06477  
TEL: (203) 795-6562

Job FARMBROOK SITES 2B  
Sheet Number D-4  
Date 7.15.1981  
By R.S./G.S.

COMBINED SPILLWAY CAPACITY OF  
SITE 2 ( SITE 2A + SITE 2B )

ELEVATION	SPILLWAY CAPACITY SITES 2A+2B (CFS)		
	PRINCIPAL SPILLWAYS	EMERGENCY SPILLWAYS	TOTAL
96.5	200	0	200
98.0	206	0	206
99.0	212	0	212
100.0	218	0	218
101.0	224	0	224
102.0	230	0	230
103.0	234	900	1134
104.0	240	2545	2785
105.0	244	4676	4920
106.0	250	7200	7450
107.0	254	10061	10315
107.7	258	12246	12500

**SINGHAL ASSOCIATES**

**CONSULTING ENGINEERS**

(CIVIL, HYDRAULICS, SANITARY)

827 MAPLEDALE ROAD, ORANGE, CT 06477

TEL: (203) 795-6562

Job FARMBROOK SITE 2B

Sheet Number D-5

Date 7.15.1981

By DS/GS.

SITE 2 (2A+2B) SPILLWAY CAPACITY CURVE

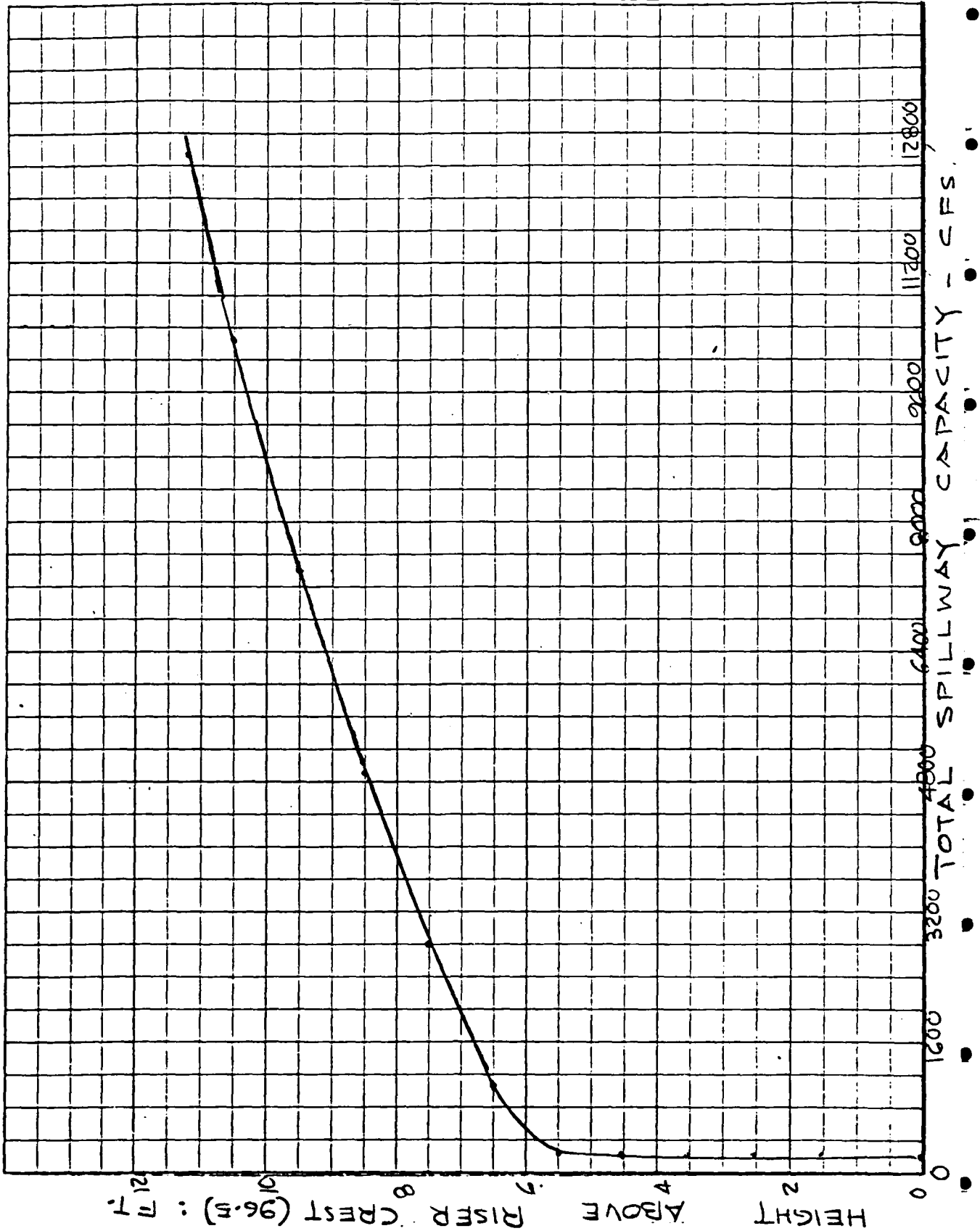

SINGHAL ASSOCIATES

CONSULTING ENGINEERS  
(CIVIL, HYDRAULICS, SANITARY)

827 MAPLEDALE ROAD, ORANGE, CT 06477  
TEL: (203) 795-6562

Job FARMBROOK SITE 2B

Sheet Number D-6

Date 7-15-1981

By R.S./G.S.

SURCHARGE STORAGES  
AND WATER SURFACE AREAS  
FOR THE RESERVOIR

RESERVOIR WATER SURFACE ELEVATION	HEIGHT ABOVE RISED CREST OF EMERGENCY SPILLWAY (FT.)	WATER SURFACE AREA (ACRES)	SURCHARGE STORAGE CAPACITY (AC-FT.)
96.5	0.0	56.0	0.0
98.0	1.5	63.0	100.0
99.0	2.5	68.0	175.0
100.0	3.5	72.0	237.0
101.0	4.5	77.0	310.0
102.0	5.5	80.0	372.0
103.0	6.5	86.0	412.0
104.0	7.5	92.0	450.0
105.0	8.5	98.0	500.0
106.0	9.5	107.0	570.0
107.0	10.5	113.0	675.0
107.7	11.2	120.0	842.0

**SINGHAL ASSOCIATES**

**CONSULTING ENGINEERS**  
(CIVIL, HYDRAULICS, SANITARY)

827 MAPLEDALE ROAD, ORANGE, CT 06477  
TEL: (203) 795-6562

Job FARMBROOK SITE 2B  
Sheet Number D-7  
Date 7-15-1981  
By R.S./G.S.

WATER IN ISL (FA) (ACRES)

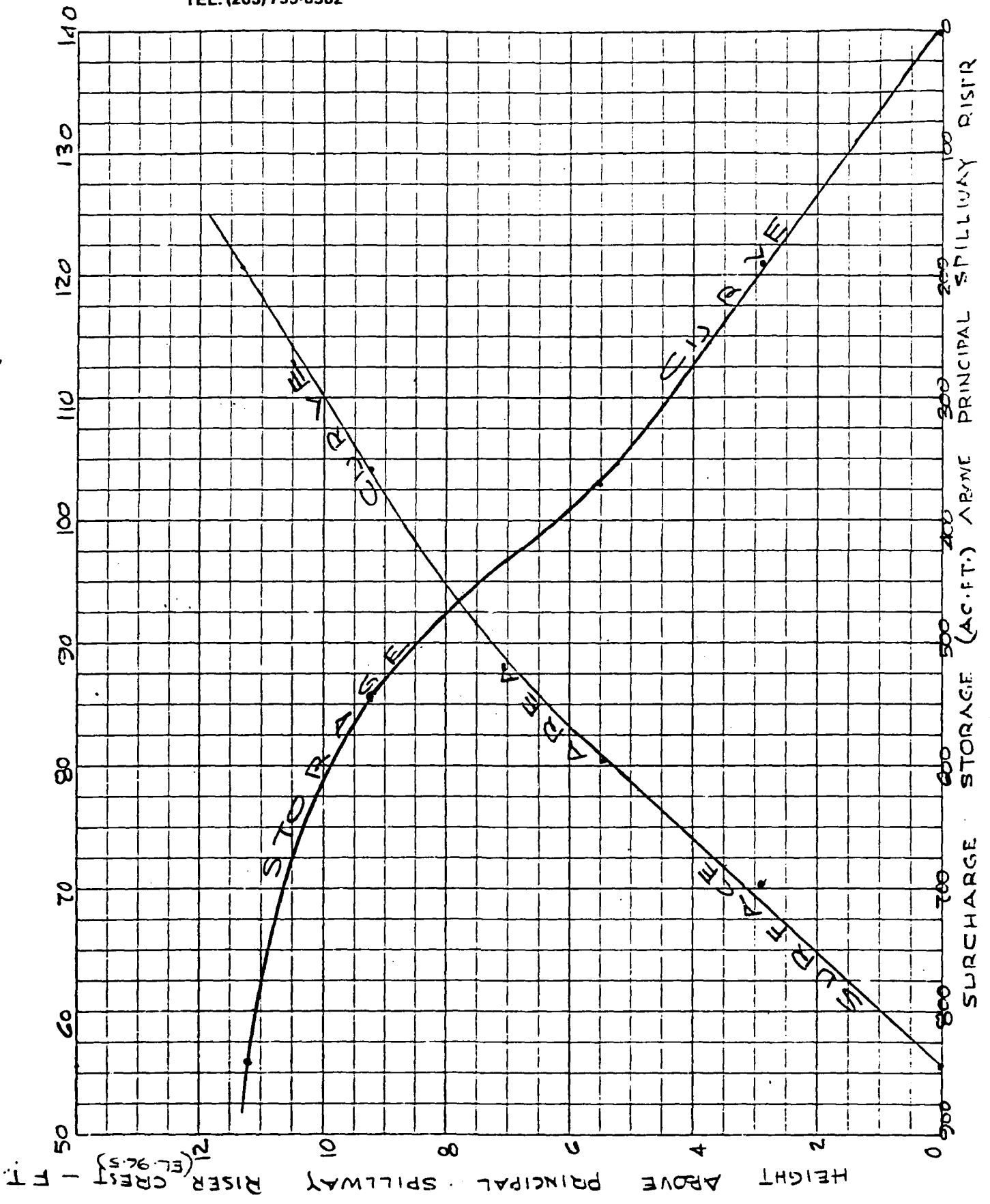

STORAGE (AC.FT.) ABOVE PRINCIPAL SPILLWAY RISER

HEIGHT ABOVE PRINCIPAL SPILLWAY RISER (EL. 96.5) FT.

SINGHAL ASSOCIATES  
CONSULTING ENGINEERS  
(CIVIL, HYDRAULICS, SANITARY)

827 MAPLEDALE ROAD, ORANGE, CT 06477  
TEL: (203) 795-6562

FARMBROOK SITE 2B

Job \_\_\_\_\_  
Sheet Number D-8  
Date 7.22.1981  
By R.S./G.S.

INFLOW FLOOD HYDROGRAPH

TEST FLOOD (P.M.F.) = 6,000 CFS.  
DRAINAGE AREA = 2.63 SQ. MILES.

AS PER 'HYDROLOGY SECTION 4, SCS NATIONAL  
ENGINEERING HANDBOOK',

$$q_p = \frac{484 \cdot A \cdot Q}{T_p}$$

AND  $T_b = 2.67 \times T_p$

WHERE  $T_b$  = TIME BASE OF HYDROGRAPH IN HOURS  
 $T_p$  = TIME IN HOURS FROM START OF RISE  
OF HYDROGRAPH TO ATTAINMENT OF PEAK.  
 $q_p$  = PEAK RATE OF RUNOFF IN CFS.  
 $A$  = DRAINAGE AREA IN SQUARE MILES  
 $Q$  = TOTAL RUNOFF IN INCHES

SUBSTITUTING KNOWN VALUES OF  $A$ ,  $Q$  AND  $q_p$ :

$$6,000 = \frac{484 \times 2.63 \times 19}{T_p}$$

FROM WHICH  $T_p = 4$  HOURS

AND  $T_b = 2.67 \times 4 = 10.7$  HOURS  
SAY 11 HOURS

THE TRIANGULAR HYDROGRAPH ON THE  
FOLLOWING PAGE HAS BEEN DRAWN  
ACCORDINGLY.

SINGHAL ASSOCIATES

CONSULTING ENGINEERS  
(CIVIL, HYDRAULICS, SANITARY)

827 MAPLEDALE ROAD, ORANGE, CT 06477  
TEL: (203) 795-6562

Job FARMBROOK SITF2B  
Sheet Number D-9  
Date 8.31.1981  
By RSINGH

INFLOW HYDROGRAPH

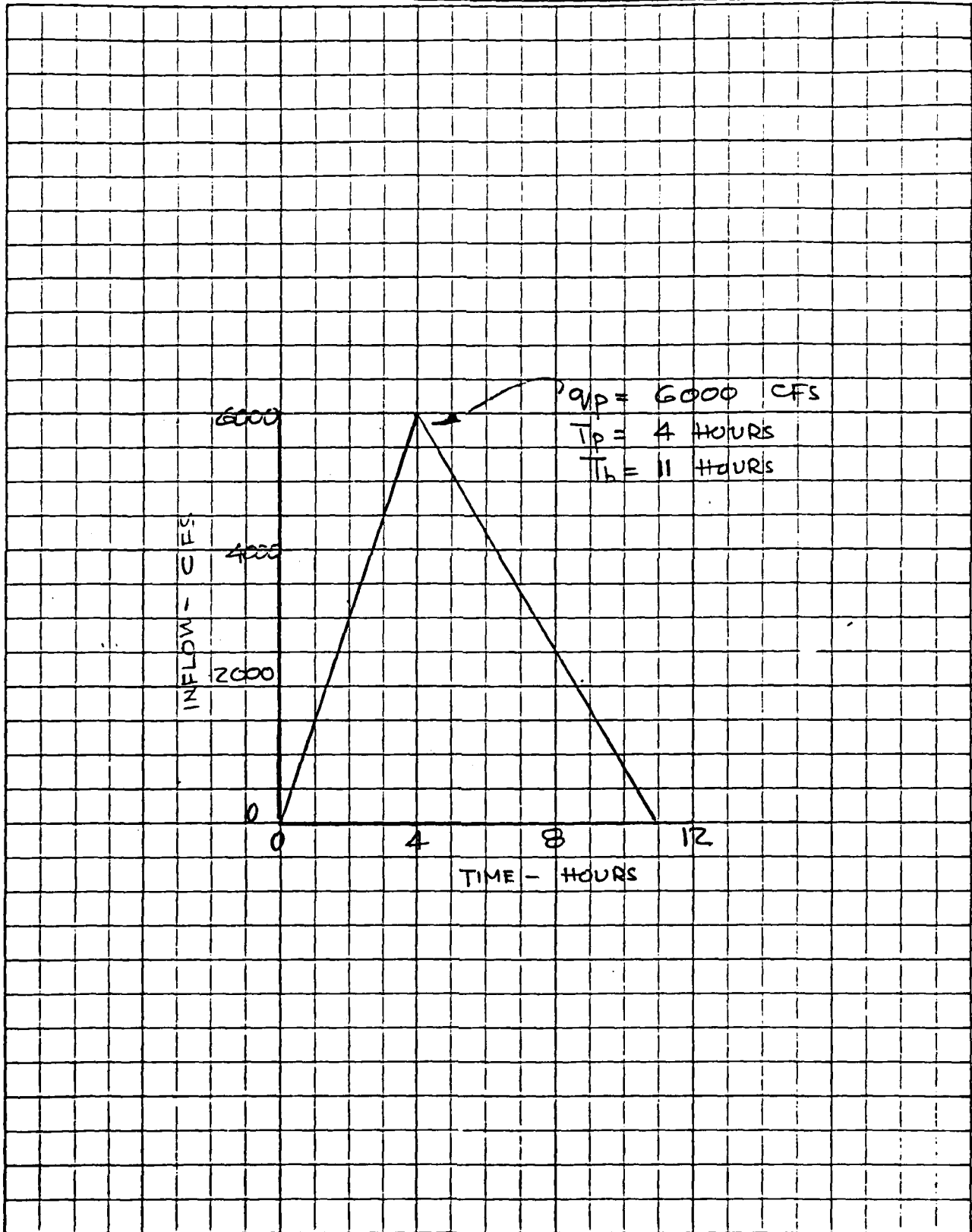

# SINGHAL ASSOCIATES

CONSULTING ENGINEERS  
(CIVIL, HYDRAULICS, SANITARY)

827 MAPLEDALE ROAD, ORANGE, CT 06477

TEL: (203) 795-6562

Job FARMBROOK SITE 2B

Sheet Number D-10

Date 03-31-1981

By R. SINGHAL

TIME (HRS)	ΔT (HRS)	AVERAGE INFLOW RATE (CFS)	AVERAGE INFLOW (AC.FT.)	TRIAL RESERVOIR ELEVATION AT END OF ΔT	RATE OF OUTFLOW (CFS)		OUTFLOW FOR ΔT (AC.FT.)	INCREMENTAL STORAGE ΔS (AC.FT.)	TOTAL STORAGE (AC.FT.)	RESERVOIR ELEVATION AT END OF ΔT
					END OF ΔT	AVG. FOR ΔT				
0										
1	1	750	63	96.6	200	160	8	55	55	97.21
2	1	2250	188	99.80	203	102	9	54	54	97.30
3	1	3750	313	103.65	215	209	17	171	225	99.8
4	1	5250	438	105.0	217	210	18	170	224	99.80
5	1	5570	464	105.40	1124	676	56	25	481	104.60
6	1	4715	393	103.65	2207	1212	101	212	436	103.63
7	1	3000	250	105.0	4910	3564	297	141	577	104.60
8	1	2140	178	105.40	5980	4095	342	96	532	105.40
9	1	1285	107	105.0	4920	5439	457	7	527	105.50
10	1	430	36	105.20	5426	5742	479	-15	515	105.20
11	1			105.00	4900	5173	431	-28	477	104.50
				104.80	4493	4960	413	-20	495	104.90
				104.50	3853	4173	348	-26	469	104.40
				104.00	2785	3319	277	-27	447	103.80
				103.90	2620	3236	270	-20	447	104.00
				103.50	1940	2290	191	-13	426	103.53
				103.55	2042	2331	194	-16	423	103.55
				103.00	1134	1588	132	-25	408	103.00
				102.50	685	909	76	-40	360	102.60
				102.20	411	772	64	-28	380	102.20

SINGHAL ASSOCIATES

CONSULTING ENGINEERS

(CIVIL, HYDRAULICS, SANITARY)

827 MAPLEDALE ROAD, ORANGE, CT 06477

TEL: (203) 795-6562

Job FARMBROOK SITE 2B

Sheet Number D-11

Date 8-31-1981

By R. SINGHA

INFLOW AND OUTFLOW HYDROGRAPHS

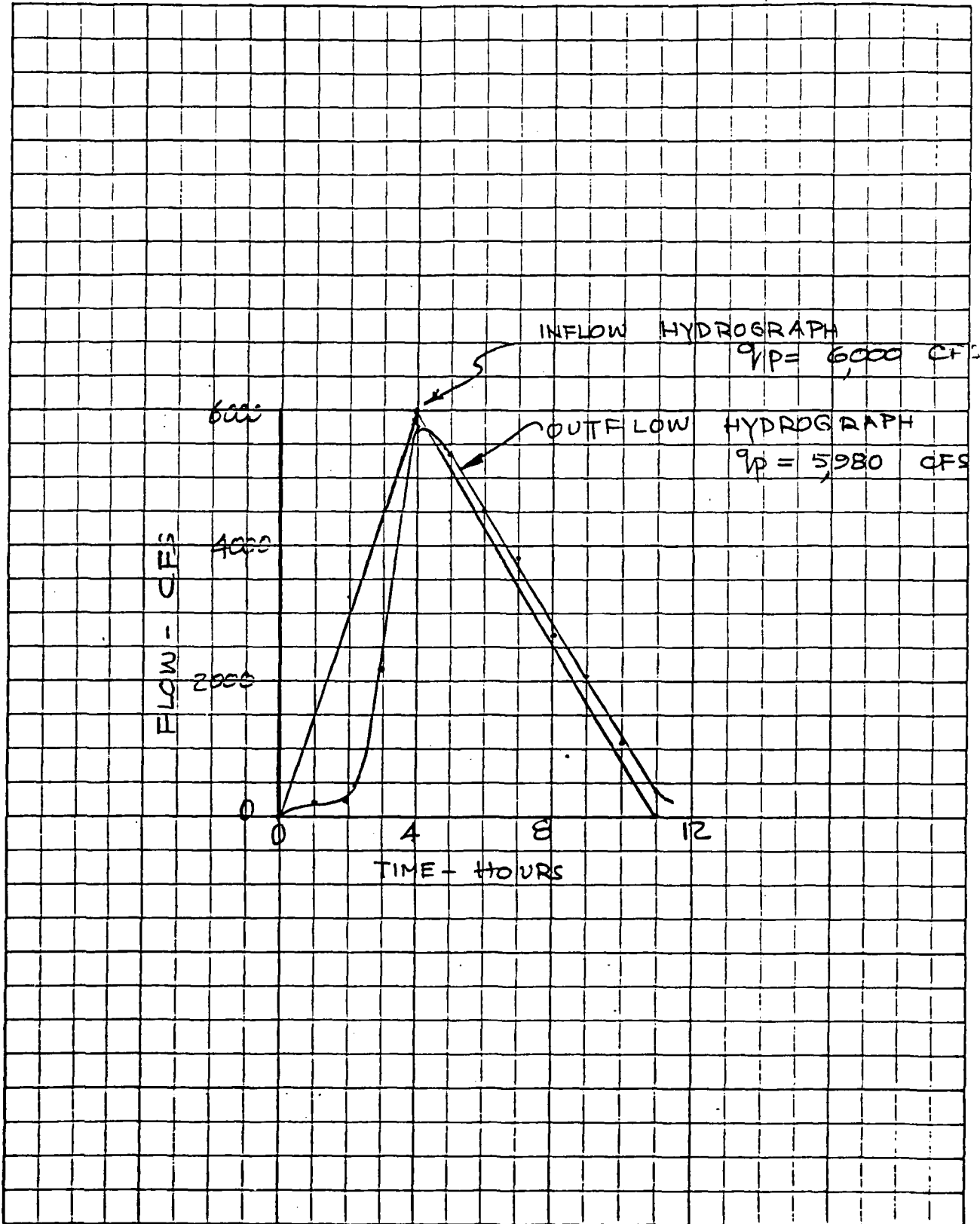

SINGHAL ASSOCIATES

CONSULTING ENGINEERS

(CIVIL, HYDRAULICS, SANITARY)

827 MAPLEDALE ROAD, ORANGE, CT 06477

TEL: (203) 795-6562

Job FARMBROOK SITE ZB DAM

Sheet Number D-12

Date 7-25-1981

By R.S.

DAM FAILURE FLOOD ROUTING

AS PER CORPS OF ENGINEERS' GUIDELINES:

$$Q_{p1} = \frac{8}{27} \cdot W_b \cdot \sqrt{2g} \cdot y_0^{3/2}$$

WHERE  $Q_{p1}$  = DAM FAILURE PEAK OUTFLOW IN CFS.

$W_b$  = BREACH WIDTH = 40% OF DAM LENGTH  
AT MID-HEIGHT

$y_0$  = HEIGHT FROM STREAM-BED TO  
POOL LEVEL AT FAILURE (103.8)

SUBSTITUTING THE VALUES OF  $W_b$  AND  $y_0$

AS  $(0.4 \times 1000')$  AND  $27'$ :

$$\begin{aligned} Q_{p1} &= \frac{8}{27} \cdot (0.4 \times 1000) \cdot \sqrt{32.2} \times 27^{3/2} \\ &= 79,351 \text{ CFS} \\ &\text{SAY } \underline{\underline{94,000 \text{ CFS}}} \end{aligned}$$

FARMBROOK SITE 218 DAM

X- SEC #1 STA 3+0  
(LOOKING D/S)

BROOK INV. 78.5

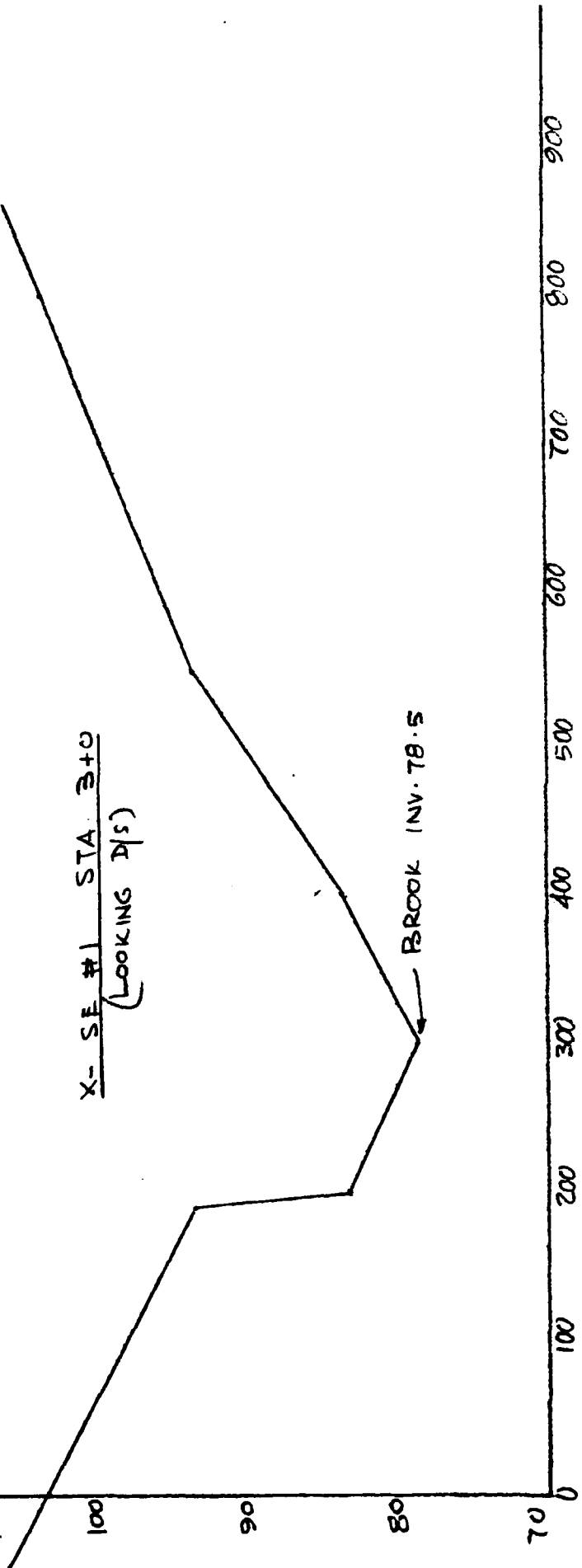

X- SEC #2 STA (3+50)  
(LOOKING D/S)

SWAMP

BROOK INV. 77.5

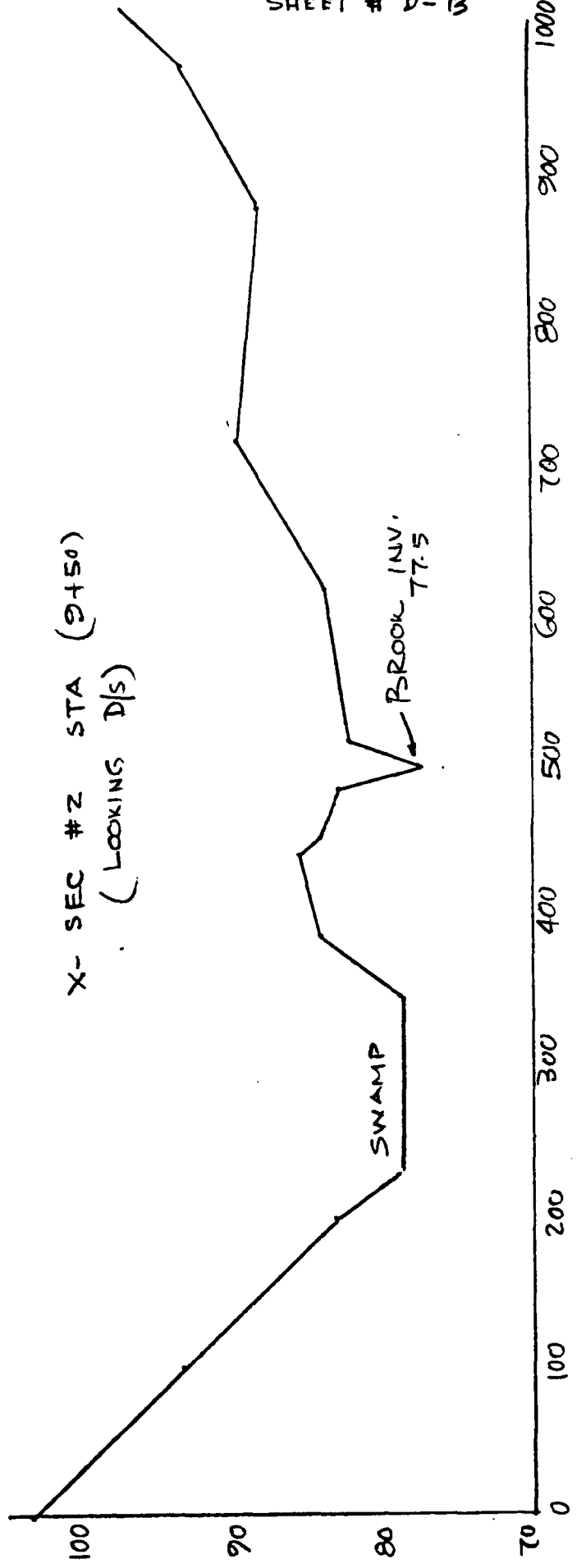





**SINGHAL ASSOCIATES****CONSULTING ENGINEERS  
(CIVIL, HYDRAULICS, SANITARY)**827 MAPLEDALE ROAD, ORANGE, CT 06477  
TEL: (203) 795-6562Job FARMBROOK SITE 2B DAMSheet Number D-16Date 7.26.1981By R.S.DAM FAILURE FLOOD ROUTING

X-SEC. #1 (STA. 3+0)

FOR  $Q_{P1} = 94,000$  CFS.,  $H_1 = 25.7'$  AND  $A_1 = 9,675$  SF.

REACH LENGTH = 300 FT.

STORAGE VOLUME =  $300 \times 9,675 / 43560 = 66.6$  AC. FT.  
= 0.47" OF RUNOFF

$$Q_{P2} = Q_{P1} \left(1 - \frac{0.47}{19}\right) = 94,000 \times 0.975 = 91,650 \text{ CFS.}$$

$$H_2 = 25.5' \quad \text{AND} \quad A_2 = 9,475 \text{ SF.}$$

$$\text{STORAGE} = 300 \times 9,475 / 43,560 = 65.2 \text{ AC. FT.}$$

$$\text{AVERAGE STORAGE} = \frac{1}{2} (66.6 + 65.2) = 65.9 \text{ AC. FT.}$$
  
= 0.47" OF RUNOFF

$$Q_{P3} = Q_{P1} \left(1 - \frac{0.47}{19}\right) = 94,000 \times 0.975 = 91,650 \text{ CFS}$$
  
SAY 92,000 CFS

THE ROUTED FLOW BELOW X-SEC. #1  
WILL BE = 92,000 CFS., AND  
 $H = 25.5$  FT.

POST-FAILURE FLOOD ELEVATION =  $78.5 + 25.5 = 104.0$

PRE-FAILURE FLOW =  $2370 \times \frac{90}{300} = 710$  CFS

FLOW-DEPTH = 3.5 FT.

AND FLOOD ELEV. =  $78.5 + 3.5 = 82.0$

RISE IN FLOOD STAGE =  $104.0 - 82.0 = 22.0$  FT

NUMBER OF HOUSES FLOODED :

BEFORE FAILURE = 0

AFTER FAILURE = 5

**SINGHAL ASSOCIATES**  
**CONSULTING ENGINEERS**  
(CIVIL, HYDRAULICS, SANITARY)

827 MAPLEDALE ROAD, ORANGE, CT 06477  
TEL: (203) 795-6562

Job FARMBROOK SITE 2B DAM  
Sheet Number D-17  
Date 7.26.1981  
By R.S.

DAM FAILURE FLOOD ROUTING

X-SEC #2 (STA. 9+50)

FOR  $Q_{p1} = 92,000$  CFS ,  $H_1 = 19.4'$  AND  $A_1 = 9940$  SF.

REACH LENGTH = 650 FT.

STORAGE VOLUME =  $650 \times 9940 / 43560 = 148.3$  AC-FT.  
= 1.06" OF RUNOFF

$Q_{p2} = Q_{p1} \left(1 - \frac{1.06}{19}\right) = 92,000 \times 0.944 = 88,700$  CFS

$H_2 = 19.0'$  AND  $A_2 = 9680$  SF.

STORAGE VOLUME =  $650 \times 9680 / 43560 = 144.4$  AC-FT.

AVERAGE STORAGE =  $\frac{1}{2} (148.3 + 144.4) = 146.4$  AC-FT  
= 1.04" OF RUNOFF

$Q_{p3} = Q_{p1} \left(1 - \frac{1.04}{19}\right) = 92,000 \times 0.945 = 87,000$  CFS

THE ROUTED FLOW BELOW X-SEC. #2 WILL BE  
87,000 CFS AND  $H = 19.0$  FT.

POST-FAILURE FLOOD ELEVATION =  $77.5 + 19.0 = 96.5'$

PRE FAILURE FLOW = 710 CFS.

FLOW DEPTH = 3.2 FT.

AND FLOOD ELEVATION =  $77.5 + 3.2 = 80.7$  SAY 81.0

RISE IN FLOOD STAGE =  $96.5 - 81.0 = 15.5'$

NUMBER OF HOUSES FLOODED :

BEFORE FAILURE = 0

AFTER FAILURE = 5

APPENDIX E

INFORMATION AS CONTAINED IN  
THE NATIONAL INVENTORY OF DAMS

NOT AVAILABLE AT THIS TIME

**END**

**FILMED**

**10-84**

**DTIC**