

MICROCOPY RESOLUTION TEST CHART
NATIONAL BUREAU OF STANDARDS-1963-A

1

CONNECTICUT COASTAL BASIN

WILTON, CONNECTICUT

SPECTACLE SWAMP DAM
CT 00476

PHASE I INSPECTION REPORT
NATIONAL DAM INSPECTION PROGRAM



DEPARTMENT OF THE ARMY
NEW ENGLAND DIVISION, CORPS OF ENGINEERS
WALTHAM, MASS. 02154

MAY 1981

DTIC
ELECTE

APR 21 1984

AD-A144 576

DTIC FILE COPY

This document is hereby approved
for distribution to the public
distribution is unlimited.

UNCLASSIFIED

SECURITY CLASSIFICATION OF THIS PAGE (When Data Entered)

REPORT DOCUMENTATION PAGE		READ INSTRUCTIONS BEFORE COMPLETING FORM	
1. REPORT NUMBER CT 00476	2. GOVT ACCESSION NO. A144576	3. RECIPIENT'S CATALOG NUMBER	
4. TITLE (and Subtitle) Spectacle Swamp Dam		5. TYPE OF REPORT & PERIOD COVERED INSPECTION REPORT	
NATIONAL PROGRAM FOR INSPECTION OF NON-FEDERAL DAMS		6. PERFORMING ORG. REPORT NUMBER	
7. AUTHOR(s) U.S. ARMY CORPS OF ENGINEERS NEW ENGLAND DIVISION		8. CONTRACT OR GRANT NUMBER(s)	
9. PERFORMING ORGANIZATION NAME AND ADDRESS		10. PROGRAM ELEMENT, PROJECT, TASK AREA & WORK UNIT NUMBERS	
11. CONTROLLING OFFICE NAME AND ADDRESS DEPT. OF THE ARMY, CORPS OF ENGINEERS NEW ENGLAND DIVISION, NEDED 424 TRAPELO ROAD, WALTHAM, MA. 02254		12. REPORT DATE May 1981	
14. MONITORING AGENCY NAME & ADDRESS (if different from Controlling Office)		13. NUMBER OF PAGES 70	
		15. SECURITY CLASS. (of this report) UNCLASSIFIED	
		15a. DECLASSIFICATION/DOWNGRADING SCHEDULE	
16. DISTRIBUTION STATEMENT (of this Report) APPROVAL FOR PUBLIC RELEASE: DISTRIBUTION UNLIMITED			
17. DISTRIBUTION STATEMENT (of the abstract entered in Block 20, if different from Report)			
18. SUPPLEMENTARY NOTES Cover program reads: Phase I Inspection Report, National Dam Inspection Program; however, the official title of the program is: National Program for Inspection of Non-Federal Dams; use cover date for date of report.			
19. KEY WORDS (Continue on reverse side if necessary and identify by block number) DAMS, INSPECTION, DAM SAFETY, Connecticut Coastal Basin Wilton, Connecticut			
20. ABSTRACT (Continue on reverse side if necessary and identify by block number) The 250 foot long, 21 foot high homogeneous earthfill embankment is 12 feet wide at the top and has 3:1 upstream and downstream slopes. The visual inspection of the dam indicated that the structure is in good condition. In accordance with the Corps of Engineers' Recommended Guidelines for Safety Inspection of Dams, the top of dam storage capacity (1,194 ac-ft) and the height of the dam (21 ft), the project is considered to be intermediate in size. The test flood will be equivalent to the PMF.			

REPRODUCED AT GOVERNMENT EXPENSE



DEPARTMENT OF THE ARMY
 NEW ENGLAND DIVISION, CORPS OF ENGINEERS
 424 TRAPELO ROAD
 WALTHAM, MASSACHUSETTS 02254

REPLY TO
 ATTENTION OF:

NEDED

JUL 14 1981

Honorable William A. O'Neill
 Governor of the State of Connecticut
 State Capitol
 Hartford, Connecticut 06115

Dear Governor O'Neill:

Inclosed is a copy of the Spectacle Swamp Dam (CT-00476) Phase I Inspection Report, prepared under the National Program for Inspection of Non-Federal Dams. This report is based upon a visual inspection, a review of the past performance and a brief hydrological study of the dam. I approve the report and support the findings and recommendations described in Section 7 and ask that you keep me informed of the actions taken to implement them. This follow-up action is vitally important.

Copies of this report have been forwarded to the Department of Environmental Protection. Copies will be available to the public in thirty days.

I wish to thank you and the Department of Environmental Protection for your cooperation in this program.

Sincerely,

C. E. EDGAR, III
 Colonel, Corps of Engineers
 Commander and Division Engineer

Incl
 As stated



Accession For	
NTIS GRA&I	<input checked="" type="checkbox"/>
DTIC TAB	<input type="checkbox"/>
Unannounced	<input type="checkbox"/>
Justification	
By _____	
Distribution/ _____	
Availability Codes	
Dist	Avail and/or Special
A-1	

SPECTACLE SWAMP DAM

CT 00476

CONNECTICUT COASTAL BASIN

WILTON, CONNECTICUT

PHASE I INSPECTION REPORT

NATIONAL DAM INSPECTION PROGRAM

NATIONAL DAM INSPECTION PROGRAM

PHASE I INSPECTION REPORT

Identification No: CT 00476
Name of Dam: Spectacle Swamp Dam
Town: Wilton
County and State: Fairfield, Connecticut
Stream: Spectacle Brook
Date of Inspection: December 10, 1980

BRIEF ASSESSMENT

The Spectacle Swamp Dam was designed by the U.S. Department of Agriculture Soil Conservation Service (SCS) and constructed by the Connecticut General Construction Company in 1973 to control flooding along Spectacle Brook, establish a wildlife preserve, and create a recreational pool. The 250-foot-long, 21-foot-high homogeneous earthfill embankment is 12 feet wide at the top and has 3:1 upstream and downstream slopes. Riprap has been provided on the upstream slope to an elevation 2 feet above the wildlife pool surface. The principal spillway is composed of a reinforced concrete drop inlet structure and a 30-inch-diameter conduit through the dam. The crest of the drop inlet riser is at elevation 577.0 NGVD and has a total crest length of 15 feet. There is an ungated low-level outlet on the upstream wall of the riser. This 1'-10" by 1'-4" outlet has an open intake which may be closed, using stoplogs, thus diverting the flow over the weirs on the sides of the intake. The rock cut emergency spillway on the right abutment is 15 feet wide and approximately 245 feet long with a crest elevation of 578.0.

The visual inspection of the dam indicated that the structure is in good condition. No indications of seepage through the dam were noted nor was seepage observed at the abutments or along the concrete spillway outlet pipe. There was no discharge from the 6-inch-diameter toe drain outlets during the inspection.

In accordance with the Corps of Engineers' Recommended Guidelines for Safety Inspection of Dams, the top of dam storage capacity (1,194 ac-ft) and the height of the dam (21 feet), the project is considered to be intermediate in size. In addition, the dam has been assigned a high hazard classification as a result of the potential for the loss of more than a few lives due to a breach of the dam. Consequently, the test flood will be equivalent to the Probable Maximum Flood (PMF). The resulting inflow to the pond is 2,300 cubic feet per second per square mile (cfs/sq. mi.) or 2,700 cubic feet per second (cfs). -The test flood outflow is approximately 1,240 cfs; and the combined capacity of the spillways, with the water surface at the top of the dam, is 1,600 cfs or 129 percent of the routed test flood outflow. Therefore, no overtopping of the dam is anticipated.

It is recommended that the owner retain a qualified registered professional engineer to perform an inspection of the dam during periods of high flow to evaluate the performance of the dam under design loads. In addition, an operation and maintenance manual and an emergency warning system should be developed.

The recommendations discussed in this section and in Section 7.2 should be instituted within two (2) years of the owner's receipt of this report, and the remedial measures presented in Section 7.3 should be implemented as indicated.

R. A. Hokenson, P.E.

R. A. Hokenson, P.E.
Project Manager
International Engineering Company, Inc.



This Phase I Inspection Report on Spectacle Swamp Dam has been reviewed by the undersigned Review Board members. In our opinion, the reported findings, conclusions, and recommendations are consistent with the Recommended Guidelines for Safety Inspection of Dams, and with good engineering judgement and practice, and is hereby submitted for approval.



ARAMAST MAHTESIAN, MEMBER
Geotechnical Engineering Branch
Engineering Division

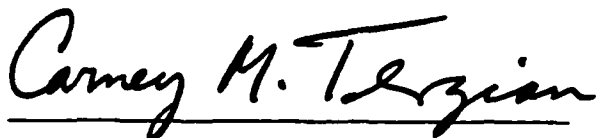

CARNEY M. TERZIAN, MEMBER
Design Branch
Engineering Division



JOSEPH W. FINEGAN, JR., CHAIRMAN
Water Control Branch
Engineering Division

APPROVAL RECOMMENDED:

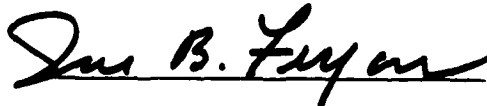

JOE B. FRYAR
Chief, Engineering Division

PREFACE

This report is prepared under guidance contained in the Recommended Guidelines for Safety Inspection of Dams, for Phase I Investigations. Copies of these guidelines may be obtained from the Office of Chief of Engineers, Washington, D.C. 20314. The purpose of a Phase I Investigation is to identify expeditiously those dams which may pose hazards to human life or property. The assessment of the general condition of the dam is based upon available data and visual inspection. Detailed investigation, and analyses involving topographic mapping, subsurface investigations, testing, and detailed computational evaluations are beyond the scope of a Phase I Investigation; however, the investigation is intended to identify any need for such studies.

In reviewing this report, it should be realized that the reported condition of the dam is based on observations of field conditions at the time of inspection along with data available to the inspection team. In cases where the reservoir was lowered or drained prior to inspection, such action, while improving the stability and safety of the dam, removes the normal load on the structure and may obscure certain conditions which might otherwise be detectable if inspected under the normal operating environment of the structure.

It is important to note that the condition of a dam depends on numerous and constantly changing internal and external conditions, and is evolutionary in nature. It would be incorrect to assume that the present condition of the dam would necessarily represent the condition of the dam at some point in the future. Only through continued care and inspection can there be any chance that unsafe conditions will be detected.

Phase I inspections are not intended to provide detailed hydrologic and hydraulic analyses. In accordance with the established Guidelines, the Spillway Test Flood is based on the estimated "Probable Maximum Flood" for the region (greatest reasonably possible storm runoff), or fractions thereof. Because of the magnitude and rarity of such a storm event, a

finding that a spillway will not pass the test flood should not be interpreted as necessarily posing a highly inadequate condition. The test flood provides a measure of relative spillway capacity and serves as an aid in determining the need for more detailed hydrologic and hydraulic studies, considering the size of the dam, its general condition and the downstream damage potential.

The Phase I Investigation does not include an assessment of the need for fences, gates, no-trespassing signs, repairs to existing fences and railings and other items which may be needed to minimize trespass and provide greater security for the facility and safety to the public. An evaluation of the project for compliance with OSHA rules and regulations is also excluded.

TABLE OF CONTENTS

<u>Section</u>	<u>Page</u>
Letter of Transmittal	
Brief Assessment	
Review Board Page	
Preface	i
Table of Contents	iii-v
Overview Photo	vi
Location Map	vii
REPORT	
1. PROJECT INFORMATION	1-1
1.1 General	1-1
a. Authority	1-1
b. Purpose of Inspection	1-1
c. Scope of Inspection Program	1-1
1.2 Description of Project	1-2
a. Location	1-2
b. Description of Dam and Appurtenances	1-2
c. Size Classification	1-3
d. Hazard Classification	1-4
e. Ownership	1-4
f. Operator	1-4
g. Purpose of Dam	1-4
h. Design and Construction History	1-4
i. Normal Operational Procedures	1-5
1.3 Pertinent Data	1-5
2. ENGINEERING DATA	2-1
2.1 Design Data	2-1
2.2 Construction Data	2-1
2.3 Operation Data	2-1
2.4 Evaluation of Data	2-1

<u>Section</u>	<u>Page</u>
3. VISUAL INSPECTION	3-1
3.1 Findings	3-1
a. General	3-1
b. Dam	3-1
c. Appurtenant Structures	3-2
d. Reservoir Area	3-3
e. Downstream Channel	3-3
3.2 Evaluation	3-3
4. OPERATIONAL AND MAINTENANCE PROCEDURES	4-1
4.1 Operational Procedures	4-1
a. General	4-1
b. Description of any Warning System in Effect	4-1
4.2 Maintenance Procedures	4-1
a. General	4-1
b. Operating Facilities	4-1
4.3 Evaluation	4-2
5. EVALUATION OF HYDRAULIC/HYDROLOGIC FEATURES	5-1
5.1 General	5-1
5.2 Design Data	5-1
5.3 Experience Data	5-1
5.4 Test Flood Analysis	5-1
5.5 Dam Failure Analysis	5-2
6. EVALUATION OF STRUCTURAL STABILITY	6-1
6.1 Visual Observation	6-1
6.2 Design and Construction Data	6-1
6.3 Post-Construction Changes	6-1
6.4 Seismic Stability	6-1

<u>Section</u>	<u>Page</u>
7. ASSESSMENT, RECOMMENDATIONS AND REMEDIAL MEASURES	7-1
7.1 Dam Assessment	7-1
a. Condition	7-1
b. Adequacy of Information	7-1
c. Urgency	7-1
7.2 Recommendations	7-1
7.3 Remedial Measures	7-2
a. Operation and Maintenance Procedures	7-2
7.4 Alternatives	7-3

APPENDIXES

APPENDIX A - INSPECTION CHECKLIST	A-1
APPENDIX B - ENGINEERING DATA	B-1
APPENDIX C - PHOTOGRAPHS	C-1
APPENDIX D - HYDROLOGIC AND HYDRAULIC COMPUTATIONS	D-1
APPENDIX E - INFORMATION AS CONTAINED IN THE NATIONAL INVENTORY OF DAMS	E-1

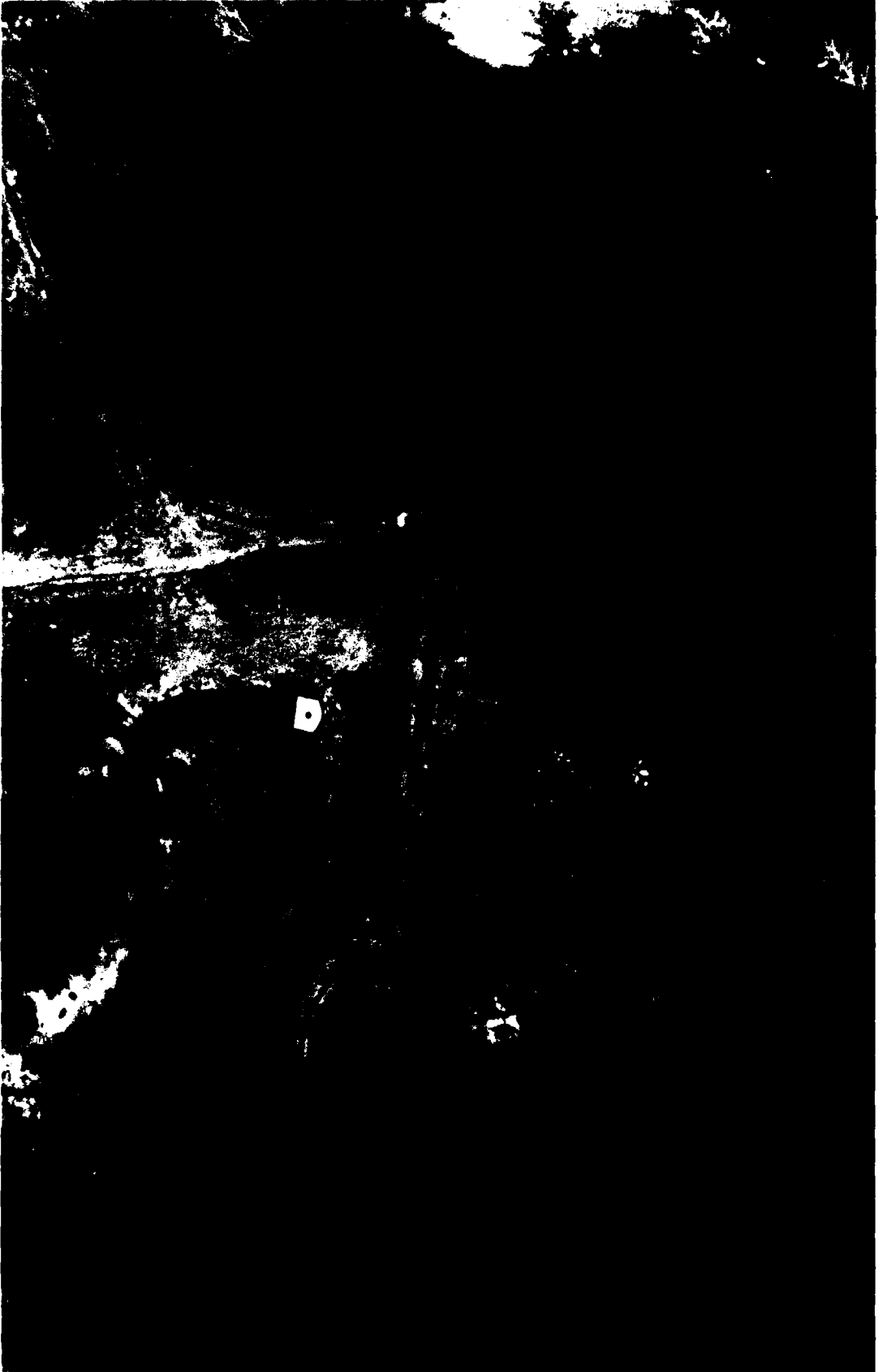

OVERVIEW PHOTO-SPECTACLE SWAMP DAM
FEBRUARY 24, 1981



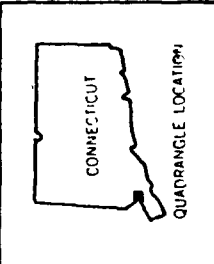
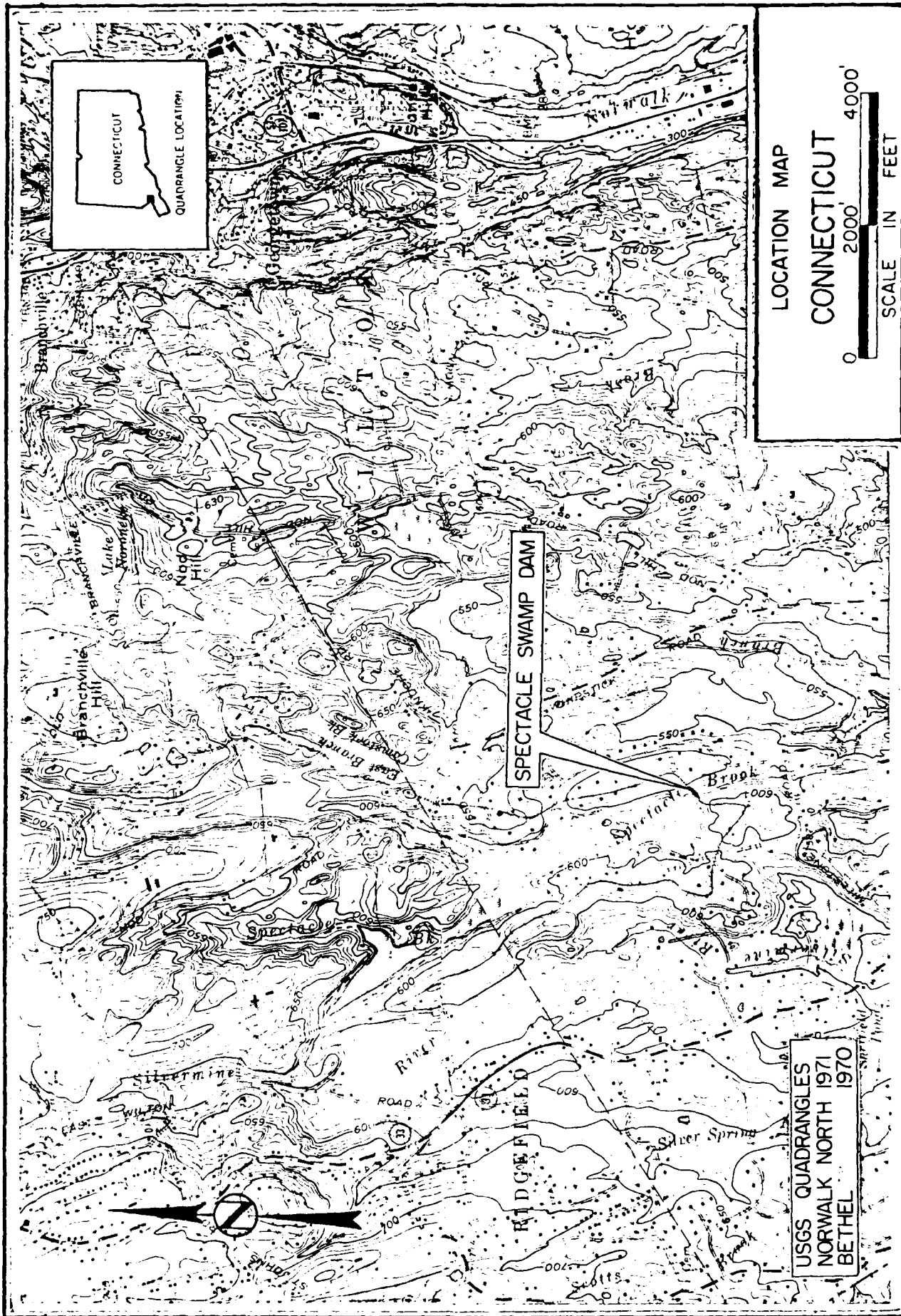

LOCATION MAP
CONNECTICUT
0 2000' 4000'
SCALE IN FEET

SPECTACLE SWAMP DAM

USGS QUADRANGLES
NORWALK NORTH 1971
BETHEL 1970

NATIONAL DAM INSPECTION PROGRAM

PHASE I INSPECTION REPORT

SPECTACLE SWAMP DAM

SECTION 1: PROJECT INFORMATION

1.1 GENERAL

a. Authority — Public Law 92-367, August 8, 1972, authorized the Secretary of the Army, through the Corps of Engineers, to initiate a National Program of Dam Inspections. The New England Division of the Corps of Engineers has been assigned the responsibility of supervising the inspection of dams within the New England Region. International Engineering Company, Inc., has been retained by the New England Division to inspect and report on selected dams in the State of Connecticut. Authorization and notice to proceed were issued to International Engineering Company in a letter dated November 5, 1980, from William E. Hodgson, Jr., Colonel, Corps of Engineers. Contract No. DACW33-81-C-0015 has been assigned by the Corps of Engineers for this work.

b. Purpose — The purposes of the program are to:

- (1) Perform technical inspection and evaluation of non-Federal dams to identify conditions which threaten the public safety and thus permit correction in a timely manner by non-Federal interests.
- (2) Encourage and prepare the states to initiate quickly effective dam safety programs for non-Federal dams.
- (3) Update, verify, and complete the National Inventory of Dams.

c. Scope of Inspection Program — The scope of this Phase I inspection report includes:

- (1) Gathering, reviewing, and presenting all available data as can be obtained from the owners, previous owners, the state, and other associated parties.
- (2) A field inspection of the facility detailing the visual condition of the dam, embankments, and appurtenant structures.
- (3) Computations concerning the hydraulics and hydrology of the facility and its relationship to the calculated flood through the existing spillway.
- (4) An assessment of the condition of the facility and corrective measures required.

1.2 DESCRIPTION OF PROJECT

a. Location - Spectacle Swamp Dam is located on Spectacle Brook in the northwest portion of the Town of Wilton, Fairfield County, Connecticut, approximately 1 mile from the confluence with the east branch of Comstock Brook. The location of the dam is defined by the coordinates latitude $N41^{\circ}14.4'$ and longitude $W73^{\circ}28.3'$ on the North Norwalk, Connecticut, USGS Quadrangle map.

b. Description of the Dam and Appurtenances - The dam consists of a 250-foot-long homogeneous earthfill embankment, a concrete principal spillway, and an emergency spillway cut into rock at the right abutment (see Appendix B, Sheet B-1). The dam is 12 feet wide at the top, rises to a height of 21 feet above the streambed, which corresponds to elevation 585.5 NGVD, and has a maximum potential storage of 1,194 acre-feet. (Note: All elevations are referenced to the National Geodetic Vertical Datum.) The upstream and downstream faces are inclined on 3:1 slopes. Riprap protection has been provided to an elevation of 572 on the upstream slope and around the outlet conduit on the downstream slope.

The principal spillway is located at the midsection of the embankment. The reinforced concrete intake structure is comprised of two uncontrolled inlets. The low-level intake protrudes from the upstream face of the riser and has two side weirs, which constitute a total crest length of 8 feet. The crest elevation of these weirs is 570. There are slots for stoplogs on the open upstream end of the structure. Flow from the intake is diverted through a 1'-10" by 1'-4" opening in the upstream wall of the riser. The riser forms a 2'-6" by 7'-6" drop inlet with a total crest length of 15 feet at elevation 577. Both intakes are protected by steel trashracks. A 30-inch-diameter concrete conduit extends 148 feet from the intake structure to the downstream slope of the dam. Discharge from the conduit is directed toward a small riprap-lined stilling basin in the natural streambed.

A trench drain under the downstream toe of the dam is used with 6-inch perforated pipes to collect seepage through the dam and the underlying foundation material. The two drain pipe outlets are located on opposite sides of the principal spillway conduit at an invert elevation of 565.0.

The 245-foot-long emergency spillway has a 15-foot-wide crest length, 1:1 and 3:1 side slopes, and is cut in rock adjacent to the right abutment. The crest is defined by a level concrete slab on the floor of the spillway channel at elevation 578.

A plan of the site and cross sections of the dam have been provided in Appendix B. Photographs of the facility are presented in Appendix C.

c. Size Classification - INTERMEDIATE - The classification for size is based on the height of the dam above the natural streambed or the maximum storage potential measured which may be considered as the storage resulting from the water surface elevation within the impoundment being equal to the elevation of the top of the dam. The size of the dam is

determined by either storage or height depending on which criteria yields the larger size category. The dam has a maximum potential storage capacity of 1,194 ac-ft and the top of the structure is approximately 21 feet above the natural streambed. Consequently, the dam may be classified as INTERMEDIATE in size, since the storage capacity is within the limits of the intermediate size category (1,000 ac-ft to 50,000 ac-ft).

d. Hazard Classification - HIGH - The hazard classification is based on the estimated loss of life and the anticipated property damage due to a dam breach when the water surface within the impoundment is at the top of the dam. The failure of Spectacle Swamp Dam would flood the first downstream home to a depth of 7 feet, the second home to 5 feet and two additional homes would experience 1 to 3 feet of flooding. In addition, it is anticipated that the prefailure outflow would cause approximately 2 feet of flooding at the first downstream home. Consequently, the dam breach would damage four homes and the bridge culvert at Millstone Road and could potentially cause the loss of more than a few lives. Therefore, the dam has been classified as having a HIGH hazard potential.

e. Ownership - Department of Environmental Protection
State of Connecticut
165 Capital Avenue
State Office Building
Hartford, Connecticut 06115

f. Operator - Steven Lozyniak
Department of Environmental Protection
(203) 226-6983

g. Purpose of Dam - Recreation, flood control, and to create a wildlife preserve.

h. Design and Construction History - The dam was designed by the U.S. Department of Agriculture Soil Conservation Service and constructed by the Connecticut General Construction Company. Since the dam's completion in 1973, there have been only minor changes to the low-level intake structure.

i. Normal Operational Procedures - Under normal conditions, the flow through the principal spillway is uncontrolled. As a result, the normal pool elevation corresponds to the crest elevation of the low-level intake. An acute vandalism problem at the site requires that the low-level intake be cleared of debris on a weekly basis in the summer and twice a week in the winter. Mowing of grass on the embankment has been discontinued so as to provide a natural deterrent to trespassers. A more extensive discussion of the maintenance procedures currently employed at the site is presented in Section 4.

1.3 PERTINENT DATA

a. Drainage Area - The drainage area consists of approximately 1.16 square miles of rolling wooded terrain. The surface area of the reservoir is normally 35 acres (water surface El. 570.0) and is largely swampy.

b. Discharge at the Dam Site - Discharges from the impoundment are conducted by means of the uncontrolled low-level outlet on the upstream face of the riser, over the crest of the riser, and through the emergency spillway. At the time of the inspection, discharge through the principal spillway outlet conduit was estimated to be 5 cfs.

- (1) Principal Spillway Outlet Works
Inlet Size: 1'-10" by 1'-4" at invert elevation 567.
Conduit Size: 30" with invert elevation 566 at downstream end.
- (2) Maximum known flood at dam site could not be determined, since there are no flow or gage records maintained for Spectacle Brook.
- (3) Ungated principal spillway capacity is 105 cfs with the water surface at the top of the dam (elevation 585.5).
- (4) Ungated emergency spillway capacity is 1,495 cfs at the top of the dam (elevation 585.5).

- (5) Ungated principal spillway capacity at test flood elevation (584.5) is 105 cfs.
- (6) Ungated emergency spillway capacity at test flood elevation (584.5) is 1,135 cfs.
- (7) Gated spillway capacity at normal pool elevation - N/A
- (8) Gated spillway capacity at test flood elevation - N/A
- (9) Total spillway capacity at test flood elevation (584.5) is 1,238 cfs.
- (10) Total project discharge at top of dam is 1,600 cfs at elevation 585.5.
- (11) Total project discharge at test flood elevation (584.5) is 1,240 cfs.

c. Elevation (feet above NGVD)

(1) Streambed at toe of dam	564.5
(2) Bottom of cutoff	560.0
(3) Maximum tailwater	Unknown
(4) Normal pool (recreation)	570.0
(5) Flood-control pool	578.0
(6) Principal spillway crest	577.0
(7) Emergency spillway crest	578.0
(8) Design surcharge (original design)	583.4
(9) Top of dam	585.5
(10) Test flood surcharge	584.5

d. Reservoir (length in feet)

(1) Normal pool (recreation)	4,600
(2) Flood-control pool	6,550
(3) Principal spillway crest pool	6,500
(4) Emergency spillway crest pool	6,550
(5) Top of dam	6,700
(6) Test flood pool	6,600

e. Storage (acre-feet)

(1) Normal pool	34
(2) Flood-control pool	500
(3) Principal spillway crest pool	420
(4) Emergency spillway crest pool	500
(5) Top of dam	1,194
(6) Test flood pool	1,025

f. Reservoir Surface (acres)

(1) Normal pool	35
(2) Flood-control pool	77
(3) Principal spillway crest pool	73
(4) Emergency spillway crest pool	77
(5) Test flood pool	103
(6) Top of dam	109

g. Dam

(1) Type	Earthfill embankment
(2) Length	250 ft
(3) Height	21 ft
(4) Top Width	12 ft
(5) Side Slopes	3 H to 1 V (upstream and downstream)
(6) Zoning	Homogeneous
(7) Impervious Core	None
(8) Cutoff	3-foot-deep cutoff trench
(9) Grout Curtain	None
(10) Other	Drain trench with 6-inch pipes along dam toe

h. Diversion and Regulating Tunnel N/A

i. Spillways

Principal Spillway

(1) Type	Concrete drop inlet
(2) Length of weir	2 by 7.5 ft
(3) Crest elevation	577.0
(4) Gates	N/A
(5) U/S Channel	Length: 18 ft; Width: 5 ft; Slopes: 2:1 to 3:1
(6) D/S Channel	Length: 65 ft; Width: 1.5 ft to 10 ft; Slopes: 2:1 to 3:1
(7) General	30-inch-diameter and 148-foot-long concrete conduit from spillway riser; trashracks on riser intake.

Emergency Spillway

(1) Type	Unlined overflow channel
(2) Length of weir	15 ft
(3) Crest elevation	578.0
(4) Gates	N/A
(5) U/S Channel	Length: 70 ft; Slopes: 1:1 to 3:1
(6) D/S Channel	Length: 145 ft; Slopes: 1:1 to 3:1
(7) General	30-foot-long concreted crest

j. Regulating Outlets: Low-level opening in upstream riser wall

(1) Invert	567.0
(2) Size	1'-10"(H) by 1'-4"(W)
(3) Description	Concrete opening
(4) Control Mechanism	None
(5) Other	Trashracks and slots for stoplogs

SECTION 2: ENGINEERING DATA

2.1 DESIGN DATA

The design calculations and drawings were obtained from the U.S. Department of Agriculture Soil Conservation Service and the State of Connecticut Water Resource Department, respectively. The design calculations contained the hydraulics of the principal and emergency spillways and geology investigation results.

2.2 CONSTRUCTION DATA

- a. Available Data - "As-built" drawings are on file at the U.S. Department of Agriculture Soil Conservation Service, Storrs, Connecticut.
- b. Construction Considerations - The dam was built according to the design drawings.

2.3 OPERATION DATA

Maintenance of the facility includes removing trees and clearing debris. The embankment slopes are not mowed so as to provide a deterrent to trespassers. The site is frequently visited by a State of Connecticut Department of Environmental Protection (DEP) representative to remove debris from the low-level intake. No written operation and maintenance manual has been prepared for this facility, however, an operations and maintenance agreement was signed by the owner (DEP) with the designer, the U.S. Department of Agriculture Soil Conservation Service (SCS). This agreement contains the requirements for annual inspections and items to be checked for possible maintenance needs.

2.4 EVALUATION OF DATA

- a. Availability - Data was provided by the designer (U.S. Department of Agriculture Soil Conservation Service) and the State of Connecticut Water Resource Department. In addition, a representative was sent on behalf of the owner, the State of Connecticut DEP, to discuss the operation and history of the dam.

b. Adequacy - Detailed hydrologic/hydraulic data was available and was used to perform computations to determine the spillway capacity. The final assessment of the dam was based primarily on the visual inspection, past performance, and spillway capacity computations.

c. Validity - Based on a visual inspection of the dam, the external features of the dam are in substantial agreement with those shown on the record drawings.

SECTION 3: VISUAL INSPECTION

3.1 FINDINGS

a. General - The field inspection of Spectacle Swamp Dam was conducted on December 10, 1980. At the time of the inspection, water was flowing over the low-level intake crest and the reservoir surface elevation was approximately 570.1. The embankment and appurtenances were in good condition.

b. Dam - The dam is a homogeneous earthfill embankment with a concrete drop inlet spillway at the central part of the embankment and an emergency spillway crest cut into the rock near the right abutment. No sloughing or erosion of the embankment were noted.

- (1) Top - The top of the dam is primarily grass covered with the exception of a narrow footpath extending the length of the dam (Photo 1).
- (2) Upstream Slope - The upstream slope is largely covered with grass except for a layer of riprap extending 2 feet above the water surface. The protective riprap layer was unevenly distributed with outcrops of weeds and grass observed over much of the protected area (Photo 2). Inspection of the embankment was hampered by the heavy growth of vegetation on the slope; however, several small burrows ranging from 2 to 3 inches in diameter were noted in the vicinity of the right abutment. A large, but shallow hole, approximately 8 inches in diameter, was observed on the right bank of the principal spillway approach channel near the intersection of the bank and the upstream slope of the dam. The larger hole is apparently an abandoned burrow.
- (3) Downstream Slope - The downstream slope is, for the most part, covered by grass with the exception of the area surrounding the principal spillway outlet (Photos 4 and 8). No

significant amounts of riprap were missing or displaced in this area, but grass and weeds were observed growing between the stones. The toe drains were not operational during the inspection and the right toe drain outlet was partially obstructed by soil (Photos 5 and 6). Displacement of the riprap was most prevalent around the right toe drain outlet where a small portion of the subgrade was exposed. Several small burrows, approximately 2 to 3 inches in diameter, were observed beneath the heavy ground cover in the vicinity of the right abutment. No evidence of seepage was found at the downstream toe of the dam or around the spillway outlet conduit.

c. Appurtenant Structures - The principal spillway riser is in relatively good condition with only slight superficial cracks on top of the concrete structure. The trashracks on the low-level drain showed signs of superficial rust, while the principal spillway trashracks were free of corrosion. The low-level drain was operational despite the accumulation of debris in the intake (Photo 3). The exposed portion of the concrete outlet conduit appeared to be sound with no observable cracks or leaks.

The outlet channel is generally clear with the exception of the vegetation growing between the riprap on the channel side slopes (Photo 4). The channel cross section was uniform and showed no signs of significant slope deterioration (Photo 8).

The earthen portions of the emergency spillway side slopes have been subject to erosion and the displaced soil has been deposited at the bottom of the emergency spillway. Fallen boulders from the fissured rock outcrops that comprise the remainder of the spillway side slopes were also noted within the spillway (Photo 7). The emergency spillway crest was strewn with the remains of a campfire, but the concrete appeared to be sound with no visible cracking or spalling. In addition, wooded areas adjacent to the entrance and outlet of the emergency spillway, which could obstruct flow through the structure, were noted (Photos 8 and 9).

d. Reservoir Area - The area surrounding the reservoir is largely wooded and lightly developed. The reservoir was formed with the intent of creating a wildlife preserve; and as a result, the impoundment is a shallow marshy region covering approximately 35 acres.

e. Downstream Channel - The downstream channel follows the natural bed of Spectacle Brook. The channel has a bottom width of approximately 8 feet and 3:1 side slopes that rise 3 feet above the channel bottom. There are essentially three constrictions in the channel. These structures include a small bridge supporting a driveway 700 feet from the dam, the Millstone Road bridge culvert 1,000 feet downstream, and another private driveway bridge 450 feet from the Millstone culvert. The first downstream constriction is a 40-foot-long driveway spanning Spectacle Brook above two 3-foot-diameter culverts. At Millstone Road, a 3-foot-high and 5-foot-wide horseshoe-shaped bridge culvert channels the brook beneath the road surface. The final constriction within the impact area is a 3.5-foot-diameter culvert supporting a driveway on Hickory Hill Road. The terrain within the impact area may be described as rolling, wooded, and residential.

3.2 EVALUATION

Based on the visual inspection of Spectacle Swamp Dam, it has been determined that the structure is in generally good condition. The following features, which could influence the condition and/or stability of the dam in the future, were identified:

- (1) The debris in the low-level drain intake could impair discharge from the concrete outlet conduit. In addition, large quantities of abrasive debris passing through the outlet could severely damage the concrete conduit.
- (2) Animal burrows and deeply rooted vegetation could increase seepage through the embankment.

- (3) Unstable rock on the emergency spillway side slopes could serve to obstruct the drainage of the channel. Also, the discharge of large quantities of debris from the site will increase the downstream damage during a flood.
- (4) The wooded upstream and downstream areas adjacent to the emergency spillway could disrupt flow through the spillway and add a significant quantity of debris to the discharge.
- (5) The trees and other growth within the reservoir area could obstruct both the principal and emergency spillways during periods of high flow.

SECTION 4: OPERATIONAL AND MAINTENANCE PROCEDURES

4.1 OPERATIONAL PROCEDURES

a. General - The facility was designed to control flooding within the Spectacle Brook watershed; consequently, there are no regularly scheduled regulatory procedures.

b. Description of any Warning System in Effect - There is no formal written downstream warning system in effect at Spectacle Swamp Dam.

4.2 MAINTENANCE PROCEDURES

a. General - The facility is visually inspected annually by a state dam inspector, a regional representative, and a representative from the Soil Conservation Service. Upon completion of the inspection, a report is submitted to the State of Connecticut Water Resource Department (Appendix B). However, there is no formal maintenance program to implement the inspection team's recommendations. In addition, it has become necessary to check the low-level outlet every two weeks and weekly during school holidays to stay abreast of the vandalism at the site. The growth of ground cover on the embankment is no longer controlled, since it provides an effective deterrent to trespassers.

b. Operating Facilities - Debris is cleared from the low-level intake and outlet conduit during visits by the maintenance crew. In addition, the trashracks covering the low-level drain are continuously renovated and upgraded.

4.3 EVALUATION

The operation and maintenance procedures currently employed at the dam are fair. Some of these procedures are justified in light of the acute vandalism problem; however, there are some areas requiring improvement. Maintenance of the site should be scheduled regularly, periodic inspections conducted, and records documenting the operation of the facility should be kept for future reference. In addition, a formal written downstream warning system and emergency operation guidelines should be established. Remedial measures and maintenance recommendations are presented in Section 7.

SECTION 5: EVALUATION OF HYDRAULIC/HYDROLOGIC FEATURES

5.1 GENERAL

The dam was constructed to impound water for flood control purposes. The concrete drop inlet principal spillway and unlined rock cut emergency spillway are fairly large with respect to the 1.16 sq. mi. watershed. These structures will pass 129 percent of the project test flood outflow without overtopping the dam.

The dam and appurtenant structures appear to be sound. The principal spillway, spillway channel, and emergency spillway have no substantial obstructions; however, rocks were observed in the intake structure of the principal spillway and on the crest of the emergency spillway.

5.2 DESIGN DATA

Design data was obtained from the design drawings and a report by the U.S. Department of Agriculture Soil Conservation Service (SCS) entitled "Norwalk Watershed Project", 1972. The principal spillway routing was performed using a 100-year frequency, 10-day duration storm, while the emergency spillway routing was performed using a 100-year, 6-hour storm (see Appendix B).

5.3 EXPERIENCE DATA

No information concerning serious problem situations arising at the dam were found, and it does not appear that the dam has been overtopped.

5.4 TEST FLOOD ANALYSIS

The maximum potential storage capacity of Spectacle Swamp Dam (1,194 ac-ft) satisfies the criteria for the intermediate size category; and the hazard classification for the dam is high, since more than a few lives could be lost in the event of a dam breach. Therefore, the

recommended test flood for this dam is equivalent to the Probable Maximum Flood (PMF). The peak test flood inflow to the reservoir for a 1.16 sq. mi. rolling watershed is 2,300 cfs/sq. mi. or 2,700 cfs. The inflow due to the test flood (2,700 cfs) and the resulting outflow (1,240 cfs) will cause the water surface elevation within the impoundment to rise to El. 584.5, or 1.0 foot below the top of the dam. The combined capacity of the emergency and principal spillways is 1,600 cfs with the pond water surface at the top of the dam, or 129 percent of the routed peak test flood outflow. In the test flood analysis it was assumed that the low-level outlet would be plugged and, as a result, the test flood surcharge was measured from the principal spillway crest (El. 577.0).

5.5 DAM FAILURE ANALYSIS

Utilizing the "Rule of the Thumb Guidance for Estimating Downstream Dam Failure Hydrographs", dated April 1978, the failure outflow was calculated to be 9,040 cfs with the water surface, within the impoundment, at the top of the dam, since the PMF did not overtop the dam, the dam breach analysis was also evaluated using the test flood water surface elevation. These calculations did not yield a significant reduction in the stage within the impact area and, therefore, did not affect the hazard classification.

The breach width was approximately 43.6 feet and included the principal spillway. However, since this structure and the dam will not fail concurrently, the discharge from this outlet was included in the failure outflow. The failure of Spectacle Swamp Dam will cause the water surface within the downstream channel to rise from 4.8 feet at a prefailure outflow of 1,600 cfs to 9.6 feet at a failure outflow of 9,040 cfs. The failure of Spectacle Swamp Dam would flood the first downstream home to a depth of 7 feet, the second home to 5 feet and two additional homes would experience 1 to 3 feet of flooding. In addition, it is anticipated that the prefailure outflow would cause approximately 2 feet of flooding at the first downstream home. As a result, the breach of the dam would damage four homes and the bridge culvert at Millstone Road and could potentially cause the loss of more than a few lives. Therefore, the dam has been classified as having a HIGH hazard potential.

SECTION 6: EVALUATION OF STRUCTURAL STABILITY

6.1 VISUAL OBSERVATION

The visual inspection did not reveal any indications of stability problems. There are some areas of deterioration, as described in Section 3; however, they are not considered stability concerns at the present time.

6.2 DESIGN AND CONSTRUCTION DATA

The available design drawings and data listed in Appendix B were insufficient to perform an in-depth stability analysis of the dam. The following criteria were established based on the findings of the soil boring program performed during the design phase.

- (1) "Foundation seepage should not be excessive" and "the overall transmissibility will be low." "The small amount of seepage and resulting uplift pressures can be adequately controlled by a trench drain." "In conjunction with the drain, a shallow cutoff trench should be installed."
- (2) "No unusual consolidation problems are anticipated" in foundation material of the principal spillway.
- (3) "The dam is planned as a homogeneous fill to consist of SM material." As-built drawings were prepared and are available at the Soil Conservation Service office in Storrs, Connecticut.

6.3 POST-CONSTRUCTION CHANGES

There are no indications of any post-construction changes of the dam with exception of minor changes made to the low-level intake gate.

6.4 SEISMIC STABILITY

The dam is in Seismic Zone 1 and, in accordance with the Recommended Guidelines, does not warrant seismic analysis.

SECTION 7: ASSESSMENT, RECOMMENDATIONS AND REMEDIAL MEASURES

7.1 DAM ASSESSMENT

a. Condition - Based upon the visual inspection of the site and past performance, the dam appears to be in good condition. No evidence of structural instability was observed in the dam, principal spillway, or appurtenant structures. The earthfill embankment is in generally good condition. There are, however, areas of some concern which require maintenance and monitoring.

Based upon "Rule of Thumb Guidance for Estimating Downstream Dam Failure Hydrograph", dated April 1978, and hydraulic/hydrologic computations, the peak inflow to the reservoir at the test flood is 2,700 cfs and peak outflow is 1,240 cfs. These flows will not result in the overtopping of the dam. The hydraulic computations yield a spillway capacity of 1,600 cfs, which is equivalent to approximately 129 percent of the routed test flood outflow.

b. Adequacy of Information - The information available is such that an assessment of the condition and stability of the dam must be based solely on visual inspection, past performance, and sound engineering judgement.

c. Urgency - It is recommended that the measures presented in Section 7.2 be implemented within two (2) years of the owner's receipt of this report and that the measures presented in Section 7.3 be implemented as indicated.

7.2 RECOMMENDATIONS

It is recommended that further inspections be made by a registered professional engineer qualified in dam design and inspection. Subsequent inspections of the dam should be conducted during periods of

high project discharges to evaluate the condition of the dam under design loads. Special attention should be given to the functional condition of the toe drain system and the ability of the dam to withstand seepage at high stages, especially in the vicinity of the principal spillway conduit, at the abutments, and along the toe of the dam. In addition, the following should be instituted:

- (1) Institute a program of annual technical inspection by a qualified registered professional engineer. This program should be thoroughly documented to provide accurate records for future reference.
- (2) Investigate alternate designs for the low-level outlet so as to alleviate the accumulation of debris in this structure. This new design should allow the structure to remain operative without frequent maintenance.

7.3 REMEDIAL MEASURES

a. Operation and Maintenance Procedures — The following measures should be instituted immediately upon the owner's receipt of this report:

- (1) Animal burrows on the upstream and downstream slopes should be filled with a suitable compacted material and protective growth established to prevent erosion.
- (2) The accumulation of soil in the right toe drain should be removed to ensure the proper drainage of the dam.
- (3) Loose rocks on the slopes of the emergency spillway, fallen boulders in the spillway, and the rocks on the concrete spillway crest should be removed.
- (4) Rocks and wooden debris in the low-level intake should be removed to prevent plugging this outlet.

The following measures should be instituted within two years of the owner's receipt of this report:

- (1) The displaced riprap on the downstream slope of the embankment in the vicinity of the right toe drain outlet should be repaired.
- (2) The growth of vegetation on the dam embankment and within and along the side slopes of the emergency spillway should be controlled to avoid damage due to root infiltration, yet maintain an effective barrier to trespassers.
- (3) The wooded areas adjacent to the emergency spillway intake and outlet should be cleared to ensure unrestricted flow through the structure during periods of high project discharge.
- (4) The rusted areas of the trashracks on the low-level intake should be cleaned and painted.
- (5) Develop an "Emergency Action Plan" that will include an effective preplanned downstream warning system; locations of emergency equipment, materials, and manpower; authorities to contact; and potential areas that require evacuation.

7.4 ALTERNATIVES

This study has identified no practical alternative to the above recommendations.

APPENDIX A

VISUAL CHECK LIST WITH COMMENTS

VISUAL INSPECTION CHECK LIST

PARTY ORGANIZATION

PROJECT: Spectacle Swamp Dam

DATE: 12/10/80

TIME: 1:30 p.m.

WEATHER: Overcast, 38°F

W.S. ELEV.: 570.1

PARTY:

INITIALS:

1. Carol H. Cunningham	CC
2. Miron B. Petrovsky	MP
3. Ernst H. Ruggisch	EB

<u>PROJECT FEATURE</u>	<u>INSPECTED BY</u>
1. Embankment	CC, EB
2. Principal Spillway:	
Intake	MP, EB
Outlet	MP, EB
3. Emergency Spillway	CC, MP
4. Outlet Channel	CC, MP, EB

PERIODIC INSPECTION CHECK LIST

PROJECT: Spectacle Swamp Dam

DATE: 12/10/80

PROJECT FEATURE: Embankment

NAME: CC, EB

AREA EVALUATED	CONDITION
<u>DAM EMBANKMENT:</u>	
Crest Elevation	585.5
Current Pool Elevation	570.1
Maximum Impoundment to Date	Unknown
Surface Cracks	None Visible
Pavement Condition	N/A
Movement or Settlement of Crest	None Apparent
Lateral Movement	None Apparent
Vertical Alignment	Good
Horizontal Alignment	Good
Condition at Abutment and at Concrete Structures	Good, no seepage along outlet conduit.
Indications of Movement of Structural Items on Slopes	None
Trespassing on Slopes	Small animal burrows on upstream and downstream slopes. Trails along crest and faces of dam.
Sloughing or Erosion of Slopes or Abutments	None
Rock Slope Protection - Riprap Failures	None, riprap subject to disturbance by vandals.
Unusual Movement or Cracking at or near Toes	None
Unusual Embankment or Downstream Seepage	None
Piping or Boils	None
Foundation Drainage Features	Operation of drains could not be observed, no flow.
Toe Drains	Right toe drain outlet partially clogged.
Instrumentation System	None

PERIODIC INSPECTION CHECK LIST

PROJECT: Spectacle Swamp Dam

DATE: 12/10/80

PROJECT FEATURE: Principal Spillway Intake

NAME: MP, EB

AREA EVALUATED	CONDITION
<p><u>OUTLET WORKS - INTAKE CHANNEL AND INTAKE STRUCTURE</u></p>	
<p>a. Approach Channel</p> <p>Slope Conditions</p> <p>Bottom Conditions</p> <p>Rock Slides or Falls</p> <p>Trashracks</p> <p>Debris</p> <p>Condition of Concrete Lining</p> <p>Drains or Weep Holes</p>	<p>Grass covered</p> <p>Rocky (placed riprap)</p> <p>None</p> <p>Low stage crest screen in good condition</p> <p>Rocks and wood in low-level intake</p> <p>N/A</p> <p>N/A</p>
<p>b. Intake Structure</p> <p>Condition of Concrete</p> <p>Stop Logs and Slots</p>	<p>Slight cracking on top of intake structure</p> <p>Inoperable</p> <p>Note: Local kids plug up low-level outlet to cause water level to rise for swimming in the summer and skating in the winter. This is accomplished by throwing rocks into the low-level outlet and covering it with cardboard.</p>

PERIODIC INSPECTION CHECK LIST

PROJECT: Spectacle Swamp Dam

DATE: 12/10/80

PROJECT FEATURE: Emergency Spillway (Continued)

NAME: CC, MP

AREA EVALUATED	CONDITION
<u>OUTLET WORKS - SERVICE BRIDGE</u>	
a. Super Structure Bearings Anchor Bolts Bridge Seat Longitudinal Members Under Side of Deck Secondary Bracing Deck Drainage System Railings Expansion Joints Paint	N/A
b. Abutment & Piers General Condition of Concrete Alignment of Abutment Approach to Bridge Condition of Seat & Backwall	N/A

PERIODIC INSPECTION CHECK LIST

PROJECT: Spectacle Swamp Dam

DATE: 12/10/80

PROJECT FEATURE: Principal Spillway Outlet

NAME: MP, EB

AREA EVALUATED	CONDITION
<u>OUTLET WORKS - TRANSITION AND CONDUIT</u>	
General Condition of Concrete	Good
Rust or Staining on Concrete	None
Spalling	None
Erosion or Cavitation	None
Cracking	None Visible
Alignment of Monoliths	The majority of the conduit was in the embankment and was inaccessible. Therefore, the number and condition of all of the joints could not be properly assessed. However, the joints that were visible appeared to be sound.
Alignment of Joints	
Numbering of Monoliths	

PERIODIC INSPECTION CHECK LIST

PROJECT: Spectacle Swamp Dam

DATE: 12/10/80

PROJECT FEATURE: Outlet Channel

NAME: CC, MP, EB

AREA EVALUATED	CONDITION
<p><u>OUTLET WORKS - OUTLET STRUCTURE AND OUTLET CHANNEL</u></p> <p>General Condition of Concrete</p> <p>Rust or Staining</p> <p>Spalling</p> <p>Erosion or Cavitation</p> <p>Visible Reinforcing</p> <p>Any Seepage or Efflorescence</p> <p>Condition at Joints</p> <p>Drain Holes</p> <p>Channel</p> <p>Loose Rock or Trees Overhanging Channel</p> <p>Condition of Discharge Channel</p>	<p>N/A</p> <p>Rocks in channel near conduit. Trees and bushes along entire downstream channel.</p> <p>Fair, adjacent to outlet conduit. Small trees and brush are growing through the riprap slope protection in this area. The condition of the channel varies as it passes through the wooded downstream area.</p>

PERIODIC INSPECTION CHECK LIST

PROJECT: Spectacle Swamp Dam

DATE: 12/10/80

PROJECT FEATURE: Emergency Spillway

NAME: CC, MP

AREA EVALUATED	CONDITION
<p><u>OUTLET WORKS - SPILLWAY WEIR, APPROACH AND DISCHARGE CHANNELS</u></p>	
<p>a. Spillway Channel</p> <p>General Condition</p> <p>Loose Rock Overhanging Channel</p> <p>Trees Overhanging Channel</p> <p>Floor of Approach Channel</p>	<p>Fair</p> <p>Deterioration of side slopes - possibly due to vandalism. Wooded area at spillway intake.</p> <p>Small trees, shrubs and grass growing out of side walls.</p> <p>Some debris</p>
<p>b. Weir and Training Walls</p> <p>General Condition of Concrete</p> <p>Rust or Staining</p> <p>Spalling</p> <p>Any Visible Reinforcing</p> <p>Any Seepage or Efflorescence</p> <p>Drain Holes</p>	<p>Grass covered earth weir in good condition</p> <p>The concreted crest section in the channel bottom is in good condition. The remainder of the channel is unlined.</p> <p>N/A</p> <p>N/A</p> <p>N/A</p> <p>N/A</p> <p>N/A</p>
<p>c. Discharge Channel</p> <p>General Condition</p> <p>Loose Rock Overhanging Channel</p> <p>Trees Overhanging Channel</p> <p>Floor of Channel</p> <p>Other Obstructions</p>	<p>Fair</p> <p>None</p> <p>Channel passes through a wooded area before intersecting Spectacle Brook.</p> <p>Some debris.</p>

PERIODIC INSPECTION CHECK LIST

PROJECT: Spectacle Swamp Dam

DATE: 12/10/80

PROJECT FEATURE: Principal Spillway Intake
(Continued)

NAME: MP, EB

AREA EVALUATED	CONDITION
<p><u>OUTLET WORKS - CONTROL TOWER</u></p> <p>a. Concrete and Structural</p> <p>General Condition</p> <p>Condition of Joints</p> <p>Spalling</p> <p>Visible Reinforcing</p> <p>Rusting or Staining of Concrete</p> <p>Any Seepage or Efflorescence</p> <p>Joint Alignment</p> <p>Unusual Seepage or Leaks in Gate Chamber</p> <p>Cracks</p> <p>Rusting or Corrosion of Steel</p> <p>b. Mechanical and Electrical</p> <p>Air Vents</p> <p>Float Wells</p> <p>Crane Hoist</p> <p>Elevator</p> <p>Hydraulic System</p> <p>Service gates</p> <p>Emergency Gates</p> <p>Lighting Protection System</p> <p>Emergency Power System</p> <p>Wiring and Lighting System</p>	<p>N/A</p> <p>N/A</p>

APPENDIX B

ENGINEERING DATA

SUMMARY OF DATA AND CORRESPONDENCE

<u>DATE</u>	<u>TO</u>	<u>FROM</u>	<u>SUBJECT</u>	<u>PAGE</u>
3/81			Plan, Profile and Sections	B-2
---		Connecticut DEP	Water Resource Inventory Data Sheet	B-3
8/23/79		Connecticut DEP	Water Resource Operation and Maintenance Inspection Report	B-4
1968		USDA Soil Conservation Service	Excerpts from Spectacle Swamp Design Report	B-5

REPRODUCED AT GOVERNMENT EXPENSE

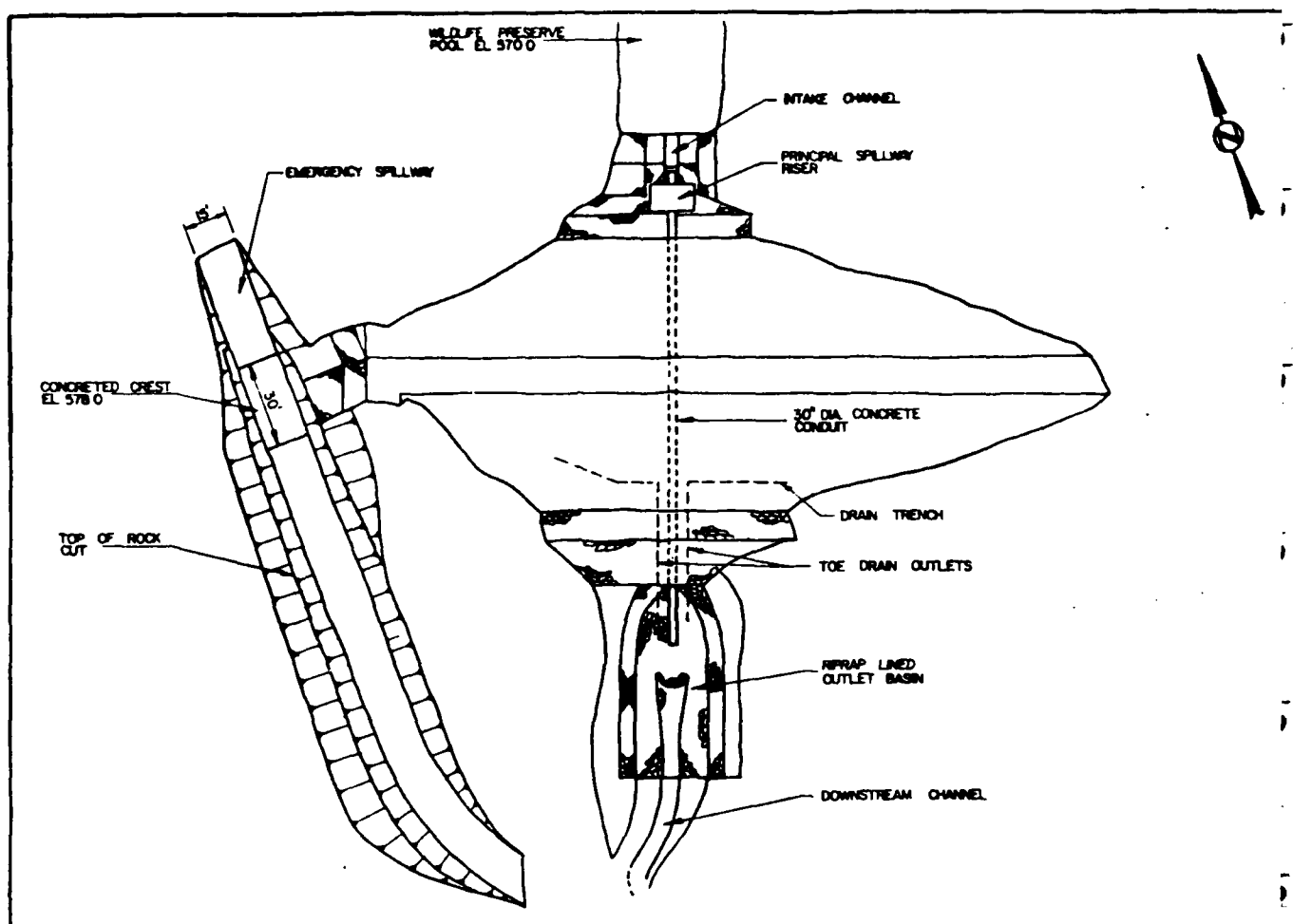

PLAN

0 30' 60'

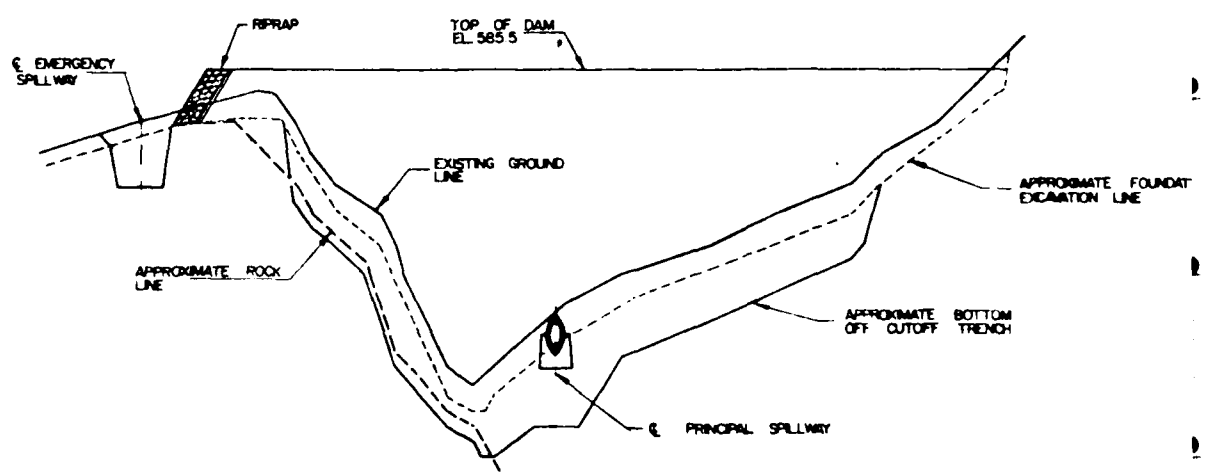

PROFILE ALONG C OF DAM

HORIZONTAL SCALE : 0 30' 60'

VERTICAL SCALE : 0 60' 120'

WHEEL
 PILLARY

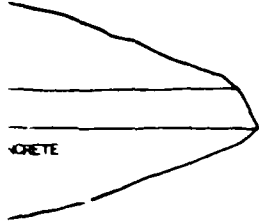

TRENCH
 OUTLETS
 GOVERNMENT EXPENSE
 WIND BASIN
 BEAM CHANNEL

BE PRODUCED BY

REPRODUCED BY

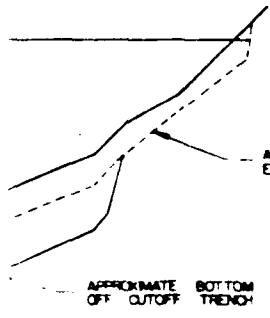

SPILLWAY

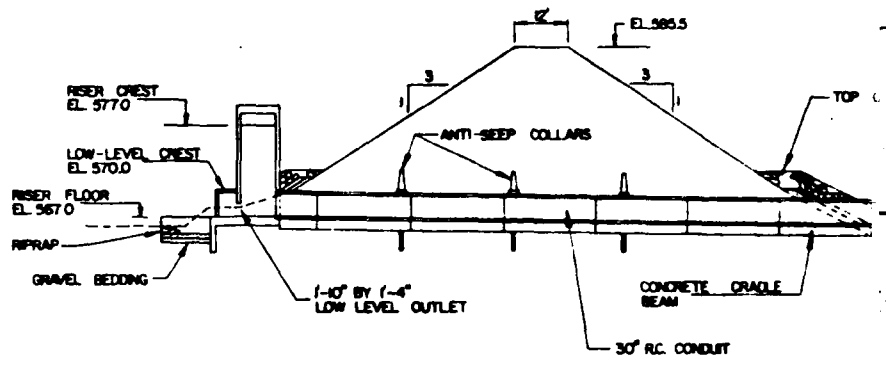

PRINCIPAL SPILLWAY SECTION

HORIZONTAL SCALE:
 VERTICAL SCALE:

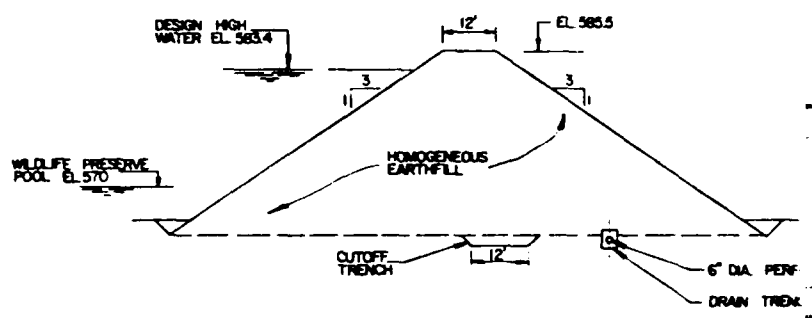

TYPICAL DAM SECTION

NOT TO SCALE

NOTE:
 THIS PLAN WAS COMPILED BY THE DEPARTMENT OF CONSTRUCTION SERVICE (1971) AND SUBMITTED BY ENGINEERS.

INTERNATIONAL ENGINEER DANIEL, CONNOR & ASSOCIATES ENGINEER	
NATIONAL PROGRAM PLAN SP	
SPECTACLE BROOK	
DESIGNED BY	CHECKED BY
<i>[Signature]</i>	<i>[Signature]</i>

REPRODUCED AT GOVERNMENT EXPENSE

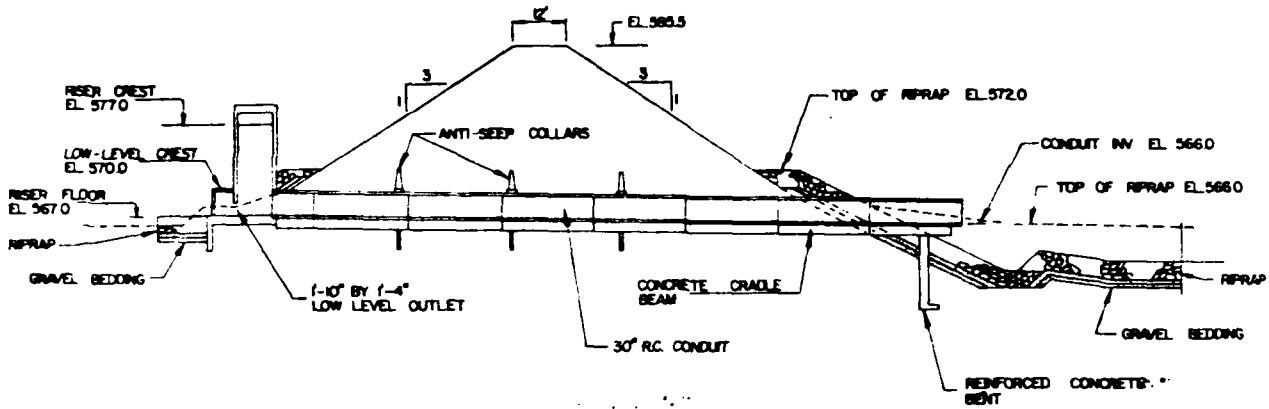

PRINCIPAL SPILLWAY SECTION

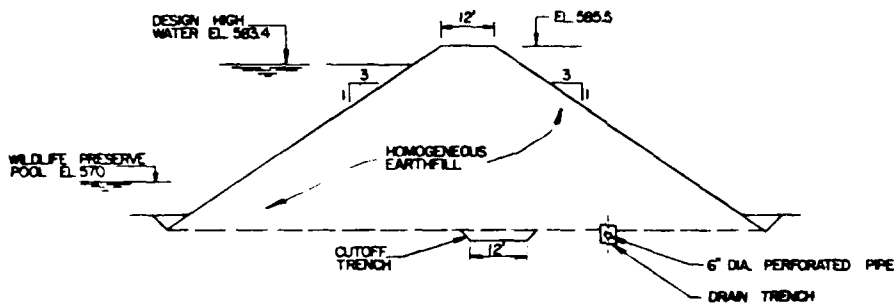
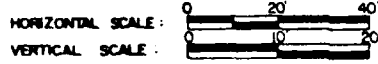

TYPICAL DAM SECTION
NOT TO SCALE

NOTE :

THIS PLAN WAS COMPILED FROM THE ORIGINAL DESIGN DRAWINGS PREPARED BY THE DEPARTMENT OF AGRICULTURE SOIL CONSERVATION SERVICE (1971) AND SUPPLEMENTARY FIELD OBSERVATIONS MADE BY ECO ENGINEERS.

INTERNATIONAL ENGINEERING CO DARIEN, CONNECTICUT ENGINEER	U.S. ARMY ENGINEER DISTRICT NEW ENGLAND CORPS OF ENGINEERS WALTHAM, MASS
NATIONAL PROGRAM OF INSPECTION OF NON-FEDERAL DAMS	
PLAN, PROFILE AND SECTIONS	
SPECTACLE SWAMP DAM	
SPECTACLE BROOK WILTON, CONNECTICUT	
DESIGNED BY	CHECKED BY
APPROVED BY	SCALE AS NOTED
DATE MARCH 1981	SHEET B-1

Inventoried
By _____

Date _____

9
CT 47
Site 7

Name of Dam or Pond SPECTACLE Swamp DAM

Code No. W9

Nearest Street Location MILLSTONE ROAD

Town WILTON

U.S.G.S. Quad. NORWALK NORTH LAT 41° 19.4'

Name of Stream SPECTACLE BROOK LONG 73° 28.3'

Owner State SCS.

Address _____

Pond Used For _____ DA 1.165M3

Dimensions of Pond: Width _____ Length _____ Area 77

Total Length of Dam 250 Length of Spillway 30'

Location of Spillway WEST END

Height of Pond Above Stream Bed 20'

Height of Embankment Above Spillway 2'

Type of Spillway Construction EARTH 1 DROP INLET

Type of Dike Construction "

Downstream Conditions _____

Summary of File Data _____

Remarks _____

Would Failure Cause Damage? _____ Class _____

1973

REPRODUCTION AT GOVERNMENT EXPENSE

WATER RESOURCES UNIT - D.E.P.
OPERATION AND MAINTENANCE INSPECTION REPORT

PROJECT: Wilton - Spectacle Brook

DATE: August 23, 1979

INSPECTION PARTY: D. Thompson, Soil Conservation Service, S. Lozyniak and V. Galgowski, Department of Environmental Protection

ITEM	CONDITION S or U*	MAINTENANCE OR REPAIRS REQUIRED	DATE COMPLETED
I. Embankments			
A. Vegetation	S	Cut brush	
B. Rip rap	S		
C. Drains	S		
II. Principal Spillway			
A. Trash rack	S		
B. Gates	N/A		
C. Stilling Basin	S		
D. Conduit	S		
III. Emergency Spillway			
A. Vegetation	S		
B. Obstructions	S		
IV. Outlet Channels			
A. Slope protection	S	Cut brush	
B. Debris	S		
V. Reservoir Area			
A. Debris	S		
B. Stop logs	S		
VI. Miscellaneous			
A. Access road	S		
B. Fences	N/A		

Remarks: Placing additional wood chips on access has limited motorbike traffic.

IECO Eastern District			
JAN 17 '81			
C-			
To	A		
1/17/81	RAH		3
1/22/81	SFC		3
1/23/81			

Inspected by: Victor F. Galgowski

Title Supt. of Dam Maintenance

- * S = Satisfactory
- U = Unsatisfactory
- N/A = Not applicable

ENGINEERING REPORT

✓
E-2
a-1

NORWALK RIVER WATERSHED

SITE NO. 7B - SPECTACLE BROOK

Location: Wilton, Connecticut

Class of Structure: C

Drainage Area: 1.16 square miles

Maximum Height of Dam: 19 Feet

Length of Dam: 230 Feet

Volume of Fill: 4800 cubic yards

Floodwater Storage: 80 Acre-Feet

Fish and Wildlife Storage: 34 Acre-Feet

Prepared by:

Wm. H. Leeming, Jr.
William H. Leeming, Jr.
Design Engineer
Storrs, Connecticut

Concurred by:

W. T. Ferguson, Jr.
Whitney T. Ferguson, Jr.
State Conservation Engineer
Storrs, Connecticut

April 12, 1971

U. S. DEPARTMENT OF AGRICULTURE
SOIL CONSERVATION SERVICE

DRAWING NO. CN-435

SHEET 1 4

ENGINEERING REPORT

FOUNDATION

The foundation materials underlying the 1.5' to 2' thick surficial soil have more than adequate strength to support the relatively low fill proposed. Removal of the surficial material thru foundation preparation will result with minimal foundation settlements due generally to the small magnitude of the applied load and the nature of the unconsolidated (relative) foundation material. Also, as the unconsolidated foundation materials increase in thickness the applied load decreases.

Under the low head proposed, foundation seepage should not be excessive. Based mainly upon the soil descriptions and secondarily (due to difficulty of sealing the casing, etc.) upon field permeability test results, the overall transmissibility will be low. As noted in the geology report, the high value of permeability obtained in hole 2A must be viewed with bias.

Some seepage will undoubtedly occur thru the areas of fractured bedrock. However, the bedrock to which water will have the easiest access (right abutment) is some of the least fractured material. The most severely fractured material exists in the vicinity of the principal spillway. Here it is overlain by about 15' of low-to moderately permeable soil thus restricting seepage into the fractured zone and inducing significant head loss.

The small amount of seepage and resulting uplift pressures can be adequately controlled by a trench drain. On the right abutment the trench drain should completely penetrate the overlying unconsolidated soil and extend into the consolidated material as methods for common excavation will permit (1' to 2' max). Here the drain should extend up the abutment to about the elevation of the emergency spillway crest. Over the remaining portion of the foundation the drain should extend about 3' to 4' below the foundation line and extend up the left abutment to elevation 570-575.

In conjunction with the drain, a shallow cutoff trench should be installed. It should extend up the entire right abutment and penetrate to or into (about 1') the underlying consolidated material. It should extend up the left abutment to about elevation 575-580 and penetrate to a depth of about 3' to 4'.

PRINCIPAL SPILLWAY

The principal spillway foundation is generally an SM material with scattered boulders. The delineated surface of the underlying bedrock varies by about 5' in elevation over the length of the spillway, the bedrock surface being higher at the downstream end. The rock surface is lowest at the centerline of dam and rises slightly toward the upstream end. This configuration is reasonably compatible with the distribution of the applied embankment load. No unusual consolidation problems are anticipated.

EMBANKMENT

The dam will have a 12' top width with 3:1 side slopes. Riprap will be provided on the upstream slope to an elevation (to be determined) above the proposed wildlife pool elevation. Due to the shallowness of the pool and the configuration of the pool near the dam, a berm is not warranted. The dam is planned as a homogeneous fill to consist of SM material.

EMERGENCY SPILLWAY

The emergency spillway is planned for the right abutment at about elevation 577. As it appears that essentially no useable borrow material will be available from this excavation, the final width must be based upon a cost comparison of embankment volume and emergency spillway excavation. The variability of the condition of the rock thru which the spillway will be excavated is well documented by the logs of the borings. However, it does appear that the rock within the bed of the exit channel will be reasonably sound. The excavated rock surface will undoubtedly be quite erratic due to the natural fracturing. Consideration will be given to over-excavating the bed of the inlet and exit channels to permit placement of sufficient (8" - 12") topsoil for establishing vegetative cover. The topsoil will help prevent deterioration of the rock surface due to puddling and freezing of water. Exit channel velocities should still be based upon a rock cross section (if entire depth of flow is within rock) and should be maintained less than 15 feet per second.

BORROW

All borrow for the dam will be obtained from the proposed borrow area which is about 400' upstream of the dam. It

ENGINEERING REPORT



appears that an adequate amount of material is available above the ground water level. Based upon the backhoe test pits, an average of about 15 percent cobbles and boulders will be encountered in the fill materials. This will probably necessitate the use of a rock rake in the borrow area.

The topography of the area lends itself to maintaining both surface drainage and erosion control measures.

DISPOSAL AREAS

The borrow area will provide a site for disposal of unuseable excavated materials.

U S DEPARTMENT OF AGRICULTURE
SOIL CONSERVATION SERVICE

DRAWING NO CN-435

SHEET 4 OF 4

State _____ Project _____
 By _____ Date _____ Checked By _____ Date _____ Job No. _____
 Subject **WORK PLAN - DESIGN COMPARISON** Sheet _____ of _____

ITEM	UNIT	WORK PLAN	DESIGN	COMMENTS
<u>DRAINAGE AREA</u>	SQ. MI.	1.16	1.16	
<u>STORAGE CAPACITY</u>				
SEDIMENT (INC. AERATED)	AC. FT.	6	6	
BENEFICIAL	AC. FT.	62	20	VALUES BASED ON ELEV. 570.0
RETARDING	AC. FT.	437	472	
TOTAL	AC. FT.	505	498	
BETWEEN HIGH & LOW S.	AC. FT.			
<u>SURFACE AREA</u>				
NORMAL POOL	ACRE	34	35.5	
RETARDING POOL	ACRE	90.	77.5	
DESIGN HIGH WATER	ACRE		100	
<u>VOLUME OF FILL</u>	CU. YD.	3,000	1,000	CHANGE DUE TO NEW EMER. SPILLWAY
<u>TOP OF DAM ELEV</u>	FEET	582.7	585.5	EM. SPILLWAY CHANGE
<u>MAX. HEIGHT OF DAM</u>	FEET	19	21	
<u>EMERGENCY SPILLWAY</u>				
CREST ELEVATION	FEET	577.7	578.0	CHANGES BASED ON GEOLOGIC INVESTIGATION
BOTTOM WIDTH	FEET	113	15	
TYPE	-	VEGETATED	ROCK	
PERCENT CHANCE OF USE	-	1	1	
AVE. CURVE NO. COND. II	-	74	88	15" MINOR & 16.5" MAJOR STATE CRITERIA
<u>EM. SP. HYDROGRAPH</u>				
STORM RAINFALL - 6 HR.	IN.	18.68	16.50	STATE CRITERIA
STORM RUNOFF	IN.	14.42	15.00	BASED SCS. 6 HR. STORM
VELOCITY OF FLOW - V _c	FPS	7.5	9.46	VEGETATED TO ROCK EM. SPILLWAY
PEAK DISCHARGE RATE	CFS	1490	1662	EMER. SPILLWAY
MAX. WATER SURFACE EL.	FEET	580.7	583.36	CHANGES
<u>FREEBOARD HYDROGRAPH</u>				
STORM RAINFALL - 6 HR.	IN.	25.50	25.00	
STORM RUNOFF	IN.	21.72	21.23	
VELOCITY OF FLOW - V _c	FPS	8.7	10.7	
PEAK DISCHARGE RATE	CFS	2305	992	EMER. SPILLWAY CHANGE
MAX. WATER SURFACE EL.	FEET	581.7	584.89	
<u>PRINCIPAL SPILLWAY</u>				
RISER SIZE	FT.			
MAX. LOW STAGE FLOW	CFS	34	33	
ORIFICE SIZE	FT.		1'-10" x 1'-4"	
MAX. HIGH STAGE FLOW	CFS		74	PIEKER CREST 577.0
PIPE SIZE	DIA.	30"	30"	
<u>CAPACITY EQUIVALENTS</u>				
TOTAL SEDIMENT VOL.	IN.	0.10	0.10	
RETARDING STORAGE	IN.	7.36	7.62	
EM. SPILLWAY STORAGE TO TOP OF DAM	IN.	7.19	11.28	TOP OF DAM HIGHER
<u>CLASS OF STRUCTURE</u>	-	C	C	
<u>CONSTRUCTION COSTS</u>	-			
<u>B-C RATIO</u>	-			

SD-100 (REV. 11-15-61)

SUBJECT	SHEET
STAGE - STORAGE	1
STAGE - DISCHARGE (PRIN. SPWY)	3
TAIL WATER (PRIN. SPWY)	7
STORM ROUTING (PRIN. SPWY - 24 hr)	8
STORM ROUTING (PRIN. SPWY - 10 day)	9
STORM ROUTING SUMMARY	12
STAGE - DISCHARGE (EMER. SPWY)	13
DRAW DOWN	16
STORM ROUTING (EMER. SPWY W/ R.C. STORM)	17
STORM ROUTING SUMMARY	33
STORM ROUTING (EM. SPWY. FREEBOARD STORM)	34
WATER SURFACE PROFILES	38
COST COMPARISONS	42



NORWALK RIVER W.S.

SITE 7B ✓

AREA - STORAGE CURVES

PAR 7-16-71 CN-435-M

FILE 2-8-71

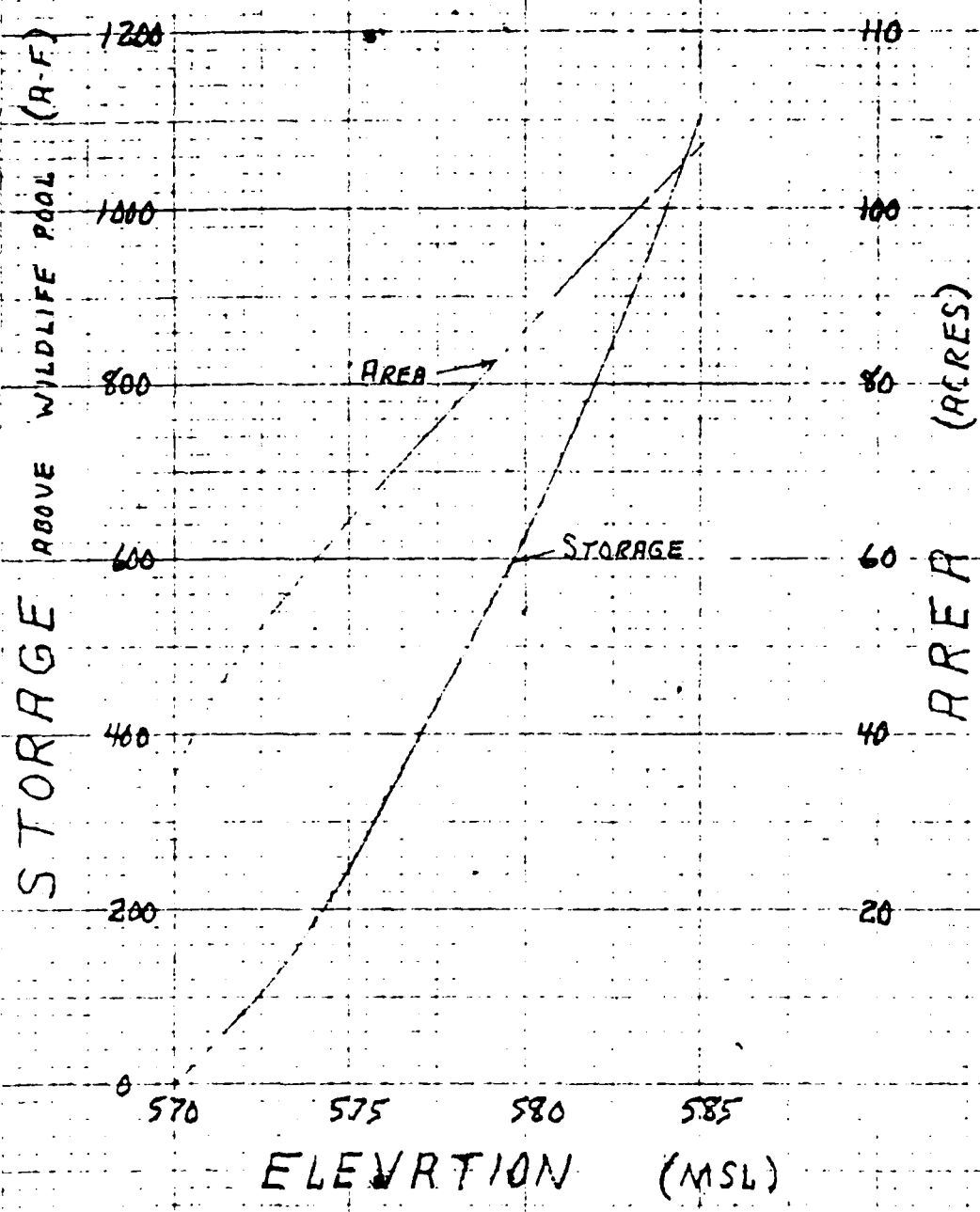

REPRODUCED BY GOVERNMENT PRINTING OFFICE

STATE: OHIO PROJECT: 72-1-10
 BY: DATE: CHECKED BY: DATE: 1/1/61
 SUBJECT: 1/2" INLET TO LCAI STAGE OR PICE - EL 577.0 SHEET 3 OF 3

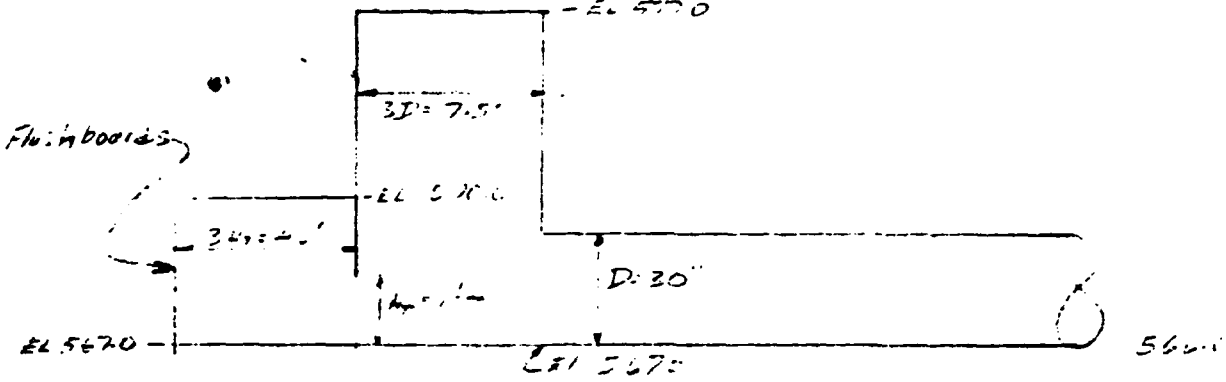

Find area of circular pipe of all equal
 33 CFS with W.S. @ EL 577.0

Assume $h = 0$ @ EL 569.5 1.500 prof. p.s. calc,
 (0.6164)

$$33 = C_d A \sqrt{2gh} = 0.6164 \times \frac{3}{4} D^2 \times 29 \sqrt{577.0 - 569.5}$$

$$A = \frac{33}{0.6164 \times 29 \times 1.35} = \frac{33}{24.2} = 2.43 \text{ ft}^2$$

$$H_f = \frac{2.42}{3140} = \frac{2.42}{1.35} = 1.3'$$

$$201 \frac{1' 10'' \times 1' 4''}{3140 \times H_f} = 2.44 \text{ ft}^2$$

Full Pipe Flow

$$C_{100} = C_d K_p \sqrt{h}$$

$$C_p = A_p \sqrt{\frac{2.9}{2.4 K_p \sqrt{h}}}$$

$$= 4.91 \sqrt{\frac{6.4}{2 \times 0.0786 \times 130}}$$

$$= 22.6$$

30" ID pipe
 $A_p = 4.91 \text{ ft}^2$
 $n = 0.012$
 $K_p = 0.0786$
 $S_p = 130'$

$h = 0$ @ EL 567.3

$$C_{100} = 22.6 \text{ hp ft}$$

RISER SKETCH

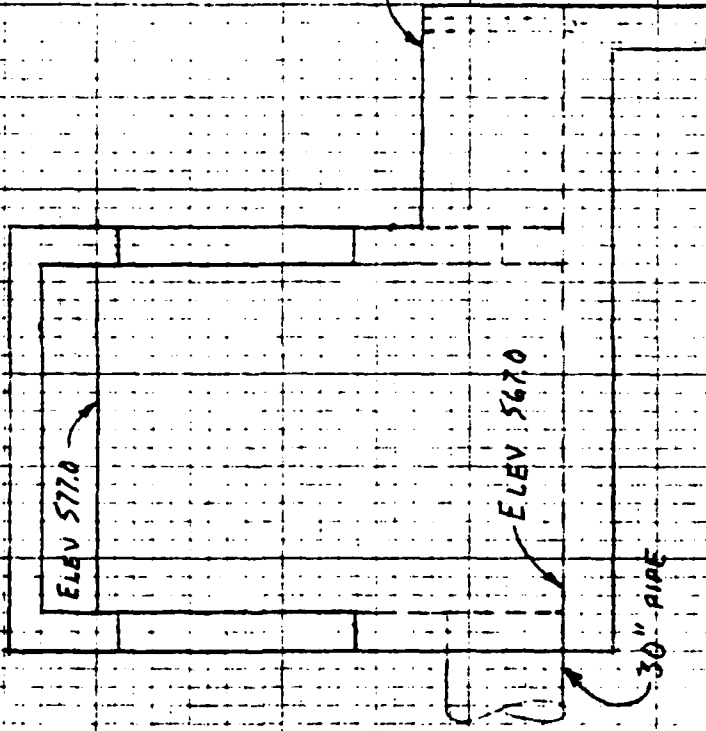
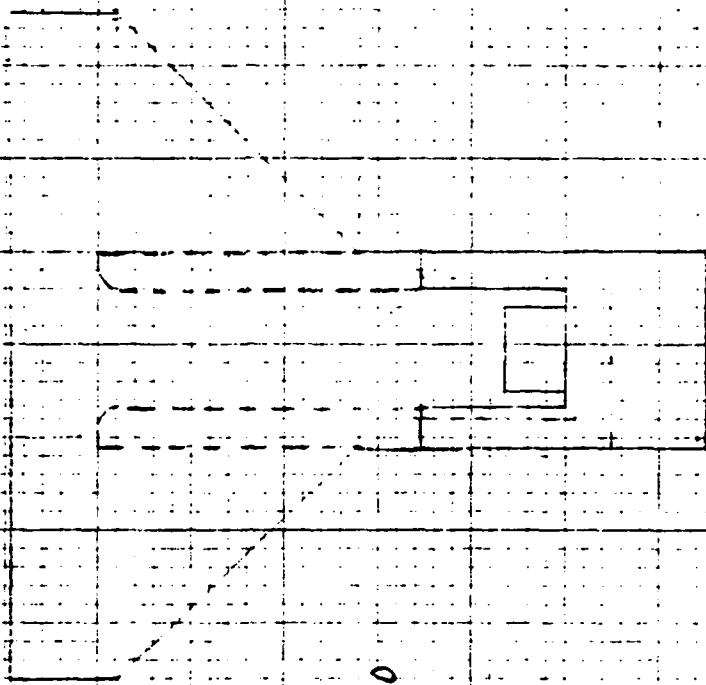

NUMBER FOUR
 SITE 7E
 STAG - Discharge
 CN-47514 7/14/71

PRINCIPAL SPILLWAY DISCHARGE (cfs)

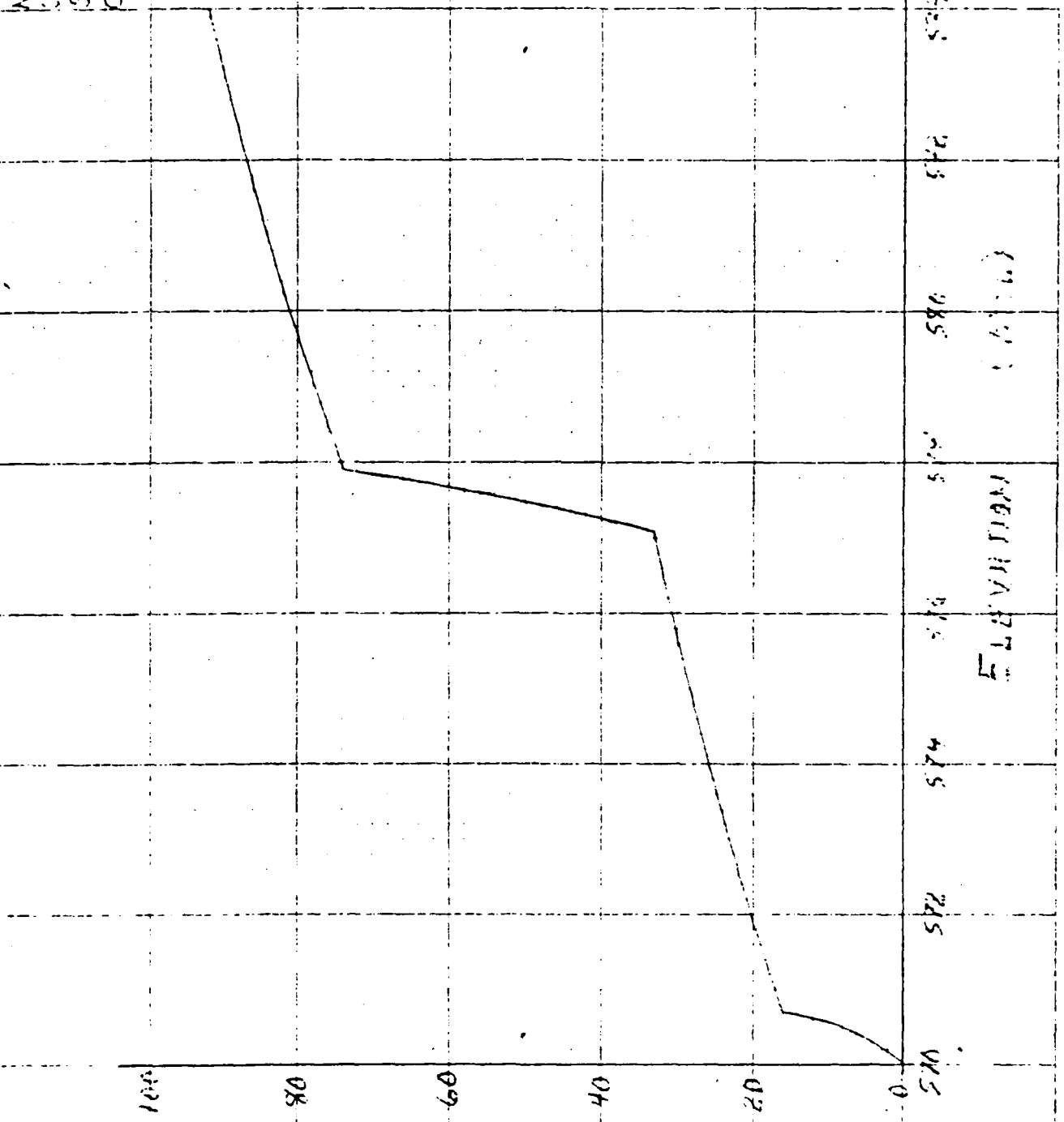

ELEVATION (ft)



CONN

PROJECT NORWALK R.W. SITE 78

CN-475-H

DESIGN DISCHARGE WATER LEVEL

THEORETICAL VELOCITY

$$V = \frac{1.486}{n} S^{1/2} R^{2/3}$$

③ ELEV 565 FOR AV. X-SECT

$$V = \frac{1.486}{0.045} (0.01)^{1/2} (1.81)^{2/3}$$

$$A = .7 + 7.5 + 10 + 3 + 3 = 24.2$$

$$P = 20'$$

$$R = 1.21$$

$$V = 3.7 \text{ ft/s}$$

$$A = \frac{Q}{V} = \frac{33}{3.7} = 8.9' < 24.2$$

$$n = 0.045$$

$$S = \frac{.7}{700} = 0.001$$

$$Q = 33$$

∴ DOWNSTREAM CHANNEL CAN CONVEY 33 ft BELOW ELEV. 565

USE ELEV. 566' AS INVERT ELEV.

CROSS-SECTIONS

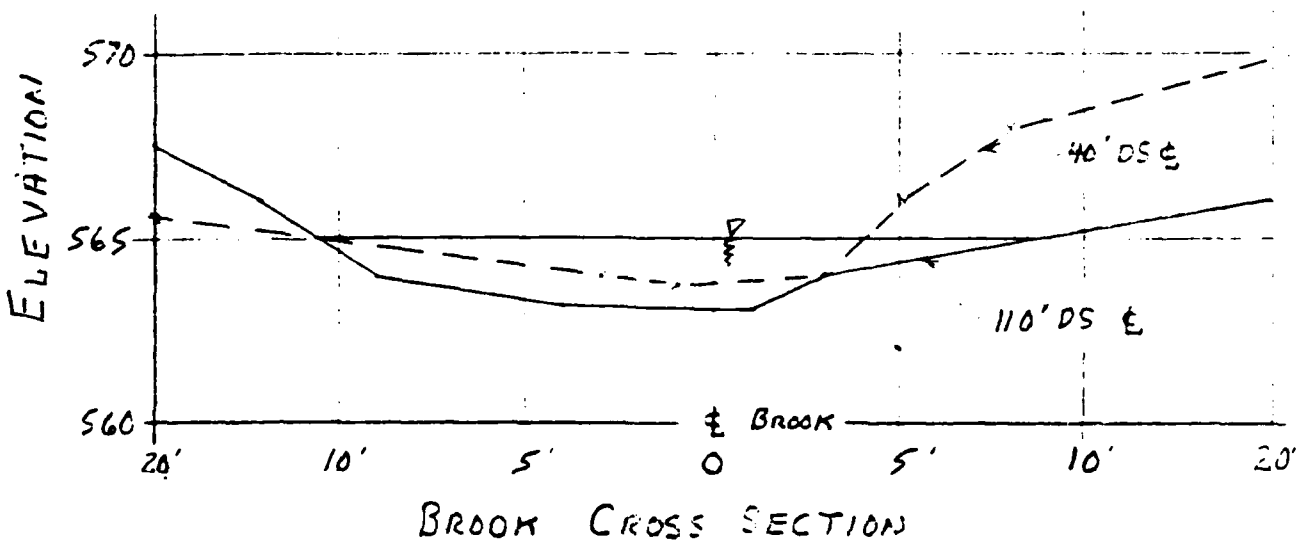

STATE

CONN

PROJECT

N-LOWWAY W/ 20' ALS.

BY FFR

DATE 7-10-71

CHECKED BY

DATE

DATE 7/10/71

JOB NO

013-1-30-17

SUBJECT

PRINCIPAL SPWY ROUTING SUMMARY

SHEET 12 OF

PRINCIPAL SPILLWAY ROUTING RESULTS:

100-yr - 24 hr STORM (VIOLK PLAN REQUIREMENT) - MAX ELEV 576.7 (SH 8)

100-yr - 10 day STORM W/ BASE FLOW - MAX ELEV 576.05 (SH 11)

TRY

RISER CREST @ ELEV. 577.0

EMERGENCY SPILLWAY CREST @ 577.0 & 578.0

w/ B = 15', 25' & 40' @ EACH ELEVATION

ROUTE EMERGENCY SPILLWAY DESIGN STORM

FROM 5-DAY DRAWDOWN STAGE OF

100-yr - 10 day STORM (ELEV 573.48).

(CHECK 5-DAY DRAWDOWN FROM SELECTED

CREST OF EMER. SPWY ASSUMING FULL POOL

TO CREST W/NO ADDITIONAL INFLOW)

STATE _____ PROJECT _____
 BY _____ DATE _____ CHECKED BY _____ DATE _____ JOB NO _____
 SUBJECT _____ SHEET _____ OF _____

DRAW DOWN TIME

ASSUME : NO INFLOW, POOL FULL TO EMER. SPWY CREST

ELEV.	STORAGE	DIFF STORAGE	DISCHARGE	Q _{AVE}	TIME	TIME TOTAL
578.0	472	72	74.0	53.5	0.68	
577.0	400	250	33.0	29.15	4.33	0.68
573.48	150	125	25.3	20.65	3.05	<u>5.01</u>
570.7	25	25	16.0	8.0	1.57	8.06
570.0	0	0	0			9.63

$$\frac{A-F}{A} \times 0.504 = \text{days}$$

5-DAY DRAWDOWN FROM SCS PRIN. SPWY ROUTING = 573.48

5-DAY DRAWDOWN FROM FULL POOL = ELEV 573.48

∴ EM SPWY DESIGN STORM ROUTED FROM ELEV = 573.48 ft!

DATE: 8-11-71

PROJECT

NORWALK RIVER W.D. SIDE 70

APP. 435-H

DATE: 8-11-71

PROJECT

DATE

APP. 435-H

SHEET 30 OF 31

REFER TO SHEETS 42 THRU 54 FOR
 ECONOMIC COMPARISONS OF THE SELECTED
 SPILLWAY EXCAVATION QUANTITIES AND
 ASSOCIATED EARTH FILL VOLUMES.

SELECTED ALTERNATIVE: CREST ELEV 578.0

BOTTOM WIDTH = 15'

PEAK Q = 662 cfs @ D/W N ELEV 583.36

@ W.S. ELEV 583.36

$Q_p = 90 \text{ cfs} \therefore Q_{om} = \underline{572 \text{ cfs}}$

$d_c = 3.3' \text{ (ES-24)}$

$A_c = 60.4 \text{ sq ft}$

$V_c = 9.46 \text{ fps}$

$\frac{V^2}{2g} = 1.39' \text{ (approx)}$

$H_{ec} = 4.7'$

EXIT CHANNEL $S_o = 0.022 \text{ #/ft}$ FOR $n = 0.04$

CONN
8-10-71

NORWALK RIVER W.S. SITE 7E ✓

EMERG. SAWY. WATER SURFACE PROFILE

EMERG. SAWY. ELEV = 578.0 & B = 15'

FROM ROUTING

Q = 662 Q_{EM} = 662 - 90 = 572 cfs

FROM ENERGY EQU.

d_c = 3.3' (ES-24)

A_c = 18.3 × 3.3 = 60.4'

v_c = $\frac{572}{60.4} = 9.46$ fps

FIND d_n for n = 0.035 S₀ = 0.022 & Q = 572 cfs

$572 = \frac{1.486}{0.035} (0.022)^{1/2} (AR^{2/3})$

9R^{2/3} = 90.8

d = 2.9

A = 2.9 (17.9) = 51.9

WP = 23.2

R = 2.24

R^{2/3} = 1.71

AR^{2/3} = 88.8

d = 2.93

A = 52.5

WP = 23.3

R = 2.25

R^{2/3} = 1.72

AR^{2/3} = 90.3 ≈ 90.8

d_n = 2.93'

FOR AREA AND HYDRAULIC RADIUS PLOT

@ d = 3.15

A = 3.15 × 18.15 = 57.2

WP = 23.9

R = 2.39

@ d = 3.3

A = 60.4

WP = 24.33

R = 2.48

STATE _____ PROJECT _____
BY _____ DATE _____ CHECKED BY _____ DATE _____ JOB NO _____
SUBJECT EM. EROD. AREA HYDRAULIC RADIUS SHEET _____ OF _____

$b=15$
 $Z=1$

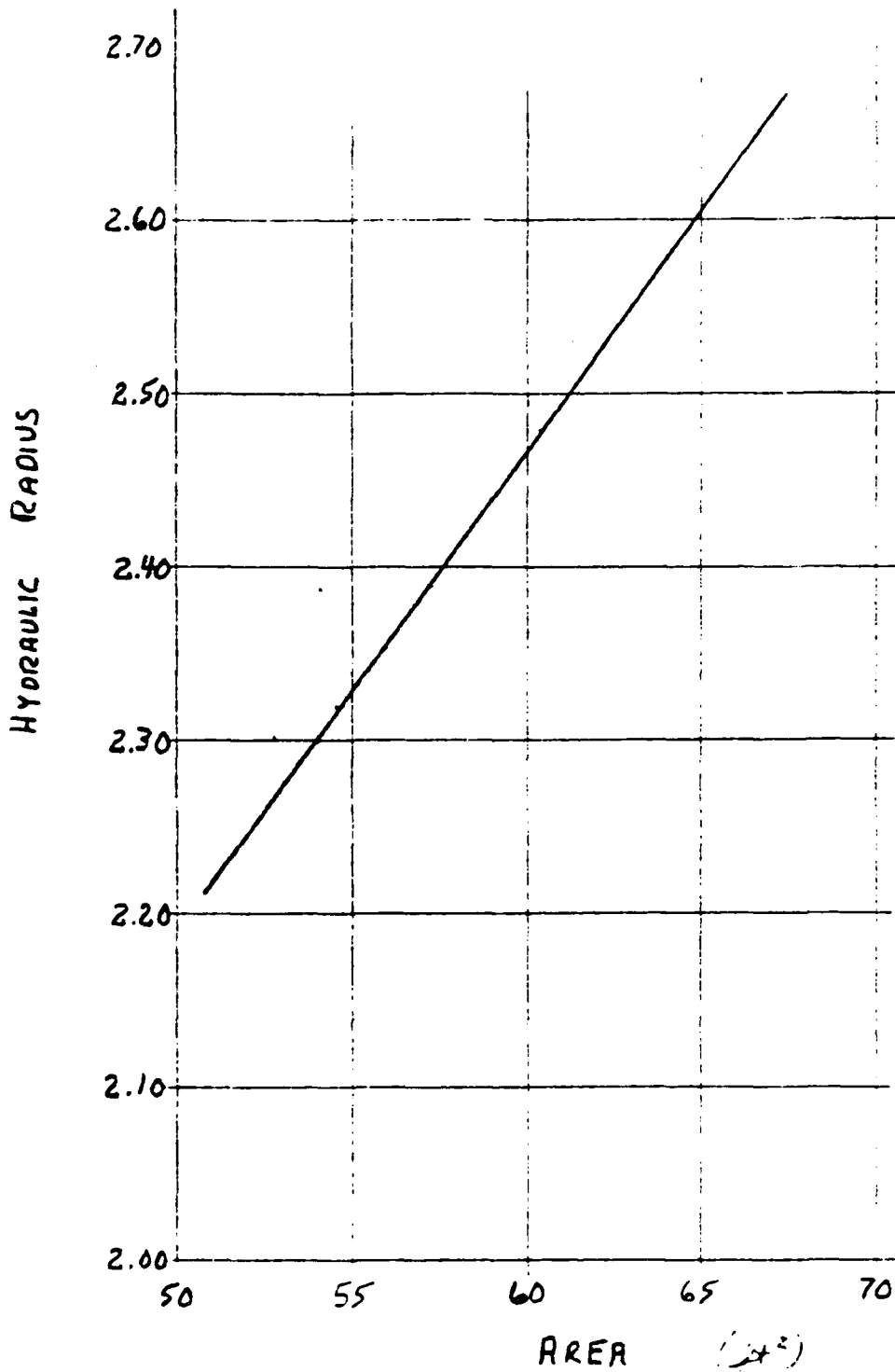

APPENDIX C

PHOTOGRAPHS

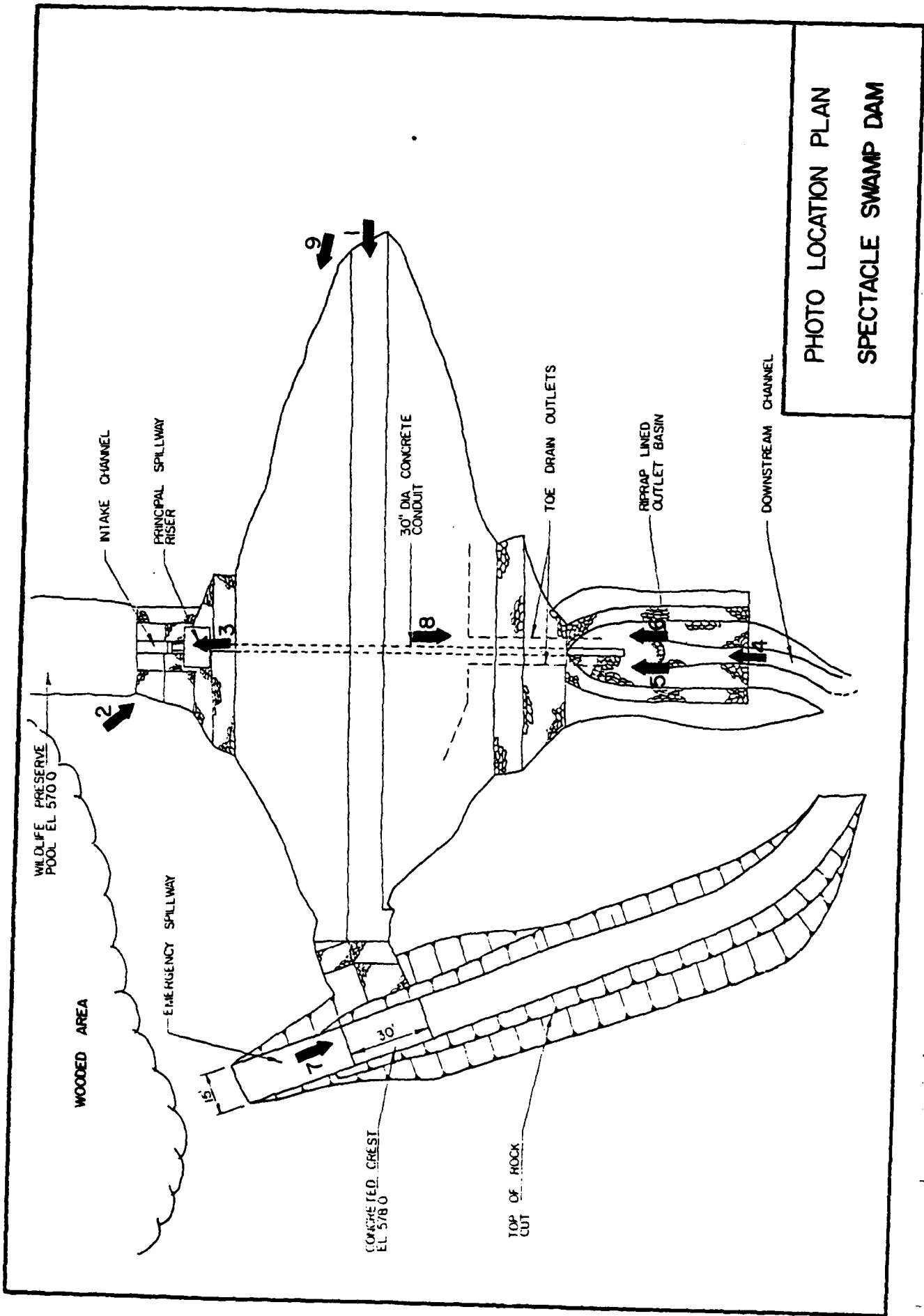

PHOTO LOCATION PLAN
SPECTACLE SWAMP DAM



Photo 1 Top and Slopes of Embankment.



Photo 2 Principal Spillway Riser and Low-Level Intake.



Photo 3 Low-Level Intake



Photo 4 Outlet of Principal Spillway Culvert and Spillway Channel.

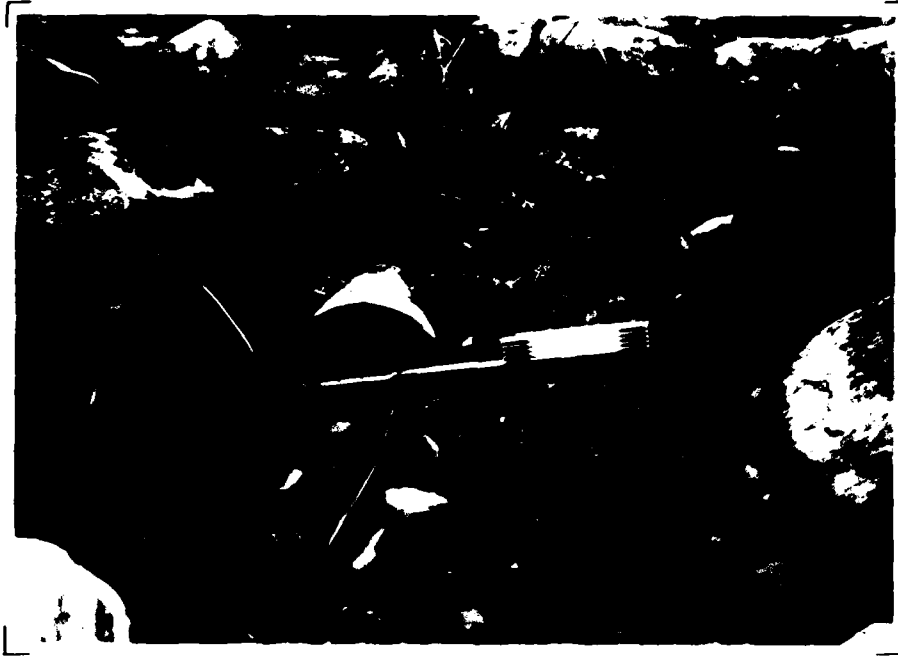

Photo 5 Right Outlet of Toe Drain.

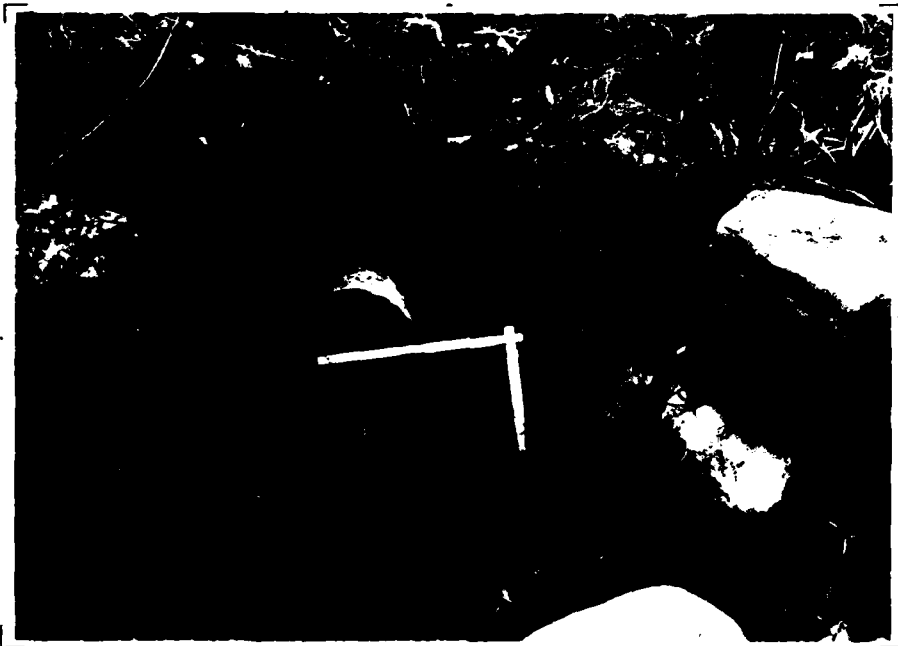

Photo 6 Left Outlet of Toe Drain.



Photo 7 Crest of Emergency Spillway.

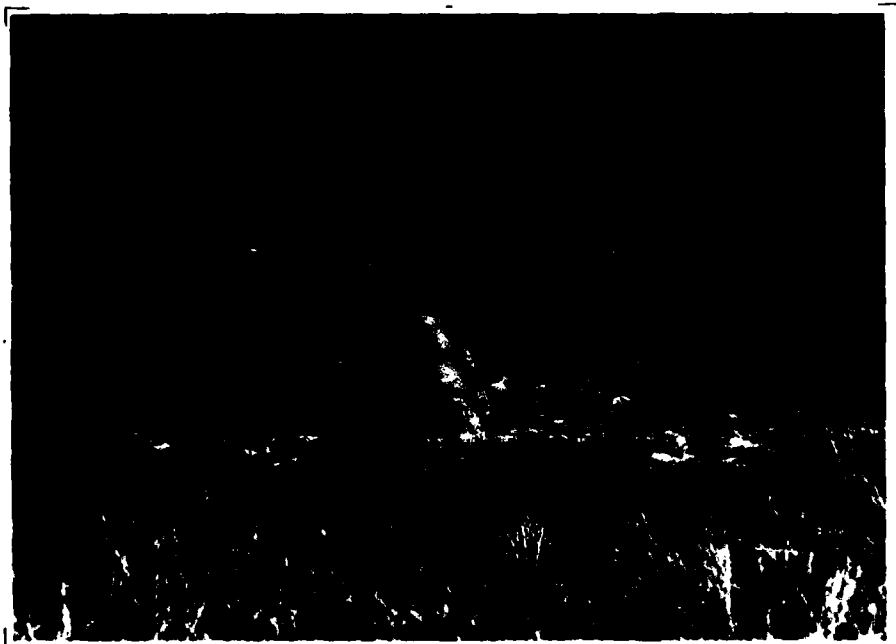

Photo 8 Spillway and Downstream Channel.



Photo 9. Wooded area of emergency spillway entrance (background) and principal spillway riser (foreground).

APPENDIX D

HYDROLOGIC AND HYDRAULIC COMPUTATIONS

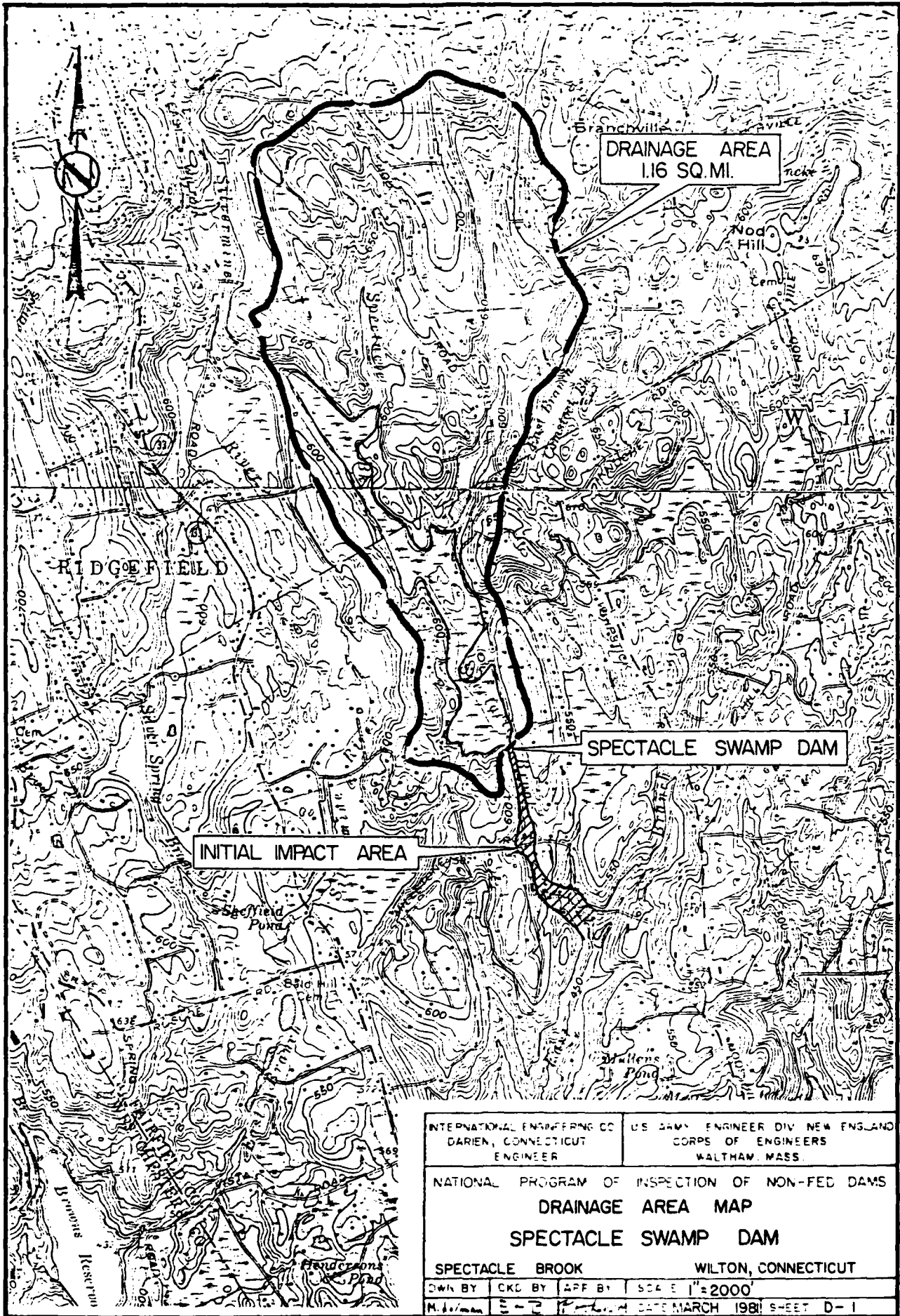

INTERNATIONAL ENGINEERING CO DARIEN, CONNECTICUT ENGINEER	US DAM ENGINEER DIV NEW ENGLAND CORPS OF ENGINEERS WALTHAM, MASS.
NATIONAL PROGRAM OF INSPECTION OF NON-FED DAMS	
DRAINAGE AREA MAP	
SPECTACLE SWAMP DAM	
SPECTACLE BROOK	WILTON, CONNECTICUT
DRAWN BY CKD BY APP BY SCA E 1"=200'	
M. 10/1981 E-2 P. 10/1981 DATE MARCH 1981 SHEET D-1	

Project NATIONAL DAM INSPECTION PROGRAM (NDIP)Contract No. 2616-07

File No. _____

Feature SPECTACLE SWAMP DAMDesigned MPDate 12/19/80

Item _____

Checked EHR BDate 1/19/81

HYDROLOGIC / HYDRAULIC INSPECTION

SPECTACLE SWAMP DAM, WILTON, CT1. PERFORMANCE AT PEAK FLOOD CONDITIONS

1. PROBABLE MAXIMUM FLOOD

a. WATERSHED CLASSIFIED AS "ROLLING"

b. WATERSHED AREA = 1.16 sq. mi.*

c. EXTRAPOLATING FROM NED-ACE GUIDE CURVES

$$PMF \approx 2300 \text{ cfs/sq. mi.}$$

d. THEREFORE, PEAK INFLOW:

$$PMF = 2300 \times 1.16 \approx 2700 \text{ cfs}$$

$$\frac{1}{2} PMF = 1350 \text{ cfs}$$

2. SURCHARGE AT PEAK INFLOWS (PMF AND $\frac{1}{2}$ PMF).

a. OUTFLOW RATING CURVE.

(1) CASE 1: NORMAL POOL AT EL. 570.0 (DESIGN NORMAL POOL)

i. SPILLWAYS

SPECTACLE SWAMP DAM HAS TWO SPILLWAYS. THE PRINCIPAL

SPILLWAY, IN THE CENTER OF THE EMBANKMENT, IS A CONCRETE

RECTANGULAR VERTICAL SHAFT WITH STRAIGHT SHARP

* NOTE: DRAINAGE AREA FROM "NORWALK RIVER WATERSHED PROJECT", 1972 AND IECO MEASUREMENTS ON U.S.G.S. NORWALK NORTH, CT AND BETHEL, CT QUADRANGLE MAPS.



Project NDIP
 Feature SPECTACLE SPILLWAY DAM
 Item _____

Contract No. 2416-07
 Designed MP
 Checked EKB

Sheet D-2
 File No. _____
 Date 12/19/80
 Date 1/19/80

CRESTED WEIRS ON BOTH SIDES. EACH WEIR IS 7.5-FT-LONG AND HAS
 CREST ELEVATION OF 5770 MSLD. THE SPILLWAY CREST IS 8.5 FT BELOW
 THE TOP OF THE DAM. THERE IS A 148-FT-LONG, 30-IN. DIAMETER
 R.C. CONDUIT THAT EXTENDS FROM THE BOTTOM OF THE SPILLWAY
 SHAFT TO THE DOWNSTREAM SLOPE. THE SPILLWAY SHAFT IS SPANNED
 BY A CONCRETE SLAB WHICH IS 1.25 FT ABOVE THE SPILLWAY CREST.

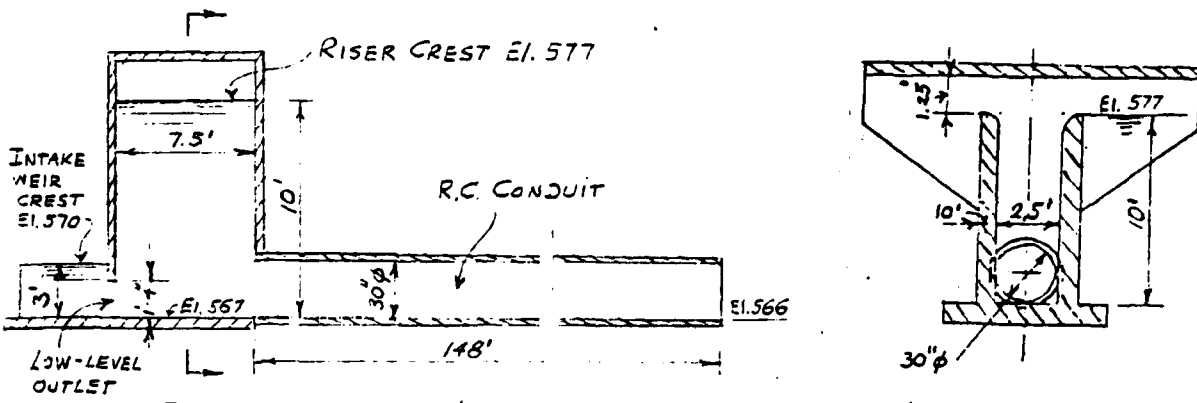

THE EMERGENCY SPILLWAY, LOCATED ON THE RIGHT SIDE OF THE EMBANKMENT,
 IS AN UNLINED CHANNEL WITH A 15-FT-LONG CONCRETED CREST AT ELEVATION 578 MSLD,
 30 FT IN WIDTH (1 FT ABOVE THE PRINCIPAL SPILLWAY CREST). THE SLOPE SIDES OF THE CHANNEL VARY FROM 1H
 TO 1V (Z=1) TO 3H TO 1V (Z=3), AS A RESULT, Z=2 WILL BE USED IN SUBSEQUENT CALCULATIONS. ASSUMING $K=0.6$ FOR
 THE PRINCIPAL SPILLWAY CONDUIT, $C=2.7$ FOR THE EMERGENCY SPILLWAY, NEGLECTING THE FLOW THROUGH
 THE UNGATED LOW-LEVEL OUTLET AND USING THE INTAKE CREST WEIR AS DATUM (EL. 570.0)
 THE COMBINED DISCHARGE OF THE SPILLWAYS IS APPROXIMATED BY:

SEE NOTE ON P. D-10

Project NDI.D

Contract No. 2616-D

File No. _____

Feature SPECTACLE SWAMP DAM

Designed MC

Date 12/19/80

Item _____

Checked FHS

Date 1/17/81

(1) PRINCIPAL SPILLWAY:

$$(Q_s)_1 = K_2 \sqrt{2g} (H+3) = 0.6 \times 4.91 \times 8.02 (H+3)^{1/2} = 23.6 (H+3)^{1/2}$$

($H \gg 3$, ASSUMING NO TAILWATER EFFECTS)

(2) EMERGENCY SPILLWAY:

EQUIVALENT LENGTH OF EACH SLOPING PORTION IS

$$L_s \approx \frac{2}{5} z h = \frac{2}{5} \times 2 \times (H-3) = 0.8 (H-3)$$

$$\therefore (Q_s)_2^s = C L_s (H-3)^{3/2} = 2.7 \times 0.8 (H-3)^{5/2} = 2.16 (H-3)^{5/2}$$

SPILLWAY BOTTOM:

$$(Q_s)_2^b = C L_b (H-3)^{3/2} = 2.7 \times 15 \times (H-3)^{3/2} = 40.5 (H-3)^{3/2}$$

THEREFORE, TOTAL DISCHARGE OF EMERGENCY SPILLWAY:

$$(Q_s)_2 = 2(Q_s)_2^s + (Q_s)_2^b = 4.3 (H-3)^{5/2} + 40.5 (H-3)^{3/2}$$

THE COMBINED DISCHARGE OF THE SPILLWAYS WITH THE WATER SURFACE AT THE TOP OF THE DAM IS APPROXIMATED BY:

$$Q_s \approx 23.6 (H+3)^{1/2} + 40.5 (H-3)^{3/2} + 4.3 (H-3)^{5/2}$$

ii. EXTENSION OF THE RATING CURVE FOR SURCHARGE OVERTOPPING THE DAM AND/OR ADJACENT TERRAIN.

THE SPECTACLE SWAMP DAM IS AN EARTHFILL EMBANKMENT WITH A TOP ELEVATION OF 585.5 AND TOTAL LENGTH OF 250 ± FT. THE TERRAIN ADJACENT TO THE RIGHT SIDE OF THE DAM IS SLOPED AT

Project NDIP
 Feature SPECTACLE SWAMP DAM
 Item _____

Sheet D-4
 Contract No. 26.6-57 File No. _____
 Designed M Date 12/9/60
 Checked EAC Date 1/19/61

APPROXIMATELY 20:1. THE TERRAIN ADJACENT TO THE LEFT SIDE OF THE DAM HAS A SLOPE OF ABOUT 4:1 (SEE SKETCH BELOW).

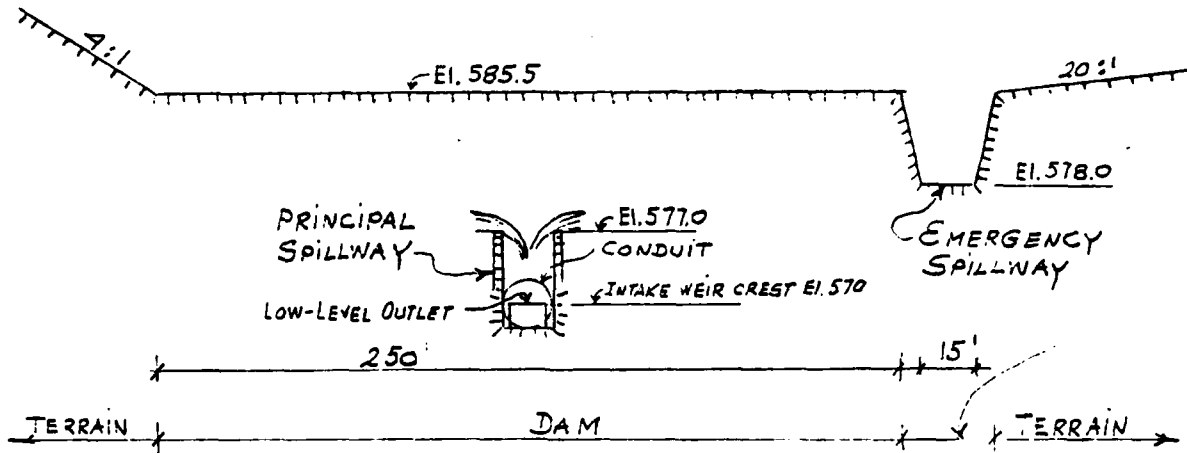

ASSUMING $C=2.7$ FOR THE OVERFLOW AT ALL OVERTOPPING POINTS AND EQUIVALENT LENGTH FOR THE SLOPING TERRAIN, THE OVERFLOW CAN BE APPROXIMATED BY THE FOLLOWING EQUATIONS:

(1) SLOPING TERRAIN TO THE RIGHT OF THE DAM:

$$L_{RS} = 2/5 \times 20 (H - 15.5); \quad \therefore Q'_{RS} = 2.7 \times 8 \times (H - 15.5)^{5/2} \approx 21.6 (H - 15.5)^{5/2}$$

(2) TOP OF DAM AT EL. 585.5

$$Q'_D = 2.7 \times 250 \times (H - 15.5)^{3/2} = 675 (H - 15.5)^{3/2}$$

(3) SLOPING TERRAIN TO THE LEFT OF THE DAM:

$$L_{LS} = 2/5 \times 4 (H - 15.5); \quad \therefore Q'_{LS} = 2.7 \times 1.6 \times (H - 15.5)^{5/2} \approx 4.3 (H - 15.5)^{5/2}$$



Project NDIP
 Feature SPECTACLE SWAMP DAM
 Item _____

Contract No. 2616-27 File No. _____
 Designed MP Date 12/19/80
 Checked EMK Date 1/19/81

THEREFORE, THE TOTAL OUTFLOW RATING CURVE IS APPROXIMATED BY :

$$Q_T = 23.6(H+3)^{1/2} + 40.5(H-8)^{3/2} + 4.3(H-8)^{5/2} + 675(H-15.5)^{3/2} + 25.9(H-15.5)^{5/2}$$

THE RESULTING OUTFLOW RATING CURVE IS AS FOLLOWS :

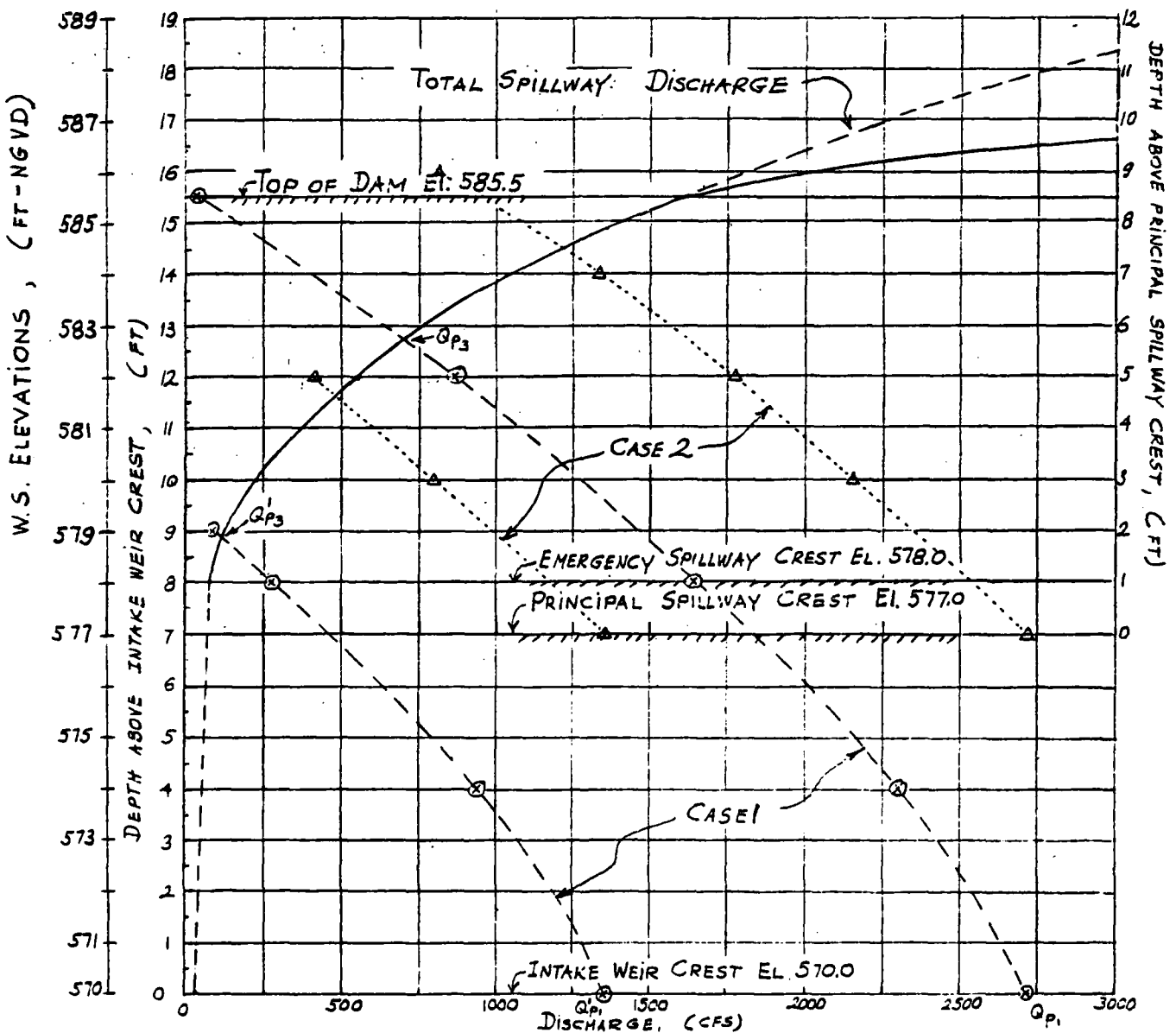

b. SURCHARGE HEIGHT TO PASS PEAK INFLOWS (Q_p AND Q'_p)

i. @ $Q_p = PMF \approx 2700$ CFS ; $H_s \approx 16.5$ FT

ii @ $Q'_p = 1/2 PMF = 1350$ CFS ; $H'_s = 14.3$ FT



Project 1350
 Feature SPECTACLE SLAVE DAM
 Item _____

Sheet 375
 File No. _____
 Designed MP Date 6/2/66
 Checked ERS ly Date 11/2/66

C. EFFECT OF SURCHARGE STORAGE ON PEAK OUTFLOWS:

i. ASSUME NORMAL POOL ELEVATION AT LOW-LEVEL INTAKE
 WEIR CREST (EL. 570.0).

ii. WATERSHED AREA: DA = 1.16 SQ. MI. (SEE P. D-1)

iii. DISCHARGE Q_{P2} AT VARIOUS HYPOTHETICAL SURCHARGE
 ELEVATIONS:

POOL STORAGE AT NORMAL POOL EL. 570.0: $V_0^* = 34$ AC-FT

H = 15.5 FT; POOL STORAGE $V_1^* = 1194$ AC-FT

SURCHARGE STORAGE $V = V_1 - V_0 = 1194 - 34 = 1160$ AC-FT

$$\text{RUNOFF } S = \frac{V}{53.3 \times DA} = \frac{1160}{53.3 \times 1.16} = 18.76 \text{ IN}$$

H = 12 FT; $V_1^* = 835$ AC-FT; $V = 835 - 34 = 801$ AC-FT

$$S = 12.96 \text{ IN}$$

H = 8 FT; $V_1^* = 500$ AC-FT; $V = 500 - 34 = 466$ AC-FT

$$S = 7.54 \text{ IN}$$

H = 4 FT; $V_1^* = 214$ AC-FT; $V = 214 - 34 = 180$ AC-FT

$$S = 2.91 \text{ IN}$$

* FROM "NORWALK RIVER WATERSHED PROJECT", 1972;
 SEE STAGE-STORAGE RATING CURVES ON P. D-7.



INTERNATIONAL ENGINEERING COMPANY, INC.

Project _____
Feature _____
Item _____

Contract No. _____
Designed _____
Checked E.P. O'G

Sheet _____
File No. _____
Date _____
Date _____

SPECTACLE SWAMP DAM RESERVOIR

STAGE-STORAGE RATING CURVES*

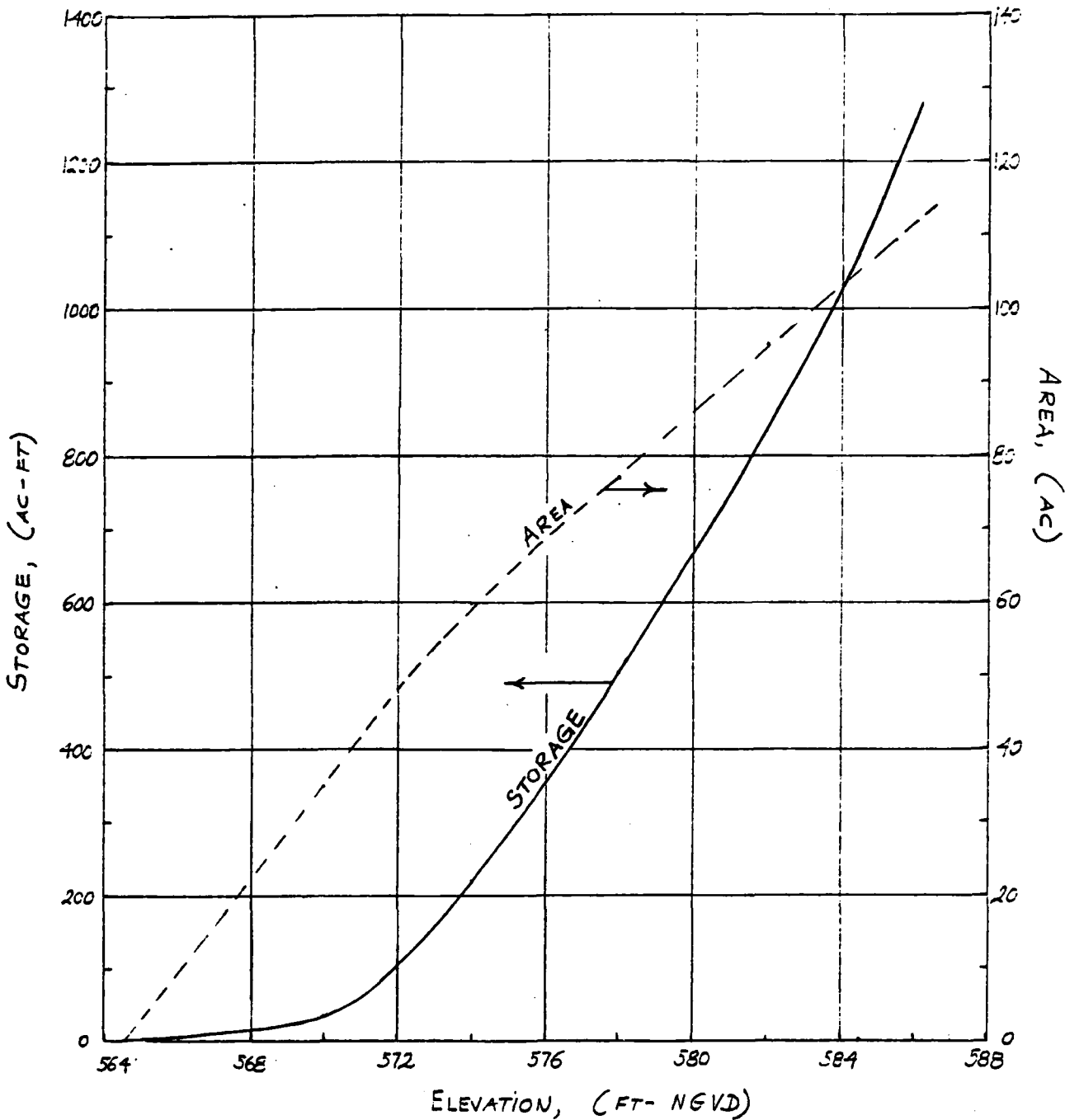

* FROM "NORWALK RIVER WATERSHED PROJECT", 1972





Project NDJR
 Feature WHEELER DAM
 Item _____

Contract No. 2616-57 File No. _____
 Designed W.P. Date 12/9/50
 Checked W.P. Date 1/19/51

FROM APPROXIMATE ROUTING NED-ACE GUIDELINES AND 19 IN

MAXIMUM PROBABLE RUNOFF IN NEW ENGLAND:

$$Q_{p_2} = Q_{p_1} \left(1 - \frac{S}{19}\right) \text{ AND FOR } \frac{1}{2} \text{ PMF:}$$

$$Q_{p_2}' = Q_{p_1}' \left(1 - \frac{S}{9.5}\right)$$

∴ FOR THE PREVIOUS HYPOTHETICAL SURCHARGES:

$$H = 15.5 \text{ FT; } Q_{p_2} = 34 \text{ CFS;}$$

$$H = 12 \text{ FT; } Q_{p_2} = 858 \text{ CFS;}$$

$$H = 8 \text{ FT; } Q_{p_2} = 1629 \text{ CFS; } Q_{p_2}' = 279 \text{ CFS}$$

$$H = 4 \text{ FT; } Q_{p_2} = 2286 \text{ CFS; } Q_{p_2}' = 936 \text{ CFS}$$

d. PEAK OUTFLOWS (Q_{p_3} AND Q_{p_3}')

USING NED-ACE GUIDELINES "SURCHARGE STORAGE ROUTING"

ALTERNATE METHOD AND RATING CURVE (SEE P. D-5):

$$Q_{p_3} = 700 \text{ CFS; } H_3 = 12.7 \text{ FT FOR } Q_{p_1} = \text{PMF}$$

$$Q_{p_3}' = 120 \text{ CFS; } H_3' = 8.9 \text{ FT FOR } Q_{p_1}' = \frac{1}{2} \text{ PMF}$$

Project AJIP
 Feature SPECTACLE SWAMP DAM
 Item _____

Contract No. 2616-07
 Designed M.P.
 Checked FHR By _____

Sheet 2-2
 File No. _____
 Date 12-2-57
 Date 11-2-59

3. SPILLWAY CAPACITY RATIO TO PEAK INFLOWS AND OUTFLOWS:

a. SPILLWAY CAPACITY TO EMERGENCY SPILLWAY CREST (E1.578)

$$H_1 = 8 \text{ FT}; \quad (Q_s)_1 = 78 \text{ CFS}$$

∴ THE TOTAL SPILLWAY CAPACITY TO EMERGENCY SPILLWAY CREST ELEVATION IS (\pm) 3% OF THE INFLOW (Q_{P_1}) AND (\pm) 11% OF THE OUTFLOW (Q_{P_3}) AT PEAK FLOOD = PMF.

LIKewise, THE TOTAL SPILLWAY CAPACITY TO EMERGENCY SPILLWAY CREST ELEVATION IS (\pm) 6% OF THE INFLOW (Q_{P_1}') AND (\pm) 65% OF THE OUTFLOW (Q_{P_3}') AT PEAK FLOOD = $\frac{1}{2}$ PMF.

b. SPILLWAY CAPACITY TO TOP OF DAM (E1.585.5):

$$H_2 = 15.5 \text{ FT}; \quad (Q_s)_2 = 1596 \text{ CFS} \quad (\text{TOTAL OF BOTH SPILLWAYS})$$

∴ THE TOTAL SPILLWAY CAPACITY TO TOP OF DAM IS (\pm) 59% OF THE INFLOW (Q_{P_1}) AND (\pm) 228% OF THE OUTFLOW (Q_{P_3}) AT PEAK FLOOD = PMF.

LIKewise, THE TOTAL SPILLWAY CAPACITY TO TOP OF DAM IS (\pm) 118% OF THE INFLOW (Q_{P_1}') AND (\pm) 1330% OF THE OUTFLOW (Q_{P_3}') AT PEAK FLOOD = $\frac{1}{2}$ PMF.

c. SPILLWAY CAPACITY TO PMF AND $\frac{1}{2}$ PMF SURCHARGE (TEST FLOOD):

i. CAPACITY TO PMF SURCHARGE (TOTAL OF BOTH SPILLWAYS):

$$H_3 = 12.7 \text{ FT}; \quad (Q_s)_3 = 713 \text{ CFS}$$



INTERNATIONAL ENGINEERING COMPANY, INC.

Sheet D-10

Project NDIP
 Feature SPECTACLE SWAMP DAM
 Item _____

Contract No. 2616-07 File No. _____
 Designed MP Date 12/19/80
 Checked EHS Date 1/17/81

∴ THE TOTAL SPILLWAY CAPACITY TO PMF SURCHARGE IS ^(±) 26 %
 OF THE INFLOW (Q_P) AND ^(±) 100% OF THE OUTFLOW (Q_{P3}) AT
 PEAK FLOOD = PMF.

ii. CAPACITY TO 1/2 PMF SURCHARGE (TOTAL OF BOTH SPILLWAYS) :

$$H_3^1 = 8.9 \text{ FT}; \quad (Q_S)_4 = 119 \text{ CFS.}$$

∴ THE TOTAL SPILLWAY CAPACITY TO 1/2 PMF SURCHARGE IS
^(±) 9 % OF THE INFLOW (Q_P^1) AND ^(±) 100% OF THE OUTFLOW
 (Q_{P3}^1) AT PEAK FLOOD = 1/2 PMF.

NOTE: THE SPECTACLE SWAMP DAM HAS A 1'-10" (W) BY 1'-4" (H)
 POOL DRAIN WITH INVERT EL. 567. THE DRAIN IS INCORPORATED
 IN THE UPSTREAM WALL OF THE PRINCIPAL SPILLWAY RISER AND
 USES THE 30 IN. AND 148-FT-LONG SPILLWAY CONDUIT AS
 AN OUTLET. THE POOL DRAIN CAPACITY UNDER 10 FT
 OF HEAD (PRINCIPAL SPILLWAY CREST EL. 577.0) IS
 ESTIMATED TO BE ^(±) 36 CFS. CONTROL PASSES TO THE PRINCIPAL
 SPILLWAY AT $H \geq 8$.





Project NDIP
Feature SPECTACLE SWAMP DAM
Item _____

Contract No. 2616-07
Designed MP
Checked EMB ly
File No. _____
Date 12/19/20
Date 1/13/81

(2) CASE 2: NORMAL POOL AT PRINCIPAL SPILLWAY CREST EL. 577.0
(PLUGGED LOW-LEVEL INTAKE)

a. USING THE SAME ASSUMPTIONS AS EMPLOYED IN CASE 1, THE RESULTING

OUTFLOW CURVE IS APPROXIMATED BY:

$$Q = 23.6 (H+10)^{1/2} + 40.5 (H-1)^{3/2} + 1.3 (H-1)^{5/2} + 675 (H-2.5)^{3/2} + 25.9 (H-2.5)^{5/2}$$

THE RESULTING OUTFLOW CURVE HAS THE SAME SHAPE AS IN CASE 1

AND IS SHOWN P. D-5, USING THE PRINCIPAL SPILLWAY CREST EL. 577.0

AS A DATUM.

b. SURCHARGE HEIGHT TO PASS PEAK INFLOWS (Q_p AND Q_p')

i. @ $Q_p = PMF = 2700$ CFS ; $H_1 \approx 9.5$ FT

ii. @ $Q_p' = 1/2 PMF = 1350$ CFS ; $H_1' \approx 7.9$ FT

c. EFFECT SURCHARGE STORAGE ON PEAK OUTFLOWS.

i. DISCHARGE Q_p AT VARIOUS HYPOTHETICAL SURCHARGE ELEVATIONS:

POOL STORAGE AT NORMAL POOL EL 577.0 : $V_0^* = 425$ AC-FT

$H = 9$ FT ; $V_1^* = 1250$; $V = 1250 - 425 = 825$ AC-FT ; $\therefore S = \frac{825}{53.3 \times 1.16} = 13.34$ IN

$H = 7$ FT ; $V_1^* = 1025$ AC-FT ; $V = 1025 - 425 = 600$ AC-FT ; $\therefore S = 3.70$ IN

$H = 5$ FT ; $V_1^* = 835$ AC-FT ; $V = 835 - 425 = 410$ AC-FT ; $\therefore S = 6.63$ IN

$H = 3$ FT ; $V_1^* = 670$ AC-FT ; $V = 670 - 425 = 245$ AC-FT ; $\therefore S = 3.96$ IN



Project
Feature
ItemNDZP
SPECTACLE SWAMP DAMContract No. 2616-07

File No. _____

Designed MPDate 12/10/80Checked EHG NYDate 11/19/81

∴ FOR THE PREVIOUS HYPOTHETICAL SURCHARGES:

$$H = 9 \text{ FT}; \quad Q_{P_2} = 804 \text{ CFS}$$

$$H = 7 \text{ FT}, \quad Q_{P_2} = 1322 \text{ CFS}$$

$$H = 5 \text{ FT}, \quad Q_{P_2} = 1758 \text{ CFS}$$

$$Q_{P_2}' = 408 \text{ CFS}$$

$$H = 3 \text{ FT}; \quad Q_{P_2} = 2137 \text{ CFS}$$

$$Q_{P_2}' = 787 \text{ CFS}$$

d. PEAK OUTFLOWS (Q_{P_3} AND Q_{P_3}')

USING NED-ACE GUIDELINES "SURCHARGE STORAGE ROUTING"

ALTERNATE METHOD AND OUTFLOW RATING CURVE (SEE P. D-5):

$$Q_{P_3} = 1233 \text{ CFS}; \quad H_3 = 7.5 \text{ FT} \quad \text{FOR } Q_{P_1} = \text{PMF}$$

$$Q_{P_3}' = 480 \text{ CFS}; \quad H_3' = 4.65 \text{ FT} \quad \text{FOR } Q_{P_1}' = 1/2 \text{ PMF}$$

3. SPILLWAY CAPACITY RATIO TO PEAK INFLOWS AND OUTFLOWS

a. SPILLWAY CAPACITY TO EMERGENCY SPILLWAY CREST (EL. 578.0)

$$H = 1 \text{ FT}; \quad Q = 78 \text{ CFS}$$

∴ TOTAL SPILLWAY CAPACITY TO EMERGENCY SPILLWAY CREST ELEVATION IS

(±) 3% OF THE INFLOW (Q_{P_1}) AND (±) 6% OF THE OUTFLOW (Q_{P_3}) AT PEAK FLOOD = PMF

AND (±) 6% OF Q_{P_1} AND (±) 16% OF Q_{P_3} AT PEAK FLOOD = 1/2 PMF



Project NDIP
 Feature SPECTACLE SHANE DAM
 Item _____

Sheet 3-3
 Contract No. 2616-C7 File No. _____
 Designed MIP Date 2/9/57
 Checked EMR Date 1/19/57

b. SPILLWAY CAPACITY TO TOP OF DAM (EL. 585.5)

$H = 8.5 \text{ FT}; Q = 1596 \text{ CFS}$ (TOTAL OF BOTH SPILLWAYS)

∴ THE TOTAL SPILLWAY CAPACITY TO TOP OF DAM IS ^(±) 59% OF INFLOW (Q_p)
 AND ^(±) 121% OF OUTFLOW Q_{p2} AT PEAK FLOOD = PMF AND ^(±) 118% OF Q_{p1}
 AND ^(±) 333% OF Q_{p3} AT PEAK FLOOD = $\frac{1}{2}$ PMF.

c. SPILLWAY CAPACITY TO PMF AND $\frac{1}{2}$ PMF SURCHARGE (TEST FLOOD)

i. CAPACITY TO PMF SURCHARGE (TOTAL OF BOTH SPILLWAYS):

$H_3 = 7.5 \text{ FT}; Q = 1238 \text{ CFS}$

∴ THE TOTAL SPILLWAY CAPACITY TO PMF SURCHARGE IS ^(±) 49% OF THE
 INFLOW (Q_p) AND ^(±) 100% OF THE OUTFLOW (Q_{p2}) AT PEAK FLOOD = PMF.

ii. CAPACITY TO $\frac{1}{2}$ PMF SURCHARGE (TOTAL OF BOTH SPILLWAYS):

$H_3' = 4.65 \text{ CFS}; Q = 481 \text{ CFS}$

∴ THE TOTAL SPILLWAY CAPACITY TO $\frac{1}{2}$ PMF SURCHARGE IS ^(±) 35% OF
 THE INFLOW (Q_{p1}) AND ^(±) 100% OF THE OUTFLOW (Q_{p3}) AT PEAK FLOOD = $\frac{1}{2}$ PMF.

Project NDIP
 Feature SPECTACLE SWAMP DAM
 Item _____

Sheet D-14
 Contract No. 2616-07 File No. _____
 Designed TMP Date 12/19/80
 Checked ELB Date 1/19/81

II. DOWNSTREAM FAILURE HAZARD

1. POTENTIAL IMPACT AREA

A NUMBER OF HOUSES LOCATED ALONG SPECTACLE BROOK DOWN TO THE NORTH-WESTERN AREA OF THE CITY OF WILTON AND, PARTICULARLY, THOSE LOCATED ^(±) 700 FT TO ^(±) 2500 FT DOWNSTREAM OF THE DAM, NEAR DEER RUN ROAD AND MILLSTONE ROAD, AND HAVING FIRST FLOOR ELEVATIONS RANGING FROM 3[±] FT TO 5[±] FT ABOVE THE STREAM, CONSTITUTE THE POTENTIAL IMPACT AREA IN CASE OF FAILURE OF THE SPECTACLE SWAMP DAM.

2. FAILURE AT SPECTACLE SWAMP DAM.

(1) CASE 1: SURCHARGE AT TOP OF DAM (EL. 585.5)

a. BREACH WIDTH

i. HEIGHT OF DAM: TOP OF DAM EL. 585.5

DAM DOWNSTREAM TOE EL. 564.5 (NATURAL STREAMBED), ∴ H = 21 FT

ii. DAM MID-HEIGHT EL. 575.0 (585.5 - 21/2 = 575.0)

iii. APPROXIMATE MID-HEIGHT LENGTH: $l \approx 115$ FT

(* FROM "NORWALK RIVER WATERSHED PROJECT", 1972)

iv. BREACH WIDTH (SEE NED-ACE DOWNSTREAM DAM FAILURE GUIDELINES)

$$W_b = 0.4 l = 0.4 \times 115 = 46 \text{ FT}$$

Project
Feature
ItemNDIP
SPECTACLE SWAMP DAMContract No. 2616-07
Designed MP
Checked EHRSheet 2-15
File No.
Date 12/19/80
Date 1/19/81b. PEAK FAILURE OUTFLOW (Q_{p1})

ASSUME SURCHARGE AT TOP OF DAM (EI. 585.5)

i. HEIGHT AT TIME OF FAILURE: $Y_0 = 21$ FTii. SPILLWAYS DISCHARGE AT TIME OF FAILURE (Q_0):1) PRINCIPAL SPILLWAY: $Q_{sp} = 102$ CFS2) EMERGENCY SPILLWAY: $Q_{se} = 1494$ CFS3) TOTAL DISCHARGE TO SPECTACLE BROOK: $Q_0 \approx 1596$ CFSiii. BREACH OUTFLOW (Q_b):

$$Q_b = \frac{8}{27} W_b \sqrt{g} Y_0^{3/2} = \frac{8}{27} \times 46 \times \sqrt{32.2} \times 21^{3/2} \approx 7445 \text{ CFS}$$

iv. PEAK FAILURE OUTFLOW (Q_{p1}) TO SPECTACLE BROOK
(BREACH DOES NOT INCLUDE SPILLWAYS)

$$Q_{p1} = Q_0 + Q_b = 1596 + 7445 \approx 9041 \text{ CFS}; \text{ ASSUME: } Q_{p1} = 9040 \text{ CF.}$$

c. FLOOD DEPTH IMMEDIATELY DOWNSTREAM FROM DAM:

$$Y = 0.44 Y_0 = 0.44 \times 21 \approx 9.2 \text{ FT}$$

d. ESTIMATE OF DOWNSTREAM FAILURE CONDITIONS AT POTENTIAL IMPACT

AREA (SEE NED-ACE GUIDELINES FOR ESTIMATING

DOWNSTREAM FAILURE HYDROGRAPHS):

i. REACH OF SPECTACLE BROOK BETWEEN THE DAM AND

IMPACT AREA:



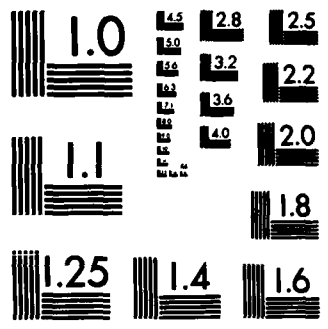

MICROCOPY RESOLUTION TEST CHART
NATIONAL BUREAU OF STANDARDS-1963-A

Project NDIP
 Feature SPECTACLE SWAMP DAM
 Item _____

Contract No. 2616-07 File No. _____
 Designed MP Date 12/19/80
 Checked EHS Date 1/19/81

THE (±) 700-FT-LONG REACH OF SPECTACLE BROOK FROM THE SPECTACLE SWAMP DAM TO THE INITIAL IMPACT AREA BETWEEN DEER RUN ROAD AND MILLSTONE ROAD IS APPROXIMATELY SHAPED AS SHOWN ON THE SKETCH BELOW:



THE AVERAGE SLOPE OF THE REACH IS (±) 0.5%.

ii. SPECTACLE RESERVOIR STORAGE AT TIME OF FAILURE:

CAPACITY OF RESERVOIR TO PRINCIPAL SPILLWAY CREST (E1.577.0):

$$S_1^* \approx 425 \text{ AC-FT}$$

CAPACITY OF RESERVOIR TO TOP OF DAM (E1.585.5):

$$S_2^* \approx 1194 \text{ AC-FT}$$

∴ STORAGE AT TIME OF FAILURE:

$$S_{MAX} = 1194 \text{ AC-FT}$$

* FROM "NORWALK RIVER WATERSHED PROJECT", 1972;
 SEE STAGE-STORAGE CURVES ON P. D-7

NOTE: THE ACE-US INVENTORY OF DAMS, DATED JAN. 24, 1979,

$$\text{GIVES } S_{MAX} = 809 \text{ AC-FT AND } S_{NORM} = 770 \text{ AC-FT.}$$

iii. PEAK INFLOW TO REACH: $Q_p = 3070 \text{ CFS}$



Project NDIP
 Feature SPECTACLE SWAMP DAM
 Item _____

Sheet D-17
 File No. _____
 Contract No. 264-C7
 Designed M.P. Date 12-2-51
 Checked E.P. N.Y. Date 11-2-51

iv. APPROXIMATE STAGE AT POTENTIAL IMPACT AREA FAILURE OF SPECTACLE

SWAMP DAM:

PREFAILURE STAGE: $Q_0 = 1596 \text{ CFS}$; $Y_0^* = 4.85 \text{ FT}$; $A_0^* = 270 \text{ FT}^2$;

$$\therefore V_0 = L A_0 = 700 \times 270 \approx 4.3 \text{ AC-FT}$$

* SEE STAGE-DISCHARGE CURVES ON P. D-18 ($n = 0.05$; $s = 0.005$)

FAILURE STAGE: $Q_p = 9040 \text{ CFS}$; $Y_1 = 9.6 \text{ FT}$; $A_1 = 1380 \text{ FT}^2$

$$\therefore V_1 = L(A_1 - A_0) = 700(1380 - 270) = 17.8 \text{ AC-FT} < \frac{S_{MAX}}{2}, \text{ OK}$$

$$Q_{p2} = Q_p \left(1 - \frac{V_1}{S_{MAX}}\right) = 9040 \left(1 - \frac{17.8}{119.4}\right) = 8905 \text{ CFS}$$

$$Y_2 = 9.55 \text{ FT}; A_2 = 1360 \text{ FT}^2; V_2 = 700(1360 - 270) = 17.5 \text{ AC-FT}; \bar{V} = \frac{V_1 + V_2}{2} = \frac{17.8 + 17.5}{2} = 17.65 \text{ AC}$$

$$\therefore Q_{p3} = 9040 \left(1 - \frac{17.65}{119.4}\right) = 8906 \text{ CFS}$$

ASSUME: REACH OUTFLOW $Q_{p3} \approx 8900 \text{ CFS}$; STAGE: $Y_3 = 9.6 \text{ FT}$

e. APPROXIMATE STAGE BEFORE FAILURE: $Q_0 = 1596 \text{ CFS}$; $Y \approx 4.8 \text{ FT}$

f. RAISE IN STAGE AT IMPACT AREA: $\Delta Y = Y_3 - Y = 9.6 - 4.8 = 4.8 \text{ FT}$

(2) CASE 2: SURCHARGE AT TEST FLOOD ELEVATION = PMF (EL. 584.5)

a. BREACH WIDTH

i. HEIGHT OF DAM: $H = \text{EL. } 584.5 - \text{EL. } 564.5 = 20 \text{ FT}$

ii. DAM MID-HEIGHT EL. 574.5

iii. APPROXIMATE MID-HEIGHT LENGTH: $L \approx 109 \text{ FT}$

* FROM "NORWALK RIVER WATERSHED PROJECT", 1972



Project NDIP
 Feature SPECTACLE SWAMP DAM
 Item _____

Contract No. 2616-07

File No. _____

Designed MP

Date 2/19/80

Checked EHB. DK

Date 11/9/81

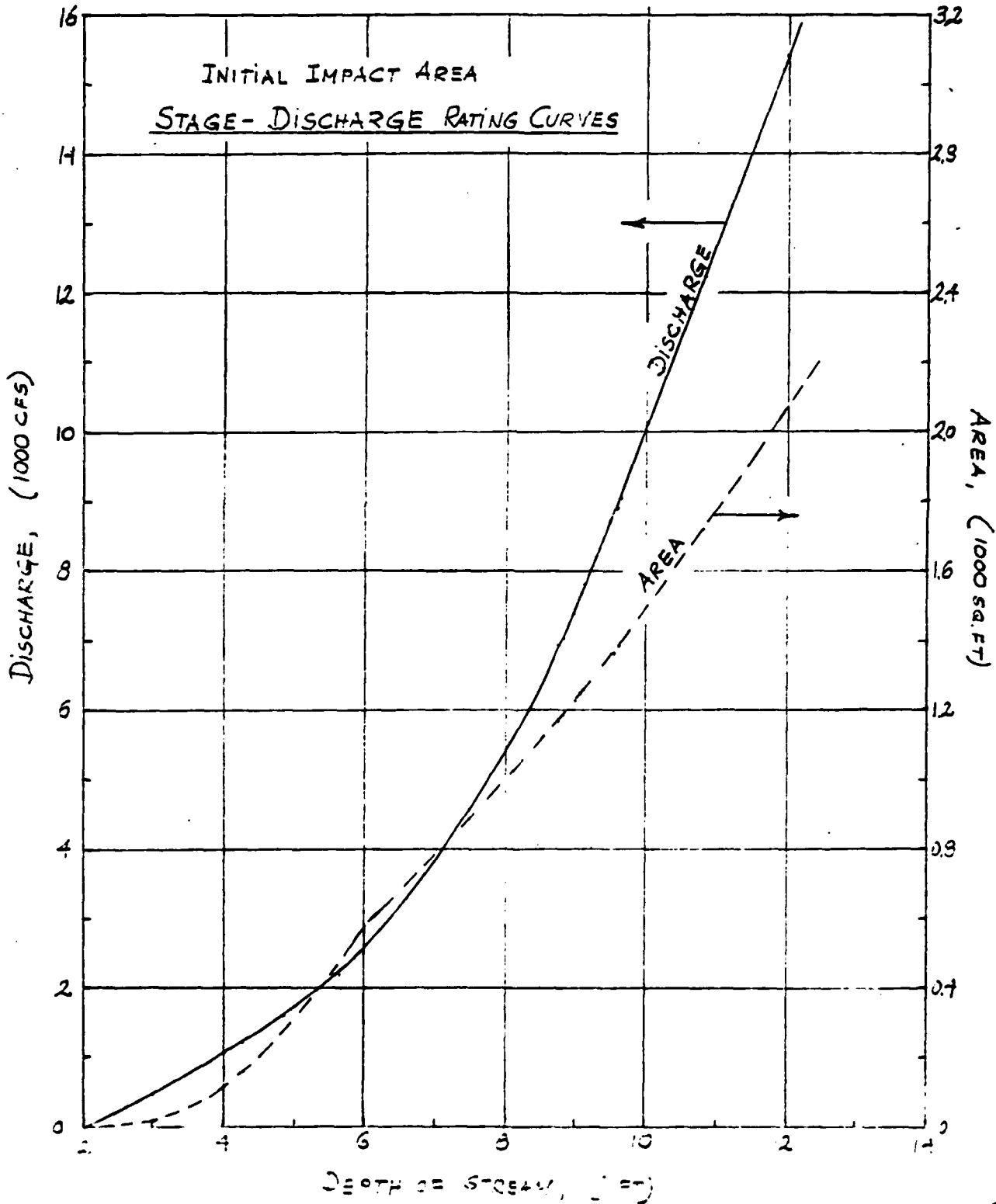

Project NDIP
 Feature SPECTACLE SHANE DAM
 Item _____

Sheet 3-9
 Contract No. 266-57 File No. _____
 Designed MIP Date '8-
 Checked EFF by _____ Date 11.2.81

IV. BREACH WIDTH $w_b = 0.4 L = 0.4 \times 109 = 43.6 \text{ FT}$

b. PEAK FAILURE OUTFLOW (Q_p)

i. HEIGHT AT TIME OF FAILURE: $Y_0 = 20 \text{ FT}$

ii. SPILLWAY DISCHARGE AT TIME OF FAILURE (Q_0):

1) PRINCIPAL SPILLWAY: $Q = 99 \text{ CFS}$

2) EMERGENCY SPILLWAY: $Q = 1134 \text{ CFS}$

3) TOTAL DISCHARGE TO SPECTACLE BROOK: $Q_0 = 1233 \text{ CFS}$

iii. BREACH OUTFLOW (Q_b):

$$Q_b = \frac{8}{27} \times 43.6 \times \sqrt{32.2} \times 20^{3/2} = 6557 \text{ CFS}$$

iv. PEAK FAILURE OUTFLOW TO SPECTACLE BROOK

$$Q_{p1} = Q_0 + Q_b = 1233 + 6557 = 7790 \text{ CFS}$$

c. FLOOD DEPTH IMMEDIATELY DOWNSTREAM FROM DAM

$$Y = 0.44 Y_0 = 0.44 \times 20 = 8.8 \text{ FT}$$

d. ESTIMATE OF DOWNSTREAM FAILURE CONDITIONS AT IMPACT AREA

i. PEAK INFLOW TO REACH: $Q_{p1} = 7790 \text{ CFS}$; $S_{MAX} = 1062 \text{ AC-FT}$ (SEE P. D-7)

ii. APPROXIMATE STAGE AT IMPACT AREA

PREFAILURE STAGE: $Q_0 = 1223 \text{ CFS}$; $Y_0^* = 4.3 \text{ FT}$; $A_0^* = 160 \text{ FT}^2$

$$\therefore V_0 = 700 + 160 = 2.6 \text{ AC-FT}$$

* SEE STAGE-DISCHARGE CURVES ON P. D-18 ($n=0.05$; $s=0.005$)

Project NDJP
 Feature SPECTACLE SHAMP DAM
 Item _____

Contract No. 2616-C7 File No. _____
 Designed MP Date 12/9/80
 Checked EHB 13 Date 1/19/81

FAILURE STAGE: $Q_{p1} = 7790 \text{ CFS}$; $y_1 = 9.1 \text{ FT}$; $A_1 = 1260 \text{ FT}^2$

$$\therefore V_1 = 700(1260 - 160) = 17.7 \text{ AC-FT} < \frac{S_{\text{max}}}{2}, \text{ OK}$$

$$Q_{p2} = 7790 \left(1 - \frac{17.7}{1062}\right) = 7660 \text{ CFS}$$

$$y_2 = 9.05 \text{ FT}; A_2 = 1235 \text{ FT}^2; V_2 = 700(1235 - 160) = 17.3 \text{ AC-FT}; \bar{V} = \frac{17.7 + 17.3}{2} = 17.5 \text{ AC-FT}$$

$$\therefore Q_{p3} = 7790 \left(1 - \frac{17.5}{1062}\right) = 7761 \text{ CFS};$$

ASSUME: REACH OUTFLOW $Q_{p3} \approx 7760 \text{ CFS}$; STAGE: $y_3 \approx 9.05 \text{ FT}$

e. APPROXIMATE STAGE BEFORE FAILURE: $Q_0 = 1223 \text{ CFS}$; $y \approx 4.3 \text{ FT}$

f. RAISE IN STAGE AT IMPACT AREA: $\Delta y = y_3 - y = 9.05 - 4.3 = 4.75 \text{ FT}$

III. SELECTION OF TEST FLOOD

1. CLASSIFICATION OF DAM ACCORDING TO NED-ACE GUIDELINES:

a. SIZE: STORAGE (MAX)* = 1194 AC-FT (1000 < S < 50,000 AC-FT)

HEIGHT* = 21 FT (H < 25 FT)

* NOTE: STORAGE (SEE P. D-12); HEIGHT (SEE P. D-10)

\therefore SIZE CLASSIFICATION: INTERMEDIATE.



Project ND-0
 Feature SPECTACLE SWAMP DAM
 Item _____

Sheet 2-21
 File No. _____
 Contract No. 2616-07
 Designed W.F. Date 12-4-60
 Checked E.H.B. Date 1/19/61

b. HAZARD POTENTIAL: THIS DAM HAS A HIGH HAZARD POTENTIAL DUE TO PROJECTED DOWNSTREAM IMPACT CAUSED BY THE FAILURE OF SPECTACLE SWAMP DAM.

∴ HAZARD POTENTIAL: HIGH

2. TEST FLOOD: PMF = 2700 CFS

THIS SELECTION IS MADE ON THE RESULTS OF THE PREVIOUS ANALYSIS AND CLASSIFICATION.

IV. SUMMARY

1. TEST FLOOD: PMF = 2700 CFS

(PARALLEL COMPUTATIONS HAVE BEEN MADE FOR $\frac{1}{2}$ PMF = 1350 CFS).

2. PERFORMANCE AT PEAK FLOOD CONDITION:

a. PEAK INFLOW: $Q_{p1} = \text{PMF} = 2700 \text{ CFS}$

b. PEAK OUTFLOW: $Q_{p3} = 1210 \text{ CFS AT NORM. POOL EL. 577}$ ($Q_{p3}^I = 700 \text{ CFS AT NORM. POOL EL. 570}$)

c. SPILLWAY CAPACITY:

i. SPILLWAY CAPACITY TO EMERGENCY SPILLWAY EI. 578.0:

$H = 1 \text{ FT}; Q = 78 \text{ CFS OR } 6\% \text{ OF } Q_{p3} \text{ (OR } 11\% \text{ OF } Q_{p3}^I)$





Project NDIP
 Feature SPECTACLE SWAMP DAM
 Item _____

Sheet D-22
 Contract No. 2616-07 File No. _____
 Designed MIP Date 12/19/80
 Checked EKB 0 Date 1/19/81

ii. SPILLWAY CAPACITY TO TOP OF DAM EL. 585.5 (TOTAL OF BOTH SPILLWAYS)

$$H = 8.5 \text{ CFS}; Q = 1596 \text{ CFS OF } 132\% \text{ OF } Q_{p3} \text{ (OF } 228\% \text{ OF } Q_{p3}^T)$$

THEREFORE, AT TEST FLOOD $Q_{p1} = \text{PMF}$

THE DAM IS NOT OVERTOPPED.

3. DOWNSTREAM FAILURE CONDITIONS.

a. PEAK FAILURE OUTFLOW:

$$Q = 9940 \text{ CFS, SURCHARGE ELEVATION AT TOP OF DAM (EL. 585.5):}$$

$$Q' = 7040 \text{ CFS, SURCHARGE ELEVATION AT TEST FLOOD POOL (EL. 584.5)}$$

b. FLOOD DEPTH IMMEDIATELY DOWNSTREAM FROM DAM:

$$y_0 = 9.2 \text{ FT (AT SURCHARGE EL. 585.5) OR}$$

$$y_0' = 8.8 \text{ FT (AT SURCHARGE EL. 584.5)}$$

c. CONDITIONS AT THE INITIAL IMPACT AREA DOWNSTREAM FROM DAM

(SPECTACLE BROOK):

i. APPROXIMATE STAGE BEFORE FAILURE: $y = 4.8 \text{ FT (AT SURCHARGE EL. 585.5)}$
 OR $y' = 4.3 \text{ FT (AT SURCHARGE EL. 584.5)}$

ii. APPROXIMATE STAGE AFTER FAILURE: $y_3 = 9.6 \text{ FT (AT SURCHARGE EL. 585.5) OR}$
 $y_3' = 9.05 \text{ FT (AT SURCHARGE EL. 584.5)}$

iii. RAISE IN STAGE AT IMPACT AREA: $\Delta y = 4.8 \text{ FT (AT SURCHARGE EL. 585.5) OR}$
 $\Delta y' = 4.75 \text{ FT (AT SURCHARGE EL. 584.5)}$



APPENDIX E

INFORMATION AS CONTAINED IN THE

NATIONAL INVENTORY OF DAMS

NOT AVAILABLE AT THIS TIME

END

FILMED

10-84

DTIC