

MICROCOPY RESOLUTION TEST CHART
NATIONAL BUREAU OF STANDARDS-1963-A



HAMMONASSET RIVER BASIN
MADISON/KILLINGWORTH, CONNECTICUT

HAMMONASSET RESERVOIR DAM
CT. 00400

AD-A144 727

PHASE I INSPECTION REPORT
NATIONAL DAM INSPECTION PROGRAM

DTIC FILE COPY



DTIC
ELECTED
S AUG 27 1984 D

DEPARTMENT OF THE ARMY
NEW ENGLAND DIVISION, CORPS OF ENGINEERS
WALTHAM, MASS. 02154

84 08 20 070
SEPTEMBER 1978

DISTRIBUTION STATEMENT A
Approved for public release
Distribution Unlimited

UNCLASSIFIED

SECURITY CLASSIFICATION OF THIS PAGE (When Data Entered)

REPORT DOCUMENTATION PAGE		READ INSTRUCTIONS BEFORE COMPLETING FORM
1. REPORT NUMBER CT 00400	2. GOVT ACCESSION NO. AD-A144 727	3. RECIPIENT'S CATALOG NUMBER
4. TITLE (and Subtitle) Hammonasset Reservoir Dam NATIONAL PROGRAM FOR INSPECTION OF NON-FEDERAL DAMS		5. TYPE OF REPORT & PERIOD COVERED INSPECTION REPORT
		6. PERFORMING ORG. REPORT NUMBER
7. AUTHOR(s) U.S. ARMY CORPS OF ENGINEERS NEW ENGLAND DIVISION		8. CONTRACT OR GRANT NUMBER(s)
9. PERFORMING ORGANIZATION NAME AND ADDRESS		10. PROGRAM ELEMENT, PROJECT, TASK AREA & WORK UNIT NUMBERS
11. CONTROLLING OFFICE NAME AND ADDRESS DEPT. OF THE ARMY, CORPS OF ENGINEERS NEW ENGLAND DIVISION, NEDED 424 TRAPELO ROAD, WALTHAM, MA. 02254		12. REPORT DATE September 1978
		13. NUMBER OF PAGES 55
14. MONITORING AGENCY NAME & ADDRESS (if different from Controlling Office)		15. SECURITY CLASS. (of this report) UNCLASSIFIED
		15a. DECLASSIFICATION/DOWNGRADING SCHEDULE
16. DISTRIBUTION STATEMENT (of this Report) APPROVAL FOR PUBLIC RELEASE: DISTRIBUTION UNLIMITED		
17. DISTRIBUTION STATEMENT (of the abstract entered in Block 20, if different from Report)		
18. SUPPLEMENTARY NOTES Cover program reads: Phase I Inspection Report, National Dam Inspection Program; however, the official title of the program is: National Program for Inspection of Non-Federal Dams; use cover date for date of report.		
19. KEY WORDS (Continue on reverse side if necessary and identify by block number) DAMS, INSPECTION, DAM SAFETY, Hammonasset River Bas Madison/Killingworth, Connecticut		
20. ABSTRACT (Continue on reverse side if necessary and identify by block number) The Hammonasset Reservoir Dam is a concrete dam that is 447 feet long with a 163 foot spillway. It has an intake structure with a 36 inch blowoff and gates. Based on visual inspection, records available and past operational performance, the dam is judged to be in good condition. The project will pass 75.8 percent of the PMF before overtopping the dam.		



DEPARTMENT OF THE ARMY
NEW ENGLAND DIVISION, CORPS OF ENGINEERS
424 TRAPELO ROAD
WALTHAM, MASSACHUSETTS 02154

REPLY TO
ATTENTION OF

NEDED

Honorable Ella T. Grasso
Governor of the State of Connecticut
State Capitol
Hartford, Connecticut 06115

NOV 1968

Dear Governor Grasso:

I am forwarding to you a copy of the Hammonasset Reservoir Dam Phase I Inspection Report, which was prepared under the National Program for Inspection of Non-Federal Dams. This report is presented for your use and is based upon a visual inspection, a review of the past performance and a brief hydrological study of the dam. A brief assessment is included at the beginning of the report. I have approved the report and support the findings and recommendations described in Section 7 and ask that you keep me informed of the actions taken to implement them. This follow-up action is a vitally important part of this program.

A copy of this report has been forwarded to the Department of Environmental Protection, the cooperating agency for the State of Connecticut. In addition, a copy of the report has also been furnished the owner, the New Haven Water Company, 90 Sargeant Drive, New Haven, Connecticut, 06511, ATTN: Mr. Jack Reynolds, Superintendent Source of Supply.

Copies of this report will be made available to the public, upon request, by this office under the Freedom of Information Act. In the case of this report the release date will be thirty days from the date of this letter.

I wish to take this opportunity to thank you and the Department of Environmental Protection for your cooperation in carrying out this program.

Sincerely yours,

JOHN P. CHANDLER
Colonel, Corps of Engineers
Division Engineer

Incl
As stated

Accession For	
NTIS GRA&I	<input checked="" type="checkbox"/>
DTIC TAB	<input type="checkbox"/>
Unannounced	<input type="checkbox"/>
Justification	
By	
Distribution/	
Availability Codes	
Dist	Avail and/or Special
AI	

HAMMONASSET RESERVOIR DAM

CT 00400

HAMMONASSET RIVER BASIN
MADISON/KILLINGWORTH, CONNECTICUT

PHASE I INSPECTION REPORT
NATIONAL DAM INSPECTION PROGRAM

DTIC
ELECTE
S AUG 27 1984 D

DISTRIBUTION STATEMENT
Approved for public release;
Distribution Unlimited

NATIONAL DAM INSPECTION PROGRAM

PHASE I INSPECTION REPORT

Identification Number: CT 00400
Name: Hammonasset Reservoir Dam
Town: Madison/Killingworth
County & State: New Haven/Middlesex County,
Connecticut
Stream: Hammonasset River
Date of Inspection: August 1, 1978

BRIEF ASSESSMENT

The Hammonasset Reservoir Dam is a concrete dam that is 447 feet long with a 163 foot spillway. It has an intake structure with a 36 inch blowoff and gates.

Based on the visual inspection, records available and past operational performance, the dam is judged to be in good condition. There are areas of the dam which should be studied in order to monitor its behavior such as, the downstream side which shows signs of seepage at the junction of the rock and the dam as well as some of the expansion and contraction joints.

The project will pass 75.8 percent of the Probable Maximum Flood (PMF) (recommended spillway design flood) before overtopping the dam. However the spillway capacity is not judged seriously inadequate because the water will flow only 1.15 feet over a concrete non-overflow section.

Recommended measures to be undertaken by the owner include monitoring seepage and establishing an inspection program. The owner shall implement the recommendations and remedial measures described in Section 7 within two to three years after receipt of this Phase I Inspection Report.

Joseph F. Merluzzo
Connecticut P.E. #7639
Project Manager

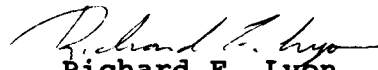
Richard F. Lyon
Connecticut P.E. #8443
Project Engineer

This Phase I Inspection Report on the Hammonasset Reservoir Dam has been reviewed by the undersigned Review Board members. In our opinion, the reported findings, conclusions, and recommendations are consistent with the Recommended Guidelines for Safety Inspection of Dams, and with good engineering judgment and practice, and is hereby submitted for approval.



CHARLES G. TIERSCH, Chairman
Chief, Foundation and Materials Branch
Engineering Division



FRED J. RAVENS, Jr., Member
Chief, Design Branch
Engineering Division



SAUL COOPER, Member
Chief, Water Control Branch
Engineering Division

APPROVAL RECOMMENDED:

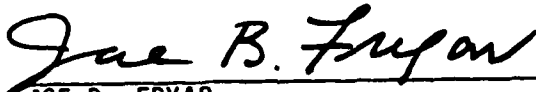

JOE B. FRYAR
Chief, Engineering Division

PREFACE

This report is prepared under guidance contained in the Recommended Guidelines for Safety Inspection of Dams, for Phase I Investigations. Copies of these guidelines may be obtained from the Office of Chief of Engineers, Washington, D.C. 20314. The purpose of a Phase I Investigation is to identify expeditiously those dams which may pose hazards to human life or property. The assessment of the general condition of the dam is based upon available data and visual inspections. Detailed investigations and analyses involving topographic mapping, subsurface evaluations, testing, and detailed computational evaluations are beyond the scope of a Phase I Investigation; however, the investigation is intended to identify the need for such studies.

In reviewing this report, it should be realized that the reported condition of the dam is based on observations of field conditions at the time of inspection along with data available to the inspection team. In cases where the reservoir was lowered or drained prior to inspection, such action, while improving the stability and safety of the dam, removes the normal load on the structure and may obscure certain conditions which might otherwise be detectable if inspected under the normal operating environment of the structure.

It is important to note that the condition of a dam depends on numerous and constantly changing internal and external conditions, and is evolutionary in nature. It would be incorrect to assume that the present condition of the dam will continue to represent the condition of the dam at some point in the future. Only through continued care and inspection can there be any chance that unsafe conditions be detected.

Phase I Inspections are not intended to provide detailed hydrologic and hydraulic analyses. In accordance with the established Guidelines, the Spillway Test Flood is based on the estimated "Probable Maximum Flood" for the region (greatest reasonably possible storm runoff), or fractions thereof. Because of the magnitude and variety of such a storm event, a finding that a spillway will not pass the test flood should not be interpreted as necessarily posing a highly inadequate condition. The test flood provides a measure of relative spillway capacity and serves as an aide in determining the need for more detailed hydrologic and hydraulic studies, considering the size of the dam, its general condition and the downstream damage potential.

TABLE OF CONTENTS

	<u>Page</u>
LETTER OF TRANSMITTAL	
BRIEF ASSESSMENT	i
BRIEF ASSESSMENT	ii
REVIEW BOARD PAGE	iii
PREFACE	iv
TABLE OF CONTENTS	v
TABLE OF CONTENTS	vi
OVERVIEW PHOTO	
LOCATION MAP	vii
REPORT	
SECTION 1 - PROJECT INFORMATION	
1.1 General	1
1.2 Description of Project	2
1.3 Pertinent Data	3
SECTION 2 - ENGINEERING DATA	
2.1 Design	7
2.2 Construction	7
2.3 Operation	7
2.4 Evaluation	7
SECTION 3 - VISUAL INSPECTION	
3.1 Findings	9
3.2 Evaluation	11
SECTION 4 - OPERATIONAL PROCEDURES	
4.1 Procedures	12
4.2 Maintenance of Dam	12
4.3 Maintenance of Operating Facilities	12
4.4 Description of Warning System	13
4.5 Evaluation	13

TABLE OF CONTENTS (CONTINUED)

	<u>Page</u>
SECTION 5 - HYDRAULIC/HYDROLOGIC	
5.1 Evaluation of Features	14
SECTION 6 - STRUCTURAL STABILITY	
6.1 Evaluation of Structural Stability	15
SECTION 7 - ASSESSMENT, RECOMMENDATIONS & REMEDIAL MEASURES	
7.1 Dam Assessment	17
7.2 Recommendations	17
7.3 Remedial Measures	19
<u>APPENDIX MATERIALS</u>	
A VISUAL INSPECTION CHECK LIST	A-1 to A-8
B LIST OF REFERENCES	B-1
GENERAL PLAN	Plate 1
SECTION AND DETAILS	Plate 2
C PHOTO LOCATION PLAN	Plate 3
PHOTOGRAPHS	II-1 to II-4
D HYDRAULIC COMPUTATIONS	D-1 to D-7
REGIONAL VICINITY MAP	Plate 4
E INFORMATION AS CONTAINED IN THE NATIONAL INVENTORY OF DAMS	

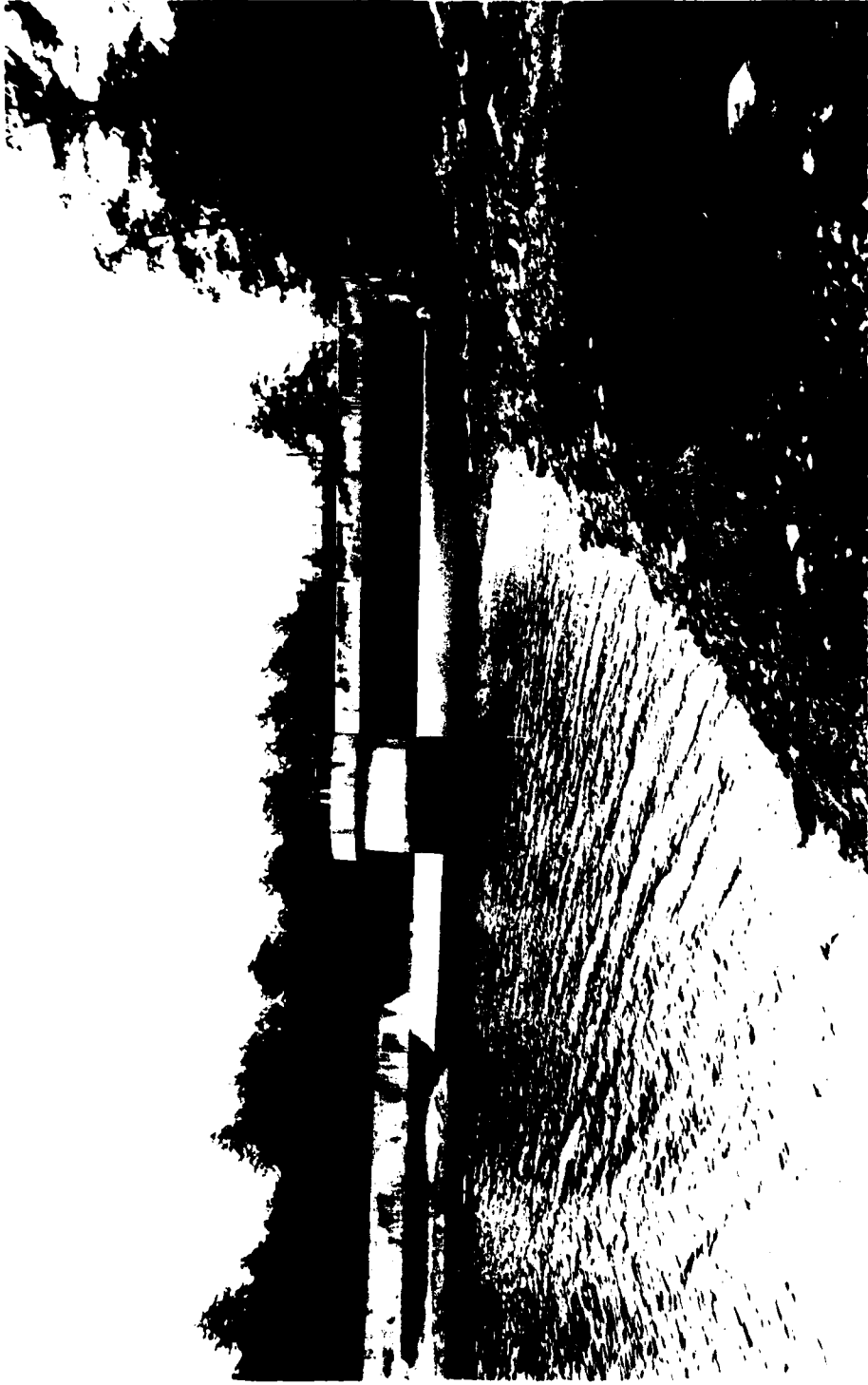

OVERVIEW PHOTO

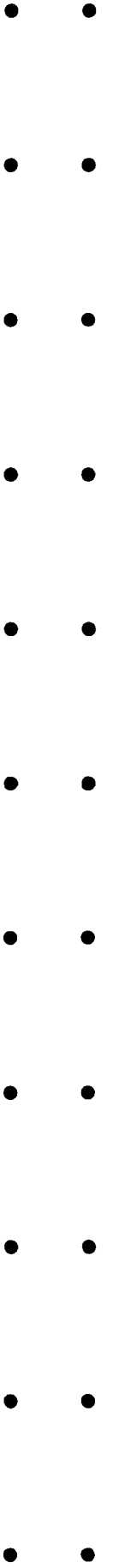

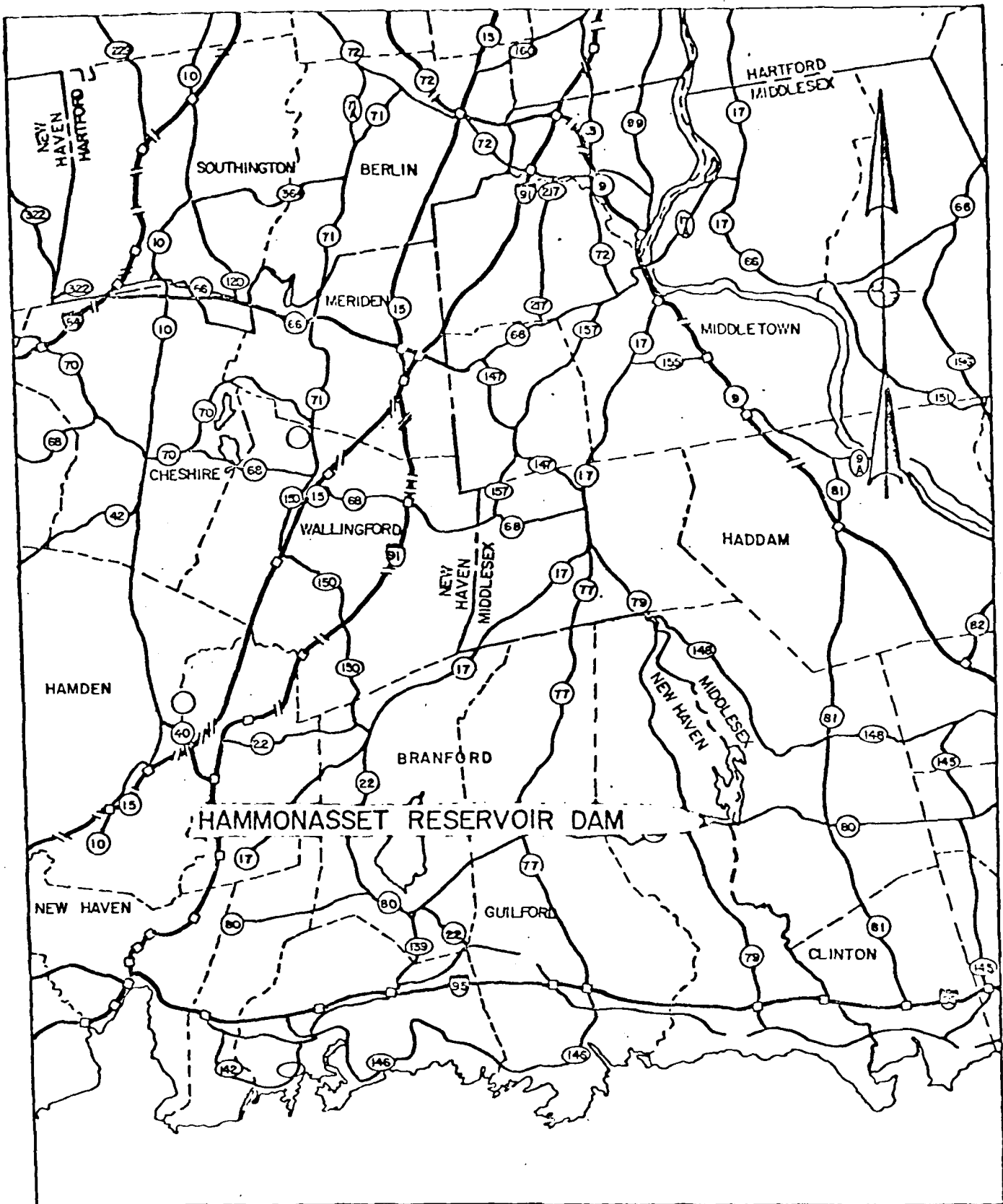

U.S. ARMY, CORPS OF ENGINEERS
 NEW ENGLAND DIVISION
 WALTHAM, MASS.

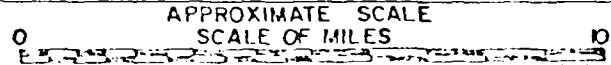

LOCATION MAP

PHASE I INSPECTION REPORT
HAMMONASSETT RESERVOIR DAM

SECTION 1 - PROJECT INFORMATION

1.1 General

a. Authority - Public Law 92-367, August 8, 1972 authorized the Secretary of the Army, through the Corps of Engineers, to initiate a National Program of Dam Inspection throughout the United States. The New England Division of the Corps of Engineers has been assigned the responsibility of supervising the inspection of dams within the New England Region. Storch Engineers has been retained by the New England Division to inspect and report on selected dams in the State of Connecticut. Authorization and notice to proceed were issued to Storch Engineers under a letter of May 3, 1978 from Ralph T. Garver, Colonel, Corps of Engineers. Contract No. DACW33-78-C-0000 has been assigned by the Corps of Engineers for this work.

b. Purpose -

(1) Perform technical inspection and evaluation of non-Federal dams to identify conditions which threaten the public safety and thus permit correction in a timely manner by non-Federal interests.

(2) Encourage and prepare the states to initiate quickly, effective dam safety programs for non-Federal dams.

(3) To update, verify and complete the National Inventory of Dams.

1.2 Description of Project

The Hammonasset Reservoir Dam is owned by the New Haven Water Company of New Haven County, Connecticut. It is located on the borders of the Towns of Madison and Killingworth (See Location Map), and is on the Hammonasset River. The water from this dam is used to supplement the supply of Lake Gaillard which is located approximately 10 miles due west.

This structure is a 163 foot long combination concrete gravity-dam spillway with concrete dike walls located on the east side of the dam. It has an intake well with a 36 inch diameter blowoff line which is used to control the downstream flow.

The size classification of the dam is intermediate (50 feet high and 8,330 acre-feet of storage) and the hazard classification is high per the criteria set forth in the Recommended Guidelines for Safety Inspection of Dams by the Corps of Engineers. The failure of the dam would result in the inundation of several residential and commercial dwellings downstream. The approximate limits are shown on the Regional Vicinity Map which is located in Appendix D.

The dam was designed in 1955 by Malcolm Pirnie, Consultant Engineer, White Plains, New York. Construction was completed in 1956. The original site where the dam is now located used to have a natural water fall. The dam is designed to be relatively free from maintenance.

The person in charge of day to day operation of the dam is Norman Paluba, New Haven Water Company, New Haven, Connecticut, Telephone Number: 624-6671.

1.3 Pertinent Data

a. Drainage Area - A 19.5 square mile drainage area contributes to the dam. The terrain is rolling with mixed amounts of farm land, orchards and residential development.

b. Discharge at Damsite - The maximum known spillway discharge (from high water marks) was approximately 1,000 cfs. Date of this discharge is not known.

(1) Outlet works: size 36 inch at invert elevation 219.5.

(2) Maximum know flood at damsite: 1,000 cfs.

(3) Ungated spillway capacity at maximum pool elevation: 14,385 cfs at 278 elevation.

(4) Gated spillway capacity at pool elevation: N/A cfs at N/A elevation.

(5) Gated spillway capacity at maximum pool elevation: N/A cfs at N/A elevation.

(6) Total spillway capacity at maximum pool elevation:
14,385 cfs at 278 elevation.

c. Elevation (Feet above MSL)

- (1) Top of of dam: 278.0
- (2) Maximum pool-design surcharge: 278
- (3) Full flood-control pool: N/A
- (4) Recreation pool: N/A
- (5) Spillway crest: 270.0
- (6) Upstream portal, invert diversion tunnel: 219.5
- (7) Streambed at centerline of dam: 217.75
- (8) Maximum tailwater: 223.0

d. Reservoir

- (1) Length of maximum pool: 10,000 ± feet
- (2) Length of recreation pool: N/A
- (3) Length of flood-control pool: N/A

e. Storage (Acre-Feet)

- (1) Recreation pool: N/A
- (2) Flood-control pool: N/A
- (3) Design surcharge: 8,330
- (4) Top of dam: 8,330

f. Reservoir Surface (Acres)

- (1) Top of dam: 410
- (2) Maximum pool: 410
- (3) Flood-control pool: N/A
- (4) Recreation pool: N/A
- (5) Spillway crest: 310

g. Dam

- (1) Type: concrete - gravity
- (2) Length: 447 feet +
- (3) Height: 50 feet +
- (4) Top width: 2 feet +
- (5) Side Slopes: N/A
- (6) Zoning: N/A
- (7) Impervious Core: N/A
- (8) Cutoff: 10 feet +
- (9) Grout curtain: none
- (10) Other: N/A

h. Diversion and Regulating Tunnel

- (1) Type: cast iron
- (2) Length: 85 feet +
- (3) Closure: N/A
- (4) Access: None
- (5) Regulating Facilities: manually operated
gate valves -
(36" blowoff)

i. Spillway

- (1) Type: concrete fixed weir
- (2) Length of weir: 163 feet
- (3) Crest elevation: 270
- (4) Gates: None
- (5) U/S Channel: underwater

(6) D/S Channel: natural channel

(7) General: N/A

j. Regulating Outlets

Regulating outlets consist of a single, 36 inch blowoff for the purpose of a compensating water supply for riparian owners.

(1) Invert: 219.5

(2) Size: 36 inch

(3) Description: cast iron

(4) Control Mechanism: manually operated
gate valve

(5) Other: N/A

SECTION 2 - ENGINEERING DATA

2.1 Design

The design information is in the form of as-built contract drawings prepared by Malcolm Pirnie Engineers dated March, 1957. Other design information was not available because of the recent move of the headquarters of the New Haven Water Company. A telephone call to Malcolm Pirnie Engineers, Consultant Engineer for this project, determined that designs are available for the capacity-discharge curves, hydrology, structural design of the intake chamber and several stability checks for sliding.

2.2 Construction

The dam was constructed in 1956. Besides the contract plans, there was no other information available, such as photographs, about the construction period.

2.3 Operation

The operation of the blowoff for the dam is manual. There is no data or operating procedure that has been established for its operation.

2.4 Evaluation

a. Availability - The construction drawings were readily available, however, the design by Malcolm Pirni, Inc. could not be located. The dam has no operating procedures.

b. Adequacy - The information that was made available was only a minor factor in the assessment, which was based mainly on the visual inspection, past performance history and hydrologic and hydraulic assumptions.

c. Validity - The construction drawings are accurate to the extent that the visible inspection did not reveal any new features.

SECTION 3 - VISUAL INSPECTION

3.1 Findings

a. General - The visual inspection was conducted on August 1, 1978 by members of the engineering staff of Storch Engineers, with the help of Norman Paluba of the New Haven Water Company. A copy of the visual inspection check list is contained in Appendix A of this report.

The following procedure was used:

1. Inspection of the upstream area of the dam for cracks, shifting of the rock or evidences of erosion.
2. Visual survey of the crest and face for cracks and seepage at construction and expansion joints.
3. Check for seepage at interface between the rock and the concrete of the dam.
4. Measurement of the temperature of the seepage water, water in the reservoir and water downstream.
5. Check of the structural condition of the intake well and the bridge leading to it.
6. Observation of the downstream channel for boulders, branches, loose rocks and overhanging trees.
7. Photographs were taken of the general view of the dam and its appurtenant structures, (Appendix C, Plate 3) as well as other items that were given attention during the inspection.

Before the inspection, the design and construction plans were studied. A compact sketch of the dam and its surrounding area was made for use during the period of inspection (Appendix B, Plate 1).

In general, the condition of the dam and its appurtenant structures is good.

b. Dam - The crest and the downstream face of the spillway showed no visible cracks. A small amount of seepage was observed at two places on the downstream face (Appendix C, Photos 1, 7 and 8) as well as a steady flow from the interface of the dam and the ledge (Appendix C, Photo 6). The general condition of the body of the dam was good. On the apron at the toe of the dam is a metering weir with a gauge so that minimum flows can be controlled by means of the valves in the intake well.

c. Appurtenant Structures - The intake well has a valve operator for a 36 inch blowoff which can control the level of the reservoir. The valves were underwater but appeared to be in good condition and functioning properly. The visible concrete of the intake well appeared to be in good condition with no evidences of any significant cracks or spalling. The bridge out to the intake well had areas (Appendix C, Photo 3) that were spalled and weathered but in general was in good condition. There were no evidences that the intake well or the bridge and its abutment had experienced any settlement.

d. Reservoir Area - An inspection of the immediate upstream area showed no evidence of any movement of the adjacent embankment. A high water mark approximately 18 inches above the crest of the spillway was observed on the west abutment. The training wall that is on the east side of the dam is a gravity section and is in good condition with no signs of movement, cracking or spalling.

e. Downstream Channel - The dam was cut into rock at the same site that a natural waterfall had once been. The channel itself is in a fairly natural state with many large boulders and trees. Immediately downstream (400' +) is a large concrete arch bridge (Appendix C, Photo 5). The waterway opening is very large and appears to be adequate hydraulically.

3.2 Evaluation

The visual inspection revealed no apparent areas of distress in the concrete. The observations did show some seepage between the rock-concrete interface and the construction joints, however, this is not detrimental to the safety of the dam. Overall, the general condition of the dam is good.

SECTION 4 - OPERATIONAL PROCEDURES

4.1 Procedures

The responsibility of maintenance is with the New Haven Water Company. There are approximately 2-3 men that work at the site, although they may receive or give assistance to other dams in the area as required.

The access to the intake well and its attached equipment has been protected from vandals by the use of gates and chains (Appendix C, Photo 3). The purpose of the valve to the blowoff line is so the minimum flow downstream can be maintained. There is no written or formal operating procedure to control the reservoir for purposes of flood control. The water level is quite often several feet below the spillway crest, because of the demand to supplement water at Lake Gaillard.

4.2 Maintenance of Dam

The dam was designed so that its maintenance would be minimal. Since the completion of construction in 1956 the only maintenance regularly performed is to keep the access way to the site clear.

4.3 Maintenance of Operating Facilities

Except for paint, the operating equipment is as installed during the original construction. The valve operators on top of the intake well are chained in one position so that vandals cannot open or close the sluice gate.

4.4 Description of Warning System

There is no warning system in effect.

4.5 Evaluation

In view of the simplicity of the operation, the maintenance of the dam and its operating equipment seems adequate.

SECTION 5 - HYDRAULIC/HYDROLOGIC

5.1 Evaluation of Features

a. Design Data - The 163 foot spillway and the 36 inch diameter blowoff are the only means of transmitting water past the dam. Under conditions of the Probable Maximum Flood (PMF), the spillway will carry a major portion of the flow.

Using the guide curves supplied by the Corps of Engineers (rolling), the PMF inflow is 28,275 cfs and the routed outflow is 18,975 cfs. The pond elevation at the PMF is 279.15 or 1.15 feet over the top of the dam. The spillway design flood is 14,285 cfs or 75.8 percent of the PMF.

b. Experience Data - The Hammonasset Reservoir Dam was built after all the major floods of this century and, therefore, did not experience any of them. A high water mark on the spillway abutment indicates a maximum high water of approximately 18 inches over the spillway or 1,000 cfs.

c. Visual Observations - The spillway channel which is a natural channel is in good condition.

d. Overtopping Potential - Calculations by Storch Engineers indicate that the PMF will overtop the dam by 1.15 feet.

SECTION - 6 STRUCTURAL STABILITY

6.1 Evaluation and Structural Stability

a. Visual Observations - There are no routine inspections conducted by the resident staff, however, maintenance workers at the dam site operate the sluice gates on the intake well simultaneously with the monitoring of the spillway and the downstream area.

The inspection did not reveal any significant damage to the dam and appurtenant structures, nor did it reveal unusual phenomena in the immediate dam area. It is concluded that the dam appears structurally stable.

b. Design and Construction Data - The design and construction data available were the original construction drawings, hydrological data and oral information.

The structural stability analysis of Malcolm Pirnie Engineers assumed the following:

1. Maximum flood line elevation - 277.0 feet;
2. Ice thrust from a two foot thickness of ice;
3. Uplift pressure at the base of the dam that varies from $3/4$ of full reservoir pressure to zero at the tail water side of the dam;
4. Coefficient of sliding friction factor between concrete and rock equal to 0.7;
5. Unit weight of concrete equal to 150 pounds per cubic foot.

Design computations indicated adequate structural stability for all combinations of these loads. These calculations were not available for review.

c. Operating Records - The water level in the reservoir is measured daily.

d. Post Construction Changes - The dam has not undergone any post construction changes since the completion of construction in 1956.

e. Seismic Stability - The dam is located in Seismic Zone No. 1 and in accordance with recommended Phase I Guidelines does not warrant seismic analysis.

SECTION 7 - ASSESSMENT, RECOMMENDATIONS & REMEDIAL MEASURES

7.1 Dam Assessment

a. Condition - After study of the available documents, the results of this inspection and meetings with resident staff persons, the conclusion is that the general condition of the Hammonasset Dam is good. There is no cause to doubt the structural stability and concrete durability of this dam, however, there are some recommendations that are listed in Section 7.2 that will improve its condition.

b. Adequacy of Information - The assessment of the condition of the dam can be based on the information available as well as the visual inspection.

c. Urgency - The owner shall implement the recommendations within two to three years after receipt of this Phase I Inspection Report.

d. Need for Additional Investigation - Taking into account the results of this inspection, additional observations for this dam should be undertaken.

Primary attention should be given to determine the reason for seepage at the junction of the rock ledge with the west wing of the dam.

7.2 Recommendations

It is recommended that the following actions be undertaken by the owner:

1. Instrument observations should be implemented at the leaking construction and expansion joints on the downstream face of the dam and at the junction of the rock ledge with its west wing. Seepage should be checked in dry weather after the apron of the spillway has been drained.
2. The following meterings and observations should be made:
 - (a.) Seepage discharges, monthly or quarterly, arrangements for measurement of seepage should be commenced;
 - (b.) Seepage water temperature, simultaneously with the measurement of seepage discharges;
 - (c.) Chemical analyses of the reservoir and seepage water, simultaneously with measurement of seepage discharges, yearly. The water should be checked for pH, hardness, Ca, Mg, CO_3 , HCO_3 , Na+K, and CO_2 ;
 - (d.) Sketches and photographs of the damaged surfaces of the crest, upstream and downstream slopes of the spillway, dike and abutments and the exterior faces of the service bridge, yearly.
3. Develop a systematic inspection program during periods of the highest and lowest reservoir levels.

A dry spillway apron should be achieved for this inspection to assure that all features of the dam are evaluated.

7.3 Remedial Measures

It is considered important that the following items be attended to as early as practical.

- a. Alternatives - Not applicable.
- b. O & M Maintenance and Procedures -
 1. Grass, brush and trees on the downstream area around the dam for a distance of 30 feet from its toe should be removed to facilitate the visual observation and evaluation of existing and potential seepage.
 2. The downstream spillway channel should be cleaned of loose materials, stones, brush and trees.
 3. Surface deteriorations of concrete on the service bridge, west abutment and crest of the spillway should be repaired.

APPENDIX A

VISUAL INSPECTION CHECK LIST A-1 to A-8

VISUAL INSPECTION CHECK LIST
PARTY ORGANIZATION

PROJECT Hammonasset Reservoir Dam

DATE 8-1-78

TIME _____

WEATHER Sunny

W.S. ELEV. 262.3 U.S. 221.7 DN.S.

PARTY:

- | | |
|---------------------------|-----------|
| 1. <u>Richard Lyon</u> | 6. _____ |
| 2. <u>Miron Petrovsky</u> | 7. _____ |
| 3. <u>J. Schearer</u> | 8. _____ |
| 4. _____ | 9. _____ |
| 5. _____ | 10. _____ |

PROJECT FEATURE

INSPECTED BY

REMARKS

- | | | |
|-----------|-------|-------|
| 1. _____ | _____ | _____ |
| 2. _____ | _____ | _____ |
| 3. _____ | _____ | _____ |
| 4. _____ | _____ | _____ |
| 5. _____ | _____ | _____ |
| 6. _____ | _____ | _____ |
| 7. _____ | _____ | _____ |
| 8. _____ | _____ | _____ |
| 9. _____ | _____ | _____ |
| 10. _____ | _____ | _____ |

Temperature of Air 65° F

Temperature of Water 73° F (upstream)

Temperature of Water 66° F (downstream)

PERIODIC INSPECTION CHECK LIST

PROJECT Hammonasset Reservoir Dam DATE 8-1-78

PROJECT FEATURE _____ NAME R. Lyon

DISCIPLINE _____ NAME G. Giroux

AREA EVALUATED	CONDITION
<u>DIKE EMBANKMENT</u>	
Crest Elevation	Good
Current Pool Elevation	Good
Maximum Impoundment to Date	Good
Surface Cracks	None observed
Pavement Condition	N/A
Movement or Settlement of Crest	None
Lateral Movement	None
Vertical Alignment	Good
Horizontal Alignment	Good
Condition at Abutment and at Concrete Structures	Good
Indications of Movement of Structural Items on Slopes	None
Trespassing on Slopes	Not permitted
Sloughing or Erosion of Slopes or Abutments	None
Rock Slope Protection - Riprap Failures	N/A
Unusual Movement or Cracking at or near Toes	None
Unusual Embankment or Downstream Seepage	N/A
Piping or Boils	N/A
Foundation Drainage Features	Concrete gravity wall on rock
Toe Drains	N/A

PERIODIC INSPECTION CHECK LIST

PROJECT Hammonasset Reservoir Dam

DATE 8-1-78

PROJECT FEATURE _____

NAME R. Lyon

DISCIPLINE _____

NAME M. Petrovsky

AREA EVALUATED	CONDITION
<u>OUTLET WORKS - CONTROL TOWER</u>	
a. Concrete and Structural	
General Condition	Good
Condition of Joints	Good
Spalling	None observed
Visible Reinforcing	None observed
Rusting or Staining of Concrete	None observed
Any Seepage or Efflorescence	None observed
Joint Alignment	None observed
Unusual Seepage or Leaks in Gate Chamber	None observed
Cracks	None observed
Rusting or Corrosion of Steel	None observed
b. Mechanical and Electrical	
Air Vents	N/A
Float Wells	N/A
Crane Hoist	N/A
Elevator	N/A
Hydraulic System	N/A
Service Gates	Gate valve underwater
Emergency Gates	Gate valve underwater
Lightning Protection System	N/A
Emergency Power System	N/A
Wiring and Lighting System in Chamber	N/A

PERIODIC INSPECTION CHECK LIST

PROJECT Hammonasset Reservoir Dam

DATE 8-1-78

PROJECT FEATURE _____

NAME R. Lyon

DISCIPLINE _____

NAME J. Schearer

AREA EVALUATED	CONDITION
<p><u>OUTLET WORKS - TRANSITION AND CONDUIT</u></p> <p>General Condition of Concrete</p> <p>Rust or Staining on Concrete</p> <p>Spalling</p> <p>Erosion or Cavitation</p> <p>Cracking</p> <p>Alignment of Monoliths</p> <p>Alignment of Joints</p> <p>Numbering of Monoliths</p>	<p>Encased in body of dam</p>

PERIODIC INSPECTION CHECK LIST

PROJECT Hammonasset Reservoir Dam

DATE 8-1-78

PROJECT FEATURE _____

NAME G. Giroux

DISCIPLINE _____

NAME M. Petrovsky

AREA EVALUATED	CONDITION
<u>OUTLET WORKS - OUTLET STRUCTURE AND OUTLET CHANNEL</u>	
General Condition of Concrete	Good
Rust or Staining	None
Spalling	None
Erosion or Cavitation	None
Visible Reinforcing	None
Any Seepage or Efflorescence	None
Condition at Joints	Good
Drain holes	None
Channel	Discharge into spillway channel
Loose Rock or Trees Overhanging Channel	N/A
Condition of Discharge Channel	N/A

PERIODIC INSPECTION CHECK LIST

PROJECT Hammonasset Reservoir Dam DATE 8-1-78

PROJECT FEATURE _____ NAME R. Lyon

DISCIPLINE _____ NAME G. Giroux

AREA EVALUATED	CONDITION
<u>OUTLET WORKS - SPILLWAY WEIR, APPROACH AND DISCHARGE CHANNELS</u>	
a. Approach Channel General Condition Loose Rock Overhanging Channel Trees Overhanging Channel Floor of Approach Channel	Underwater
b. Weir and Training Walls	Good
General Condition of Concrete	
Rust or Staining	Some due to iron content in water
Spalling	None
Any Visible Reinforcing	None
Any Seepage or Efflorescence	Some at construction and expansion joint as well as rock interface
Drain Holes	None
c. Discharge Channel	
General Condition	Fair to good
Loose Rock Overhanging Channel	Natural boulder in channel
Trees Overhanging Channel	Several
Floor of Channel	Rocky, with several large boulders
Other Obstructions	None

PERIODIC INSPECTION CHECK LIST

PROJECT Hammonasset Reservoir Dam

DATE 8-1-78

PROJECT FEATURE _____

NAME J. Schearer

DISCIPLINE _____

NAME M. Petrovsky

AREA EVALUATED	CONDITION
<u>OUTLET WORKS - SERVICE BRIDGE</u>	
a. Super Structure to intake	
Bearings	Good
Anchor Bolts	None
Bridge Seat	Good
Longitudinal Members	Some spalling
Under Side of Deck	Some spalling
Secondary Bracing	Good
Deck	Some spalling
Drainage System	None
Railings	Some corrosion
Expansion Joints	Some damage
Paint	None
b. Abutment & Piers	
General Condition of Concrete	Good
Alignment of Abutment	Good
Approach to Bridge	Good
Condition of Seat & Backwall	Some damage in bridge seat area

APPENDIX B

LIST OF REFERENCES

B-1

GENERAL PLAN

Plate 1

SECTION AND DETAILS

Plate 2

HAMMONASSET RESEI

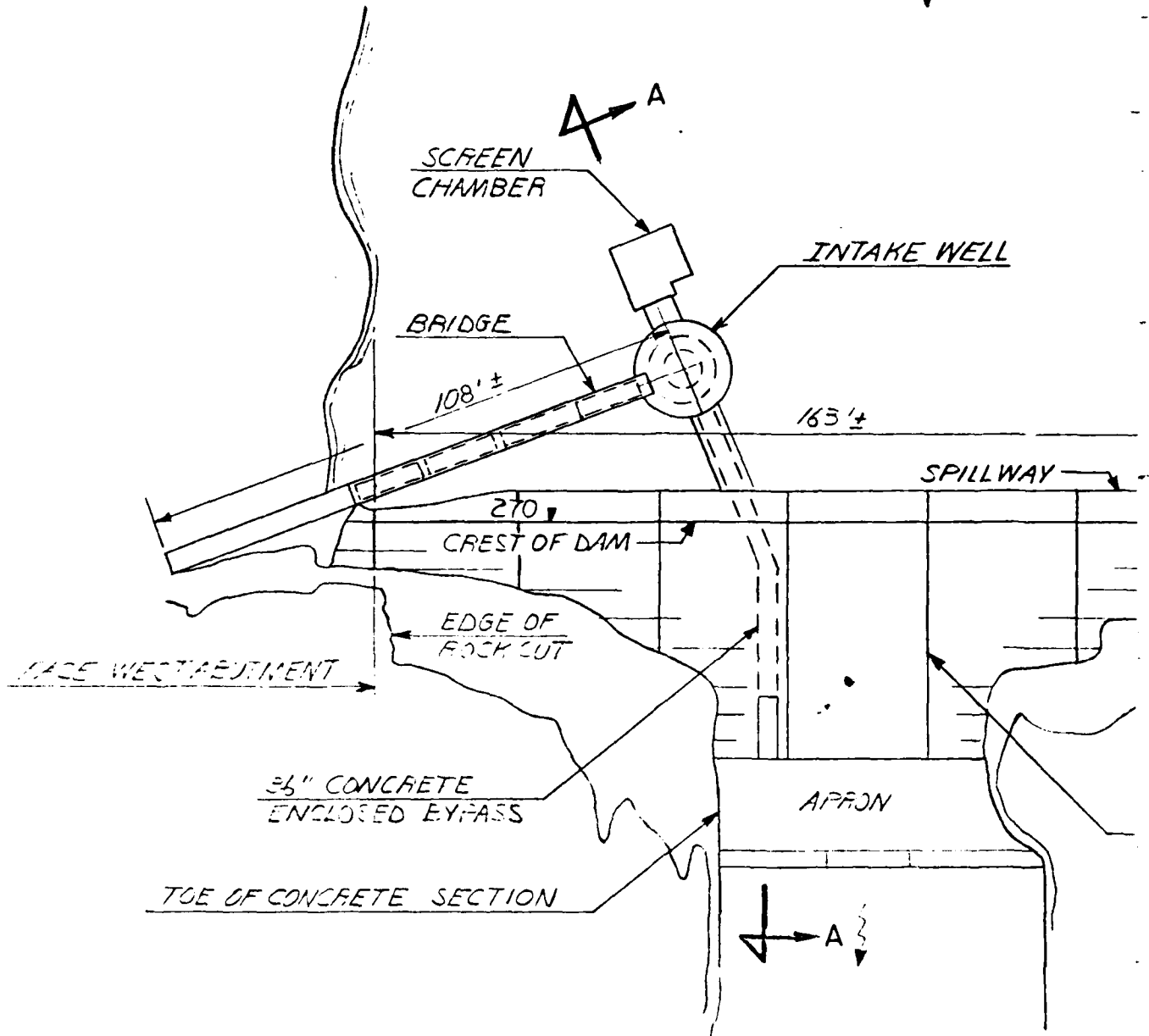

PLAN
NOT TO SCALE

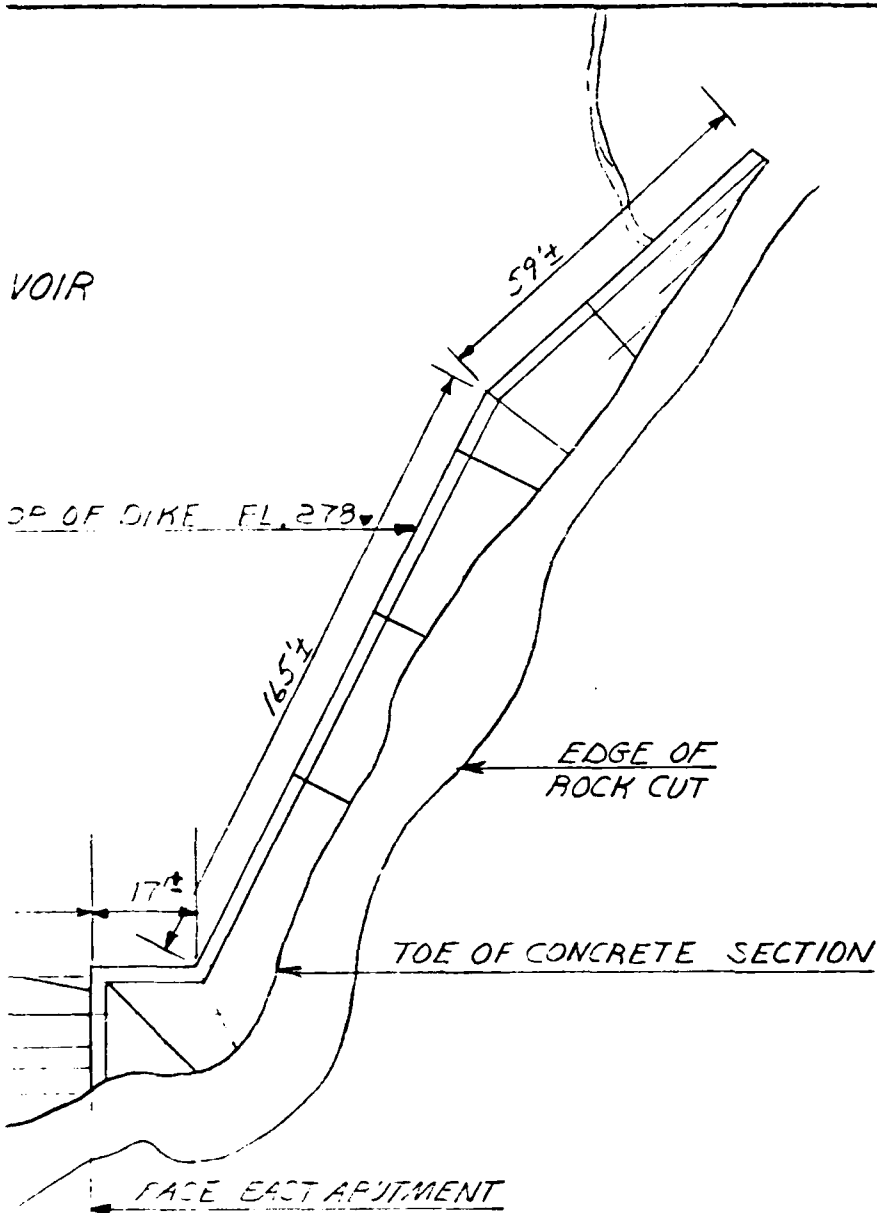

NOTE :

INFORMATION TAKEN FROM DRAWINGS
SUPPLIED BY NEW HAVEN WATER CO.

CONSTRUCTION JOINTS (TYP)

PLATE-1

STORCH ENGINEERS WETHERSFIELD, CONNECTICUT		U.S. ARMY ENGINEER DIV. NEW ENGLAND CORPS OF ENGINEERS WALTHAM, MASS.	
NATIONAL PROGRAM OF INSPECTION OF NON-FED. DAMS HAMMONASSET RESERVOIR DAM HAMMONASSET RIVER			
		CONNECTICUT	
		SCALE: AS SHOWN	
		DATE : AUGUST 1978	

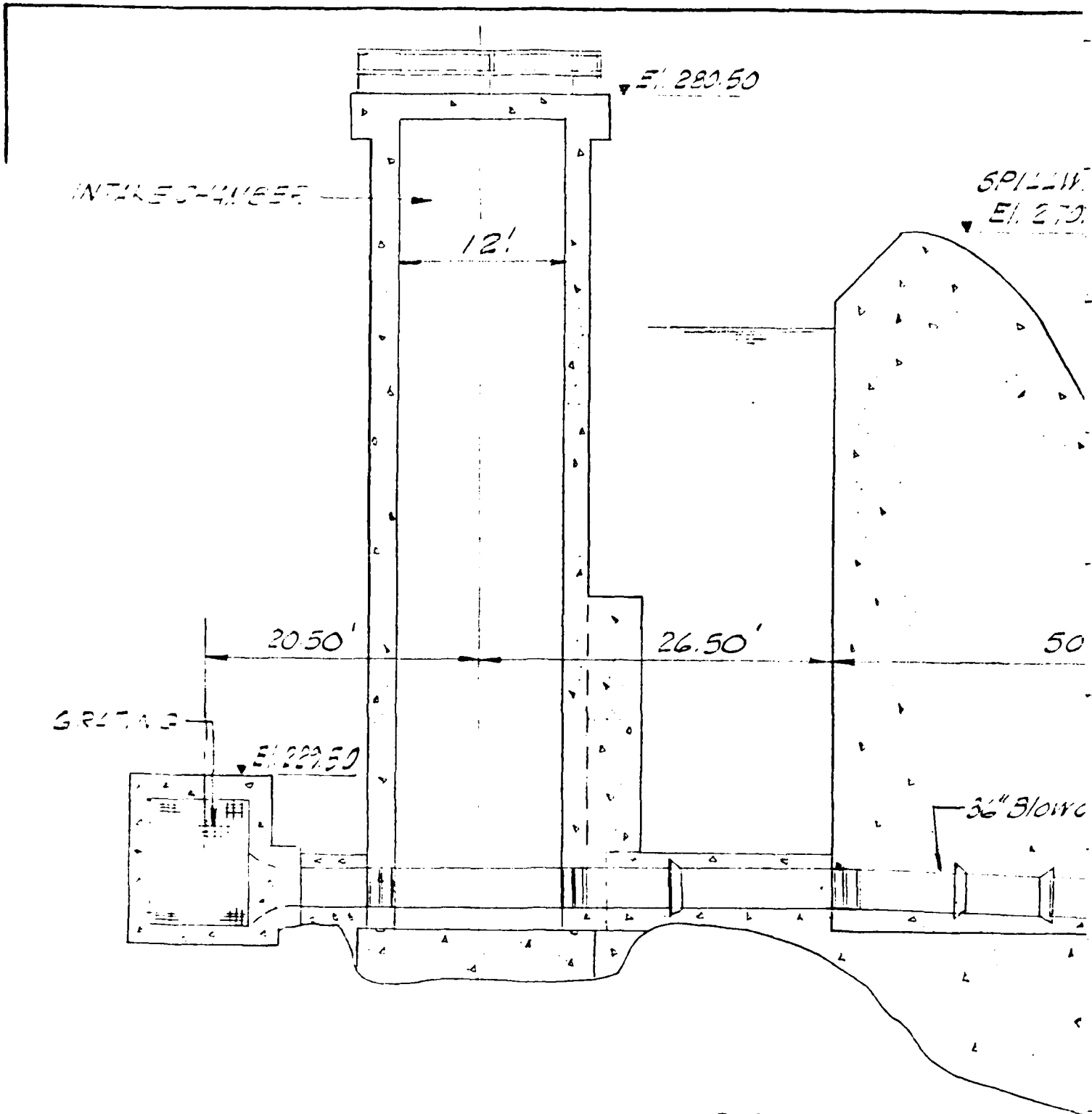

NOTE:
 INFORMATION TAKEN FROM DRAWINGS
 SUPPLIED BY NEW HAVEN WATER COMPANY

SECTION A-A
 SCALE: 1" = 10'

Y CREST
22

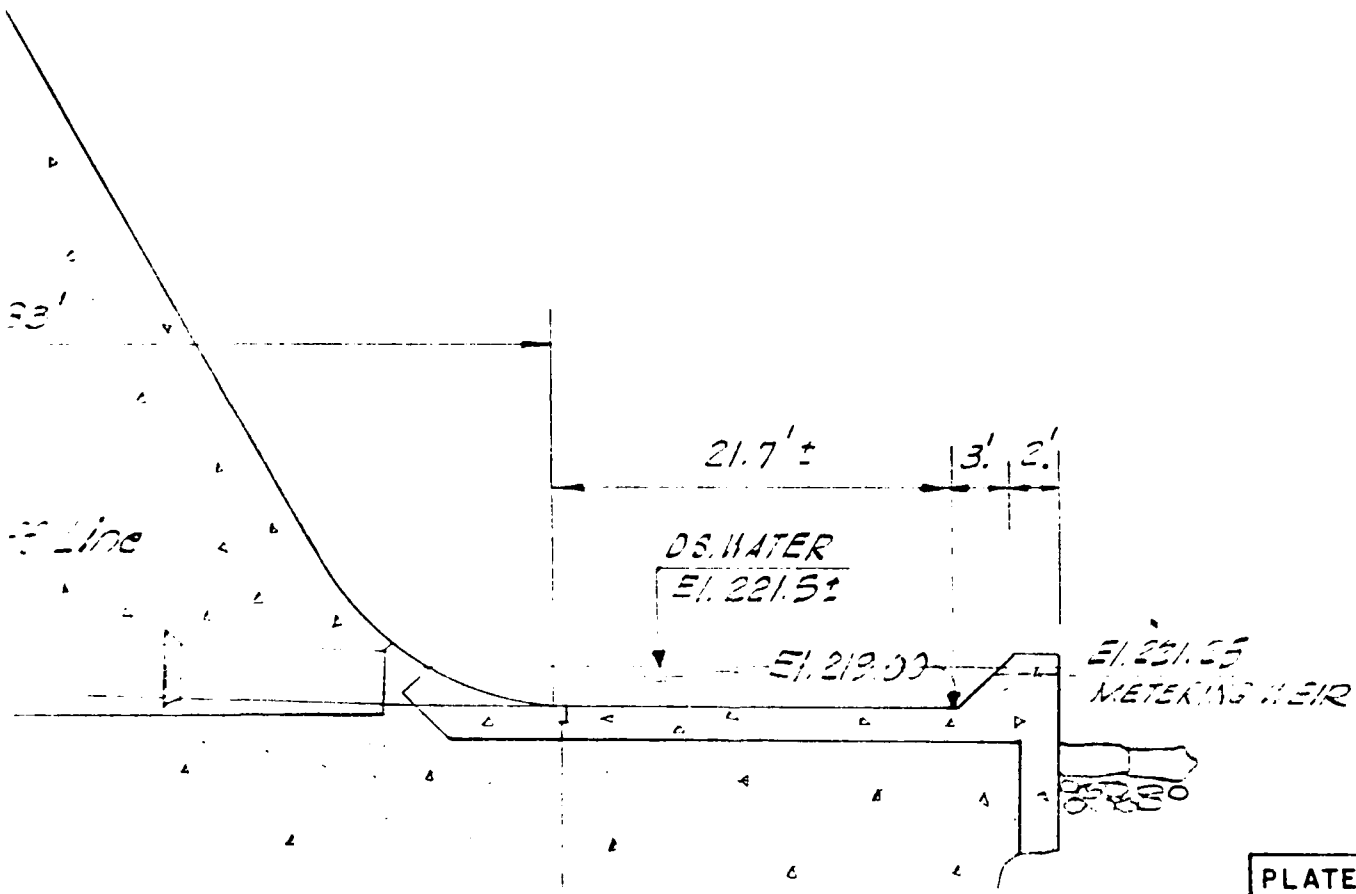

PLATE-2

STORCH ENGINEERS
WETHERSFIELD, CONNECTICUT

U.S. ARMY ENGINEER DIV. NEW ENGLAND
CORPS OF ENGINEERS
WALTHAM, MASS.

NATIONAL PROGRAM OF INSPECTION OF NON-FED. DAMS

HAMMONASSET RESERVOIR DAM

HAMMONASSET RIVER

CONNECTICUT

SCALE: AS SHOWN

DATE : AUGUST 1978

LIST OF REFERENCES

1. Drawings of Hammonasset Dam: (1) Location Plan; (2) Plan of Dam and Details; (3) Dam and Intake Chamber; (4) Dam profile and Sections; (5) Plan of Dike and Details; (7) Typical Sections; (8) Situation Plan and Access Road Location; New Haven Water Company; New Haven, Connecticut; March, 1957.
2. Recommended Guidelines for Safety Inspection of Dams; Department of the Army; Office of the Chief of Engineers; Washington, D.C.; November, 1976.
3. "Guide Curves for the Probable Maximum Flood (PMF) for Regions of New England Based on Corps of Engineers' studies; March, 1978.
4. "Preliminary Guidance for Estimating Maximum Probable Discharges in Phase I Dam Safety Investigations"; New England Division; Corps of Engineers; March, 1978.
5. Rule of Thumb. Guidance for Estimating Downstream Dam Failure Hydrographs; Corps of Engineers; April, 1978.
6. Capacity of Hammonasset Reservoir above minimum effective level; New Haven Water Company; New Haven, Connecticut; June 17, 1957.

APPENDIX C

PHOTO LOCATION PLAN

Plate 3

PHOTOGRAPHS

II-1 to II-4

HAMMONASSET RESE.

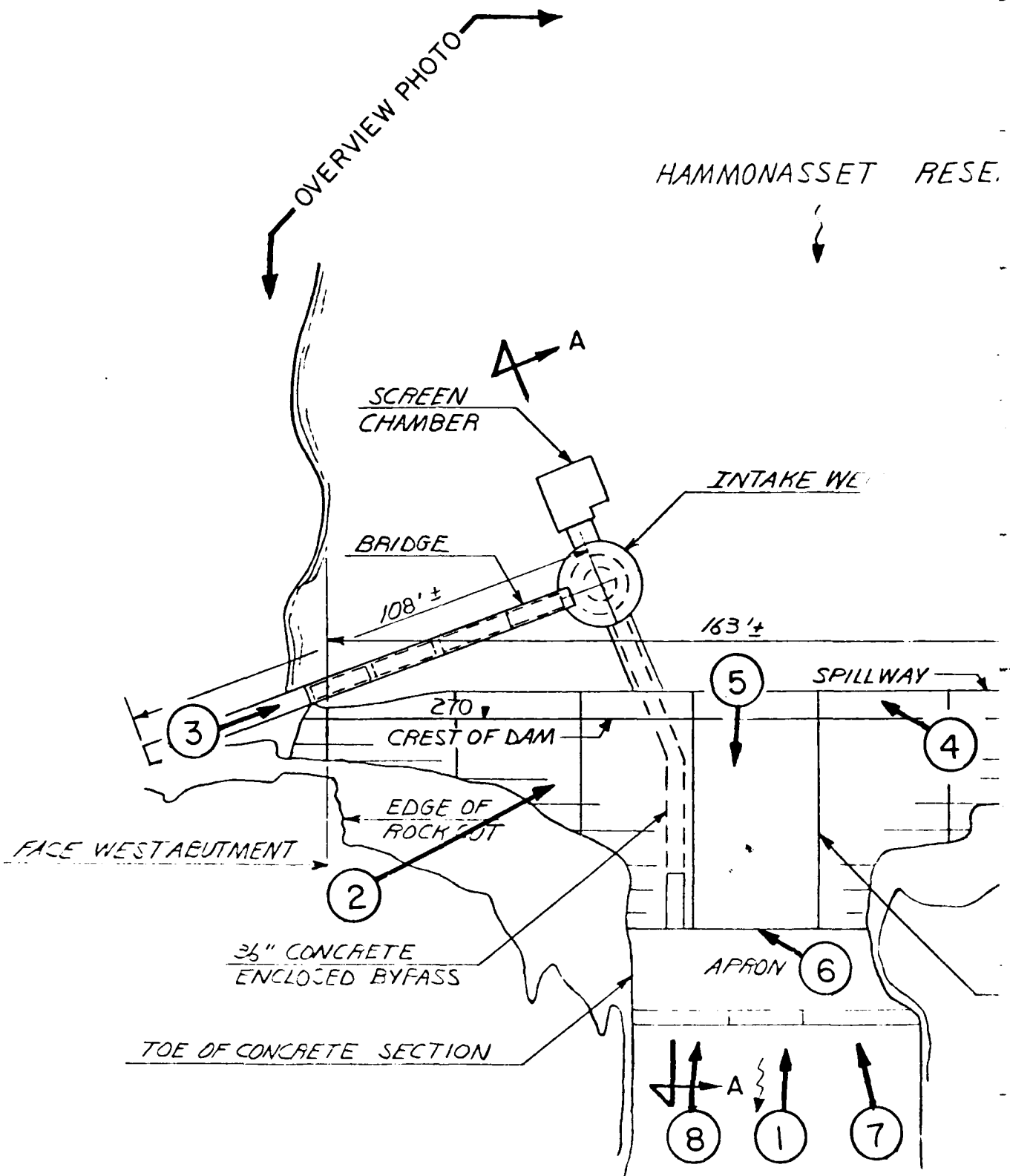

PLAN

NOT TO SCALE

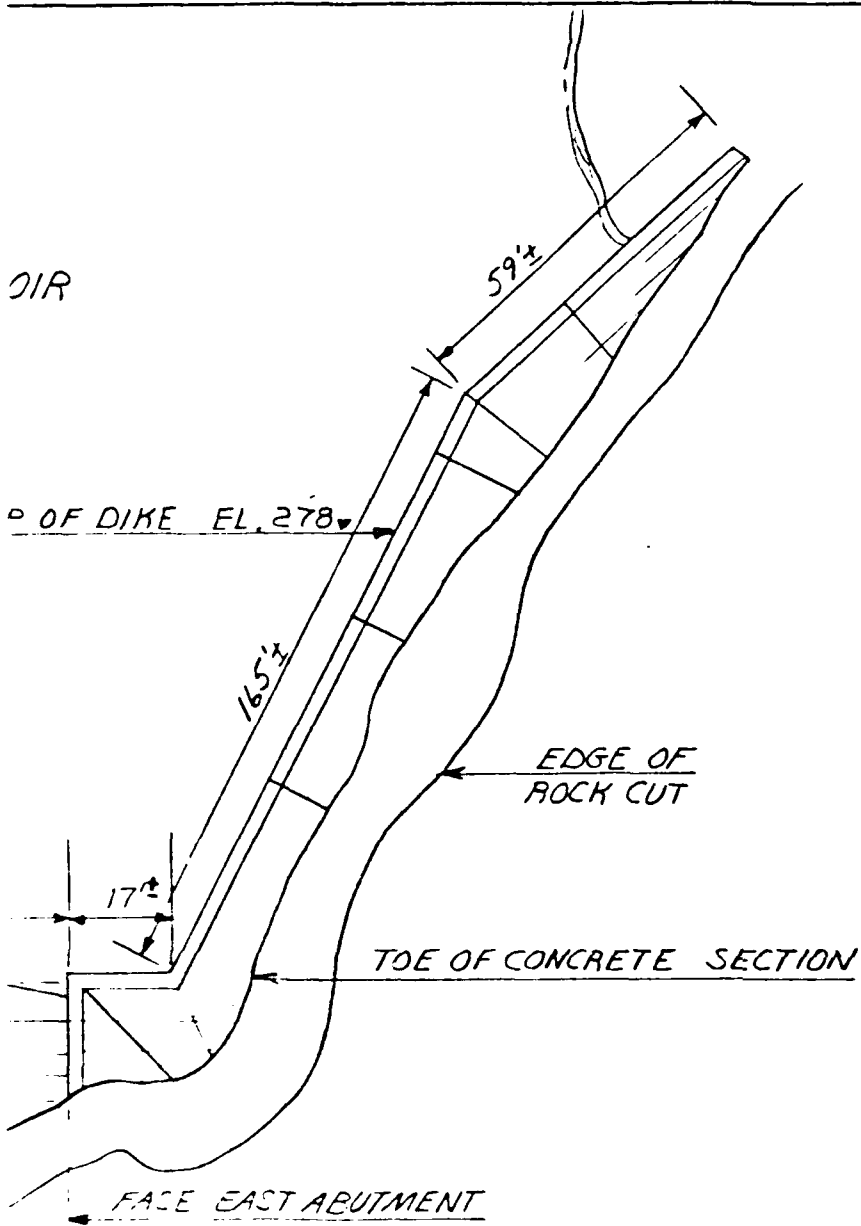

OIR

P OF DIKE EL. 278

16.5'±

59'±

17'±

EDGE OF ROCK CUT

TOE OF CONCRETE SECTION

FACE EAST ABUTMENT

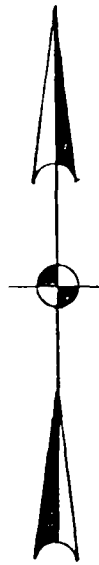

NOTE: INFORMATION TAKEN FROM DRAWINGS SUPPLIED BY NEW HAVEN WATER CO.

CONSTRUCTION JOINTS (TYP)

PLATE-3

STORCH ENGINEERS WETHERSFIELD, CONNECTICUT		U.S. ARMY ENGINEER DIV. NEW ENGLAND CORPS OF ENGINEERS WALTHAM, MASS.	
NATIONAL PROGRAM OF INSPECTION OF NON-FED. DAMS			
HAMMONASSET RESERVOIR DAM			
HAMMONASSET RIVER		CONNECTICUT	
		SCALE: AS SHOWN	
		DATE: AUGUST 1978	



PHOTO 1
DOWNSTREAM FACE OF DAM



PHOTO 2
CREST OF DAM

II-1

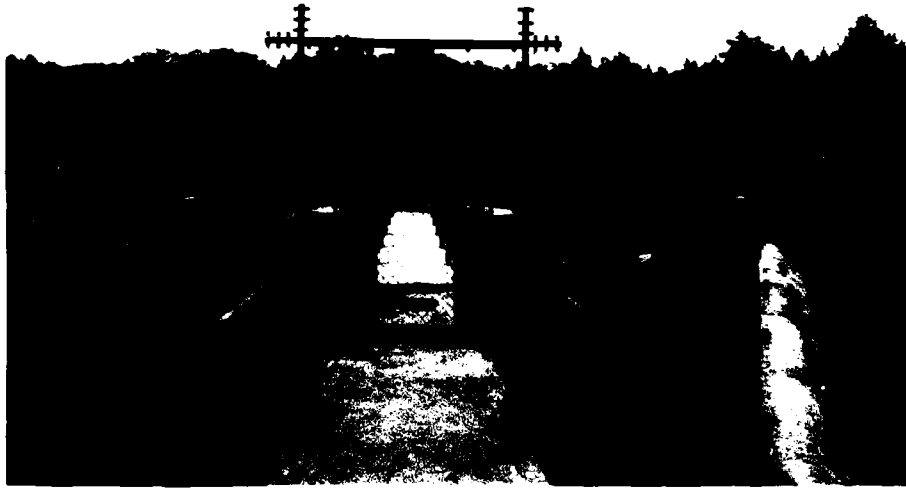

PHOTO 3
WALKWAY OF BRIDGE TO INTAKE WELL



PHOTO 4
CREST OF DAM LOOKING AT INTAKE WELL



PHOTO 5
LOOKING DOWNSTREAM FROM CREST OF DAM



PHOTO 6
SEEPAGE AT JUNCTION OF ROCK AND DAM



PHOTO 7
SEEPAGE AT FACE OF DAM



PHOTO 8
SEEPAGE AT FACE OF DAM

APPENDIX D

HYDRAULIC COMPUTATIONS
REGIONAL VICINITY MAP

D-1 to D-7
Plate 4

STORCH ENGINEERS
 Engineers - Landscape Architects
 Planners - Environmental Consultants

HAMMONASSET RESERVOIR DAM
 STAGE DISCHARGE

SEE PLATES § FOR PLAN & ELEVATION

$$Q = C L H^{3/2}$$

ELEV	SPILLWAY				DAM				Q _T
	H	C	L	Q	H	C	L	Q	
270	0	0	163	0					
271	1	3.28		535					535
272	2	3.35		1,545					1,545
273	3	3.47		2,940					2,940
274	4	3.55		4,525					4,525
275	5	3.67		6,690					6,690
276	6	3.74		8,960					8,960
277	7	3.82		11,530					11,530
278	8	3.9		14,385	0	0	284	0	14,385
279	9	3.98		17,515	1	2.66		755	18,270
280	10	4.10		21,135	2	2.85		2290	23,425

HAMMONASSET RESERVOIR DAM
STAGE DISCHARGE

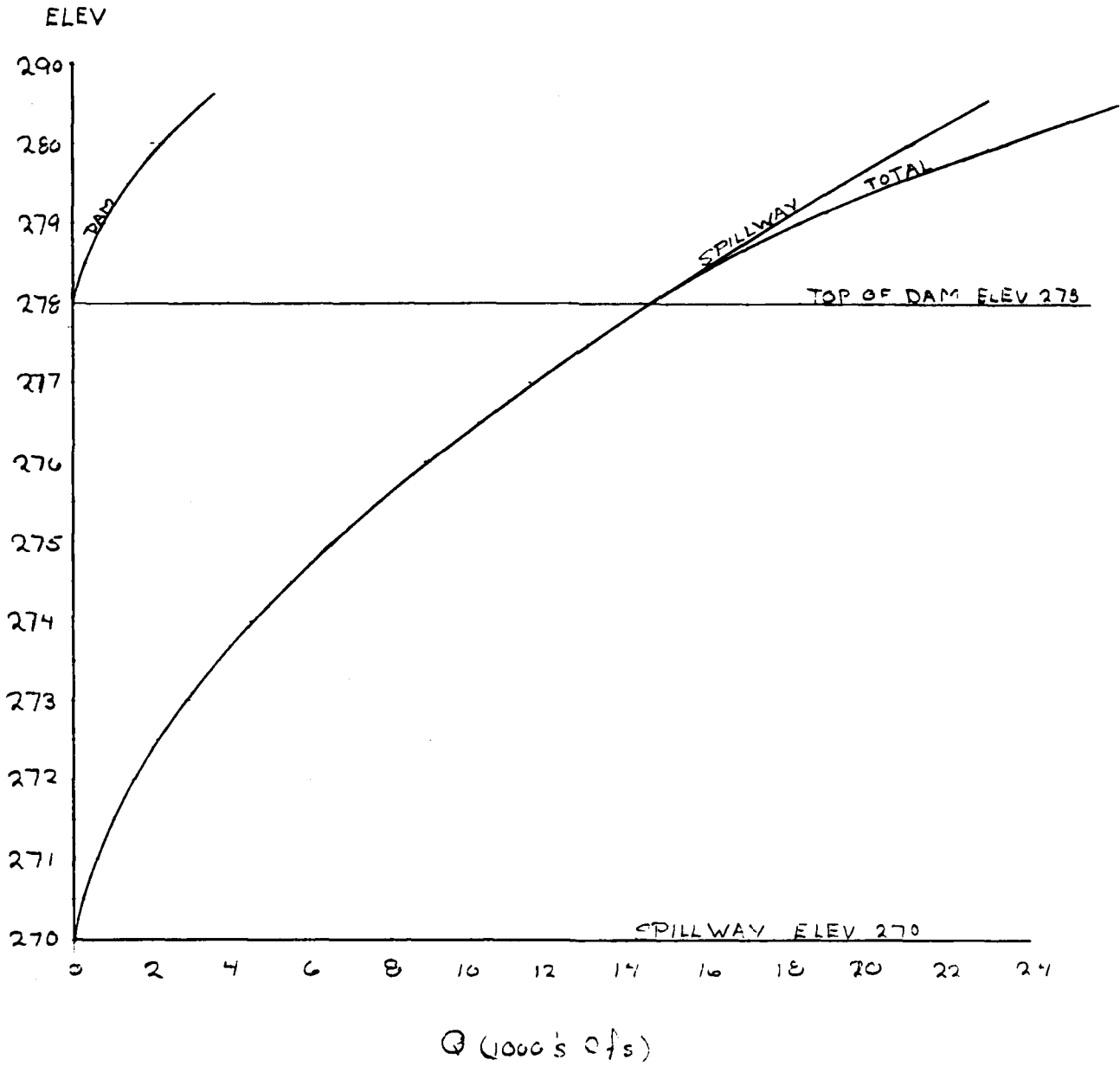

STORCH ENGINEERS
 Engineers - Landscape Architects
 Planners - Environmental Consultants

HAMMONASSET RESERVOIR DAM
 AREA-CAPACITY CURVE

ELEV	DEPTH	AREA	AVG. AREA	VOL	Σ VOL. (ACFT)
270	-	310	-	-	5450
	8		360	2880	
278		410			8330
	12		865	10,380	
290		1320			18,710

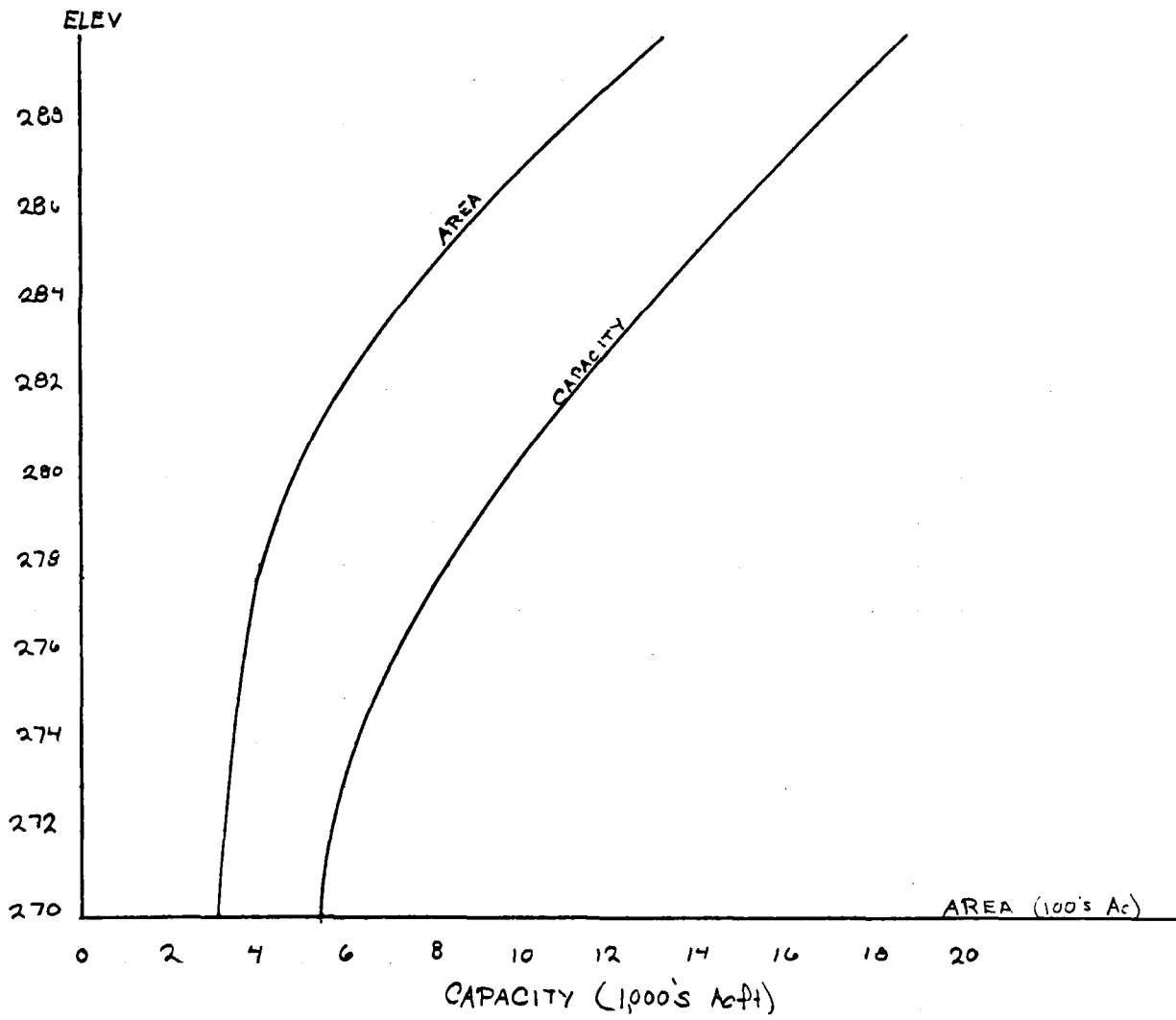

HAMMONASSET RESERVOIR DAM
DETERMINATION OF SDF & PMF

DRAINAGE AREA - 19.5 SM

INFLOW (Ref. 4) - 1450 cfs/SM

$$PMF = 1450(19.5) = 28275 \text{ cfs}$$

Determine the effect of surcharge storage on Maximum Probable Discharge.

① $Q_{P1} = 28275 \text{ cfs}$

② a. $H_1 = 287 \text{ (ELEV)}$

b. $STOR_1 = 9.95 \text{ ''}$

c. $Q_{P2} = Q_{P1} (1 - \frac{STOR_1}{19}) = 28275 (1 - \frac{9.95}{19}) = 13,460 \text{ cfs}$

③ a. $H_2 = 277.7 \text{ (ELEV)}$

$STOR_2 = 2.55 \text{ ''}$

b. $STOR_A = 6.25 \text{ ''}$

$Q_{P3} = 28275 (1 - \frac{6.25}{19}) = 18,975 \text{ cfs}$

$H_3 = 279.15$

$$PMF = 18,975 \text{ cfs}$$

Capacity of Spillway when the pond elevation is @ the top of the dam.

$$Q = 14,385 \text{ cfs} \quad \text{or} \quad 75.8\% \text{ of the PMF}$$

STORCH ENGINEERS
 Engineers - Landscape Architects
 Planners - Environmental Consultants

HAMMONASSET RESERVOIR DAM
 SECTION NO 1

$n = .035$ $S = .9\%$

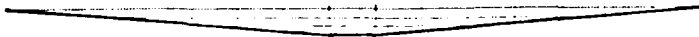

D	W ^D	A	R	R ^{2/3}	S ^{1/2}	V	Q
5	140	400	2.95	2.0	.095	8.0	3,225
10	290	1300	4.48	2.72	.095	10.9	14,260
20	490	5200	10.6	4.83	.095	19.5	101,300
30	740	10800	17.6	5.98	.095	24.1	260,500

SECTION NO. 2

$n = .035$ $S = .05\%$

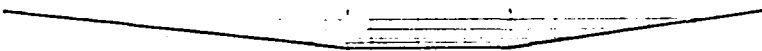

D	W ^D	A	R	R ^{2/3}	S ^{1/2}	V	Q
5	490	1900	3.87	2.47	.022	2.31	4385
10	650	4800	7.38	3.79	.022	3.54	16,990
20	960	13000	13.7	5.73	.022	5.35	69,580
30	1350	22500	16.7	6.53	.022	6.1	137,240
40	1650	33000	23.0	8.1	.022	7.56	287,502

STORCH ENGINEERS
Engineers - Landscape Architects
Planners - Environmental Consultants

HAMMONASSET RESERVOIR DAM

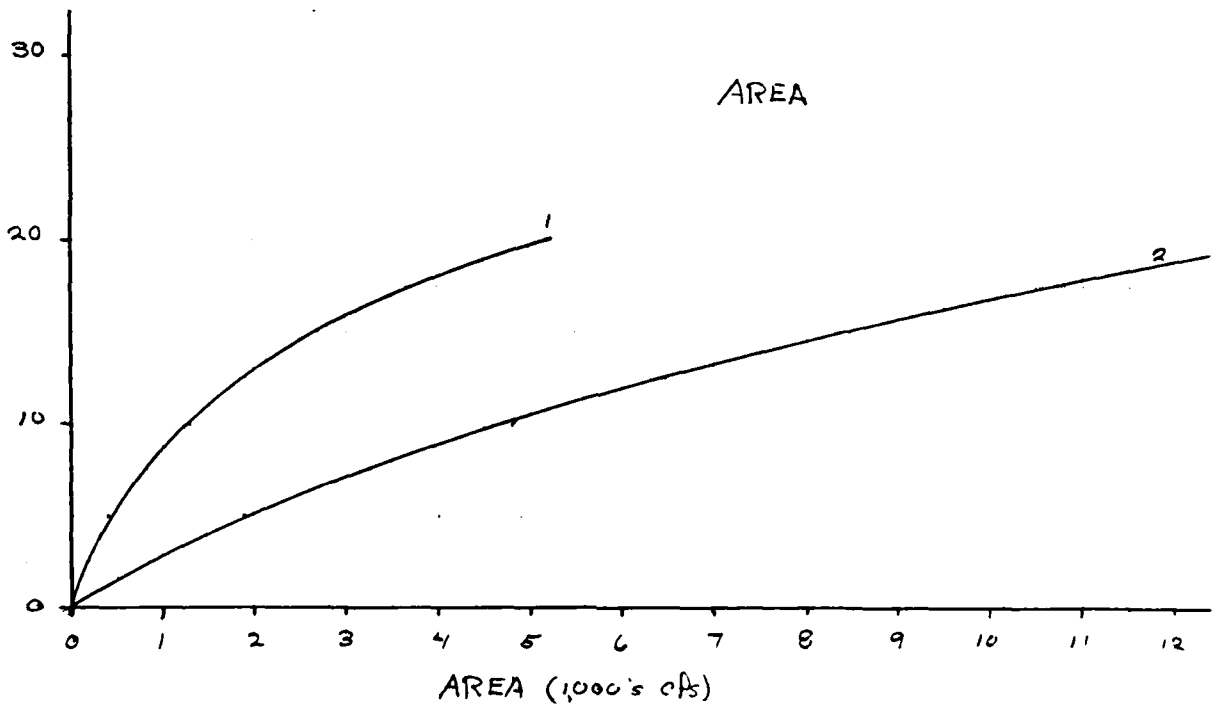
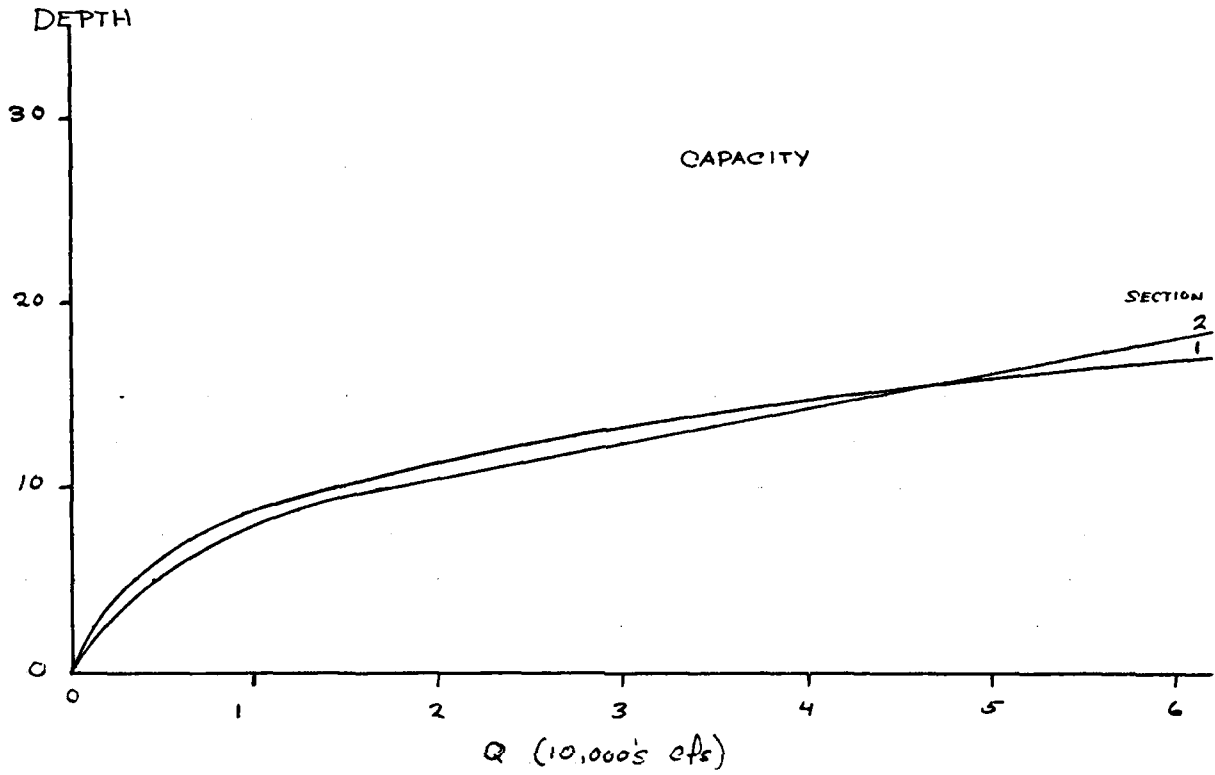

HAMMONASSET RESERVOIR DAM

"RULE OF THUMB" GUIDANCE FOR ESTIMATING DOWNSTREAM DAM
 FAILURE HYDROGRAPHS

SECTION 1 @ Dam

① $S = 5450 \text{ A cft}$

② $Q_{P1} = \frac{8}{27} W \sqrt{g} Y^{3/2} = \frac{8}{27} (65) (\sqrt{32.2} \cdot 50)^{3/2} = 38640 \text{ cfs}$

SECTION 2 @ Chestnut Hill Rd.

③ see stage discharge Curve No 1

④ a. $H_1 = 14.5'$ $A_1 = 2600 \text{ ft}^2$ $L_1 = 11,600'$ $V_1 = 692 \text{ A cft}$

b. $Q_{P2} = 38600 (1 - 692/5450) = 33700 \text{ cfs}$

c. $H_2 = 13.5'$ $A_2 = 2250$

$A_{avg} = 2425$ $V_{avg} = 645 \text{ A cft}$

d. $Q_{P2} = 38600 (1 - 645/5450) = 34,030 \text{ cfs}$

$H_2 = 13.7'$ $A_2 = 2300 \text{ ft}^2$

SECTION 3 @ Madison, Clinton & Killingworth Town Lines Section 1

④ a. $H_2 = 13.7$ $A_2 = 2300 \text{ ft}^2$ $L_2 = 14,800'$ $V_2 = 781 \text{ A cft}$

b. $Q_{P2} = 34030 (1 - 781/5450) = 29,150 \text{ A cft}$

c. $H_3 = 13.0'$ $A_3 = 2050 \text{ ft}^2$

$A_{avg} = 2175 \text{ ft}^2$ $V_{avg} = 740 \text{ A cft}$

d. $Q_{P3} = 34030 (1 - 740/5450) = 29,410 \text{ cfs}$

$H_3 = 13.1$ $A_2 = 2100 \text{ ft}^2$

SECTION 4 @ Boston Post Rd Section 2

④ a. $H_3 = 13.1$ $A_3 = 2100 \text{ ft}^2$ $L_3 = 18,000'$ $V_3 = 870 \text{ A cft}$

b. $Q_{P4} = 29410 (1 - 870/5450) = 24,700 \text{ cfs}$

c. $H_4 = 11'$ $A_4 = 5500$

$A_{avg} = 3800 \text{ ft}^2$ $V_{avg} = 1570 \text{ A cft}$

d. $Q_{P4} = 29410 (1 - 1570/5450) = 20,940$

$H_4 = 10.5'$

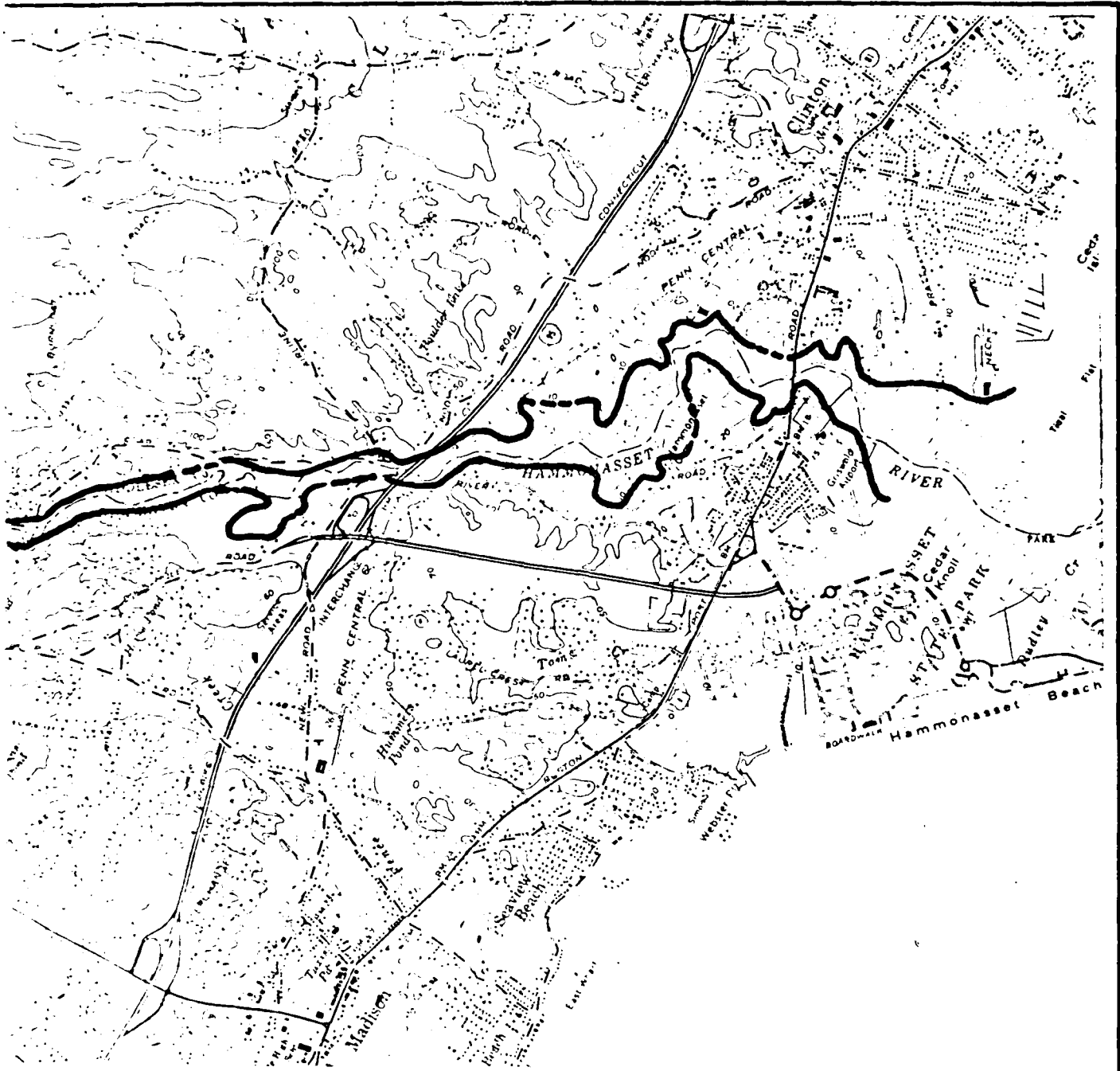

AL VICINITY MAP

PLATE-4

STORCH ENGINEERS
WETHERSFIELD, CONNECTICUT

U.S. ARMY ENGINEER DIV. NEW ENGLAND
CORPS OF ENGINEERS
WALTHAM, MASS.

NATIONAL PROGRAM OF INSPECTION OF NON-FED. DAMS

HAMMONASSET RESERVOIR DAM

HAMMONASSET RIVER

CONNECTICUT

SCALE: AS SHOWN

DATE: AUGUST 1978

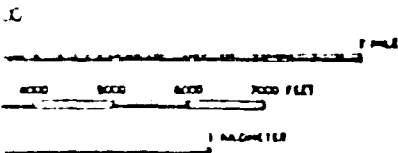

10 FEET
LEVEL

APPENDIX E

INFORMATION AS CONTAINED IN THE
NATIONAL INVENTORY OF DAMS

END

FILMED

10-84

DTIC