

AD-A144 795

AN APPROACH TO ESTIMATING THE MISSION EFFECTIVENESS FOR  
FEASIBLE DESIGN ALTERNATIVES(U) MASSACHUSETTS INST OF  
TECH CAMBRIDGE DEPT OF OCEAN ENGINEERIN. W P TAYLOR  
MAY 84 N66314-70-A-0073

1/1

UNCLASSIFIED

F/G 13/10

NL

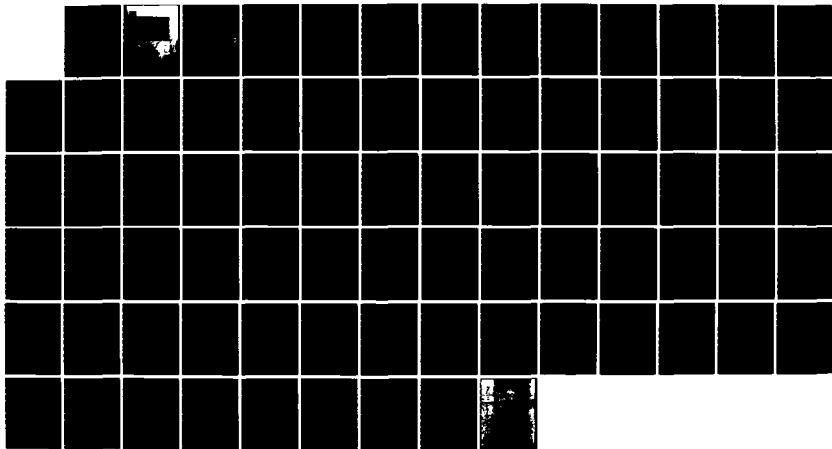

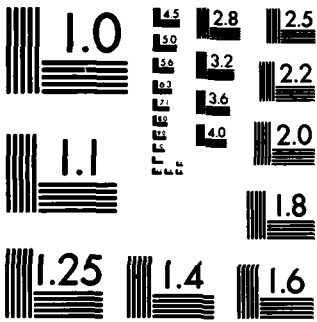

MICROCOPY RESOLUTION TEST CHART  
NATIONAL BUREAU OF STANDARDS-1963-A

AD-A144 795

DEPARTMENT OF OCEAN ENGINEERING  
MASSACHUSETTS INSTITUTE OF TECHNOLOGY  
CAMBRIDGE, MASSACHUSETTS 02139

---

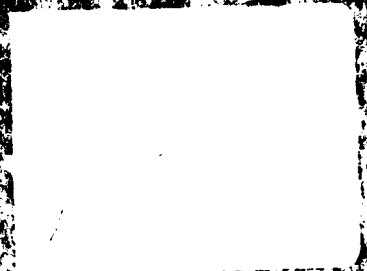

①

AN APPROACH TO ESTIMATING  
THE MISSION EFFECTIVENESS  
FOR FEASIBLE DESIGN ALTERNATIVES

by

WESLEY PATTERSON TAYLOR

B. S. Mech. Eng., Massachusetts Institute of Technology  
(1976)

SUBMITTED TO THE DEPARTMENT OF  
OCEAN ENGINEERING  
IN PARTIAL FULFILLMENT OF THE REQUIREMENTS  
FOR THE DEGREES OF

OCEAN ENGINEER

and

MASTER OF SCIENCE IN MECHANICAL ENGINEERING

at the

MASSACHUSETTS INSTITUTE OF TECHNOLOGY  
May, 1984

NG6314-70-A-0073

DTIC  
SELECTED  
AUG 24 1984  
S D E

© Wesley Patterson Taylor, 1984

The author hereby grants to M.I.T. and the U.S. NAVY  
permission to distribute copies of this thesis document in  
whole or in part.

Signature of Author..... *Wesley P. Taylor* .....  
Department of Ocean Engineering  
May, 1984

Certified by..... *David V. Burke* .....  
Professor David V. Burke  
Thesis Supervisor

Accepted by..... *A. Douglas Charmichael* .....  
Professor A. Douglas Charmichael, Chairman  
Departmental Graduate Committee  
Department of Ocean Engineering

Accepted by..... *Warren M. Rohsenow* .....  
Professor Warren M. Rohsenow, Chairman  
Departmental Committee on Graduate Studies  
Department of Mechanical Engineering

This document has been approved  
for public release and sale; its  
distribution is unlimited.

AN APPROACH TO ESTIMATING THE MISSION  
EFFECTIVENESS FOR FEASIBLE DESIGN ALTERNATIVES

By

WESLEY PATTERSON TAYLOR

Submitted to the Department of Ocean Engineering  
on May 21, 1984 in partial fulfillment of the  
requirements for the degrees of Ocean Engineer and  
Master of Science in Mechanical Engineering

ABSTRACT

*Key to this approach is determining*

An approach was developed by the author to estimate the effect of seakeeping on the mission effectiveness of a feasible design. The key to this approach is the application of a model of the mission as a system wherein the functions which perform the mission have the same relationship to each other as the components do in a physical system. The degradation in the performance of the mission is calculated in the same manner as the reliability of a system made up of separate components. This model is incorporated into the feasibility study stage of the ship design process, and the modified procedure is described.

The approach is illustrated by applying it to a single example of a monohull. The functions necessary to perform a given mission and the relationships between separate functions were determined. Physical subsystems which perform those functions were selected and substituted into the functional relationship. A regression-based computer ship synthesis program for destroyer-type ships was used to obtain the hull form characteristics necessary to create a prototype hull form. A prototype hull was developed using a hull form generation program which uses parametric cubic splines to build a definition of the ship's hull. Five locations on the hull were selected and each subsystem assigned to be at or near one of those locations. The vertical motions of those locations were calculated for the case of long crested head seas using Lewis-form approximation to the ship's hull. The motions were used to determine the relative effectiveness of each subsystem from its performance degradation function. The relative mission effectiveness was computed using the algorithm used to compute the reliability for a subsystem composed of different components.

Thesis Supervisor: Dr. David V. Burke

Title: Professor of Ocean Engineering

**ACKNOWLEDGEMENTS**

The approach to estimating mission effectiveness presented here is the result of a suggestion from Commander E.C. Munger, USN

Ed Comstock, head of the Hull Form Design and Performance Division at NAVSEA was an invaluable source of ideas, suggestions, knowledge and resources.

Dave Walden and Susan Bales of DTNSRDC both were very helpful in providing insight and resources for this thesis.

Steve Petrie who understands probability and random processes helped considerably in improving my own understanding.

Captain Burke and Commander Tinkel kept me on track.

I am especially grateful to Jan for her patience and support and to Patti for her smiles.

Accession For	
NTIS GRA&I	<input checked="" type="checkbox"/>
DTIC TAB	<input type="checkbox"/>
Unannounced	<input type="checkbox"/>
Justification	<i>form 50 per</i>
By	
Distribution/	
Availability Codes	
Dist	Avail and/or Special
<i>A-1</i>	



## TABLE OF CONTENTS

ABSTRACT	2
ACKNOWLEDGEMENTS	3
TABLE OF CONTENTS	4
LIST OF FIGURES	6
LIST OF TABLES	7
1 BACKGROUND	8
DEFINITION OF SEAKEEPING	8
CURRENT PRACTICE FOR DESIGN FOR SEAKEEPING	9
AN ALTERNATIVE APPROACH	10
2 A DEFINITION OF MISSION EFFECTIVENESS	11
A PROPOSED MODEL FOR A MISSION STRUCTURE	11
HOW FUNCTIONS ARE RELATED TO EACH OTHER IN THIS MODEL	12
SUBSYSTEMS AND THEIR RELATION TO FUNCTIONS	14
CALCULATION OF RELATIVE MISSION EFFECTIVENESS	15
3 A MODIFIED FEASIBLE DESIGN PROCESS	18
MISSION REQUIREMENTS	20
DETERMINATION OF FUNCTIONS TO PERFORM THE MISSION	20
DETERMINATION OF THE MISSION STRUCTURE	21
SELECTION OF SUBSYSTEMS	21
SYNTHESIS OF SHIP DESIGN ALTERNATIVES	23
DEVELOPMENT OF A HULL SHAPE	25
ASSIGNMENT OF SUBSYSTEMS TO LOCATIONS	25
CALCULATION OF SHIP MOTIONS	27

TABLE OF CONTENTS (CONT.)

	CALCULATION OF RELATIVE MISSION EFFECTIVENESS	27
4	ILLUSTRATION OF THE PROCESS FOR A SINGLE MONOHULL DESIGN	29
	MISSION STRUCTURE	29
	SYNTHESIS OF THE DESIGN	30
	SHIP MOTIONS	31
	MISSION EFFECTIVENESS CALCULATION	32
5	CONCLUSIONS AND RECOMMENDATIONS	34
	CONCLUSIONS	34
	RECOMMENDATIONS	35
	REFERENCES	38
	BIBLIOGRAPHY	38
	APPENDIX I	41
	APPENDIX II	56
	APPENDIX III	60

## LIST OF FIGURES

FIGURE	PAGE
(2-1) A HYPOTHETICAL MISSION STRUCTURE	13
(3-1) PROPOSED FEASIBLE DESIGN PROCESS	19
(3-2) ILLUSTRATION OF SERIES-PARALLEL MISSION STRUCTURE	22
(3-3) SERIES-PARALLEL MISSION STRUCTURE INCLUDING SUBSYSTEMS	23
(A-1) TOP LEVEL FUNCTION DIAGRAM	44
(A-2) DIAGRAM OF FUNCTIONS NECESSARY TO EACH WARFARE AREA	45
(A-3) ASW MISSION EXPANDED INTO ITS COMPONENT SUBSYSTEMS	48
(A-4) AAW MISSION EXPANDED INTO ITS COMPONENT SUBSYSTEMS	49
(A-5) SUW MISSION EXPANDED INTO ITS COMPONENT SUBSYSTEMS	49
(A-6) MISSION EFFECTIVENESS, FIVE KTS. SEA STATE SIX	54
(A-7) MISSION EFFECTIVENESS, FIFTEEN KTS. SEA STATE SIX	55

LIST OF TABLES

TABLE	PAGE
(A-1) SUBSYSTEMS FOR THE DESIGN ALTERNATIVE	47
(A-2) LOCATION OF MAJOR SUBSYSTEMS	51

CHAPTER 1  
BACKGROUND

DEFINITION OF SEAKEEPING

Increasingly, the United States Navy is including seakeeping as a performance requirement in the design of new US Navy ships. The definition of seakeeping widely accepted by the US Navy design community, and which will be used here was given by Vice Admiral R. E. Adamson:

"Seakeeping as it pertains to the U.S. NAVY, is the ability of our ships to go to sea and successfully and safely execute their mission despite adverse environmental factors." [1]

The ship's response to waves causes a decrease in the ability of equipment and personnel to perform many functions. Seakeeping performance, also called mission effectiveness, is the measure of the ship's ability to carry out a mission fully and completely. More specifically, a ship with ideal seakeeping qualities is capable of performing its mission in all but the roughest seas; it is not limited to a particular

direction with respect to waves, nor to less than its rated top speed, nor is any operation it may be assigned to conduct limited by sea state alone.

#### CURRENT PRACTICE IN DESIGN FOR SEAKEEPING

The Naval Sea Systems Command (NAVSEA) is the chief design agent for new ships for the U.S. Navy. At NAVSEA, efforts are focused on three design areas when designing for good seakeeping qualities. [2] The first is the hull configuration. Within the limits of several non-seakeeping constraints which deal with power and speed, arrangements, center of gravity, stability and structural strength, the designer strives for the shape which minimizes overall ship motions and events such as slamming and deck wetness. The designer tries to optimize features such as freeboard, shear, and secondary hull form parameters [3]. The second area is the arrangement of motion sensitive equipment in order to minimize the effects of motion. The third area is the design of the equipment to minimize the effects of the ship's motion on the performance of the equipment. In the third area equipment is usually not designed with a particular ship in mind, but with the intention of installing it on many classes of ships. In the first two areas the optimization is done once a design alternative has been selected for further development.

## AN ALTERNATIVE APPROACH

The optimization of the design for good seakeeping qualities begins after the feasible design process has selected "best" alternative. There is currently no method for predicting quantitatively how the seakeeping qualities of a design alternative will affect its mission effectiveness. If an estimate of the degradation of the mission effectiveness of a ship due to seakeeping could be made for alternatives during the feasible design stage, this would give the designer the ability to include, even though to a very limited extent, the effects of seakeeping in the selection of a "best" alternative design.

This thesis presents one approach to estimating the mission performance degradation<sup>a</sup>, termed mission effectiveness, and proposes a modified feasible design process incorporating this approach. The author shows how the modified process could be applied to a monohull, and illustrates the application with a numerical example.

## CHAPTER 2

### A DEFINITION OF MISSION EFFECTIVENESS

A measure of a ship's seakeeping ability, as seakeeping is defined above, is a measure of how effectively a mission is performed on the open ocean in the presence of waves and other natural environmental factors. Relative mission effectiveness is the ratio of the ship's ability to carry out a mission in a specified sea state to the ship's ability to carry out that same mission in calm water. This will generally be referred to as mission effectiveness or performance. The specific criteria for measuring effectiveness will vary from mission to mission. In each case, though, the relative effectiveness is a dimensionless ratio.

#### A PROPOSED MODEL FOR A MISSION STRUCTURE

A mission is a complex operation which can be described in simplest terms by a single word or short phrase such as "transport cargo", "transport passengers", "conduct anti-submarine warfare", or "conduct search and rescue". These complicated operations can be broken down into several simpler operations, or functions. Many functions may

themselves be complicated operations and can be further broken down into sub-functions. Several functional levels may be described until, at some point functions can be related to equipment or subsystems which perform them.

If a mission is viewed as a system of functions, and if the functions are treated as independently degraded by ship motions, then the method used for computing system reliability for RMA analysis can be used to calculate mission effectiveness [4]. Mission effectiveness is the product of the effectiveness of the different functions which make up the mission. The functions which perform a mission are performed either in series or in parallel. For the purposes of determining mission effectiveness, a mission can be diagrammed in the same way a system of components would be diagrammed for the purpose of making a system reliability calculation.

#### HOW FUNCTIONS ARE RELATED TO EACH OTHER IN THIS MODEL

Functions are performed either in series or in parallel. The actual determination of which functions are in series with each other and which are in parallel are very much a matter of experience and good judgement. One criterion which can help is to ask if a mission could be performed if a particular function could not be performed at all. If the mission would

fail, then that function is in series with other functions. If the mission could still be carried out, then the function is in parallel with other functions.

Several functions or sub-functions may be grouped together in parallel and this group in turn may be part of a serial group, or vice versa. Groups may be nested inside of groups. Then in order to make the effectiveness calculations, the value for the innermost group must be calculated first. The hypothetical mission graphed in figure (2-1) is an example. The

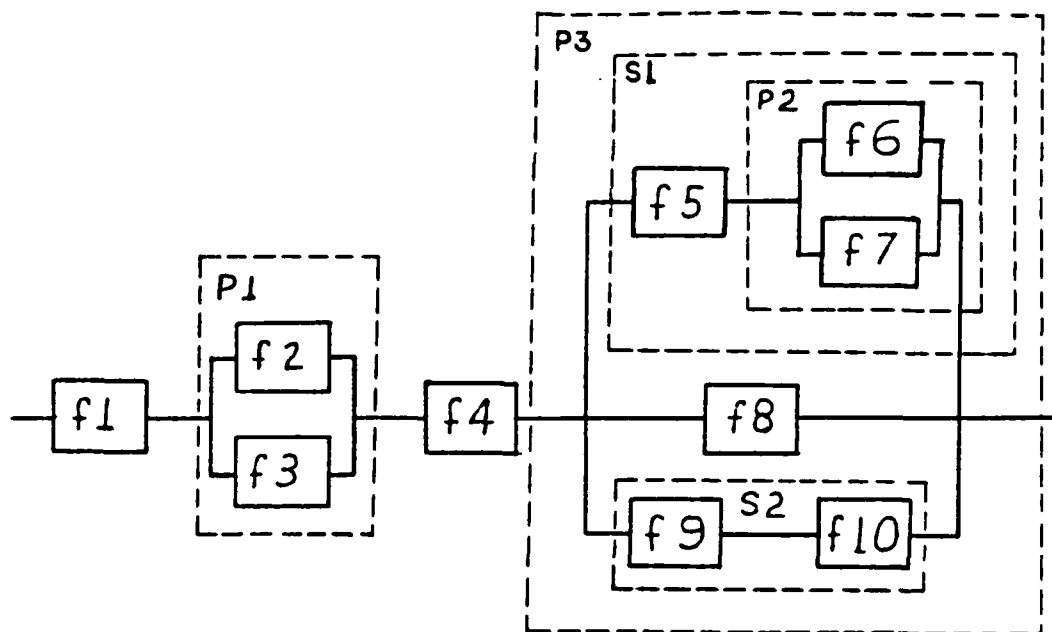

FIGURE (2-1)

A HYPOTHETICAL MISSION STRUCTURE

mission is represented by ten functions or sub-functions, f1 through f10. There are five subgroups; P1 consisting of functions f2 and f3, P3 consisting of subgroups S1, S2, and function f8, and S1 consisting of f5 and P2, and so on.

#### SUBSYSTEMS AND THEIR RELATION TO FUNCTIONS

Actual performance of functions is done by subsystems, equipment and personnel. Hereafter, the term subsystem will include personnel. Just as several functions may perform a mission, several subsystems may perform a particular function. The same process of determining the series-parallel relationships of the functions in a mission to each other may be applied to several subsystems which perform a single function.

If the performance of a subsystem or piece of equipment is degraded by the motions of the ship, the effectiveness of the function performed by that particular subsystem is also degraded. The mission effectiveness is also degraded. The definition of relative mission effectiveness introduced at the beginning of this chapter can also be applied to the performance of subsystems. The relative performance of a subsystem is the ratio of its actual performance when degraded by ship motions to its performance under calm water conditions.

A performance degradation function is the

correlation of this relative performance, or degraded performance to some significant measure of the motion which causes it. The information that is available currently for the performance degradation of existing subsystems is sketchy at best. It is often based on the only observations available, the reports and comments of the operators. About the only effectiveness carefully studied is human performance, which is significantly nonlinear. Other studies have focused on complex functions, such as fuelling at sea which has many steps in its execution. Many other performance degradation "functions" consist of two points on a plot of percent effectiveness versus some motion amplitude. One point is the largest reported amplitude with "satisfactory" or fully effective performance, the other is a reported amplitude where the performance could not be performed at all. A straight line between these two points constitutes the best guess (and this is recognized and openly admitted as a best guess) [5] as to the performance degradation of a particular activity or function. Efforts are underway to gather more accurate data and to formulate better ways to gather data [5].

#### CALCULATION OF RELATIVE MISSION EFFECTIVENESS

Calculation is performed by taking the product of the quantitative values of a function's effectiveness.

For functions in series:

$$E = \prod_{i=1}^n e_i \quad (2-1)$$

and for functions in parallel:

$$E = 1 - \prod_{i=1}^n (1-e_i) \quad (2-2)$$

Once the values of effectiveness for each individual function has been determined, the value of the effectiveness of any subgroups must be determined before the effectiveness of the mission can be calculated.

Referring to the hypothetical mission in figure (2-1) as an example, first the effectiveness for functions f1 through f10 must be calculated separately. Then the effectiveness for blocks P2 and S2 are calculated. Let  $V_i$  be the value of individual effectivenesses:

$$V_{P2} = 1 - (1-V_{f6})(1-V_{f7}) \quad \text{and}$$

$$V_{S2} = V_{f9}V_{f10}$$

Next the effectiveness for block S1 can be computed:

$$V_{S1} = V_{f5}V_{P2}$$

Now the effectiveness for the block P3 can be computed

$$V_{P3} = 1 - (1-V_{S1})(1-V_{f8})(1-V_{S2})$$

$V_{P1}$  is likewise calculated, then the relative mission

effectiveness is

$$E = V_{f1}V_{p1}V_{f4}V_{p3}$$

where E is the effectiveness of the hypothetical mission relative to its calm water performance.

## CHAPTER 3

### A MODIFIED FEASIBLE DESIGN PROCESS

The overall design process is composed of several phases of which the feasible design stage is the first. The goals at this stage of the design process are to first, eliminate designs and concepts which will not meet the requirements and constraints, and second, choose that alternative which will best meet the requirements and still remain within the limits set by the constraints.

The feasible design process proposed here is shown graphically in figure (3-1). A brief synopsis follows. Mission requirements are considered a given input. The necessary functions which support and carry out the mission must be derived from the requirements. The series - parallel structure of the functional relationships must be developed. Equipment and subsystems must be selected from what is available or expected to be available when the ship is produced. These subsystems, along with performance criteria form the input to a ship synthesis model which takes the payload and performance criteria and calculates a

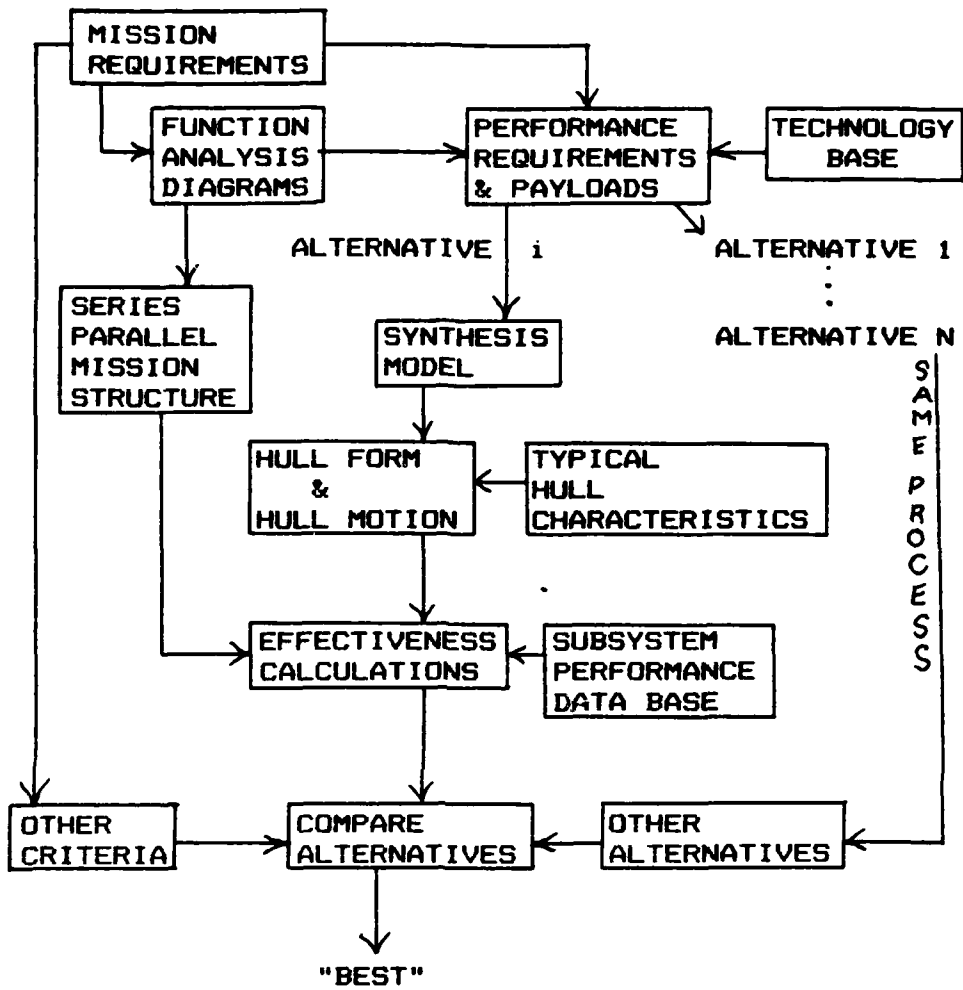

FIGURE (3-1)

PROPOSED FEASIBLE DESIGN PROCESS

This representation emphasizes where the estimation of seakeeping performance fits. It does not show all details of the design process.

preliminary estimate of the ship's physical characteristics. A hull form for the ship is developed and its motion response to waves calculated. The performance degradation of the subsystems resulting from the ship's motions is found and the mission effectiveness is estimated. Alternative hull types and subsystems will give rise to several alternatives which are evaluated in the same way. Their performance, along with how well the alternatives meet other non-seakeeping criterion are compared, and the one that appears best is selected for further design development.

#### MISSION REQUIREMENTS

The process for designing a new ship in the U.S. Navy begins with setting requirements for force levels based on national foreign and strategic policy. The mission requirements for a ship are then based upon where this ship design is expected to fit in our naval forces. The Mission Requirements must next be analyzed and mission areas defined. Specific mission areas may be listed as part of the mission requirements. Alternatively, the mission requirements may indicate that the new design is to replace or be similar to an existing class of ships.

#### DETERMINATION OF FUNCTIONS TO PERFORM THE MISSION

The first step in determining the effectiveness of

a mission is to determine what separate steps, or functions are performed in carrying out the mission. A standard list of mission areas which must be performed by U.S. Navy ships is a part of OPNAV 3501.2E(U), reference [6]. This also subdivides the mission areas into the capabilities necessary to carry out these missions. In light of the extensive breakdown of missions into their necessary functions which it provides, the determination of functions should be straightforward. If, for some reason determining the necessary functions is not, functional flow diagramming techniques [8][9] can also be used to identify the individual functions necessary to carry out the mission, and the relationships between functions. A top level, or gross operational level functional flow diagram is developed from the mission requirements. Then each function can be broken up into sub-functions and diagrammed in greater detail, if necessary.

#### DETERMINATION OF THE MISSION STRUCTURE

Once the functions which perform the mission have been identified, the series - parallel relationships can be developed as described in chapter 2. A diagram illustrating the functional relationships for each mission may be found to be helpful for this step.

#### SELECTION OF SUBSYSTEMS

Having listed and diagrammed the functions, the

actual subsystems must be selected. There may be several candidate subsystems capable of performing any particular function. Several lists of subsystem which make up the various feasible alternatives should be made. To illustrate, suppose a mission has four functions F1 through F4. It is determined that the mission could not be accomplished at all if F1 cannot be accomplished, but F2, F3, or F4 could fail completely and the mission could still be performed. Furthermore it is determined that F4 cannot be accomplished if F3 cannot be. Thus F3 is in series with F4, this pair is in parallel with F2, and F1 is in series with these as shown in figure (2-2).

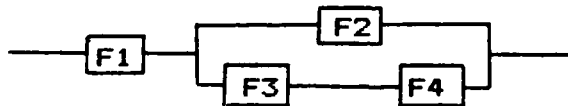

FIGURE (2-2)

ILLUSTRATION OF SERIES-PARALLEL MISSION STRUCTURE

Further, suppose there are two major alternative hull types. In selecting subsystems to perform F1, there are two alternative subsystems, but due to some limitation peculiar to one hull type, only the first subsystem can be used on it. For the second hull type, however, there are now two feasible alternatives, one with the first subsystem and one with the second.

Suppose now the second subsystem has features which cause the designer to want to explore an alternative with two of them installed. Either one can effectively perform the function F1, so the subsystems are in parallel. This relationship is shown in Figure (2-3).

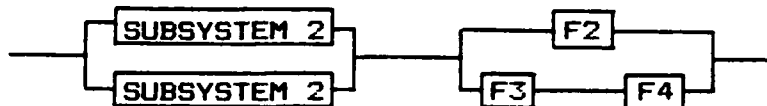

FIGURE (2-3)

#### SERIES PARALLEL MISSION STRUCTURE INCLUDING SUBSYSTEMS

There are now four alternative designs based around function F1, the hull types and the subsystems. For the first hull type there is one possible subsystem, and for the second hull type there are three possible combinations. As subsystems are selected for the other functions the list of alternatives will grow. Upon completion of this process for every mission and function, the designer has a set of alternative ship system specifications or lists of subsystems.

#### SYNTHESIS OF SHIP DESIGN ALTERNATIVES

The lists of subsystems are not yet descriptions of alternative ship designs. A great deal of information must yet be calculated from the lists. All of the subsystems have weight and take up volume. In addition many have electrical power, heating, cooling and

ventilating requirements. The size of the support systems must be calculated from these requirements, and the size of the ship to hold all this plus the propulsion plant, fuel, food and stores must be estimated before an alternative ship design is defined.

Synthesis models are series of calculations which calculate the characteristics and dimensions of a ship from the performance requirements such as maximum top speed, endurance range and speed, type of propulsion and electrical plants, and the list of payload items. A synthesis model is the first iteration on the design. A ship synthesis model should produce enough information about the ship's physical characteristics to allow the designer to determine, either through direct comparison of ship characteristics or through further analysis of those characteristics whether that design is feasible and whether it is better or worse in comparison to other alternatives.

For the estimation of relative mission effectiveness the synthesis model must produce enough information about the ship's hull to develop a hull form. At a minimum this will include displacement and overall dimensions of the hull. Depending on the hull type and method of developing the hull shape, other dimensions or coefficients of form may be required and must be produced by the synthesis model.

## DEVELOPMENT OF A HULL SHAPE

The response of a ship to the ocean waves depends upon the shape of the hull.

The final hull form will be a compromise between optimizing for arrangements, minimum resistance at top and cruise speeds, seakeeping, stability, and other limitations which may arise such as a maximum limit on draft for various ports. None of this can be accurately predicted at this early stage, so a "prototype" hull form should be used for the calculation of ship motions. This hull will not have the same shape as the final hull, nor will its response be identical, either. The primary criterion is that the hull shape conform to physical hull parameters produced by the synthesis model, and that there be enough information about the shape to permit the calculation of the ship's motions.

## ASSIGNMENT OF SUBSYSTEMS TO LOCATIONS

The amplitude of a ship's motions varies with location on the ship, the largest amplitudes being at the bow and stern and the smallest near the center of gravity of the ship. In order to predict the motions experienced by a subsystem, its location on the ship must be known. There are several problems, however, with fixing exactly the locations of subsystems.

First, the locations will almost certainly change due to revisions and compromises necessary for a variety of reasons which will only come to light later in the design process. Second computing the motion for every location would involve a very large computational effort. Third, the motions at a location will not be identical to the final design motions because the hull shape being used is not the same as the final hull shape, as stated previously. There must be a balance between making the computations reasonable, and accuracy. Only a few representative locations should be chosen. Equipment and subsystems are assigned to those locations that they will be closest to, and once the motions are computed, the motion for the appropriate station is used to compute performance degradation for a subsystem.

Some subsystems are constrained to particular locations. Hull mounted sonars are placed at or near the bow to be as far away from propeller and machinery noise as possible. Towed sonars must be deployed from the stern to avoid entanglement in the propeller. Helicopters must land aft of the deckhouse and masts. Radar and communication antennas are generally placed amidships for complete coverage of the horizon. Weapons launchers go wherever they can give the widest coverage. These constraints must be kept in mind when

assigning locations.

#### CALCULATION OF SHIP MOTIONS

Current techniques are all numerical, and are capable of computing a ship's motions for only one combination of speed, sea state and relative wave heading at one time. Consequently, motion calculations are repetitive and extremely time consuming to perform by hand. Any program which allows specification of speed, sea state, hull form and location for computation of motion and computes the necessary motions information required by the subsystems' performance degradation functions may be used for ship motion calculations.

#### CALCULATION OF RELATIVE MISSION EFFECTIVENESS.

At this point the designer has the series-parallel structure of the mission relating the subsystems to functions and then to the mission, and motions of locations near where the subsystems are expected to be for each speed, sea state, and wave heading combination. For each of these combinations, one after the other, the relative performance of each subsystem is determined from its performance degradation function. The mission effectiveness is calculated using equations (2-1) and (2-2).

The designer now has a set of relative mission effectivenesses for a set of sea conditions for a design alternative. The process is repeated for all

the alternatives, and the seakeeping results become part of the information to be assessed when deciding which alternative is the "best."

CHAPTER 4  
ILLUSTRATION OF THE PROCESS FOR A SINGLE MONOHULL  
DESIGN

To illustrate this approach, several existing programs were used and one program was written. The existing programs are as follows: A ship synthesis program to compute ship characteristics based on performance requirements and a given set of payloads. Two programs are used which calculate a "typical" hull form, and two programs which use the hull form program output and calculate the ship's response to long crested head seas. The program which was written performed the calculations for mission effectiveness. The output is a value for relative effectiveness of a mission area at a given speed in a given sea state for head seas.

MISSION STRUCTURE

This illustration, which is described further in Appendix I, used a simplified set of mission requirements. The mission requirements document which is reproduced in Appendix I specified warfare and supporting mission areas, and physical and performance

constraints on the design. Each mission area was broken down into major functions and its series - parallel mission structure developed by following the guidelines in chapter 2. There is no automated procedure for developing this mission structure. The mission structure was developed manually by the author.

Subsystems were next selected. Three criteria were used by the author in choosing the subsystems. First, that they performed the function, second that they were likely to meet the other non-seakeeping requirements, and third, they were in the data base for the synthesis model that was used. The subsystems were then substituted into the functions and the mission structure expanded, and, in some cases revised. It was found that certain subsystems performed more than one function. When this happened, the two separate functions were combined, and performed by one subsystem. The mission diagrams can be found in Appendix I, along with the complete equipment list.

#### SYNTHESIS OF THE DESIGN

For conventional monohull ships, there are a number of computer programs which perform the synthesis calculations. The one readily available to the author was the REED model [10] and it was selected for use in this illustration of the general procedure. The REED model is a regression based program which meets the

necessary requirements of a ship synthesis model; it produces the ship's hull form characteristics necessary for the development of a hull form, plus information which allowed the author to compare that alternative to the other non-seakeeping constraints specified by the mission requirements.

#### SHIP MOTIONS

For a conventional monohull, the method selected for producing a prototype is the use of the two programs, PREHULL and HULGEN. The inputs are length, beam, draft, prismatic and sectional area coefficients and depth of hull at midships. The result is a hull form which is not optimized in any particular way, but which conforms to standard US Navy design practices. This shape would be the starting point from which a designer would develop a hull.

HULGEN is capable of producing different files with different types of information about a hull. One of those files contains information on the sectional areas, design waterline and hydrostatic properties. This is the file used by POSTHULL to create the necessary input file for MOTION2D, both of which are further described below.

The locations chosen for the calculation of motions were station three for slamming, stations five, eight, fifteen and twenty for motions of displacement,

velocity and acceleration. Station five was chosen for equipment on the forecastle. Station eight was chosen because many sensors, the bridge and CIC are often forward of amidships. Slightly aft of midships are usually located main propulsion machinery which is largely insensitive to motion. Station twenty was chosen for the deployment of towed sonars and for landing helicopters, and station fifteen was chosen for equipment which may be in that vicinity. These locations are not necessarily the most representative choices, nor is five locations necessarily the best compromise between computation time and accuracy.

POSTHULL uses the output file from HULGEN as input and produces a properly formatted input file for MOTION2D [11]. The program uses a Lewis-form representation [12] which requires draft, maximum width and sectional area of each station. It computes the transfer function for heave and pitch by calculating the response of the ship to a series of waves of specified frequency and unit amplitude. It then computes the ship response spectrum for a given input spectrum, the vertical motions, velocity and acceleration spectra and statistics at specified locations along the length of the ship. The outputs are the response spectrums and the statistics of RMS, one third highest, and one tenth highest amplitude of

displacement, velocity and acceleration for each location, and expected frequency of slamming per hour.

#### MISSION EFFECTIVENESS CALCULATION

A program was written which implemented the procedure described in chapter 2. The program was written specifically to demonstrate this process and consequently does not have all the features the author considers necessary for regular use. It is included for completeness in Appendix III.

Each subsystem's location was input along with the type of motion which caused its performance to deteriorate. The appropriate motion for that location was found and used to compute the performance degradation from the subsystem's performance degradation function. The process for computing the mission effectiveness described in chapter 2 was implemented and the mission effectiveness for one sea state and two speeds calculated. The numerical results are in appendix I.

## CHAPTER 5

### CONCLUSIONS AND RECOMMENDATIONS

#### CONCLUSIONS

This illustration of the approach has demonstrated that it is possible to carry out the modified design process proposed in chapter 3. Calculations can be performed in a reasonable time through the use of computer programs to carry out the numerical computations.

The actual mission effectiveness procedure is not directly linked to any synthesis, hullform generation, or ship's motions calculation procedures. The purpose of those three steps is to compute a set of motions for a ship which will carry the subsystems. However, for the complete evaluation of an alternative on both seakeeping and non seakeeping criteria a synthesis model of some form is essential.

The value produced by this approach is more of a figure of merit than a true measure of the ability of a ship to perform a mission in a given set of sea conditions relative to calm water. Because the hull and the locations of subsystems cannot be expected to

be identical to the final design, the actual mission effectiveness cannot be expected to be the same. For two alternative designs which compare closely, a small difference in value would be meaningless.

The lack of firm performance degradation information on subsystems severely limits the usefulness of this approach. Until such time as there is more accurate data on subsystems, it is the author's opinion that the approach be used with great caution, and should not be relied upon solely when evaluating alternative designs.

#### RECOMMENDATIONS

Efforts are underway to collect better information on the performance degradation of subsystems. This work should be continued.

The mission structure is, to a great extent, independent of scenario. In different scenarios for a mission, different subsystems may be used, and one or more may not be used at all. While placing subsystems in parallel implies that the performance of all of them is not necessary to complete a mission, the underlying assumption is that any of the parallel subsystems is equally capable of performing its function. This may not be true. The effect of this assumption on the mission effectiveness needs to be studied carefully.

Further work on implementing this procedure with

other types of hull shapes should be carried out to provide the designer with the tools to compare different alternatives.

This procedure should be implemented for use with the design tools already in place at NAVSEA.

## REFERENCES

1. Bales, S.L. "Designing Ships To The Natural Environment," Naval Engineer's Journal, Vol. 95, No. 2, March, 1983.
2. Comstock, E.N. and R.J. Keane, "Seakeeping By Design," Naval Engineer's Journal, Vol. 92, No.2 April, 1980.
3. Bales, N.K. "Optimizing The Seakeeping Performance Of Destroyer-Type Hulls," 13th Symposium Naval Hydrodynamics, Shipbuilding Research Association, Japan, Tokyo, 1980.
4. Hosoda, R., Y. Kunitake, H. Koyama, and H. Nakamura "A Method for Evaluation of Seakeeping Performance in Ship Design Based on Mission Effectiveness Concept," 2ND internl. Sympo. on Practical Design in Shipbuilding Tokyo & Seoul, 1983.
5. Naval Sea Systems Command, "Motion Induced Degredation Of Subsystems," NAVSEA Report 3213-79-24, September, 1979.

6. Chief of Naval Operations, "Naval Warfare Mission Areas and Required Operational Capability / Projected Operational Environment Statements (U)," OPNAV Instruction C3501.2E, 19 October, 1977.
7. Blanchard, B.S., and W. J. Fabrycky, Systems Engineering And Analysis, Prentice-Hall, 1981.
8. McCandliss, R.K. "The Application Of Functional Flow Diagramming To Weapon Systems And Ships For Destroyer Missions," NSRDC Technical Note, OTD-070-1, December, 1967.
10. Reed, M.R. Ship Synthesis Model For Naval Surface Ships, Thesis, Dept. Ocean Engineering, Massachusetts Institute of Technology, May, 1979.
11. Loukakis, T.A. Computer Aided Prediction Of Seakeeping Performance In Ship Design, MIT Report No. 70-3 (Aug.1970).
12. Lewis, F.M. "The Inertia Of The Water Surrounding A Vibrating Ship," Transactions, SNAME, Vol. 37, 1929.

## BIBLIOGRAPHY

1. "Seakeeping In The Ship Design Process," Report Of The Seakeeping Workshop At The US Naval Academy, NAVSEA Research and Technology Directorate Report, July, 1975.
2. Newland, D.E. An Introduction To Random Vibration And Spectral Analysis, Logmon Group Limited, 1975.
3. Kehoe, J.W., K.S. Brower, and Comstock E.N. "Seakeeping and Combat System Performance - The Operators' Assessment." Naval Engineer's Journal, Vol. 95, No. 3, May, 1983.
4. Bales, S. L., W.T. Lee, and J. M. Voelker, Standardized Wave and Wind Environments for NATO Operational Areas, DTNSRDC/SPD-0919-01, July, 1981.
5. Cox, G.G. and A.R. Lloyd, "Hydrodynamic Design Basis for Navy Ship Roll Motion Stabilization," Transactions, SNAME, Vol. 85, 1977, pp 51-93.

6. Barr, R.A., and V. Ankudinov, "Ship Rolling, Its Prediction And Reduction Using Roll Stabilization," Marine Technology, Vol. 14, No. 1, Jan., 1977, pp 19-41.
7. Lewis, E.V. "The Motion Of Ships In Waves," Principles Of Naval Architecture, J.P. Comstock, ed., SNAME, New York, 1967, pp 607-715.
8. Price, W.G. and R.E.D. Bishop, Probabilistic Theory Of Ship Dynamics, John Wiley & Sons, New York, 1974.
9. Bales, S.L., W.T. Lee, and J.M. Voelker, Standard Wave And Wind Environments For NATO Operational Areas, DTNSRDC/SPD-0919-01, July, 1981.
10. Pierson, W.J. and L. Moskowitz, "A Proposed Spectral Form For Fully Developed Wind Seas Based On The Similarity Theory Of S.A. Kitaigorodsku," Tech. Report, U.S. Naval Oceanographic Office, Contract No. 62306-1042, 1963.

11. Bales, S.L. and E.W. Foley, "Atlas Of Naval Operational Environments: The Natural Marine Environment," Report DTNSRDC/SPD-0795-01, Sept. 1979.
12. Gerritsma, J. and W. Beukelman, "Analysis Of The Modified Strip Theory For The Calculation Of Ship Motions And Wave Bending Moments," International Shipbuilding Project, Vol. 14, 1967, pp 319-337.
13. Vugts, J.H. "The Hydrodynamic Forces And Ship Motions In Oblique Waves," Netherlands Ship Research Center Report No. 150S19.
14. Salveson, N., E. O. Tuck and O. Faltinsen, "Ship Motions And Sea Loads," Transactions, SNAME, Vol. 78, 1970.
15. Parker (Jr.), J.T., "Development Of Requirements," Naval Engineer's Journal, Vol. 93, No.3, June, 1981.

## APPENDIX I

### EXAMPLE OF THE APPROACH

#### MISSION REQUIREMENTS

In order to demonstrate how the mission effectiveness calculation process can be applied to feasibility studies, a highly simplified feasibility study is described here. It begins with a set of mission requirements and constraints which are taken from an example given in a Combat Systems Design course, taught in the summer of 1983. The directions are reproduced here.

#### DESIGN DIRECTION FOR "LOW MIX" SURFACE COMBATANT

##### 1. Mission Statement

The "low mix" Surface Combatant is to be a replacement for the FF 1040, FFG 1, FF 1052 Class frigates. This ship's primary mission will be to escort low value naval task forces (replenishment and amphibious) and mercantile fleets in relatively low-threat environments. The primary threat is from diesel and nuclear submarines.

## 2. Performance Requirements

- a. ASW - Defend task force against enemy attack submarines.
- b. AAW - Limited defense for task force. Point defense for own ship.
- c. SUW - Defend task force against surface forces. Shore bombardment.
- d. C<sup>3</sup>I - assist in control of task force/mercantile force assuming presence of at least one mid mix ship serving as force commander.
- e. Mobility - Maximum sustained speed - 28 knots (baseline). Minimum range 4,500 NM at 18 knots.
- f. UNREP - Refuel and receive stores and munitions while underway.

## 3. Constraints

- a. Acquisition Cost - This ship will be needed in large numbers to replace retiring assets. A follow ship acquisition cost constraint of \$300M (FY 80) is established.
- b. Ship Displacement - full load displacement will not exceed 4000 tons.
- c. Manning - Number of accommodations will not exceed 225.

Performance requirements a through f above are mission areas. Three mission areas are considered supporting mission areas; they are Mobility (MOB), Underway Replenishment (UNREP) and Command, Control, Communications, and Intelligence gathering (C<sup>3</sup>I). All three warfare areas are diagrammed in parallel. As long as the ship is capable of performing one mission, it is still capable of performing some part of its overall mission as escort. This is an arbitrary decision made primarily to simplify this illustration of the process. It is quite possible that some other emphasis (ie ASW is essential to perform the entire mission) on warfare areas would be equally correct.

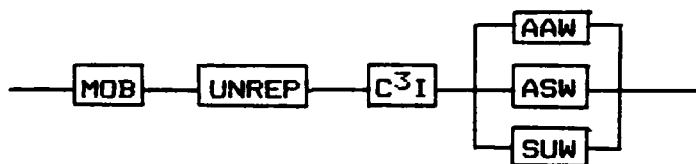

FIGURE (A-1)

#### TOP LEVEL FUNCTION DIAGRAM

#### FUNCTIONAL FLOW DIAGRAMS

The top level series-parallel functional relation diagram is shown in figure (A-1). Convoy escort is considered to be impossible to carry out without any mobility, or without any ability to

replenish while underway, or with no communications capability. The ship can still perform its mission, although in a degraded capacity if any one or even two of the warfare mission areas could not be performed. A rather critical assumption is that a particular warfare area, say Anti-Submarine Warfare (ASW) will not always be necessary. The choice of which functions must be performed is a matter of judgement on the part of the designer. Two equally acceptable alternatives to the parallel relation are: 1) that all three warfare mission areas would be in series. 2) since the primary threat is submarines, ASW is in series and that Anti-Air Warfare (AAW) and Surface Warfare (SUW) are in parallel.

There are five basic functions common to all three warfare areas (figure A-2) detection, identification, tracking, engaging or attacking, and evaluating the attack for success. In each warfare area these functions are performed different subsystems. All five functions are considered vital; no one function can fail completely without the warfare capability



FIGURE (A-2)

DIAGRAM OF FUNCTIONS NECESSARY TO EACH WARFARE AREA

failing completely.

#### SELECTION OF SUBSYSTEMS FROM TECHNOLOGY BASE

At this point it becomes necessary to use the available technology base, the data base for the Reed ship synthesis model. In conjunction with developing the functional relationships, selection of specific subsystems for the synthesis model are done for one alternative. The complete list of subsystems for the warfare mission areas is shown in table (A-1). The list of subsystems, along with the performance parameters were input to the REED model. The resulting REED model output is shown in appendix II.

The subsystems were incorporated into separate series-parallel functional diagrams for each mission. The resulting diagrams are shown in figures (A-3) through (A-5). The relationships shown are not necessarily the only possible relationships.

Some of the subsystems depicted in these diagrams are actually functions. An example is launching and recovering a helicopter. This involves the hull, on which the helicopter lands, support personnel on the ship, the helicopter, and its pilot. The operation is generally viewed as a single function or subsystem, and performance degradation is estimated for the entire operation, not for the many steps involved [5]. The

FUNCTION	SUBSYSTEM
ASW	
DETECT, IDENTIFY	SQS-56 sonar
TRACK, EVALUATE	SQR-19 sonar
	2 LAMPS helos
ENGAGE	LAMPS
	MK-32 T.T.
AAW	
DETECT, TRACK	SPS-49 Radar
EVALUATE	SPS-10 Radar
IDENTIFY	IFF system
	SLQ-32
ENGAGE	NATO SEA
	SPARROW
	MK-86 GFCS
	MK-45 naval gun
	CIWS
SUW	
DETECT, TRACK	SPS-10 radar
TRACK, EVALUATE	LAMPS helo
	MK-86 GFCS
ENGAGE	MK-45 naval gun
	HARPOON ASCM

TABLE (A-1)

SUBSYSTEMS FOR THE DESIGN ALTERNATIVE

"subsystem" designated PERS, for personnel, is included where the subsystem is operated by personnel, and their performance can affect the function that the subsystem and personnel together perform. The signals processed by the sonar are evaluated by the sonar operators. That information is passed on to other personnel who combine it with information from other sources in identifying and tracking a target, and controlling an attack.

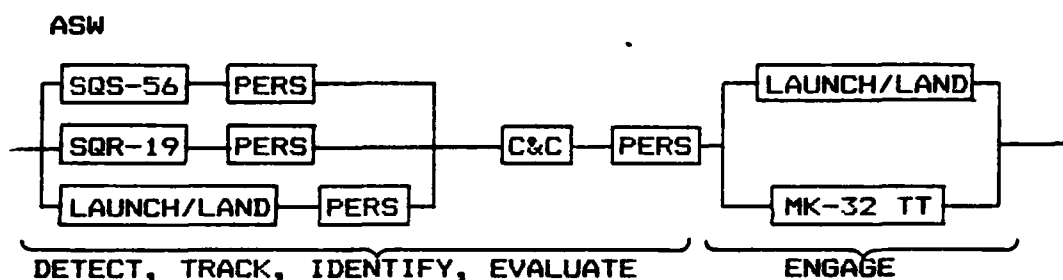

FIGURE (A-3)

ASW MISSION EXPANDED INTO ITS COMPONENT SUBSYSTEMS

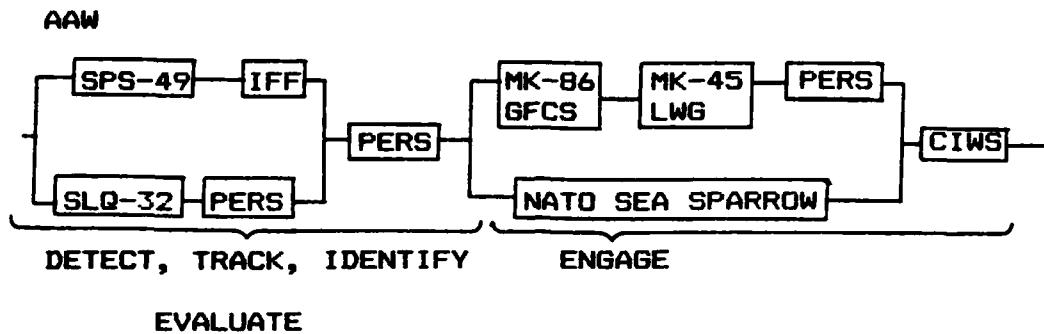

FIGURE (A-4)

AAW MISSION EXPANDED INTO ITS COMPONENT SUBSYSTEMS

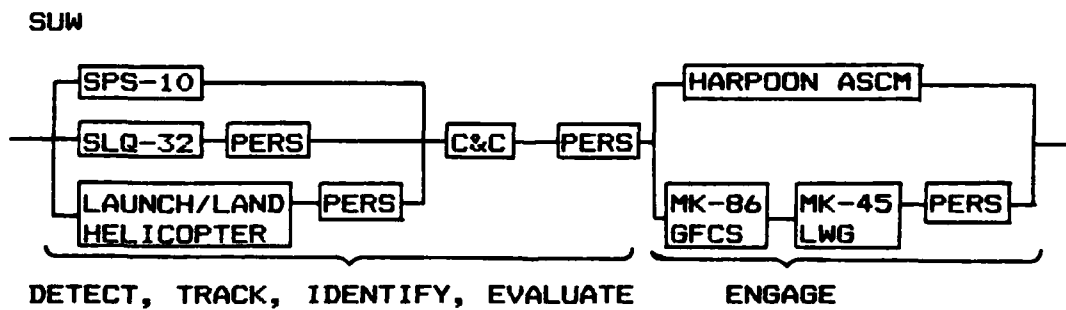

FIGURE (A-5)

SUW MISSION EXPANDED INTO ITS COMPONENT SUBSYSTEMS

Two programs are used to generate a hull form. The first is PREHULL which accepts the basic hull parameters of length, beam draft, depth of hull at station ten, and the prismatic and midship section coefficients, and creates an input file for HULGEN, which is an interactive hull form generation program. Both of these (as well as POSTHULL and MOTION2D, used in the motion calculations) are part of the NAVSEA Hull Form Design System currently used for preliminary hull design. The file produced by PREHULL describes a conventional monohull which conforms to standard Navy design practices. The output of the HULGEN programs forms the input to the programs which compute ship's motions.

Five locations for calculating motions for subsystems were chosen for this demonstration. The locations were: Station five, one quarter of the ship's length from the bow for equipment on the forecastle, Station eight for combat systems, CIC equipment, and equipment on masts, etc. Stations fifteen and twenty for equipment aft, particularly helicopter launching and landing, and towed sonar systems.

SYSTEM/FUNCTION	STATION
SQS-56	(none subject to slamming)
SQR-19	20
LAMPS helicopter	15
MK-32 Torpedo Tubes	8
SPS-49	8
SPS-10	8
SLQ-32	8
MK-86 GFCS	8
NATO SEA SPARROW	20
MK-45 LWG	5
CIWS	15
HARPOON ASCM	5
UNREP	8

TABLE (A-2)

LOCATION OF MAJOR SUBSYSTEMS

For this example the MOTION 2D [11] program was used to compute ship response to waves. The program is limited to long crested head seas, and the Pierson Moskowitz sea spectrum formula was used to generate spectra.

CALCULATION OF MISSION EFFECTIVENESS

Up to this point, all three missions have been dealt with in order to fully illustrate the process. The process of calculating mission effectiveness is

identical for each mission so only one, the ASW mission calculations will be shown here.

Normally, the designer would examine all sea state and speed conditions considered to be of interest or importance for comparison. Only two sample calculations were performed for sea state six, fully developed, long crested head seas, at five and fifteen knots. The procedure for both is identical, as is the procedure for any other set of sea states and speeds.

A program was written to demonstrate the calculation process. The program has three inputs to it. First, a list of the systems, whether they are in series or in parallel, and their assigned locations. Second, the vertical motions, velocities and accelerations of the ship at each of four stations plus expected frequency of slam. Third, performance degradation functions for the functions and subsystems.

It must be recognized that any subsystem not affected by motion need not be included in the diagram for the purpose of calculating mission effectiveness. The effects of motion on command control equipment, mainly communications gear, navigational electronics, and computers are negligible. The effects on the personnel who operate that equipment and evaluate information coming from it cannot be ignored, however. Results of the calculation are shown in figures (A-6)

and (A-7). They are summarized below

Mission	ASW	
Sea state	6	6
Speed (kts)	5	15
Effectiveness	1.0	0.58

The results are interpreted as follows. In sea state six, for a speed of five knots, the ship may perform the ASW mission about as well as in calm water. In sea state six, for a speed of fifteen knots, the ship may see a reduction in effectiveness of about half. The computer program is capable of producing seven or more digits of accuracy. On the other hand, the data and the assumptions involved with the procedure reduce the accuracy greatly.

THE EFFECTIVENESS RELATIVE TO THIS FEASIBLE  
DESIGN CALM WATER PERFORMANCE IS

1.00

EQUIPMENT/SUBSYSTEM WITH WORST PERFORMANCE  
HELD FLTDECK

NAME  
RELATIVE EFFECTIVENESS 0.51

SYSTEM LIST	ELEMENT	SER/PAR	BLOCK/ELEMENT	EFFECTIVENESS
BLOCK	DETECT	S	B	1.00
ASW	PERSONNEL	S	E	1.00
ASW	ENGAGE	S	B	1.00
ASW	HULL SONAR	P	B	1.00
DETECT	TOWED SONAR	P	B	1.00
DETECT	HELD OPS	P	B	0.51
ENGAGE	HELD OPS	P	B	0.51
ENGAGE	MK-32 TT	P	E	1.00
HULL SONAR	SQS-56	S	E	1.00
HULL SONAR	PERSONNEL	S	E	1.00
HULL SONAR	SQR-19	S	E	1.00
TOWED SONAR	PERSONNEL	S	E	1.00
TOWED SONAR	HELD FLTDECK	S	E	1.00
HELD OPS	PERSONNEL	S	E	0.51
HELD OPS	PERSONNEL	S	E	1.00

FIG (A-6)

MISSION EFFECTIVENESS, FIVE KTS. SEA STATE SIX

THE EFFECTIVENESS RELATIVE TO THIS FEASIBLE  
DESIGN CALM WATER PERFORMANCE IS

0.58

EQUIPMENT/SUBSYSTEM WITH WORST PERFORMANCE  
NAME HELD FLTDECK  
RELATIVE EFFECTIVENESS, 0.47

SYSTEM LIST	ELEMENT	SER/PAR	BLOCK/ELEMENT	EFFECTIVENESS
BLOCK	DETECT	S	B	0.91
ASW	PERSONNEL	S	E	0.75
ASW	ENGAGE	S	B	0.85
ASW	HULL SONAR	P	B	0.75
DETECT	TOWED SONAR	P	B	0.45
DETECT	HELD OPS	P	B	0.36
DETECT	HELD OPS	P	B	0.36
ENGAGE	MK-32 TT	P	E	0.76
ENGAGE	SQS-56	S	E	1.00
HULL SONAR	PERSONNEL	S	E	0.75
HULL SONAR	SGR-19	S	E	0.60
TOWED SONAR	PERSONNEL	S	E	0.75
TOWED SONAR	HELD FLTDECK	S	E	0.47
HELD OPS	PERSONNEL	S	E	0.75
HELD OPS	PERSONNEL	S	E	0.75

FIG (A-7)

MISSION EFFECTIVENESS, FIFTEEN KTS. SEA STATE SIX

APPENDIX II  
REED MODEL OUTPUT

SHIP NUMBER 1

SHIP SPECIFICATIONS

VSUS	28.00	DELTA CF	0.00	CPD ACC	18.00
VEND	18.00		0.00	CREW ACC	190.00
RANGE	4500.00		0.00	FLAG ACC	0.00
LBP	0.00		0.00	TRP ACC	0.00
L/B	8.70		0.00	PASS ACC	0.00
B/H	3.10	SSEL TYP	1.00	DAYS DUR	45.00
CP	0.59	EMEL TYP	4.00		0.00
CX	0.80	NU LOWSD	0.00		0.00
	0.00	NU MEDSD	2.00		0.00
	0.00	NU HI SD	0.00		0.00
PROP FLT	3.00	NU GT GN	0.00	HULL MAT	1.00
SUS SHP	0.00	NU ST GN	2.00	SUFSTMAT	2.00
NU BOILS	2.00	KW/DIESL	1000.00		0.00
NU REACT	0.00	KW/GAS T	0.00	GM/B MIN	0.08
NU ENGS	1.00	KW/STM G	1000.00		0.00
NU SHAFT	1.00	ELC MARG	0.44	DISP TOL	10.00
PROPELLR	1.00		0.00	MXDIS IT	20.00
SHFT TYP	1.00		0.00	VCG TOL	0.10
PROP RPM	0.00		0.00	MXVCG IT	20.00
PROP DIA	0.00	HEAT TYP	1.00	DCWTMARG	0.10
DEPTH MB	0.00	FIN STAB	2.00	FS CORR	0.00
LENTH MB	0.00		0.00	FRNT TYP	0.00
BEAM MB	0.00		0.00	FRNTCNST	0.00
FC END	0.00	OFF ACC	0.00		0.00
FC MAXSP	0.00		17.00	PASSAGE	1.00
PROP FLT	PF1200ST	SHFT TYP	HOLLOW	HULL MAT	STEEL
SSEL TYP	STEAM	PROPELLR	FIXEDFIT	SUFSTMAT	ALUMINUM
EMEL TYP	MEDSPDIE	FIN STAB	YES	PASSAGE	CNTRLINE
		HEAT TYP	STEAM		

REED MODEL OUTPUT (CONTD)

SUMMARY OF RESULTS

LBP	410.86	DISP FLD	4038.47	FLD DENS	19.81
BEAM	43.37	DISP LSP	2579.03	LSP DENS	12.65
DRAFT	16.59	VR LOADS	1201.54	WFAY/FLD	0.08
D 0	43.72	WT MARG	257.90	WFER/FLD	0.04
D 10	31.40	WTGRP 1	1251.40	WDPS/FLD	0.45
D 20	31.81	WTGRP 2	364.56	VFAY/VOL	0.28
D AVG	33.52	WTGRP 3	141.04	VFER/VOL	0.22
LEN R DK	0.00	WTGRP 4	151.39	VOFS/VOL	0.50
CP	0.59	WTGRP 5	358.47	WTG2/SHP	25.90
CX	0.80	WTGRP 6	246.81	VMB/SHP	3.50
VCG FLD	17.74	WTGRP 7	65.35	WT3/KWIN	78.98
VCG/DAVG	0.53	VOL TOT	456690.12	WTG1/VOL	6.14
L/B	9.47	VOL HULL	359502.50	WTG5/VOL	1.76
B/H	2.61	VOL SSTR	97187.62	VHAB/MAN	400.52
EXCES KG	0.00	CRUISEKW	1664.37	WHAB/MAN	633.87
RANGE	4500.00	BATTLEKW	1955.90	MEN/DISP	0.06
SUS SHP	31525.88	24 HR KW	1570.23	KWIN/FLD	0.99
END SHP	5320.79	NU LOWSD	0.00	SHP/DISP	7.81
VSUS	28.00	NU MEDSD	2.00	DF*V/SHP	24.68
VEND	18.00	NU HI SD	0.00	WVY*V/DF	2.38
AVSEASPD	25.90	NU GT GN	0.00		
NU ACCOM	225.00	NU ST GN	2.00		
KW INST	4000.00	KW/DIESL	1000.00		
KW SFSEK	2000.00	KW/GAS T	0.00		
KW EMERG	2000.00	KW/STM G	1000.00		

REED MODEL OUTPUT (CONTD)

PAYLOAD SPECIFICATIONS

QNTY	ITEM	QNTY	ITEM	QNTY	ITEM	QNTY	ITEM
1.00	2	1.00	192				
1.00	9	24.00	200				
1.00	23	1.00	204				
1.00	41	1.00	208				
1.00	55	1.00	209				
1.00	60	1.00	212				
8.00	64	2.00	213				
1.00	67	2.00	214				
1.00	75	2.00	215				
1.00	100	200.00	217				
1.00	105	20.00	219				
1.00	112	1.00	232				
800.00	121	1.00	242				
10000.00	125						
1.00	127						
2.00	141						
1.00	158						
1.00	165						
2.00	180						
1.00	189						

APPENDIX III  
MISSION EFFECTIVENESS CALCULATION PROGRAM

```

PROGRAM PERFORM
C
CHARACTER*64 SOURCE, MOTNS, DBLIST, DBASE, REPLY
CHARACTER*12 NAMES(50,2),DBLIS(100)
CHARACTER*1 TYPE(50,2)
INTEGER*2 ROWS, ISOURC, IMOTNS, IDBLIS, IDBASE
INTEGER*2 LOCATE(50,2),DBADDR(100),DBSIZE
REAL VALUES(50)
C
COMMON /INOUT/ ISOURC,IMOTNS,IDBLIS,IDBASE
COMMON /SYSTEM/ NAMES,TYPE,LOCATE,VALUES
COMMON /SYSDAT/DBSIZE,DBLIS,DBADDR
C
C ENSURE THAT CHARACTER VARIABLES ARE CLEARED AND HAVE ONLY BLANKS
C
CALL EMPTY (SOURCE)
CALL EMPTY (MOTNS)
CALL EMPTY (DBLIST)
CALL EMPTY (DBASE)
CALL EMPTY (REPLY)
C
WRITE (*,50)
50 FORMAT (//,' BEFORE ENTERING THIS PROGRAM YOU SHOULD HAVE HANDY',
& ' THE FILE',/, ' NAMES FOR THE DATA BASE, SHIP MOTIONS AND THE',
& /, ' SYSTEMS DIAGRAM, OR THE DIAGRAM IN HAND.')
```

```

C
WRITE (*,55)
55 FORMAT (//,' WILL YOU ENTER SYSTEM INFORMATION FROM TERMINAL ',
& 'OR FILE',/, ' TYPE IN WHICH?')
READ (*,60) REPLY
60 FORMAT (A64)
C
IF (REPLY .EQ. 'FILE') THEN
WRITE (*,65)
65 FORMAT (/, ' WHAT IS THE FILE NAME? ')
READ (*,60) SOURCE
ISOURC = 10
OPEN (ISOURC,FILE=SOURCE,STATUS='OLD')
READ (ISOURC,70)ROWS
70 FORMAT (8N,I10)
ELSE
WRITE (*,75)
75 FORMAT (/, ' ENTER THE TOTAL NUMBER OF ELEMENTS IN THE SYSTEM')
READ (*,70) ROWS
END IF
```

```

C
WRITE (*,80)
80 FORMAT (//,' WHAT FILE IS THE SHIP MOTIONS STORED IN? ')
READ (*,60) MOTNS
IMOTNS = 20
OPEN (IMOTNS,FILE=MOTNS,STATUS='OLD')
```

```
WRITE(*,90)
90 FORMAT(//,' WHAT IS NAME OF DATABASE FILE? ')
READ (*,60) DBASE
IDBASE = 30
OPEN (IDBASE,FILE=DBASE,STATUS='OLD',ACCESS='DIRECT',
&  FORM= 'FORMATTED',RECL=150)
C  UNLOCK (IDBASE)
READ (IDBASE, REC=1, FMT=60) DBLIST
IDBLIS = 40
OPEN (IDBLIS,FILE=DBLIST,STATUS='OLD')
READ (IDBLIS,70) DBSIZE
C
C  CALL MAINSUB(ROWS,REPLY)
C
C  END
C
```

```

C *****
C
C   SUBROUTINE MAINSUB(ROWS,REPLY)
C
C   CHARACTER*64 REPLY
C   CHARACTER*12 NAMES(50,2),DBLIS(100)
C   CHARACTER*1  TYPE(50,2)
C   INTEGER*2   LOCATE(50,2),ROWS,ISOURC,IMOTNS,IDBLIS,IDBASE
C   INTEGER*2   DBADDR(100),DBSIZE
C   REAL VALUES(50), EFFECTIVENESS
C
C   COMMON /INOUT/ ISOURC,IMOTNS,IDBLIS,IDBASE
C   COMMON /SYSTEM/ NAMES,TYPE,LOCATE,VALUES
C   COMMON /SYSDAT/DBSIZE,DBLIS,DBADDR
C
C   ENSURE THAT CRITICAL ARRAYS START OUT ZEROED OUT
C
C   CALL ZERO (ROWS)
C
C   GET THE SYSTEM LIST AND RELATIONSHIPS EITHER FROM FILE OR FROM
C   THE TERMINAL. STORE THE FILE IF DESIRED
C
C   CALL FILNAMS (ROWS,REPLY)
C
C   READ IN THE MOTIONS OF THE SHIP, CALCULATE THE PERFORMANCE
C   EFFECTIVENESS OF THE SEPARATE EQUIPMENTS OR SUBSYSTEMS
C
C   CALL GETMOT (ROWS)
C
C   PERFORM THE CALCULATION FOR MISSION EFFECTIVENESS
C
C   CALL MAINCALC (ROWS, EFFECTIVENESS)
C
C   WRITE THE OUTPUT TO A FILE
C
C   CALL OUTPUT (ROWS, EFFECTIVENESS)
C
C   RETURN
C   END
C

```

```

C *****
C
C   SUBROUTINE EMPTY(STR)
C
C   CHARACTER*64 STR
C
C   SET STR EQUAL TO BLANKS-THERE ARE 64 BLANKS
C
C   STR='
C   & '
C   RETURN
C   END
C
C *****
C
C   SUBROUTINE ZERO(ROWS)
C
C   CHARACTER*12 NAMES(50,2),EMPTY
C   CHARACTER*1 TYPE(50,2)
C   INTEGER*2 LOCATE(50,2), ROWS
C   REAL VALUES(50)
C
C   COMMON /SYSTEM/ NAMES,TYPE,LOCATE,VALUES
C
C   DO 1010 I=1,50
C     DO 1020 J=1,2
C       NAMES(I,J) = '
C       LOCATE(I,J) = 0
C 1020 CONTINUE
C       VALUES(I) = 0.0
C 1010 CONTINUE
C
C   RETURN
C   END
C

```

```

C *****
C
C   SUBROUTINE FILNAMS(ROWS,REPLY)
C
C   CHARACTER*64 REPLY,EMPTY
C   CHARACTER*12 NAMES(50,2),SOURCE
C   CHARACTER*1  TYPE(50,2)
C   INTEGER*2 LOCATE(50,2),ROWS,I,ISOURCE,INOTNS,IDBASE,IDBLIS
C
C   COMMON /INOUT/ ISOURCE,INOTNS,IDBLIS,IDBASE
C   COMMON /SYSTEM/ NAMES,TYPE,LOCATE,VALUES
C
C   WRITE (EMPTY,101)
101 FORMAT(64X)
C   SOURCE = EMPTY
C
C   IF (REPLY .EQ. 'TERMINAL') THEN
C     DO 2010 I=1,ROWS
10    WRITE (*,201)
201    FORMAT (//,' BLOCK NAME? ')
      READ (*,210) NAMES(I,1)
210    FORMAT (A12)
      IF ((I .GT. 1).AND.(NAMES(I-1,1) .EQ. NAMES(I,1))) THEN
        TYPE(I,1) = TYPE(I-1,1)
      ELSE
C
C        WRITE (*,203)
203    FORMAT (//,' IS THIS A SERIES OR PARALLEL BLOCK',/,
      &        ' TYPE S OR P ')
      READ (*,212) TYPE(I,1)
212    FORMAT (A1)
C
C      END IF
C
C      WRITE (*,202)
202    FORMAT (//,' ELEMENT NAME? ')
      READ (*,210) NAMES(I,2)
      WRITE(*,204)
204    FORMAT(//,' IS THIS ELEMENT ANOTHER BLOCK, OR EQUIPMENT',/,
      &        'SUBSYSTEM',/, ' TYPE B (BLOCK) OR E (EQUIPMENT)')
      READ (*,212) TYPE (I,2)
      WRITE (*,205)
      IF (TYPE (I,2) .EQ. 'E') THEN
205    FORMAT(//,' FOR APPROXIMATE LOCATION, TYPE THE MENU ',/,
      &        ' NUMBER YOU THINK THE EQUIPMENT/SYSTEM IS NEAREST')
      WRITE (*,206)
206    FORMAT(/,5X,' 1',5X,'NEAR BOW',/,5X,' 2',5X,'NEAR MIDSHIPS',
      &        /,5X,' 3',5X,'NEAR STATION 15',/,5X,' 4',5X,'AT STERN')
      READ (*,213) LOCATE(I,1)
213    FORMAT (BN,I3)
      ELSE
        LOCATE(I,1) = 0
      END IF
    END DO
  END IF

```

```

        END IF
C
20    WRITE (*,207) I
207   FORMAT (///,5X,'ROW ',I3,/,/, ' BLOCK',7X,'NAME',7X,
&     'SER/PAR TYPE LOCATION')
        WRITE (*,208) NAMES(I,1),NAMES(I,2),TYPE(I,1),TYPE(I,2),
&     LOCATE(I,1)
208   FORMAT(1X,A12,A12,3X,A1,7X,A1,7X,I3)
        WRITE (*,209)
209   FORMAT(/,' IS THE ABOVE CORRECT? TYPE Y OR N ')
        READ (*,214) REPLY
214   FORMAT(A)
        IF (REPLY .EQ. 'N') THEN
            GO TO 10
        ELSE IF (REPLY .EQ. 'Q') THEN
            GO TO 99
        ELSE IF (REPLY .NE. 'Y') THEN
            WRITE (*,901) REPLY
901   FORMAT(/,' YOUR REPLY ',A12, ' WAS NOT UNDERSTOOD')
            REPLY = EMPTY
            GO TO 20
        END IF
2010  CONTINUE
C
3010  TYPE *, ' '
        TYPE *, ' DO YOU WANT TO SAVE THIS IN A FILE?'
        TYPE *, ' TYPE Y OR N'
        READ (*,214) ANS
        IF (ANS .EQ. 'Y') THEN
            TYPE *, ' '
            TYPE *, ' WHAT IS FILE NAME?'
            READ (*,214) SOURCE
            ISOURCE = 10
            OPEN (ISOURCE, FILE = SOURCE, STATUS = 'UNKNOWN')
            WRITE (ISOURCE,450) ROWS
450   FORMAT(I5)
            DO I=1, ROWS
                WRITE (ISOURCE,350) NAMES(I,1),NAMES(I,2),TYPE(I,1),
&                 TYPE(I,2),LOCATE(I,1)
            END DO
        ELSE IF (ANS .NE. 'N') THEN
            TYPE *, ' '
            TYPE *, ' ANSWER NOT UNDERSTOOD'
            GO TO 3010
        END IF
C
        ELSE IF (REPLY .EQ. 'FILE') THEN
            DO 2020 I=1,ROWS
                READ (ISOURCE,350) NAMES(I,1),NAMES(I,2),TYPE(I,1),TYPE(I,2)
&                 ,LOCATE(I,1)
350   FORMAT(2A12.2(X,A1)I3)
2020  CONTINUE

```

```
END IF  
GO TO 999
```

```
C
```

```
99 WRITE (*,910)  
910 FORMAT (////,' ENDING PROGRAM.',//,' QUIT')  
STOP  
999 CONTINUE  
RETURN  
END
```

```
C
```

```

C *****
C
C   SUBROUTINE MAINCALC (ROWS, EFFECTIVENESS)
C
C   CHARACTER*12 NAMES(50,2)
C   CHARACTER*1 TYPE(50,2),DUMMY
C   INTEGER*2 PTR, STPTR, ISTACK(10), I, LOCATE(50,2),ROWS
C   REAL CURVAL,VALUES(50),RSTACK(10), EFFECTIVENESS
C
C   COMMON /SYSTEM/ NAMES, TYPE, LOCATE, VALUES
C
C   INITIALIZE VARIABLES
C
C
C   CURVAL = 0.0
C   PTR = 1
C   STPTR = 1
C
C   START CALCULATION LOOP
C
C   FIND END OF BLOCK
C
C 1 IF ((PTR+1 .LE. ROWS) .AND. (NAMES(PTR+1,1) .EQ. NAMES(PTR,1)))
C   & THEN
C     PTR = PTR+1
C     GO TO 1
C   END IF
C
C   IF THIS IS A BLOCK, THEN SET CURRENT VALUES AND STATUS ON THE
C   STACK AND START THE PROCEDURE AGAIN, RECURSIVELY
C
C 2 IF (VALUES(PTR) .EQ. 0.0) THEN
C   IF (TYPE(PTR,2) .EQ. 'B') THEN
C     ISTACK(STPTR) = PTR
C     RSTACK(STPTR) = CURVAL
C     CURVAL = 0.0
C     STPTR = STPTR + 1
C     CALL FINDBLOK (ROWS,PTR,NAMES(PTR,2),NAMES)
C     GO TO 1
C   END IF
C   ELSE
C     IF (TYPE(PTR,1) .EQ. 'S') THEN
C       IF (NAMES(PTR+1,1) .NE. NAMES(PTR,1)) THEN
C         CURVAL = VALUES(PTR)
C       ELSE
C         CURVAL = CURVAL * VALUES(PTR)
C       END IF
C     ELSE IF (TYPE(PTR,1) .EQ. 'P') THEN
C       IF (NAMES(PTR+1,1) .NE. NAMES(PTR,1)) THEN
C         CURVAL = 1.0-VALUES(PTR)
C       ELSE
C         CURVAL = CURVAL*(1.0-VALUES(PTR))

```

```

END IF
ELSE
TYPE *, ' ERROR IN SYSTEM FUNCTION LIST AT LINE ',PTR
C
STOP
C
END IF
IF((PTR .GT. 1) .AND. (NAMES(PTR-1,1) .EQ. NAMES(PTR,1)))THEN
PTR = PTR-1
GO TO 2
ELSE IF (PTR .GT. 1) THEN
IF (STPTR .GT. 1) THEN
IF (TYPE (PTR,1) .EQ. 'P') THEN
CURVAL = 1.0 - CURVAL
END IF
PTR = ISTACK(STPTR-1)
VALUES(PTR) = CURVAL
CURVAL = RSTACK(STPTR-1)
STPTR = STPTR-1
GO TO 2
END IF
ELSE
IF (TYPE(PTR,1) .EQ. 'P') THEN
EFFECTIVENESS = 1-CURVAL
ELSE
EFFECTIVENESS = CURVAL
END IF
GO TO 999
END IF
END IF
C
999 CONTINUE
RETURN
END
C
C

```

```
C .....  
C  
C   SUBROUTINE FINDBLOK (ROWS, PTR, PTRVALUE, NAMES)  
C  
C   CHARACTER*12 NAMES(50,2), PTRVALUE  
C   INTEGER*2 ROWS, PTR  
C  
C   PTR = 1  
C   DO WHILE ((PTRVALUE .NE. NAMES(PTR,1)).AND.(PTR .LE. ROWS))  
C     PTR = PTR + 1  
C   END DO  
C   IF ((PTRVALUE .NE. NAMES(PTR,1)).AND.(PTR .EQ. ROWS)) THEN  
C     STOP 'ERROR FROM FINDBLOK IN NAMES'  
C   END IF  
C   RETURN  
C   END  
C
```

```

C *****
C
C   SUBROUTINE GETMOT (ROWS)
C
C   CHARACTER*12 NAMES(50,2),DBLIS(100), RECNAME
C   CHARACTER*1 TYPE(50,2), DUMMY
C
C   INTEGER*2 LOCATE(50,2),ROWS,ISOURC, IMOTNS,IDBLIS,I,J,K
C   INTEGER*2 L,DBADDR(100),RECNUM, RECMOT,RECNT,MOTCOL
C   INTEGER*2 IDBASE, ERROR, DBSIZE
C
C   REAL VALUES(50), MOTNS(17), RECDEG(10,2), SYSMOT, LINTERP
C   REAL HIMOT, LOMOT, HIDEG, LODEG, MOTSPC(25,13), PRFSPC(25)
C   REAL MSUM, PSUM, ERRLIN, VARIANCE
C
C
C   COMMON /INOUT/ ISOURC,IMOTNS,IDBLIS,IDBASE
C   COMMON /SYSTEM/ NAMES,TYPE,LOCATE,VALUES
C   COMMON /SYSDAT/DBSIZE,DBLIS,DBADDR
C
C
C   ASSIGN 999 TO ERROR
C
C   READ IN MOTIONS OF LOCATIONS
C
C   READ (IMOTNS,100) (MOTNS(J),J=1,17)
100 FORMAT(17F7.3)
C
C   DO I=1,25
C   READ (IMOTNS, 105) (MOTSPC(I,J), J=1,13)
105 FORMAT(F10.4,12E14.7)
C   END DO
C
C   READ IN DATABASE LIST AND ADDRESSES
C
C   DO I=1,DBSIZE
C   READ (IDBLIS,110) DBLIS(I),DBADDR(I)
110 FORMAT(A12,I5)
C   END DO
C   5 FORMAT(A)
C
C   CALCULATE MOTION DEGRADATION
C
C   DO 2030 I=1,ROWS
C   IF (TYPE (I,2) .EQ. 'E') THEN
C
C   FIND ADDRESS OF ELEMENT
C
C   J=1
10 IF (NAMES(I,2) .EQ. DBLIS(J)) THEN
C   RECNUM = DBADDR(J)
C   GO TO 20
C   ELSE IF (J .EQ. DBROWS) THEN
C   GO TO ERROR

```

```

ELSE
  J=J+1
  GO TO 10
END IF

C          RECORD ADDRESS FOUND GET MOTN DEG.
20  READ (IDBASE,REC=RECNUM,FMT=1000) RECNAME,RECMT,(RECDEG(K,1),
  & RECDEG(K,2), K=1,10), ERRLIN
1000 FORMAT(A12,I2,10(F5.3,F7.2),F7.3)

C
C  NOW HAVE EQUIP MOTIONS FUNCTION, FILL VALUES WITH MOTIONS
C
C  FIND CORRECT COLUMN OF MOTIONS
C
IF (RECMT .EQ. 1) THEN
  MOTCOL = 3
ELSE IF (RECMT .LT. 5) THEN
  MOTCOL = 1 + (3*LOCATE(1,1)) + RECMT
ELSE
  MOTCOL = 3*(LOCATE(1,1)-1) + RECMT-2
END IF

C          DO MOTION CALCULATIONS
IF (RECMT .LT. 5) THEN
  SYSMOT = MOTNS(MOTCOL)
  RECNT = 1
40  IF (RECDEG(RECNT,2) .GT. SYSMOT) THEN
    IF (RECNT .EQ. 1) THEN
      LODEG = 1.0
      LOMOT = 0.0
      HIDEG = RECDEG(RECNT,1)
      HIMOT = RECDEG(RECNT,2)
    ELSE
      LODEG = RECDEG(RECNT-1,1)
      LOMOT = RECDEG(RECNT-1,2)
      HIDEG = RECDEG(RECNT,1)
      HIMOT = RECDEG(RECNT,2)
    ENDIF
    VALUES(I) = LINTERP(SYSMOT,LOMOT,LODEG,HIMOT,HIDEG)
  ELSE IF (RECNT .EQ. 10) THEN
    VALUES(I) = RECDEG(RECNT,1)
  ELSE
    RECNT = RECNT + 1
    GO TO 40
  ENDIF

C          DO SPECTRUM ANAL
C
ELSE
C
DO J = 1,25
  RECNT = 1
  DO WHILE (RECDEG(RECNT,2) .LT. MOTSPC(J,1))
    RECNT = RECNT + 1
  END DO
C

```

```

      IF (RECNT .EQ. 1) THEN
        LDEG = 0.0
        LOMOT = 0.0
        HIDEG = RECDEG(1,1)
        HIMOT = RECDEG(1,2)
      ELSE
        LDEG = RECDEG(RECNT-1,1)
        LOMOT = RECDEG(RECNT-1,2)
        HIDEG = RECDEG(RECNT,1)
        HIMOT = RECDEG(RECNT,2)
      END IF
      XFER = LINTERP (MOTSPC(J,1),LOMOT,LDEG,HIMOT,HIDEG)
      PRFSPC(J) = XFER * MOTSPC(J,MOTCOL)
    END DO
  C
    IF (PRFSPC(1) .LT. 0.0) THEN
      PRFSPC(1) = 0.0
    END IF
    PSUM = 0.0
    DO 2060 J=2,25
      IF (PRFSPC(J) .LT. 0.0) THEN
        PRFSPC(J) = 0.0
      END IF
      DIFF = MOTSPC(J,1)-MOTSPC(J-1,1)
      PSUM = PSUM + (PRFSPC(J-1)+PRFSPC(J))*DIFF
2060  CONTINUE
      VARIANCE = PSUM/2.0
      VALUES(1) = EFFEC(SQRT(VARIANCE), ERRLLIM)
    END IF
  END IF
  C
2030 CONTINUE
  C
    GO TO 9999
    999 STOP ' DATA ERROR IN SUBROUTINE GETMOT'
    9999 CONTINUE
    RETURN
  END
  C

```

```

C *****
C
C   SUBROUTINE OUTPUT(ROWS,EFFECTIVENESS)
C
C   CHARACTER*12 NAMES(50,2)
C   CHARACTER*1 TYPE(50,2)
C   INTEGER*2 LOCATE(50,2), ROWS,I,J,LEAST
C   REAL VALUES(50),EFFECTIVENESS
C
C   COMMON /SYSTEM/ NAMES, TYPE, LOCATE, VALUES
C
C   WRITE (*,120) EFFECTIVENESS
C   WRITE (7,120) EFFECTIVENESS
120 FORMAT(///,5X,'THE EFFECTIVENESS RELATIVE TO THIS FEASIBLE ',/
& ,5X,'DESIGN CALM WATER PERFORMANCE IS',//,10X,F4.2)
C
C   LEAST = 1
C
C   DO I=1,ROWS
C     IF ((TYPE(I,2) .EQ. 'E') .AND. (VALUES(I) .LT. VALUES(LEAST)))
& THEN
C       LEAST = I
C     END IF
C   END DO
C
C   WRITE (*,130) NAMES(LEAST,2),VALUES(LEAST)
C   WRITE (7,130) NAMES(LEAST,2),VALUES(LEAST)
130 FORMAT(/,5X,'EQUIPMENT/SUBSYSTEM WITH WORST PERFORMANCE',
& /,10X,'NAME',27X,A12,/10X,'RELATIVE EFFECTIVENESS',5X,F4.2)
C
C   WRITE (*,50)
C   WRITE (7,50)
50 FORMAT (/,'          SYSTEM LIST',/,10X,'BLOCK',9X,'ELEMENT',
& 5X,'SER/PAR',2X,'BLOCK/ELEMENT',2X,'EFFECTIVENESS')
C   DO I = 1,ROWS
C     WRITE(*,100)NAMES(I,1),NAMES(I,2),TYPE(I,1),TYPE(I,2),VALUES(I)
C     WRITE(7,100)NAMES(I,1),NAMES(I,2),TYPE(I,1),TYPE(I,2),VALUES(I)
100 FORMAT(10X,A12,2X,A12,3X,A1,11X,A1,8X,F4.2)
C   END DO
C   RETURN
C   END
C

```

```

C *****
C
C   REAL FUNCTION LINTERP (TGTX,LOX,LOXY,HIX,HIXY)
C
C   REAL TGTX,LOX,LOXY,HIX,HIXY
C
C   LINTERP = LOXY+((HIXY-LOXY)/(HIX-LOX))*(TGTX-LOX)
C
C   RETURN
C   END
C
C
C *****
C
C   REAL FUNCTION EFFEC(SIGMA,LIMIT)
C
C   REAL CONST, SIGMA, INCREM, LIMIT, DELTA, X
C
C   CONST = SQRT(2*3.14159)
C   INCREM = LIMIT/50.0
C   X = -LIMIT
C   EFFEC = EXP(-(X**2)/(2*(SIGMA**2))) / (CONST*SIGMA)
C
C   DO I=1,99
C     X = X + INCREM
C     EFFEC=EFFEC + 2*EXP(-(X**2)/(2*(SIGMA**2))) / (CONST*SIGMA)
C   END DO
C
C   X = LIMIT
C   EFFEC = EFFEC + EXP(-(X**2)/(2*(SIGMA**2))) / (CONST*SIGMA)
C   EFFEC = (EFFEC/2.0) * INCREM
C   RETURN
C   END

```

END

FILMED

9-84

DTIC