

MICROCOPY RESOLUTION TEST CHART
NATIONAL BUREAU OF STANDARDS - 1963 - A

12

AD-A145 076

**THE DEVELOPMENT OF A DIODE LASER
DOPPLER VELOCIMETER FOR BOUNDARY
LAYER MEASUREMENTS UNDER ICE**

A Feasibility Investigation

J. C. Schedvin and H.-T. Liu

**Flow Industries, Inc.
Research and Technology
21414-68th Avenue South
Kent, Washington 98032**

May 1984

**Final Report for Period 26 September 1983
through 26 March 1984**

**APPROVED FOR PUBLIC RELEASE
DISTRIBUTION UNLIMITED**

Prepared for

**OFFICE OF NAVAL RESEARCH
800 North Quincy Street
Arlington, Virginia 22217**

**DTIC
ELECTE
SEP 5 1984
S D
D**

DTIC FILE COPY

84 08 31 022

Unclassified

SECURITY CLASSIFICATION OF THIS PAGE (When Data Entered)

REPORT DOCUMENTATION PAGE		READ INSTRUCTIONS BEFORE COMPLETING FORM	
1. REPORT NUMBER	2. GOVT ACCESSION NO. <i>A145-076</i>	3. RECIPIENT'S CATALOG NUMBER	
4. TITLE (and Subtitle) The Development of a Diode Laser Doppler Velocimeter for Boundary Layer Measurements Under Ice: A Feasibility Investigation		5. TYPE OF REPORT & PERIOD COVERED Final Report 26 Sept 1983 - 25 March 1984	
7. AUTHOR(s) J. S. Schedvin and H.-T. Liu		6. PERFORMING ORG. REPORT NUMBER Flow Report No. 290	
9. PERFORMING ORGANIZATION NAME AND ADDRESS Flow Industries, Inc. 21414 - 68th Avenue South Kent, Washington 98032		8. CONTRACT OR GRANT NUMBER(s) N00014-83-C-0764	
11. CONTROLLING OFFICE NAME AND ADDRESS Office of Naval Research 800 North Quincy Street Arlington, Virginia 22217 <i>Robert F. Abrecht</i>		10. PROGRAM ELEMENT, PROJECT, TASK AREA & WORK UNIT NUMBERS	
14. MONITORING AGENCY NAME & ADDRESS (if different from Controlling Office)		12. REPORT DATE May 1984	
		13. NUMBER OF PAGES 54	
		15. SECURITY CLASS. (of this report) Unclassified	
		15a. DECLASSIFICATION/DOWNGRADING SCHEDULE	
16. DISTRIBUTION STATEMENT (of this Report) Approved for public release; Distribution unlimited.			
17. DISTRIBUTION STATEMENT (of the abstract entered in Block 20, if different from Report) Approved for public release; Distribution unlimited.			
18. SUPPLEMENTARY NOTES			
19. KEY WORDS (Continue on reverse side if necessary and identify by block number)			
coherence length laser Doppler velocimeter oceanic boundary layer diode laser marginal ice zones Doppler burst spatial resolution Doppler frequency spectral bandwidth frequency response turbulent flux			
20. ABSTRACT (Continue on reverse side if necessary and identify by block number)			
Measurements of the turbulent fluxes of momentum, heat, and salinity in the oceanic boundary layer are very difficult to obtain, as both a stable platform and high-resolution instrumentation are required. The Arctic Ocean is one region in which high-quality boundary layer stress measurements have been			

(cc) obtained by using drifting ice floes as stable platforms for instrument deployment. The overall objective of the present investigation, ~~was~~ ^{was} DOD-sponsored SBIR Phase I project, has been ~~to~~ ^{to} develop a boundary layer instrumentation system capable of measuring turbulent fluxes in the marginal ice zone environment. In particular, this investigation focuses on a feasibility study toward ~~the~~ ^{the} development of a diode laser Doppler velocimeter (DLDV) to be used as the velocity sensor for a high-resolution velocity/temperature/conductivity cluster, with a spatial resolution of 1 to 2 cm. Essential findings are presented and discussed to assess the feasibility of the proposed development. The Phase I findings show very promising results for the DLDV in laboratory environments. Measurements in a pipe flow facility have demonstrated very distinctive Doppler burst signals, with more than adequate signal-to-noise ratio, even in clean tap water passed through a 10 μ m filter. Excellent burst density was observed when a small quantity of Puget Sound water was added to the tap water. For all practical purposes, the performance of the DLDV is at least as good as that of a well-established LDV system using a helium-neon laser as the light source. ~~Based on these~~ encouraging findings, a Phase II proposal has been submitted for further research and development toward the construction of the DLDV-temperature/conductivity clusters. Emphasis will be made on the field adaptability of the DLDV, the integration of a microprocessor-controlled high-resolution cluster, and participation in the 1984 Marginal Ice Zone Experiment and the 1985 Arctic Internal Wave Experiment.

Accession For	
NTIS GRA&I	<input checked="" type="checkbox"/>
DTIC TAB	<input type="checkbox"/>
Unannounced	<input type="checkbox"/>
Justification	
By	
Distribution/	
Availability Codes	
Dist	Avail and/or Special
A/1	

DTIC
COPY
RESPECTED
2

FOREWORD

This DOD SBIR Phase I project is sponsored by the Office of Naval Research (ONR), Department of the Navy, under Contract No. N00014-83-C-0764. Mr. Robert F. Obrochta is the Technical Monitor. Phase I consists of a total of three (3) tasks to develop and test a boundary layer instrumentation system capable of measuring turbulent fluxes in the marginal ice zone (MIZ) environment:

- Task 1. Development of moderate-resolution oceanographic instrumentation clusters
- Task 2. Feasibility study of the use of diode lasers in a compact Doppler velocimeter system
- Task 3. Development of a modular data acquisition interface system and deployment frames for the clusters

The work performed under Task 1 is documented elsewhere (McPhee and Schedvin, 1984a; 1984b). This report documents the research and development activities conducted in Task 2. Part of Task 3 has been completed, and the system will be tested in Phase II. Documentation of Task 3 will be prepared at a later date.

The results of Phase I have demonstrated the feasibility of developing a diode laser Doppler velocimeter (DLDV) for oceanic boundary layer measurements. A Phase II proposal has been submitted to ONR, and funding has been approved for further research and development leading to the assembly of prototype field DLDVs to be deployed and tested, together with the moderate-resolution oceanographic sensor clusters, during the 1984 Marginal Ice Zone Experiment (MIZEX 84). Revision and improvement of the DLDV, if required, will then be incorporated into the final design according to the MIZEX findings. Finally, a prototype high-resolution oceanographic sensor cluster, including three-component DLDV and miniature conductivity and temperature sensors, will be developed. Both the high- and moderate-resolution clusters will be deployed in the Arctic Internal Wave Experiment in 1985 (AIWEX 85).

ACKNOWLEDGEMENT

This report is dedicated to Dr. John Carl Schedvin (1949-1984), the senior author who suffered a heart attack and passed away soon after completing this Phase I investigation. Dr. Schedvin was instrumental in developing the diode laser Doppler velocimeter and in demonstrating its feasibility as a water velocimeter. The proposed development was originated by Dr. J. Thomas McMurray. A special thanks is extended to Professor Edward J. Shaughnessy of Duke University, who is one of the pioneers initiating the idea of replacing gas lasers with diode lasers for laser velocimetry. Throughout the course of the Phase I work, he has provided much invaluable advice, leading to the successful demonstration of the proposed development. His willingness in sharing his technical expertise with us and providing hardware support to expedite the Phase I investigation is especially appreciated.

Table of Contents

	Page
Foreword	1
List of Figures and Tables	4
1. Introduction	5
1.1 Background	5
1.2 Proposed DLDV Oceanographic Instrumentation System	8
2. Literature Review	11
2.1 LDV Theory and Techniques	11
2.2 Laser Diodes	18
3. Laboratory Equipment and Facility	25
3.1 Vertical Pipe Test Facility	25
3.2 Macrodyne Counter Processor	25
3.3 Nicolet Digital Oscilloscope	27
4. Phase I Results	28
4.1 Laser Diode Characteristics	28
4.2 DLDV Optical Arrangement and Photodetector	34
4.3 Laboratory Testing	37
4.4 DLDV Prototype Design	46
5. Conclusion and Recommendations	50
References	53

List of Figures and Tables

	Page
Figure 1. LDV configurations for heterodyne detection.	12
Figure 2. Fringe model.	14
Figure 3. Doppler signals representative of LDV measurements.	16
Figure 4. Schematic of the double heterostructure laser.	19
Figure 5. Schematic view of the laser on its heatsink.	21
Figure 6. Output power versus forward current.	22
Figure 7. Output power dependence on emission spectra.	24
Figure 8. Vertical pipe test facility.	26
Figure 9. Light intensity distribution for HL7801G laser diode.	33
Figure 10. Diode laser Doppler velocimeter test configuration.	36
Figure 11. Fiber optic rod light collection with and without shroud.	41
Figure 12. Large Doppler burst with helium-neon laser using lenses to focus scattered light on photodiode.	43
Figure 13. Typical Doppler burst with SCW-21 laser diode and fiber optic rod pickup.	44
Figure 14. Prototype DLDV design for field test.	49
Figure 15. Underwater DLDV laser diode optic module.	49
Table 1. Extinction coefficients in seawater	29
Table 2. Laser diode characteristics	29

1. INTRODUCTION

Under a DOD SBIR Phase I contract sponsored by the Office of Naval Research (ONR), Flow Industries has conducted the initial feasibility investigation to develop a boundary layer instrumentation system capable of measuring turbulent fluxes in the marginal ice zone (MIZ) environment. The central feature of this system will be instrumentation clusters that provide single-point measurements of the turbulent fluxes of momentum, heat, and salinity. The development efforts included: (1) the design of a modular current meter/temperature/conductivity instrument cluster for single-point turbulent flux measurements; (2) the development of a high-resolution (about 1 to 2 cm in spatial resolution), diode laser Doppler velocimeter (DLDV) capable of resolving small scales of the turbulent fluxes; and (3) the integration of the instrumentation cluster, a data acquisition interface, and instrument support frames into a complete boundary layer measurement system.

This report documents the research and development activities for the second item described above, as a part of the integrated Phase I efforts. The findings from this investigation are examined and the feasibility of successful development of the DLDV is assessed. In Section 2, we present a brief review of the theory of velocity sensing and the general characteristics of laser diodes pertinent to the development of the DLDV. The experimental methods and the laboratory facility in which the Phase I work was conducted are described in Section 3. In Section 4, we present and discuss the essential findings leading to the successful demonstration of the proposed development. In Section 5, we summarize the highlights of our findings and present recommendations for Phase II research and development.

In the remainder of this section, we first present background information on the problem of obtaining accurate measurements of turbulent fluxes of momentum, heat, and salinity in the oceanic boundary layer, particularly in the marginal ice zone. Then we describe our proposed instrumentation system and the DLDV concept, which will allow high-resolution measurement of turbulent fluxes.

1.1 Background

One of the problems of central importance to boundary layer research is the measurement of the turbulent fluxes of momentum, heat, and salinity. Deter-

mination of these quantities requires the measurement of second-moment turbulent transport terms, i.e., $u'w'$, $v'w'$, $w'T'$, $w'S'$ where u , v and w are the three velocity components, T is the temperature, and S is the salinity, and where the prime (') terms refer to the fluctuating components. High-quality flux measurements are difficult to obtain due to contamination by sensor motion and the small scales of turbulent fluctuations.

Measurements of boundary layer processes in the MIZ are of great interest to the Navy and form one facet of the Marginal Ice Zone Experiment (MIZEX) (Johannessen et al. 1983). Drifting ice floes provide an excellent, stable platform for the deployment of turbulence instrumentation, as has been demonstrated by boundary layer stress measurements (McPhee and Smith, 1976). While these measurements were made in the Arctic ice pack, a similar approach is promising for MIZ measurements. The MIZ presents a more difficult environment due to variable density and current structures, greater mobility of the ice cover, surface buoyancy fluxes from rapidly melting ice, and the influence of surface gravity waves. But along with these difficulties, the presence of strong surface buoyancy fluxes also provides a unique opportunity to make high-quality measurements of turbulent fluxes of heat and salinity in an oceanic boundary layer. These features indicate that boundary layer measurements in the MIZ must be made simultaneously at a number of levels and that boundary layer measurement system must be flexible so that it may be configured to provide optimal measurements under a variety of conditions. Another aspect of the MIZ environment is the influence of strong stability due to melting. These considerations indicate a need for high-resolution sensors (to centimeter scale) to completely resolve the turbulent fluxes.

The understanding of the turbulence in the oceanic boundary layer (OBL) under drifting pack ice has increased dramatically over the past decade as the result of direct measurements of mean velocity and Reynolds stress (McPhee and Smith, 1976) and from relating models of turbulent stress to observed ice drift. The AIDJEX Reynolds stress measurements also established the feasibility of using drifting ice floes as a stable platform for difficult turbulence measurements in the upper ocean. These detailed measurements of stress in the OBL have provided an important data set for comparison with analytic and numerical boundary layer theories and have shown clearly the correspondence between the planetary boundary layers of the ocean and the atmosphere.

Comprehensive data sets are very important for the development of our understanding of boundary layer processes. It has primarily been through detailed measurements of the turbulent flux profiles that progress has been made in the modeling of the atmospheric boundary layer (Businger, 1975; Kaimal et al., 1976).

In analytic or numerical models of the OBL, the second-moment turbulence quantities must be approximated in some manner. Generally this involves expressing these quantities as functions of the mean profiles of velocity, temperature, and salinity. Mellor and Durbin (1975) have applied such "closure" schemes to the modeling of the open ocean mixed layer, and Simpson and Dickey (1981) have applied a similar model to numerical experiments on mixed layer dynamics. In a related approach, McPhee (1981, 1983) has extended the application of rotational boundary layer theory from the atmosphere, where it has been used successfully to explain boundary layer dynamics, to the ice-covered OBL. All of these modeling efforts have in common the need for boundary layer measurements that can be used to verify which concepts or approximations have merit and to aid in choosing between alternative parameterizations.

In the MIZ, many features of general importance to OBL modeling are present: a rotational stress boundary layer under the drifting ice floes, surface buoyancy fluxes due to rapidly melting ice, and significant stratification at the base of the surface layer. The unique platform provided by drifting ice floes and the special conditions encountered in the MIZ provide an important opportunity to obtain a data set of general utility for the investigation of OBL dynamics. This data set would include profiles of velocity, temperature, and salinity and measurements of the fluxes of momentum, heat, and salinity through the entire boundary layer.

While there have been significant advances in understanding the physics of the OBL, there has not been a comparable advance in the instrumentation available for OBL measurements. Acoustic and electromagnetic current meters that have been developed for oceanographic work have spatial resolutions that are comparable to those of the propeller meters used by McPhee and Smith, but they are considerably larger and more expensive. Both of their size and cost are significant deterrents to the use of arrays of these advanced sensors in boundary layer measurements. The acoustic and electromagnetic sensors are

A145076

capable of resolving most of the turbulent flux scales; however, their response will be inadequate near the ice interface and in regions of strong stratification, both of which may frequently occur in the MIZ. In addition to high-resolution velocity sensors, a further requirement for scalar flux studies is that simultaneous measurements of vertical and horizontal velocity components, temperature and salinity must be made at the same spatial location.

1.2 Proposed DLDV Oceanographic Instrumentation System

The present investigations were directed toward developing a state-of-the-art OBL measurement system. We proposed to develop a modular system of instrument clusters using state-of-the-art sensors wherever possible and developing new sensors as needed. A moderate-spatial-resolution cluster consists of small, partially ducted current meters that measure three orthogonal velocity components. This current meter configuration is being used by McPhee in MIZEX 83 and is essentially the same as the AIDJEX sensors used by McPhee and Smith (1976). For the proposed instrument cluster, a fast-response temperature and conductivity sensor will be integrated with the propeller triplets to provide single-point measurements of turbulent fluxes. Spatial resolution will be limited to about 10 cm by the response of the current meters and collocation of the sensors. A high-resolution cluster will use a DLDV instead of the propeller meters. This will allow resolution of the turbulent fluxes to scales of about 1 to 2 cm. In this case, the resolution will primarily be limited by practical considerations of sensor placement and the necessity to measure the velocity and scalar components in the same fluid volume. This decrease in sampling volume will allow complete resolution of the turbulent fluxes. These instrument clusters will be used in a modular boundary layer array measurement system, which will be the final product of the development effort.

Development of the DLDV will produce a significant advance in instrumentation for OBL measurements. In the past 15 years, the laser Doppler velocimeter (LDV) has been developed and applied to the measurement of fluid velocities. The LDV method is based on the measurement of the Doppler shift of light scattered from small particles in the flow. The motion of the particles causes the frequency of the scattered light to be shifted by an amount proportional to a component of the particle velocity. The LDV requires no calibration, its

response is linear, and it measures the fluid velocity remotely, which makes it possible to minimize disturbance of the flow by the sensor. The LDV technique does have directional ambiguity, since the measured Doppler frequency is always positive regardless of the flow direction. Using a standard technique called frequency shifting, the magnitude and direction of the velocity field can be determined.

The LDV is used routinely in a wide variety of laboratory flows to measure turbulence (e.g., Liu and Lin, 1984), but has seen little use for turbulence measurements in geophysical flows. McMurray and Shaughnessy (1982) pioneered the development of submersible LDV systems for turbulence measurements in oceanic flows. Their results indicate that a system can be deployed in the ocean for long periods of time without any loss of optical alignment. In addition, their probe has a spatial resolution of 2.5 mm, allowing measurement of turbulent fluctuations through the inertial subrange down to the beginning of the viscous dissipation range. Their results clearly show that the LDV technique can be applied to measure small-scale velocity fluctuations in geophysical flows with excellent results.

One of the difficult problems in using conventional LDV systems in geophysical flows is the need to house a gas laser, optics, and photodetectors in a watertight housing. While McMurray and Shaughnessy have developed such a device and successfully tested it in a high Reynolds tidal channel flow, the submerged system is bulky and requires several sets of power and signal cables for the electronics and laser. Recent advances in fiber optics have been used in attempts to alleviate this problem by placing the gas laser and electronics in a container on the surface and using fiber optic cables to transmit laser light down to the sensor head, which is composed of optics only. The scattered light signal is collected by the receiving optics and transmitted to the photo-detector next to the laser through second fiber optic cable. This technique has been successfully demonstrated in several laboratory studies (Knuhtsen et al., 1982; Colella and Neti, 1982; Ohba and Matsuno, 1982) and is a viable alternative for measuring flows in the laboratory and in industrial environments. For remote field environments, the system is not practical; it is bulky and expensive and requires large power supplies. If multipoint measurements are needed, then several gas lasers are required. The use of gas

lasers in the field is a severe limitation to using LDV systems for geophysical measurements.

The alternative to using a gas laser is to use a semiconducting GaAlAs diode laser. These solid-state devices are very efficient emitters of coherent infrared light at wavelengths ranging from 760 to 830 nm. Shaughnessy and Zu'Bi (1978) first demonstrated that diode lasers possess sufficient coherence length and that their output beam can be collimated to allow their usage as the coherent light source in an LDV system. The recent increase in the coherence length of GaAlAs diode lasers from less than 1 mm to 50 mm makes them very attractive for field instruments. This increase in coherence length eases the optical design restrictions and makes the resulting system less susceptible to loss of coherence due to misalignment. A second advantage of using a diode laser is that it requires only a 200 mA current at 5 volts to produce 10 mW of power. The diode laser itself is only 10 mm in diameter and 20 mm in length so it can be directly incorporated into the submerged sensor, thereby eliminating the need for fiber optic cables.

In summary, the recent advances in semiconductor diode laser technology allow a miniature DLDV system to be designed for measuring the complete velocity field in an oceanic boundary layer flow. The system can be designed to have low power requirements, be small in size, and have modular packaging. An array of DLDV sensors can be developed to permit multipoint measurements of the entire spectrum of fluid motions in an OBL. Such a system represents a major advance in the state of the art of oceanographic sensors.

2. LITERATURE REVIEW

Although the laser Doppler velocimeter (LDV) is currently considered to be a state-of-the-art technique for many applications, its basic theory has been well established (Durst et al., 1976). To perfect the LDV technique, current research and development efforts are exploring the use of innovative design concepts, electro-optical components, and software and hardware for signal processing. In this section, we review briefly the basic theory and current status of the LDV technique pertinent to our development.

2.1 LDV Theory and Techniques

Optical Arrangement

Optical heterodyne detection is most frequently adopted for LDV measurements. It detects the Doppler shift in the frequency of light scattered from moving particles as the difference frequency between two coherent laser beams. Detection is made with a photodetector by mixing the two beams at the surface of the detector. Figure 1 shows the three optical configurations commonly used for heterodyne detection:

- (1) The reference beam system mixes the scattered light from one incident beam and the light from the reference beam.
- (2) The dual-scattered-beam system mixes the scattered light from two directions.
- (3) The dual beam system mixes the scattered light from two incident beams.

Among these three configurations, the dual-beam system is the most popular. For our proposed DLDV sensor, we will use this configuration because it is flexible and easy to align. In addition, a "fringe model," a conceptually simple model that offers correct frequency information, may be used to describe the system conveniently. Therefore, we will concentrate on the dual-beam system, although much of the information given below is also applicable to the other two systems.

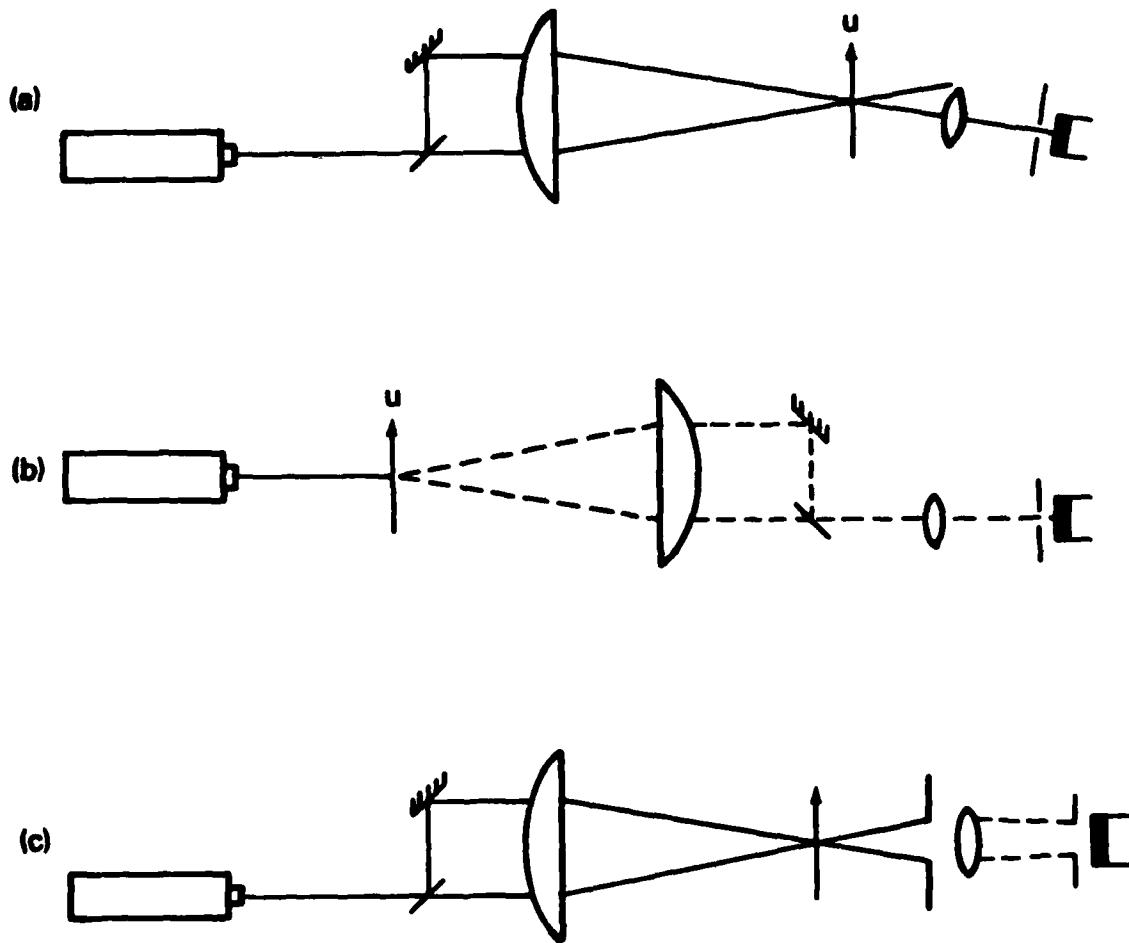

Figure 1. LDV configurations for heterodyne detection.

Relation of Frequency and Velocity

For the dual-beam system, the Doppler frequency, f_D , of the light scattered from a particle moving at a velocity \vec{u} can be given as follows:

$$f_D = \frac{\vec{u}}{\lambda} \cdot (\vec{k} - \vec{k}') \quad (1)$$

where \vec{k} and \vec{k}' are the unit vectors of the two incident beams and λ is their wavelength. Then, since $|\vec{k} - \vec{k}'| = 2 \sin \phi$

$$f_D = \frac{2 u_x \sin \phi}{\lambda} \quad (2)$$

where ϕ is the half angle between the two beams and u_x is the component perpendicular to the bisector of the two illuminating beams and in the same plane. Equation (2) represents one of the most important physical relationships in LDVs and can be shown to apply to all the optical configurations in Figure 1. This equation has been accurately verified using rotating disks (Thermo-Systems, Inc., 1979).

Fringe Model

The fringe model is developed based on the observed alternating dark-bright pattern resulting from the interference of two crossing laser beams as shown in Figure 2. From the geometry of the laser beams, we find that the fringe spacing may be expressed as

$$d_f = \frac{\lambda}{2 \sin \phi} \quad (3)$$

Therefore, Equation (2) may be given in an alternate form relating the fringe spacing to the particle velocity:

$$u_x = d_f f_D \quad (4)$$

Note that the fringe model is not entirely appropriate when applied to the theoretical analysis of Doppler signals, such as the signal-to-noise ratio (SNR) or visibility (Thermo-Systems, Inc., 1979).

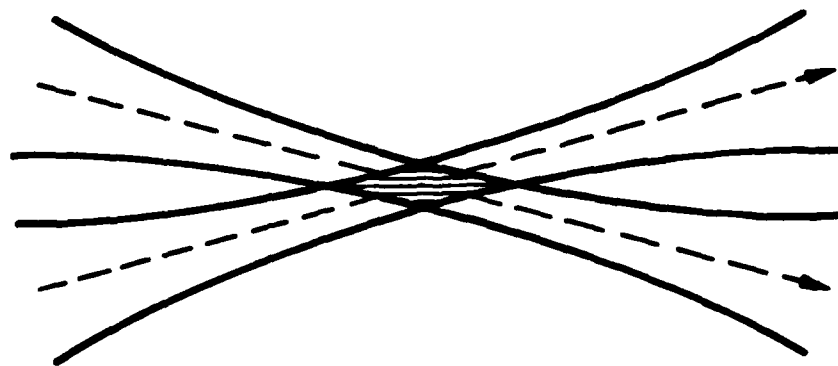
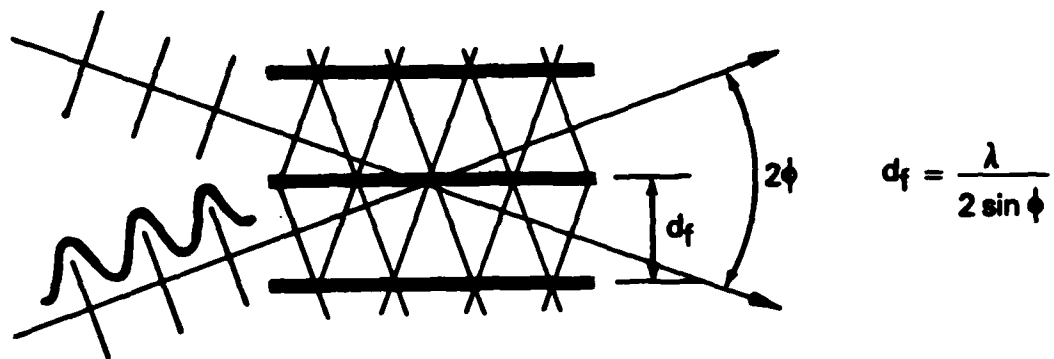

Figure 2. Fringe model.

Measuring Volume

At the intersection of the two transmitting laser beams in the dual-beam system, a focal volume is formed. The focal volume is an ellipsoid with edges that are defined as the point where the amplitude of the Doppler signal is $1/e^2$ of its centerline value. Depending on the configuration of the collecting optics, the measuring volume may be only a fraction of the focal volume. For example, the measuring volume may reduce significantly from the focal volume by off-axis collection, thus avoiding the long focal length (see Figure 2) due to the small angle of the transmitting beams.

Shape and Strength of Doppler Signal

The shape of the Doppler signal depends on the size of the scattering particles and their paths relative to the center of the focal volume. Figure 3 shows three typical Doppler signals obtained using an LDV. The ideal Doppler signal corresponds to that generated by a small particle (a), where the diameter of a is less than d_f , passing through the center region of the focal volume. The root-mean-square (rms) amplitude of the signal is large compared to its low-frequency component or "pedestal". The ratio of the above two quantities is defined as the visibility. For a small particle (b) passing through the focal volume near the side edges, the Doppler signal contains only a few cycles. For a large particle (c), the signal has a small rms amplitude but a large pedestal and, thus, low visibility.

The strength of the Doppler signal depends on the laser power, the particle size, and the scattering or collecting angle. For the same laser power and particle size (of the order of the fringe spacing), forward scattering has the strongest signal, whereas backscattering is about 2 to 3 orders of magnitude lower in signal strength. Off-axis backscattering generally has the weakest signal of all. Another method to increase the strength of the scattered light is to reduce the size of the focal volume, thus increasing the peak intensity. This may be achieved by expanding the transmitting beams through a negative-positive lens combination (Thermo-Systems, Inc., 1979). Reduction by a factor of 2 in the focal beam diameter leads to a factor of 4 increase in peak intensity, which improves the signal level significantly for a given size laser (Stevenson, 1979).

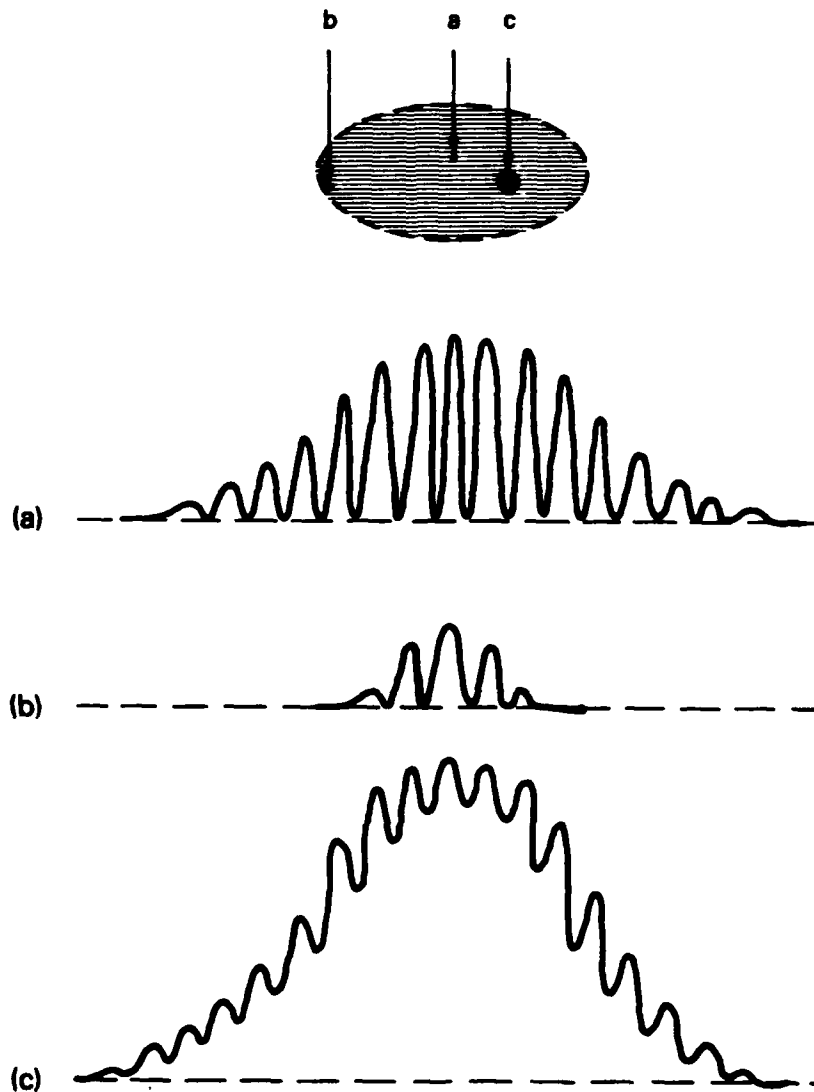

Figure 3. Doppler signals representative of LDV measurements.

Signal Processing

The collecting optics transmit the Doppler signals to the photodetector. The voltage output from the photodetector contains the Doppler frequency that varies with the velocity of the scattering particles. To extract the Doppler frequency information from the photodetector signals, a set of electronics is required. Part of the electronics may include a bandpass filter to remove the high-frequency noise and the low-frequency pedestal and an amplifier to boost the signal level.

The major part of the electronics is a signal processor. Primarily, there are three types of processors. The photon correlator, which is equivalent to an analog correlator used in autocorrelation mode, is suitable for low photon signals (low light flux). For low-speed flow, a fast Fourier transform (FFT) may be used alternatively. This type of processor can only provide the mean value of the particle velocity and, therefore, is not suitable for measurements of turbulence, as in the present application.

For high photon density, both tracker- and counter-type processors are often used. The tracker-type processor uses a bandpass filter and frequency discriminator to "track" the frequency changes in the photodetector output. The use of the bandpass filter permits a tracker to operate on Doppler signals that have a relatively poor SNR. The output of most trackers is an analog voltage proportional to the input frequency. It is perhaps most frequently used on high burst density signals (high particle density) and in flows of modest turbulence intensity. If the Doppler frequency changes too abruptly in a highly turbulent flow, a high percentage of dropout in the output may result due to the inability of this type of processor to track the rapid bursts.

The counter-type processor will operate at any burst density or turbulence intensity as long as the SNR is adequate. It is most often adopted in highly turbulent flows because it overcomes the limitations of the tracker-type processors. In essence, the counter-type processor measures the time, t_1 , for n_1 cycles of the Doppler signal in terms of the number of zero crossings. This time is often compared to that for a different number of zero crossings as a means of validation. The Doppler frequency is therefore $f_D = n_1/t_1$.

2.2 Laser Diodes

The DLDV is an LDV with its gas laser replaced by a laser diode or semiconductor laser as the coherent light source. A laser diode is a coherent light-emitting semiconductor diode that is undergoing stimulated emission. There are a large number of laser diodes available, but only a few have characteristics that are suitable for use in an underwater LDV. In this section, a brief description of the general characteristics of laser diodes is given. The relevant criteria of laser diodes for DLDV applications will be discussed in Section 4.1.

Here, we consider only the continuous wave (CW) rather than the pulsed diode laser. The advantages of the laser diode over the gas laser as the light source of the LDV are many fold. The following are the two most important advantages for use as an underwater field instrument. First, the much smaller diode laser in size and weight is particularly attractive in terms of portability and avoiding flow disturbances. Second, the laser diode is very efficient and consumes a small amount of electrical power, which can be adequately supplied from dc batteries if necessary.

General Description

A semiconductor laser consists of a P-N junction where the radiative recombination of electrons and holes gives stimulated radiation at high injection current levels. An oscillator can be achieved if the cavity is designed to give a positive feedback of the radiation.

The GaAlAs laser diodes are made by heteroepitaxy on a GaAs substrate. To increase the efficiency of the laser, the recombination zone (active layer $\text{Ga}_{1-x}\text{Al}_x\text{As}$ with typical thickness of $0.2 \mu\text{m}$) has been made between two cladding layers $\text{Ga}_{1-y}\text{Al}_y\text{As}$ ($y > x$) with dopant elements to give n and p type layers. Here, x and y are the percentage of Al used in the layers. This configuration forms the so-called double heterostructure.

The x part of aluminum in the active layer controls the wavelength of the laser: a value of $x = 6\%$ is used for an 840 nm wavelength laser. A higher percentage of aluminum y in the cladding layers has two main effects. First, it increases the band gap of the layer to provide a potential barrier, which confines electrons and holes to the active layer. Second, it induces a decrease in refractive index, which leads to a confinement of the optical power in the active layer (see Figure 4).

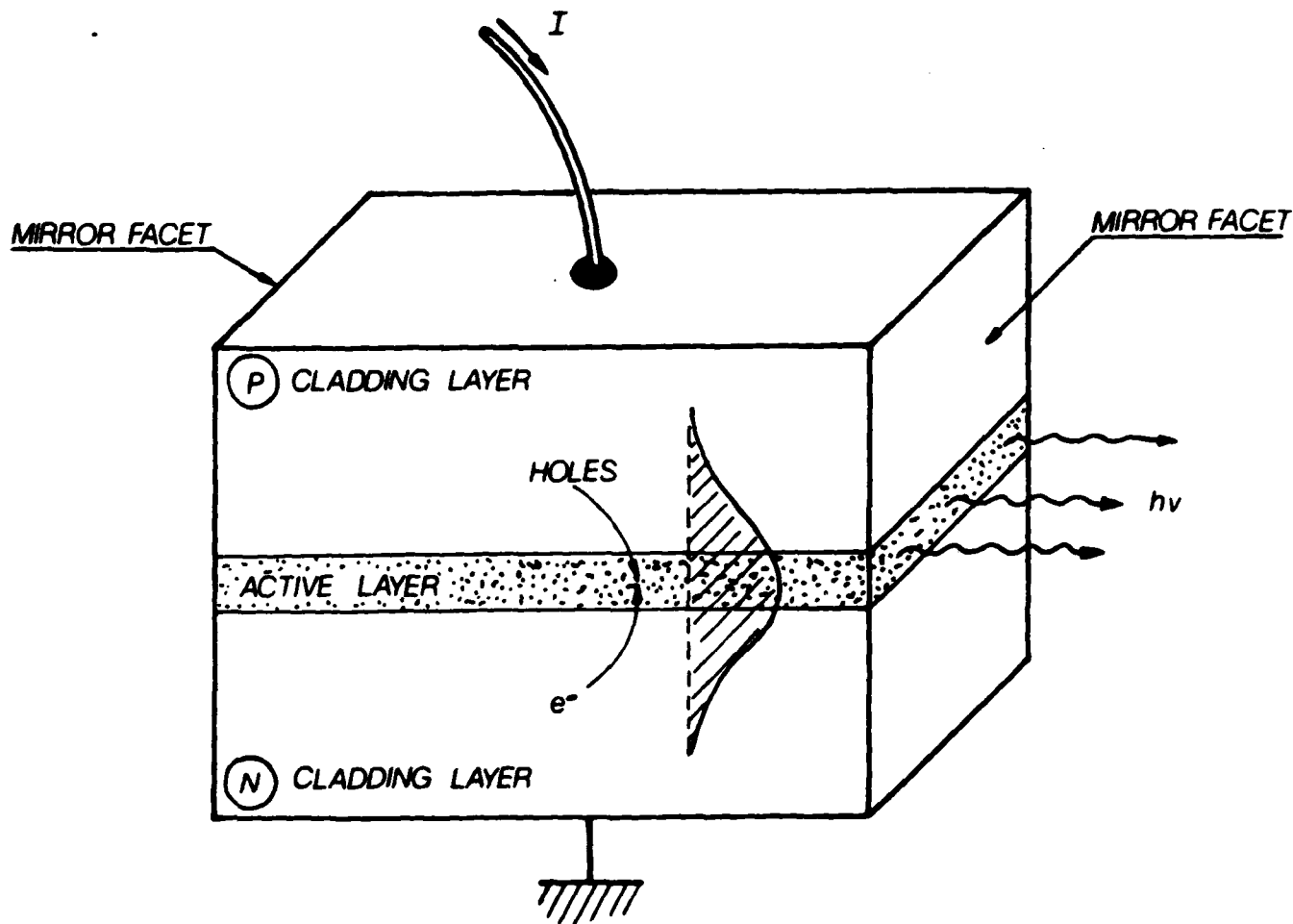

Figure 4. Schematic of the double heterostructure laser.

The positive feedback of the radiation is provided by a pair of cleaved facets that are perpendicular to the waveguide axis. The mirror reflectivity of the facets is given by the high refractive index of GaAlAs. For 6% aluminum, the refractive index is $n \approx 3.5$, which gives a reflectivity value of approximately 32%.

The lateral guiding of the optical wave is provided by the gain profile given by the injected carriers. The stripe width for the injection current is limited to obtain devices operating at a low threshold current. Furthermore, with a stripe width of about $4 \mu\text{m}$, only the fundamental transverse optical mode can propagate, this mode being stable up to high optical power output levels.

In order to prevent facet degradation, mirror facets are coated with an Al_2O_3 deposition. Thereafter, the individual lasers are mounted on a silicon stud, which is soldered to a heat sink for power dissipation (see Figure 5).

Light Current Behavior

By increasing the injection current starting at zero, the radiative carrier recombination is initially incoherent and gives a spontaneous emission. Above a critical forward current value, the "threshold current," the radiation becomes coherent, and the optical power output increases rapidly with the current. A typical light current characteristic is shown in Figure 6 for a Hitachi HL7801G laser diode operating in CW mode. The threshold and forward currents depend on the case temperature. The slope of the light current above threshold gives the external efficiency, η . A typical value for the external laser efficiency is $\eta = 0.2 \text{ W/A}$ per facet.

Far Field Patterns (FFPs) - Transverse Modes

The transverse mode of the Hitachi HL7801G is single. The transverse mode is defined by the spatial distribution of optical intensity of a laser beam. The full angle measured at half maximum points (FAHM) of the HL7801G is about 14 degrees (parallel to the junction) by 30 degrees (perpendicular to the junction).

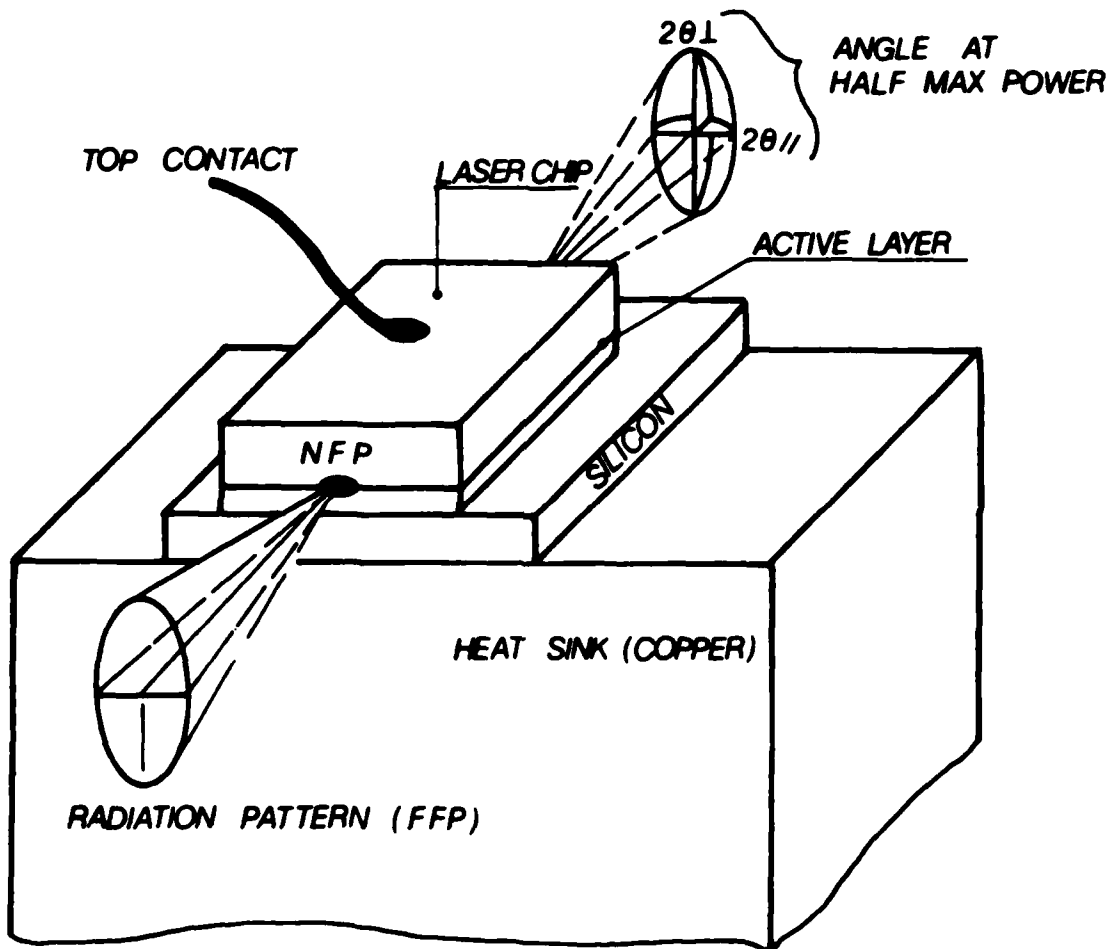

Figure 5. Schematic view of the laser on its heat sink.

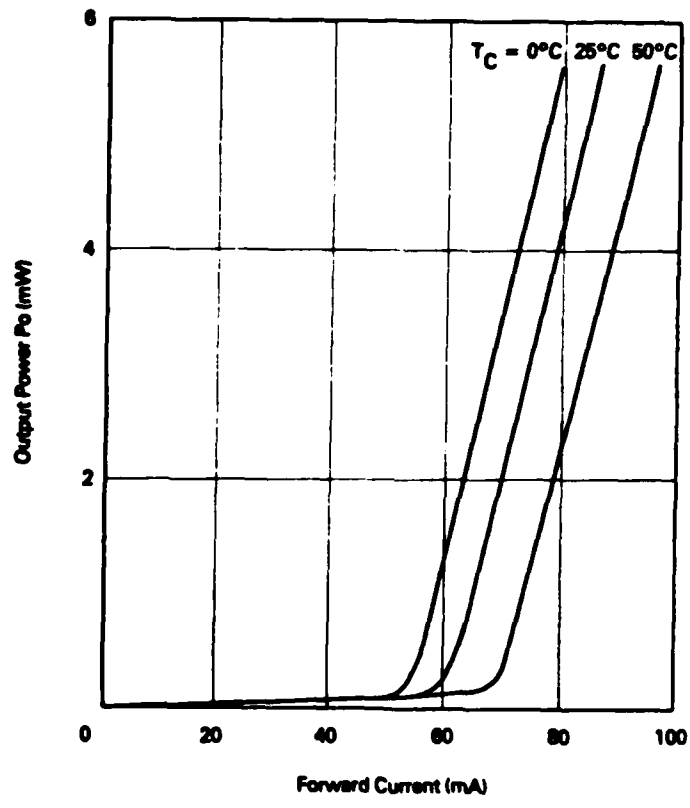

Figure 6. Output power versus forward current.

Optical Spectrum - Longitudinal Mode

The peak wavelength of the optical spectrum is controlled by the band gap energy of the active layer. The output spectrum of these gain-guiding lasers generally consists of several longitudinal modes (3 to 10 modes at half the peak power).

A semiconductor laser output spectrum is generally multimode. The spacing between modes $\Delta\lambda$ is a function of the wavelength λ , the effective refractive index of the optical cavity \bar{n} , and the length of the laser L:

$$\Delta\lambda = \frac{\lambda^2}{2 \bar{n} L} \quad (5)$$

At a 300- μm cavity length, $\Delta\lambda$ is approximately 0.28 nm.

By increasing the optical output power, the envelope of the spectrum narrows, and there is also a slight increase in peak wavelength, which results from the shift of the peak of the gain curve with current.

For use as the coherent light source in the DLDV, it is essential that the optical spectrum be single mode. Figure 7 shows the typical optical spectra at several output powers for the Hitachi HL7801G laser diode. The longitudinal mode of the HL7801G is almost single. For a single-mode diode laser, $\Delta\lambda$ is simply the bandwidth of the light. As the device temperature is raised, each longitudinal mode shifts to a longer wavelength, and the peak wavelength jumps to a longer wavelength. The typical average temperature coefficient of the peak wavelength is 0.2 to 0.3 nm/ $^{\circ}\text{C}$.

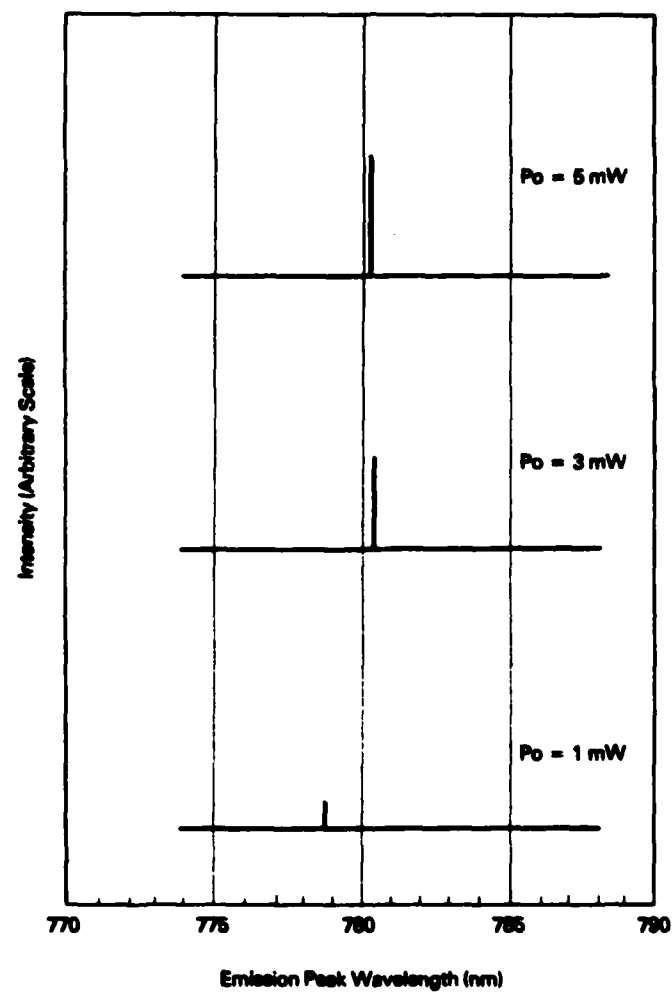

Figure 7. Output power dependence on emission spectra.

3. LABORATORY EQUIPMENT AND FACILITY

A series of experiments was conducted in FLOW's Fluid Mechanics Laboratory to demonstrate the feasibility of the development of the DLDV. The major laboratory equipment and facility used in the present research and development effort are described below. See Section 4 for a detailed description of the experimental setup and method.

3.1 Vertical Pipe Test Facility

Figure 8 is a drawing of the vertical pipe test facility in which the concept of the DLDV was tested. A low-turbulence water flow is fed from a constant-head tank through screens and honeycomb and then through a vertical acrylic pipe 5 cm in diameter. The water supplied to the tank is filtered through a 10 μm Culligan depth filter which contains an assortment of filtering aggregates including charcoal and pebbles of different sizes. The flow speed in the pipe was controlled by a valve below. Two platforms sliding on a pair of rails were used to mount the transmitting and collecting optics of the DLDV and the LDV using a 5 mW He-Ne laser. The latter was used to calibrate the performance of the DLDV.

3.2 Macrodyne Counter Processor

A counter-type signal processor (Macrodyne Model 2096) was used to process and validate the frequency information in the photodetector signals. It provides voltage output in both analog and digital forms proportional to the Doppler shift period, τ_d . This processor has been used successfully with another LDV system using an argon-ion laser as the light source. Measurements were made in a wind-wave tank to study the velocity spectra under breaking waves (Liu and Lin, 1984). In this feasibility study, we use the Macrodyne counter to examine the characteristics and quality of the burst signals. A bandpass filter (Krohn-Hite Model 3103) was used to filter the pedestal and high-frequency noise before feeding the output signals into the counter. Sample burst signals were recorded on floppy disks using a Nicolet oscilloscope (see Section 3.3).

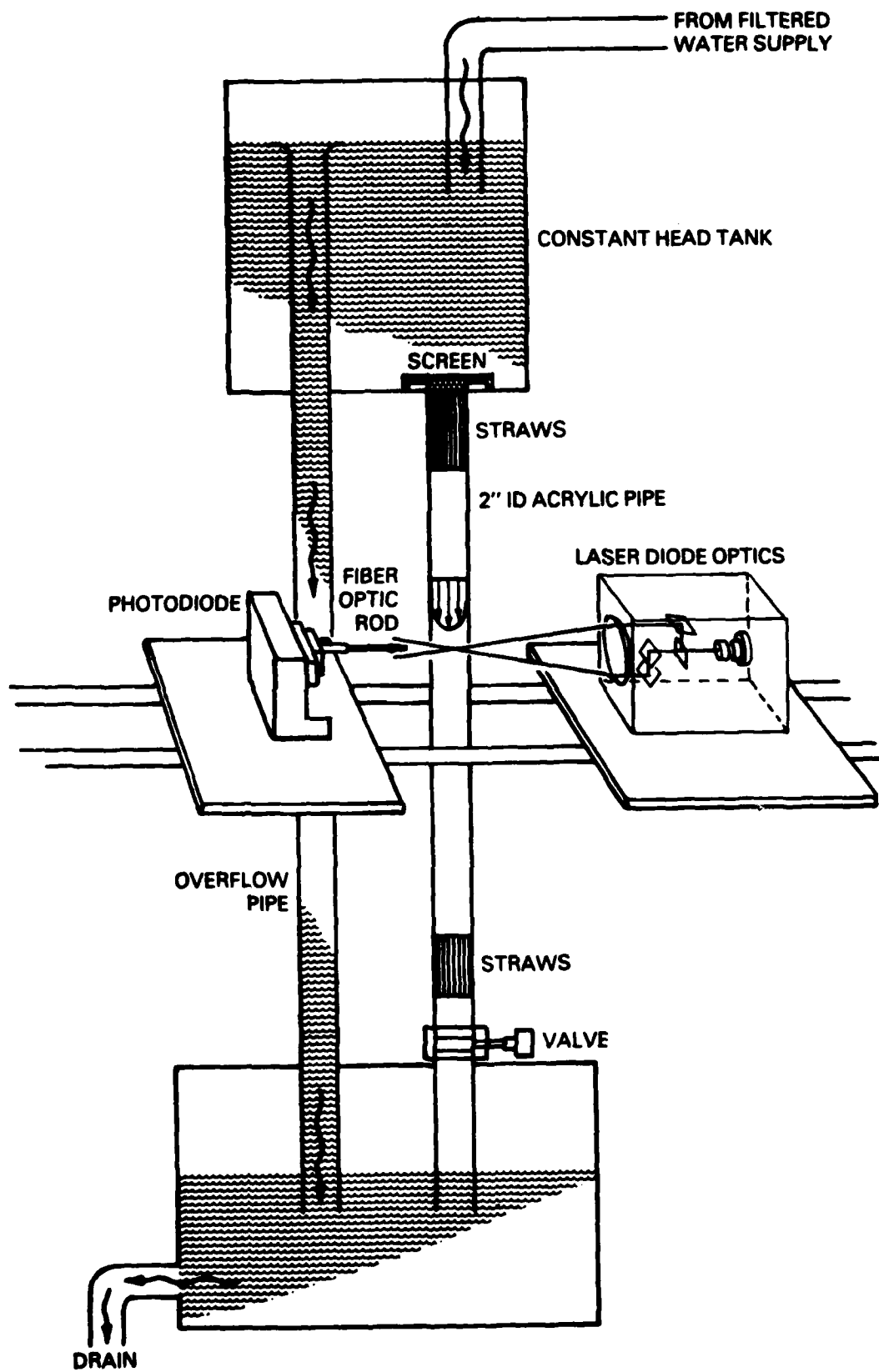

Figure 8. Vertical pipe test facility.

3.3 Nicolet Digital Oscilloscope

The Nicolet 4094 digital oscilloscope consists of three main components: the mainframe, the Model 4562 plug-in, and the XF-44/1 disk recorder. The mainframe includes a display memory, display screen, and various controls to manipulate the display screen components. The controls feature horizontal and vertical expansion to x256, autocentering, choice of XY and XT displays, 16K word display memory, which can be left intact or divided into halves or quarters, and multiple function abilities including arithmetic manipulations, electronic graticule, and pen recording outputs.

The Model 4562 plug-in includes two 12-bit, 500-nanosecond digitizers. Other plug-in features include: two high-impedance, differential amplifiers; single 16K word memory; single-ended or differential amplifiers; positive, negative or dual slope triggering; normal, pre- and post-trigger, and delayed trigger displays; a trigger view mode for setting up the triggering threshold; low-pass filtration, sweep and point averaging; etc.

The disk recorder transfers data onto the floppy diskette for storage. The stored data can be recalled at a later time for inspection on the screen. The diskette is divided into 20 individual records, each capable of storing either one (16K), two (8K), or four (4K) data groups. A set of 23 programs is available from the Stand Pak programs for statistical and waveform analysis of the signals stored on diskettes. For example, there are programs to estimate the maximum and minimum, the rise time of a wave form, the area, and the average and rms values. Programs are also available for differentiation, integration, and inversion of the signals.

4. PHASE I RESULTS

In this section we discuss the results of the Phase I work that relate to demonstrating the feasibility of the DLDV sensor. The significance of these results to the Phase II objectives is also discussed.

4.1 Laser Diode Characteristics

A review of the general characteristics of laser diodes is given in Section 2.2. Here we focus on those that are essential for use in laser Doppler velocimetry. The laser diode characteristics that are of the greatest importance include the wavelength of the emitted laser light and the laser coherence length. Other important characteristics are the diode laser output power and the divergence of the laser beam.

Wavelength

The wavelength of the light emitted by a laser diode is a very important factor to consider for underwater applications because of the rather narrow spectral window in which water has low absorption. Essentially this is restricted to the visible light spectrum, but moderate absorption extends into the near-ultraviolet and near-infrared wavelengths.

Many laser diodes emit in the infrared range at wavelengths greater than 1 micrometer, where absorption by water is very great. However, the desire for a very small, diffraction-limited spot size for optical data storage media has given impetus to the development of short-wavelength laser diodes. At the present time, there are a number of laser diodes available with wavelengths from the deep red (780 nm) to the near infrared (900 nm). This wavelength range (especially from 780 to 850 nm) can be suitable for use in a water velocimeter system.

Table 1 lists the extinction coefficient, κ , for light in the 750 to 900 nm range and that for blue-green light at 470 nm in seawater. For coastal water with high levels of particulates, these numbers may increase by about 0.5 m^{-1} . The light absorption obeys the exponential decay law given in the following equation:

$$I(x) = I_0 \exp(-\kappa x). \quad (6)$$

Table 1 also gives the distance in meters at which a 50% reduction in the initial beam intensity may be expected. Clearly, if there is not to be unacceptable signal loss, optical path lengths in water for laser diodes must be relatively short, on the order of 20 cm. Of course, this can be extended by using more powerful laser diodes. It also appears likely that continued progress in laser diode design will result in laser diodes with even shorter wavelengths in the visible spectrum.

TABLE 1. EXTINCTION COEFFICIENTS IN SEAWATER

Wavelength (nm)	Extinction Coefficient (m^{-1})	50% Attenuation Length (m)
750	2.7	0.25
800	2.4	0.29
850	4.1	0.17
900	7.0	0.10
532	0.10	6.9

Two laser diodes have been used in the Phase I feasibility study. These are an SCW-21 from Laser Diode Laboratories and an HL7801G made by Hitachi. Both are short-wavelength laser diodes. Table 2 lists optical and electrical parameters for the two laser diodes.

TABLE 2. LASER DIODE CHARACTERISTICS

	SCW-21	HL7801G
Output Power	7 mW	5 mW
Threshold Current	43 mA	40 mA
Peak Wavelength	822 nm	790 nm
Spectral Bandwidth	0.015 nm	-0.1 nm
Coherence Length	4.5 cm	0.7 cm

Coherence Length

After the peak wavelength, the coherence length, which depends on the spectral bandwidth, is the most important characteristic of the laser diodes. Many laser diodes have multiple longitudinal modes, as described in Section 2.2. This implies that laser diodes emit light at a number of closely spaced wavelengths. Typically, there is a central peak in the emission spectrum with less power radiated at a number of sideband peaks. If these sidebands are very low in power, the laser diode is in the single longitudinal mode, and it has a fairly pure, narrow bandwidth emission.

The spectral bandwidth of the laser diodes, designated $\Delta\lambda$, is generally defined as the wavelength band about the central peak that contains 50% of the total radiated power. A few laser diodes are available that have bandwidths on the order of 0.01 nm. Many multimode laser diodes, on the other hand, have bandwidths of 1 to 4 nm. A quantity that is related to the bandwidth is the coherence length. This is given by $\lambda^2/\Delta\lambda$, where λ is the peak wavelength of the emission spectrum. For a laser diode emitting at 830 nm and with a 1 nm bandwidth, the coherence length is 0.7 mm. But for $\Delta\lambda = 0.01$ nm, the coherence length becomes 7.0 cm.

The coherence length is a measure of the distance along the beam over which the light retains phase coherence. The coherence length of the laser diodes is important for the following reason. LDVs use the Doppler shift of the frequency of light scattered from moving particles to measure the particle velocity. (For small particles in water, with diameters less than 100 μm , the particle velocity is equal to the fluid velocity for all practical purposes.) As it is not possible to directly measure the light frequency, an interferometric technique is used. The scattered light is mixed with unscattered laser light, or more commonly with light scattered from a second beam, and a difference frequency is obtained. This differential frequency is equal to or a multiple of the Doppler frequency shift and can be measured with conventional photodetectors. It is necessary, however, that the interfering scattered light waves be coherent with one another. Otherwise, such rapid phase fluctuations will occur that the Doppler frequency will be unobservable.

The path lengths for the two light beams that are mixed on the photodetector surface must be equal to within the coherence length of the laser source if the Doppler signal is to be observable. If the coherence length is

very short, this implies that very careful control of the LDV optical setup is required. Slight misalignment, causing shifting of the optical path length will lead to significant degradation of the Doppler signal strength.

The availability of long-coherence-length laser diodes makes it easier to construct a laser diode-based Doppler velocimeter for field application. It is not difficult to design a system with optical path lengths equal to within 1 to 2 mm. Therefore, laser diodes emitting in the 800 nm region with a spectral bandwidth less than 0.2 nm (coherence length greater than 0.5 cm) should be satisfactory for use in the DLDV sensor. Single-longitudinal-mode laser diodes generally satisfy this criterion.

It is also desirable that the laser diode exhibit a single transverse mode. This implies that the spatial distribution of energy in the light beam emitted from the laser diode has a peak on the beam axis and falls off monotonically away from this peak. Many gas lasers, such as the helium-neon laser, produce fairly Gaussian energy distributions. While this characteristic is convenient for calculation of laser beam characteristics, it is not necessary for good performance in a laser Doppler system. It is desirable, however, that the light distribution be fairly smooth with a single maximum. More complicated patterns produce modulations of the light intensity in the sampling volume, which causes irregularities in the Doppler burst signal and lower quality Doppler signals. This ultimately results in a decrease in the overall SNR of the system.

Both of the tested laser diodes had single longitudinal and transverse mode behavior and satisfy the criteria set out above.

Laser Power

The radiated power of available CW laser diodes ranges from 2 to 20 mW. The tested laser diodes fall in the low to middle part of the range with output powers of 5 and 7 mW. Large power levels are not necessarily required for adequate DLDV performance. If the scattered light signals are sufficiently strong to raise the photodetector output above its inherent noise level, this will generally be adequate. In fact, much of the noise in the DLDV system is related to extraneous scattered light from the laser beams outside of the sampling volume. These noise levels increase along with the signal levels if laser power is increased. Power levels for laser diodes are similar to the

radiant power in many laboratory LDV systems, which often use helium-neon lasers in the 5 to 10 mW range. Thus it was felt that the diode lasers should be satisfactory in a DLDV system, at least when using forward-scattered light. The Phase I laser diode tests, discussed below, indicated that the selected laser diodes do have adequate power for forward-scatter measurements but would probably be marginal in a backscatter system.

Beam Collimation

Another factor determining the light intensity in the sample volume is the collimation of the laser diode beam. Figure 9 shows a typical laser diode structure with the radiated beam pattern and the intensity dependence along the two axes of the elliptical radiation pattern. It is necessary to collimate the radiated light into a nondiverging beam. In order to avoid the loss of a significant portion of the diode output, a large-numerical-aperture focusing lens with a short working distance must be used. While there are specialized laser diode collimation optics available, during Phase I we used a microscope objective for the beam collimation. With a 40 power objective, a numerical aperture of 0.65, essentially all of the laser diode output is collimated (there are, of course, some losses as the microscope objective lenses are not coated for optimal performance at the diode wavelength).

Just as the output of the laser diodes is a diverging elliptical cone, the collimated beam is also elliptical. While this can be modified using cylindrical lenses to produce a more circular beam, this was not felt to be necessary for the Phase I feasibility study. The elliptical beams cause the sampling volume to have an elliptical cross section perpendicular to the bisecting angle of the beams. This orientation can be chosen to control the number of fringes in the sampling volume (see Section 4.2).

Laser Diode Output Power Control

A characteristic of laser diodes that causes technical difficulties in their use is the need to control the output power of the laser diode under conditions of changing temperature. The power output versus current characteristics of laser diodes have a strong temperature dependence, typically 1 to 1.5% per degree centigrade. Thus, if the laser diode power is not controlled, laser power can easily rise to high levels when the diode is cooled (for

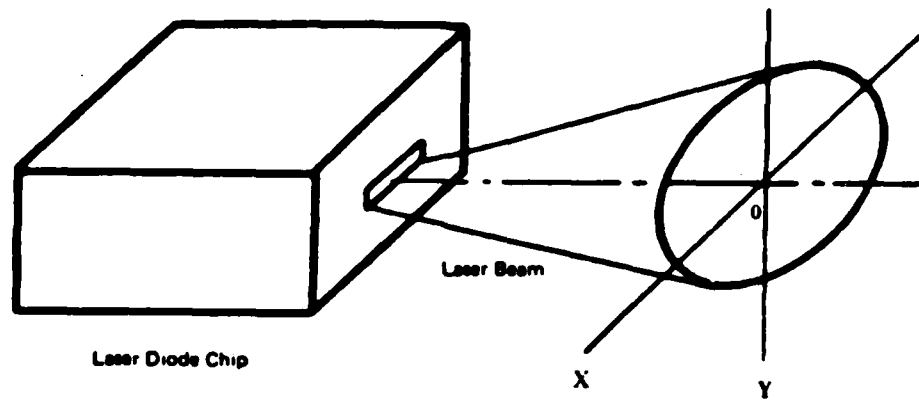

(a) BEAM PATTERN

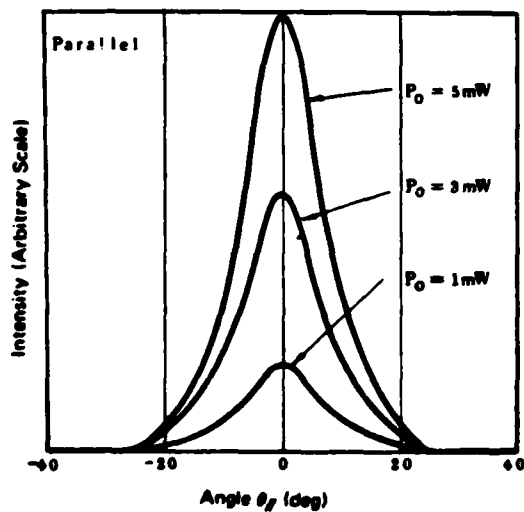

(b) BEAM SPREAD PARALLEL TO JUNCTION

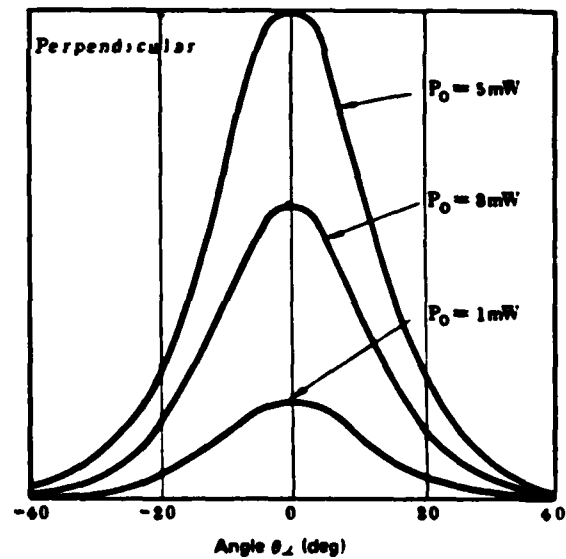

(c) BEAM SPREAD PERPENDICULAR TO JUNCTION

Figure 9. Light intensity distribution for HL7801G laser diode.

example, when lowered into deep water or in the Arctic). This will generally lead to failure or accelerated degradation of the laser diode.

Of less concern in the fairly constant temperature environment of an underwater pressure case are short period fluctuations in laser diode temperature. Small fluctuations in temperature of the laser diode will cause variations in laser output power. This appears as noise in the received detector signal. Some laser diodes incorporate a photodiode to monitor the output power. Using the current from this photodiode in a feedback circuit, it is possible to keep the laser power very constant. This is a desirable feature, particularly because the monitor photodiode makes it relatively simple to maintain constant laser power for large temperature excursions experienced when taking the instrument from the laboratory to the field.

Of the two diodes tested in Phase I, the SCW-21 does not have a monitor photodiode, while the HL7801G does. Two approaches will be considered in Phase II for the power control of laser diodes without a monitor photodiode. It is possible to place a photodiode to capture a small portion of the output beam (an optical fiber could be used to route a portion of the beam to a photodiode). Another technique would be to measure the temperature of the laser diode heat sink with a thermistor and use the thermistor in a laser diode current control circuit to vary the laser diode current with temperature. As the laser diode will be enclosed in a pressure case with significant thermal inertia, it is not anticipated that short period oscillations in temperature will be present. Therefore, the thermistor control circuit should work satisfactorily.

4.2 DLDV Optical Arrangement and Photodetector

While there are a number of possible optical configurations that might be used, we have chosen the dual beam-differential Doppler mode, or fringe mode. The general theory of LDV systems and commonly used optical configurations are discussed in Section 2.1. Phase I tests have indicated that using forward-scattered light will probably be necessary to provide adequate signal to noise for the Doppler signal.

Dual-Beam Configuration

Figure 10 is a schematic of the dual-beam configuration used for testing laser diodes in our laboratory. The beam from the laser diode is collimated by a microscope objective (40 power, numerical aperture of 0.65). The beam is then split by a cube beam splitter. The upper beam is reflected by a mirror, and the lower beam is offset either by a prism or a pair of mirrors to form two parallel beams. These beams are then crossed at the sample volume by the focusing lens. The upper mirror can be adjusted to provide equal optical path lengths for each beam. (Note that consideration must be given to the refractive index of the medium that each beam passes through in determining the optical path length.)

The dual beam-differential Doppler or fringe mode configuration for the DLDV has several advantages. First the optical system is simple and allows for easy alignment of the beams. The Doppler frequency observed depends only on the angle between the two beams, the laser light wavelength, and the flow speed and direction. Therefore the conversion of Doppler frequency to fluid velocity does not depend on the direction in which the scattered light is collected. This implies an absolute calibration that is not affected by minor misalignments in the collection optics.

Forward-Scatter Light Collection

A forward-scatter system for light collection has also been adopted for the DLDV prototype development. The primary reason for this is signal strength. Very good Doppler signals were obtained using forward-scatter light collection, either with a lens system or using a fiber optic rod described below. Attempts to use backscatter light pickup produced very weak or no Doppler signals. This is not too surprising, as the laser power was fairly low and backscatter intensity is 2 to 3 orders of magnitude weaker than forward-scattered light intensity. The backscatter signal strength could be improved by using a large collection aperture; however, this has bad consequences for flow disturbance. The present design uses a fairly small crossing angle for the two beams, about 7 to 10 degrees. This allows the sampling volume to be several diameters away from the focusing lens. This would not be possible with a large-aperture backscatter system, and increased flow disturbance would be inevitable.

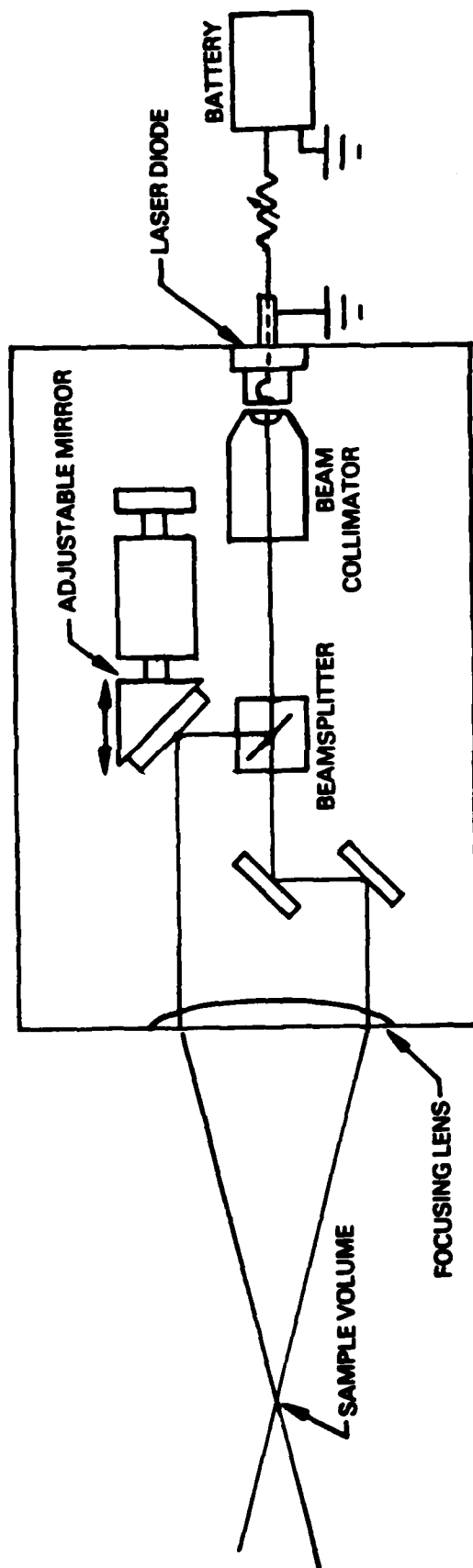

Figure 10. Diode laser Doppler velocimeter test configurations.

The photodetector used is a silicon photodiode with a built-in preamplifier. This photodiode has peak response in the wavelength region near the emission wavelength of the laser diodes tested. Also, the sensitive area of the photodiode is approximately the same as the diameter of the fiber optic rod. While there are more sensitive photodetectors available, such as avalanche photodiodes and photomultipliers, they require high supply voltages. One of the main advantages of laser diodes over gas lasers is that they require very modest driving voltages (less than 5 V). It seems undesirable to lose this advantage by using high-voltage detectors. In fact, results with the silicon photodetector have been very satisfactory.

4.3 Laboratory Testing

A number of tests have been carried out in the vertical pipe facility (Section 3.1) to examine the performance of the two laser diodes acquired during Phase I. The DLDV, dual-beam test unit described in Section 4.2 was mounted to allow measurement of flow velocity in the vertical acrylic pipe. The test facility was used for measurements with both the laser diodes and a 5 mW helium-neon laser. Characteristics of the DLDV system examined in the testing include beam collimation, coherence length, Doppler signal strength and signal to noise, forward and off-axis scattering, and alignment effects. The results of these tests are discussed below.

Beam Collimation and Focusing

As described in Section 4.2, the laser diode beam is collimated using a microscope objective lens. The resulting nondiverging beam is elliptical in cross section. The aspect ratio of this ellipse depends on the ratio of the two perpendicular beam divergence angles. For the SCW-21 laser diode, the resulting collimated beam produced a 1x5 mm spot on a phosphorescent viewing screen. The HL7801G laser diode produced an approximately 1.5x4 mm spot.

The collimated beam size, in combination with the focusing lens, determines the size and shape of the sampling volume and the number of fringes in the sampling volume. In the test facility, the angle between the two beams, which is controlled by the focusing lens, is 8 degrees. The volume of the beam crossing region was about 2 to 4x10⁻⁵ cm³ for the HL7801G and SCW-21 laser diodes, respectively. Both laser diodes were oriented to make the largest

cross-sectional sample volume dimension perpendicular to the fringe pattern. This produces the largest number of fringes and increases the sampling volume.

Control of the sampling volume size and the number of fringes is important for optimization of the sensor signal to noise and directly affects data rate and spatial resolution. This control, however, requires further optics to shape and expand (or contract) the beam diameter. The need for such optimization will be considered in the Phase II development. An important factor is the density of scattering particles in the ocean. Data from the temperate, open ocean (McCave, 1975; Mayo, 1979) indicate that, in the size range from 1 to 10 μm in diameter, the number of particles per cubic centimeter varies from 3000 to 30,000. The ultimate spatial resolution is determined by the larger of the sample volume size or the average distance traveled by water passing through the sample volume between observed particles. For the above range of densities and the prototype DLDV sampling volumes, the average distance traveled would be 0.7 to 0.03 cm depending on the density and the laser diode used. For a mean flow of 10 cm/s, the corresponding burst densities would be 14 and 300 bursts per second. The higher value is certainly adequate, even if we record at 48 samples/second. Note that the higher the mean flow speed, the higher the burst density. What particle densities are like in the Arctic remains to be seen. This is an example of the importance of field testing early in the Phase II effort. Observed scatterer densities will guide the optimization of the optical configuration.

Coherence Length

The laser diode optical test unit has a movable mirror in the upper beam path which allows the two beam paths to be precisely equal. Each of the lasers was tested in two different configurations. In one configuration, the lower beam was displaced by a pair of mirrors. The upper mirror was positioned to make the beam path lengths closely equal. Then the upper mirror position was varied and changes in the quality of the Doppler signals were observed. The path length difference could be varied from 0 to approximately 0.5 cm. In the second configuration, a prism was used to offset the lower beam. Because of the higher refractive index of the prism over an air path, the optical path length difference was approximately 2 cm. Again, the upper mirror could be moved to vary this difference from 1.5 to 2.5 cm.

Using the SCW-21 laser diode, the strength of the Doppler burst signals was not found to be significantly different between the 0 and 2 cm path length difference configurations. Similarly, no variation in signal strength was observed when the upper mirror was adjusted to vary the upper beam path length. These tests do not provide a direct measure of the laser diode coherence length. However, the results clearly show that the SCW-21 has sufficient coherence length that only roughly equal optical path lengths are required. This agrees well with the 4.5 cm coherence length calculated from the SCW-21 specifications.

The HL7801G indicated greater sensitivity to optical path length. This is to be expected, as its coherence length is considerably shorter than that of the SCW-21. Using the mirrors for equal optical path length, the upper beam path length could be varied by about 4 mm with no apparent effect on Doppler signal quality. However, when the prisms were used to offset the lower beam, no Doppler signal could be obtained. Thus, with this laser diode, somewhat greater care is required in the optical design to ensure equal path lengths. The coherence length is great enough to make small differences of a few millimeters unimportant. This is satisfactory to ensure that minor changes, inaccuracies, or shifts in path length do not degrade the sensor performance.

The Phase I tests indicate that either of these laser diodes should be satisfactory for use in the prototype underwater DLDV sensor and for the Phase II development.

Scattered Light Collection

The typical method used for collection of the scattered light providing the Doppler signal is to use lenses to focus the scattered light onto a photodetector. Light stops and pinholes are generally used with the focusing lenses to carefully define the sample volume (i.e., some portion of the beam crossing region) from which the scattered light is collected (Durst et al., 1976). The disadvantage of such systems in a field instrument is that the optics must be precisely aligned. A slight shift may move the imaged location out of the beam crossing entirely. Unfortunately, unless a field instrument is robust, slight misalignments are inevitable. Making the instrument very robust is not likely to be compatible with the mission of a turbulence measuring instrument. A backscatter system in which all optics are contained in one housing has a

better chance of maintaining alignment. However, as discussed below, a back-scatter system does not appear to be practical with the laser diodes tested.

We have also examined the use of a fused fiber optic rod for collection of the scattered light (Shaughnessy and Bifano, 1983). Scattered light falling on the end of the rod is internally reflected by the individual fibers (about 70,000 in the rod used) and routed to the photodiode detector. The diameter of the rod is about 3 mm. Therefore, it can be brought to within 2 to 3 cm of the sampling volume without introducing significant flow disturbance. The larger housing for the photodiode can be placed considerably farther away. An interesting feature is the possibility of bending the fiber optic rod to route the light to the most convenient location for placement of the photodetector.

An advantage of the fiber optic rod is that it is fairly insensitive to misalignment. Laboratory tests have shown that misalignment of the rod by a few degrees from the optical axis of the laser beams has no significant effect on signal strength. This is due to the large acceptance angle of the fiber optic rod. To some degree, this can also be a disadvantage, as more extraneous light is collected including light scattered from particles passing through the beams but not through the sampling volume (beam intersection point). This increases the noise level of the detector output. Placing a light shroud over the end of the fiber optic rod greatly reduces this noise by blocking light scattered from particles passing through the laser beams near the end of the rod (see Figure 11). In Phase I laboratory measurements, the noise was not found to be a problem except in cases where there was a very large number of scatterers in the water (where the water had a cloudy appearance through even a 4 or 5 cm path length). While lenses and masks can be used, as discussed above, to reduce the effect of extraneous scattered light, the price paid is much greater sensitivity to alignment errors.

We plan to use the fiber optic rods in the initial prototype sensor. Phase I results have shown this approach to work well, and use of the rods will provide greater flexibility in the design of the multi-axis DLDV sensor to be developed in Phase II.

Signal Quality: Helium-Neon Laser Comparisons

Measurements were made in the pipe flow with both the laser diodes and with a helium-neon laser using the same optical system. The purpose was to

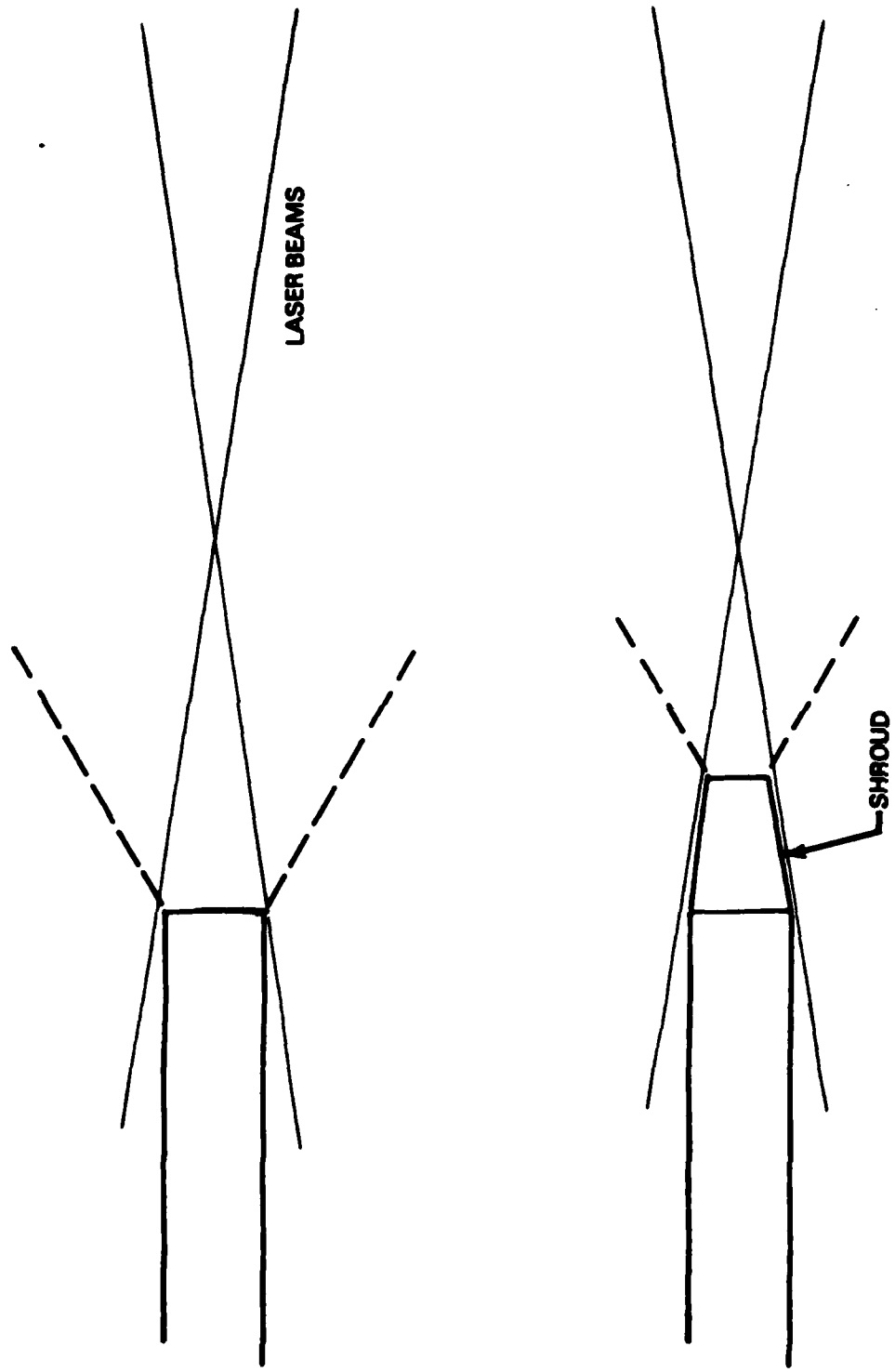

Figure 11. Fiber optic rod light collection with and without shroud.

compare the quality of the Doppler bursts obtained with the laser diodes with the signals obtained with a conventional LDV laser source. The He-Ne laser has a 5 mW output, which is similar to the laser diodes tested.

There are some differences in the optical characteristics of the two systems aside from the shorter wavelength of the He-Ne radiation. The He-Ne laser beam was expanded, and the measuring volume cross-sectional area was smaller than that of the laser diodes by a factor of 2 to 3. The number of fringes in the He-Ne system sampling volume appeared to be about 20, while there were 50 to 60 in the laser diode sampling volumes. This indicates that the average light intensity in the sampling volume was higher for the He-Ne system. In fact, the average Doppler burst amplitude appeared to be higher for the He-Ne system by about a factor of 2. Figure 12 shows a somewhat larger than average burst obtained with the He-Ne laser system, and Figure 13 shows an average burst with the laser diode. Both bursts were obtained from tap water passed through a 10 μm filter.

While the Doppler burst amplitude with the He-Ne laser was higher on average than that obtained with the laser diodes, the noise level was lower for the laser diodes. Thus the signal-to-noise ratio, considered as the ratio of the rms voltage in a Doppler burst to the rms background noise in the photodetector output, was found to be essentially equivalent.

Due to the different wavelengths of the laser diode and He-Ne laser light, the fringe spacing in the laser diode sampling volume was about 6 μm , while that for the He-Ne laser system was about 4.5 μm . Durst (1973) indicates that the optimal scattering particle has a diameter one-fourth the fringe spacing. However, good Doppler signals are obtained with particles of one-half to 10 or 20 times this optimal size (Durst et al., 1976).

The noise level at the output of the photodetector for the laser diode system was approximately 0.2 mV rms for a bandwidth of 50 to 200 kHz. This corresponds to 8×10^{-12} W per square root hertz. This is a factor of 3 higher than the rated noise level of the photodetector. It is likely that some further gain in SNR can be obtained with optimization of the detector circuitry. With the present configuration, for average particles in tap water, the ratio of the rms Doppler burst voltage to the adjacent noise was 10 to 20. Some measurements were also carried out with graded latex spheres with diameters from 1 to 10 μm . The above SNR was maintained fairly well over

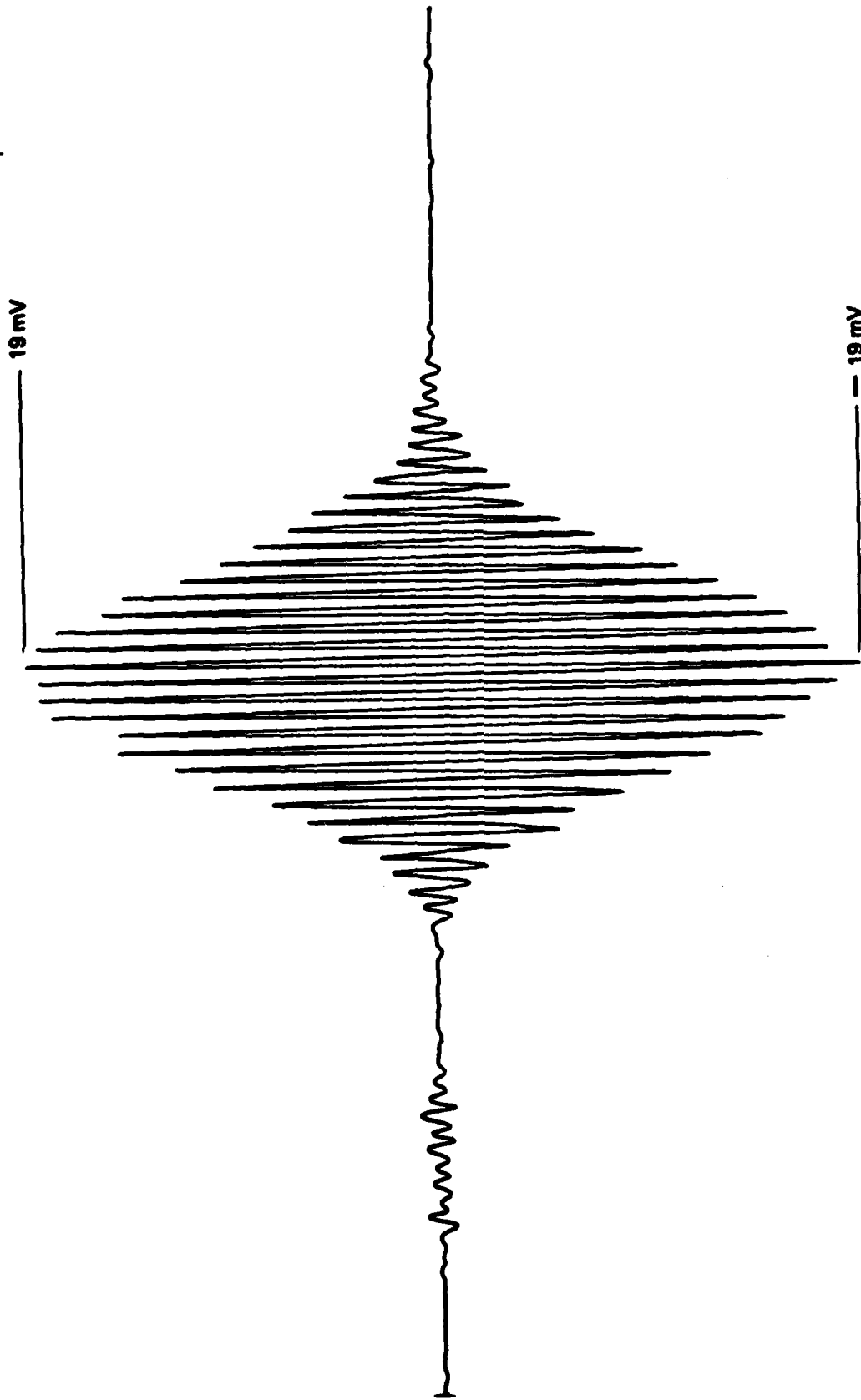

Figure 12. Large Doppler burst with helium-neon laser using lenses to focus scattered light on photodiode. Filter bandpass — 25-70 kHz. Background noise — 0.24 mV rms. Doppler frequency — 57.8 kHz = 28.4 cm/s.

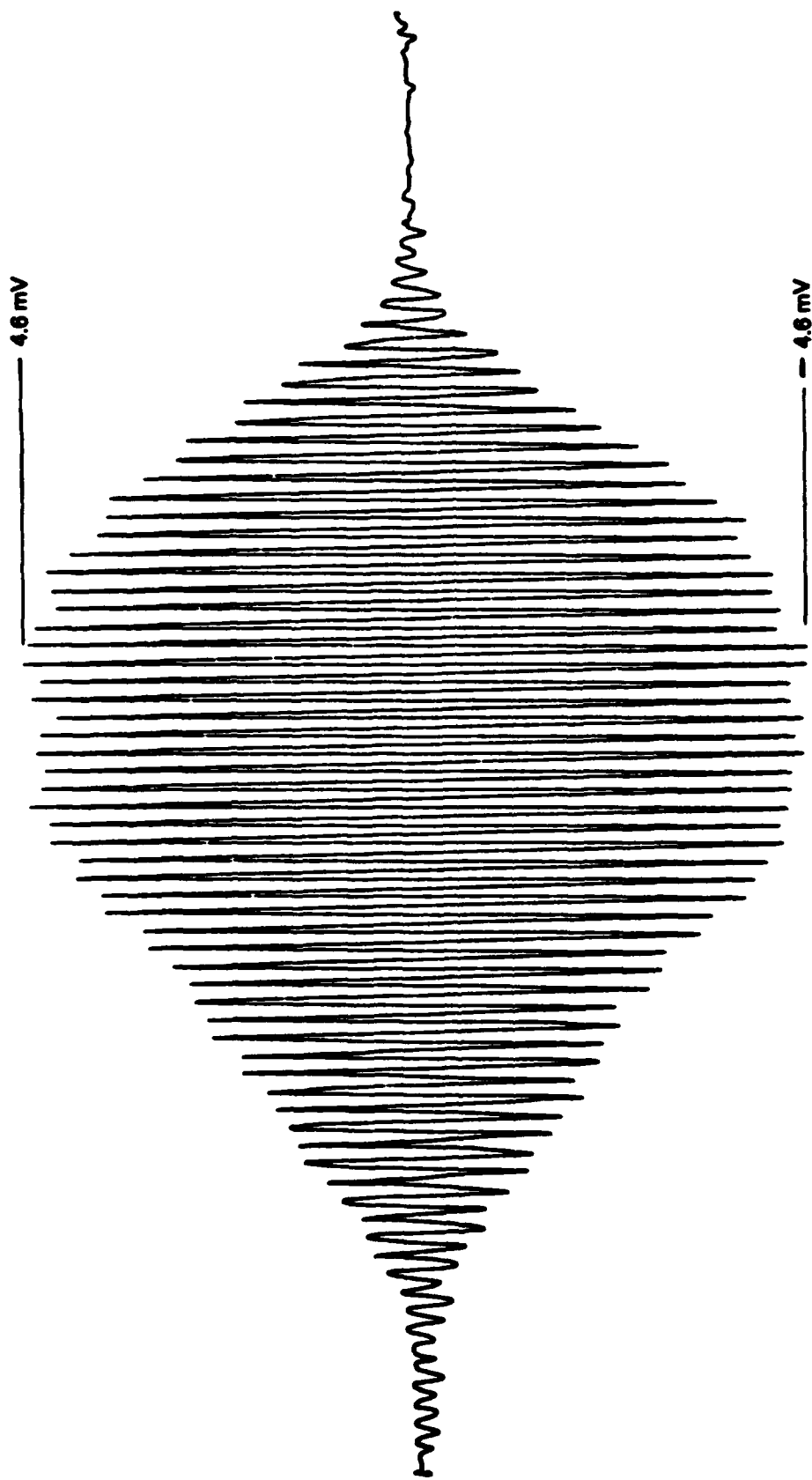

Figure 13. Typical Doppler burst with SCW-21 laser diode and fiber optic rod pickup. Filter bandpass — 40 to 200 kHz. Background noise 0.09 mV rms. Doppler frequency 85.9 kHz = 51.0 cm/s.

this range of particle sizes with an increase by a factor of approximately 1.5 to 2 for the larger particles. Oceanic particle measurements reported by McCave (1975) indicate that this range of particle sizes has a fairly uniform number density throughout most of the open ocean. Thus, we anticipate that the DLDV sensor will be well matched to available scatterers in the ocean.

The above comparison has clearly demonstrated that the performance of the DLDV is at least as good as a well-established LDV system using a He-Ne laser as the light source. Therefore, the feasibility of the DLDV for laboratory deployment is definitely established. To increase the burst density, we have found that powdered milk, which forms particles on the order of a few microns when dissolved in water, works satisfactorily. Preliminary tests were also conducted using Puget Sound water added to the tap water. Very good burst signals with high burst density were observed. The results suggested strongly that, unless it is diluted properly, there might be too many particles in the Puget Sound water.

To determine the deployability in the MIZ environment, we plan to test two single-component DLDVs during MIZEX 84. The test results will answer several crucial questions regarding the performance of the DLDV and, thus, the high-resolution DLDV-T/C clusters in that environment. Among these are the number density and size distribution of particles ranging from 1 to 10 μm and the effect of temperature. The results obtained from the MIZEX tests and from the Phase I study will provide the necessary groundwork for the construction of the DLDV-T/C clusters to be deployed during AIWEX 85.

Forward and Off-axis Scattering

During Phase I some measurements have been made to assess the signal strength for forward scattering as compared to off-axis and back scattering. The results have indicated that forward scattering should be used in the prototype DLDV sensor used in field testing.

Typically, forward-scattered light is 2 to 3 orders of magnitude more intense than backscattered light for the small scattering particles used by an LDV system (Fingerson and Adrian, 1978). In our test we collected light scattered from the sampling volume into a fairly small cone (about 5 to 7 degree included angle). This is scattered light that lies between the two laser beams. With this arrangement we were not able to observe Doppler signals using

backscatter and our photodiode as a detector. Several approaches might be used to improve backscatter performance: use of a photomultiplier tube, larger light collection aperture, and greater laser power. Use of a photomultiplier tube negates the low-voltage power supply advantage of the laser diodes. A larger light collection aperture requires that the optics be farther removed from the sample volume, but this is not possible for laser diode wavelengths. CW laser diodes are not available with greatly increased power levels. Pulsed laser diodes might be used to achieve high power levels, but the development of a pulsed LDV would require a considerable development effort, which is not contemplated for Phase II.

Off-axis scattering in the forward direction indicates a fairly rapid falloff of signal strength with angle. The Doppler signal strength fell to about 50% of the on-axis values at an angle of 10 degrees. When the angle is increased to 30 degrees, the signal strength was estimated to be reduced by an order of magnitude from the on-axis forward scattering. This was too weak for satisfactory Doppler processing with the present system.

While it may be possible to decrease flow disturbance by using off-axis light collection, it is planned to use on-axis forward scatter in the prototype sensor. This is due to a desire to provide a system for the field test which will have the best possible chance of obtaining high-quality Doppler signals. Use of off-axis scattering will be further examined during Phase II, as it may be very useful in reducing flow disturbance in multi-axis DLDV systems.

4.4 DLDV Prototype Design

From the above Phase I results, the probability of the successful development of a working DLDV sensor appears to be very high. A significant part of the Phase II effort is directed toward optimization of the laser diode and optical arrangement to enhance the signal to noise of the instrument in the ocean environment. We will also be developing Doppler signal analysis electronics to provide a complete sensor system. Refinement of the overall sensor design will be pursued to reduce as much as practical flow interference while retaining a rugged sensor that can be expected to survive in field conditions. This implies that the design should also allow field maintenance and easy replacement of critical, vulnerable parts. In particular, this includes the laser diode, the photodetector, and the fiber optic rod used for light pickup.

The optical design and underwater prototype sensor design developed during Phase I has taken these needs into consideration. The prototype DLDV design is shown in Figure 14, with details of the laser optics in Figure 15. The laser diode collimation, beam splitting, and focusing optics are aligned using a helium-neon laser and rigidly mounted in the laser diode pressure case. Use of the Helium-Neon laser simplifies this procedure as the beams are visible.

The laser diode is placed on a mount that allows adjustment for proper beam collimation and for beam centering. This is a fairly simple operation that is carried out using three fine adjusting screws and a fluorescent screen to allow the infrared beam to be observed. If a laser diode fails, the sensor is designed to allow easy replacement, and only the laser diode alignment needs to be adjusted.

Similarly, the photodetector is placed in a socket for easy replacement, and the fiber optic rod is built into a separate holder that fits into the detector pressure case. Thus, if the fiber optic rod were broken, it could be easily replaced. As indicated previously, the fiber optic rod has a large acceptance angle for the scattered light and thus alignment is not very critical. This allows simple alignment of the entire detector pressure case using the beam locations relative to the fiber optic rod (as indicated by a phosphorescent screen).

The laser optics and photodetector pressure cases are held in a C-shaped frame. Both cases are held in tubes. The laser optics case is fixed in orientation, but the photodetector case can be adjusted for alignment. This also allows for the need to realign the system in the field. Two of the frames can be easily attached to one another with sensitive axes at right angles to provide a two-component measurement. Note that the DLDV sensor is sensitive to flow perpendicular to the gap in the C and in the plane of the frame. In the initial field experiment, the sensor will be oriented with the gap facing into the mean flow.

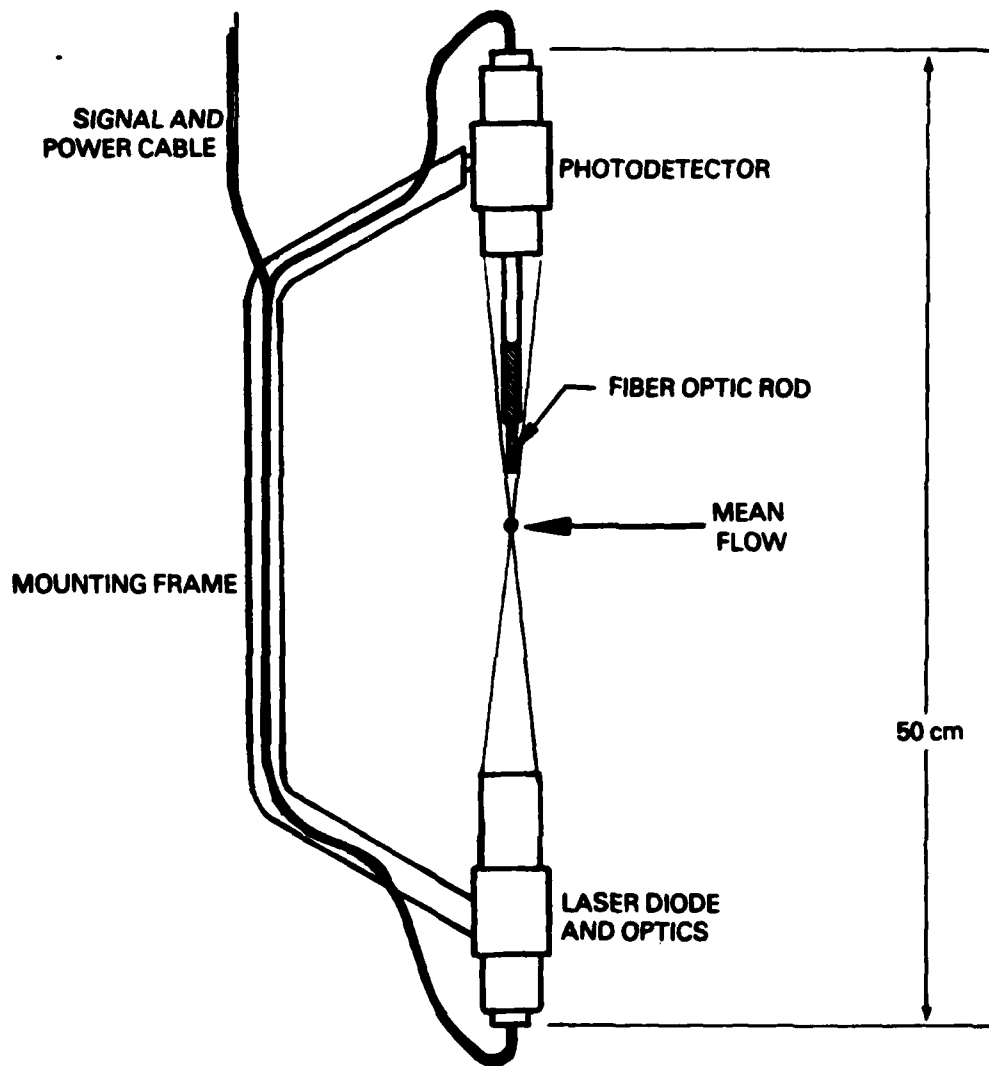

Figure 14. Prototype DLDV design for field test.

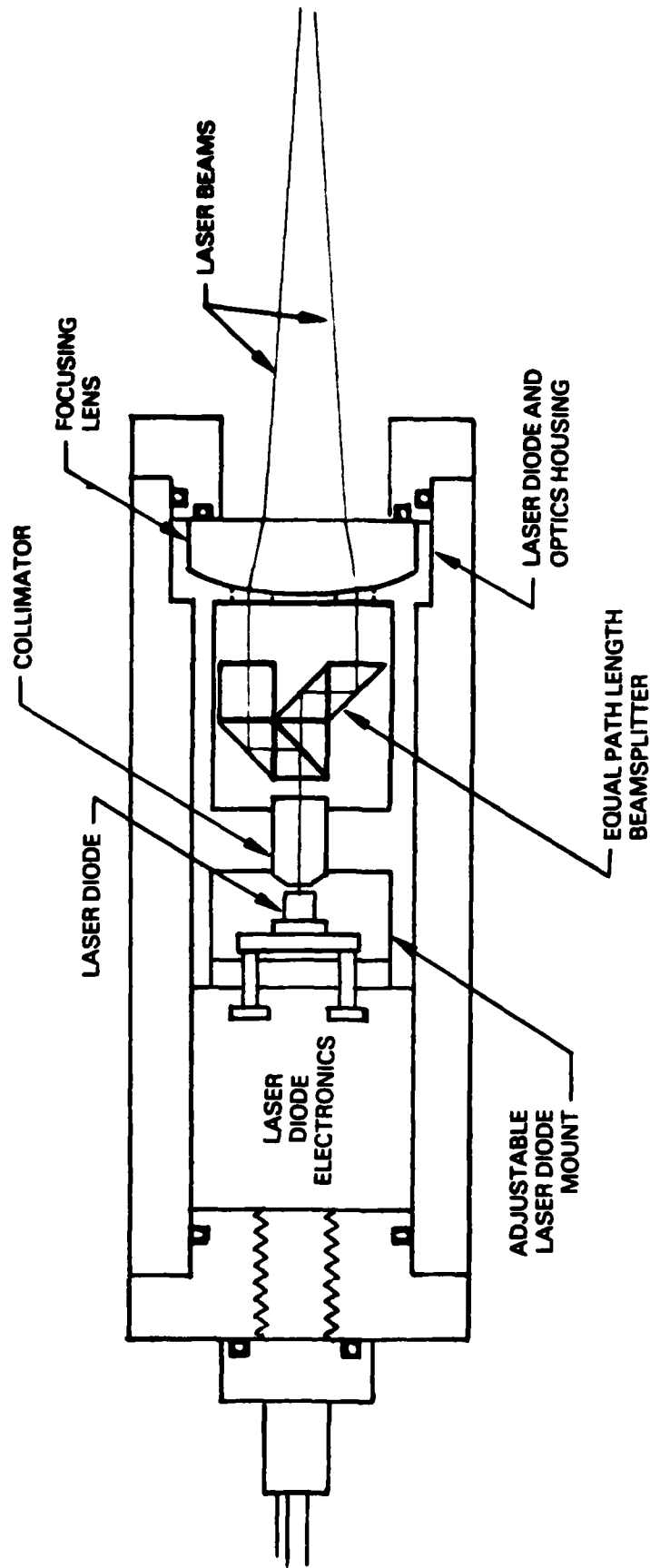

Figure 15. Underwater DLDV laser diode optic module.

5. CONCLUSION AND RECOMMENDATIONS

This Phase I feasibility investigation of developing a diode laser Doppler velocimeter (DLDV), to be used as the velocity sensor in a high-resolution velocity/temperature/conductivity cluster for measurement of turbulent fluxes in the Arctic Ocean, has been completed through a literature search, design and assembly of a breadboard DLDV and laboratory testing. The results have clearly demonstrated the feasibility of such a development. More conclusive results on the field adaptability of the DLDV-temperature/conductivity clusters will be obtained from the Phase II field experiments during MIZEX 84. In this section, we summarize the essential findings of the successful Phase I feasibility investigation. We then give recommendations for the Phase II research and development effort, which will lead to the construction of prototype DLDV-T/C clusters and their deployment during AIWEX 85.

- (1) Two diode lasers, a 7-mW SCW-21 ($\lambda = 830$ nm) by Laser Diode Laboratories and a 5-mW HL7801G ($\lambda = 793$ nm) by Hitachi, were selected as the coherent light sources for the DLDV. Both have single-mode characteristics and relatively short wavelengths; the latter is essential for avoiding strong attenuation of the light intensity in water, an important requirement for a water velocimeter (Section 4.1). Both lasers proved to have adequate optical power and coherent length to form a distinct fringe pattern at the focal volume when viewed with a microscope objective.

- (2) A breadboard unit of a DLDV was assembled, by adopting the dual-beam fringe mode and forward-scatter collection with a fiber optics rod (Section 4.2), and the unit was tested in a vertical pipe flow facility (Section 4.3). The performance of the DLDV proved to be at least as good as an LDV using a 5-mW helium-neon laser. While the amplitudes of the DLDV Doppler burst signals are lower than those of the LDV, the noise level of the former is also proportionally lower than that of the latter. As a result, the signal-to-noise ratio (SNR) is comparable for the two systems. The focal volume of the DLDV is about 2 to 4×10^{-5} cm³ within which there are about 50 to 60 fringes with a spacing of 6 μ m. The focal volume of the LDV with

the He-Ne laser is about 10^{-6} cm^3 within which there are about 20 fringes with a spacing of $4.5 \text{ }\mu\text{m}$.

- (3) Under an extreme condition, when using clear tap water passed through a $10\text{-}\mu\text{m}$ filter as the working fluid, the DLDV produced occasional Doppler burst signals most of which were of "textbook" quality with very good SNR (see Figure 13). When Puget Sound water or a dilute solution of powdered milk was added to the tap water, excellent Doppler bursts with high burst density were registered on the oscilloscope. Without proper dilution, the particle density in the Puget Sound water could have been too high for optimum operation of the DLDV. Although we anticipate that the particle density in the MIZ environment may not be as high as that in Puget Sound, it may be comparable to that in the dilute solution, in which the DLDV works satisfactorily. Data from the temperate, open ocean also indicate that the particle density is reasonably high and that a burst density on the order of 100 bursts per second is attainable at a mean flow of 10 cm/s (Section 4.3).
- (4) We have designed and partly assembled a prototype DLDV (Figures 14 and 15, Section 4.4) to be deployed in MIZEX 84. Provisions have been incorporated into the design for easy replacement and subsequent realignment of optical components in the field.
- (5) Based on the encouraging Phase I findings, we strongly recommend that further research and development be conducted to improve the design of the DLDV and, equally important, to assess the field adaptation of the DLDV especially in the Arctic Ocean. Consequently, we have submitted a Phase II proposal (Flow Industries TP-8469) for major research and development efforts toward the construction of three high-resolution DLDV-T/C clusters to be used during AIWEX 85 for measurements of turbulent fluxes of momentum, heat, and salinity. These clusters will have a spatial resolution of 1 to 2 cm. Each cluster will have a three-component DLDV together with a miniature conductivity sensor and a fast-response thermistor. Prior to the

construction of the clusters, two single-component DLDVs will be deployed during MIZEX 84 to obtain necessary information for assessing the performance of the DLDV in the MIZ environment. Our proposal (TP-8469) presents the detailed research and development plan for the Phase II work.

- (6) Supported by Phase II interim funding, we are currently assembling two single-component DLDVs to be deployed during MIZEX 84. Laboratory testing and calibration of the DLDVs are in progress to ensure proper operation of the units in the field. Other preparations are being made for our participation in MIZEX 84. We will soon look into potential techniques that can be integrated into the three-component DLDVs to eliminate the directional ambiguity inherent in laser velocimetry.

REFERENCES

- Businger, J. A. (1975) "The Need for Boundary-Layer Measurements and Their Significance for Solving Atmospheric Problems," Atmos. Tech., No. 7, pp. 2-6.
- Colella, G. M., and Neti, S. (1982) "Development of a Fiber Optic Laser Doppler Anemometer for Bubbly Two Phase Flows," Proceedings of the Symposium on Engineering Applications of Laser Velocimetry, Phoenix.
- Durst, F. (1973) "Scattering Phenomena and Their Application in Optical Anemometry," ZAMP, 24, 619.
- Durst, F., Melling, A., and Whitelaw, J. H. (1976) Principles and Practice of Laser Doppler Anemometry, Academic Press, New York, 405 pp.
- Fingerson, L. M., and R. J. Adrian (1978) "An Intensive Course in Laser Velocimetry," TSI LDV Short Course Notes, Thermos-Systems Incorporated, St. Paul, Minnesota.
- Johannessen, O. M., Hibler, W. D. III, Wadhams, P., Campbell, W. J., Hasselman, K., and Dyer, I. (eds.) (1983) "MIZEX, A Program for Mesoscale Air-Ice-Sea Interaction Experiments in the Arctic Marginal Ice Zone: II. A Plan for a Summer Marginal Ice Zone Experiment in the Fram Strait/Greenland Sea: 1984," U.S. Army Cold Regions Research and Engineering Laboratory, Hanover, N.H. in press.
- Kaimal, J. C., Wyngaard, J. C., Haugen, D. A., Cotie, O. R., and Izume, Y. (Caughey, S. J., and Reddings, C. J., eds.) (1976) "Turbulence Structure in the Convective Boundary Layer," J. Atmos. Sci., 33, 2152-2169.
- Knuhtsen, J., Ollidag, E., and Buchhave, P. (1982). "Fiber Optic Laser Doppler Anemometer with Bragg Frequency Shift Utilizing Polarization-Preserving Single Mode Fiber," J. Phys. E (Sci. Instrum), 52, 1188-1191.
- Liu, H.-T., and Lin, J.-T. (1982) "On the Spectra of High-Frequency Wind Waves," J. Fluid Mech., 123, pp. 165-185.
- Liu, H.-T., and Lin, J.-T. (1984) "Measurements of Wave-Variance and Velocity in Breaking Waves," Submitted to J. Fluid Mech.
- Mayo, W. T. Jr. (1979) "Ocean Laser Velocimetry Systems: Signal Processing Accuracy by Simulation," in Laser Velocimetry and Particle Sizing, Proceedings of the Third International Workshop on Laser Velocimetry, Vol. 1, Stevenson and Thompson (eds.), Purdue University, Hemisphere Publishing Corporation, Washington, D.C., pp. 473-483.
- McCave, I. N. (1975) "Vertical Flux of Particles in the Ocean," Deep-Sea Research, 22, 491-502.

- McMurray, J. T., and Shaughnessy, E. J. (1982) "Measurement of Turbulence in a Tidal Channel Using a Laser Doppler Velocimeter," Proceedings of the Symposium of Engineering Applications of Laser Velocimetry, Phoenix.
- McPhee, M. G. (1981) "An Analytic Similarity Theory for the Planetary Boundary Layer Stabilized by Surface Buoyancy," Boundary-Layer Meteorol., 21, 325-339
- McPhee, M. G. (1983) "Turbulent Heat and Momentum Transfer in the Oceanic Boundary Layer Under Melting Pack Ice," J. Geophys. Res., in press.
- McPhee, M. G., and Schedvin, J. C. (1984a) "Development of an Ocean Boundary Layer Measurement System," Paper 41A-07 presented at American Geophysical Union, Ocean Sciences Meeting, January 23-27, New Orleans, Louisiana.
- McPhee, M. G., and Schedvin, J. C. (1984b) "Preliminary Calibrations: MIZEX Moderate-Resolution Turbulence Clusters," Report 84-2, McPhee Research Company, Yakima, Washington.
- McPhee, M. G., and Smith, J. D. (1976) "Measurements of the Turbulent Boundary Layer under Pack Ice," J. Phys. Ocean., 6, No. 5, pp. 711-969.
- Mellor, G. A., and Durbin, P. A. (1975) "The Structure and Dynamics of the Ocean Surface Mixed Layer," J. Phys. Ocean., 5, 718-728.
- Ohba, K., and Matsuno, T. (1982) "Local Velocity Measurements of Opaque Fluid Velocity Using Laser Doppler Velocimeter with Optical Dual Fiber Pickup," Proceedings of the Symposium on Engineering Applications of Laser Velocimetry, Phoenix.
- Shaughnessy, E. J., and Bifano, T. G., (1983) "Measurements of the Energy Spectrum in a Tidal Channel Using a Second Generation Submersible Laser-Doppler Anemometer," Eighth Biennial Symposium on Turbulence, University of Missouri, Rolla, September.
- Shaughnessy, E. J., and Zu'Bi, F. H. (1978) "GaAlAs Diode Sources for Laser-Doppler Anemometry," Applied Physics Letters, 33, No. 9.
- Simpson, J. J., and Dickey, T. D. (1981) "The Relationship Between Downward Irradiance and Upper Ocean Structure," J. Phys. Ocean., 11, 309-323.
- Stevenson, W. H. (1979) "A Historical Review of Laser Velocimetry," Laser Velocimetry and Particle Sizing, Hemisphere Publishing Corp., Washington, D.C.
- Thermo-Systems, Inc. (1979) "Laser Velocimetry Technical Data," TSI Technical Bulletin No. 25.

END

FILMED

11-85

DTIC