

AD-A145 240

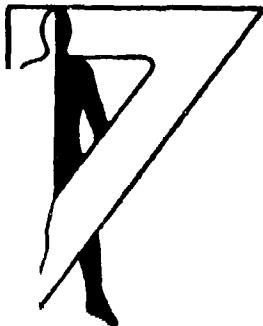

AD

Technical Memorandum 10-84

DEVELOPMENT OF ADVANCED TECHNOLOGY FOR QUIET VEHICLES
EXPERIMENTAL QUIET ROADARM DESIGN

Jerome A. Schmiedeberg
Karl G. Turner
Thomas R. Norris
Georges R. Garinther

July 1984
AMCMS Code 691000

Approved for public release;
distribution unlimited.

DTIC
ELECTE
SEP 5 1984
S D
D

U. S. ARMY HUMAN ENGINEERING LABORATORY
Aberdeen Proving Ground, Maryland

84 09 04 018

DTIC FILE COPY

DISCLAIMER NOTICE

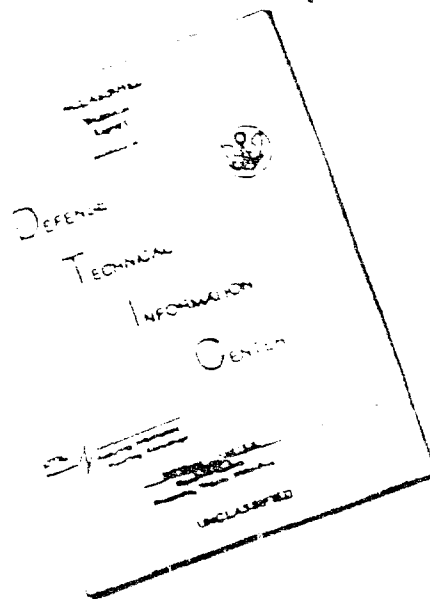

THIS DOCUMENT IS BEST
QUALITY AVAILABLE. THE COPY
FURNISHED TO DTIC CONTAINED
A SIGNIFICANT NUMBER OF
PAGES WHICH DO NOT
REPRODUCE LEGIBLY.

REPRODUCED FROM
BEST AVAILABLE COPY

THIS DOCUMENT CONTAINED
BLANK PAGES THAT HAVE
BEEN DELETED

**Destroy this report when no longer needed.
Do not return it to the originator.**

**The findings in this report are not to be construed as an official Department
of the Army position unless so designated by other authorized documents.**

**Use of trade names in this report does not constitute an official endorsement
or approval of the use of such commercial products.**



| REPORT DOCUMENTATION PAGE | | READ INSTRUCTIONS BEFORE COMPLETING FORM |
|---|---|---|
| 1. REPORT NUMBER Technical Memorandum 10-84 | 2. GOVT ACCESSION NO. AD-A145240 | 3. RECIPIENT'S CATALOG NUMBER |
| 4. TITLE (and Subtitle) DEVELOPMENT OF ADVANCED TECHNOLOGY FOR QUIET VEHICLES EXPERIMENTAL QUIET ROADARM DESIGN | 5. TYPE OF REPORT & PERIOD COVERED Final | |
| | 6. PERFORMING ORG. REPORT NUMBER | |
| 7. AUTHOR(s) Jerome A. Schmiedeberg Georges R. Garinther Karl G. Turner Thomas R. Norris | 8. CONTRACT OR GRANT NUMBER(s) | |
| 9. PERFORMING ORGANIZATION NAME AND ADDRESS | 10. PROGRAM ELEMENT, PROJECT, TASK AREA & WORK UNIT NUMBERS AMCMS Code 691000 | |
| 11. CONTROLLING OFFICE NAME AND ADDRESS US Army Human Engineering Laboratory Aberdeen Proving Ground, Maryland 21005-5001 | 12. REPORT DATE July 1984 | |
| | 13. NUMBER OF PAGES 62 | |
| 14. MONITORING AGENCY NAME & ADDRESS (if different from Controlling Office) | 15. SECURITY CLASS. (of this report) Unclassified | |
| | 15a. DECLASSIFICATION/DOWNGRADING SCHEDULE | |
| 16. DISTRIBUTION STATEMENT (of this Report) Approved for public release; distribution unlimited. | | |
| 17. DISTRIBUTION STATEMENT (of the abstract entered in Block 20, if different from Report) | | |
| 18. SUPPLEMENTARY NOTES | | |
| 19. KEY WORDS (Continue on reverse side if necessary and identify by block number) | | |
| Tracked Vehicles | Track and Suspension | |
| Noise Reduction | Hearing Loss | |
| Mechanical Impedance Measurement | Speech Communication | |
| Noise Sources | | |
| 20. ABSTRACT (Continue on reverse side if necessary and identify by block number) | | |
| <p>> Noise produced by track-laying vehicles causes hearing loss, interferes with speech communication and provides aural detectability to the enemy. The purpose of this program is to develop noise reduction concepts and to develop the technology necessary to produce a lightweight, track-laying vehicle of the M113 family that has a sound pressure level of 100 dB(A). --> C. L. F. 1</p> | | |

The earlier phases of this study rank ordered the major noise sources of the M113A1 armored Personnel Carrier, developed a preliminary mathematical model of the track and suspension, developed a high compliance prototype idler that provides over 15 dB(A) of idler dependent noise reduction, and developed an experimental compliant sprocket. Initial work was done to allow analytical prediction of changes in interior noise due to hull structure changes.

The present study developed an experimental isolated roadarm assembly. The goal of 95 dB(A) for roadarm-induced noise alone was closely approached. Noise-to-force transfer function measurements were made on this assembly mounted in an M113A1.

| | |
|-------------------|-------------------------------------|
| Accession For | |
| NTIS GNDI | <input checked="" type="checkbox"/> |
| ERIC TAB | <input type="checkbox"/> |
| Other Agency | <input type="checkbox"/> |
| Justification | |
| By | |
| Date | |
| Availability Code | |
| Annotation | |
| Dist | Special |

A/1

DEVELOPMENT OF ADVANCED TECHNOLOGY FOR QUIET VEHICLES
EXPERIMENTAL QUIET ROADARM DESIGN

Jerome A. Schmiedeberg
Karl G. Turner
Thomas R. Norris
Georges R. Garinther

July 1984

APPROVED:

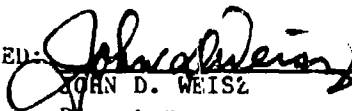

JOHN D. WEISZ
Director

US Army Human Engineering Laboratory

US ARMY HUMAN ENGINEERING LABORATORY
Aberdeen Proving Ground, Maryland 21005-5001

Approved for public release;
distribution unlimited.

PREFACE

The US Army Human Engineering Laboratory greatly appreciates the encouragement and funding provided by the US Army Tank-Automotive Command. The quiet track-laying vehicle program would not have been possible without the effort of Don Rees and Dennis Sweers of that organization.

TABLE OF CONTENTS

| | <u>Page</u> |
|---|-------------|
| EXECUTIVE SUMMARY..... | 1 |
| 1. INTRODUCTION..... | 2 |
| 2. BACKGROUND AND NOISE REDUCTION GOALS..... | 2 |
| 2.1 Interior Noise in Tracked Vehicles General Discussion..... | 2 |
| 2.2 Selection of the M113A1 as the Test Vehicle..... | 4 |
| 2.3 Interior Noise Levels in the M113A1..... | 4 |
| 2.4 Roadarm Noise Measurements and Development of Noise Reduction Goals..... | 4 |
| 2.5 Noise Reduction Goal for Roadarms..... | 10 |
| 3. DESIGN OF AN EXPERIMENTAL ROADARM..... | 14 |
| 3.1 Design Concepts..... | 14 |
| 3.2 Design Goals..... | 14 |
| 3.2.1 Compliant Roadwheel Rim..... | 15 |
| 3.2.2 Lower Side Plate Isolation..... | 18 |
| 3.2.3 Isolated Chassis..... | 18 |
| 3.2.4 Isolated Roadarm..... | 20 |
| 3.3 Design Considerations of Roadarm Isolator..... | 20 |
| 4. TEST PROCEDURES..... | 24 |
| 4.1 Identification of Roadarm Vibration Energy Paths..... | 24 |
| 4.2 Mathematical Basis for Noise Reduction Predictions..... | 26 |
| 4.3 Measurement Procedures for Mobilities and Noise-to- Force Ratios..... | 28 |
| 4.4 Test Procedures for Roadarm Mount Evaluation..... | 34 |
| 5. TEST RESULTS..... | 40 |
| 5.1 Interior Noise Test Results..... | 40 |
| 5.2 Exterior Noise (Acoustic Signature)..... | 45 |
| 6. INTERPRETATION AND ASSESSMENT OF NOISE REDUCTION DATA..... | 45 |
| 6.1 Interior Noise Reduction..... | 45 |
| 6.2 Acoustic Signature (Exterior Noise) Reduction..... | 45 |
| 7. CONCLUSIONS AND RECOMMENDATIONS..... | 48 |
| REFERENCES..... | 51 |
| Appendix A - Previous Noise Reduction Studies..... | 52 |
| Appendix B - Roadarm Noise-To-Force Transfer Function Data..... | 55 |

FIGURES

| | <u>Page</u> |
|---|-------------|
| 2.1 Schematic Diagram of Sources and Paths Responsible for Interior Noise in Tracked Vehicles..... | 3 |
| 2.2 Vibration Generated by the Roadwheel | 5 |
| 2.3 Noise Source Spectra at 15 mph at Center of Crew Compartment..... | 6 |
| 2.4 Noise Source Spectra at 25 mph at Center of Crew Compartment..... | 6 |
| 2.5 Noise Source Spectra at 32 mph at Center of Crew Compartment..... | 7 |
| 2.6 Track System Source Contributions to M113A1 Crew Area Noise Levels at Various Speeds..... | 7 |
| 2.7 Speed Dependence of Production M113A1 Noise at the Crew Position Operating on Paved Track..... | 8 |
| 2.8 Speed Dependence of Production M113A1 Noise at the Driver Position Operating on Paved Track..... | 9 |
| 2.9 Vehicle in Roadwheels-Only Test Configuration..... | 11 |
| 2.10 Speed Dependence of Roadwheel - Induced Noise at Crew Position..... | 12 |
| 2.11 Speed Dependence of Roadwheel - Induced Noise at Driver Position..... | 12 |
| 2.12 M113A1 Roadwheel Generated Noise in the Crew Area at a Vehicle Speed of 25 mph..... | 13 |
| 3.1 Calculated Isolator Efficiency for a Compliant Roadwheel..... | 17 |
| 3.2 Isolated Lower Side Plate Concept..... | 19 |
| 3.3 Isolated Roadarm Concept..... | 21 |
| 3.4 Roadarm Isolator Efficiency Calculated for Various Isolator Spring Rates in the Vertical Direction..... | 22 |
| 3.5 Roadarm Isolator Efficiency Calculated for Various Isolator Spring Rates in the Transverse Direction..... | 23 |

FIGURES

| | | <u>Page</u> |
|------|--|-------------|
| 3.6 | Experimental Roadarm Mounted on M113A1 Vehicle S/N SJ 136 ... | 25 |
| 4.1 | Simplified Model of an Isolated Roadarm..... | 27 |
| 4.2 | Instrumentation Setup for Mechanical Mobility Measurements... | 29 |
| 4.3 | M113A1 Roadarm Mobility without Roadwheels Attached..... | 31 |
| 4.4 | M113A1 Roadarm Mobility with Both Roadwheels Attached..... | 32 |
| 4.5 | M113 Hull Mobilities at 250 Hertz Relative to the Bottom Corner..... | 33 |
| 4.6 | M113 Hull Noise-to-Force Transfer Functions at 250 Hertz Relative to the Bottom Corner..... | 35 |
| 4.7 | M113 Hull Noise-to-Force Measurements at the Bottom Outside Corner of the Box Beam with the Force Input Vertically..... | 36 |
| 4.8 | Experimental Roadarm Test Setup, Force Input in the Vertical Direction..... | 38 |
| 4.9 | Experimental Roadarm Test Setup, Force Input in the Transverse Direction..... | 39 |
| 4.10 | Instrumentation Diagram for Roadarm Noise Tests, Force Input in the Transverse Direction | 41 |
| 4.11 | Instrumentation Diagram for Roadarm Noise Tests, Force Input in the Vertical Direction | 42 |
| 5.1 | Noise-to-Force Transfer Function with the Force Input in the Vertical Direction..... | 43 |
| 5.2 | Noise-to-Force Transfer Function with the Force Input in the Transverse Direction..... | 44 |
| 5.3 | Insertion Loss at the Experimental Isolated Roadarm..... | 46 |
| 6.1 | Estimated Exterior Signature Spectra of M113 with Ten Standard Roadarms, Experimental Compliant Roadarms, and M113A1 Exhaust at 25 Feet to the Left of the Hull..... | |

TABLES

| | <u>Page</u> |
|--|-------------|
| 2.1 Calculation of One-Third Octave Band Roadwheel Noise Reduction Goals Which Would Achieve Category B of MIL-STD-1474B for M113 Crew Area Noise at a Vehicle Speed of 30 mph..... | 14 |
| 6.1 Calculation of Estimated Octave Band Hull-Radiated Acoustic Signature for M113 Roadarm - Induced Noise at 25 Feet to Side for Experimental Compliant and Standard Roadarms at 10 to 20 Miles per Hour..... | 47 |

EXECUTIVE SUMMARY

Noise of track-laying vehicles has historically been a problem which interferes with speech communication, produces hearing loss, damages sensitive vehicle-mounted components, and permits aural detectability at great distances. Prior studies have determined that the dominant sources producing interior noise [4] are the idlers, the sprockets, and the roadwheels, with the engine being a secondary source. The dominant source for external vehicle signature [12] is the exhaust, with the suspension being a secondary source.

The purpose of this study was to design, fabricate and determine the noise reduction provided by an experimental low-noise roadwheel/roadarm. A prototype idler and an experimental sprocket have been fabricated which provide 15 and 8 dB noise reduction, respectively [4,6].

Mobility measurements and noise-to-force transfer ratios were made on the hull, roadarm, and roadwheel to identify vibrational energy paths from the roadwheel to the vehicle interior and to aid in determining the optimum location for the isolation mounts. Mount attachment must be at positions which provide the greatest stiffness to provide maximum noise reduction. These measurements were also used to estimate the noise reduction which would be obtained by various isolation concepts.

The low-noise roadarm system consists of a pair of rubber isolators placed between the roadarm and the hull, a steel tube encircling the torsion bar, and an isolator at the far end of the torsion bar. This system isolates the entire roadwheel/roadarm system from the hull and transfers twisting moments of the roadwheel to the far side of the hull where they are reduced in magnitude. The rubber isolators have adequate structural integrity and will withstand several times the force that would crush or buckle the attached roadwheel.

Noise reduction produced by this isolated roadarm design was determined by obtaining the difference in interior noise-to-force ratio between the standard roadwheel/roadarm and the low noise system. Roadwheel noise reduction achieved by this system was 22 dB at the critical frequency of 250 Hz which effectively meets most, but not all, of its goals of being quiet, practical and durable.

This reduction of roadwheel noise, when combined with reduced idler and sprocket noise, will permit overall vehicle noise to approach the limits of MIL-STD-1474; total suspension system noise reduction when combined with a low-noise exhaust system will reduce aural detectability distance. In addition, the vehicle would have much lower vibration levels, which will reduce vibration-induced stresses on sensitive components.

The present low-noise roadwheel/roadarm is an experimental design which has proven the concept that isolation of the roadwheel/roadarm provides noise reduction approaching the desired goal. A future effort will refine this concept by providing greater compliance while maintaining load capacity, improving practicality, maintaining economy of manufacture, possibly providing direct interchangeability for existing vehicles, and incorporating a water seal.

1. INTRODUCTION

This study was conducted by the FMC Corporation under the joint sponsorship of the US Army Human Engineering Laboratory (HEL) and the US Army Tank-Automotive Command (TACOM) as part of the ongoing effort to achieve significant noise reduction in tracked vehicles. (For a list of previous studies, see Appendix A.) Reduction of the interior noise level to noise limits given in MIL-STD-1474B, Category B, would allow crewmembers to operate without wearing earplugs (in addition to helmets) and improve communications between them. Reduction of externally emitted noise could reduce the distance at which the vehicle would be audible. The present study particularly addresses the control of suspension-induced noise from the roadarms and presents an experimental design to this end.

The overall goal of the program is to develop the technology necessary to reduce the interior noise of a lightweight tracked vehicle to 100 dB(A) at 30 mph. Initially, the program identified dominant and secondary noise sources. Three dominant noise sources, the idler wheels, sprockets, and roadwheels are approximately equal in magnitude. The total roadwheel contribution to the overall noise level must be limited to 95 dB(A), as must the contributions of the sprocket and the idler, to achieve interior noise level of 100dB(A).

Reducing roadwheel noise is the focus of the present study. The acoustic energy input mechanisms from roadwheel-induced vibratory forces were determined. Four noise reduction design concepts were evaluated, and one was chosen for fabrication and testing. Substantial noise reduction was achieved; however, the estimated A-weighted noise of the experimental roadarm exceeded the design goal of 95 dB(A) by 5 dB.

2. BACKGROUND AND NOISE REDUCTION GOALS

2.1 Interior Noise in Tracked Vehicles - General Discussion

A schematic representation, Figure 2.1, shows the major vibration sources and paths in a typical tracked vehicle. Most interior noise in tracked vehicles originates from the track interaction with the drive sprockets, idler wheels, and roadwheels. The engine and power train are typically secondary noise sources. Specifically, in the M113 vehicle, the sprockets, idler wheels, and roadwheels contribute noise of approximately equal loudness at 30 mph; all other sources contribute much less acoustic energy.

During vehicle operation, the suspension and engine/power train components transmit significant levels of vibration energy to the hull. Because the entire hull surface vibrates (and radiates noise), the interior noise levels consist of both direct and reflected sound. Previous theoretical and practical studies have shown that the interior noise cannot be appreciably reduced by acoustic barriers or noise absorptive materials (see Appendix A).

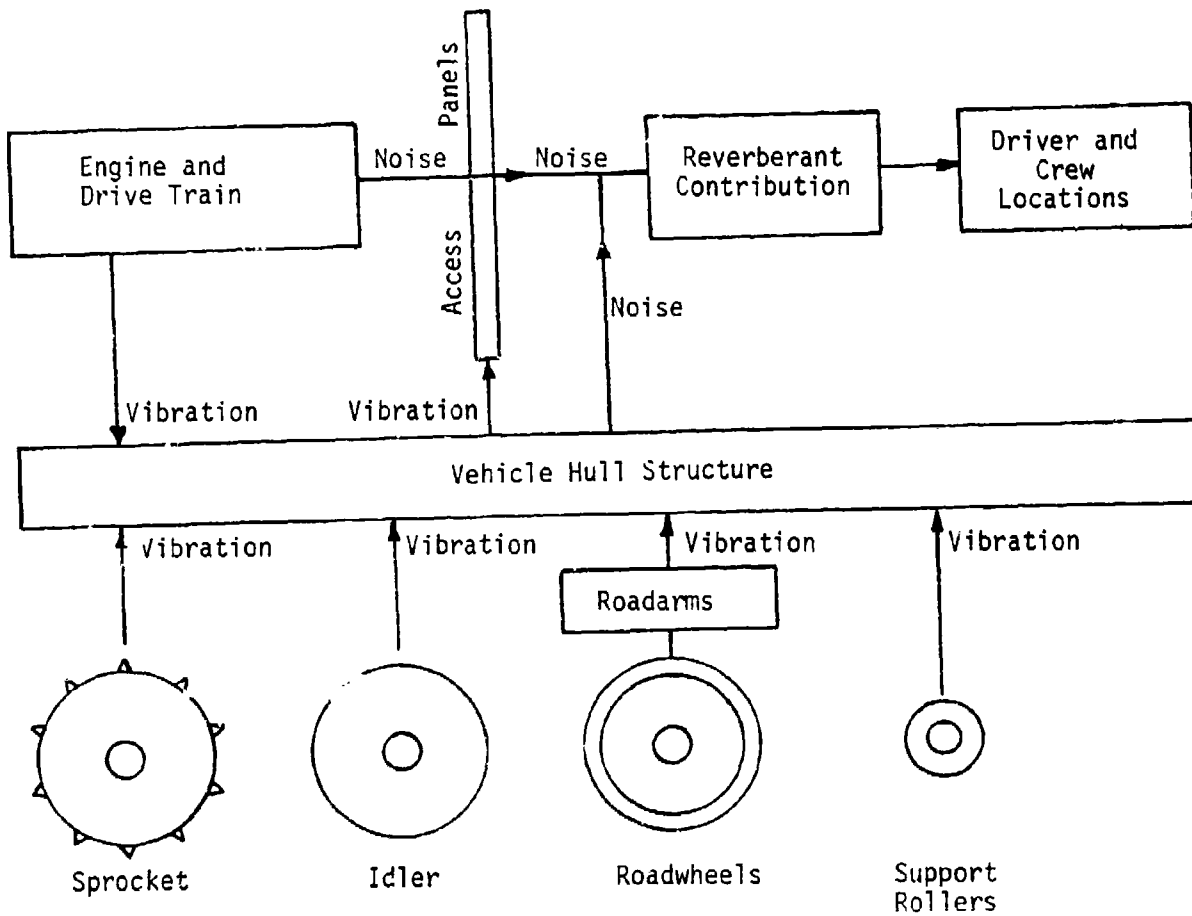

Figure 2.1 Schematic Diagram of Sources and Paths Responsible for Interior Noise in Tracked Vehicles.

Thus, the only remaining noise control option is the isolation of the noise and vibration sources themselves. To do this, the energy paths between the sources and the hull need to be determined and modified.

The roadwheel-generated noise is created by the vibration caused by the roadwheels rolling over the rough inner surface of the track. As the roadwheels pass over the pinned connections of the trackshoes, the trackshoes tend to tip, causing the roadwheels to impact the trackshoes (see Figure 2.2). Idler and sprocket wheel vibration are caused by chordal action between the trackshoes and the idler and sprocket wheels [4]. Referring to Figure 2.1, the interconnected nature of the suspension vibration and interior noise is evident.

2.2 Selection of the M113A1 as the Test Vehicle

The M113A1 was chosen as the test vehicle for this study. Its advantages are that it is currently in production, is widely distributed, shares many features in common with other larger vehicles, and parts are readily available. Numerous noise measurements of the M113A1 have been taken in previous studies, so its acoustic characteristics are well-documented [4]. Noise reduction concepts from this study may be applicable to other tracked vehicles containing similar design features.

2.3 Interior Noise Levels in the M113A1

When the M113A1 is moving, noise levels in the crew and driver's area exceed comfort, communication, and hearing conservation standards. More specifically, they exceed the limits specified in MIL-STD-1474B, Category B. This standard provides maximum allowable levels for systems requiring electrically aided communication and noise-attenuating helmets or headsets. The octave band spectra of the M113A1 at 15, 25, and 32 mph are shown in Figures 2.3, 2.4, and 2.5 [4], respectively. The relative contributions of the idlers, sprockets, and roadwheels are shown in Figure 2.6 [4]. The dependence of A-weighted and octave band noise levels on speed is shown in Figures 2.7 and 2.8 [4] at the crew and driver's positions, respectively.

2.4 Roadarm Noise Measurements and Development of Noise Reduction Goals

In previous investigations the roadarms were shown to transmit significant vibration energy from the roadwheels to the hull [4]. By vibration isolation techniques, this energy path could be partially blocked, thus reducing the interior noise level.

During the first vehicle noise study sponsored by HEL [4], the contribution of the roadwheels to interior vehicle noise was measured. To isolate the roadwheel noise contribution, it was necessary to eliminate other noise sources by removing the idler wheel assemblies, track tension adjusters, shock absorbers, and final drives. The track was shortened by removing an appropriate number of shoes, and vehicle weight was allowed

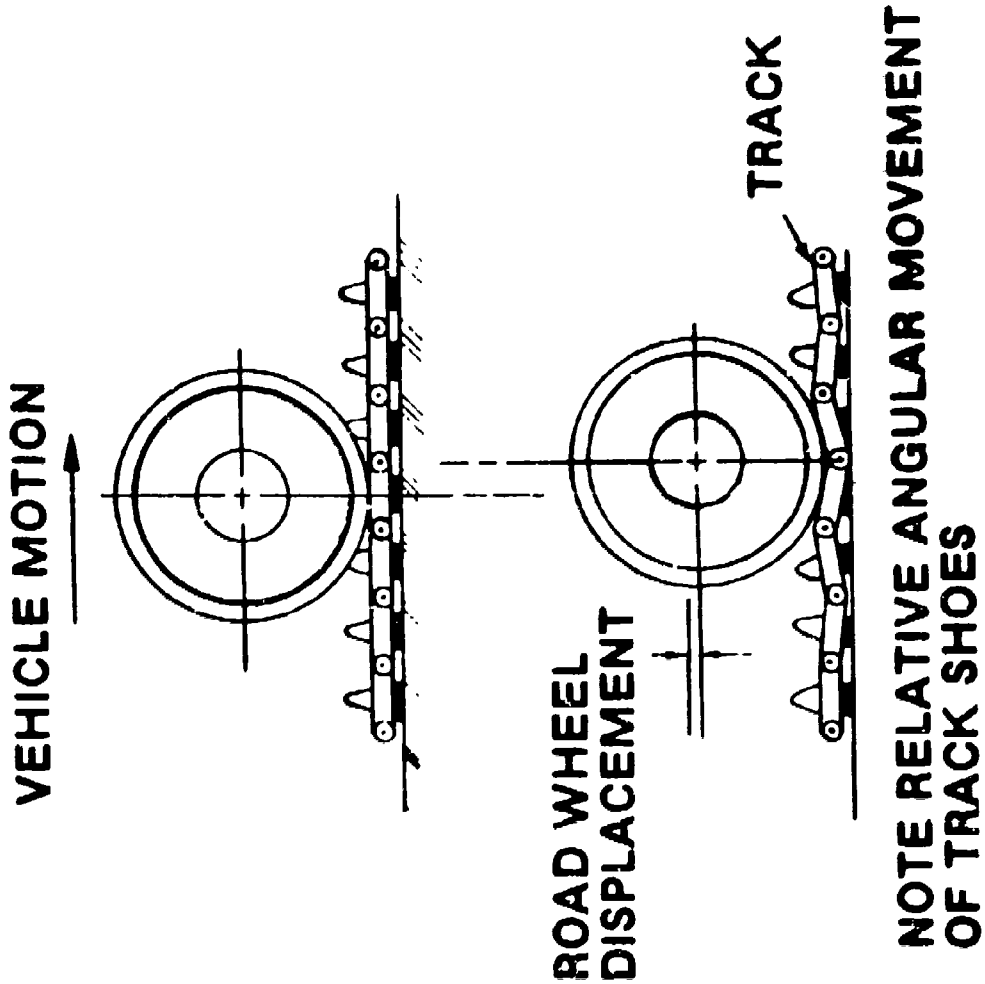

Figure 2.2 Vibration Generated by the Roadwheel

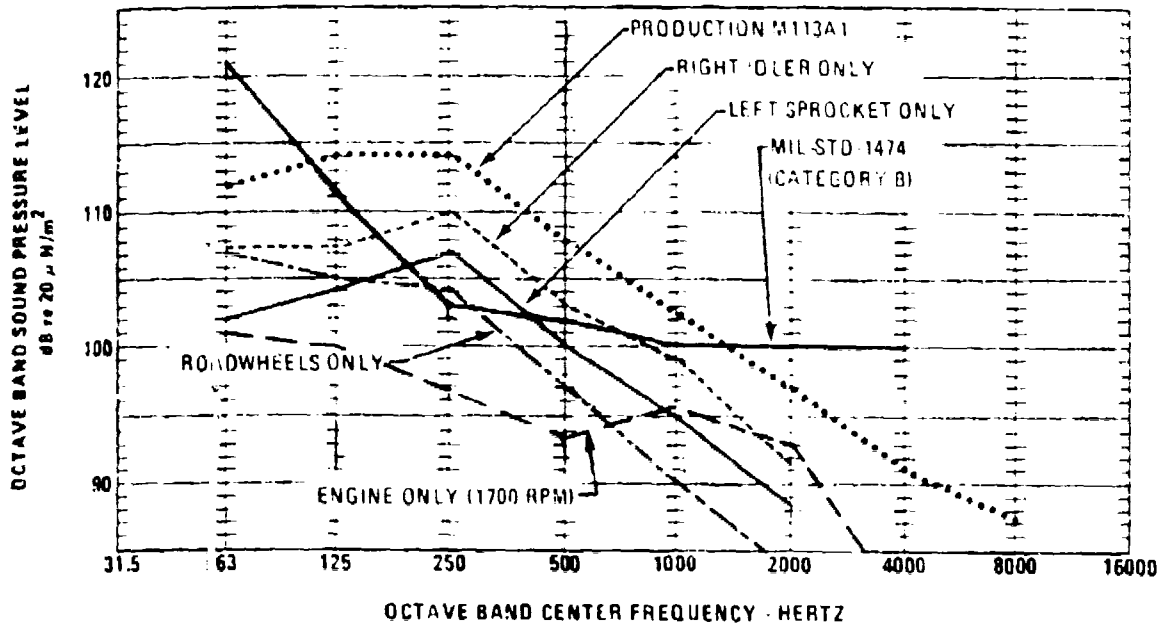

Figure 2.3 Noise Source Spectra at 15 mph at Center of Crew Compartment

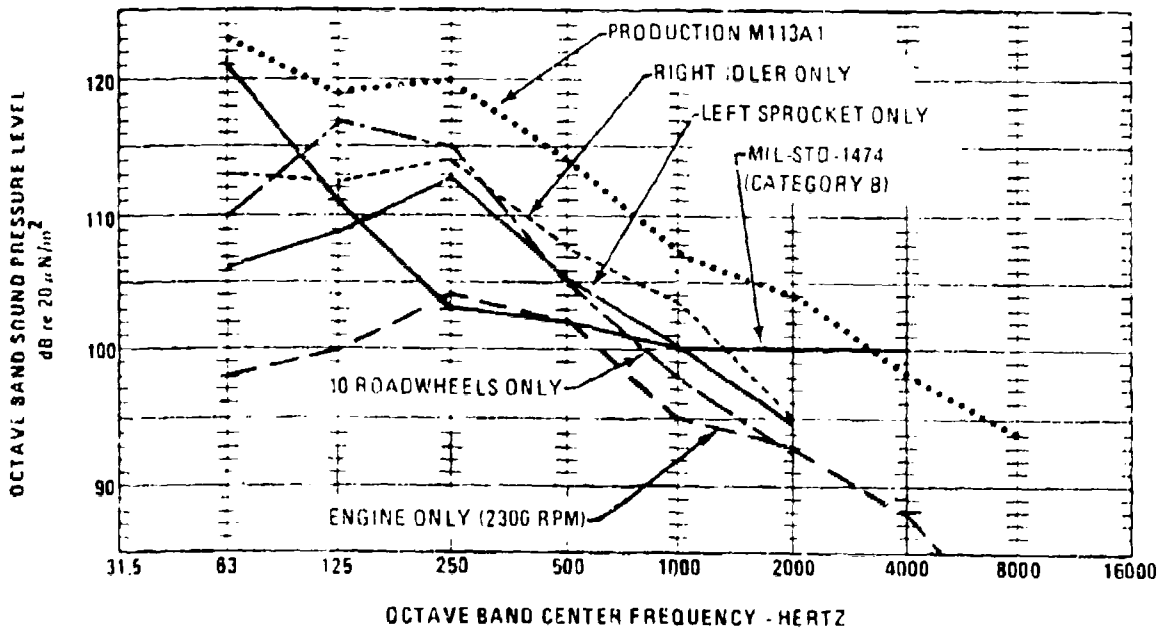

Figure 2.4 Noise Source Spectra at 25 mph at Center of Crew Compartment

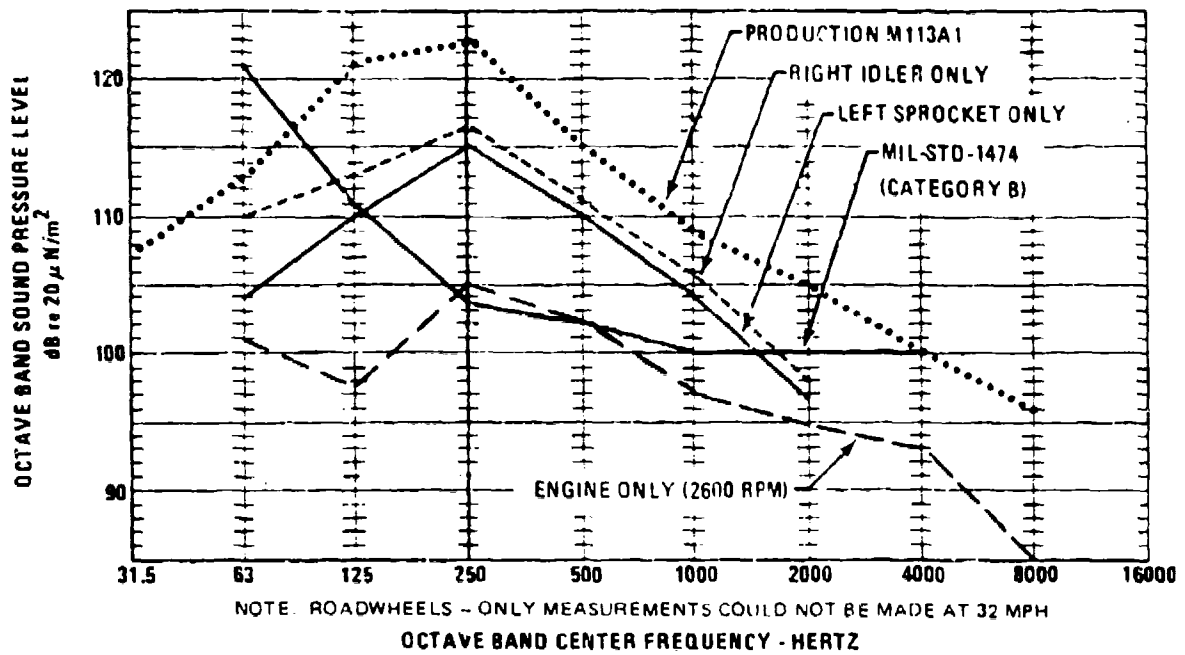

Figure 2.5 Noise Source Spectra at 32 mph at Center of Crew Compartment

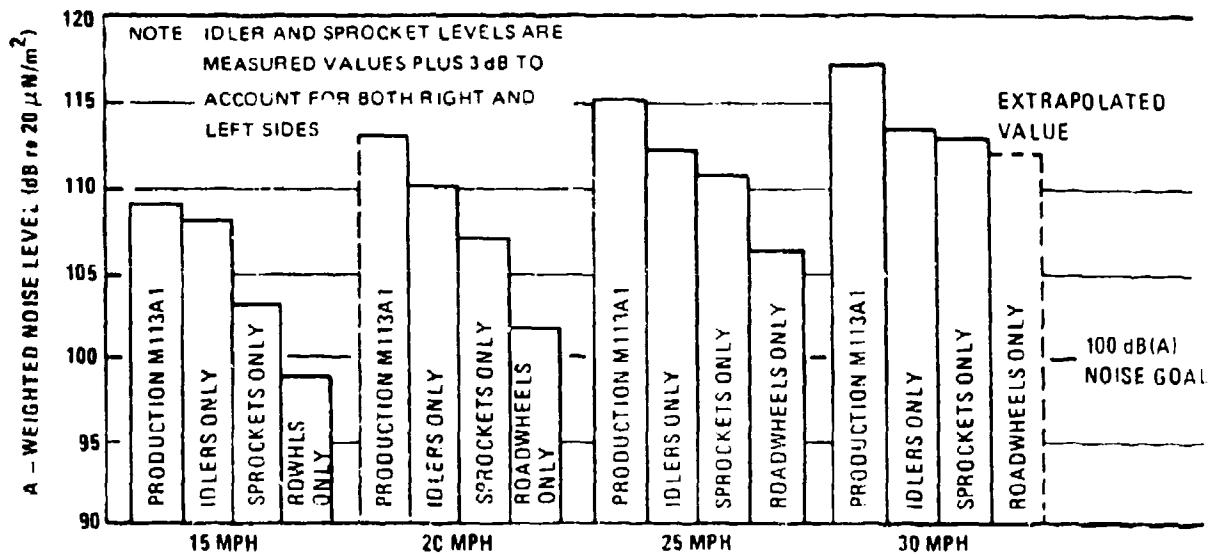

Figure 2.6 Track System Source Contributions to M113A1 Crew Area Noise Levels at Various Speeds.

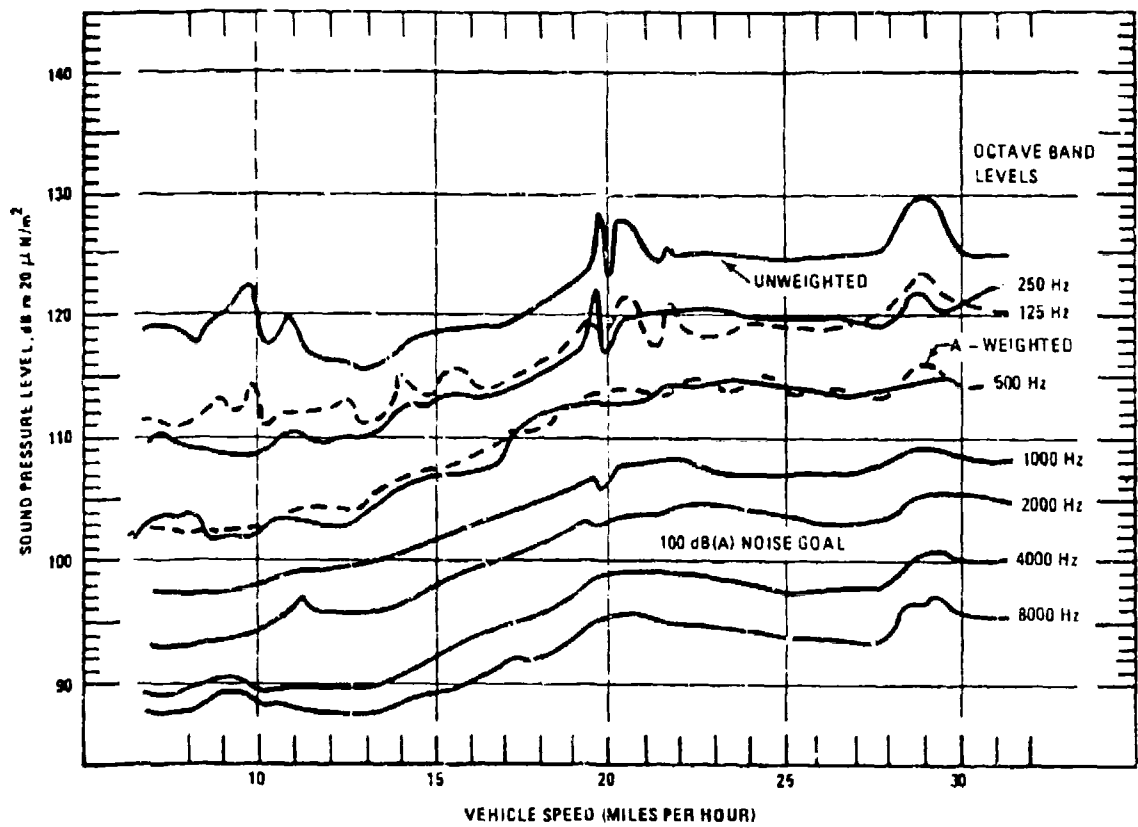

Figure 2.7 Speed Dependence of Production M113A1 Noise at the Crew Position Operating on Paved Track.

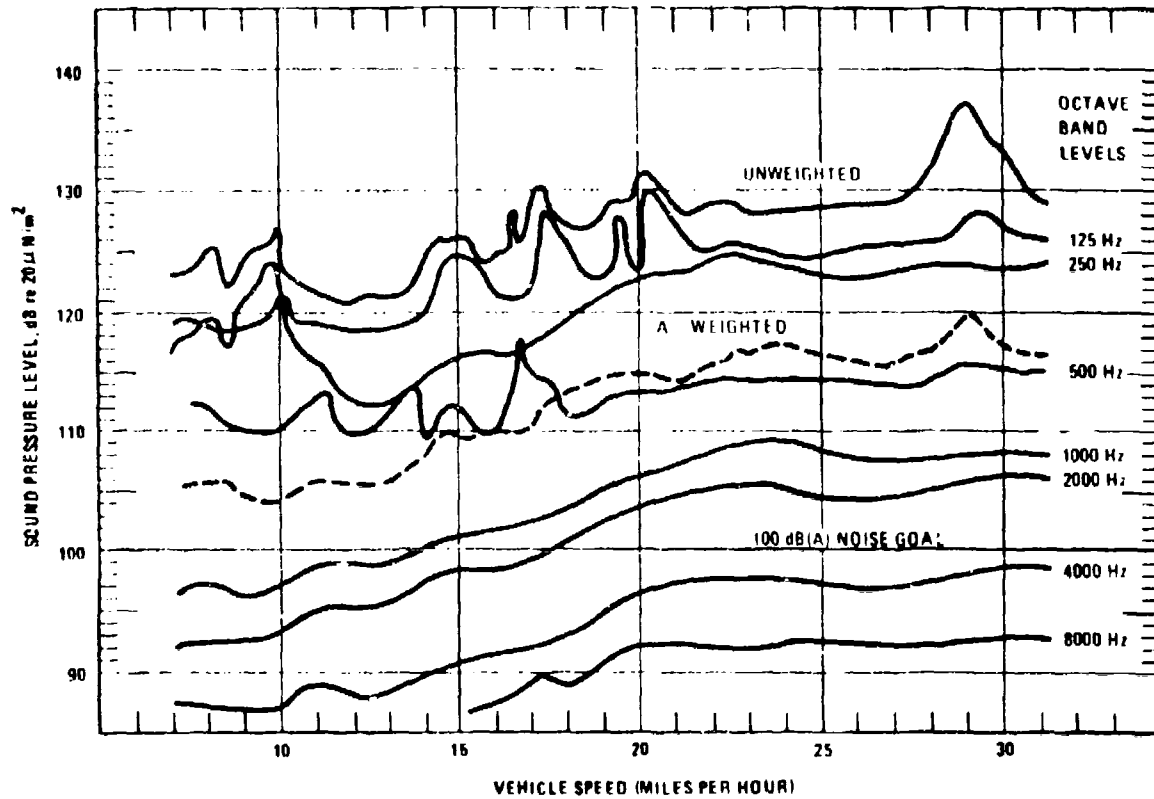

Figure 2.8 Speed Dependence of Production M113A1 Noise at the Driver Position Operating on Paved Track.

to tension the track. Because of interference between the track and the torsion-bar end of the roadarm, the No. 1 roadarm was installed in a leading, rather than in its usual trailing, position. The vehicle was then towed around a test track and the interior noise levels were measured. Figure 2.9 shows the vehicle in its roadwheel noise test configuration.

There was concern that modifications in track tension and track entry angle to the leading roadwheel would distort the results of the roadwheel noise tests. However, based on roadarm acceleration data, these roadwheels-only measurements appear to be valid estimates of normal roadwheel noise.

Figures 2.10 and 2.11 [4] show the contribution of the roadwheels to the noise at the crew and driver positions measured during the roadwheels-only noise test. Since the maximum vehicle speed attainable during the roadwheels-only noise measurement was 25 mph, a straight-line extrapolation of the curves between 22 mph and 25 mph in Figures 2.10 and 2.11 was used to obtain an estimate of the roadwheel contribution at 30 mph. The extrapolation indicates that the noise level would be between 111 and 115 dB(A) in the crew area and between 112 and 114 dB(A) in the driver's position depending on how much of the A-weighted curve is used for the extrapolation. An average estimated roadwheels-only noise level of 113 dB(A) at 30 mph is essentially as high as that due to a single idler or sprocket.

2.5 Noise Reduction Goal for Roadarms

To develop a vehicle with an overall interior noise level of 100 dB(A) at 30 mph, total roadwheel-generated noise must be reduced to 95 dB(A)-a substantial noise reduction of 18 dB(A). At lower speeds, the roadwheel noise is much less than that of the idler or sprocket, as shown in Figure 2.5. At 15 mph, the required noise reduction is only 4 dB(A).

The 1/3-octave band noise reduction goals were calculated by taking the roadarm noise spectrum shown on Figure 2.12 for a vehicle speed of 25 mph, and adding 3 dB to obtain the estimated 1/3-octave band spectrum at 30 mph. From this estimated spectrum the 1/3-octave band roadwheel noise goal spectrum (also shown on Figure 2.12) was subtracted to obtain the 1/3-octave band roadwheel noise reduction goals. These calculations are shown in Table 2.1.

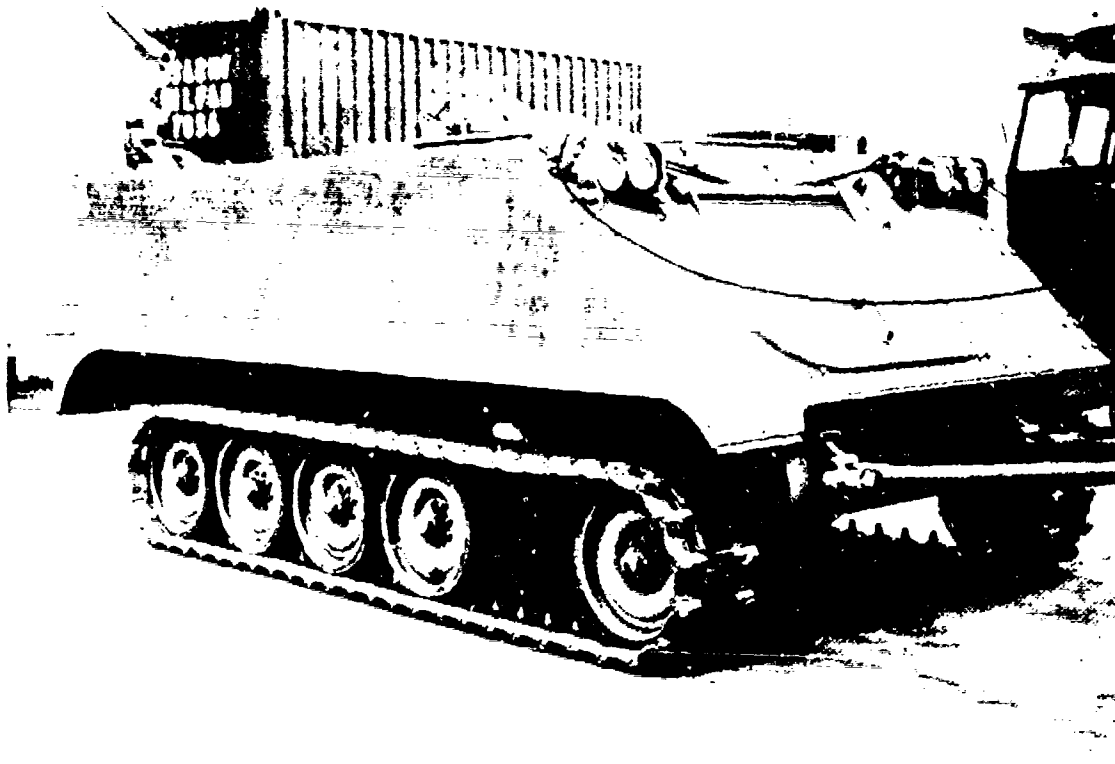

Figure 2.9 Vehicle in Roadwheels-Only Test Configuration

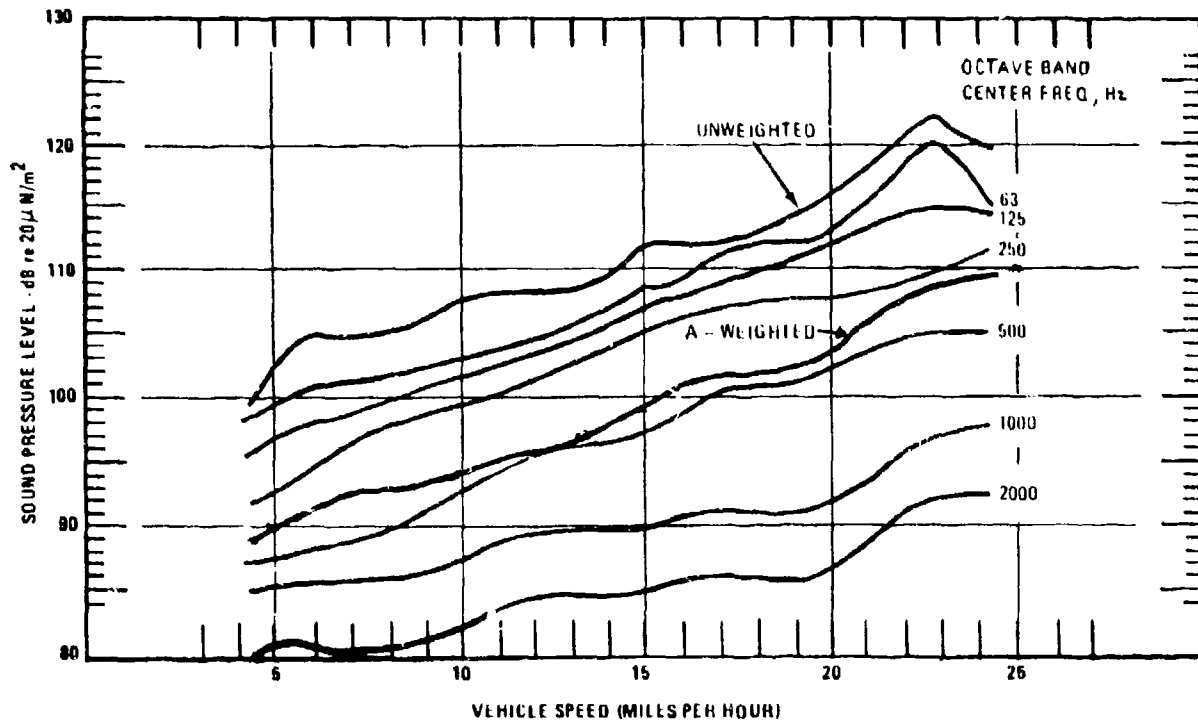

Figure 2.10 Speed Dependence of Roadwheel-Induced Noise at Crew Position

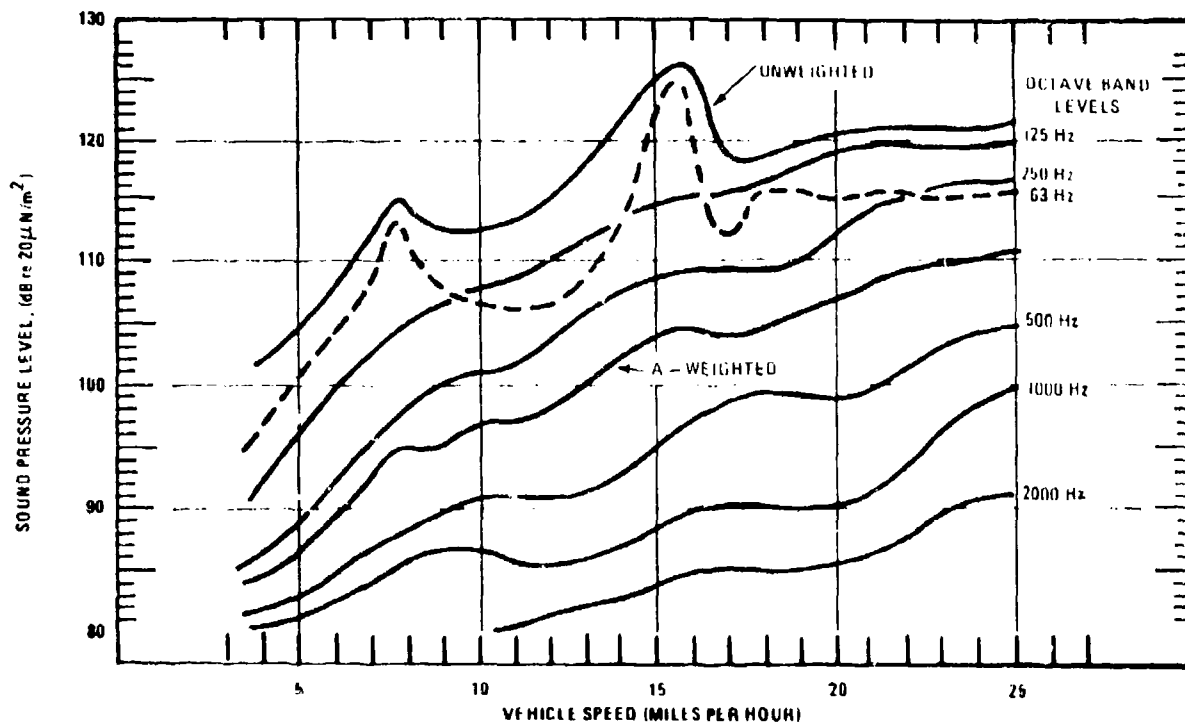
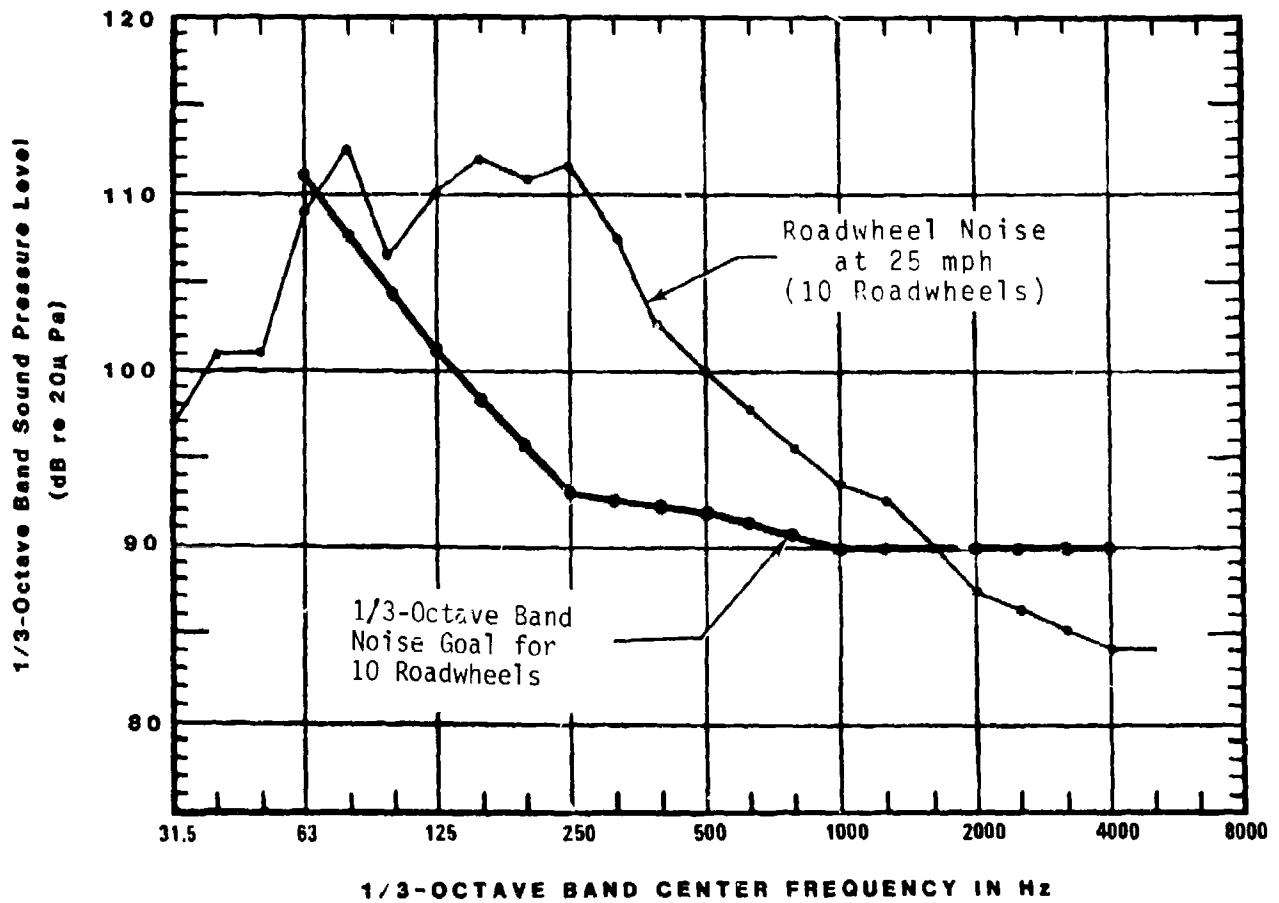

Figure 2.11 Speed Dependence of Roadwheel-Induced Noise at Driver Position



| | | | | | | | | | |
|---|---------------------------------------|-----|-----|-----|-----|-----|-----|-----|-----|
| Standard Roadwheel Noise Spectrum at 25 mph | 110 | 112 | 111 | 112 | 107 | 103 | 100 | 98 | 95 |
| Estimated Roadwheel Noise Spectrum at 30 mph | 113 | 115 | 114 | 115 | 110 | 106 | 103 | 101 | 98 |
| Roadwheels-Only Noise Spectrum Goal 1/3-Octave Band | 101 | 98 | 95 | 93 | 93 | 92 | 92 | 91 | 90 |
| Noise Reduction Goal For Roadwheels | 12 | 17 | 18 | 22 | 17 | 14 | 11 | 10 | 8 |
| (All Values are dB re 20 μ Pa) | 125 | 160 | 200 | 250 | 315 | 400 | 500 | 630 | 800 |
| | 1/3-Octave Band Center Frequency (Hz) | | | | | | | | |

Table 2.1 Calculation of 1/3-Octave Band Roadwheel Noise Reduction Goals Which Would Achieve Category B of MIL-STD-1474B for M113 Crew Area Noise at a Vehicle Speed of 30 mph.

3. DESIGN OF AN EXPERIMENTAL ROADARM

Four concepts were considered for the experimental quiet roadarm design. Each concept was accepted or rejected based on its effectiveness in reducing noise-generating forces and its practicality. These four design concepts are discussed in the following sections along with the design goals and mechanical design criteria.

3.1 Design Concepts

Four engineering design concepts were considered in developing the experimental noise controls:

- (1) Compliant roadwheel rim or tire
- (2) Add-on exterior lower side plate or frame
- (3) Isolated chassis
- (4) Isolated roadarm

3.2 Design Goals

The design goals for the experimental roadarm are:

- o To reduce interior noise level in the M113A1 to 95 dB(A) or less for 10 roadarms combined (roadwheel-only component, excludes noise from idler and sprocket wheels).

- o To develop a sufficiently durable roadarm to withstand normal vehicle loads and stresses imposed during testing.
- o To provide simplicity and economy of manufacture.
- o To reduce exterior noise to lessen aural detection distance.

The design criteria that evolved from these goals were used to guide design decisions. Testing was designed with the following in mind:

- o Hull modification should be minimized.
- o Existing hardware should be used wherever possible.
- o The average static load on each roadwheel during testing should be 10% of the total vehicle weight, or 2,500 lbs, in the vertical direction.
- o The maximum dynamic loads on the roadwheel are assumed to be 7,000 lbs in the vertical direction and 5,000 lbs at the roadwheel rim in the transverse direction. (This approximates the largest forces encountered when moving over rough terrain.)
- o The nominal shear stresses on rubber compliant elements should be restricted to a recommended value of 60 psi except for transient conditions or where preloading greatly reduces rubber fatigue [8].

3.2.1 Compliant Roadwheel Rim

The compliant roadwheel concept employs a springy tire to absorb shock and vibration. This concept is similar to a pneumatic tire on an automobile, except that the tracked vehicle tire would probably be solid to maintain combat effectiveness.

Advantages

The advantages of the compliant roadwheel rim concept are that:

- o This is a bolt-in design. An existing roadwheel is simply removed and a compliant rim roadwheel installed.
- o There are no hidden parts to fail.
- o The design can be made mechanically very simple.
- o There is possibly little or no weight penalty.
- o The noise reduction occurs at the source so that noise emitted from the track and roadwheel disks is reduced, as well as hull-emitted noise.

- o If it were possible to use a partially pneumatic, partially solid tire, track block tipping might be reduced and resistance to propulsion (drag) may be reduced with consequent fuel savings and performance increase.

Disadvantages

The disadvantages of the compliant roadwheel rim concept are:

- o Cost may be high because there are 20 wheel halves per vehicle.
- o If there is a weight increase, it would be multiplied by 20.
- o In order to be acoustically effective, the tire would have to be rather soft, which may lead to thermal problems.
- o The durability may be inadequate, and would be very difficult to assess without extensive and time-consuming testing of a prototype tire.
- o If a partly pneumatic tire were adopted, it would need a run-flat, "get-home" capability.

The effectiveness of the compliant tire concept may be estimated using a vibration isolator model. The imaginary "isolator" would be between the track and the roadwheel's metal disk. Using the measured mobilities of the wheel disk and rubber tire and the methods discussed in Section 4.2 of this report, the noise reduction may be calculated. Calculations for a variety of roadwheel compliances are shown on Figure 3.1. These noise reductions are relative to the existing hard rubber tire. It may be seen that, theoretically, the compliant tire will produce useful noise reduction. For a compliance of approximately 3,000 lbs/inch, or softer, the minimum noise reduction goal of 20 dB in the 250 Hz octave band is estimated to be achieved.

The model used to estimate noise reduction of the compliant roadwheel has inherent uncertainties that may be misleading. The advantages and disadvantages of the model are discussed next.

The advantages of the model include:

- o All vibration dynamics of the wheel disk and roadarm are included in the model.
- o The model is very flexible because the insertion loss can be digitally calculated for a tire with various values of compliance and damping.
- o Proposed changes in the track or roadwheel disk can be quickly evaluated, using a digital computer.

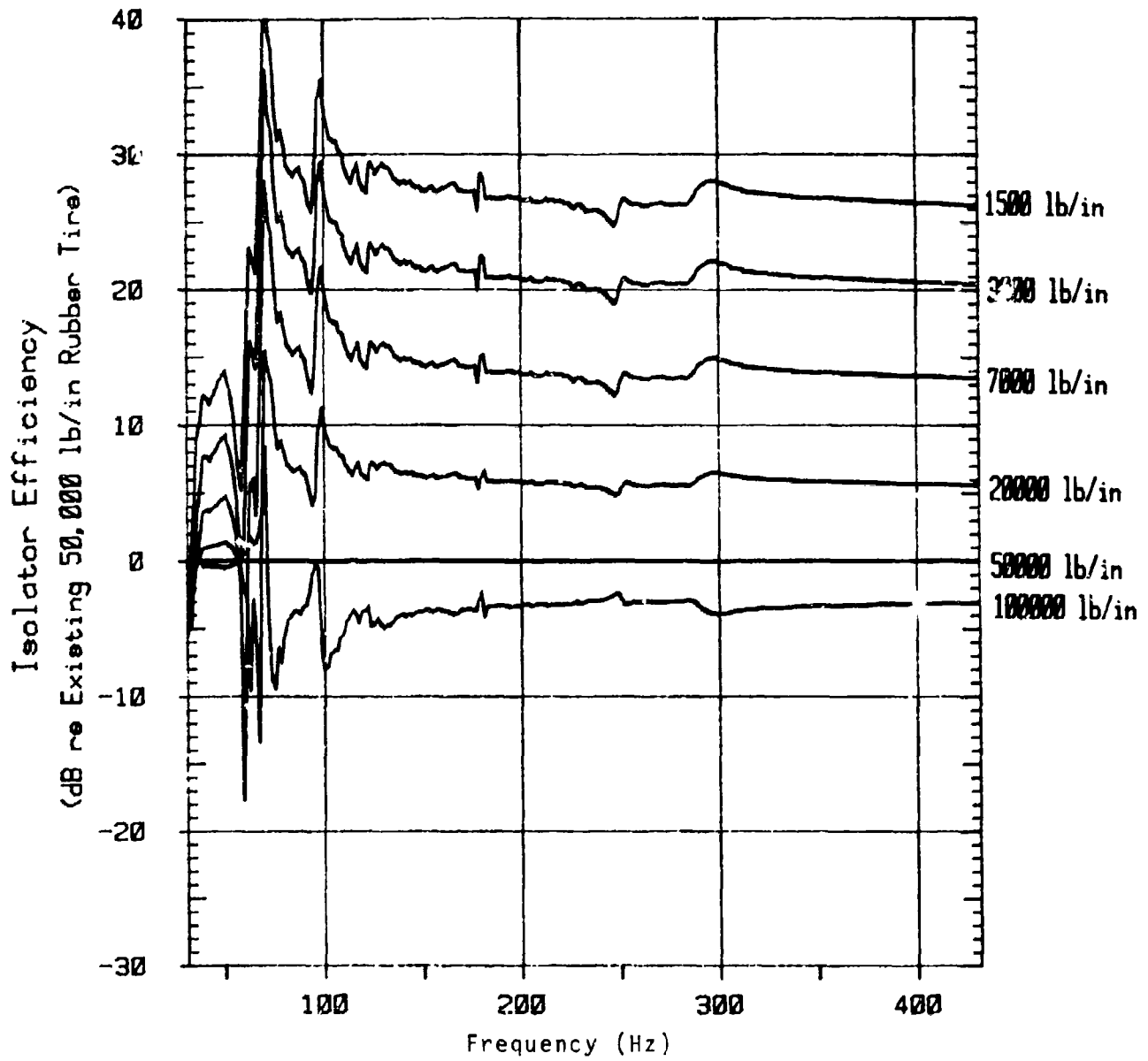

Figure 3.1 Calculated Isolator Efficiency for Compliant Roadwheel.
 Family of Curves are for Various Tire Spring Rates.

The shortcomings of the model are that:

- o The insertion loss calculation is based on measurements of an existing tire, which is greatly affected by the estimate of the amount of surface contact between the tire and the track.
- o Only vertical forces were modeled. Horizontal forces may become significant during turns when the steel track guides contact the roadwheel disk.
- o The dynamics of track block tipping are not simulated.

The compliant tire was not selected for development because there is a significant technical risk in being able to meet the noise reduction goal while maintaining the minimum durability goal of 2,000 miles. A tire stiffness of 3,000 lb/in seems to approach the practical lower limit for a compliant tire. Even with the 3,000 lb/in compliance, the predicted noise reduction would not be achieved, especially the goal of 22 dB minimum in the 250 Hz octave band.

3.2.2 Lower Side Plate Isolation

The second concept consisted of a lower side plate or frame isolated from the hull lower side plate by rubber isolation mounts (see Figure 3.2). The roadarms would then be bolted to the isolated plate or frame. This concept was rejected because subsequent tests of hull mobility indicated that the hull area, where the top edge of the lower side plate joins the sponson, has a high mobility. Thus, vibration energy would be easily transmitted into the hull, even through vibration-isolation mounts. This problem could not be overcome using very soft rubber mounts because of the large deflections experienced by soft mounts under load.

3.2.3 Isolated Chassis

The isolated chassis concept is a logical extension of the isolated lower side plate concept. This concept utilizes a separate chassis onto which the roadarms, final drives and idler wheels are mounted, with the rest of the vehicle mounted to the chassis on vibration isolation mounts. This concept has the advantage of providing excellent interior noise reduction capability while using standard suspension components. Although modification of existing vehicles with an isolated chassis would be very difficult and costly, incorporation of an isolated chassis into a new vehicle design would provide improved noise reduction with very little cost penalty.

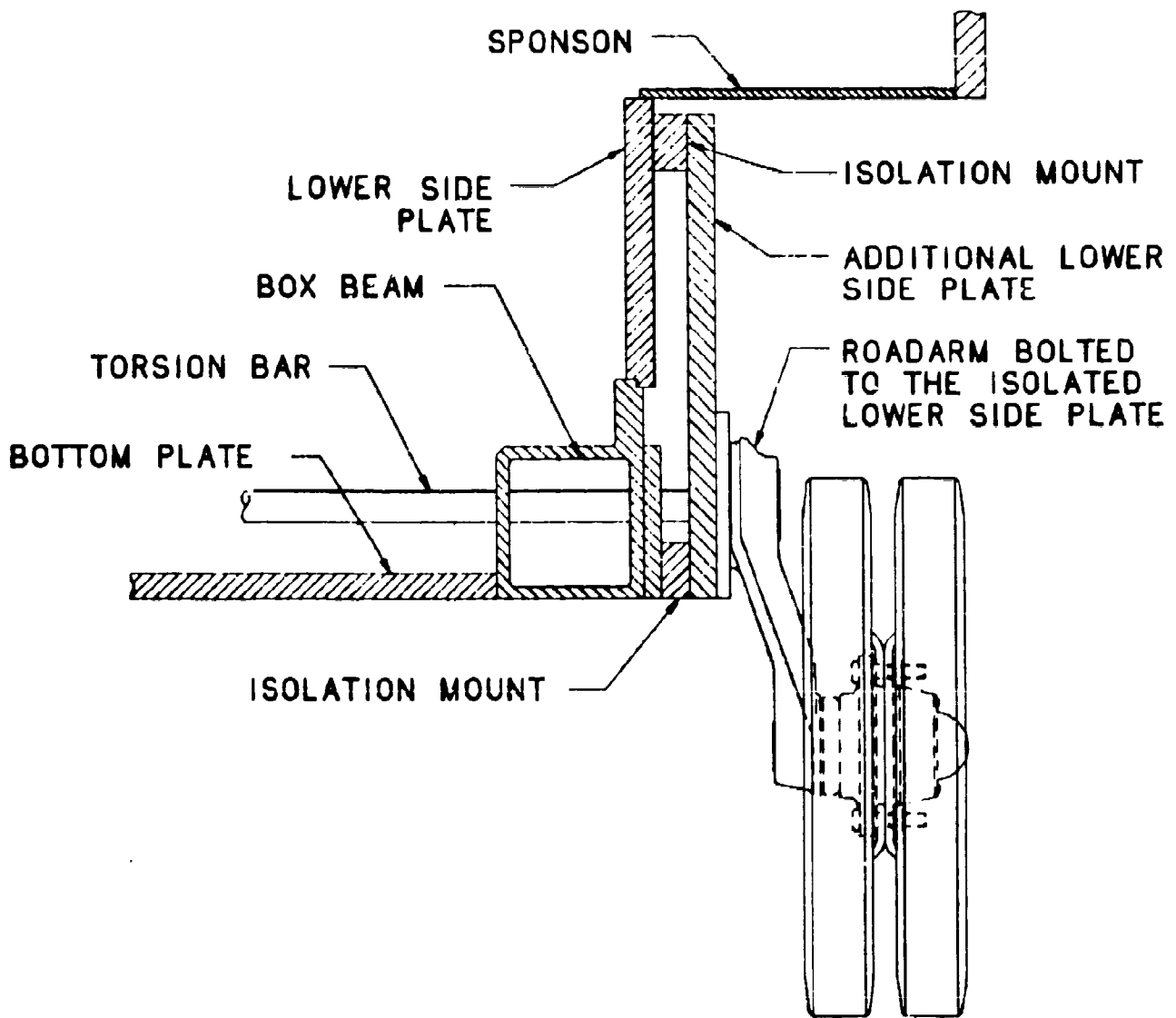

Figure 3.2 Isolated Lower Side Plate Concept

3.2.4 Isolated Roadarm

The fourth concept, the isolated roadarm, is shown in Figure 3.3. This concept was chosen for further development primarily because it offered the greatest noise reduction potential at the lowest cost. Two rubber shock mounts isolate linear and rotational roadarm vibration from the hull and support the vehicle's weight. A tube, extending across the vehicle to bear moments caused by the weight of the vehicle on the roadwheel, is anchored at the far end by another rubber isolator.

Advantages

The major advantages of the isolated roadarm concept are:

- o Good force isolation qualities
- o Simple, low-cost components
- o Quick and easy manufacture through use of off-the-shelf isolation mounts
- o Protected rubber (because of its location, partly inside the vehicle)
- o "Get-home" capability even with rubber failure
- o Extreme overload capability without rubber failure

Disadvantages

Disadvantages are:

- o Necessary hull modifications
- o Possible reduction of hull damping, presently provided by the track and suspension, which may result in less noise reduction
- o Noninterchangeability with standard components

3.3 Design Considerations of Roadarm Isolator

The isolator effectiveness of linear (not rotational) loads for several stiffnesses was calculated as a function of frequency and is shown in Figures 3.4 and 3.5 for vertical and horizontal forces. The estimated noise reduction will be the same as the calculated isolation efficiency. (The noise reductions for torques were not calculated because the rubber mounts are very soft in rotation, causing negligible vibration energy transmission from torsional loads.) As may be seen, an isolator pair (two mounts are required to share the load) with a minimum total spring rate of 10,000 lb/in. will ideally provide a noise reduction for vertical and transverse forces of 16 dB or more between 100 and 150 Hz. A minimum noise reduction of 21 dB may be expected at levels above 150 Hz.

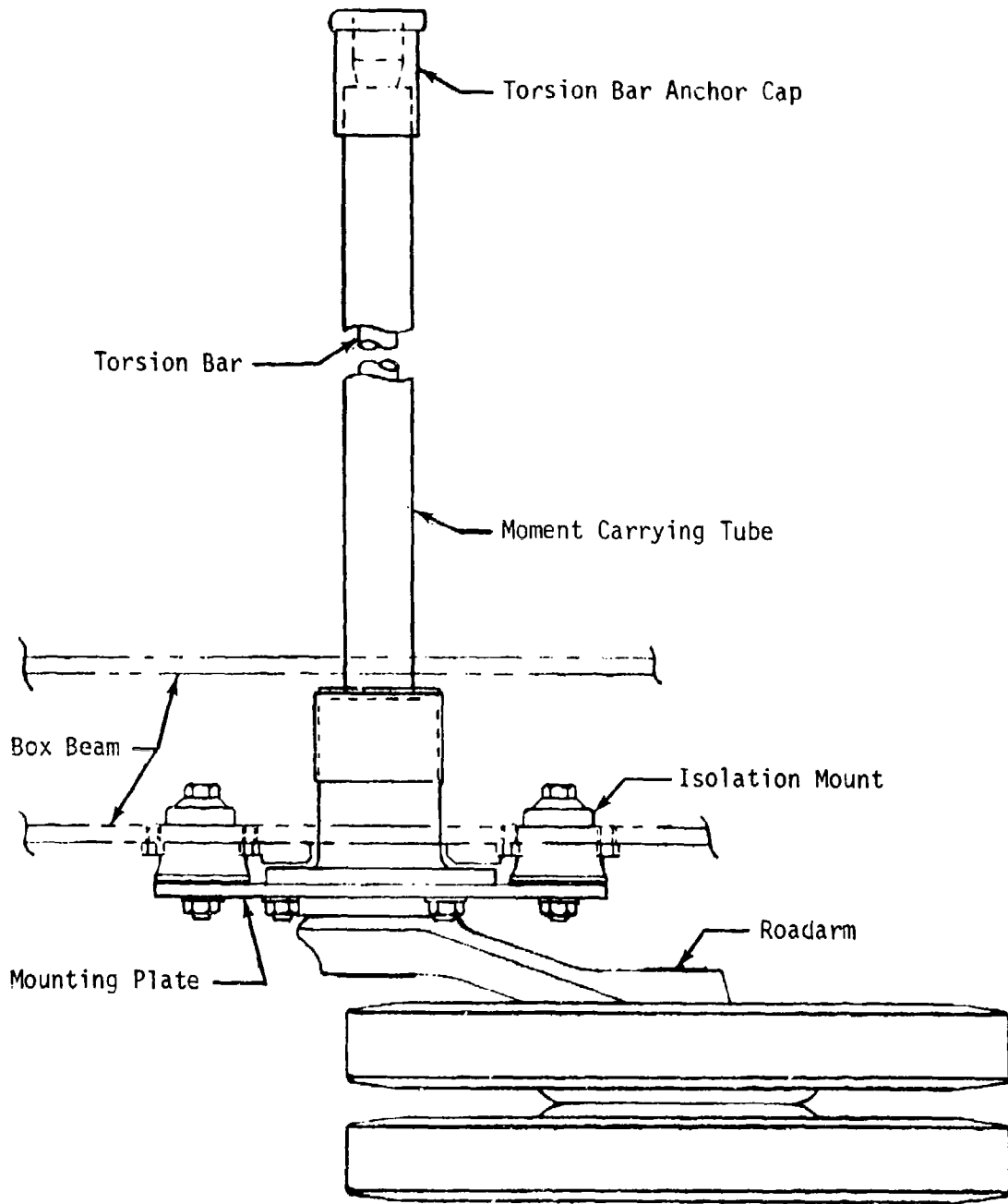

Figure 3.3 Isolated Roadarm Concept

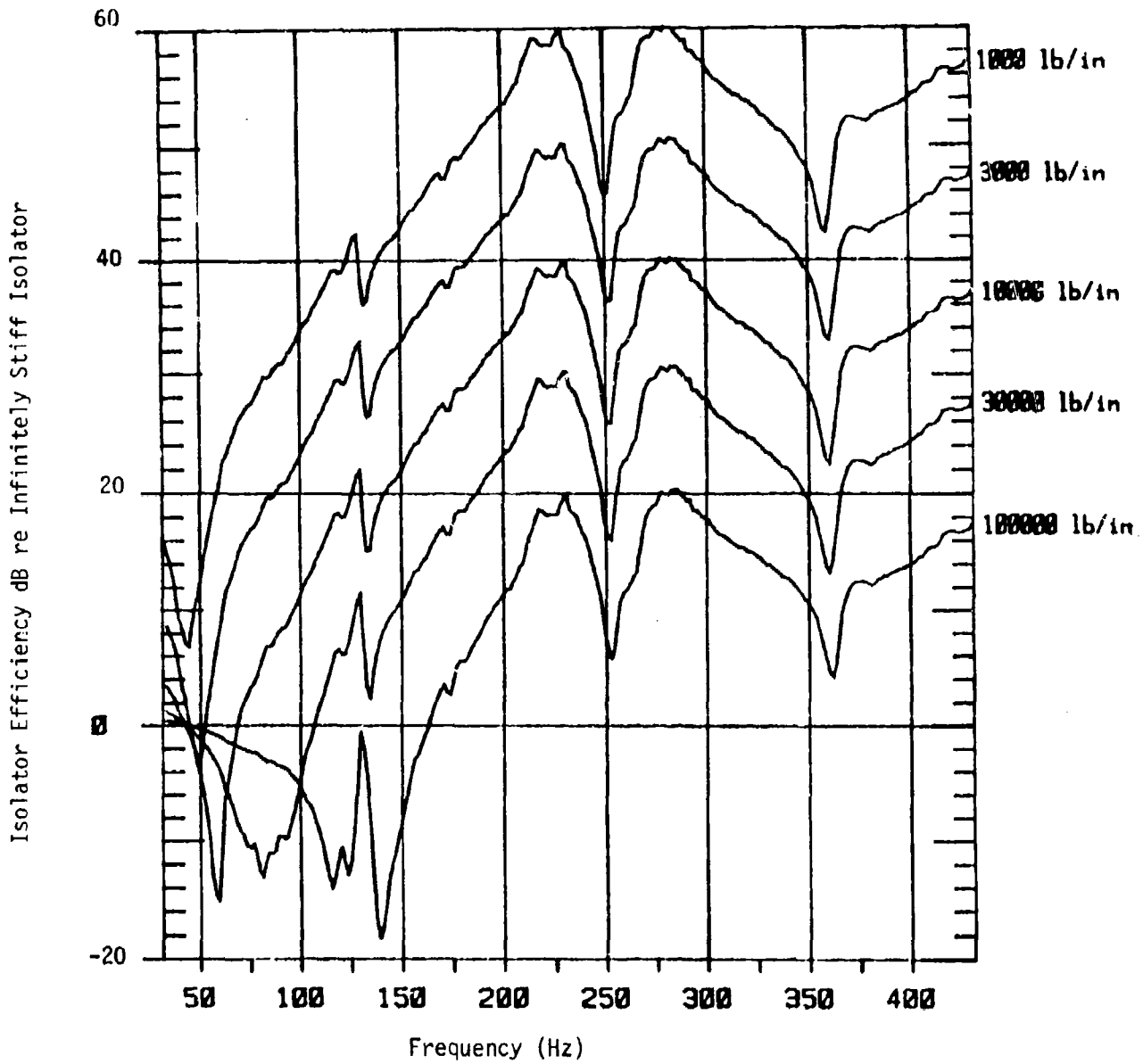

Figure 3.4 Roadarm Isolator Efficiency Calculated for Various Isolator Spring Rates in the Vertical Direction.

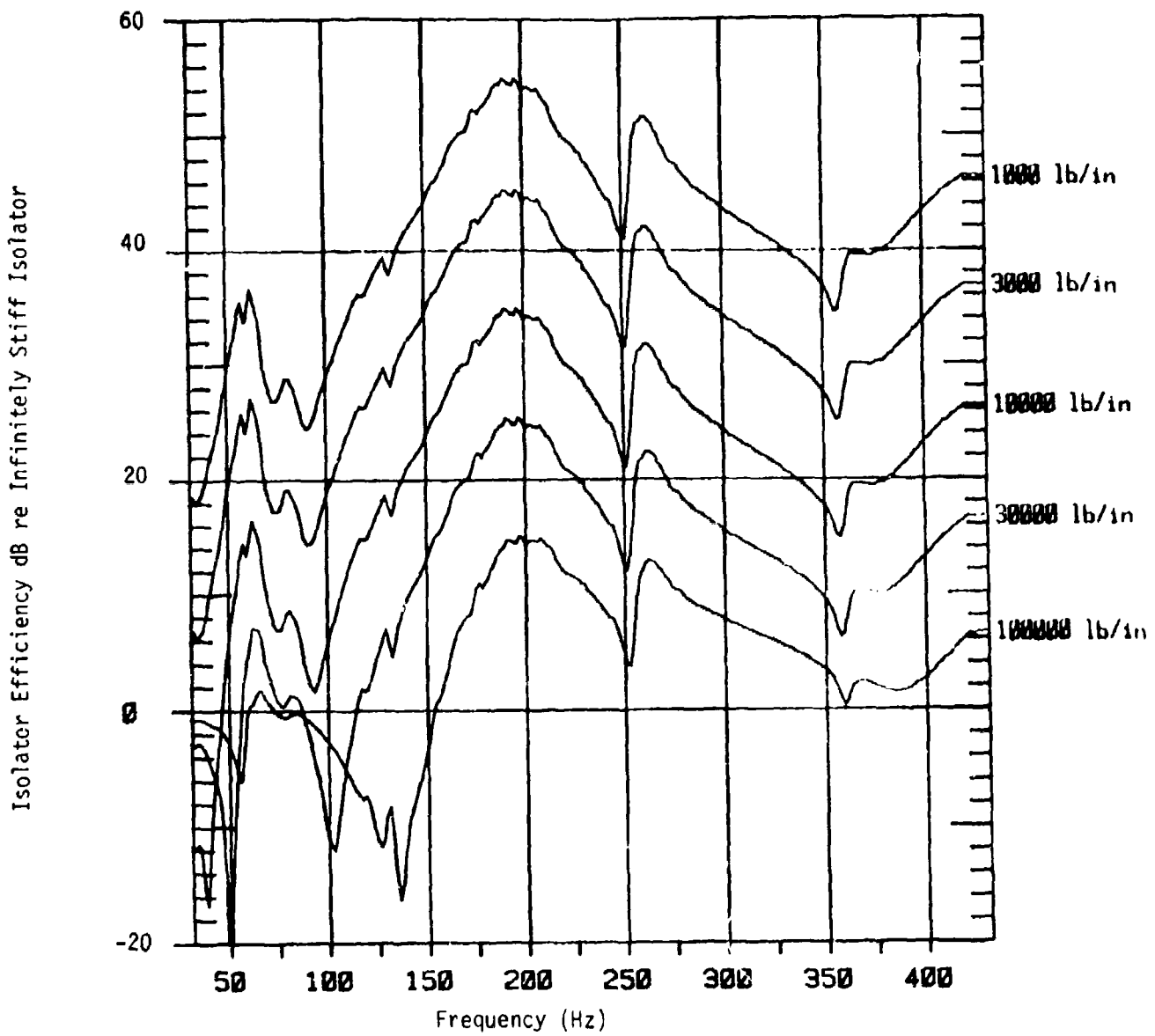

Figure 3.5 Roadarm Isolator Efficiency Calculated for Various Isolator Spring Rates in the Transverse Direction.

The isolator efficiencies shown in Figures 3.4 and 3.5 were calculated from test data measured on the roadarm and the vehicle hull. The roadarm measurements were made with the roadwheels resting on a firm surface and then resting on a foam rubber pad. The calculated efficiencies shown in Figures 3.4 and 3.5 used measurements where the roadwheels were on a firm surface. Efficiencies calculated where the roadwheels were resting on a resilient surface were similar except that the low frequency dips are shifted in frequency.

For experimental design purposes, a mount was chosen with a stiffness under normal load of 10,500 lb/in. per mount, or 21,000 lb/in. per mount pair. This mount had a higher stiffness than desired, but was chosen because it was the softest off-the-shelf isolator which would carry the load and fit into the available space. Compared to the 10,000 lb/in. stiffness discussed above, the noise reduction would be reduced by approximately 7 dB above 125 Hz, and reduced by a maximum of 10 dB between 50 and 125 Hz. More importantly, this higher stiffness isolator would resonate near or just below 100 Hz resulting in a predicted noise amplification at this frequency.

Figure 3.6 is a photograph of the experimental roadarm used for testing. The vibration mounts chosen are Barry No. 512-4, with a linear spring rate for each individual mount of 8,300 lb/in. unloaded and 10,500 lb/in. under the normal load of 1,250 pounds. For each mount, the shock overload capability exceeds 10,000 pounds.

4. TEST PROCEDURES

This section describes the apparatus, the procedures and the mathematical basis for the experimental roadarm tests. Experimental techniques used in obtaining engineering data, chiefly mechanical point mobilities and noise-to-force transfer functions, are also described in this section.

4.1 Identification of Roadarm Vibration Energy Paths

During testing of the isolated roadarm mount, it was noted that the torsion bar was a significant transmitter of vibration energy to the hull. A previous study conducted by Bolt Beranek and Newman (BBN) for FMC [10], concluded that the torsion bar was not a significant energy path, compared to the standard (nonisolated) roadarm mount. The BBN study was conducted by isolating the anchor end of the torsion bar from the hull and measuring the interior noise-to-roadarm-acceleration transfer function. Essentially no difference was measured with the torsion bar attached or detached from the hull.

The experimental isolated roadarm was initially designed to use the standard torsion bar anchor to react against the roadarm torque. The isolated roadarm design was later changed to isolate the torsion bar anchor from the hull. With the torsion bar isolated, an average 10 dB



Figure 3.6 Experimental Roadarm Mounted on Mil3A1 Vehicle

insertion loss was measured for the isolated roadarm in the frequency range of 160 to 800 Hz. This shows that the torsion bar is a significant roadarm vibration energy path only if the more significant path through the roadarm trunion bearing mount is first eliminated.

4.2 Mathematical Basis for Noise Reduction Predictions

The noise reduction achievable, using an isolator to decouple the roadarm from the hull, is largely dependent on the ratio of the spring rate of the isolator to that of the attachment points. A simplified model of the roadarm isolation system (Figure 4.1) was used to calculate the isolator effectiveness [9]. For this conceptual model, where motions along one axis at a time are considered and the mass of the compliant element is insignificant, the isolator efficiency then obeys:

$$E = \left| 1 + \frac{M_I}{M_S + M_R} \right| \quad (4.1)$$

and in decibels,

$$E_d = 20 \log E \quad (4.2)$$

Where:

M_I = mobility (i.e., the complex ratio of vibration velocity-to-force) of the resilient elements (the "isolator")

M_S = mobility of the roadarm (the vibration "source")

M_R = mobility of the vehicle hull (the "receiver")

E = isolator efficiency

E_d = efficiency expressed in decibels

The mobilities of the source and receiver were measured over a frequency range of 30 Hz - 430 Hz; however, the mobility of the isolator was calculated to be that of an undamped massless spring:

Where: $M = i\omega/k$

M = isolator mobility

k = spring rate of the isolator

ω = radian frequency

$i = \sqrt{-1}$

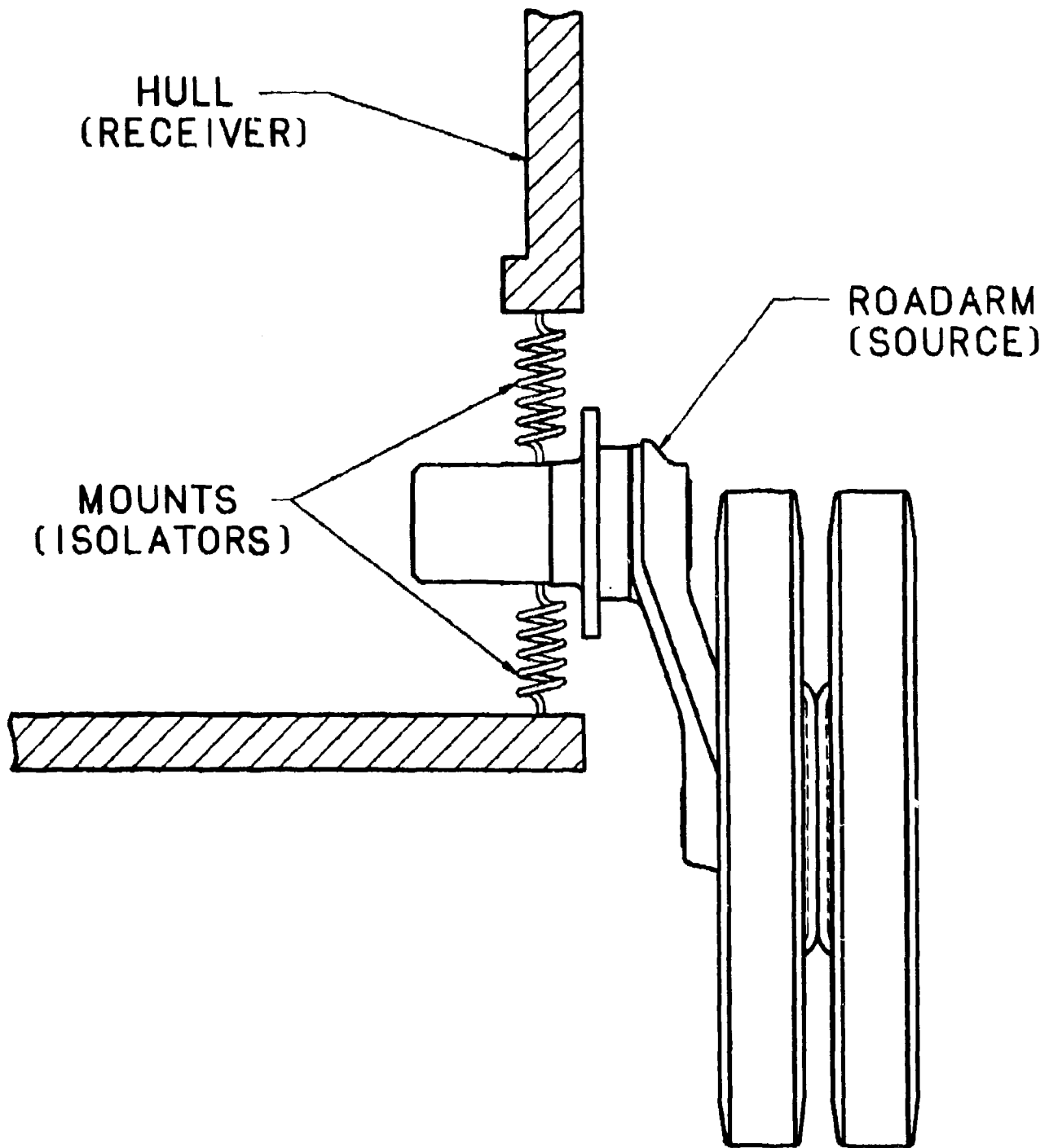

Figure 4.1 Simplified Model of an Isolated Roadarm

The calculated isolator efficiency as a function of frequency for various isolator spring rates is shown in Figures 3.4 and 3.5. The efficiency may be taken as the noise reduction predicted for each isolator spring rate. Actual reductions in dB will range from about one-half to all of the predicted amount.

4.3 Measurement Procedures for Mobilities and Noise-to-Force Ratios

Measurements of mobilities and noise-to-force ratios were made on the hull, roadarm, and roadwheel rim. The resulting data were needed to aid the noise control hardware designers by identifying regions of the hull best suited for the attachment of vibration isolators and predicting the noise reductions for candidate designs.

As has been mentioned previously, the noise reduction obtained from a vibration isolator is as dependent on the rigidity of both attachment points as it is on the softness of the isolator. However, practicality dictates that vibration isolators in the suspension have limited deflections, which in turn requires rather stiff mounts. Because stiff mounts do not reduce noise appreciably, the mounts must be attached at positions of low mobility to maintain adequate noise reduction. Typically, these positions will be at the corners of a structure assembled from plates. The measurement procedures described in the following paragraphs were used to find which corners had the least mobility.

To predict noise reduction due to isolating roadarm vibration from the hull, it is necessary to measure the mobilities of the roadarm and hull along all vectors where significant vibration energy will be transmitted as forces or torques. For the roadarm, the mobilities were measured only in the vertical and horizontal directions. It was assumed that the hull would readily accept vibration energy in the form of a torque around an axis which is parallel to the intersection of the bottom and lower side plates. Thus, such torques must be eliminated in any practical design, perhaps by a structural member extending across the bottom of the hull and anchored in a suitable manner at its far end. Later analysis showed this assumption to be correct, and only rudimentary measurements of "mobility in torque" or noise-to-torque ratios were necessary.

The mechanical point mobilities were measured using either an electrodynamic shaker or a small hammer as the vibration source and an accelerometer placed near the vibration source to detect the response. Both channels of data were analyzed with a Hewlett Packard model 5420A signal analysis system. The basic test setup is shown in Figure 4.2. This analyzer was interfaced with a Hewlett Packard 9825T computer. With suitable programming, it was possible to predict the expected noise reductions directly on a narrow band spectrum basis. This noise reduction is identical to the isolator effectiveness "E" for practical purposes (as described by equations 4.1 and 4.2).

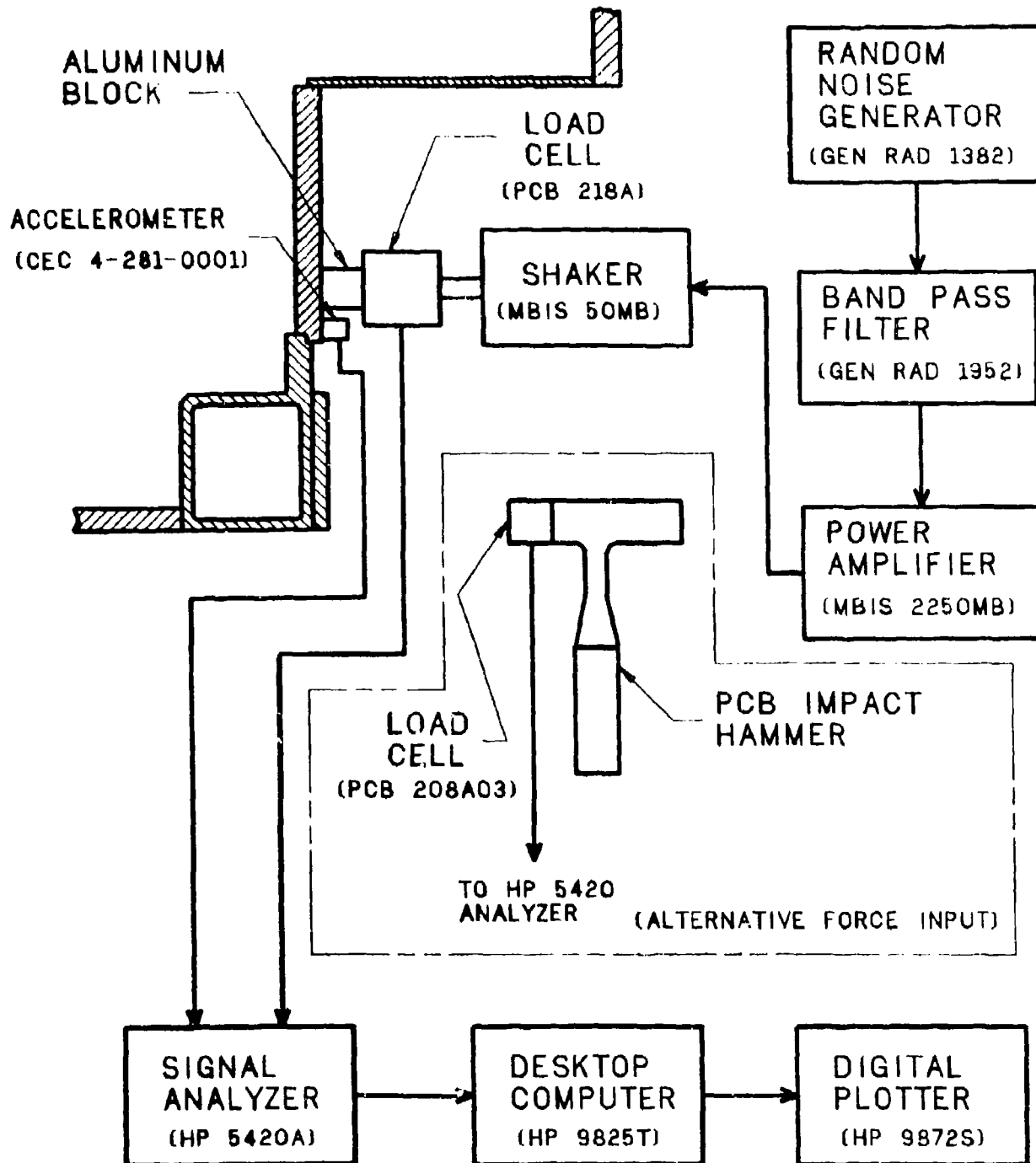

Figure 4.2 Instrumentation Setup for Mechanical Mobility Measurements

The roadarm mobilities were measured in two ways. First, the roadarm without a wheel attached was measured while suspended by elastic cords. In this configuration, the roadarm is essentially free to vibrate with little interference from the supports. A small hammer and force gauge provided the force input. Measurements were made at several points and along two axes, with the most significant data being in the vertical direction at the roadarm mount bearing. The measured mechanical point mobility as a function of frequency is shown in Figure 4.3. In the frequency range below 400 Hz, there are no sharp roadarm resonances which would impair noise reduction.

A more realistic mobility was measured at the same locations after attaching a roadwheel. The roadarm was suspended as before at its inboard end. For one set of tests, the roadwheel bottom rested on a soft foam rubber pad in the position of the track on an assembled vehicle. The other test was conducted with the roadwheel sitting directly on a hard floor. Again, the most significant mobility was in the vertical direction; this simulates the actual suspension. Figure 4.4 shows the mobility as a function of frequency. Introducing the roadwheel added a number of sharp resonances which are expected to produce corresponding dips in the noise reduction obtained below 400 Hz.

The preceding procedures were used to measure the mobility on the roadarm side of the proposed isolator. The following paragraphs describe measurements on the hull side of the proposed isolator.

The initial hull measurements were made primarily to screen mounting locations for the vibration isolators. The potentially good locations to be checked were the bottom corner of the hull, that is, within several inches of the corner of the box beam, and where the lower side plate joins the sponson. It was also desired to quantitatively compare the mobility for a twisting moment applied to the box beam rather than a force. For this purpose a test fixture was made which was simply a length of stiff steel pipe extending 9 inches out from the hull with a force being applied at its outer end. Mobility measurements were also made at locations on the box beam, the bottom plate, and the lower side plate. These positions and the corresponding mobilities relative to the bottom corner of the hull measured at 250 Hz are shown in Figure 4.5. The mobility measurements were initially made in a plane even with the No. 3 roadarm mount position. This position was expected to have the highest mobility of any roadarm position, that is, a vibration isolation system would be the least effective here. Later measurements, made at the No. 1 and No. 5 roadarm positions, verified that the No. 3 roadarm position did indeed have the highest mobility.

Noise-to-force transfer functions were also measured at the same locations on the hull where mobility measurements were made. The purpose of the noise-to-force measurements was to gain additional confidence in the selection of mounting locations for the vibration isolators. The map of relative noise-to-force transfer function measurements at 250 Hertz is

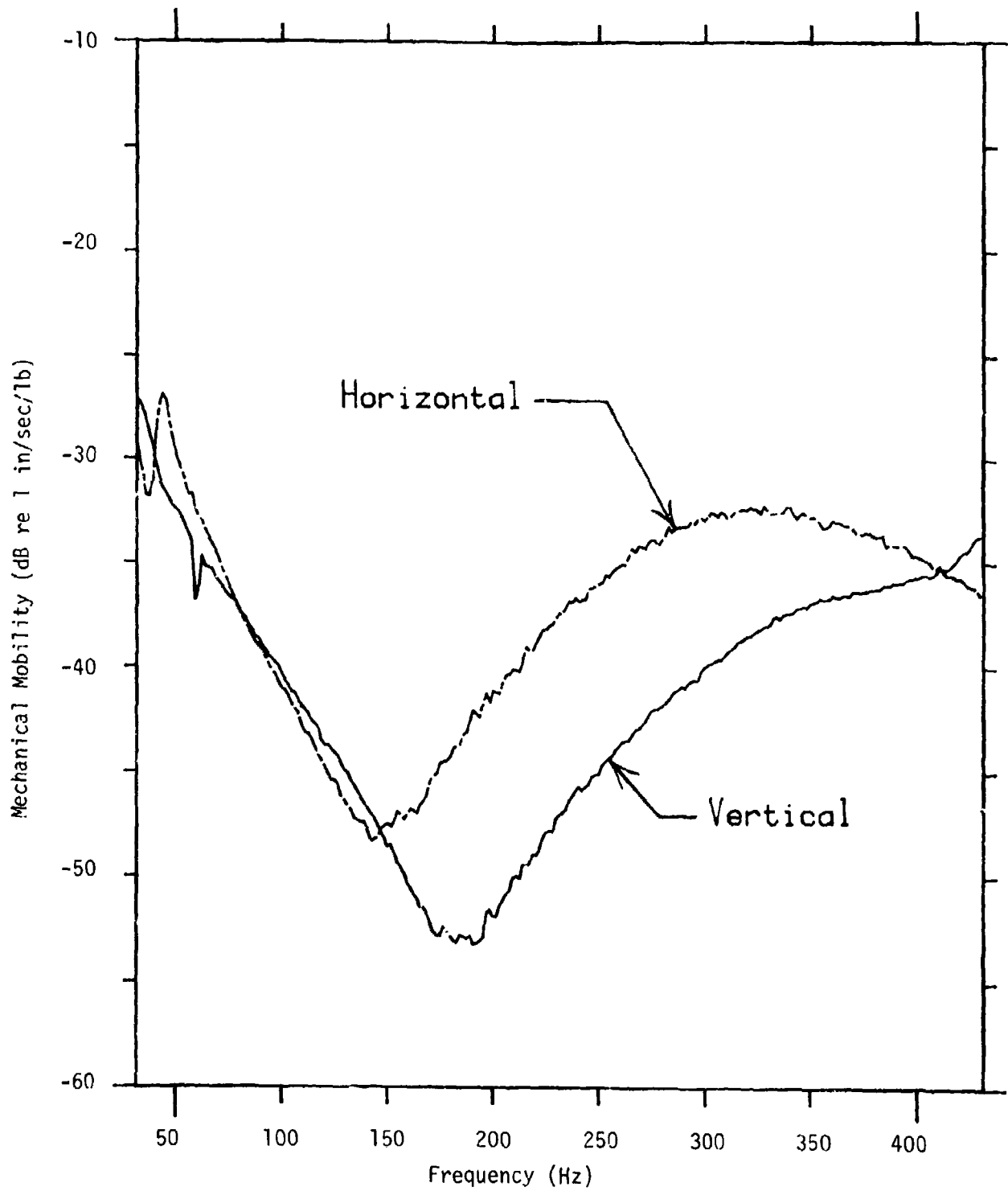

Figure 4.3 M113A1 Roadarm Mobility without Roadwheels Attached.

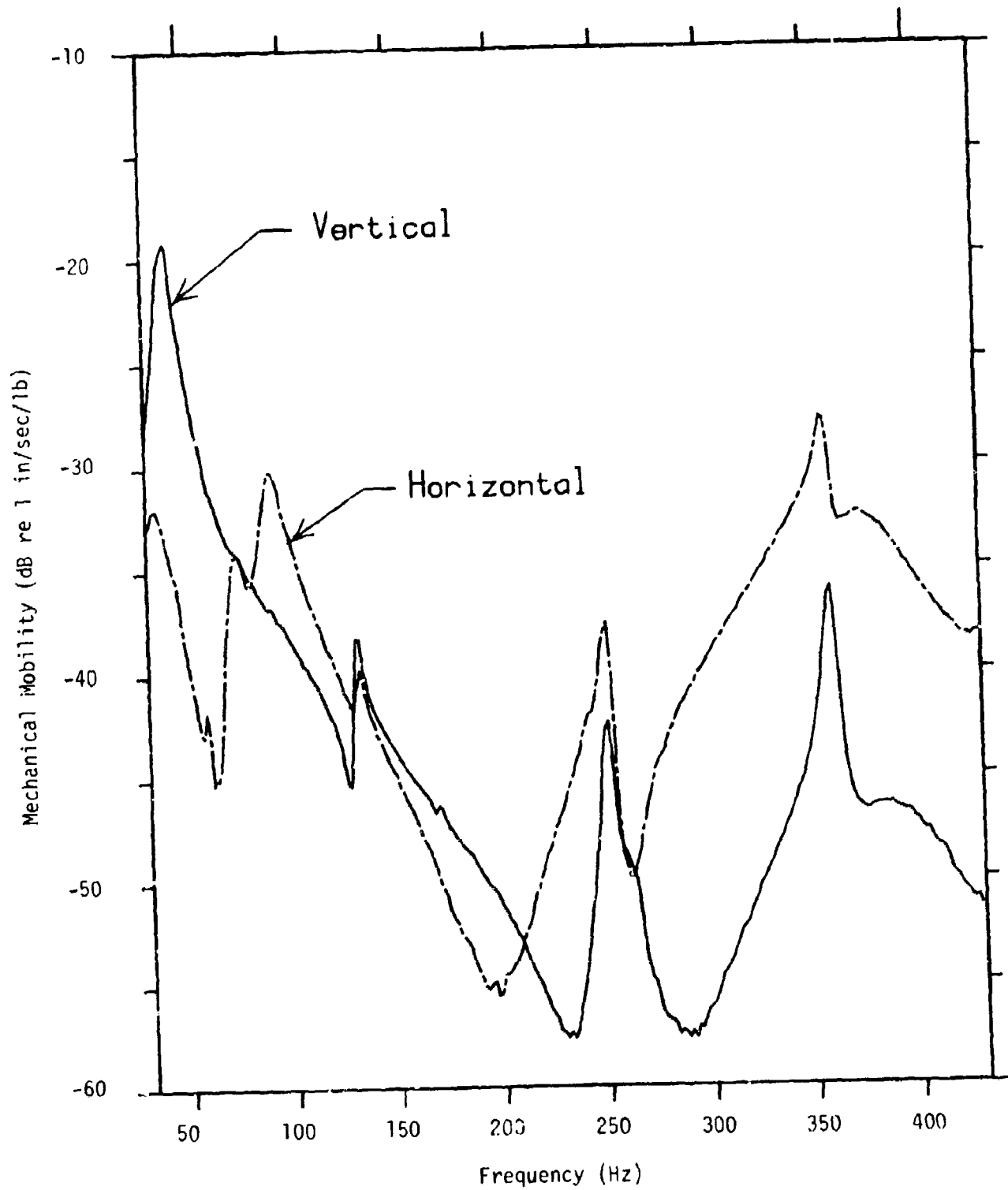

Figure 4.4 M113A1 Roadarm Mobility with Both Roadwheels Attached.

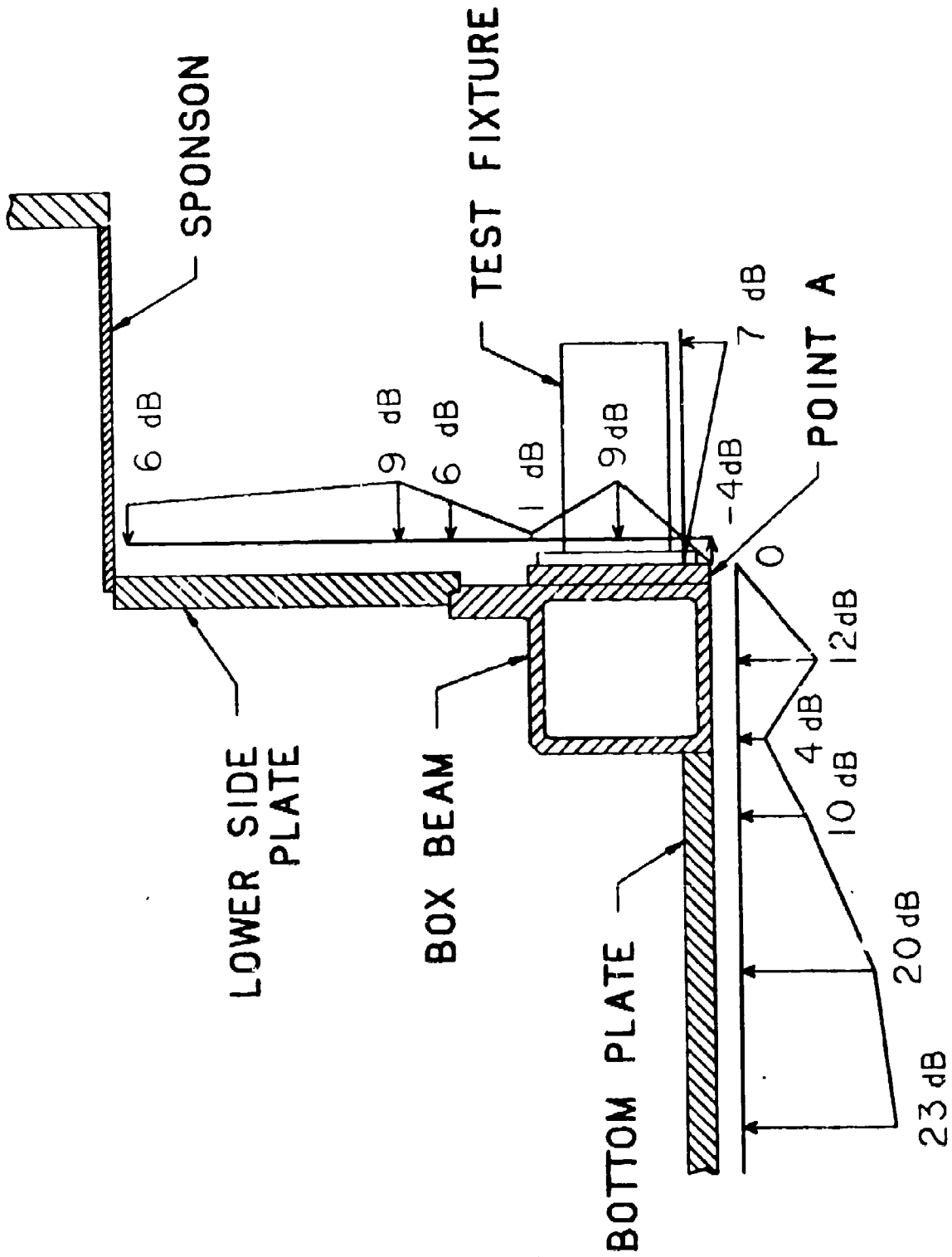

Figure 4.5 M113 Hu11 Mobilities at 250 Hertz Relative to the Bottom Corner (Values are dB re 1 in/sec/lb)

shown in Figure 4.6. The relatively small variation in the noise-to-force transfer functions at the centers of the box beam sides (-1 and +3 dB), compared to the large increase in mobility at these locations (+12 and +9 dB, Figure 4.5), indicates that the box beam has some local resonances which do not effectively radiate sound energy into the vehicle.

The results of the mobility and noise-to-force ratio measurements showed that the location of the isolation mounts should be kept as close as possible to the bottom corner of the hull for maximum isolation effectiveness.

4.4 Test Procedure for Roadarm Mount Evaluation

Several procedures for evaluating the noise reduction achieved by the experimental compliant roadarm mount were considered, including the following:

- o Equipping the M113 with 10 compliant roadarm mounts and towing it around the track.
- o Modifying the existing electric drive test stand to provide for ground effects and loading on the roadwheels.
- o Developing a new low-noise test stand and apparatus capable of realistically simulating the normal downward force which the roadwheel exerts on the track.

The above test procedures were rejected as a means of evaluating the compliant roadarm mount because of the following practical constraints:

- o The actual vehicle has 10 roadarms, but it was not economically feasible to fabricate and install more than one compliant roadarm mount.
- o It was not feasible to test even one compliant roadarm mount on FMC's electrically driven test stand because the test stand itself is too noisy. Building a new quieted test stand would be a major expense and may still produce too much sprocket engagement noise.
- o In any stationary test stand, there would be significant technical risk of improper simulation of the track-roadwheel dynamic interaction, including track block tipping.

The test method which was selected for the compliant roadarm mount evaluation was to apply force to the roadwheel using an electrodynamic shaker and measure the resulting interior noise-to-force ratios. These ratios were then used to calculate the noise reductions that would be achieved for a vehicle with all 10 compliant roadarms. Because the hull has different dynamic characteristics at each of the 10 roadarm mount positions, the one position used in the test is not necessarily representative of the other nine positions. The number 3 roadarm position was selected for testing because this position has the highest noise-to-force ratio of all roadarms (see Figure 4.7).

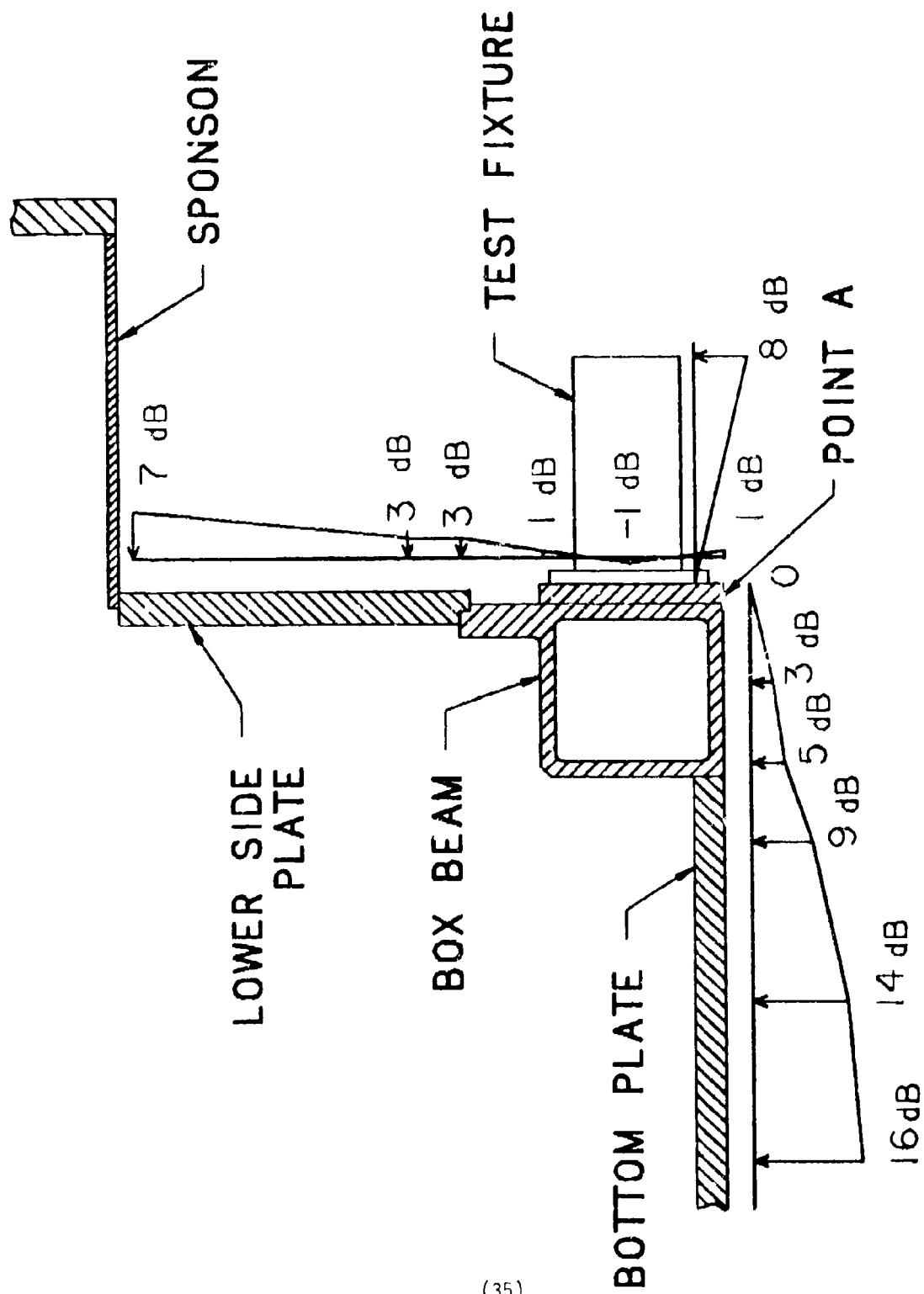

Figure 4.6 M113 Hu11 Noise-to-Force Transfer Functions at 250 Hertz Relative to the Bottom Corner
 (Values are dB re 20 μ Pa/1b)

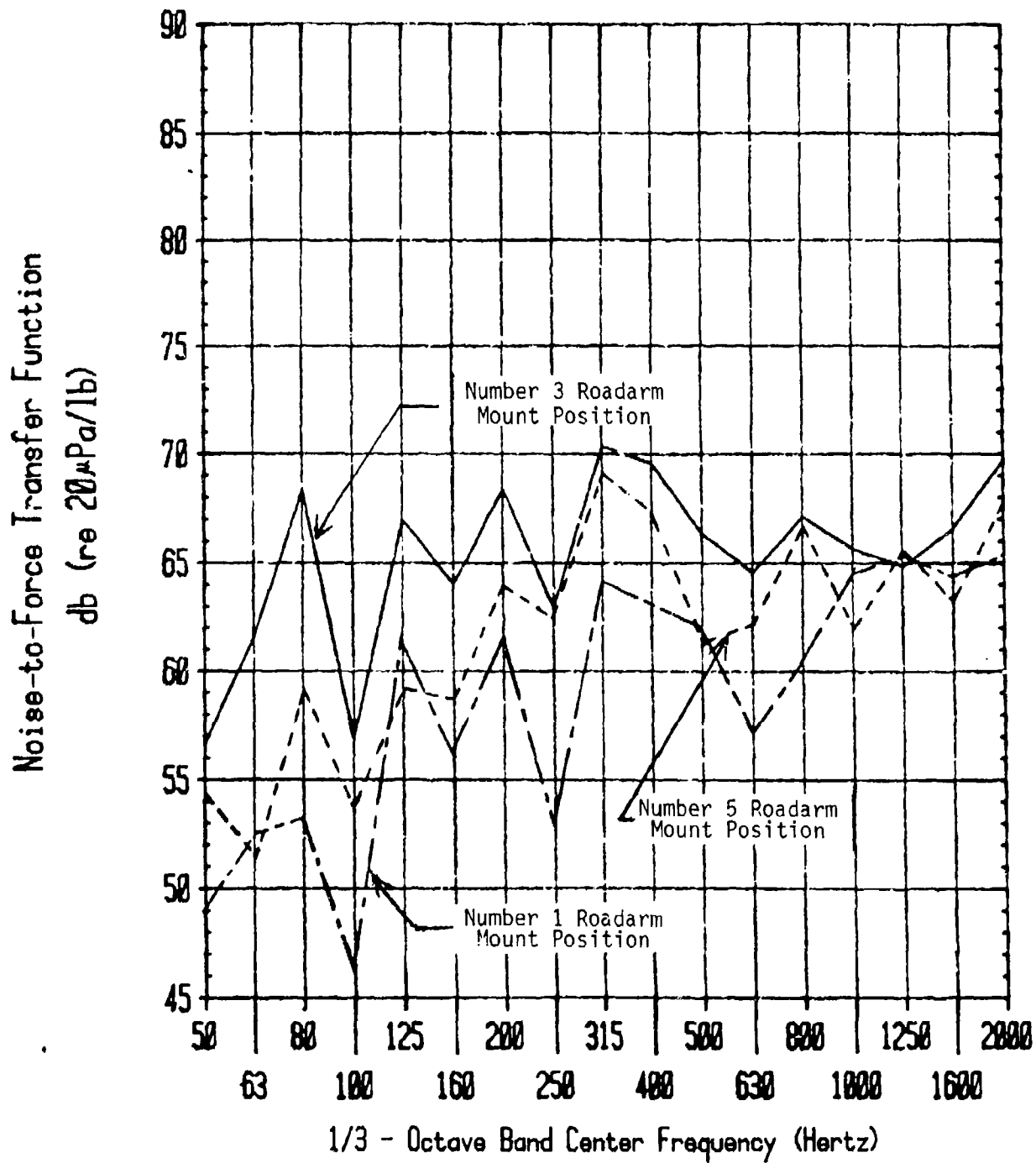

Figure 4.7 M113 HULL Noise-to-Force Measurements at the Bottom Outside Corner of the Box Beam with the Force Input Vertically

Using an electrodynamic shaker to excite the roadarm has several important benefits compared to driving the vehicle on a test track or raising the vehicle on a stand and rotating the track. In evaluating the noise reduction of the experimental roadarm, it proved to have the following advantages:

- o The force is highly controllable such as using a sine sweep for resonance and nonlinearity identification.
- o The force is consistently repeatable.
- o The signal-to-noise ratio is adequate.
- o The cost is low.
- o The experimenter is safe while making measurements, alterations, and observations within the immediate area of the track.

The shaker has the following disadvantages:

- o The relative importance of the roadwheel's vertical and horizontal forces is unknown, and so must be estimated based on experience and judgment.
- o Force levels generated by the shaker are lower than actual vehicle operational forces; consequently, nonlinearities in the bearings and mount system may not be accounted for while testing with the shaker. However, these nonlinearities are believed to be of minor importance because the bearings were fully loaded to eliminate slack.
- o The spectrum shape of input force is different than during vehicle operation; therefore, there is no direct comparison to noise levels generated during vehicle operation. Instead, a noise reduction comparison is only possible on a frequency-by-frequency basis, and any A-weighted noise reductions must be calculated rather than directly measured.

An electrodynamic shaker of 50 pounds-force capacity was attached to the roadwheel rim. The vibration force on the roadwheels during normal operation is mostly in the vertical direction, with side loads being introduced during turns and in rough terrain. Accordingly, both horizontal and vertical forces were applied during the tests. Figures 4.8 and 4.9 are photographs of the test configuration. The vertical shaker force test results were weighted most heavily when evaluating the noise reduction of the experimental roadarm mount.

For most of the tests, the input signal to the shaker was band-limited random noise. The resulting interior vehicle noise was measured at a point near the center of the crew compartment. Several practical problems had to be overcome. First, to take up bearing slack, it was

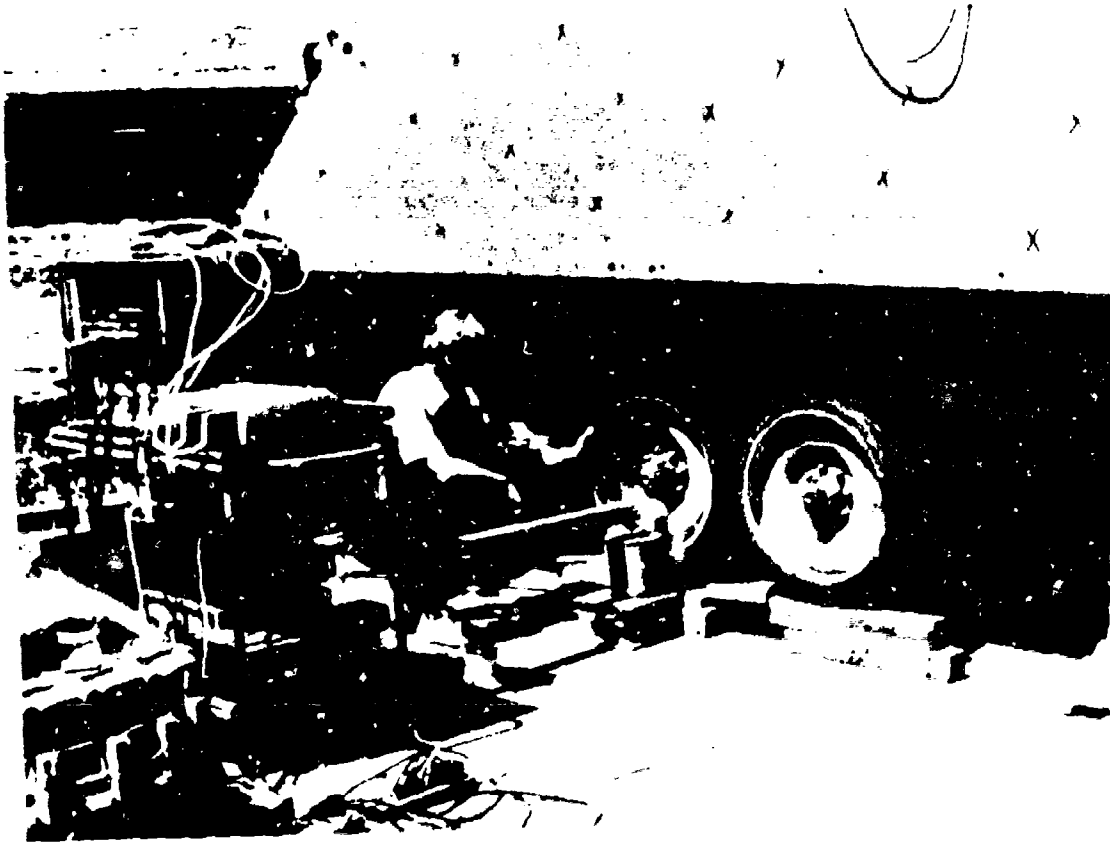

Figure 4.8 Experimental Roadarm Test Setup with the Force Input in the Vertical Direction

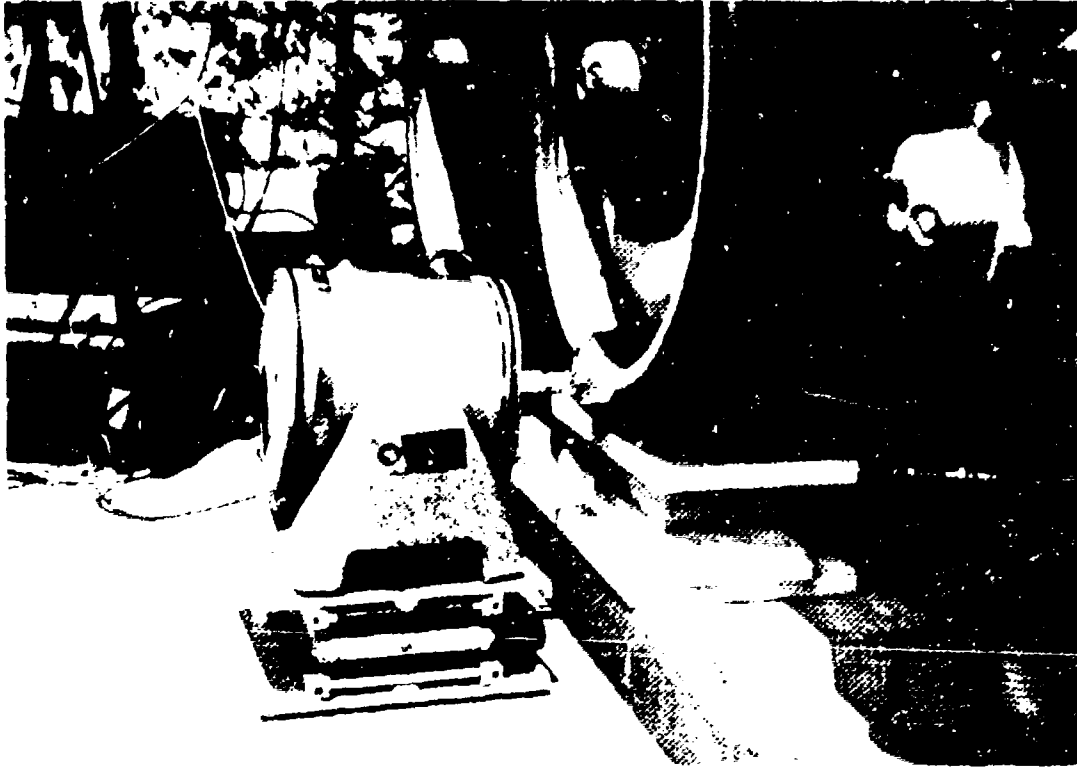

Figure 4.9 Experimental Roadarm Test Setup with the Force Input in the Transverse Direction

desirable to have the roadwheel support its normal load of approximately 2,500 lbs. Second, it was not certain whether it would be more realistic to test with the roadwheel on a hard surface or on a soft surface; both conditions were tested. The hard surface consisted of wooden blocks. The soft surface consisted of a board under the roadwheel which rested on multiple layers of open-cell foam rubber. Each layer of foam was approximately 0.5 inch thick totaling a stack of approximately 3 inches thick. To prevent the foam from bulging excessively, cloth was bonded to one surface of each foam layer. This arrangement simulated a soft but resilient surface to support the full roadwheel downward force. Under load, the foam compressed roughly half of its unloaded height.

The electrodynamic shaker was connected to the roadwheel using a quartz force cell attached to a 1-inch cube of aluminum, which in turn was glued to the roadwheel rim, as shown in Figure 4.10. The roadwheel tire was in its normal configuration. To apply the vertical force, however, the shaker would not fit into a position along a radius extending inward from the roadwheel rim. Therefore, a rather unusual test fixture was designed and fabricated, as shown in Figure 4.11. It consisted of a cantilever beam with one end attached to the force cell and roadwheel rim, the shaker attached a few inches away, and a mass attached to the opposite end to act as a pivot point. The mass was supported on foam rubber. This mass-pivot lever system worked well and required no modifications or changes other than covering it to reduce radiated noise.

5. TEST RESULTS

Following engineering, design, and fabrication of the experimental roadarm, it was tested for its noise reduction capability. The results of the noise reduction testing, presented in this section, are interpreted in Section 6.

5.1 Interior Noise Test Results

The ratio of acoustic noise due to the applied vibration force is the noise-to-force transfer function. These noise-to-force transfer functions were used as the basis for measuring the noise reduction capability of the experimental roadarm (see Section 4.3 for a description of the test procedure). The normalized interior noise level measurements, or noise-to-force transfer functions for the standard or baseline roadarm configuration and the experimental isolated roadarm, are shown in Figures 5.1 and 5.2. These measurements were taken in the center of the crew compartment, with the force input to the roadwheel in the vertical and transverse directions. (Transfer function values are shown in Appendix B.)

By taking the difference between the standard and experimental roadarm mount noise-to-force ratios at each frequency, the insertion loss was calculated as a function of frequency. The insertion loss is plotted in

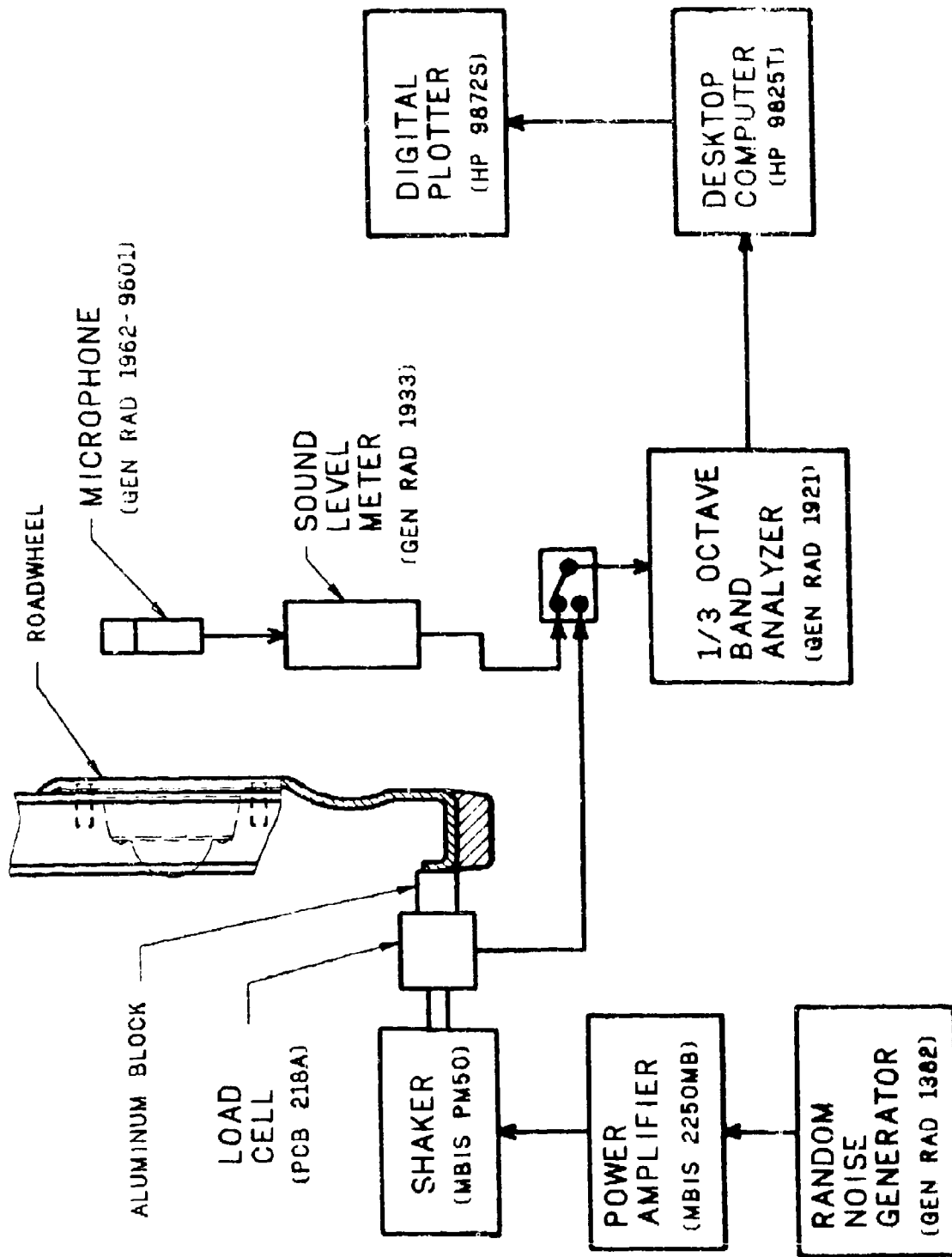
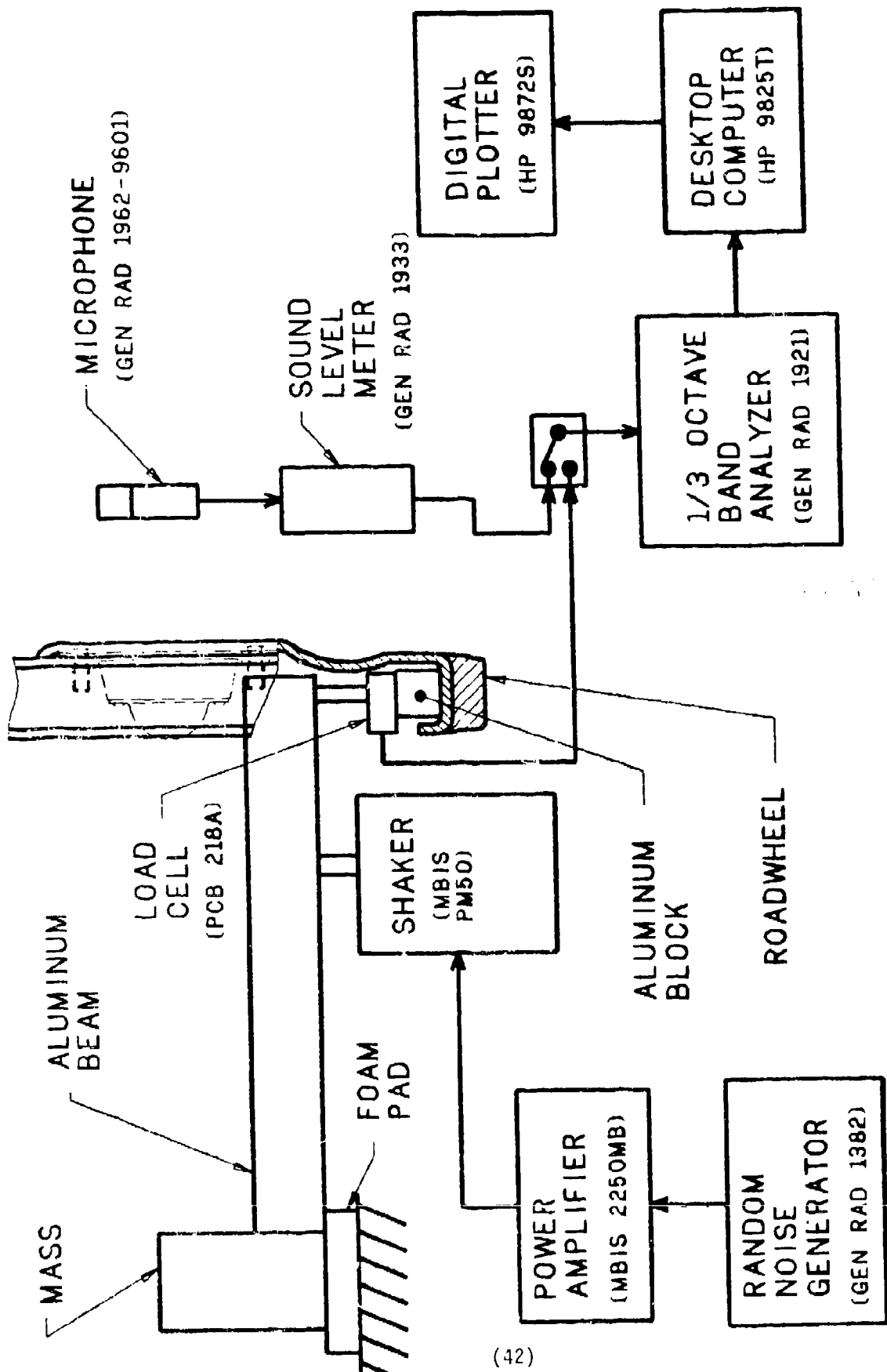

Figure 4.10 Instrumentation Diagram for Roadarm Noise Tests with the Force Input in the Transverse Direction



(42)

Figure 4.11 Instrumentation Diagram for Roadarm Noise Tests with the Force Input in the Vertical Direction

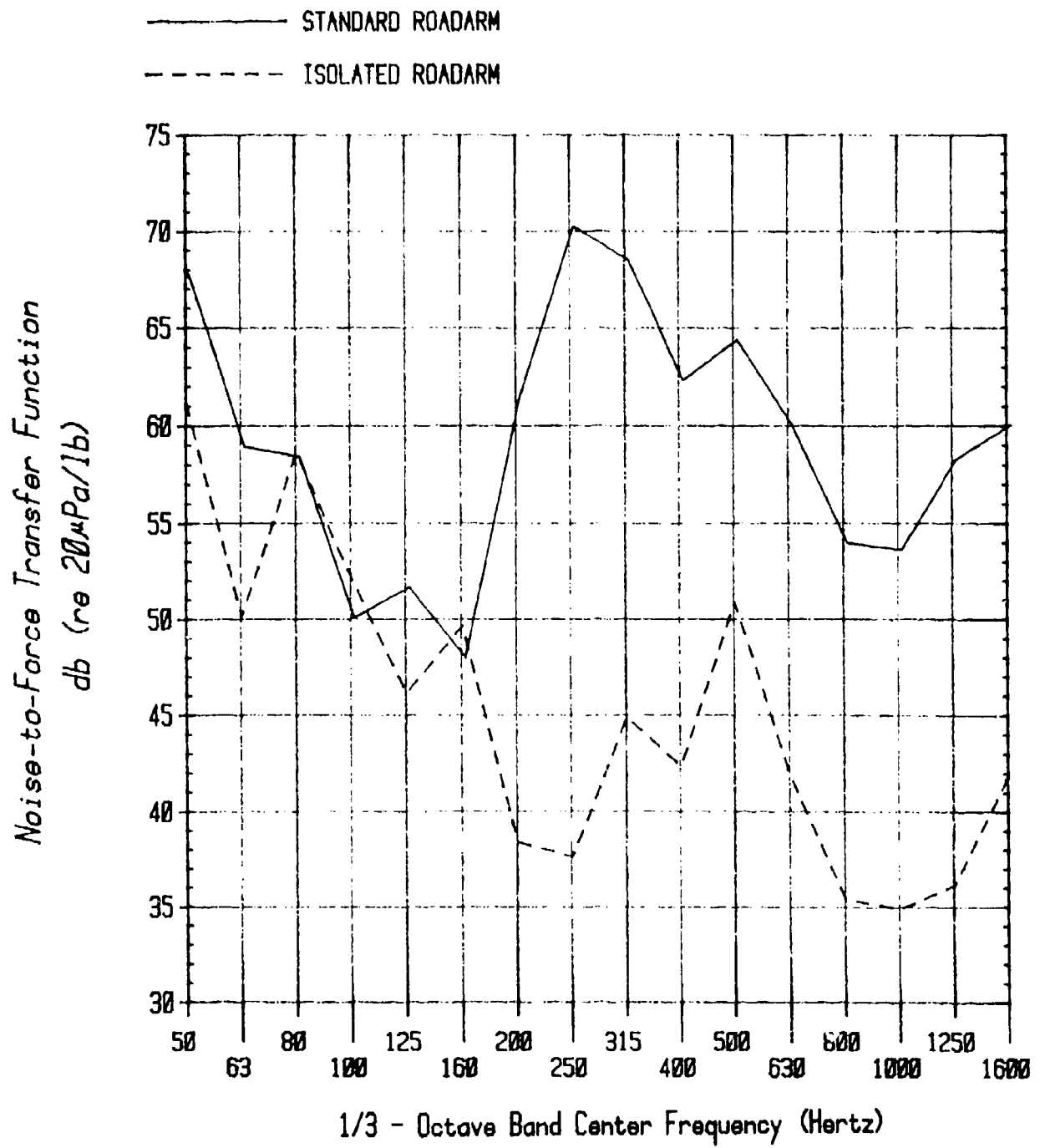

Figure 5.1 Noise-to-Force Transfer Function with the Force Input in the Vertical Direction.

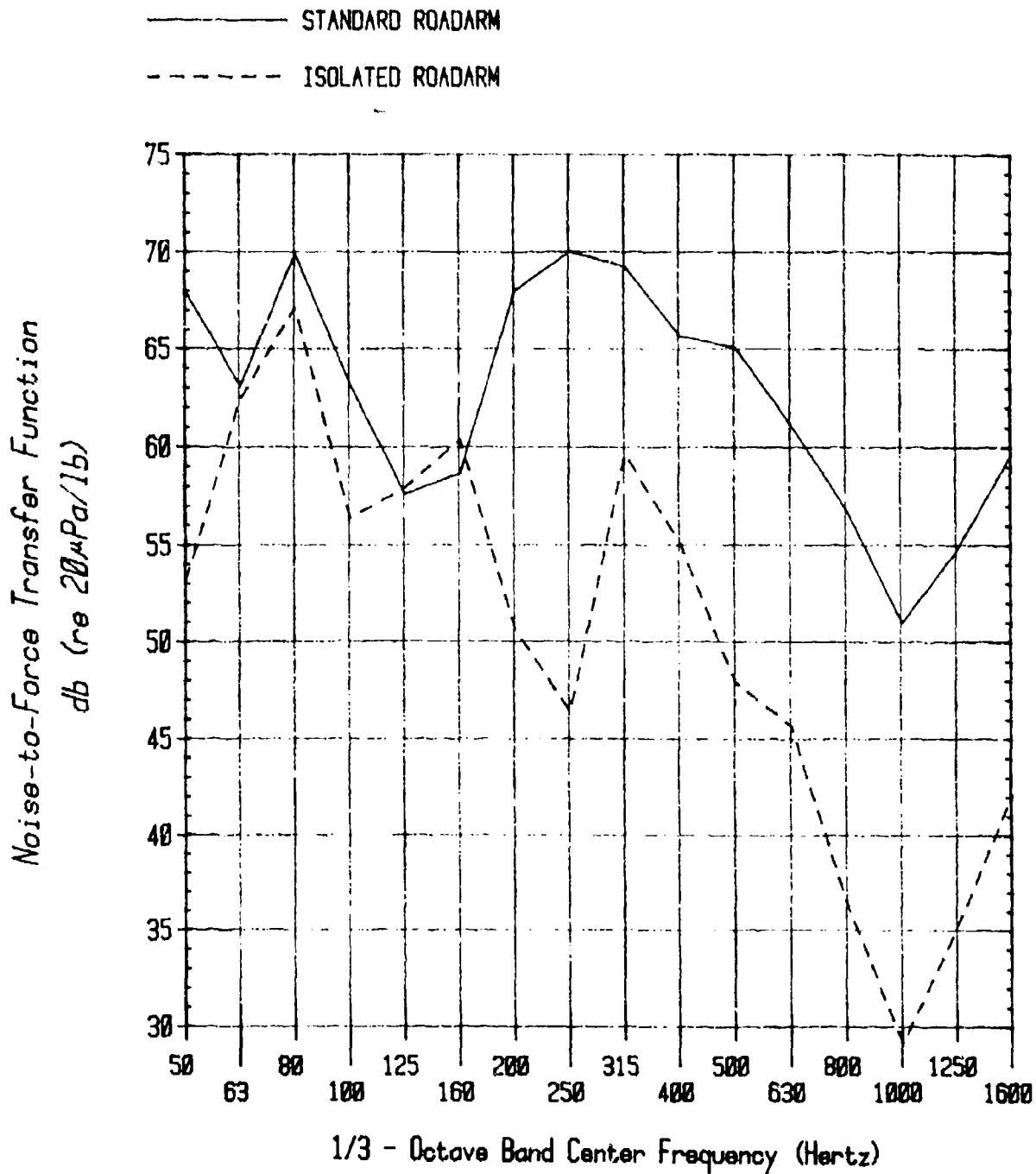

Figure 5.2 Noise-to-Force Transfer Function with the Force Input in the Transverse Direction.

Figure 5.3 for both the horizontal and vertical directions. The uncertainty in these values is discussed in Section 6, Interpretation and Assessment of Data.

5.2 Exterior Noise (Acoustic Signature)

The reduction in acoustic signature (exterior noise) is derived by a calculation technique in Section 6.2. There are no measured exterior noise test results for discussion here.

6. INTERPRETATION AND ASSESSMENT OF NOISE REDUCTION DATA

6.1 Interior Noise Reduction

The roadarm noise reduction measured for the isolated roadarm exceeded all of the 1/3-octave band noise reduction goals above 160 Hz. The following are possible reasons why the required noise reduction was not achieved in the lower frequencies (160 Hz and lower):

- o The rubber mounts which were used in the experimental isolated roadarm tests had a higher spring rate than the optimum of 10,000 lb/in. This caused the isolated roadarm resonant frequency to increase, which reduced or eliminated noise reduction in the low frequency 1/3-octave bands.
- o The low frequency 1/3-octave band insertion loss measurements may not be very accurate. It was discovered in the latter stages of the isolated roadarm tests that the exact microphone position in the crew compartment is critical in the low frequency noise measurements because the sound pressure level in the 50 through 160 Hz 1/3-octave bands is dominated by hull cavity resonances. The wavelength of these resonances is such that a difference in microphone position of just a few inches between subsequent tests, can account for a 3 to 7 dB variation in the low frequency 1/3-octave band levels, particularly near the center where nodes exist. The exact microphone position was not measured for the baseline or standard roadarm tests. The placement of the microphone in the isolated roadarm tests, consequently, may have deviated from the baseline test position by a few inches.

6.2 Acoustic Signature (Exterior Noise) Reduction

The exterior signature of the roadarms and roadwheels consists of two components: noise emitted due to hull vibration, and noise emitted directly from the roadarms and roadwheels. Noise caused by hull vibration has a spectrum shape similar to interior noise and is relieved dominant at and below 1,000 Hz, where it is likely to lead to acoustic detection at a distance. Direct suspension-radiated noise, on the other hand, includes squeaks, clattering sounds and rubbing sounds caused by metal-to-metal contact which are not likely to lead to aural detection at great distances.

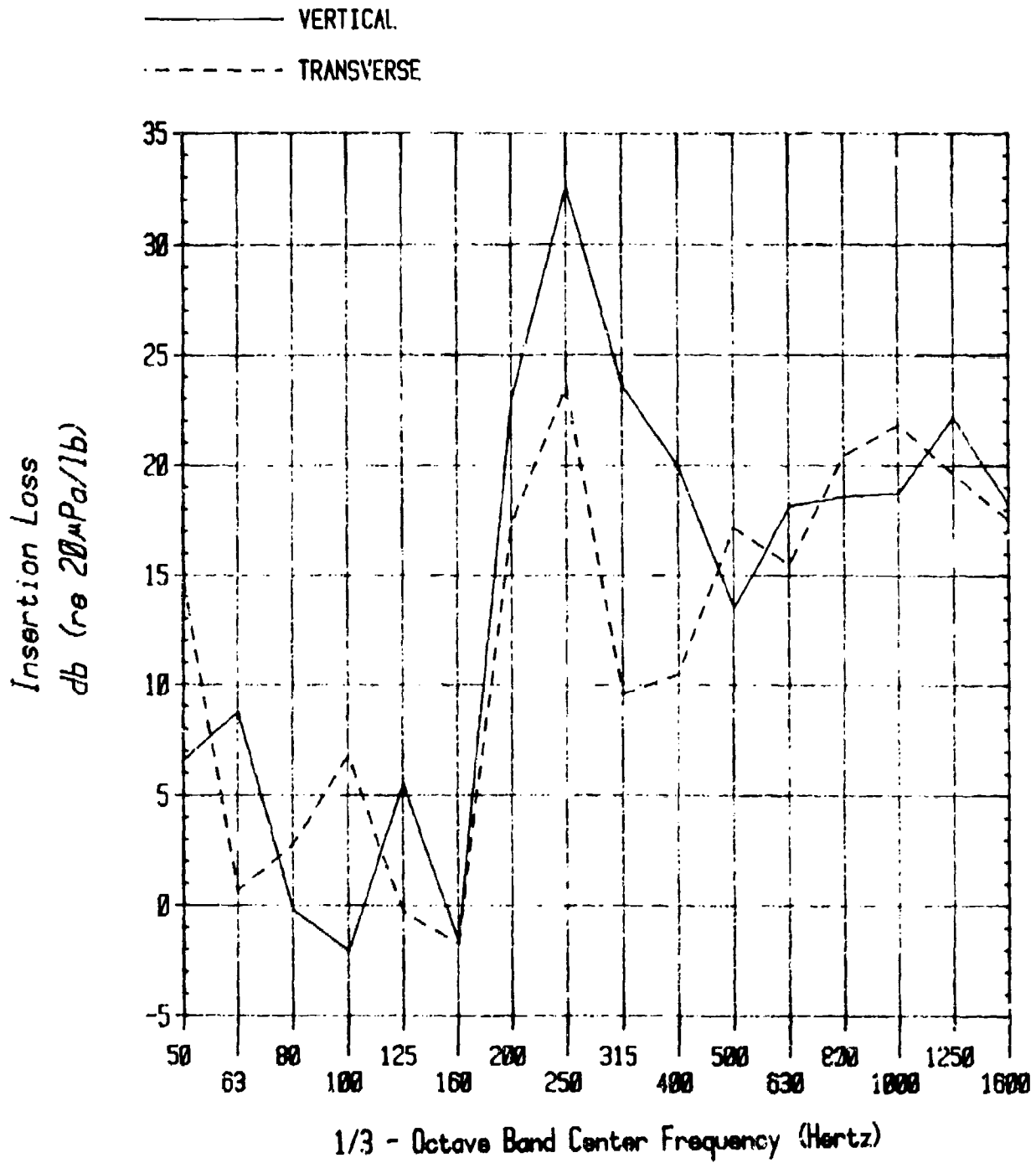

Figure 5.3 Insertion Loss at the Experimental Isolated Roadarm

It was not practical to simply measure exterior noise reductions directly because of interfering noises, both from the electrodynamic shaker and environmental noise sources, such as the nearby highway and airport. Therefore, the following technique was selected, which only allows evaluation of the dominant hull-radiated acoustic signature.

The low frequency exterior noise reduction was estimated by a calculation technique based on interior noise changes. This technique utilized exterior noise data measured while the vehicle was towed at 10 and 20 mph without the idlers and the sprockets with the track wrapped around the roadwheels [4] and data providing the estimated difference between hull-generated interior noise and exterior noise at 25 feet [11]. Using this exterior noise as a baseline, this technique used differences in interior hull-radiated noise to estimate differences in exterior hull-radiated noise. Thus the interior noise insertion loss provided by the compliant mounts, subtracted from the hull-radiated exterior noise data for 25 feet, estimated the exterior noise contribution of hull generated roadarm/roadwheel dependent noise (see Table 6.1).

| 20 mph | 63 Hz | 125 | 250 | 500 | 1K | 2K |
|---|-------|-----|-----|-----|-----|-----|
| 1) 20 mph interior roadarm noise data [4] | 113 | 117 | 108 | 102 | 92 | 87 |
| 2) Less difference between interior and exterior noise [11] | -20 | -20 | -23 | -22 | -22 | -19 |
| 3) Gives Std. M113 roadarm noise at 25 ft. | 93 | 92 | 85 | 80 | 72 | 68 |
| 4) Less measured compliant roadarm mount insertion loss | -4 | -0 | -17 | -15 | -19 | -20 |
| 5) Estimated hull-radiated signature at 25 ft to side, 20 mph for compliant roadarms | 89 | 92 | 68 | 65 | 53 | 48 |
| 10 mph | 63 Hz | 125 | 250 | 500 | 1K | 2K |
| 6) 10 mph interior roadarm noise data [4] | 103 | 102 | 100 | 93 | 87 | 82 |
| 7) Less line 2 above | -20 | -20 | -23 | -22 | -22 | -19 |
| 8) Std. M113 hull-radiated noise at 25 ft. | 83 | 82 | 77 | 71 | 65 | 63 |
| 9) Less line 4 above | -4 | -0 | -17 | -15 | -19 | -20 |
| 10) Estimated hull-radiated signature at 25 ft to side, 10 mph for compliant roadarms | 79 | 82 | 60 | 56 | 46 | 53 |

Table 6.1 Calculation of Estimated Octave Band Hull-Radiated Acoustic Signature for M113 Roadarm-Induced Noise at 25 Feet to Side for Experimental Compliant and Standard Roadarms at 10 and 20 Miles Per Hour.

Figure 6.1 shows estimated octave band spectra of the hull-radiated roadarm-induced acoustic signatures for the M113 vehicle with the standard and vibration isolated roadarm mounts. The estimated signature represents all 10 roadarms at 20 mph. Also shown are engine and exhaust spectra for the standard M113A1 and a demonstration low-signature M113A1 operated by US TACOM.

The roadarm hull-radiated noise is primarily in the 63, 125, and 250 Hz octave bands for the standard M113, and primarily the 125 Hz octave for the vehicle with compliant roadarm mounts. The 125 Hz octave band dominates because of the poor insertion loss at that frequency.

Considering the distance to inaudibility, at 20 mph and probably higher speeds, the engine and exhaust acoustic signature is higher than the standard roadarm-induced signature in all octave bands. Therefore, reducing roadarm-induced noise will have no effect on the distance to inaudibility because engine noise will remain dominant for a standard exhaust. On the other hand, noise produced by TACOM's low-signature vehicle is about equal to the standard roadarm generated noise, and higher than the quieted roadarm generated noise at most frequencies (see Figure 6.1). Therefore, reducing the noise of the idler and the sprocket in addition to that of the roadwheels would probably reduce vehicle detection distance.

Although no data exist for 30 to 40 mph, an extrapolation is that the roadarm noise is at least 10 dB higher at 30 mph, compared to 20 mph [4]. Therefore, at 30 and 40 mph, the distance to inaudibility should be significantly decreased for TACOM's low acoustic signature M113A1 if the compliant roadarms were installed and if the idler and sprocket noise were also reduced.

The acoustic signatures estimated in this section are believed to be accurate within approximately 6 dB. The signature reduction estimates are limited by the accuracy of the interior noise insertion loss information upon which the calculations are based.

7. CONCLUSIONS AND RECOMMENDATIONS

The experimental isolated roadarm demonstrated a substantial reduction in the roadwheel-generated interior noise. All of the 1/3-octave band roadwheel noise reduction goals were met or exceeded except in the 125 and 160 Hz 1/3-octave bands. Although no direct measurement of roadwheel dependent noise levels of the isolated roadarm design in actual vehicle operation was possible, using the measured insertion loss of the isolated roadarm it is estimated that the experimental isolated roadarms would produce a crew area noise level of 100 dB(A) at 30 mph. Improvements planned for the prototype isolated roadarm should meet the design goal of 95 dB(A) roadwheel dependent interior noise.

ROADARM-INDUCED, HULL-RADIATED ACOUSTIC SIGNATURE

- A - - - - Ten standard roadarms, 20 mph
- B - - - - Ten experimental compliant roadarms, estimated signature, 20 mph

ENGINE EXHAUST NOISE

- C - - - - Maximum noise levels in 2-3 gear, 600 to 2000 RPM, accelerator fully depressed, brakes "on", standard M113A1 production vehicle.
- D - - - - Same, but for TARADCOM low-signature demonstration M113A1 vehicle. (Data taken at 50 feet, 6 dB then added for distance compensation)

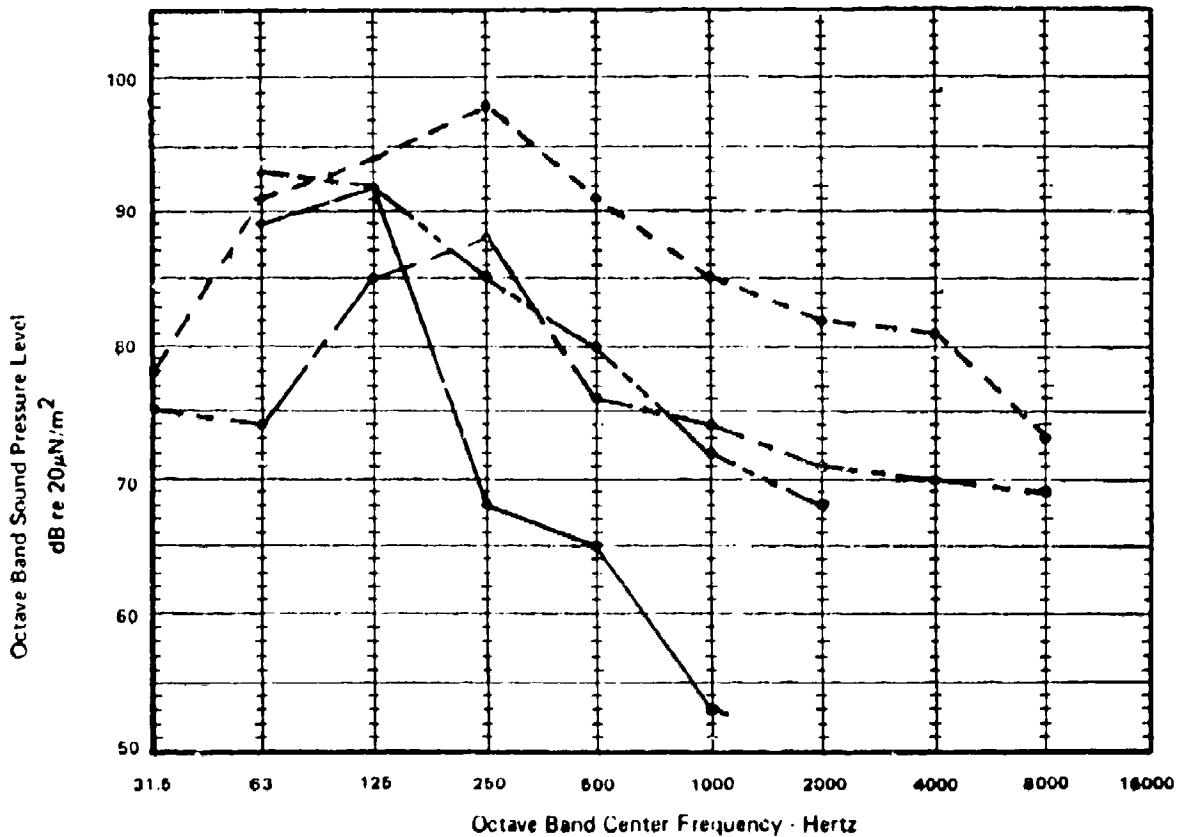

Figure 6.1 Estimated Exterior Signature Spectra of M113 with Ten Standard Roadarms, Experimental Compliant Roadarms and M113A1 Exhaust at 25 Feet to the Left of the Hull

Recommended changes to the experimental roadarm for the prototype work include:

- a. Reduce the isolator spring rate from 21,000 lb/in to as close to 10,000 lb/in as is practical.
- b. Connect the roadarms opposite each other together to react the moments generated by the roadarms into vertical forces at the isolation mounts.
- c. Incorporate a water seal into the isolation mount design.
- d. Provide a means of torsion bar anchor such that the anchor is isolated from the hull.
- e. Toughen the design to provide more durability.
- f. Incorporate a more practical isolator design with components built into the box beam, thereby providing greater mounting stiffness to the isolator.
- g. Consider a design with possible direct interchangeability for existing vehicles.

REFERENCES

1. Hare, R.B.: "APC M113A1 Interior Noise Level With Foam/Barrier/Foam Acoustical Treatment". Technical Report 2408, FMC Corporation, San Jose, CA, May 1972.
2. Norris, T.R.: "MICV Interior Noise Reduction Study". BBN Project No. 164199, Canoga Park, CA. Prepared for FMC Corporation, San Jose, CA, June 1977.
3. Anatrol Corporation: "Interior Noise Control of the M113A1 Armored Personnel Carrier by Hull Damping". Anatrol Project No. 78067, Cincinnati, OH. Prepared for FMC Corporation, San Jose, CA, November 1979.
4. Norris, T.R., Hare, R.B., Galaitsis, A.G., & Garinther, G.R.: "Development of Advanced Concepts for Noise Reduction in Tracked Vehicles". Technical Memorandum 25-77, US Army Human Engineering Laboratory, Aberdeen Proving Ground, MD, August 1977.
5. Norris, T.R., Rentz, P.E., Galaitsis, A.G., Hare, R.B., Hammond, S.A., Garinther, G.R.: "Experimental Idler Design and Development of Hull Concepts for Noise Reduction in Tracked Vehicles". Technical Memorandum 8-79, U.S. Army Human Engineering Laboratory, Aberdeen Proving Ground, MD, June 1979.
6. Hammond, S.A., Aspelund, C.A., Rennison, D.C., Norris, T.R. & Garinther, G.R.: "Experimental Quiet Sprocket Design and Noise Reduction in Tracked Vehicles". Technical Memorandum 8-81, U.S. Army Human Engineering Laboratory, Aberdeen Proving Ground, MD, April 1981.
7. Department of Defense: "Military Standard Noise Limits for Army Materiel". MIL-STD-1474B(MI), Washington, DC 20301. (Obtain from the Naval Publications and Forms Center, 5801 Tabor Avenue, Philadelphia, PA 19120). June 1979
8. Goodyear Tire & Rubber Company: Handbook of Molded and Extruded Rubber. (3rd ed.). Akron, Ohio 44316. 1969
9. Ungar, E.E. & Dietrich, C.W.: "High-Frequency Vibration Isolation". Journal of Sound and Vibration. April 1966, Volume 4, Part 2, Page 224.
10. Rennison, D.C.: "An Experimental Comparison of the Hull Dynamics of the AIFV and M113A1 Tracked Vehicles". BBN Technical Note 09234-1, Canoga Park, CA. Prepared for FMC Corporation, San Jose, CA, January 1980.
11. Norris, T.R., CIEA Progress Report No. 6 to FMC dated May 14, 1979, FMC P.O. No. 197-VI, Contract DAAK11-78-C-0131.
12. Norris, T.R., "Reduced Acoustic Signature Light Tracked Vehicle: Design and Demonstration". TARADCOM R&D Laboratory Technical Report No. 12411, U.S. Army Tank-Automotive Research and Development Command, Warren, MI. September 1978

PREVIOUS NOISE REDUCTION STUDIES

Essentially three methods exist for reducing tracked vehicle interior noise.

1. Reduce the noise and vibration at the source.
2. Modify the noise and vibration transmission paths from the source to the vehicle interior.
3. Absorb the noise in the hull cavity to prevent reverberant buildup.

Studies conducted prior to HEL's initiation of the present work [1 and 2] investigated the use of sound absorbers and acoustic barriers placed on the interior walls of a vehicle to reduce noise. It was found that given constraints of acceptable interior volume reduction and available areas to apply barriers and absorbers, the vehicle noise could not be reduced to meet the requirements of MIL-STD-1474B.

Another study [3] investigated the use of increased structural damping of the hull to reduce its resonant response and thus reduce interior noise. Results of that research showed that practical increases in damping produced only a slight reduction in interior noise.

The HEL and TACOM sponsored studies prior to the present roadarm work, concentrated on reducing the noise and vibration sources and modifying the transmission paths. Only suspension noise sources were considered in these studies. Other noise sources such as the engine, power train and final drive gearing have been shown to be secondary sources [4].

The most important conclusions obtained from this research were:

1. The technology to reduce tracked vehicle noise does not exist and will require development.
2. Very careful control of testing parameters is necessary to accurately measure the incremental noise reductions obtained when evaluating potential noise reduction methods.
3. At and below 20 mph, both idler and sprocket noise must be reduced to meet the noise reduction goals.
4. Above 20 mph, roadwheel noise also must be controlled in addition to idler and sprocket noise.

5. Engine and power train noise is not significant compared to suspension induced noise.
6. Vehicle interior sound absorptive treatments are not practical.
7. Making the idler and sprocket wheel rims more compliant is an effective noise reduction technique.
8. The best spring material for compliant idlers and sprockets appears to be either natural or synthetic base "natural" rubber. Steel springs would be difficult to engineer into the limited space available.
9. Elastomers must be carefully evaluated when considered for use as spring materials in order to select those with optimum mechanical and damping properties.
10. In a compliant idler wheel, axial as well as radial and tangential compliance need to be investigated.
11. Local stiffening of the hull at the roadarm and idler locations provided no significant changes to the mechanical impedances and, therefore, no noise reduction potential.
12. A damping treatment applied to both sponsons provided appreciable sponson vibration reduction at 500 Hz and higher frequencies. This treatment also gave a modest vibration reduction of other hull plates and noise reduction of approximately 0-2 dB(A).
13. To achieve noise reduction by means of hull plate damping, a promising technique of constrained layer damping was found to be much less effective than initially expected.
14. The computerized simulation of track dynamics, while producing promising results, would require incremental refinement before it should be used in designing lower noise suspension components.
15. A compliant prototype idler wheel was designed and fabricated which was not only rugged and practical but also demonstrated a 15 dB(A) reduction in interior noise level compared to the standard idler wheel.
16. A compliant experimental sprocket was designed, fabricated, and tested. Measurements indicated that it was 7-8 dB(A) quieter than the standard sprocket, while maintaining full torque carrying capacity. Further evaluation showed that an improved design could produce greater attenuation.

17. Statistical energy flow analysis of vibratory power accepted by the vehicle hull and the idler attachment transfer function analysis do not in themselves provide enough information to identify possible modifications in the vehicle hull which could result in lower interior noise levels.
18. Preliminary results of interior noise level prediction based on finite element analysis data were encouraging and showed reasonable agreement between measured data and predicted results. However, a very accurate finite element model will be required to evaluate hull modifications to see if they produce lower interior noise levels.

ROADARM NOISE-TO-FORCE TRANSFER FUNCTION DATA

| 1/3-Octave Band Center Frequency (Hertz) | Noise-to-Force Transfer Function (dB re 20 μ Pa) | |
|--|---|---------------------|
| | Standard Roadarm | Isolated Roadarm |
| 50 | 67.7 | 61.1 |
| 63 | 58.9 | 50.1 |
| 80 | 58.4 | 58.6 |
| 100 | 50.1 | 52.1 |
| 125 | 51.7 | 46.1 |
| 160 | 48.0 | 49.6 |
| 200 | 61.4 | 38.4 |
| 250 | 70.2 | 37.6 |
| 315 | 68.5 | 44.9 |
| 400 | 62.3 | 42.4 |
| 500 | 64.4 | 50.9 |
| 630 | 60.1 | 41.9 |
| 800 | 54.0 | 35.4 |
| 1000 | 53.7 | 34.9 |
| 1250 | 58.3 | 36.1 |
| 1600 | 60.1 | 41.9 |

Note: Force input is in the vertical direction.

ROADARM NOISE-TO-FORCE TRANSFER FUNCTION DATA

| 1/3-Octave Band Center Frequency (Hertz) | Noise-to-Force Transfer Function (dB re 20 μ Pa) | |
|--|---|---------------------|
| | Standard Roadarm | Isolated Roadarm |
| 50 | 67.9 | 53.1 |
| 63 | 63.1 | 62.4 |
| 80 | 69.9 | 67.1 |
| 100 | 63.2 | 56.4 |
| 125 | 57.6 | 57.9 |
| 160 | 58.6 | 60.4 |
| 200 | 68.0 | 50.6 |
| 250 | 69.0 | 46.8 |
| 315 | 69.2 | 59.6 |
| 400 | 65.6 | 55.1 |
| 500 | 55.1 | 47.9 |
| 630 | 61.1 | 45.6 |
| 800 | 56.8 | 36.4 |
| 1000 | 51.0 | 29.1 |
| 1250 | 54.7 | 35.1 |
| 1600 | 59.6 | 42.1 |

Note: Force input is in the transverse direction.