

AD-A145 466

LABORATORY EVALUATION OF ELECTROMAGNETIC PULSE (EMP)
HARDNESS TESTING CON. (U) CONSTRUCTION ENGINEERING
RESEARCH LAB (ARMY) CHAMPAIGN IL P H NIELSEN AUG 84
CERL-TR-M-350

1/1

UNCLASSIFIED

F/G 20/14

NL

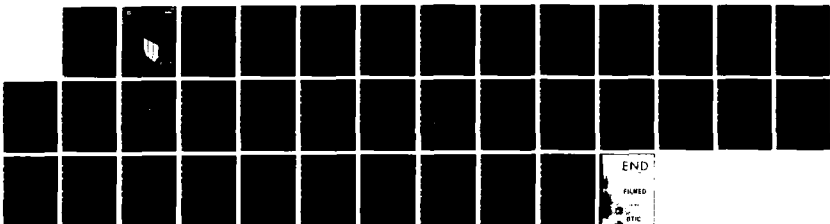

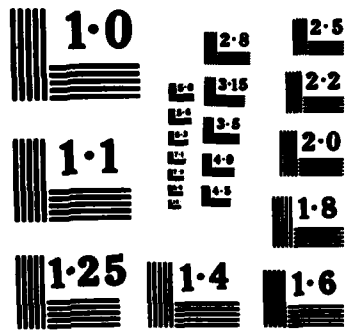



**US Army Corps
of Engineers**
Construction Engineering
Research Laboratory

CEERL

TECHNICAL REPORT M-350
August 1984

AD-A145 466

**LABORATORY EVALUATION OF ELECTROMAGNETIC
PULSE (EMP) HARDNESS TESTING CONCEPTS
FOR ELECTRICAL CONDUIT SYSTEMS**

by
Paul H. Nielsen

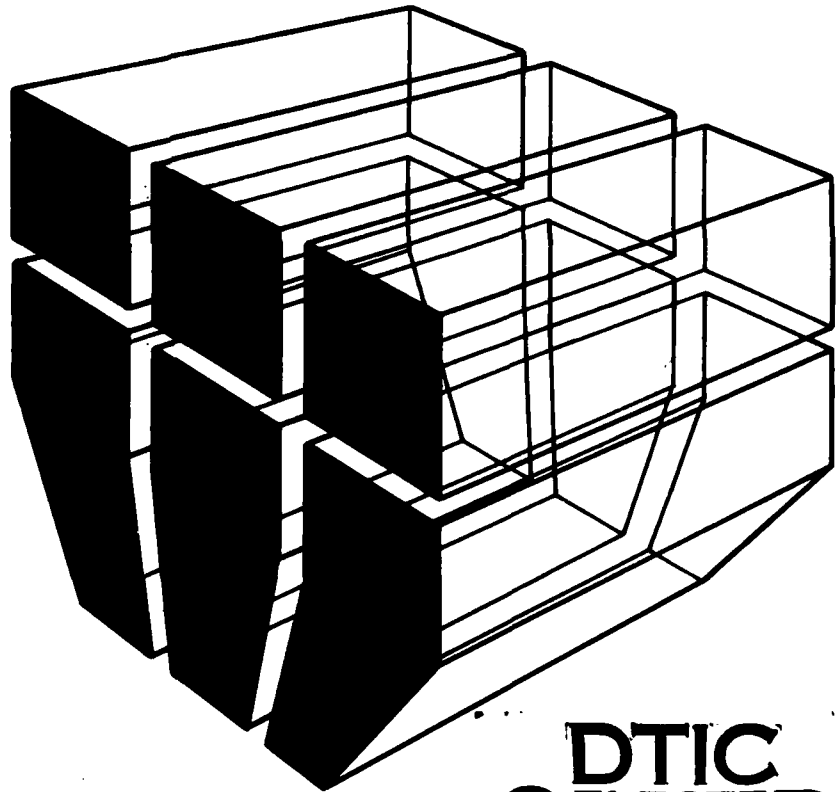

DTIC FILE COPY

DTIC
ELECTE
SEP 12 1984
S **D**

Approved for public release; distribution unlimited.

84 09 10 008

The contents of this report are not to be used for advertising, publication, or promotional purposes. Citation of trade names does not constitute an official indorsement or approval of the use of such commercial products. The findings of this report are not to be construed as an official Department of the Army position, unless so designated by other authorized documents.

***DESTROY THIS REPORT WHEN IT IS NO LONGER NEEDED
DO NOT RETURN IT TO THE ORIGINATOR***

UNCLASSIFIED

SECURITY CLASSIFICATION OF THIS PAGE (When Data Entered)

REPORT DOCUMENTATION PAGE		READ INSTRUCTIONS BEFORE COMPLETING FORM
1. REPORT NUMBER CERL-TR-M-350	2. GOVT ACCESSION NO. AD-A145466	3. RECIPIENT'S CATALOG NUMBER
4. TITLE (and Subtitle) LABORATORY EVALUATION OF ELECTROMAGNETIC PULSE (EMP) HARDNESS TESTING CONCEPTS FOR ELECTRICAL CONDUIT SYSTEMS	5. TYPE OF REPORT & PERIOD COVERED Final	
	6. PERFORMING ORG. REPORT NUMBER	
7. AUTHOR(s) Paul H. Nielsen	8. CONTRACT OR GRANT NUMBER(s) DNA Reimbursable Order 82577	
9. PERFORMING ORGANIZATION NAME AND ADDRESS U.S. ARMY CONSTRUCTION ENGINEERING RESEARCH LABORATORY P.O. BOX 4005, CHAMPAIGN, IL 61820	10. PROGRAM ELEMENT, PROJECT, TASK AREA & WORK UNIT NUMBERS	
11. CONTROLLING OFFICE NAME AND ADDRESS Defense Nuclear Agency Hybla Valley Federal Bldg., 6801 Telegraph Rd. Washington, DC 20305	12. REPORT DATE August 1984	
	13. NUMBER OF PAGES 32	
14. MONITORING AGENCY NAME & ADDRESS (if different from Controlling Office)	15. SECURITY CLASS. (of this report) Unclassified	
	15a. DECLASSIFICATION/DOWNGRADING SCHEDULE	
16. DISTRIBUTION STATEMENT (of this Report) Approved for public release; distribution unlimited.		
17. DISTRIBUTION STATEMENT (of the abstract entered in Block 20, if different from Report)		
18. SUPPLEMENTARY NOTES Copies are available from the National Technical Information Service Springfield, VA 22161		
19. KEY WORDS (Continue on reverse side if necessary and identify by block number) electric conduits electromagnetic shielding		
20. ABSTRACT (Continue on reverse side if necessary and identify by block number) Four concepts were evaluated for potential use in testing the shielding integrity of metal conduits: the Hall effect, standing wave coupling, micro-wave resonant cavity, and diffusion current-leakage current comparison. Existing technology for hardness verification and defect location was reviewed for comparison with the new methods. <i>electromagnetic</i>		

(Continued on next page)

BLOCK 20 (Cont'd)

Because of the phenomena involved, the four concepts are mainly for use with nonburied conduits. In addition, each method has its prospective application limited by one or more drawbacks to implementation: ~~the~~ Hall effect devices require direct access to the conduit system and are subject to geometry-dependent variables; with standing wave coupling tests, it may be difficult to maintain a transmission line configuration for the conduit system; the microwave resonant cavity method also requires direct access to the conduit and its greatest potential is for testing of specific conduit components; low-frequency phase comparison only verifies hardness, so defects must be located by another test.

None of the new methods can be recommended without further development and field evaluation.



FOREWORD

This work was performed by the Engineering and Materials (EM) Division of the U.S. Army Construction Engineering Research Laboratory (CERL) for the Defense Nuclear Agency (DNA) under DNA Reimbursable Order 82577 dated 1982.

Some of the data in this report were published in CERL Technical Report M-292/AD-A107133, EMP/EMI Hardening of Electrical Conduit Systems, September 1981. Additional analytic efforts conducted since then are reported here.

Dr. Robert Quattrone is Chief of CERL-EM. COL Paul J. Theuer is Commander and Director of CERL, and Dr. L. R. Shaffer is Technical Director.

Accession For	
NTIS GRA&I	<input checked="" type="checkbox"/>
DTIC TAB	<input type="checkbox"/>
Unannounced	<input type="checkbox"/>
Justification	
By _____	
Distribution/	
Availability Codes	
Dist	Avail and/or Special
A-1	



CONTENTS

	<u>Page</u>
DD FORM 1473	1
FOREWORD	3
LIST OF TABLES AND FIGURES	5
1 INTRODUCTION.....	7
Background	
Objective	
Approach	
2 REVIEW OF EXISTING TESTS.....	8
Test Concept	
Air Leak/Pressurization Test	
Pulsed Transmission Line Test	
Pulsed Dipole Test	
Visual Inspection	
3 LABORATORY TESTS OF NEW CONCEPTS.....	11
Hall Effect Device	
Standing Wave Coupling	
Microwave Resonant Cavity	
Diffusion Current-Leakage Phase Comparison	
Analysis of Results	
Field Use of New Methods	
4 CONCLUSIONS AND RECOMMENDATIONS.....	32
REFERENCES	32
DISTRIBUTION	

TABLES

<u>Number</u>		<u>Page</u>
1	Measurements With Model FH-302-040 Hall Effect Device at 15-mA Hall Current, 20-A Conduit Current (in mV)	15
2	Measurements With Model FH-302-040 Hall Effect Device at 15-mA Hall Current, 20-A Conduit Current (mV, Normalized to Lowest Reading)	15
3	Measurements With Model BH-700 Hall Effect Device, 200-mA Hall Current, 20-A Conduit Current (in mV)	16
4	Measurements With Model BH-700 Hall Effect Device at 200-mA Hall Current, 20-A Conduit Current (in mV, Normalized to Lowest Reading)	16
5	Conductivities (σ) of Earth Materials at Normal Temperatures and Pressures	21
6	Skin Depth (δ) in Earth Materials of Various Conductivities (in meters)	23
7	Diffusion Current Phase Lag for 1-in. Rigid-Walled Steel Conduit (Wall Thickness= $.338 \times 10^{-2}$ m)	29
8	Diffusion Current Phase Lag for 1-in. Rigid-Walled Aluminum Conduit	29
9	Estimated Frequencies at Which Rigid-Walled Steel Conduit Is One Wavelength Thick	30

FIGURES

1	EMP Coupling Through Electrical Conduit	8
2	Magnetic Field Associated With a Current Flow	12
3	Current Flow Around a Transverse Defect	12
4	Hall Effect Device Used to Measure a Magnetic Field	13
5	Proposed Conduit Test Fixture Using Hall Effect Devices	13
6	Grid for Data Points Measuring Magnetic Field Distortion by a Conduit Defect	14
7	Standing Wave Pattern and Test Configuration	18
8	Magnitude of Coupled Signal Versus Frequency for a Defect 10 Ft From the Signal Source	19

FIGURES (Cont'd)

<u>Number</u>		<u>Page</u>
9	Magnitude of Coupled Signal Versus Frequency for a Defect 4 Ft From the Signal Source	19
10	Wavelength of Electromagnetic Waves in Lossy Media	23
11	Microwave Resonant Cavity Test Fixture	24
12	Alternate Resonant Cavity Design	24
13	Phase Delay of a Signal Propagating Through a Metal Slab, and Test Configuration Used	28

LABORATORY EVALUATION OF ELECTROMAGNETIC
PULSE (EMP) HARDNESS TESTING CONCEPTS
FOR ELECTRICAL CONDUIT SYSTEMS

1 INTRODUCTION

Background

Metal conduits can provide significant electromagnetic pulse (EMP) protection for electrical conductors (electrical power and signal cables). The proper choice of components and correct assembly of the conduit systems usually provide adequate shielding from EMP currents; however, defects, improper assembly, incorrect hardware, or serious defects in a welded system can seriously degrade such shielding. Thus, verification of the shielding integrity and location of defects in conduit systems are important considerations for facility acceptance testing and hardness assessment.

The conduit systems of concern are essentially extensions of shielded zones of fixed facilities. Thus, the conduit systems usually are external to shielded volumes. These conduits may be buried in the earth, routed through unshielded structures, or installed above ground outside the structure. In general, access to the conduits is difficult, especially after construction is completed.

Long conductor runs are prime candidates for large induced EMP currents. Such currents carried by conduits can be coupled to internal conductors by diffusion through the conduit wall or by direct coupling through apertures in the conduit. Shielding from diffusion currents is mainly a function of the conduit wall thickness, its electrical conductivity, and its magnetic permeability. Shielding from direct coupling is possible by avoiding any deliberate or unintentional apertures or high-resistance joints in the conduit system.

Objective

The objective of this study was to identify and evaluate techniques for assessing the EMP hardness of electrical conduits used for EMP shielding.

Approach

Existing conduit test techniques were reviewed. Other pipe and cable tests were then examined to determine their usefulness as electrical conduit tests. These test techniques involve measurements of physical phenomena, which can be related to a conduit's shielding performance. Additional electromagnetic phenomena were investigated for possible development of new test techniques. An earlier CERL technical report¹ provided a database for comparing these phenomena.

¹P. Nielsen, EMP/EMI Hardening of Electrical Conduit Systems, TR M-292/ADA107133 (CERL, 1981).

2 REVIEW OF EXISTING TESTS

Test Concept

A conduit system's response to a conducted EMP can be analyzed with reference to Figure 1. For a uniform defect-free conduit with a pulse excitation, most of the current, especially the high-frequency components, will flow on the outer surface of the conduit as a result of skin effect phenomena. A portion of the current will, however, propagate through the metal and produce an electromagnetic field inside the conduit. This is the diffusion current which is attenuated exponentially with distance through the metal, with higher frequencies subject to greater attenuation. Presence of a defect or resistive section in the conduit will induce currents on internal conductors by mutual inductance (flux linkage) or by resistive voltage division between the conduit and internal conductor.

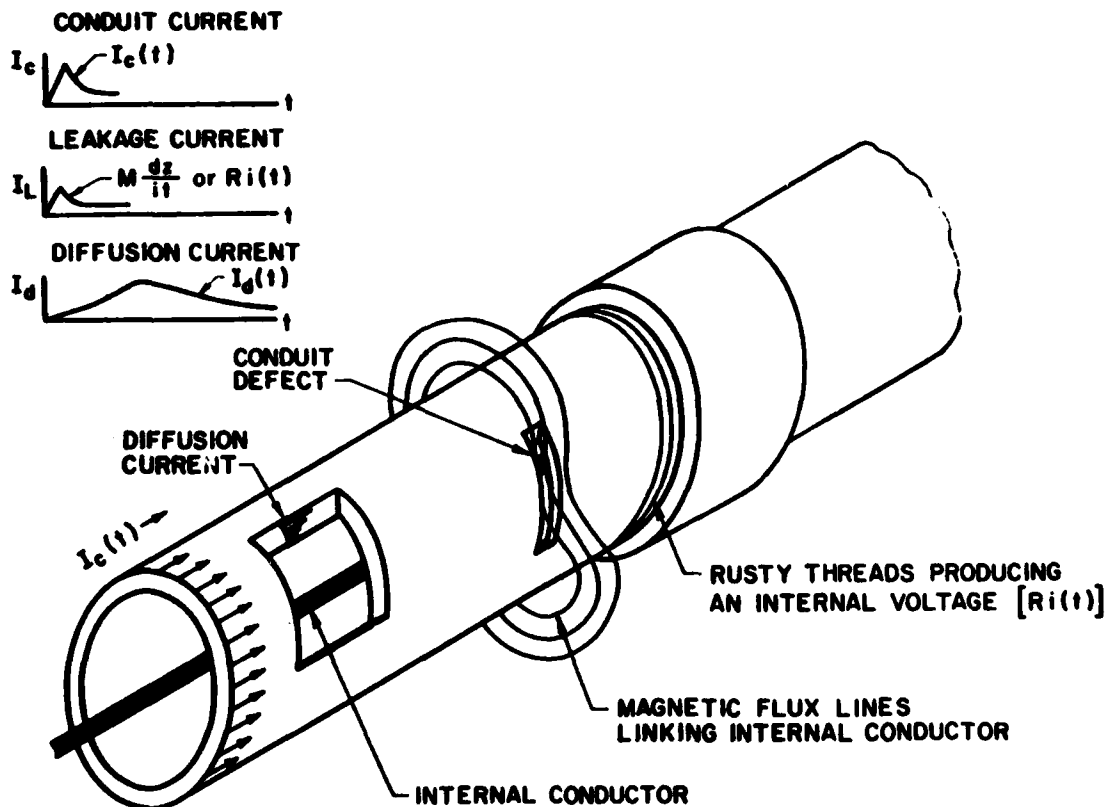

Figure 1. EMP coupling through electrical conduit.

Examples of possible conduit defects include: broken or misaligned unions, partial breaks, broken or loose couplings, conduit broken at threads, rusty threads, or a faulty weld on a welded conduit. Ideally, an EMP hardness verification test should be able to locate any of these defects.

EMP hardness testing involves measuring some physical property of the conduit system and relating that property to the conduit's shielding integrity. For example, one possible test is a radiated threat level EMP. However, if a radiated EMP is not part of the overall facility acceptance test, it will not be economically practical to do it to determine conduit system hardness. Full-scale facility testing also has limited use in conduit defect location; the existence of a defect may be determined, but no means for locating the leak is inherent in the test.

The four existing methods reviewed were (1) air leak/pressurization, (2) pulsed transmission line, (3) pulsed dipole (PLACER, which actually stands for Pulsed Loop Antenna Conduit Electromagnetic Radiator), and (4) visual inspection. Of these tests, the PLACER was identified as an optimal technique for investigating the shielding integrity of buried conduits.

Air Leak/Pressurization Test

Buried conduits at the Safeguard Ballistic Missile Defense System were examined using air leak, pulsed transmission line, and pulsed dipole (PLACER) techniques. The air leak or pressurization test was used under the assumption that an EMP leak would coincide with an air leak in the conduit system. This test was useful to the extent that a leaking conduit could be identified in a bank of conduits. Defect location was then completed by inspecting the inside of the conduit with closed circuit television. Television inspection is practical, however, only if no wires have been pulled in the conduit. Moreover, the correlation between air leakage and EMP leakage is subject to debate: it is possible that not every EMP leak will be found this way and that some air leaks are not significant EMP leaks. However, if helium is used for pressurization, the general area of the leak can be determined with sensitive helium detectors.

Pulsed Transmission Line Test

In the pulsed transmission line test,² a buried conduit is directly pulse-excited and a sensing wire inside the conduit is used to determine if a flaw exists. Tests with this system showed limited success because of the lossy nature of the soil in which the transmission line (conduit bank) was buried. Thus, a drawback of this test is its dependence on electrical excitation of the conduit, making it unsuited to any evaluation of buried conduits. Also, this test has no inherent mechanism to locate flaws. It only identifies a defective conduit system.

²H. Roberts, et al., EMP Testing of Buried Conduits, The Pulsed Dipole and Pulsed Transmission Line, AD-A0172991 (Department of the Army [DA], September 1976).

Pulsed Dipole Test

The pulsed dipole test (PLACER)^{3,4} was much more effective in flaw location. A pulse is radiated near the ground from a portable pulse generator above the conduit being tested. Again, a wire inside the conduit is used as a sensing element to measure leakage. Correlation of the portable unit location with signal magnitude provides a reasonably precise location of a flaw and indicates the defect's severity.

The PLACER was relatively successful for defect location in buried conduit systems. It is recommended both for acceptance testing and hardness maintenance testing during the life of a hardened facility. The small diameter wire required for this test can be installed along with any power and signal cables and then left in place for later testing. In general, the PLACER is not very useful for testing conduits inside structures such as buildings and metal-lined tunnels.

Visual Inspection

Although not actually classified as a test, an effective technique for locating potential EMP leaks is thorough visual inspection of the conduit system by knowledgeable individuals. The major items to be noted in such an inspection are that everything is properly assembled and tightened and that no broken hardware is used. The hardware should be clean and rust-free, and any condition that appears to interrupt the system's electrical continuity should be corrected. A complete inspection may not be possible for all systems because of conduit installation in banks or through areas of no access.

³D. L. Goodwin, The PLACER: Assembly and Operation, HDL-TM-77-7 (DA, April 1977).

⁴F. V. Agee and H. A. Roberts, The Development of a Pulsed Loop Antenna Conduit Electromagnetic Radiator (PLACER), HDL-TR 1850 (DA, September 1978).

3 LABORATORY TESTS OF NEW CONCEPTS

CERL devised and evaluated several electronic leak detection and location techniques mainly for use with nonburied conduits. In general, these require access to at least part of the conduit being tested. All measure some electrical property measurement that can be related to the conduit's EMP shielding. The four tests evaluated were: (1) Hall effect, (2) standing wave defect location (3) microwave resonant cavity, and (4) diffusion current-leakage current phase comparison.

In the Hall effect test, the conduit is excited with a lateral current (a.c. or d.c.) and Hall effect devices are used to detect nonuniformities in the current flow.

The standing wave coupling concept can be used for defect location after a standing wave is induced on the outside of the conduit, with the defect location mapped by monitoring the magnitude of the signal appearing on an internal conductor as the frequency of the standing wave is varied. This frequency variation changes the position of voltage peaks and nulls on the conduit.

The third test involves placing a microwave resonant cavity over a suspected defect in the conduit. Leak detection is done by monitoring microwave currents on conductors internal to the conduit or microwave signals propagating in the conduit.

The diffusion current-leakage current phase comparison is based on the principle that a leakage current induced on conductors inside a conduit excited with a low frequency a.c. current will essentially be in phase with the excitation current. The diffusion current will have a phase lag associated with the propagation time through the conduit wall. Thus, with a low frequency excitation, a signal on internal conductors in phase with the applied signal indicates a leak.

Hall Effect Device*

If a current (d.c. or a.c.) is applied to a uniform conductor, such as a defect-free conduit, it will produce an associated uniform magnetic field with flux lines forming concentric circles around the outside of the conduit (Figure 2). If the conduit has a defect, the current flow and the accompanying magnetic field will no longer be uniform (Figure 3). Thus, defects in a conduit system that cause disruptions in a uniform current flow should be detectable by monitoring the magnetic field near a conduit excited by an electric current. This concept is essentially field mapping of the magnetic field surrounding a current-carrying conduit.

*The Hall Effect, S-band resonant cavity, and standing wave test concepts were discussed earlier in a CERL technical report by P. Nielsen, EMP/EMI Hardening of Electrical Conduit Systems, TR M-292/ADA107133 (CERL, 1981). This report reflects additional efforts on the resonant cavity and standing wave tests conducted after the publication of TR M-292.

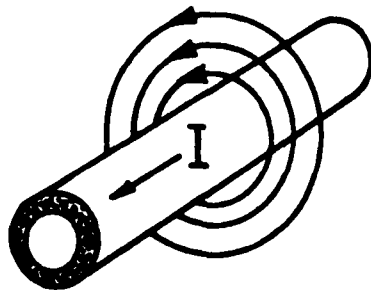

Figure 2. Magnetic field associated with a current flow.

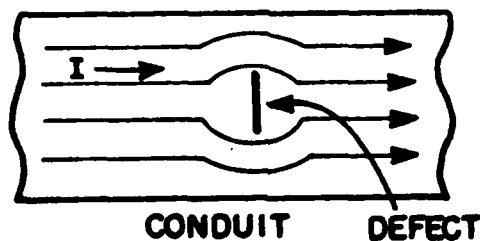

Figure 3. Current flow around a transverse defect.

A Hall effect device is a special semiconductor sensitive to magnetic fields. If a current flows through the device while the device is immersed in a magnetic field, a voltage proportional to that field will appear on the device perpendicular to both the magnetic field and the direction of current flow (Figure 4). Most practical Hall effect devices are flat plates with two current leads and two voltage leads. The output voltage is a maximum when the magnetic field is perpendicular to the flat surface of the device. The excitation current and the magnetic field can be any combination of d.c. and a.c.

CERL conducted a test to determine the technical feasibility of this concept. A proposed fully implemented system would consist of a test fixture composed of several Hall effect devices placed around and perpendicular to a conduit carrying a current (Figure 5). Associated amplification and monitoring electronics would record the measurements. The test fixture is designed to move along the long dimension of the conduit. Readout electronics would consist of a multiplexed system in conjunction with a microprocessor to store and analyze the data.

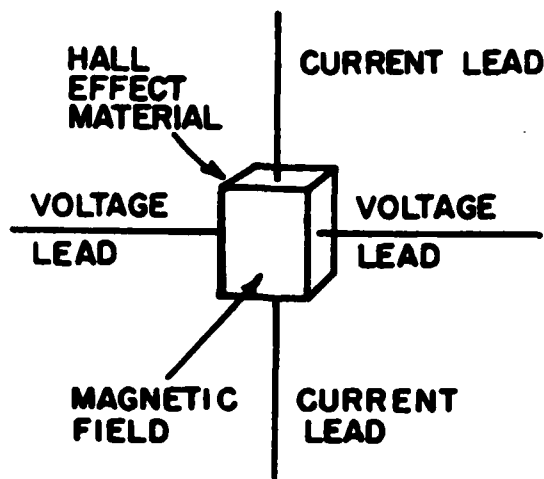

Figure 4. Hall effect device used to measure a magnetic field.

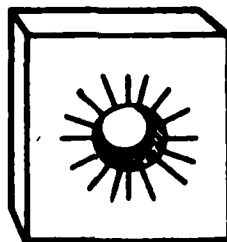

Figure 5. Proposed conduit test fixture using Hall effect devices. (The fixture used at CERL had Hall effect devices mounted in two of the slots.)

A test fixture as shown in Figure 5 was constructed for the CERL in-house evaluation. Sixteen slots were spaced equally around the periphery of a hole in a piece of 1/2-in.-thick phenolic material.* (The mounting material for the Hall effect devices must be nonconducting.) The hole was slightly larger than the outside of a 1-in. rigid-walled steel conduit. Two Hall effect devices with different sensitivities were mounted in this fixture--Models FH-302-040 and BH-700 from F. W. Bell, Inc. The test specimen was a 5-ft section of 1-in. rigid-walled steel conduit with two defects: an 0.8-in. transverse slot (measured end-to-end at the conduit's external surface) and a 1/4-in. diameter round hole. A paper grid with lines every 45 degrees around the conduit and every 3/4 in. along the length of the conduit was placed with its center over the defect (Figure 6). The conduit was excited with d.c. of 20 Amperes. The test fixture was placed with one of the Hall effect devices located over the grid points. The Hall effect voltage was amplified 1000 times by an integrated circuit operational amplifier and was read on a digital voltmeter.

*Metric conversion: 1 inch = 2.54 centimeters; 1 foot = .305 meters; 1 mil = 2.54×10^{-5} meter.

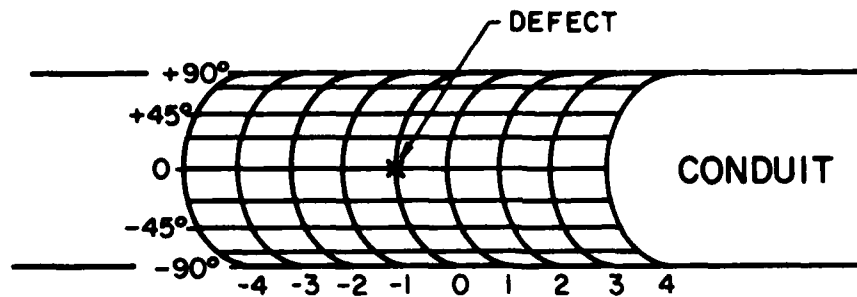

Figure 6. Grid for data points measuring magnetic field distortion by a conduit defect.

The results of these tests are given in Tables 1 through 4. Tables 2 and 4 show the same data normalized to the lowest reading for easier determination of relative magnetic field strength. During preliminary tests, considerable variation in the device output was noted. It was determined that much of this variation was related to the nearness of the conduit to the Hall effect device and also to the magnitude of the current applied to the device. This variation in output was concluded to be a function of the degree of heat sinking provided for the Hall effect device by the conduit. This phenomenon was a problem only with the BH-700 for which a Hall effect current of 200 mA was used versus 15 mA for the FH-302-040. The problem was reduced considerably by taking a reading of the Hall effect voltage with no current applied to the conduit, immediately followed by a reading with 20 A flowing in the conduit. The Hall effect voltage due to the magnetic field is the difference between the two readings.

The data indicate that the particular defects tested produced measurable magnetic field variations; however, unless adequate precautions are taken, this variation can be masked by unrelated factors. For example, the Hall effect devices are very temperature-sensitive and for the BH-700, a very slight change in distance from the conduit can cause a significant change in the Hall effect voltage not related to any magnetic field variation, but to the conduit's heat-sinking effects. Field use of this concept would need to include techniques to eliminate temperature-related offset or d.c. drift problems.

Standing Wave Coupling

If a transmission line terminates in an impedance different from the characteristic impedance of that line, standing waves will occur on the line. The location of the peaks and nodes of these standing waves is a function of the excitation frequency and can be accurately determined theoretically. Such a transmission line could consist of a pair of conduits with one end short-circuited on a shielded structure. In this study, an a.c. signal was injected onto such a system.

Table 1

Measurements With Model FH-302-040 Hall Effect Device at 15-mA Hall Current, 20-A Conduit Current (in mV)

0.8-In. Slot

Location

(Degrees)	-4	-3	-2	-1	0	1	2	3	4
0	42	40	35	37	35	38	39	42	44
45	48	47	47	46	56	51	42	43	47
90	50	50	56	54	53	56	52	50	49
135	51	51	60	56	48	52	55	55	50

1/4-In. Round Hole

Location

(Degrees)	-4	-3	-2	1	0	1	2	3	4
0	47	50	47	43	42	42	40	47	52
45	50	50	52	50	54	54	54	52	51
90	55	57	55	59	59	58	58	56	55

Table 2

Measurements With Model FH-302-040 Hall Effect Device at 15-mA Hall Current, 20-A Conduit Current (in mV, Normalized to Lowest Reading)

0.8-In. Slot

Location

(Degrees)	-4	-3	-2	-1	0	1	2	3	4
0	7	5	0	2	0	3	4	7	9
45	13	12	12	11	21	16	7	8	12
90	15	15	21	19	18	19	17	15	14
135	16	16	25	21	13	17	20	20	15

1/4-In. Round Hole

Location

(Degrees)	-4	-3	-2	-1	0	1	2	3	4
0	10	10	7	3	2	2	0	7	12
45	10	10	12	10	14	14	14	12	11
90	15	17	15	19	19	18	18	16	15

Table 3

Measurements With Model BH-700 Hall Effect Device, 200-mA Hall Current, 20-A Conduit Current (in mV)

0.8-In. Slot

(Degrees)	Location								
	-4	-3	-2	-1	0	1	2	3	4
0	135.5	137.0	131.3	134.0	107.3	139.2	136.9	139.2	136.6
45	132.4	136.9	131.7	142.0	145.4	143.0	126.0	125.9	135.0
90	137.9	139.8	142.8	133.8	139.8	153.1	139.5	128.6	140.4

1/4-In. Round Hole

(Degrees)	Location								
	-4	-3	-2	-1	0	1	2	3	4
0	138.9	139.0	137.4	132.7	138.8	138.5	135.0	137.6	136.0
45	139.0	139.0	138.5	136.5	139.0	134.0	139.0	137.9	136.5

No Defect

(Degrees)	Location								
	-4	-3	-2	-1	0	1	2	3	4
180	138.5	137.0	135.2	137.3	139.0	136.4	138.5	133.3	149.0
225	144.2	134.2	135.6	139.6	132.8	140.5	140.4	130.4	132.4

Table 4

Measurements With Model BH-700 Hall Effect Device at 200-mA Hall Current, 20-A Conduit Current (in mV, Normalized to Lowest Reading)

0.8-In. Slot

(Degrees)	Location								
	-4	-3	-2	-1	0	1	2	3	4
0	28.2	29.7	00	26.7	0	31.9	29.6	31.9	29.3
45	25.1	29.6	24.4	35.6	38.1	35.7	18.7	18.6	27.7
90	30.6	32.5	35.5	26.5	32.5	45.8	32.2	19.3	33.1

1/4-In. Round Hole

(Degrees)	Location								
	-4	-3	-2	-1	0	1	2	3	4
0	6.2	6.3	4.7	0	6.1	5.8	2.3	4.9	3.3
45	6.3	6.3	5.8	3.8	6.3	1.3	6.3	5.2	3.8

No Defect

(Degrees)	Location								
	-4	-3	-2	-1	0	1	2	3	4
180	8.1	6.6	4.8	6.9	8.6	6.0	8.1	2.9	18.6
225	13.8	3.8	5.2	9.2	2.4	10.1	10	0	2

If a conduit has a defect, energy will couple to conductors internal to the conduit. If the frequency of a continuous wave (CW) signal applied to a conduit is varied, with the maximum signal level kept constant, the signal level on a conductor internal to a defective conduit will vary, depending on the magnitude of the standing wave at the point of the defect. Defects can be located by comparing the theoretical location of standing wave peaks and nulls applied to the conduit's outside surface with the signal level on a conductor inside that conduit.

CERL conducted an experiment with a parallel conduit transmission line consisting of two 1/2-in. electrometallic-tubing (EMT) conduits (outside diameter - 0.706 in.) 20 ft long, spaced 2 in. apart. The characteristic impedance of this transmission line using the formula $Z_0 = 120 \ln \frac{2D}{d}$, where D is the center-to-center spacing of the conductors and d is the conductor diameter, is approximately 200 ohms. The 20-ft length was obtained by using two standard 10-ft sections of conduit connected by a standard EMT coupling (Figure 7). The conduits were shorted together at the shielded room end. A 12-gage copper wire was connected to the inside of one of the conduit's end-caps, brought into the shielded room, and connected to the room's inner surface. Existence of the standing wave pattern on the conduit transmission line was verified by monitoring the output of a current probe moved along one of the conduits. The output of the current probe was plotted as a function of location and frequency, as shown in Figure 7.

A defect on the test conduit allows a signal to couple to an internal conductor. The magnitude of this signal will vary with excitation frequency, since excitation frequency determines the magnitude of the standing wave at the point of the defect. Thus, a plot of the magnitude of the signal appearing on the internal conductor versus frequency can be compared with the predicted location of the peak and minimums of the standing waves on the conduit transmission line to determine the location of defects in the conduit.

Two laboratory tests of this concept were conducted: one with a slot cut halfway through a coupling (placing the defect 10 ft from the signal source) and a second with a slot cut halfway through the conduit 4 ft from the signal source. The following equipment was used: an HP 8601' signal generator, an ENI Model 310L RF power amplifier, a Stoddard 91550 current probe, a Tektronix 454 oscilloscope, and an EMC 25 MKIII field intensity meter serving as voltmeter. The current probe was placed on a conduit at the end, where it was connected to the shielded room (the shorted end of the conduit transmission line). Its output was monitored on the oscilloscope and was kept constant by varying the output amplitude of the signal generator as the frequency was varied. It was necessary to do this since the impedances of the signal source and the transmission line cannot in general be matched. Since this end was shorted, a current maximum would always occur there. The results of these tests are plotted on Figures 8 and 9. The location of the defects can be determined by comparing these plots with the location of the standing waves shown in Figure 7 or more readily by calculation as described below. The plot in Figure 9 shows the defect at 4 ft from the signal source and a second smaller leak 10 ft from the signal source. This is the EMT coupling, which is known to be somewhat leaky. Thus, this technique appears able to resolve multiple defects.

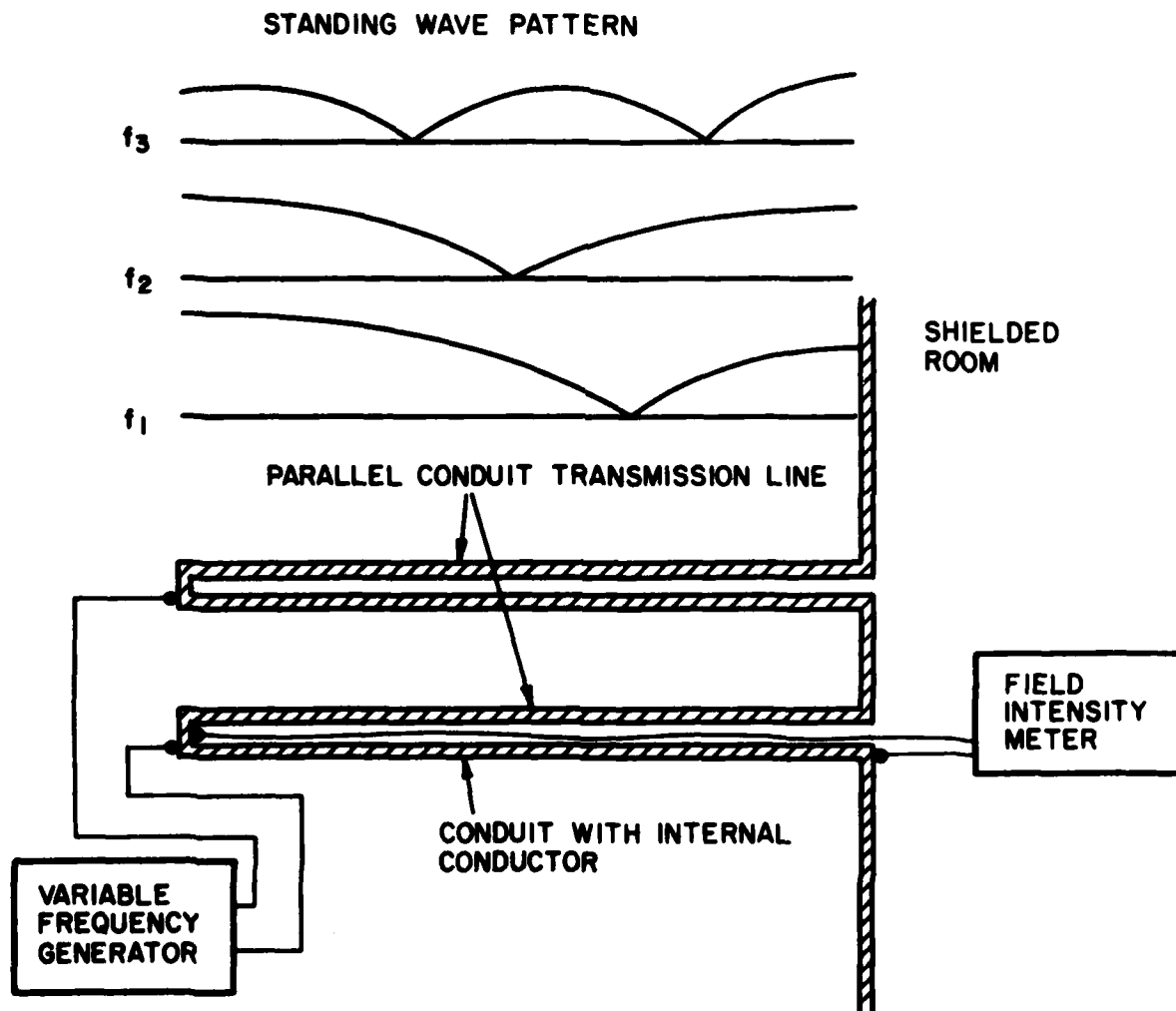

Figure 7. Standing wave pattern and test configuration.

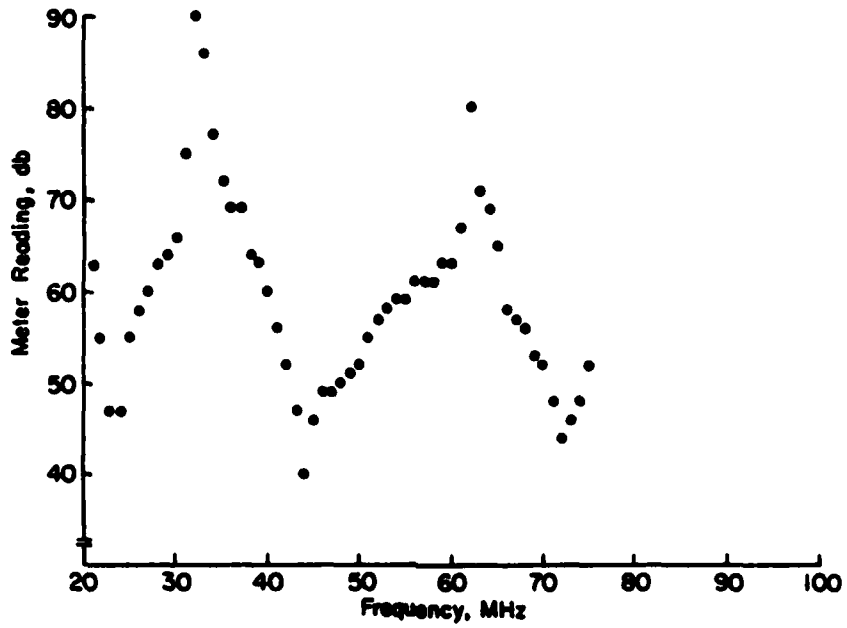

Figure 8. Magnitude of coupled signal versus frequency for a defect 10 ft from the signal source.

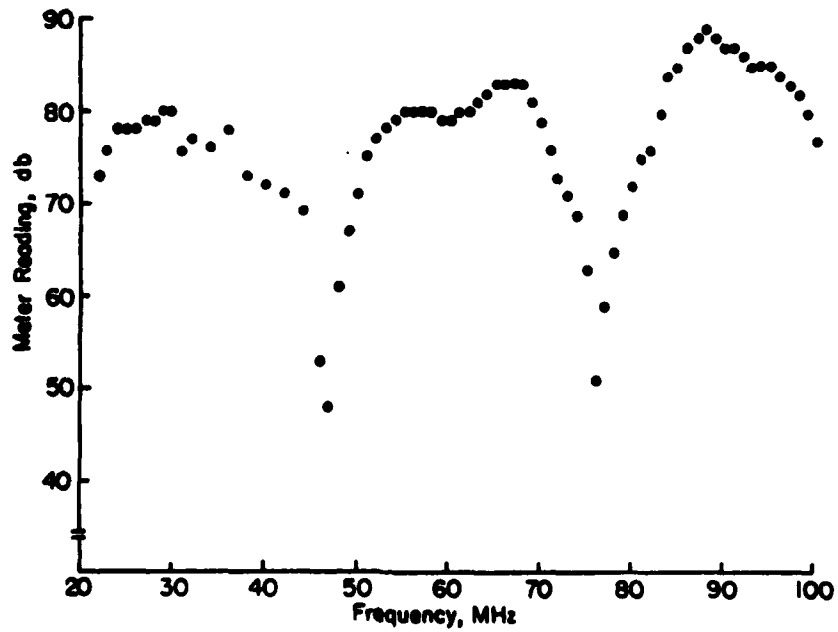

Figure 9. Magnitude of coupled signal versus frequency for a defect 4 ft from the signal source.

Calculation of Defect Locations

Defect location can be calculated in the following way:

1. Apply a CW signal to the conduit transmission line. The lowest useful frequency will be where the length of the transmission line is 1/4 wavelength. The wavelength on a transmission line is essentially the same as a wave propagating in the media in which the transmission line is located. Thus for conduit in air where L = length of conduit under test and f_1 (MHz) = the lowest useful frequency:

$$f_1 = \frac{300}{4L} \text{ MHz}$$

2. Monitor and record voltage readings versus frequency on a conductor internal to the conduit being tested. (Keep peak standing wave values on the conduit transmission line constant as frequency is changed.)

3. Significant voltage variations as the applied frequency is varied indicate defects.

4. Note the frequency at which voltage minimums occur on the internal conductor as the applied frequency is varied. (These minimums result when the nodes of the standing wave coincide with the location of a defect.)

5. Take the frequency (f_2) at lowest frequency minimum noted to determine d , the distance of the defect from the shorted end of the conduit transmission line.

$$d_2 = \frac{300}{4f_2}$$

where f_2 is in MHz.

Ambiguities may exist at multiples of f_2 in that the minimums seen there can result from a defect associated at d_2 or at locations d_3 , d_4 , etc. where

$$d_3 = \frac{300}{4(2f_2)}, d_4 = \frac{300}{4(3f_2)} \dots$$

Existence of minimums at frequencies other than integral multiples of f_2 indicate additional flaws, the location of which are determined as in step 5; that is:

$$d_x = \frac{300}{4f_x}$$

Transmission Lines in Lossy Media

The practicality of applying the standing wave concept to buried conduits should be examined. Typical conductivities for earth materials are given in Table 5. Typical conductivities for metals range from approximately 1×10^6 to 6×10^7 mho/m, and conductivities of good insulators are typically less than 10^{-14} mho/m. Thus, earth materials are somewhere between good conductors and nonconductors, with soils tending toward the conductor spectrum.

Table 5

Conductivities (σ) of Earth Materials at Normal Temperatures and Pressures*

<u>Material</u>	<u>Approximate (σ) (mho/m)</u>
Soils ($\epsilon = 10$)	
Good	10^{-2} to 10^{-1}
Average	10^{-3} to 10^{-2}
Poor	10^{-4} to 10^{-3}
Water ($\epsilon_r = 81$)	
Sea ^r	4 to 5
Fresh	10^{-4} to 10^{-3}
Snow (drifted, wet)**	10^{-6} to 10^{-4}
Ice (glacial)	10^{-6} to 10^{-4}
Permafrost	10^{-5} to 10^{-4}
Marine sands and shales	10^{-1} to 1
Marine sandstones	10^{-2} to 1
Clay	10^{-2} to 10^{-1}
Sandstone (wet)	10^{-4} to 10^{-2}
Granite***	10^{-9} to 10^{-3}

*Kraichman, M. B., Handbook of Electromagnetic Propagation in Conducting Media, NAVMATP-2302 (U.S. Government Printing Office, 1970).

**Very dependent on temperature, frequency, and impurities.

***Very dependent on water content.

The skin depth in a media is a measure of the attenuation of a signal propagating into a conductor and can be useful as a tool to examine propagation characteristics of a transmission line in a conducting media. The general expression for skin depth δ is:⁵

$$\delta = \frac{1}{\alpha} = \frac{1}{\omega \sqrt{\frac{\mu\epsilon}{2} \left(\sqrt{1 + \frac{\sigma^2}{\omega^2\epsilon^2}} - 1 \right)}}$$

where ω is the radian frequency ($2\pi f$), μ is the magnetic permeability, ϵ is the dielectric constant, σ is the electrical conductivity, and α is the propagation constant (attenuation factor). The phase velocity (β) is:

$$\beta = \omega \sqrt{\frac{\mu\epsilon}{2} \left(\sqrt{1 + \frac{\sigma^2}{\omega^2\epsilon^2}} + 1 \right)}$$

⁵E. C. Jordan and K. G. Balmain, Electromagnetic Waves and Radiating Systems, Second Ed. (Prentice Hall, 1968), pp 126 and 130.

and the wavelength λ is:

$$\lambda = 2\pi/\beta$$

For free space, the wavelength is:

$$\lambda = c/f$$

where c = the speed of light = 3×10^8 m/s and f is the frequency in Hz.

Figure 10 is a plot of the theoretically determined wavelength of electromagnetic waves in media with conductivities in the range of earth materials as listed in Table 5. This plot shows that, up to relatively low conductivities, the wavelength is very dependent on conductivity. This adds a variable, since the wavelength in the media determines where the peaks and nulls of standing waves on transmission lines in that media will exist. Of more concern is the wave's attenuation, since, for a standing wave to exist on a transmission line, the magnitude of a reflected wave must be great enough to adequately reinforce or cancel the incident wave. A practical limit probably occurs when the wavelength is on the order of one skin depth. Table 6 lists the skin depth at several different conductivities and also the wavelength in the media (Figure 10). From the listed values, it appears that for typical soil conductivities (10^{-1} to 10^{-3} mho/m), the skin depth is considerably less than a wavelength. Usable standing waves would not exist on transmission lines buried in materials of these conductivities.

No specific tests were conducted to determine the standing wave concept's maximum sensitivity. However, use of continuous wave signals with narrow band tuned equipment should extend the dynamic measurement range beyond that possible from pulse measurement techniques.

Microwave Resonant Cavity

Microwave energy readily penetrates defects in electromagnetic shields. Thus, microwave illumination of electrical conduits used as shields may be useful for evaluating the conduits' EMP hardness. The standard microwave shielding test, which consists of using radiated power from a horn antenna, has the disadvantages of high ambient fields necessary for an adequate dynamic measurement range and of relatively inefficient power use. A resonant cavity, however, can have large fields contained within a relatively small, controlled volume (Figure 11). The fixture can be designed to open and "clip" onto a conduit at the location of a suspected defect. Leakage can be detected either by using an antenna probe placed within the conduit or by monitoring the signal induced on the coaxial system formed by a conductor inside the conduit. An alternate resonant cavity concept (Figure 12) uses a resonant cavity that instead of clipping onto the conduit, is placed next to the conduit, eliminating the need for different sized cavities for various conduit sizes and reducing the accessibility problem that exists with a large clip-around cavity.

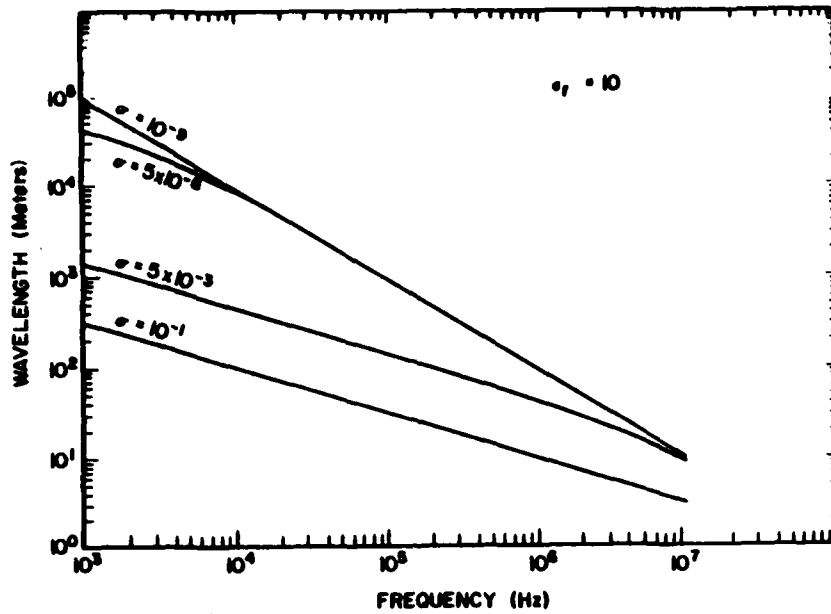

Figure 10. Wavelength of electromagnetic waves in lossy media.

Table 6

Skin Depth (δ) in Earth Materials of Various Conductivities (in meters)

$\epsilon_r = 10$

σ (mho/m)	Frequency			
	10 kHz	100 mHz	1 mHz	10 mHz
10^{-1}	16	5.2	1.6	.53
5×10^{-2}	71	23	7.7	3.6
5×10^{-6}	3.6×10^3	3.4×10^3		
10^{-9}	1.7×10^7			

Wavelength (in m)

σ (mho/m)	Frequency			
	10 kHz	100 kHz	1 mHz	10 mHz
10^{-1}	100	32	10	3.1
5×10^3	447	140	42.3	8.7
5×10^{-6}	8.7×10^3	9.5×10^2	95	9.5
10^{-9}	9.5×10^3	9.5×10^3	95	9.5
Free space	3×10^4	3×10^3	3×10^2	30

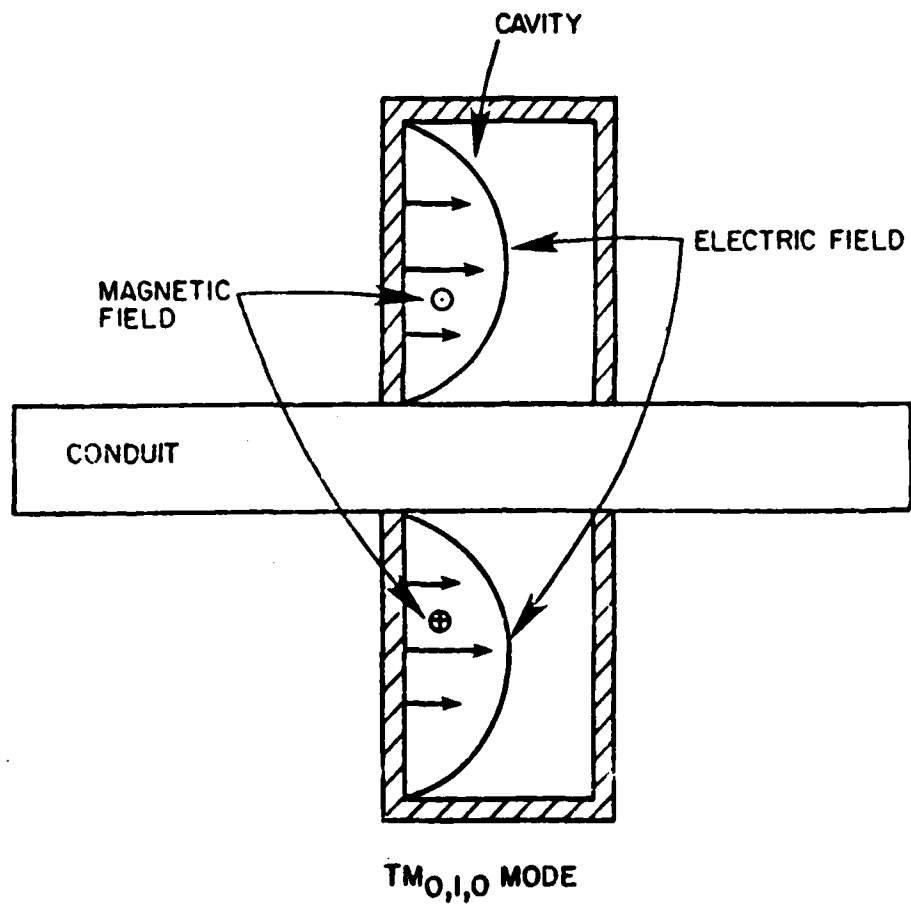
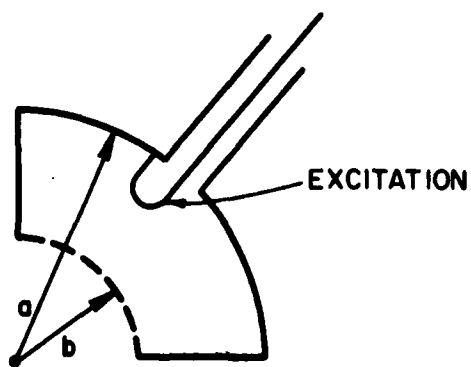

Figure 11. Microwave resonant cavity test fixture.



**QUARTER ROUND MICROWAVE
RESONANT CAVITY**

Figure 12. Alternate resonant cavity design.

An experimental study was conducted at CERL using an S-band resonant cavity designed for use on a 1/2-in. EMT thin-walled conduit. This size conduit was chosen to provide a convenient cavity size and the S-band frequency range (rather than a higher frequency) was used to ensure mode separation in the cavity. EMT has an advantage for EMP testing in that couplings and other hardware are pressure fittings and are somewhat EMP "leaky" in their normal installation, thus it is not necessary to produce an artificial defect.

The cavity was excited by applying an input signal to a small loop installed near the outer edge of the cavity. A detecting loop was located 180 degrees opposite the feed loop. The detecting loop was used to determine resonance. Equipment used for the test included a Hewlett Packard 616A signal generator as a signal source (maximum output of 1 mW), a Tektronix 491 spectrum analyzer for determining resonance, and a Stoddard NM-65T microwave receiver for measuring the leakage signal. Two 10-ft sections of conduit were joined with an EMT coupling for the test. The conduit was provided with an endcap at one end and an internal conductor consisting of a 12-gage insulated copper wire terminated in 56 ohms at each end (the approximate characteristic impedance of a 12-gage wire in a 1/2 in. EMT). The second end of the conduit system was attached to a shielded room that contained the microwave receiver. The results of the tests are as follows (readings were taken as a voltage across the terminating resistor inside the shielded room):

<u>Condition</u>	<u>Reading on Receiver</u>
1. Solid conduit	5 to 8 μV^*
2. Transverse slot halfway through conduit	20 to 30 μV
3. Transverse slot halfway through coupling	84 to 120 μV
4. Longitudinal slot 1-in. long	20 μV
5. Good coupling	10 to 25 μV

*The receiver noise level was approximately 5 to 8 μV . The data show the maximum range of values obtained for each condition: readings were somewhat sensitive to the position of the test leads.

The maximum power available from the signal generator for this test was 1 mW. The cavity could absorb significantly higher power (probably 10 W or more), increasing the measurement range by about 40 dB with the proper driver.

Diffusion Current-Leakage Phase Comparison

A CW signal of sufficiently low frequency applied onto a conduit will propagate or diffuse through the wall of that conduit. Such propagation is subject to a frequency-dependent exponential attenuation. The magnitude of this reduction can be calculated by using skin effect phenomenon equations. A signal that passes all the way through the conduit wall can be detected by a

conductor inside the conduit. The phase relationship between the applied signal and the internal signal is fixed by the applied frequency, the conduit's wall thickness, and the conduit material's electromagnetic properties. A leakage signal (leakage depends on flux linkage), appearing on a conductor inside the conduit will be in phase with the applied signal. The signal passing through the conduit wall will be different in phase from the applied signal except when the propagation distance through the conduit wall is an integral number of wavelengths. The frequency of the applied signal can be chosen so the wavelength in the metal is not an integral wavelength. Then an in phase signal appearing inside the conduit indicates leakage.

With reference to Figure 13, imagine a metal one wavelength thick (Figure 13a). The phase lag of the wave appearing on the bottom of the slab or inside a conduit) in relation to the wave at the upper surface is -360 degrees. In Figure 13b, the phase lag is ϕ degrees through a thickness (t) of metal. Thus,

$$\frac{\phi}{360} = \frac{t}{\lambda}$$

$$\text{or } \phi = \frac{360t}{\lambda} = \frac{360t (\pi\mu\sigma f)^{1/2}}{2\pi} \text{ in degrees}$$

where $\lambda = 2\pi\delta$ is the wavelength in the metal; δ is the skin depth, μ is the magnetic permeability, σ is the electrical conductivity of the conduit metal, and f is the frequency in Hz.

An experiment was conducted to determine the usable frequency range for phase comparison between an externally applied signal and a diffusion current signal inside a 1-in. rigid-walled steel conduit and a 1-in. rigid-walled aluminum conduit. The test configuration was as shown in Figure 13 in which a conduit is attached to a shielded room. The opposite end was terminated with a steel endcap for the steel conduit and a brass endcap for the aluminum conduit. A wire internal to the conduit was attached inside the endcap. The other end of this wire was attached to the inside wall of the shielded room. The conduit was externally excited by a signal generator. The phases of the excitation signal and the diffusion signal were compared using the phase read-out of a Hewlett Packard Model 3575A gainphase meter using inductively coupled current probes as sensors. Test results are listed in Tables 7 and 8.

From these data, it appears that one wavelength is about 800 Hz in conduit steel and above 20,000 Hz for aluminum. The diffusion current magnitude is considerably reduced at one wavelength in the metal and is quickly reduced to a value too low to measure. Thus if a phase comparison is desired, the applied test frequency should be such that the distance through the metal (t) is less than one wavelength.

Little information is available on the magnetic and electric properties of conduit metals, but it is not likely these properties are very uniform. The maximum usable frequency for different sized conduits can be estimated using the permeability-conductivity factor ($\mu\sigma$), which is found by solving the previous equation for $\mu\sigma$:

$$\mu\sigma = \frac{4\pi \phi^2}{360 ft^2}$$

where ϕ is the measured phase delay between the applied signal and the diffusion signal, f is the applied frequency, and t is the conduit wall thickness. Calculated values for $\mu\sigma$ are listed in Tables 7 and 8 along with the experimentally determined values of phase delay. The experimental accuracy can be estimated from data for the aluminum conduit. Since the relative permeability of aluminum is 1 and the handbook value for σ (the conductivity) is 3.82×10^7 mho/m the theoretical value for $\mu\sigma$ is 48. In this experiment, $\mu\sigma$ varied from approximately 26 to 42. However, the actual conductivity of the aluminum conduit was not measured and may be somewhat less than the handbook value. The relative permeability for the conduit steel using $\sigma = 6 \times 10^6$ mho/m is approximately 150, which is in the range of other estimates.

Table 9 lists estimated frequencies at which the wall thickness of rigid-walled steel conduit is approximately one wavelength. These values were obtained by solving the equation:

$$\phi = \frac{360t (\mu\sigma f)^{1/2}}{2\pi}$$

for f or:

$$f = \frac{4\pi\phi^2}{360^2 t^2 \mu\sigma}$$

At one wavelength, $\phi = 360$ degrees and the equation becomes:

$$f = \frac{4\pi}{\mu\sigma t^2}$$

The list in Table 9 was calculated using two values of $\mu\sigma$: 1200, which is an average from a number of experimental measurements, and 1370, which was the experimentally determined value for the 1-in. conduit at 800 Hz.

Analysis of Results

In general, all four new tests depend on some type of electrical excitation of the conduit and therefore are not suited for use with buried conduits. The following analysis suggests that although promising for special applications, the methods should be further developed and field tested before they can be recommended for general EMP hardness verification and defect location.

Hall Effect

This technique as studied at CERL requires continuous direct access to the section of conduit being tested, and each different size conduit requires a unique test fixture. The test fixture problem may be mitigated to some extent by a more versatile fixture design. The test is subject to geometry-dependent variables: couplings, unions, and other hardware that involve a dimensional change cause problems in test fixture design and data analysis. If the test fixture problem could be resolved, however, normal "signatures" for conduit hardware could be stored in instrumentation for comparison. Another consideration is that, quite often, there is no convenient current injection point unless the conduit system is specifically designed to be tested by this concept.

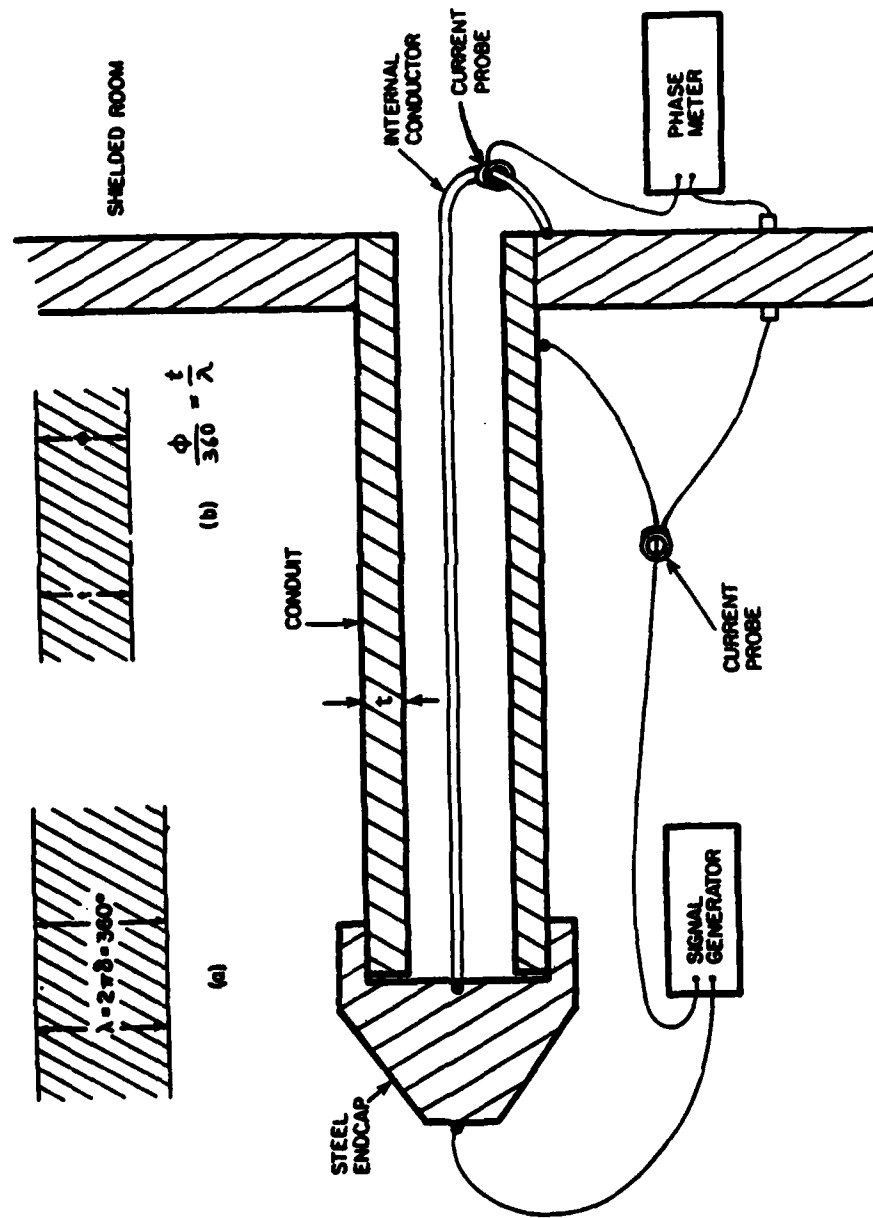

Figure 13. Phase delay of a signal propagating through a metal slab, and test configuration used.

Table 7

Diffusion Current Phase Lag For 1-in.
Rigid-Walled Steel Conduit (Wall Thickness = $.338 \times 10^{-2}$ m)

<u>Frequeny (Hz)</u>	<u>Phase Lag (Degrees)</u>	<u>Permeability-Conductivity Factor ($\mu\sigma$)</u>
60	-89.0	11.20
70	-97.3	11.48
80	-104.6	11.61
90	-111.9	11.81
100	-118.5	11.92
120	-129.9	11.93
150	-146.3	12.11
200	-169.7	12.22
300	-208.9	12.35
400	-240.1	12.23
500	-274.4	12.78
600	-306.9	13.32
700	-336.0	13.69
800	-359.6	13.72
900	-378.8	13.53
1000	-390.1	12.92
1500	-438	10.85
2000	Signal lost	
3000	in noise	

Table 8

Diffusion Current Phase Lag For 1-in.
Rigid-Walled Aluminum Conduit

<u>Frequeny (Hz)</u>	<u>Phase Lag (Degrees)</u>	<u>Permeability-Conductivity Factor ($\mu\sigma$)</u>
400	-40.7	35
500	-42.1	30
700	-46.9	26.7
1000	-55.9	26.5
2000	-83.1	29.3
4000	-128.0	34.7
8000	-189.0	37.9
10000	-208	36.7
20000	-312	41.3

Table 9

Estimated Frequencies at Which Rigid-Walled
Steel Conduit Is One Wavelength Thick

<u>Nominal Size of Conduit (in.)</u>	<u>Wall Thickness in (m x 10⁻²; nominal)</u>	<u>Frequency at Which Wall Thickness is One Wavelength (Hz)</u>	
		$\mu\sigma = 1200$	$\mu\sigma = 1370$
1/4	.224	2000	1830
3/8	.234	1900	1680
1/2	.277	1350	1200
3/4	.287	1270	1110
1	.338	920	800
1-1/4	.356	830	720
1-1/2	.368	770	680
2	.391	680	600
2-1/2	.518	390	340
3	.549	350	300
3-1/2	.574	320	280
4	.602	290	250
5	.655	240	210
6	.711	210	180

Standing Wave Coupling

This defect location concept is probably the most versatile of those examined, although some difficulties in implementation are apparent. One important drawback is the problem of maintaining a transmission line configuration for the conduit system. However, in most cases, this method can be used for both hardness verification and defect location and should be especially useful for locating leaks in long conduit runs.

Microwave Resonant Cavity

Like Hall effect testing, this method requires direct access to the conduit being tested. A microwave resonant cavity test would probably be most useful in conjunction with visual inspection. For example, conduit hardware that appears to be suspect could be subjected to the microwave test to determine its electromagnetic properties. Thus, the test's greatest potential is in testing a specific, identified conduit feature for leaks.

Diffusion Current-Leakage Current Phase Comparison

This low-frequency phase comparison can be used for hardness verification, but defect location is not possible. Thus, the method will determine if a leak exists along a conduit system, but actual leak location must be attempted using some other technique.

Field Use of New Methods

Although not addressed in this study, actual conduit configurations at existing structures are likely to present problems in using these methods. For example, use of over-the-conduit test fixtures may be impeded by conduit design or conduit supports; or, conducting materials may make a transmission line excitation impossible. If it is known that a particular test will be used, it should be possible to design the conduit system to facilitate use of that test.

4 CONCLUSIONS AND RECOMMENDATIONS

Four concepts have been investigated for usefulness in determining the EMP shielding integrity of electrical conduits. These methods also were compared with existing tests. The new methods may have some use in testing a conduit's shielding integrity; however, because of constraints associated with their physical implementation, none appear to have universal use. Thus, when considering these methods for use, the limitations of each should be noted carefully.

Conduit systems for new structures can be designed for EMP hardness testing by a specific method. For most current uses, however, the test concepts studied here must receive further development and field testing before they can be recommended.

REFERENCES

- Agee, F. V., and H. A. Roberts, The Development of a Pulsed Loop Antenna Conduit Electromagnetic Radiator (PLACER) - HDL-TR 1850 (Department of the Army [DA], September 1978).
- Goodwin, D. L., The PLACER: Assembly and Operation, HDL-TM-77-7 (DA, April 1977).
- Jordan, B., Electromagnetic Waves and Radiating Systems, Second Ed. (Prentice Hall, 1968).
- Kraichman, M. B., Handbook of Electromagnetic Propagation in Conducting Media, NAVMATP-2302 (U.S. Government Printing Office, 1970).
- Nielsen, P., EMP/EMI Hardening of Electrical Conduit Systems, TR M-292/ADA107133 (U.S. Army Construction Engineering Research Laboratory, September 1981).
- Nuclear Electromagnetic/Pulse (NEMP) Protection, TM 5-855-5 (DA, February 1974).
- Roberts, H., et al., EMP Testing of Buried Conduits, The Pulsed Dipole and Pulsed Transmission Line, ADA0172991 (DA, September 1976).

DISTRIBUTION

DTIC (12)

DMA (6)

ATTN: EMP Effects Div.

Nielsen, Paul H.

Laboratory evaluation of electromagnetic pulse (EMP) hardness testing concepts for electrical conduit systems. — Champaign, Ill. : Construction Engineering Research Laboratory ; available from NTIS, 1984.

32 p. (Technical report / Construction Engineering Research Laboratory ; N-350)

1. Electric conduits. 2. Shielding (electricity). 3. Electromagnetic pulse. I. Title. II. Series: Technical report (Construction Engineering Research Laboratory); N-350.

END

FILMED

10-84

DTIC