

AD-A145 496

DESIGN CONSTRUCTION DEMONSTRATION AND DELIVERY OF AN
AUTOMATED NARROW GAP WELDING SYSTEM(U) CRC AUTOMATIC
WELDING CO HOUSTON TX 31 MAR 83 CRC-NAV-A/W-7
N00600-81-C-E923

1/1

UNCLASSIFIED

F/G 13/10

NL



END
DATE
FILMED
10 84
DTIC

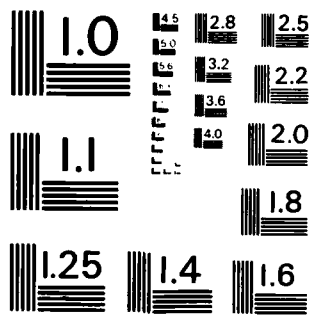

MICROCOPY RESOLUTION TEST CHART
NATIONAL BUREAU OF STANDARDS - 1963 - A

Phase 3 Report
3/31/83
-- Page 2 --

Phase 2 was also completed slightly ahead of schedule and the Phase 2 report, CRC No. NAV A/W 4, was submitted June 29, 1982. This report covered the detailed design of the Narrow Gap welder.

PHASE 3 EQUIPMENT CONSTRUCTION

This Phase 3 report summarizes the work done from June 30, 1982 through March 31, 1983.

The objective of Phase 3 was to fabricate and test the prototype Narrow Gap welding system. The welding system was fabricated per the initial preliminary drawings as indicated in the Phase 2 portion of this contract. The unit was assembled and mechanical evaluation was performed. Figures 1, 2 and 3 show the completed prototype.

Discussion of Problems and Solutions Determined During Construction

Head Angle Rotation Mechanism - During the initial testing of the mechanical systems, it was determined that a problem existed with the head angle rotation mechanism. The original design criteria had assumed an approximate torch assembly weight of 17 pounds. After final design and construction, the torch assembly weight increased to about 23 pounds. This additional weight caused a severe problem on the head-angle, rotation-drive system. To solve this problem, it was necessary to redesign the head angle mechanism. This redesign involved an additional gear reduction to be included in the mechanism. The gear reduction was increased from a ratio of 72 to 1 to a final ratio of 360 to 1. This increase in the gear reduction allowed

Phase 3 Report
3/31/83
-- Page 3 --



Added on file

A-1

the head-angle motor to provide sufficient torque for lifting the additional weight of the torch assembly.

Main Oscillator Shaft Mechanism - The additional weight of the torch assembly also created a problem with the idler-roller-suspension system used on the main oscillator shaft. The original design had a single idler shaft riding on a single flat on the main oscillator assembly. To sustain the extreme loads exerted on the oscillator shaft from the increase in the weight of the torch assembly, it was necessary to provide an additional cam follower assembly on the opposite side of the oscillator shaft.

It was also necessary to increase the radial diameter of the roller bearing assembly to distribute more evenly the high rotational loads exerted on the oscillator shaft. It was also necessary to harden the main oscillator shaft to prevent excess wear of the flat surfaces during operation of the oscillator assembly.

Extensive testing was performed on the main oscillator shaft and head-angle rotation system prior to initial welding trials. During this test period, approximately 280,000 cycles of the oscillator assembly were performed and the main assembly was disassembled and inspected for wear of the various components. During this evaluation it was determined that no appreciable wear had occurred. Subsequent testing at maximum oscillator velocities and oscillator widths was then performed. The results of this test indicated that no appreciable wear was occurring.

To substantiate further results of the "wear tests", the unit was completely reassembled and then operated continuously for a period of approximately 168 hours. During this operational test, the unit was exercised using a computer control which allowed various oscillating widths and oscillating velocities to be loaded during the test sequence. On completion of this test cycle, the unit again was dismantled and all main running components evaluated for wear. The conclusion of the test indicated no appreciable wear to the main oscillator and head angle components.

Upon further performance evaluation of the oscillating system, it was determined that the existing oscillator drive system was marginal. The torque required to accelerate and decelerate the oscillating system during the welding sequence was greater than initially anticipated. It was determined that an increase in motor torque was required to solve this problem, so a larger stepper motor was installed. To locate the larger stepper motor into the oscillator housing, it was necessary to reverse the location of the oscillator drive motor. This required fabrication of new mounting brackets as well as a new oscillator yoke assembly. The new drive motor provided an increase of approximately 1 1/2 times the initial torque. Performance evaluation of the new oscillator motor has indicated a 60 percent reserve torque available to assure proper oscillator motion.

Tractor Drive Assembly - On completion of the mechanical performance test the welding system was assembled and weld performance trials were

Phase 3 Report

3/31/83

-- Page 5 --

performed. During this welding evaluation a problem with the tractor drive assembly was determined. The problem was that the four-idler-wheel suspension used to support the weight of the welding unit on the welding track could become unstable due to variations in the track fabrication and possible distortion of the track. To overcome this problem, the idler wheel assembly was redesigned. The redesign used only three idler wheels instead of the original four. This placed the welding carriage on a tripod mount. The tripod idler wheel assembly allowed the welding unit to remain stable during deviations in the welding track.

Gas Shield Assembly - the design of the gas shield assembly was based on the work summarized in the Second Progress Report, NAV A/W 3, dated June 1, 1982. Initial welding trials with the completed assembly showed inadequate gas shielding in the deeper, narrow-groove joints. With the original design it was necessary to increase gas flows to approximately 350 to 400 cubic feet an hour to sustain proper gas coverage. This intense gas flow rate caused compressive disturbances on the plasma column which induced severe tracking problems. It also caused very fine, sub-surface porosity.

Subsequent testing of the gas shield assembly indicated that the excessively-high flow rates were causing the gas to be distributed into the welding joint with extremely high velocities. The high velocity of the gas flow as it was emitted from the gas shield assembly was causing

Phase 3 Report
3/31/83
-- Page 6 --

turbulence resulting in aspiration of air into the gas shield as well as into the welding joint.

An analytical analysis was made on the gas assembly at various flow rates and it was determined that the gas shield assembly must be reduced in volumetric size. By reducing volumetric size, it was then possible to reduce the flow rates. A subsequent modification of the gas shield assembly reduced its volume by 1/3. This allowed a reduction in the volumetric flow rates to approximately 130 cubic feet per hour. Further welding evaluation indicated that instability still existed in the welding arc plasma column as well as a continual aspiration of air into the welding joint.

Studies of the gas shield assembly revealed that the configuration of the gas tube itself and its placement within the gas shield assembly was extremely important. A gas shield assembly was fabricated that would allow easy removal and replacement of the gas tube. Numerous configurations were evaluated by the use of an external smoke producing source. By the use of the external smoke source, it was possible then to visually monitor the actual flow from the gas shield assembly. As a result of this test, it was determined that the gas tube itself must be located at the outer extremes of the gas shield assembly. It also indicated that the gas tube itself, must have a slotted opening that allows gas to emerge from the remaining exposed surfaces.

It was also determined that the best gas tube configuration was a parallel

tube arrangement with a single tube located on either side of the gas shield assembly and joined together to a single gas inlet at the rear of the enclosure. To evenly distribute the gas flow leaving this gas tube assembly, it was necessary to increment the spacing interval between the gas tube slots, the largest spacing occurring at the termination end of the gas tube. The reason for this uneven spacing was to regulate the velocity of the gas flow down the gas tube. The gas at the inlet side of the gas tube had a very high velocity, decreasing to zero at the end of the tube. The high velocity at the inlet side provides for a minimal flow from the gas slots. By placing a larger number of gas slots at the beginning of the tube and a minimal number at the end of the tube, it was possible to achieve a fairly uniform balance of gas flow. To insure proper distribution of the shielding gas from the gas assembly it is important to have a uniform flow from the gas tube assemblies.

To provide a laminar flow from the gas shield assembly, it was necessary to loosely pack coarse steel wool around the gas tube assemblies. The stainless steel wool breaks up the velocity flow from the gas tube assemblies and provides a proper laminar flow from the shield assembly. The steel wool is then retained by a meshed screen.

During further investigation into the gas shielding problems, it was also identified that the welding torch may block the gas flow in the narrow

Phase 3 Report

3/31/83

-- Page 8 --

groove joint. To alleviate this problem, a secondary shield was added to the welding torch. At the base of the welding torch, vertical slots were located on either side of the welding tip. Parallel gas tubes then were used to distribute shielding gas on each side of the welding tip. The top portion of the torch assembly was manifolded to provide proper distribution of the gas flow and also provide the water cooling passages required by the torch. At the upper most end of the torch assembly, an additional gas distribution and water distribution block was fabricated. This block provided the separation of water flow to insure a series connection between the welding torch water jacket and the gas shield water jacket. The additional function of this block was to provide a flow division between the gas shield assembly and the gas lenses on the welding torch. The block was fabricated with a controlled orifice size allowing approximately an 8 to 1 division in the gas flow to the gas assemblies with the smaller flow at the contact tip down in the weld joint. This then provided a very gentle flow at the base of the torch surrounding the immediate welding arc. By using this dual shield configuration, it was then possible to provide adequate shielding at the 4-inch joint depth with the narrow groove configuration.

Figure 4 shows the final gas shield configurations as evaluated on the Narrow Gap welding system. By using the combinational gas shielding assembly, it is now possible to reduce the gas flow rates to a value ranging from 80 cubic feet an hour to 100 cubic feet an hour representing

Phase 3 Report

3/31/83

-- Page 9 --

a significant reduction in the amount of gas consumption needed for proper shielding.

Another important factor with regards to the gas shielding configuration was an adequate means of sealing the top of the gas shield assembly. The opening required in the top of the gas shield for the welding torch to be telescoped through the assembly must be properly sealed. The sealing system used in the Narrow Gap welding system is a silicon-rubber gasket with a single slot opening for the torch. This allows the torch to telescope through the gas shield assembly while still providing adequate protection from the aspiration of air.

Another important area of consideration was the transfer of shielding gas from the gas shield assembly to the work piece. To assure proper distribution of the gas over the welding joint, a flexible skirt was fabricated and used to interface the gas shield to the work piece. This skirt was fabricated from Refrasil* which can withstand extremely high temperatures.

Wire Straightening Mechanism

During the welding trials it was determined that an additional wire straightening mechanism would have to be added. The wire feed assembly

* Trademark for glass woven cloth

Phase 3 Report
3/31/83
-- Page 10 --

has a single directional wire straightener attached to the wire feed housing. However, this single straightener did not completely straighten the wire from the welding torch. A secondary wire straightener was added which can be rotated 360° around the incoming wire. This additional wire straightener then provides an additional angle of correction for straightening the welding wire.

Software Modifications

All of the aforementioned modifications have been made to the original design concept and have been evaluated during the initial welding trials. Also, some modifications were made to the original software operating routines. The primary change was the method of extracting the necessary tracking referencing information for proper sidewall fusion. In the standard configuration of the control algorithm, a sample of the weld pool profile is taken at centerline and is used for the sidewall tracking references. However, in the narrow gap configuration, it was necessary to move this sampling area closer to the actual sidewall. The change in the basic algorithm now allows a weld pool sample to be taken just prior to the start of integration for sidewall tracking. This change allows the control to be less sensitive to centerline weld pool flood.

During the welding evaluation phase, numerous chart recordings were taken of the processed voltage and current signals and an analysis performed in order to interpret the actual weld pool profile. It was noted that the center of the weld pool remained slightly higher than the weld

Phase 3 Report
3/31/83
-- Page 11 --

pool at the sidewalls. This condition caused an error in the normal tracking method. Taking the weld pool sample close to the sidewall overcomes this problem. This allows a better control of the wetting action of the weld pool into the sidewall.

Additional changes were made in the welding machine arc voltage control. Normally, the arc voltage controller is engaged only at centerline during the welding operation. However, in the Narrow Gap welding system, it was necessary to maintain the arc voltage controller throughout the weld cycle because of the centerline flood conditions. It was also necessary to input a hot-start configuration to the control. The hot-start allows the arc voltage to be increased to approximately 40 volts prior to arc starting. Once the arc is initiated, the controller then resumes its normal role of controlling the preset welding voltage. This hot-start configuration provides a better starting characteristic in the narrow groove. All of these modifications have been incorporated in the current running software and have improved the overall performance of the system.

Evaluation of Welding Power Supplies

The Columbus Laboratories of Battelle Memorial Institute was subcontracted to evaluate commercial welding power supplies for consideration as a part of

the Narrow Gap welder. Three welding power supplies were evaluated on this program. These were:

- (1) Hobart Mega-Mig 450RVS
- (2) Linde VI-450SS
- (3) Miller Deltaweld 450

These are solid-state constant-potential power supplies rated at 450 amps at 100 percent duty cycle. They are intended specifically for use with gas metal-arc welding although certain accessories may be added to convert to use with shielded metal-arc (covered electrode) welding. As a group, they are intended for industrial application, are similar in size and have approximately the same operating characteristics, controls, and features. They are made by the three major power supply manufacturers so service and parts should be readily available from local sales outlets.

The power supplies are silicon controlled rectifiers with a solid-state contactor and control circuitry. Power filtering capacitors are connected across the rectifier output leads to provide a smooth DC output. The Linde unit is provided with variable inductance that can be used to regulate the response rate of the power supply which is used to reduce spatter when welding in the short-circuiting-arc mode. For spray-transfer narrow-gap welding, this feature is not needed so the inductance setting was kept at zero during the experiments.

The control panel of each unit has an ammeter and voltmeter to monitor the arc voltage and welding current. Each unit has various controls in addition to the voltage control. For the most part, these would not be needed with the microprocessor-controlled narrow-gap-welding operation, so no attempt was made to evaluate their usefulness.

Experiments were conducted to examine various operating characteristics of the three power supplies. Welds were made during which the output current and voltage were recorded and the wave shapes of the current and voltage were measured. A series of nonwelding experiments were conducted in which the power supplies were hooked to a resistive load bank. In this series, current-voltage curves were developed, the reaction times to rapid load changes were measured, the effect of drops in line voltage were determined, and the power supplies were operated under load for long-time periods (about 1/2 hour).

Of the three power supplies, the Miller Deltaweld 450 had the best operating characteristics with the Linde VI-450 SS being almost as good. Either of these power supplies should perform satisfactorily in the narrow-gap welding system. The Hobart Mega-Mig 450 RVS lacked the uniformity of current and voltage output necessary for microprocessor control. While it operated perfectly satisfactorily when welding, the "millisecond" fluctuations of current and particularly voltage were far in excess of any fluctuations measured for the Linde or Miller power supplies.

It was for these reasons that the Hobart was judged not satisfactory for this application.

The Linde and Miller were very similar in operation. The Miller generally had slightly more uniform current and voltage output. From this standpoint, the Miller could be considered more suitable. Two anomalies were observed in Miller operation, but these should not affect its operation under microprocessor control. One was related to line voltage drop response. When the line voltage drops, the output of the Linde and Miller closely follow the drop and rise of the line voltage with the change in Miller output being less than the change in Linde output. However, the Miller outputs exhibited an extra, short-time (0.010 to 0.017 second) drop in both current and voltage at the start of the line voltage drop. In some of the experiments, a similar short-time pulse of current and voltage occurred when the line voltage returned to normal. The microprocessor should be capable of handling this extra drop and pulse of current and voltage particularly since they are discrete occurrences and not a continuous, cyclical variation.

The second anomaly occurred after the Miller had been operating continuously under load for about one-half hour. Voltage spikes occurred each sixth cycle in the output voltage wave. This was attributed to a malfunction of one of the six ^{*}SCR's that appeared only after long-time operation.

* silicon controlled rectifier

Phase 3 Report

3/31/83

-- Page 15 --

The one-half hour operation corresponded to the continuous welding of a 25-foot-long joint. If the spikes were caused by one of the SCR's, this behavior would be related to this one particular power supply and may not be observed in any other Miller power supply.

The half-hour operation at 350 amps using the load banks could be considered as operating in excess of the 10-minute 100 percent duty cycle rating of 450 amps. However, it was Battelle's recommendation that a larger power supply be used. As a result, a Deltaweld 650 (rated 650 amperes at 100 percent Duty Cycle) was purchased for the Narrow Gap welder and has been used for the welding trials at CRC as a part of the Phase 3 evaluation.

Welding During Phase 3

Twenty-two complete welds were made during Phase 3 to evaluate the completed system and generate welding data for construction of adaptive software. These welds were deposited in 2 3/8-inch-thick, HY 100 plate, using 1/16-inch-diameter Linde 95 filler wire and 95 argon-5 CO₂ shielding gas.

The range of welding parameters used are shown in Table 1. It should be noted that at this time no effort has been made to maximize production or restrict heat input. The objectives of this welding were to evaluate the mechanisms, verify the tracking capability of the system, and obtain sidewall fusion.

Joint Design

It was apparent from the early stages of our test welding that a modest bevel angle is required. This is necessary as the shuttle type oscillator causes the contact tip to touch the sidewall before the arc is sufficiently close to obtain good sidewall fusion. A bevel of 5 degree included angle appears adequate.

Satisfactory welds were deposited in joints with 3/8-inch root spacing and 5/8-inch spacing on the top of the 2 3/8-inch plates. An in-depth study of joint tolerance will be carried out in Phase 4.

Quality

During Phase 3, no non destructive testing of completed welds were made. However, several cross sections have been taken and no defects observed. Visual inspection during welding has indicated that undercutting the sidewalls is the major defect incurred during welding, but this can be controlled with parameter adjustment.

Charpy vee-notch specimens were removed from one of our early welds and tested. The results were :

<u>Test Temperatures, F.</u>	<u>Notch Toughness, Foot-pounds</u>
0°	159, 144, 134, 176, 140
-120°	22, 27, 31, 38, 37

In addition, a weld sample was sent to DTNSRDC for drop weight tear tests.

Phase 3 Report
3/31/83
-- Page 17 --

TABLE I
SUMMARY OF PARAMETERS

Wire Feed Speed, ipm.	235
Travel Speed, ipm	8.0 - 11.5
Voltage, volts	24.0 - 26.0
Amperage, amperes	310 - 360
Heat Input, Kilo-joules per inch	45 - 73
Contact-Tip-To-Work Distance, inch	.850
Head Angle, degrees (trailing)	-5
Oscillation Rate, inch/second	0.75
Dwell, Milliseconds	70

Phase 3 Report
3/31/83
-- Page 18 --

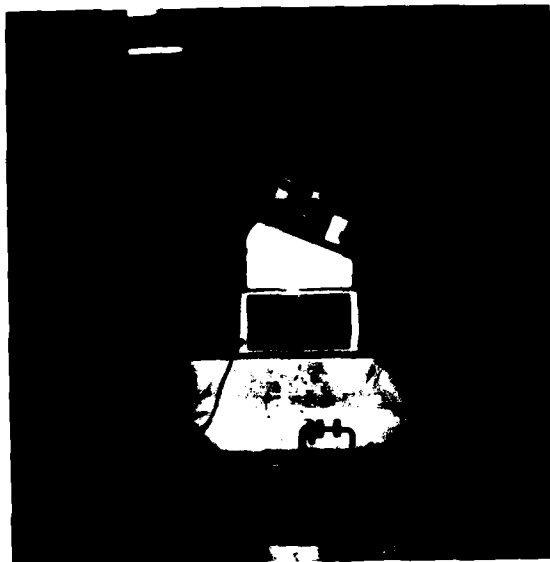

FIGURE 1

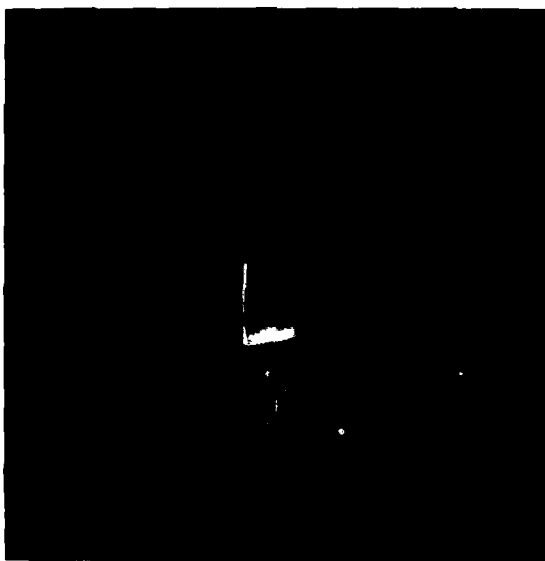

FIGURE 2

Phase 3 Report
3/31/83
-- Page 19 --

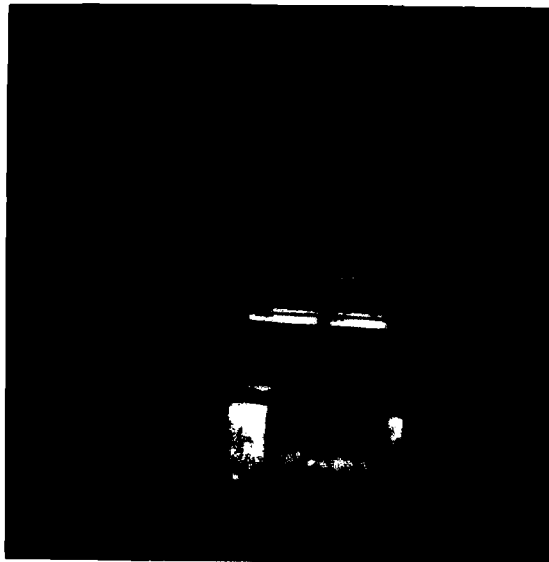
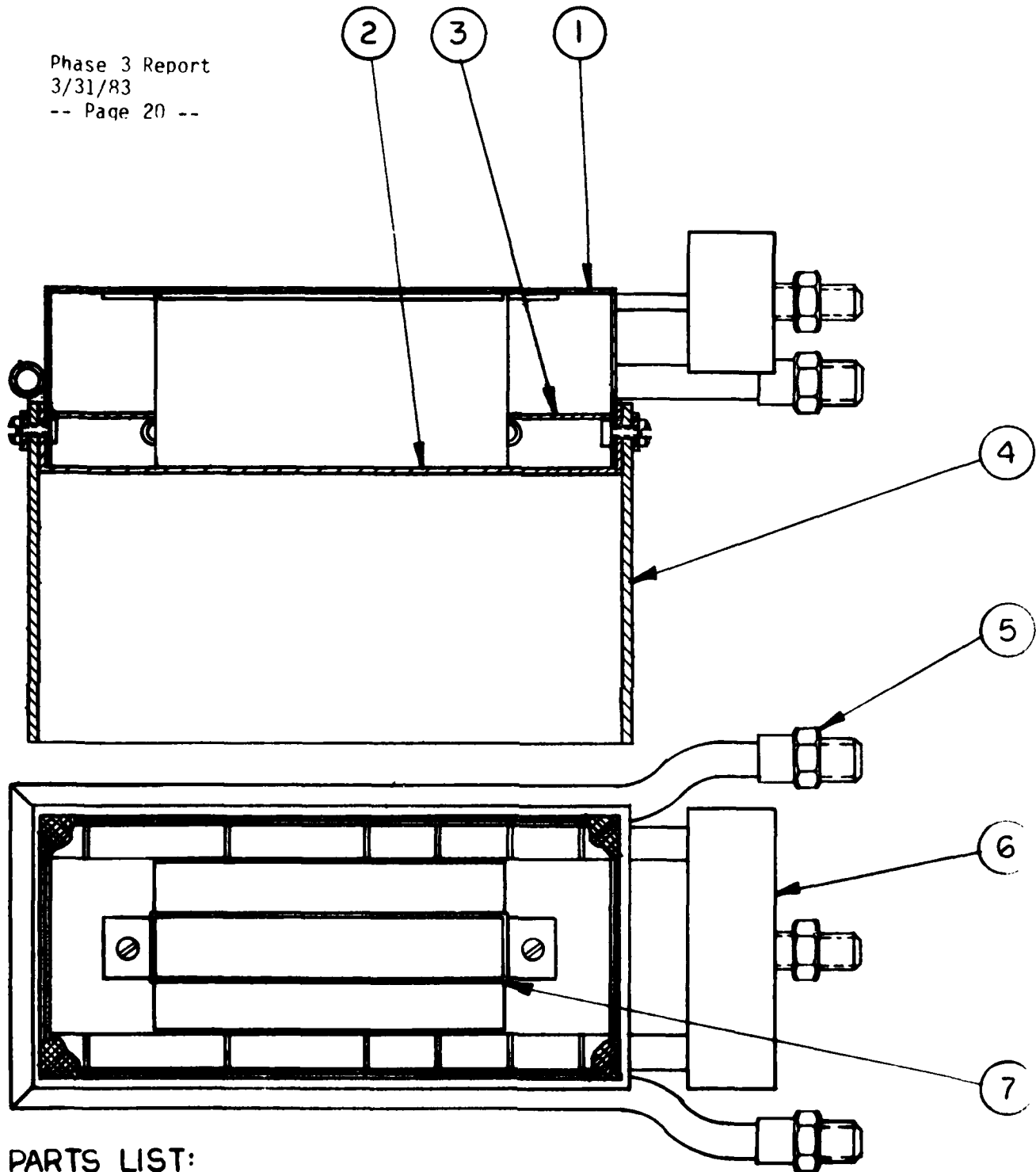

FIGURE 3



PARTS LIST:

- 1. GAS SHIELD
- 2. SPATTER SCREEN
- 3. GAS SCREEN
- 4. SKIRT
- 5. COOLANT TUBE
- 6. GAS TUBE
- 7. TORCH PASSAGE

GAS SHIELD ASSY.
FIGURE 4A

PARTS LIST:

- 1. GAS TUBE
- 2. COOLANT TUBE
- 3. TORCH MTG. BLOCK
- 4. TORCH BOWDEN TUBE
- 5. TIP HOLDER
- 6. WELDING TIP

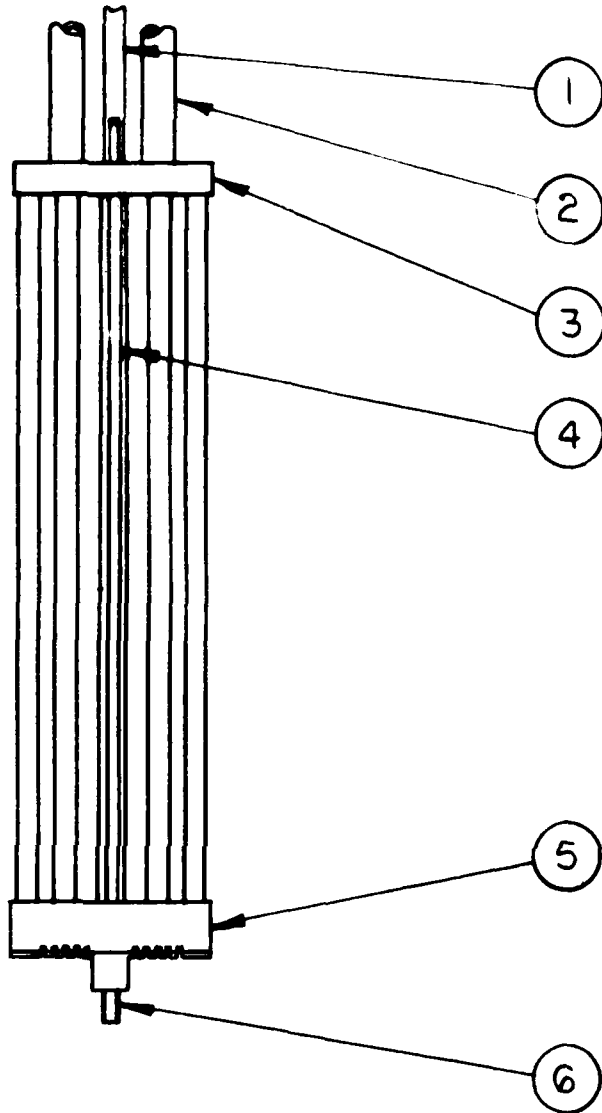

TORCH ASS'Y.
FIGURE 4B