

AD-A145 859

DEVELOPMENT OF OPTICAL TECHNIQUES FOR EARTH ROTATIONAL
MEASUREMENTS(U) MASSACHUSETTS INST OF TECH CAMBRIDGE
RESEARCH LAB OF ELECTRONICS S EZEKIEL APR 83

1/1

UNCLASSIFIED

AFGL-TR-84-0125 F19628-79-C-0002

F/G 1777

NL

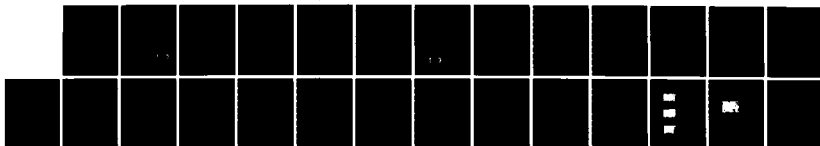

END

FILMED

DTIC

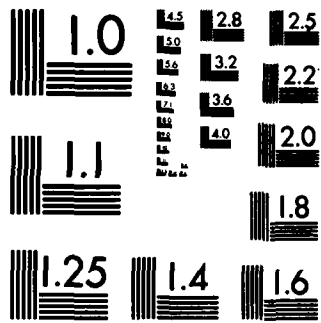

MICROCOPY RESOLUTION TEST CHART
NATIONAL BUREAU OF STANDARDS-1963-A

8

AFGL-TR-84-0125

AD-A145 859

DEVELOPMENT OF OPTICAL TECHNIQUES
FOR EARTH ROTATION MEASUREMENTS

Shaoul Ezekiel

Massachusetts Institute of Technology
Research Laboratory of Electronics
Cambridge, Massachusetts 02139

Final Report
1 February 1982 - 31 January 1983

April 1983

Approved for public release; distribution unlimited

DTIC FILE COPY

AIR FORCE GEOPHYSICS LABORATORY
AIR FORCE SYSTEMS COMMAND
UNITED STATES AIR FORCE
HANSCOM AFB, MASSACHUSETTS 01731

DTIC
ELECTE
SEP 21 1984

AZ

B

9 09 21 008

CONTRACTOR REPORTS

This report has been reviewed by the ESD Public Affairs Office (PA) and is releasable to the National Technical Information Service (NTIS).

This technical report has been reviewed and is approved for publication.

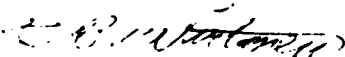

THEODORE E. WIRTANEN
Contract Manager

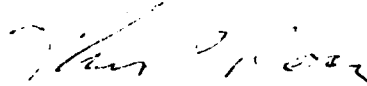

THOMAS P. ROONEY
Chief, Geodesy & Gravity Branch

FOR THE COMMANDER



DONALD H. ECKHARDT
Director
Earth Sciences Division

Qualified requestors may obtain additional copies from the Defense Technical Information Center. All others should apply to the National Technical Information Service.

If your address has changed, or if you wish to be removed from the mailing list, or if the addressee is no longer employed by your organization, please notify AFGL/DAA, Hanscom AFB, MA 01731. This will assist us in maintaining a current mailing list.

UNCLASSIFIED

SECURITY CLASSIFICATION OF THIS PAGE (When Data Entered)

REPORT DOCUMENTATION PAGE		READ INSTRUCTIONS BEFORE COMPLETING FORM
1. REPORT NUMBER AFGL-TR-84-0125	2. GOVT ACCESSION NO. AD-A145859	3. RECIPIENT'S CATALOG NUMBER
4. TITLE (and Subtitle) DEVELOPMENT OF OPTICAL TECHNIQUES FOR EARTH ROTATION MEASUREMENTS	5. TYPE OF REPORT & PERIOD COVERED Final Report Feb. 1, 1982 - Jan. 31, 1983	
	6. PERFORMING ORG. REPORT NUMBER	
7. AUTHOR(s) Shaoul Ezekiel	8. CONTRACT OR GRANT NUMBER(s) F19628-79-C-0082	
9. PERFORMING ORGANIZATION NAME AND ADDRESS Massachusetts Institute of Technology Research Laboratory of Electronics Cambridge, Massachusetts 02139	10. PROGRAM ELEMENT, PROJECT, TASK AREA & WORK UNIT NUMBERS 61102F 2309GLAU	
11. CONTROLLING OFFICE NAME AND ADDRESS Air Force Geophysics Laboratory Hanscom AFB, Massachusetts 01731 Monitor/T. E. Wirtanen/LWG	12. REPORT DATE April 1983	
	13. NUMBER OF PAGES 26	
14. MONITORING AGENCY NAME & ADDRESS (if different from Controlling Office)	15. SECURITY CLASS. (of this report) Unclassified	
	15a. DECLASSIFICATION/DOWNGRADING SCHEDULE	
16. DISTRIBUTION STATEMENT (of this Report) Approved for public release; distribution unlimited.		
17. DISTRIBUTION STATEMENT (of the abstract entered in Block 20, if different from Report)		
18. SUPPLEMENTARY NOTES		
19. KEY WORDS (Continue on reverse side if necessary and identify by block number) Passive ring interferometer Lasers Earth rotation measurements		
20. ABSTRACT (Continue on reverse side if necessary and identify by block number) The principal objective of the research program is the study of a passive ring cavity approach for the measurement of inertial rotation in the range 10^{-6} - 10^{-10} of earth rate. <i>10 to the minus 6th to 10 to the minus 10th</i>		

(a) SUMMARY OF OBJECTIVES

The principal objectives of the research program are the study of long term error sources in the passive resonator inertial rotation sensor and the measurement of Fresnel Drag in a ring resonator.

Brief Description of Progress

We have studied several sources of error in the passive resonator gyroscope. These include external beam misalignment, intra cavity polarization and back scattering effects. In particular, we have performed a careful study of the observed spatial variations in the resonance frequency of the resonator. The enclosed paper which will be published in the July 1983 issue of the Journal of the Optical Society of America describes the details of our study. In summary, we have found that the measured resonance frequency of our optical cavity depended on the size and position of the detector. This effect which is attributed to the presence of higher order transverse modes is due to the nonorthogonality of these modes when averaged over a limited aperture or an inhomogeneous detector surface. The results of our calculations are in good agreement with the experimental observations. In addition, we have investigated several possibilities for reducing such spatial effects.

The other effort in this reporting period has been the measurement of Fresnel Drag in our ring resonator. The

experimental setup involves oscillating a piece of glass back and forth along the laser beam within the resonator and measuring the resulting nonreciprocal frequency shift. In this way we have studied the dependence of the Fresnel Drag on velocity, length of the glass medium, refractive index and also the dispersion of the medium. A paper is presently being written on this subject.

(b) There was no equipment acquired during this reporting period of this contract.

(c) Personnel:

S. Ezekiel

G. Sanders

R. Meyer

(d) Travel expenses

There were no travel expenses during this reporting period of this contract.

(e) Difficulties encountered - None

(f) Plans for next reporting period - not applicable

(g) List of scientific reports and theses

S.M. Thesis

R.E. Meyer, "Study of Observed Spatial Variations in the Resonance Frequency of an Optical Resonator," January 1982.

Ph.D. Thesis

G.A. Sanders, "Measurement of Fresnel Drag Using a Passive Ring Resonator Technique," May 1983.

G.A. Sanders, M.G. Prentiss and S. Ezekiel, "Passive Ring Resonator Method for Sensitive Inertial Rotation Measurements in Geophysics and Relativity," Optics Letters, 6, 569, 1981.

R.E. Meyer, G.A. Sanders and S. Ezekiel, "Observation of Spatial Variations in the Resonance Frequency of an Optical Resonator," J. Optical Society of America, 73, 939, 1983.

G.A. Sanders and S. Ezekiel, "Measurement of Fresnel Drag in Moving Media Using a Ring Resonator Technique," in preparation.

RE: AFGL-TR-84-0125

Paper on Page 6 is a back up paper for first paper in report per Ms. Diane Corazzini, AFGL/SULR

S **DTIC**
ELECTE
SEP 21 1984
D
B



Accession For	
NTIS GRA&I	<input checked="" type="checkbox"/>
DTIC TAB	<input type="checkbox"/>
Unannounced	<input type="checkbox"/>
Justification	
By	
Distribution/	
Availability Codes	
Dist	Avail and/or Special
A-1	

OBSERVATION OF SPATIAL VARIATIONS
IN THE RESONANCE FREQUENCY OF AN OPTICAL RESONATOR

R.E. Meyer, G.A. Sanders and S. Ezekiel

Research Laboratory of Electronics
Massachusetts Institute of Technology
Cambridge Massachusetts 02139

ABSTRACT

The observation of a dependence of the measured resonance frequency of an optical cavity on the size and position of the detector is reported and attributed to the presence of higher order transverse modes in the cavity. This effect, which is due to the nonorthogonality of these modes when averaged over a limited aperture or an inhomogeneous detector surface, has been carefully studied. The results of our calculations are in good agreement with experimental observations. Methods of minimizing such frequency pulling effects are suggested.

Precise determination of the resonance frequency of an optical cavity is important in the development of devices such as inertial rotation sensors⁽¹⁾, gravity wave detectors⁽²⁾, and frequency stabilized lasers⁽³⁾. In a previous paper⁽¹⁾ on the use of a passive ring resonator for the detection of inertial rotation, we have noted that frequency pulling by higher order transverse modes can be a source of error in the determination of the cavity resonance. More recently, we have observed a much larger effect; the dependence of the measured resonance frequency of the cavity on the size and position of the photodetector used to measure the transmitted beam intensity⁽⁴⁾.

In this paper we report experimental measurements of the dependence of the resonance frequency of a two-mirror cavity⁽⁵⁾ on detector position and size. We also discuss the results of a theoretical calculation of this behavior and suggest ways of minimizing such spatial effects.

The experimental setup used in our studies is illustrated in Fig. 1. Light from a single frequency 100 μ w laser is directed into a two-mirror cavity, consisting of a flat input mirror and a spherical output mirror having a 5 cm radius of curvature. The input mirror is mounted on a piezo-electric crystal (PZT) and the cavity length is modulated at the reference frequency f_m by the PZT. The light transmitted through the cavity is split into two beams and directed onto two photodetectors (PD). The position of PD #1 is held fixed, and the diameter of the de-

tector surface is approximately 8 times the diameter of the beam, so essentially all the light in the beam is collected. On the other hand, PD #2 has an adjustable aperture mounted in front of it, and this detector-aperture assembly can be manually moved across the output beam.

Figure 2a illustrates the transmitted intensity as a function of cavity length. The large peaks are due to the TEM_{00} mode and the smaller peaks are due to the TEM_{10} mode (cylindrical coordinates). The separation of the 0-0 and 1-0 resonances is approximately 1/20 of the 3100 MHz free spectral range (F.S.R.) and is much larger than the 10 MHz width of the resonances.

As shown in Fig. 1, the outputs of both photodetectors are demodulated at f_m by phase-sensitive detectors (PSD). The PSD output as a function of cavity length is approximately a derivative of the resonance, the output being zero at the center of the resonance. In our experiments, the output of PSD #1 is used to lock the cavity resonance to the laser frequency with a conventional feedback loop⁽¹⁾, shown in Fig. 1. The output of PSD #2, which displays the variation of the resonance frequency with detector position, is recorded simultaneously with the output of PD #2.

Data was first taken with the aperture in front of PD #2 adjusted so that its diameter was approximately 0.4 of the beam diameter. Figure 3a shows the intensity measured by detector

#2 as a function of position along a horizontal line through the center of the beam. The measured intensity has a jagged appearance because the detector was moved manually in small, discrete steps. The dependence of the intensity on detector position is consistent with the Gaussian intensity distribution of the 0-0 mode. Figure 3b shows the corresponding output of PSD #2 as a function of detector position. It is definitely nonzero and varies with detector position even though the output of PSD #1 is zero. The data in Fig. 3b clearly demonstrates that the effective resonance frequency varies across the beam. The magnitude of the output is greatest at the center of the beam, corresponding to a frequency offset of -120 kHz relative to PSD #1. This procedure was repeated using a vertical scan, and the results are similar to that for the horizontal scan.

When the aperture in front of detector #2 was opened fully so that its diameter was much larger than the beam size, the output of PSD #2 changed to that shown in Fig. 4 as PD #2 was translated horizontally across the output beam. In this case, the measured frequency offset also depends on detector position, but stays within a range of 3.5 kHz. Comparison of Figs. 3b and 4 shows that the variation in effective cavity resonance frequency with detector position depends on the fraction of the beam that falls on the detector; the larger this fraction, the smaller is the frequency variation.

At first we attributed the resonance frequency variations with detector position to the presence of higher order modes in

the cavity. Therefore, we placed an aperture inside the cavity so that diffraction losses would attenuate higher order modes to a greater extent than the 0-0 mode. Figure 2b shows the total transmitted intensity as a function of cavity length with an aperture in the cavity. By comparison with Fig. 2a, it can be seen that the transmitted intensity at the resonance of the 0-0 mode was reduced to 0.8 of its value without the aperture, while the transmitted intensity at the resonance of the 1-0 mode was reduced to 0.25 of its former value. The effect of the aperture on frequency offsets is illustrated by Fig. 3c which shows the output of PSD #2 for a horizontal scan with the aperture in the cavity. The dependence of this output on detector position is similar to that of Fig. 3b; however, the frequency offset at the center of the beam is -132 kHz, which is slightly larger than the value without the aperture. Thus, although the presence of the aperture in the cavity reduced the size of higher order modes, it was ineffective in reducing the frequency offsets.

Even though these experiments suggest that higher order modes are not the cause of the spatially dependent offsets, we have performed a calculation which shows that the frequency offsets are indeed due to the interference of the higher order modes with the fundamental cavity mode. Under ideal conditions, the spatial orthogonality of the Gaussian cavity modes⁽⁶⁾ would preclude the interference of two cavity modes from causing a frequency shift, but it is the presence of an aperture before the detector or inhomogeneities in the detector surface that spoils this orthogonality condition.

We now give a simple discussion of how the frequency pulling comes about when the aperture before the detector is much smaller than the transmitted beam size. For simplicity we take into account only one higher order mode, the 1-0 mode (cylindrical coordinates); in most of our experiments this mode had much more light coupled into it than any other higher order mode. The total intensity, I , measured by this detector at a point P after the cavity, is given by

$$I = |E_{00}|^2 + |E_{10}|^2 + 2E_{00}E_{10} \cos(\phi_{00} - \phi_{10}) \quad (1)$$

where E_{00} and E_{10} are, respectively, the contributions at P of the electric field amplitudes of the 0-0 and 1-0 modes and ϕ_{00} and ϕ_{10} are the phases of these fields, respectively.

The magnitudes of E_{00} , E_{10} , ϕ_{00} , ϕ_{10} , and thus the total intensity I , clearly depend on the length of the cavity, i.e., the detuning of the modes from their respective resonances. As an illustration, Fig. 5a shows the electric field amplitude of an isolated cavity mode as a function of cavity length. The lineshape is given by the square root of the Airy function⁽⁷⁾

$$\left[1 + \frac{4R}{(1-R)^2} \sin^2 \frac{\delta}{2} \right]^{-1/2}$$

where R is the reflectivity of the cavity mirrors and δ is the round trip phase shift. The transmitted electric field reaches its maximum value E_m at resonance and drops off to a minimum of $(1-R)E_m/2$ for R close to 1. Figure 5b shows the phase of the transmitted electric field (with respect to its phase at the input mirror) as a function of cavity length⁽⁸⁾. As can be seen, the phase changes sharply across resonance from $(q\pi - \pi/2)$ to $(q\pi + \pi/2)$ radians, where q is the longitudinal mode number.

The magnitudes of E_{00} , E_{10} , and thus I , also depend on the location of the observation point P . Figures 6a and 6b show, respectively, the electric field amplitudes of the 0-0 and 1-0 modes as a function of the transverse position along any line passing through the center of the beam⁽⁶⁾. It should be noted that the field distribution of the 0-0 and 1-0 modes are cylindrically symmetric about the axis of the beam.

The general features of the spatial variations in the measured resonance frequency (Fig. 2b) can be understood by considering the contributions to the total intensity I given in Eq. 1. If there are no higher order modes present, the intensity would be just $|E_{00}|^2$, and the cavity resonance would coincide exactly with the 0-0 resonance. In the presence of the 1-0 mode for example, we get contributions from two additional terms, $|E_{10}|^2$ and $2|E_{00}||E_{10}| \cos(\phi_{00}-\phi_{10})$. If only the $|E_{10}|^2$ term is considered, the net effect is the familiar frequency pulling of the 0-0 resonance towards the 1-0 resonance.⁽¹⁾ The calculated magnitude of this pulling in our experiment is small, about 45 Hz, since the 1-0 resonance is well separated from the 0-0 resonance, as shown in Fig. 2a. It is the remaining contribution to the total intensity, namely the interference term $2E_{00}E_{10}\cos(\phi_{00}-\phi_{10})$, which accounts for the magnitude of the observed frequency offsets. We will now show how this interference term can pull the 0-0 resonance frequency and how the observed spatial dependence of the pulling comes about.

We begin by noting that the interference term depends on cavity length because the amplitudes and phases of the fields depend on length as shown in Fig. 5. For example, the size of the interference term in the case illustrated in Fig. 2a is approximately zero when the cavity is at the 0-0 resonance since $(\phi_{00} - \phi_{10}) = 90^\circ$. This comes about because $\phi_{00} = 0$ at the 0-0 resonance and the 1-0 mode is far enough from its resonance so that $\phi_{10} = -90^\circ$. As the cavity is tuned away from the 0-0 resonance, the magnitude of the interference term changes sharply because ϕ_{00} changes sharply (as shown in Fig. 5b) while ϕ_{10} remains at -90° . Therefore, the interference term is negative on one side of the 0-0 resonance and positive on the other side, thus causing an asymmetry in the transmitted intensity as a function of cavity length which leads to the pulling of the resonance frequency of the cavity. (The dispersion-like behavior of the interference term as a function of cavity length has been exploited recently by Wieman & Gilbert⁽⁹⁾ as an error signal for laser frequency stabilization.)

The magnitude of this interference term also depends on the position of the observation point P because, for any given cavity length, the product of the electric field amplitudes E_{00} and E_{10} varies with position as shown in Fig. 6c. Therefore, the frequency pulling due to the interference term will vary with detector position as determined by the function in Fig. 6c. Indeed, this predicted spatial variation is consistent with the data presented in Fig. 2b.

We have calculated the magnitude of the frequency pulling due to the interference term for the situation represented by

Fig. 2. For example, at the center of the beam, the calculated peak frequency offset is -107 kHz, as compared with the measured value of -120 kHz. This general agreement between the measured and calculated frequency offsets confirms the hypothesis that the spatial variations in resonant frequency are due to the interference term.

In order to explain why placing an aperture in the cavity did not reduce the spatial variations in resonance frequency, we have also calculated the effect of an aperture in the cavity. In this case, we assume a fraction $(1-A)$ of the intensity in a given mode is lost in each pass through the aperture; this reduces the peak transmitted electric field amplitude of the mode from E_m to $[(A)^{1/2} (1-R)/(1-RA)]E_m$ and the minimum off resonance amplitude to $[(A)^{1/2} (1-R)/(1+RA)]E_m$. It can be seen from these expressions that the on resonance electric field amplitude is much more sensitive to the presence of the aperture than the off resonance amplitude. Thus, the aperture can greatly attenuate a mode near resonance but has little effect on the transmission for a mode excited far from resonance.

In our experiments, the 1-0 mode was far from the 0-0 resonance, so we might expect that the aperture would have very little effect on the contribution of the 1-0 mode, and therefore the magnitude of the frequency offsets would remain the same. As a matter of fact, the measured peak offset (Fig. 3c) actually increased when an aperture was placed in the cavity. This may

be explained by the fact that the presence of the aperture, although it did not change the contribution of the 1-0 mode, it did, however, reduce the transmission of the 0-0 mode. Because of this, the attenuation of the interference term, $2E_{00}E_{10} \cos(\phi_{00}-\phi_{10})$, is not as large as that of $|E_{00}|^2$, and therefore the pulling effect due to the interference term is increased over the case without the aperture. For example, our calculations with the aperture included, predict a peak offset of -134 kHz which is greater than the predicted peak offset (-107 kHz) without the aperture. These calculations compare well with measured values of -132 kHz and -120 kHz, respectively.

In order to further test our hypothesis that the spatial variations in the resonance frequency are due to higher order modes, we conducted experiments in which we varied the magnitude of the coupling of the incident field into the higher order modes. We accomplished this by changing the cavity length while keeping the input field the same. This changed the cavity mode dimension, and therefore the coupling of the input beam into the various transverse cavity modes⁽⁶⁾. (It should be pointed out that changing the length of the cavity also changes the resonance frequencies of the modes.)

Measurements of the dependence of resonance frequency on detector position were performed at various cavity lengths and are summarized, along with corresponding calculations, in Table 1. The cavity lengths at which data was taken are indicated in

column 1, and the ratio of light coupled into the 1-0 and 0-0 modes, I_{10}/I_{00} , is given in column 2. For each cavity length, the 1-0 mode had more light coupled into it than any other higher order mode. As can be seen from the table, the least amount of light was coupled into the higher order modes at a cavity length of 4.75 cm, which corresponds to the mode-matched condition. The third column shows the ratio of the separation between the 0-0 and 1-0 resonances to the free spectral range. This column demonstrates that the separation of the modes increased as the cavity length was shortened. Columns 4 and 5, respectively, give the measured and calculated peak frequency offset without an aperture in the cavity, while columns 6 and 7 show the corresponding values of these offsets with an aperture in the cavity.

As can be seen from the table, the magnitude of the peak frequency offset is smallest at cavity lengths with the least amount of light coupled into higher order modes (i.e., near mode-matched condition). It should also be noted that the sign of the peak frequency offset changes as the cavity length is varied past the mode-matched length. While there is some discrepancy between the measured and calculated offsets, the calculations, however, do predict the general magnitude of the frequency offsets as well as the behavior with cavity length. Better agreement could probably be obtained by taking into account the pulling effect from other smaller higher order modes which were observed but neglected in our calculations.

In summary, we have shown that the presence of higher order modes in a cavity can cause a dependence of the measured resonance frequency on detector size and position. In principle, this effect can be eliminated by taking advantage of the spatial orthogonality of the modes by using a detector surface and optical components much larger than the beam size. In practice, the complete elimination of this effect cannot be accomplished because detector surfaces are not sufficiently homogeneous. Clearly, there are several options for further reduction of the effect. One is to eliminate higher order modes by matching the input beam as well as possible into the fundamental cavity mode, or to minimize the effect of the higher order modes by adjusting the cavity parameters in order to increase the separation of the 0-0 and higher order modes. Another option is to "homogenize" the output beam, for example, by passing the beam through, or scattering it from, a diffusing material, or by coupling the entire beam into a single mode fiber or a white cell. Alternatively, it may be possible to spin the detector about its axis to obtain the needed averaging.

This work was supported in part by the U.S. Air Force Geophysics Laboratory and by the National Science Foundation (PHY 810 9581).

References

1. S. Ezekiel, J.A. Cole, J. Harrison, and G. Sanders, "Passive Cavity Optical Rotation Sensor," SPIE vol. 157, p. 68-72, 1978.
2. R.W.P. Drever, et al, "Optical Cavity Laser Interferometers in Laser Spectroscopy V, p. 33-40, Springer Verlag, 1981.
3. J.L. Hall, et al, "Progress Toward Phase Stable Optical Frequency Standards," J. de Phys, C8, No. 12 pp. 59-71, December 1981.
4. G.A. Sanders, M.G. Prentiss, and S. Ezekiel, "Passive Ring Resonator Method for Sensitive Inertial Rotation Measurements in Geophysics and Relativity," Opt. Lett. 6, 569, 1981.
5. M. Hercher, "The Spherical Mirror Fabry-Perot Interferometer," Appl. Opt. 7, 951, 1968.
6. H. Kogelnik and T. Li, "Laser Beams and Resonators," Appl. Opt. 5, 1550, 1966.
7. M. Born and E. Wolf, Principles of Optics, Pergamon Press, 1970.
8. M. Prentiss, B. Peuse, and S. Ezekiel, "Interaction of Phase Modulated Laser Fields with Resonant Systems," Research Laboratory of Electronics Progress Report #123, Mass. Inst. of Tech. Jan. 1981.
9. C.E. Wieman and S.L. Gilbert, "Laser-Frequency Stabilization Using Mode Interference from a Reflecting Reference Interferometer," Opt. Lett. 7, 480, 1982.

Cavity Length (cm)	$\frac{I_{10}}{I_{00}}$	$\frac{ f_{10}-f_{00} }{\text{F.S.R.}}$	Peak Offset (kHz)			
			no aperture		with aperture	
			measured	calculated	measured	calculated
3.95	0.14	0.297	32 ± 3	43 ± 1	44 ± 4	59 ± 1.5
4.63	0.043	0.147	*	24 ± 1.5	21 ± 3	31 ± 2
4.70	0.034	0.124	*	24 ± 1.5	8 ± 3	30 ± 2
4.75	0.025	0.096	-13 ± 4	-25 ± 2	-8 ± 3	-32 ± 2.5
4.80	0.043	0.076	-21 ± 2	-40 ± 4	-29 ± 5	-50 ± 4.5
4.83	0.16	0.054	-120 ± 6	-107 ± 10	-132 ± 7	-134 ± 15
4.85	0.23	0.039	-160 ± 8	-174 ± 20	-210 ± 11	-280 ± 30

Table 1

Figure Captions

- Figure 1: Schematic diagram of experimental setup.
- Figure 2: Transmitted intensity as a function of cavity length. The large and small peaks correspond to the 0-0 and 1-0 modes respectively.
- (a) without an aperture in the cavity.
 - (b) with an aperture in the cavity.
- Figure 3: (a) Transmitted intensity as a function of detector position.
- (b) Output of PSD#2 corresponding to (a) with no aperture in the cavity.
 - (c) Output of PSD#2 as a function of detector position with an aperture in the cavity.
- Figure 4: Output of PSD#2 as a function of detector position with detector surface larger than beam.
- Figure 5: (a) Electric field amplitude as a function of cavity length.
- (b) Electric field phase as a function of cavity length.
- Figure 6: Electric field amplitude as a function of transverse spatial position
- (a) for 0-0 mode.
 - (b) for 1-0 mode.
 - (c) for interference term.

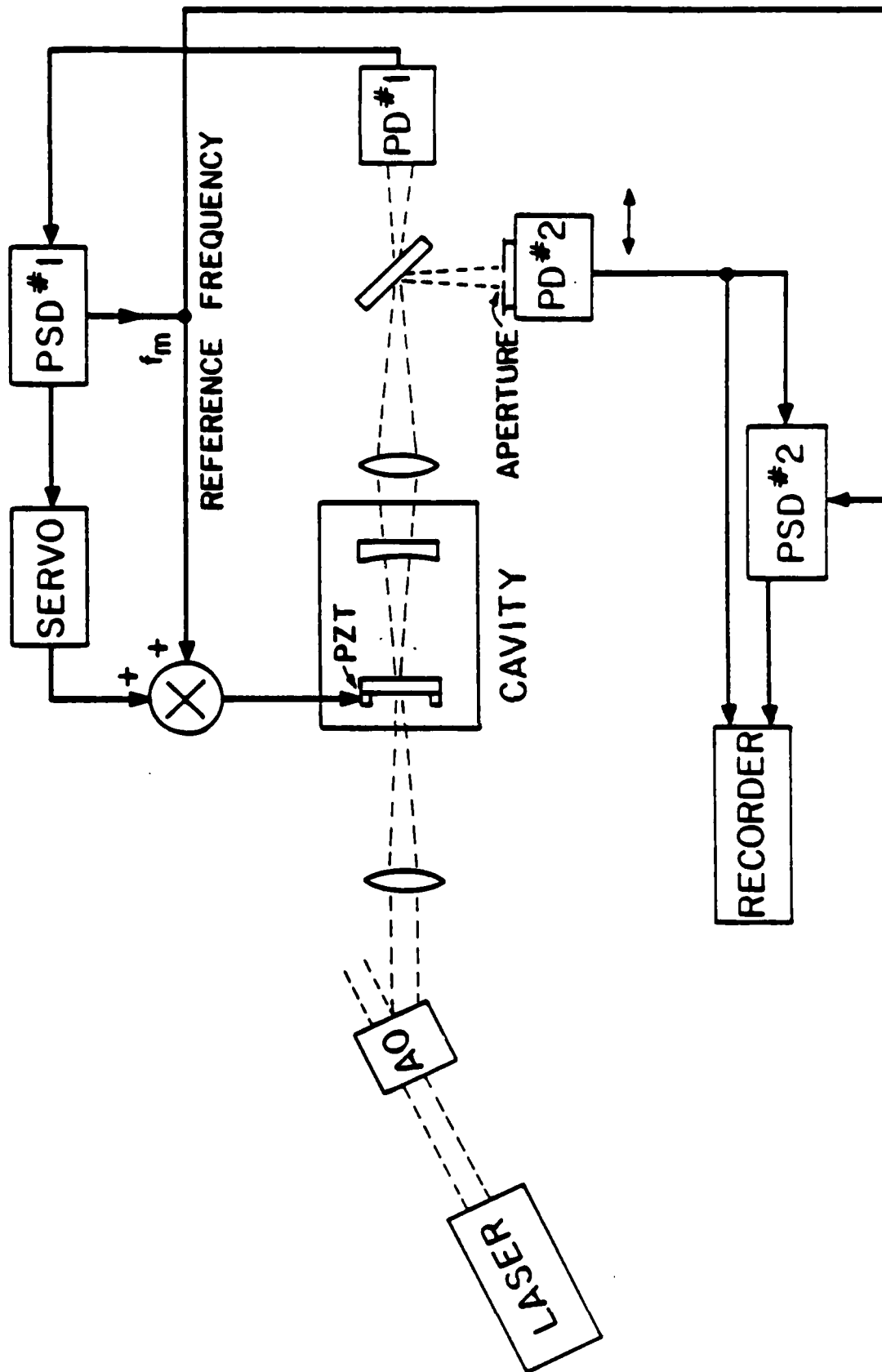
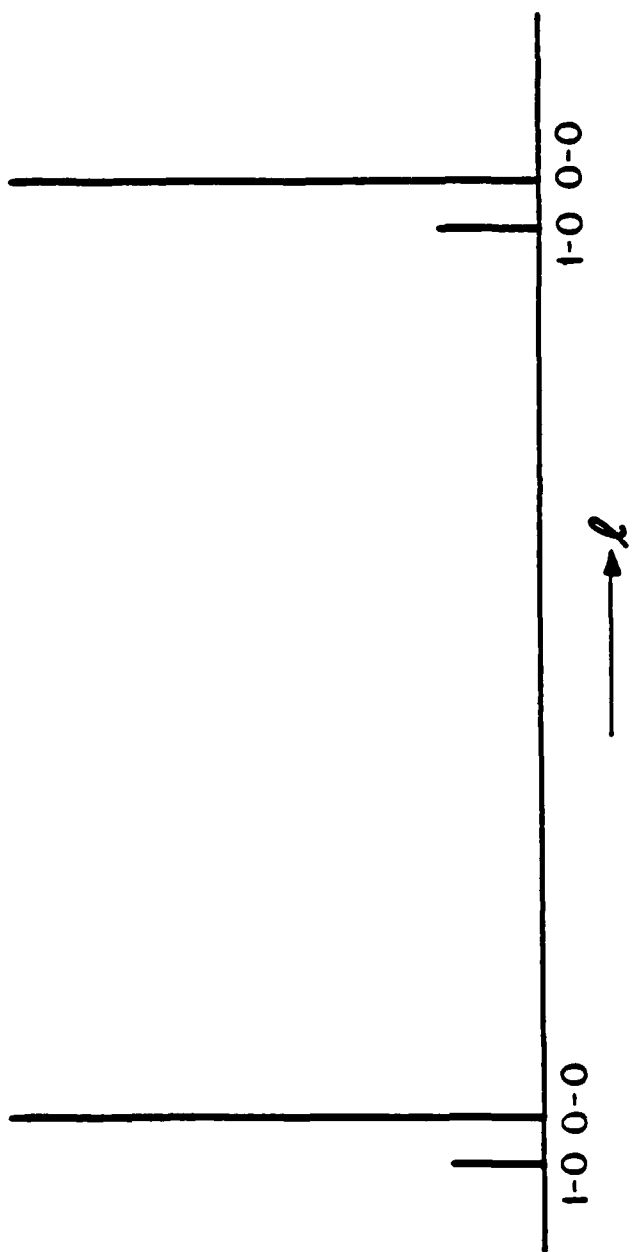
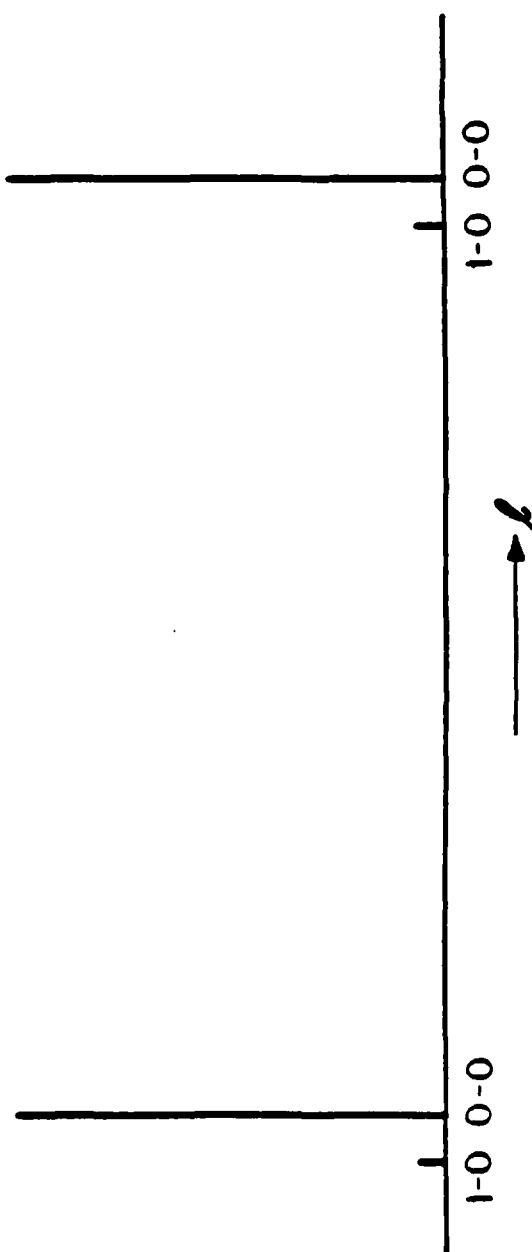

Figure 1



(a)



(b)

Figure 2

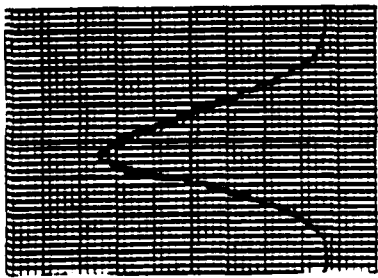

(a)

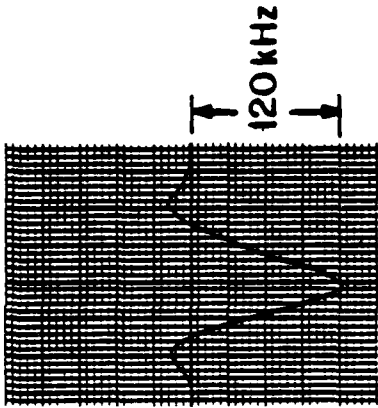

(b)

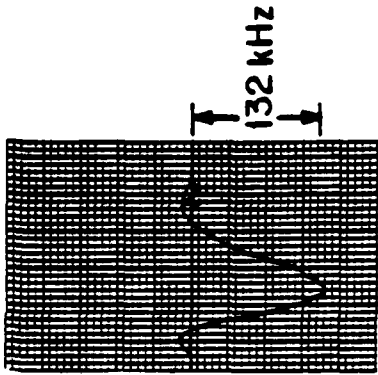

(c)

Figure 3

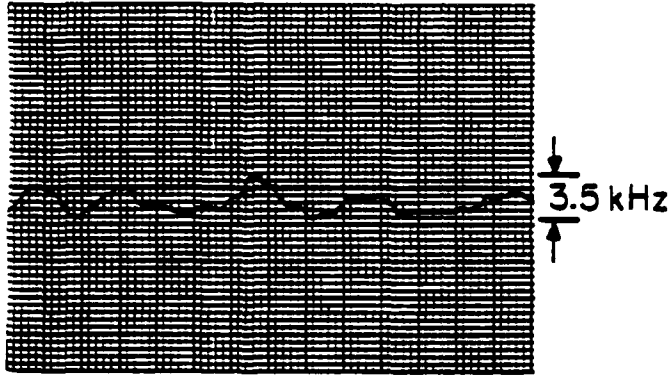
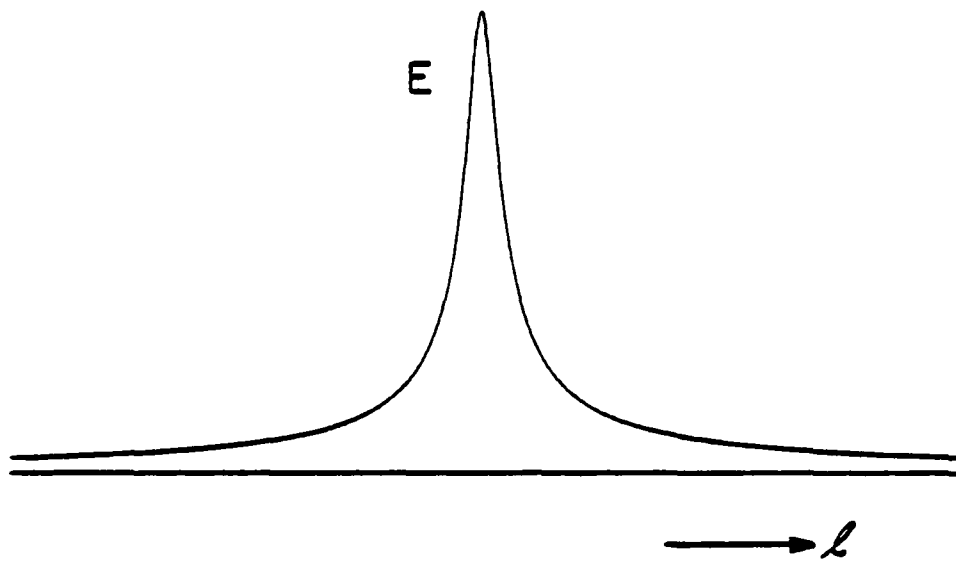
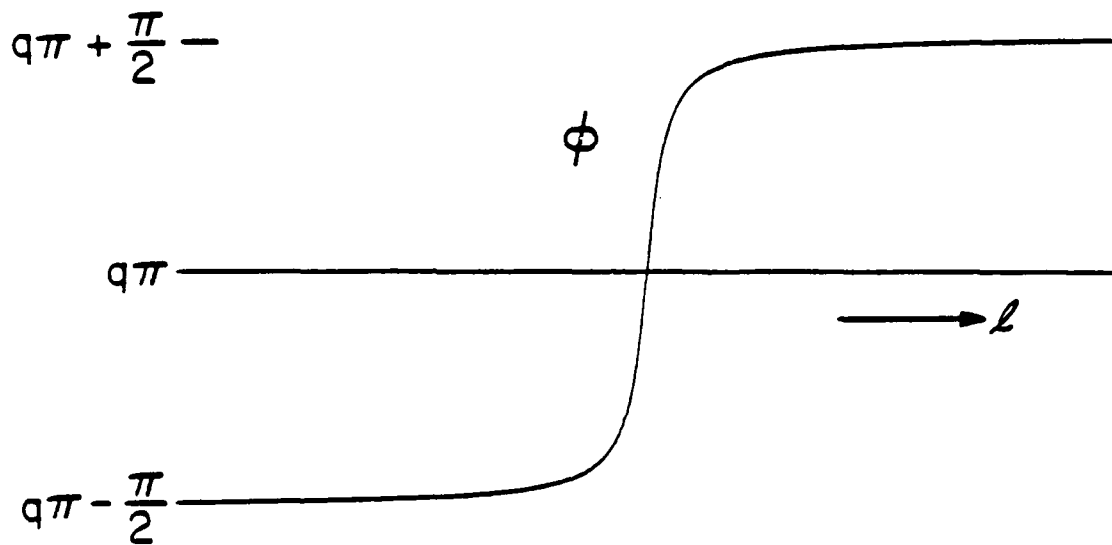

Figure 4



(a)



(b)

Figure 5

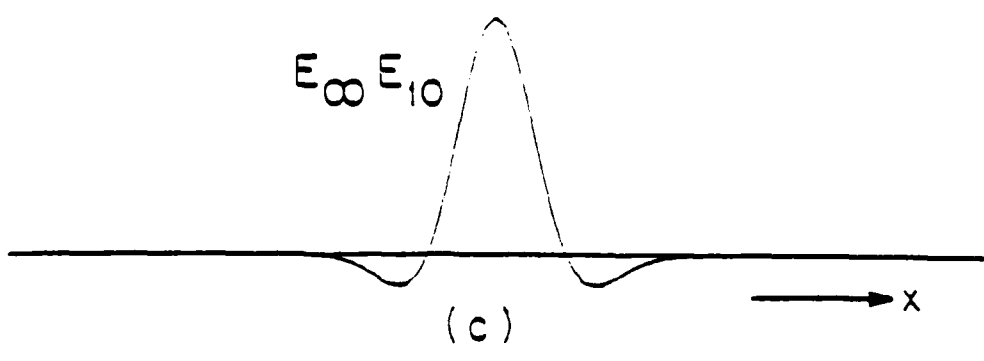
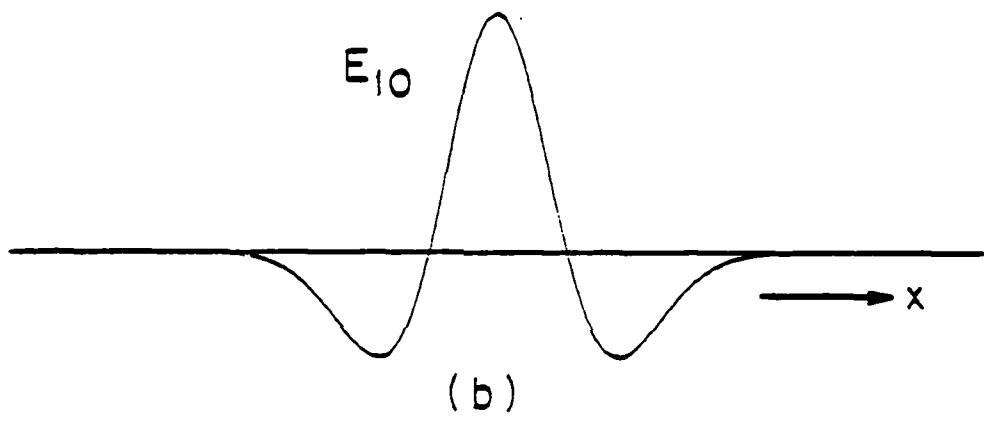
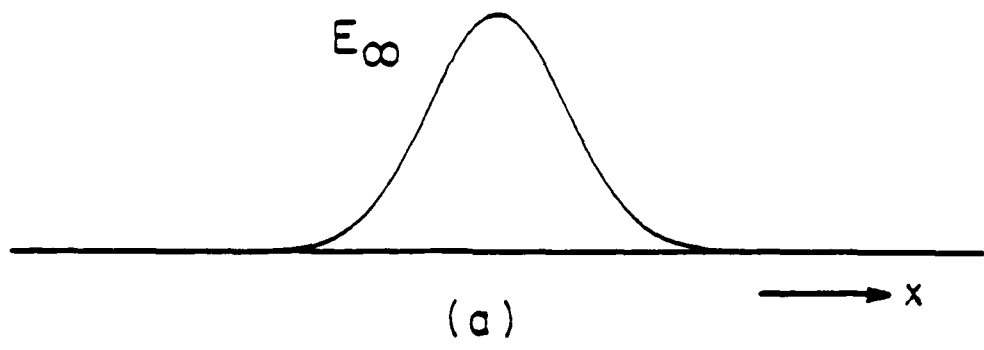

Figure 6

END

FILMED

10-84

DTIC