

MICROCOPY RESOLUTION TEST CHART

AD-A 146 050

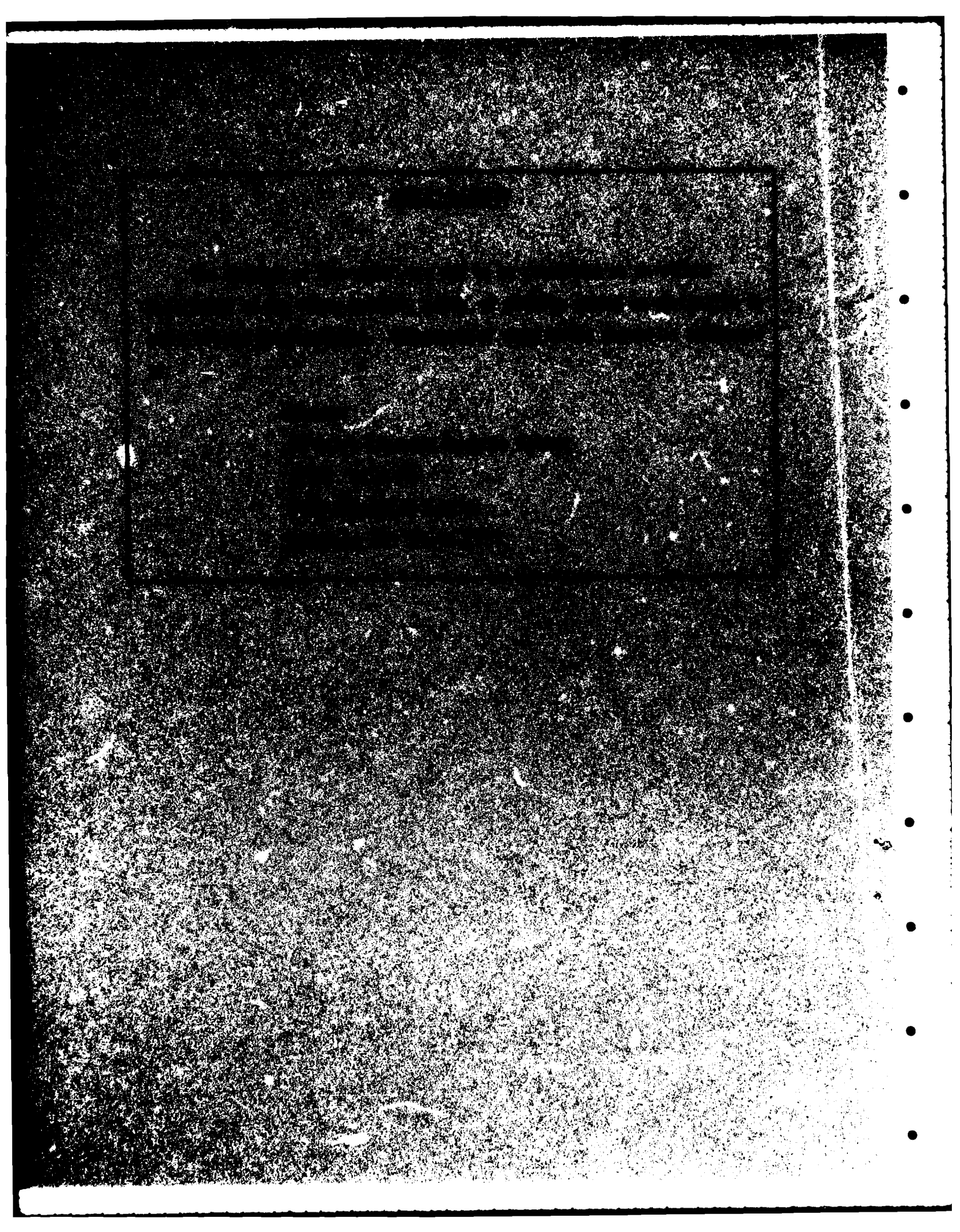

2

CAA-D-84-5

UNCLASSIFIED

SECURITY CLASSIFICATION OF THIS PAGE (When Data Entered)

REPORT DOCUMENTATION PAGE		READ INSTRUCTIONS BEFORE COMPLETING FORM
1. REPORT NUMBER CAA-D-84-5	2. GOVT ACCESSION NO. AD A146 050	3. RECIPIENT'S CATALOG NUMBER
4. TITLE (and Subtitle) Effective Date (E-DATE) Model Documentation Addendum to Reflect Model Enhancement	5. TYPE OF REPORT & PERIOD COVERED Final	
	6. PERFORMING ORG. REPORT NUMBER	
7. AUTHOR(s) James J. Connelly and Merle V. Lehmann	8. CONTRACT OR GRANT NUMBER(s)	
9. PERFORMING ORGANIZATION NAME AND ADDRESS US Army Concepts Analysis Agency 8720 Woodmont Avenue Bethesda, MD 20814-2797	10. PROGRAM ELEMENT, PROJECT, TASK AREA & WORK UNIT NUMBERS	
11. CONTROLLING OFFICE NAME AND ADDRESS Office of the Deputy Chief of Staff for Logistics (DALO-PLF) Washington, D.C. 20310	12. REPORT DATE August 1984	
	13. NUMBER OF PAGES 110	
14. MONITORING AGENCY NAME & ADDRESS (if different from Controlling Office)	15. SECURITY CLASS. (of this report)  UNCLASSIFIED	
	15a. DECLASSIFICATION/DOWNGRADING SCHEDULE	
16. DISTRIBUTION STATEMENT (of this Report)  Public release, distribution unlimited		
17. DISTRIBUTION STATEMENT (of the abstract entered in Block 20, if different from Report)  DTIC OCT 1 1984 A		
18. SUPPLEMENTARY NOTES		
19. KEY WORDS (Continue on reverse side if necessary and identify by block number) E-DATE Model, documentation, revision, change, enhancement		
20. ABSTRACT (Continue on reverse side if necessary and identify by block number) A compendium of changes has been developed for the Effective Date (E-DATE) Model documentation reflecting a set of enhancements incorporated into the model (see CAA-SR-84-17). The changes are extensive and are in the form of short text changes, extended text insets and new linework. It is anticipated that these changes will be incorporated into the standing model documentation. Reference should be made to the controlling office for the status of this documentation revision.		

DD FORM 1 JAN 73 1473

EDITION OF 1 NOV 65 IS OBSOLETE

UNCLASSIFIED

SECURITY CLASSIFICATION OF THIS PAGE (When Data Entered)

**EFFECTIVE DATE (E-DATE) MODEL  
DOCUMENTATION  
CHANGES TO REFLECT MODEL ENHANCEMENT**

**AUGUST 1984**

**PREPARED BY  
FORCE SYSTEMS DIRECTORATE  
AND  
MODELING DIRECTORATE**



**US ARMY CONCEPTS ANALYSIS AGENCY  
8120 WOODMONT AVENUE  
BETHESDA, MARYLAND 20814-2797**

A-1

## CONTENTS

CHAPTER		Page
1	INTRODUCTION .....	1-1
	Background .....	1-1
	Purpose .....	1-1
	Change Organization .....	1-2
	Change Identification .....	1-2
2	FUNCTIONAL DESCRIPTION UPDATES .....	2-1
	Text Changes .....	2-1
	Text Inserts .....	2-2
	New Linework .....	2-4
3	USER'S MANUAL UPDATES .....	3-1
	Text Changes .....	3-1
	Text Inserts .....	3-2
	New Linework .....	3-4
4	COMPUTER OPERATION MANUAL .....	4-1
	Text Changes .....	4-1
	Text Inserts .....	4-3
	New Linework .....	4-5
5	PROGRAM MAINTENANCE MANUAL UPDATES .....	5-1
	Text Changes .....	5-1
	Text Inserts .....	5-5
	New Linework .....	5-39
 <b>APPENDIX</b>		
A	Documentation Contributors .....	A-1
B	References .....	B-1
C	New Linework Functional Description .....	C-1
D	New Linework User Manual .....	D-1
E	New Linework Computer Operation Manual .....	E-1
F	New Linework Program Maintenance Manual, Tape Processor .....	F-1
G	New Linework Program Maintenance Manual, File Processor .....	G-1
H	New Linework Program Maintenance Manual, Assessment Processor .....	H-1
I	Distribution .....	I-1

**EFFECTIVE DATE (E-DATE) MODEL DOCUMENTATION**  
**ADDENDUM TO REFLECT MODEL ENHANCEMENT**

**CHAPTER 1**  
**INTRODUCTION**

**1-1. BACKGROUND.** The US Army Concepts Analysis Agency (CAA) was tasked by the Office of the Deputy Chief of Staff for Logistics (ODCSLOG) to enhance the capability of the E-DATE Model to achieve the following:

- a. Introduce unprogramed units into the force, in the fiscal year desired.
- b. Include equipment substitutions, identified in Total Army Equipment Distribution Program (TAEDP).
- c. Process units with no effective limit on the number processed.
- d. Interface readily with the user.

The necessary changes were incorporated into the E-DATE Model.<sup>1</sup> This document describes the changes necessary to the E-DATE Model documentation<sup>2-5</sup> to reflect the added capabilities. In addition, a separate volume of documentation<sup>6</sup> has been prepared to document the new (user request) processor which provides the user friendly interface with the E-DATE Model.

**1-2. PURPOSE.** This addendum provides update materials to be used by a publications staff to revise the documentation. It is not intended as a collection of change notices and change sheets to be used to update existing documentation. In particular, no provision has been made for necessary changes to section numbering and page numbering affected by the changes, or update of the table of contents, since these document features are normally accommodated by word processing. Rather, it is intended that these materials will be used to update the existing E-DATE Model documentation using the NBI diskette copies of the documentation provided by CAA to the Logistics Evaluation Agency (LEA). The NBI diskette format was previously selected for compatibility with the LEA word processing facility to facilitate changes of this sort. It is suggested that the changes in this document be used to mark up a copy of the current document to serve as a guide to the update of the word processing diskettes.

**1-3. CHANGE ORGANIZATION.** The changes are organized by documentation volume, i.e.,

- Volume I - Functional Description
- Volume II - User's Manual
- Volume III - Computer Operation Manual

- Volume IV - Program Maintenance Manual

Within each document, the changes are organized by type of change, i.e.,

- Text changes - word and phrase corrections and additions
- Text inserts - new lines, paragraphs, sections
- Linework inserts - replacements and additions of figures

#### 1-4. CHANGE IDENTIFICATION

a. Changes to the documentation are indicated by page and line number. The line number is a simple count of each printed line (or line segment) on a page, down to the line where the change appears. The count starts at the first printed entity, regardless of whether it is a heading, paragraph start, or continuation from the preceding page. The report number (which appears on each page) and blank lines are not included in the count. The "ff" abbreviation associated with some changes denotes "following." The reference to "Global" means all occurrences of change throughout text.

b. The "text changes" are enumerated in a change table for each document. These changes should be completed before addressing the insert changes. The "text inserts" are each assigned a label (e.g., FD-1, for Functional Description, insert number 1) and located in the text by page and line number. The label may be used to identify the change in the marked-up copy without actually transferring the text. The "linework inserts" for each volume are identified by the page in which the new material is to appear. Reference is made to the page in an appendix of this document where the new linework is reproduced. This linework is suitable for reproduction, once the appendix number is replaced with an appropriate text page number, assigned during the revision process.

## CHAPTER 2

## FUNCTIONAL DESCRIPTION UPDATES

## 2-1. TEXT CHANGES

Page	Line(s)	Change
1-1	16	follow with: "d. Supplement to Documentation for the Effective Date (E-DATE) Model"
1-1	17	"d." to "e."
1-1	18	"e." to "f."
2-1	19	"activations" to "adequacy of the equipment fill"
2-1	34	delete: ", in its present configuration,"
2-1	35	"two" to "three"
2-1	36	delete "The"
2-1	37	"other" to "Another"
2-2	5	"updates and unit" to "updates, unit"
2-2	6	"activations based" to "activations and unprogramed units based"
2-3	27	"by CTU" to "by CTU, unprogramed units"
2-6	27	"two" to "three"
2-6	20	"The other" to "Another"
2-6	22-24	delete: "The changes adjust . . . or unit readiness."
2-8	12	follow with: "● Supportability of Unprogramed Units"
2-9	16-18	delete "In its . . . storage limits"
3-1	9	"does not have" to "has a"
3-1	11	"equipment are" to "equipment, as identified in TAEDP, are"
3-1	11-13	"redistribution, but . . . substitute LIN." to "redistribution."
3-2	40-41	delete entirely: "A methodology . . . redistri-"
3-3	1-6	delete entirely: "bution . . . values."
3-4	29	"two" to "three"

## 2-2. TEXT INSERTS

FD-1 (page 2-1, line 3 from bottom, ff "... Table).")

The third grouping includes unprogramed units, that is, units proposed, but not as yet introduced (via TAEDP) into the logistically supported force.

FD-2 (page 2-3, ff line 35)

In addition to the three processors used to generate the rating results, the E-DATE has a fourth processor used to facilitate the interaction between the user and the model. This Request Processor employs a set of series to prompt the user for the information necessary to operate the other processors in their various modes of operation, including store and stop of operation.

FD-3 (page 2-6, line 22, ff ... (CTU).")

The third data set consists of unprogramed units (without assets) and associated billpayer units.

FD-4 (page 2-7, ff last line)

- Supportability of Unprogramed Units - the ODCSLOG can indicate the readiness of units proposed, but not as yet formally introduced (via TAEDP) into the logistically supported force. The generation of these new units and the equipment fill of these units is made by the model under user control.

FD-5 (page 2-9, ff last line)

The information on substitute items of equipment is taken from the TAEDP D-records. It is recognized that this data is derived from field units exercising their option to accept or reject an offered substitute item in lieu of the requested item. As such, the data is sensitive to actual unit-by-unit experience variations on the same equipment and in general is incomplete in indicating possible substitutes for all items of equipment where substitutes are available.

FD-6 (page 3-4, ff last line)

- User data

The user provides two files of data associated with the generation of unprogramed units. One file identifies the existing units which are to be the prototypes for the unprogramed units. The other file identifies those existing units (billpayer units) which are to provide the assets to fill the newly created units.

FD-7 (ff page 3-25 as left facing page)

### 3.3.2.11 Redistribution Units

Display: AP/13/

Description: This output provides the model user with a summary of the number of units involved in the redistribution process, by fiscal year. Counts are provided for units selected by worksheet and for units selected by use of the parameter specification.

Utilization: This output allows the user to be aware of the size of the pool of units being processed, and in particular, whether the number of units selected as a result of the parameter specification is as large as expected.

Sample Output: See Figure 3-11.

FD-8 (ff page 6-1, line 1)

Proposals have been made to further enhance the E-DATE Model in the following areas:

(1) Structuring and Implementation of Redistribution Criteria - the E-DATE Model presently requires the user to identify the units to be up-rated and downrated in order to carry out the redistribution. An inappropriate specification of these units especially will fail to accomplish the intended redistribution results and will require a subsequent run to further examine the situation. A preferred approach would be for the user to specify some general ground rules for the transfer and thereby allow the model to carry out one or more passes to arrive at the intended outcome. This implies a methodology development directed toward: (1) a more detailed statement of the issues involved in redistribution and (2) a more complex measure of unit readiness status which would include parameters to support the computation of the most appropriate candidates for asset redistribution.

(2) Data Base Access - the extensive file access and file generation carried out by the model requires that substantial system resources be dedicated to the model operation. Other applications operate similarly with the data elements involved. Much of the data, therefore, has a common use and could be made part of a generally accessible data base system. Work to define the data base system and the interface between the E-DATE Model and the data base is needed. Additionally, work may be needed to adapt the model to the computer system environment selected to host the data base, both with respect to the recompiling of the model FORTRAN code and the rewriting of the run control language.

CAA-D-84-5

2-3. **NEW LINEWORK.** New linework has been prepared to either replace existing linework or to be included as additional linework in the documentation. The linework is contained in Appendix C.

Current page

Action

2-5  
3-25

Replace with C-3  
Follow insert FD-7 with page C-5, as  
right facing page

CHAPTER 3  
USER'S MANUAL UPDATES

## 3-1. TEXT CHANGES

Page	Line	Change
GLOBAL	N/A	"TP1" to "TP2"
GLOBAL	N/A	"FP1" to "FP2"
GLOBAL	N/A	"AP1" to "AP2"
GLOBAL	N/A	"NEWUNT" to "ACTUNT"
GLOBAL	N/A	"CCTUNT" to "CHGUNT"
1-1	8	follow with: "c. Supplement to Documentation for the Effective Date (E-DATE) Model"
1-1	9	"c." to "d."
1-1	10	"d." to "e."
1-1	21	follow with: "D-RECORD the TAEDP record contains substitute data
2-1	12-14	delete: "It considers ... this period"
2-3	16-24	delete: "o Scans the master ... in subsequent processing"
2-3	8	"130K" to "160K"
2-3	10	"140K" to "170K"
2-6	4	delete "The model ... per execution" entirely
2-7	26	delete: "or, alternatively,"
2-7	1-8	delete para "e." entirely
2-7	28	"unit to select on both" to "user to select combinations of the"
2-7	22-33	"activated unit and changed unit TAEDP" to "Type Processor output"
2-7	27	"CTU." to "CTW and those units to be associated with unprogramed units"
3-1	all	replace all lines with entry: "Refer to Part II - User's Manual of the Effective Date (E-DATE) Model Documentation Supplement.6"
3-2 to 3-29	all	delete all lines
3-30	1-6	delete lines

### 3-2. TEXT INSERTS

UM-1 (page 2-1, line 12, ff "... POM years.")

The third grouping includes unprogramed units, that is, units proposed but not as yet introduced (via TAEDP) into the logistically supported force.

UM-2 (page 2-3, ff line 15)

- Selects, if specified by the user, the activated units throughout the 7-year planning cycle, based on the presence of an "A" indicator in the unit action code field
- Selects, if specified by the user, the units impacted by the CTU changes, based on the SRC list provided in the file corresponding to the Substantive Change Report
- Selects, if specified by the user, the units identified to be the prototypes for the unprogramed units and the units identified to be the billpayer units

UM-3 (page 2-8, ff bottom line)

- User data

The user provides two files of data associated with the generation of unprogramed units. One file identifies the existing units which are to be the prototypes for the unprogramed units. The other file identifies those existing units (billpayer units) which are to provide the assets to fill the newly created units.

UM-4 (page 3-31, ff line 12)

- Unprogramed Unit File

This file is the third of three major outputs from the Tape Processor and contains data on the unprogramed units and the billpayer units

UM-5 (ff page 3-77, left facing page)

### 3.3.2.22 Redistribution Units

Display: AP/13/

Description: This output provides the model user with a summary of the number of units involved in the redistribution process, by fiscal year. The counts are provided by units selected by worksheet and the units selected by user of the parameter specification.

Utilization: This output allows the user to be aware of the size of the pool of units being processed and in particular whether the number of units selected by the parameter specification is as large as expected.

Sample Output: See Figure 3-11.

CAA-D-84-5

3-3. **NEW LINWORK.** New linework has been prepared to either replace existing linework or to be included as additional linework in the documentation. The linework is contained in Appendix D.

Current page

Action

2-5

Replace with D-3

3-77

Follows page with UM-4 insert with page  
D-5 as right facing page

CHAPTER 4  
COMPUTER OPERATION MANUAL

## 4-1. TEXT CHANGES

Page	Line	Change
GLOBAL	N/A	"CCTLST" to "CHGLST"
GLOBAL	N/A	"PIKCCT" to "PIKCHG"
GLOBAL	N/A	"PIKNEW" to "PIKACT"
GLOBAL	N/A	"TP1" to "TP2"
GLOBAL	N/A	"FP1" to "FP2"
GLOBAL	N/A	"AP1" to "AP2"
1-1	12	follow with: "C. Supplement to Documentation for Effective Data (E-DATE) Model"
1-1	13	change: "c." to "d."
2-1	12-14	delete: "It considers ... this period."
2-2	19-28	delete: o Scans the master ... subsequent processing."
2-5	8	delete CHKLST line entirely
2-5	16	follow with: "DSYNP1 MTOE*TP2PRGOO DSYNP1 UNCLASSIFIED" "DSYNP2 MTOE*TP2PRGOO DSYNP2 UNCLASSIFIED"
2-5	23	follow with: "PIKNON MTOE*TP2PRGOO PIKNON UNCLASSIFIED"
2-5	24	delete RDUNT line entirely
2-5	24	follow with: "RDRQST MTOE*TP2PRGOO RDRQST UNCLASSIFIED" "TSTBIL MTOE*TP2PRGOO TSTBIL UNCLASSIFIED" "TSTNON MTOE*TP2PRGOO TSTNON UNCLASSIFIED"
2-5	24	"WRBCD MTOE*TP2PRGOO WRBCD UNCLASSIFIED"
2-5	24	"WRBLP MTOE*TP2PRGOO WRBLD UNCLASSIFIED"
2-5	24	"WRBLPA MTOE*TP2PRGOO WRBLPA UNCLASSIFIED"
2-5	27	follow with: "WRNONA MTOE*TP2PRGOO WRNONA UNCLASSIFIED"
2-5	29	follow with: "WSRCD MTOE*TP2PRGOO WSRCD UNCLASSIFIED"
2-6	15	follow with: "LOADD MTOE*FP2PRGOO LOADD UNCLASSIFIED"
2-6	18	follow with: "WRCNTS MTOE*FP2PRGOO WRCNTS UNCLASSIFIED"
2-6	22	follow with: "WRCLS MTOE*FP2PRGOO WRCLS UNCLASSIFIED"
2-6	22	"WRCNTS MTOE*FP2PRGOO WRCNTS UNCLASSIFIED"

Page	Line	Change
2-7	6	"BLDFIL" to "BLDADJ" (twice)
2-7	6	follow with: "BLDRTG MTOE*AP2PRG00 BLDRTG UNCLASSIFIED"
2-7	6	"BLDTRL MTOE*AP2PRG00 BLDTRL UNCLASSIFIED"
2-7	17	follow with: "DSYTRL MTOE*AP2PRG00 DSYTRL UNCLASSIFIED"
2-7	29	follow with: "RDRTS MTOE*AP2PRG00 RDRTS UNCLASSIFIED"
2-7	36	follow with: "TSTBUF MTOE*AP2PRG00 TSTBUF UNCLASSIFIED"
2-7	40	follow with: "WRRTG MTOE*AP2PRG00 WRRTG UNCLASSIFIED"
2-9	13-21	delete: "Two methods ... planning period."
3-1	11-15	delete: "o 'MLTUNT' - ... (CTU) data."
3-1	16	"NEWUNT" to "ACTUNT"
3-1	18	"the First Year Activated Units only" to "an Action Code of 'A' in the A-record."
3-1	19	"CCTUNT" to "CHGUNT"
3-1	21	"SRC Equipment Changes only." to "SRC Equipment Changes."
3-1	26	"NEWUNT" to "ACTUNT"
3-1	29	"CCTUNT" to "CHGUNT"
3-1	35	"NEWUNT" to "ACTUNT or NONUNT"
3-2	3	"NEWUNT" to "ACTUNT"
3-2	6	"CCTUNT" to "CHGUNT"
3-3	11	"files" to "file as follows:"
3-3	11-12	delete: "A separate ... as follows:"
3-3	13	"• MLTUNT - ..." to "MTOE*TP2DTA01"
3-3	14	delete entirely
3-3	15	delete entirely
3-3	18	"The three basic runs are" to "The basic run is"
3-3	19	"names:" to "name: TP2RUNE"
3-3	20-23	delete entirely
3-3	31	"runs are" to "run is"
3-3	31	"commands" to "command"

**4-2. TEXT INSERTS**

COM-1 (page 2-1, line 12, ff "... POM years")

The third grouping includes unprogramed units, that is, units proposed but not as yet introduced (via TAEDP) into the logistically supported force.

COM-2 (page 2-2, ff line 18)

- Selects, if specified by the user, the activated units throughout the 7-year planning cycle, based on the presence of an "A" indicator in the unit action code field
- Selects, if specified by the user, the units impacted by the CTU changes, based on the SRC list provided in the file corresponding the the Substantive Change Report
- Selects, if specified by the user, the units identified to be the prototypes for the unprogramed units and the units identified to be the billpayer units

COM-3 (page 2-8, ff line 6)

File Name	File ID	Storage medium	Required storage	Created by	Used by
Unprogramed units	DTACTL02	M/S	1,000	TP	FP
Billpayer units	DTACTL03	M/S	1,000	TP	FP

COM-4 (page 2-9, ff line 12)

Three methods are used by the model for selecting records from the TAEDP data. The data for activated units is selected using the Action Code on the unit A-record. All units with a code value of 'A' are selected. The data for the CTU impacted units is selected by comparing the SRC of the unit (on the A-record) with the SRC list of CTU units on Substantive Change Report file. The data for the unprogramed units is selected by (1) picking those units identified as prototypes by the user, and (2) picking those units identified as billpayers by the user.

COM-5 (page 3-1, ff line 21)

- NONUNT - This data set would be specified if the user desires to select unprogramed units from the TAEDP data

CAA-D-84-5

COM-6 (page 3-1, ff line 31)

- NONUNT - This run utilizes the Unprogramed Unit File created by the Tape processor

COM-7 (page 3-2, ff line 8)

- 'BASE' case 'NONUNT' - This run performs the initial ratings of all units in the Unprogramed Units File

COM-8 (page 3-2, ff line 11)

- 'TRIAL' case, 'NONUNT' - This run performs the equipment redistribution in order to fill the unprogramed units from the billpayer units utilizing the unit ratings created in the 'BASE' case run

**4-3. NEW LINEWORK.** New linework has been prepared to either replace existing linework or to be included as additional linework in the documentation. The linework is contained in Appendix E.

Current page

Action

2-4

Replace with E-3

## CHAPTER 5

## PROGRAM MAINTENANCE MANUAL UPDATES

## 5-1. TEXT CHANGES

Page	Line	Change
GLOBAL	N/A	"TP1" to "TP2"
GLOBAL	N/A	"FP1" to "FP2"
GLOBAL	N/A	"AP1" to "AP2"
GLOBAL	N/A	"CCTLST" to "CHGLST"
GLOBAL	N/A	"PIKCCT" to "PIKCHG"
GLOBAL	N/A	"PIKNEW" to "PIKACT"
1-1	23	follow with: "D-RECORD to The TAEDP record containing substitute data"
2-1	18	"two" to "three"
2-1	21	"The other" to "Another"
2-3	31	"27" to "37"
2-3	34-35	"Scans the master list for units activated in the planning cycle period to select units" to "Selects units activated in the planning period"
2-3	37	"Alternately, scans" to "Scans"
2-5	6	"23" to "27"
2-5	22	"38" to "44"
2-7	3	"27" to "37"
2-7	11	delete (CHKLST) entirely
2-7	19	follow with: "DSTNP1 DSTNP2"
2-7	26	follow with: "PIKNON"
2-7	28	delete "RDUNT"
2-7	28	add ff: "RDRQST TSTBIL TSTNON WRBCD WRBLP WRBLPA"
2-7	31	follow with: "WRNONA"
2-7	33	follow with: "WSRCD"
2-29	17	"TP1CTL01" to "DTACTL01"
2-29	18	"TP1TST00" to "MTO03041"
2-30	10	follow with: "● If unprogramed unit records selection is chosen, call PIKNON"
2-30	16	follow with: "● New Unit Summary (Report #7); see Figure 2-12"

		"● Billpayer Summary (Report #8); see Figure 2-13"
2-30	20	"TP1NEW40" to "TP2ACT40"
2-30	21	"TP1CCT40" to "TP2CHG40"
2-30	21	follow with:
		"● Unprogramed Unit File (MTOE * TP2NON40); Unit #14"
2-30	33	follow with:
		"● New Unit Summary (Report #7); see Figure 2-12"
		● Billpayer Summary (Report #8); so Figure 2-13"
2-31	5	follow with:
		"DSYNP1 ('FRST')('NEXT')('LAST')
		DSYNP2 ('FRST')('NEXT')('LAST')"
2-31	11	follow with 1
		"PIKNON"
		"RDUNT" to "PKSADV"
2-38	1-27	delete entirely
2-62	1-25	delete entirely
2-71	3	"23" to "27"
2-71	18	follow with:
		"LOADD"
2-71	21	follow with:
		"WRCNTS"
2-71	25	follow with:
		"WRCLS"
		"WRCNTS"
2-89	15	"New Activation Run (MTOE*FPICTLO1)" to "Activated Units
		or Unprogramed Units (MTOE*RITCTLO1"
2-89	16	"FPICTLO1" to "RTSCTLO2"
2-90	4	follow with:
		"● If record type = 'D' call LOADD"
2-90	30	follow with: "LOADD"
2-100	12	follow with:
		"● Read unit ID and record counts from storage"
2-100	28	follow with: "RDCNTS"
2-105	15	follow with:
		"● Store unit ID and records type counts"
		● Clear a and fl "
2-105	23	follow with: "WRCNTS"
2-119	3	"38" to "44"
2-119	9	"BLDFIL" to "BLDADJ"
2-119	9	follow with:
		"BLDRTG"
		BLDTRL"
2-119	20	follow with: "DSYTRL"
2-119	32	follow with: "RDRTG"
2-119	37	follow with: "TSTBUF"
2-119	43	follow with: "WRRTG"
2-152	20	"Call IOCTL(2)" to "Call ORDBUF and IOCTL(2)"
2-152	21	follow with:
		"● Display counts of units involved in redistribution"
2-152	30	"NEWUNT" to "NEWUNT or NONUNT"
2-152	32	"NEWUNT" to NEWUNT or NONUNT"
2-152	38	"Figure 7I" to "Figure 2-22"

2-152	39	"Figure 7J" to "Figure 2-23"
2-152	41	"Figure 7K" to "Figure 2-24"
2-152	43	"Figure 7L" to "Figure 2-25"
2-152	45	"Figure 7M" to "Figure 2-26"
2-152	47	"Figure 7N" to "Figure 2-27"
2-153	2	"Figure 7O" to "Figure 2-28"
2-153	3	"Figure 7P" to "Figure 2-29"
2-153	4	"Figure 7Q" to "Figure 2-30"
2-153	5	"Figure 7R" to "Figure 2-31"
2-153	6	"Figure 7S" to "Figure 2-32"
2-153	7	"Figure 7T" to "Figure 2-33"
2-153	7	follow with: "● Redistribution Units Report (Report #13, Figure 2-34)"
2-156	3	"BLDFIC" to BLDADJ"
2-193	3	"SAVRTG" to "WRRTS"
3-2	35-42	delete lines entirely
3-3	1-2	delete lines entirely
3-7	24	"155" to "180"
3-7	26	"Tape, File" to "File, Assessment"
3-8	4	follow with: "LINS(2) 76-81 & 83-88 A6 Substitute LIN NSUBFY 90 I1 Number LINS in FY"
308	5	"76-97" to "92-113"
3-8	6	"99" to "115"
3-8	7	"101" to "117"
3-8	8	"103" to "119"
3-8	9	"105-111" to "121-123"
3-8	10	"113-119" to "129-135"
3-8	11	"121-127" to "137-143"
3-8	12	"129-135" to "145-150"
3-8	13	"136-155" to "152-180"
3-11	2	"155" to "180"
3-11	16	follow with: "LINS(2) 76-81 & 83-88 A6 Substitute LIN NSUBFY 90 I1 Number LINS in FY"
3-11	17	"76-97" to "92-113"
3-11	18	"99" to "115"
3-11	19	"101" to "117"
3-11	20	"103" to "119"
3-11	21	"105-111" to "121-127"
3-11	22	"113-119" to "125-135"
3-11	23	"121-127" to "137-143"
3-11	24	"129-135" to "145-150"
3-11	25	"138" to "154"
3-11	26	"140" to "156"
3-11	27	"142" to "158"
3-11	29	"145" to "161"
3-11	30	"148" to "164"
3-11	31	"149-151" to "165-167"
3-11	32	"154" to "170"
3-11	33	"155" to "171"

CAA-D-84-5

3-11	33	follow with: "Not used 172-180"
4-1	13	change "index)" to "index"
4-1	13	follow with: "A through M - MACOM index)"
4-1	27	"each of the eight runstreams" to "each of the runstreams"
4-1	28	"processors. See Figures 4-1 through 4-8." to "Processors is shown in the Computer Operation Manual." 4-131"Figure 4-9(a) and 4-9(b)" to Figure 4-1(a) and 4- 1(b)"
4-1	33	"Figure 4-9(c) to Figure 4-1(c)"
4-2	6	"Figure 4-10" to "Figure 4-2"
4-2	11	"Figure 4-11" to "Figure 4-3"
4-3 to 4-20	N/A	delete lines entirely
4-21	4	"Figure 4-9(a)" to "Figure 4-1(a)"
4-21	7	"Figure 4-9(b)" to "Figure 4-1(b)"
4-21	26	"Figure 4-9(c)" to "Figure 4-1(c)"

## 5-2. TEXT INSERTS

PMM-1 page 2-1, line 23, ff "... (CCT).")

The third data set consists of the unprogramed units generated by the model, under user control.

PMM-2 (page 2-5, ff line 2)

- Generates a set of unprogramed units and a set of billpayer units by selection from the TAEDP data for analysis by the model

PMM-3 (page 2-14, ff line 9)

NONUNT IQT,RDATE,RID,RCODE,RBR,TYPBLP,BLPID,RMACOM,RAMO,RADMPL,  
RRNG,RCLAIM,NEWID,IFLG,UICHLD,TYPRCD,NPU,BPU,IRCNT,ICNT,  
AREC,BREC,IFCNT,JFLG,BUIC,JCNT,IHD,CLMHLD,MATBIL,MATNON,  
NDAMPL,UNISTT,SRCHLD

CAA-D-84-5

PMM-4 (page 2-17, see note)

NOTE - Each of the entries shown below are to be inserted into Table 2-2 at a location which preserves the alphabetic order of the entries on the table.

NAME	SUBROUTINE	SIZE	FMT	DESCRIPTION
AREC	PIKNON WRNONA WSRCD	N/A	I2	The counter for number of A-records of a unit in TAEDP array
BLPID	RDRQST TSTBIL DYSNP2	99	A9	Specific UIC, TOE, or SRC for requested billpayer unit
BPU	TSTBIL	N/A	I2	It is the subscript for the request arrays of billpayer units indicating match
CLMHL D	TSTNON PIKNON	N/A	A21	When request and match with TAEDP are made, positions 124-144 are put in hold
CLVL	PIKNON DYSNP2	N/A	A6	TAEDP record pos 1-6
ICNT	RDRQST TSTNON	N/A	I2	The counter for the number of nonprogramed units requested
IHD	RDRQST PIKNON	N/A	I2	Flag to control call to DSYNP1 to put headers on Unit #17 and Unit #18
IQY	RDRQST WSRCD	99	I2	Number of nonprogramed units requested
JCNG	RDRQST TSTBIL	N/A	I2	The counter for number of billpayer units requested
MATBIL	TSTBIL PIKNON RDRQST	N/A	I2	=0 means no match =1 means billpayer match
MATNON	TSTNON PIKNON RDRQST	N/A	I2	=0 means no match =1 means nonprogramed unit match
NDAMPL	RDRQST DSYNP1	99	I5	DAMPL, user request file for nonprogramed unit

NEWID	WSRCD TSTNON DSYNP1	99	A6	The overlay UIC of selected nonprogramed units. It is composed of RCODE and IQY
NPU	TSTNON WSRCD DSYNP1	N/A	I2	It is the subscript for the request arrays of nonunits indicating a TAEDP match
RALO	RDRQST TSTBIL	99	A1	ALO of requested billpayer unit
RBR	RDRQST TSTBIL DSYNP2	99	A2	Branch of requested billpayer unit
RCLAIM	RDRQST TSTBIL DSYNP1	99	A21	Claimant of selected nonprogramed unit
RCODE	RDRQST WSRCD	2,99	A2	Four leftmost digits of new UIC for selected nonprogramed units
RDAMPL	RDRQST TSTBIL DSYNP2	2,99	I5	DAMPL of requested billpayer unit
RDATE	None RDRQST WRNONA DSYNP1	99	I2	Effective date for selected nonprogramed units
RID	RDRQST DSYNP1 TSTNON	99	A6	UIC of requested nonprogramed unit
RMACOM	RDRQST TSTBIL DSYNP2	99	A3	Rightmost three digits of major command of requested billpayer unit
RRNG	RDRQST TSTBIL DSYNP2	99	I5	Range of requested billpayer unit
SRCHLD	TSTBIL DSYNP2	99	A9	TAEDP SRC, pos 185-193 of matching record
TAEDPA	PIKNON TSTBIL WRNONA	7	A239	Array of A-records for the current unit

CAA-D-84-5

TYPBLP	RDRQST TSTBIL DSYNP2	99	A1	Type billpayer requested, 'U' (UIC), 'T' (TOE), 'S' (SRC)
TYPRCD	PIKNON	N/A	A1	Position 34 of TAEDP record type record: A, B, C, or D
UNTSTT	PIKNON	N/A	I2	=1 means test new/next unit =2 means match of nonunit or billpayer, process unit =3 means no match, do not process unit
UICHLD	RDRQST PIKNON	N/A	A6	Holds the UIC of the current unit. Used as a flat for the first/next unit

PMM-5 (page 2-29, ff line 17)

- Prototype Units (MTOE\*DTACTLØ2); Unit #4
- Billpayer Units (MTOE\*DTACTLØ3); Unit #8

CAA-D-84-5

PMM-6 (ff page 2-38)

2.4.xx Program Description

a. Identification

Tape processor - CHKSPC

b. Functions. This subroutine accesses a list of special units input via "RDSPC" and tests whether the unit ID of the current record is a member of this list, and if so, flags the unit for processing to the special unit output file.

c. Input

Common blocks XCONTRL, XINPUT

d. Processing. This subroutine tests the unit ID against those IDs in the special unit test. If a match is found,

- Increase the special unit counter by one
- Return

If a match is not found in list, take numbered return.

e. Output

Method of return, i.e., in-line or numbered

f. Interfaces

Called by: PIKSPC

Calls to: none

g. Arguments

A return via the numbered return corresponds to a failure to achieve a match.

h. Tables and Items. Please refer to Table 2-2 for the Data Dictionary.

PMM-7 (ff page 2-50)

2.4.xx Program Description

## a. Identification

Tape processor - DSYNP1

b. Functions. This program displays nonprogramed units selected  
in TSTNON

## c. Input

Common blocks XNONUNT, XRDC, XCONTRL

## d. Processing. The processing of DSYNP1 is described as follows:

DSYNR=7

If the STATUS parameters equal 'FRST', CALL DSYCTL(DSYNR) to  
print the header on the first page.

If the STATUS parameter equals 'NEXT', write the following to  
Unit #17, print file for nonprogramed units:

RID(NPU)	A6	Prototype UIC
NEWID(NPU)	A6	Overlay identification (UIC)
RDATE(NPU)	I2	Effective date of new unit
NDAMPL(NPU)	I5	
RCLAIM(NPU)	A21	Claimant from matching TAEDP unit

NPU is the pointer for the nonunit request arrays showing  
match.

If STATUS parameter is equal to 'LAST', call WRCLS(DSYNR) to  
print classification at the end of the file.

## e. Output

Print file Unit #17

## f. Interfaces

Called by: PIKNON, WSRCD

Calls to: DSYCTL, WRCLS

## g. Arguments

Status - 'FRST', 'NEXT', 'LAST'

h. Tables and Items. Please refer to Table 2-4 for the Data  
Dictionary.

2.4.xx Program Description

a. Identification

Tape processor - PIKNON

b. Functions. This subroutine is the driver module for the non-programed unit enhancement of the E-DATE module. The functions performed include collecting the A-records of a unit, testing the A-records against user criteria for selecting nonprogramed units, and/or user criteria for selecting billpayer units. On the basis of the test(s), the status of the unit is determined: (1) records for the unit are not processed, (2) records are processed as nonprogramed units and/or billpayer units. A final function is writing selected units to print files and to a disk file for further processing.

c. Input

Common blocks - XRCO, XNONUNT

d. Processing. The processing of PIKNON is described as follows:

- Call DSYNP1 ('FRST') to write page headings for Report #12, the nonprogramed unit report
- Call DSYNP2 ('FRST') to write page headings for Report #13, the billpayer unit report
- Identify the first/next unit by the record UIC in positions 1-6
- Accumulate the A-records for the unit in the TAEDPA array
- Call TSTNON to test the A-records against the nonprogramed unit criteria in the user request file, DACTLO2
- Call TSTBIL to test the A-records against the billpayer unit criteria in the user request file, DACTLO3
- Determine unit status on the basis of switches TSTNON and TSTBIL
  - If the unit is a nonprogramed unit:
    - Call WRNONA to dump the TAEDPA array to Unit #13
    - Call WRBCD to write the B-records, the C-records, and the D-records to Unit #13
  - If the unit is a billpayer unit:

Called by: PIKNON, WRBLPA, WRBLP

Calls to: DSYCTL, WRCLS

g. Arguments

Status - 'FRST,' 'NEXT,' 'LAST'

h. Tables and Items. Please refer to Table 2-2 for the Data Dictionary.

PMM-9 (ff page 2-60)

2.4.xx Program Description

a. Identification

Tape processor - PIKNON

b. Functions. This subroutine is the driver module for the non-programed unit enhancement of the E-DATE module. The functions performed include collecting the A-records of a unit, testing the A-records against user criteria for selecting nonprogramed units, and/or user criteria for selecting billpayer units. On the basis of the test(s), the status of the unit is determined: (1) records for the unit are not processed, (2) records are processed as nonprogramed units and/or billpayer units. A final function is writing selected units to print files and to a disk file for further processing.

c. Input

Common blocks - XRCD, XNONUNT

d. Processing. The processing of PIKNON is described as follows:

- Call DSYNP1 ('FRST') to write page headings for Report #12, the nonprogramed unit report
- Call DSYNP2 ('FRST') to write page headings for Report #13, the billpayer unit report
- Identify the first/next unit by the record UIC in positions 1-6
- Accumulate the A-records for the unit in the TAEDPA array
- Call TSTNON to test the A-records against the nonprogramed unit criteria in the user request file, DTACTION2
- Call TSTBIL to test the A-records against the billpayer unit criteria in the user request file, DTACTION3
- Determine unit status on the basis of switches TSTNON and TSTBIL
  - If the unit is a nonprogramed unit:
    - Call WRNONA to dump the TAEDPA array to Unit #13
    - Call WRBCD to write the B-records, the C-records, and the D-records to Unit #13
  - If the unit is a billpayer unit:

- Call WRBLPA to write information to Unit #18, print file
- Call WRBPL to write the B-records, the C-records, and the D-records to Unit #14
- When a different unit is identified on the basis of UIC:
- Call WSRCD to process the unit records in Unit #13 according to user request specifications in DTACTION2

e. Output

f. Interfaces

Called by: MAIN

Calls to:	TSTNON	DSYNP1	WRNONA	WRBLPA	WSRCD
	TSTBIL	DSYNP2	WRBCD	WRBLP	

g. Arguments

h. Tables and Items

Please refer to Table 2-2 for the Data Dictionary.

2.4.24 Program Description

a. Identification

Tape processor - RDRQST

b. Functions. This subroutine reads disk file DTACTION2, containing the user specifications for introducing new units into the force and reads disk file DTACTION3, identifying those units in the force from which assets are to be taken (the billpayer units) to fill the equipment needs of the new units.

c. Input

Common blocks - XNONUNT

d. Processing. The processing of RDRQST is described as follows:

Output files are defined: Unit #13, scratch file for storing all the records of a unit identified as a nonprogramed unit. Unit #14, disk file for both nonprogramed units and billpayer units. This file is the interface for additional E-DATE Model processing.

The following data fields are input from DTACTION2:

RID(I)	A6	Prototype UIC
IQY(I)	I2	Quantity of new units
RCODE(1,I), RCODE(2,I)	2A2	New identification for unit
RDATE(I)	I2	Effective date for unit
NDAMPL	I5	

ICNT is the counter for the number of nonunits requested.

The following fields are input from DTACTION3:

TYPBLP(I)	A1	Record type
BLPID(I)	A10	UIC, TOE, or SRC
RMACOM	A3	Right-justified three digits of MACOM
RALO	A1	
RBR	A2	Unit branch
RDAMPL	I5	
RRNG	I5	Range

JCNT is the counter for the number of billpayer units requested.

e. Output - None

f. Interfaces

Called by: MAIN

Calls to: None

g. Arguments

h. Tables and Items. Please refer to Table 2-2 for the Data Dictionary.

PMM-11 (ff page 2-62)

2.4.xx Program Description

a. Identification

Tape processor - RDSPC

b. Functions. This subroutine reads in a list of user identified special units.

c. Input

Unit #10

d. Processing. A formatted read is made of each record containing a special unit ID. The read terminates when the end of the input file is reached.

e. Output

Common block XINPUT

f. Interfaces

Called by: MAIN

Calls to: None

g. Arguments: None

h. Tables and Items. Please refer to Table 2-2 for the Data Dictionary.

PMM-12 (ff page 2-62)

## 2.4.xx Program Description

### a. Identification

Tape processor - TSTBIL

b. Functions. This subroutine tests the current TAEDP record against information provided by the User Request File Unit #8 for billpayer units. A match of the criteria with any one of the A-records for a unit is sufficient to identify the unit as a billpayer unit.

### c. Input

Common blocks - XNONUNT, XRCB

d. Processing. The processing of TSTBIL is described as follows:

- The following local variables are used to test the TAEDPA record:

```

CLVL      = TAEDPA(K)(1:6)
TYPRCD    = TAEDPA(K)(34:34)
BSRC      = TAEDPA(K)(185:193)
BTOE      = TAEDPA(K)(188-193)
BMACOM    = TAEDPA(K)(7:12)
CMPMAC    = TAEDPA(K)(10:12)
BALO      = TAEDPA(K)(194:194)
BBR       = TAEDPA(K)(166:167)
BVAR      = TAEDPA(K)(65:69),

```

where K=1, AREC, and AREC is the counter for the number of A-records in the unit.

- Each record in the TAEDPA array is compared with the user criteria stored in arrays at the time Unit #8 was read in. CLVL, BSRC, BTOE are compared to BLPID(I).
- If any one of the three is a match, further compares are made. CMPMAC is tested for a match with RMACOM(I) BALO is tested for a match with RALO(I) BBR is tested for a match with RBR(I) BDAMPL must be between RDAMPL(I) and RRND(I)
- If a match is found, BPU is set to communicate the position in the user-criteria arrays, where the match occurred, and MATBIL is set to 1
- If no match occurs, MATBIL=0

### e. Output

CAA-D-84-5

f. Interfaces

Called by: PIKNON

Calls to: None

g. Arguments

h. Tables and Items. Please refer to Table 2-2 for the Data Dictionary.

PMM-13 (ff page 2-62)

2.4.xx Program Description

a. Identification

Tape processor - TSTNON

b. Functions. This subroutine tests the first A-record of the unit against the array of prototype UICs created when the User Request File for nonprogramed units was read in. Any match of the TAEDP UIC is sufficient to select the unit as nonprogramed.

c. Input

Common blocks - XNONUNT, XRCD

d. Processing. The processing of TSTNON is described as follows:

- The UIC is in positions 1-6 of TAEDPA(1) and the PROTO UIC is in the array RID
- If a match occurs, the switch TSTNON is set to 1, NPU is set to the position where the match was found, and positions 124-144 of TAEDPA(1) are stored in RCLAIM(NPU)
- If no match occurs, TSTNON=0

e. Output - none

f. Interfaces

Called by: PIKNON

Calls to: None

g. Arguments

h. Tables and Items. Please refer to Table 2-2 for the Data Dictionary.

CAA-D-84-5

PMM-14 (ff page 2-62)

2.4.xx Program Description

a. Identification

Tape processor - WRBCD

b. Functions. This subroutine writes the B-, C-, and D-records associated with a selected nonprogramed unit to a scratch file for use in subsequent processing.

c. Input

Common blocks - XNONUNT, XRCD

d. Processing. The processing of WRBCD is described as follows:

- Blank selected fields in record
- Write record to Unit #13

e. Output

Record to Unit #13

f. Interfaces

Called by: PIKNON

Calls to: None

g. Arguments

h. Tables and Items. Please refer to Table 2-2 for the Data Dictionary.

PMM-15 (ff page 2-62)

2.4.xx Program Description

a. Identification

Tape processor - WRBLP

b. Functions. This subroutine writes B-records, C-records, and D-records of a selected billpayer unit to Unit #14, disk file interface.

c. Input

Common blocks

d. Processing. The processing of WRBLP is described as follows:

TYPRCD=RECORD(34:34)

A check of record type is made. B-records, C-records, and D-records of a unit selected as a billpayer are output to Unit #14.

e. Output

f. Interfaces

Called by: PIKNON

Calls to: None

g. Arguments

h. Tables and Items. Please refer to Table 2-2 for the Data Dictionary.

CAA-D-84-5

PMM-16 (ff page 2-62)

2.4.xx Program Description

a. Identification

Tape processor - WRBLPA

b. Functions. This subroutine outputs the A-records collected in the TAEDPA array to Unit #14 and to Unit #18.

c. Input

Common blocks

d. Processing. The processing of WRBLP is described as follows:

Call DSYPN2('NEXT') to write the first A-record to display.  
Output all the A-records to Unit #14, the disk file interface.  
AREC is the counter for the number of records in the array.

e. Output. Unit #14.

f. Interfaces

Called by: PIKNON

Calls to: DSYPN2

g. Arguments

h. Tables and Items. Please refer to Table 2-2 for the Data Dictionary.

PMM-17 (ff page 2-66)

2.4.xx Program Description

a. Identification

Tape processor - WRNONA

b. Functions. This subroutine performs the following functions subsequent to the match of UIC input in the User Request File with a UIC on a TAEDPA record. It compares the E-DATE with the fiscal year of the TAEDP record. It generates or deletes A-records on the basis of the relationship. It blanks/zeros MACOM, DAMPL, BRANCH, and SRC and adds a new field in position 174 of the TAEDP record. It outputs the A-record array to Unit #13.

c. Input

Common blocks

d. Processing. The processing of WRNONA is described as follows:

Call DSYNPI to write the first A-record to Unit #17  
If RDATE(NPU) is less than the TAEDPA(1) FY, generate A-records from RDATE(NPU) to TAEDPA(1) FY  
If RDATE(NPU) is greater than TAEDPA(1) FY, delete A-records prior to TAEDPA(1) FY  
If RDATE(NPU) equals the TAEDPA(1) FY, leave the array as is  
Overlay MACOM, DAMPL, UNIT, BRANCH, SRC, and put 'Z' in a new field  
Write the A-records to Unit #13

e. Output

Unit #13, scratch file to store the records for one unit  
Unit #17, alternate print file for nonprogramed unit display

f. Interfaces

Called by: PIKNON

Calls to: None

g. Arguments

h. Tables and Items. Please refer to Table 2-2 for the Data Dictionary.

2.4.xx Program Description

a. Identification

Tape processor - WSRCD

b. Functions. This subroutine rewinds the scratch file, Unit #13, to which records for one unit selected as nonprogramed, have been written. It proliferates the nonunit records according to user request. It overlays all unit records with the new identification in positions 1-6. It outputs all the records for as many units as have been requested to Unit #14 for further processing. It outputs the first A-record of each newly generated unit to Unit #17, the alternate print file, for display.

c. Input

Common blocks - XNONUNT, XRC136

d. Processing. The processing of WRNONA is described as follows: the new identification for the unit is composed of four alpha characters in the array RCODE(2,99), created when the User Request File for Nonunits was read in. A second array, IQY(99), specifies the number of new units requested. Two integer digits are right-justified in positions 5-6 of the new identification. They are in sequence from 01 to the quantity specified. The variable, NPU, received its value in TSTNON when the match was made and is the subscript for user-request arrays. Note that the pointer is repositioned to the beginning of the file prior to each overlay of new identification and subsequent unit output.

e. Output

f. Interfaces

Called by: PIKNON

Calls to: DSYNP1

g. Arguments

h. Tables and Items. Please refer to Table 2-2 for the Data Dictionary.

PMM-19 (ff page 2-106)

2.5.xx Program Description

a. Identification

File processor - LOADD

b. Functions. This subroutine controls the processing of all the D-records for the Tape Processor output file.

c. Input

Common blocks - XASTDTA, XCONTRL

d. Processing. The processing of WRNONA is described as follows:

- Call decode(5) to extract D-record fields
- If LIN has not changed:
  - Update number of D-records
  - If number of D-records not more than 2:
    - Store LIN Name
    - Set RDCDCPL flat
    - Call ACCUM(3)
    - Set LSTRCD to 'D'
    - Return 1
  - If number of D-records is more than 2:
    - Call WRSKP to write this D-record to Skipped Item File
    - Return 1

e. Output

Calls WRSKP, if needed, to write record to Skipped Items File.

f. Interfaces

Called by: MAIN

Calls to: DECOD, WRSKP, CNTRCD, ACCUM

g. Arguments

\* - Represents a numbered return in the calling routine

h. Tables and Items. Please refer to Table 2-5 for the Data Dictionary.

CAA-D-84-5

PMM-20 (ff page 2-109)

2.5.xx Program Description

a. Identification

File processor - RDCNTS

b. Functions. This subroutine reads the ID and record type counts for each unit processed, for use in the generation of summary displays.

c. Input

Common block - XSUMRCD

d. Processing. RDCNTS simply reads a record from a mass store file.

e. Output. None

f. Interfaces

Called by: DSYM2

Calls to: None

g. Arguments. None

h. Tables and Items. Please refer to Table 2-5 for the Data Dictionary.

PMM-21 (ff page 2-113)

2.5.xx Program Description

a. Identification

File processor - WRCLS

b. Functions. This subroutine writes the page classification as a footing centered on the last line of every page.

c. Input

Common blocks - XCONTRL, XDSYWTH

d. Processing. The subroutine WRCLS simply checks the width of the detail line for the report number passed to the routine and prints the run classification, normally CONFIDENTIAL, centered on the final line of the page.

e. Output. The final line of every report.

f. Interfaces

Called by: DSYSM1  
          DSYSM2

Calls to: None

g. Arguments

- DSYNR -the report number (a value of 1 or 2)

h. Tables and Items. Please refer to Table 2-5 for the Data Dictionary.

CAA-D-84-5

PMM-22 (ff page 2-113)

2.5.xx Program Description

a. Identification

File processor - WRCNTS

b. Functions. This subroutine stores the ID and record type counts for each unit processed, for use in the generation of summary displays.

c. Input

Common blocks - XSUMRCD, XUNTDTA

d. Processing

● FILEID writes unit ID and record type counts to mass storage

e. Output. Single record to Unit #3.

f. Interfaces

Called by: LOADBO

Calls to: None

g. Tables and Items. Please refer to Table 2-5 for the Data Dictionary.

## PMM-23 (page 2-130, ff line 19)

CN	DSYCT"(P,0)* DSYSM\$(P,0)* FILEBC(P,0)*	(5x7)	I	The counts at each rating for nonpacing items for each fiscal year
CP	RDRTG(I)* DSYCT1(I,0)* DSYSM4(P,0) FILEBS(P,0)*	(5x7)	I	The counts at each rating for pacing items for each fiscal year

## PMM-24 (page 2-130, ff line 27)

CT	RDRTG(I)* DSYCT2(I,0) DSYSM4(P,0)	(5x7)	I	The counts at each rating for all times for each fiscal year
----	---	-------	---	--

CAA-D-84-5

PMM-25 (ff page 2-157)

#### 2.6.4 Program Description

##### a. Identification

Assessment processor - BLDRTG

b. Functions. This subroutine builds a mass storage file of unit rating data (overall data and marginal counts) from the unit rating data in individual FY files. In this process, zero entries inserted for FY in which no rating data is present to generate a uniform array of rating data by FY for each unit present.

##### c. Input

Common block - XRSULTS

##### d. Processing. The processing of BLDRTG is described as follows:

- Establish a POOLNR index
- Scan across each FY file for match on index
- Where match not found, insert a blank record
- Write summary of data from each FY file to an output file
- Continue until POOLNR index matches total number of units present (NUIC)
- If an FY file EOF occurs before NUIC is reached, enter blank record for FY file and continue

e. Output. Write of individual FY file records as a composite record to Unit #30.

##### f. Interfaces

Called by: MAIN

Calls to: FSORT

##### g. Arguments

h. Tables and Items. Please refer to Table 2-6 for the Data Dictionary.

PMM-26 (ff page 2-157)

### 2.6.5 Program Description

#### a. Identification

Assessment processor - BLDTRL

b. Functions. This subroutine builds a file of trial case rating values for use in display generation. The original data file is sorted and padded out with any missing fiscal years of data and written as a mass storage for access during subsequent display generation.

#### c. Input

Common blocks - XRSULTS, XUNTDATA

#### d. Processing. The processing of BLDTRL is described as follows:

- Rewind file of rating data
- Sort file into POOLNR-FY order
- Rewind sorted file and examine for null rating fields and FY not present
- Pad out with blank records as needed and write out rating results to Unit #18

#### e. Output. Write of sorted rating file to Unit #18.

#### f. Interfaces

Called by: MAIN

Calls to: FSORT

#### g. Arguments. None

h. Tables and Items. Please refer to Table 2-6 for the Data Dictionary.

2.6.17 Program Description

a. Identification

Assessment processor - DSYTRL

b. Functions. This subroutine displays counts and marginal totals of the number of units selected by the user for participation in the equipment redistribution based upon both worksheet and parameter specification.

c. Input

Common blocks - XSELECT, XCONTRL

d. Processing. The processing of DSYTRL is described as follows:

- Call to DSYCTL to print header
- Summation of row and column and grand total of counts, computed separately for worksheet and parameter selected units
- Display of row, column, and grand total values

e. Output. Display #13.

f. Interfaces

Called by: MAIN

Calls to: DSYCTL  
WRCLS

g. Arguments. None

h. Tables and Items. Please refer to Table 2-6 for the Data Dictionary.

PMM-28 (ff page 2-190)

2-6.31 Program Description

a. Identification

Assessment processor - RDRTG

b. Functions. This subroutine reads the units' rating and margin counts stored by BLDRTG for display purposes.

c. Input

- File #30 (temporary)

d. Processing. The processing of RDRTG is described as follows:

- RDRTG reads a single record on File #30

e. Output. Common block XRESULTS.

f. Interfaces

Called by: DSYCT1  
DSYCT2  
DSYCT3  
DSYSM3  
DSYSM4  
DSYWS  
FILEWS  
FRQCNT

Calls to: None

g. Arguments

h. Tables and Items. Please refer to Table 2-6 for the Data Dictionary.

2.6.36 Program Description

a. Identification

Assessment processor - TSTBUF

b. Functions. This subroutine tests LIN and LIN substitutes stored in buffer with LIN and LIN substitutes from a billpayer unit to determine if a transfer of assets can be made. The transfer is controlled by the number of substitute LIN associated with billpayer LIN.

c. Input

Common blocks - XITMDTA, XBUFR

d. Processing. The processing of TSTBUF is described as follows:

- Set up local variable for number of billpayer substitutes present (max = 2)
- Transfer to test for match based on number of billpayer substitute LIN present
- If match present, return to continue processing of LIN; if no match, return to process next LIN

e. Output. Numbered return to calling program unit.

f. Interfaces

Called by: BALBUF

Calls to: None

g. Arguments

IFY - Index to FY under consideration  
IP - Pointer to matched LIN in buffer  
I - Alternate return if no LIN match made

h. Tables and Items. Please refer to Table 2-6 for the Data Dictionary.

PMM-30 (ff page 2-206)

2.6.43 Program Description

a. Identification

Assessment processor - WRRTG

b. Functions. This subroutine saves the unit rating data (rating and margin counts) for subsequent display.

c. Input

Common blocks - XCONTRL, XRSULTS XUNTDATA, XRTGCTL

d. Processing. The processing of WRRTG is described as follows:

- For single rated units, writes ratings and margin counts to currently defined FY file
- For dual-rated units, computes differences (before and after unit TOE changes) in rating and margin counts and writes values to currently defined FY file

e. Output. Write to Unit #(20+IFY).

f. Interfaces

Called by: URATE

Calls to: None

g. Arguments. None.

h. Tables and Items. Please refer to Table 2-6 for the Data Dictionary.

CAA-D-84-5

PMM-31 (page 3-2, ff line 33)

- User data

The user provides two files of data associated with the generation of unprogramed units. One file identifies the existing units which are to be the prototypes for the unprogramed units. The other file identifies those existing units which are to provide the assets (billpayer units) to fill the newly created units.

PMM-32 (page 3-1, ff line 29)

- Unprogramed Unit File

This file is the third of three major outputs from the Tape Processor and contains data on the unprogramed units and the billpayer units.

PMM-33 (page 3-6, ff line 30)

The D-record is identical to the C-record except for the following item:

- SUB-LIN (substitute LIN) appears in columns 69-76

PMM-34 (page 3-7, line 22)

#### UNPROGRAMED UNIT FILE

Record Length: 239 characters

Storage Medium: mass storage used: Tape, file

#### Processors

This file exists in the identical format to the TAEDP data except for a "3" in position 15 to indicate that the units were selected for unprogramed unit creation.

**5-3. NEW LINWORK.** New linework has been prepared to either replace existing linework or to be included as additional linework in the documentation. The linework is contained in appendices, with a separate appendix for each processor as follows:

Appendix F - Tape Processor

Appendix G - File Processor

Appendix H - Assessment Processor

Current page	Action
2-10	Replace with F-3
2-12	Follow with F-5
2-13	Replace with F-7
2-15	Replace with F-9
2-16	Replace with F-11
2-28	Follow with F-13
2-28	Follow with F-15
2-74	Replace with G-3
2-75	Replace with G-5
2-76	Replace with G-7
2-78	Replace with G-9
2-79	Replace with G-11
2-125	Replace with H-3
2-127	Replace with H-5
2-128	Replace with H-7
2-150	Follow with H-9

**APPENDIX A**  
**DOCUMENTATION CONTRIBUTORS**

**1. STUDY TEAM**

Mr. James J. Connelly, Study Director, Force Systems Directorate  
Ms. Merle V. Lehmann, Modeling Directorate

**2. DOCUMENT REVIEW**

Mr. Kumud Mathur, Force Systems Directorate  
Mr. Howard Whitehead, Force Systems Directorate

**APPENDIX B**  
**REFERENCES**

**DEPARTMENT OF THE ARMY**

**US Army Concepts Analysis Agency**

1. Management of MTOE Effective Dates Based on Equipment Availability (MTO Dates), CAA-SR-83-3, July 1983
2. Effective Date (E-DATE) Model Documentation, Volume I - Functional Description, CAA-D-83-3, October 1983
3. Effective Date (E-DATE) Model Documentation, Volume II - User's Manual, CAA-D-83-3, October 1983
4. Effective Date (E-DATE) Model Documentation, Volume III - Computer Operation Manual, CAA-D-83-3, October 1983
5. Effective Date (E-DATE) Model Documentation, Volume IV - Program Maintenance Manual, CAA-D-83-3, October 1983
6. Effective Date (E-DATE) Model Documentation, Supplement, CAA-D-84-6, May 1984

**APPENDIX C**  
**NEW LINWORK**  
**FUNCTIONAL DESCRIPTION**

CAA-D-84-5

(NOT USED)

C-2

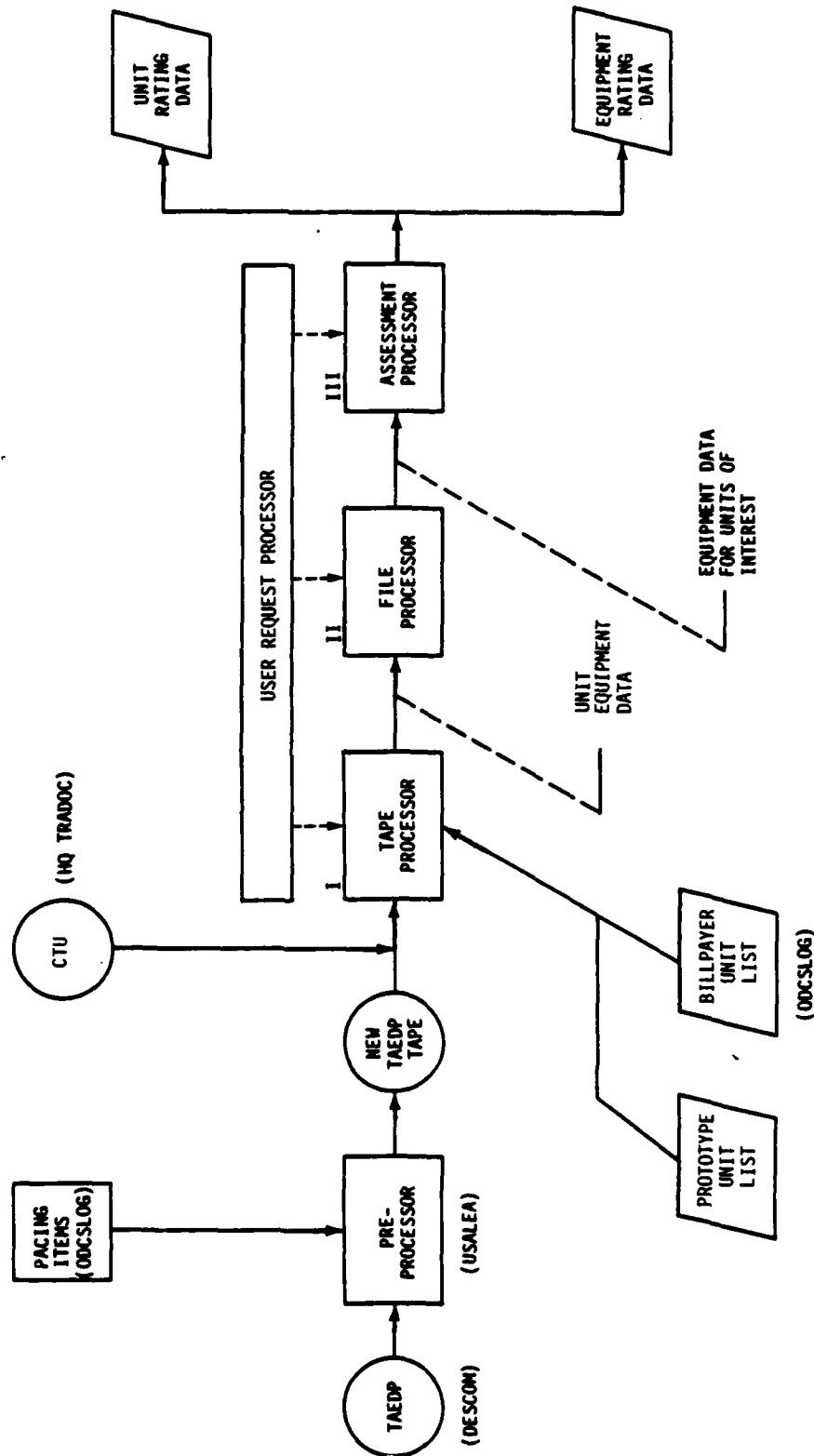

Figure 2-1. System Organization

CAA-D-84-5

(NOT USED)

C-4

EDATE MODEL  
DISPLAY AP /13/

UNIT EQUIPMENT READINESS  
REDISTRIBUTION UNITS

PAGE 1  
DATA DATE: TESTDATA  
REPT DATE: 09/01/84

DATA SET: ACTIVATED UNITS  
RUN TYPE: TRIAL CASE

\*\*\*\*\* UNCLASSIFIED \*\*\*\*\*

NUMBER OF UNITS SELECTED

	FY	UPRATED UNITS	DOWNRATED UNITS	TOTALS
WORKSHEET	83	0	0	0
PARAMETER	83	4	4	8
TOTALS	83	4	4	8
WORKSHEET	84	0	0	0
PARAMETER	84	4	4	8
TOTALS	84	4	4	8
WORKSHEET	85	0	0	0
PARAMETER	85	4	4	8
TOTALS	85	4	4	8
WORKSHEET	86	0	0	0
PARAMETER	86	4	4	8
TOTALS	86	4	4	8
WORKSHEET	87	0	0	0
PARAMETER	87	3	4	7
TOTALS	87	3	4	7
WORKSHEET	88	0	0	0
PARAMETER	88	3	4	7
TOTALS	88	3	4	7
WORKSHEET	89	0	0	0
PARAMETER	89	3	4	7
TOTALS	89	3	4	7

Figure 3-11. Redistribution Units

**APPENDIX D**  
**NEW LINWORK**  
**USER MANUAL**

CAA-D-84-5

(NOT USED)

D-2

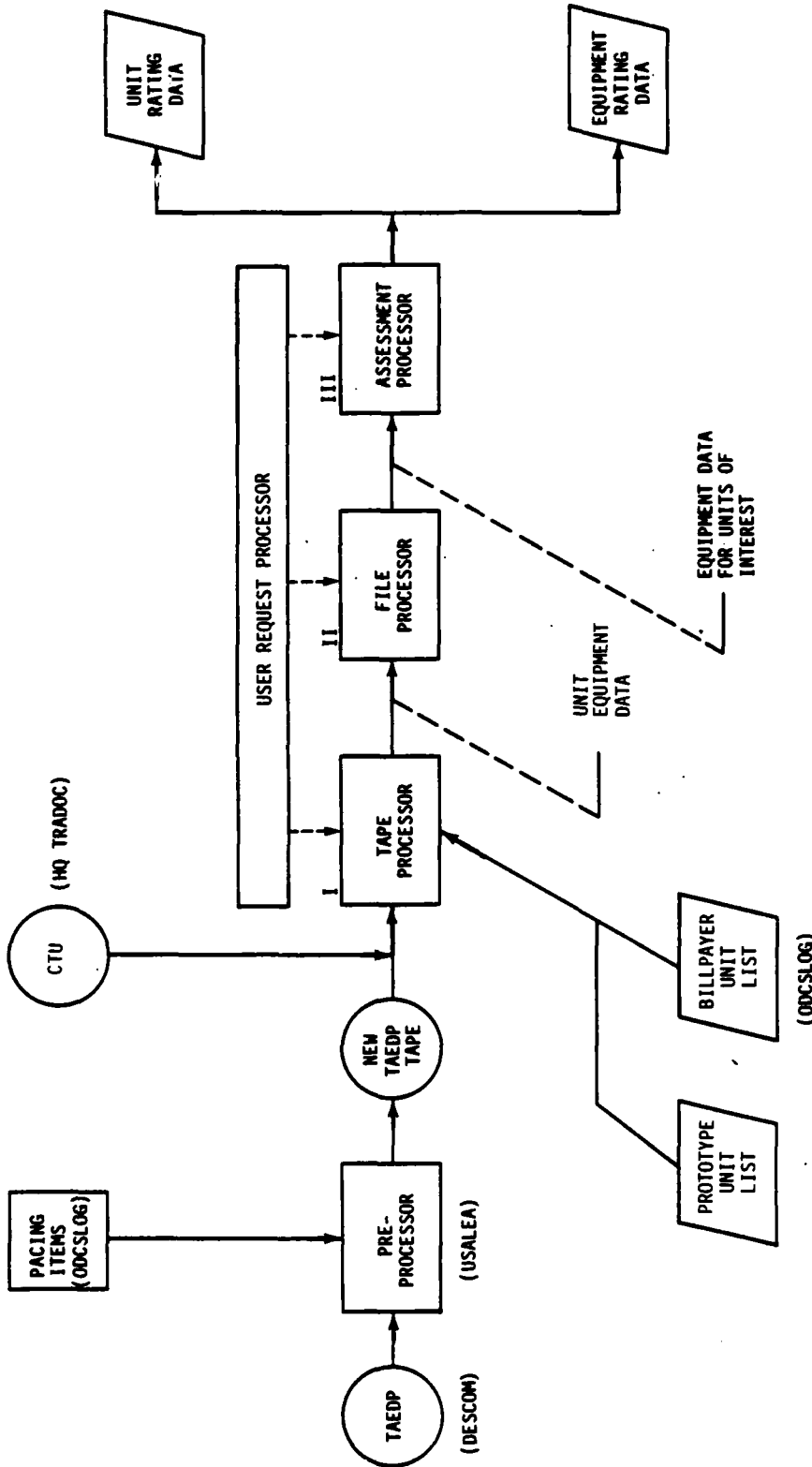

Figure 2-1. System Flow

CAA-D-84-5

(NOT USED)

D-4

EDATE MODEL  
DISPLAY AP /13/

UNIT EQUIPMENT READINESS  
REDISTRIBUTION UNITS

PAGE 1  
DATA DATE: TESTDATA  
REPT DATE: 09/01/84

DATA SET: ACTIVATED UNITS  
RUN TYPE: TRIAL CASE

\*\*\*\*\* UNCLASSIFIED \*\*\*\*\*

NUMBER OF UNITS SELECTED

	FY	UPRATED UNITS	DOWNRATED UNITS	TOTALS
WORKSHEET	83	0	0	0
PARAMETER	83	4	4	8
TOTALS	83	4	4	8
WORKSHEET	84	0	0	0
PARAMETER	84	4	4	8
TOTALS	84	4	4	8
WORKSHEET	85	0	0	0
PARAMETER	85	4	4	8
TOTALS	85	4	4	8
WORKSHEET	86	0	0	0
PARAMETER	86	4	4	8
TOTALS	86	4	4	8
WORKSHEET	87	0	0	0
PARAMETER	87	3	4	7
TOTALS	87	3	4	7
WORKSHEET	88	0	0	0
PARAMETER	88	3	4	7
TOTALS	88	3	4	7
WORKSHEET	89	0	0	0
PARAMETER	89	3	4	7
TOTALS	89	3	4	7

Figure 3-11. Redistribution Units

**APPENDIX E**

**NEW LINWORK**

**COMPUTER OPERATION MANUAL**

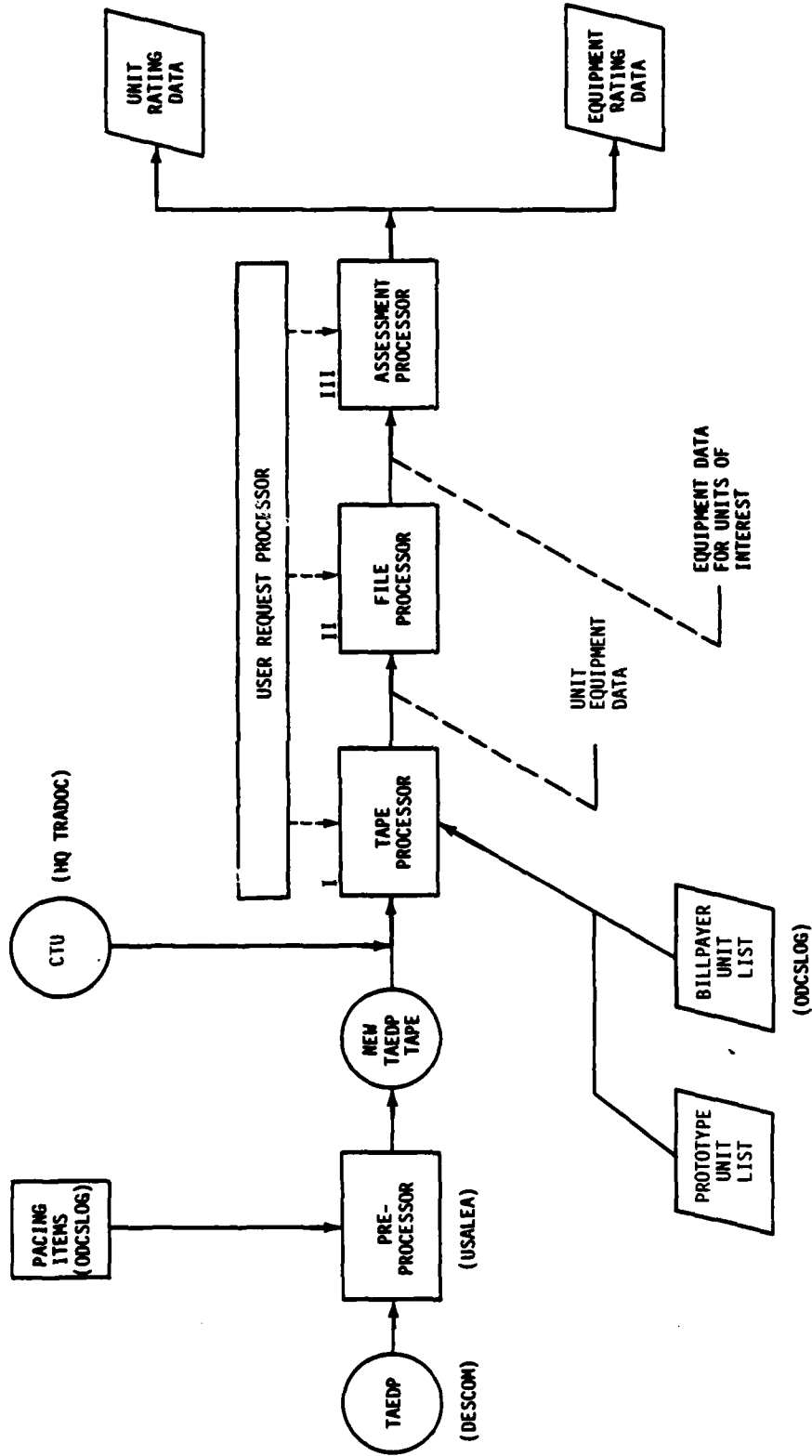

Figure 2-1. System Flow

**APPENDIX F**  
**NEW LINWORK**  
**PROGRAM MAINTENANCE MANUAL**  
**TAPE PROCESSOR**

CAA-D-84-5

(NOT USED)

F-2

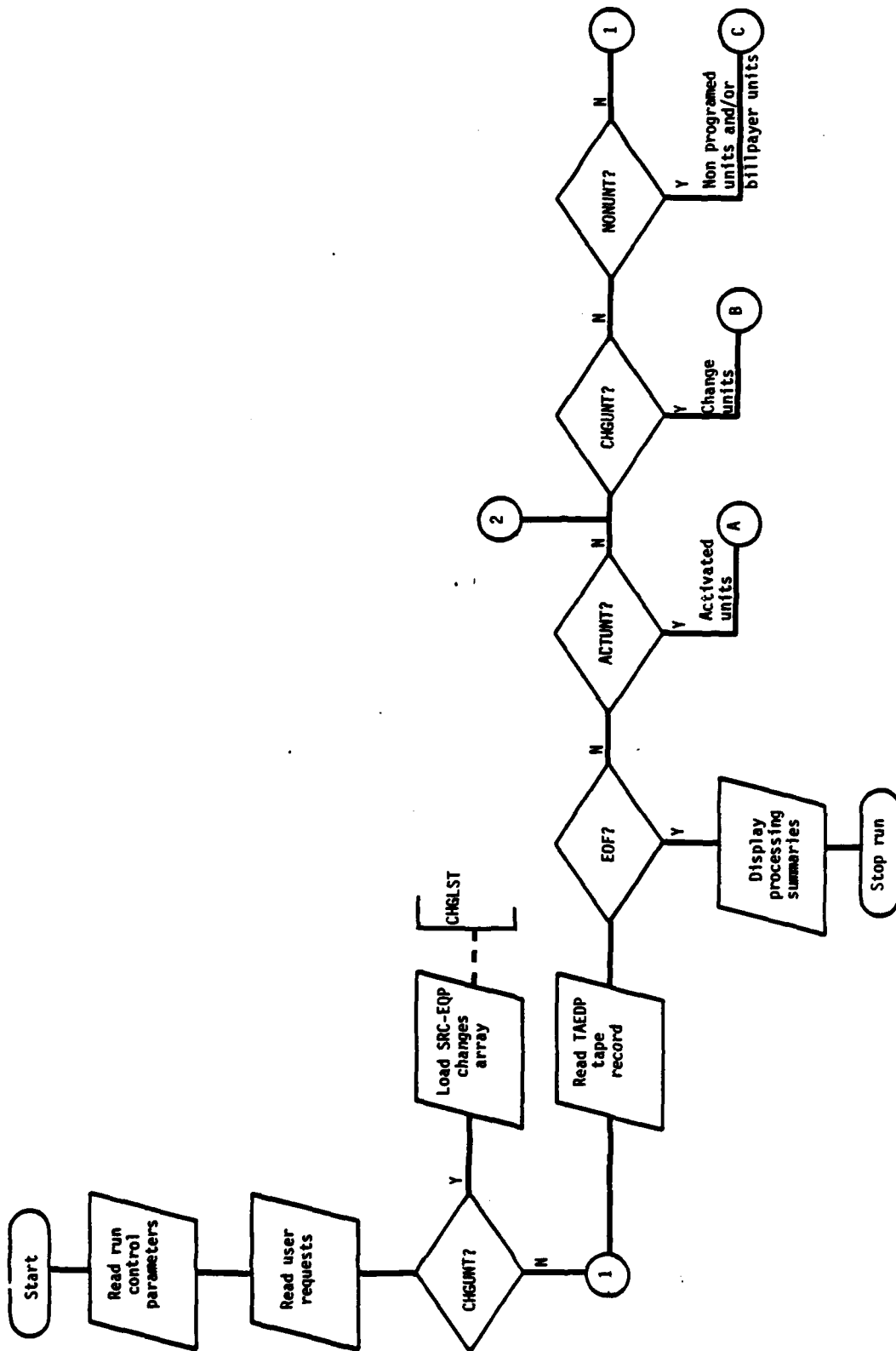

Figure 2-2. Tape Processor Flow Diagram (page 1 of 4 pages)

CAA-D-84-5

(NOT USED)

F-4

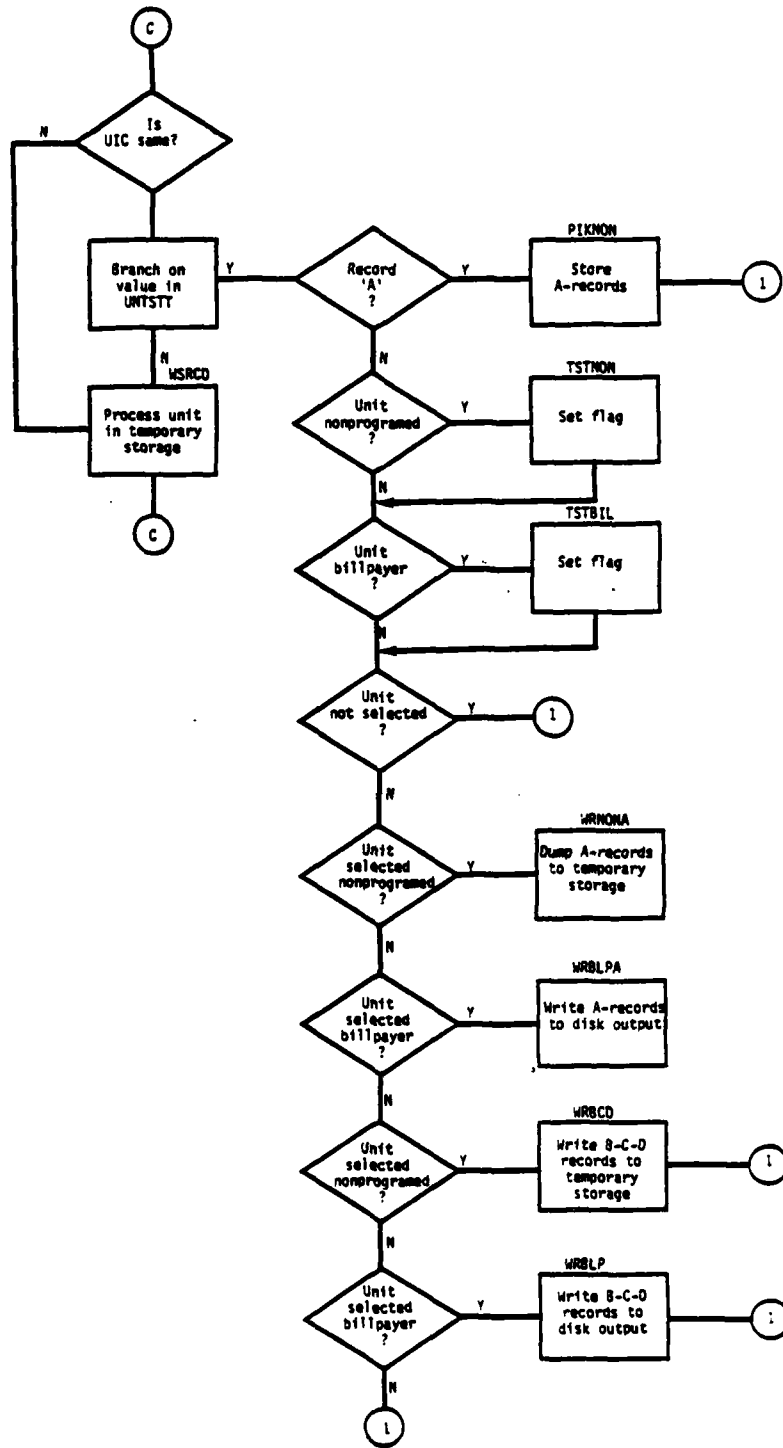

Figure 2-2. Tape Processor Flow Diagram (page 4 of 4 pages)

CAA-D-84-5

(NOT USED)

F-6

		COMMON BLOCK										
		ICONTL	XINPUT	RECD	ISECMT	ISECDA	ISECBV	ISECTP	ISUMXL	ISYWTB	INONHT	ISYTYT
ROUTINE	AMTSEC											
	CHCLST											
	CHREQP											
	CHLST											
	CHKSPC											
	CHKSRC											
	CNTLVL											
	CNTUPY											
	DECODE											
	DSTALL											
	DSTCTL											
	DSTCT1											
	DSTCT2											
	DSTPY1											
	DSTPY2											
	DSTNPI											
	DSTNPS											
	ENCOD											
	MAIN-CHG											
	MAIN-MON											
	MAIN-MLT											
	PAGADV											
	PIRACT											
	PIRCHG											
	PIRCOM											
	PIRNON											
	PIRSPC											
	RDRCD											
	RDRCD-TAPE											
	RDRQST											
	RDRPC											
	TSTBIL											
	TSTNON											
	VRBCD											
	VRBLP											
	VRBLPA											
	VRCTT											
	VRCLS											
	VRHDC											
	VRMSG											
VRNONA												
VRPCD												
VRTTL												
VRPCD												
XLATE												

Figure 2-3. Common Block Cross-References (Tape Processor)

CAA-D-84-5

(NOT USED)

F-8



CAA-D-84-5

(NOT USED)

F-10



CAA-D-84-5

(NOT USED)

F-11

EDATE MODEL  
DISPLAY Tp / 7/

TAPE PROCESSOR RUN  
NON UNIT SUMMARY

DATA DATE: TESTDATA  
REPT DATE: 04/18/84

\*\*\*\*\* UNCLASSIFIED \*\*\*\*\*

NON-PROGRAMED UNITS AS REQUESTED BY USER

PROTO UIC	NEW UIC	EDATE	DAMPL	CLAIMANT
UNT002	TU0201	83	3774	CO NBC DEF1+J
UNT002	TU0202	83	3774	CO NBC DEF1+J
UNT005'	TU0501	83	3778	BN VULCAN TOWED (-)
UNT008	TU0801	83	102	BN AIR ASSAULT
UNT008	TU0802	83	102	BN AIR ASSAULT
UNT008	TU0803	83	102	BN AIR ASSAULT

Figure 2-12. Report #6, New Unit Summary

CAA-D-84-5

(NOT USED)

F-14

DISPLAY TP / 8/		BILLPAYER SUMMARY			DATA DATE: TESTDATA REPT DATE: 04/18/84	
***** UNCLASSIFIED *****						
BILLPAYER UNITS TO FILL USER REQUEST						
UIC	TYPE	NOENCLATURE	MACOM	BR	DAMPL-RANGE	SRC
UNTO02	UIC	UNTO02	NG	CM	3774-10000	03387J200
UNTO03	SRC	05147J200	NG	EN	3774-10000	05147J200
UNTO06	UIC	UNTO06	NG	AD	2153-10000	44667J200
UNTO08	SRC	07055J000	EUR	IN	102-10000	07055J000
UNTO10	TOE	37J100	EUR	AD	2700-10000	44637J100
UNTO11	UIC	UNTO11	EUR	IN	1672-10000	07245J110
UNTO12	TOE	45J110	FC	IN	1672-10000	07245J110

Figure 2-13. Report #7, Billpayer Summary

**APPENDIX G**  
**NEW LINEWORK**  
**PROGRAM MAINTENANCE MANUAL**  
**FILE PROCESSOR**

CAA-D-84-5

(NOT USED)

G-2

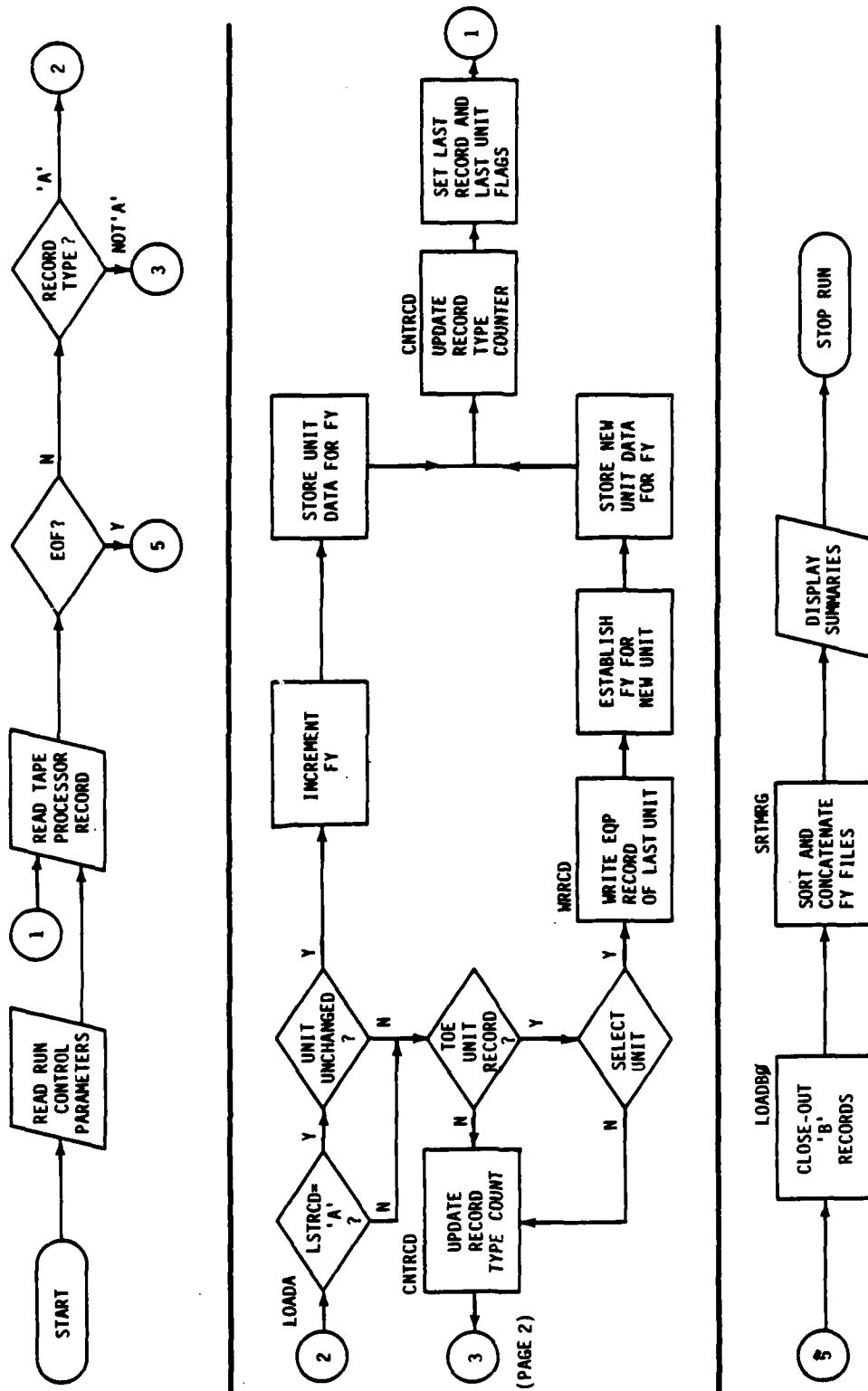

Figure 2-12. File Processor Flow Diagram (page 1 of 2 pages)

CAA-D-84-5

(NOT USED)

G-4

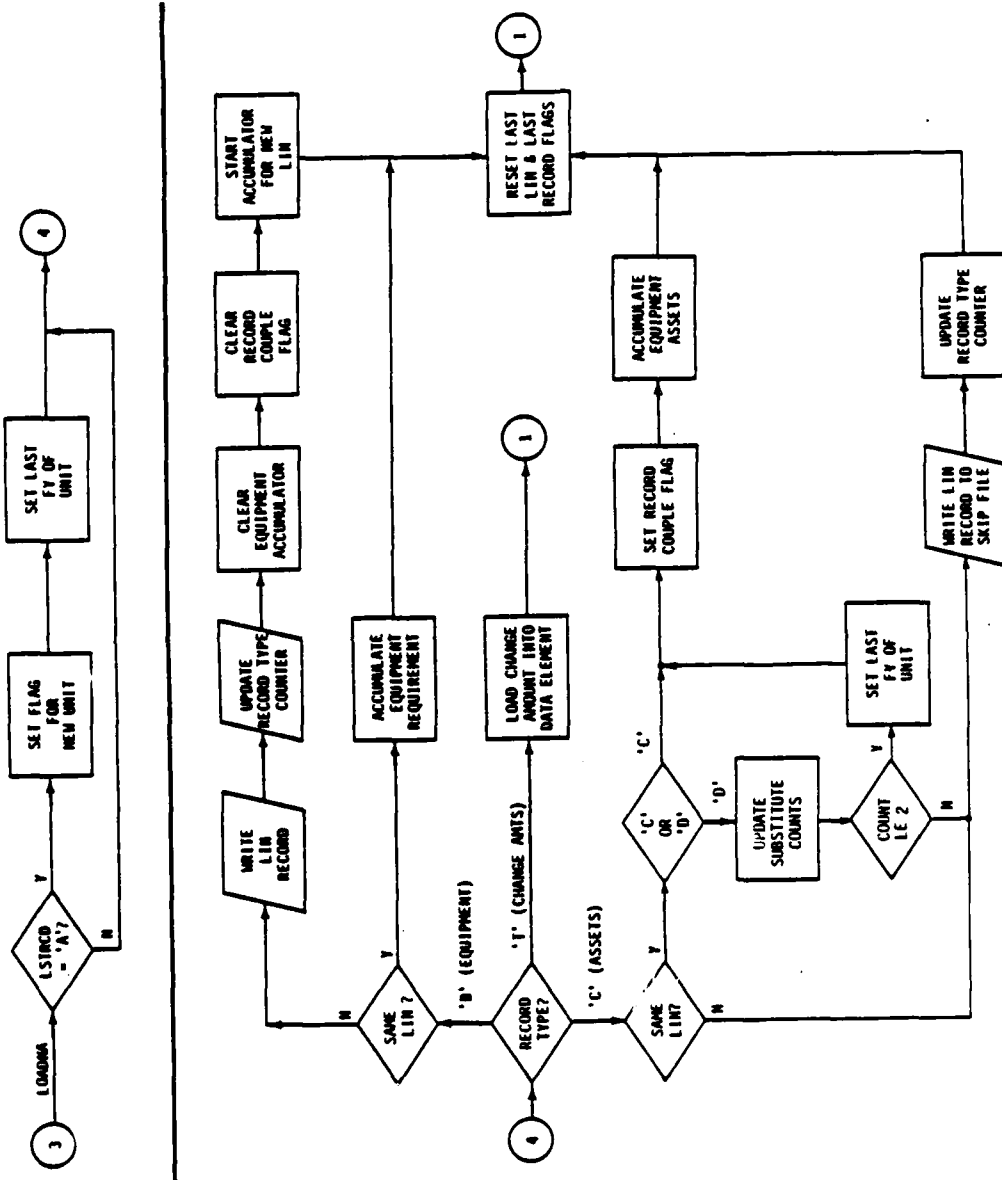

Figure 2-12. File Processor Flow Diagram (page 2 of 2 pages)

CAA-D-84-5

(NOT USED)

G-6

		COMMON BLOCK									
		YASTDTA	XCONTRL	XINPUT	XRC	XRQMDTA	XSUMDL	XSUMRCD	XUNDTA	XDSYWTH	XDSYTXT
ROUTINE	ACCUM	■				■					
	CNTLVL		■				■	■	■		
	CNTRCD		■					■			
	DECOD	■			■	■			■		
	DSYCTL										
	DSYSM1						■				
	DSYSM2						■	■			
	LOADA		■	■					■		
	LOADB		■	■			■		■		
	LOADBO		■	■					■		
	LOADC		■	■							
	LOADD		■	■							
	LOADNA		■	■					■		
	LOADT										
	MAIN			■	■						■
	PAGADV										
	RDCNTS								■		
	RDRCD			■		■					
	SRTMRG		■	■	■		■		■		
	TSTSET			■	■						
	TSTUNT			■	■						
	WRCLS			■							■
	WRCNTS								■		
	WRHDG			■	■						■
	WRRCD		■	■	■		■		■	■	
	WRSKP		■	■							
	WRTTL			■							■
	XLATE		■	■	■		■				

Figure 2-3. Common Block Cross-References (File Processor)

CAA-D-84-5

(NOT USED)

G-8

AD-R146 050

EFFECTIVE DATE (E-DATE) MODEL DOCUMENTATION CHANGES TO  
REFLECT MODEL ENHANCEMENT(U) ARMY CONCEPTS ANALYSIS  
AGENCY BETHESDA MD J J CONNELLY ET AL. AUG 84  
CAR-D-84-5

2/2

UNCLASSIFIED

F/G 9/2

NL

END

FORMED

DTIC

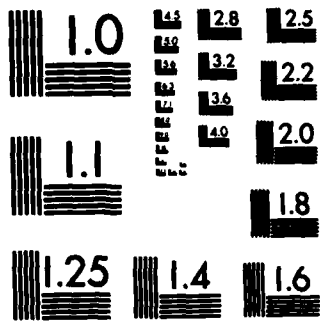

MICROCOPY RESOLUTION TEST CHART

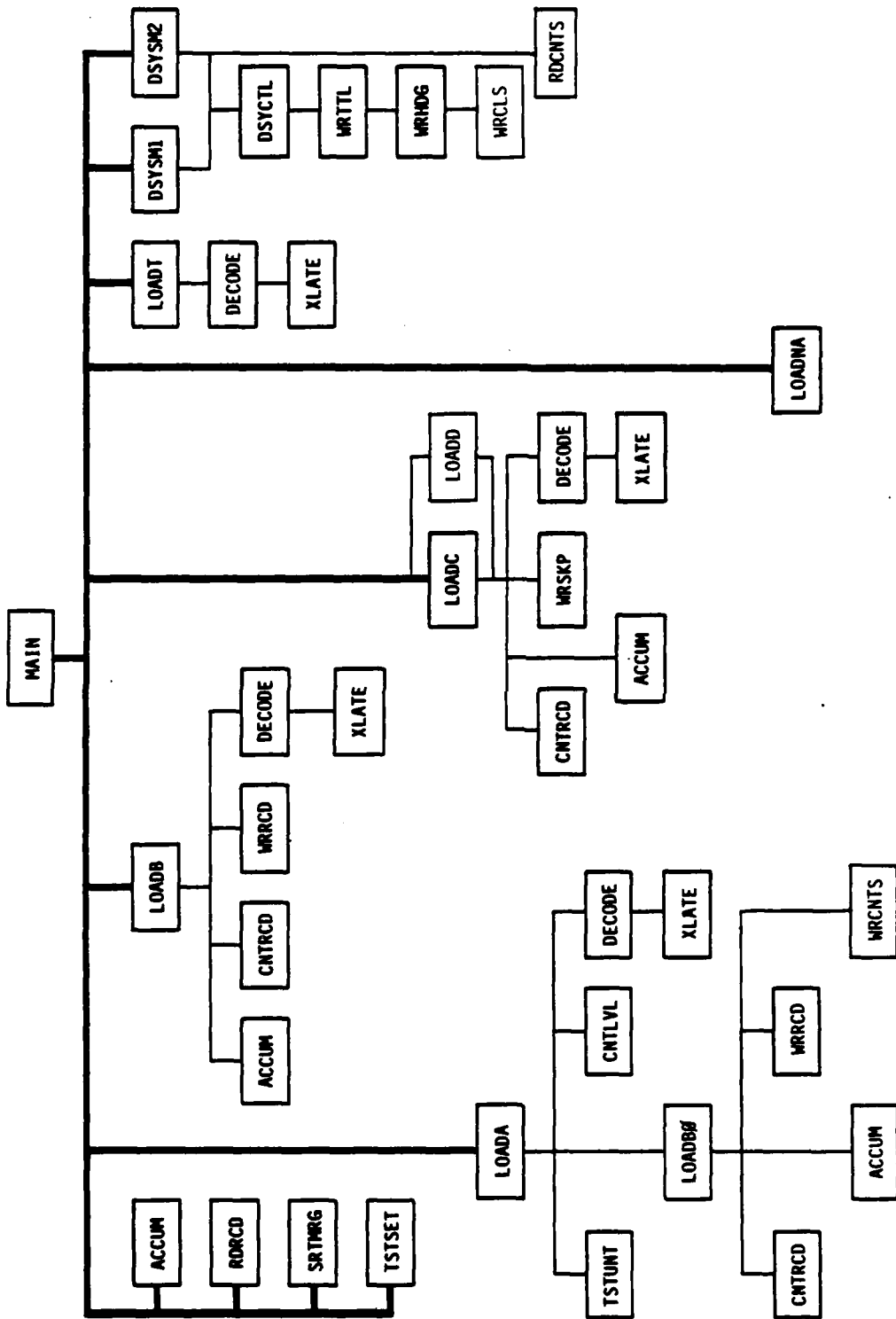

Figure 2-14. Program Unit Hierarchy (File Processor)

CAA-D-84-5

(NOT USED)

G-10

		CALLED ROUTINE																												
		ACCUM	CNTLVL	CNTRCD	DECODE	DSYCTL	DSYSM1	DSYSM2	LOADA	LOADB	LOADB0	LOADC	LOADD	LOADNA	LOADT	MAIN	PAGADV	RDCNTS	RDRCD	SRTMRG	TSTSET	TSTUNT	WRCLS	WRCNTS	WRHDG	WRRCD	WRSKP	WRITL	XLATE	
CALLING ROUTINE	ACCUM																													
	CNTLVL																													
	CNTRCD																													
	DECODE																													
	DSYCTL																													
	DSYSM1																													
	DSYSM2																													
	LOADA																													
	LOADB																													
	LOADB0																													
	LOADC																													
	LOADD																													
	LOADNA																													
	LOADT																													
	MAIN																													
	PAGADV																													
	RDCNTS																													
	RDRCD																													
	SRTMRG																													
	TSTSET																													
	TSTUNT																													
	WRCLS																													
	WRCNTS																													
	WRHDG																													
	WRRCD																													
	WRSKP																													
	WRITL																													
	XLATE																													

Figure 2-5. Subroutine Cross-References (File Processor)

**APPENDIX H**

**NEW LINEWORK**

**PROGRAM MAINTENANCE MANUAL**

**ASSESSMENT PROCESSOR**

CAA-D-84-5

(NOT USED)

H-2

		COMMON BLOCK									
		XBUFR	XCONTRL	XCOUNT	XDSYWTH	XIOFILE	XITMDTA	XRESULTS	XRTGCTL	XSELECT	XUNTDATA
ROUTINE	BALBUF	■									
	BLDADI		■								
	BLDRTG							■			
	BLDTRL										■
	CLRBUF	■						■			
	DSTYBUF	■	■								
	DSTYCTL										
	DSTYCT1		■					■			
	DSTYCT2		■								
	DSTYCT3								■		
	DSTYINP									■	
	DSTYSM1			■							
	DSTYSM2			■							
	DSTYSM3		■					■			
	DSTYSM4		■					■			
	DSTYTRL		■								■
	DSTYWS		■					■			
	DSTYXF1		■					■			■
	DSTYXF2		■					■			■
	FILEBC		■					■			
	FILEWS		■					■			
	FRQCNT			■				■			
	GENBUF		■					■			
	IOCTL		■						■		
	LINTST							■		■	
	MAIN-BAS		■			■			■	■	
	MAIN-TRL		■			■			■	■	
	ORDBUF		■								
	PAGADY										
	PIKUNT										■
	RDRCD		■			■	■				■
	RDRTG								■		
	RDWS										
	SAVID		■				■				■
	TBLQTY										
	TBLRTG										
	TSTBUF		■								
	UICRTG		■					■			
	UICST		■					■	■	■	■
	URATE									■	
WRCLS		■		■							
WRHDG		■	■				■				
WRRCO		■				■				■	
WRRTG		■					■	■	■	■	
WR TTL		■		■							
XERDTA									■		

Figure 2-3. Common Block Cross-References (Assessment Processor)

CAA-D-84-5

(NOT USED)

H-4



CAA-D-84-5

(NOT USED)

H-6



CAA-D-84-5

(NOT USED)

H-8

EDATE MODEL  
 DISPLAY AP /127

UNIT EQUIPMENT READINESS  
 REDISTRIBUTION UNITS

PAGE 1  
 DATA DATE: TESTDATA  
 REPT DATE: 09/01/84

DATA SET: ACTIVATED UNITS  
 RUN TYPE: TRIAL CASE

\*\*\*\*\* UNCLASSIFIED \*\*\*\*\*

NUMBER OF UNITS SELECTED

	FY	UPRATED UNITS	DOWNRATED UNITS	TOTALS
WORKSHEET	83	0	0	0
PARAMETER	83	8	8	8
TOTALS	83	8	8	8
WORKSHEET	84	0	0	0
PARAMETER	84	8	8	8
TOTALS	84	8	8	8
WORKSHEET	85	0	0	0
PARAMETER	85	8	8	8
TOTALS	85	8	8	8
WORKSHEET	86	0	0	0
PARAMETER	86	8	8	8
TOTALS	86	8	8	8
WORKSHEET	87	0	0	0
PARAMETER	87	7	4	7
TOTALS	87	7	4	7
WORKSHEET	88	0	0	0
PARAMETER	88	7	4	7
TOTALS	88	7	4	7
WORKSHEET	89	0	0	0
PARAMETER	89	7	4	7
TOTALS	89	7	4	7

Figure 2-34. Report #13, Redistribution Units

**APPENDIX I  
DISTRIBUTION**

Addressee	No of copies
Deputy Chief of Staff for Logistics Headquarters, Department of the Army ATTN: DALO-PLF Washington, DC 20310	5
Commander US Army Logistics Evaluation Agency ATTN: DALO-LED New Cumberland Army Depot New Cumberland, PA 17070	5
Director Defense Logistics Studies Information Exchange US Army Logistics Management Center Fort Lee, VA 23801	1
Defense Technical Information Center ATTN: DTIC-DDA Cameron Station Alexandria, VA 22314	2
The Pentagon Library (Army Studies Section) ATTN: ANRAL-RS The Pentagon Washington, DC 20310	1

**END**

**FILMED**

**10-84**

**DTIC**