

AD-A146 227

ELECTRONIC MOVING MAP DEVELOPMENT PROGRAM(U) LEAR
SIEGLER INC GRAND RAPIDS MI INSTRUMENT DIV D DENEYER
DEC 82 MISC-1970 AFWAL-TR-82-3101 F33615-80-C-3625
F/G 8/2

1/1

UNCLASSIFIED

NL

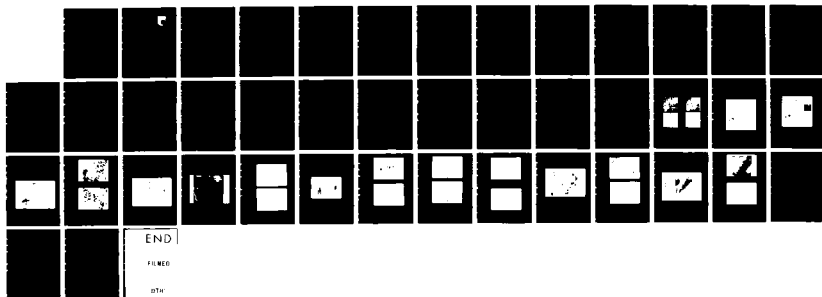

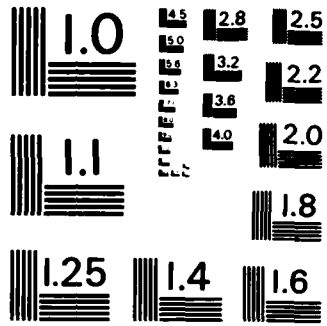

MICROCOPY RESOLUTION TEST CHART
NATIONAL BUREAU OF STANDARDS-1963-A

AFWAL-TR-82-3101

ELECTRONIC MOVING MAP DEVELOPMENT PROGRAM

Instrument Division
Lear Siegler, Inc.
4141 Eastern Ave., S. E.
Grand Rapids, MI 49508



DECEMBER 1982

Final Report for Period August 1980 - March 1982

Approved for public release; distribution unlimited

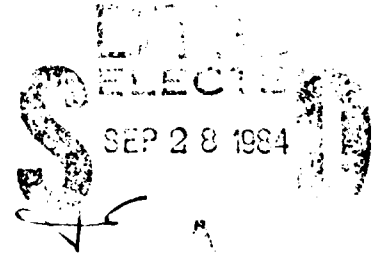

AD-A146 227

DTIC FILE COPY

FLIGHT DYNAMICS LABORATORY
AIR FORCE WRIGHT AERONAUTICAL LABORATORIES
AIR FORCE SYSTEMS COMMAND
WRIGHT-PATTERSON AIR FORCE BASE, OHIO 45433

*Original contains color
plates. All DTIC reproductions
will be in black and
white.

84 09 25 068

NOTICE

When Government drawings, specifications, or other data are used for any purpose other than in connection with a definitely related Government procurement operation, the United States Government thereby incurs no responsibility nor any obligation whatsoever; and the fact that the government may have formulated, furnished, or in any way supplied the said drawings, specifications, or other data, is not to be regarded by implication or otherwise as in any manner licensing the holder or any other person or corporation, or conveying any rights or permission to manufacture use, or sell any patented inventio. that may in any way be related thereto.

This report has been reviewed by the Office of Public Affairs (ASD/PA) and is releasable to the National Technical Information Service (NTIS). At NTIS, it will be available to the general public, including foreign nations.

This technical report has been reviewed and is approved for publication.

William L. Augustine

William L. Augustine
Electronic Engineer

Charles R. Goss, Jr.

CHARLES R. GOSS, JR, LT COL, USAF
Crew Systems Development Branch

FOR THE COMMANDER

H. Max Davis

H. MAX DAVIS
Assistant Chief
Flight Control Division

"If your address has changed, if you wish to be removed from our mailing list, or if the addressee is no longer employed by your organization please notify AFWAL W-PAFB, OH 45433 to help us maintain a current mailing list".

Copies of this report should not be returned unless return is required by security considerations, contractual obligations, or notice on a specific document.

UNCLASSIFIED

SECURITY CLASSIFICATION OF THIS PAGE (When Data Entered)

REPORT DOCUMENTATION PAGE		READ INSTRUCTIONS BEFORE COMPLETING FORM
1. REPORT NUMBER AFWAL-TR-82-3101	2. GOVT ACCESSION NO.	3. RECIPIENT'S CATALOG NUMBER
4. TITLE (and Subtitle) ELECTRONIC MOVING MAP DEVELOPEMENT PROGRAM		5. TYPE OF REPORT & PERIOD COVERED FINAL - R & D Aug. 1980 to Mar. 1982
		6. PERFORMING ORG. REPORT NUMBER MISC-1970
7. AUTHOR(s) Donald DeMeyer		8. CONTRACT OR GRANT NUMBER(s) F33615-80-C-3625
9. PERFORMING ORGANIZATION NAME AND ADDRESS LEAR SIEGLER, INC. 4141 EASTERN AVE. S.E. GRAND RAPIDS, MICH. 49508		10. PROGRAM ELEMENT, PROJECT, TASK AREA & WORK UNIT NUMBERS 6201F-24030449
11. CONTROLLING OFFICE NAME AND ADDRESS Flight Dynamics Laboratory AFWAL/FIGR, AF Wright Aeronautical Laboratories, Wright- Patterson AFB, OH 45433		12. REPORT DATE September 14, 1982
		13. NUMBER OF PAGES 39
14. MONITORING AGENCY NAME & ADDRESS (if different from Controlling Office)		15. SECURITY CLASS. (of this report) UNCLASSIFIED
		15a. DECLASSIFICATION/DOWNGRADING SCHEDULE
16. DISTRIBUTION STATEMENT (of this Report) Approved for public release; distribution unlimited		
17. DISTRIBUTION STATEMENT (of the abstract entered in Block 20, if different from Report)		
18. SUPPLEMENTARY NOTES		
19. KEY WORDS (Continue on reverse side if necessary and identify by block number) Electronic Map Display, Digital Map Display, Moving Map Display, Digital Graph ics Processor, Map Data Evaluation, Map Data Digitization, Raster Graphics, Vector Graphics, Map Processor Speed Requirements, Graphics System Comparison, Pictorial Representation of Map Information, CRT Display of Maps, Matrix Display of Maps. Other Graphics Presentation.		
20. ABSTRACT (Continue on reverse side if necessary and identify by block number) The Air Force Flight Dynamics Laboratory has sponsored the Electronic Moving Map Evaluation program to investigate the applicability of presenting detailed map information on a high-resolution, color CRT. Selected 120NM ² areas centered on the English Channel and on Fulda in West Germany were digitized and display- ed. Declutter and zoom capabilities were designed into the system to evaluate the content and scale factors for best pilot perception of the situation. The map was presented relative to aircraft position, speed, and heading in both the North-up and Track-up modes. Several non-map graphics, such as weapon status, were also shown.		

DD FORM 1473
1 JAN 73

EDITION OF 1 NOV 65 IS OBSOLETE

UNCLASSIFIED

SECURITY CLASSIFICATION OF THIS PAGE (When Data Entered)

TABLE OF CONTENTS

SECTION		PAGE
I	INTRODUCTION.....	3
1	Introduction.....	3
2	Digital Graphics Techniques.....	4
3	Data Base Generation.....	4
4	Data Base Size.....	4
5	Graphic System Functional Architecture.....	4
II	MAP DISPLAY TECHNOLOGY.....	7
1	Background.....	7
2	Digital Map Techniques.....	7
a	Imaging.....	7
b	Raster and Stroke.....	7
c	Raster vs. Stroke.....	8
3	Raster Graphics.....	8
a	Introduction.....	8
b	Creating a Picture.....	9
III	MAP EVALUATION SYSTEM.....	11
1	Laboratory System.....	11
2	Map Features.....	13
3	Map Digitizing Technique.....	15
a	Graphics Plotter.....	15
b	Vector Lists.....	15
4	Map Data.....	15
IV	PICTORIAL RESULTS.....	17
1	Introduction.....	17
a	Map Cultural Features.....	17
b	Computed Features.....	17
c	Other Graphics.....	17
V	CONCLUSIONS.....	37
1	Recommendations.....	38
2	Program Phases.....	38

2218
COPY
INSPECTED
2

Accession For	
NTIS GRA&I	<input checked="" type="checkbox"/>
DTIC TAB	<input type="checkbox"/>
Unannounced	<input type="checkbox"/>
Justification	
By _____	
Distribution/ _____	
Availability Codes	
Dist	Avail and/or Special
A-1	

LIST OF ILLUSTRATIONS

FIGURE		PAGE
1	Comparison of Graphic Techniques.....	5
2	Electronics Map Display Functional Diagram..	6
3	Laboratory System Interconnect Diagram.....	12
4	Map Display Data Format.....	16
5	Paper Map (1:500,000 TPC) and Electronic Map (a) All Information Displayed (41,000 Vectors); (b) Decluttered to Cities, Divided Highways, Airports, Lakes, Flight Path Overlay (10,000 Vectors).....	21
6	West German Map - Cities, Divided Highways, Railroads, Nav Aids, FEBA.....	22
7	West German Area - with 900 NM ² Patch of Terrain Contour Data in ATTACK AREA....	23
8	West German Area - with Scenario FLIGHT PLAN OVERLAY.....	24
9	West German Area - Climb-Out on Flight Path (a) North-up; (b) Track-up.....	25
10	West German Area - Approach FEBA with Ticks on Flight Path (Arrow is North).....	26
11	ATTACK AREA Terrain. (Green = Low, Red = Mountains) Lakes and River Shown.....	27
12	ATTACK - (a) Approaching Target East of Lake (North up) (b) Radar and Flir "Footprint" overlay on Targer (Track-up, Arrow pointing North).....	28
13	Weapon Status Prior to Attack. Left ECM on Wing Tank Full, (Green = Armed, Yellow = Standby).....	29
14	Weapon Status.....	30
15	(a) Decluttered for Nav Aid Select. (b) Nav Aid Derived present position circle. Nav Radio and Frequency shown.....	31
16	(a) Emergency Declutter to Airports (b) Re- direct to Breitschied.....	32
17	Approach to Breitschied Emergency Airprt...	33
18	(a) English Channel Area - all information shown. (b) Decluttered to Cities, Airports, and Restricted Zones with Flight Path overlay.....	34
19	Modification of Data base to show TF/TA Situation Along Flight Path.....	35
20	Other Graphic Presentation. (a) Threat Penetration. (b) Nav time Block and Time Ticks.....	36

SECTION I
INTRODUCTION

Digitally stored graphics have recently become viable for cockpit display as a result of process or speed and memory technology developments. The Electronic Moving Map Evaluation program provides a measure of the capabilities available. The program stressed the evaluation of data-base size, graphics speed and information content for the tactical aircraft.

Program Scope - Within the program, the main efforts involved:

- a. Digitization of map information
- b. Display of the map
- c. Evaluation of the data base
- d. Determination of the system architecture
- e. Extrapolation of state-of-the-art graphics speed for high performance aircraft.

The maps selected by the Air Force included the English Channel area, the Fulda area in Germany and the Ohio area including Cincinnati, Dayton and Columbus. The map display evaluation information included the following areas:

- Features (Lakes, Roads, Rivers, Cities, etc.)
- Color
- North Up - Track Up
- Zoom
- Coordinate Rotation
- Translation
- Digital Data Base
- System Mechanization

In each, quantification of the parameters affecting the future display was investigated.

A general purpose, high resolution RAMTEK 9400 was used to visually evaluate these efforts. No attempt was made to do a Man-in-the-Loop simulation, but it is anticipated this will be the subject of future efforts.

1.2 Digital Graphics Techniques

Raster and Caligraphics (Stroke) are the two major techniques available for display of digitally stored information. Within the Raster Graphics area, vector and imaging techniques must be considered. Since flexibility (decluster) is important to the situation display, vector graphics was chosen as the basic approach to be used. Figure 1 shows the comparison of imaging, raster and stroke systems. An explanation of those techniques is given in section 2 of this report.

1.3 Data Base Generation

Digital data bases such as the Digital Land Mass system and others are being compiled. However, the identification of general map cultural features will not be available in the near future, so digitization of features from normal paper maps was done. This was accomplished by using precision X-Y plotting graphics equipment to generate digital data representing each feature to be displayed.

1.4 Data Base Size

For the 120 NM² areas chosen, the German map required the largest data base. In excess of 41,000 X-Y points were generated to depict all detail on this map. With a 16 bit word representing X and Y, this represents storage of 160K bytes which is not large by today's memory capabilities.

1.5 Graphics System Functional Architecture

The Raster Graphics System to draw maps is shown in figure 2. The "Host" function handles the outside world (I/O) from position and heading sensors to the extraction of map data from remote mass memory devices. The information processing section includes assembly of the "display list" being used. The Graphic Generator determines the information to be used for the display after the total information has been coordinate rotated and translated relative to the aircraft motion. Within the "Generator" function, the pixels (smallest picture element) are computed for presentation on the display. The video generator stores the pixel information which is translated to video format for refreshing the display. The speed requirements of updating the map faster than 10 times per second will dictate very high speed processing for compiling the display list, and doing the windowing and clipping. The pixel computation (vector draw into Memory) will impose the maximum speed requirement since it has been determined that pixels must be computed at 100-150 nsec per pixel rate. It is within the component state-of-the-art to attain the speeds required.

	RASTER GRAPHICS	STROKE	IMAGING
DATA BASE (Memory)	Low	Low	Very High
REFRESH RATE (Non-Flicker)	Excellent (60 Hz)	Variable	Excellent (60 Hz)
UPDATE RATE	<0.1 Sec. (>50,000 Vectors)	<0.025 (Under 1,000 Vectors)	Depends on Memory Re- Load Timing
DETAIL (Number of Features)	Good	Poor	Excellent
DECLUTTER	Excellent	Excellent	Poor
ZOOM	Excellent	Excellent	Poor

Figure 1. Comparison of Graphic Techniques

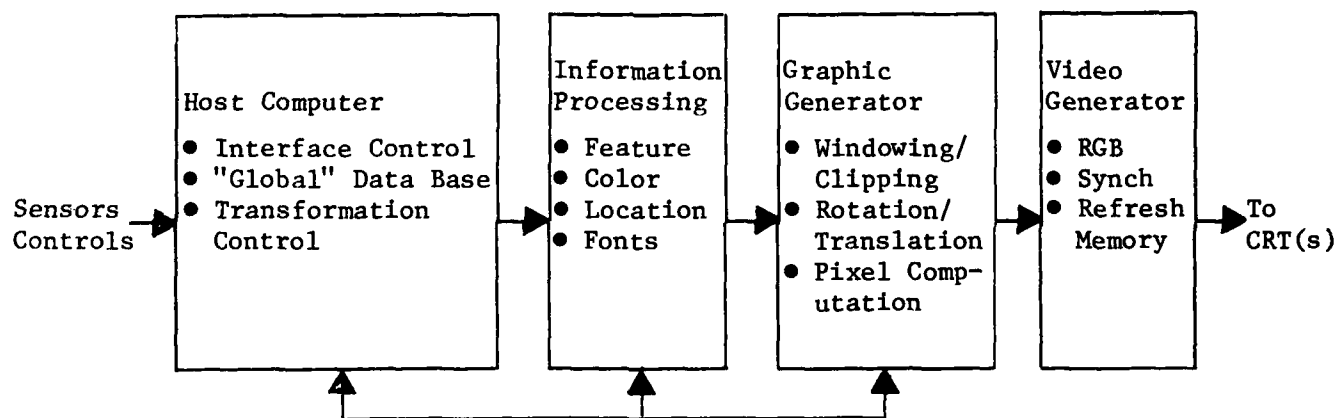

Figure 2. Electronic Map Display Functional Diagram

SECTION II

MAP DISPLAY TECHNOLOGY

1. Background

Paper maps have been in existence for hundreds of years and the use for navigation is well established. In recent years, the advent of small cockpits and crews has generated innovations including servo driven roll maps and electro-optical projection of film recorded maps to eliminate the handling of bulky paper maps.

Now, the digital technology available makes digital storage and reproduction of maps viable. To optimize this application, the choice of graphic techniques must include memory minimization and graphics flexibility for the airborne system.

2. Digital Map Techniques

Within the graphics arena, there are three basic techniques available:

- a. Imaging
- b. Raster Graphics
- c. Caligraphics (Stroke)

Each has its advantages and disadvantages which will be explained in the following sections.

(1) Imaging - This technique involves the storage of each pixel (smallest picture element) for the resolution required. Normally, the data base covers a much larger area than the "viewing window" allowed on the display so the display can be panned over the area covered for relative motion of the aircraft.

Very high fidelity pictorial presentations can be shown with imaging systems, but the penalties are very large data base (memory) requirements and an inflexible display in terms of declutter (adding and subtracting features from the display). As a result, imaging was not considered for the map display evaluation.

(2) Raster and Stroke - These techniques are combined here because they both involve the use of vector draw. That is, the data is stored as vector end points and the graphics system cause the line between each end point to be drawn on the display. The data stored is very small as compared to imaging and the selection of the vectors to be drawn can provide a completely flexible approach where any one or any group of vectors can be drawn according to the detail need for a particular situation.

(3) Raster vs. Stroke - The selection of raster graphics over stroke was based on several system considerations associated with the moving map evaluation. The overriding limitation of stroke involves the number of vector segments that must be used to display a complex map. With even a very high sweep speed stroke, only a few hundred vectors can be drawn before the persistence of the phosphor requires the picture to be redrawn (to eliminate undesirable flicker). As will be shown, detailed maps may require 50,000 or more vectors which greatly exceed stroke capabilities.

In addition, the stroke monitor must be deflected by linear amplifiers requiring excessive power as compared to resonant raster monitors.

Another feature of the raster system is its compatibility with matrix displays such as flat plate L.E.D.'s. Since the picture to be displayed is stored in a bit-mapped refresh memory, the display is directly compatible with any matrix display.

3. Raster Graphics

(1) Introduction - Raster graphics is a method of using a digital computer to create symbology on a display surface. The display is a matrix of dots or picture elements (pixels), arranged in a square or rectangular pattern, and the picture on the display is created by lighting each pixel with a certain color or intensity.

The display resolution is determined by how many pixels there are along each axis of the display matrix. It is possible to use discrete elements, such as LED's, to form the matrix, or it may be created on the face of a CRT by sweeping an electron beam across the tube from left-to-right and top-to-bottom to cover the matrix area (raster). The beam is modulated to control the color or intensity of each pixel. If a CRT is used as the display device, the beam must continually scan, or refresh, the matrix area because of the short persistence of the phosphors on the face of the tube. The refresh rate must be high enough to prevent the phosphor from decaying between refreshes and causing an annoying problem known as flicker.

The symbology on the display is defined by digital information stored in a memory, commonly referred to as refresh memory. A "plane" of refresh memory is an area of memory that has one bit corresponding to each pixel on the display surface. When the display is refreshed, the information in refresh memory is serialized and synchronized with the beam scan to turn the beam on or off at each pixel position. A single plane of refresh memory can produce only a single-color, or monochrome, display because each pixel can be either on (a "1" in refresh memory) or off (a "0" in refresh memory). If a multi-color or variable-intensity monochrome display is desired, more than one plane of refresh memory

must be used, creating a three-dimensional memory array. The number of colors or intensities that can be produced is determined by how many planes of refresh memory are used. Three planes of refresh memory, for example, can produce an eight-color display.

(2) Creating a picture - In order to create a picture on the display, data must be written into refresh memory. Three primary elements are used to create pictures:

1) Vectors. These are straight line segments drawn between two points on the display. The vector start point can be specified by a positioning instruction:

MOVE (X₁,Y₁).

This instruction initializes the vector generator to begin drawing the vector at the point (X₁,Y₁). When the MOVE instruction is followed by a vector draw instruction:

DRAW (X₂,Y₂)

a vector is drawn to point (X₂,Y₂). The vector generator must determine which pixels lie closest to the straight line between the vector start and end points and write into the refresh memory bits corresponding to those pixels. If several consecutive DRAW instructions are given, the result will be linked vectors, where the start point of each vector is the end point of the preceding vector.

In many cases, it is desirable to draw dotted or dashed lines, called textured vectors. Textured vectors can be produced by providing a means of specifying a repeating pattern of 1's and 0's to the vector generator. When the vector pixels are computed, only those with a "1" in the texture pattern will be written into refresh memory. For example, if the 16-bit pattern:

0101010101010101

is specified, the vector generator will write only every other pixel into refresh memory, resulting in a dotted line. The pattern:

1110111011101110

will generate dashed vectors with dashes 3 pixels long and one pixel space between dashes. (A pattern of all 1's will cause the vectors to be solid lines.)

One final word about vector drawing instructions. It should be possible to specify both MOVE and DRAW instructions with either absolute or relative arguments. The absolute form of the draw instruction:

DRAWA (X,Y)

will draw a vector from the start point to the coordinate (X,Y). The relative version of the draw instruction:

DRAWR ($\Delta X, \Delta Y$)

will draw a vector to an end point offset from the start point by ΔX and ΔY .

In practice, a subroutine of relative MOVE and DRAW instructions can be used to define a sub-picture, then this sub-picture can be drawn anywhere in the picture by setting the starting point with an absolute MOVE instruction.

2) Filled Polygons. These picture features are generated by defining a series of linked vectors that form a closed polygon. Circuitry in the graphics processor translates this outline to a series of horizontal or vertical vectors, spaced one pixel apart, that form a solid area on the display within the boundaries defined by the polygon.

3) Alphanumeric Characters. Text can be displayed by specifying to the graphics process a string of character codes. These codes may be standard ASCII codes which will produce pre-defined character symbols on the display, or special codes that allow user-defined symbols to be displayed. These programmable fonts are defined by the user as a matrix of 1's and 0's.

The font matrix can be written into refresh memory as though it were separate horizontal vectors, positioned one below the other, with each vector textured as defined by one horizontal line of the font definition. Text is positioned on the display by using MOVE instructions.

From the preceding discussion of the primary picture elements, it can be seen that all pictures, even those with filled polygons and alphanumeric text, can be generated using combinations of a single, basic component -- textured vectors.

The primary advantage of constructing pictures using only vectors is the speed with which the picture can be written into refresh memory. It is possible to design special high-speed digital circuitry that processes MOVE and DRAW instructions much more rapidly than if the vectors were generated using high-speed processors and firmware.

This speed advantage is especially important when the graphics application requires that the picture be updated frequently in order to produce a dynamic display image. When each "frame" of the moving picture can be drawn quickly, the picture update rate is increased, resulting in a smoother motion on the display.

For very dynamic display applications, a double-buffer refresh memory is sometimes used. While the display is being refreshed from picture information contained in one buffer, the other buffer is erased, and the next frame is drawn into it. When the drawing is completed, the buffers are exchanged, and the process continues.

3. MAP EVALUATION PROGRAM

1. Laboratory System.

Figure 3 shows the interconnection of equipment used in the laboratory simulation of the electronic moving map.

A PDP-11/03 host processor was used to control the Ramtek 9400 graphics processor, which generated the map display on a high-resolution color CRT. Program development for the map display was done using the PDP-11/03 and the Digital Equipment Corp. (DEC) RT-11 operating system.

The dual floppy disk drive connected to the PDP-11/03 stores both the host computer program and the map feature data, which is generated independent of the PDP-11/03 computer. To display a map, the control program is first loaded into the PDP-11/03 by the operating system. Next, this program is used to read map data from the disk and convert it into the form of graphics instructions. These instructions are transferred to the graphics processor to draw the map picture.

The keyboard connected to the graphics processor has special-purpose keys which are used to select the map features to be displayed. These keys are implemented so that if a particular map feature is not displayed and the key corresponding to that feature is pressed, the feature will be added to the display. Other keys on the keyboard are used to control map mode (north-up or track-up), map scaling, and centering of the aircraft or cursor.

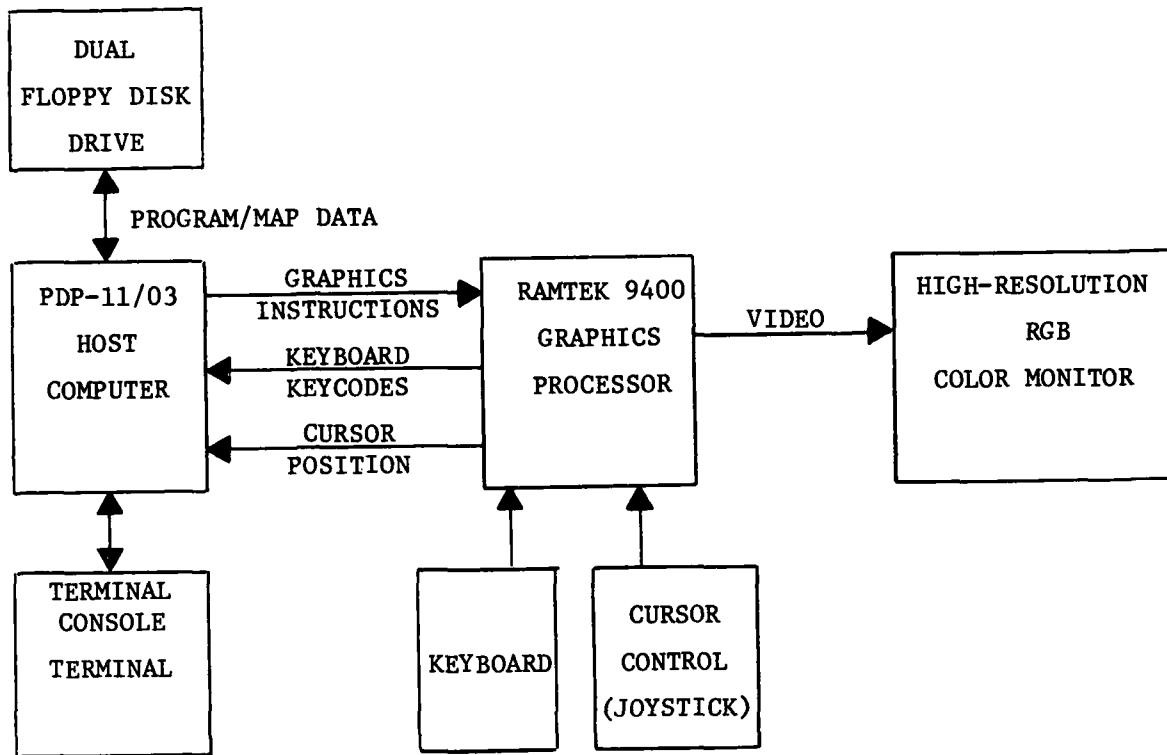

Figure 3. Laboratory System Interconnect Diagram

2. Map Features.

As a requirement of the contract, two 120 NM² areas were digitized; one centered on the English Channel and the second center at Fulda, West Germany.

ENGLISH CHANNEL MAP

<u>MAP FEATURES</u>	<u>X-Y POINTS</u>
Land-Water Boundaries	1995
Large Rivers	32
Small Rivers	7939
Cities	4162
Towns	164
Divided Highways	524
Primary Roads	3025
Secondary Roads	3136
Two-Track Railroads	1342
One-Track Railroads	1357
Power Transmission Lines	1260
Major Airports	17
Emergency Airports	15
Obstructions	74
Restricted Zones	226
	<hr/>
	25,268

WEST GERMAN MAP - FULDA AT CENTER

<u>FEATURE</u>	<u>SYMBOLGY</u>	<u>No.</u>	<u>X-Y POINTS</u>
Lakes	Blue Areas	233	2492
Large Rivers	Blue Line	8	142
Small Rivers	Blue Line	694	13127
Cities	Yellow Areas	425	6066
Towns	Yellow Dots	307	307
Divided Highways	Yellow Lines	82	1167
Primary Highways	Yellow Lines	460	5111
Secondary Highways	Yellow Lines	474	5493
2-Track Railroads	Green Lines	74	1521
1-Track Railroads	Green Lines	213	4067
Power Transmission Lines	Blue/White Lines	227	1607
Major Airports	Solid Magenta Circle	15	15
Emergency Airports	Magenta Circles	56	56
Obstructions	Red Symbol	126	126
Restricted Zones	Red Lines	18	58
			<hr/> 41,355

3. Map digitizing technique.

The map data required for the raster graphics system involves the vector (X,Y) start point and end point in the system "global" coordinates. This corresponds to digital land mass coordinates, map latitude and longitude, etc. Since the most available data is on paper maps, a digitizing technique was developed to plot the features from the maps into the display coordinate system.

(1) Graphics plotter. Use of LSI's graphics plotting equipment provided the semi-automated X-Y data and the necessary resolution to establish the data base. Functionally, the equipment provides a resolution of 0.001 inches on the digitizing tablet which represents about 20 feet on the 1:250,000 TPC maps used.

Operationally, the graphics personnel track the feature (road, river, city, etc.) with a magnifying "puck". For a linked vector line feature, the X-Y end points were recorded when the line deviated from a straight line by more than 175 feet (0.008 inches), thus ending one vector and starting another.

(2) Vector lists. Figure 4 shows the data format used by the graphics equipment. As can be seen, the recorded data include:

- a. Feature type and color
- b. Identification card (river, city, etc.)
- c. Block Count
- d. X-Y Start
- e. Data Byte Count
- f. Intermediate X-Y Points
- g. X-Y End Point
- h. Fill Point (Areas only)
- i. Z (Elevation) Points where applicable
- j. Data organized in 255 word "bags"

These lists were stored in the PDP-11/70 files and transferred to 8" floppy disks for use in the lab equipment.

4. Map data.

For the English Channel area, approximately 26,000 X-Y points (100K bytes) were recorded to describe all features. Digitization required 51 manhours. For the West German map, 41,000 vectors (160K bytes) were required with a 54 manhour expenditure. The difference in vector count is the result of a rather large area of water in the Channel area which required only boundary information in the data base.

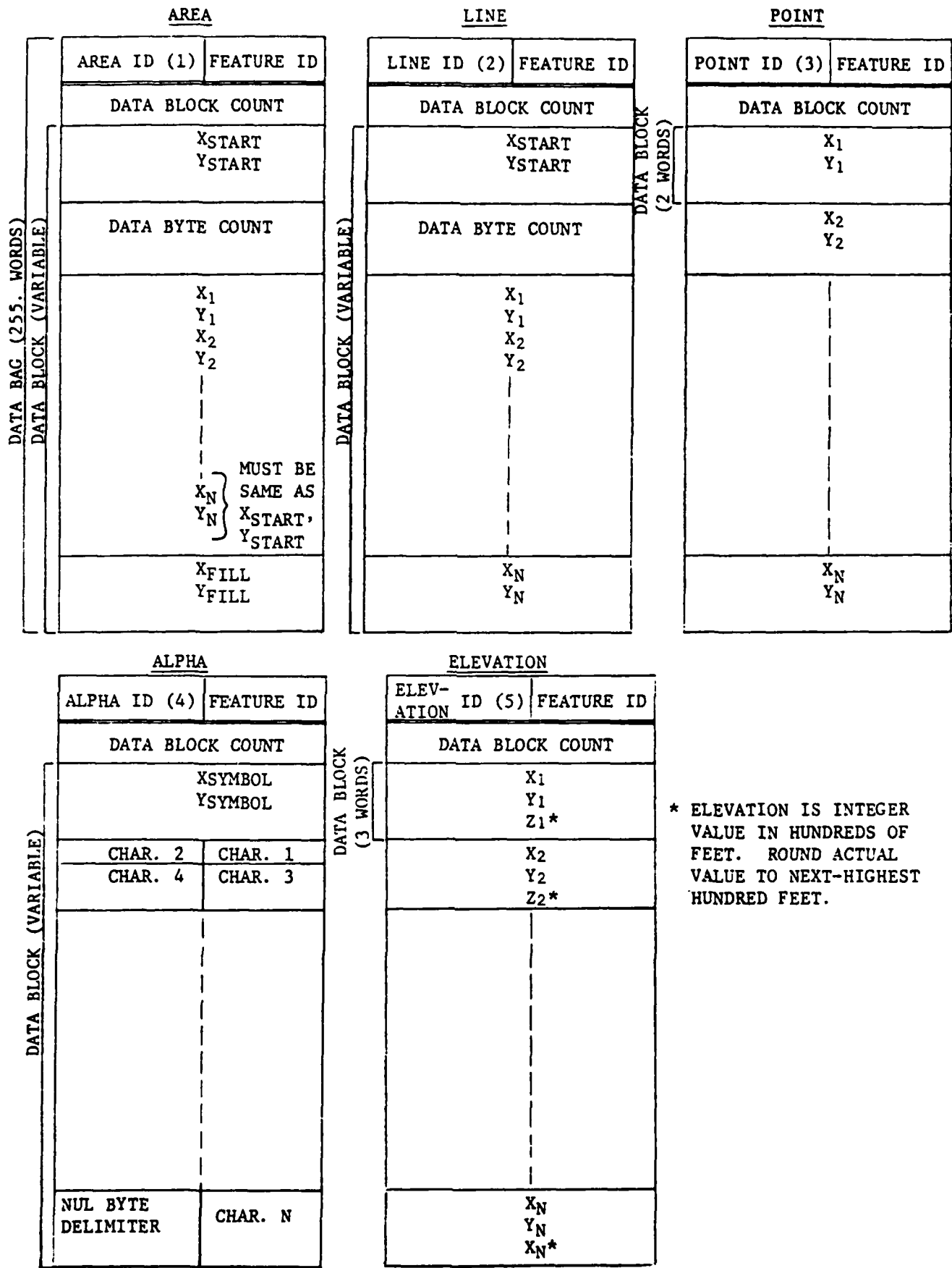

Figure 4. Map Display Data Format

Two important aspects of the map display effort become evident from these efforts:

- a. The data base for a map is not large (not megabytes)
- b. Even manually derived data bases are feasible for a given area in terms of manhours required.

As cultural features become available through DLMS and other digital data, the extraction of the X-Y data for the graphics system will become automated.

Techniques such as Run-Length Encoding and Pattern Recognition will play an important part in this number crunching.

PICTORIAL RESULTS

1. Introduction

The following photographs (figures 5 through 20) taken of the RAMTEK high resolution monitor illustrate the information formats and variations possible. During the execution of this program, a number of these pictures, as 35 mm slides, were submitted to the Air Force as a part of the progress reports. Included in these submittals was a Fulda Gap attack scenario with accompanying 35mm slides. This scenario follows and representative photographs are included in this report.

(1) Map cultural features. Most of the figures shown represent combinations of features making up the basic map. Each includes the listing of the features used in the particular map presentation.

(2) Computed features. Graphic information that is not normally included on the paper map being digitized, may be programmed in the graphics machine itself. For instance, the one minute marks (time ticks) along the flight path can be computed based on the aircraft position and speed so the pilot can rapidly assess his time to his next waypoint.

(3) Other graphics. Figures 13 and 14 illustrate other graphics that can be called up for information. In this case, the status of Weapons, ECM and Wing Tanks are shown.

Fulda Attack Scenario

SLIDE NUMBER	SCALE (NM ²)	
1	120	Paper Map (1:500,000 TPC) area that was digitized for Moving Map Display
2	120	Decluttered Electronic Map for Mission Planning Cities Airports Emergency Airports Divided Highways Lakes Obstruction Restricted Zones
3	120	First Leg of Mission - From Wiesbaden AF Base (Same detail as Slide #2)
4	120	Second Leg of Mission - Waypoint 3 at E. German Border
5	15	Target Area is road east of lake - All Detail Up
6	120	Third Leg of Mission to Target Area
7	120	Fourth Leg of Mission to Secondary Target Area at Hünfeld
8	120	Fifth Leg of Mission. Navigation back to waypoint north of Frankfurt
9*	120	Sixth Leg of Mission back to Wiesbaden
* Mission Planning Complete - Data Transferred to Aircraft with Data Transfer Module		

Fulda Attack Scenario (Continued)

SLIDE NUMBER	SCALE (NM ²)	
10	15	Climbout from Wiesbaden. Crossing intersection of two divided highways. Cities Divided Highways Railroads Airports Obstruction
11	60	Mid Trajectory Check over City of Mittlesinn
12	120	Declutter to lakes only for Radar Check
13	15	Target Area - Over City of Zella Mehlis
14	--	Weapon State Display 14 MK 82 Triad - Green is Armed; Yellow, Non-Armed 2 Aim 9 Missiles 2 ECM Pods - 1 Active 1 Fuel Tank 1 Napam Bomb
15	--	Weapon State after Attack - Red is Hung Bomb
16	60	Decluttered Egress - Cursor "Hook" Hünfeld Area - for Target Designation - Cities and Roads
17	60	Corresponding Paper Map
18	30	Hünfeld Area with Cities and Roads
19	30	Same area - Cursor on Target Location

Fulda Attack Scenario (Continued)

SLIDE NUMBER	SCALE (NM ²)	
20	--	Weapon State after First Attack. All bombs gone except one that is hung.
21	--	Weapon State - Second Attack - Aircraft Clean
22	120	Aircraft North of Frankfurt. Told to divert to Breitscheid Emergency Airport
23	120	Declutter to Emergency Airports only. Change Trajectory to Breitscheid Area
24	15	All detail - Approach Breitscheid

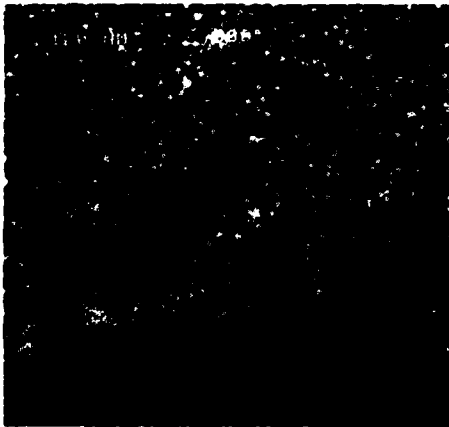
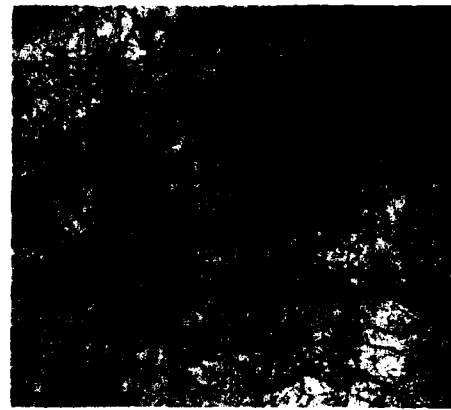

(a.)

(b)

Figure 5. Paper Map (1:500,000 TPC) and Electronic Map
(a) All Information Displayed (41,000 Vectors);
(b) Decluttered to Cities, Divided Highways,
Airports, Lakes, Flight Path Overlay (10,000
Vectors)

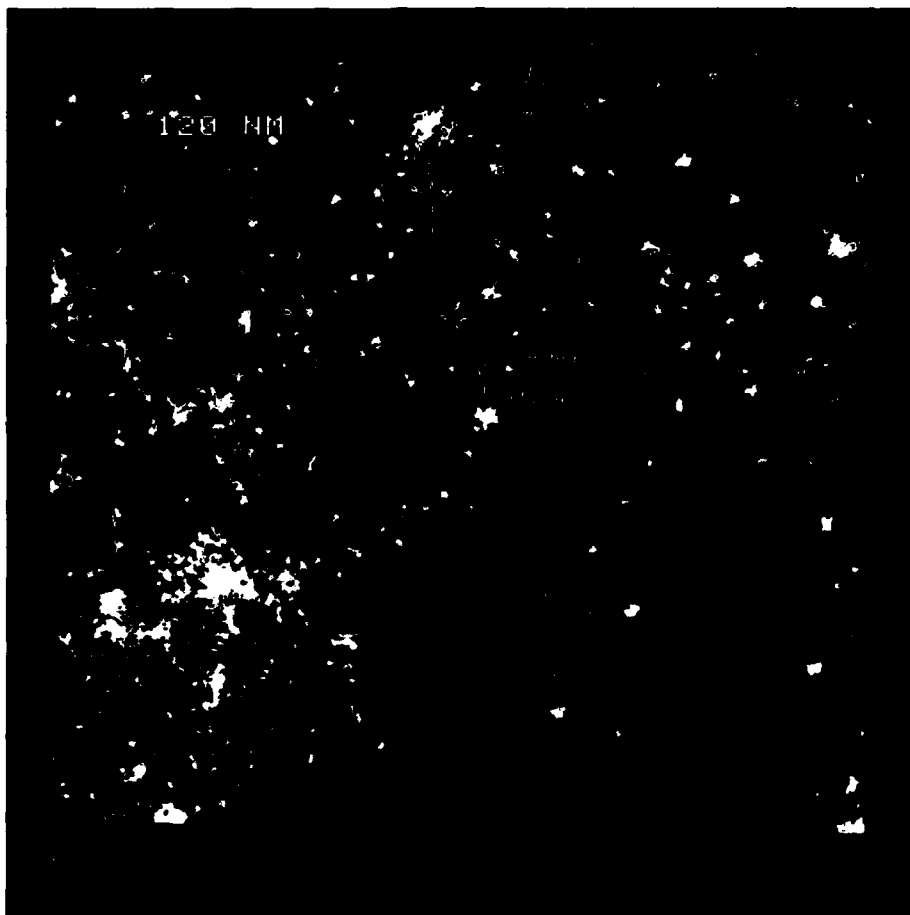

Figure 6. West German Map - Cities, Divided Highways,
Railroads, Nav Aids, FEBA

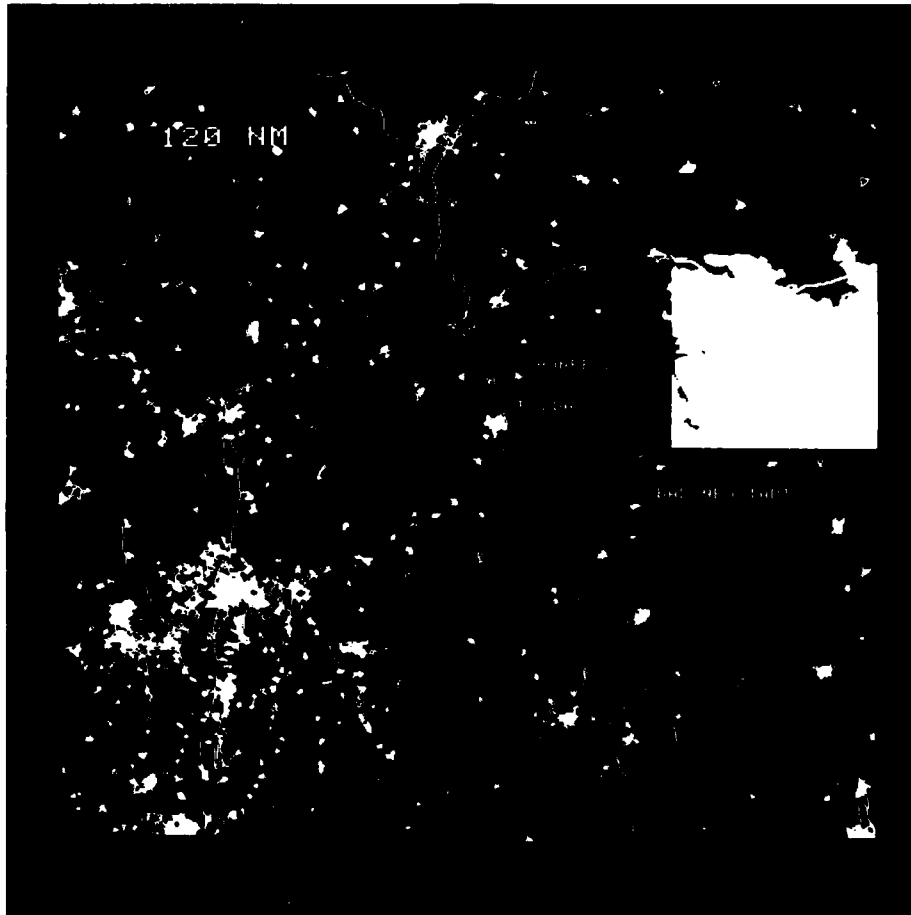

Figure 7. West German Area - With 900 NM² Patch of Terrain Contour Data in ATTACK AREA

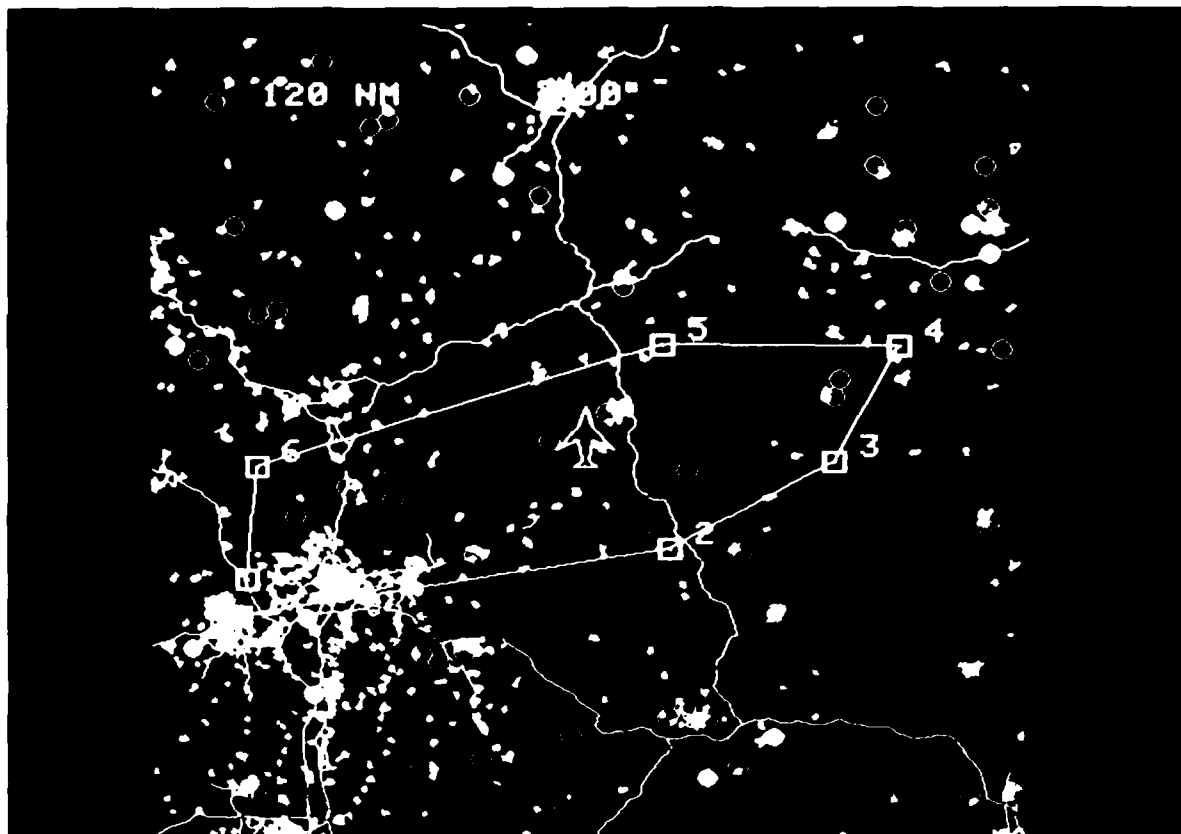
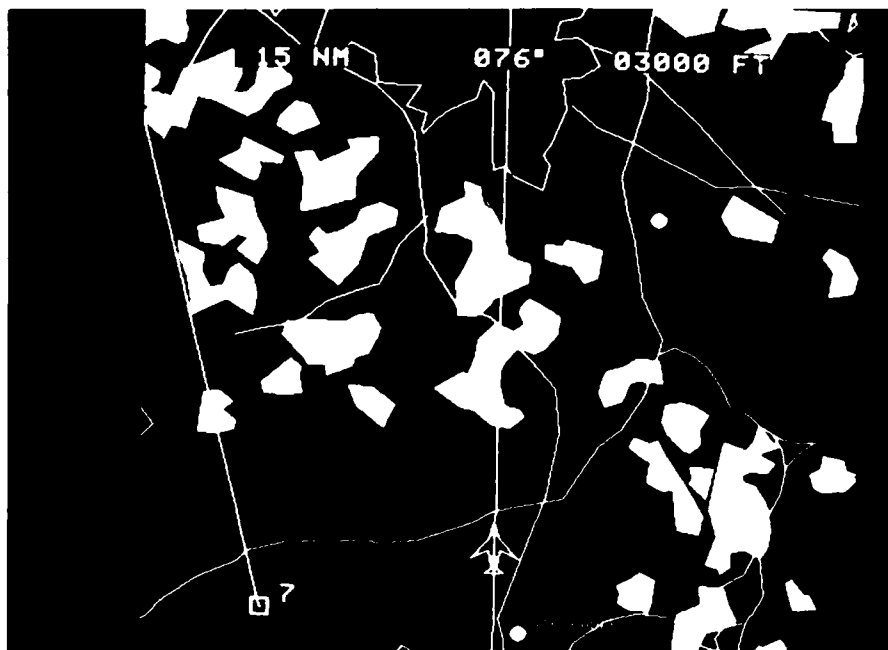

Figure 8. West German Area - with Scenario
FLIGHT PLAN OVERLAY



(a)



(b)

Figure 9. West German Area - Climb-Out on Flight Path
(a) North-up; (b) Track-up

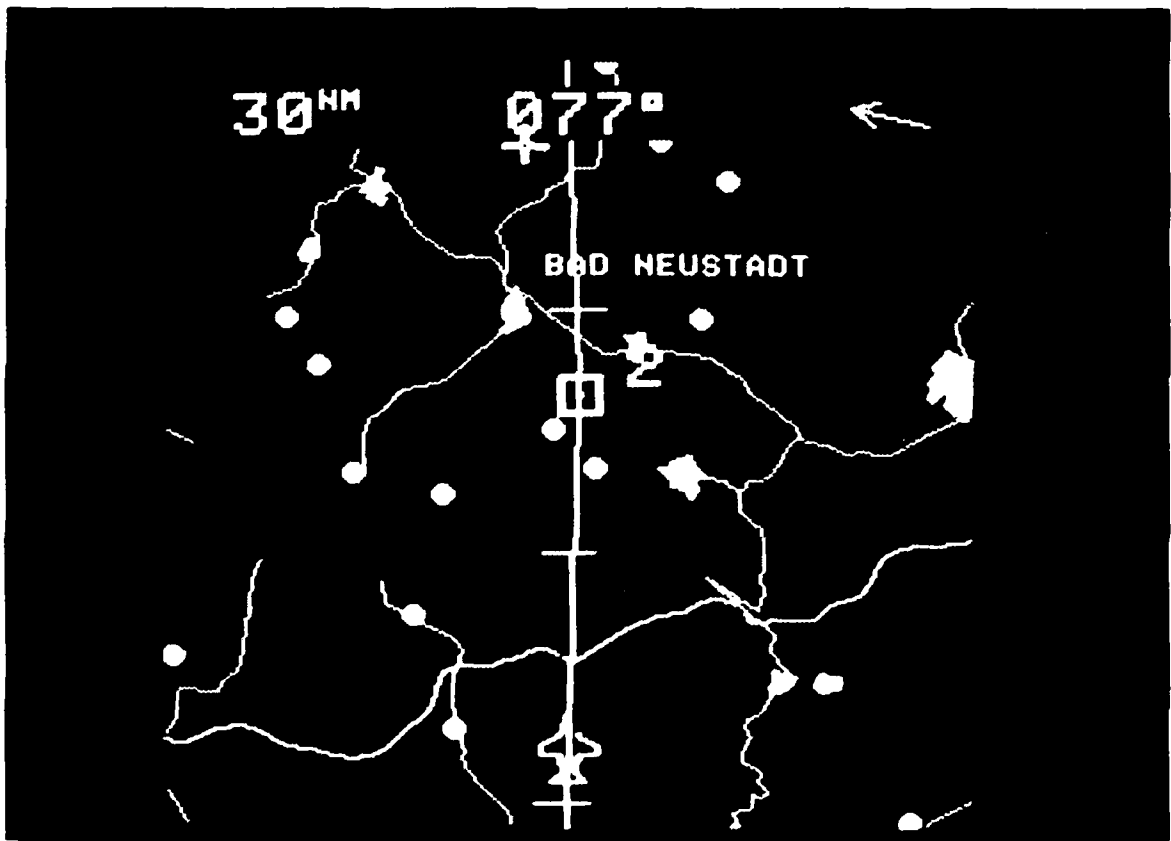

Figure 10. West German Area - Approaching FEBA with Ticks on Flight Path (Arrow is North)

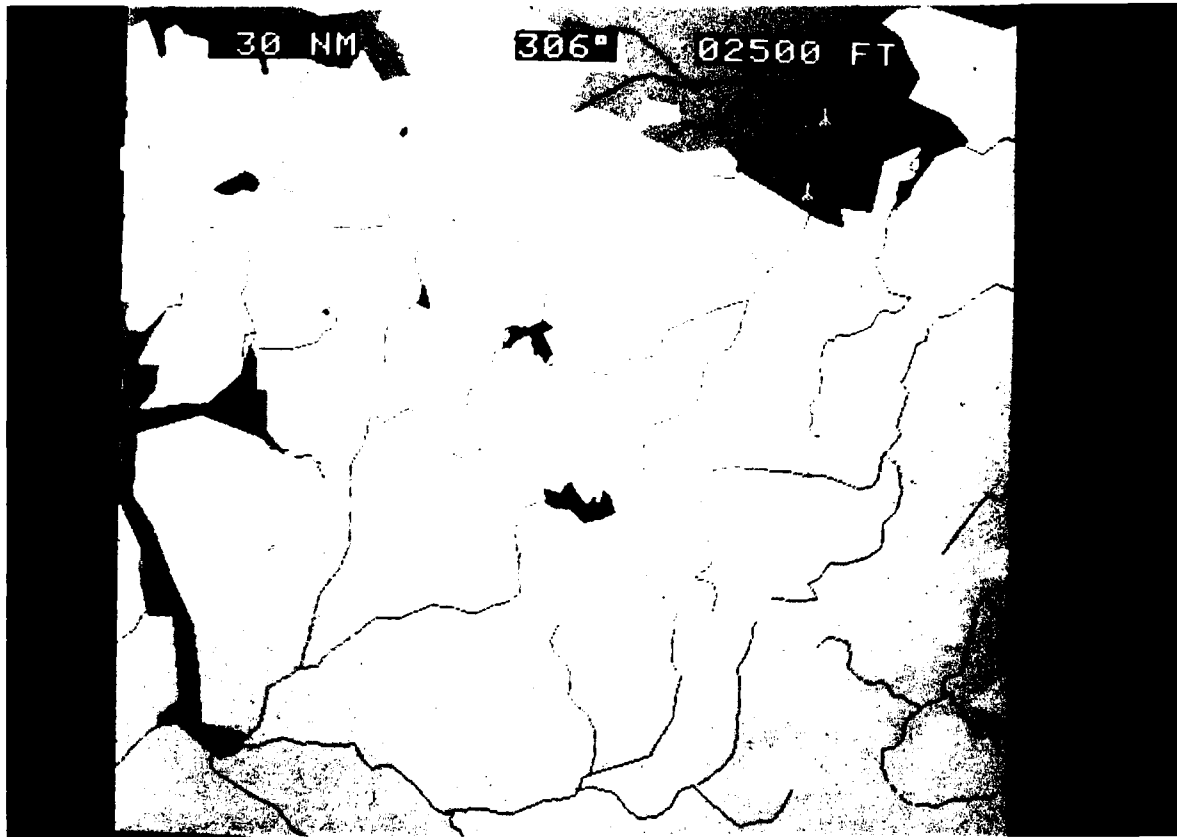
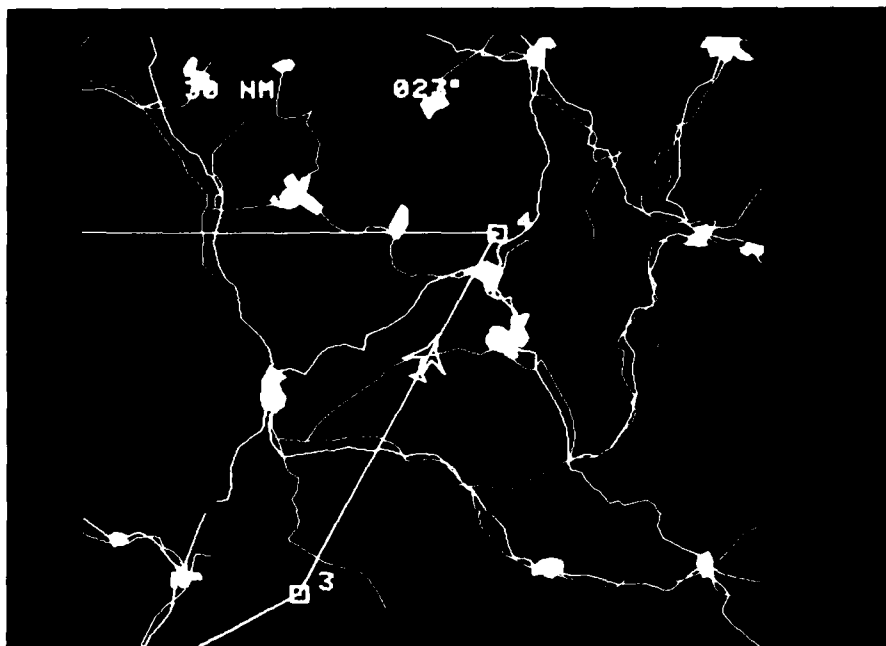
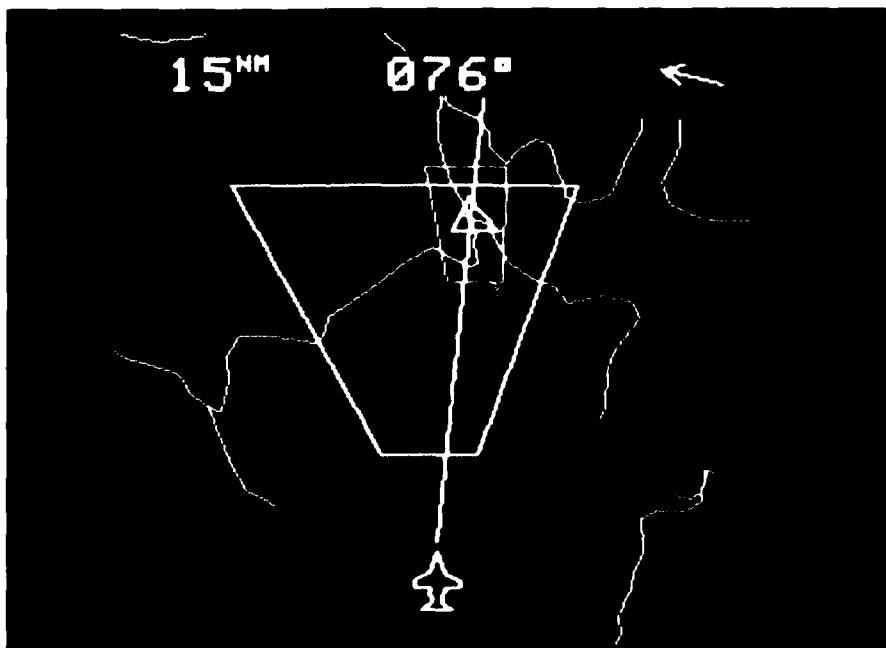

Figure 11. ATTACK AREA Terrain. (Green = Low, Red = Mountains)
Lakes and Rivers shown



(a)



(b)

Figure 12. ATTACK - (a) Approaching Target East of Lake (North up)
 (b) Radar and Flir "Footprint" overlay on Target
 (Track-up, Arrow pointing North)

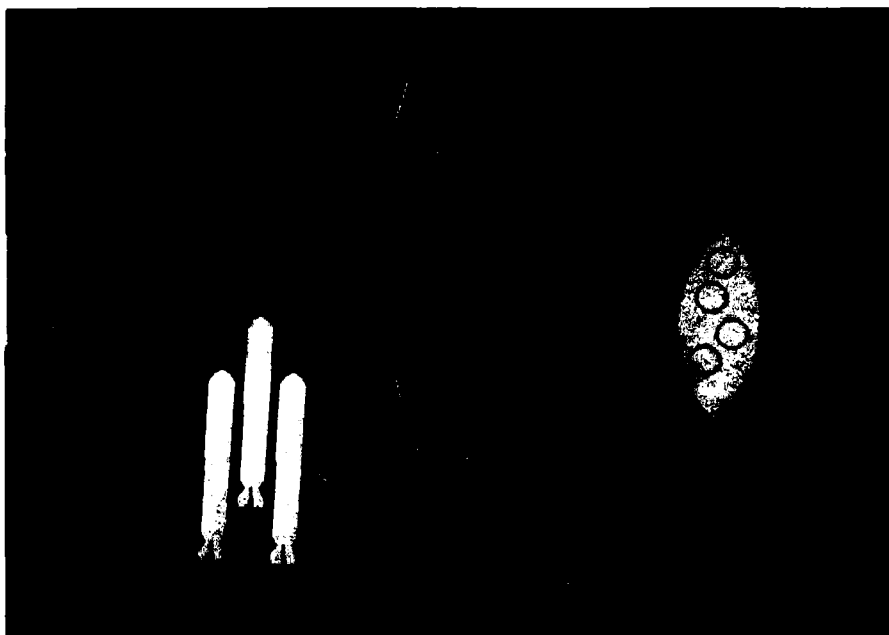
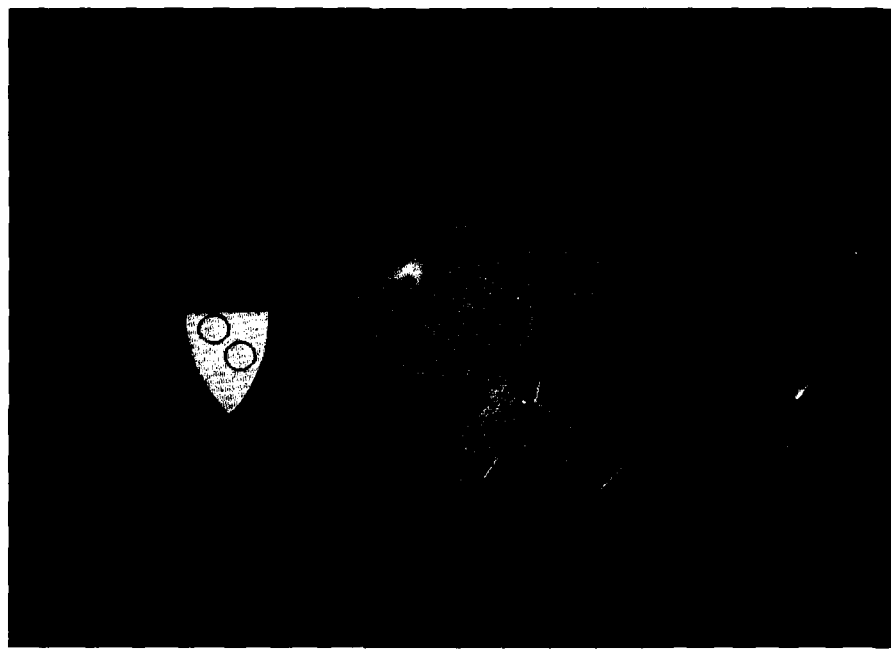

Figure 13. Weapon Status Prior to Attack. Left ECM on Wing Tank Full, (Green = Armed, Yellow = Standby)



(a)



(b)

Figure 14. Weapon Status - (a) After First Attack.
(Red = Hung Bomb). (b) All weapons Dropped, ECM off

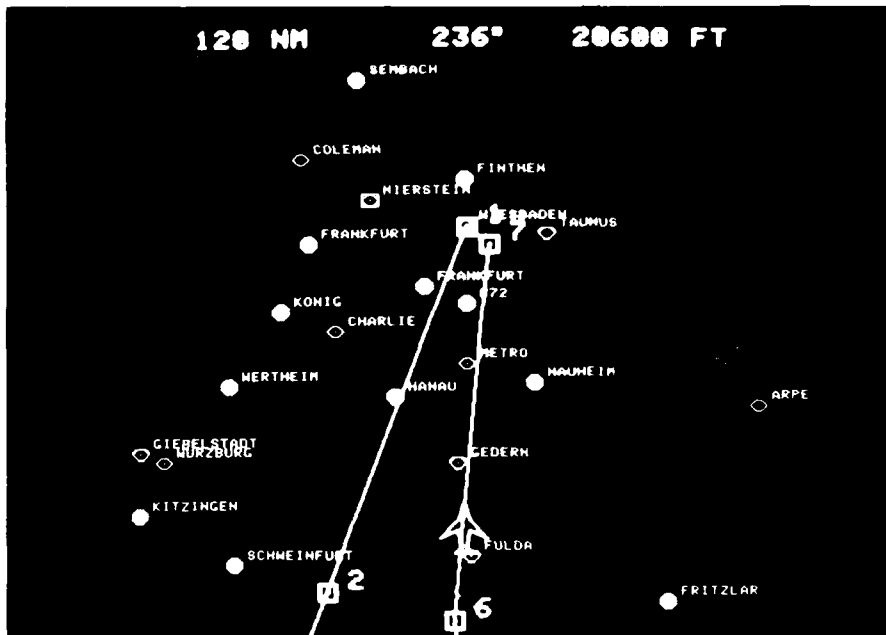

(a)

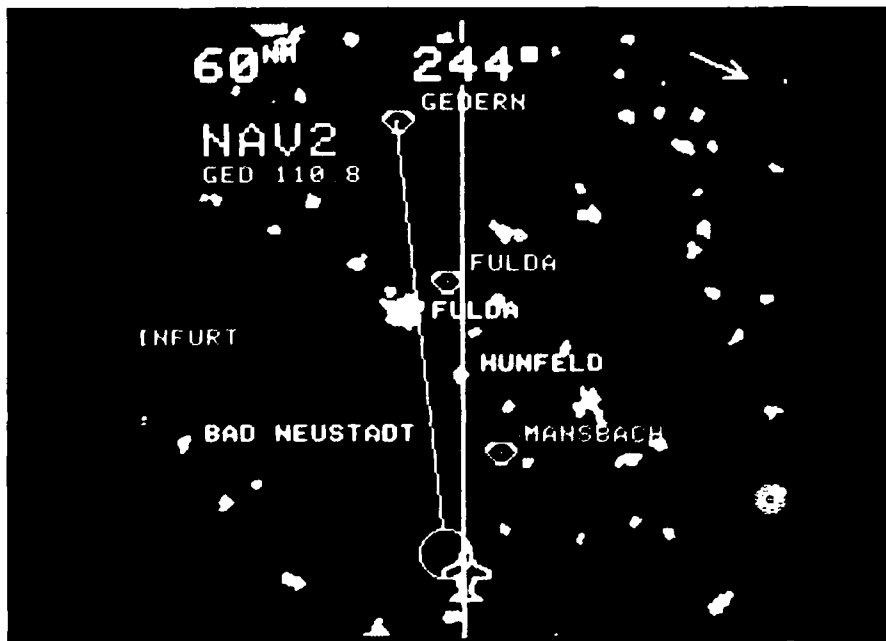

(b)

Figure 15. (a) Decluttered for Nav Aid Select.
 (b) Nav Aid Derived present position circle.
 Nav Radio and Frequency shown.

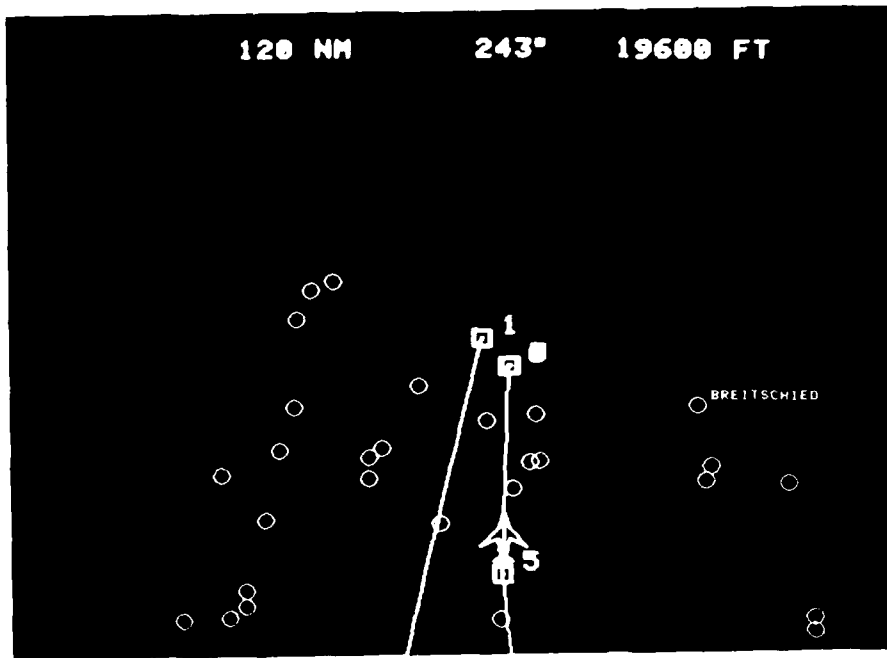

(a)

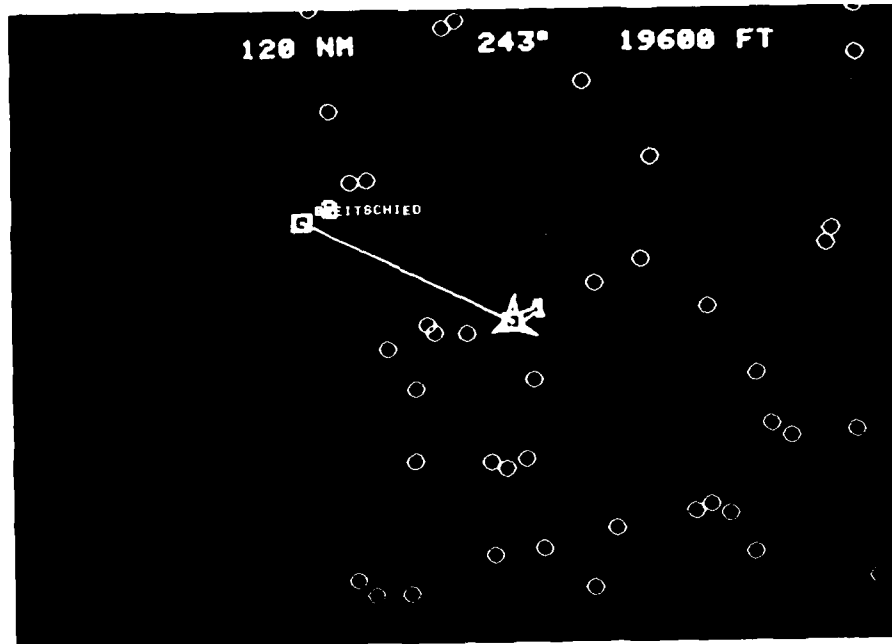

(b)

Figure 16. (a) Emergency Declutter To Airports
(b) Redirect to Breitschied

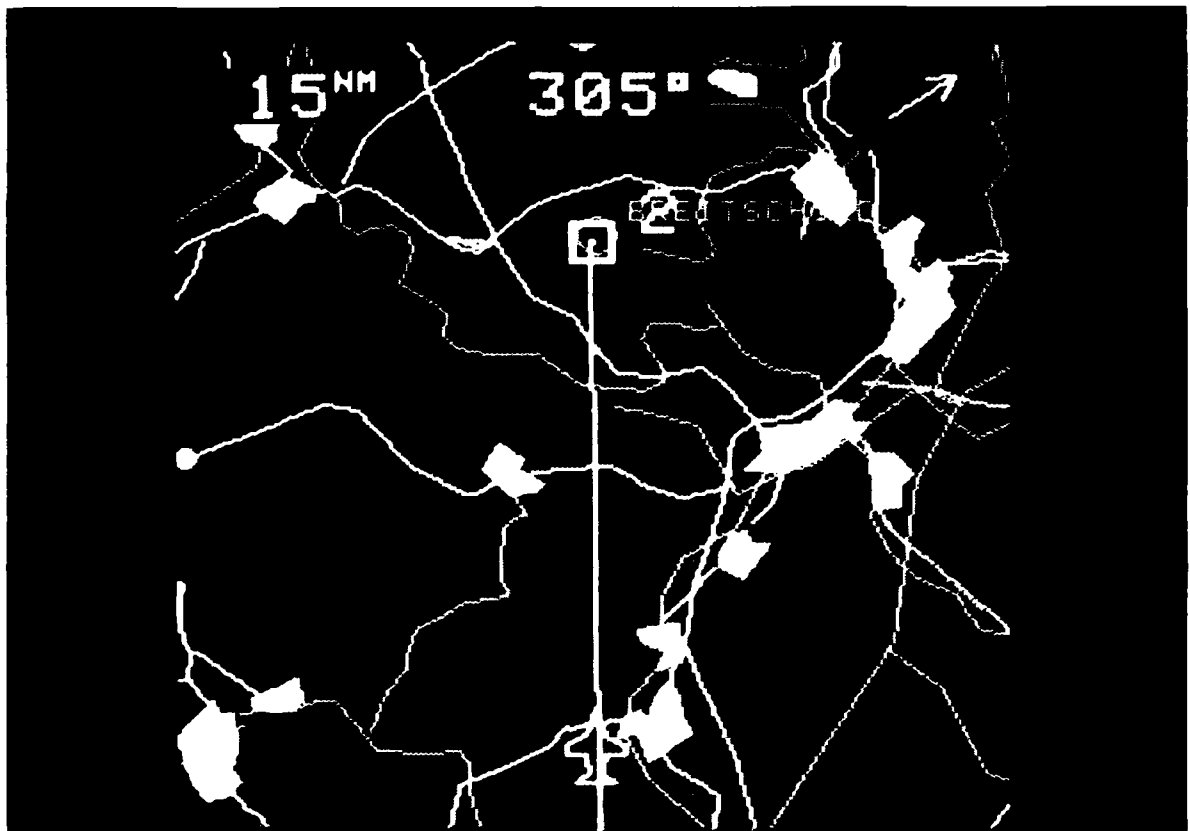
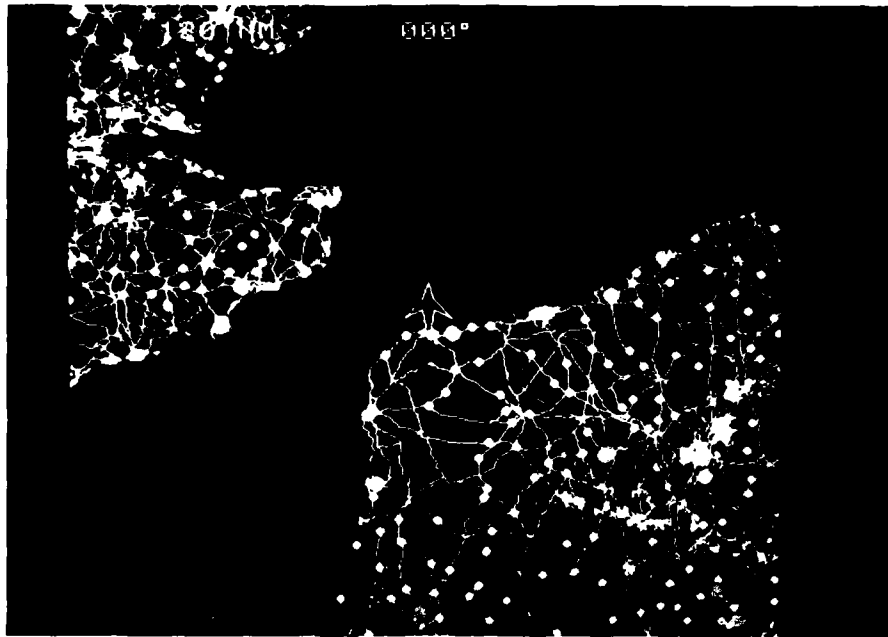
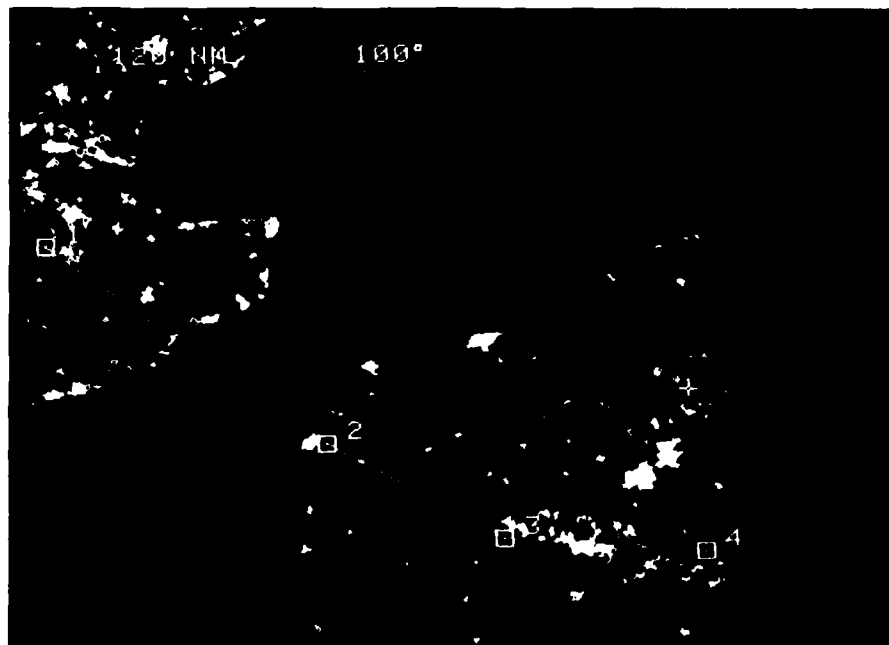

Figure 17. Approach to Breitschied Emergency Airport



(a)



(b)

Figure 18. (a) English Channel Map with all information shown.
(b) Decluttered to Cities, Airports, and Restricted Zones with Flight Path overlay.



Figure 19. Modification of Data base to show TF/TA Situation Along Flight Path

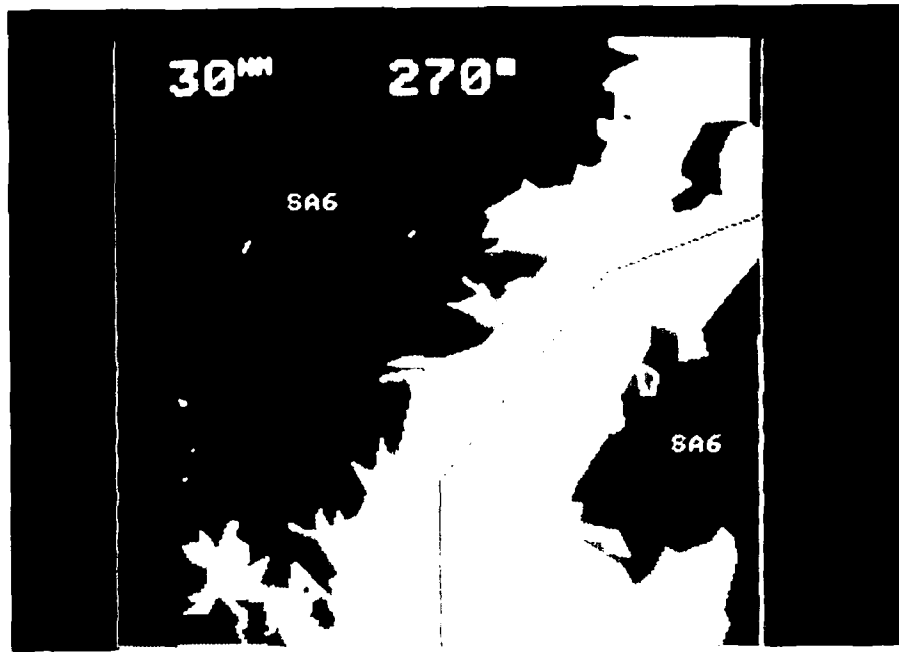

(a)

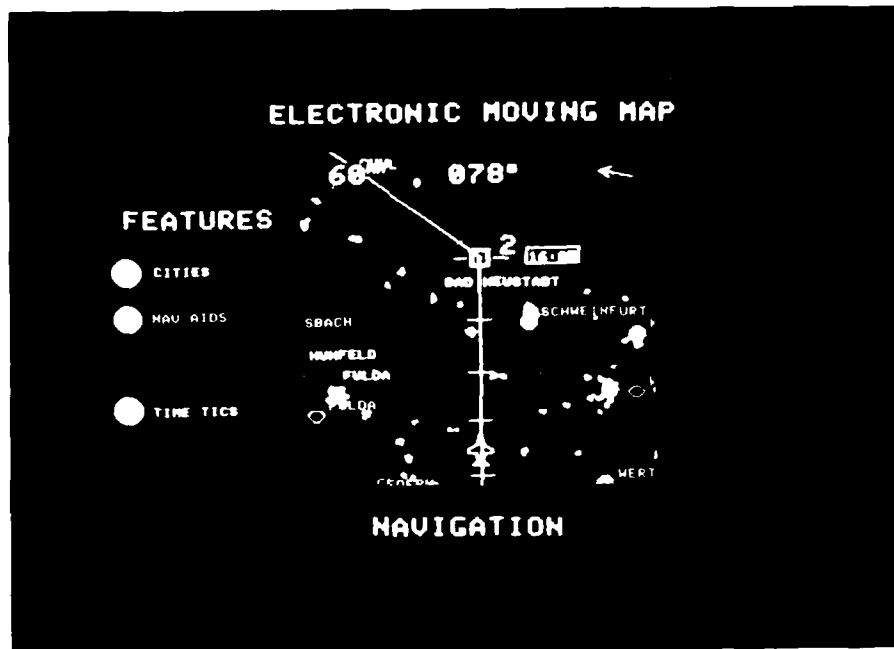

(b)

Figure 20. Other Graphic Presentation. (a) Threat Penetration.
(b) Nav Time Block and Time Ticks.

CONCLUSIONS

Several important facts have been determined during the Electronic Moving Map Evaluation that make it a viable approach to "situational awareness" in the cockpit. Foremost among these is the size of the digital data base. Although the detailed requirements for a given mission are yet to be fully defined, the results thus far indicate that a data base under 256K should handle the tactical mission. This is not a large requirement in today's memory technology.

Digitizing map data was accomplished by x-y plotting features from paper maps. Typically, with all cultural features recorded, a 14,400 square mile (120NM²) area required about 50 manhours. Data resolution was specified at 175 feet (0.008 inches) to get a faithful reproduction at the highest resolution scaling on the CRT. Areas of this size required the recording of 25,000 to 50,000 x-y points. Since data bases, such as the DMA in the future, are x-y in nature, data compaction techniques will reduce them to a comparable level.

Declutter was determined to be multi-faceted. First, data can be selected from the list to present only the information need for the particular mission segment. Color provides discrimination between features and zoom-in expands the picture to effectively reduce clutter.

From the standpoint of the architecture for future "graphics generators", update rate for dynamic displays is the driver. Using the rule-of-thumb that a situation display should be updated no less than 10 times per second, the map must be rotated, translated and redrawn at that rate. When 50K to 100K vectors are involved, the vector generator and the associate manipulation of data must be processed at rates approaching 100 nanoseconds per pixel. This represents extremely high throughput in a multiprocessor system, yet it is within the state-of-the-art.

Future effort in the map display development should include:

- a. High speed graphic processor development
- b. Man-in-the-Loop simulation and evaluation
- c. Flight test evaluation
- d. Full scale engineering

The results of this program have set the groundwork for these efforts.

1. Recommendations

The following recommendations are offered for Air Force consideration.

MULTI - PHASE DEVELOPMENT TASKS

- Generate Digital Data Representing Typical Map Section
- Determine Level of Detail and Resolution Required
- Evaluate Mass Data Base Impact such as DMA & Purple Haze
- Provide Selective Detail/Declutter Experiment
- Integrate System With Compatible Cockpit Color CRT
- Do Man-In-The-Loop Integration With Tactical Flight Management Algorithms
- Size the Airborne Data Base To Define Memory Requirement
- Determine Processor's Speed Requirement
- Build and Flight Test Brass Board System
- Develop Hardware Specification
- Specify Final System Architecture

2. Program Phases

Having completed the First Phase graphics evaluation associated with moving maps and having generated the tools for further evaluation, the following recommendations are offered:

Second Phase

- Use Phase I 2-D Design Tool With Controls To:
 1. Modify Map Detail
 2. Selective Declutter
 3. Control Cursor Position.

- Digitize Other Map Section For Display
- Include Computer Generated Aircraft Dynamics To Evaluate Tactical Considerations
- Evaluate 3-D Mapping Requirements Associated With:
 - 1. I F T C
 - 2. D M A Data Base
 - 3. Purple Haze
 - 4. Tercom
- Evaluate Overall Program Objectives Using Air Force Personnel
- Specify Next Phase Hardware and Software For Man-In-The-Loop Refinements

Third Phase

- Use Tools Developed during Second Phase to:
 - 1. Develop Man-In-The-Loop-Simulation
 - 2. Test and Evaluate A.F. Pilot Response
- Develop basic Breadboard for High-Speed Vector Draw
- Define Crew Interface for Simulation and Flight Test
- Define Architecture for Airborne System

Fourth Phase

- Develop Brass-Board Graphics Generator
- Design and Support Installation and Test
- Evaluate A.F. Personnel Test Response
- Configure Final System and Write Specification