

AD-A146 234

DECELERATION COOLING AND TRAPPING OF ATOMS(U) STATE
UNIV OF NEW YORK AT STONY BROOK DEPT OF PHYSICS
H J METCALF 12 AUG 84 N00014-83-K-0585

1/1

UNCLASSIFIED

F/G 20/8

NL

													END FILMED DTIC

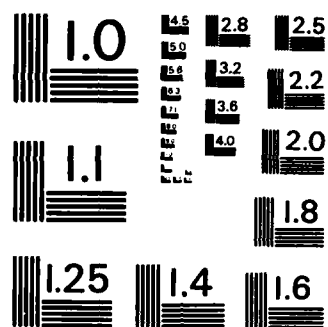

MICROCOPY RESOLUTION TEST CHART
NATIONAL BUREAU OF STANDARDS-1963-A

REPORT DOCUMENTATION PAGE

READ INSTRUCTIONS
BEFORE COMPLETING FORM

1. REPORT NUMBER	2. GOVT ACCESSION NO.	3. RECIPIENT'S CATALOG NUMBER
4. TITLE (and Subtitle) Deceleration, Cooling, and Trapping of Atoms		5. TYPE OF REPORT & PERIOD COVERED Annual Summary Report 7/22/83 - 7/21/84
7. AUTHOR(s) Harold J. Metcalf		6. PERFORMING ORG. REPORT NUMBER
PERFORMING ORGANIZATION NAME AND ADDRESS Department of Physics State University of New York at Stony Brook Stony Brook, New York 11794		8. CONTRACT OR GRANT NUMBER(s) N0001483K0585
CONTROLLING OFFICE NAME AND ADDRESS Office of Naval Research 800 N. Quincy Avenue Arlington, VA 22217		10. PROGRAM ELEMENT, PROJECT, TASK AREA & WORK UNIT NUMBERS 61153N RR011-03-03 NR 407-010
MONITORING AGENCY NAME & ADDRESS (if different from Controlling Office) same as above		12. REPORT DATE 8/12/84
		13. NUMBER OF PAGES 39
		15. SECURITY CLASS. (of this report) none
		15a. DECLASSIFICATION/DOWNGRADING SCHEDULE

DISTRIBUTION STATEMENT (of this Report)

Approved for public release: distribution unlimited.

17. DISTRIBUTION STATEMENT (of the abstract entered in Block 20, if different from Report)

Same as report

18. SUPPLEMENTARY NOTES

19. KEY WORDS (Continue on reverse side if necessary and identify by block number)

20. ABSTRACT (Continue on reverse side if necessary and identify by block number)

We have performed a variety of calculations connected with laser cooling of atoms, many of them relevant to the experiments at NBS on this subject. Some of these have been tested and found to agree well with these experiments. We have designed, built, and tested various devices for use in these experiments. We have also done various calculations relevant to magnetic traps for cooled atoms. These are particularly well-suited for laser cooled atoms.

DTIC
SELECTED
SEP 28 1984
S
A

AD-A146 234

DTIC FILE COPY

DD FORM 1473
1 JAN 73

EDITION OF 1 NOV 68 IS OBSOLETE

S/N 0102-LF-014-6601

SECURITY CLASSIFICATION OF THIS PAGE (When Data Entered)

84 09 21 067

I. PROGRESS REPORT

The original proposal outlined three distinct areas of proposed work. The first of these (section IIA) was the theoretical study of magnetic traps for neutral atoms.

A. MAGNETIC TRAP FOR NEUTRAL ATOMS

We have made considerable progress in this effort. In Appendix A are copies of abstracts describing some of our work that have been submitted to meetings of the A.P.S. (Washington), the D.E.A.P. (Connecticut), and the I.C.A.P. (Seattle).

The first magnetic trap we have studied is the one originally proposed in the N.B.S. Special Publication 653, consisting of a magnetic hexapole lens between two magnetic mirrors. Tom Bergeman has developed an algorithm for calculating the field from the three sources (two mirrors, one hexapole) at any point in space. The resulting computer program allows us to generate field maps, and especially to consider the effects of the fringing fields and other non-ideal aspects of the fields real magnets.

The second part of his studies was the calculation of the orbital paths of magnetic dipoles in this trap. He has studied a very wide range of initial conditions, sometimes over a very tiny grid spacing,

in order to determine the volume of available phase space that produces stable orbits. Many of those plots are on the next few pages.

The conclusion is that this particular configuration is probably not stable enough for us to consider building one. Of course, such a trap made with ideal mirrors and lenses is stable. The effects of the fringing field of the hexapole (spherical aberration) and the azimuthal variation outside the $z = 0$ plane compromise the orbital stability somewhat, but still allow a substantial range of parameters that produce metastable orbits. The serious degradation of the real trap arises from the curvature of the end mirrors. If the solenoids have small diameters, the curvature of the "reflecting" surface eventually returns the atom to the trap at such a large angle that the hexapole can no longer contain it. This is clearly shown in the orbital plots. If the solenoids have large diameters, their fields then extend well into the hexapole lens and severely alter its properties.

We have concluded that this is not the best direction to pursue, but that we should concentrate our efforts in another direction. The most promising configuration is the spherical hexapole or some variation of it (we call it a 'three coil trap'). It has the special advantage of being an absolute trap, rather than simply having dynamical stability.

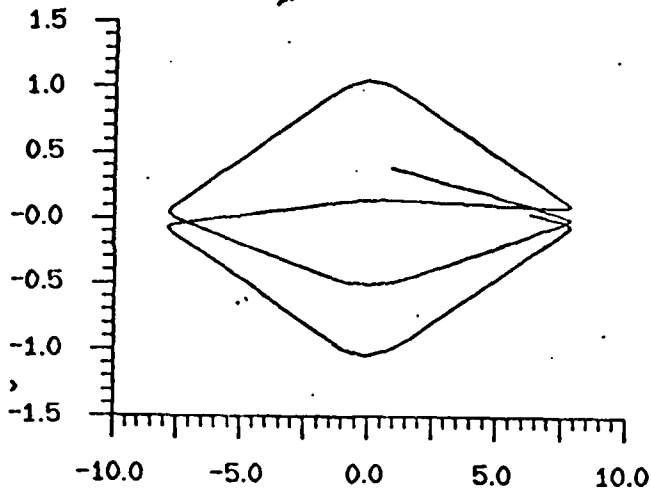

A1 ± 20.05 $V=1000$
NATIME

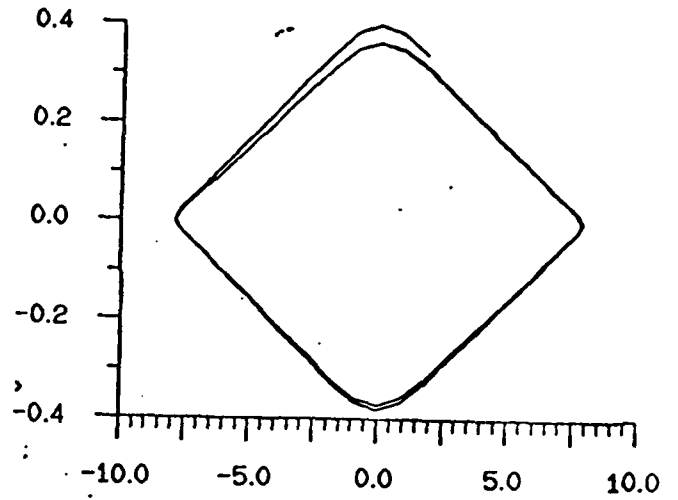

A2 ± 20.05 $V=1000$
SETEO

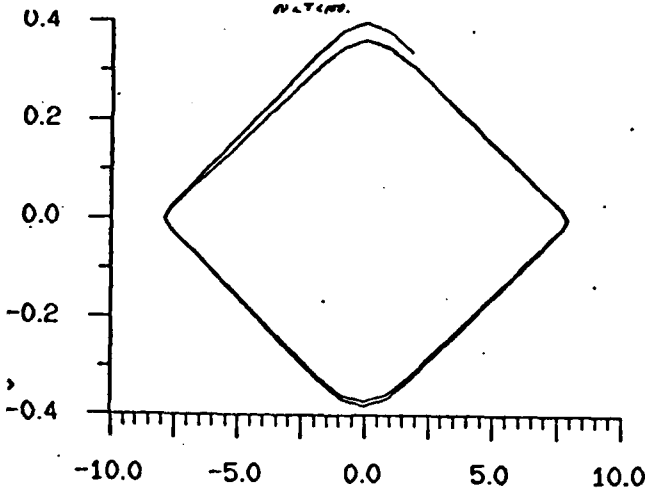

A3 ± 20.05 $V=1000$
SETEO

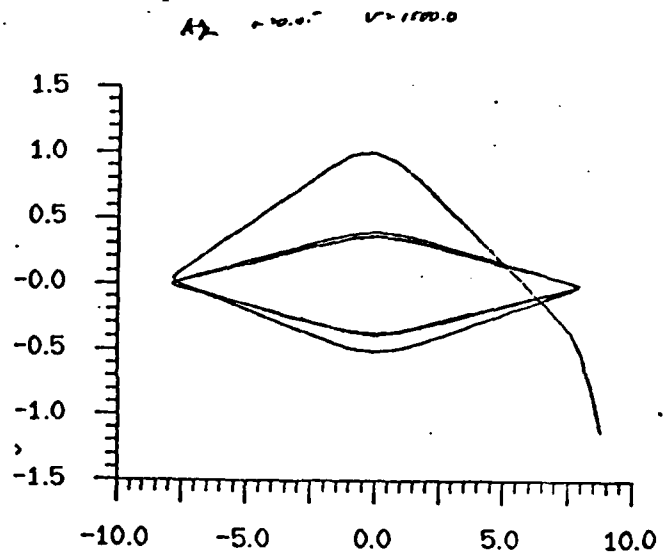

A4 ± 20.05 $V=1000$

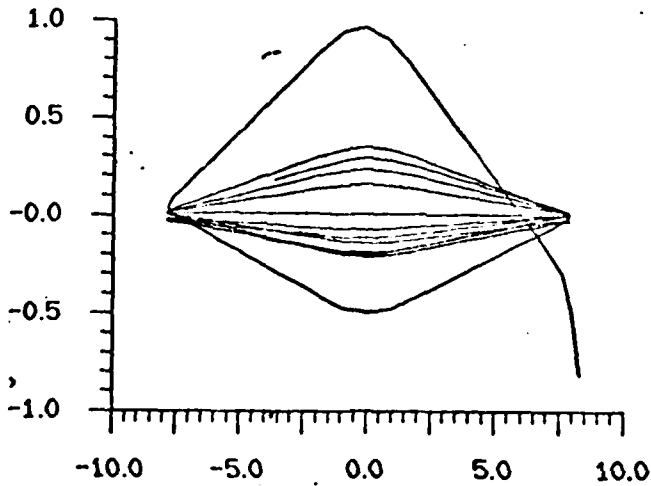

A5 ± 20.05 $V=1000$

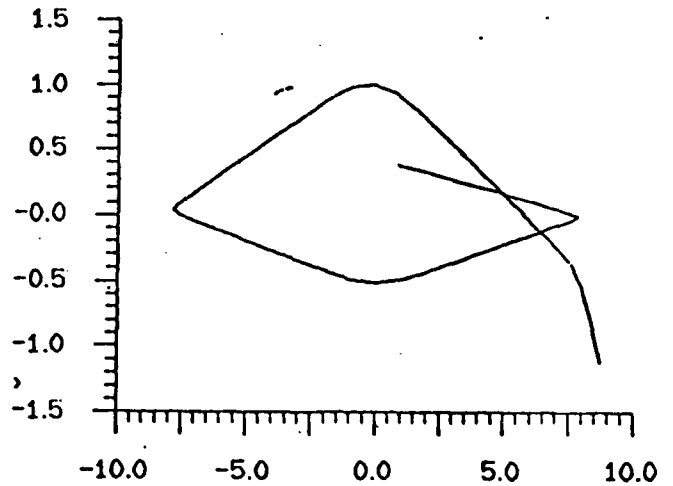

A6 ± 20.05 $V=1000$
NAT

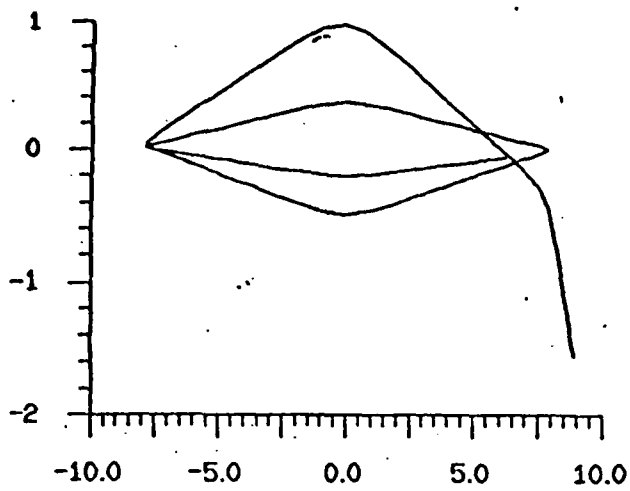

A) 2.004 v=100
in CT

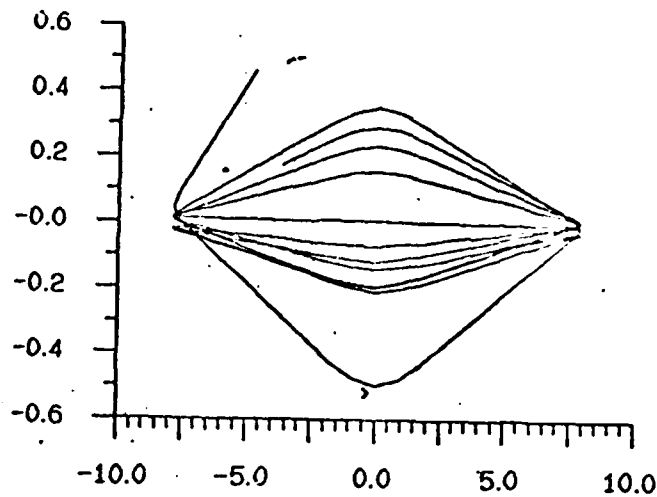

A) 2.004 v=100

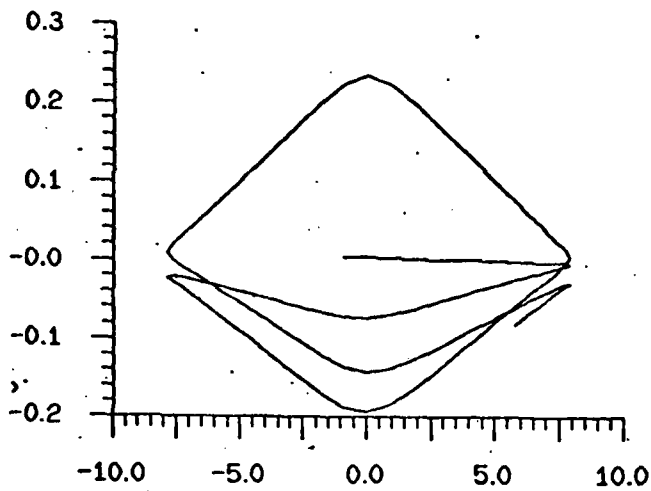

A) 0.4 v=100.0
F=2000
0.250

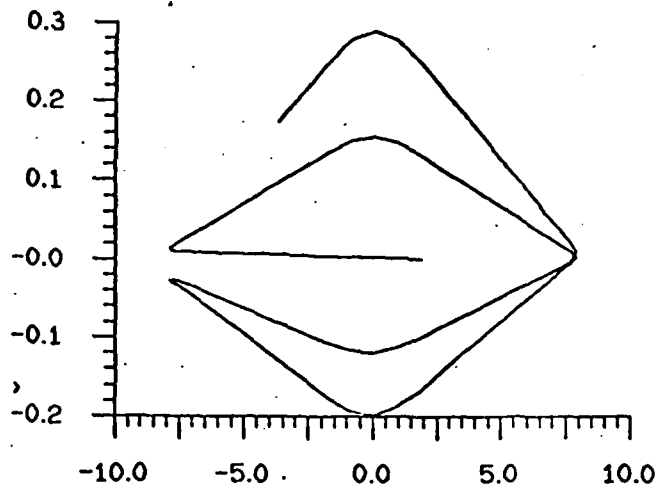

A) 2.004 v=100
5.750

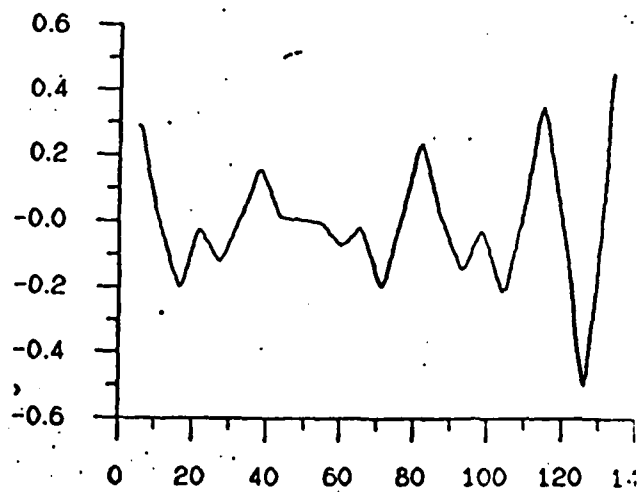
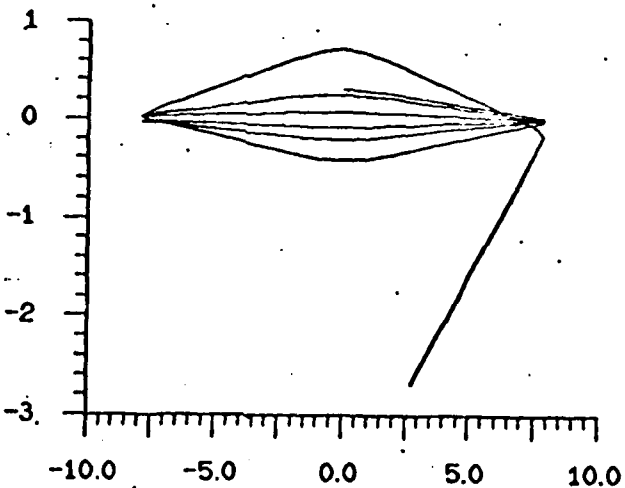

A) 2.004 v=100
v=7

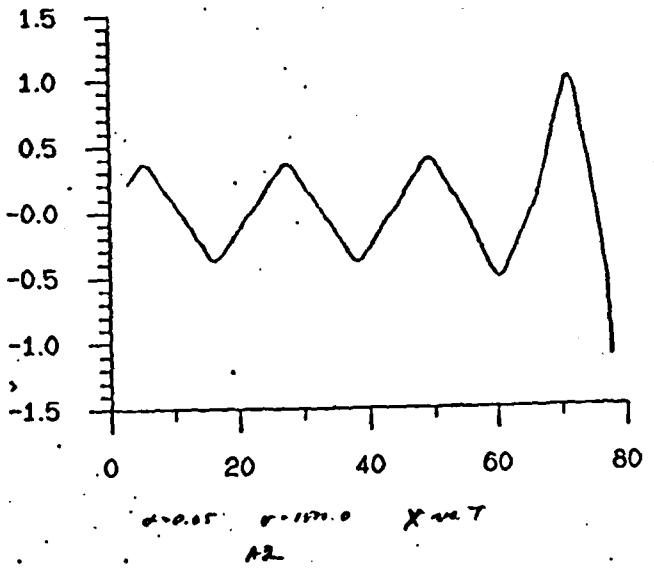
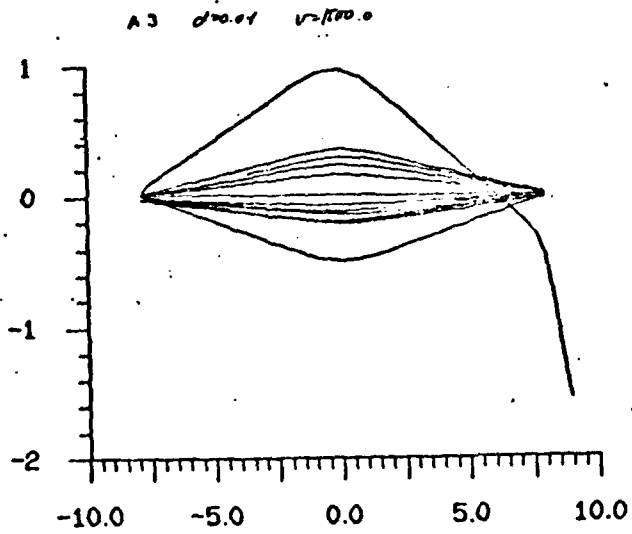
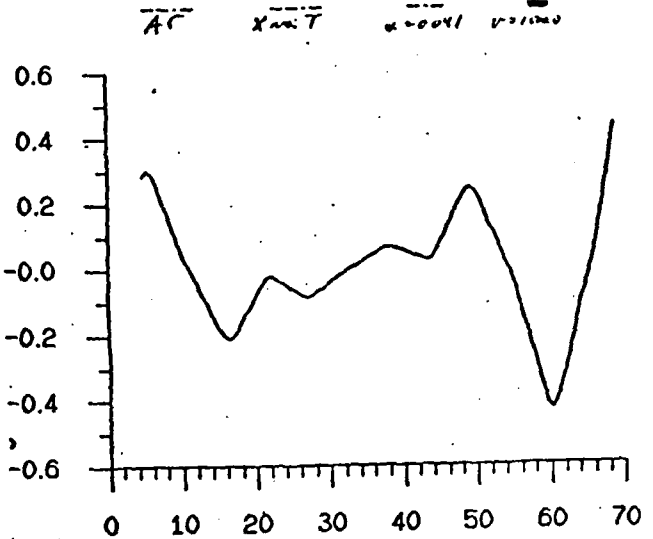
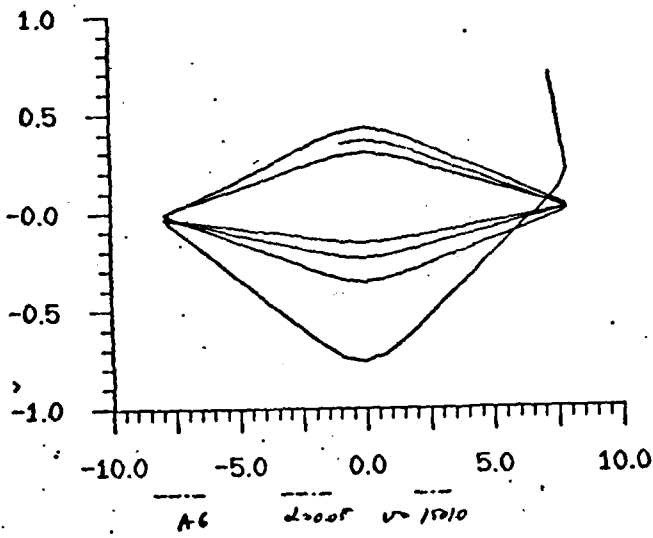
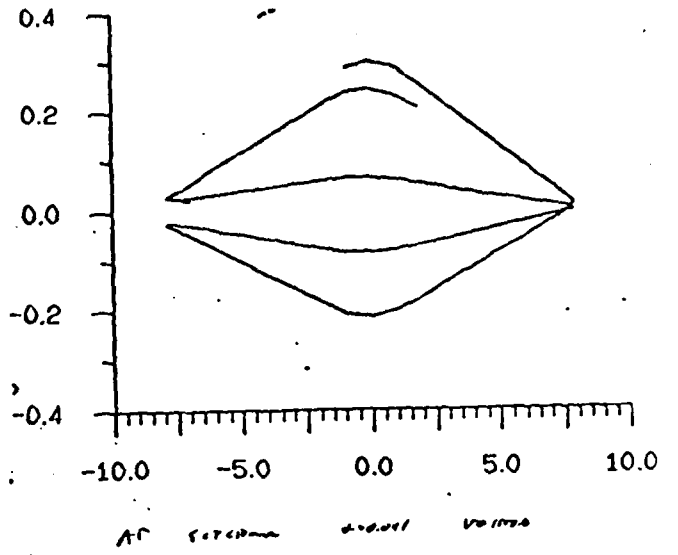
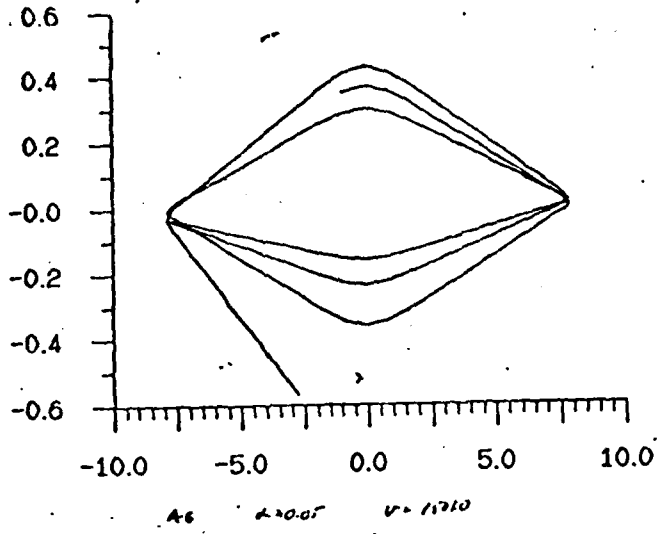

The Spherical Hexapole Trap

The spherical hexapole trap was first described by W. Paul in 1956. It consists of three current loops in parallel planes on the surface of a sphere as shown on the left in the sketch below. In a plane containing the axis of rotational symmetry, placement of the small coils at latitude $+60^\circ$ and -60° results in the well-known hexapole geometry, but not the simple field of a standard hexapole magnet that has straight line conductors. This is a simple consequence of the different geometry.

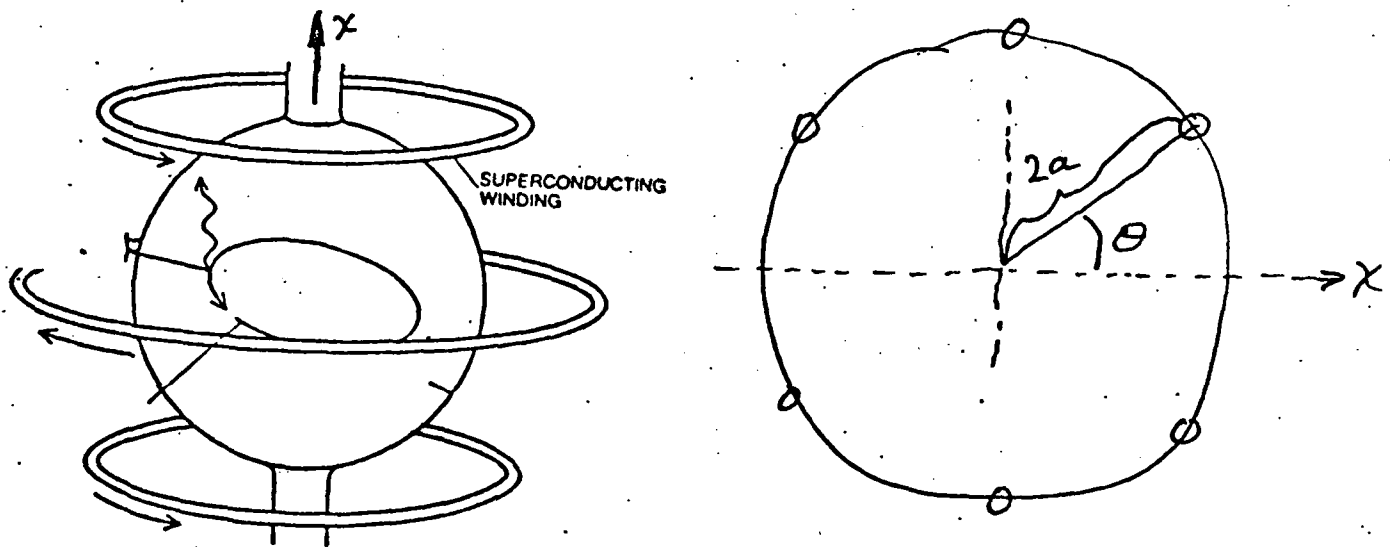

The most obvious difference is in the field along the axis. In a conventional hexapole the field is zero at the geometric center, but for the spherical hexapole with the small loops at $+60^\circ$ and -60° latitude and equal currents in each loop (six-fold symmetry in the axial

plane) it is not zero. In fact, the field along the axis of the three loops can be readily calculated for the geometry shown in the sketch at the right above (taken in a plane containing the axis). The field is

$$B(x, \theta) = 2a^2 \mu_0 I \left[\frac{\sin^2 \theta}{[4a^2 \sin^2 \theta + (2a \cos \theta - x)^2]^{3/2}} + \frac{\sin^2 \theta}{[4a^2 \sin^2 \theta + (2a \cos \theta + x)^2]^{3/2}} - \frac{1}{[4a^2 + x^2]^{3/2}} \right]$$

In order to have the field zero at the center, we need ($x=0$)

$$2 \frac{\sin^2 \theta}{8a^3} - \frac{1}{8a^3} = 0$$

so that $\theta = 45^\circ$. This results in slightly different trapping depths in different directions because the field is no longer that of a symmetric hexapole. Of course, we might want to choose the design so that the field is never exactly zero in order to minimize the rate of Majorana transitions to non-trapping atomic states. Plots of the field along the axis for a few values of θ are shown on the next page.

In order to construct a suitable spherical hexapole trap, we have to do some elementary estimates. First, note that a field of 0.05 T (500 Gauss) is sufficiently strong to stop (i.e., trap) atoms moving at velocity about 5 m/s. Since our post-cooled atoms have a velocity distribution centered at zero, 20 m/s fwhm, more than half of them have velocity of magnitude 5 m/s or less. Therefore 0.05 T is a reasonable design criterion.

9A B (Arbitrary units)

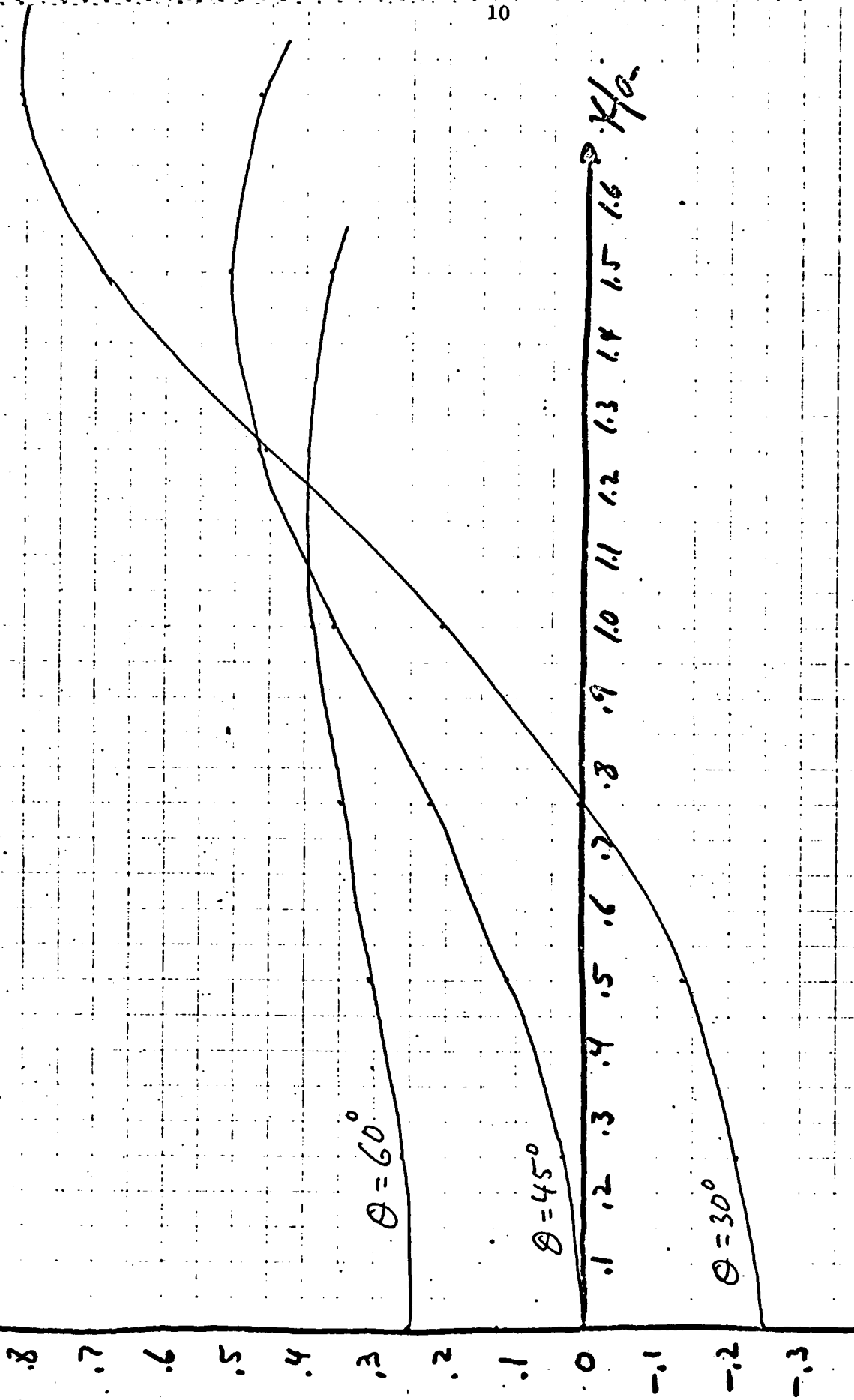

1 1.2 1.3 1.4 1.5 1.6

If we consider a spherical hexapole made of ordinary copper wire (not superconducting), then a primary design parameter is the power dissipation and heat removal in the vacuum. Now consider a trap of linear dimension characterized by a as shown on the previous page. The power required to produce a field B in one of the small, end coils is

$$P_0 = I^2 R = \frac{16 \sqrt{2} \pi a^3 B^2 \rho}{\mu_0^2 A}$$

where A is the cross section area of the coil windings. Since the field at the center of the large center coil is only $1/2\sqrt{2}$ that at the center of the small coil, it requires a power $P_0/\sqrt{2}$ and the total power required for the trap is $P_0(1+1/\sqrt{2}) = 2.7P_0$.

For a reasonable size trap, we take a about 1 cm so that the end coils are about 28 mm diam and the center coil is about 4 cm diam. We choose the coils to be about 5 mm long and 5 mm high ($A=2.5 \times 10^{-5}$). Then the power required is about 200 Watts.

Removal of this amount of power from the vacuum system is unwise but possible. On the other hand, magnet coils operated at liquid nitrogen temperature would dissipate only about one-tenth as much power, and might be much better. The power would evaporate about 0.1 grams of LN2 per second, which produces about 5 L of gas per minute.

This is easily handled by a system similar to the one we presently use to cool the sodium oven baffle plate. Furthermore, the presence of a cold surface in the vacuum chamber will surely help to improve the vacuum. A gate valve will be necessary to shield the trap from the heat generated by the idling titanium pump. A sketch of an appropriate coil form is shown on the next page.

Of course, a suitable trap need not have the geometry discussed above. It is certainly possible to produce a magnetic field configuration with the desired properties using three coils of the same diameter. Such an arrangement might be easier to construct and to cool, but it would not provide as much trapping volume for a given input power.

It is therefore proposed that we construct a spherical hexapole trap. The problem of how to detect trapped atoms is still unsolved, but there are a number of possibilities. The simplest ones are destructive of the trap's population, but using appropriate delays will still allow us to demonstrate and measure the trapping time. The orbit calculating programs written by T. Bergeman at Stony Brook are readily adaptable to the spherical hexapole, and can surely be used.

In all, the spherical hexapole seems like a most attractive path for future work.

Scale 1" on drawing = 1 cm

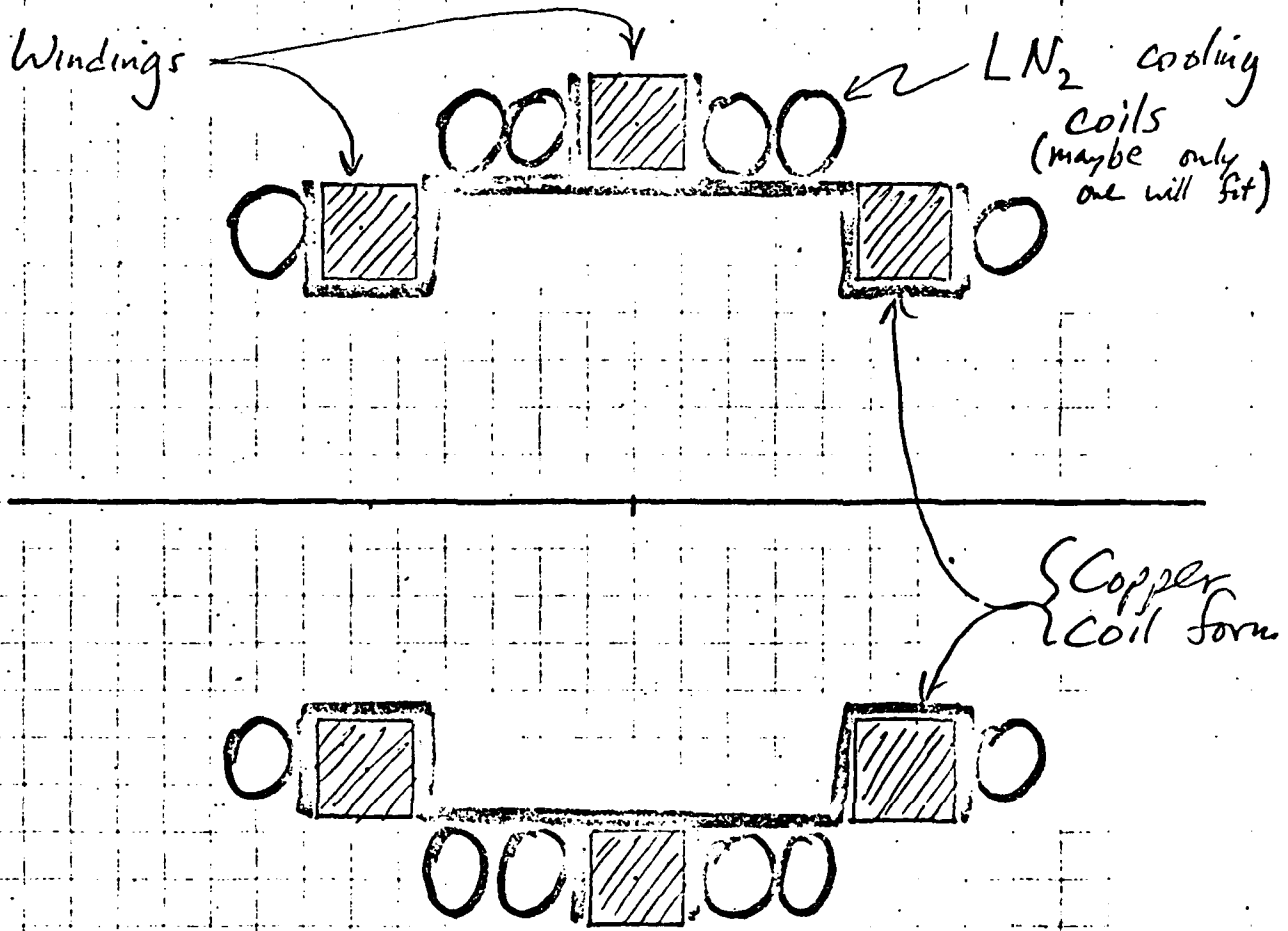

B. COMPUTER MODELLING OF DECELERATION

In section IIB of the original proposal we promised work on computer modelling of the deceleration process. Many different calculations have been carried out, but the most successful one has been a simulation of the experimental process we have called 'post-cooling'. Section E below describes the delayed pulse deceleration we have used in the laboratory at the N.B.S. in order to produce a sample of atoms moving at essentially zero velocity. This process has been modelled in some detail by Ivan So, a student at Stony Brook working under the direction of Harold Metcalf. This section describes that modelling.

In these experiments a short pulse of light is applied to a sample of atoms having a velocity distribution resulting from the ordinary laser deceleration. During the pulse, the velocity distribution is shifted, broadened or narrowed, and distorted. On the next pages are plots of the time evolution of the velocity distribution as calculated by this model.

Although only three plots are shown, this process has been modelled over a wide range of experimental parameters. Plots on page 17 summarize these results. The purpose of these is to show that very small changes in the laser frequency produce significant effects on the evolution of the velocity distribution during the pulse. This points up the need for very stable lasers and careful tuning. Of

course, this is consistent with our experimental observations.

Ivan has made many other calculations, especially in the direction of further cooling. Under some conditions, this short pulse can produce a factor of five or more reduction in the width of the velocity distribution (fact of 25 in temperature!). We are trying to find a domain of parameters where this prediction will be confirmed by experiment, and still be consistent with the known optimum values of laser power, tuning, etc.

TEMPORAL EVOLUTION OF VELOCITY DISTRIBUTION
DURING POST-COOLING PULSE

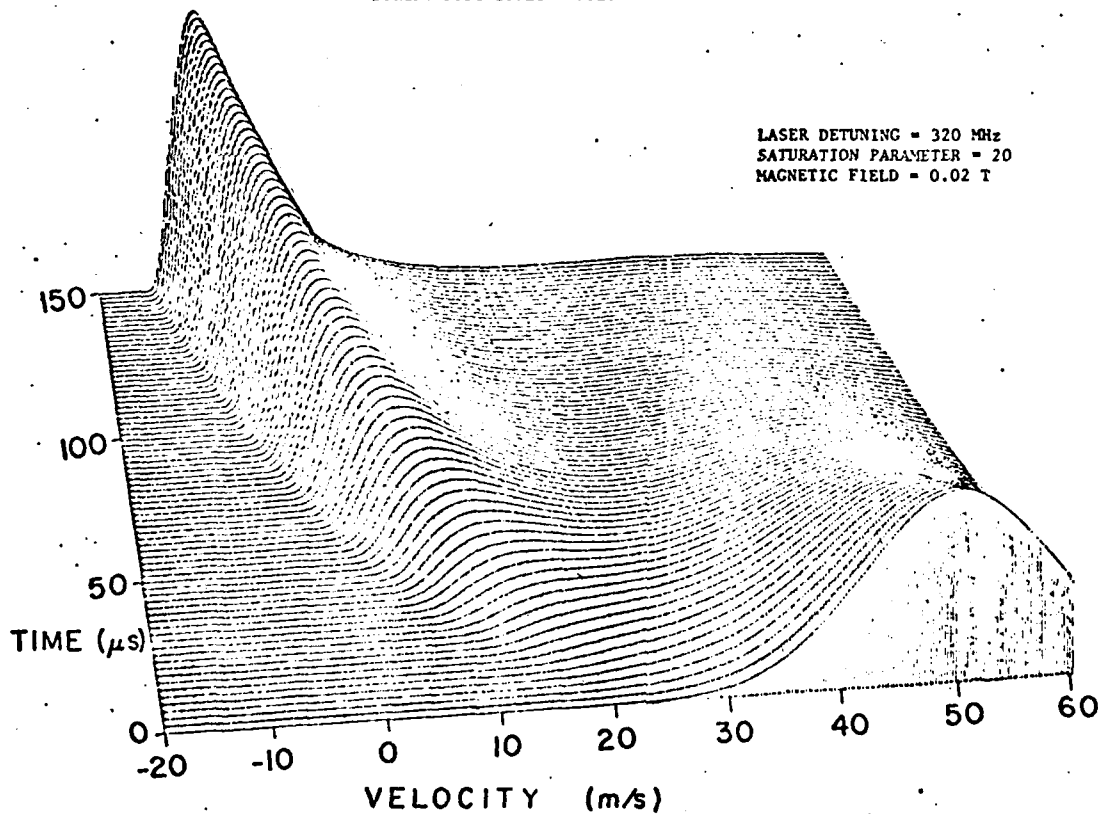

PLOT OF EVOLUTION OF VELOCITY DISTRIBUTION
DURING POST-COOLING

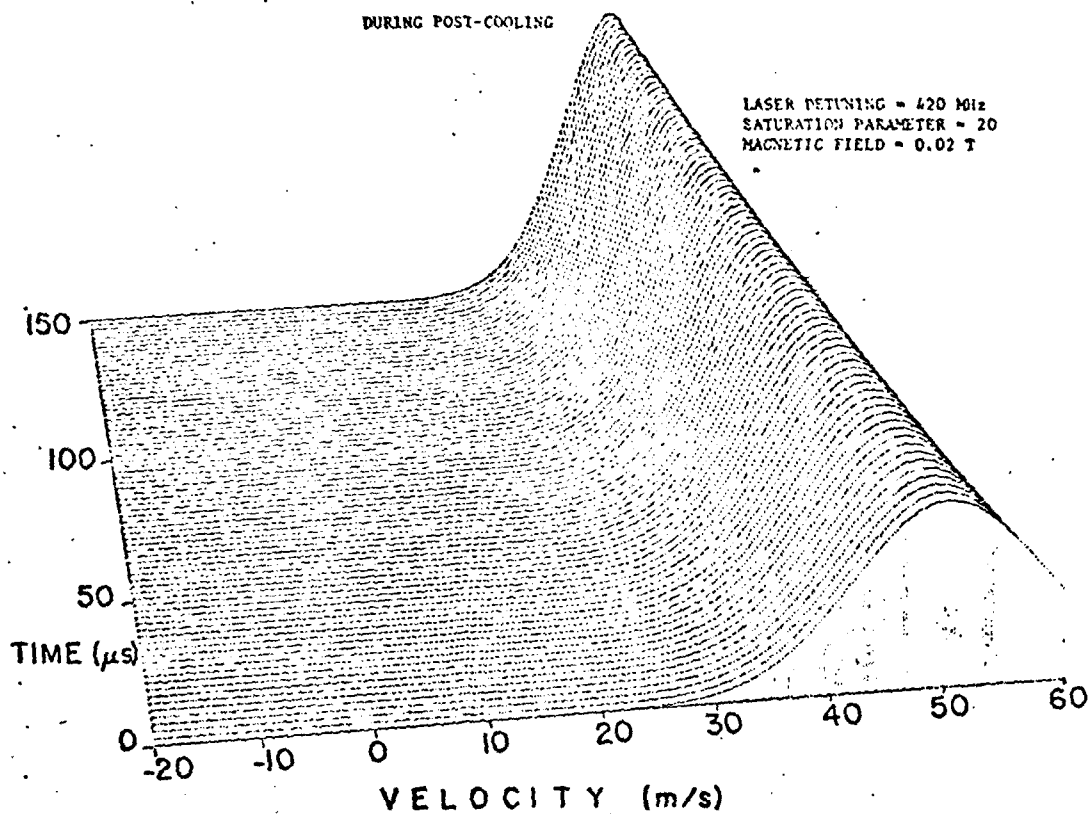

TEMPORAL EVOLUTION OF VELOCITY DISTRIBUTION
DURING POST-COOLING PULSE

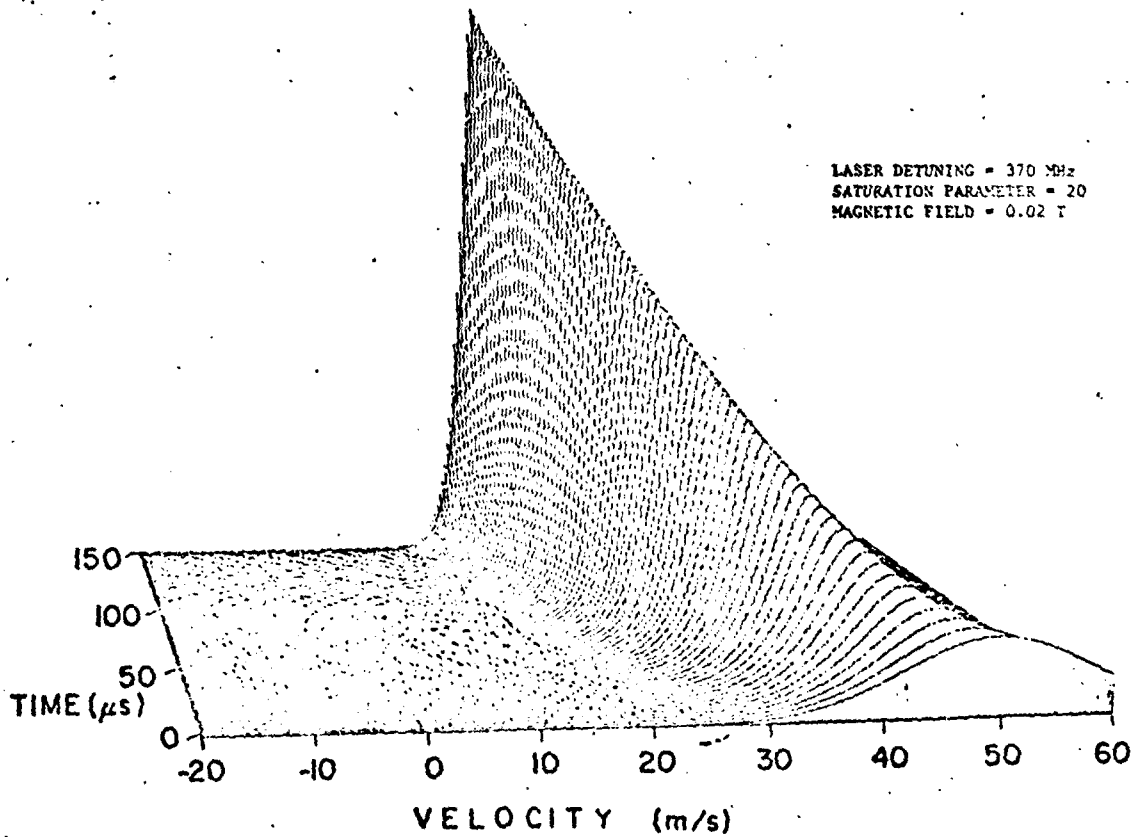

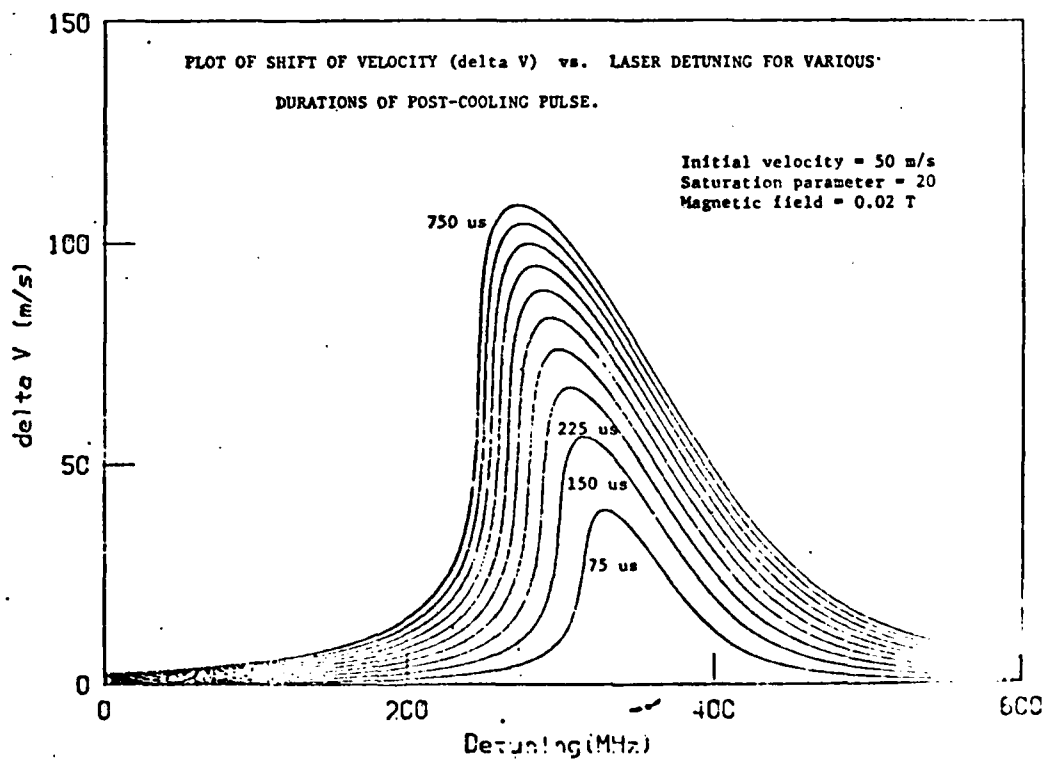
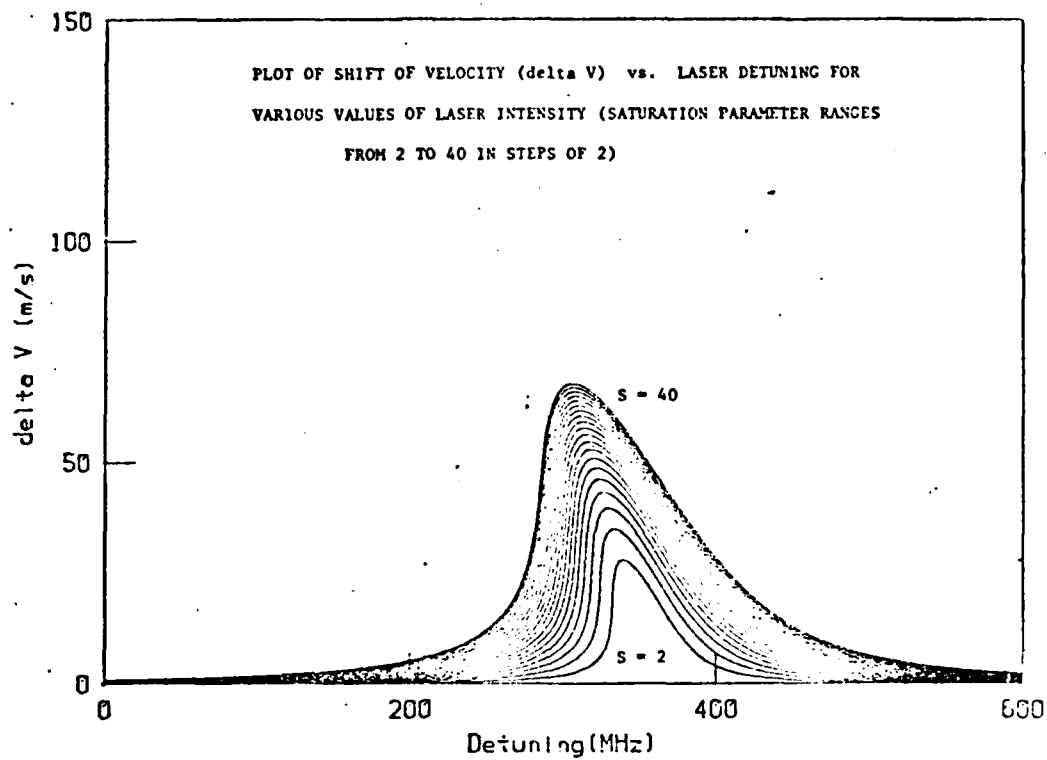

C. FOCUSSING OF SLOW ATOMS

In section IIIA of the original proposal we suggested that a magnetic hexapole lens would be ideal for slow atoms because its severest constraints would be strongly relaxed. Since the focal length varies as velocity squared, our slow atom beam allows a very short focal length (i.e., very large f-number) and therefore very high collecting power. The collecting power of a magnetic hexapole is inversely proportional to the fourth power of velocity. Also, the highly monovelocity character of our laser decelerated atomic beam results in very little spread of the focal focal length (chromatic aberration) of the lens. We have designed, built, installed, and tested the device shown on the right in the diagram below. The electromagnets allow us to vary the focal length as we vary the velocity. It has worked extremely well in the intended design domain. An abstract submitted to the D.E.A.P. meeting in Connecticut is in Appendix A.

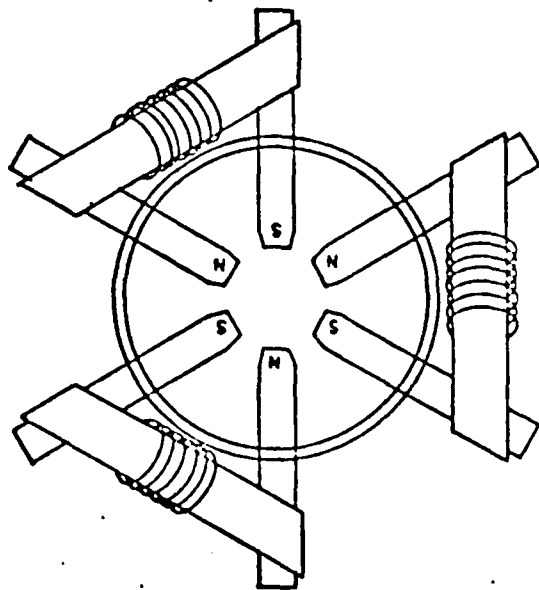
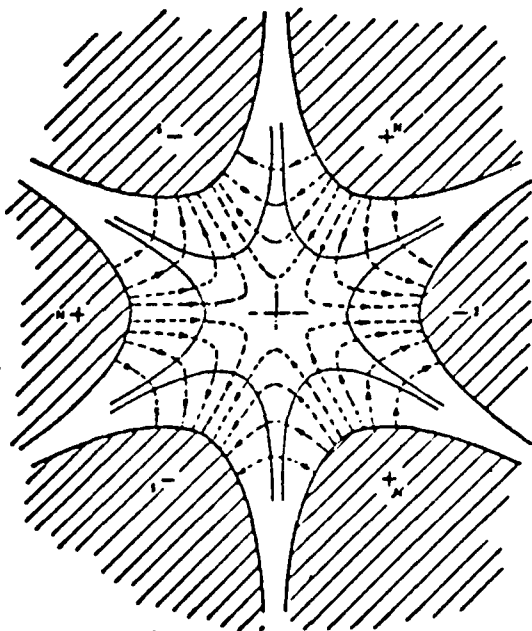

D. FIBER OPTIC VELOCIMETER

We have designed and built a fiber optic device for collecting the data from the scanned analyzing laser. It is very compact and flexible as shown in the (crude) sketch below. The lens and lucite body are arranged for proper index matching and optimal light collection. Total internal reflection at 46° occurs at the angled face. This device has been tested with simulated targets, but has not yet been installed in the atomic beam apparatus.

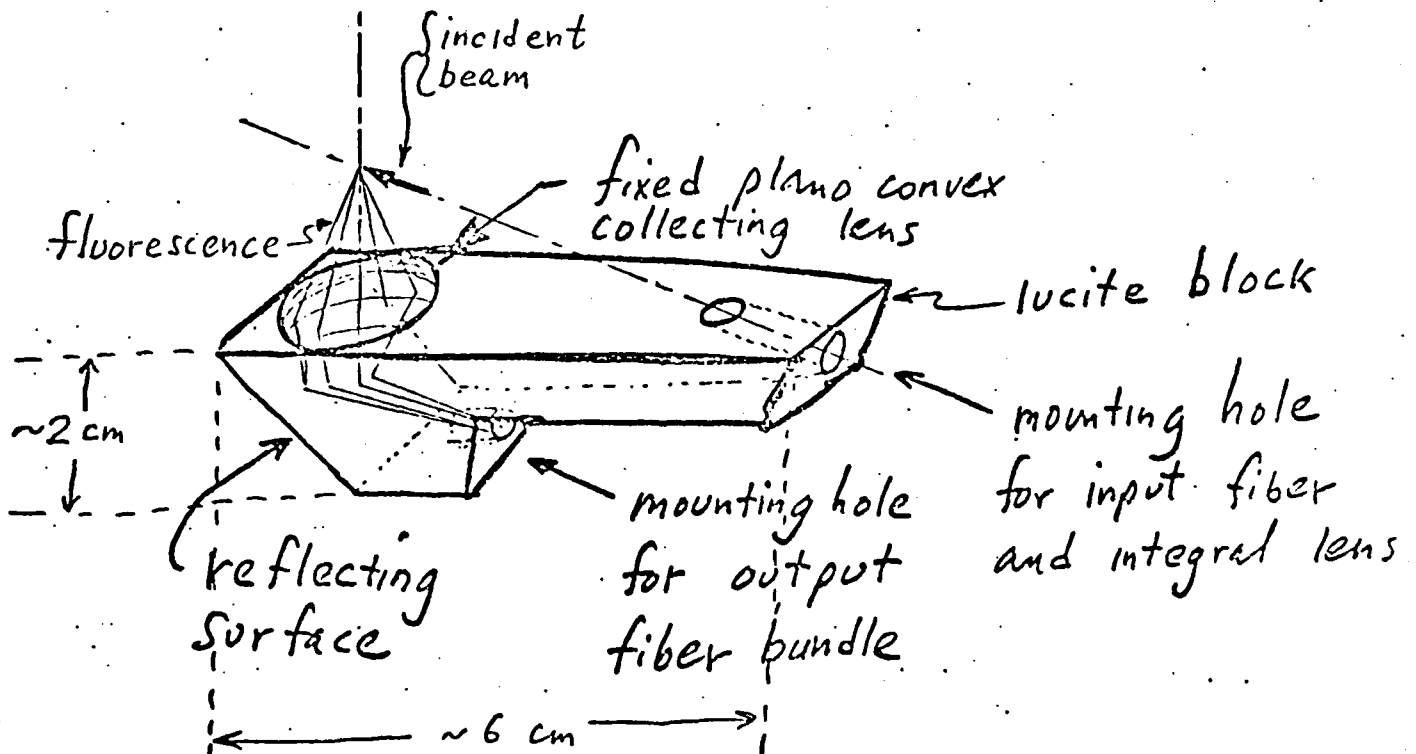

E. DECELERATION OF ATOMS TO ZERO VELOCITY

We have produced a sample of decelerated atoms with a velocity distribution about 20 m/s FWHM centered at zero velocity. This is done by decelerating atoms to about 50 m/s as in our previous experiments, allowing them to drift into the observation region in the dark, and then illuminating them with a short pulse of light from the cooling laser for further deceleration. We applied a short (70 - 250 μ s) pulse of light from the cooling laser, delayed 7 - 9 ms after the main cooling process was terminated by the chopper. In order to do this we added a rim section with a hole to one of the openings in the chopper. We have called this process "post-cooling", but this is really not the best label since cooling does not occur all the time (heating is possible!); it should really be called "second deceleration". In Appendix A are copies of abstracts describing some of our work that have been submitted to meetings of the A.P.S. (Washington), the D.E.A.P. and the workshop on controlling atoms (Connecticut), and the I.C.A.P. (Seattle).

In order to avoid optical pumping, as well as to bring the atoms in the viewing region into resonance with the cooling laser at the time of the short light pulse, we have applied a magnetic field in this region. Two coils of 800 turns of 17 gauge wire are mounted to produce a field parallel to the main cooling field. They are each 4.8 cm long, 21 cm ID, and about 29 cm OD. They are separated by

about 24 cm center-to-center (NOT Helmholtz separation). The current from the main solenoid is passed through these (in series) with the power supply in constant current regulation mode.

We can estimate the velocity change in this process as follows. Consider a power-broadened Lorentzian absorption profile for atoms decelerating under the influence of a counter-propagating laser beam. The laser frequency is chosen to be below resonance for atoms traveling at velocity v . As the atoms scatter light and decelerate, they move into resonance with the laser because of their decreased Doppler shift. As time goes on they decelerate further and are Doppler shifted out of resonance again, but now the laser frequency is above resonance. The deceleration process is swept through the absorption profile, and the average deceleration can be readily calculated by integrating the profile over the relevant frequency range. That range is determined by the duration of the post-cooling pulse and by the power-broadened width of the absorption profile. The result is $\langle a \rangle = (10^6/b) \arctan(b)$ where $b = v/\lambda - \nu_L$ for a frequency range symmetric about zero detuning (this symmetry gives a maximum $\langle a \rangle$). Of course, this is an average over frequency, not over time. Using parameters similar to those of our experiments on March 15 and 16, the maximum velocity change is about 85 m/s, in excellent agreement with our measured value of 80 m/s. Even though this calculation replaces the time-averaged acceleration by its frequency average, and this approximation has limited validity, it is useful for order-of-magnitude

estimates. Of course, if the laser tuning is not correct, and the resulting deceleration does not sweep symmetrically through the very strong center of the absorption profile, the velocity change will be much less.

The first successful experiments using the post-cooling scheme were done in December, 1983, and more definitive results were obtained during January, 1984. We observed atoms decelerated to $v=0$ in a velocity distribution of fwhm about 20 m/s. These atoms could be observed in the observation region long after the end of the post-cooling light pulse (few ms).

Unfortunately there were some ambiguities in interpretation of the data that arose primarily from the frequency drift of the cooling laser between runs and from the accuracy of our perpendicular markers in determining the point of zero Doppler shift. Although a careful analysis of these problems did not show any significant sources of error, we decided to eliminate them by a number of changes. The perpendicular markers were replaced by a saturated-absorption arrangement which allows Doppler-free detection of the Na resonances. The spectrum analyzers were mounted in a thermally stabilized enclosure to reduce their drifts. The signals from the 300 MHz spectrum analyzer, the saturated absorption cell, and the beat frequency diode were combined in a summing network and fed to the second channel of the recorder. All of this work resulted in a continuous and nearly simultaneous record of the system parameters along with data.

In March we used this excellent system to do more post-cooling experiments, with much more well-defined results. For every run we can determine the cooling laser frequency, monitor the analyzing laser, and determine the point of zero Doppler shift with much less uncertainty. The data of March 15 and 16 have been analyzed in some detail. Since most of the signals appear on a sloping baseline, some well-known properties of Lorentz lineshapes were used to extract centers and widths from the data. On page 25 is a rough plot that shows the dependence of the atomic velocity on cooling laser frequency, both with and without the magnetic field in the viewing (post-cooling) region. It also shows the change in velocity produced by the post-cooling pulse. The vertical bars (and numbers) show the width of the velocity distribution. All of these quantities are given in units of mm on the chart paper, and the proper calibration is provided. On page 26 is a comparison of the measured velocity change with the values calculated from the model made by Ivan So. Finally (p. 27) there is a copy of a typical set of data.

It is clear that we can decelerate atoms to $v = 0$, and even reverse their direction. We can do this without a substantial increase in the width of the velocity distribution. In fact, as the model calculations described in part B show, there is a region of velocity change where the width of the distribution is increased (heating), and then further velocity change results in a subsequent decrease of the width (cooling). The quantitative agreement with the model is only approximate, but the qualitative features agree very well.

One qualitative feature that does NOT agree is that further tuning of the cooling laser to the red, beyond that of the frequency that produces the decrease in the velocity spread results in heating. Although this is still a mystery, our current best guess is that the field inhomogeneity of the post-cooling magnetic field is responsible. It allows atoms at other velocities to absorb post-cooling light.

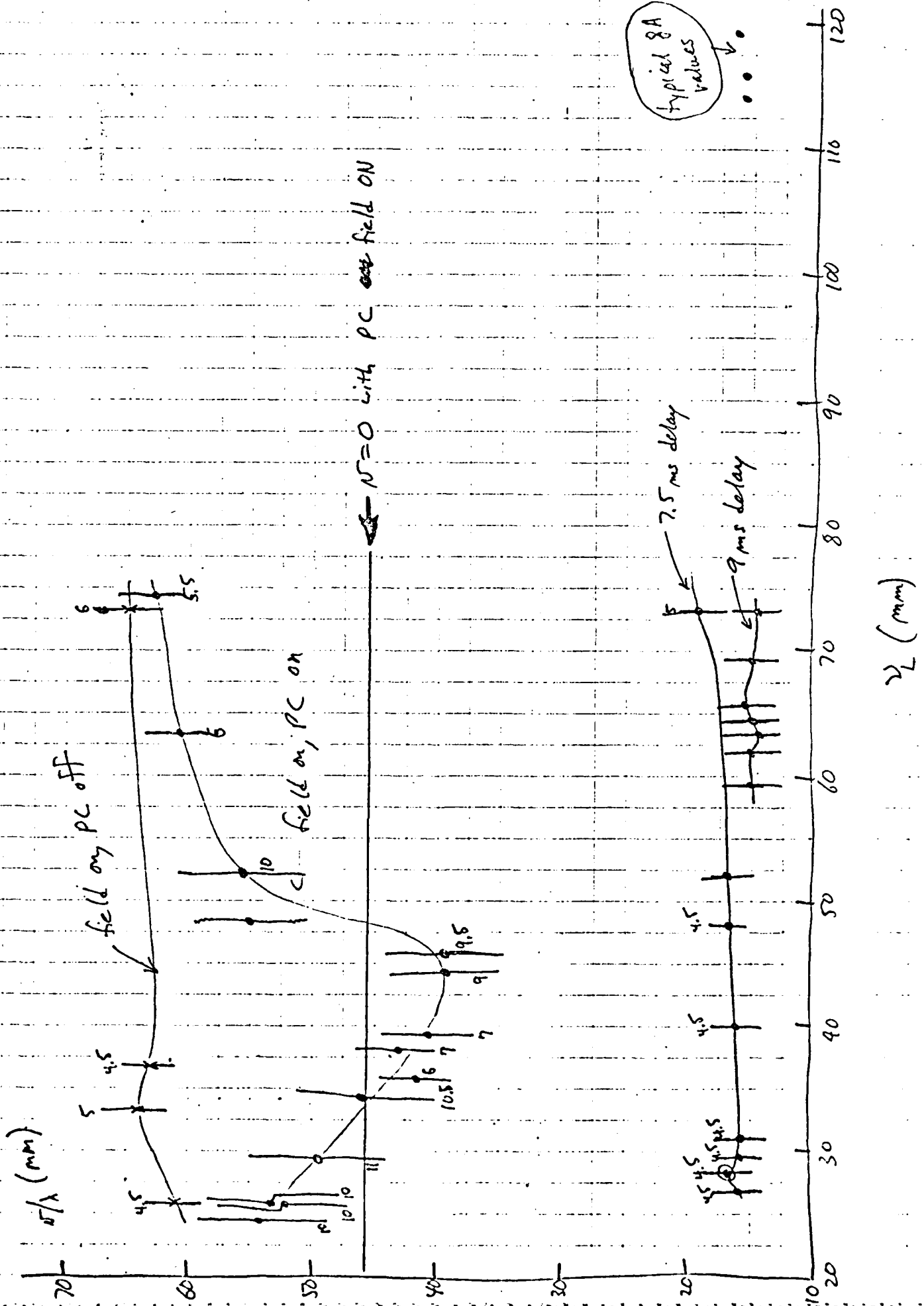

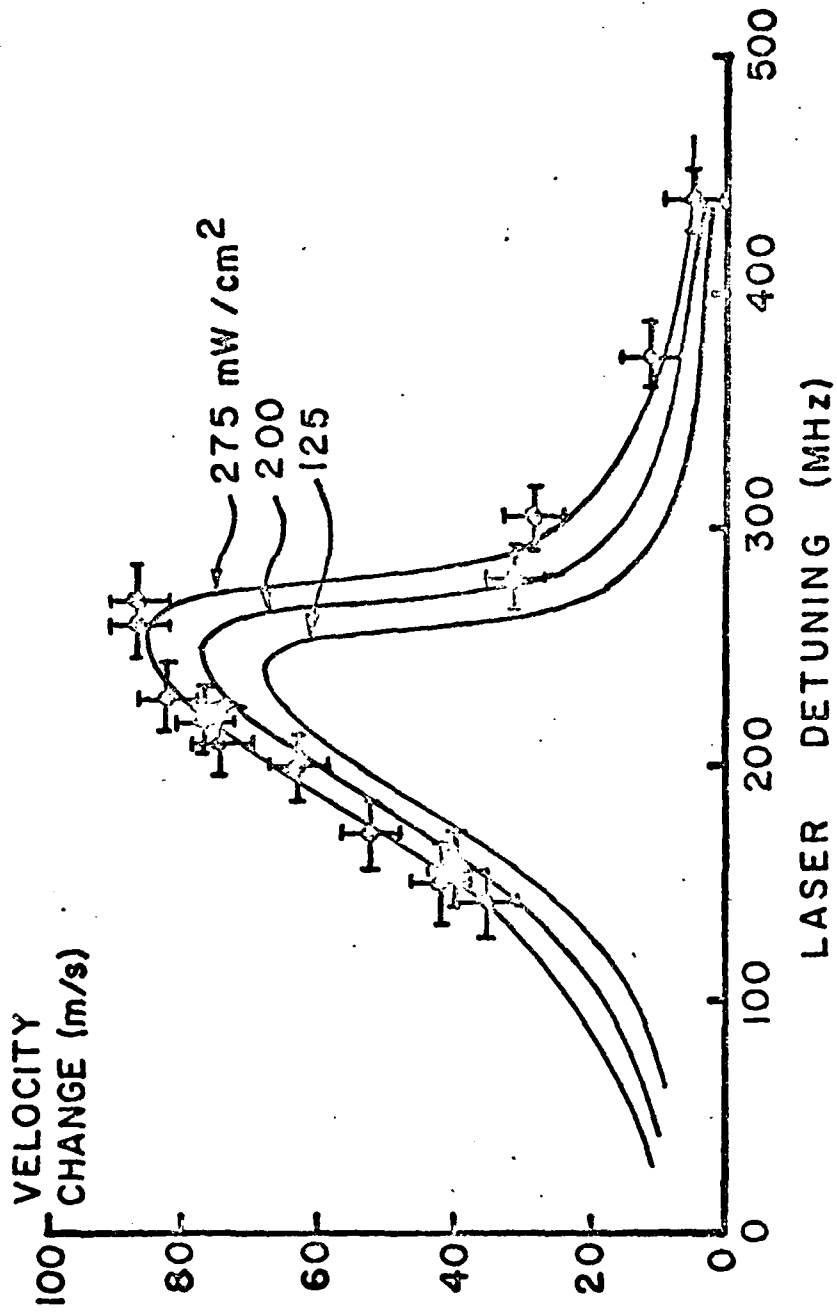

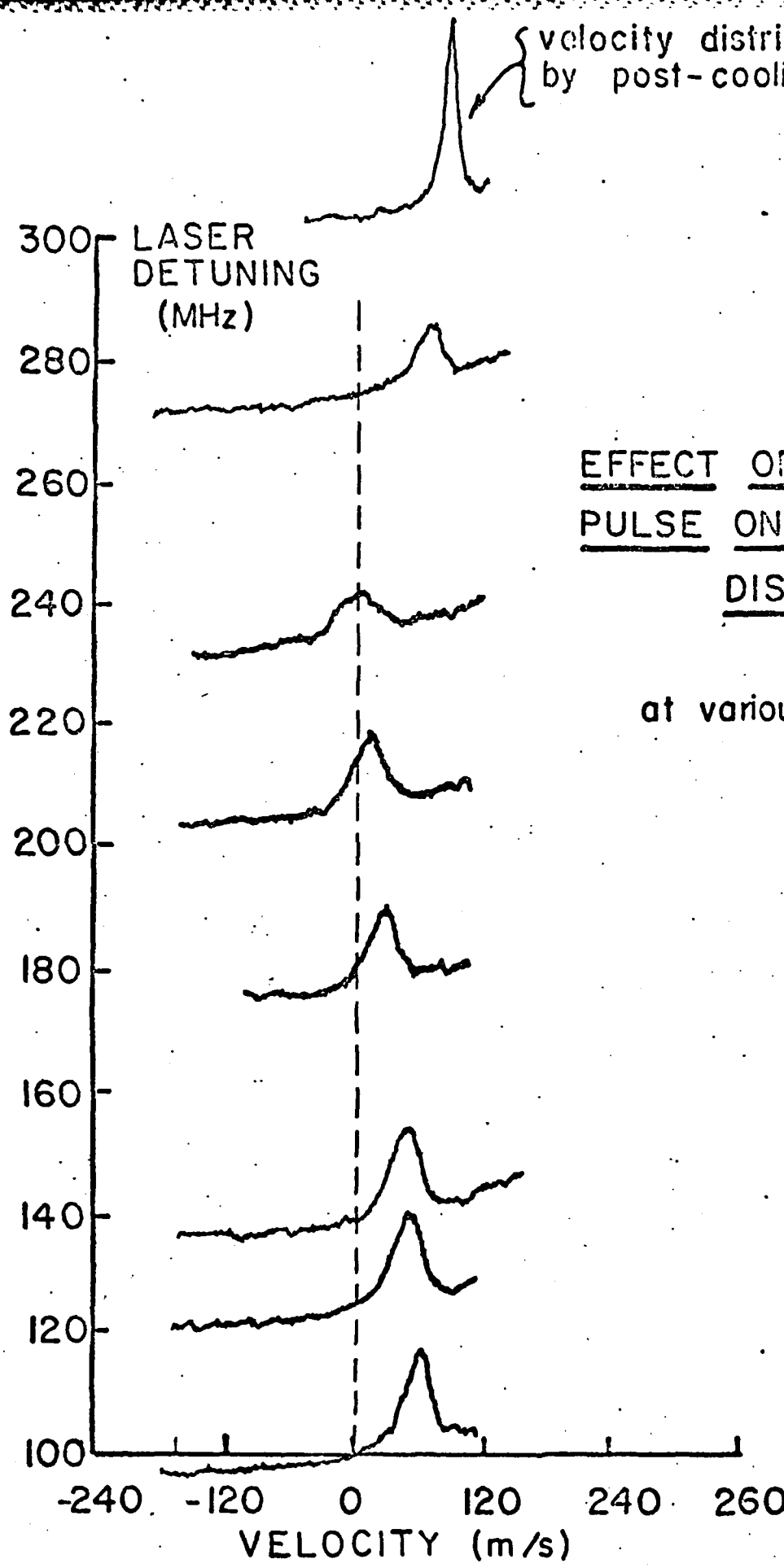

Abstract Submitted
for the Washington Meeting of the
American Physical Society

23 - 26 April, 1984
Date

Physical Review
Analytic Subject Index
Number 32.80.-t

Bulletin Subject Heading
in which Paper should be placed
Cooling and Trapping

Magnetic Trapping of Neutral Atoms, * T. Bergeman and H.J. Metcalf, S.U.N.Y., Stony Brook, N.Y. 11794 -- A scheme is proposed for trapping neutral atoms having magnetic moments μ using inhomogeneous magnetostatic fields.¹ These relatively weak magnetic forces are especially effective on slow atoms because of the long times they spend in the field gradients. Longitudinal confinement in the cylindrically symmetric trap is produced by magnetic mirrors, and transverse confinement by a hexapole lens. Adiabatic precession of μ along the orbital path in the trap is required to maintain alignment of μ with the field. Even though such a configuration has leakage routes (it is not a "bottle"), trajectory calculations indicate that over an appreciable range of initial parameters, there are orbits that remain bound in the trap for longer than .5 sec., perhaps several sec. (in the absence of collisions). This trap is ideally suited for the 10 m/s atomic beam at the N.B.S.²

Supported by the N.S.F. and O.N.R.

1. H. Metcalf in N.B.S. spec. pub. 653, ed. by W. Phillips
2. J.V. Prodan, W.D. Phillips, and H. Metcalf, Phys. Rev. Lett. 49, 1149 (1982); abstract submitted to I.Q.E.C., 1984.

- (x) Prefer Poster Session
() Prefer Standard Session
() No Preference

Submitted by

Harold Metcalf
Signature of APS Member

Harold J. Metcalf
Same name typewritten

Physics Department
Address

S.U.N.Y. Stony Brook, N.Y. 11794

Abstract Submitted

for the D.E.A.P. Meeting of the
American Physical Society

30 May - 1 June, 1984
Date

Physical Review
Analytic Subject Index
Number 32.80.-t

Bulletin Subject Heading
in which Paper should be placed
Cooling and Trapping

Magnetic Trapping of Neutral Atoms,* T. Bergeman and H.J. Metcalf, S.U.N.Y., Stony Brook, N.Y. 11794 -- A scheme is proposed for trapping neutral atoms having magnetic moments μ using inhomogeneous magnetostatic fields.¹ These relatively weak magnetic forces are especially effective on slow atoms because of the long times they spend in the field gradients. Longitudinal confinement in the cylindrically symmetric trap is produced by magnetic mirrors, and transverse confinement by a hexapole lens. Adiabatic precession of μ along the orbital path in the trap is required to maintain alignment of μ with the field. Majorana transitions in the low field region are also described. Lens and mirror aberrations from fringing fields are studied for orbital perturbations. The special advantages of magnetic traps over optical traps will be discussed. The trap is ideally suited for the 10 m/s atomic beam at the N.B.S.²

*Supported by the N.S.F. and O.N.R.

1. H. Metcalf in N.B.S. spec. pub. 653, ed. by W. Phillips

2. J.V. Prodan, W.D. Phillips, and H. Metcalf, Phys. Rev. Lett. 49, 1149 (1982); abstract submitted to I.Q.E.C., 1984.

- (x) Prefer Poster Session
() Prefer Standard Session
() No Preference

Submitted by

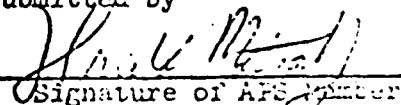
Signature of APS member

Harold J. Metcalf

Same name typewritten
Physics Department

Address S.U.N.Y.

Stony Brook, N.Y. 11794

MAGNETIC TRAPPING OF NEUTRAL ATOMS *

TOM BERGEMAN AND HAROLD METCALF

State University of New York
Stony Brook, New York, 11794, U.S.A.

In this paper we describe ideas for trapping of neutral atoms having finite magnetic moments using magnetostatic fields [1,2]. Since neutral atoms cannot be confined by forces from the interaction of a monopole with a simple potential, traps for them must exploit the interaction between an atomic dipole moment and an inhomogeneous electromagnetic field. Furthermore, unperturbed atoms do not have electric dipole moments because of their inversion symmetry, so electric traps require induced dipole moments produced by mixing states of opposite symmetry. (This may be done efficiently with nearly resonant optical frequency fields or with electrostatic fields.) By contrast, unperturbed atoms may have ground state magnetic dipole moments and these can serve to mediate the trapping force without ancillary production.

In order to confine any particle it is necessary to exchange kinetic for potential energy, and in dipole traps the potential energy must be stored in internal atomic degrees of freedom. The immediate consequence of this requirement is that the atomic energy levels will shift with position in the trap, and that these shifts will affect precision spectroscopic measurements, perhaps severely.

A number of schemes for magnetic trapping of neutrals have been proposed, and free neutrons have already been successfully trapped [3]. Although no traps for neutral atoms have yet been demonstrated, we have been studying a variety of magnetostatic possibilities. The topics of study are the design of such traps, methods of loading them, the nature of the orbits of the trapped atoms, the trapping time, their stability, and methods of detecting atoms in them.

Although magnetostatic traps are rather shallow compared with the kinetic energy reported previously for laser decelerated atoms [4], new techniques have been developed to make slower (but not necessarily colder) atomic samples [5]. Clearly it is now possible to decelerate atoms to $v = 0$, and even reverse their direction. Since the final deceleration step [4] can readily be done inside certain kinds of magnetic traps, preparation of an appropriate atomic sample and loading it into a particular class of magnetic traps is essentially a solved problem.

In one kind of magnetic trap [1], the atoms are confined along the z -axis by reflection between two magnetic mirrors composed of regions of sharply increasing fields (e.g., near the ends of a small solenoid). A magnetic hexapole lens [6] centered between the mirrors deflects diverging atoms back toward the z axis, but is not strong enough for absolute confinement. The trap therefore has dynamic but not absolute stability [2]. From detailed studies of orbits in this trap, we find that over a very small range of parameters, the atom may complete up to five orbits (about 1/10 second) before escaping. The lack of long term stability derives from the curvature of the surface of the magnetic "mirrors" at the ends.

Another type of trap is the spherical hexapole trap first described by W. Paul [7]. It consists of three current loops in parallel planes

on the surface of a sphere as shown in the sketch. If the small coils are placed at latitudes $+30^\circ$ and -30° the well-known hexapole geometry results, but as a consequence of the curved wires it does not have the quadratic and symmetric field of a standard hexapole magnet. The most obvious difference is that the field along the axis does NOT become zero at the center, but IS zero at points away from the center and off the axis. (The field at the center of a spherical hexapole can be made zero with the small coils at 45° latitudes.)

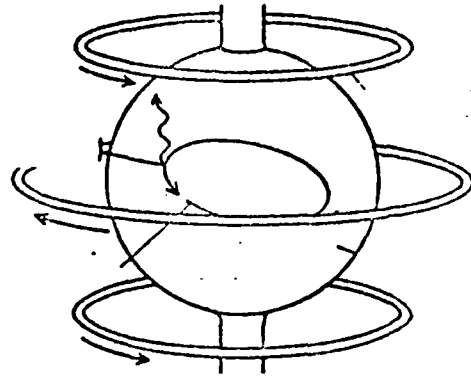

Suitable traps are certainly not restricted to the spherical hexapole geometry. We have calculated the field distribution from three coils centered on the z-axis, symmetric about the x-y plane, having arbitrary diameters, currents, and positions. We find, for example, that approximately equal coil radii gives the deepest trap, but the minimum field does not occur at the trap's center.

Another important question under consideration is the possibility of Majorana transitions to non-trapping atomic states. These are most probable as the atom traverses a region of low field. They can only happen if the field change seen by the atom, dB/dt , is not parallel to B so that the selection rules for a spin flip are satisfied. We are studying orbital paths to analyze various cases. The use of constant background field would eliminate problem but would compromise other trapping parameters.

REFERENCES

* Supported by the N.S.F. and the O.N.R.

1. H. Metcalf, Laser Cooled and Trapped Atoms, N.B.S. Special Publication 653(1983), p. 59.
2. H.Metcalf and T.Bergeman, Bull. Am. Phys. Soc., 29, 686(1984); *ibid.*, 795(1984).
3. K. Kugler, W. Paul, and U. Trinks, Phys. Lett., 72B, 422(1978).
4. W. Phillips and H. Metcalf, Phys.Rev. Lett., 48, 596(1982); J. Prodan, W. Phillips, and H. Metcalf, Phys. Rev. Lett., 49, 1149(1982).
5. J. Prodan et. al., Bull. Am. Phys. Soc., 29, 822(1984).
6. Such a lens is ideally suited for laser decelerated atoms because they are very slow and because their velocity distribution is very narrow. H. Metcalf et.al., Bull. Am. Phys. Soc., 29, 795(1984).
7. N.Niehuys, Thesis, Univ. Bonn Physikalisches Institut.

PACS
number;
32.80-t

Abstract Submitted
for the DEAP Meeting of the
American Physical Society
30 May - 1 June 1984

Suggested Session
Title: Cooling of
Neutral Atoms

Focussing of Slow Atomic Beams*, H. Metcalf**,
W. Phillips and J. Prodan, National Bureau of
Standards, Washington DC 20234--we have made con-
siderable advances in laser deceleration and cooling
of neutral atoms. Because the observed density of
slow atoms in our experiments¹ decreases very rapidly
with velocity, it would be useful to concentrate the
decelerated atomic beam. A magnetic hexapole lens
is ideally suited for this because the velocity distri-
bution of our atomic beam is narrow and centered at
low speeds. We have installed such a lens in our
apparatus and found that atoms in a 30 to 100 m/s
velocity range are concentrated by a factor of five to
ten by the focussing. This has enabled observation
of much slower atoms with better S/N than was previously
obtainable¹. Because the lens' focal length F is
proportional to v^2 , we can use a relatively small mag-
netic field and large aperture. This field is produced
by electromagnets to allow variation of F in order to
optimize atom collection as we vary the speed of our
decelerated atoms.

*Work supported in part by the Office of Naval Research

**Permanent address: S.U.N.Y, Stony Brook, NY

¹J. V. Prodan et al., Phys. Rev. Lett. 49, 1149 (1983)

- (x) Prefer Poster Session
() Prefer Standard Session
() No Preference

Signature of Member
William D. Phillips
Bldg. 220, B253
National Bureau of Standards
Washington DC 20234

PACS
number:
32.80-t

Abstract Submitted for the
Spring Meeting of the American
Physical Society
23-26 April 1984

Suggested session to:
Atomic Spectroscopy

Deceleration of Atoms to Zero Velocity,*

J. Prodan, W. Phillips, J. Dalibard† and H. Metcalf**,
National Bureau of Standards, Washington DC 20234--

We have produced a sample of atoms whose velocity distribution has a FWHM of about 20 m/s and is centered at $v = 0$ m/s. This represents considerable improvement over our previous results.¹ We applied a short (70 - 250 μ s) pulse of light, from the cooling laser, delayed 9 ms after the main cooling process was terminated by a mechanical chopper in the laser beam (see Ref. 1). This allowed atoms to drift in the dark from the tapered solenoid to the observation region, 40 cm away, before being irradiated by this short pulse. We found the original distribution with FWHM of about 15 m/s, centered near 45 m/s, was decelerated and broadened and that the atoms were brought to rest. Atoms seemed to be drifting out of the observation region in a time (a few milliseconds) consistent with the region's geometry and the width of the velocity distribution.

*Work supported in part by the Office of Naval Research

†Permanent address: Ecole Normale Supérieure, Paris, Fr.

**Permanent address: S.U.N.Y., Stony Brook, NY

¹J. V. Prodan et al., Phys. Rev. Lett. 49, 1149 (1983)

(x) Prefer poster Session

Signature of APS Member
William D. Phillips
Bldg. 220, 3256
National Bureau of Standards
Washington, DC 20234

PACS
number:
32.80-t

Abstract Submitted
for the DEAP Meeting for the
American Physical Society
30 May - 1 June 1984

Suggested Session
Title: Cooling of
Neutral Atoms

Deceleration of Atoms to Zero Velocity,*

J. Prodan, W. Phillips, J. Dalibard† and H. Metcalf**,
National Bureau of Standards, Washington DC 20234--

We have produced a sample of atoms whose velocity distribution has a FWHM of about 20 m/s and is centered at $v = 0$ m/s. This represents considerable improvement over our previous results.¹ We applied a short (70 - 250 μ s) pulse of light, from the cooling laser, delayed 9 ms after the main cooling process was terminated by a mechanical chopper in the laser beam (see Ref. 1).

This allowed atoms to drift in the dark from the tapered solenoid to the observation region, 40 cm away, before being irradiated by this short pulse. We found the original distribution with FWHM of about 15 m/s, centered near 45 m/s, was decelerated and broadened and that the atoms were brought to rest. Atoms seemed to be drifting out of the observation region in a time (a few milliseconds) consistent with the region's geometry and the width of the velocity distribution.

*Work supported in part by the Office of Naval Research

†Permanent address: Ecole Normale Supérieure, Paris, Fr.

**Permanent address: S.U.N.Y., Stony Brook, NY

¹J. V. Prodan et al., Phys. Rev. Lett. 49, 1149 (1983)

- Prefer Poster Session
 Prefer Standard Session
 No Preference

Signature of APS Member
William D. Phillips
Bldg. 220, B258
National Bureau of Standards
Washington, DC 20234

LASER COOLING OF ATOMIC BEAMS

W. D. Phillips and J. V. Prodan
Electricity Division, National Bureau of Standards
Washington, DC 20234

H. J. Metcalf
Department of Physics, State University of New York
Stony Brook, NY 11794

and

J. Dalibard
Laboratoire de Spectroscopie Hertzienne, Ecole Normale Supérieure
24 Rue Lhomond, F 75231 Paris Cedex 05, France

Our earlier work on laser deceleration and cooling of an atomic sodium beam has been described extensively in the literature [1-6]. This abstract will briefly review some of that work and describe the most recent work in our laboratory. In particular, we report the observation of zero velocity atoms, the magnetic focussing of very slow atoms and some of our plans for the future.

Most of our laser cooling work has used a spatially varying magnetic field to provide a varying Zeeman shift which cancels the varying Doppler shift of the decelerating atoms. In this case, the cooling laser is kept at a fixed frequency, which together with the magnetic field determines the maximum velocity atoms which can be cooled, and the final velocity achieved.

For some laser frequencies, atoms reach the end of the tapered solenoid (which produces the spatially varying field) with a velocity so high that their changing Doppler shift is unable to match the rapidly changing Zeeman shift as they exit the solenoid. The atoms go out of resonance with the laser and emerge from the solenoid as a continuous beam with a narrow velocity distribution whose shape is dependent on the details of the field shape. This beam is observed 40 cm from the magnet, where the magnetic field is nearly zero. The smallest velocity observed in this way is 200 m/s.

For other laser frequencies the velocity of the atoms is never high enough for them to go out of resonance with the cooling laser and they are stopped near the end of the solenoid, never reaching the observation region. In order for very slow atoms to be observed, the cooling laser is shut off and slow atoms drift in the dark into the observation region, where they are detected. Atoms at least as slow as 30 m/s have been observed by this technique.

Recently we have used an additional pulse of cooling laser light to further slow, stop, and even turn around the very slow atoms in the observation region. We call this process "post-cooling". The laser tuning is adjusted so that atoms are brought to rest near the exit end of the solenoid. The cooling laser is shut off, and during the approximately 10 ms of darkness the atoms drift from the solenoid to the observation region. Those atoms with the correct velocity (about 40 m/s) to arrive in the observation region after 10 ms are there irradiated a second time with a 40-250 us pulse from the cooling laser. When the cooling laser is switched off the second time, the velocity distribution is observed following a delay ranging from 50 us to several milliseconds.

To avoid optical pumping in the post-cooling phase, a magnetic field is applied at the observation region. The field also allows the same fixed cooling laser frequency which accomplished the initial cooling in the solenoid to be resonant with the slow atoms in the observation region. Post-cooling pulse lengths of 80-100 us are required to bring atoms to rest, while the longer pulses nearly reverse the velocity. This implies that even faster initial velocities could be stopped.

One of the difficulties with our earlier work [2] was the sharp decrease in observed atom density as longer delays were used to observe slower atoms. The decrease is presumably attributable to spreading of the atomic beam as the longitudinal velocity, but not the transverse, is reduced. While we do not have a quantitatively accurate model for this decrease, we have taken steps to reduce it by using a hexapole focussing magnet. The design of the magnet is discussed elsewhere [7], and consists of six iron rods extending radially from a gap approximately 2 cm in diameter. The hexapole is operated as an electromagnet so that its focal length can be varied. Using this lens, the density of slow atoms of a given velocity has been enhanced by a factor of five to ten over what is obtained without the lens.

One of our objectives is to use these recently developed techniques to realize a laser trap for sodium atoms. Slow atoms with velocities of perhaps 40-80 m/s would be focussed into a separately pumped high vacuum chamber where they would be stopped by a post cooling pulse. A laser trap, designed along the lines suggested by Dalibard, Reynaud and Cohen-tannoudji [8] would capture the slowest atoms in the post-cooled velocity distribution. Depending on the exact trap size and depth, we would expect on the order of one trappable atom to be in the trap volume after the post-cooling pulse, and several more to drift in within a few milliseconds after.

The reader is referred to our abstracts for the current DEAP meeting for additional information concerning the recent experimental developments.

This work was supported in part by the Office of Naval Research.

- 11) W. D. Phillips and H. J. Metcalf, *Phys. Rev. Lett.* 48, 596 (1982).
- 12) J. V. Prodan, W. D. Phillips and H. J. Metcalf, *Phys. Rev. Lett.*, 49, 1149 (1982).
- 13) W. D. Phillips, J. V. Prodan and H. J. Metcalf in *Laser-Cooled and Trapped Atoms*, Ed. by W. D. Phillips, *Natl. Bur. Stand. (U.S.) Spec. Publ. 653* (1983) p. 1.
- 14) J. V. Prodan and W. D. Phillips in *Laser-Cooled and Trapped Atoms*, Ed. by W. D. Phillips, *Natl. Bur. Stand. (U.S.) Spec. Publ. 653* (1983) p. 137.
- 15) W. D. Phillips and J. V. Prodan in *Proceedings of the fifth Rochester Conference on Coherence and Quantum Optics*, to be published.
- 16) W. D. Phillips, J. V. Prodan and H. J. Metcalf in *Laser Spectroscopy VI*, Ed. by H. P. Weber and W. Luthy (Springer, Berlin, 1983) p. 162.
- 17) H. J. Metcalf in *Laser-Cooled and Trapped Atoms*, Ed. by W. D. Phillips, *Natl. Bur. Stand. Spec. Publ. 653* (1983) p. 59.
- 18) J. Dalibard, S. Reynaud and C. Cohen-Tannoudji, *Opt. Commun.* 47, 395 (1983).

DECELERATION OF ATOMS TO ZERO VELOCITY *

J. PRODAN, IVAN SO +, W. PHILLIPS, and H. METCALF +

National Bureau of Standards
Washington D.C. 20234

Laser cooling, the deceleration and compression of the velocity distribution of free atoms, is used to produce a dense sample of slowly moving atoms. In our experiments [1], atoms in an atomic beam are cooled by directing a near resonant laser beam opposite to their motion. The atoms absorb and then fluoresce the light, changing their velocity by $h\nu/Mc$ each time. The maximum attainable acceleration at high light intensities is limited to $h\nu/2Mc\tau$; for Na this is about 10^6 m/s^2 . It takes about 33,000 scattering events during at least 1 ms to decelerate thermal Na atoms ($v = 1000 \text{ m/s}$) to rest along a beam at least 0.5 m long.

As the atoms in the beam scatter light and slow down, their changing Doppler shift takes them out of resonance with the laser and they eventually cease deceleration. We have overcome this problem [1] by using a spatially varying magnetic field produced by a non-uniform solenoid to Zeeman tune the atomic levels along the beam path. For uniform deceleration, the proper tuning is achieved by a field given by $B = B_0\sqrt{1 - 2az/v^2}$ where a is the deceleration.

Some atoms in a thermal velocity distribution are moving too fast to be decelerated at all. Others have speed that matches the experimental parameters and begin slowing down as soon as they enter the laser beam. Still others are moving so slowly that they do not interact until they have travelled to a point where the static but spatially varying magnetic field has decreased to the appropriate value. Thus all atoms with velocity slower than some selectable value are swept into a narrow velocity group. The result is that the originally wide thermal velocity distribution is compressed and shifted to lower velocities: this process is appropriately called laser cooling.

We measure the velocity distribution by detecting the fluorescence from atoms excited by a second, very weak laser propagating nearly parallel to the atomic beam. Because of the Doppler shift, the intensity of this fluorescence depends on the atomic velocity, and a slow scan of this laser's frequency results in a fluorescence signal that reflects the velocity distribution. This is done in an observation region about 50 cm beyond the end of the solenoid in order to avoid effects from its fringing field.

Because deceleration does not stop completely when the atoms leave the solenoid, many slow atoms are lost from the beam in the drift space between the end of the solenoid and the observation region. Therefore the laser beam is chopped and we delay observation, allowing the slow atoms to drift into the viewing region in the dark. Longer delays allow the observation of slower atoms, but there is a lower limit to the velocity we have observed, determined by beam divergence, collisions, etc.

In order to detect much slower atoms, we first decelerate them to about 50 m/s as described above, allow them to drift into the viewing region in the dark, and then further decelerate them with a short pulse of light (70 - 250 μs) from the cooling laser, delayed about 10 ms after the cooling process was terminated by the chopper. A 0.02 T field is

applied in the viewing region to Zeeman tune the atoms into resonance with the cooling laser. In this way we have produced a sample of decelerated atoms with a velocity distribution about 20 m/s FWHM centered at zero velocity. This second deceleration is very sensitive to the cooling laser frequency, and small tuning changes can result in large or small velocity changes as shown below. The zero of velocity (atomic resonance) is determined unambiguously by using a saturated-absorption cell that allows Doppler-free detection of the Na resonances. We have made a computer model of this deceleration process and compared the results with our measurements; this is also shown below. The data are the results of preliminary measurements that may be subject to some small systematic corrections whose estimated size is included in the error bars. The curves are for different values of laser power as indicated. Our best estimate of the power is about 200 mW, but the data fit the 275 mW curve better. This discrepancy may arise from beam profile effects, meter calibration, etc. It is clear that we can decelerate atoms to $v = 0$, and even reverse their direction. We can do this without a substantial increase in the width of the velocity distribution.

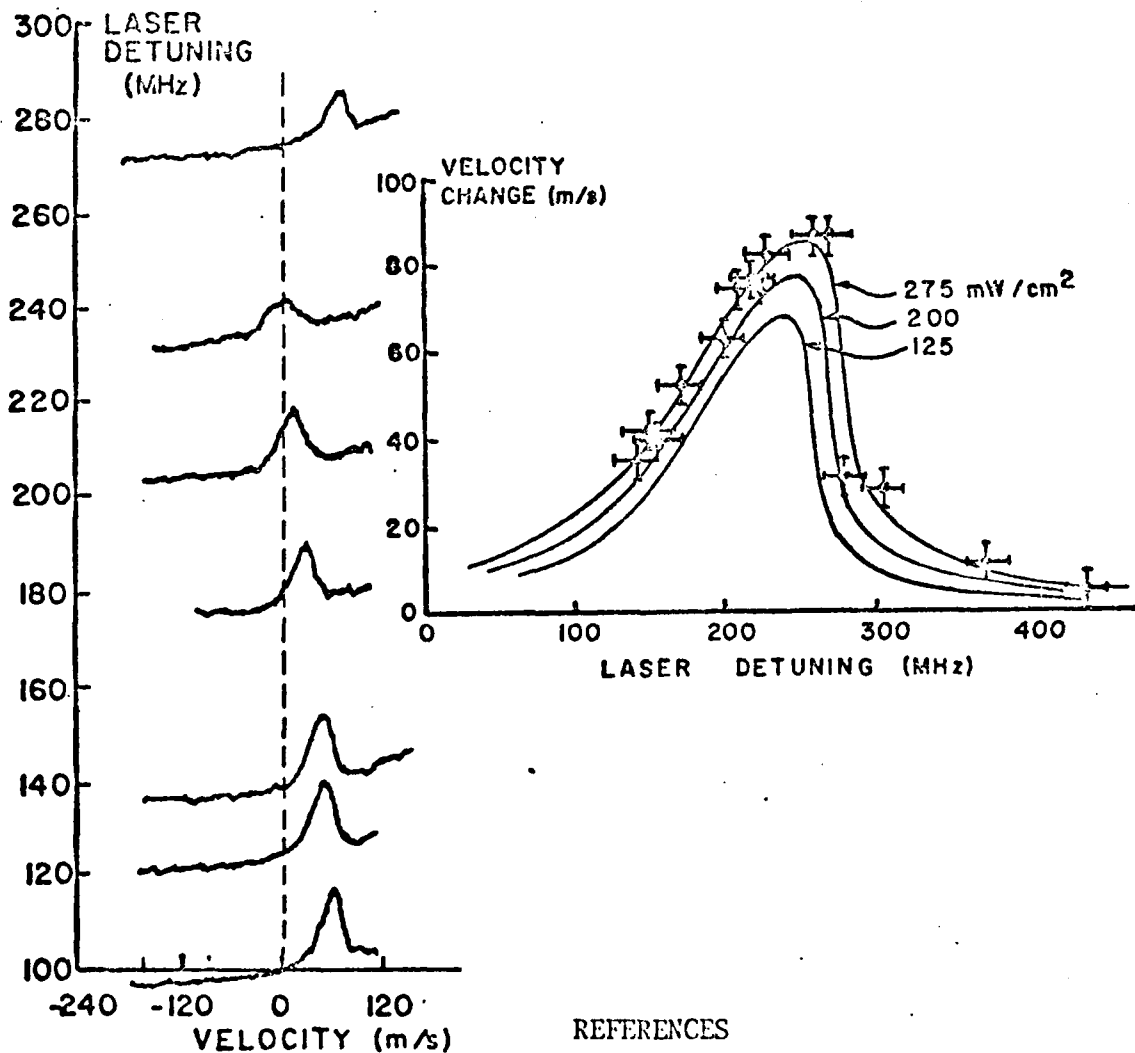

REFERENCES

- * Supported in part by the O.N.R. and the N.S.F.
 + Permanent address: S.U.N.Y., Stony Brook, N.Y., 11794
 1. W. Phillips and H. Metcalf, Phys. Rev. Lett. 48, 596 (1982); J. Prodan, W. Phillips, and H. Metcalf, Phys. Rev. Lett. 49, 1149 (1982).

END

FILMED

10-84

DTIC