

AD-A147 154

MERRIMACK RIVER BASIN
GROVELAND, MASSACHUSETTS

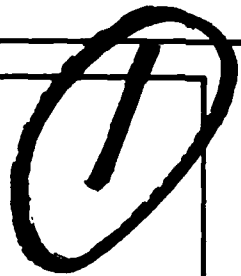

JOHNSON CREEK DAM
AT SALEM STREET
MA 00188

PHASE I INSPECTION REPORT
NATIONAL DAM INSPECTION PROGRAM

DTIC FILE COPY

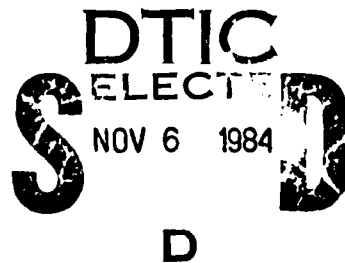

DEPARTMENT OF THE ARMY
NEW ENGLAND DIVISION, CORPS OF ENGINEERS
WALTHAM, MASS. 02154

DECLASSIFICATION STATEMENT A
Approved for public release;
Distribution Unlimited

OCTOBER 1979

84 10 29 031

UNCLASSIFIED

SECURITY CLASSIFICATION OF THIS PAGE (When Data Entered)

REPORT DOCUMENTATION PAGE		READ INSTRUCTIONS BEFORE COMPLETING FORM
1. REPORT NUMBER MA 00188	2. GOVT ACCESSION NO. AD-A147154	3. RECIPIENT'S CATALOG NUMBER
4. TITLE (and Subtitle) Johnson Creek Dam At Salem Street NATIONAL PROGRAM FOR INSPECTION OF NON-FEDERAL DAMS		5. TYPE OF REPORT & PERIOD COVERED INSPECTION REPORT
7. AUTHOR(s) U.S. ARMY CORPS OF ENGINEERS NEW ENGLAND DIVISION		6. PERFORMING ORG. REPORT NUMBER
9. PERFORMING ORGANIZATION NAME AND ADDRESS		8. CONTRACT OR GRANT NUMBER(s)
11. CONTROLLING OFFICE NAME AND ADDRESS DEPT. OF THE ARMY, CORPS OF ENGINEERS NEW ENGLAND DIVISION, NEDED 424 TRAPELO ROAD, WALTHAM, MA. 02254		10. PROGRAM ELEMENT, PROJECT, TASK AREA & WORK UNIT NUMBERS
12. REPORT DATE October 1979		13. NUMBER OF PAGES 65
14. MONITORING AGENCY NAME & ADDRESS (if different from Controlling Office)		15. SECURITY CLASS. (of this report) UNCLASSIFIED
		15a. DECLASSIFICATION/DOWNGRADING SCHEDULE
16. DISTRIBUTION STATEMENT (of this Report) APPROVAL FOR PUBLIC RELEASE: DISTRIBUTION UNLIMITED		
17. DISTRIBUTION STATEMENT (of the abstract entered in Block 20, if different from Report)		
18. SUPPLEMENTARY NOTES Cover program reads: Phase I Inspection Report, National Dam Inspection Program; however, the official title of the program is: National Program for Inspection of Non-Federal Dams; use cover date for date of report.		
19. KEY WORDS (Continue on reverse side if necessary and identify by block number) DAMS, INSPECTION, DAM SAFETY, Merrimack River Basin Groveland, Mass.		
20. ABSTRACT (Continue on reverse side if necessary and identify by block number) Johnson Creek Dam at Salem Street is an earthfill dam with a vertical downstream masonry wall. The dam is about 100 feet long and a maximum of 16 feet high. The dam is considered to be in fair condition. Johnson Creek Dam has been classified in the "small" size and the "significant" hazard categories. The test inflow ($\frac{1}{2}$ the PMF) was calculated to be 3,578 cubic feet per seconds.		



DEPARTMENT OF THE ARMY
NEW ENGLAND DIVISION, CORPS OF ENGINEERS
424 TRAPELO ROAD
WALTHAM, MASSACHUSETTS 02154

REPLY TO
ATTENTION OF:

NEDED

DEC 06 1979

Honorable Edward J. King
Governor of the Commonwealth of
Massachusetts
State House
Boston, Massachusetts 02133

Dear Governor King:

Inclosed is a copy of the Johnson Creek Dam at Salem Street Phase I Inspection Report, which was prepared under the National Program for Inspection of Non-Federal Dams. This report is presented for your use and is based upon a visual inspection, a review of the past performance and a brief hydrological study of the dam. A brief assessment is included at the beginning of the report. I have approved the report and support the findings and recommendations described in Section 7 and ask that you keep me informed of the actions taken to implement them. This follow-up action is a vitally important part of this program.

A copy of this report has been forwarded to the Department of Environmental Quality Engineering, the cooperating agency for the Commonwealth of Massachusetts. In addition, a copy of the report has also been furnished the owner, town of Groveland.

Copies of this report will be made available to the public, upon request, by this office under the Freedom of Information Act. In the case of this report the release date will be thirty days from the date of this letter.

I wish to take this opportunity to thank you and the Department of Environmental Quality Engineering for your cooperation in carrying out this program.

Sincerely,

MAX B. SCHEIDER
Colonel, Corps of Engineers
Division Engineer

Incl
As stated

JOHNSON CREEK DAM AT SALEM STREET

MA 00188

MERRIMACK RIVER BASIN
GROVELAND, MASSACHUSETTS

PHASE I INSPECTION REPORT
NATIONAL DAM INSPECTION
PROGRAM

Accession For	
NTIS GRA&I	<input checked="" type="checkbox"/>
DTIC TAB	<input type="checkbox"/>
Unannounced	<input type="checkbox"/>
Justification	
By _____	
Distribution/	
Availability Codes	
Dist	Avail and/or Special
A/1	



NATIONAL DAM INSPECTION
PROGRAM

PHASE I INSPECTION REPORT

BRIEF ASSESSMENT

Identification No.: MA00188

Name of Dam: Johnson Creek Dam at Salem Street

Town: Groveland

County and State: Essex County, Massachusetts

Stream: Johnson Creek - Tributary of the Merrimack
River

Date of Inspection: April 16, 1979

Johnson Creek Dam at Salem Street is an earth-fill dam with a vertical downstream masonry wall. The dam is about 100 feet long and a maximum of 16 feet high. Salem Street is a paved road located on the top of the dam which varies from elevation (El) 79.4 to El 79.6. Flow through a 5-foot diameter, corrugated steel culvert is controlled by removable stoplogs which serve as the spillway for the dam. The effective length of the stoplogs is 8 feet. At the time of inspection, the top of the stoplogs was at El 73.7. The upstream invert of the culvert is at El 66.0. There is also a 6-inch diameter, low-level outlet that discharges at the upstream end of the corrugated steel culvert. The invert of the outlet is at El 65.6.

Johnsons Pond is comprised of a lower pond (16 acres) impounded by Johnson Creek Dam at Salem Street and an upper pond (181 acres) impounded by Johnsons Pond Dam at Washington Street. Water in the lower pond is used to maintain flow downstream in Johnson Creek, while the upper pond is used for water supply. The difference in elevation between the water surfaces of the upper and lower ponds is 1.4 feet.

Based on a visual inspection of the site and a review of previous inspection reports, the dam is considered to be in fair condition. Additional maintenance is required to assure the continued performance of this dam. The maintenance items include selective

JOHNSON CREEK DAM AT SALEM STREET

clearing of trees and brush, repair of the downstream wall, repair of erosion around the culvert headwall, installation of stone riprap on the upstream face of the dam, provide a mechanism for removal of the stoplogs and clear the debris downstream of the stoplogs.

Based on Corps of Engineers' guidelines, Johnson Creek Dam has been classified in the "small" size and the "significant" hazard categories. The total drainage area for the upper and lower ponds is 5.3 square miles. The test flood inflow (one-half the probable maximum flood (PMF)) was calculated to be 3,578 cubic feet per second (cfs). The peak test flood outflow of 1,940 cfs with the pond at El 81.7 will overtop the dam by 2.3 feet. The stoplogs and culvert can discharge 230 cfs, which is 15 percent of the test flood before the dam is overtopped.

It is recommended that the Owner employ a qualified engineering consultant to complete a detailed hydraulic and hydrologic analysis of the dam. In addition, it is recommended that the Owner implement the maintenance items listed above and institute systematic programs of inspection, maintenance, surveillance, and a warning system for the dam.

The measures outlined above and in Section 7 should be implemented by the Owner within a period of one year after receipt of this Phase 1 Inspection Report. An alternative to implementing these measures would be to remove all the stoplogs at the dam.



Edward M. Greco

Edward M. Greco, P.E.
Project Manager
Metcalf & Eddy, Inc.

Connecticut Registration
No. 08365

Approved by:

Stephen L. Bishop

Stephen L. Bishop, P.E.
Vice President
Metcalf & Eddy, Inc.



Massachusetts Registration
No. 19703

JOHNSON CREEK DAM AT SALEM STREET

This Phase I Inspection Report on Johnson Creek Dam at Salem Street has been reviewed by the undersigned Review Board members. In our opinion, the reported findings, conclusions, and recommendations are consistent with the Recommended Guidelines for Safety Inspection of Dams, and with good engineering judgment and practice, and is hereby submitted for approval.

Joseph W. Finegan

JOSEPH W. FINEGAN, JR., MEMBER
Water Control Branch
Engineering Division

Joseph A. McElroy

JOSEPH A. MCELROY, MEMBER
Foundation & Materials Branch
Engineering Division

Carney M. Terzian

CARNEY M. TERZIAN, CHAIRMAN
Chief, Structural Section
Design Branch
Engineering Division

APPROVAL RECOMMENDED:

Joe B. Fryar

JOE B. FRYAR
Chief, Engineering Division

PREFACE

This report is prepared under guidance contained in Recommended Guidelines for Safety Inspection of Dams, for a Phase I Investigation. Copies of these guidelines may be obtained from the Office of Chief of Engineers, Washington, D.C. 20314. The purpose of a Phase I Investigation is to identify expeditiously those dams which may pose hazards to human life or property. The assessment of the general condition of the dam is based upon available data and visual inspections. Detailed investigations, and analyses involving topographic mapping, subsurface investigations, testing, and detailed computational evaluations are beyond the scope of a Phase I investigation; however, the investigation is intended to identify any need for such studies.

In reviewing this report, it should be realized that the reported condition of the dam is based on observations of field conditions at the time of inspection along with data available to the inspection team. In cases where the reservoir was lowered or drained prior to inspection, such action, while improving the stability and safety of the dam, removes the normal load on the structure and may obscure certain conditions which might otherwise be detectable if inspected under the normal operating environment of the structure.

It is important to note that the condition of a dam depends on numerous and constantly changing internal and external conditions, and is evolutionary in nature. It would be incorrect to assume that the present condition of the dam will continue to represent the condition of the dam at some point in the future. Only through continued care and inspection can there be any chance that unsafe conditions will be detected.

Phase I inspections are not intended to provide detailed hydrologic and hydraulic analyses. In accordance with the established Guidelines, the Spillway Test Flood is based on the estimated "Probable Maximum Flood" for the region (greatest reasonably possible storm runoff), or fractions thereof. Because of the magnitude and rarity of such a storm event, a finding that a spillway will not pass the test flood should not be interpreted as necessarily posing a highly inadequate condition. The test flood provides a measure of relative spillway capacity and serves as an aid in determining the need for more detailed hydrologic and hydraulic studies, considering the size of the dam, its general conditions and the downstream damage potential.

JOHNSON CREEK DAM AT SALEM STREET

TABLE OF CONTENTS

	<u>Page</u>
BRIEF ASSESSMENT	
PREFACE	
OVERVIEW PHOTO	111
LOCATION MAP	iv
REPORT	
SECTION 1 - PROJECT INFORMATION	1
1.1 General	1
1.2 Description of Project	1
1.3 Pertinent Data	5
SECTION 2 - ENGINEERING DATA	9
2.1 General	9
2.2 Construction Records	9
2.3 Operating Records	9
2.4 Evaluation	9
SECTION 3 - VISUAL INSPECTION	10
3.1 Findings	10
3.2 Evaluation	12
SECTION 4 - OPERATING PROCEDURES	13
4.1 Procedures	13
4.2 Maintenance of Dam	13
4.3 Maintenance of Operating Facilities	13
4.4 Description of Any Warning System in Effect	13
4.5 Evaluation	13
SECTION 5 - HYDRAULIC/HYDROLOGIC	14
5.1 Evaluation of Features	14

JOHNSON CREEK DAM AT SALEM STREET

TABLE OF CONTENTS (Continued)

	<u>Page</u>
SECTION 6 - STRUCTURAL STABILITY	18
6.1 Evaluation of Structural Stability	18
SECTION 7 - ASSESSMENT, RECOMMENDATIONS, AND REMEDIAL MEASURES	20
7.1 Dam Assessment	20
7.2 Recommendations	20
7.3 Remedial Measures	21
7.4 Alternatives	22

APPENDIXES

APPENDIX A - PERIODIC INSPECTION CHECKLIST	
APPENDIX B - PLANS OF DAM AND PREVIOUS INSPECTION REPORTS	
APPENDIX C - PHOTOGRAPHS	
APPENDIX D - HYDROLOGIC AND HYDRAULIC COMPUTATIONS	
APPENDIX E - INFORMATION AS CONTAINED IN THE NATIONAL INVENTORY OF DAMS	

**OVERVIEW
JOHNSON CREEK DAM AT SALEM STREET
GROVELAND, MASSACHUSETTS**



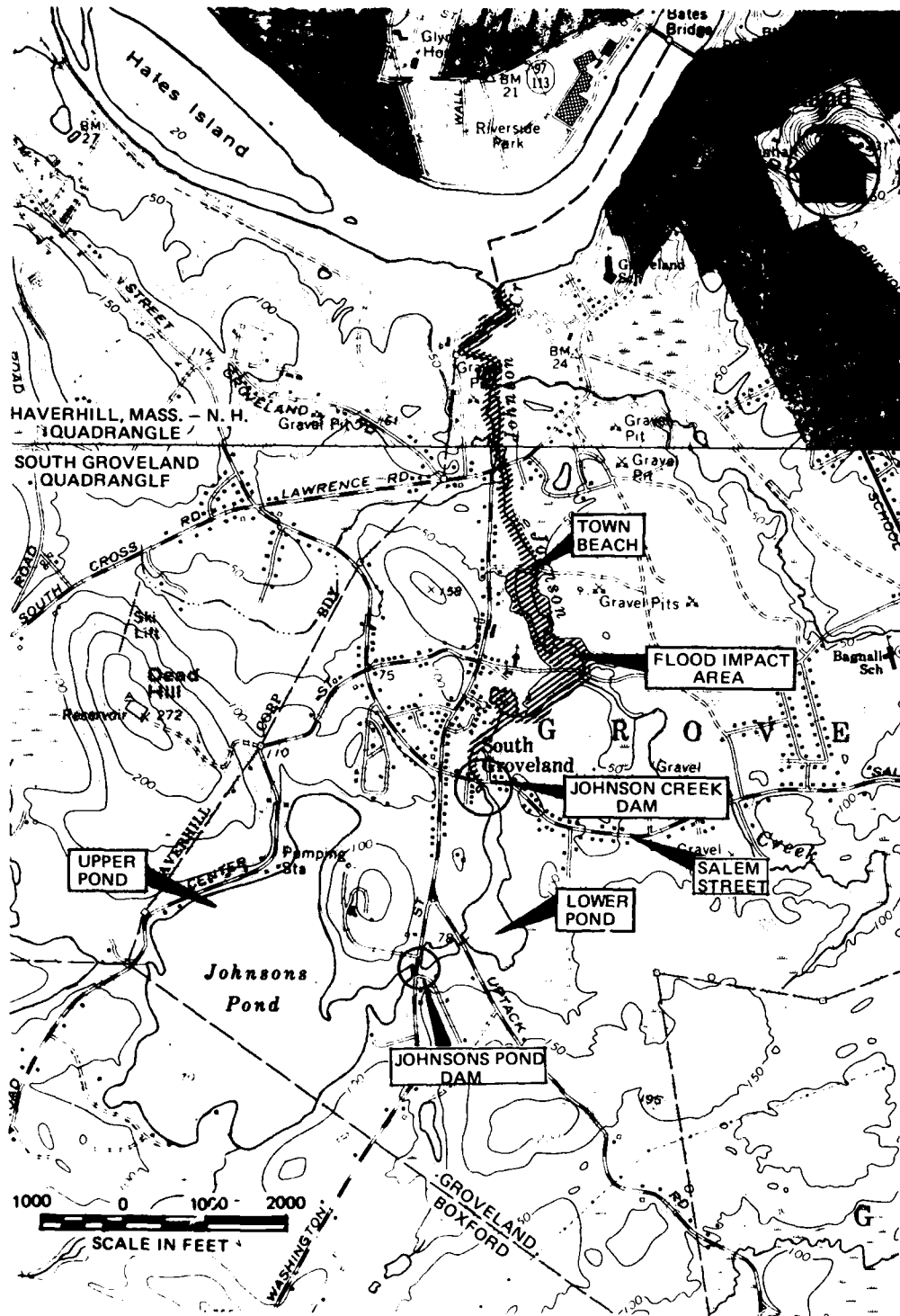

LOCATION MAP - JOHNSON CREEK AT SALEM STREET

NATIONAL DAM INSPECTION
PROGRAM

PHASE I INSPECTION REPORT
JOHNSON CREEK DAM

SECTION 1

PROJECT INFORMATION

1.1 General

- a. Authority. Public Law 92-367, dated August 8, 1972, authorized the Secretary of the Army, through the Corps of Engineers, to initiate a national program of dam inspection throughout the United States. The New England Division of the Corps of Engineers has been assigned the responsibility of supervising the inspection of dams within the New England Region. Metcalf & Eddy, Inc. has been retained by the New England Division to inspect and report on selected dams in the State of Massachusetts. Contract No. DACW 33-79-C-0054, dated March 27, 1979, has been assigned by the Corps of Engineers for this work.
- b. Purpose:
- (1) Perform technical inspection and evaluation of non-Federal dams to identify conditions which threaten the public safety and thus permit correction in a timely manner by non-Federal interests.
 - (2) Encourage and assist the States to quickly initiate effective dam safety programs for non-Federal dams.
 - (3) Update, verify and complete the National Inventory of Dams.

1.2 Description of Project

- a. Location. The dam is located on Johnson Creek at Salem Street in the Town of Groveland, Essex County, Massachusetts (see Location Map and Figure D-1, Drainage Area Map). The

JOHNSON CREEK DAM AT SALEM STREET

coordinates of this location are Latitude 42 deg. 44.3 min. north and Longitude 71 deg. 2.6 min. west. Johnson's Pond Dam, located upstream, is also shown on the Location Map. Johnson Creek is a tributary of the Merrimack River.

- b. Description of Dam and Appurtenances. Johnson Creek Dam at Salem Street consists of an earth-fill dam with a vertical stone masonry wall on the downstream face (see Figures B-1 and B-2 and photographs in Appendix C). The dam is about 100 feet long and a maximum of 16 feet high. Salem Street, a paved two-lane roadway, is located on the top of the dam. The top of the dam varies from El 79.4 to El 79.6 and is about 60 feet wide, including the 30-foot wide roadway. The upstream face of the dam (see photograph No. 1) gently slopes at approximately 6:1 (horizontal:vertical). The downstream face is a vertical mortared stone wall (see photograph No. 3). The ends of the wall tie into steep valley slopes that form the abutments of the dam.

The spillway consists of a concrete structure containing stoplogs located upstream of a culvert through the embankment. The structure contains a 35-foot long concrete headwall around the culvert and two concrete sidewalls which support 3-inch thick, wooden, removable stoplogs. The top of the sidewalls are at El 75. At the time of the inspection, the top of the stoplogs was at El 73.7 while the bed of the pond is at El 67.0. The effective length of the stoplogs is 8 feet. A metal grate is located on top of the concrete structure. The culvert is a 5-foot diameter, corrugated steel pipe which runs at an angle through the dam.

There is also a low-level, gated outlet which passes through a concrete sill at the base of the stoplogs. The outlet is a 6-inch diameter, cast-iron pipe with an invert at El 65.6. The location of the upstream end of the outlet is unknown. The downstream end of the outlet is slightly below and just upstream of the culvert. Flow would discharge into the culvert.

JOHNSON CREEK DAM AT SALEM STREET

Two roadways cross Johnsons Pond about 1/2 mile upstream of the dam. The Washington Street embankment has been termed the Johnsons Pond Dam and impounds an upper pond which is 1.4 foot above the lower pond impounded by Johnson Creek Dam. The Haverhill Water Department maintains the stoplogs at the inlet to the culvert under Johnsons Pond Dam (see photograph No. 6). The culvert is a 5-foot diameter steel pipe with an invert at El 70.5 (see Section 1-1 on Figure B-3). Johnsons Pond Dam is estimated to be about 105 feet long. The top of the dam varies from El 79.0 to El 80.0. Downstream of Washington Street, the embankment of Uptack Road crosses Johnsons Pond. Flow passes uncontrolled through this embankment in a box culvert 6.3 feet wide by 7 feet high (see Section 2-2 on Figure B-3). The section of roadway that crosses the pond is 150 feet long and varies from El 78.2 to El 78.8 (see photograph No. 5).

- c. Size Classification. Johnson Creek Dam is classified in the "small" category since it has a maximum height of 16 feet and a maximum storage capacity of 220 acre-feet. This storage capacity includes the lower pond impounded by Johnson Creek Dam and the upper pond impounded by Johnsons Pond Dam.
- d. Hazard Classification. The dam is located in a moderately residential area of Groveland and the town beach is situated about 3/4 mile downstream. Although it is unlikely that a failure of the dam would cause structural damage downstream, it is possible that loss of life could occur in the town beach area. Accordingly, the dam has been placed in the "significant" hazard category.
- e. Ownership. The dam at Salem Street is owned by the Town of Groveland. The Town also owns the Johnsons Pond Dam. Mr. Herbert Esty, Chairman of the Board of Selectmen (telephone: 617-374-0333), Town Hall, Groveland, Massachusetts was informed of this inspection.

JOHNSON CREEK DAM AT SALEM STREET

- f. Operators. The dam at Salem Street is operated by personnel from the Town of Groveland Water Department. Johnsons Pond Dam is operated by personnel from the Haverhill Water Department who also operate the pumping station at the upper pond.
- g. Purpose of the Dam. The dam originally provided water power to Groveland Mill. According to past inspection reports, the dam was not used by the mill from 1931 to 1955, and the pond was empty. Today, the dam is used to regulate flow to areas downstream along Johnsons Creek. Specifically, it is used in the summer to maintain the water level at the town beach located $3/4$ mile downstream.
- h. Design and Construction History. The dam was constructed sometime prior to 1913, when the first inspection of the dam was made. The only data available on the design and construction history are the previous inspection reports by the Essex County Engineering Department (see copies in Appendix B). The reports state that in June 1917, extensive repairs were made to the dam after a failure occurred and emptied the pond. From 1931 to 1955, the dam was not in use and the pond was empty. The timbers and old mill flume deteriorated and began collapsing. In 1955, a new concrete structure with stoplogs and a new corrugated steel culvert were constructed at the dam. It was noted that the stoplogs were "spiked" together and could not be removed during high water. No repairs or changes to the dam have been reported since that time.
- i. Normal Operating Procedures. The stoplogs are occasionally adjusted to maintain a flow of water during the summer to the downstream beach area. The low-level outlet is closed and not used. The stoplogs upstream at Washington Street are kept in place to maintain the maximum storage for water supply purposes.

JOHNSON CREEK DAM AT SALEM STREET

1.3 Pertinent Data

- a. Drainage Area. Johnsons Pond (upper and lower ponds) has a drainage area of 5.3 square miles (3,392 acres) and extends into the Towns of Groveland, Haverhill, and Boxford, Massachusetts (see Drainage Area Map, Figure D-1). The area consists of sparsely developed, moderately steep, hilly land with numerous swamps and ponds. Chadwick Pond and Hoveys Pond are two large ponds included within the drainage area. Several roads cross the drainage area, and houses are located along these roads.

- b. Discharge. Discharge from Johnsons Pond (lower pond) flows over stoplogs (at El 73.7) and beneath Salem Street in a 5-foot diameter corrugated steel culvert. The culvert discharges into a stream channel with steep side slopes. There are several residences along the channel but these are located much higher than the stream and would not be effected by a failure of the dam. There are two ponds and two roadway culverts within the downstream channel through which the discharge must pass before finally reaching the Merrimack River about 1.5 miles downstream. The land east of the discharge channel is presently gravel pits.

Hydraulic analyses indicate that the stoplogs and culvert can discharge a flow of 230 cfs with the pond at El 79.4, which is the low area on the top of the dam. The test flood outflow (one-half PMF) is estimated to be 1,940 cfs with the pond at El 81.7 and will overtop the dam by a maximum of 2.3 feet. The stoplogs and culvert can discharge 15 percent of the test flood before the dam is overtopped.

There is no information on previous flood levels at Johnson Creek Dam. Personnel at the pumping station report that the maximum operating pool at the upper pond is 14.5 feet above the intake which equates to El 76.4. They do not recall any flow passing over the Washington Street Dam.

JOHNSON CREEK DAM AT SALEM STREET

c. Elevation (feet above Mean Sea Level (MSL)).
A benchmark was established at El 80.1 on the top of the outlet headwall at Washington Street (see Figure B-3). This elevation is shown on proposed construction drawings of the headwall.

- (1) Top of dam: 79.4 to 79.6
- (2) Test flood pool: 81.7
- (3) Design surcharge: Unknown
- (4) Full flood control pool: Not Applicable (N/A)
- (5) Recreation pool: N/A
- (6) Spillway crest (top of stoplogs - lower pond): 73.7
- (7) Upstream portal invert diversion tunnel: N/A
- (8) Streambed at centerline of dam: 63.5
- (9) Tailwater: 65.3

d. Reservoir

- (1) Length of maximum pool: 2,800 feet to Washington Street (Johnsons Pond Dam); 3,400 feet to western edge of upper pond
- (2) Length of recreation pool: N/A
- (3) Length of flood control pool: N/A

e. Storage (acre-feet)

- (1) Test flood surcharge (net): 620 at El 81.7
- (2) Top of dam (El 79.4): 220
- (3) Flood control pool: N/A
- (4) Recreation pool: N/A
- (5) Spillway crest (El 73.7): 55

JOHNSON CREEK DAM AT SALEM STREET

f. Reservoir Surface (acres)

- * (1) Top of dam (upper and lower ponds): 197
- * (2) Test flood pool (upper and lower ponds): 197
- (3) Flood control pool: N/A
- (4) Recreation pool: N/A
- (5) Spillway crest (lower pond): 16

g. Dam

- (1) Type: earthfill
- (2) Length: 100 feet
- (3) Height: 16 feet (maximum)
- (4) Top width: 60 feet
- (5) Side slopes: upstream - 6:1
downstream - vertical
stone wall
- (6) Zoning: Unknown
- (7) Impervious core: Unknown
- (8) Cutoff: Unknown
- (9) Grout curtain: Unknown

h. Spillway

- (1) Type: Wooden stoplogs
- (2) Length of weir: 8 feet
- (3) Crest elevation: 73.7 - top of removable stoplogs at the time of the inspection.

*Based on the assumption that the surface area will not increase significantly with change in reservoir elevation from 73.7 to 81.7.

JOHNSON CREEK DAM AT SALEM STREET

(4) Gates: None

(5) Upstream channel: natural pond bottom

(6) Downstream channel: 5-foot diameter, corrugated metal culvert through embankment discharges into stream channel with gravel/cobble bottom and steep earth sides.

1. Regulating Outlets. The water level in the pond is normally regulated by adjusting the stoplogs which act as the spillway for the dam. The stoplogs extend down to approximately the bottom of the pond (El 67) although removal during a storm would be difficult without the use of heavy equipment. There is a 6-inch diameter, low-level outlet pipe at the base of the stoplogs. However, this outlet has not been used for many years and there is no operating mechanism on the control valve.

JOHNSON CREEK DAM AT SALEM STREET

SECTION 2

ENGINEERING DATA

- 2.1 General. There are no known plans, specifications or computations available from the Owner, County or State offices relative to the design, construction or repair of this dam. The only available data are previous inspection reports obtained from the Essex County Engineering Department. Copies of these reports are included in Appendix B (see pages B-4 through B-10).

We acknowledge the assistance and cooperation of personnel from the Massachusetts Division of Waterways, the Massachusetts Department of Public Works, the Town of Groveland and the Haverhill Water Department.

- 2.2 Construction Records. There are no as-built drawings available for the dam or appurtenances.
- 2.3 Operating Records. No operating records are available, and there is no daily record kept of the elevation of the pool or rainfall at the dam site.
- 2.4 Evaluation
- a. Availability. There is no engineering data available for this dam.
 - b. Adequacy. The lack of detailed hydraulic, structural and construction data did not allow for a definitive review. Therefore, the evaluation of the adequacy of this dam is based on the visual inspection, past performance history, and engineering judgment.
 - c. Validity. Comparison of the available previous inspection reports with the field survey conducted during the Phase I inspection indicates that the available information is valid.

JOHNSON CREEK DAM AT SALEM STREET

SECTION 3

VISUAL INSPECTION

3.1 Findings

- a. General. The Phase I Inspection of the dam at Johnson Creek was performed on April 16, 1979. A copy of the inspection checklist is included in Appendix A. Notes from past inspections, on file with the Engineering Department, Essex County, Massachusetts, are included in Appendix B.
- b. Dam. Johnson Creek Dam is an 100-foot long, 16-foot high earthfill dam with a vertical downstream masonry wall. The spillway consists of a corrugated metal culvert through the dam controlled by stoplogs at the upstream end.

The dam is in fair condition, although there are some areas which require maintenance. The top of the dam carries a two-lane road. The pavement is cracked and in fair condition. Two catchbasins at the low area on the dam collect surface runoff from the roadway and discharge the water through a concrete pipe. The pipe terminates at the downstream wall of the dam, and the water discharges into the downstream channel.

The downstream wall consists of mortared stone masonry that is generally in good condition, although several smaller stones were missing at the foundation level (see photograph No. 4). The mortared joints are generally intact. The wall is topped by a concrete cap which is also in good condition. No evidence of seepage was noted at the downstream wall. Water was discharging from the culvert into the channel at the time of the inspection.

A bituminous concrete sidewalk is located on the downstream side of the road and pedestrians are protected from the edge of the dam by a chain-link fence.

JOHNSON CREEK DAM AT SALEM STREET

The upstream face of the dam gently slopes toward the pond on approximately a 6:1 slope. A concrete headwall is located at the upstream end of the culvert through the dam.

The upstream face of the dam is covered with grass and there is no riprap protection. Several trees about 6 to 12 inches in diameter are located on the upstream face.

Several areas of minor erosion were noted on the dam. Drainage from the sidewalk is apparently causing some minor erosion along the eastern bank of the downstream channel at the wall. Erosion was also noted at several areas along the upstream face of the dam, in particular, at the west end of the concrete headwall.

- c. Appurtenant Structures. There is a concrete structure upstream of the concrete headwall and culvert through the dam. This structure supports two bays of stoplogs and contains a low-level outlet pipe. The structure consists of vertical concrete sidewalls, a concrete sill at the base of the stoplogs, and a central concrete pillar separating the two bays of stoplogs. A metal grating spans the sidewalls of the structure and provides access to the stoplogs. There is a low-level outlet pipe that passes through the concrete sill of the east bay of the stoplogs. A gate valve on the pipe is located immediately downstream of the stoplogs.

The stoplogs are wedged in place and appear to be difficult to remove. The concrete comprising the outlet structure is in good condition. The approach channel to the outlet is clear of debris, but there is an accumulation of wood and trash downstream of the stoplogs in front of the culvert opening. The low-level outlet is not used and may not be operable. The operating mechanism for the gate valve is missing. The valve is located about 9 feet below the metal grating and underneath water discharging over the stoplogs. This would make the valve difficult to operate during periods of heavy runoff. There is

JOHNSON CREEK DAM AT SALEM STREET

minor corrosion on the pipe and valve. The corrugated metal culvert is in good condition and clear of debris.

- d. Reservoir Area. The area around Johnsons Pond is sparsely developed. Several residences are located around the upper pond. Two roadways, Washington Street and Uptack Road, cross the pond. The Washington Street embankment forms the Johnsons Pond Dam, separating the pond into an upper and lower pond.
 - e. Downstream Channel. Discharge from the dam flows in a narrow downstream channel with steep slopes (see photograph No. 2). There are no residences located within the channel. Some residences adjacent to the channel are on higher ground and would not be affected by a flood wave. Although the banks of the channel are tree-lined, the channel is not clogged. Two roadways cross the channel before it discharges into the Merrimack River about 1.5 miles downstream from the dam. Two ponds are also located downstream. The Town of Groveland operates a beach on the lower pond.
- 3.2 Evaluation. The above findings indicate that the dam is in fair condition and that there are several areas which require maintenance. Remedial measures to improve this condition are stated in Section 7.3.

JOHNSON CREEK DAM AT SALEM STREET

SECTION 4

OPERATING PROCEDURES

- 4.1 Procedures. The only operating procedure at the dam is occasional raising or lowering of the stoplogs. This is done especially during the summer to maintain an adequate flow of water to the town beach located downstream.
- 4.2 Maintenance of Dam. The dam is not adequately maintained. Trees and brush are growing on the embankment, stonework is missing on the downstream wall, erosion has occurred around the culvert headwall, and riprap is missing on the upstream slope of the dam.
- 4.3 Maintenance of Operating Facilities. Although the concrete on the stoplog structure is in good condition, there is no provision for easy removal of stoplogs during periods of heavy runoff. The low-level outlet has not been used recently, and there is no operating mechanism for the gate valve.
- 4.4 Description of Any Warning System in Effect. There are no warning systems in effect at this dam.
- 4.5 Evaluation. There are no programs of maintenance or technical inspections in effect at Johnson Creek Dam. There is also no surveillance system for periods of heavy runoff or a warning system for people in downstream areas. This is undesirable considering that the dam is in the "significant" hazard category. These programs should be implemented as recommended in Section 7.3

JOHNSON CREEK DAM AT SALEM STREET

SECTION 5

HYDRAULIC/HYDROLOGIC

5.1 Evaluation of Features

- a. General. Johnson's Pond is comprised of a lower and an upper pond impounded by Johnson Creek Dam and Johnsons Pond Dam, respectively. Drainage into Johnson Pond originates principally in wooded hills in the City of Haverhill. The tributary drainage area consists of about 3,392 acres (5.3 square miles) of sparsely populated land. About 9 percent of the area consists of ponds and swamps. The maximum storage capacity of Johnson Creek Dam is estimated to be 220 acre-feet.

The dam on Johnson Creek at Salem Street is an earthfill dam with a vertical masonry downstream wall. A 5-foot diameter corrugated steel pipe controlled by stoplogs functions as a spillway. At the time of the inspection, the top of the stoplogs was at El 73.7 feet, which is essentially the highest level available. Removal of all stoplogs would substantially lower the pond to El 67. The upstream invert of the culvert is at El 66.0. A 6-inch diameter low-level outlet pipe passes underneath the stoplogs and would discharge into the culvert. However, this outlet has not been operated in many years. The invert of the low-level pipe is at El 65.6.

Johnsons Pond Dam at Washington Street is also controlled by stoplogs and is located upstream of the dam at Salem Street. At the time of the inspection, the top of the stoplogs was at El 75.4, about 1.7 feet higher than the dam at Salem Street. Removal of all stoplogs could lower the pond to El 70.5, which is the invert of the culvert under Washington Street.

The embankment of Uptack Road crosses the lower pond about 600 feet downstream of Washington Street. A 6.3-foot by 7-foot box culvert with an invert at El 70.2 is located beneath the road.

JOHNSON CREEK DAM AT SALEM STREET

- b. Design Data. There are no hydraulic or hydrologic computations available for the design of the dam.
- c. Experience Data. There is no information available on past flood levels at the dam. Personnel at the pumping station at the upper pond do not recall that Washington Street has ever been overtopped.
- d. Visual Observations. The concrete structure that supports the stoplogs is in good condition, and the stoplogs are intact. However, debris has accumulated at the opening to the culvert. There is some erosion behind the headwall of the culvert. The downstream channel is clear of debris, although there are overhanging trees. Some smaller trees and brush were noted within the channel.
- e. Test Flood Analysis. The dam on Johnson Creek at Salem Street has been placed in the "small" size and "significant" hazard categories. According to the Corps of Engineers' guidelines, a test flood ranging from a 100-year storm to a one-half PMF should be used to evaluate the capacity of the spillway. The one-half PMF was used in this analysis.

The full PMF rate was determined to be 1,350 cfs per square mile. This calculation is based on the average slope of the drainage area of 2 percent, the pond-plus-swamp area to drainage area ratio of 8.9 percent, and the U.S. Army Corps of Engineers' guide curves for Maximum Probable Flood Peak Flow Rates (dated December 1977). Applying one-half the full PMF to the 5.3 square miles of drainage area results in a calculated peak flow of 3,578 cfs as the test flood inflow.

Because there are two dams at Johnsons Pond (Salem Street and Washington Street), the test flood analysis was performed for four theoretical conditions encompassing both dams. By adjusting each condition for surcharge storage, the maximum discharge rates at the Johnson Creek Dam (Salem Street) were established as follows:

JOHNSON CREEK DAM AT SALEM STREET

1. All stoplogs at both Washington and Salem Street dams in place; maximum discharge rate 1,940 cfs with water surface at El 81.7 (2.3 feet over dam).
2. Stoplogs at Salem Street dam removed; maximum discharge rate 1,970 cfs with water surface at El 81.5 (2.1 feet over dam).
3. Stoplogs at Washington Street dam removed; maximum discharge rate 1,580 cfs with water surface at El 81.3 (1.9 feet over dam).
4. All stoplogs at Washington and Salem Street dams removed; maximum discharge rate 940 cfs with water surface at El 80.5 (1.1 feet over dam).

As noted above, the dam at Salem Street would be overtopped in every case. Overtopping will occur when the water level upstream of the dam at Salem Street reaches El 79.4. The hydraulic analysis indicates that the height of stoplogs at either dam has little effect on the amount of overtopping that would occur at the Salem Street dam.

Hydraulic analyses indicate that the spillway at Salem Street can discharge 30 cfs with the stoplogs in place and 340 cfs with the stoplogs removed. This corresponds to 12 and 17 percent of the test flood outflow, respectively.

- f. Dam Failure Analysis. Assuming a failure of the Johnson Creek Dam with the water surface at El 79.4 which is the low area on the crest of the dam, the peak discharge flood flow would be about 3,800 cfs, including a discharge of 230 cfs from the culvert. This discharge would produce a 6.5-foot depth of flow in the downstream channel as compared to a 1-foot depth of flow prior to failure. It is estimated that the pond would drain in about 1.5 hours.

JOHNSON CREEK DAM AT SALEM STREET

The flood wave should have little effect upon surrounding property. However, there is a potential for loss of life in areas downstream, particularly in the town beach area. Accordingly, the dam has been placed in the "significant" hazard category.

JOHNSON CREEK DAM AT SALEM STREET

SECTION 6

STRUCTURAL STABILITY

6.1 Evaluation of Structural Stability

- a. Visual Observations. The evaluation of the structural stability of Johnson Creek Dam is based on the visual inspection conducted on April 16, 1979. A detailed discussion of the visual inspection is given in Section 3, Visual Inspection. Based on this inspection, the dam is in fair condition. Since the top of the dam is wide and much of it is paved, overtopping would cause minimal erosion. However, riprap should be placed on the upstream face of the dam. Minor erosion has occurred behind the headwall of the outlet, but this has little significance to the stability of the dam. The downstream vertical masonry wall appears to be in good condition. Several stones which are missing at the base of the wall should be replaced. Because the culvert was discharging at the time of the inspection, the presence of seepage at the base of the wall could not be completely determined.
- b. Design and Construction Data. There are no records, plans or calculations available on the design and construction of the dam.

Information does not appear to exist on the type, shear strength and permeability of the soil and/or rock materials of the embankment.
- c. Operating Records. There is no instrumentation of any type in Johnson Creek Dam and no instrumentation was ever reportedly installed. The performance of this dam under prior loading can only be inferred from physical evidence at the site.
- d. Post-Costruction Changes. There are no as-built drawings available for Johnson Creek Dam. Based on previous inspection reports, the dam has been repaired in the past. A

JOHNSON CREEK DAM AT SALEM STREET

report dated November 15, 1913 indicated that a new wall was put in when the street was widened. A report dated June 16, 1917 states that a culvert had been repaired and new timber sheeting was installed to repair a portion of the dam that failed. Inspection reports indicate that from 1931 to 1955, the pond was empty and the dam was deteriorating. In 1955, the concrete structure with stoplogs and the corrugated steel culvert were installed at the dam.

- e. Seismic Stability. The dam is located in Seismic Zone No. 3. In accordance with Phase I "Recommended Guidelines", a stability analysis should be made. Information on the foundation soils and construction materials are not available, therefore, an evaluation of the static and seismic stability of the embankment cannot be made at this time. However, because of the low head, short length, and wide top of the dam, seismic-induced failures are unlikely. A seismic stability analysis is not warranted.

SECTION 7

ASSESSMENT, RECOMMENDATIONS, AND REMEDIAL MEASURES

7.1 Dam Assessment

- a. Condition. Based upon a visual inspection of the dam and a review of past inspection reports and hydraulic analyses, this dam is considered to be in fair condition. There is some maintenance required on the dam.

Hydraulic analyses indicate that the stoplogs and culvert can discharge a flow of 230 cfs with a water surface at El 79.4, which is the low area on the top of the dam. An outflow test flood (one-half PMF) of 1,940 cfs will overtop the dam by a maximum of 2.3 feet. This assumes all stoplogs are in place at both the Washington Street and Salem Street dams. The stoplogs and culvert can discharge 12 percent of the test flood without overtopping the dam.

- b. Adequacy. The lack of detailed design and construction data did not allow for a definitive review. Therefore, the evaluation of the adequacy of this dam is based primarily on the visual inspection, past performance and engineering judgment.
- c. Urgency. The recommendations and remedial measures outlined below should be implemented by the Owner within one year after receipt of this Phase I Inspection Report.
- d. Need for Additional Investigation. Additional investigations to further assess the adequacy of the dam are outlined below in Section 7.2, Recommendations.

- 7.2 Recommendations. It is recommended that the Owner employ the services of a qualified engineering consultant to conduct a more detailed hydraulic and hydrologic investigation and to evaluate the discharge capacity at the dam. The study should include an analysis of the potential flood modifying effect of upstream ponds and natural valley storage areas. The Owner should implement the recommendations by the Consultant.

JOHNSON CREEK DAM AT SALEM STREET

7.3 Remedial Measures

a. Operating and Maintenance Procedures. It is recommended that the Owner accomplish the following:

- (1) Selectively clear trees, brush and roots from the upstream face of the dam and from the downstream channel for a distance of 25 feet from the downstream wall. Trees, brush and roots should also be cleared from within 5 feet of the base of the downstream wall. Any holes left from clearing of roots should be backfilled with selected material.
- (2) Repair stones missing from the masonry wall on the downstream face of the dam.
- (3) Repair erosion behind the headwall of the culvert.
- (4) Place stone riprap along the upstream face of the dam.
- (5) Make provisions to remove the stoplogs during periods of heavy rainfall.
- (6) Clear debris from in front of the opening of the culvert.
- (7) Implement a systematic program of maintenance inspections. As a minimum, the inspection program should consist of a monthly inspection of the dam and appurtenances, supplemented by additional inspections during and after severe storms. Repairs and maintenance should be undertaken in accordance with all applicable State regulations.
- (8) Conduct periodic technical inspections of this dam on an annual basis.
- (9) Institute a definite plan for surveillance of the embankment during and after periods of heavy rain and/or runoff, and a warning system to notify people in downstream areas if an emergency occurs at the project.

JOHNSON CREEK DAM AT SALEM STREET

7.4 Alternatives. An alternative to implementing the measures listed above would be to remove all the stoplogs at the dam.

JOHNSON CREEK DAM AT SALEM STREET

APPENDIX A
PERIODIC INSPECTION CHECKLIST

JOHNSON CREEK DAM AT SALEM STREET

PERIODIC INSPECTION

PARTY ORGANIZATION

PROJECT JOHNSON CREEK DAM AT SALEM ST.

DATE April 16, 1979

TIME 12 - 4 P.M.

WEATHER Cloudy

W.S. ELEV. 73.8* U.S. 65.3* DN.S.

*Based on Established BM 80.1 at outlet of headwall, Washington St. Dam

PARTY:

- 1. Weber, R.
- 2. Branagan, L.
- 3. Checchi, W.
- 4. Nagel, S.
- 5. Sviokla, F.
- 6. Risitano, J.
- 7. _____
- 8. _____
- 9. _____
- 10. _____

	PROJECT FEATURE	INSPECTED BY	REMARKS
1.	<u>Dam</u>	<u>Weber</u>	
2.	<u>Spillway</u>	<u>Weber/Branagan</u>	
3.	_____	_____	_____
4.	_____	_____	_____
5.	_____	_____	_____
6.	_____	_____	_____
7.	_____	_____	_____
8.	_____	_____	_____
9.	_____	_____	_____
10.	_____	_____	_____

PERIODIC INSPECTION CHECK LIST

PROJECT Johnson Creek Dam DATE April 16, 1979
 PROJECT FEATURE Dam NAME R. Weber
 DISCIPLINE Geotechnical NAME _____

AREA EVALUATED	CONDITIONS
<u>DAM EMBANKMENT</u>	
Crest Elevation	Varies from 79.4 to 79.6
Current Pool Elevation	73.8
Maximum Impoundment to Date	Unknown
Surface Cracks	None visible
Pavement Condition	Fair some minor cracking
Movement or Settlement of Crest	None visible
Lateral Movement	None visible
Vertical Alignment	Verticle curve
Horizontal Alignment	Straight
Condition at Abutment and at Concrete Structures	Good - Ties into higher natural ground
Indications of Movement of Structural Items on Slopes	None visible
Trespassing on Slopes	Some foot traffic
Sloughing or Erosion of Slopes or Abutments	Upstream slope erosion
Rock Slope Protection - Riprap Failures	None present
Unusual Movement or Cracking at or near Toes	None visible
Unusual Embankment or Downstream Seepage	None visible
Piping or Boils	None visible
Foundation Drainage Features	Unknown
Toe Drains	Unknown
Instrumentation System	Unknown

PERIODIC INSPECTION CHECK LIST

PROJECT Johnson Creek Dam DATE April 16, 1979

PROJECT FEATURE Spillway NAME R. Weber/L. Branagan

DISCIPLINE Geotechnical/Hydraulics NAME _____

AREA EVALUATED	CONDITION
<u>OUTLET WORKS - TRANSITION AND CONDUIT</u>	
General Condition of Concrete	-----
Rust or Staining on Concrete	-----
Spalling	-----
Erosion or Cavitation	-----
Cracking	-----
Alignment of Monoliths	-----
Alignment of Joints	-----
Numbering of Monoliths	-----

The outlet conduit is constructed of corrugated metal pipe. The pipe did not appear to be coated. The horizontal angle of the pipe is skewed to the highway.

PERIODIC INSPECTION CHECK LIST

PROJECT Johnson Creek Dam

DATE April 16, 1979

PROJECT FEATURE Spillway

NAME R. Weber/L. Branagan

DISCIPLINE Geotechnical/Hydraulics

NAME _____

AREA EVALUATED	CONDITION
<u>OUTLET WORKS - SPILLWAY WEIR, APPROACH AND DISCHARGE CHANNELS</u>	
a. Approach Channel	
General Condition	Good
Loose Rock Overhanging Channel	None
Trees Overhanging Channel	Yes, some upstream
Floor of Approach Channel	Not visible
b. Weir and Training Walls	
General Condition of Concrete	Wood Stoplogs - concrete structure good condition
Rust or Staining	None visible
Spalling	None visible
Any Visible Reinforcing	None visible
Any Seepage or Efflorescence	None visible
Drain Holes	None visible
c. Discharge Channel	
General Condition	Good
Loose Rock Overhanging Channel	None
Trees Overhanging Channel	Yes, trees and brush, moderate
Floor of Channel	Gravel
Other Obstructions	Some minor debris but no obstructions

APPENDIX B

PLANS OF DAM AND PREVIOUS
INSPECTION REPORTS

	<u>Page</u>
Figure B-1 Plan of Dam from field survey on April 16, 1979	B-1
Figure B-2 Sections through Dam from field Survey on April 16, 1979	B-2
Figure B-3 Addition Details and Sections from field survey on April 16, 1979	B-3
Previous Inspection Reports by the Essex County Engineering Department:	
Report dated July 21, 1971	B-4
Report dated November 15, 1913	B-5
Notes from inspections on March 26, 1917 through January 25, 1968	B-6

JOHNSON CREEK DAM AT SALEM STREET

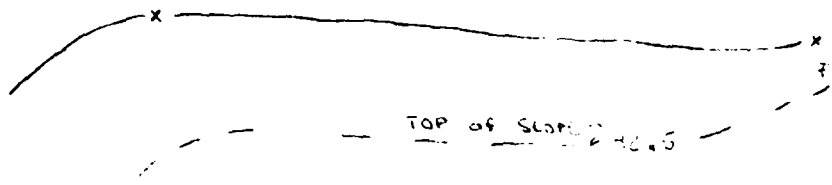
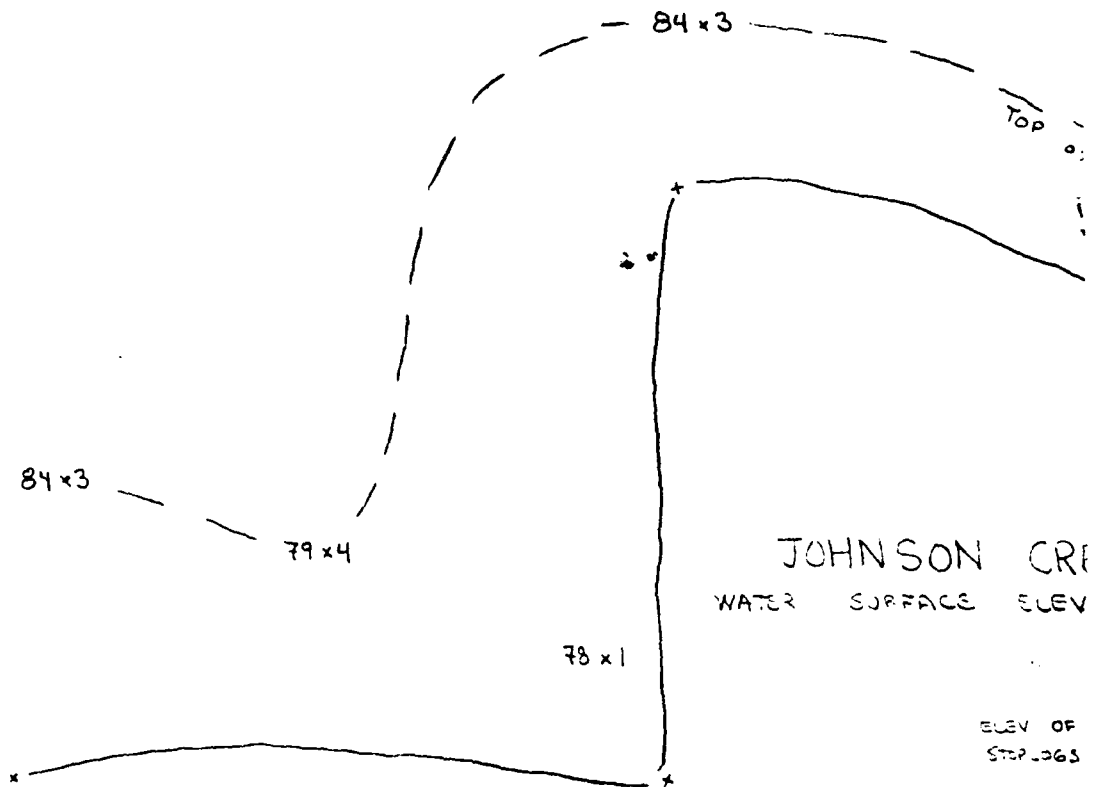

NOTES:

1. ELEVATIONS SHOWN BASED
ELEV: 2011 (MSL) SEE
2. INFORMATION SHOWN IS
3. ↗ DENOTES SEEPAGE
4. ↘ #2

METCALF & EDDY, INC.

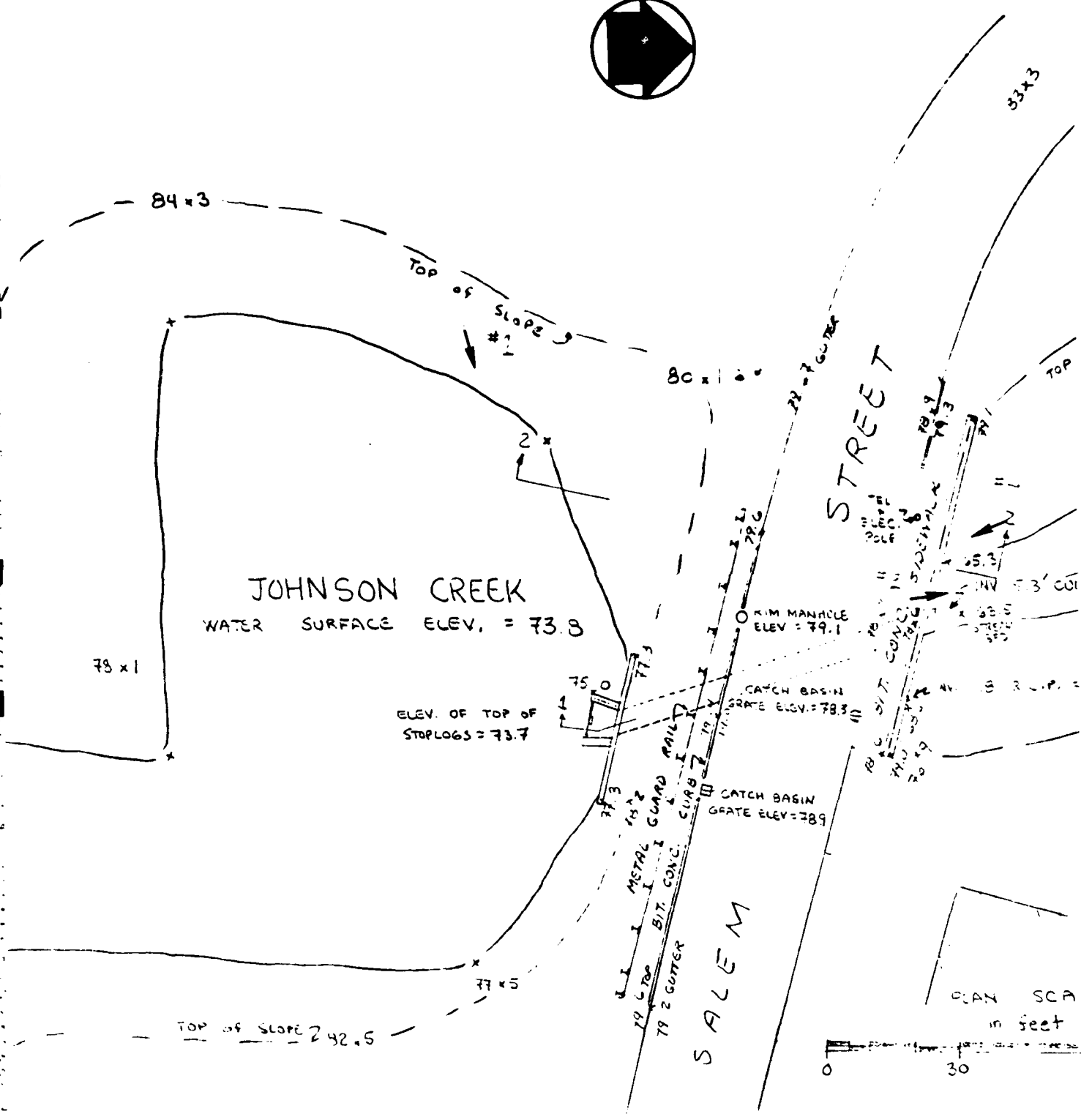
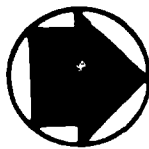

NOTES:

2

1. ELEVATIONS SHOWN BASED ON TOP OF OUTLET HEADWALL AT WASHINGTON ELEV. = 80.1 (MSL). SEE FIGURE B-3 FOR WASHINGTON ST. DETAILS.
2. INFORMATION SHOWN BASED ON FIELD SURVEY OF APRIL 16 1979.
3. A DENOTES SEEPAGE
4. #2 INDICATES LOCATION AND DIRECTION FLOW TO

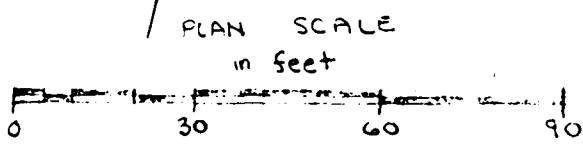
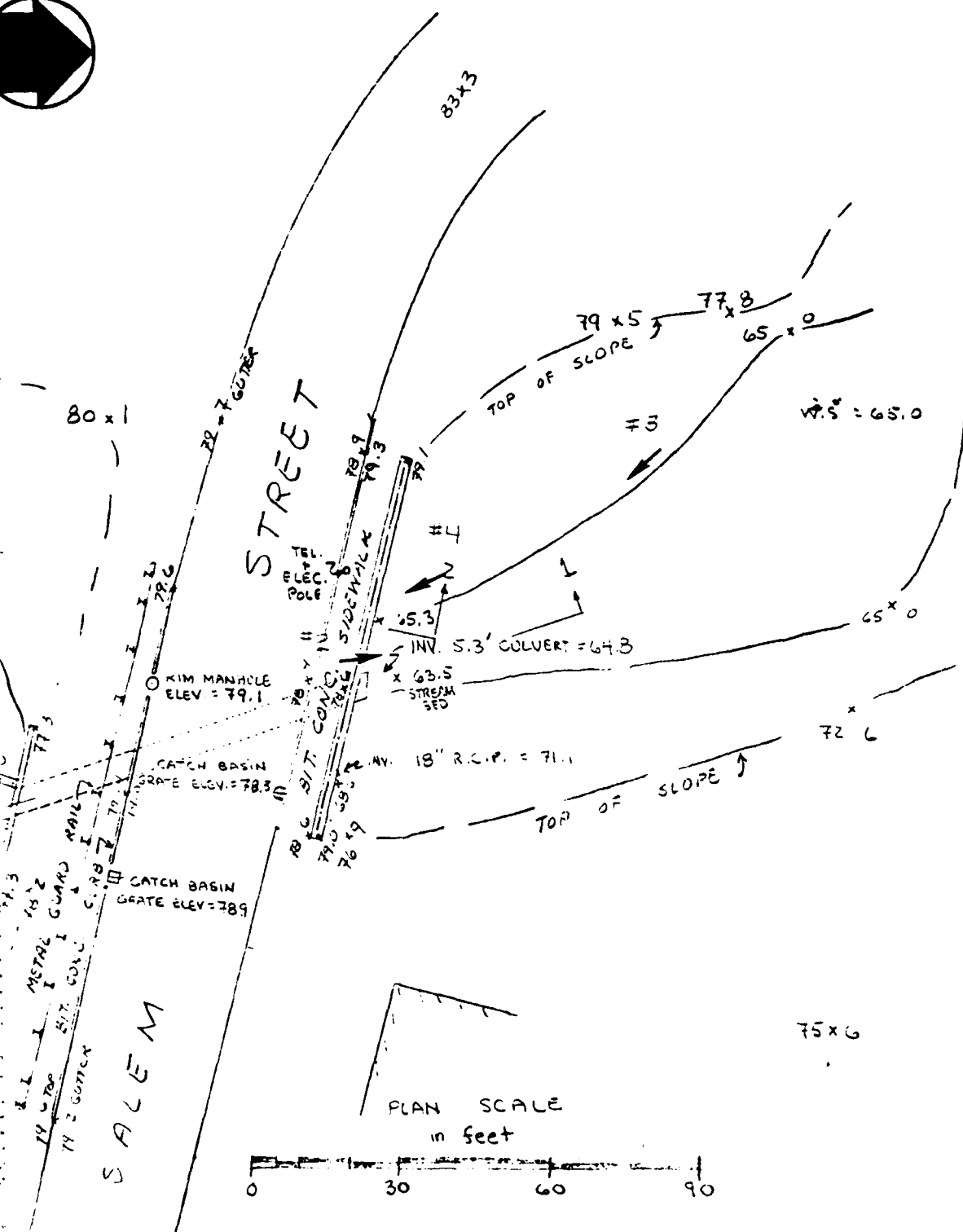
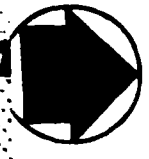

OF OUTLET HEADWALL AT WASHINGTON ST
E-3 FOR WASHINGTON ST. DETAILS.
FIELD SURVEY OF APRIL 16, 1979

3

DIRECTION OF VIEW FOR PHOTOGRAPHS

METCALF & EDDY, INC. ENGINEERS BOSTON, MA.	U.S. ARMY ENGINEER DIV. NEW ENGLAND CORPS OF ENGINEERS SALEM, MA.
NATIONAL PROGRAM OF INSPECTION OF NON-FED DAMS	
JOHNSON CREEK AT SALEM STREET	
FIGURE B-1 PLAN OF DAM	
TRIBUTARY MERRIMACK RIVER	MASSACHUSETTS

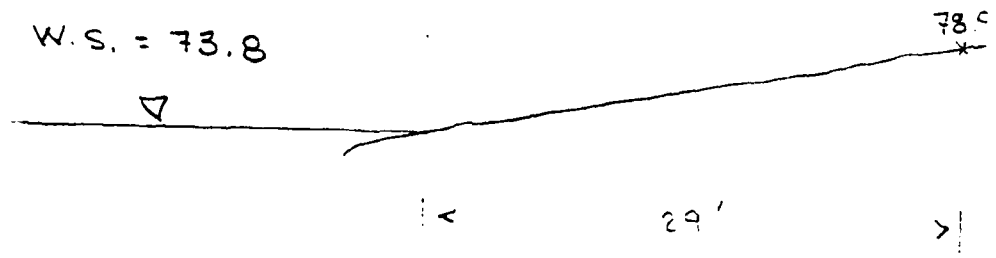
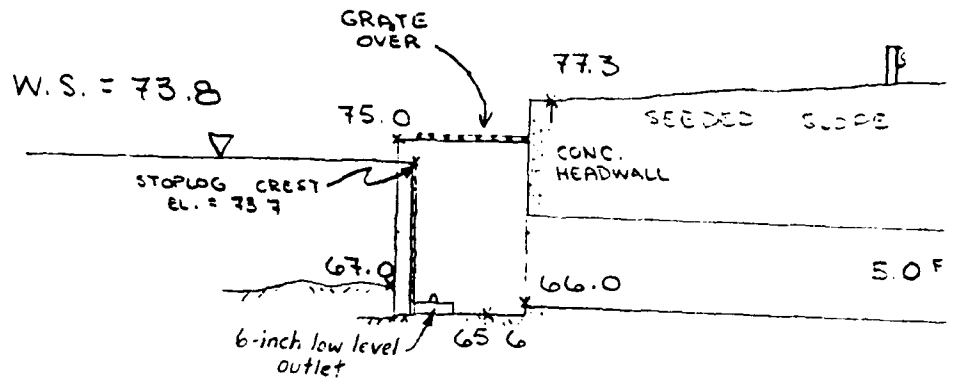

METCALF & EDDY, INC.

SALEM STREET

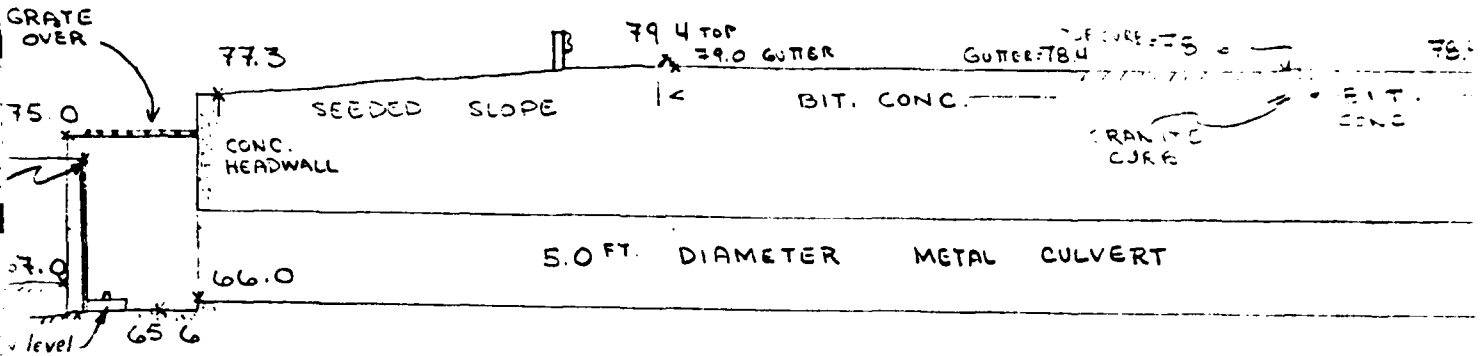

SECTION 1-1
OUTLET STRUCTURE

SALEM STREET

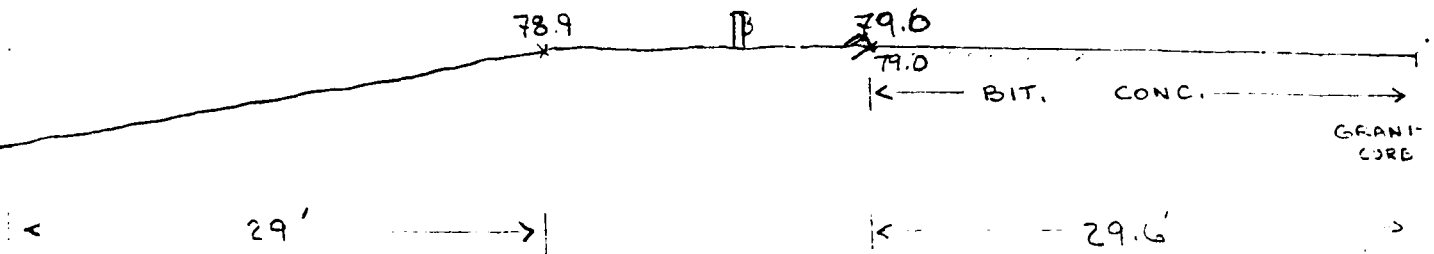

SECTION 2-2
RIGHT ANGLE SECTION
THROUGH ROADWAY

SECTION SCALE
in feet

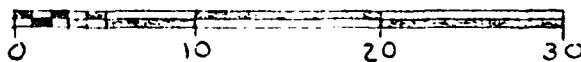

A STREET

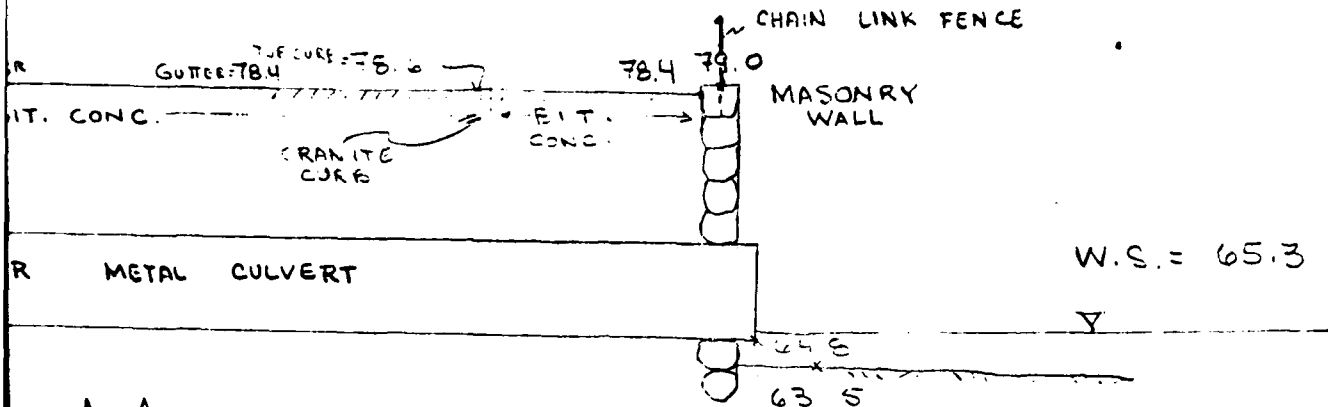

1-1

STRUCTURE

SALEM STREET

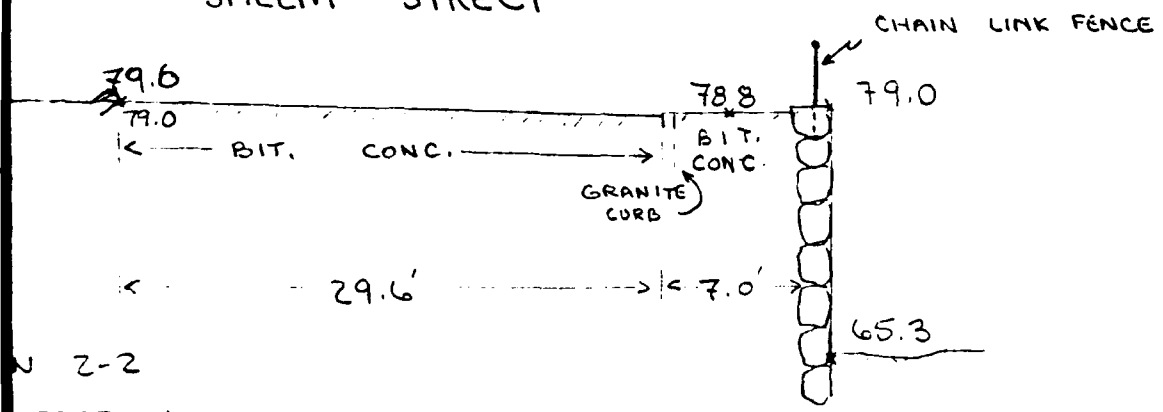

2-2

SECTION
ROADWAY

ON SCALE

FEET

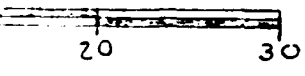

METCALF & EDDY, INC.	U.S. ARMY ENGINEER DISTRICT HEADQUARTERS
ENGINEERS	CORPS OF ENGINEERS
BOSTON, MA.	SALEM, MA.
NATIONAL PROGRAM OF INSPECTION OF NON-FED DAMS	
JOHNSON CREEK AT SALEM STREET	
FIGURE B-2 SECTIONS THROUGH DAM	
TRIBUTARY MISSISSIPPI RIVER	

3

JOHNSON POND
 WATER SURFACE ELEV. = 75.2

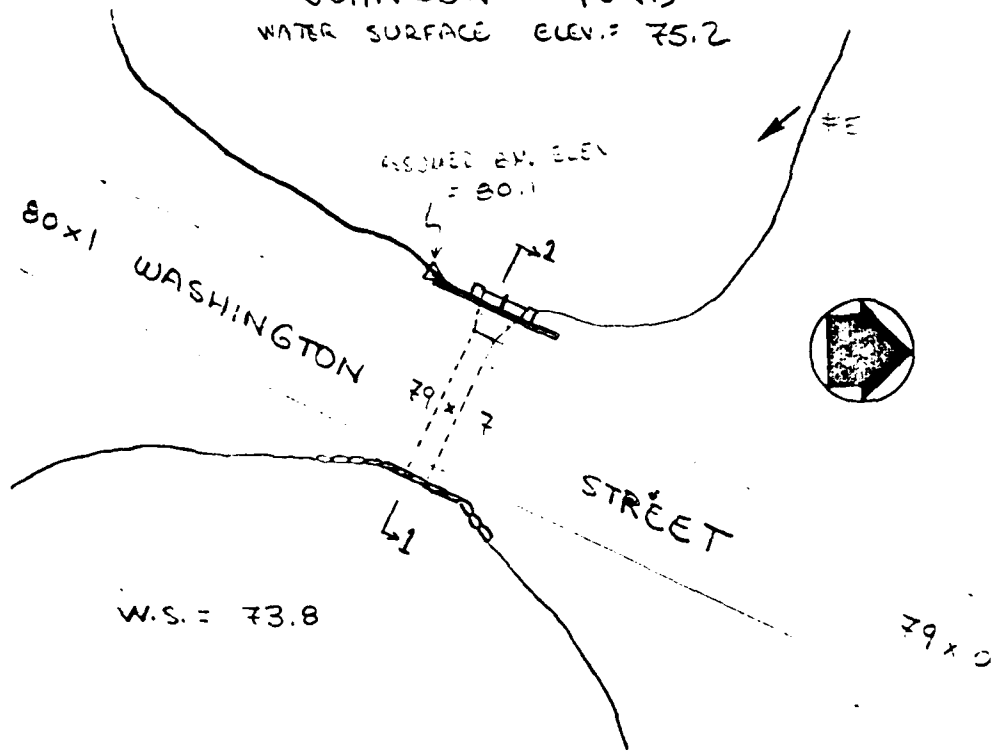

W.S. = 73.8

PLAN SCALE
 in feet

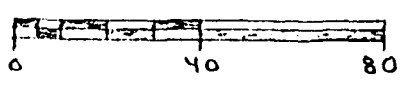

↓ #6
 [Symbol]

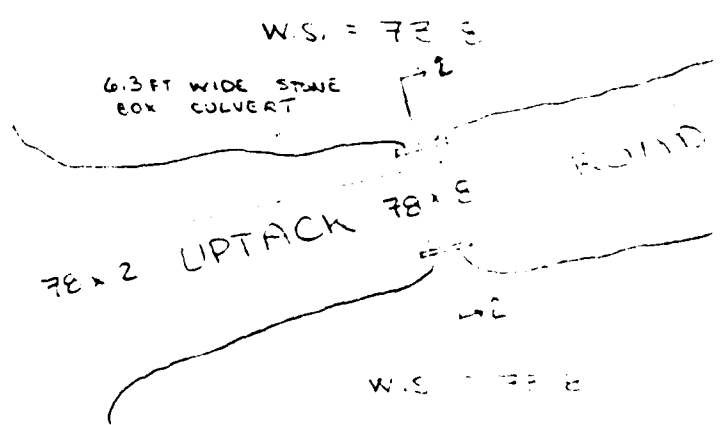

W.S. = 73.8

6.3 FT WIDE SPWEE
 BOX CULVERT

78x2 UPTACK 78x2

W.S. = 73.8

78.4

DOWN POND
 ELEV. = 75.2

EXIST. ELEV.
 = 80.1

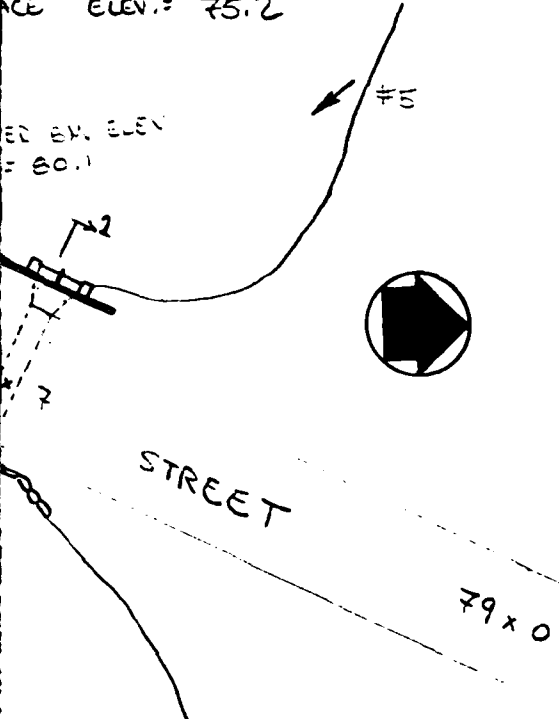

PLAN SCALE
 in feet

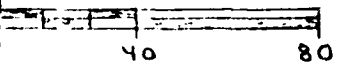

#6
 [Taken from Washington Street]

WASHINGTON

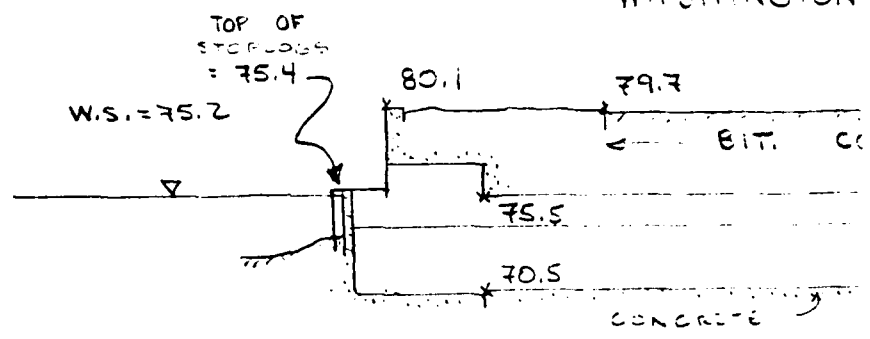

SECTION
 METAL CULVERT

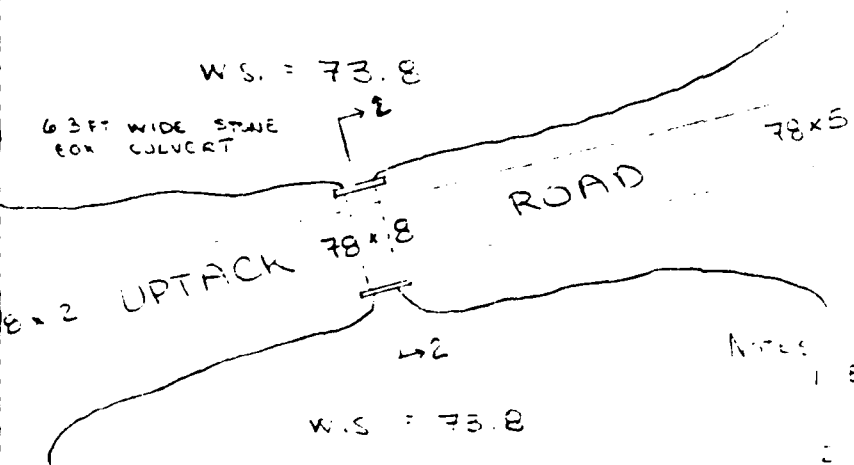

NOTES

- ELEVATIONS SHOWN ARE AT THE TOP OF THE STRUCTURE AT WASHINGTON STREET.
- FE INDICATES LOCATION AND VIEW FOR PHOTOGRAPH.

2

WASHINGTON ST.

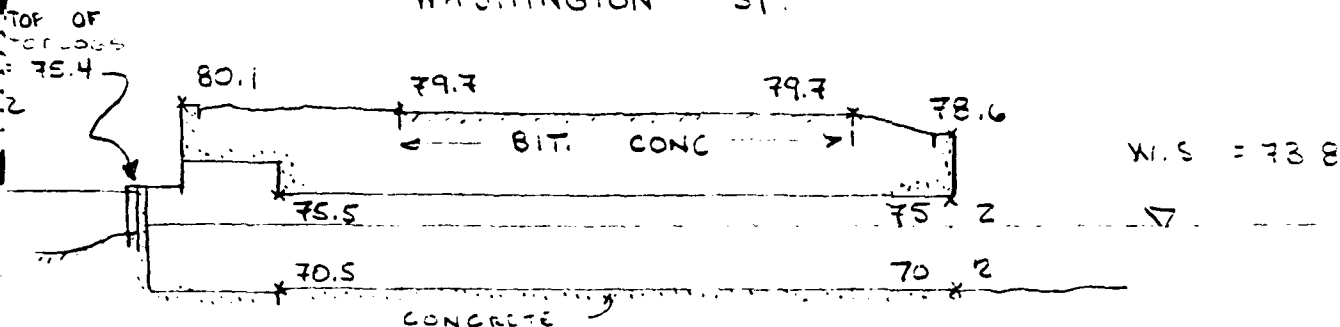

SECTION 1-1
METAL CULVERT (5FT DIAMETER)

SECTION SCALE
in feet

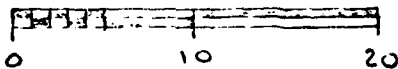

UPTACK RD.

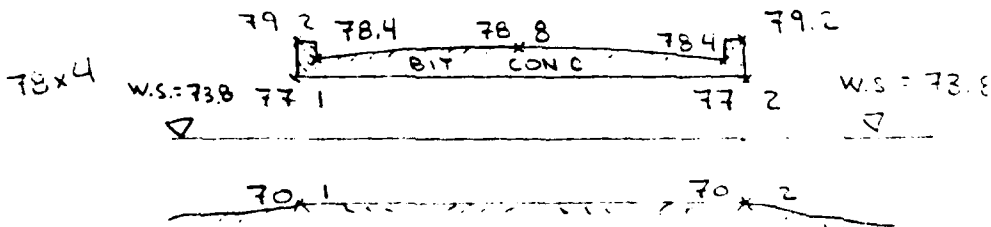

SECTION 2-2

BOX CULVERT AT UPTACK ROAD
[6.3 FT WIDE]

ELEVATIONS SHOWN BASED ON TOP OF OUTLET HEADWALL AT INTERSECTION OF UPTACK RD. (M.S.D.)

↖ INDICATES LOCATION AND DIRECTION OF VIEW FOR PHOTOGRAPHING

3

METCALF & EDDY, INC. ENGINEERS BOSTON, MA.	U.S. ARMY ENGINEER DIV. NEW ENGLAND CORPS OF ENGINEERS BOSTON, MA.
NATIONAL PROGRAM OF INSPECTION OF NON FED. DAMS	
JOHNSON CREEK AT SALEM STREET	
FIGURE B-2 ADDITIONAL DETAILS AND SECTIONS	
TRIBUTARY MERRIMACK RIVER	MANHATTAN SETS

D 6
GROVELAND
5-5-116-6

L.E. WILKINSON 7/21/71

BEGIN ON ROUTE 97 AT SALEM ST. TAKE SALEM ST. WEST.

HI. DAM IS ROADWAY AT THIS POINT WITH SPILLWAY AT SOUTH SIDE OF ROAD.

TOWN OF GROVELAND

EARTH WITH STONE MASONRY WALL NORTH SIDE (DOWNSTREAM) AND NEW CONC. WALL UPSTREAM. PAVED ROADWAY SURFACE ON TOP OF DAM.

18.0± FT.

70.0± FT.

WATER LEVEL 5.0 FT. BELOW LATERAL WALL OVER OLD PENSTOCK OUTLET. FLASHBOARDS IN PLACE WITHIN 7" OF TOP OF SPILLWAY WING WALLS. WATER LEAKING THROUGH BETWEEN FLASH BOARDS ABOUT HALF WAY UP FROM BOTTOM. DEBRIS IN ENTRANCE TO PENSTOCK PIPE. CONC. O.K.

DEBRIS (BOARDS & LOGS) SHOULD BE REMOVED FROM STILLING BASIN UNDER GRILL AT ENTRANCE TO PENSTOCK. OUTLET AT DOWNSTREAM END OF PIPE SHOULD BE PAVED AND SIDE SLOPES RIP RAPPED AS RETAINING WALL DOWNSTREAM FACE OF DAM IS BEING UNDERMINED.

COUNTY OF ESSEX, MASSACHUSETTS
ENGINEERING DEPARTMENT

Inspection of Dams, Reservoirs, and Stand Pipes

O 1095
SUB NUMBER
D. 6. R. S. P
Neg. No. 1166-

Inspector *C. Barker* Date *Nov. 15, 1913* *Classification *1*

City or Town *Groveland* Location *Outlet of Johnson's Pond on Salem Street*

Owner *Groveland Mills* Use *Mill Power*
Include such details as core, cut off walls, paving, sodding, class of masonry, kind of cement, (nat. or port.) etc.

Material and Type *Dam is formed by the street (a new wall was put in with the st. was widened)*

Elevations in feet: above (+) or below (-) full pond or reservoir level. (Cross out what does not apply.)
For Dam
Bed of stream below *-1.9* Bottom of pond *-7* Bottom of spillway *-9* Top of dam *0* Top of flash boards
For Res. or S. P.
Ground surface below Bottom of res. Level of over flow pipe Top of res.

Length in ft. Top width in ft. *4'* Pond area *32' area* Area of watershed *5 1/2 sq mi.*

For Res. or S. P.
Inside dimensions Capacity covered open

Length of overflow or spillway *750* Outlet pipes (size and nature) *2"*

Stand pipe, thickness at base diam. of rivet head *1/2"* Pitch *1/2"*

Foundation and details of construction

Constructed by and date

Recent repairs and date

Evidence of leakage

Condition *Good* S. P. when painted *inside*

Topography of country below *Narrow valley & other dams*

Nature, extent, proximity, etc. of buildings, roads or other property in danger if failure should occur. *Road in all*

property would be damaged.

Plans and data secured or available

Use separate sheet for sketches if necessary.
Notes, sketches, sections, etc. *Max head on wheel is 18 ft.*

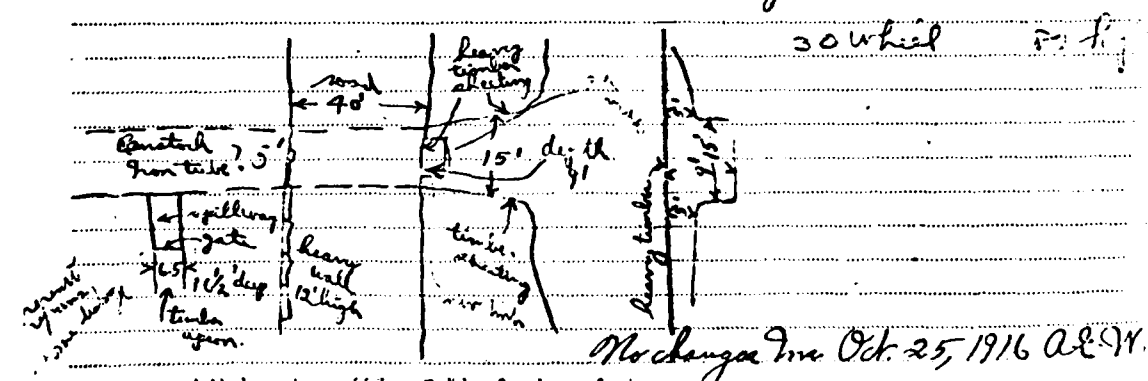

*Classify as to probable damage in case of failure. 1 slight. 2 moderate. 3 serious.

Groveland D. 6

1917, March 26. Watershed 5.0 sq. m. Max. Ht. 10.0 ft. Apparent condition, Good.

1917, June 16. Report on failure of Groveland Dam #6. A. E. Woodbury, Insp. Mr. Evans and I looked at the dam, etc. at Salem St., Groveland. Nothing had been done since the time it went out June, 1917, at 4: A. M., except to prop up the car tracks. Some sand bags had been placed near the break, but did no good as they were put there too late. The probable cause of the failure was the caving in of the culvert directly back of the timber sheeting and the pond being full started to wash around the west end and down in the culvert. Before the pond emptied it had washed a hole about 20' in diam. directly back of the timber sheeting. No serious damage was done as the water flowed thru the culvert and into the pond below.

June 19, 1917. Took some pictures, nothing started as yet, some lumber piled up near there, they are probably going to repair it soon.

June 25, 1917. Mr. Evans talked with Mr. Veasey of the Mills. The culvert was repaired with railroad irons and concrete, the timber sheeting has been renewed from the west end to the culvert and the back fill is going on at present. Pond is still empty.

1925, Nov. 4. R. R. Evans, Insp. with Mr. A. H. Veasey. This dam was extensively repaired in 1917 and inspected by this department at the time. It apparently is in good condition.

1925 Report to Co. Comm. Same as above.

1929, Nov. 14. C. C. Barker, Insp. At Salem St. on the outlet of Johnson's Pond, owned by Groveland Mills, was formerly used for power. In case of failure, the road, which is part of the dam, would be damaged and probably the mill property. Below the dam the valley is narrow. The conditions are the same as at the last inspection. Some repairs have recently been made around the spillway gate by putting in new timbers, also on the upper side of the dam next the outlet to the flume on the west side, to stop the water from going underneath into an old culvert under the roadway.

1929 Report to Co. Comm. The dam is apparently in good condition and some minor repairs have been recently made.

1931, Oct. 8. C. C. Barker, Insp. Dam is not in use now. The gate to the flume is open. The timber work along the upper side is in poor condition. There is not any water in the pond. The conditions are the same and there have been no changes since the last inspection.

1931 Report to Co. Comm. Some of the timber work is in poor condition. The gate to the flume is open.

1933, Sept. 11. C. C. Barker, Insp. This dam is in poor shape. The timber gate and sheeting on the upper side is very bad and falling apart. I did not see the owners, but saw the watchman who was sawing out the stop plank in the flume box below the dam, so that no water would be held back, but should have a free course. The watchman is supposed to keep the spillways clear and allow the water to have a free course. The conditions are the same. Mr. Veasey's office is open only on Wednesdays.

1933 Notes by R. R. Evans (Not in report to Co. Comm.) The dam belonging to the Groveland Mills on the stream flowing from Johnson's Pond still remains out of use. Conditions at this dam were discussed in my report to you at the time of the last inspection (1931) and since that time the timber portion of this dam has deteriorated rapidly as then anticipated. With the outlet open as at present the structure is apparently safe even if in poor condition, but this safety depends upon the vigilance of the watchman (who I understand is charged with that duty) in keeping these outlets open and preventing obstruction by the old timber or otherwise.

1935 Sept. 23, C. C. Barker, Insp. A short time ago the timber sheet on the upper side of this dam was repaired and put in good shape. The dam is in much better condition than when last inspected. I did not see the owners. There is no water in the pond today.

1935 Report to Co. Comm. Conditions on the stream leading from Johnson's Pond are somewhat improved since my last report. The dam on the south side of Salem Street was repaired during the past year with new timbers and seems to be in good condition. As maintained at present it holds back practically no water.

1937 July 21, C.C.Barker, Insp. I did not see the owners. The conditions here are the same, and there is no water in the pond today. The timber work on upper side of dam is fairly good.

1937 Report to Co. Comm. Safe and in reasonably good condition.

1939 Sept. 1, C.C.Barker, Insp. The conditions here are rather poor. The outlet is somewhat blocked with debris. There is a little water in the pond. The timber in the old flume box on the down stream side of the dam is in poor condition, falling apart and might block the passage way.

1939 Report to Co. Comm. There are three dams on the outlet from Johnson's Pond, one at Salem Street and two between Salem Street and Main Street near its junction with Washington Street. At Salem Street the conditions are not as good as when last reported since the timber work is in rather bad condition and there is again some danger that the outlet under the street might be clogged in times of flood although the pond is normally drained off, as the gate is open.

1941 Sept. 30, C.C.Barker, Insp. The earth embankment of this dam which forms the highway is in fair condition, but the timber at the entrance to the flume and the overflow or spillway is in very poor shape and might block the passageway. There has not been any change here. The pond is dry today.

1941 Report to Co. Comm. On this same stream flowing from Johnson's Pond, at Salem Street, which formerly was utilized as a part of a dam, the timber outlet works are in bad shape and could block the outlet, which is now normally open, and cause damage probably of no great extent.

1943 Aug. 25, S.W.Woodbury, Insp. I did not see the owner. Conditions here are apparently the same. The timber construction south of Salem Street does not look bad. The wooden trash rack is still in place, but the old gate has been removed. The timber work north of Salem Street, around the old penstock, has collapsed and is in a pile at the outlet. About 2" of water is running out of the pipe today. No water is running through the culvert under Salem Street, but it looks as if there is a lot of water here during the wet season.

1943 Report to Co. Comm. At the old dams on the stream from Johnson's Pond, including the one at Salem Street and those between Salem Street and Washington Street, the same condition exists as in the past few years since the mills have been demolished. The old timber work is very much deteriorated and there is a possibility that the outlets may become blocked and cause the ponds to fill and overflow the dams, causing a failure and possible damage. These outlets should be cleared of all debris to prevent a dangerous condition, as there is not proper supervision over these old dams.

1945 Aug. 24, S. W. Woodbury, Insp. I left a copy of the notice for Mr. Veasey with his gardener at 5 Windsor Street and went to the dam alone. Condition of the dam is the same. Part of the old trash rack is broken off and debris around outlet holds back some water.

1945 Report to Co. Comm. See D. 2

1947 Sept. 18, S.W. Woodbury, Insp. Went to dam alone. No repairs since last inspection. Conditions below the dam are the same. Water level today: about 2" of water in penstock. The trash rack at the south side has gone to pieces and partly blocks the opening. I gave a copy of the notice to Mr. Veasey. He says that he does not own any of the dams at South Groveland now. The property on the north side of Salem Street is bounded by Salem St. but the property on the south side of Salem St., is bounded by the high water line of the pond and I cannot find any record to show that Mr. Veasey has relinquished any of his rights of flowage, etc.

1947 Report to Co. Comm. See D. 2

1949 Sept. 19, S.W. Woodbury, Insp. Went to dam alone. No repairs since last inspection. Conditions below the dam the same. Water level today: About 2" of water in penstock. Old trash rack is gone now.

1949 Report to Co. Comm. See D. 2.

1951 Oct. 18, E.H. Page, Insp. Went to dam alone. Water level today: 5" of water in penstock. Leaks: Some seepage. A lot of debris piled up at the entrance to the penstock. Some wood in penstock at old gate.

1951 Report to Co. Comm. The dam on the south side of Salem Street is in poor condition. Much debris is piled against the outlets which should be kept clear to allow free passage of the water since the dam is apparently not in use now.

1953 Oct. 1, E.H. Page, Insp. Went to dam alone. Water level today: 2" or 3" of water in old penstock. Leaks: Seeping through the old brick arch at the old draw-off gate. The old timberwork is very rotten and falling apart and is apt to give away anytime and block up the outlet. Much debris in front of old penstock and inside it. There is no trash rack here.

1953 Report to Co. Comm. The dam at the stream from Johnson's Pond at Salem Street is formed by the road. The timber bulkhead on the upstream side is very rotten and falling apart and is apt to give way at any time and block the outlet. There is much debris both in front and inside of the old penstock which should be cleaned out. There are no trash racks.

1955, Nov. 22, E.H. Page, Insp. Elev. of water: 4 1/2" over flashboards. 2 1/2" over conc. side walls of box inlet. Minimum freeboard: 2'-4". The old steel penstock has been blocked off and the water now runs through

a new 60" steel corrugated pipe. A conc. box was built in front of the new conc. headwall for stop planks. Steel trash rack has been bolted on top of conc. wall. There is a 2" x 8" plank running down each side of the conc. buttress and it appears that the stop planks are spiked to it. The height of these flashboards is only about one foot lower than the flashboards at Johnson's Pond outlet. These flashboards are too high to allow for flood waters

1956, April 24, E.H. Page & J.O. Harmaala, Insp. Elev. of water: 8" over flashboards and 2" below top of conc. inlet. One 8" flashboard has been removed since the notice was sent to the town. Evidence that the water has been 18"± higher than it is now. Some erosion around end of wall when the water was up high.

1955 Report to Co. Comm. The dam on the stream from Johnson's Pond, at Salem Street, is formed by the road. A new sixty inch corrugated metal pipe was put in here this year. The old timber bulkhead was replaced by a reinforced concrete retaining wall. Concrete wing walls and provisions for flashboards were constructed in front of the opening of the sixty inch pipe. This forms sort of a drop inlet. The opening in the old steel penstock has been blocked off. Flashboards have been put in right up to the top of the concrete wingwalls. These planks have all been spiked to a 2" x 8" plank. This would make the boards act as a one-piece gate. It would be almost impossible to remove this gate at high water. The planks should be removable individually. Some of the planks should be removed now, as there is now no allowance for flood waters. A steel trash rack has been placed over the top of the opening of the drop inlet. The height of the flashboards, as they are now, is one foot lower than the Johnson's Pond outlet.

1957, Dec. 4, E.H. Page, Insp. Elev. of water: 2'-7" below top of spillway wingwall. Height of flashboards: 8 ft ±. No obstructions in spillway. Condition: Good. The top three planks can be removed individually about 15" although they fit very tight in the slots. The rest of the planks are spiked together. The smell of natural gas is very noticeable.

1957 Report to Co. Comm. The dam on the stream from Johnson's pond is in fair condition, but the stopplanks cannot be removed at high water. This condition should be remedied.

1958, Jan. 28, E.H. Page & A.A., Insp. Elev. of water: 0.3 over flashboards. Not very much water.

1959, Sept. 22, E.H. Page, Insp. Elev. of water: Water at top of flashboards. Height of flashboards: Within 6" of top of conc. inlet box. Condition: Same.

1959 Report to Co. Comm. The dam on the stream from Johnson's Pond at Salem Street is in fair condition, but the stop planks cannot be removed at high water. This condition should be remedied.

Groveland D. 6

D. 6 Sh. 5 ..

1961, Dec. 4, E.H.P. Insp. Elev. of water: 1" over flashboards.
Height of flashboards: 8" from top of conc. Some obstructions in
spillway. Erosion of banks around s.e. end of conc. wall.

1961 Report to Co. Comm. Dam on the stream from Johnson's Pond at
Salem Street is in fair condition, but the stopplanks cannot be
removed at high water. This condition should be remedied. There is
some erosion of the banks around the southeasterly end of the concrete
wall.

1964, Feb. 14, P.D.K. & K.M.J. Insp. No repairs. Elev. of water:
6" F.B. 2'-3" down. Erosion of banks: Same as last report. Small
tree should be removed.

1963 Report to Co. Comm. Dam on the stream from Johnson's Pond at
Salem Street is in fair condition, but the stop planks cannot be removed
at high water. This condition should be remedied. There is some
erosion of the banks around the southeasterly end of the concrete wall.
Small trees should be removed.

1965 June 14, 1966. P.D.K. Insp. Condition same as at 1963 inspection.

1965 Report to Co. Comm. Safe and in reasonably good condition.

1967 Jan. 25, 1968. P.D.K. Insp. Safe and reasonable condition.

1967 Report to Co. Comm. Safe and in reasonably good condition.

APPENDIX C

PHOTOGRAPHS

(For location and direction of view of photographs, see Figures B-1 and B-3).

JOHNSON CREEK DAM AT SALEM STREET



NO. 1 UPSTREAM FACE AND OUTLET

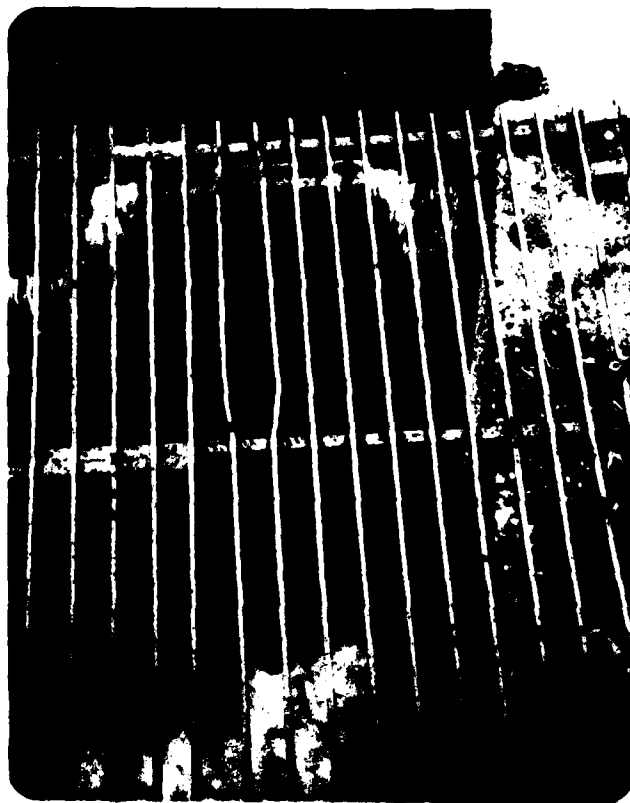

NO. 2 WATER DISCHARGING OVER STOPLOGS

JOHNSON CREEK at SALEM STREET



NO. 3 DISCHARGE CONDUIT AND DOWNSTREAM WALL

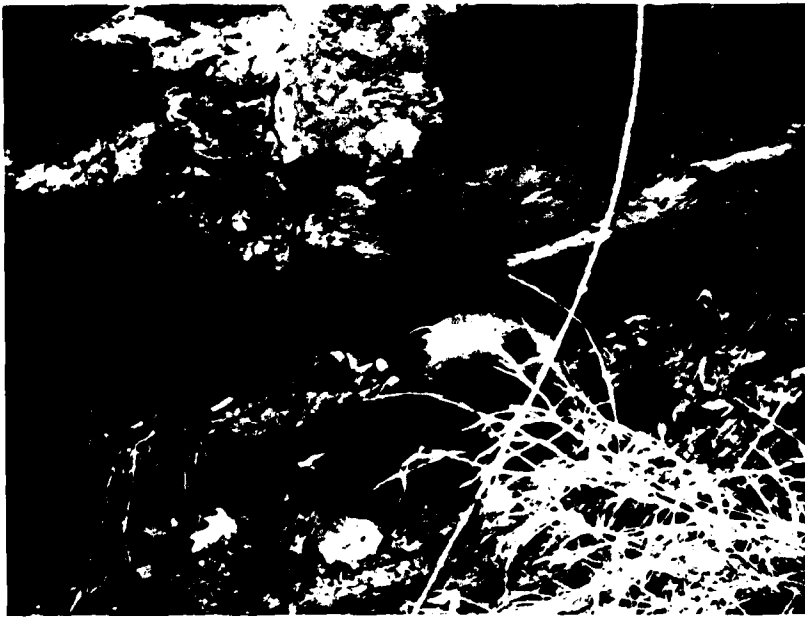

NO. 4 BLOCKS MISSING IN DOWNSTREAM WALL

JOHNSON CREEK at SALEM STREET



NO. 5 CONDUIT AT UPTACK ROAD

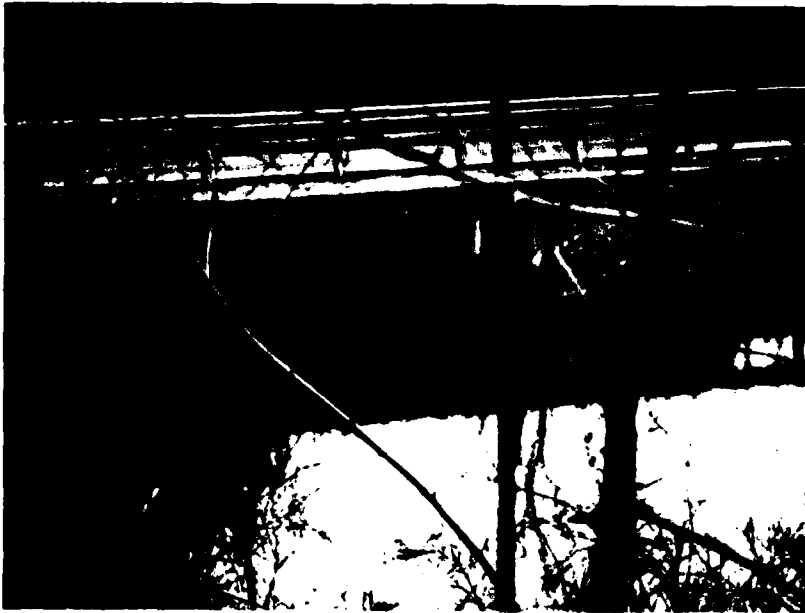

NO. 6 OUTLET AT WASHINGTON STREET

JOHNSON CREEK at SALEM STREET

APPENDIX D
HYDROLOGIC AND HYDRAULIC
COMPUTATIONS

	<u>Page</u>
Figure D-1 Drainage Area Map	D-1
Hydrologic/Hydraulic Computations	D-2

JOHNSON CREEK DAM AT SALEM STREET

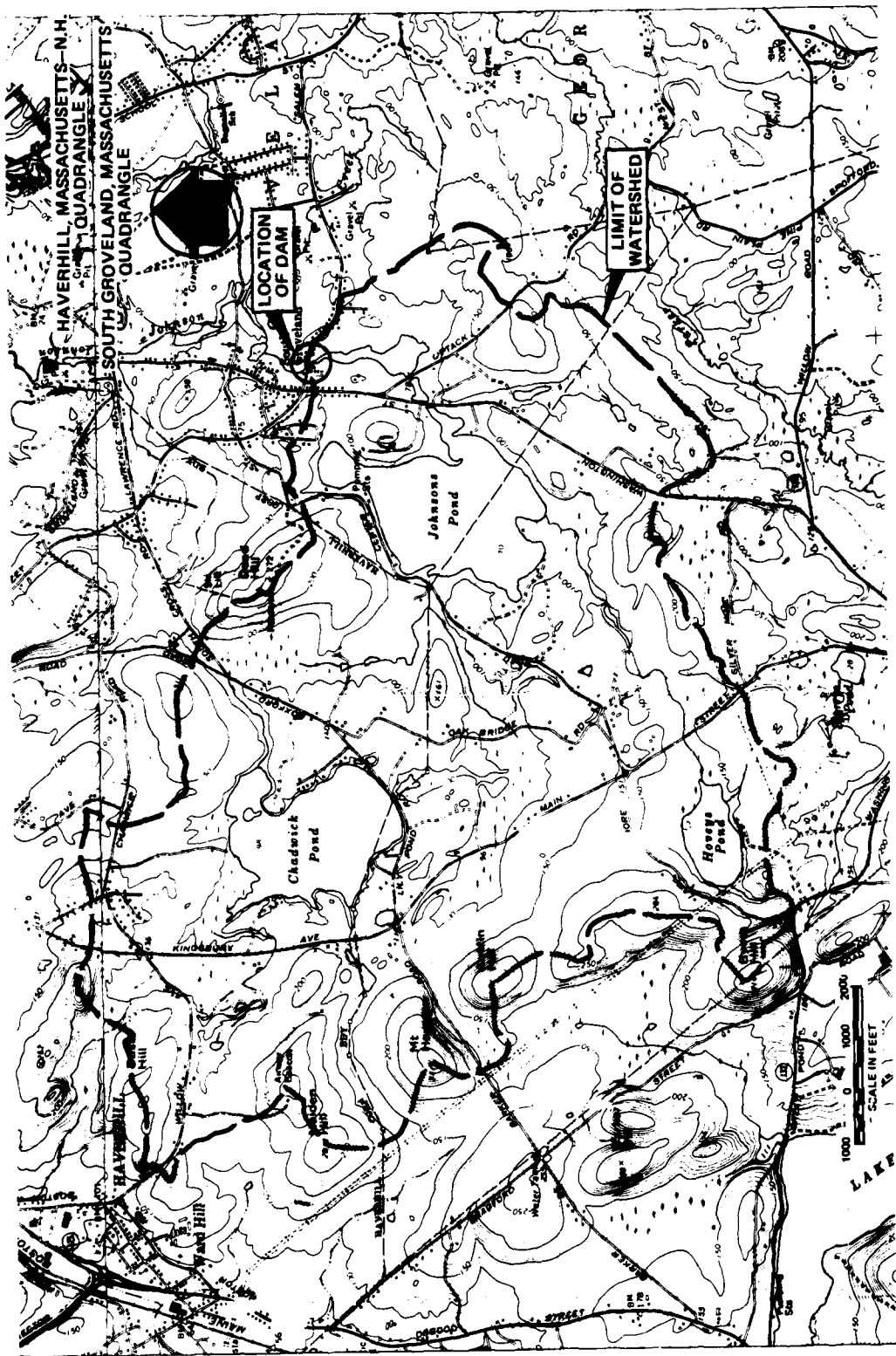

DRAINAGE AREA MAP - JOHNSON CREEK AT SALEM ST.

I Test Flood, Storage & Storage Functions

1- Total Drainage Area - 5.30 mi²

2- Pond(s) Area: $0.22 + .06 = 0.28$
 Swamp(s) Area: $.04 + .06 + .05 + .02 + .02 = 0.19$
Total Area Pond(s) & Swamp(s): 0.47

% Ponds & Swamps = $\frac{0.47}{5.30} = 8.9\%$

3- $\frac{316-70}{11800} = 2.07\%$; $\frac{311-70}{17600} = 1.36\%$ } Say Ave Slope = 2%

4- Using C. of E. Curves for Peak Flow Rates & above guide values the Peak Flow Rate was estimated to be between Rolling and Flat & Coastal, and taken at 1350 c.f.s./mi²
 Size Class: Interm. ; Hazard Pat.: Signif. ; Spill. Des. Flood: $\frac{1}{2}$ to Full PMF
 Use: Test Flood = $\frac{1}{2}$ Full PMF

5- Test Flood Inflow = $\frac{1}{2} (1350) 5.30 = 3570$ c.f.s.

6- Pond Storage

The pond area is 0.31 sq. mi. at elev. 73.7
 Based on a const. area, storage increases at 197.7 ac. feet per foot of depth increase.

7- Spillway crest elev. is 73.7 - with stoplogs in.

8- Storage Functions are based on $Q_{out} = Q_{in} [1 - \frac{S_{out}}{R}]$

S_{out} = Storage Vol. in Reservoir related to final Q_{out} in terms of inches of rain over the drainage area.

S (in Inches) = $12 D \left(\frac{0.31}{5.30} \right) = 0.70 D$; $R = 6$ hr rain of storm.

D = Storage depth in feet above spillway crest in reservoir

9- Storage Functions: (Test Flood & $\frac{1}{2}$ PMF - if needed)

$F_{TF} = 3578$	$- 376.6 S$	$= 3578 - 263.6 D$
$F_{\frac{1}{2}PMF} = F_{TF}$		$S = D$

II Discharge Relations

A. Main Conduit

Size 60 in ϕ , length 20' \pm , inlet controlled by structure with stoplogs, weir and horiz. grating.

1 - Inlet Structure

- Q_1 \rightarrow Weir - use "Hydr. Tables" - Williams & Hazen - length $\approx 28'$; el. 73.7
- Q_2 \rightarrow Grating - use orifice eq. $Q = 0.5 A \sqrt{2gh}$ & $A = 6 \times 6.0 \times 0.4 \approx 16 ft^2$
- Q \rightarrow For Pond El. over 75.5' \pm replace weir flow with orifice flow $Q = 0.5 A \sqrt{2gh}$ & $A \approx 8 \times 1.3 \approx 10 ft^2$

Pond El.	74	75	76	77	78	79	80	81	82	83	84	
$[Q_1 = 40 \sqrt{h}]$	Q_1	5'	40'	50	70	80	90	100	130	110	120	120
$[Q_2 = 64 \sqrt{h}]$	Q_2	-	-	60	90	110	130	140	160	170	180	190
ΣQ	5	40	110	160	190	220	240	260	280	300	310	

2 - Pipe Inlet Control - with Stoplogs Removed

Ref.: V.T. Chow - Fig 17-30

H/d	0.8	1.0	1.25	1.5	2.0	3.0	} $Q = 99.0 \sqrt{H} (C = 0.633)$
Q	90	130	170	220	270	350	
Pond El.	70	71	72.3	73.5	76	81	

Note: Inlet Structure controls over range of pond levels shown when stoplogs are in., but Pipe Inlet controls w/ stoplogs out

B - Crest Flow

Effective Low Pt. - El. 79.4 @ Top of curb south of Salem St.
 $\pm 40'$ @ 79.4, $\pm 130'$ @ 79.6 (includ. allow for el. beyond curb)
 Use "Hydr. Tables" - Williams & Hazen

Pond El.	80	81	82	83	84
Q_1	60	280	560	900	1300
Q_2	110	710	1590	2680	3950
ΣQ	170	990	2150	3580	5250

III Discharge, Storage & Storage Function vs Pond Elevation

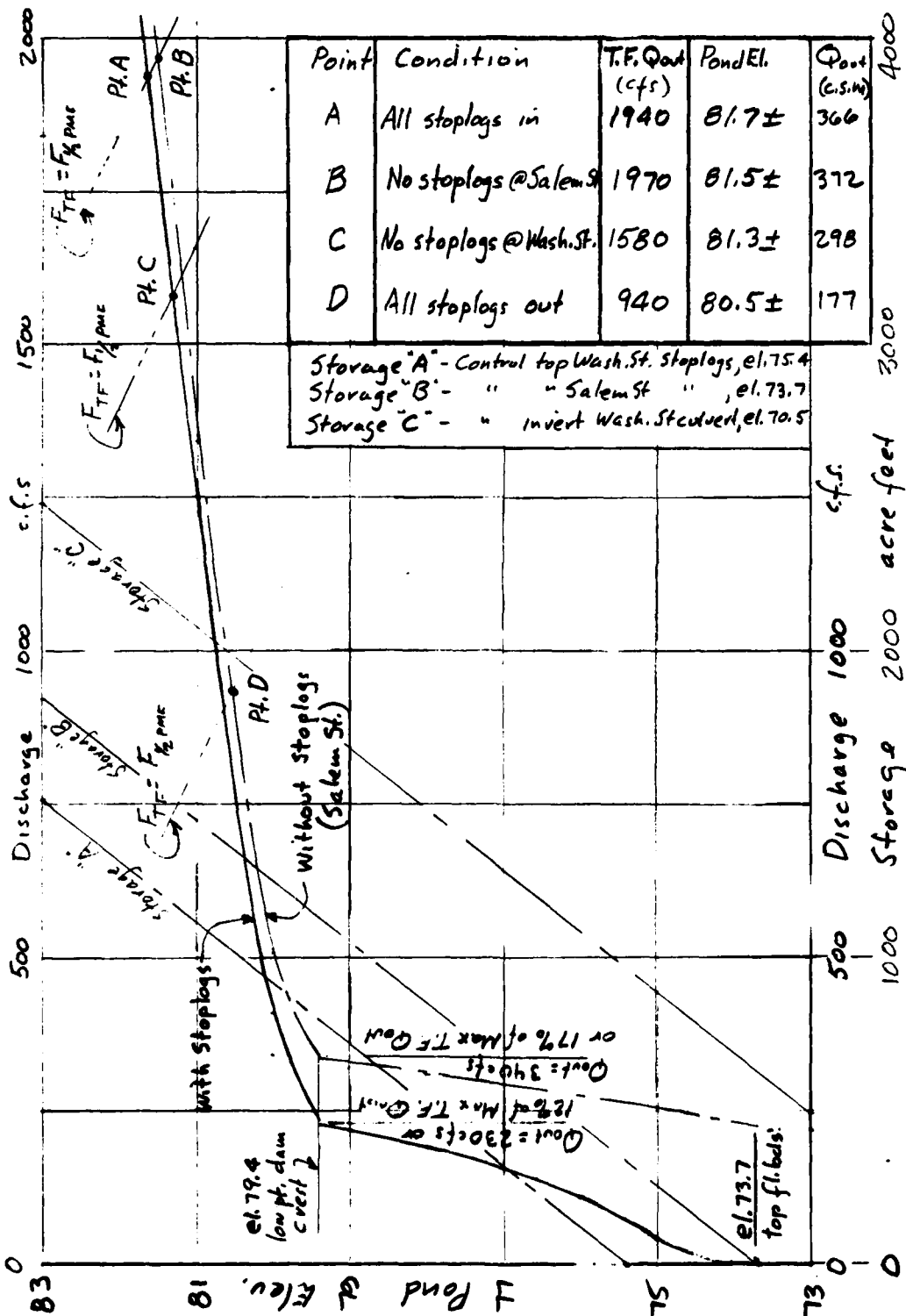

IV Crest Discharge Characteristics

Test Flood Pond El. 81.7
 Effect. L.P. Crest 79.4
 Max. Depth 2.3 ft.

$$z = 2.55(2.3)^{1.5} = 8.89 \text{ cfs.}$$

Critical Depth = 1.35 ft

Critical Vel. = 6.59 fps.

Note: Crest is essentially paved.

V Control of Pond Discharge

The discharge relations for the Washington St. control were calculated and compared with those for Salem St. At Test Flood pond levels Uptack Rd. should be hydraulically significant.

Pond Elev.	Discharge Rate (cfs)			
	Washington Street		Salem Street	
	With Stoplogs	Without Stoplogs	With Stoplogs	Without Stoplogs
82	2340	2550	2430	2510
81	1210	1420	1250	1340
80	400	600	410	510
79	150	340	220	320
78	120	310	190	310

Control (lowest disch. for given pond elev.) is at Washington St. with all stoplogs in, or just those at Washington St.

Control is at Salem St. with stoplogs removed at Washington St or all stoplogs out.

Ⓟ Failure of Dam

Peak Failure Flow:

Pond Elevation - 79.4 (effective L.P. on crest)

Toe Elevation - 63.5

$Y_0 = 15.9$

Dam Length Subject to Breaching = 85ft

$W_0 = 40\% (85) = 34\text{ft}$

$Q_P = 1.68 W_0 (Y_0)^{1.5} = 1.68 (34) (15.9)^{1.5} \approx 3600 \text{ cfs}$

Ongoing Disch. = 230 cfs, Say Total 3800 cfs

Storage Volume Released:

Storage Above Spillway

Storage Below Spillway

S = Total Storage =

$\left\{ \begin{array}{l} 16(5.7) = 91 \\ 181(0.4) = 72 \end{array} \right\} = 163 \text{ ac-ft}$

$16(3.4) = 55 \text{ ac-ft}$

$\frac{55}{218} \text{ ac-ft, use 220}$

Channel Hydraulics:

$S = \frac{63.5 - 5^4}{1000} = .0095$; $n = 0.10$, $A = 100y + 5y^2$

$P \approx 100 + 10y$; $V = \frac{1.49}{n} R^{2/3} S^{1/2} = 1.452 R^{2/3}$

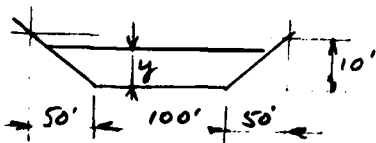

y	A	$R^{2/3}$	V	Q
5	625	2.59	3.76	2350
10	1500	3.83	5.56	8350
2	220	1.50	2.18	400
7	945	3.14	4.56	4310

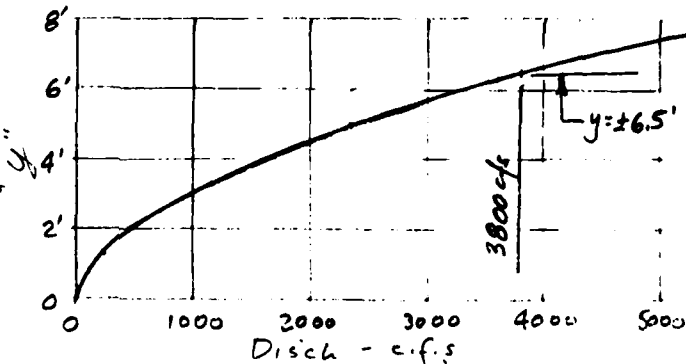

Dam failure increases flow in channel from $\pm 1\text{ft}$ to $\pm 6.5\text{ft}$ depth.

Time to Drain:

$\frac{43500 (220)}{3600 (1/2) (3600)} = 1.5 \text{ Hours.}$

APPENDIX E
INFORMATION AS CONTAINED IN THE
NATIONAL INVENTORY OF DAMS

JOHNSON CREEK DAM AT SALEM STREET



INVENTORY OF DAMS IN THE UNITED STATES

STATE	DIVISION	COUNTY	CONGR. DIST.	NAME	LATITUDE (NORTH)	LONGITUDE (WEST)	REPORT DATE
MA	186	MA 009	06	JOHNSON CREEK DAM AT SALEM STREET	4244.3	7102.6	15AUG79

POPULAR NAME	NAME OF IMPOUNDMENT
	LOWER POND

REGION/BASIN	RIVER OR STREAM	NEAREST DOWNSTREAM CITY-TOWN-VILLAGE	DIST FROM DAM (MI.)	POPULATION
01 06	JOHNSON CREEK	GROVELAND	0	5250

TYPE OF DAM	YEAR COMPLETED	PURPOSES	STRAIGHTENED CHANNEL	HYDRAULIC MEANS	IMPOUNDING CAPACITIES (ACRE-FT.)
	1900	R	16	14	220
REPG					55

DIST OWN FED R PRV/FED SCS A VER/DATE
 NED . N I N N ; N

REMARKS
22-ESTIMATED

D/S HAS LENGTH	SPILLWAY TYPE	MAXIMUM DISCHARGE (FT.)	VOLUME OF DAM (CV)	POWER CAPACITY (KW)	NAVIGATION LOCKS
2	100 U	230	4000		

OWNER	ENGINEERING BY	CONSTRUCTION BY
TOWN OF GROVELAND	UNKNOWN	UNKNOWN

DESIGN	CONSTRUCTION	OPERATION	MAINTENANCE
NONE	NONE	NONE	NONE

INSPECTION BY	INSPECTION DATE	AUTHORITY FOR INSPECTION
METCALF AND EDDY INC	16 APR 79	PL 92-367

REMARKS

END

FILMED

11-84

DTIC